

HAWORTH®

Fixed Height Tables

North America Price List / Specification Guide – February 2020

Includes Cultivate™, Executive Wood, Hoop™, Immerse®, Jive®, Masters Series®, Pip™, Planes®, PopUp™, PREMISE® & Reside®



Electronic Update Page – Collaborative Tables Price List

- The table below lists all of the updates and addendums added to this price list since the original version was created.
- All **Update** pages will replace the existing pages within the document.
- All **New** pages will be placed at the back of the document.

Link	Date	Page	Description
Click Here	February 2020	531, 532, 551, 552	Update – Correction to Cutout Location on Flip-Top Tables.
Click Here	February 2020	551, 552	Update – Correction to Base and Wire Management codes.
Click Here	February 2020	477	Update – Edge option location exception added for C-Leg Tables added.



This Haworth North American price book contains US list prices.

Canadian customers can convert the US list price into their Canadian equivalent by going to www.Haworth.com/Canada to find the current Canadian multipliers. These multiplier factors allow you to convert the US list price into a Canadian list price.

Price Book Overview

The following overview explains how information is organized within this price book.

- 1 Front Cover**
 - Includes the price book title and pricing effectivity date.
- 2 Canadian Conversion / Update Page**
 - Pricing conversion information for converting US pricing into the equivalent Canadian pricing is located on the footer of this page.
 - All Price Book updates will be listed on this page including the date, page number and description of the update.
- 3 Price List Table of Contents**
 - Price List table of contents with page numbers.
- 4 Statement of Line**
 - Provides a pictorial outline of the entire product offering.
- 5 Price List**

Each price list page contains the following:

 - Product Illustration
 - Catalog Number
 - To Order Specify – sequencing for ordering product options and finishes
 - List Prices
 - Product Specification Dimensions
 - Features
 - Specification Tips
 - Class, Discount Group Number (used for discounting) and GSA information
- 6 Finishes, Fabrics and COM**
 - Lists information for material finishes and availability.
 - Provides COM information and requirements (if applicable).
- 7 North American Terms of Sale**
 - Haworth terms for ordering, pricing, shipping and delivery, general terms, and services.
- 8 Index**
 - Products are listed alphabetically by alpha-numeric catalog numbers with price list page number.
- 9 Product Non-Obsolescence and Warranty Policy**
 - Provides information about the Haworth policy for non-obsolence and warranty.

Additional Information and Resources

Prices are subject to change without notice or approval. Haworth dealers should always submit proposals through Lynx before presenting to customers. See North American Terms of Sale for more information.

Online Resources

haworth.com

- Haworth's corporate website provides access to price books and a variety of other resources and publications.

surfaces.haworth.com

- Website provides access to the most current fabrics and finishes offered across Haworth's various product lines.

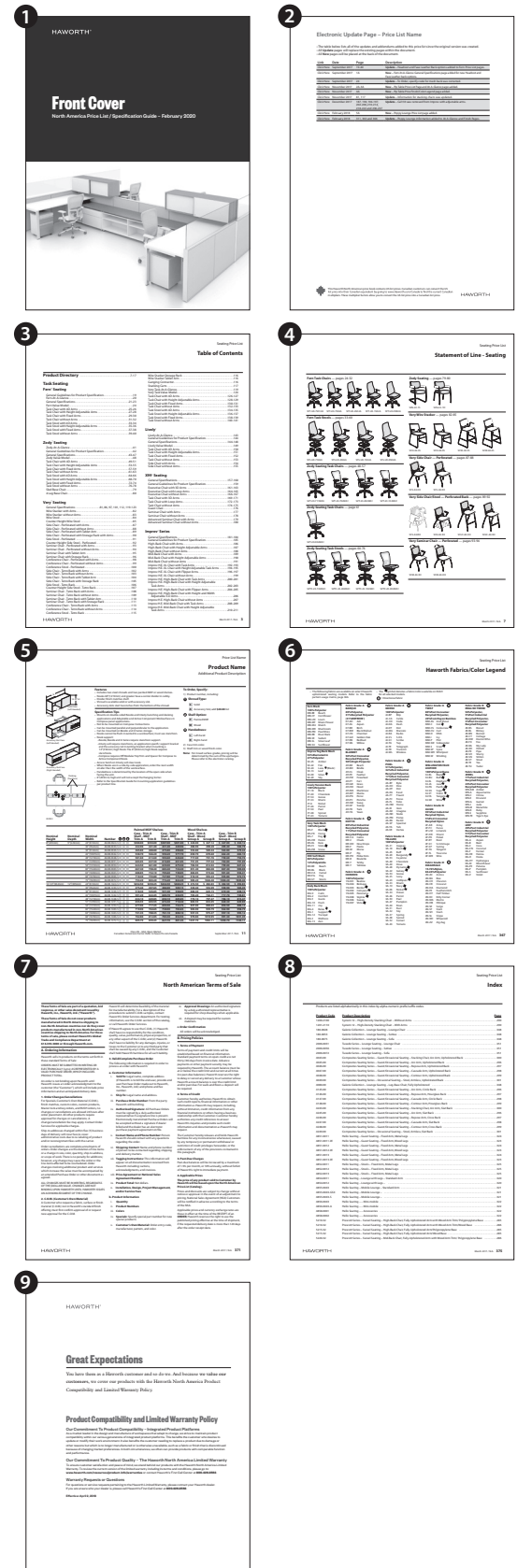

Table of Contents

Statement of Line	7-18	Rectangle/Round – Wood Legs	92
Compose Tables — Laminate		Racetrack/Round – Wood Legs	93
Round — Disc Base	21	Rectangle/Ledge – Wood Legs	94
Round — Post Base	21	Immerse — Shift Table	
Compose Tables — Wood		Rectangle/Rectangle – Painted Legs	95
Round — Disc Base	22	Rectangle/Round – Painted Legs	96
Round — Post Base	22	Racetrack/Round – Painted Legs	97
Cultivate		Rectangle/Rectangle – Wood Legs	98
General Specifications	25-27	Rectangle/Round – Wood Legs	99
Top – No Storage	28	Racetrack/Round – Wood Legs	100
Top - For use with Storage	29	Immerse — Single Table	
Frame	30	Round – Painted Legs	101
Bag Hook	31	Square – Painted Legs	102
Mounting Clip for Flip Top Unit	32	Rectangle – Painted Legs	103
Mounting Bracket for Enhanced Power Modules	32	Racetrack – Painted Legs	104
workware Interface Module Mounting Bracket for		Round – Wood Legs	105
2”(51mm) tops	32	Square – Wood Legs	106
Wire Management Basket	33	Rectangle – Wood Legs	107
Basket Cover	33	Racetrack – Wood Legs	108
Vertical Wire Channel - Leg Attached	33	Immerse — Stack Table	
Executive Conference Buffet		Rectangle – Painted Legs	109
Conference Buffet — Wood	37	Immerse — Planter	
Center Drawer	37	Oblong	110
Executive Wood Tables		Round	111
Specifications	38-39	Improv Series Occasional Tables	
Catalog Logic	40-42	Round Table	115
Statement of Line	43-45	Jive Table — Post Extruded Base	
Base Placement	46	Catalog Logic	119
Round/Square	47	Round – Laminate or Wood	120-121
Base Kits — Round/Square Wood Tables	48	Square – Laminate or Wood	122-123
Rectangular	49-51	Pebble – Laminate or Wood	125-127
Base Kits — Rectangular Wood Tables	52	Rectangle – Laminate or Wood	129-131
Racetrack Tables	53-55	Racetrack – Laminate or Wood	132-133
Base Kits — Racetrack Wood Tables	56	Trapezoid – Laminate or Wood	134
Boat	57-59	Crescent – Laminate or Wood	135
Base Kits — Boat Wood Tables	60	Half Racetrack – Laminate or Wood	136
Wedge	61-63	Pebble Half – Laminate or Wood	137
Base Kits — Wedge Wood Tables	64	Jive Table — Post Round Base	
Executive Wood Tables – A5		Round – Laminate or Wood	138-139
Specifications	65-67	Square – Laminate or Wood	140-141
Rectangular Table Top	68	Pebble – Laminate or Wood	143-145
Boat Table Top	69	Rectangle – Laminate or Wood	147-149
Wedge Table Top	70	Racetrack – Laminate or Wood	150-151
Base Kit	71	Trapezoid – Laminate or Wood	152
Glass Centerpiece	72	Crescent – Laminate or Wood	153
Electric Lift Interface Module	73	Half Racetrack – Laminate or Wood	154
Telecom Plates for Interface	73	Pebble Half – Laminate or Wood	155
Executive Accessories		Jive Table — X-Base	
Presentation Board	74	Round – Laminate or Wood	156-157
Hoop		Square – Laminate or Wood	158-159
Hoop Table	77	Pebble – Laminate or Wood	160-161
Immerse — Ledge Table		Rectangle – Laminate or Wood	162-163
Rectangle – Painted Legs	81	Jive Table — Bridge Base	
Rectangle – Wood Legs	82	Round – Laminate or Wood	164
Immerse — Overlap Table		Square – Laminate or Wood	165
Rectangle/Rectangle – Painted Legs	84-85	Pebble – Laminate or Wood	166-169
Rectangle/Round – Painted Legs	86	Rectangle – Laminate or Wood	171-173
Racetrack/Round – Painted Legs	87	Racetrack – Laminate or Wood	175-177
Rectangle/Ledge – Painted Legs	88	Half Racetrack – Laminate or Wood	178-179
Rectangle/Rectangle – Wood Legs	90-91	Pebble Half – Laminate or Wood	180-181
		Half Hexagon – Laminate or Wood	182

Table of Contents

Jive Table — C-Leg

Rectangle – Laminate or Wood — Extruded	183-185
Rectangle – Laminate or Wood — Round	187-189
Rectangle (Round or Extruded) – Laminate or Wood — Flip Base	190-191

Jive Table — Disc Base

Round – Laminate or Wood	192
Square – Laminate or Wood	193
Pebble – Laminate or Wood	194
Rectangle – Laminate or Wood	195

Jive Table — Dual Disc Base

Pebble – Laminate or Wood	196
Rectangle – Laminate or Wood	197
Racetrack – Laminate or Wood	198

Jive Table — T-Leg — Extruded

Rectangle – Laminate or Wood	199-201
Pebble – Laminate or Wood	202
Racetrack – Laminate or Wood	203
Trapezoid – Laminate or Wood	204

Jive Table — T-Leg — Round

Rectangle – Laminate or Wood	205-207
Pebble – Laminate or Wood	208
Racetrack – Laminate or Wood	209
Trapezoid – Laminate or Wood	210
Rectangle (Round or Extruded) – Laminate or Wood — Flip Base	211-212

Jive Table — Swivel Base

Square – Laminate or Wood	213
Rectangle – Laminate or Wood	214
Trapezoid – Laminate or Wood	215
Crescent – Laminate or Wood	216
Corner, Transitional Extended – Laminate or Wood	217
Corner, Extended – Laminate or Wood	218

Master Series Table — (Round or Square)

Table — Round	221
Square Tables	221

Pip At-A-Glance

General Specifications	225
------------------------------	-----

Pip

Personal Laptop Table	226
-----------------------------	-----

Planes Collaborative Tables

Y-Leg Flip Top or Non-Flip Top Table — Rectangular — Laminate	229
Y-Leg Flip Top or Non-Flip Top Table — Pebble — Laminate	230
Y-Leg Flip Top or Non-Flip Top Table — Hexagon — Laminate	231
Y-Leg Flip Top or Non-Flip Top Table — Half Round — Laminate	232
Y-Leg Flip Top or Non-Flip Top Table — Polygon — Laminate	233
Y-Leg Flip Top or Non-Flip Top Table — Rectangular — Wood	234
Y-Leg Flip Top or Non-Flip Top Table — Pebble — Wood	235
Y-Leg Flip Top or Non-Flip Top Table — Hexagon — Wood	236
Y-Leg Flip Top or Non-Flip Top Table — Half Round — Wood	237
Y-Leg Flip Top or Non-Flip Top Table — Polygon — Wood	238

Planes Collaborative Tables — Accessories

Vertical Wire Management	239
Y-Leg Bumper	239
Ganging Mechanism	239
Ganging Clip	239
Casters	240
Glides	240

Planes Tables — X Base

Laminate or Wood	242-243
------------------------	---------

Planes Tables — Disc Base

Laminate or Wood	244-245
------------------------	---------

Planes Tables — Dual X Base

Laminate or Wood – Rectangle	246-247
Laminate or Wood – Hexagon	248-249
Laminate or Wood – Pebble	250-251

Planes Tables — Dual Disc Base

Laminate or Wood – Rectangle	252-253
Laminate or Wood – Hexagon	254-255
Laminate or Wood – Pebble	256-257

Planes Training Tables

Terminology	258
Product Catalog Logic	259
Flip Top or Non-Flip Top Table — Rectangular — Laminate ..	260-261
Flip Top or Non-Flip Top Table — Crescent — Laminate	262
Flip Top or Non-Flip Top Table — Trapezoid — Laminate	263
Flip Top or Non-Flip Top Table — Polygon — Laminate	264
Pie Connector — Laminate	265
Flip Top or Non-Flip Top Table — Rectangular — Wood	266-267
Flip Top or Non-Flip Top Table — Crescent — Wood	268
Flip Top or Non-Flip Top Table — Trapezoid — Wood	269
Flip Top or Non-Flip Top Table — Polygon — Wood	270
Pie Connector — Wood	271
Modesty Panels	272-273

Planes Training Tables 2-Circuit

Power Feeds — Single Circuit Corded Base Feed — for use with 2-Circuit, 20 Amp	274
Power Feeds — Hardwire Modular Base Feed — 2-Circuit	274
Power Feeds — Wall Feed — 2-Circuit	274
Modular Power Pass-Through — Tables Pass-Through Connector — 2-Circuit	275
Modular Power Kits — 2-Circuit	276
Modular Power Components — Receptacles — 15 Amp 2-Circuit	277
Modular Power Components — Receptacle Block Connector ..	277
Modular Power Components — Four-Port Splitter	277
Modular Power Components — Mounting Bracket — Receptacle	277

Planes Training Tables Accessories

Starter Box	278
Table Pass-Through Connector	278
Starter Box Bracket	278
Wire Manager Clips	278
Flip Top Unit Accessories	280-281
Ganging Mechanism	282
Casters	282
Glides	282
Wire Manager Clips	283
Vertical Wire Manager	283
Grommet	283

Planes Carts

Cart – Small Media – Laminate or Wood	284
Cart – Medium Media – Laminate or Wood	285
Cart – Catering – Laminate	286
Cart – Podium – Laminate or Wood	287

Planes Credenza Bases

Credenza Base – 19”(483mm) High – Laminate or Wood	288
Credenza Base – 29”(737mm) High with Slider Unit – Laminate or Wood	289

Table of Contents

Credenza Base – 35”(889mm) High with Slider Unit – Laminate or Wood	290
Credenza Base – 29”(737mm) High – Laminate or Wood	291
Credenza Base – 39”(991mm) High with Slider Unit – Laminate or Wood	292
Credenza Base – 45”(1143mm) High with Slider Unit – Laminate or Wood	293

Planes Credenza Tops

Credenza Top – Laminate or Wood	294
Grommet	294

Planes Conference Tables

Column Frame (for use with Conference Table Top and End Supported Top)	295
Column Base Plate – Square and Round (for use with Conference Table Top and End Supported Top)	296
Cladding – Flat and Round (for use with Conference Table Top and End Supported Top)	297
J-Channel	298
J-Channel Tray	298
Round, Square, Rectangular – Interior Leg – Laminate	300-301
Half Round – Interior Leg – Laminate	302
Polygon – Interior Leg – Laminate	303
Round, Square, Rectangular – Interior Leg – Wood	304-305
Half Round – Interior Leg – Wood	306
Polygon – Interior Leg – Wood	307
Rectangular – One-Piece Top – Interior Leg – Laminate	308-309
Pebble – One-Piece Top – Interior Leg – Laminate	310-311
Hexagon – One-Piece Top – Interior Leg – Laminate	312-313
Rectangular – One-Piece Top – Interior Leg – Wood	314-315
Pebble – One-Piece Top – Interior Leg – Wood	316-317
Hexagon – One-Piece Top – Interior Leg – Wood	318-319
Rectangular – Two-Piece Tops – Interior Leg – Laminate	320-321
Pebble – Two-Piece Tops – Interior Leg – Laminate	322-323
Hexagon – Two-Piece Tops – Interior Leg – Laminate	324-325
Rectangular – Two-Piece Tops – Interior Leg – Wood	326-327
Pebble – Two-Piece Tops – Interior Leg – Wood	328-329
Hexagon – Two-Piece Tops – Interior Leg – Wood	330-331
Rectangular – Three-Piece Tops – Interior Leg – Laminate	332-333
Pebble – Three-Piece Tops – Interior Leg – Laminate	334-335
Hexagon – Three-Piece Tops – Interior Leg – Laminate	336-337
Rectangular – Three-Piece Tops – Interior Leg – Wood	338-339
Pebble – Three-Piece Tops – Interior Leg – Wood	340-341
Hexagon – Three-Piece Tops – Interior Leg – Wood	342-343
Square and Rectangular – 2”(51mm) Edge – Perimeter Leg – Laminate	344
Rectangular – 2”(51mm) Edge – One-Piece Top – Perimeter Leg – Laminate	345
Rectangular – 2”(51mm) Edge – Two-Piece Tops – Perimeter Leg – Laminate	346-347
Rectangular – 2”(51mm) Edge – Three-Piece Tops – Perimeter Leg – Laminate	348-349
Square and Rectangular – 2”(51mm) Edge – Perimeter Leg – Wood	350
Rectangular – 2”(51mm) Edge – One-Piece Top – Perimeter Leg – Wood	351
Rectangular – 2”(51mm) Edge – Two-Piece Tops – Perimeter Leg – Wood	352-353
Rectangular – 2”(51mm) Edge – Three-Piece Tops – Perimeter Leg – Wood	354-355

Planes Conference Table Top

Catalog Logic	356
Specifications	357-358
Round, Square and Pebble (for use with Column Base) – Laminate or Wood	359
Rectangle (for use with Column Base) – Laminate or Wood ..	361-363
Pebble (for use with Column Base) – Laminate or Wood ..	365-367
Hexagon (for use with Column Base) – Laminate or Wood ..	369-371

Planes End Supported Top — workware Tables

Catalog Logic	373
Specifications	374-375
D-Shape Convergent (for use with Column Base) – Laminate or Wood	376-377
Rectangular Conference End (for use with Column Base) – Laminate or Wood	378-379
Key Conference (for use with Column Base) – Laminate or Wood	380-381
Wall Mount Bracket(s)	382
Side/Corner Bracket	382
Side Bracket for use with Knife Edge	382

Planes — Accessories

Cable Base	383
Cable Column	383
HDMI or VGA Cable	384

Planes — Electrical Accessories

Cable Reel	385
Cable Reel Bracket	385
Cable Management Processor Bracket	386
Cable Base Cable Retractor	386

PopUp Table

Catalog Logic	389
Rectangle – Laminate or Wood	390
Oval (Rectangular Radius Corner) – Laminate or Wood	391
Racetrack – Laminate or Wood	392
Accent Plate	393
Vertical Wire Channel – Leg Attached	394

PREMISE

Tri Tables — Transactional – Symmetric with Glides or Casters ..	397
Square — Laminate or Wood Top	398
Round — Laminate or Wood Top	398
Oval — Laminate or Wood Top	399
Rectangular — Laminate or Wood Top	399
Teardrop — Laminate Top	400

Reside Tables — Laminate/Wood

Square	403
Round and Pebble	404
Hex	405
Rectangular	406

Finish/Color Legends

North American Terms of Sale

Index

Lifetime Product Warranty

Statement of Line

Compose Tables — Pages 21-22



TZRN-L
Round — Disc Base -
Laminate

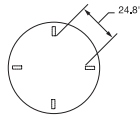

TZRN-LG
Round — Post Base -
Laminate



TZRN-W
Round — Disc Base -
Wood

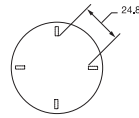

TZRN-WG
Round — Post Base -
Wood

Cultivate Tops — Pages 28-29



TYRA-LJSN
TYRA-WKSN
TYRA-LJMN
TYRA-WKMN
No Storage

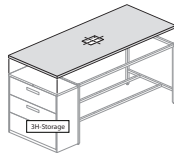

TYRA-LJSN
TYRA-WKSN
TYRA-LJMN
TYRA-WKMN
With Storage - 3 High

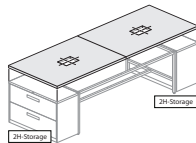

TYRA-LJSN
TYRA-WKSN
TYRA-LJMN
TYRA-WKMN
With Storage - 2 High

Cultivate Frames — Page 30

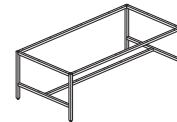

TYBA-NNNNNG4A
Seated Height

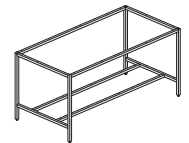

TYBA-NNNNNG7A
Standing Height

Cultivate Bag Hook — Page 31

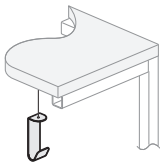

KUWH-0202

Cultivate Power Module Clips and Brackets — Page 32

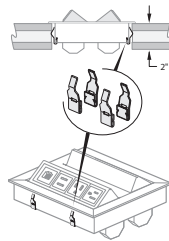

EUMC-0201
Mounting Clip
for Flip Top Unit

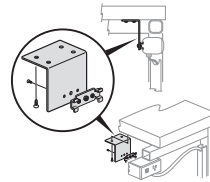

EUDB-0000
Mounting Bracket
for Enhanced Power
Modules

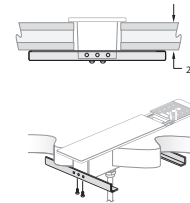

EWWM-0601
workware Interface
Module Mounting Bracket
for 2" (51mm) tops

Cultivate Wire Management — Page 33

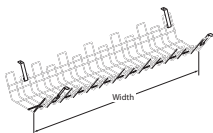

TAWB
Wire Management
Basket

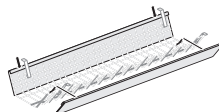

TABC
Basket Cover

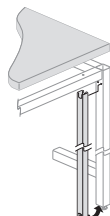

TYVW
Vertical Wire Channel -
Leg Attached

Executive Conference Buffet — Page 37

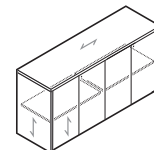

TECB
Conference Buffet - Wood

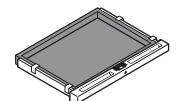

UXCD-N
Center Drawer

Statement of Line

Executive Wood Tables — Pages 47-64

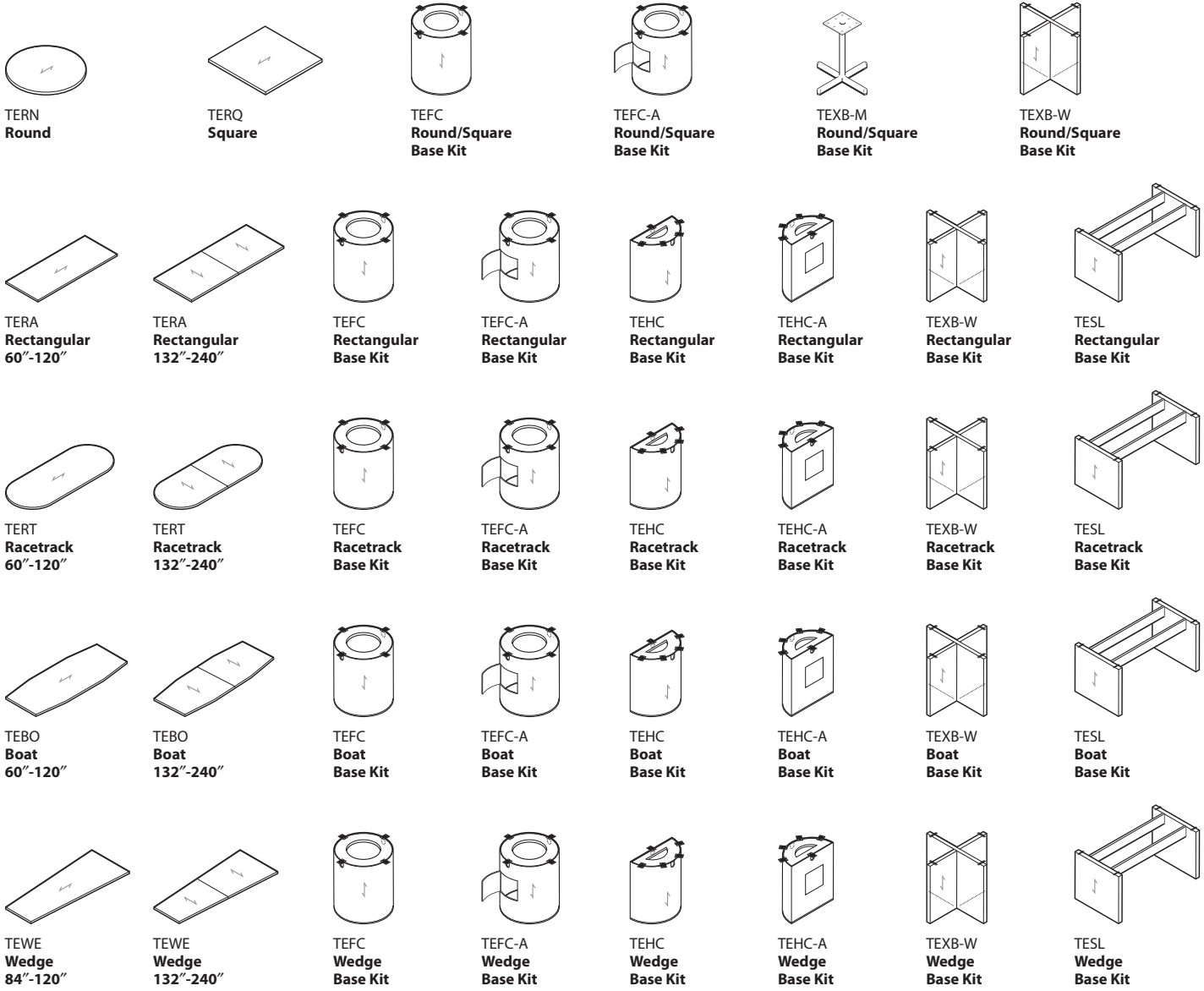

Executive Wood Tables – A5 — Pages 68-73

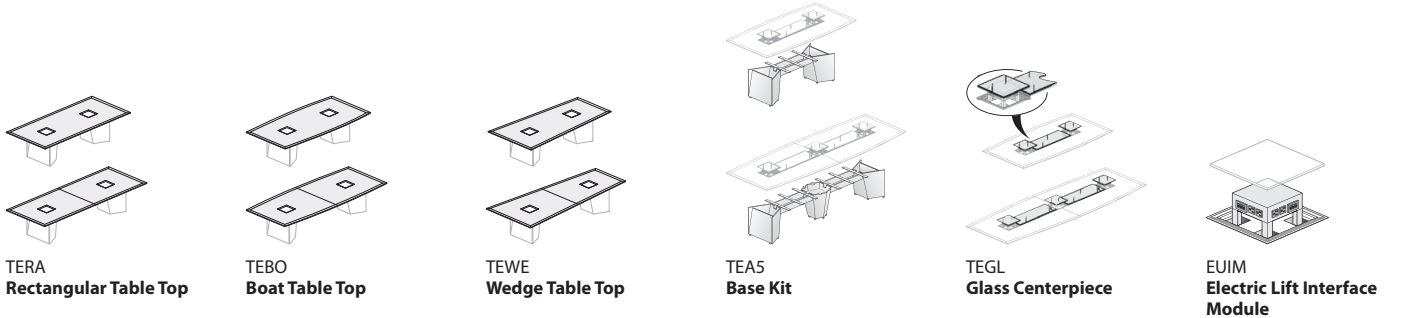

Statement of Line

Executive Accessories — Page 74

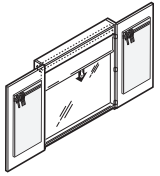

TEPB
Presentation Board

Hoop — Page 77

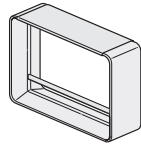

T7MB-1860-7
Hoop Table

Immerse — Pages 81-109



THLD-P
Ledge Table
Rectangle
Painted Legs



THLD-W
Ledge Table
Rectangle
Wood Legs



THRR
Overlap Table
Rectangle/Rectangle
Painted Legs



THRD
Overlap Table
Rectangle/Round
Painted Legs



THTD
Overlap Table
Racetrack/Round
Painted Legs



THRL
Overlap Table
Rectangle/Ledge
Painted Legs



THRR
Overlap Table
Rectangle/Rectangle
Wood Legs



THRD
Overlap Table
Rectangle/Round
Wood Legs



THTD
Overlap Table
Racetrack/Round
Wood Legs



THRL
Overlap Table
Rectangle/Ledge
Wood Legs



THRR
Shift Table
Rectangle/Rectangle
Painted Legs



THRD
Shift Table
Rectangle/Round
Painted Legs



THTD
Shift Table
Racetrack/Round
Painted Legs



THRR
Shift Table
Rectangle/Rectangle
Wood Legs



THRD
Shift Table
Rectangle/Round
Wood Legs



THTD
Shift Table
Racetrack/Round
Wood Legs



THRN
Single Table
Round
Painted Legs



THRQ
Single Table
Square
Painted Legs



THRA
Single Table
Rectangle
Painted Legs



THRT
Single Table
Racetrack
Painted Legs

Statement of Line

Immerse (continued) — Pages 81-109



THRN
Single Table
Round
Wood Legs



THRQ
Single Table
Square
Wood Legs



THRA
Single Table
Rectangle
Wood Legs



THRT
Single Table
Racetrack
Wood Legs

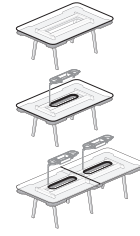

THRA
Stack Table
Rectangle
Painted Legs

Immerse — Planter — Pages 110-111

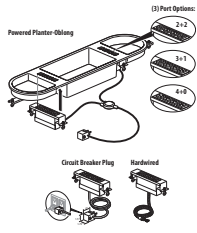
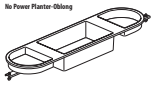

EHPO
Oblong

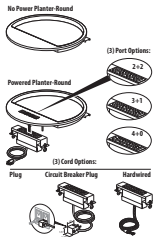

EHPR
Round

Improv Series — Page 115



MTR1-20
Round Table



(top view)

Jive Table — Post Extruded Base — Pages 120-137



TCRN
Round

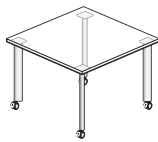

TCRQ
Square



TCRP-4242
Pebble
(Symmetrical)



TCRP-3060
Pebble
(Asymmetrical)

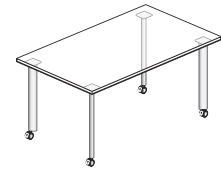

TCRA
Rectangle

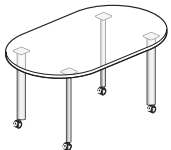

TCRT
Racetrack

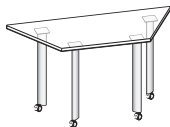

TCTP
Trapezoid

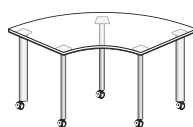

TCBN
Crescent

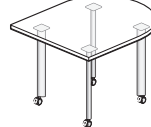

TCHT
Half Racetrack

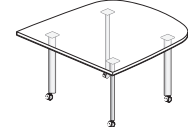

TCHP
Pebble Half

Statement of Line

Jive Table — Post Round Base — Pages 138-155



TCRN-SNV
Round

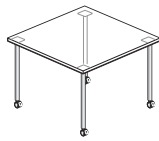

TCRQ-SNV
Square



TCRP-4242-SNV
Pebble
(Symmetrical)



TCRP-3060-SNV
Pebble
(Asymmetrical)

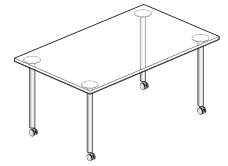

TCRA-SNV
Rectangle



TCRT-SNV
Racetrack



TCTP-SNV
Trapezoid



TCBN-SNV
Crescent



TCHT
Half Racetrack

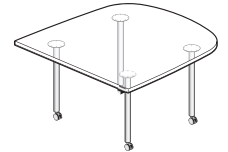

TCHP
Pebble Half

Jive Table — X-Base — Pages 156-163

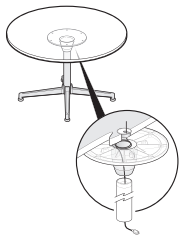

TCRN-SNXF
Round
(Power)



TCRN-SNX
Round
(No Power)

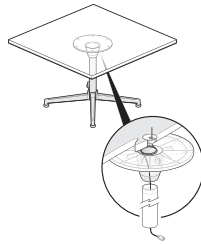

TCRQ-SNXF
Square
(Power)



TCRQ-SNX
Square
(No Power)

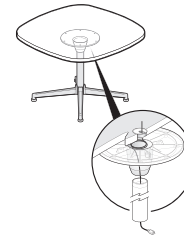

TCRP-SNXF
Pebble
(Power)



TCRP-SNX
Pebble
(No Power)

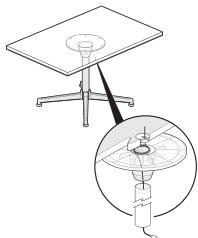

TCRA-SNXF
Rectangular
(Power)



TCRA-SNX
Rectangular
(No Power)

Jive Table — Bridge Base — Pages 164-182



TCRN-SNG
Round



TCRQ-SNG
Square



TCRP-5454-SNG
Pebble
(Symmetrical)



TCRP-3048-SNG
Pebble
(Asymmetrical)



TCRA-SNG
Rectangle



TCRT-SNG
Racetrack

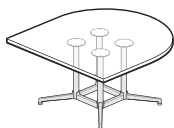

TCHT-SNG
Half Racetrack

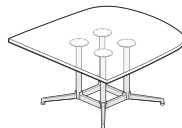

TCHP-SNG
Pebble Half



TCHX-SNG
Half Hexagon

Statement of Line

Jive Table — C-Leg — Extruded — Pages 183-189

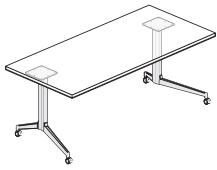

TCRA-SNC
Rectangle

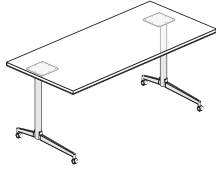

TCRA-SNB
Rectangle

Jive Table — C-Leg — Flip Base — Pages 190-191



TCRA-SNH

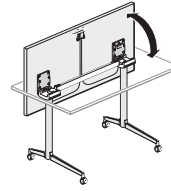

Jive Table — Disc Base — Pages 192-195

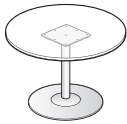

TCRN-SND
Round

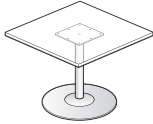

TCRQ-SND
Square



TCRP-2424
Pebble
(Symmetrical)

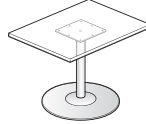

TCRA-SND
Rectangle



TCRP-3060
Pebble
(Asymmetrical)

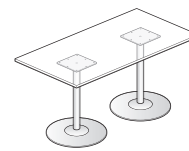

TCRA-SND
Rectangle



TCRT-SND
Racetrack

Jive Table — T-Leg — Extruded — Pages 199-204

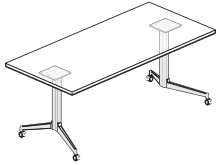

TCRA-SNT
Rectangle



TCRP-SNT
Pebble



TCRT-SNT
Racetrack



TCTP-SNT
Trapezoid

Jive Table — T-Leg — Round — Pages 205-210



TCRA-SNF
Rectangle



TCRP-SNF
Pebble



TCRT-SNE
Racetrack



TCTP-SNF
Trapezoid



TCRA-SNFH4
Rectangle

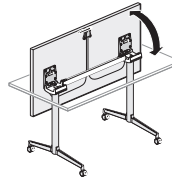

Jive Table — Swivel Base — Pages 213-218

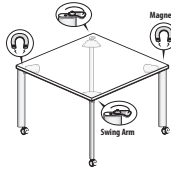

TVRQ-LJSNR
Square

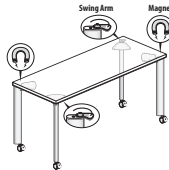

TCRA-LJSNR
Rectangle

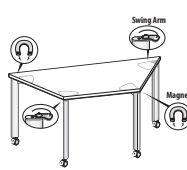

TVTP-LJSNR
Trapezoid

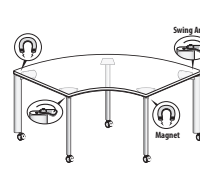

TVBN-LJSNR
Crescent

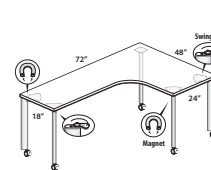

TVCX-LJSNRP
Corner, Transitional
Extended

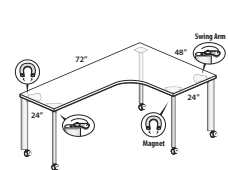

TVCE-LJSNRE
Corner, Extended

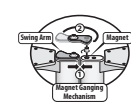
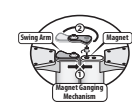
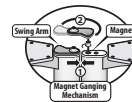
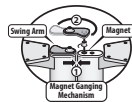
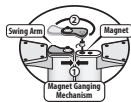
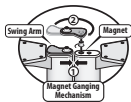

Statement of Line

Master Series — Page 221

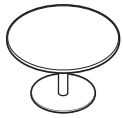

XZAM-1S
Round

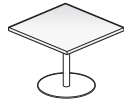

XLAS-3030
XZAS-3030
Square



STP-P26-TH
Personal Laptop Table

Pip — Page 226

Planes Collaborative Tables — Y-Leg Flip-Top/Non-Flip Top — Laminate — Pages 229-233 / Wood — Pages 234-238



TARA
Rectangular



TARP
Pebble



TARX
Hexagon



TAHN
Half Round



TACV
Polygon

Planes Collaborative Tables — Accessories — Pages 239-240



TA01-0212
Vertical Wire Management

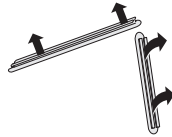

TA01-0213
TA01-0214
Y-Leg Bumper

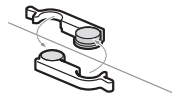

TA01-0222
Ganging Mechanism



TA01-0001
Ganging Clip



TA01-0216
Casters

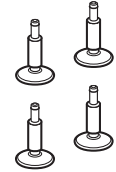

TA01-0215
Glides

Planes Table — Pages 242-257

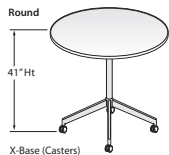

TARN-NXC
Round — X Base

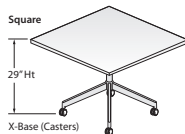

TARQ-NXC
Square — X Base

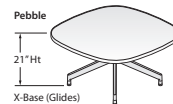

TARP-NXG
Pebble — X Base

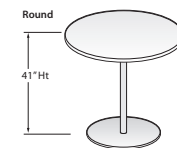

TARN-NDN
Round — Disc Base

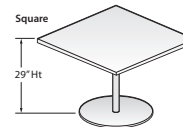

TARQ-NDN
Square — Disc Base

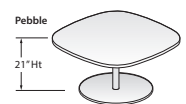

TARP-NDN
Pebble — Disc Base



TARA-XC
Rectangle — Dual X Base



TARX-XC
Hexagon — Dual X Base



TARP-XC
Pebble — Dual X Base

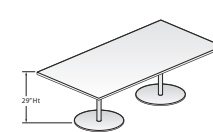

TARA-D
Rectangle — Dual Disc Base

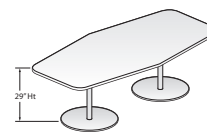

TARX-D
Hexagon — Dual Disc Base



TARP-D
Pebble — Dual Disc Base

Planes Training Tables – Laminate — Pages 260-265 / Wood — Pages 266-271



TARA-L
TARA-W
Rectangular



TABN-L
TABN-W
Crescent



TATP-L
TATP-W
Trapezoid



TACV-L
TACV-W
Polygon

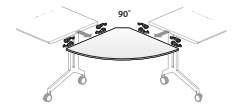

TAPC-L
TAPC-W
Pie Connector

Planes Training Table Modesty Panels — Pages 272-273

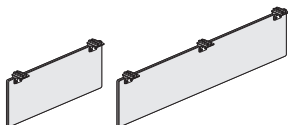



TA0M
Modesty Panels

Statement of Line

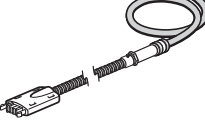
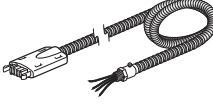
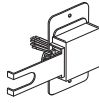
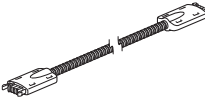
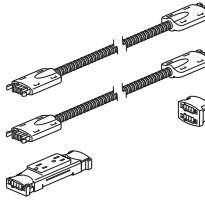
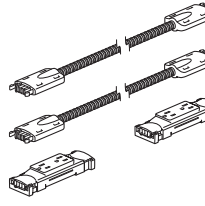
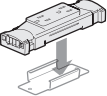
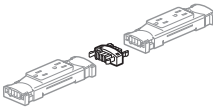
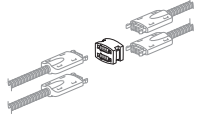
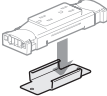

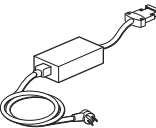

Planes Training Tables 2-Circuit Modular Power Components — Pages 274-277

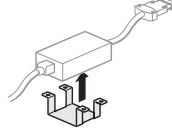
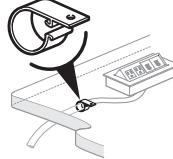
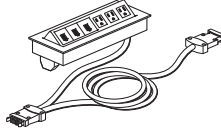
  EAEB-2024-2C Single Circuit Corded Base Feed — for use with 2-Circuit, 20 Amp	 EAEB Hardwire Modular Base Feed — 2-Circuit	 EAWP-0004-21 Wall Feed — 2-Circuit	 EAEJ Tables Pass-Through Connector — 2-Circuit	 EAEM (One receptacle) Modular Power Kits — 2-Circuit	 EAEM (Two receptacles) Modular Power Kits — 2-Circuit
 EAER Receptacles — 15 Amp 2-Circuit	 EAED-0000-22 Receptacle Block Connector	 EAED-0000-24 Four-Port Splitter	 TA01-0224 Mounting Bracket — Receptacle		

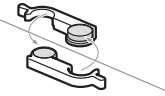
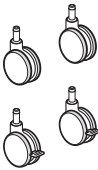

Planes Training Tables Quick Connect Power – Flip Top Unit Accessories — Pages 278-281

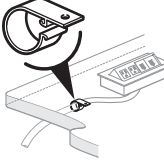
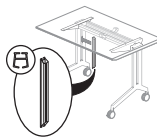
 EAEB Starter Box	 EAEJ-1 Table Pass-Through Connector	 TA01-0227 Starter Box Bracket	 TA01-0225 Wire Management Clip	 EAE1-A331 Quick Connect Power
--	--	--	---	---

Planes Accessories — Pages 282-283

 TA01-0222 Ganging Mechanism	 TA01-0216 Casters	 TA01-0215 Glides	 TA01-0225 Wire Manager Clips	 TA01-0228 Vertical Wire Manager	 WQAG-PS Grommet
--	---	--	--	---	---

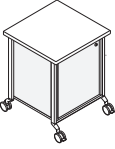
Planes Carts — Pages 284-287

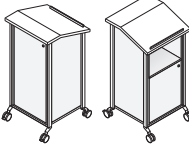
 GAKF-1919 Small Media Laminate or Wood	 GAKE-1919 Medium Media Laminate or Wood	 GAKG-1935 Catering Laminate	 GAKD-1919 Podium Laminate or Wood
---	---	---	---

Statement of Line

Planes Credenza Bases — Pages 288-293

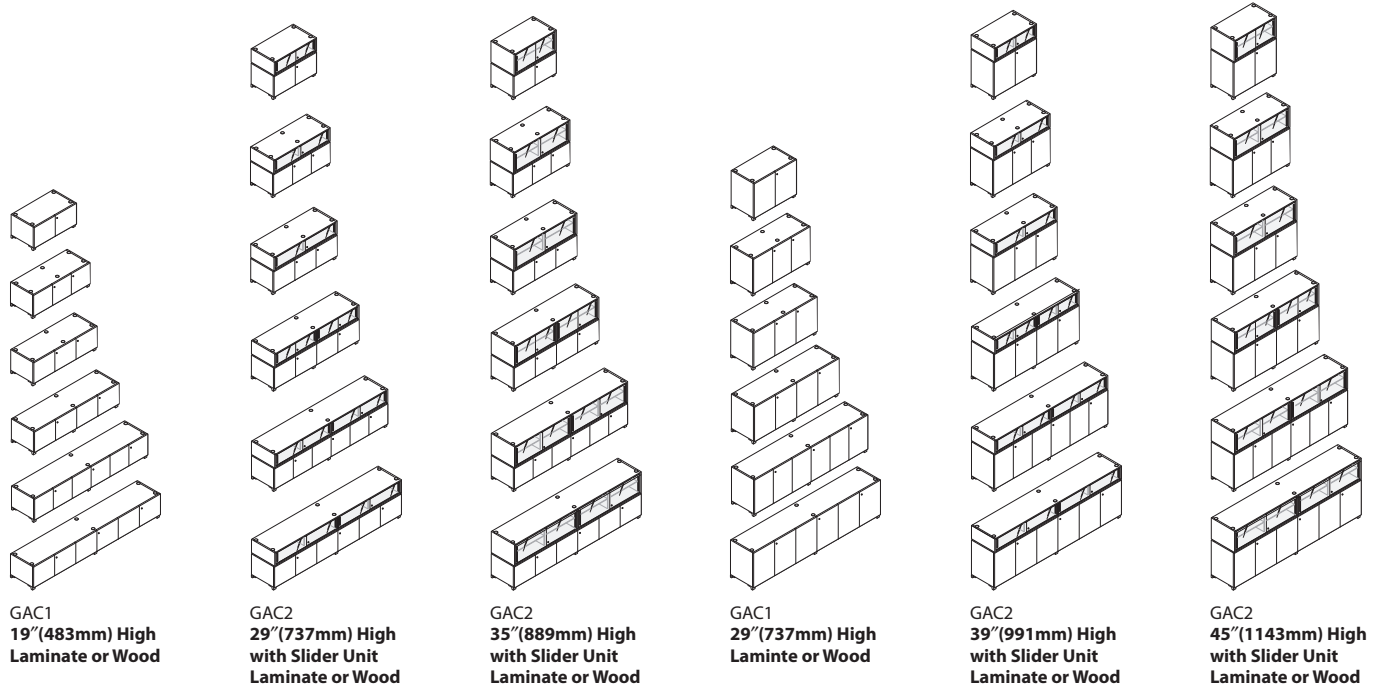

Planes Credenza Tops — Page 294

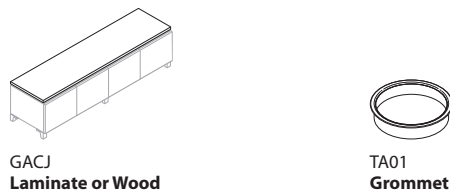

Planes Conference Table – Column Base (for use with Conference Table Top and End Supported Top) — Pages 295-298

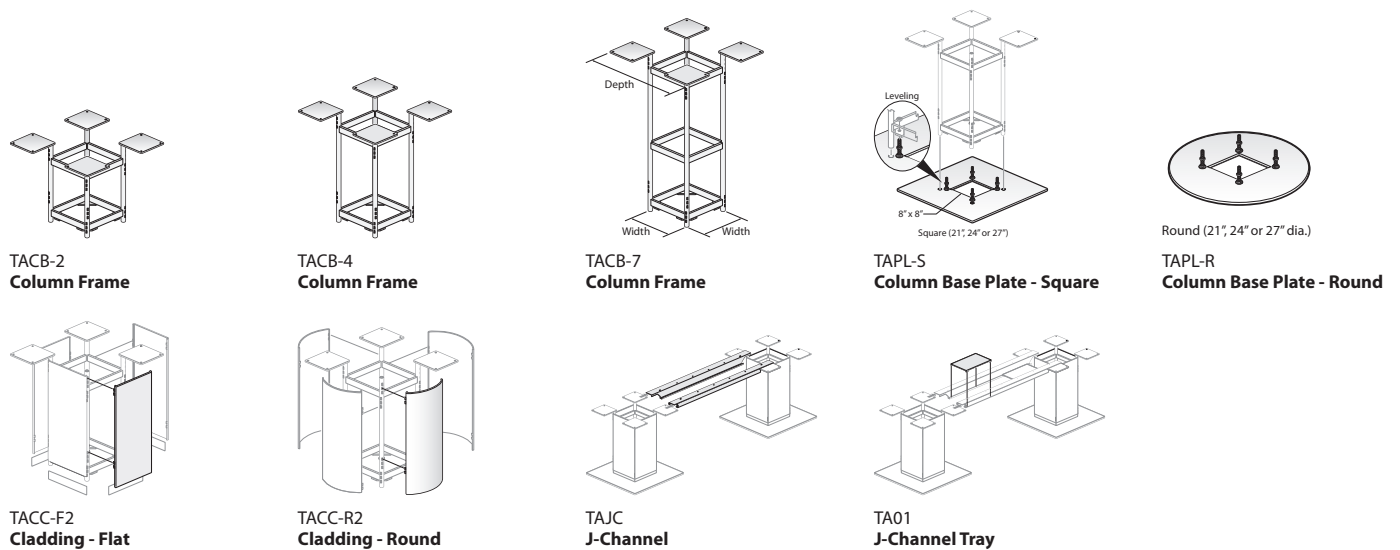

Statement of Line

Planes Conference Tables – Interior Leg — Pages 300-307



TARN
Round
Laminate



TARQ
Square
Laminate

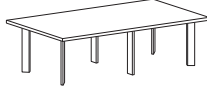

TARA
Rectangular
Laminate

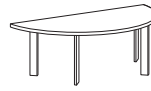

TAHN
Half Round
Laminate

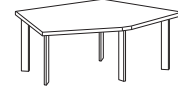

TACV
Polygon
Laminate



TARN
Round
Wood



TARQ
Square
Wood

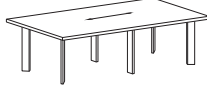

TARA
Rectangular
Wood



TAHN
Half Round
Wood



TACV
Polygon
Wood

Planes Conference Tables – One-Piece Top – Interior Leg — Pages 308-319

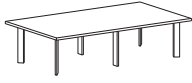

TARA
Rectangular
Laminate



TARP
Pebble
Laminate



TARX
Hexagon
Laminate



TARA
Rectangular
Wood



TARP
Pebble
Wood



TARX
Hexagon
Wood

Planes Conference Tables – Two-Piece Tops – Interior Leg — Pages 320-331



TARA
Rectangular
Laminate



TARP
Pebble
Laminate



TARX
Hexagon
Laminate



TARA
Rectangular
Wood



TARP
Pebble
Wood



TARX
Hexagon
Wood

Planes Conference Tables – Three-Piece Tops – Interior Leg — Pages 332-343



TARA
Rectangular
Laminate



TARP
Pebble
Laminate



TARX
Hexagon
Laminate



TARA
Rectangular
Wood



TARP
Pebble
Wood



TARX
Hexagon
Wood

Planes Conference Tables – Perimeter Leg – Laminate — Pages 344-349



TARQ
Square
2"(51mm) Edge



TARA
Rectangular
2"(51mm) Edge



TARA
One-Piece Top
Rectangular
2"(51mm) Edge



TARA
Two-Piece Tops
Rectangular
2"(51mm) Edge



TARA
Three-Piece Tops
Rectangular
2"(51mm) Edge

Planes Conference Tables – Perimeter Leg – Wood — Pages 350-355



TARQ
Square
2"(51mm) Edge



TARA
Rectangular
2"(51mm) Edge



TARA
One-Piece Top
Rectangular
2"(51mm) Edge



TARA
Two-Piece Tops
Rectangular
2"(51mm) Edge



TARA
Three-Piece Tops
Rectangular
2"(51mm) Edge

Statement of Line

Planes Conference Table Top (for use with Column Base) – Laminate or Wood — Pages 359-371



TARN
Round

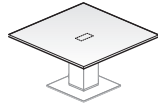

TARQ
Square



TARP
Pebble

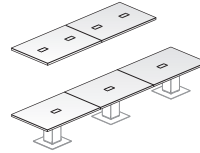

TARA
Rectangle

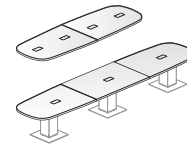

TARP
Pebble

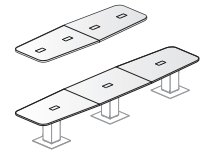

TARX
Hexagon

Planes End Supported Top (for use with Column Base) — Pages 376-382

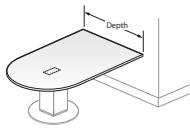

TARD
D-Shape Convergent
Laminate or Wood

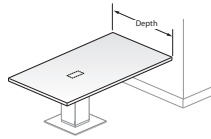

TARU
Rectangular
Conference End
Laminate or Wood

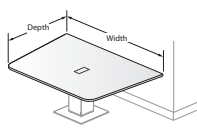

TARY
Key Conference
Laminate or Wood



ZUBW-0000-PN
Wall Mount Bracket(s)

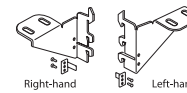

ZZBA-0000-PR
ZZBA-0000-PL
Side/Corner Bracket

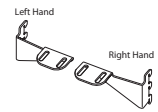

ZZBA-0000-PRF
ZZBA-0000-PLF
Side Bracket for use with
Knife Edge

Planes Accessories — Pages 383-384

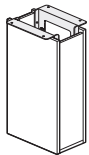

TA01-0814
Cable Base

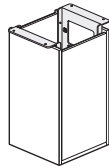

TA01-1414
Cable Base



TA01-0217
Cable Column



EWCX-H
HDMI Cable

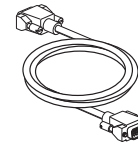

EWCX-5001-V
VGA Cable

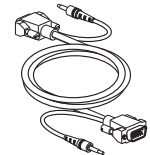

EWCX-V
VGA Cable

Planes Electrical Accessories — Pages 385-386

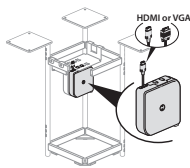

TA01-CR48
Cable Reel

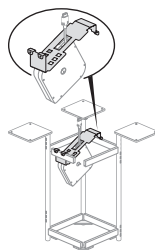

TA01-CRBK
Cable Reel Bracket

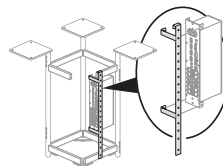

TA01-PB21
Cable Management Processor
Bracket

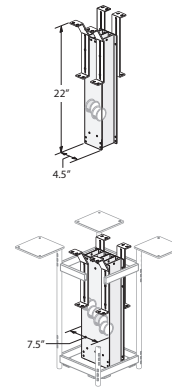

EWCX-BRWM
Cable Base Cable Retractor

Statement of Line

PopUp Table — Pages 390-394



TPRA-SNA
Rectangle
Laminate or Wood



TPRP-SNA
Oval — Rectangle
Radius Corner
Laminate or Wood



TPRT-SNA
Racetrack
Laminate or Wood



TPAP
Accent Plate

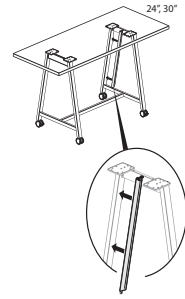

TPVW
Vertical Wire Channel —
Leg Attached

PREMISE Tables — Pages 397-400



NCTY-LFG
NCTY-LVG
Transactional —
Symmetric with
Glides or Casters



NCTY-LFM
NCTY-LVM
Transactional —
Symmetric with
Glides or Casters



NCSL
NCSW
Square
Laminate or Wood



NCCL
NCCW
Round
Laminate or Wood



NCVL
NCVW
Oval
Laminate or Wood

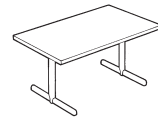

NCRL
NCRW
Rectangular
Laminate or Wood



NCOL
NCOL-C
Teardrop
Laminate

Reside Table Laminate/Wood — Pages 403-406



TKRQ
Square



TKRN
Round



TKRP
Pebble

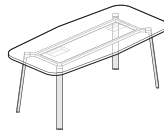

TKRX
Hex

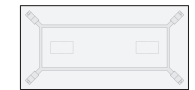
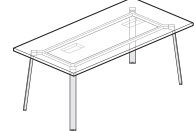

TKRA
Rectangular

Compose

This page intentionally blank

Compose Tables — Laminate

	Diameter	Number ①	Laminate A		Laminate B	
			J	F	J	F
Round — Disc Base	30"(762mm)	TZRN-3030-L ■ SCZ	\$1583.92	\$1939.72	\$1605.56	\$1961.36
	36"(914mm)	TZRN-3636-L ■ SCZ	1940.66	2302.70	1963.84	2325.88
	42"(1067mm)	TZRN-4242-L ■ SCZ	2361.04	2729.32	2386.04	2754.32
	48"(1219mm)	TZRN-4848-L ■ SCZ	2845.06	3219.58	2872.16	3246.68

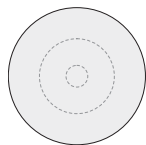

TZRN-L

Features

- Includes top and disc base.
- 30"(762mm) and 36"(914mm) includes 21"(533mm) disc base.
- 42"(1067mm) and 48"(1219mm) includes 27"(686mm) disc base.
- Fixed height base: 29 1/4"(743mm).

To Order, Specify:

- 1) Product number, including:

① Edge Option:

J Edgeband

F Knife

- 2) Laminate surface color.
- 3) Edge trim color.
- 4) Base trim color.

Note: \$19.30 upcharge list for Metallic and accent trim color.

Round — Post Base	48"(1219mm)	TZRN-4848-L ■ SCJG	\$2845.06	\$3219.58	\$2872.16	\$3246.68
	60"(1524mm)	TZRN-6060-L ■ SCJG	4141.86	4528.86	4174.00	4561.00

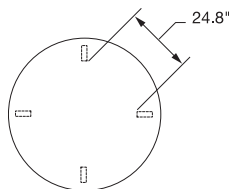

TZRN-LG

Features

- Includes top and four post legs with glides.
- Height adjustable- 26"(660mm)-32"(813mm) in 1/2" increments.

To Order, Specify:

- 1) Product number, including:

① Edge Option:

J Edgeband

F Knife

- 2) Laminate surface color.
- 3) Edge trim color.
- 4) Base trim color.

Note: \$19.30 upcharge list for Metallic and accent trim color.

Compose Tables — Wood

	Diameter	Number ^①	Wood Group A		Wood Group B	
			K	U	K	U
Round — Disc Base	30"(762mm)	TZRN-3030-W SCZ	\$3283.45	\$3644.05	\$3635.49	\$4008.09
	36"(914mm)	TZRN-3636-W SCZ	3322.91	3690.71	3677.28	4059.48
	42"(1067mm)	TZRN-4242-W SCZ	3368.41	3743.41	3725.49	4117.29
	48"(1219mm)	TZRN-4848-W SCZ	3419.95	3802.15	3780.12	4181.52

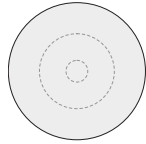

TZRN-W

Features

- Includes top and disc base.
- 30"(762mm) and 36"(914mm) includes 21"(533mm) disc base.
- 42"(1067mm) and 48"(1219mm) includes 27"(686mm) disc base.
- Fixed height base: 29 1/4".

To Order, Specify:

- 1) Product number, including:

① Edge Option:

- K** Edgeband
- U** Knife

- 2) Wood finish color.
- 3) Base trim color.

***Note:** \$19.30 upcharge list for Metallic and accent trim color.

Round — Post Base	48"(1219mm)	TZRN-4848-W SCJG	\$3419.95	\$3802.15	\$3780.12	\$4181.52
--------------------------	-------------	------------------	-----------	-----------	-----------	-----------

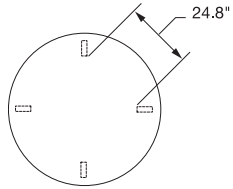

TZRN-WG

Features

- Includes top and four post legs with glides.
- Height adjustable- 26"(660mm)-32"(813mm) in 1/2" increments.

To Order, Specify:

- 1) Product number, including:

① Edge Option:

- K** Edgeband
- U** Knife

- 2) Wood finish color.
- 3) Base trim color.

***Note:** \$19.30 upcharge list for Metallic and accent trim color.

Cultivate

This page intentionally blank

Cultivate General Specifications

Tops

EXAMPLE: Cultivate, Top, 36"X60", Laminate, Edgeband, 1 3/16" Core, No Cutout.

TY **RA** **-** **36** **60** **-** **L** **J** **S** **N**

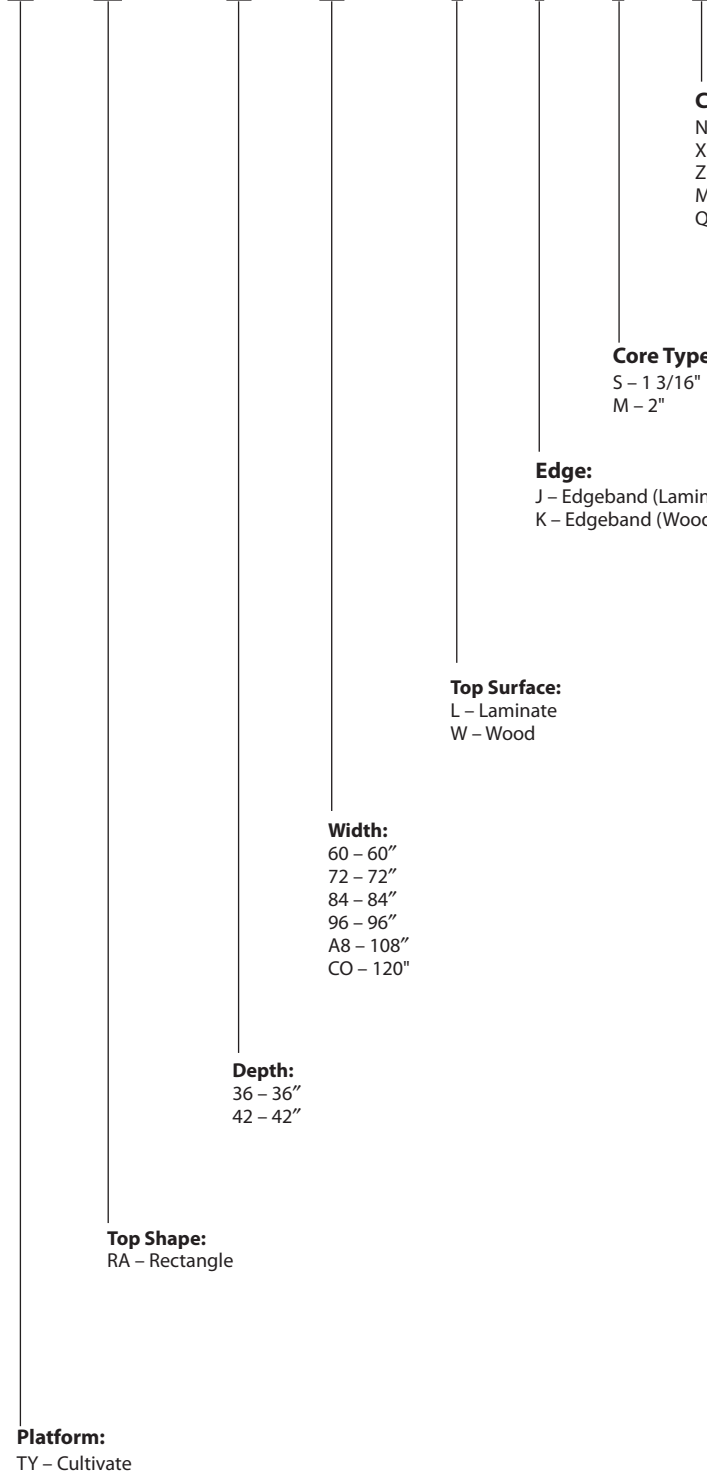

Cutout:

- N - None
- X - Center, Single-Sided 4 outlets
- Z - Center, Single-Sided 6 outlets
- M - Center, Double-Sided 8 outlets
- Q - Center, Double-Sided 12 outlets

Core Type:

- S - 1 3/16"
- M - 2"

Edge:

- J - Edgeband (Laminate)
- K - Edgeband (Wood)

Top Surface:

- L - Laminate
- W - Wood

Width:

- 60 - 60"
- 72 - 72"
- 84 - 84"
- 96 - 96"
- A8 - 108"
- CO - 120"

Depth:

- 36 - 36"
- 42 - 42"

Top Shape:

- RA - Rectangle

Platform:

- TY - Cultivate

Cultivate General Specifications

Tops for use with Storage

EXAMPLE: Cultivate, Top, 36"X79", Laminate, Edgeband, 1 3/16" Core, No Cutout.

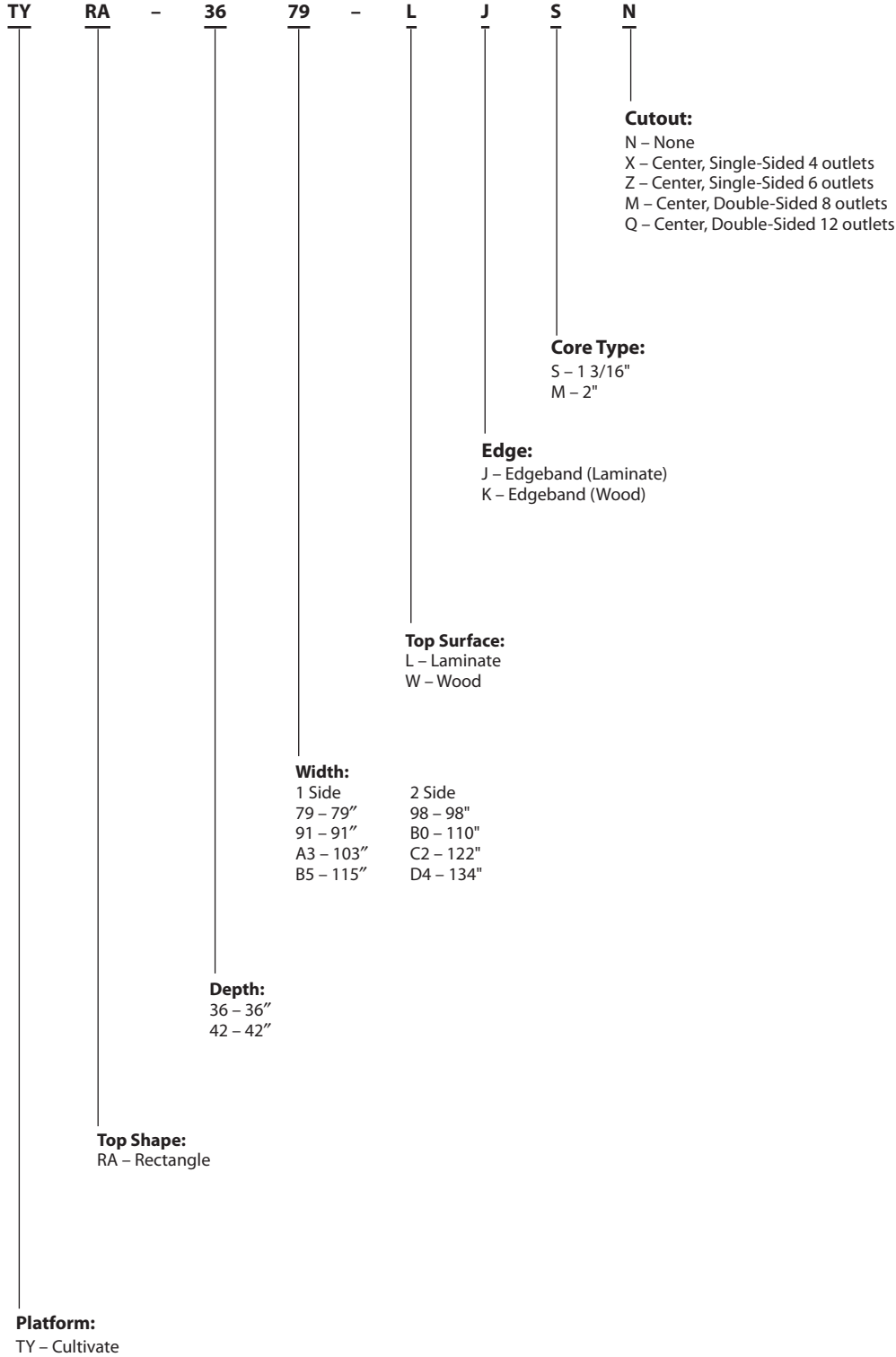

Cultivate General Specifications

Frames

EXAMPLE: Cultivate, Base Only, 36"X60", Glides, 28"H, Painted.

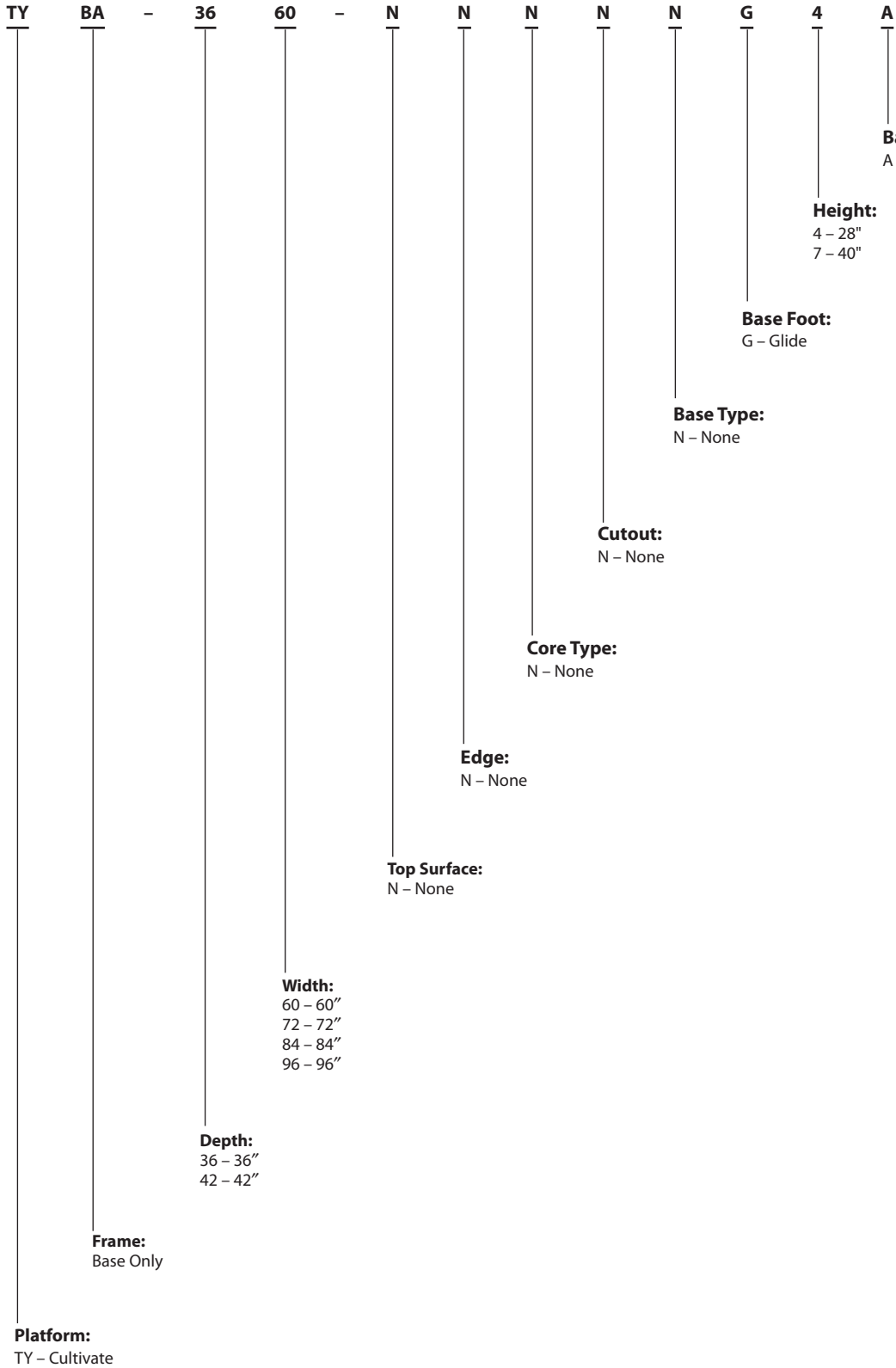

Cultivate Tops

Top – No Storage

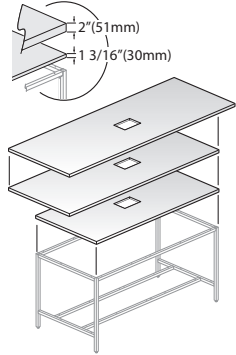

TYRA-LJSN
TYRA-WKSN
TYRA-LJMN
TYRA-WKMN

Features

- Includes pre-drilled 1 3/16" (30mm) or 2" (51mm) thick top.
- Laminate top with 3mm edgeband or wood veneer top with 3mm wood edgeband.

Specification Tips

- Tops are allowed to overhang the frame width and depth.
- 60" (1524mm), 72" (1829mm), 84" (2134mm) and 96" (2438mm) tops are flush to the frame. 108" (2743mm) and 120" (3048mm) tops will overhang the frame by 12" (305mm) on each side.
- Cutouts are optional. If specified they are factory installed.
- Each cutout requires a separately specified Flush Mount or Flip Top Double-Sided Unit power module.
- All other power options require field modification.
- These top sizes are not dimensioned for use with storage.
- Separately specified:
 - Frame
 - Horizontal and Vertical Wire Management
 - Power and Data Components
 - Accessories

To Order, Specify:

1) Product number, including:

1 Surface Option:

- L** Laminate
- W** Wood

2 Edge Option:

- J** Edgeband (Laminate)
- K** Edgeband (Wood)

3 Cutout Option:

- N** No Cutout
- X** Center, Flush Mount Power/4 ports, add \$33.13 list
- Z** Center, Flush Mount Power/6 ports, add \$33.13 list
- M** Center, Flip Top Double-Sided/8 ports, add \$33.13 list
- Q** Center, Flip Top Double-Sided/12 ports, add \$33.13 list

2) Laminate surface color or Wood surface color.
3) Edge trim color (laminate only).

No. of Pieces	Seating Capacity	Depth	Top Width	Pre-drilled for Frame Width	Number	① ② ③			Laminate A	B	Wood Group A	Group B
1 3/16" (30mm) Thick Top												
1		36" (914mm)	60" (1524mm)	60" (1524mm)	TYRA-3660-			S	\$ 333.84	\$ 411.31	\$ 641.81	\$ 715.87
1			72" (1829mm)	72" (1829mm)	TYRA-3672-			S	374.40	455.11	698.45	782.59
1			84" (2134mm)	84" (2134mm)	TYRA-3684-			S	414.96	498.91	755.09	849.31
1			96" (2438mm)	96" (2438mm)	TYRA-3696-			S	455.52	542.71	811.73	916.03
1			108" (2743mm)	84" (2134mm)	TYRA-36A8-			S	496.08	586.51	868.37	982.75
1			120" (3048mm)	96" (2438mm)	TYRA-36C0-			S	536.64	630.31	925.01	1049.47
1		42" (1067mm)	60" (1524mm)	60" (1524mm)	TYRA-4260-			S	\$ 360.88	\$ 440.51	\$ 679.57	\$ 760.35
1			72" (1829mm)	72" (1829mm)	TYRA-4272-			S	414.96	498.91	755.09	849.31
1			84" (2134mm)	84" (2134mm)	TYRA-4284-			S	455.52	542.71	811.73	916.03
1			96" (2438mm)	96" (2438mm)	TYRA-4296-			S	509.60	601.11	887.25	1004.99
1			108" (2743mm)	84" (2134mm)	TYRA-42A8-			S	674.96	769.71	1068.69	1196.51
1			120" (3048mm)	96" (2438mm)	TYRA-42C0-			S	729.04	828.11	1144.21	1285.47
2" (51mm) Thick Top												
1		36" (914mm)	60" (1524mm)	60" (1524mm)	TYRA-3660-			M	\$ 749.84	\$ 827.31	\$1057.81	\$1131.87
1			72" (1829mm)	72" (1829mm)	TYRA-3672-			M	790.40	871.11	1114.45	1198.59
1			84" (2134mm)	84" (2134mm)	TYRA-3684-			M	830.96	914.91	1171.09	1265.31
1			96" (2438mm)	96" (2438mm)	TYRA-3696-			M	871.52	958.71	1227.73	1332.03
1			108" (2743mm)	84" (2134mm)	TYRA-36A8-			M	912.08	1002.51	1284.37	1398.75
1			120" (3048mm)	96" (2438mm)	TYRA-36C0-			M	952.64	1046.31	1341.01	1465.47
1		42" (1067mm)	60" (1524mm)	60" (1524mm)	TYRA-4260-			M	\$ 776.88	\$ 856.51	\$1095.57	\$1176.35
1			72" (1829mm)	72" (1829mm)	TYRA-4272-			M	830.96	914.91	1171.09	1265.31
1			84" (2134mm)	84" (2134mm)	TYRA-4284-			M	871.52	958.71	1227.73	1332.03
1			96" (2438mm)	96" (2438mm)	TYRA-4296-			M	925.60	1017.11	1303.25	1420.99
1			108" (2743mm)	84" (2134mm)	TYRA-42A8-			M	1090.96	1185.71	1484.69	1612.51
1			120" (3048mm)	96" (2438mm)	TYRA-42C0-			M	1145.04	1244.11	1560.21	1701.47

Cultivate Tops – For use with Storage

Top - For use with Storage

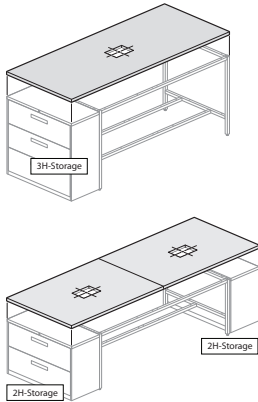

TYRA-LJSN
TYRA-WKSN
TYRA-LJMN
TYRA-WKMN

Features

- Includes pre-drilled 1 3/16" (30mm) or 2" (51mm) thick top. Two-piece top comes with attachment hardware.
- Laminate top with 3mm edgeband or wood veneer top with 3mm wood edgeband.
- Table top seams on two-piece tops:
–1 3/16" (30mm) thick tops have 1mm edgeband seam
–2" (51mm) thick tops have a 3mm edgeband seam

Specification Tips

- Tops are allowed to overhang the frame. See Specification Guide for guidelines.
- Overhang of 19" (483mm) require storage support.
- Cutouts are optional. If specified they are factory installed.
- Each cutout requires a separately specified Flush Mounted or Flip Top Double-Sided Unit power module.
- All other power options require field modification.
- Tops are dimensioned to be used with X Series 18.75" (457mm) depth with 36" (914mm) or 42" (1067mm) width, 2H for seated height. 3H for standing height.
- Storage on 1 side has 19" (483mm) overhang and the other side is flush to frame. Storage on 2 side has 19" (483mm) overhang on each side.
- Separately specified:
–Frame
–Storage
–Horizontal and Vertical Wire Management
–Power and Data Components
–Accessories

To Order, Specify:

1) Product number, including:

1 Surface Option:

- L** Laminate
- W** Wood

2 Edge Option:

- J** Edgeband (Laminate)
- K** Edgeband (Wood)

3 Cutout Option:

- N** No Cutout
- X** Center, Flush Mount Power/4 ports, add \$33.13 list
- Z** Center, Flush Mount Power/6 ports, add \$33.13 list
- M** Center, Flip Top Double-Sided/8 ports, add \$33.13 list
- Q** Center, Flip Top Double-Sided/12 ports, add \$31.13 list

2) Laminate surface color or Wood surface color.

3) Edge trim color (laminite only).

No. of Pieces	Seating Capacity	Depth	Top Width	Pre-drilled for Frame Width	Number	1	2	3	Laminate A	B	Wood Group A	Group B
Storage on 1 side		1 3/16" (30mm) Thick Top										
1		36"(914mm)	79"(2007mm)	60"(1524mm)	TYRA-3679-			S	\$ 401.44	\$ 484.31	\$ 736.21	\$ 827.07
1			91"(2311mm)	72"(1829mm)	TYRA-3691-			S	442.00	528.11	792.85	893.79
1			103"(2616mm)	84"(2134mm)	TYRA-36A3-			S	482.56	571.91	849.49	960.51
1			115"(2921mm)	96"(2438mm)	TYRA-36B5-			S	523.12	615.71	906.13	1027.23
1		42"(1067mm)	79"(2007mm)	60"(1524mm)	TYRA-4279-			S	\$ 442.00	\$ 528.11	\$ 792.85	\$ 893.79
1			91"(2311mm)	72"(1829mm)	TYRA-4291-			S	496.08	586.51	868.37	982.75
1			103"(2616mm)	84"(2134mm)	TYRA-42A3-			S	536.64	630.31	925.01	1049.47
1			115"(2921mm)	96"(2438mm)	TYRA-42B5-			S	715.52	813.51	1125.33	1263.23
Storage on 1 side		2" (51mm) Thick Top										
1		36"(914mm)	79"(2007mm)	60"(1524mm)	TYRA-3679-			M	\$ 817.44	\$ 900.31	\$ 1152.21	\$ 1243.07
1			91"(2311mm)	72"(1829mm)	TYRA-3691-			M	858.00	944.11	1208.85	1309.79
1			103"(2616mm)	84"(2134mm)	TYRA-36A3-			M	898.56	987.91	1265.49	1376.51
1			115"(2921mm)	96"(2438mm)	TYRA-36B5-			M	939.12	1031.71	1322.13	1443.23
1		42"(1067mm)	79"(2007mm)	60"(1524mm)	TYRA-4279-			M	\$ 858.00	\$ 944.11	\$ 1208.85	\$ 1309.79
1			91"(2311mm)	72"(1829mm)	TYRA-4291-			M	912.08	1002.51	1284.37	1398.75
1			103"(2616mm)	84"(2134mm)	TYRA-42A3-			M	952.64	1046.31	1341.01	1465.47
1			115"(2921mm)	96"(2438mm)	TYRA-42B5-			M	1131.52	1229.51	1541.33	1679.23
Storage on 2 sides		1 3/16" (30mm) Thick Top										
1		36"(914mm)	98"(2489mm)	60"(1524mm)	TYRA-3698-			S	\$ 455.52	\$ 542.71	\$ 811.73	\$ 916.03
1			110"(2794mm)	72"(1829mm)	TYRA-36B0-			S	496.08	586.51	868.37	982.75
2			122"(3099mm)	84"(2134mm)	TYRA-36C2-			S	640.64	734.31	1029.01	1153.47
2			134"(3404mm)	96"(2438mm)	TYRA-36D4-			S	681.20	778.11	1085.65	1220.19
1		42"(1067mm)	98"(2489mm)	60"(1524mm)	TYRA-4298-			S	\$ 523.12	\$ 615.71	\$ 906.13	\$ 1027.23
1			110"(2794mm)	72"(1829mm)	TYRA-42B0-			S	688.48	784.31	1087.57	1218.75
2			122"(3099mm)	84"(2134mm)	TYRA-42A3-			S	846.56	946.71	1267.09	1411.71
2			134"(3404mm)	96"(2438mm)	TYRA-42D4-			S	887.12	990.51	1323.73	1478.43
Storage on 2 sides		2" (51mm) Thick Top										
1		36"(914mm)	98"(2489mm)	60"(1524mm)	TYRA-3698-			M	\$ 871.52	\$ 958.71	\$ 1227.73	\$ 1332.03
1			110"(2794mm)	72"(1829mm)	TYRA-36B0-			M	912.08	1002.51	1284.37	1398.75
2			122"(3099mm)	84"(2134mm)	TYRA-36C2-			M	1259.44	1353.11	1647.81	1772.27
2			134"(3404mm)	96"(2438mm)	TYRA-36D4-			M	1300.00	1396.91	1704.45	1838.99
1		42"(1067mm)	98"(2489mm)	60"(1524mm)	TYRA-4298-			M	\$ 939.12	\$ 1031.71	\$ 1322.13	\$ 1443.23
1			91"(2311mm)	72"(1829mm)	TYRA-42B0-			M	1104.48	1200.31	1503.57	1634.75
2			122"(3099mm)	84"(2134mm)	TYRA-42A3-			M	1465.36	1565.51	1885.89	2030.51
2			134"(3404mm)	96"(2438mm)	TYRA-42D4-			M	1505.92	1609.31	1942.53	2097.23

Cultivate Frames

Frame

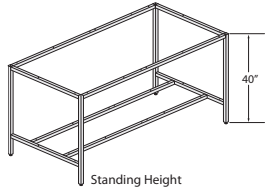
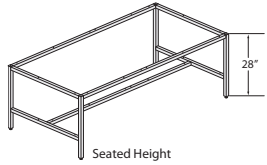

TYBA-NNNNNG4A
TYBA-NNNNNG7A

Height	Depth	Width	Number	Trim A	B	
Seated Height						
28"(711mm)	36"(914mm)	60"(1524mm)	TYBA-3660-NNNNNG4A	\$1288.56	\$1330.16	
		72"(1829mm)	TYBA-3672-NNNNNG4A	1363.44	1405.04	
		84"(2134mm)	TYBA-3684-NNNNNG4A	1438.32	1479.92	
		96"(2438mm)	TYBA-3696-NNNNNG4A	1513.20	1554.80	
42"(1067mm)	60"(1524mm)	60"(1524mm)	TYBA-4260-NNNNNG4A	\$1319.76	\$1361.36	
		72"(1829mm)	TYBA-4272-NNNNNG4A	1394.64	1436.24	
		84"(2134mm)	TYBA-4284-NNNNNG4A	1469.52	1511.12	
		96"(2438mm)	TYBA-4296-NNNNNG4A	1544.40	1586.00	
Standing Height						
40"(1016mm)	36"(914mm)	60"(1524mm)	TYBA-3660-NNNNNG7A	\$1500.72	\$1542.32	
		72"(1829mm)	TYBA-3672-NNNNNG7A	1575.60	1617.20	
		84"(2134mm)	TYBA-3684-NNNNNG7A	1650.48	1692.08	
		96"(2438mm)	TYBA-3696-NNNNNG7A	1725.36	1766.96	
	42"(1067mm)	60"(1524mm)	60"(1524mm)	TYBA-4260-NNNNNG7A	\$1531.92	\$1573.52
			72"(1829mm)	TYBA-4272-NNNNNG7A	1606.80	1648.40
			84"(2134mm)	TYBA-4284-NNNNNG7A	1681.68	1723.28
			96"(2438mm)	TYBA-4296-NNNNNG7A	1756.56	1798.16

Features

- Includes painted metal frame with two fixed-height leg assemblies, foot rail(s), support beam and attachment hardware.
- Seated height frame is standard with one foot rail.
- Standing height frame is standard with two foot rails.
- Glide adjustment 1 3/16"(30mm).

To Order, Specify:

- 1) Product number.
- 2) Frame finish.

Specification Tips

- Tops are allowed to overhang the frame. 18"(457mm) maximum overhang per side on width or depth is allowed. See specification Guide for guidelines.
- Separately specified:
 - Top
 - Storage
 - Horizontal and Vertical Wire Management
 - Power and Data Components
 - Accessories
- Structural frame provides a foundation for COM options, contact Tailored Solutions for feasibility.

Cultivate Bag Hook

Bag Hook

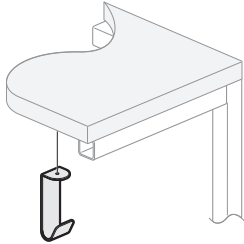

KUWH-0202

Features

- Includes one hook and attachment hardware.
- Hook will swivel if plastic washers are installed.

Specification Tips

- Attaches to the bottom of the 1 3/16"(30mm) and 2"(51mm) thick top.
- Weight Limit 50 lbs max.

Number	Trim A	B
KUWH-0202	\$41.90	\$47.41

To Order, Specify:

- 1) Product number.
- 2) Trim color.

Cultivate Power Module Clips and Brackets

	Width	Height	Number	Price
Mounting Clip for Flip Top Unit	0.5"(1mm)	2"(51mm)	EUMC-0201	\$112.52

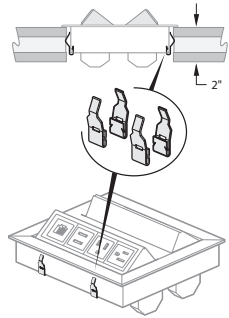

EUMC-0201
Class YA – GSA: Open Market

- Features**
- Includes twelve brackets.
 - For mounting Flip Top Unit in 2"(51mm) hollow core top.
 - Four brackets required per Flip Top Unit.

- To Order, Specify:**
- 1) Product number.
(No finish specification required.)

- Specification Tip**
- Required for Flip Top Unit on the 2"(51mm) core worksurface.

	Height	Width	Length	Description	Number	Price
Mounting Bracket for Enhanced Power Modules	1 3/4"(44mm)	2"(51mm)	3 3/8"(86mm)	Black Bracket	EUDB-0000-BB	\$62.62
				White Bracket	EUDB-0000-BW	\$62.62

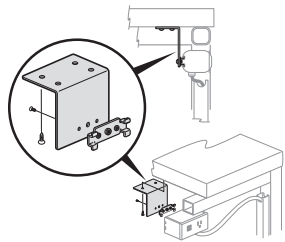

EUDB-0000
Class YA – GSA: Open Market

- Features**
- Includes bracket and mounting hardware.
 - For use with 3, 4 or 6 port Enhanced Power Modules or 2, 3, 4 and 5 port Seamless Enhanced Power Modules.
 - Available in black or white.
 - Mounts to the bottom of worksurface placing face of an Enhanced Power Module below perimeter tubing.

- To Order, Specify:**
- 1) Product number.
(No finish specification required.)

- Specification Tips**
- Specify Enhanced Power Module separately.
 - Requires field installation.
 - Application may require approval of local authority having jurisdiction (AHJ); ensure compliance before placing orders and installation.

	Width	Height	Number	Price
workware Interface Module Mounting Bracket for 2"(51mm) tops	.05"(1mm)	6"(152mm)	EWWW-0601-P	\$37.32

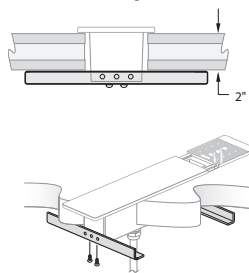

EWWW-0601
Class TK – GSA: Open Market

- Feature**
- Includes two painted steel brackets and hardware for mounting workware interface to 2"(mm) thick top.

- To Order, Specify:**
- 1) Product number.
(No finish specification required.)

- Specification Tips**
- Required for workware interface module installation on the 2"(51mm) core worksurface.
 - Reference workware book for compatible components.

Cultivate Wire Management

	Width	Number	Price
Wire Management Basket	18"(457mm)	TAWB-0918	\$127.47
	24"(610mm)	TAWB-0924	133.92
	36"(914mm)	TAWB-0936	146.76

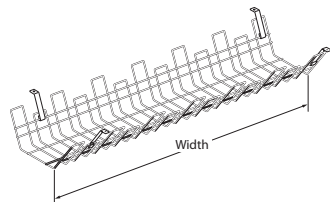

TAWB
Class TA – GSA: Open Market

Features

- Includes one basket, four brackets and attachment hardware.
- Standard in black.
- Basket is 8.5"(203mm) deep x 3.5"(76mm) high. With mounting hardware overall height is 4.94"(102mm) and depth is 10.82"(254mm).
- Accessible from both sides.
- Basket detaches without tools.

To Order, Specify:

- 1) Product number.
(No finish specification required.)

Specification Tips

- Verify mounting clearance with table understructure.
- Separately specify covers.

	Width	Number	Price
Basket Cover	18"(457mm)	TABC-0918	\$37.49
	24"(610mm)	TABC-0924	50.38
	36"(914mm)	TABC-0936	\$76.08

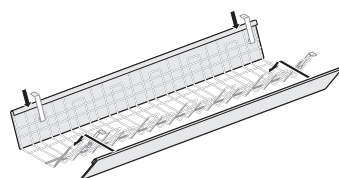

TABC (Two covers shown)
Class TA – GSA: Open Market

Feature

- Includes one painted cover.

To Order, Specify:

- 1) Product number.
- 2) Trim color.

Specification Tips

- Designed to be used with wire management basket. Up to two can be installed.
- Order to match wire management basket width.

Note: \$11.78 upcharge list for Metallic and Accent trim colors.

Vertical Wire Channel - Leg Attached	For Use With	Height	Width	Number	Trim	
					A	B
	28" Frame	25.7"(635mm)	1.17"(25mm)	TYVW-2601-P	\$79.44	\$84.12
	40" Frame	37.7"(940mm)	1.17"(25mm)	TYVW-3801-P	\$83.59	\$90.37

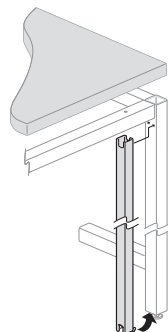

TYVW
Class CL – GSA: Open Market

Feature

- Includes wire manager and attachment screws.

To Order, Specify:

- 1) Product number.
- 2) Trim color.

Specification Tips

- Order correct model for table height.
- Add additional Vertical Wire Channels if cord number exceeds three cords.
- Accommodates 2-3 cords/cables (depending on cable diameter) or one 1/2" Flexible Conduit.

This page intentionally blank

Executive

This page intentionally blank

Executive Conference Buffet

	Height	Depth	Width	Number	①	②	③	Wood Group B	D
Conference Buffet — Wood	36 3/8"(924mm)	22"(559mm)	72"(1829mm)	TECB-2272-W	S	G6		\$9891.65	\$10920.78

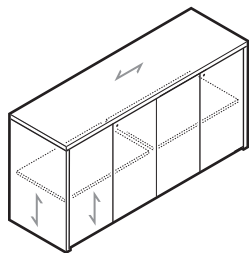

TECB

Note: ↘ = Wood Grain Direction

Features

- Includes wood veneer top with storage.
- 1 1/2"(38mm) thick wood veneer top with choice of four profile edges: –Square (1), Bevel (2), Chamfer (3) or Radius (4) on three edges with square edge on back.
- Matched veneer across doors.
- Single panel construction with four touch latch doors with concealed hinges.
- Includes two adjustable shelves with 1 1/4"(32mm) adjustment range.
- Optional Locks are available in black or chrome.
- Lock plug(s) and key(s) are shipped with random numbering unless they are specified "keyed-alike" or "master-keyed".
- Center Drawer available; separately specified.
- Glides provide 1"(25mm) adjustment range.
- Shipped assembled.

To Order, Specify:

1) Product number, including:

① Edge Option:

- 1** Square
- 2** Bevel
- 3** Chamfer
- 4** Radius

② Lock Option:

- L** Lock, add **\$140.20** list
- N** No Lock

③ Lock Color Option:

- BL** Black
- BP** Chrome

2) Wood finish color.

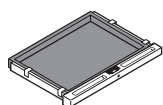
Center Drawer

UXCD-N

	Height	Depth	Width	Number	①	Wood Group B
	1 7/8"(48mm)	17 1/2"(445mm)	24"(610mm)	UXCD-1824-		\$453.43

Features

- Includes center drawer and attachment hardware.
- Hardwood front rail with routed pencil channels.
- Drawer body in black miterfold.
- Optional lock available in black or chrome.
- Lock options; refer to Lock Program Price List.
- Field installation required.

Specification Tip

- For use within Conference Buffet.

To Order, Specify:

1) Product number, including:

① Lock Option:

- L** Lock, add **\$58.47** list
- N** No Lock

2) Wood finish color (Group B veneer only).

3) Trim color for lock plug.

Executive Wood Tables Specifications

Construction Features

- One piece tops (36"-120"[914mm-3048mm] widths) are constructed with 1 1/2"(38mm) fiber board substrate with solid wood segmented edges.
- Two piece tops (132"-240"[3353mm-6096mm] widths) are constructed with 1 1/2"(38mm) fiber board substrate with solid wood segmented edges and tight joint fasteners. The tops are field joint built to go together.
- All base heights are 28"(711mm).
- All finished table heights are 29 1/2"(749mm).
- Solid wood edges are constructed of the same species as the veneer specified on the tops and are applied to tops in segments.
- 2 3/4"(70mm) thick edges (Bullnose Smooth and Bullnose Notched) are build-up construction with mitered corners;
- 1 1/2"(38mm) thick edges are solid core construction with butt joint corners. Refer to Edge Details.
- Dimensions are actual, however the tables are natural wood and dimensional variance is $\pm 1/4"$ (6mm) per top.

Wood/Finish Features

- All exposed veneers are plain-sliced and book-and center-matched (excludes patterns). Veneer for patterns is Quarter Cut.
- Executive Wood Tables feature AWI (Architectural Woodwork Institute) Grade AA tops. They are finished with a hand-applied, water-based finish. Refer to Finish Matrix.
- Executive Wood Tables are designed for non-dining applications; it is highly recommended that a protective accessory be used on table tops when possible.

Pattern and Border Options

- Diamond (R) or Reverse Diamond (V) pattern options are available on Round tops only and Box (R) or Reverse Box (V) pattern options are available on Square tops only.
- Sunburst (B) pattern option is available on Round tops only.
- Border (O) with inlay option is available on all tops.

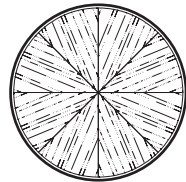

Option B
Sunburst

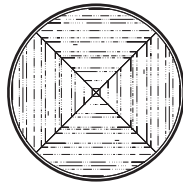

Option R
Diamond

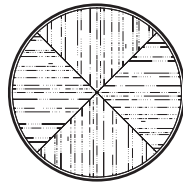

Option V
Reverse Diamond

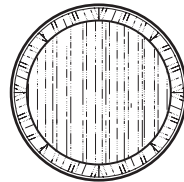

Option O
Border Inlay

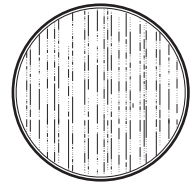

Option N
None

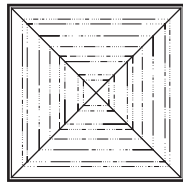

Option R
Box

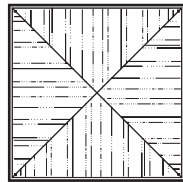

Option V
Reverse Box

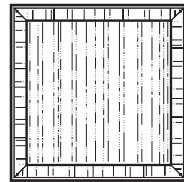

Option O
Border Inlay

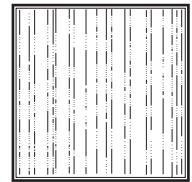

Option N
None

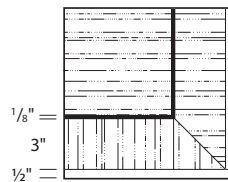

1 1/2"(38mm) edge and Border with Inlay Option (O) and butt joint corner construction.

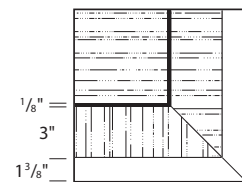

2 3/4"(70mm) edge and Border with Inlay Option (O) and mitered corner construction.

Edge Detail

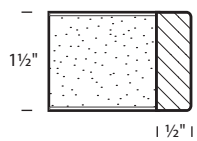

Square (1)

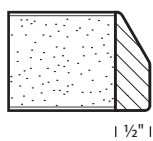

Bevel (2)

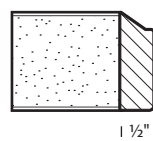

Chamfer (3)

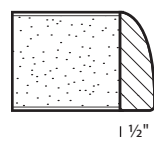

Radius (4)

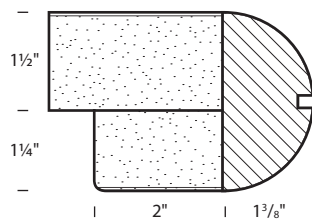

Bullnose Notched (5)

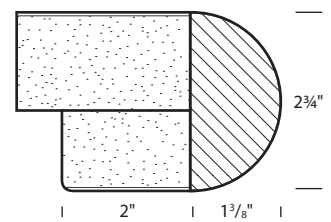

Bullnose Smooth (6)

Executive Wood Tables Specifications

Flip Top Unit Cutout Locations

One-piece tables are available with a single centered cutout option. If a centered flip top unit cutout is specified, the cutout is located at half the length and half the depth of the table top.

Two-piece tables are available with a dual left and right cutout option, which is located at half the depth and one-third the length from both ends. The cutout is sized for a dual-sided flip top unit, which is specified separately.

Each cutout is for one 12-port Double-Sided Flip Top Unit.

Tables: Centered Cutout

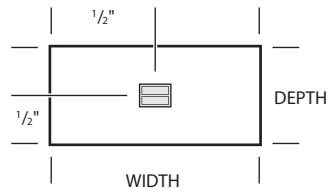

Tables: Left/Right Cutout

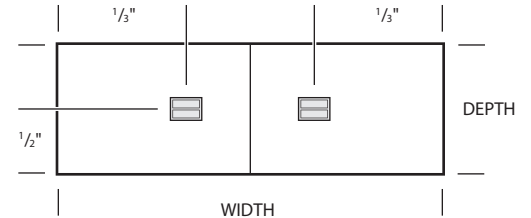

Examples:

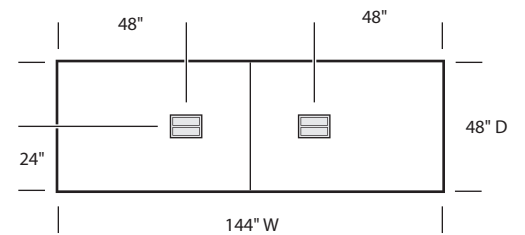
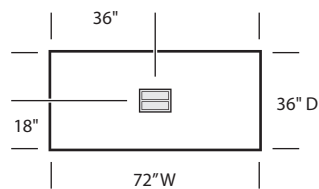

Steps to Specify an Executive Wood Table

- (1) Top
 - Shape
 - Size
 - Edge Option
 - Cutout Option for Flip Top Unit
 - Pattern or Border Option
 - Finish Option
- (2) Base Type
 - Access Door Option
 - Finish for Wood or Trim Color for Metal
- (3) Power
 - Flip Top Unit (separately specified)

On site measurements should be taken to ensure there is adequate room in elevators and/or hallway conditions to accommodate the table size.

Executive Wood Tables Catalog Logic

Executive Wood Table Tops

<p>T</p> <hr style="border: 0.5px solid black;"/>	<p>E</p> <hr style="border: 0.5px solid black;"/>	<p>RA</p> <hr style="border: 0.5px solid black;"/>	<p>-</p> <hr style="border: 0.5px solid black;"/>	<p>48</p> <hr style="border: 0.5px solid black;"/>	<p>CO</p> <hr style="border: 0.5px solid black;"/>	<p>-</p> <hr style="border: 0.5px solid black;"/>	<p>W</p> <hr style="border: 0.5px solid black;"/>	<p>2</p> <hr style="border: 0.5px solid black;"/>	<p>T</p> <hr style="border: 0.5px solid black;"/>	<p>N</p> <hr style="border: 0.5px solid black;"/>	<p>O</p> <hr style="border: 0.5px solid black;"/>
<p>Border/Pattern: B – Sunburst (Round Top Only) N – No Border or Pattern O – Border R – Round Top: Diamond, Square Top: Box V – Round Top: Reverse Diamond, Square Top: Reverse Box</p>											
<p>Cutout: S – Single Centered Cutout for 12-port Double-Sided Flip Top Unit. D – Two Cutouts, Left/Right for 12-port Double-Sided Flip Top Unit. N – No Cutout</p>											
<p>Top: K – Build-up Top T – Solid Top</p>											
<p>Edge: 1 – Square 2 – Bevel 3 – Chamfer 4 – Radius 5 – Bullnose Notched 6 – Bullnose Smooth</p>											
<p>Material: W – Wood</p>											
<p>Width: 36" – 36" C0 – 120" 42" – 42" D2 – 132" 48" – 48" E4 – 134" 54" – 54" F6 – 156" 60" – 60" G8 – 168" 66" – 66" J0 – 180" 72" – 72" K2 – 192" 78" – 78" L4 – 204" 84" – 84" M6 – 216" 96" – 96" N8 – 228" A8" – 108" Q0 – 240"</p>											
<p>Depth: 36" – 36" 42" – 42" 48" – 48" 54" – 54" 60" – 60"</p>											
<p>Shape: BO – Boat RA – Rectangle RN – Round RQ – Square RT – Racetrack WE – Wedge</p>											
<p>Platform: E – Executive Conference Tables</p>											

Product Type:
 T – Tables

Executive Wood Tables Catalog Logic

'Half Cylinder, Full Cylinder, and X Bases

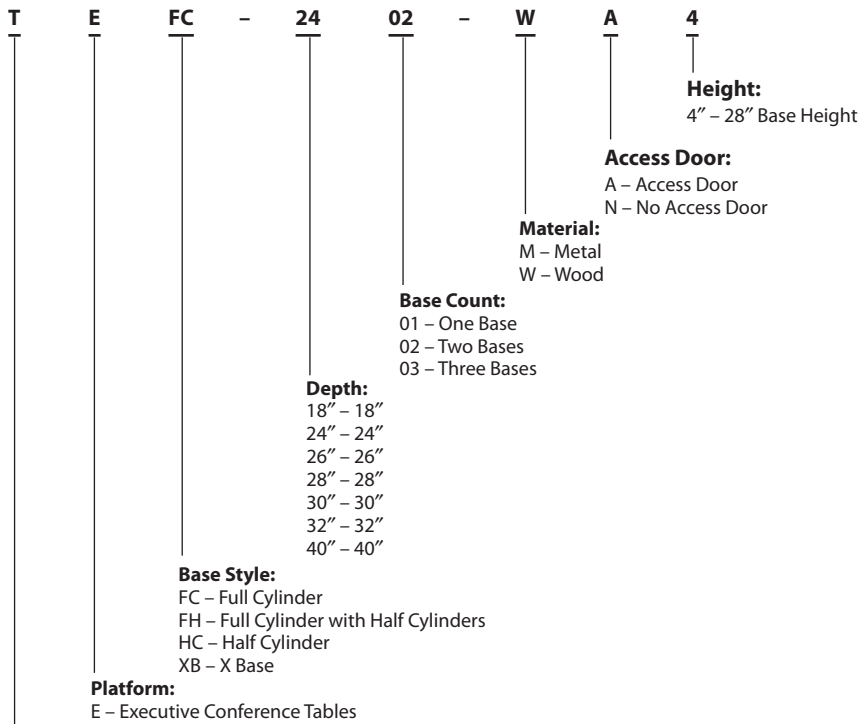

Product Type:

T – Tables

Slab Base

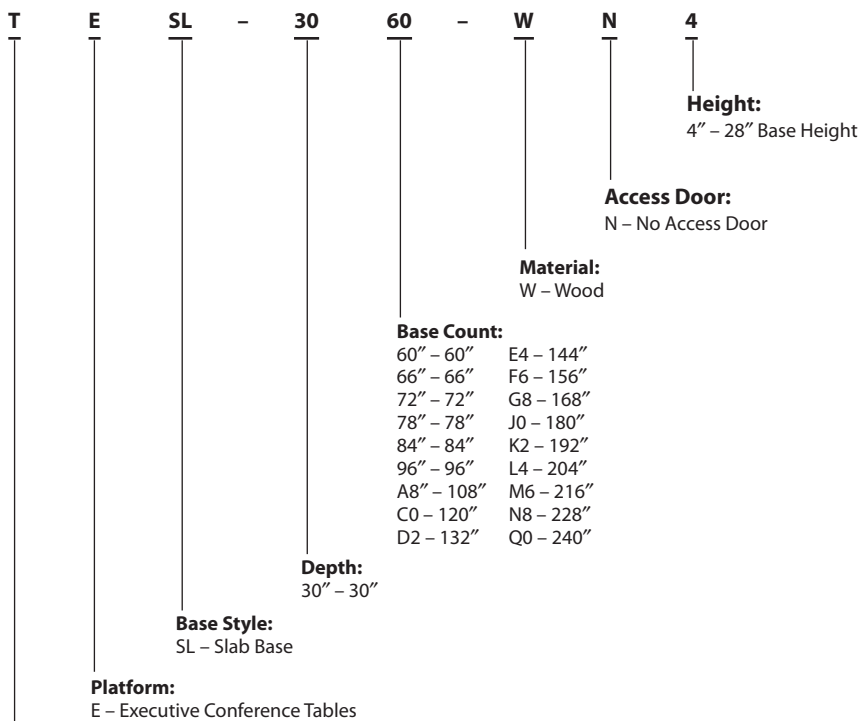

Product Type:

T – Tables

Executive Wood Tables Catalog Logic

Conference Buffet

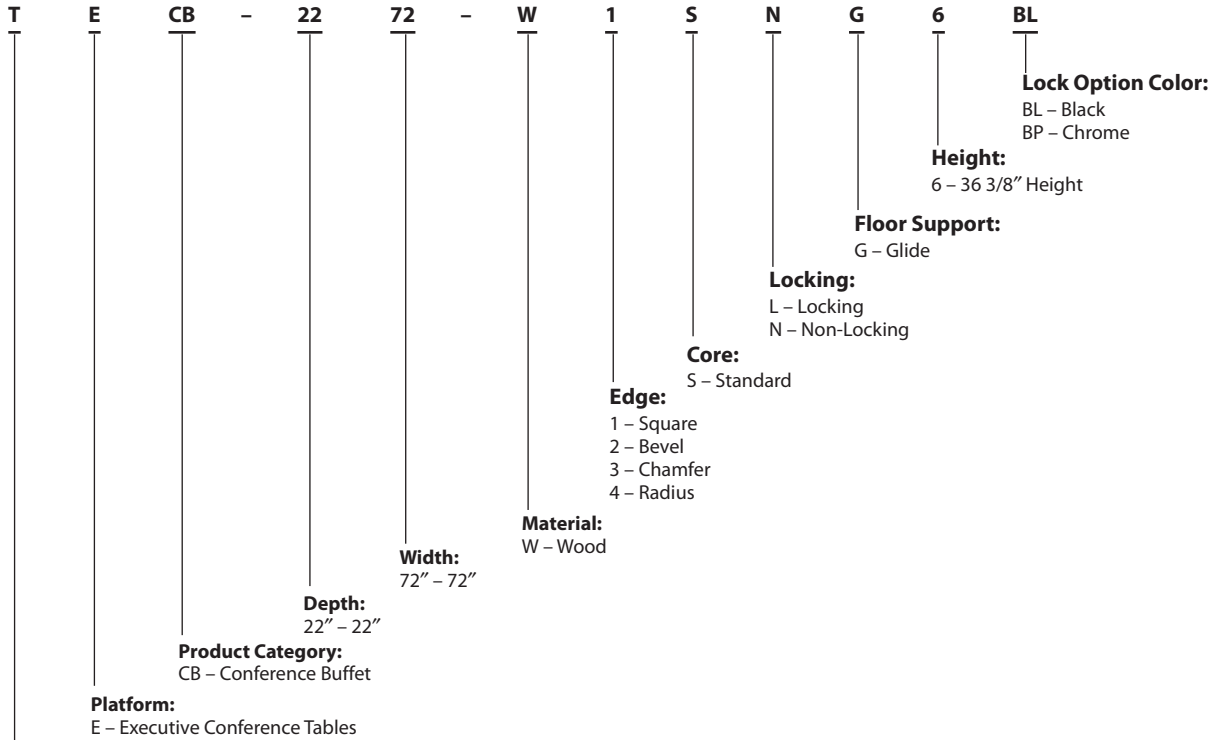

Presentation Board

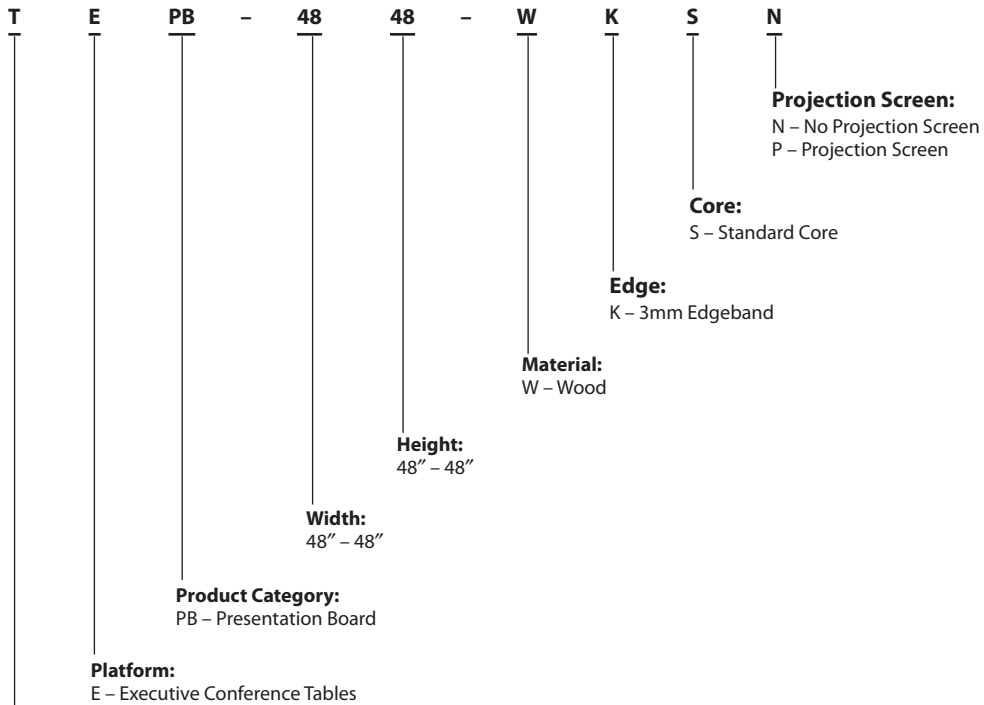

Executive Wood Tables Statement of Line

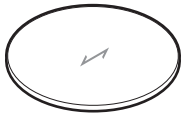

Round Table Dimensions

	36"	42"	48"	54"	60"
36"	X				
42"		X			
48"			X		
54"				X	
60"					X

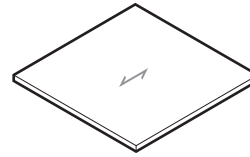

Square Table Dimensions

	36"	42"	48"	54"	60"
36"	X				
42"		X			
48"			X		
54"				X	
60"					X

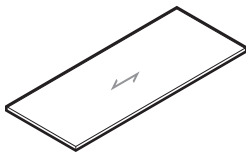

Rectangle Table Dimensions

Depth	Width	60"	66"	72"	78"	84"	96"	108"	120"	132"	144"	156"	168"	180"	192"	204"	216"	228"	240"
36"	X	X	X	X	X														
42"				X	X	X	X	X	X	X	X	X	X	X	X	X	X	X	X
48"					X	X	X	X	X	X	X	X	X	X	X	X	X	X	X
54"								X	X	X	X	X	X	X	X	X	X	X	X
60"								X	X	X	X	X	X	X	X	X	X	X	X

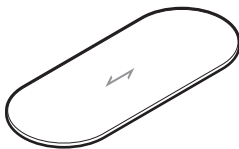

Racetrack Table Dimensions

Depth	Width	60"	66"	72"	78"	84"	96"	108"	120"	132"	144"	156"	168"	180"	192"	204"	216"	228"	240"
36"	X	X	X	X	X														
42"				X	X	X	X	X											
48"					X	X	X	X	X	X	X	X	X	X	X	X	X	X	X
54"								X	X	X	X	X	X	X	X	X	X	X	X
60"								X	X	X	X	X	X	X	X	X	X	X	X

Note: ↗ = Wood Grain Direction

Executive Wood Tables Statement of Line

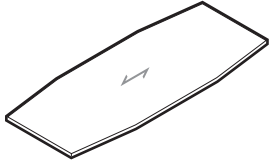

Boat Table Dimensions

Depth Width

	60"	66"	72"	78"	84"	96"	108"	120"	132"	144"	156"	168"	180"	192"	204"	216"	228"	240"
36"	X	X	X	X	X													
42"				X	X	X	X	X										
48"					X	X	X	X	X	X	X	X	X	X	X	X	X	X
54"							X	X	X	X	X	X	X	X	X	X	X	X
60"							X	X	X	X	X	X	X	X	X	X	X	X

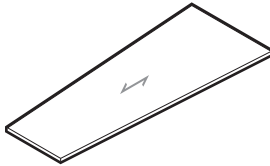

Wedge Table Dimensions

Depth

	84"	96"	108"	120"	132"	144"	156"	168"	180"	192"	204"	216"	228"	240"
48"	X	X	X	X	X	X	X	X	X	X	X	X	X	X
54"			X	X	X	X	X	X	X	X	X	X	X	X
60"			X	X	X	X	X	X	X	X	X	X	X	X

Note: ↙ = Wood Grain Direction

Executive Wood Tables Statement of Line

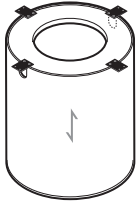

Full Cylinder
18", 24", 30" Diameter

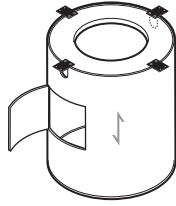

Full Cylinder with Optional Access Door



Half Cylinder
18", 24", 30"

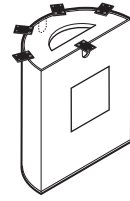

Half Cylinder with Optional Access Door

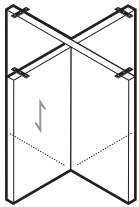

X Base
1 1/4" Thick
26", 32" Lengths

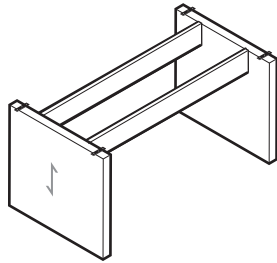

Slab Base
2" Thick
30" Long

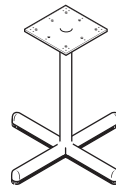

Metal X Base
28", 40"

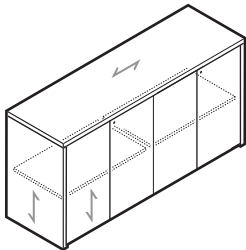

Conference Buffet

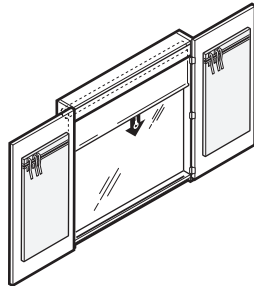

Presentation Board

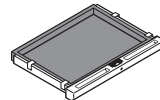

Center Drawer

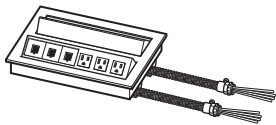

Flip Top Units

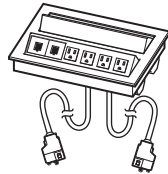

Vertical Manager — Vertical

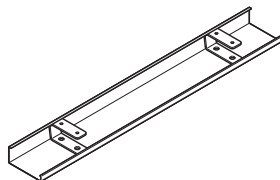

Wire Manager — Horizontal

Note: ↴ = Wood Grain Direction

Executive Wood Tables Base Placement

Base Placement

Slab Base

- 60"-78"(1524mm-1981mm) wide top base placement spacing is 12"(305mm) from ends.
- Greater than 78"(1981mm) wide top base placement spacing is 24"(610mm) from ends.
- Keel between slab base panels is 6"(152mm) tall and inset 7"(178mm) from the edge of the panels.

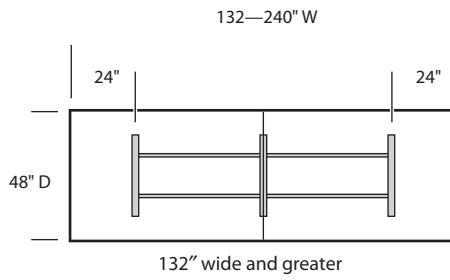
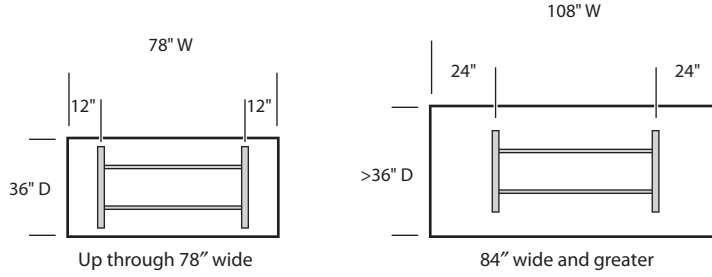

Cylinder, Half Cylinder and X Base

- $\frac{\text{Top depth} = \text{base inset}}{2}$

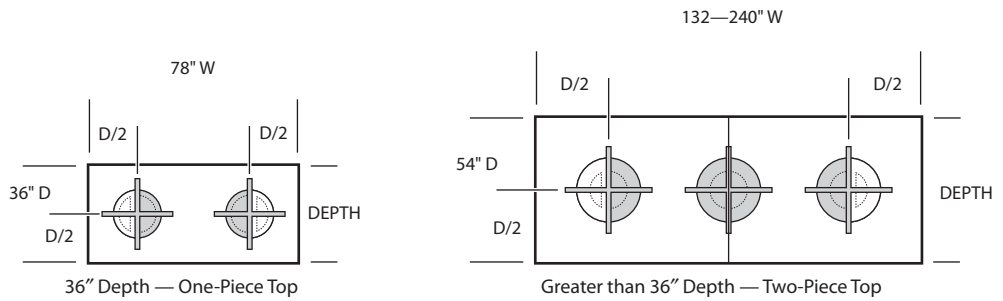

Executive Wood Tables

Size	Number	① ② ③	Wood Group		Pattern/Border Upcharges		Reverse Diamond/ Reverse Box (V)	Border (O)	
			B	D	Sunburst (B)	Diamond/Box (R)			
1 1/2" (38mm) Edge — Round									
36" (914mm)	TERN-3636-W	T		\$ 2189.19	\$ 2568.71	\$ 871.70	\$ 678.58	\$ 662.70	\$1994.32
42" (1067mm)	TERN-4242-W	T		2544.94	3036.30	1186.53	899.48	899.48	2241.72
48" (1219mm)	TERN-4848-W	T		2950.99	3570.03	1555.59	1175.94	1175.94	2489.15
54" (1372mm)	TERN-5454-W	T		3407.34	4169.90	2515.90	1484.15	1484.15	2736.57
60" (1524mm)	TERN-6060-W	T		3913.99	4835.91	3100.58	1832.04	1832.04	2977.94
2 3/4" (70mm) Edge									
36" (914mm)	TERN-3636-W	K		\$ 4848.87	\$ 5218.31	\$ 871.70	\$ 678.58	\$ 662.70	\$1994.32
42" (1067mm)	TERN-4242-W	K		5647.90	6127.50	1186.53	899.48	899.48	2241.72
48" (1219mm)	TERN-4848-W	K		8216.83	8822.43	1555.59	1175.94	1175.94	2489.15
54" (1372mm)	TERN-5454-W	K		9116.46	9863.90	2515.90	1484.15	1484.15	2736.57
60" (1524mm)	TERN-6060-W	K		10066.39	10971.51	3100.58	1832.04	1832.04	2977.94
1 1/2" (38mm) Edge — Square									
36" x 36" (914mm x 914mm)	TERQ-3636-W	T		\$ 1880.46	\$ 1963.79	N/A	\$ 662.70	\$ 662.70	\$ 672.35
42" x 42" (1067mm x 1067mm)	TERQ-4242-W	T		2255.88	2425.14	N/A	899.48	899.48	785.40
48" x 48" (1219mm x 1219mm)	TERQ-4848-W	T		2684.22	2952.63	N/A	1175.94	1175.94	898.45
54" x 54" (1372mm x 1372mm)	TERQ-5454-W	T		3165.48	3546.26	N/A	1484.15	1484.15	1011.50
60" x 60" (1524mm x 1524mm)	TERQ-6060-W	T		3699.66	4206.03	N/A	1832.04	1832.04	1118.60
2 3/4" (70mm) Edge									
36" x 36" (914mm x 914mm)	TERQ-3636-W	K		\$ 2919.97	\$ 3196.26	N/A	\$ 662.70	\$ 662.70	\$ 672.35
42" x 42" (1067mm x 1067mm)	TERQ-4242-W	K		3319.39	3713.77	N/A	899.48	899.48	785.40
48" x 48" (1219mm x 1219mm)	TERQ-4848-W	K		5028.36	5554.05	N/A	1175.94	1175.94	898.45
54" x 54" (1372mm x 1372mm)	TERQ-5454-W	K		5533.62	6203.84	N/A	1484.15	1484.15	1011.50
60" x 60" (1524mm x 1524mm)	TERQ-6060-W	K		6091.80	6919.77	N/A	1832.04	1832.04	1118.60

Round/Square

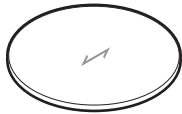

TERN

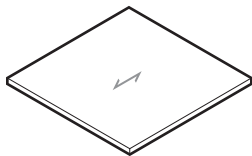

TERQ

Note: ↗ = Wood Grain Direction

Features

- Includes one piece, round or square, wood veneer top with solid wood edge:
 - 1 1/2" (38mm) Edge: Square (1), Bevel (2), Chamfer (3) or Radius (4).
 - 2 3/4" (70mm) Edge; Bullnose Notched (5) or Bullnose Smooth (6)
- Flip Top Unit Cutout Option available with Full Cylinder Base only (Flip Top Units separately specified).
- Diamond on Round or Box on Square (R) and Reverse Diamond on Round or Reverse Box on Square (V) pattern options are available.
- Sunburst (B) pattern option is available on round tops only.
- Border (O) option has black 1/8" (3mm) thick inlay.
- Base Kits are specified separately.
- Base kits include Full Cylinder, Metal X Base and Wood X Base.
- Finished table height with base is 29 1/2" (749mm).
- S Cutout - Each cutout is for one 12-port Double-Sided Flip Top Unit.

To Order, Specify:

- 1) Product number, including:

① Edge Option:

- 1 1 1/2" Square
- 2 1 1/2" Bevel
- 3 1 1/2" Chamfer
- 4 1 1/2" Radius
- 5 2 3/4" Bullnose Notched
- 6 2 3/4" Bullnose Smooth

② Flip Top Unit Cutout:

- S Single Centered, add \$259.37 list
- N None

③ Pattern/Border Options: Upcharges (list)

- B Sunburst (Round Only)
- R Diamond/Box
- V Reverse Diamond/Reverse Box
- O Border
- N None

- 2) Wood surface finish.

Executive Wood Tables

Size	Base Qty/Size	Number ①	Price	Wood Group B	D
Base Kits — Round/Square Wood Tables					
Full Cylinder Base Kit					
36"(914mm)	1-18"(457mm)	TEFC-1801-W 4		\$1792.50	\$2367.46
42"-54"(1067mm-1372mm)	1-24"(610mm)	TEFC-2401-W 4		1814.44	2396.43
60"(1524mm)	1-30"(762mm)	TEFC-3001-W 4		2011.90	2657.23
Metal X Base Kit					
36"-42"(914mm-1067mm)	1-28"(711mm)	TEXB-2801-MN4	\$419.31		
48"(1219mm)	1-40"(1016mm)	TEXB-4001-MN4	488.10		
Wood X Base Kit					
36"-42"(914mm-1067mm)	1-26"(660mm)	TEXB-2601-WN4		\$1689.17	\$2230.99
48"-60"(1219mm-1524mm)	1-32"(813mm)	TEXB-3201-WN4		1775.16	2344.54

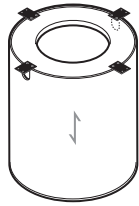

TEFC

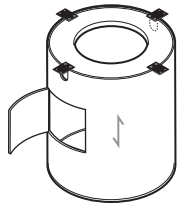

TEFC-A

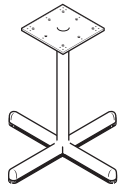

TEXB-M

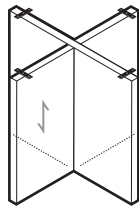

TEXB-W

Note: ↴ = Wood Grain Direction

Features

- Each kit includes one 28"(711mm) high base with attachment hardware:
 - Full Cylinder Base: Wood veneer over wood base; available with optional Access Door for power access.
 - Full Cylinder Base has cord access cutout.
 - Each Full Cylinder base includes weight for stability.
- Wood X Base: Two 26"(660mm) or 32"(813mm) deep, 1 1/4"(32mm) thick wood veneer slabs.
- X Base: two 30"(762mm) deep, 1 1/4"(32mm) thick wood veneer slabs.
- Metal X Base available in trim colors.
- Glide adjustment of 1"(25mm) on all bases.
- Cylinders ship assembled; X Bases require field assembly.

To Order, Specify:

- 1) Product number, including:

① Access Hatch Option:

- A** Access Door, add \$511.04 list
- N** No Access Door

- 2) Wood surface finish.

X Base – Wood

- 1) Product number.
- 2) Wood surface finish.

X Base – Metal

- 1) Product number
- 2) Trim colors.

Note: \$18.51 upcharge (list) for Metallic or accent trim colors.

Executive Wood Tables

Rectangular

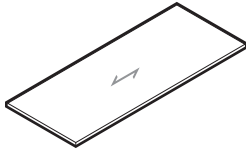

TERA
(60"-120")

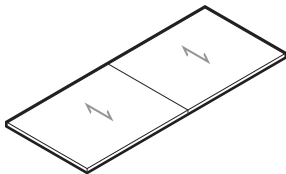

TERA
(132"-240"
[3353mm-6096mm])

Note: ↘ = Wood Grain Direction

Features

- Includes one piece (60"-120"[1524mm-3048mm] wide) or two piece (132"-240"[3353mm-6096mm] wide) Rectangular shaped wood veneer top with solid wood edge:
 - 1 1/2"(38mm) Edge: Square (1), Bevel (2), Chamfer (3) or Radius (4).
 - 2 3/4"(70mm) Edge: Bullnose Notched (5) or Bullnose Smooth (6).
- Border (O) option has black 1/8"(3mm) thick inlay.
- Base Kits are specified separately.
- Base kits include Full Cylinder, Half Cylinder, Full/Half Cylinder, Wood X Base and Wood Slab Base.
- Flip Top Unit Cutout Options available for separately specified Flip Top Unit(s) on tops greater than 36"(914mm) deep:
 - One centered cutout (S) (84"-120"[2134mm-3048mm] wide tops).
 - Two left/right cutouts (D) (132"-240"[3353mm-6096mm] wide tops).
 - Cutouts are centered between bases.

Note: On site measurements should be taken to ensure there is adequate room in elevators and/or hallway conditions to accommodate the top sizes.

Cutout options: S - One 12-port Double-Sided Flip Top Unit
D - Two 12-port Double-Sided Flip Top Units

To Order, Specify:

1) Product number, including:

1 Edge Option:

- 1 1 1/2" Square
- 2 1 1/2" Bevel
- 3 1 1/2" Chamfer
- 4 1 1/2" Radius
- 5 2 3/4" Bullnose Notched
- 6 2 3/4" Bullnose Smooth

2 Flip Top Unit Cutout:

- S Single Centered (84"-120"[2134mm-3048mm] Widths), add **\$249.39** list
- D Two Left/Right (132"-240"[3353mm-6096mm] Widths), add **\$498.79** list

N None

3 Border Option: Upcharge (list)

- N None
- O Border

2) Wood surface finish.

Depth	Width	Pieces	Number	1	2	3	Wood Group B	D	Upcharge Border Option (O)
1 1/2" (38mm) Edge									
36"(914mm)	60"(1524mm)	1	TERA-3660-W	TN			\$ 2708.35	\$ 3026.46	\$ 877.04
	66"(1676mm)	1	TERA-3666-W	TN			2948.11	3295.92	930.44
	72"(1829mm)	1	TERA-3672-W	TN			3187.87	3565.38	983.84
	78"(1981mm)	1	TERA-3678-W	TN			3427.63	3834.84	1037.24
	84"(2134mm)	1	TERA-3684-W	TN			3667.39	4104.30	1090.64
2 3/4" (70mm) Edge									
36"(914mm)	60"(1524mm)	1	TERA-3660-W	KN			\$ 4768.76	\$ 5086.87	\$ 877.04
	66"(1676mm)	1	TERA-3666-W	KN			5190.56	5538.37	930.44
	72"(1829mm)	1	TERA-3672-W	KN			5612.36	5989.87	983.84
	78"(1981mm)	1	TERA-3678-W	KN			6034.16	6441.37	1037.24
	84"(2134mm)	1	TERA-3684-W	KN			6455.96	6892.87	1090.64
1 1/2" (38mm) Edge									
42"(1067mm)	78"(1981mm)	1	TERA-4278-W	TN			\$ 3800.39	\$ 4271.95	\$ 1090.64
	84"(2134mm)	1	TERA-4284-W	T			4059.15	4565.36	1144.04
	96"(2438mm)	1	TERA-4296-W	T			4576.67	5152.18	1250.84
	108"(2743mm)	1	TERA-42A8-W	T			5094.19	5739.00	1357.64
	120"(3048mm)	1	TERA-42C0-W	T			5611.71	6325.82	1464.44
	132"(3353mm)	2	TERA-42D2-W	T			6639.70	7423.11	1689.05
	144"(3658mm)	2	TERA-42E4-W	T			7314.26	8166.97	1795.85
	156"(3962mm)	2	TERA-42F6-W	T			7988.82	8910.83	1902.65
	168"(4267mm)	2	TERA-42G8-W	T			8663.38	9654.69	2009.45
	180"(4572mm)	2	TERA-42J0-W	T			9927.23	10987.84	2181.70
	192"(4877mm)	2	TERA-42K2-W	T			10523.27	11653.18	2288.50
	204"(5182mm)	2	TERA-42L4-W	T			11119.31	12318.52	2395.30
	216"(5486mm)	2	TERA-42M6-W	T			11715.35	12983.86	2502.10
	228"(5791mm)	2	TERA-42N8-W	T			12311.39	13649.20	2608.90
	240"(6096mm)	2	TERA-42Q0-W	T			12907.43	14314.54	2715.70

Executive Wood Tables

	Depth	Width	Pieces	Number	① ② ③			Wood Group		Upcharge Border Option (O)	
					B	D					
Rectangular	2 3/4" (70mm) Edge										
	42"(1067mm)	78"(1981mm)	1	TERA-4278-W	■	KN	■	\$ 6588.96	\$ 7060.52	\$1090.64	
		84"(2134mm)	1	TERA-4284-W	■	K	■	7029.76	7535.97	1144.04	
		96"(2438mm)	1	TERA-4296-W	■	K	■	7911.36	8486.87	1250.84	
		108"(2743mm)	1	TERA-42A8-W	■	K	■	8792.96	9437.77	1357.64	
		120"(3048mm)	1	TERA-42C0-W	■	K	■	9674.56	10388.67	1464.44	
		132"(3353mm)	2	TERA-42D2-W	■	K	■	11603.38	12386.79	1689.05	
		144"(3658mm)	2	TERA-42E4-W	■	K	■	12956.22	13808.93	1795.85	
		156"(3962mm)	2	TERA-42F6-W	■	K	■	14309.06	15231.07	1902.65	
		168"(4267mm)	2	TERA-42G8-W	■	K	■	15661.90	16653.21	2009.45	
		180"(4572mm)	2	TERA-42J0-W	■	K	■	16320.98	17381.59	2181.70	
		192"(4877mm)	2	TERA-42K2-W	■	K	■	17333.46	18463.37	2288.50	
		204"(5182mm)	2	TERA-42L4-W	■	K	■	18345.94	19545.15	2395.30	
		216"(5486mm)	2	TERA-42M6-W	■	K	■	19358.42	20626.93	2502.10	
		228"(5791mm)	2	TERA-42N8-W	■	K	■	20370.90	21708.71	2608.90	
		240"(6096mm)	2	TERA-42Q0-W	■	K	■	21383.38	22790.49	2715.70	
		1 1/2" (38mm) Edge									
		48"(1219mm)	84"(2134mm)	1	TERA-4884-W	■	T	■	\$ 4450.91	\$ 5026.42	\$1197.44
			96"(2438mm)	1	TERA-4896-W	■	T	■	5006.43	5661.14	1304.24
			108"(2743mm)	1	TERA-48A8-W	■	T	■	5561.95	6295.86	1411.04
			120"(3048mm)	1	TERA-48C0-W	■	T	■	6117.47	6930.58	1517.84
			132"(3353mm)	2	TERA-48D2-W	■	T	■	7170.42	8062.73	1742.45
			144"(3658mm)	2	TERA-48E4-W	■	T	■	7725.94	8697.45	1849.25
			156"(3962mm)	2	TERA-48F6-W	■	T	■	8281.46	9332.17	1956.05
			168"(4267mm)	2	TERA-48G8-W	■	T	■	8836.98	9966.89	2062.85
			180"(4572mm)	2	TERA-48J0-W	■	T	■	10622.99	11832.10	2235.10
			192"(4877mm)	2	TERA-48K2-W	■	T	■	11257.03	12545.34	2341.90
			204"(5182mm)	2	TERA-48L4-W	■	T	■	11891.07	13258.58	2448.70
			216"(5486mm)	2	TERA-48M6-W	■	T	■	12525.11	13971.82	2555.50
			228"(5791mm)	2	TERA-48N8-W	■	T	■	13159.15	14685.06	2662.30
			240"(6096mm)	2	TERA-48Q0-W	■	T	■	13793.19	15398.30	2769.10
		2 3/4" (70mm) Edge									
		48"48"(1219mm)	84"(2134mm)	1	TERA-4884-W	■	K	■	\$ 7603.56	\$ 8179.07	\$1197.44
			96"(2438mm)	1	TERA-4896-W	■	K	■	8523.16	9177.87	1304.24
			108"(2743mm)	1	TERA-48A8-W	■	K	■	9442.76	10176.67	1411.04
			120"(3048mm)	1	TERA-48C0-W	■	K	■	10362.36	11175.47	1517.84
		132"(3353mm)	2	TERA-48D2-W	■	K	■	12028.10	12920.41	1742.45	
		144"(3658mm)	2	TERA-48E4-W	■	K	■	12947.70	13919.21	1849.25	
		156"(3962mm)	2	TERA-48F6-W	■	K	■	13867.30	14918.01	1956.05	
		168"(4267mm)	2	TERA-48G8-W	■	K	■	14786.90	15916.81	2062.85	
		180"(4572mm)	2	TERA-48J0-W	■	K	■	17329.69	18538.80	2235.10	
		192"(4877mm)	2	TERA-48K2-W	■	K	■	18471.81	19760.12	2341.90	
		204"(5182mm)	2	TERA-48L4-W	■	K	■	19613.93	20981.44	2448.70	
		216"(5486mm)	2	TERA-48M6-W	■	K	■	20756.05	22202.76	2555.50	
		228"(5791mm)	2	TERA-48N8-W	■	K	■	21898.17	23424.08	2662.30	
		240"(6096mm)	2	TERA-48Q0-W	■	K	■	23040.29	24645.40	2769.10	

Executive Wood Tables

	Depth	Width	Pieces	Number	① ② ③			Wood Group		Upcharge Border Option (O)
					B	D				
Rectangular	1 1/2" (38mm) Edge									
	54"(1372mm)	108"(2743mm)	1	TERA-54A8-W	T			\$ 6029.71	\$ 6852.72	\$1464.44
		120"(3048mm)	1	TERA-54C0-W	T			6623.23	7535.34	1571.24
		132"(3353mm)	2	TERA-54D2-W	T			7923.60	8924.81	1795.85
		144"(3658mm)	2	TERA-54E4-W	T			8595.64	9685.95	1902.65
		156"(3962mm)	2	TERA-54F6-W	T			9267.68	10447.09	2009.45
		168"(4267mm)	2	TERA-54G8-W	T			9939.72	11208.23	2116.25
		180"(4572mm)	2	TERA-54J0-W	T			11318.75	12676.36	2288.50
		192"(4877mm)	2	TERA-54K2-W	T			11990.79	13437.50	2395.30
		204"(5182mm)	2	TERA-54L4-W	T			12662.83	14198.64	2502.10
		216"(5486mm)	2	TERA-54M6-W	T			13334.87	14959.78	2608.90
		228"(5791mm)	2	TERA-54N8-W	T			14006.91	15720.92	2715.70
	240"(6096mm)	2	TERA-54Q0-W	T			14678.95	16482.06	2822.50	
	2 3/4" (70mm) Edge									
	54"(1372mm)	108"(2743mm)	1	TERA-54A8-W	K			\$10092.56	\$10915.57	\$1464.44
		120"(3048mm)	1	TERA-54C0-W	K			11050.16	11962.27	1571.24
		132"(3353mm)	2	TERA-54D2-W	K			13094.24	14095.45	1795.85
		144"(3658mm)	2	TERA-54E4-W	K			14287.46	15377.77	1902.65
		156"(3962mm)	2	TERA-54F6-W	K			15480.68	16660.09	2009.45
		168"(4267mm)	2	TERA-54G8-W	K			16673.90	17942.41	2116.25
		180"(4572mm)	2	TERA-54J0-W	K			18338.39	19696.00	2288.50
		192"(4877mm)	2	TERA-54K2-W	K			19597.05	21043.76	2395.30
		204"(5182mm)	2	TERA-54L4-W	K			20855.71	22391.52	2502.10
		216"(5486mm)	2	TERA-54M6-W	K			22114.37	23739.28	2608.90
		228"(5791mm)	2	TERA-54N8-W	K			23373.03	25087.04	2715.70
		240"(6096mm)	2	TERA-54Q0-W	K			24631.69	26434.80	2822.50
	1 1/2" (38mm) Edge									
	60"(1524mm)	108"(2743mm)	1	TERA-60A8-W	T			\$ 6497.47	\$ 7409.58	\$1517.84
		120"(3048mm)	1	TERA-60C0-W	T			7128.99	8140.10	1624.64
		132"(3353mm)	2	TERA-60D2-W	TN			8604.81	9714.92	1849.25
		144"(3658mm)	2	TERA-60E4-W	T			9314.85	10523.96	1956.05
		156"(3962mm)	2	TERA-60F6-W	T			10024.89	11333.00	2062.85
		168"(4267mm)	2	TERA-60G8-W	T			10734.93	12142.04	2169.65
		180"(4572mm)	2	TERA-60J0-W	T			11805.06	13311.17	2341.90
		192"(4877mm)	2	TERA-60K2-W	T			12515.10	14120.21	2448.70
		204"(5182mm)	2	TERA-60L4-W	T			13225.14	14929.25	2555.50
		216"(5486mm)	2	TERA-60M6-W	T			13935.18	15738.29	2662.30
		228"(5791mm)	2	TERA-60N8-W	T			14645.22	16547.33	2769.10
		240"(6096mm)	2	TERA-60Q0-W	T			15355.26	17356.37	2875.90
	2 3/4" (70mm) Edge									
	60"(1524mm)	108"(2743mm)	1	TERA-60A8-W	K			\$10742.36	\$11654.47	\$1517.84
		120"(3048mm)	1	TERA-60C0-W	K			11737.96	12749.07	1624.64
		132"(3353mm)	2	TERA-60D2-W	KN			14055.67	15165.78	1849.25
		144"(3658mm)	2	TERA-60E4-W	K			15286.89	16496.00	1956.05
		156"(3962mm)	2	TERA-60F6-W	K			16518.11	17826.22	2062.85
		168"(4267mm)	2	TERA-60G8-W	K			17749.33	19156.44	2169.65
		180"(4572mm)	2	TERA-60J0-W	K			19477.98	20984.09	2341.90
		192"(4877mm)	2	TERA-60K2-W	K			20866.26	22471.37	2448.70
		204"(5182mm)	2	TERA-60L4-W	K			22254.54	23958.65	2555.50
		216"(5486mm)	2	TERA-60M6-W	K			23642.82	25445.93	2662.30
		228"(5791mm)	2	TERA-60N8-W	K			25031.10	26933.21	2769.10
		240"(6096mm)	2	TERA-60Q0-W	K			26419.38	28420.49	2875.90

Executive Wood Tables

Rectangular Table Depths	Widths	Base Qty/Size	Number ①	Wood Group B	D
Base Kits — Rectangular Wood Tables					
Full Cylinder Base Kits					
36-42"(914mm-1067mm)	60"-120"(1524mm-3048mm)	2-18"(457mm)	TEFC-1802-W █ 4	\$3406.94	\$4499.73
42"(1067mm)	132"-240"(3353mm-6096mm)	3-18"(457mm)	TEFC-1803-W █ 4	5111.69	6751.30
48"-54"(1219mm-1372mm)	84"-120"(2134mm-3048mm)	2-24"(610mm)	TEFC-2402-W █ 4	3628.89	4792.89
	132"-240"(3353mm-6096mm)	3-24"(610mm)	TEFC-2403-W █ 4	5442.06	7187.62
60"(1524mm)	108"-120"(2743mm-3048mm)	2-30"(762mm)	TEFC-3002-W █ 4	4026.40	5317.86
	132"-240"(3353mm-6096mm)	3-30"(762mm)	TEFC-3003-W █ 4	6038.27	7975.09
Full/Half Cylinder Base Kits					
42"(1067mm)	132"-240"(3353mm-6096mm)	3-18"(457mm)	TEFH-1803-W █ 4	\$5189.13	\$6853.56
48"-54"(1219mm-1372mm)	132"-240"(3353mm-6096mm)	3-24"(610mm)	TEFH-2403-W █ 4	5476.92	7233.66
60"(1524mm)	132"-240"(3353mm-6096mm)	3-30"(762mm)	TEFH-3003-W █ 4	6070.53	8017.69
Half Cylinder Base Kits					
36-42"(914mm-1067mm)	60"-120"(1524mm-3048mm)	2-18"(457mm)	TEHC-1802-W █ 4	\$3501.36	\$4624.03
48"-54"(1219mm-1372mm)	84"-120"(2134mm-3048mm)	2-24"(610mm)	TEHC-2402-W █ 4	3653.02	4775.69
60"(1524mm)	108"-120"(2743mm-3048mm)	2-30"(762mm)	TEHC-3002-W █ 4	4078.22	5200.89
Wood X Base Kits					
36"-54"	60"-120"(1524mm-3048mm)	2-26"(660mm)	TEXB-2602-WN4	\$3379.67	\$4463.73
	132"-240"(3353mm-6096mm)	3-26"(660mm)	TEXB-2603-WN4	5068.83	6694.70
60"(1524mm)	108"-120"(2743mm-3048mm)	2-32"(813mm)	TEXB-3202-WN4	3550.30	4689.11
	132"-240"(3353mm-6096mm)	3-32"(813mm)	TEXB-3203-WN4	5325.45	7033.63
Wood Slab Base Kits					
		2-60"(1524mm)	TESL-3060-WN4	\$2468.69	\$3260.52
		2-66"(1676mm)	TESL-3066-WN4	2478.81	3273.87
		2-72"(1829mm)	TESL-3072-WN4	2488.93	3287.22
		2-78"(1981mm)	TESL-3078-WN4	2499.05	3300.57
		2-84"(2134mm)	TESL-3084-WN4	2509.17	3313.92
		2-96"(2438mm)	TESL-3096-WN4	2529.41	3340.62
		2-108"(2743mm)	TESL-30A8-WN4	2549.65	3367.32
		2-120"(3048mm)	TESL-30C0-WN4	2569.89	3394.02
		3-132"(3353mm)	TESL-30D2-WN4	4117.86	5438.68
		3-144"(3658mm)	TESL-30E4-WN4	4350.54	5746.04
		3-156"(3962mm)	TESL-30F6-WN4	4583.22	6053.40
		3-168"(4267mm)	TESL-30G8-WN4	4815.90	6360.76
		3-180"(4572mm)	TESL-30J0-WN4	5048.58	6668.12
		3-192"(4877mm)	TESL-30K2-WN4	5281.26	6975.48
		3-204"(5182mm)	TESL-30L4-WN4	5513.94	7282.84
		3-216"(5486mm)	TESL-30M6-WN4	5746.62	7590.20
		3-228"(5791mm)	TESL-30N8-WN4	5979.30	7897.56
		3-240"(6096mm)	TESL-30Q0-WN4	6211.98	8204.92

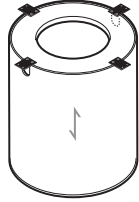

TEFC

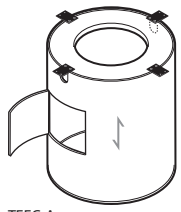

TEFH-A

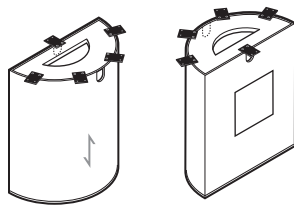

TEHC

TEHC-A

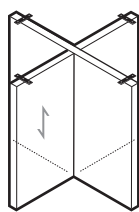

TEXB-W

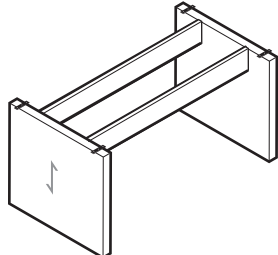

TESL

Note: ↗ = Wood Grain Direction

Features

- Each kit includes 28"(711mm) high base kit(s) with attachment hardware:
 - Full Cylinder Base: Wood veneer over wood base; available with optional Access Door for power access.
 - Full Cylinder Base and Half Cylinder Base have cord access cutout.
 - Half Cylinder Base: Wood veneer over wood base.
 - Each Full Cylinder and Half Cylinder base includes weight for stability.
- Wood X Base: Two 26"(660mm) or 32"(813mm) deep, 1 1/4"(32mm) thick wood veneer slabs.
- Slab Base: 30"(762mm) deep, 2"(51mm) thick wood veneer with Keel sets:
 - One base set includes one Keel set.
 - Three base kit includes two Keel sets.
- Glide adjustment of 1"(25mm) on all bases
- Cylinders ship assembled; other bases require field assembly.

To Order, Specify:

- 1) Product number, including:
 - ① Access Hatch Option:
 - A Access Door, upcharges (list) per kit Base Qty Two, add \$1022.08 list Base Qty Three, add \$1533.12 list
 - N No Access Door
 - 2) Wood surface finish.
- X Base/Slab Base**
- 1) Product number.
 - 2) Wood surface finish.

Executive Wood Tables

Racetrack Tables

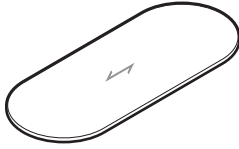
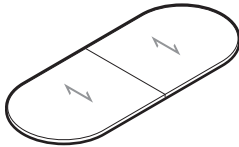
TERT
(60"-120")TERT
(132"-240"
[3353mm-6096mm])

Note: ↗ = Wood Grain Direction

Features

- Includes one piece (60"-120"[1524mm-3048mm] wide) or two piece (132"-240"[3353mm-6096mm] wide) Racetrack shaped wood veneer top with solid wood edge:
 - 1 1/2"(38mm) Edge: Square (1), Bevel (2), Chamfer (3) or Radius (4).
 - 2 3/4"(70mm) Edge: Bullnose Notched (5) or Bullnose Smooth (6).
- Border (O) option has black 1/8"(3mm) thick inlay.
- Base Kits are specified separately.
- Base kits include Full Cylinder, Half Cylinder, Full/Half Cylinder Wood X Base and Wood Slab Base.
- Flip Top Unit Cutout Options available for separately specified Flip Top Unit(s) on tops greater than 36"(914mm) deep:
 - One centered cutout (S) (84"-120"[2134mm-3048mm] wide tops).
 - Two left/right cutouts (D) (132-240"[3353mm-6096mm] wide tops).
 - Cutouts are centered between bases.

Note: On site measurements should be taken to ensure there is adequate room in elevators and/or hallway conditions to accommodate the top sizes.

Cutout options: S - One 12-port Double-Sided Flip Top Unit
D - Two 12-port Double-Sided Flip Top Units

To Order, Specify:

1) Product number, including:

① Edge Option:

- 1 1 1/2" Square
- 2 1 1/2" Bevel
- 3 1 1/2" Chamfer
- 4 1 1/2" Radius
- 5 2 3/4" Bullnose Notched
- 6 2 3/4" Bullnose Smooth

② Flip Top Unit Cutout:

- S Single Centered (84"-120"[2134mm-3048mm] Widths), add **\$259.37** list
- D Two Left/Right (132"-240"[3353mm-6096mm] Widths), add **\$511.04** list
- N None

③ Border Option: Upcharge (list)

- N None
- O Border

2) Wood surface finish.

Executive Wood Tables

	Depth	Width	No. of Sections	Number	①	②	③	Wood Group B	D	Upcharge Border Option (O)	
Racetrack	1 1/2"(38mm) Edge										
	36"(914mm)	60"(1524mm)	1	TERT-3660-W	TN			\$ 3995.76	\$ 4465.05	\$1293.02	
		66"(1676mm)	1	TERT-3666-W	TN			4349.16	4862.55	1372.52	
		72"(1829mm)	1	TERT-3672-W	TN			4702.56	5260.05	1451.12	
		78"(1981mm)	1	TERT-3678-W	TN			5055.96	5657.55	1529.72	
		84"(2134mm)	1	TERT-3684-W	TN			5409.36	6055.05	1608.32	
	2 3/4"(70mm) Edge										
	36"(914mm)	60"(1524mm)	1	TERT-3660-W	KN			\$ 7035.54	\$ 7504.83	\$1293.92	
		66"(1676mm)	1	TERT-3666-W	KN			7657.98	8171.37	1372.52	
		72"(1829mm)	1	TERT-3672-W	KN			8280.42	8837.91	1451.12	
		78"(1981mm)	1	TERT-3678-W	KN			8902.86	9504.45	1529.72	
		84"(2134mm)	1	TERT-3684-W	KN			9525.30	10170.99	1608.32	
	1 1/2"(38mm) Edge										
	42"(1067mm)	78"(1981mm)	1	TERT-4278-W	TN			\$ 5605.36	\$ 6302.50	\$1608.32	
		84"(2134mm)	1	TERT-4284-W	T			5986.76	6735.35	1686.92	
		96"(2438mm)	1	TERT-4296-W	T			6749.56	7601.05	1844.12	
		108"(2743mm)	1	TERT-42A8-W	T			7512.36	8466.75	2001.32	
		120"(3048mm)	1	TERT-42C0-W	T			8275.16	9332.45	2158.52	
	2 3/4"(70mm) Edge										
	42"(1067mm)	78"(1981mm)	1	TERT-4278-W	KN			\$ 9721.30	\$10418.44	\$1608.32	
		84"(2134mm)	1	TERT-4284-W	K			10371.74	11120.33	1686.92	
	96"(2438mm)	1	TERT-4296-W	K			11672.62	12524.11	1844.12		
	108"(2743mm)	1	TERT-42A8-W	K			12973.50	13927.89	2001.32		
	120"(3048mm)	1	TERT-42C0-W	K			14274.38	15331.67	2158.52		
1 1/2"(38mm) Edge											
48"(1219mm)	84"(2134mm)	1	TERT-4884-W	T			\$ 6564.16	\$ 7415.65	\$1765.52		
	96"(2438mm)	1	TERT-4896-W	T			7382.96	8352.05	1922.72		
	108"(2743mm)	1	TERT-48A8-W	T			8201.76	9288.45	2079.92		
	120"(3048mm)	1	TERT-48C0-W	T			9020.56	10224.85	2237.12		
	132"(3353mm)	2	TERT-48D2-W	T			10573.25	11895.14	2568.14		
	144"(3658mm)	2	TERT-48E4-W	T			11392.05	12831.54	2725.34		
	156"(3962mm)	2	TERT-48F6-W	T			12210.85	13767.94	2882.54		
	168"(4267mm)	2	TERT-48G8-W	T			13029.65	14704.34	3039.74		
	180"(4572mm)	2	TERT-48J0-W	T			15663.80	17456.09	3293.50		
	192"(4877mm)	2	TERT-48K2-W	T			16598.48	18508.37	3450.70		
	204"(5182mm)	2	TERT-48L4-W	T			17533.16	19560.65	3607.90		
	216"(5486mm)	2	TERT-48M6-W	T			18467.84	20612.93	3765.10		
	228"(5791mm)	2	TERT-48N8-W	T			19402.52	21665.21	3922.30		
	240"(6096mm)	2	TERT-48Q0-W	T			20337.20	22717.49	4079.50		
2 3/4"(70mm) Edge											
48"(1219mm)	84"(2134mm)	1	TERT-4884-W	K			\$11218.18	\$12069.67	\$1765.52		
	96"(2438mm)	1	TERT-4896-W	K			12575.06	13544.15	1922.72		
	108"(2743mm)	1	TERT-48A8-W	K			13931.94	15018.63	2079.92		
	120"(3048mm)	1	TERT-48C0-W	K			15288.82	16493.11	2237.12		
	132"(3353mm)	2	TERT-48D2-W	K			17746.51	19068.40	2568.14		
	144"(3658mm)	2	TERT-48E4-W	K			19103.39	20542.88	2725.34		
	156"(3962mm)	2	TERT-48F6-W	K			20460.27	22017.36	2882.54		
	168"(4267mm)	2	TERT-48G8-W	K			21817.15	23491.84	3039.74		
	180"(4572mm)	2	TERT-48J0-W	K			25568.77	27361.06	3293.50		
	192"(4877mm)	2	TERT-48K2-W	K			27253.93	29163.82	3450.70		
	204"(5182mm)	2	TERT-48L4-W	K			28939.09	30966.58	3607.90		
	216"(5486mm)	2	TERT-48M6-W	K			30624.25	32769.34	3765.10		
	228"(5791mm)	2	TERT-48N8-W	K			32309.41	34572.10	3922.30		
	240"(6096mm)	2	TERT-48Q0-W	K			33994.57	36374.86	4079.50		

Executive Wood Tables

Depth	Width	No. of Sections	Number	①	②	③	Wood Group B	D	Upcharge Border Option (O)
Racetrack									
1 1/2"(38mm) Edge									
54"(1372mm)	108"(2743mm)	1	TERT-54A8-W	T			\$ 8891.16	\$10110.15	\$2158.52
	120"(3048mm)	1	TERT-54C0-W	T			9765.96	11117.25	2315.72
	132"(3353mm)	2	TERT-54D2-W	T			11683.63	13167.22	2646.74
	144"(3658mm)	2	TERT-54E4-W	T			12674.31	14290.20	2803.94
	156"(3962mm)	2	TERT-54F6-W	T			13664.99	15413.18	2961.14
	168"(4267mm)	2	TERT-54G8-W	T			14655.67	16536.16	3118.34
	180"(4572mm)	2	TERT-54J0-W	T			16689.20	18701.99	3372.10
	192"(4877mm)	2	TERT-54K2-W	T			17679.88	19824.97	3529.30
	204"(5182mm)	2	TERT-54L4-W	T			18670.56	20947.95	3686.50
	216"(5486mm)	2	TERT-54M6-W	T			19661.24	22070.93	3843.70
	228"(5791mm)	2	TERT-54N8-W	T			20651.92	23193.91	4000.90
	240"(6096mm)	2	TERT-54Q0-W	T			21642.60	24316.89	4158.10
2 3/4"(70mm) Edge									
54"(1372mm)	108"(2743mm)	1	TERT-54A8-W	K			\$14890.38	\$16109.37	\$2158.52
	120"(3048mm)	1	TERT-54C0-W	K			16303.26	17654.55	2315.72
	132"(3353mm)	2	TERT-54D2-W	K			19319.09	20802.68	2646.74
	144"(3658mm)	2	TERT-54E4-W	K			21079.61	22695.50	2803.94
	156"(3962mm)	2	TERT-54F6-W	K			22840.13	24588.32	2961.14
	168"(4267mm)	2	TERT-54G8-W	K			24600.65	26481.14	3118.34
	180"(4572mm)	2	TERT-54J0-W	K			27056.33	29069.12	3372.10
	192"(4877mm)	2	TERT-54K2-W	K			28913.41	31058.50	3529.30
	204"(5182mm)	2	TERT-54L4-W	K			30770.49	33047.88	3686.50
	216"(5486mm)	2	TERT-54M6-W	K			32627.57	35037.26	3843.70
	228"(5791mm)	2	TERT-54N8-W	K			34484.65	37026.64	4000.90
	240"(6096mm)	2	TERT-54Q0-W	K			36341.73	39016.02	4158.10
1 1/2"(38mm) Edge									
60"(1524mm)	108"(2743mm)	1	TERT-60A8-W	T			\$ 9580.56	\$10931.85	\$2237.12
	120"(3048mm)	1	TERT-60C0-W	T			10511.36	12009.65	2394.32
	132"(3353mm)	2	TERT-60D2-W	TN			12687.81	14333.10	2725.34
	144"(3658mm)	2	TERT-60E4-W	T			13734.49	15526.78	2882.54
	156"(3962mm)	2	TERT-60F6-W	T			14781.17	16720.46	3039.74
	168"(4267mm)	2	TERT-60G8-W	T			15827.85	17914.14	3196.94
	180"(4572mm)	2	TERT-60J0-W	T			17405.61	19638.90	3450.70
	192"(4877mm)	2	TERT-60K2-W	T			18452.29	20832.58	3607.90
	204"(5182mm)	2	TERT-60L4-W	T			19498.97	22026.26	3765.10
	216"(5486mm)	2	TERT-60M6-W	T			20545.65	23219.94	3922.30
	228"(5791mm)	2	TERT-60N8-W	T			21592.33	24413.62	4079.50
	240"(6096mm)	2	TERT-60Q0-W	T			22639.01	25607.30	4236.70
2 3/4"(70mm) Edge									
60"(1524mm)	108"(2743mm)	1	TERT-60A8-W	K			\$15848.82	\$17200.11	\$2237.12
	120"(3048mm)	1	TERT-60C0-W	K			17317.70	18815.99	2394.32
	132"(3353mm)	2	TERT-60D2-W	KN			20737.14	22382.43	2725.34
	144"(3658mm)	2	TERT-60E4-W	K			22553.66	24345.95	2882.54
	156"(3962mm)	2	TERT-60F6-W	K			24370.18	26309.47	3039.74
	168"(4267mm)	2	TERT-60G8-W	K			26186.70	28272.99	3196.94
	180"(4572mm)	2	TERT-60J0-W	K			28737.03	30970.32	3450.70
	192"(4877mm)	2	TERT-60K2-W	K			30785.29	33165.58	3607.90
	204"(5182mm)	2	TERT-60L4-W	K			32833.55	35360.84	3765.10
	216"(5486mm)	2	TERT-60M6-W	K			34881.81	37556.10	3922.30
	228"(5791mm)	2	TERT-60N8-W	K			36930.07	39751.36	4079.50
	240"(6096mm)	2	TERT-60Q0-W	K			38978.33	41946.62	4236.70

Executive Wood Tables

Rectangular Table Depths	Widths	Base Qty/Size	Number ①	Wood Group B	D
Base Kits — Racetrack Wood Tables					
Full Cylinder Base Kits					
36"-42"(914mm-1067mm)	60"-120"(1524mm-3048mm)	2-18"(457mm)	TEFC-1802-W █ 4	\$3406.94	\$4499.73
48"-54"(1219mm-1372mm)	84"-120"(2134mm-3048mm)	2-24"(610mm)	TEFC-2402-W █ 4	3628.89	4792.89
	132"-240"(3353mm-6096mm)	3-24"(610mm)	TEFC-2403-W █ 4	5442.06	7187.62
60"(1524mm)	108"-120"(2743mm-3048mm)	2-30"(762mm)	TEFC-3002-W █ 4	4026.40	5317.86
	132"-240"(3353mm-6096mm)	3-30"(762mm)	TEFC-3003-W █ 4	6038.27	7975.09
Full/Half Cylinder Base Kits					
48"-54"(1219mm-1372mm)	132"-240"(3353mm-6096mm)	3-24"(610mm)	TEFH-2403-W █ 4	\$5476.92	\$7233.66
60"(1524mm)	132"-240"(3353mm-6096mm)	3-30"(762mm)	TEFH-3003-W █ 4	6070.53	8017.69
Half Cylinder Base Kits					
36"-42"(914mm-1067mm)	60"-120"(1524mm-3048mm)	2-18"(457mm)	TEHC-1802-W █ 4	\$3501.36	\$4624.03
48"-54"(1219mm-1372mm)	84"-120"(2134mm-3048mm)	2-24"(610mm)	TEHC-2402-W █ 4	3653.02	4775.69
	132"-240"(3353mm-6096mm)	3-24"(610mm)	TEHC-2403-W █ 4	5442.06	7187.62
60"(1524mm)	108"-120"(2743mm-3048mm)	2-30"(762mm)	TEHC-3002-W █ 4	4078.22	5200.89
Wood X Base Kits					
36"-54"(914mm-1372mm)	60"-120"(1524mm-3048mm)	2-26"(660mm)	TEXB-2602-WN4	\$3379.67	\$4463.73
	132"-240"(3353mm-6096mm)	3-26"(660mm)	TEXB-2603-WN4	5068.83	6694.70
60"(1524mm)	108"-120"(2743mm-3048mm)	2-32"(813mm)	TEXB-3202-WN4	3550.30	4689.11
	132"-240"(3353mm-6096mm)	3-32"(813mm)	TEXB-3203-WN4	5325.45	7033.63
Wood Slab Base Kits					
	2-60"(1524mm)	TESL-3060-WN4		\$2468.69	\$3260.52
	2-66"(1676mm)	TESL-3066-WN4		2478.81	3273.87
	2-72"(1829mm)	TESL-3072-WN4		2488.93	3287.22
	2-78"(1981mm)	TESL-3078-WN4		2499.05	3300.57
	2-84"(2134mm)	TESL-3084-WN4		2509.17	3313.92
	2-96"(2438mm)	TESL-3096-WN4		2529.41	3340.62
	2-108"(2743mm)	TESL-30A8-WN4		2549.65	3367.32
	2-120"(3048mm)	TESL-30C0-WN4		2569.89	3394.02
	3-132"(3353mm)	TESL-30D2-WN4		4117.86	5438.68
	3-144"(3658mm)	TESL-30E4-WN4		4350.54	5746.04
	3-156"(3962mm)	TESL-30F6-WN4		4583.22	6053.40
	3-168"(4267mm)	TESL-30G8-WN4		4815.90	6360.76
	3-180"(4572mm)	TESL-30J0-WN4		5048.58	6668.12
	3-192"(4877mm)	TESL-30K2-WN4		5281.26	6975.48
	3-204"(5182mm)	TESL-30L4-WN4		5513.94	7282.84
	3-216"(5486mm)	TESL-30M6-WN4		5746.62	7590.20
	3-228"(5791mm)	TESL-30N8-WN4		5979.30	7897.56
	3-240"(6096mm)	TESL-30Q0-WN4		6211.98	8204.92

Base Kits — Racetrack Wood Tables

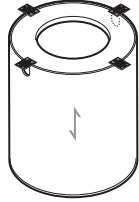

TEFC

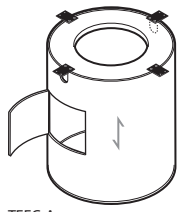

TEHC-A

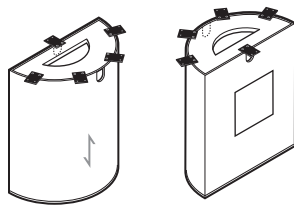

TEHB

TEHC-A

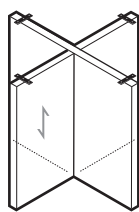

TEXB-W

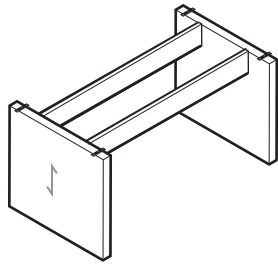

TESL

Note: ↙ = Wood Grain Direction

Features

- Each kit includes 28"(711mm) high base kit(s) with attachment hardware:
 - Full Cylinder Base: Wood veneer over wood base; available with optional Access Door for power access.
 - Full Cylinder and Half Cylinder Bases have cord access cutout.
 - Half Cylinder Base: Wood veneer over wood base.
 - Each Full Cylinder and Half Cylinder base includes weight for stability.
- Wood X Base: Two 26"(660mm) or 32"(813mm) deep, 1 1/4"(32mm) thick wood veneer slabs.
- Slab Base: 30"(762mm) deep, 2"(51mm) thick wood veneer with Keel sets:
 - One base set includes one Keel set.
 - Three base kit includes two Keel sets.
- Glide adjustment of 1"(25mm) on all bases.
- Cylinders ship assembled; other bases require field assembly.

To Order, Specify:

1) Product number, including:

X Base – Wood

① Access Hatch Option (Full Cylinder):

- A** Access Door, upcharges (list) per kit
Base Qty Two, add \$1022.08 list
Base Qty Three, add \$1533.12 list
- N** No Access Door

2) Wood surface finish.

X Base/Slab Base

- 1) Product number.
- 2) Wood surface finish.

Executive Wood Tables

Boat

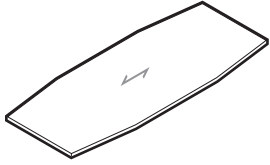

TEBO
(60"-120")

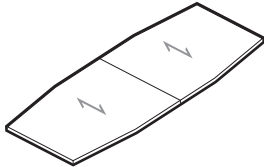

TEBO
(132"-240"
[3353mm-6096mm])

Note: ↗ = Wood Grain Direction

Features

- Includes one piece (60"-120"[1524mm-3048mm] wide) or two piece (132"-240"[3353mm-6096mm] wide) Boat shaped wood veneer top with solid wood edge:
 - 1 1/2"(38mm) Edge: Square (1), Bevel (2), Chamfer (3) or Radius (4).
 - 2 3/4"(70mm) Edge: Bullnose Notched (5) or Bullnose Smooth (6).
 - Boat top depths taper 6"(152mm) at ends; i.e., 36"(914mm) depth top is 30"(762mm) at each end.
- Border (O) option has black 1/8"(3mm) thick inlay.
- Base Kits are specified separately.
- Base kits include Full Cylinder, Half Cylinder, Full/Half Cylinder Wood X Base and Wood Slab Base.
- Flip Top Unit Cutout Options available for separately specified Flip Top Unit(s) on tops greater than 36"(914mm) deep:
 - One centered cutout (S) (84"-120"[2134mm-3048mm] wide tops).
 - Two left/right cutouts (D) (132"-240"[3353mm-6096mm] wide tops).
 - Cutouts are centered between bases.

Note: On site measurements should be taken to ensure there is adequate room in elevators and/or hallway conditions to accommodate the top sizes.

Cutout options: S - One 12-port Double-Sided Flip Top Unit
D - Two 12-port Double-Sided Flip Top Units

To Order, Specify:

1) Product number, including:

1 Edge Option:

- 1 1 1/2" Square
- 2 1 1/2" Bevel
- 3 1 1/2" Chamfer
- 4 1 1/2" Radius
- 5 2 3/4" Bullnose Notched
- 6 2 3/4" Bullnose Smooth

2 Flip Top Unit Cutout:

- S Single Centered (84"-120"[2134mm-3048mm] Widths), add **\$259.37** list
- D Two Left/Right (132"-240"[3353mm-6096mm] Widths), add **\$518.74** list
- N None

3 Border Option: Upcharge (list)

- N None
- O Border

2) Wood surface finish.

Executive Wood Tables

Boat	Depth	Width	No. of Sections	Number	① ② ③			Wood Group		Upcharge Border Option (O)
					B	D				
1 1/2" (38mm) Edge										
	36"/30"(914mm/762mm)	60"(1524mm)	1	TEBO-3660-W	TN			\$ 3813.56	\$ 4261.47	\$1234.95
		66"(1676mm)	1	TEBO-3666-W	TN			4150.88	4640.91	1310.07
		72"(1829mm)	1	TEBO-3672-W	TN			4488.20	5020.35	1385.19
		78"(1981mm)	1	TEBO-3678-W	TN			4825.52	5399.79	1460.31
		84"(2134mm)	1	TEBO-3684-W	TN			5162.84	5779.23	1535.43
2 3/4" (70mm) Edge										
	36"/30"(914mm/762mm)	60"(1524mm)	1	TEBO-3660-W	KN			\$ 6714.76	\$ 7162.67	\$1234.95
		66"(1676mm)	1	TEBO-3666-W	KN			7308.64	7798.67	1310.07
		72"(1829mm)	1	TEBO-3672-W	KN			7902.52	8434.67	1385.19
		78"(1981mm)	1	TEBO-3678-W	KN			8496.40	9070.67	1460.31
		84"(2134mm)	1	TEBO-3684-W	KN			9090.28	9706.67	1535.43
1 1/2" (38mm) Edge										
	42"/36"(1067mm/914mm)	78"(1981mm)	1	TEBO-4278-W	TN			\$ 5349.88	\$ 6015.41	\$1535.43
		84"(2134mm)	1	TEBO-4284-W	T			5713.92	6428.59	1610.55
		96"(2438mm)	1	TEBO-4296-W	T			6442.00	7254.95	1760.79
		108"(2743mm)	1	TEBO-42A8-W	T			7170.08	8081.31	1911.03
		120"(3048mm)	1	TEBO-42C0-W	T			7898.16	8907.67	2061.27
2 3/4" (70mm) Edge										
	42"/36"(1067mm/914mm)	78"(1981mm)	1	TEBO-4278-W	KN			\$ 9277.32	\$ 9942.85	\$1535.43
		84"(2134mm)	1	TEBO-4284-W	K			9897.92	10612.59	1610.55
		96"(2438mm)	1	TEBO-4296-W	K			11139.12	11952.07	1760.79
		108"(2743mm)	1	TEBO-42A8-W	K			12380.32	13291.55	1911.03
		120"(3048mm)	1	TEBO-42C0-W	K			13621.52	14631.03	2061.27
1 1/2" (38mm) Edge										
	48"/42"(1219mm/1067mm)	84"(2134mm)	1	TEBO-4884-W	T			\$ 6265.00	\$ 7077.95	\$1685.67
		96"(2438mm)	1	TEBO-4896-W	T			7046.52	7971.79	1835.91
		108"(2743mm)	1	TEBO-48A8-W	T			7828.04	8865.63	1986.15
		120"(3048mm)	1	TEBO-48C0-W	T			8609.56	9759.47	2136.39
		132"(3353mm)	2	TEBO-48D2-W	T			10091.50	11353.73	2452.53
		144"(3658mm)	2	TEBO-48E4-W	T			10873.02	12247.57	2602.77
		156"(3962mm)	2	TEBO-48F6-W	T			11654.54	13141.41	2753.01
		168"(4267mm)	2	TEBO-48G8-W	T			12436.06	14035.25	2903.25
		180"(4572mm)	2	TEBO-48J0-W	T			14950.19	16661.70	3145.63
		192"(4877mm)	2	TEBO-48K2-W	T			15842.33	17666.16	3295.87
		204"(5182mm)	2	TEBO-48L4-W	T			16734.47	18670.62	3446.11
		216"(5486mm)	2	TEBO-48M6-W	T			17626.61	19675.08	3596.35
		228"(5791mm)	2	TEBO-48N8-W	T			18518.75	20679.54	3746.59
		240"(6096mm)	2	TEBO-48Q0-W	T			19410.89	21684.00	3896.83
2 3/4" (70mm) Edge										
	48"/42"(1219mm/1067mm)	84"(2134mm)	1	TEBO-4884-W	K			\$10705.56	\$11518.51	\$1685.67
		96"(2438mm)	1	TEBO-4896-W	K			12000.20	12925.47	1835.91
		108"(2743mm)	1	TEBO-48A8-W	K			13294.84	14332.43	1986.15
		120"(3048mm)	1	TEBO-48C0-W	K			14589.48	15739.39	2136.39
		132"(3353mm)	2	TEBO-48D2-W	K			16934.76	18196.99	2452.53
		144"(3658mm)	2	TEBO-48E4-W	K			18229.40	19603.95	2602.77
		156"(3962mm)	2	TEBO-48F6-W	K			19524.04	21010.91	2753.01
		168"(4267mm)	2	TEBO-48G8-W	K			20818.68	22417.87	2903.25
		180"(4572mm)	2	TEBO-48J0-W	K			24398.86	26110.37	3145.63
		192"(4877mm)	2	TEBO-48K2-W	K			26006.84	27830.67	3295.87
		204"(5182mm)	2	TEBO-48L4-W	K			27614.82	29550.97	3446.11
		216"(5486mm)	2	TEBO-48M6-W	K			29222.80	31271.27	3596.35
		228"(5791mm)	2	TEBO-48N8-W	K			30830.78	32991.57	3746.59
		240"(6096mm)	2	TEBO-48Q0-W	K			32438.76	34711.87	3896.83

Executive Wood Tables

Boat	Depth	Width	No. of Sections	Number	① ② ③			Wood Group		Upcharge Border Option (O)
					B	D				
1 1/2"(38mm) Edge										
	54"/48"(1372mm/1219mm)	108"(2743mm)	1	TEBO-54A8-W	T			\$ 8486.00	\$ 9649.95	\$2061.27
		120"(3048mm)	1	TEBO-54C0-W	T			9320.96	10611.27	2211.51
		132"(3353mm)	2	TEBO-54D2-W	T			11151.28	12567.95	2527.65
		144"(3658mm)	2	TEBO-54E4-W	T			12096.86	13639.89	2677.89
		156"(3962mm)	2	TEBO-54F6-W	T			13042.44	14711.83	2828.13
		168"(4267mm)	2	TEBO-54G8-W	T			13988.02	15783.77	2978.37
		180"(4572mm)	2	TEBO-54J0-W	T			15928.79	17850.90	3220.75
		192"(4877mm)	2	TEBO-54K2-W	T			16874.37	18922.84	3370.99
		204"(5182mm)	2	TEBO-54L4-W	T			17819.95	19994.78	3521.23
		216"(5486mm)	2	TEBO-54M6-W	T			18765.53	21066.72	3671.47
		228"(5791mm)	2	TEBO-54N8-W	T			19711.11	22138.66	3821.71
		240"(6096mm)	2	TEBO-54Q0-W	T			20656.69	23210.60	3971.95
2 3/4"(70mm) Edge										
	54"/48"(1372mm/1219mm)	108"(2743mm)	1	TEBO-54A8-W	K			\$14209.36	\$15373.31	\$2061.27
		120"(3048mm)	1	TEBO-54C0-W	K			15557.44	16847.75	2211.51
		132"(3353mm)	2	TEBO-54D2-W	K			18088.18	19504.85	2527.65
		144"(3658mm)	2	TEBO-54E4-W	K			19768.06	21311.09	2677.89
		156"(3962mm)	2	TEBO-54F6-W	K			21447.94	23117.33	2828.13
		168"(4267mm)	2	TEBO-54G8-W	K			23127.82	24923.57	2978.37
		180"(4572mm)	2	TEBO-54J0-W	K			25818.34	27740.45	3220.75
		192"(4877mm)	2	TEBO-54K2-W	K			27590.36	29638.83	3370.99
		204"(5182mm)	2	TEBO-54L4-W	K			29362.38	31537.21	3521.23
		216"(5486mm)	2	TEBO-54M6-W	K			31134.40	33435.59	3671.47
		228"(5791mm)	2	TEBO-54N8-W	K			32906.42	35333.97	3821.71
		240"(6096mm)	2	TEBO-54Q0-W	K			34678.44	37232.35	3971.95
1 1/2"(38mm) Edge										
	60"/54"(1525mm/1372mm)	108"(2743mm)	1	TEBO-60A8-W	T			\$ 9143.96	\$10434.27	\$2136.39
		120"(3048mm)	1	TEBO-60C0-W	T			10032.36	11463.07	2286.63
		132"(3353mm)	2	TEBO-60D2-W	TN			12109.66	13680.77	2602.77
		144"(3658mm)	2	TEBO-60E4-W	T			13108.68	14820.19	2753.01
		156"(3962mm)	2	TEBO-60F6-W	T			14107.70	15959.61	2903.25
		168"(4267mm)	2	TEBO-60G8-W	T			15106.72	17099.03	3053.49
		180"(4572mm)	2	TEBO-60J0-W	T			16612.46	18745.17	3295.87
		192"(4877mm)	2	TEBO-60K2-W	T			17611.48	19884.59	3446.11
		204"(5182mm)	2	TEBO-60L4-W	T			18610.50	21024.01	3596.35
		216"(5486mm)	2	TEBO-60M6-W	T			19609.52	22163.43	3746.59
		228"(5791mm)	2	TEBO-60N8-W	T			20608.54	23302.85	3896.83
		240"(6096mm)	2	TEBO-60Q0-W	T			21607.56	24442.27	4047.07
2 3/4"(70mm) Edge										
	60"/54"(1525mm/1372mm)	108"(2743mm)	1	TEBO-60A8-W	K			\$15123.88	\$16414.19	\$2136.39
		120"(3048mm)	1	TEBO-60C0-W	K			16525.40	17956.11	2286.63
		132"(3353mm)	2	TEBO-60D2-W	KN			19788.58	21359.69	2602.77
		144"(3658mm)	2	TEBO-60E4-W	K			21521.90	23233.41	2753.01
		156"(3962mm)	2	TEBO-60F6-W	K			23255.22	25107.13	2903.25
		168"(4267mm)	2	TEBO-60G8-W	K			24988.54	26980.85	3053.49
		180"(4572mm)	2	TEBO-60J0-W	K			27422.15	29554.86	3295.87
		192"(4877mm)	2	TEBO-60K2-W	K			29376.63	31649.74	3446.11
		204"(5182mm)	2	TEBO-60L4-W	K			31331.11	33744.62	3596.35
		216"(5486mm)	2	TEBO-60M6-W	K			33285.59	35839.50	3746.59
		228"(5791mm)	2	TEBO-60N8-W	K			35240.07	37934.38	3896.83
		240"(6096mm)	2	TEBO-60Q0-W	K			37194.55	40029.26	4047.07

Executive Wood Tables

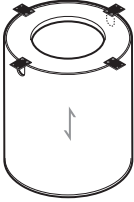
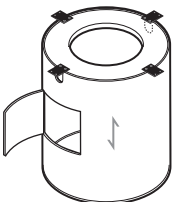
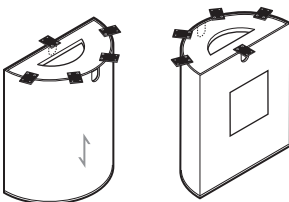
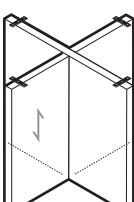
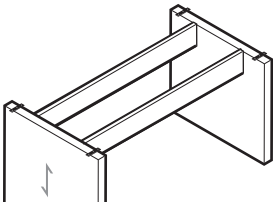
	Depths	Widths	Base Qty/Size	Number ①	Wood Group B	D
Base Kits — Boat Wood Tables						
Full Cylinder Base Kits						
	36"-42"(914mm-1067mm)	60"-120"(1524mm-3048mm)	2"-18"(457mm)	TEFC-1802-W 4	\$3406.94	\$4499.73
	48"-54"(1219mm-1372mm)	84"-120"(2134mm-3048mm)	2"-24"(610mm)	TEFC-2402-W 4	3628.89	4792.89
		132"-240"(3353mm-6096mm)	3"-24"(610mm)	TEFC-2403-W 4	5442.06	7187.62
	60"(1524mm)	108"-120"(2743mm-3048mm)	2"-30"(762mm)	TEFC-3002-W 4	4026.40	5317.86
132"-240"(3353mm-6096mm)		3"-30"(762mm)	TEFC-3003-W 4	6038.27	7975.09	
Full/Half Cylinder Base Kits						
	48"-54"(1219mm-1372mm)	132"-240"(3353mm-6096mm)	3"-24"(610mm)	TEFH-2403-W 4	\$5476.92	\$7233.66
	60"(1524mm)	132"-240"	3"-30"(762mm)	TEFH-3003-W 4	6070.53	8017.69
Half Cylinder Base Kits						
	36"-42"(914mm-1067mm)	60"-120"(1524mm-3048mm)	2"-18"(457mm)	TEHC-1802-W 4	\$3501.36	\$4624.03
	48"-54"(1219mm-1372mm)	84"-120"(2134mm-3048mm)	2"-24"(610mm)	TEHC-2402-W 4	3653.02	4775.69
		108"-120"(2743mm-3048mm)	2"-30"(762mm)	TEHC-3002-W 4	4078.22	5200.89
Wood X Base Kits						
	36"-54"(914mm-1372mm)	60"-120"(1524mm-3048mm)	2"-26"(660mm)	TEXB-2602-WN4	\$3379.67	\$4463.73
		132"-240"(3353mm-6096mm)	3"-26"(660mm)	TEXB-2603-WN4	5068.83	6694.70
	60"(1524mm)	108"-120"(2743mm-3048mm)	2"-32"(813mm)	TEXB-3202-WN4	3550.30	4689.11
132"-240"(3353mm-6096mm)		3"-32"(813mm)	TEXB-3203-WN4	5325.45	7033.63	
Wood Slab Base Kits						
			2"-60"(1524mm)	TESL-3060-WN4	\$2468.69	\$3260.52
			2"-66"(1676mm)	TESL-3066-WN4	2478.81	3273.87
			2"-72"(1829mm)	TESL-3072-WN4	2488.93	3287.22
			2"-78"(1981mm)	TESL-3078-WN4	2499.05	3300.57
			2"-84"(2134mm)	TESL-3084-WN4	2509.17	3313.92
			2"-96"(2438mm)	TESL-3096-WN4	2529.41	3340.62
			2"-108"(2743mm)	TESL-30A8-WN4	2549.65	3367.32
			2"-120"(3048mm)	TESL-30C0-WN4	2569.89	3394.02
			3"-132"(3353mm)	TESL-30D2-WN4	4117.86	5438.68
			3"-144"(3658mm)	TESL-30E4-WN4	4350.54	5746.04
			3"-156"(3962mm)	TESL-30F6-WN4	4583.22	6053.40
			3"-168"(4267mm)	TESL-30G8-WN4	4815.90	6360.76
			3"-180"(4572mm)	TESL-30J0-WN4	5048.58	6668.12
			3"-192"(4877mm)	TESL-30K2-WN4	5281.26	6975.48
			3"-204"(5182mm)	TESL-30L4-WN4	5513.94	7282.84
			3"-216"(5486mm)	TESL-30M6-WN4	5746.62	7590.20
			3"-228"(5791mm)	TESL-30N8-WN4	5979.30	7897.56
		3"-240"(6096mm)	TESL-30Q0-WN4	6211.98	8204.92	

TEFC

TEFC-A

TEHC

TEHC-A

TEXB-W

TESL

Note: ↗ = Wood Grain Direction

Features

- Each kit includes 28"(711 mm) high base kit(s) with attachment hardware:
- Full Cylinder Base: Wood veneer over wood base; available with optional Access Door for power access.
- Full Cylinder and Half Cylinder Bases have cord access cutout.
 - Half Cylinder Base: Wood veneer over wood base.
 - Each Full Cylinder and Half Cylinder base includes weight for stability.
 - Wood X Base: Two 26"(660mm) or 32"(813mm) deep, 1 1/4"(32mm) thick wood veneer slabs.
- Slab Base: 30"(762mm) deep, 2"(51mm) thick wood veneer with Keel sets:
 - One base set includes one Keel set.
 - Three base kit includes two Keel sets.
- Glide adjustment of 1"(25mm) on all bases.
- Cylinders ship assembled; other bases require field assembly.

To Order, Specify:

Full/Half Cylinder Base

- 1) Product number, including:

① Access Hatch Option (Full Cylinder):

- A** Access Door, upcharges (list) per kit
Base Qty Two, add \$1022.08 list
Base Qty Three, add \$1533.12 list
- N** No Access Door

- 2) Wood surface finish.

X Base/Slab Base

- 1) Product number.
- 2) Wood surface finish.

Executive Wood Tables

Wedge

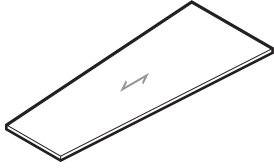

TEWE
(84" - 120")

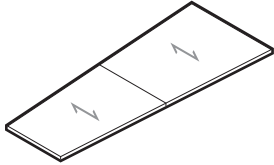

TEWE
(132"-240"
[3353mm-6096mm])

Note: ↯ = Wood Grain Direction

Features

- Includes one piece (84"-120"[2134mm-3048mm] wide) or two piece (132"-240"[3353mm-6096mm] wide) Wedge shaped wood veneer top with solid wood edge:
 - 1 1/2" Edge: Square (1), Bevel (2), Chamfer (3) or Radius (4).
 - 2 3/4" Edge: Bullnose Notched (5) or Bullnose Smooth (6).
 - Wedge top depths taper 12"(305mm) from wider end; i.e., 48"(1219mm) deep to 36"(914mm) deep.
- Border (O) option has black 1/8"(3mm) thick inlay.
- Base Kits are specified separately.
- Base kits include Full Cylinder, Half Cylinder, Full/Half Cylinder, Wood X Base and Wood Slab Base.
- Flip Top Unit Cutout Options available for separately specified Flip Top Unit(s):
 - One centered cutout (S) (84-120"[2134mm-3048mm] wide tops).
 - Two left/right cutouts (D) (132-240"[3353mm-6096mm] wide tops).
 - Cutouts are centered between bases.

Note: On site measurements should be taken to ensure there is adequate room in elevators and/or hallway conditions to accommodate the top sizes.

Cutout options: S - One 12-port Double-Sided Flip Top Unit
D - Two 12-port Double-Sided Flip Top Units

To Order, Specify:

1) Product number, including:

1 Edge Option:

- 1 1 1/2" Square
- 2 1 1/2" Bevel
- 3 1 1/2" Chamfer
- 4 1 1/2" Radius
- 5 2 3/4" Bullnose Notched
- 6 2 3/4" Bullnose Smooth

2 Flip Top Unit Cutout:

- S Single Centered (84"-120"[2134mm-3048mm] Widths), add **\$259.37** list
- D Two Left/Right (132"-240"[3353mm-6096mm] Widths), add **\$518.74** list
- N None

3 Border Option: Upcharge (list)

- N None
- O Border

2) Wood surface finish.

Executive Wood Tables

Wedge	Depth	Width	No. of Sections	Number	① ② ③			Wood Group		Upcharge Border Option (O)
					B	D				
1 1/2"(38mm) Edge										
	48"/36"(1219mm/914mm)	84"(2134mm)	1	TEWE-4884-W	T			\$ 4450.91	\$ 5026.42	\$1197.44
		96"(2438mm)	1	TEWE-4896-W	T			5006.43	5661.14	1304.24
		108"(2743mm)	1	TEWE-48A8-W	T			5561.95	6295.86	1411.04
		120"(3048mm)	1	TEWE-48C0-W	T			6117.47	6930.58	1517.84
		132"(3353mm)	2	TEWE-48D2-W	T			7175.65	8067.96	1742.45
		144"(3658mm)	2	TEWE-48E4-W	T			7731.17	8702.68	1849.25
		156"(3962mm)	2	TEWE-48F6-W	T			8286.69	9337.40	1956.05
		168"(4267mm)	2	TEWE-48G8-W	T			8842.21	9972.12	2062.85
		180"(4572mm)	2	TEWE-48J0-W	T			10622.99	11832.10	2235.10
		192"(4877mm)	2	TEWE-48K2-W	T			11257.03	12545.34	2341.90
		204"(5182mm)	2	TEWE-48L4-W	T			11891.07	13258.58	2448.70
		216"(5486mm)	2	TEWE-48M6-W	T			12525.11	13971.82	2555.50
		228"(5791mm)	2	TEWE-48N8-W	T			13159.15	14685.06	2662.30
		240"(6096mm)	2	TEWE-48Q0-W	T			13793.19	15398.30	2769.10
2 3/4"(70mm) Edge										
	48"/36"(1219mm/914mm)	84"(2134mm)	1	TEWE-4884-W	K			\$ 7603.56	\$ 8179.07	\$1197.44
		96"(2438mm)	1	TEWE-4896-W	K			8523.16	9177.87	1304.24
		108"(2743mm)	1	TEWE-48A8-W	K			9442.76	10176.67	1411.04
		120"(3048mm)	1	TEWE-48C0-W	K			10362.36	11175.47	1517.84
		132"(3353mm)	2	TEWE-48D2-W	K			12035.94	12928.25	1742.45
		144"(3658mm)	2	TEWE-48E4-W	K			12955.54	13927.05	1849.25
		156"(3962mm)	2	TEWE-48F6-W	K			13875.14	14925.85	1956.05
		168"(4267mm)	2	TEWE-48G8-W	K			14794.74	15924.65	2062.85
		180"(4572mm)	2	TEWE-48J0-W	K			17329.69	18538.80	2235.10
		192"(4877mm)	2	TEWE-48K2-W	K			18471.81	19760.12	2341.90
		204"(5182mm)	2	TEWE-48L4-W	K			19613.93	20981.44	2448.70
		216"(5486mm)	2	TEWE-48M6-W	K			20756.05	22202.76	2555.50
		228"(5791mm)	2	TEWE-48N8-W	K			21898.17	23424.08	2662.30
		240"(6096mm)	2	TEWE-48Q0-W	K			23040.29	24645.40	2769.10
1 1/2"(48mm) Edge										
	54"/42"(1372mm/1067mm)	108"(2743mm)	1	TEWE-54A8-W	T			\$ 6029.71	\$ 6852.72	\$1464.44
		120"(3048mm)	1	TEWE-54C0-W	T			6623.23	7535.34	1571.24
		132"(3353mm)	2	TEWE-54D2-W	T			7923.60	8924.81	1795.85
		144"(3658mm)	2	TEWE-54E4-W	T			8595.64	9685.95	1902.65
		156"(3962mm)	2	TEWE-54F6-W	T			9267.68	10447.09	2009.45
		168"(4267mm)	2	TEWE-54G8-W	T			9939.72	11208.23	2116.25
		180"(4572mm)	2	TEWE-54J0-W	T			11318.75	12676.36	2288.50
		192"(4877mm)	2	TEWE-54K2-W	T			11990.79	13437.50	2395.30
		204"(5182mm)	2	TEWE-54L4-W	T			12662.83	14198.64	2502.10
		216"(5486mm)	2	TEWE-54M6-W	T			13334.87	14959.78	2608.90
		228"(5791mm)	2	TEWE-54N8-W	T			14006.91	15720.92	2715.70
		240"(6096mm)	2	TEWE-54Q0-W	T			14678.95	16482.06	2822.50

Executive Wood Tables

Wedge	Depth	Width	No. of Sections	Number	① ② ③			Wood Group		Upcharge Border Option (O)
					B	D				
2 3/4"(70mm) Edge										
	54"/42"(1372mm/1067mm)	108"(2743mm)	1	TEWE-54A8-W	K			\$10092.56	\$10915.57	\$1464.44
		120"(3048mm)	1	TEWE-54C0-W	K			11050.16	11962.27	1571.24
		132"(3353mm)	2	TEWE-54D2-W	K			13094.24	14095.45	1795.85
		144"(3658mm)	2	TEWE-54E4-W	K			14287.46	15377.77	1902.65
		156"(3962mm)	2	TEWE-54F6-W	K			15480.68	16660.09	2009.45
		168"(4267mm)	2	TEWE-54G8-W	K			16673.90	17942.41	2116.25
		180"(4572mm)	2	TEWE-54J0-W	K			18338.39	19696.00	2288.50
		192"(4877mm)	2	TEWE-54K2-W	K			19597.05	21043.76	2395.30
		204"(5182mm)	2	TEWE-54L4-W	K			20855.71	22391.52	2502.10
		216"(5486mm)	2	TEWE-54M6-W	K			22114.37	23739.28	2608.90
		228"(5791mm)	2	TEWE-54N8-W	K			23373.03	25087.04	2715.70
		240"(6096mm)	2	TEWE-54Q0-W	K			24631.69	26434.80	2822.50
1 1/2"(38mm) Edge										
	60"/42"(1524mm/1067mm)	108"(2743mm)	1	TEWE-60A8-W	T			\$ 6497.47	\$ 7409.58	\$1517.84
		120"(3048mm)	1	TEWE-60C0-W	T			7128.99	8140.10	1624.64
		132"(3353mm)	2	TEWE-60D2-W	T			8604.81	9714.92	1849.25
		144"(3658mm)	2	TEWE-60E4-W	T			9314.85	10523.96	1956.05
		156"(3962mm)	2	TEWE-60F6-W	T			10024.89	11333.00	2062.85
		168"(4267mm)	2	TEWE-60G8-W	T			10734.93	12142.04	2169.65
		180"(4572mm)	2	TEWE-60J0-W	T			11805.06	13311.17	2341.90
		192"(4877mm)	2	TEWE-60K2-W	T			12515.10	14120.21	2448.70
		204"(5182mm)	2	TEWE-60L4-W	T			13225.14	14929.25	2555.50
		216"(5486mm)	2	TEWE-60M6-W	T			13935.18	15738.29	2662.30
		228"(5791mm)	2	TEWE-60N8-W	T			14645.22	16547.33	2769.10
		240"(6096mm)	2	TEWE-60Q0-W	T			15355.26	17356.37	2875.90
2 3/4"(70mm) Edge										
	60"/42"(1524mm/1067mm)	108"(2743mm)	1	TEWE-60A8-W	K			\$10742.36	\$11654.47	\$1517.84
		120"(3048mm)	1	TEWE-60C0-W	K			11737.96	12749.07	1624.64
		132"(3353mm)	2	TEWE-60D2-W	K			14055.67	15165.78	1849.25
		144"(3658mm)	2	TEWE-60E4-W	K			15286.89	16496.00	1956.05
		156"(3962mm)	2	TEWE-60F6-W	K			16518.11	17826.22	2062.85
		168"(4267mm)	2	TEWE-60G8-W	K			17749.33	19156.44	2169.65
		180"(4572mm)	2	TEWE-60J0-W	K			19477.98	20984.09	2341.90
		192"(4877mm)	2	TEWE-60K2-W	K			20866.26	22471.37	2448.70
		204"(5182mm)	2	TEWE-60L4-W	K			22254.54	23958.65	2555.50
		216"(5486mm)	2	TEWE-60M6-W	K			23642.82	25445.93	2662.30
		228"(5791mm)	2	TEWE-60N8-W	K			25031.10	26933.21	2769.10
		240"(6096mm)	2	TEWE-60Q0-W	K			26419.38	28420.49	2875.90

Executive Wood Tables

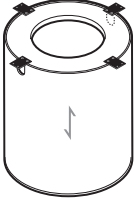
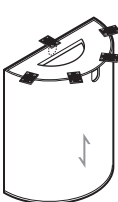
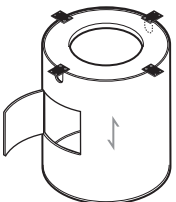
	Depths	Widths	Base Qty/Size	Number ①	Wood Group B	D
Base Kits — Wedge Wood Tables						
Full Cylinder Base Kits						
	48"-60"(1219mm-1524mm)	84"-120"(2134mm-3048mm)	2-24"(610mm)	TEFC-2402-W 4	\$3628.89	\$4792.89
		132"-240"(3353mm-6096mm)	3-24"(610mm)	TEFC-2403-W 4	5442.06	7187.62
Full/Half Cylinder Base Kits						
	48"-60"(1219mm-1524mm)	132"-240"(3353mm-6096mm)	3-24"(610mm)	TEFH-2403-W 4	\$5476.92	\$7233.66
Half Cylinder Base Kits						
	48"-60"(1219mm-1524mm)	84"-120"(2134mm-3048mm)	2-24"(610mm)	TEHC-2402-W 4	\$3653.02	\$4775.69
Wood X Base Kits						
	48"-60"(1219mm-1524mm)	84"-120"(2134mm-3048mm)	2-32"(813mm)	TEXB-3202-WN4	\$3550.30	\$4689.11
		132"-240"(3353mm-6096mm)	3-32"(813mm)	TEXB-3203-WN4	5325.45	7033.63
Wood Slab Base Kits						
			2-84"(2134mm)	TESL-3084-WN4	\$2509.17	\$3313.92
			2-96"(2438mm)	TESL-3096-WN4	2529.41	3340.62
			2-108"(2743mm)	TESL-30A8-WN4	2549.65	3367.32
			2-120"(3048mm)	TESL-30C0-WN4	2569.89	3394.02
			3-132"(3353mm)	TESL-30D2-WN4	4117.86	5438.68
			3-144"(3658mm)	TESL-30E4-WN4	4350.54	5746.04
			3-156"(3962mm)	TESL-30F6-WN4	4583.22	6053.40
			3-168"(4267mm)	TESL-30G8-WN4	4815.90	6360.76
			3-180"(4572mm)	TESL-30J0-WN4	5048.58	6668.12
			3-192"(4877mm)	TESL-30K2-WN4	5281.26	6975.48
			3-204"(5182mm)	TESL-30L4-WN4	5513.94	7282.84
			3-216"(5486mm)	TESL-30M6-WN4	5746.62	7590.20
			3-228"(5791mm)	TESL-30N8-WN4	5979.30	7897.56
			3-240"(6096mm)	TESL-30Q0-WN4	6211.98	8204.92

TEFC

TEFC-A

TEHC

TEHC-A

TEXB-W

TESL

Note: ↴ = Wood Grain Direction

Features

- Each kit includes 28"(711mm) high base kit(s) with attachment hardware:
 - Full Cylinder Base: Wood veneer over wood base; available with optional Access Door for power access.
 - Full Cylinder and Half Cylinder Bases have cord access cutout.
 - Half Cylinder Base: Wood veneer over wood base.
 - Each Full Cylinder and Half Cylinder base includes weight for stability.
- Wood X Base: Two 26"(660mm) or 32"(813mm) deep, 1 1/4"(32mm) thick wood veneer slabs.
- X Base: 30"(762mm) deep, 1 1/4"(32mm) thick wood veneer slabs.
- Slab Base: 30"(762mm) deep, 2"(51mm) thick wood veneer with Keel sets:
 - One base set includes one Keel set.
 - Three base kit includes two Keel sets.
- Glide adjustment of 1"(25mm) on all bases.
- Cylinders ship assembled; other bases require field assembly.

To Order, Specify:

- 1) Product number, including:
 - X Base – Wood**
 - 1) Access Hatch Option (Full Cylinder):
 - A** Access Door, upcharges (list) per kit
 - Base Qty Two, add \$1022.08 list
 - Base Qty Three, add \$1533.12 list
 - N** No Access Door
 - 2) Wood surface finish.
- X Base/Slab Base**
 - 1) Product number.
 - 2) Wood surface finish.

Executive Wood Tables – A5 — Specifications

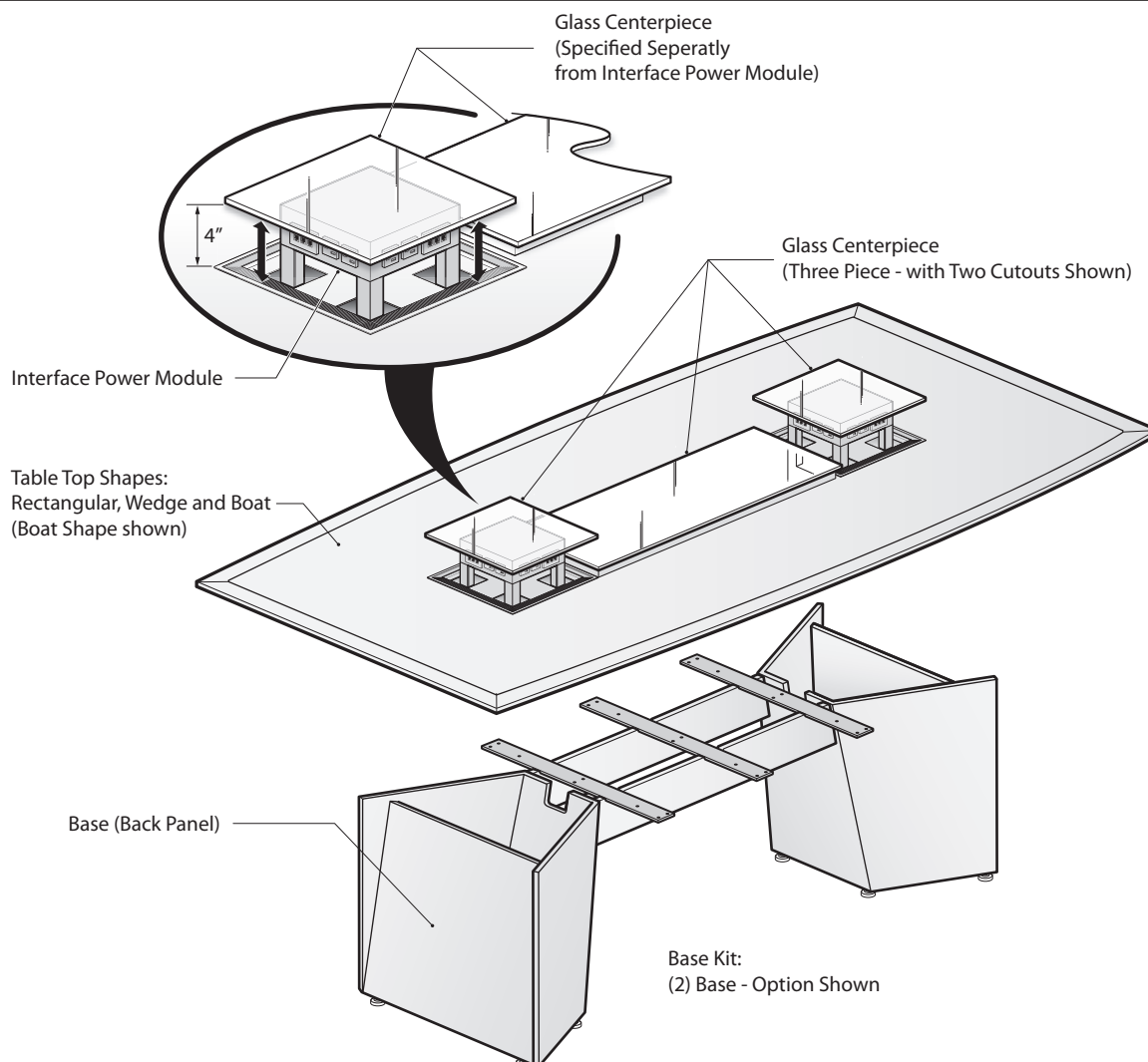

Construction Features

- One piece tops (120"[3048mm] widths) are constructed with 1 1/2"(38mm) fiber board substrate.
- Two piece tops (132"-240"[3353mm-6096mm] widths) are constructed with 1 1/2"(38mm) fiber board substrate and are secured together with tight joint fasteners. The tops are field joint built to go together.
- Knife edge is 1 1/2"(38mm) thick solid wood with a rake of 20.82° tapering 3"(76mm) from the edge. The top of the edge is made of quarter cut veneer of the species specified for the top, creating a 3"(76mm) border which is separated by the field with a 1/8"(3mm) thick black inlay.
- Base height is 28"(711mm).
- Finished table height is 29 1/2"(749mm).
- Table top dimensions are actual; however, the tables are natural wood and dimensional variance is +/- 1/4"(6mm) per top.
- Boat Table Top Depth / Taper:
 - The 54"(1372mm) depth Boat Table Top tapers to a 48"(1219mm) depth at each end.
 - The 60"(1524mm) depth Boat Table Top tapers to a 54"(1372mm) depth at each end.
- Wedge Table Top Depth / Taper:
 - The 54"(1372mm) depth Wedge Table Top tapers to a 42"(1067mm) depth on one end.
 - The 60" depth Wedge Table Top tapers to a 48" depth on one end.

Wood / Finish Features

- Top field veneer is plain-sliced and book-and-center matched; border is quarter-cut veneer.
- Veneer is AWI (Architectural Woodworking Institute) Grade AA tops with conversion varnish finish. Refer to finish matrix.
- Table is designed for non-dining applications; it is highly recommended that a protective accessory be used on table tops when possible.

Executive Wood Tables – A5 — Specifications

Cutout Locations

- Cutouts available for separately specified Interface Power Module.
 - 2 Cutout option available on all sizes.
 - 3 Cutout option available on tops 192”(4877mm) wide or greater.
- Knife edge is 1 1/2”(38mm) thick solid wood with a rake of 20.82° tapering 3”(76mm) from the edge.
- Base, Interface Power Module and Glass Centerpiece must be specified separately.

Top View with (3) Cutouts

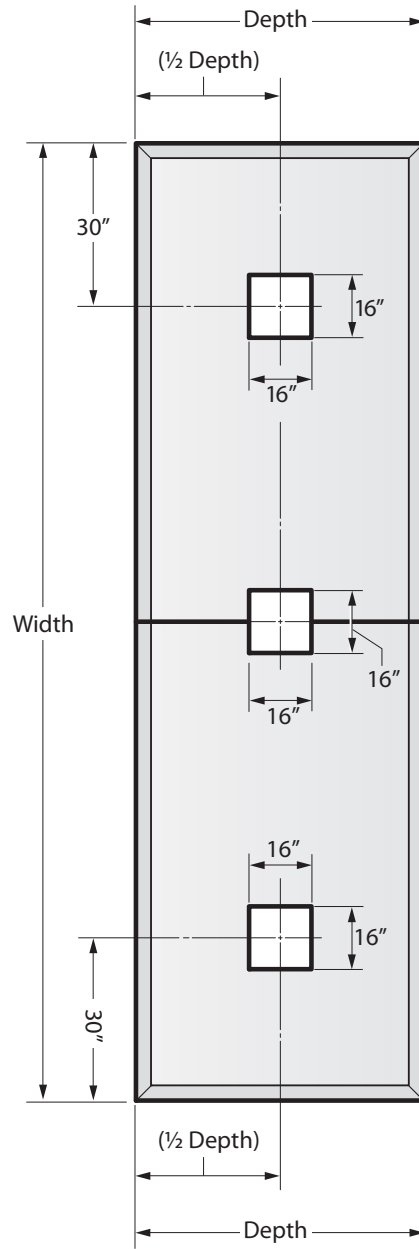

Top View with (2) Cutouts

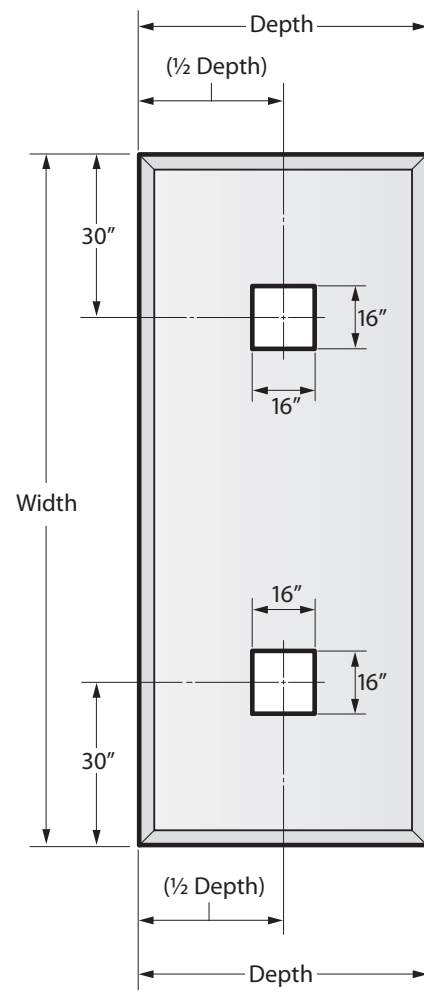

Section/Side View — Cutout Location/Edge Detail

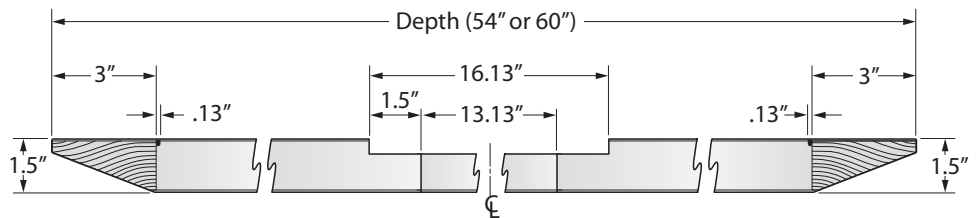

Executive Wood Tables – A5 — Specifications

Wood Grain Direction

- Two-piece tops are field joint built and secured with tight joint features.
- Base, Interface Power Module and Glass Centerpiece must be specified separately.

Top View with (1) Piece Top

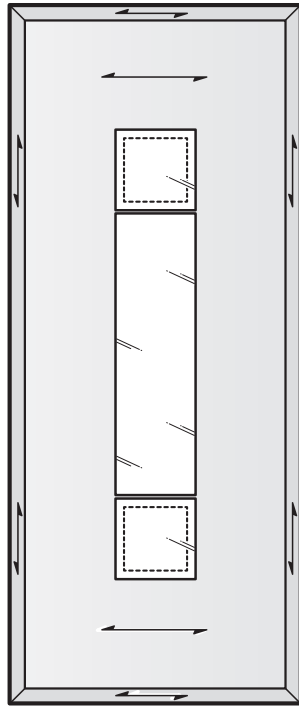

Top View with (2) Piece Top

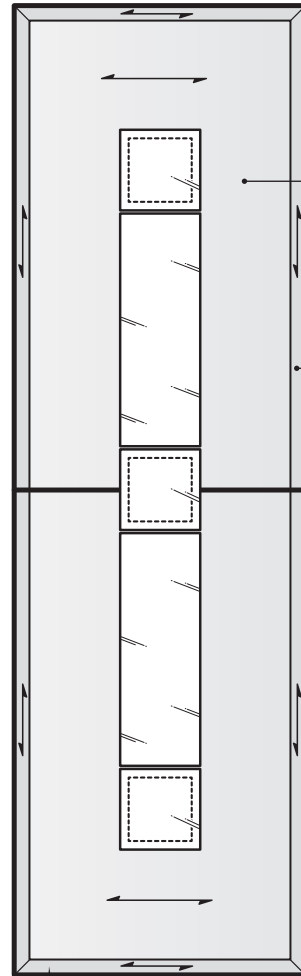

Arrow describes
Wood Grain Direction



**Knife Edge /
Black Inlay Detail**

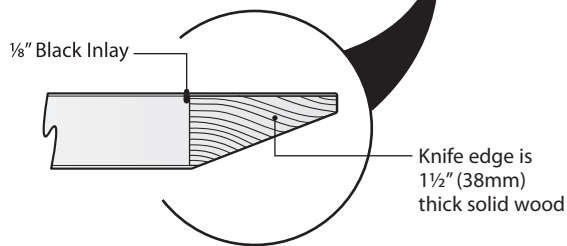

Executive Wood Tables – A5

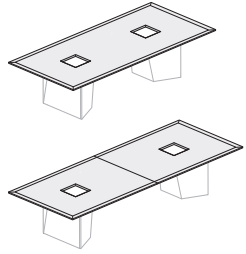
	Depth	Width	Pieces	Number	①	Wood Group	
						A	D
Rectangular Table Top 	54"(1372mm)	120"(3048mm)	1	TERA-54C0-WAT	O	\$18413.68	\$26406.63
		132"(3353mm)	2	TERA-54D2-WAT	O	21311.89	30483.30
		144"(3658mm)	2	TERA-54E4-WAT	O	23241.43	33591.30
		156"(3962mm)	2	TERA-54F6-WAT	O	25170.97	36699.30
		168"(4267mm)	2	TERA-54G8-WAT	O	27100.51	39807.30
		180"(4572mm)	2	TERA-54J0-WAT	O	30957.03	44842.28
		192"(4877mm)	2	TERA-54K2-WAT	O	33688.43	48752.14
		204"(5182mm)	2	TERA-54L4-WAT	O	36419.83	52662.00
		216"(5486mm)	2	TERA-54M6-WAT	O	39151.23	56571.86
		228"(5791mm)	2	TERA-54N8-WAT	O	41882.63	60481.72
		240"(6096mm)	2	TERA-54Q0-WAT	O	44614.03	64391.58
		60"(1524mm)	120"(3048mm)	1	TERA-60C0-WAT	O	\$19469.64
	132"(3353mm)		2	TERA-60D2-WAT	O	22641.48	32466.47
	144"(3658mm)		2	TERA-60E4-WAT	O	24609.02	35622.37
	156"(3962mm)		2	TERA-60F6-WAT	O	26576.56	38778.27
	168"(4267mm)		2	TERA-60G8-WAT	O	28544.10	41934.17
	180"(4572mm)		2	TERA-60J0-WAT	O	32202.99	46781.42
	192"(4877mm)		2	TERA-60K2-WAT	O	34972.39	50739.18
	204"(5182mm)		2	TERA-60L4-WAT	O	37741.79	54696.94
	216"(5486mm)		2	TERA-60M6-WAT	O	40511.19	58654.70
	228"(5791mm)		2	TERA-60N8-WAT	O	43280.59	62612.46
	240"(6096mm)		2	TERA-60Q0-WAT	O	46049.99	66570.22

Features

- Includes top only.
- Constructed of 1 1/2"(38mm) thick fiber board substrate with AWI (Architectural Woodworking Institute) Grade AA veneer with knife edge and mitered corners.
- Finished with conversion varnish.
- Two-piece tops are field joint built and secured with tight joint fasteners.
- Knife edge is 1 1/2"(38mm) thick solid wood with a rake of 20.82° tapering 3"(76mm) from the edge.
- Black inlay is 1/8"(3mm) thick and set 3"(76mm) from the edges.
- Cutouts available for separately specified Electric Lift Interface Module.
 - 2 Cutout option available on all sizes.
 - 3 Cutout option available on tops 192"(4877mm) wide or greater.
- Base, Electric Lift Interface Module and Glass Centerpiece must be specified separately.

Note: On site measurements should be taken to ensure there is adequate room in elevators and/or hallway conditions to accommodate the top sizes.

To Order, Specify:

1) Product number, including:

① Cutout Option:

- 2** Two (left/right) cutouts for Electric Lift Interface Module, add \$518.74 list
- 3** Three (left/center/right) cutouts for Electric Lift Interface Module, add \$778.10 list (192"(4877mm) width or greater)
- N** No cutout

2) Wood finish.

Executive Wood Tables – A5

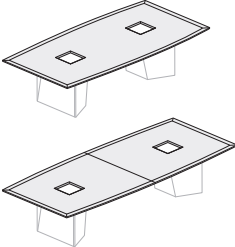
	Depth	Width	Pieces	Number	①	Wood Group	
						A	D
Boat Table Top  TEBO	54"(1372mm)/48"(1219mm)	120"(3048mm)	1	TEBO-54C0-WAT	■ O	\$24927.84	\$34715.47
		132"(3353mm)	2	TEBO-54D2-WAT	■ O	28883.29	40104.56
	144"(3658mm)	2	TEBO-54E4-WAT	■ O	31586.35	44241.26	
	156"(3962mm)	2	TEBO-54F6-WAT	■ O	34289.41	48377.96	
	168"(4267mm)	2	TEBO-54G8-WAT	■ O	36992.47	52514.66	
	180"(4572mm)	2	TEBO-54J0-WAT	■ O	41413.57	58369.40	
	192"(4877mm)	2	TEBO-54K2-WAT	■ O	44918.49	63307.96	
	204"(5182mm)	2	TEBO-54L4-WAT	■ O	48423.41	68246.52	
	216"(5486mm)	2	TEBO-54M6-WAT	■ O	51928.33	73185.08	
	228"(5791mm)	2	TEBO-54N8-WAT	■ O	55433.25	78123.64	
	240"(6096mm)	2	TEBO-54Q0-WAT	■ O	58938.17	83062.20	
	60"(1524mm)/54"(1372mm)	120"(3048mm)	1	TEBO-60C0-WAT	■ O	\$26455.48	\$37037.15
		132"(3353mm)	2	TEBO-60D2-WAT	■ O	29142.26	41171.61
		144"(3658mm)	2	TEBO-60E4-WAT	■ O	31663.14	45140.17
		156"(3962mm)	2	TEBO-60F6-WAT	■ O	34184.02	49108.73
		168"(4267mm)	2	TEBO-60G8-WAT	■ O	36704.90	53077.29
		180"(4572mm)	2	TEBO-60J0-WAT	■ O	43208.41	61028.48
		192"(4877mm)	2	TEBO-60K2-WAT	■ O	46766.77	66034.52
		204"(5182mm)	2	TEBO-60L4-WAT	■ O	50325.13	71040.56
		216"(5486mm)	2	TEBO-60M6-WAT	■ O	53883.49	76046.60
228"(5791mm)		2	TEBO-60N8-WAT	■ O	57441.85	81052.64	
240"(6096mm)		2	TEBO-60Q0-WAT	■ O	61000.21	86058.68	

Features

- Includes top only.
- Constructed of 1 1/2"(38mm) thick fiber board substrate with AWI (Architectural Woodworking Institute) Grade AA veneer with knife edge and mitered corners.
- Depth tapers in 6"(152mm) at ends.
- Finished with conversion varnish.
- Two-piece tops are field joint built and secured with tight joint fasteners.
- Knife edge is 1 1/2"(38mm) thick solid wood with a rake of 20.82° tapering 3"(76mm) from the edge.
- Black inlay is 1/8"(3mm) thick and set 3"(76mm) from the edges.
- Cutouts available for separately specified Electric Lift Interface Module.
 - 2 Cutout option available on all sizes.
 - 3 Cutout option available on tops 192"(4877mm) wide or greater.
- Base, Electric Lift Interface Module and Glass Centerpiece must be specified separately.

Note: On site measurements should be taken to ensure there is adequate room in elevators and/or hallway conditions to accommodate the top sizes.

To Order, Specify:

1) Product number, including:

① Cutout Option:

- 2** Two (left/right) cutouts for Electric Lift Interface Module, add \$518.74 list
- 3** Three (left/center/right) cutouts for Electric Lift Interface Module, add \$778.10 list (192"(4877mm) width or greater)
- N** No cutout

2) Wood finish.

Executive Wood Tables – A5

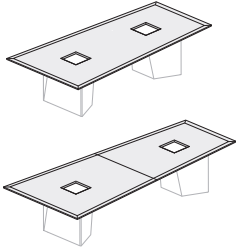
	Depth	Width	Pieces	Number	①	Wood Group		
						A	D	
Wedge Table Top  TEWE	54"(1372mm)/42"(1067mm)	120"(3048mm)	1	TEWE-54C0-WAT	█ O	\$18413.68	\$26406.63	
		132"(3353mm)	2	TEWE-54D2-WAT	█ O	21311.89	30483.30	
		144"(3658mm)	2	TEWE-54E4-WAT	█ O	23241.43	33591.30	
		156"(3962mm)	2	TEWE-54F6-WAT	█ O	25170.97	36699.30	
		168"(4267mm)	2	TEWE-54G8-WAT	█ O	27100.51	39807.30	
		180"(4572mm)	2	TEWE-54J0-WAT	█ O	30957.03	44842.28	
		192"(4877mm)	2	TEWE-54K2-WAT	█ O	33688.43	48752.14	
		204"(5182mm)	2	TEWE-54L4-WAT	█ O	36419.83	52662.00	
		216"(5486mm)	2	TEWE-54M6-WAT	█ O	39151.23	56571.86	
		228"(5791mm)	2	TEWE-54N8-WAT	█ O	41882.63	60481.72	
		240"(6096mm)	2	TEWE-54Q0-WAT	█ O	44614.03	64391.58	
		60"(1524mm)/48"(1219mm)	120"(3048mm)	1	TEWE-60C0-WAT	█ O	\$19469.64	\$28106.27
			132"(3353mm)	2	TEWE-60D2-WAT	█ O	22641.48	32466.47
			144"(3658mm)	2	TEWE-60E4-WAT	█ O	24609.02	35622.37
			156"(3962mm)	2	TEWE-60F6-WAT	█ O	26576.56	38778.27
			168"(4267mm)	2	TEWE-60G8-WAT	█ O	28544.10	41934.17
			180"(4572mm)	2	TEWE-60J0-WAT	█ O	32202.99	46781.42
			192"(4877mm)	2	TEWE-60K2-WAT	█ O	34972.39	50739.18
			204"(5182mm)	2	TEWE-60L4-WAT	█ O	37741.79	54696.94
			216"(5486mm)	2	TEWE-60M6-WAT	█ O	40511.19	58654.70
		228"(5791mm)	2	TEWE-60N8-WAT	█ O	43280.59	62612.46	
		240"(6096mm)	2	TEWE-60Q0-WAT	█ O	46049.99	66570.22	

Features

- Includes top only.
- Constructed of 1 1/2"(38mm) thick fiber board substrate with AWI (Architectural Woodworking Institute) Grade AA veneer with knife edge and mitered corners.
- Depth tapers in 12"(305mm) at smaller end.
- Finished with conversion varnish.
- Two-piece tops are field joint built and secured with tight joint fasteners.
- Knife edge is 1 1/2"(38mm) thick solid wood with a rake of 20.82° tapering 3"(76mm) from the edge.
- Black inlay is 1/8"(3mm) thick and set 3"(76mm) from the edges.
- Cutouts available for separately specified Electric Lift Interface Module.
 - 2 Cutout option available on all sizes.
 - 3 Cutout option available on tops 192"(4877mm) wide or greater.
- Base, Electric Lift Interface Module and Glass Centerpiece must be specified separately.

Note: On site measurements should be taken to ensure there is adequate room in elevators and/or hallway conditions to accommodate the top sizes.

To Order, Specify:

1) Product number, including:

① Cutout Option:

- 2** Two (left/right) cutouts for Electric Lift Interface Module, add \$518.74 list
- 3** Three (left/center/right) cutouts for Electric Lift Interface Module, add \$778.10 list (192"(4877mm) width or greater)
- N** No cutout

2) Wood finish.

Executive Wood Tables – A5

	Height	Table Width	Base Width	Bases	Number	Wood Group	
						A	D
 <p>TEAS</p>	27.5"(700mm)	120"(3048mm)	84"(2134mm)	2	TEA5-32C0-WN4	\$11833.79	\$15629.50
		132"(3353mm)	96"(2438mm)	2	TEA5-32D2-WN4	12122.15	16010.34
		144"(3658mm)	108"(2743mm)	2	TEA5-32E4-WN4	12410.51	16391.18
		156"(3962mm)	120"(3048mm)	3	TEA5-32F6-WN4	12698.87	16772.02
		168"(4267mm)	132"(3353mm)	3	TEA5-32G8-WN4	12987.23	17152.86
		180"(4572mm)	144"(3658mm)	3	TEA5-32J0-WN4	13275.59	17533.70
		192"(4877mm)	156"(3962mm)	3	TEA5-32K2-WN4	13563.95	17914.54
		204"(5182mm)	168"(4267mm)	3	TEA5-32L4-WN4	13852.31	18295.38
		216"(5486mm)	180"(4572mm)	3	TEA5-32M6-WN4	14140.67	18676.22
		228"(5791mm)	192"(4877mm)	3	TEA5-32N8-WN4	14429.03	19057.06
		240"(6096mm)	204"(5182mm)	3	TEA5-32Q0-WN4	14717.39	19437.90

Features

- Includes stretchers and two or three pre-assembled bases depending on top size.
- Bases are constructed with AWI (Architectural Woodworking Institute) Grade AA veneer.
- Bases are angled with a maximum width of 32.6"(829mm) and taper to 18"(457mm) and are joined by 6"(152mm) aprons.
- Bases are inset 18"(457mm) from each end.
- Back panel of each base is removable.
- Inner panel features 3" x 4"(77mm x 102mm) port for wire access.
- Glides are black with 1"(25mm) height adjustment.
- Assemble stretchers to bases.

To Order, Specify:

- 1) Product Number.
- 2) Wood Finish.

Executive Wood Tables – A5

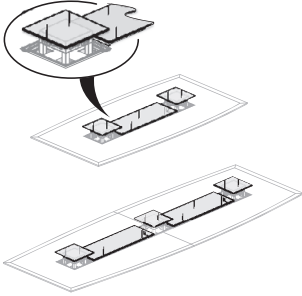
	Width	Cutouts	Number	Price
 <p>TEGL</p>	Glass Centerpiece			
	No Cutouts			
	120"(3048mm)	0	TEGL-16C0-1	\$3501.45
	132"(3353mm)	0	TEGL-16D2-1	3516.99
	144"(3658mm)	0	TEGL-16E4-1	3532.53
	156"(3962mm)	0	TEGL-16F6-1	3548.07
	168"(4267mm)	0	TEGL-16G8-1	3563.61
	180"(4572mm)	0	TEGL-16J0-1	3579.15
	192"(4877mm)	0	TEGL-16K2-1	3594.69
	204"(5182mm)	0	TEGL-16L4-1	3610.23
	216"(5486mm)	0	TEGL-16M6-1	3625.77
	228"(5791mm)	0	TEGL-16N8-1	3641.31
	240"(6096mm)	0	TEGL-16Q0-1	3656.85
	Two Cutouts			
	120"(3048mm)	2	TEGL-16C0-3	\$3501.45
	132"(3353mm)	2	TEGL-16D2-3	3516.99
	144"(3658mm)	2	TEGL-16E4-3	3532.53
	156"(3962mm)	2	TEGL-16F6-3	3548.07
	168"(4267mm)	2	TEGL-16G8-3	3563.61
	180"(4572mm)	2	TEGL-16J0-3	3579.15
	192"(4877mm)	2	TEGL-16K2-3	3594.69
	204"(5182mm)	2	TEGL-16L4-3	3610.23
	216"(5486mm)	2	TEGL-16M6-3	3625.77
	228"(5791mm)	2	TEGL-16N8-3	3641.31
	240"(6096mm)	2	TEGL-16Q0-3	3656.85
	Three Cutouts			
	192"(4877mm)	3	TEGL-16K2-5	\$3594.69
	204"(5182mm)	3	TEGL-16L4-5	3610.23
	216"(5486mm)	3	TEGL-16M6-5	3625.77
	228"(5791mm)	3	TEGL-16N8-5	3641.31
	240"(6096mm)	3	TEGL-16Q0-5	3656.85



Features

- Includes set of back-painted, tempered low-iron glass, 16"(406mm) wide and 3/8"(10mm) thick.
- Edges are polished and have 1/16"(4mm) bevel.
- Set includes (1) piece of glass when no cutouts are specified, (3) glass pieces when (2) cutouts are specified or (5) glass pieces when (3) cutouts are specified: one over each Electric Lift Interface Module and between cutouts.
- Glass centerpiece between Electric Lift Interface Module units are raised 1/2"(13mm) over the top with 10"(254mm) wide black spacer.

To Order, Specify:

- 1) Product Number.
- 2) Glass back-paint color. 2G-SLW

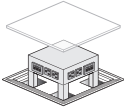
Executive Wood Tables – A5

	Description	Depth	Width	Number	Price
 EUIM 	Electric Lift Interface Module	11.76"(298.7mm)	18.5"(469.9mm)	EUIM-0000-A	\$5446.71
	Features <ul style="list-style-type: none"> Power/data module with electric lift control. Includes: <ul style="list-style-type: none"> –(4) 15 Amp duplex receptacles (one on each side) NEMA 5-15R configuration. –(4) cutouts for separately specified telecom plates (one on each side). –15 Amp circuit breaker –12' long cord with plug (NEMA 5-15P configuration). –Mounting trim with brush –Wired switchbox mechanism mountable to the table top Steel construction. Lift range 4"(102mm). Mounted to provide 1/2"(13mm) space for cables to remain plugged in. Glass centerpiece specified separately. 		To Order, Specify: <ol style="list-style-type: none"> Product number. (No finish specification required.) 		
Specification Tips <ul style="list-style-type: none"> For A5 tables only. Field cut not recommended. For use with 120 volt 60 hertz power source only. Electrical application requires prior approval by authority having jurisdiction. 					

Telecom Plates for Interface	Description	Number	Price
	(1) RJ45, (1) RJ11	EUTP-14BB	\$166.02
	(2) RJ45	EUTP-44BB	214.00
	(3) RJ45	EUTP-444B	311.27
	(4) RJ45	EUTP-4444	408.54
	(3) Cable Pass-Through Ports	EUTP-CCCB	97.28
	(2) RJ45, (1) VGA	EUTP-44VB	304.79
	(1) RJ45, (1) VGA, (1) 3.5mm Audio	EUTP-4VSB	337.21
	(1) HDMI	EUTP-HBBB	233.44
	(1) HDMI, (1) VGA, (1) 3.5mm Audio	EUTP-HVSB	453.92
	BLANK	EUTP-BBBB	19.46
	Feature <ul style="list-style-type: none"> Telecom plate for A5 Electric Lift Interface Module. Includes data and/or a/v connections as specified. 		To Order, Specify: <ol style="list-style-type: none"> Product number. (No finish specification required.)
	Specification Tip <ul style="list-style-type: none"> For A5 Electric Lift Interface Module only. 		

Executive Accessories

Height	Depth	Width	Number	①	Wood Group	Fabric Grade						
						A	B	C	D	E	F	G
48"(1219mm)	5 3/8"(137mm)	48"(1219mm)	TEPB-4848-WKS		B	\$6120.46	\$6148.24	\$6165.42	\$6193.21	\$6213.05	\$6304.31	\$6341.36
			TEPB-4848-WKS		D	6699.82	6727.60	6744.78	6772.57	6792.41	6883.67	6920.72

Presentation Board

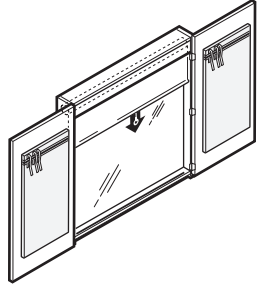

TEPB

Features

- Includes wood presentation board with hinged doors, flip chart clips, and tackboards on inside of doors and wall mount hardware.
- Fabric covered tackboards are attached in place on each door.
- Erasable porcelain writing surface on inside back panel (markers, eraser and flip charts are field supplied).
- Available with or without optional projection screen.

Specification Tip

- Must be properly anchored to a structural wall.

To Order, Specify:

- 1) Product number, including:

① Projection Screen Option:

- N No Projection Screen
- P Projection Screen, add **\$349.20** list

- 2) Wood finish color.
- 3) Tackboard fabric surface/color.

Hoop

This page intentionally blank

Hoop

	Height	Depth	Width	Number ①	Price
Hoop Table	40"(1016mm)	18"(457mm)	60"(1524mm)	T7MB-1860-7	\$2997.47

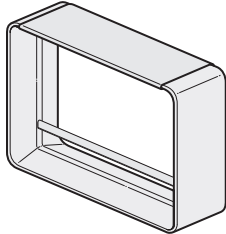

T7MB-1860-7

Features

- Includes one-piece rotationally molded frame with clear anodized foot rail and one cover with zipper.
- Weight: 55 lbs.

Specification Tip

- Intended for use as a meeting place for small group collaboration and social environments. Not intended to support heavy loads or equipment.

To Order, Specify:

- 1) Product number, including:

① Cover Option:

- F** Frost
- M** Misty
- S** Shadow

- 2) Surface color:
Fog – TR-7
Smooth Plaster – TR-PLS

This page intentionally blank

Immerse

This page intentionally blank

Immerse — Ledge Table

Rectangle – Painted Legs



THLD

Features

- Includes one ledge top, painted understructure and foot rail, four painted metal legs, adjustable glides and hardware.
- Laminate or wood veneer 1/2" thick top with waterfall edge.
- Ledge top wood has a hardboard laminated core.
- Glides have 1/2" (13mm) height adjustment and are standard in black.
- Depth and width shown in nominal dimensions.
- Ships unassembled.

Specification Tip

- Power is not available.

To Order, Specify:

- 1) Product number, including:

① Surface Type:

L Laminate

W Wood

- 2) Laminate or wood finish color.
- 3) Understructure and Foot Rail trim color.
Grade B, add **\$43.26** list.
- 4) Trim color. Grade B, add **\$43.26** list.

Height	Depth	Width	Number ①	Laminate Grade A	Grade B	Wood Group A	Group B
36"(914mm)	22"(559mm)	57"(1448mm)	THLD-2257- ■ WSNBG7P	\$2771.43	\$2987.14	\$2988.78	\$3189.68

Immerse — Ledge Table

Rectangle – Wood Legs



THLD

Features

- Includes one ledge top, painted understructure and foot rail, four solid wood legs, adjustable glides and hardware.
- Laminate or wood veneer 1/2" thick top with waterfall edge.
- Ledge top wood has a hardboard laminated core.
- Glides have 1/2"(13mm) height adjustment and are standard in black.
- Depth and width shown in nominal dimensions.
- Ships unassembled.

Specification Tip

- Power is not available.

To Order, Specify:

1) Product number, including:

① Surface Type:

- L Laminate
- W Wood

2) Laminate or wood finish color.

3) Understructure and Foot Rail trim color.
Grade B, add **\$43.26** list.

4) Wood leg finish.

M7-W43 Ink on Ash - no upcharge

M5-W35 Clear on White Oak, add **\$147.09** list

M6-W35 Clear on Walnut, add **\$444.57** list

Height	Depth	Width	Number ①	Laminate Grade A	Grade B	Wood Group A	Group B
36"(914mm)	22"(559mm)	57"(1448mm)	THLD-2257- <input type="checkbox"/> WSNBG7W	\$4122.82	\$4338.53	\$4340.17	\$4541.07

This page intentionally blank

Immerse — Overlap Table

Rectangle/Rectangle – Painted Legs

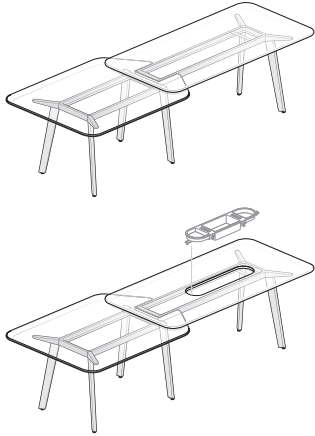

THRR

Features

- Includes two tops, painted understructure, six painted metal legs, adjustable glides and hardware.
- Tops: Lower top available in laminate, solid surface and wood veneer with knife edge. Lower top not available painted. Upper top available painted, laminate, solid surface or wood veneer with knife edge.
 - Painted 1 1/8”(29mm) thick
 - Laminate and wood veneer 1 3/16”(30mm) thick
 - Solid surface 1”(25mm) thick
- Solid surface is standard in Cameo White.
- Glides have 1/2”(13mm) height adjustment and are standard in black.
- Depth and width shown in nominal dimensions.
- Ships unassembled.

Specification Tips

- Power only available in the upper top.
- Separately specified power available. Use Oblong Planter (EHPO-____).
- When cutout option (-U) is selected, the cutout is on the upper top only.
- Overlap of top and bottom surfaces is 18 1/2”(470mm).
- Seating capacity of 11 based upon 27”(686mm) per chair.
- Tops share one understructure and are not designed to be separated.

Lower Top Dimensions

Height	Depth	Width
29”(737mm)	60”(1524mm)	78”(1981mm)
37.5”(953mm)	60”(1524mm)	78”(1981mm)

Upper Top Dimensions

Height	Depth	Width
30.5”(775mm)	48”(1219mm)	96”(2438mm)
39”(991mm)	48”(1219mm)	96”(2438mm)

To Order, Specify:

- 1) Product number, including:

1 Cutout Option:

- N** No Cutout
- U** Cutout - Upper Top, add **\$133.04** list

- 2) Lower surface finish/color.
- 3) Edge trim color (laminate only).
- 4) Upper surface finish/color.
- 5) Edge trim color (laminate only).
- 6) Understructure trim color. Grade B, add **\$43.26** list.
- 7) Trim color. Grade B, add **\$43.26** list.

Immerse — Overlap Table

Rectangle/Rectangle – Painted Legs

Overall Width	Number	①	Upper Top Laminate Grade A	Grade B	Paint Grade A	Grade B	Wood Group A	Group B	Solid Surface
Laminate Grade A Lower Top – 29”(737mm) Height									
156”(3962mm)	THRR-60F6-MFS	EGBP	N/A	N/A	\$ 8985.08	\$ 9007.79	N/A	N/A	N/A
	THRR-60F6-LFS	EGBP	\$ 7065.08	\$ 7314.12	N/A	N/A	N/A	N/A	N/A
	THRR-60F6-JFS	EGBP	N/A	N/A	N/A	N/A	N/A	N/A	\$20487.16
	THRR-60F6-QFS	EGBP	N/A	N/A	N/A	N/A	\$ 9681.40	\$ 9681.40	N/A
Laminate Grade A Lower Top – 37.5”(953mm) Height									
156”(3962mm)	THRR-60F6-MFS	EGCP	N/A	N/A	\$ 9150.59	\$ 9173.30	N/A	N/A	N/A
	THRR-60F6-LSS	EGCP	\$ 7230.59	\$ 7479.63	N/A	N/A	N/A	N/A	N/A
	THRR-60F6-JFS	EGCP	N/A	N/A	N/A	N/A	N/A	N/A	\$20652.67
	THRR-60F6-QFS	EGCP	N/A	N/A	N/A	N/A	\$ 9846.91	\$ 9846.91	N/A
Laminate Grade B Lower Top – 29”(737mm) Height									
156”(3962mm)	THRR-60F6-MFS	EGBP	N/A	N/A	\$ 9236.92	\$ 9259.63	N/A	N/A	N/A
	THRR-60F6-LFS	EGBP	\$ 7316.92	\$ 7565.96	N/A	N/A	N/A	N/A	N/A
	THRR-60F6-JFS	EGBP	N/A	N/A	N/A	N/A	N/A	N/A	\$20739.00
	THRR-60F6-QFS	EGBP	N/A	N/A	N/A	N/A	\$ 9933.24	\$ 9933.24	N/A
Laminate Grade B Lower Top – 37.5”(953mm) Height									
156”(3962mm)	THRR-60F6-MFS	EGCP	N/A	N/A	\$ 9402.43	\$ 9425.14	N/A	N/A	N/A
	THRR-60F6-LSS	EGCP	\$ 7482.43	\$ 7731.47	N/A	N/A	N/A	N/A	N/A
	THRR-60F6-JFS	EGCP	N/A	N/A	N/A	N/A	N/A	N/A	\$20904.51
	THRR-60F6-QFS	EGCP	N/A	N/A	N/A	N/A	\$10098.75	\$10098.75	N/A
Solid Surface Lower Top – 29”(737mm) Height									
156”(3962mm)	THRR-60F6-FUS	EGBP	N/A	N/A	\$22616.88	\$22639.59	N/A	N/A	N/A
	THRR-60F6-KFS	EGBP	\$20696.88	\$20945.92	N/A	N/A	N/A	N/A	N/A
	THRR-60F6-SSS	EGBP	N/A	N/A	N/A	N/A	N/A	N/A	\$34118.96
	THRR-60F6-EUS	EGBP	N/A	N/A	N/A	N/A	\$22578.48	\$23313.20	N/A
Solid Surface Lower Top – 37.5”(953mm) Height									
156”(3962mm)	THRR-60F6-FUS	EGCP	N/A	N/A	\$22782.39	\$22805.10	N/A	N/A	N/A
	THRR-60F6-KFS	EGCP	\$20862.39	\$21111.43	N/A	N/A	N/A	N/A	N/A
	THRR-60F6-SSS	EGCP	N/A	N/A	N/A	N/A	N/A	N/A	\$34284.47
	THRR-60F6-EUS	EGCP	N/A	N/A	N/A	N/A	\$22743.99	\$23478.71	N/A
Wood Group A Lower Top – 29”(737mm) Height									
156”(3962mm)	THRR-60F6-GUS	EGBP	N/A	N/A	\$10896.08	\$10918.79	N/A	N/A	N/A
	THRR-60F6-RFS	EGBP	\$ 8976.08	\$ 9225.12	N/A	N/A	N/A	N/A	N/A
	THRR-60F6-DUS	EGBP	N/A	N/A	N/A	N/A	N/A	N/A	\$22398.16
	THRR-60F6-WUS	EGBP	N/A	N/A	N/A	N/A	\$10857.68	\$11592.40	N/A
Wood Group A Lower Top – 37.5”(953mm) Height									
156”(3962mm)	THRR-60F6-GUS	EGCP	N/A	N/A	\$11061.59	\$11084.30	N/A	N/A	N/A
	THRR-60F6-RFS	EGCP	\$ 9141.59	\$ 9390.63	N/A	N/A	N/A	N/A	N/A
	THRR-60F6-DUS	EGCP	N/A	N/A	N/A	N/A	N/A	N/A	\$22563.67
	THRR-60F6-WUS	EGCP	N/A	N/A	N/A	N/A	\$11023.19	\$11757.91	N/A
Wood Group B Lower Top – 29”(737mm) Height									
156”(3962mm)	THRR-60F6-GUS	EGBP	N/A	N/A	\$11642.28	\$11664.99	N/A	N/A	N/A
	THRR-60F6-RFS	EGBP	\$ 9722.28	\$ 9971.32	N/A	N/A	N/A	N/A	N/A
	THRR-60F6-DUS	EGBP	N/A	N/A	N/A	N/A	N/A	N/A	\$23144.36
	THRR-60F6-WUS	EGBP	N/A	N/A	N/A	N/A	\$11603.88	\$12338.60	N/A
Wood Group B Lower Top – 37.5”(953mm) Height									
156”(3962mm)	THRR-60F6-GUS	EGCP	N/A	N/A	\$11807.79	\$11830.50	N/A	N/A	N/A
	THRR-60F6-RFS	EGCP	\$ 9887.79	\$10136.83	N/A	N/A	N/A	N/A	N/A
	THRR-60F6-DUS	EGCP	N/A	N/A	N/A	N/A	N/A	N/A	\$23309.87
	THRR-60F6-WUS	EGCP	N/A	N/A	N/A	N/A	\$11769.39	\$12504.11	N/A

Immerse — Overlap Table

Rectangle/Round – Painted Legs

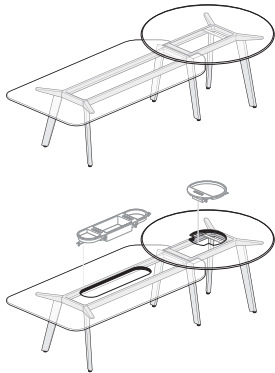

THRD

Features

- Includes lower racetrack top, upper round top, painted understructure, six painted metal legs, adjustable glides and hardware.
- Tops: Rectangle lower top available painted, laminate, solid surface and wood veneer with knife edge. Round upper top available in laminate, solid surface or wood veneer with knife edge. Round upper top not available painted.
 - Painted 1 1/8”(29mm) thick
 - Laminate and wood veneer 1 3/16”(30mm) thick
 - Solid surface 1”(25mm) thick
- Solid surface is standard in Cameo White.
- Glides have 1/2”(13mm) height adjustment and are standard in black.
- Depth and width shown in nominal dimensions.
- Ships unassembled.

Specification Tips

- Separately specified power available. Use Oblong Planter (EHPO-____) for the rectangle top and Round Planter (EHPR-____) for the round top.
- When cutout option (-L) is selected, the cutout is on the lower top, option (-P) the cutout is on the lower and upper top and option (-U) the cutout is on the upper top only.
- Overlap of top and bottom surfaces is 15 3/4”(400mm).
- Seating capacity of 8 based upon 27”(686mm) per chair.
- Tops share one understructure and are not designed to be separated.

Lower Top Dimensions

Height	Depth	Width
29”(737mm)	48”(1219mm)	96”(2438mm)

Upper Top Dimensions

Height	Diameter
30.5”(775mm)	60”(1524mm)

To Order, Specify:

1) Product number, including:

1 Cutout Option:

- N** No Cutout
- L** Cutout - Lower Top, add **\$133.04** list
- P** Cutout - Lower and Upper Top, add **\$266.08** list
- U** Cutout - Upper Top, add **\$133.04** list

- 2) Lower surface finish/color.
- 3) Edge trim color (laminate only).
- 4) Upper surface finish/color.
- 5) Edge trim color (laminate only).
- 6) Understructure trim color. Grade B, add **\$43.26** list.
- 7) Trim color. Grade B, add **\$43.26** list.

Overall Width	Number	1	Upper Top Laminate Grade A	Grade B	Wood Group A	Group B	Solid Surface
Paint Grade A Lower Top							
138”(3505mm)	THRD-48D8-TFS	EGBP	\$ 8437.28	\$ 8647.12	N/A	N/A	N/A
	THRD-48D8-HUS	EGBP	N/A	N/A	N/A	N/A	\$18923.28
	THRD-48D8-IUS	EGBP	N/A	N/A	\$ 9907.28	\$10481.28	N/A
Paint Grade B Lower Top							
138”(3505mm)	THRD-48D8-TFS	EGBP	\$ 8459.99	\$ 8669.83	N/A	N/A	N/A
	THRD-48D8-HUS	EGBP	N/A	N/A	N/A	N/A	\$18945.99
	THRD-48D8-IUS	EGBP	N/A	N/A	\$ 9929.99	\$10503.99	N/A
Laminate Grade A Lower Top							
138”(3505mm)	THRD-48D8-LFS	EGBP	\$ 6517.28	\$ 6727.12	N/A	N/A	N/A
	THRD-48D8-JFS	EGBP	N/A	N/A	N/A	N/A	\$17003.28
	THRD-48D8-QFS	EGBP	N/A	N/A	\$ 8561.28	\$ 8561.28	N/A
Laminate Grade B Lower Top							
138”(3505mm)	THRD-48D8-LFS	EGBP	\$ 6766.32	\$ 6976.16	N/A	N/A	N/A
	THRD-48D8-JFS	EGBP	N/A	N/A	N/A	N/A	\$17252.32
	THRD-48D8-QFS	EGBP	N/A	N/A	\$ 8810.32	\$ 8810.32	N/A
Solid Surface Lower Top							
138”(3505mm)	THRD-48D8-KFS	EGBP	\$19939.36	\$20149.20	N/A	N/A	N/A
	THRD-48D8-SSS	EGBP	N/A	N/A	N/A	N/A	\$30425.36
	THRD-48D8-EUS	EGBP	N/A	N/A	\$21409.36	\$21983.36	N/A
Wood Group A Lower Top							
138”(3505mm)	THRD-48D8-RFS	EGBP	\$ 8398.88	\$ 8608.72	N/A	N/A	N/A
	THRD-48D8-DUS	EGBP	N/A	N/A	N/A	N/A	\$18884.88
	THRD-48D8-WUS	EGBP	N/A	N/A	\$ 9868.88	\$10442.88	N/A
Wood Group B Lower Top							
138”(3505mm)	THRD-48D8-RFS	EGBP	\$ 9133.60	\$ 9343.44	N/A	N/A	N/A
	THRD-48D8-DUS	EGBP	N/A	N/A	N/A	N/A	\$19619.60
	THRD-48D8-WUS	EGBP	N/A	N/A	\$10603.60	\$11177.60	N/A

Immerse — Overlap Table

Racetrack/Round – Painted Legs

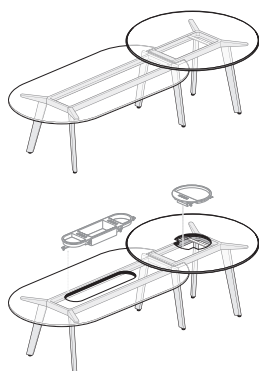

THTD

Features

- Includes lower racetrack top, upper round top, painted understructure, six painted metal legs, adjustable glides and hardware.
- Tops: Racetrack lower top available painted, laminate, solid surface and wood veneer with knife edge. Round upper top available in laminate, solid surface or wood veneer with knife edge. Round upper top not available painted.
 - Painted 1 1/8”(29mm) thick
 - Laminate and wood veneer 1 3/16”(30mm) thick
 - Solid surface 1”(25mm) thick
- Solid surface is standard in Cameo White.
- Glides have 1/2”(13mm) height adjustment and are standard in black.
- Depth and width shown in nominal dimensions.
- Ships unassembled.

Specification Tips

- Separately specified power available. Use Oblong Planter (EHPO-____) for the racetrack top and Round Planter (EHPR-____) for the round top.
- When cutout option (-L) is selected, the cutout is on the lower top, option (-P) the cutout is on the lower and upper top and option (-U) the cutout is on the upper top only.
- Overlap of top and bottom surfaces is 16 1/4”(413mm).
- Seating capacity of 8 based upon 27”(686mm) per chair.
- Tops share one understructure and are not designed to be separated.

To Order, Specify:

1) Product number, including:

1) Cutout Option:

- N** No Cutout
- L** Cutout - Lower Top, add **\$133.04** list
- P** Cutout - Lower and Upper Top, add **\$266.08** list
- U** Cutout - Upper Top, add **\$133.04** list

- Lower surface finish/color.
- Edge trim color (laminate only).
- Upper surface finish/color.
- Edge trim color (laminate only).
- Understructure trim color. Grade B, add **\$43.26** list.
- Trim color. Grade B, add **\$43.26** list.

Lower Top Dimensions

Height	Depth	Width
29”(737mm)	48”(1219mm)	96”(2438mm)

Upper Top Dimensions

Height	Diameter
30.5”(775mm)	60”(1524mm)

Overall Width	Number	1	Upper Top Laminate Grade A	Grade B	Wood Group A	Group B	Solid Surface
Paint Grade A Lower Top							
138”(3505mm)	THTD-48D8-TFS	EGBP	\$ 8437.28	\$ 8647.12	N/A	N/A	N/A
	THTD-48D8-HUS	EGBP	N/A	N/A	N/A	N/A	\$18923.28
	THTD-48D8-IUS	EGBP	N/A	N/A	\$ 9907.28	\$10481.28	N/A
Paint Grade B Lower Top							
138”(3505mm)	THTD-48D8-TFS	EGBP	\$ 8459.99	\$ 8669.83	N/A	N/A	N/A
	THTD-48D8-HUS	EGBP	N/A	N/A	N/A	N/A	\$18945.99
	THTD-48D8-IUS	EGBP	N/A	N/A	\$ 9929.99	\$10503.99	N/A
Laminate Grade A Lower Top							
138”(3505mm)	THTD-48D8-LFS	EGBP	\$ 6517.28	\$ 6727.12	N/A	N/A	N/A
	THTD-48D8-JFS	EGBP	N/A	N/A	N/A	N/A	\$17003.28
	THTD-48D8-QFS	EGBP	N/A	N/A	\$ 8561.28	\$ 8561.28	N/A
Laminate Grade B Lower Top							
138”(3505mm)	THTD-48D8-LFS	EGBP	\$ 6766.32	\$ 6976.16	N/A	N/A	N/A
	THTD-48D8-JFS	EGBP	N/A	N/A	N/A	N/A	\$17252.32
	THTD-48D8-QFS	EGBP	N/A	N/A	\$ 8810.32	\$ 8810.32	N/A
Solid Surface Lower Top							
138”(3505mm)	THTD-48D8-KFS	EGBP	\$19939.36	\$20149.20	N/A	N/A	N/A
	THTD-48D8-SSS	EGBP	N/A	N/A	N/A	N/A	\$30425.36
	THTD-48D8-EUS	EGBP	N/A	N/A	\$21409.36	\$21983.36	N/A
Wood Group A Lower Top							
138”(3505mm)	THTD-48D8-RFS	EGBP	\$ 8398.88	\$ 8608.72	N/A	N/A	N/A
	THTD-48D8-DUS	EGBP	N/A	N/A	N/A	N/A	\$18884.88
	THTD-48D8-WUS	EGBP	N/A	N/A	\$ 9868.88	\$10442.88	N/A
Wood Group B Lower Top							
138”(3505mm)	THTD-48D8-RFS	EGBP	\$ 9133.60	\$ 9343.44	N/A	N/A	N/A
	THTD-48D8-DUS	EGBP	N/A	N/A	N/A	N/A	\$19619.60
	THTD-48D8-WUS	EGBP	N/A	N/A	\$10603.60	\$11177.60	N/A

Immerse — Overlap Table

Rectangle/Ledge – Painted Legs

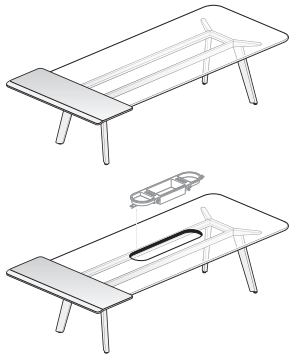

THRL

Features

- Includes one ledge upper top with 1/2”(7mm) spacer attached and one rectangle lower top, painted understructure, four painted metal legs, adjustable glides and hardware.
- Upper ledge top 1/2”(13mm) laminate or wood veneer with waterfall edge.
- Rectangle lower top available laminate, solid surface and wood veneer with knife edge.
 - Laminate and wood veneer 1 3/16”(30mm) thick
 - Solid surface 1”(25mm) thick
- Solid surface is standard in Cameo White.
- Ledge wood top is hardboard laminated core.
- Glides have 1/2”(13mm) height adjustment and are standard in black.
- Depth and width shown in nominal dimensions.
- Ships unassembled.

Specification Tips

- Separately specified power available. Use Oblong Planter (EHPO-____).
- When cutout option (-L) is selected, the cutout is on the lower top only.
- Overlap of top and bottom surfaces is 17 3/4”(451mm).
- Seating capacity of 9 based upon 27”(686mm) per chair.
- Tops share one understructure and are not designed to be separated.

Lower Top Dimensions

Height	Depth	Width
29”(737mm)	48”(1219mm)	120”(3048mm)

Upper Top Dimensions

Height	Depth	Width
30.5”(775mm)	57”(1448mm)	22”(559mm)

To Order, Specify:

- 1) Product number, including:

1 Cutout Option:

- N** No Cutout
- L** Cutout - Lower Top, add **\$133.04** list

- 2) Lower surface finish/color.
- 3) Edge trim color (laminate only).
- 4) Upper surface finish/color.
- 5) Understructure trim color. Grade B, add **\$43.26** list.
- 6) Trim color. Grade B, add **\$43.26** list.

Overall Width	Number	1	Upper Top		Wood	
			Laminate Grade A	Grade B	Group A	Group B
Laminate Grade A Lower Top						
124”(3150mm)	THRL-48C4-LFS	EGBP	\$ 5482.41	\$ 5698.12	N/A	N/A
	THRL-48C4-QFS	EGBP	N/A	N/A	\$ 5900.66	\$ 5900.66
Laminate Grade B Lower Top						
124”(3150mm)	THRL-48C4-LFS	EGBP	\$ 5776.25	\$ 5991.96	N/A	N/A
	THRL-48C4-QFS	EGBP	N/A	N/A	\$ 6194.50	\$ 6194.50
Solid Surface Lower Top						
124”(3150mm)	THRL-48C4-KFS	EGBP	\$22260.01	\$22475.72	N/A	N/A
	THRL-48C4-ESS	EGBP	N/A	N/A	\$22477.36	\$22678.26
Wood Group A Lower Top						
124”(3150mm)	THRL-48C4-RFS	EGBP	\$ 7834.41	\$ 8050.12	N/A	N/A
	THRL-48C4-WUS	EGBP	N/A	N/A	\$ 8051.76	\$ 8252.66
Wood Group B Lower Top						
124”(3150mm)	THRL-48C4-RFS	EGBP	\$ 8752.81	\$ 8968.52	N/A	N/A
	THRL-48C4-WUS	EGBP	N/A	N/A	\$ 8970.16	\$ 9171.06

This page intentionally blank

Immerse — Overlap Table

Rectangle/Rectangle – Wood Legs



THRR

Features

- Includes two tops, painted understructure, six solid wood legs, adjustable glides and hardware.
- Tops: Lower top available in laminate, solid surface and wood veneer with knife edge. Lower top not available painted. Upper top available painted, laminate, solid surface or wood veneer with knife edge.
 - Painted 1 1/8”(29mm) thick
 - Laminate and wood veneer 1 3/16”(30mm) thick
 - Solid surface 1”(25mm) thick
- Solid surface is standard in Cameo White.
- Glides have 1/2”(13mm) height adjustment and are standard in black.
- Depth and width shown in nominal dimensions.
- Ships unassembled.

Specification Tips

- Power only available in the upper top.
- Separately specified power available. Use Oblong Planter (EHPO-____).
- When cutout option (-U) is selected, the cutout is on the upper top only.
- Overlap of top and bottom surfaces is 18 1/2”(470mm).
- Seating capacity of 11 based upon 27”(686mm) per chair.
- Tops share one understructure and are not designed to be separated.

Lower Top Dimensions

Height	Depth	Width
29”(737mm)	60”(1524mm)	78”(1981mm)
37.5”(953mm)	60”(1524mm)	78”(1981mm)

Upper Top Dimensions

Height	Depth	Width
30.5”(775mm)	48”(1219mm)	96”(2438mm)
39”(991mm)	48”(1219mm)	96”(2438mm)

To Order, Specify:

- 1) Product number, including:

1 Cutout Option:

- N** No Cutout
- U** Cutout - Upper Top, add **\$133.04** list

- 2) Lower surface finish/color.
- 3) Edge trim color (laminate only).
- 4) Upper surface finish/color.
- 5) Edge trim color (laminate only).
- 6) Understructure trim color. Grade B, add **\$43.26** list.
- 7) Wood leg finish.
 - M7-W43 Ink on Ash - no upcharge
 - M5-W35 Clear on White Oak, add **\$220.90** list
 - M6-W35 Clear on Walnut, add **\$667.64** list

Immerse — Overlap Table

Rectangle/Rectangle – Wood Legs

Overall Width	Number	①	Upper Top Laminate Grade A	Grade B	Paint Grade A	Grade B	Wood Group A	Group B	Solid Surface	
Laminate Grade A Lower Top – 29”(737mm) Height										
156”(3962mm)	THRR-60F6-MFS	■	EGBW	N/A	N/A	\$12496.96	\$12519.67	N/A	N/A	N/A
	THRR-60F6-LFS	■	EGBW	\$10576.96	\$10826.00	N/A	N/A	N/A	N/A	N/A
	THRR-60F6-JFS	■	EGBW	N/A	N/A	N/A	N/A	N/A	N/A	\$23999.04
	THRR-60F6-QFS	■	EGBW	N/A	N/A	N/A	N/A	\$13193.28	\$13193.28	N/A
Laminate Grade A Lower Top – 37.5”(953mm) Height										
156”(3962mm)	THRR-60F6-MFS	■	EGCW	N/A	N/A	\$12662.47	\$12685.18	N/A	N/A	N/A
	THRR-60F6-LSS	■	EGCW	\$10742.47	\$10991.51	N/A	N/A	N/A	N/A	N/A
	THRR-60F6-JFS	■	EGCW	N/A	N/A	N/A	N/A	N/A	N/A	\$24164.55
	THRR-60F6-QFS	■	EGCW	N/A	N/A	N/A	N/A	\$13358.79	\$13358.79	N/A
Laminate Grade B Lower Top – 29”(737mm) Height										
156”(3962mm)	THRR-60F6-MFS	■	EGBW	N/A	N/A	\$12748.80	\$12771.51	N/A	N/A	N/A
	THRR-60F6-LFS	■	EGBW	\$10828.80	\$11077.84	N/A	N/A	N/A	N/A	N/A
	THRR-60F6-JFS	■	EGBW	N/A	N/A	N/A	N/A	N/A	N/A	\$24250.88
	THRR-60F6-QFS	■	EGBW	N/A	N/A	N/A	N/A	\$13445.12	\$13445.12	N/A
Laminate Grade B Lower Top – 37.5”(953mm) Height										
156”(3962mm)	THRR-60F6-MFS	■	EGCW	N/A	N/A	\$12914.31	\$12937.02	N/A	N/A	N/A
	THRR-60F6-LSS	■	EGCW	\$10994.31	\$11243.35	N/A	N/A	N/A	N/A	N/A
	THRR-60F6-JFS	■	EGCW	N/A	N/A	N/A	N/A	N/A	N/A	\$24416.39
	THRR-60F6-QFS	■	EGCW	N/A	N/A	N/A	N/A	\$13610.63	\$13610.63	N/A
Solid Surface Lower Top – 29”(737mm) Height										
156”(3962mm)	THRR-60F6-FUS	■	EGBW	N/A	N/A	\$26128.76	\$26151.47	N/A	N/A	N/A
	THRR-60F6-KFS	■	EGBW	\$24208.76	\$24457.80	N/A	N/A	N/A	N/A	N/A
	THRR-60F6-SSS	■	EGBW	N/A	N/A	N/A	N/A	N/A	N/A	\$37630.84
	THRR-60F6-EUS	■	EGBW	N/A	N/A	N/A	N/A	\$26090.36	\$26825.08	N/A
Solid Surface Lower Top – 37.5”(953mm) Height										
156”(3962mm)	THRR-60F6-FUS	■	EGCW	N/A	N/A	\$26294.27	\$26316.98	N/A	N/A	N/A
	THRR-60F6-KFS	■	EGCW	\$24374.27	\$24623.31	N/A	N/A	N/A	N/A	N/A
	THRR-60F6-SSS	■	EGCW	N/A	N/A	N/A	N/A	N/A	N/A	\$37796.35
	THRR-60F6-EUS	■	EGCW	N/A	N/A	N/A	N/A	\$26255.87	\$26990.59	N/A
Wood Group A Lower Top – 29”(737mm) Height										
156”(3962mm)	THRR-60F6-GUS	■	EGBW	N/A	N/A	\$14407.96	\$14430.67	N/A	N/A	N/A
	THRR-60F6-RFS	■	EGBW	\$12487.96	\$12737.00	N/A	N/A	N/A	N/A	N/A
	THRR-60F6-DUS	■	EGBW	N/A	N/A	N/A	N/A	N/A	N/A	\$25910.04
	THRR-60F6-WUS	■	EGBW	N/A	N/A	N/A	N/A	\$14369.56	\$15104.28	N/A
Wood Group A Lower Top – 37.5”(953mm) Height										
156”(3962mm)	THRR-60F6-GUS	■	EGCW	N/A	N/A	\$14573.47	\$14596.18	N/A	N/A	N/A
	THRR-60F6-RFS	■	EGCW	\$12653.47	\$12902.51	N/A	N/A	N/A	N/A	N/A
	THRR-60F6-DUS	■	EGCW	N/A	N/A	N/A	N/A	N/A	N/A	\$26075.55
	THRR-60F6-WUS	■	EGCW	N/A	N/A	N/A	N/A	\$14535.07	\$15269.79	N/A
Wood Group B Lower Top – 29”(737mm) Height										
156”(3962mm)	THRR-60F6-GUS	■	EGBW	N/A	N/A	\$15154.16	\$15176.87	N/A	N/A	N/A
	THRR-60F6-RFS	■	EGBW	\$13234.16	\$13234.16	N/A	N/A	N/A	N/A	N/A
	THRR-60F6-DUS	■	EGBW	N/A	N/A	N/A	N/A	N/A	N/A	\$26656.24
	THRR-60F6-WUS	■	EGBW	N/A	N/A	N/A	N/A	\$15115.76	\$15850.48	N/A
Wood Group B Lower Top – 37.5”(953mm) Height										
156”(3962mm)	THRR-60F6-GUS	■	EGCW	N/A	N/A	\$15319.67	\$15342.38	N/A	N/A	N/A
	THRR-60F6-RFS	■	EGCW	\$13399.67	\$13399.67	N/A	N/A	N/A	N/A	N/A
	THRR-60F6-DUS	■	EGCW	N/A	N/A	N/A	N/A	N/A	N/A	\$26821.75
	THRR-60F6-WUS	■	EGCW	N/A	N/A	N/A	N/A	\$15281.27	\$16015.99	N/A

Immerse — Overlap Table

Rectangle/Round – Wood Legs

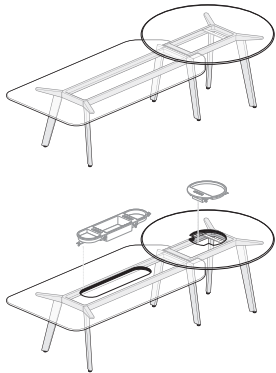

THRD

Features

- Includes lower racetrack top, upper round top, painted understructure, six solid wood legs, adjustable glides and hardware.
- Tops: Rectangle lower top available painted, laminate, solid surface and wood veneer with knife edge. Round upper top available in laminate, solid surface or wood veneer with knife edge. Round upper top not available painted.
 - Painted 1 1/8”(29mm) thick
 - Laminate and wood veneer 1 3/16”(30mm) thick
 - Solid surface 1”(25mm) thick
- Solid surface is standard in Cameo White.
- Glides have 1/2”(13mm) height adjustment and are standard in black.
- Depth and width shown in nominal dimensions.
- Ships unassembled.

Specification Tips

- Separately specified power available. Use Oblong Planter (EHPO-____) for the rectangle top and Round Planter (EHPR-____) for the round top.
- When cutout option (-L) is selected, the cutout is on the lower top, option (-P) the cutout is on the lower and upper top and option (-U) the cutout is on the upper top only.
- Overlap of top and bottom surfaces is 15 3/4”(400mm).
- Seating capacity of 8 based upon 27”(686mm) per chair.
- Tops share one understructure and are not designed to be separated.

Lower Top Dimensions

Height	Depth	Width
29”(737mm)	48”(1219mm)	96”(2438mm)

Upper Top Dimensions

Height	Diameter
30.5”(775mm)	60”(1524mm)

To Order, Specify:

1) Product number, including:

1 Cutout Option:

- N** No Cutout
- L** Cutout - Lower Top, add **\$133.04** list
- P** Cutout - Lower and Upper Top, add **\$266.08** list
- U** Cutout - Upper Top, add **\$133.04** list

2) Lower surface finish/color.

3) Edge trim color (laminate only).

4) Upper surface finish/color.

5) Edge trim color (laminate only).

6) Understructure trim color. Grade B, add **\$43.26** list.

7) Wood leg finish.

M7-W43 Ink on Ash - no upcharge

M5-W35 Clear on White Oak, add **\$220.90** list

M6-W35 Clear on Walnut, add **\$667.64** list

Overall Width	Number	1	Upper Top Laminate Grade A	Grade B	Wood Group A	Group B	Solid Surface
Paint Grade A Lower Top							
138”(3505mm)	THRD-48D8-TFS	EGBW	\$11949.16	\$12159.00	N/A	N/A	N/A
	THRD-48D8-HUS	EGBW	N/A	N/A	N/A	N/A	\$22435.16
	THRD-48D8-IUS	EGBW	N/A	N/A	\$13419.16	\$13993.16	N/A
Paint Grade B Lower Top							
138”(3505mm)	THRD-48D8-TFS	EGBW	\$11971.87	\$12181.71	N/A	N/A	N/A
	THRD-48D8-HUS	EGBW	N/A	N/A	N/A	N/A	\$22457.87
	THRD-48D8-IUS	EGBW	N/A	N/A	\$13441.87	\$14015.87	N/A
Laminate Grade A Lower Top							
138”(3505mm)	THRD-48D8-LFS	EGBW	\$10029.16	\$10239.00	N/A	N/A	N/A
	THRD-48D8-JFS	EGBW	N/A	N/A	N/A	N/A	\$20515.16
	THRD-48D8-QFS	EGBW	N/A	N/A	\$12073.16	\$12073.16	N/A
Laminate Grade B Lower Top							
138”(3505mm)	THRD-48D8-LFS	EGBW	\$10278.20	\$10488.04	N/A	N/A	N/A
	THRD-48D8-JFS	EGBW	N/A	N/A	N/A	N/A	\$20764.20
	THRD-48D8-QFS	EGBW	N/A	N/A	\$12322.20	\$12322.20	N/A
Solid Surface Lower Top							
138”(3505mm)	THRD-48D8-KFS	EGBW	\$23451.24	\$23661.08	N/A	N/A	N/A
	THRD-48D8-SSS	EGBW	N/A	N/A	N/A	N/A	\$33937.24
	THRD-48D8-EUS	EGBW	N/A	N/A	\$24921.24	\$25495.24	N/A
Wood Group A Lower Top							
138”(3505mm)	THRD-48D8-RFS	EGBW	\$11910.76	\$12120.60	N/A	N/A	N/A
	THRD-48D8-DUS	EGBW	N/A	N/A	N/A	N/A	\$22396.76
	THRD-48D8-WUS	EGBW	N/A	N/A	\$13380.76	\$13954.76	N/A
Wood Group B Lower Top							
138”(3505mm)	THRD-48D8-RFS	EGBW	\$12645.48	\$12645.48	N/A	N/A	N/A
	THRD-48D8-DUS	EGBW	N/A	N/A	N/A	N/A	\$23131.48
	THRD-48D8-WUS	EGBW	N/A	N/A	\$14115.48	\$14689.48	N/A

Immerse — Overlap Table

Racetrack/Round – Wood Legs

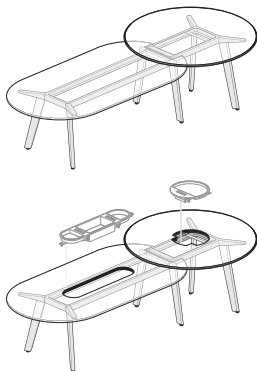

THTD

Features

- Includes lower racetrack top, upper round top, painted understructure, six solid wood legs, adjustable glides and hardware.
- Tops: Racetrack lower top available painted, laminate, solid surface and wood veneer with knife edge. Round upper top available in laminate, solid surface or wood veneer with knife edge. Round upper top not available painted.
 - Painted 1 1/8”(29mm) thick
 - Laminate and wood veneer 1 3/16”(30mm) thick
 - Solid surface 1”(25mm) thick
- Solid surface is standard in Cameo White.
- Glides have 1/2”(13mm) height adjustment and are standard in black.
- Depth and width shown in nominal dimensions.
- Ships unassembled.

Specification Tips

- Separately specified power available. Use Oblong Planter (EHPO-____) for the racetrack top and Round Planter (EHPR-____) for the round top.
- When cutout option (-L) is selected, the cutout is on the lower top, option (-P) the cutout is on the lower and upper top and option (-U) the cutout is on the upper top only.
- Overlap of top and bottom surfaces is 16 1/4”(413mm).
- Seating capacity of 8 based upon 27”(686mm) per chair.
- Tops share one understructure and are not designed to be separated.

To Order, Specify:

1) Product number, including:

1) Cutout Option:

- N** No Cutout
- L** Cutout - Lower Top, add **\$133.04** list
- P** Cutout - Lower and Upper Top, add **\$266.08** list
- U** Cutout - Upper Top, add **\$133.04** list

- Lower surface finish/color.
- Edge trim color (laminate only).
- Upper surface finish/color.
- Edge trim color (laminate only).
- Understructure trim color. Grade B, add **\$43.26** list.
- Wood leg finish.
 - M7-W43 Ink on Ash - no upcharge
 - M5-W35 Clear on White Oak, add **\$220.90** list
 - M6-W35 Clear on Walnut, add **\$667.64** list

Lower Top Dimensions

Height	Depth	Width
29”(737mm)	48”(1219mm)	96”(2438mm)

Upper Top Dimensions

Height	Diameter
30.5”(775mm)	60”(1524mm)

Overall Width	Number	1	Upper Top Laminate Grade A	Grade B	Wood Group A	Group B	Solid Surface
Paint Grade A Lower Top							
138”(3505mm)	THTD-48D8-TFS	EGBW	\$11949.16	\$12159.00	N/A	N/A	N/A
	THTD-48D8-HUS	EGBW	N/A	N/A	N/A	N/A	\$22435.16
	THTD-48D8-IUS	EGBW	N/A	N/A	\$13419.16	\$13993.16	N/A
Paint Grade B Lower Top							
138”(3505mm)	THTD-48D8-TFS	EGBW	\$11971.87	\$12181.71	N/A	N/A	N/A
	THTD-48D8-HUS	EGBW	N/A	N/A	N/A	N/A	\$22457.87
	THTD-48D8-IUS	EGBW	N/A	N/A	\$13441.87	\$14015.87	N/A
Laminate Grade A Lower Top							
138”(3505mm)	THTD-48D8-LFS	EGBW	\$10029.16	\$10239.00	N/A	N/A	N/A
	THTD-48D8-JFS	EGBW	N/A	N/A	N/A	N/A	\$20515.16
	THTD-48D8-QFS	EGBW	N/A	N/A	\$12073.16	\$12073.16	N/A
Laminate Grade B Lower Top							
138”(3505mm)	THTD-48D8-LFS	EGBW	\$10278.20	\$10488.04	N/A	N/A	N/A
	THTD-48D8-JFS	EGBW	N/A	N/A	N/A	N/A	\$20764.20
	THTD-48D8-QFS	EGBW	N/A	N/A	\$12322.20	\$12322.20	N/A
Solid Surface Lower Top							
138”(3505mm)	THTD-48D8-KFS	EGBW	\$23451.24	\$23661.08	N/A	N/A	N/A
	THTD-48D8-SSS	EGBW	N/A	N/A	N/A	N/A	\$33937.24
	THTD-48D8-EUS	EGBW	N/A	N/A	\$24921.24	\$25495.24	N/A
Wood Group A Lower Top							
138”(3505mm)	THTD-48D8-RFS	EGBW	\$11910.76	\$12120.60	N/A	N/A	N/A
	THTD-48D8-DUS	EGBW	N/A	N/A	N/A	N/A	\$22396.76
	THTD-48D8-WUS	EGBW	N/A	N/A	\$13380.76	\$13954.76	N/A
Wood Group B Lower Top							
138”(3505mm)	THTD-48D8-RFS	EGBW	\$12645.48	\$12645.48	N/A	N/A	N/A
	THTD-48D8-DUS	EGBW	N/A	N/A	N/A	N/A	\$23131.48
	THTD-48D8-WUS	EGBW	N/A	N/A	\$14115.48	\$14689.48	N/A

Immerse — Overlap Table

Rectangle/Ledge – Wood Legs

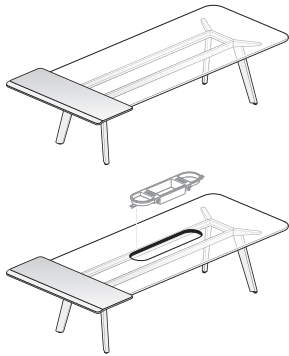

THRL

Features

- Includes one ledge upper top with 1/2”(7mm) spacer attached and one rectangle lower top, painted understructure, four solid wood legs, adjustable glides and hardware.
- Upper ledge top 1/2”(13mm) laminate or wood veneer with waterfall edge.
- Rectangle lower top available laminate, solid surface and wood veneer with knife edge.
 - Laminate and wood veneer 1 3/16”(30mm) thick
 - Solid surface 1”(25mm) thick
- Solid surface is standard in Cameo White.
- Ledge wood top is hardboard laminated core.
- Glides have 1/2”(13mm) height adjustment and are standard in black.
- Depth and width shown in nominal dimensions.
- Ships unassembled.

Specification Tips

- Separately specified power available. Use Oblong Planter (EHPO-____).
- When cutout option (-L) is selected, the cutout is on the lower top only.
- Overlap of top and bottom surfaces is 17 3/4”(451mm).
- Seating capacity of 9 based upon 27”(686mm) per chair.
- Tops share one understructure and are not designed to be separated.

Lower Top Dimensions

Height	Depth	Width
29”(737mm)	48”(1219mm)	120”(3048mm)

Upper Top Dimensions

Height	Depth	Width
30.5”(775mm)	57”(1448mm)	22”(559mm)

To Order, Specify:

- 1) Product number, including:

① Cutout Option:

- N** No Cutout
- L** Cutout - Lower Top, add **\$133.04** list

- 2) Lower surface finish/color.
- 3) Edge trim color (laminate only).
- 4) Upper surface finish/color.
- 5) Understructure trim color. Grade B, add **\$43.26** list.
- 6) Wood leg finish.
 - M7-W43 Ink on Ash - no upcharge
 - M5-W35 Clear on White Oak, add **\$147.90** list
 - M6-W35 Clear on Walnut, add **\$444.57** list

Overall Width	Number	①	Upper Top Laminate Grade A	Grade B	Wood Group A	Group B
Laminate Grade A Lower Top						
124”(3150mm)	THRL-48C4-LFS	EGBW	\$ 7875.99	\$ 8091.70	N/A	N/A
	THRL-48C4-QFS	EGBW	N/A	N/A	\$ 8294.24	\$ 8294.24
Laminate Grade B Lower Top						
124”(3150mm)	THRL-48C4-LFS	EGBW	\$ 8169.83	\$ 8385.54	N/A	N/A
	THRL-48C4-QFS	EGBW	N/A	N/A	\$ 8588.08	\$ 8588.08
Solid Surface Lower Top						
124”(3150mm)	THRL-48C4-KFS	EGBW	\$24653.59	\$24869.30	N/A	N/A
	THRL-48C4-ESS	EGBW	N/A	N/A	\$24870.94	\$25071.84
Wood Group A Lower Top						
124”(3150mm)	THRL-48C4-RFS	EGBW	\$10227.99	\$10443.70	N/A	N/A
	THRL-48C4-WUS	EGBW	N/A	N/A	\$10445.34	\$10646.24
Wood Group B Lower Top						
124”(3150mm)	THRL-48C4-RFS	EGBW	\$11146.39	\$11362.10	N/A	N/A
	THRL-48C4-WUS	EGBW	N/A	N/A	\$11363.74	\$11564.64

Immerse — Shift Table

Rectangle/Rectangle – Painted Legs

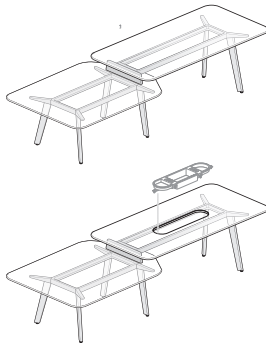

THRR

Features

- Includes two tops, 7”(178mm) high stack spacer, painted understructure, six painted metal legs, adjustable glides and hardware.
- Tops: Lower top available in laminate, solid surface and wood veneer with knife edge. Upper top available painted, laminate, solid surface or wood veneer with knife edge.
 - Painted 1 1/8”(29mm) thick
 - Laminate and wood veneer 1 3/16”(30mm) thick
 - Solid surface 1” thick
- Solid surface is standard in Cameo White.
- Stack spacer is painted MDF.
- Glides have 1/2”(13mm) height adjustment and are standard in black.
- Depth and width shown in nominal dimensions.
- Ships unassembled.

Specification Tips

- Separately specified power available. Use Oblong Planter (EHPO-_____).
- When cutout option (-U) is selected, cutout is on the upper top only. Lower top not available with cutout.
- Overlap of top and bottom surfaces is 18 1/2”(470mm).
- Seating capacity of 11 based upon 27”(686mm) per chair.
- Tops share one understructure and are not designed to be separated.

Lower Top Dimensions

Height	Depth	Width
29”(737mm)	60”(1524mm)	84”(2134mm)

Upper Top Dimensions

Height	Depth	Width
36”(914mm)	48”(1219mm)	96”(2438mm)

To Order, Specify:

- 1) Product number, including:

1) Cutout Option:

- N No Cutout
- U Cutout - Upper Top, add **\$133.04** list

- 2) Lower surface finish/color.
- 3) Edge trim color (laminate only).
- 4) Upper surface finish/color.
- 5) Edge trim color (laminate only).
- 6) Understructure trim color. Grade B, add **\$43.26** list.
- 7) Trim color. Grade B, add **\$43.26** list.
- 8) Stack spacer color.

Overall Width	Number	1	Upper Top		Paint Grade A	Grade B	Wood Group A	Group B	Solid Surface
			Laminate Grade A	Grade B					
Laminate Grade A Lower Top									
156”(3962mm)	THRR-60F6-MFS	<input type="checkbox"/> DGAP	N/A	N/A	\$ 9337.02	\$ 9359.73	N/A	N/A	N/A
	THRR-60F6-LFS	<input type="checkbox"/> DGAP	\$ 7417.02	\$ 7666.06	N/A	N/A	N/A	N/A	N/A
	THRR-60F6-JFS	<input type="checkbox"/> DGAP	N/A	N/A	N/A	N/A	N/A	N/A	\$20839.10
	THRR-60F6-QFS	<input type="checkbox"/> DGAP	N/A	N/A	N/A	N/A	\$10033.34	\$10033.34	N/A
Laminate Grade B Lower Top									
156”(3962mm)	THRR-60F6-MFS	<input type="checkbox"/> DGAP	N/A	N/A	\$ 9588.86	\$ 9611.57	N/A	N/A	N/A
	THRR-60F6-LFS	<input type="checkbox"/> DGAP	\$ 7668.86	\$ 7917.90	N/A	N/A	N/A	N/A	N/A
	THRR-60F6-JFS	<input type="checkbox"/> DGAP	N/A	N/A	N/A	N/A	N/A	N/A	\$21090.94
	THRR-60F6-QFS	<input type="checkbox"/> DGAP	N/A	N/A	N/A	N/A	\$10285.18	\$10285.18	N/A
Solid Surface Lower Top									
156”(3962mm)	THRR-60F6-FUS	<input type="checkbox"/> DGAP	N/A	N/A	\$22968.82	\$22991.53	N/A	N/A	N/A
	THRR-60F6-KFS	<input type="checkbox"/> DGAP	\$21048.82	\$21297.86	N/A	N/A	N/A	N/A	N/A
	THRR-60F6-SSS	<input type="checkbox"/> DGAP	N/A	N/A	N/A	N/A	N/A	N/A	\$34470.90
	THRR-60F6-EUS	<input type="checkbox"/> DGAP	N/A	N/A	N/A	N/A	\$22930.42	\$23665.14	N/A
Wood Group A Lower Top									
156”(3962mm)	THRR-60F6-GUS	<input type="checkbox"/> DGAP	N/A	N/A	\$11248.02	\$11270.73	N/A	N/A	N/A
	THRR-60F6-RFS	<input type="checkbox"/> DGAP	\$ 9328.02	\$ 9577.06	N/A	N/A	N/A	N/A	N/A
	THRR-60F6-DUS	<input type="checkbox"/> DGAP	N/A	N/A	N/A	N/A	N/A	N/A	\$22750.10
	THRR-60F6-WUS	<input type="checkbox"/> DGAP	N/A	N/A	N/A	N/A	\$11209.62	\$11944.34	N/A
Wood Group B Lower Top									
156”(3962mm)	THRR-60F6-GUS	<input type="checkbox"/> DGAP	N/A	N/A	\$11994.22	\$12016.93	N/A	N/A	N/A
	THRR-60F6-RFS	<input type="checkbox"/> DGAP	\$10074.22	\$10323.26	N/A	N/A	N/A	N/A	N/A
	THRR-60F6-DUS	<input type="checkbox"/> DGAP	N/A	N/A	N/A	N/A	N/A	N/A	\$23496.30
	THRR-60F6-WUS	<input type="checkbox"/> DGAP	N/A	N/A	N/A	N/A	\$11955.82	\$12690.54	N/A

Immerse — Shift Table

Rectangle/Round – Painted Legs

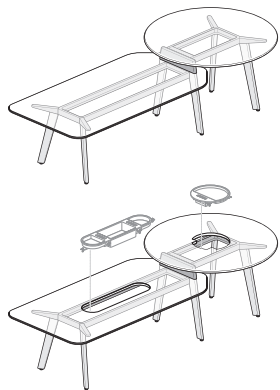

THRD

Features

- Includes rectangle lower top and round upper top, 7”(178mm) high stack spacer, painted understructure, six painted metal legs, adjustable glides and hardware.
- Tops: Rectangle lower top available painted, laminate, solid surface and wood veneer with knife edge. Round upper top available in laminate, solid surface or wood veneer with knife edge. Round upper top not available painted.
 - Painted 1 1/8”(29mm) thick
 - Laminate and wood veneer 1 3/16”(30mm) thick
 - Solid surface 1”(25mm) thick
- Solid surface is standard in Cameo White.
- Stack spacer is painted MDF.
- Glides have 1/2”(13mm) height adjustment and are standard in black.
- Depth and width shown in nominal dimensions.
- Ships unassembled.

Specification Tips

- Separately specified power available. Use Oblong Planter (EHPO-_____) for the rectangle top and Round Planter (EHPR-_____) for the round top.
- When cutout option (-L) is selected, the cutout is on the lower top, option (-P) the cutout is on the lower and upper top and option (-U) the cutout is on the upper top only.
- Overlap of top and bottom surfaces is 15 3/4”(400mm).
- Seating capacity of 8 based upon 27”(686mm) per chair.
- Tops share one understructure and are not designed to be separated.

Lower Top Dimensions

Height	Depth	Width
29”(737mm)	48”(1219mm)	96”(2438mm)

Upper Top Dimensions

Height	Diameter
36”(914mm)	60”(1524mm)

To Order, Specify:

1) Product number, including:

1 Cutout Option:

- N** No Cutout
- L** Cutout - Lower Top, add **\$133.04** list
- P** Cutout - Lower and Upper Top, add **\$266.08** list
- U** Cutout - Upper Top, add **\$133.04** list

- 2) Lower surface finish/color.
- 3) Edge trim color (laminate only).
- 4) Upper surface finish/color.
- 5) Edge trim color (laminate only).
- 6) Understructure trim color. Grade B, add **\$43.26** list.
- 7) Trim color. Grade B, add **\$43.26** list.
- 8) Stack spacer color.

Overall Width	Number	1	Upper Top		Wood Group A	Group B	Solid Surface
			Laminate Grade A	Grade B			
Paint Grade A Lower Top							
138”(3505mm)	THRD-48D8-TFS	DGAP	\$ 8789.22	\$ 8999.06	N/A	N/A	N/A
	THRD-48D8-HUS	DGAP	N/A	N/A	N/A	N/A	\$19275.22
	THRD-48D8-IUS	DGAP	N/A	N/A	\$10259.22	\$10833.22	N/A
Paint Grade B Lower Top							
138”(3505mm)	THRD-48D8-TFS	DGAP	\$ 8811.93	\$ 9021.77	N/A	N/A	N/A
	THRD-48D8-HUS	DGAP	N/A	N/A	N/A	N/A	\$19297.93
	THRD-48D8-IUS	DGAP	N/A	N/A	\$10281.93	\$10855.93	N/A
Laminate Grade A Lower Top							
138”(3505mm)	THRD-48D8-LFS	DGAP	\$ 6869.22	\$ 7079.06	N/A	N/A	N/A
	THRD-48D8-JFS	DGAP	N/A	N/A	N/A	N/A	\$17355.22
	THRD-48D8-QFS	DGAP	N/A	N/A	\$ 8913.22	\$ 8913.22	N/A
Laminate Grade B Lower Top							
138”(3505mm)	THRD-48D8-LFS	DGAP	\$ 7118.26	\$ 7328.10	N/A	N/A	N/A
	THRD-48D8-JFS	DGAP	N/A	N/A	N/A	N/A	\$17604.26
	THRD-48D8-QFS	DGAP	N/A	N/A	\$ 9162.26	\$ 9162.26	N/A
Solid Surface Lower Top							
138”(3505mm)	THRD-48D8-KFS	DGAP	\$20291.30	\$20501.14	N/A	N/A	N/A
	THRD-48D8-SSS	DGAP	N/A	N/A	N/A	N/A	\$30777.30
	THRD-48D8-EUS	DGAP	N/A	N/A	\$21761.30	\$22335.30	N/A
Wood Group A Lower Top							
138”(3505mm)	THRD-48D8-RFS	DGAP	\$ 8750.82	\$ 8960.66	N/A	N/A	N/A
	THRD-48D8-DUS	DGAP	N/A	N/A	N/A	N/A	\$19236.82
	THRD-48D8-WUS	DGAP	N/A	N/A	\$10220.82	\$10794.82	N/A
Wood Group B Lower Top							
138”(3505mm)	THRD-48D8-RFS	DGAP	\$ 9485.54	\$ 9695.38	N/A	N/A	N/A
	THRD-48D8-DUS	DGAP	N/A	N/A	N/A	N/A	\$19971.54
	THRD-48D8-WUS	DGAP	N/A	N/A	\$10955.54	\$11529.54	N/A

Immerse — Shift Table

Racetrack/Round – Painted Legs

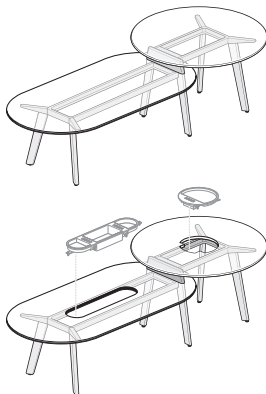

THTD

Features

- Includes racetrack lower top and round upper top, 7”(178mm) high stack spacer, painted understructure, six painted metal legs, adjustable glides and hardware.
- Tops: Racetrack lower top available painted, laminate, solid surface and wood veneer with knife edge. Round upper top available in laminate, solid surface or wood veneer with knife edge. Round upper top not available painted.
 - Painted 1 1/8”(29mm) thick
 - Laminate and wood veneer 1 3/16”(30mm) thick
 - Solid surface 1”(25mm) thick
- Solid surface is standard in Cameo White.
- Stack spacer is painted MDF.
- Glides have 1/2”(13mm) height adjustment and are standard in black.
- Depth and width shown in nominal dimensions.
- Ships unassembled.

Specification Tips

- Separately specified power available. Use Oblong Planter (EHPO-_____) for the racetrack top and Round Planter (EHPR-_____) for the round top.
- When cutout option (-L) is selected, the cutout is on the lower top, option (-P) the cutout is on the lower and upper top and option (-U) the cutout is on the upper top only.
- Overlap of top and bottom surfaces is 17 3/4”(451mm).
- Seating capacity of 8 based upon 27”(686mm) per chair.
- Tops share one understructure and are not designed to be separated.

Lower Top Dimensions

Height	Depth	Width
29”(737mm)	48”(1219mm)	96”(2438mm)

Upper Top Dimensions

Height	Diameter
36”(914mm)	60”(1524mm)

To Order, Specify:

- 1) Product number, including:

1) Cutout Option:

- N** No Cutout
- L** Cutout - Lower Top, add **\$133.04** list
- P** Cutout - Lower and Upper Top, add **\$266.08** list
- U** Cutout - Upper Top, add **\$133.04** list

- 2) Lower surface finish/color.
- 3) Edge trim color (laminate only).
- 4) Upper surface finish/color.
- 5) Edge trim color (laminate only).
- 6) Understructure trim color. Grade B, add **\$43.26** list.
- 7) Trim color. Grade B, add **\$43.26** list.
- 8) Stack spacer color.

Overall Width	Number	①	Upper Top		Wood Group A	Group B	Solid Surface
			Laminate Grade A	Grade B			
Paint Grade A Lower Top							
138”(3505mm)	THTD-48D8-TFS	DGAP	\$ 8789.22	\$ 8999.06	N/A	N/A	N/A
	THTD-48D8-HUS	DGAP	N/A	N/A	N/A	N/A	\$19275.22
	THTD-48D8-IUS	DGAP	N/A	N/A	\$10259.22	\$10833.22	N/A
Paint Grade B Lower Top							
138”(3505mm)	THTD-48D8-TFS	DGAP	\$ 8811.93	\$ 9021.77	N/A	N/A	N/A
	THTD-48D8-HUS	DGAP	N/A	N/A	N/A	N/A	\$19297.93
	THTD-48D8-IUS	DGAP	N/A	N/A	\$10281.93	\$10855.93	N/A
Laminate Grade A Lower Top							
138”(3505mm)	THTD-48D8-LFS	DGAP	\$ 6869.22	\$ 7079.06	N/A	N/A	N/A
	THTD-48D8-JFS	DGAP	N/A	N/A	N/A	N/A	\$17355.22
	THTD-48D8-QFS	DGAP	N/A	N/A	\$ 8913.22	\$ 8913.22	N/A
Laminate Grade B Lower Top							
138”(3505mm)	THTD-48D8-LFS	DGAP	\$ 7118.26	\$ 7328.10	N/A	N/A	N/A
	THTD-48D8-JFS	DGAP	N/A	N/A	N/A	N/A	\$17604.26
	THTD-48D8-QFS	DGAP	N/A	N/A	\$ 9162.26	\$ 9162.26	N/A
Solid Surface Lower Top							
138”(3505mm)	THTD-48D8-KFS	DGAP	\$20291.30	\$20501.14	N/A	N/A	N/A
	THTD-48D8-SSS	DGAP	N/A	N/A	N/A	N/A	\$30777.30
	THTD-48D8-EUS	DGAP	N/A	N/A	\$21761.30	\$22335.30	N/A
Wood Group A Lower Top							
138”(3505mm)	THTD-48D8-RFS	DGAP	\$ 8750.82	\$ 8960.66	N/A	N/A	N/A
	THTD-48D8-DUS	DGAP	N/A	N/A	N/A	N/A	\$19236.82
	THTD-48D8-WUS	DGAP	N/A	N/A	\$10220.82	\$10794.82	N/A
Wood Group B Lower Top							
138”(3505mm)	THTD-48D8-RFS	DGAP	\$ 9485.54	\$ 9695.38	N/A	N/A	N/A
	THTD-48D8-DUS	DGAP	N/A	N/A	N/A	N/A	\$19971.54
	THTD-48D8-WUS	DGAP	N/A	N/A	\$10955.54	\$11529.54	N/A

Immerse — Shift Table

Rectangle/Rectangle – Wood Legs

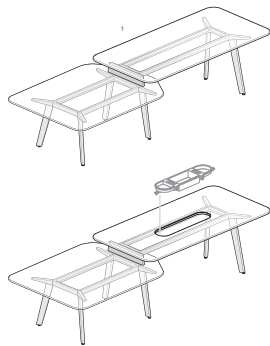

THRR

Features

- Includes two tops, 7"(178mm) high stack spacer, painted understructure, six solid wood legs, adjustable glides and hardware.
- Tops: Lower top available in laminate, solid surface and wood veneer with knife edge. Upper top available painted, laminate, solid surface or wood veneer with knife edge.
 - Painted 1 1/8"(29mm) thick
 - Laminate and wood veneer 1 3/16"(30mm) thick
 - Solid surface 1" thick
- Solid surface is standard in Cameo White.
- Stack spacer is painted MDF.
- Glides have 1/2"(13mm) height adjustment and are standard in black.
- Depth and width shown in nominal dimensions.
- Ships unassembled.

Specification Tips

- Separately specified power available. Use Oblong Planter (EHPO-_____).
- When cutout option (-U) is selected, cutout is on the upper top only. Lower top not available with cutout.
- Overlap of top and bottom surfaces is 18 1/2"(470mm).
- Seating capacity of 11 based upon 27"(686mm) per chair.
- Tops share one understructure and are not designed to be separated.

Lower Top Dimensions

Height	Depth	Width
29"(737mm)	60"(1524mm)	84"(2134mm)

Upper Top Dimensions

Height	Depth	Width
36"(914mm)	48"(1219mm)	96"(2438mm)

To Order, Specify:

- 1) Product number, including:
 - 1 Cutout Option:**
 - N** No Cutout
 - U** Cutout - Upper Top, add **\$133.04** list
- 2) Lower surface finish/color.
- 3) Edge trim color (laminate only).
- 4) Upper surface finish/color.
- 5) Edge trim color (laminate only).
- 6) Understructure trim color. Grade B, add **\$43.26** list.
- 7) Wood leg finish.
 - M7-W43 Ink on Ash - no upcharge
 - M5-W35 Clear on White Oak, add **\$227.75** list
 - M6-W35 Clear on Walnut, add **\$688.39** list
- 8) Stack spacer color.

Overall Width	Number	1	Upper Top		Paint Grade A	Grade B	Wood Group A	Group B	Solid Surface
			Laminate Grade A	Grade B					
Laminate Grade A Lower Top									
156"(3962mm)	THRR-60F6-MFS	DGAW	N/A	N/A	\$13227.02	\$13249.73	N/A	N/A	N/A
	THRR-60F6-LFS	DGAW	\$11307.02	\$11556.06	N/A	N/A	N/A	N/A	N/A
	THRR-60F6-JFS	DGAW	N/A	N/A	N/A	N/A	N/A	N/A	\$24729.10
	THRR-60F6-QFS	DGAW	N/A	N/A	N/A	N/A	\$13923.34	\$13923.34	N/A
Laminate Grade B Lower Top									
156"(3962mm)	THRR-60F6-MFS	DGAW	N/A	N/A	\$13478.86	\$13501.57	N/A	N/A	N/A
	THRR-60F6-LFS	DGAW	\$11558.86	\$11807.90	N/A	N/A	N/A	N/A	N/A
	THRR-60F6-JFS	DGAW	N/A	N/A	N/A	N/A	N/A	N/A	\$24980.94
	THRR-60F6-QFS	DGAW	N/A	N/A	N/A	N/A	\$14175.18	\$14175.18	N/A
Solid Surface Lower Top									
156"(3962mm)	THRR-60F6-FUS	DGAW	N/A	N/A	\$26858.82	\$26881.53	N/A	N/A	N/A
	THRR-60F6-KFS	DGAW	\$24938.82	\$25187.86	N/A	N/A	N/A	N/A	N/A
	THRR-60F6-SSS	DGAW	N/A	N/A	N/A	N/A	N/A	N/A	\$38360.90
	THRR-60F6-EUS	DGAW	N/A	N/A	N/A	N/A	\$26820.42	\$27555.14	N/A
Wood Group A Lower Top									
156"(3962mm)	THRR-60F6-GUS	DGAW	N/A	N/A	\$15138.02	\$15160.73	N/A	N/A	N/A
	THRR-60F6-RFS	DGAW	\$13218.02	\$13467.06	N/A	N/A	N/A	N/A	N/A
	THRR-60F6-DUS	DGAW	N/A	N/A	N/A	N/A	N/A	N/A	\$26640.10
	THRR-60F6-WUS	DGAW	N/A	N/A	N/A	N/A	\$15099.62	\$15834.34	N/A
Wood Group B Lower Top									
156"(3962mm)	THRR-60F6-GUS	DGAW	N/A	N/A	\$15884.22	\$15906.93	N/A	N/A	N/A
	THRR-60F6-RFS	DGAW	\$13964.22	\$14213.26	N/A	N/A	N/A	N/A	N/A
	THRR-60F6-DUS	DGAW	N/A	N/A	N/A	N/A	N/A	N/A	\$27386.30
	THRR-60F6-WUS	DGAW	N/A	N/A	N/A	N/A	\$15845.82	\$16580.54	N/A

Immerse — Shift Table

Rectangle/Round – Wood Legs

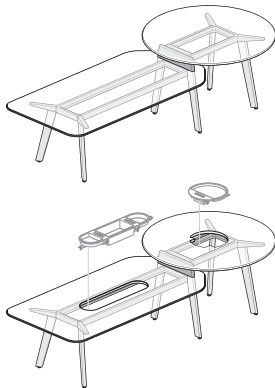

THRD

Features

- Includes rectangle lower top and round upper top, 7”(178mm) high stack spacer, painted understructure, six solid wood legs, adjustable glides and hardware.
- Tops: Rectangle lower top available painted, laminate, solid surface and wood veneer with knife edge. Round upper top available in laminate, solid surface or wood veneer with knife edge. Round upper top not available painted.
 - Painted 1 1/8”(29mm) thick
 - Laminate and wood veneer 1 3/16”(30mm) thick
 - Solid surface 1”(25mm) thick
- Solid surface is standard in Cameo White.
- Stack spacer is painted MDF.
- Glides have 1/2”(13mm) height adjustment and are standard in black.
- Depth and width shown in nominal dimensions.
- Ships unassembled.

Specification Tips

- Separately specified power available. Use Oblong Planter (EHPO-_____) for the rectangle top and Round Planter (EHPR-_____) for the round top.
- When cutout option (-L) is selected, the cutout is on the lower top, option (-P) the cutout is on the lower and upper top and option (-U) the cutout is on the upper top only.
- Overlap of top and bottom surfaces is 15 3/4”(400mm).
- Seating capacity of 8 based upon 27”(686mm) per chair.
- Tops share one understructure and are not designed to be separated.

Lower Top Dimensions

Height	Depth	Width
29”(737mm)	48”(1219mm)	96”(2438mm)

Upper Top Dimensions

Height	Diameter
36”(914mm)	60”(1524mm)

To Order, Specify:

- 1) Product number, including:

1 Cutout Option:

- N** No Cutout
- L** Cutout - Lower Top, add **\$133.04** list
- P** Cutout - Lower and Upper Top, add **\$266.08** list
- U** Cutout - Upper Top, add **\$133.04** list

- 2) Lower surface finish/color.
- 3) Edge trim color (laminate only).
- 4) Upper surface finish/color.
- 5) Edge trim color (laminate only).
- 6) Understructure trim color. Grade B, add **\$43.26** list.
- 7) Wood leg finish.
 - M7-W43 Ink on Ash - no upcharge
 - M5-W35 Clear on White Oak, add **\$227.75** list
 - M6-W35 Clear on Walnut, add **\$688.39** list
- 8) Stack spacer color.

Overall Width	Number	①	Upper Top		Wood Group A	Group B	Solid Surface
			Laminate Grade A	Grade B			
Paint Grade A Lower Top							
138”(3505mm)	THRD-48D8-TFS	DGAW	\$12679.22	\$12889.06	N/A	N/A	N/A
	THRD-48D8-HUS	DGAW	N/A	N/A	N/A	N/A	\$23165.22
	THRD-48D8-IUS	DGAW	N/A	N/A	\$14149.22	\$14723.22	N/A
Paint Grade B Lower Top							
138”(3505mm)	THRD-48D8-TFS	DGAW	\$12701.93	\$12911.77	N/A	N/A	N/A
	THRD-48D8-HUS	DGAW	N/A	N/A	N/A	N/A	\$23187.93
	THRD-48D8-IUS	DGAW	N/A	N/A	\$14171.93	\$14745.93	N/A
Laminate Grade A Lower Top							
138”(3505mm)	THRD-48D8-LFS	DGAW	\$10759.22	\$10969.06	N/A	N/A	N/A
	THRD-48D8-JFS	DGAW	N/A	N/A	N/A	N/A	\$21245.22
	THRD-48D8-QFS	DGAW	N/A	N/A	\$12803.22	\$12803.22	N/A
Laminate Grade B Lower Top							
138”(3505mm)	THRD-48D8-LFS	DGAW	\$11008.26	\$11218.10	N/A	N/A	N/A
	THRD-48D8-JFS	DGAW	N/A	N/A	N/A	N/A	\$21494.26
	THRD-48D8-QFS	DGAW	N/A	N/A	\$13052.26	\$13052.26	N/A
Solid Surface Lower Top							
138”(3505mm)	THRD-48D8-KFS	DGAW	\$24181.30	\$24391.14	N/A	N/A	N/A
	THRD-48D8-SSS	DGAW	N/A	N/A	N/A	N/A	\$34667.30
	THRD-48D8-EUS	DGAW	N/A	N/A	\$25651.30	\$26225.30	N/A
Wood Group A Lower Top							
138”(3505mm)	THRD-48D8-RFS	DGAW	\$12640.82	\$12850.66	N/A	N/A	N/A
	THRD-48D8-DUS	DGAW	N/A	N/A	N/A	N/A	\$23126.82
	THRD-48D8-WUS	DGAW	N/A	N/A	\$14110.82	\$14684.82	N/A
Wood Group B Lower Top							
138”(3505mm)	THRD-48D8-RFS	DGAW	\$13375.54	\$13585.38	N/A	N/A	N/A
	THRD-48D8-DUS	DGAW	N/A	N/A	N/A	N/A	\$23861.54
	THRD-48D8-WUS	DGAW	N/A	N/A	\$14845.54	\$15419.54	N/A

Immerse — Shift Table

Racetrack/Round – Wood Legs

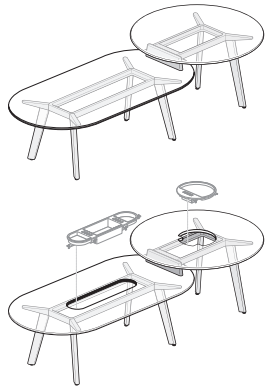

THTD

Features

- Includes racetrack lower top and round upper top, 7”(178mm) high stack spacer, painted understructure, six solid wood legs, adjustable glides and hardware.
- Tops: Racetrack lower top available painted, laminate, solid surface and wood veneer with knife edge. Round upper top available in laminate, solid surface or wood veneer with knife edge. Round upper top not available painted.
 - Painted 1 1/8”(29mm) thick
 - Laminate and wood veneer 1 3/16”(30mm) thick
 - Solid surface 1”(25mm) thick
- Solid surface is standard in Cameo White.
- Stack spacer is painted MDF.
- Glides have 1/2”(13mm) height adjustment and are standard in black.
- Depth and width shown in nominal dimensions.
- Ships unassembled.

Specification Tips

- Separately specified power available. Use Oblong Planter (EHPO-_____) for the racetrack top and Round Planter (EHPR-_____) for the round top.
- When cutout option (-L) is selected, the cutout is on the lower top, option (-P) the cutout is on the lower and upper top and option (-U) the cutout is on the upper top only.
- Overlap of top and bottom surfaces is 17 3/4”(451mm).
- Seating capacity of 8 based upon 27”(686mm) per chair.
- Tops share one understructure and are not designed to be separated.

Lower Top Dimensions

Height	Depth	Width
29”(737mm)	48”(1219mm)	96”(2438mm)

Upper Top Dimensions

Height	Diameter
36”(914mm)	60”(1524mm)

To Order, Specify:

1) Product number, including:

1 Cutout Option:

- N** No Cutout
- L** Cutout - Lower Top, add **\$133.04** list
- P** Cutout - Lower and Upper Top, add **\$266.08** list
- U** Cutout - Upper Top, add **\$133.04** list

- 2) Lower surface finish/color.
- 3) Edge trim color (laminate only).
- 4) Upper surface finish/color.
- 5) Edge trim color (laminate only).
- 6) Understructure trim color. Grade B, add **\$43.26** list.
- 7) Wood leg finish.
 - M7-W43 Ink on Ash - no upcharge
 - M5-W35 Clear on White Oak, add **\$227.75** list
 - M6-W35 Clear on Walnut, add **\$688.39** list
- 8) Stack spacer color.

Overall Width	Number	1	Upper Top		Wood Group A	Group B	Solid Surface
			Laminate Grade A	Grade B			
Paint Grade A Lower Top							
138”(3505mm)	THTD-48D8-TFS	DGAW	\$12679.22	\$12889.06	N/A	N/A	N/A
	THTD-48D8-HUS	DGAW	N/A	N/A	N/A	N/A	\$23165.22
	THTD-48D8-IUS	DGAW	N/A	N/A	\$14149.22	\$14723.22	N/A
Paint Grade B Lower Top							
138”(3505mm)	THTD-48D8-TFS	DGAW	\$12701.93	\$12911.77	N/A	N/A	N/A
	THTD-48D8-HUS	DGAW	N/A	N/A	N/A	N/A	\$23187.93
	THTD-48D8-IUS	DGAW	N/A	N/A	\$14171.93	\$14745.93	N/A
Laminate Grade A Lower Top							
138”(3505mm)	THTD-48D8-LFS	DGAW	\$10759.22	\$10969.06	N/A	N/A	N/A
	THTD-48D8-JFS	DGAW	N/A	N/A	N/A	N/A	\$21245.22
	THTD-48D8-QFS	DGAW	N/A	N/A	\$12803.22	\$12803.22	N/A
Laminate Grade B Lower Top							
138”(3505mm)	THTD-48D8-LFS	DGAW	\$11008.26	\$11218.10	N/A	N/A	N/A
	THTD-48D8-JFS	DGAW	N/A	N/A	N/A	N/A	\$21494.26
	THTD-48D8-QFS	DGAW	N/A	N/A	\$13052.26	\$13052.26	N/A
Solid Surface Lower Top							
138”(3505mm)	THTD-48D8-KFS	DGAW	\$24181.30	\$24391.14	N/A	N/A	N/A
	THTD-48D8-SSS	DGAW	N/A	N/A	N/A	N/A	\$34667.30
	THTD-48D8-EUS	DGAW	N/A	N/A	\$25651.30	\$26225.30	N/A
Wood Group A Lower Top							
138”(3505mm)	THTD-48D8-RFS	DGAW	\$12640.82	\$12850.66	N/A	N/A	N/A
	THTD-48D8-DUS	DGAW	N/A	N/A	N/A	N/A	\$23126.82
	THTD-48D8-WUS	DGAW	N/A	N/A	\$14110.82	\$14684.82	N/A
Wood Group B Lower Top							
138”(3505mm)	THTD-48D8-RFS	DGAW	\$13375.54	\$13585.38	N/A	N/A	N/A
	THTD-48D8-DUS	DGAW	N/A	N/A	N/A	N/A	\$23861.54
	THTD-48D8-WUS	DGAW	N/A	N/A	\$14845.54	\$15419.54	N/A

Immerse — Single Table

Round – Painted Legs

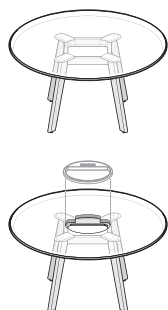

THRN

Features

- Includes top, four painted metal legs, painted understructure, adjustable glides and hardware.
- Tops: Painted, laminate, solid surface or wood veneer with knife edge.
 - Painted 1 1/8”(29mm) thick
 - Laminate and wood veneer 1 3/16”(30mm) thick
 - Solid surface 1”(25mm) thick
- Solid surface is standard in Cameo White.
- Glides have 1/2”(13mm) height adjustment and are standard in black.
- Table height options: 29”(737mm), 36”(914mm) and 39”(991mm).
- Diameter shown in nominal dimensions.
- Ships unassembled.

Specification Tips

- Separately specified power available on the 60”(1524mm) diameter table only. Use Round Planter (EHPR-____).
- 60”(1524mm) diameter table not available painted.

To Order, Specify:

1) Product number, including:

① Surface Option:

- L** Laminate
- P** Painted
- S** Solid Surface
- W** Wood

② Edge Option:

- F** Knife (Laminate)
- U** Knife (Painted or Wood Surface)
- S** Solid Surface (for use with Solid Surface only)

③ Cutout Option:

- N** No Cutout
- P** Cutout, add **\$133.04** list

2) Top surface finish/color.

3) Edge trim color (laminate only).

4) Understructure trim color. Grade B, add **\$43.26** list.5) Trim color. Grade B, add **\$43.26** list.

Height	Diameter	Number ① ② ③	Laminate	Grade B	Paint	Grade B	Wood	Group B	Solid
			Grade A	F	Grade A	U	Group A	U	Surface
29”(737mm)	48”(1219mm)	THRN-4848-■ ■ ■ SNAG4P	\$2793.20	\$2952.64	\$3753.20	\$3775.91	\$3734.00	\$4101.36	\$ 9504.24
	60”(1524mm)	THRN-6060-■ ■ ■ S ■ AG4P	3450.56	3660.40	N/A	N/A	4920.56	5494.56	13936.56
36”(914mm)	48”(1219mm)	THRN-4848-■ ■ ■ SNAG6P	\$2921.93	\$3081.37	\$3881.93	\$3904.64	\$3862.73	\$4230.09	\$ 9632.97
	60”(1524mm)	THRN-6060-■ ■ ■ S ■ AG6P	3579.29	3789.13	N/A	N/A	5049.29	5623.29	14065.29
39”(991mm)	48”(1219mm)	THRN-4848-■ ■ ■ SNAG7P	\$2977.10	\$3136.54	\$3937.10	\$3959.81	\$3917.90	\$4285.26	\$ 9688.14
	60”(1524mm)	THRN-6060-■ ■ ■ S ■ AG7P	3634.46	3844.30	N/A	N/A	5104.46	5678.46	14120.46

Immerse — Single Table

Square – Painted Legs

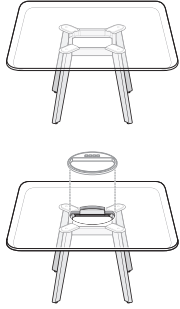

THRQ

Features

- Includes top, four painted metal legs, painted understructure, adjustable glides and hardware.
- Tops: Painted, laminate, solid surface or wood veneer top with knife edge.
 - Painted 1 1/8”(29mm) thick
 - Laminate and wood veneer 1 3/16”(30mm) thick
 - Solid surface 1”(25mm) thick
- Solid surface is standard in Cameo White.
- Glides have 1/2”(13mm) height adjustment and are standard in black.
- Table height options: 29”(737mm), 36”(914mm) and 39”(991mm).
- Depth and width shown in nominal dimensions.
- Ships unassembled.

Specification Tips

- Separately specified power available on the 60”(1524mm) depth table only. Use Round Planter (EHPR-____).
- 60”(1524mm) depth table not available painted.

To Order, Specify:

1) Product number, including:

1 Surface Option:

- L** Laminate
- P** Painted
- S** Solid Surface
- W** Wood

2 Edge Option:

- F** Knife (Laminate)
- U** Knife (Painted or Wood Surface)
- S** Solid Surface (for use with Solid Surface only)

3 Cutout Option:

- N** No Cutout
- P** Cutout, add **\$133.04** list

- 2) Top surface finish/color.
- 3) Edge trim color (laminate only).
- 4) Understructure trim color. Grade B, add **\$43.26** list.
- 5) Trim color. Grade B, add **\$43.26** list.

Height	Depth	Width	Number 1 2 3	Laminate	Paint	Wood	Group B	Solid		
				Grade A	Grade B				Grade A	Group A
				F	F	U	U	S		
29”(737mm)	48”(1219mm)	48”(1219mm)	THRQ-4848-■ ■ SNAG4P	\$2793.20	\$2952.64	\$3753.20	\$3775.91	\$3734.00	\$4101.36	\$ 9504.24
	60”(1524mm)	60”(1524mm)	THRQ-6060-■ ■ S ■ AG4P	3450.56	3660.40	N/A	N/A	4920.56	5494.56	13936.56
36”(914mm)	48”(1219mm)	48”(1219mm)	THRQ-4848-■ ■ SNAG6P	\$2921.93	\$3081.37	\$3881.93	\$3904.64	\$3862.73	\$4230.09	\$ 9632.97
	60”(1524mm)	60”(1524mm)	THRQ-6060-■ ■ S ■ AG6P	3579.29	3789.13	N/A	N/A	5049.29	5623.29	14065.29
39”(991mm)	48”(1219mm)	48”(1219mm)	THRQ-4848-■ ■ SNAG7P	\$2977.10	\$3136.54	\$3937.10	\$3959.81	\$3917.90	\$4285.26	\$ 9688.14
	60”(1524mm)	60”(1524mm)	THRQ-6060-■ ■ S ■ AG7P	3634.46	3844.30	N/A	N/A	5104.46	5678.46	14120.46

Immerse — Single Table

Rectangle – Painted Legs

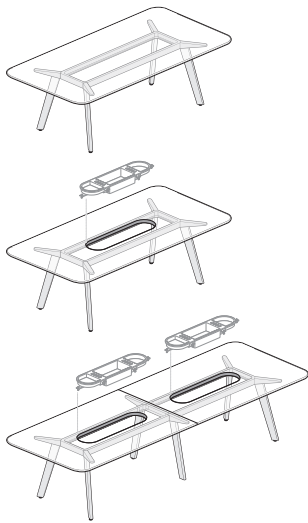

THRA

Features

- Includes top, four painted metal legs, painted understructure, adjustable glides and hardware.
- Tops: Painted, laminate, solid surface or wood veneer top with knife edge.
 - Painted 1 1/8”(29mm) thick
 - Laminate and wood veneer 1 3/16”(30mm) thick
 - Solid surface 1”(25mm) thick
- Solid surface is standard in Cameo White.
- Glides have 1/2”(13mm) height adjustment and are standard in black.
- Table height options: 29”(737mm), 36”(914mm) and 39”(991mm).
- Tops greater than 120”(3048mm) are two piece.
- One piece tops have four legs, two piece tops have 6 legs.
- Depth and width shown in nominal dimensions.
- Ships unassembled.

Specification Tips

- Separately specified power available. Use Oblong Planter (EHPO-____).
- Two piece tops specified with cutout will have two cutouts and require two Oblong Planters.
- 60”(1524mm) depth tables not available painted.

To Order, Specify:

1) Product number, including:

1 Surface Option:

- L** Laminate
- P** Painted
- S** Solid Surface
- W** Wood

2 Edge Option:

- F** Knife (Laminate)
- U** Knife (Painted or Wood Surface)
- S** Solid Surface (for use with Solid Surface only)

3 Cutout Option:

- N** No Cutout
- P** Cutout, add **\$133.04** list for one-piece add **\$266.08** list for two-piece

2) Top surface finish/color.

3) Edge trim color (laminate only).

4) Understructure trim color. Grade B, add **\$43.26** list.

5) Trim color. Grade B, add **\$43.26** list.

Height	Depth	Width	Number ① ② ③	Laminate		Paint		Wood		Solid	
				Grade A F	Grade B F	Grade A U	Grade B U	Group A U	Group B U	Surface S	
29”(737mm)	48”(1219mm)	96”(2438mm)	THRA-4896-■ ■ S AG4P	\$3961.84	\$4210.88	\$5881.84	\$5904.55	\$5843.44	\$ 6578.16	\$17383.92	
	48”(1219mm)	144”(3658mm)	THRA-48E4-■ ■ S AG4P	5130.48	5469.12	N/A	N/A	7952.88	9054.96	25263.60	
	60”(1524mm)	120”(3048mm)	THRA-60CO-■ ■ S AG4P	5276.56	5626.40	N/A	N/A	8216.56	9364.56	26248.56	
	60”(1524mm)	144”(3658mm)	THRA-60E4-■ ■ S AG4P	6006.96	6412.80	N/A	N/A	9534.96	10912.56	31173.36	
36”(914mm)	48”(1219mm)	96”(2438mm)	THRA-4896-■ ■ S AG6P	\$4090.57	\$4339.61	\$6010.57	\$6033.28	\$5972.17	\$ 6706.89	\$17512.65	
	60”(1524mm)	120”(3048mm)	THRA-60CO-■ ■ S AG6P	5405.29	5755.13	N/A	N/A	8345.29	9493.29	26377.29	
39”(991mm)	48”(1219mm)	96”(2438mm)	THRA-4896-■ ■ S AG7P	\$4145.74	\$4394.78	\$6065.74	\$6088.45	\$6027.34	\$ 6762.06	\$17567.82	
	60”(1524mm)	120”(3048mm)	THRA-60CO-■ ■ S AG7P	5460.46	5810.30	N/A	N/A	8400.46	9548.46	26432.46	

Immerse — Single Table

Racetrack – Painted Legs

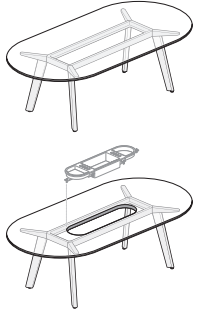

THRT

Features

- Includes top, four painted metal legs, painted understructure, adjustable glides and hardware.
- Tops: Painted, laminate, solid surface or wood veneer top with knife edge.
 - Painted 1 1/8”(29mm) thick
 - Laminate and wood veneer 1 3/16”(30mm) thick
 - Solid surface 1”(25mm) thick
- Solid surface is standard in Cameo White.
- Glides have 1/2”(13mm) height adjustment and are standard in black.
- Table height options: 29”(737mm), 36”(914mm) and 39”(991mm).
- Depth and width shown in nominal dimensions.
- Ships unassembled.

Specification Tip

- Separately specified power available. Use Oblong Planter (EHPO-____).

To Order, Specify:

1) Product number, including:

1 Surface Option:

- L** Laminate
- P** Painted
- S** Solid Surface
- W** Wood

2 Edge Option:

- F** Knife (Laminate)
- U** Knife (Painted or Wood Surface)
- S** Solid Surface (for use with Solid Surface only)

3 Cutout Option:

- N** No Cutout
- P** Cutout, add **\$133.04** list

- 2) Top surface finish/color.
- 3) Edge trim color (laminate only).
- 4) Understructure trim color. Grade B, add **\$43.26** list.
- 5) Trim color. Grade B, add **\$43.26** list.

Height	Depth	Width	Number 1 2 3	Laminate	Grade B	Paint	Grade B	Wood	Group B	Solid
				Grade A	F	Grade A	U	Group A	U	Surface
				F	F	U	U	U	U	S
29”(737mm)	48”(1219mm)	96”(2438mm)	THRT-4896- <input type="checkbox"/> <input type="checkbox"/> <input type="checkbox"/> S AG4P	\$3961.84	\$4210.88	\$5881.84	\$5904.55	\$5843.44	\$6578.16	\$17383.92
36”(914mm)	48”(1219mm)	96”(2438mm)	THRT-4896- <input type="checkbox"/> <input type="checkbox"/> <input type="checkbox"/> S AG6P	\$4090.57	\$4339.61	\$6010.57	\$6033.28	\$5972.17	\$6706.89	\$17512.65
39”(991mm)	48”(1219mm)	96”(2438mm)	THRT-4896- <input type="checkbox"/> <input type="checkbox"/> <input type="checkbox"/> S AG7P	\$4145.74	\$4394.78	\$6065.74	\$6088.45	\$6027.34	\$6762.06	\$17567.82

Immerse — Single Table

Round – Wood Legs

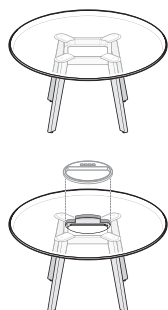

THRN

Features

- Includes top, four solid wood legs, painted understructure, adjustable glides and hardware.
- Tops: Painted, laminate, solid surface or wood veneer with knife edge.
 - Painted 1 1/8”(29mm) thick
 - Laminate and wood veneer 1 3/16”(30mm) thick
 - Solid surface 1”(25mm) thick
- Solid surface is standard in Cameo White.
- Glides have 1/2”(13mm) height adjustment and are standard in black.
- Table height options: 29”(737mm), 36”(914mm) and 39”(991mm).
- Diameter shown in nominal dimensions.
- Ships unassembled.

Specification Tips

- Separately specified power available on the 60”(1524mm) diameter table only. Use Round Planter (EHPR-____).
- 60”(1524mm) diameter table not available painted.

To Order, Specify:

1) Product number, including:

1 Surface Option:

- L** Laminate
- P** Painted
- S** Solid Surface
- W** Wood

2 Edge Option:

- F** Knife (Laminate)
- U** Knife (Painted or Wood Surface)
- S** Solid Surface (for use with Solid Surface only)

3 Cutout Option:

- N** No Cutout
- P** Cutout, add **\$133.04** list

2) Top surface finish/color.

3) Edge trim color (laminate only).

4) Understructure trim color. Grade B, add **\$43.26** list.

5) Wood leg finish.

M7-W43 Ink on Ash - no upcharge

M5-W35 Clear on White Oak, add **\$147.09** listM6-W35 Clear on Walnut, add **\$444.57** list

Height	Diameter	Number 1 2 3	Laminate	Grade B	Paint	Grade B	Wood	Group B	Solid
			Grade A F	F	Grade A U	U	Group A U	U	Surface S
29”(737mm)	48”(1219mm)	THRN-4848- <input type="checkbox"/> <input type="checkbox"/> SNAG4W	\$5186.78	\$5346.22	\$6146.78	\$6169.49	\$6127.58	\$6494.94	\$11897.82
	60”(1524mm)	THRN-6060- <input type="checkbox"/> <input type="checkbox"/> S <input type="checkbox"/> AG4W	5844.14	6053.98	N/A	N/A	7314.14	7888.14	16330.14
36”(914mm)	48”(1219mm)	THRN-4848- <input type="checkbox"/> <input type="checkbox"/> SNAG6W	\$5315.51	\$5474.95	\$6275.51	\$6298.22	\$6256.31	\$6623.67	\$12026.55
	60”(1524mm)	THRN-6060- <input type="checkbox"/> <input type="checkbox"/> S <input type="checkbox"/> AG6W	5972.87	6182.71	N/A	N/A	7442.87	8016.87	16458.87
39”(991mm)	48”(1219mm)	THRN-4848- <input type="checkbox"/> <input type="checkbox"/> SNAG7W	\$5370.68	\$5530.12	\$6330.68	\$6353.39	\$6311.48	\$6678.84	\$12081.72
	60”(1524mm)	THRN-6060- <input type="checkbox"/> <input type="checkbox"/> S <input type="checkbox"/> AG7W	6028.04	6237.88	N/A	N/A	7498.04	8072.04	16514.04

Immerse — Single Table

Square – Wood Legs

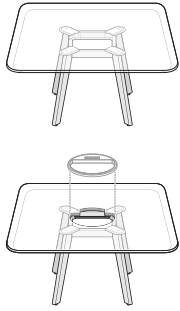

THRQ

Features

- Includes top, four solid wood legs, painted understructure, adjustable glides and hardware.
- Tops: Painted, laminate, solid surface or wood veneer top with knife edge.
 - Painted 1 1/8”(29mm) thick
 - Laminate and wood veneer 1 3/16”(30mm) thick
 - Solid surface 1”(25mm) thick
- Solid surface is standard in Cameo White.
- Glides have 1/2”(13mm) height adjustment and are standard in black.
- Table height options: 29”(737mm), 36”(914mm) and 39”(991mm).
- Depth and width shown in nominal dimensions.
- Ships unassembled.

Specification Tips

- Separately specified power available on the 60”(1524mm) depth table only. Use Round Planter (EHPR-____).
- 60”(1524mm) depth table not available painted.

To Order, Specify:

1) Product number, including:

1 Surface Option:

- L** Laminate
- P** Painted
- S** Solid Surface
- W** Wood

2 Edge Option:

- F** Knife (Laminate)
- U** Knife (Painted or Wood Surface)
- S** Solid Surface (for use with Solid Surface only)

3 Cutout Option:

- N** No Cutout
- P** Cutout, add **\$133.04** list

2) Top surface finish/color.

3) Edge trim color (laminate only).

4) Understructure trim color. Grade B, add **\$43.26** list.

5) Wood leg finish.

M7-W43 Ink on Ash - no upcharge

M5-W35 Clear on White Oak, add **\$147.09** list

M6-W35 Clear on Walnut, add **\$444.57** list

Height	Depth	Width	Number 1 2 3	Laminate	Paint	Wood	Group B		Solid	
				Grade A F	Grade B F	Grade A U	Grade B U	Group A U	Group B U	Surface S
29”(737mm)	48”(1219mm)	48”(1219mm)	THRQ-4848-■ ■ SNAG4W	\$5186.78	\$5346.22	\$6146.78	\$6169.49	\$6127.58	\$6494.94	\$11897.82
	60”(1524mm)	60”(1524mm)	THRQ-6060-■ ■ S ■ AG4W	5844.14	6053.98	N/A	N/A	7314.14	7888.14	16330.14
36”(914mm)	48”(1219mm)	48”(1219mm)	THRQ-4848-■ ■ SNAG6W	\$5315.51	\$5474.95	\$6275.51	\$6298.22	\$6256.31	\$6623.67	\$12026.55
	60”(1524mm)	60”(1524mm)	THRQ-6060-■ ■ S ■ AG6W	5972.87	6182.71	N/A	N/A	7442.87	8016.87	16458.87
39”(991mm)	48”(1219mm)	48”(1219mm)	THRQ-4848-■ ■ SNAG7W	\$5370.68	\$5530.12	\$6330.68	\$6353.39	\$6311.48	\$6678.84	\$12081.72
	60”(1524mm)	60”(1524mm)	THRQ-6060-■ ■ S ■ AG7W	6028.04	6237.88	N/A	N/A	7498.04	8072.04	16514.04

Immerse — Single Table

Rectangle – Wood Legs

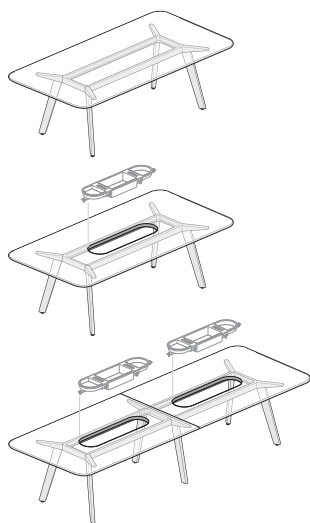

THRA

Features

- Includes top, four solid wood legs, painted understructure, adjustable glides and hardware.
- Tops: Painted, laminate, solid surface or wood veneer top with knife edge.
 - Painted 1 1/8”(29mm) thick
 - Laminate and wood veneer 1 3/16”(30mm) thick
 - Solid surface 1”(25mm) thick
- Solid surface is standard in Cameo White.
- Glides have 1/2”(13mm) height adjustment and are standard in black.
- Table height options: 29”(737mm), 36”(914mm) and 39”(991mm).
- Tops greater than 120”(3048mm) are two piece.
- One piece tops have four legs, two piece tops have 6 legs.
- Depth and width shown in nominal dimensions.
- Ships unassembled.

Specification Tips

- Separately specified power available. Use Oblong Planter (EHPO-____).
- Two piece tops specified with cutout will have two cutouts and require two Oblong Planters.
- 60”(1524mm) depth tables not available painted.

To Order, Specify:

1) Product number, including:

1 Surface Option:

- L** Laminate
- P** Painted
- S** Solid Surface
- W** Wood

2 Edge Option:

- F** Knife (Laminate)
- U** Knife (Painted or Wood Surface)
- S** Solid Surface (for use with Solid Surface only)

3 Cutout Option:

- N** No Cutout
- P** Cutout, add **\$133.04** list for one-piece add **\$266.08** list for two-piece

2) Top surface finish/color.

3) Edge trim color (laminate only).

4) Understructure trim color. Grade B, add **\$43.26** list.

5) Wood leg finish.

M7-W43 Ink on Ash - no upcharge

M5-W35 Clear on White Oak, add **\$147.09** list

M6-W35 Clear on Walnut, add **\$444.57** list

Height	Depth	Width	Number	① ② ③			Laminate	Grade B	Paint	Grade B	Wood	Group B	Solid	
				F	F	U	U	U	U	S				
29”(737mm)	48”(1219mm)	96”(2438mm)	THRA-4896-	■	■	S	AG4W	\$6355.42	\$6604.46	\$8275.42	\$8298.13	\$ 8237.02	\$ 8971.74	\$19777.50
	48”(1219mm)	144”(3658mm)	THRA-48E4-	■	■	S	AG4W	7524.06	7862.70	N/A	N/A	10346.46	11448.54	27657.18
	60”(1524mm)	120”(3048mm)	THRA-60C0-	■	■	S	AG4W	7670.14	8019.98	N/A	N/A	10610.14	11758.14	28642.14
	60”(1524mm)	144”(3658mm)	THRA-60E4-	■	■	S	AG4W	8400.54	8806.38	N/A	N/A	11928.54	13306.14	33566.94
36”(914mm)	48”(1219mm)	96”(2438mm)	THRA-4896-	■	■	S	AG6W	\$6484.15	\$6733.19	\$8404.15	\$8426.86	\$ 8365.75	\$ 9100.47	\$19906.23
	60”(1524mm)	120”(3048mm)	THRA-60C0-	■	■	S	AG6W	7798.87	8148.71	N/A	N/A	10738.87	11886.87	28770.87
39”(991mm)	48”(1219mm)	96”(2438mm)	THRA-4896-	■	■	S	AG7W	\$6539.32	\$6788.36	\$8459.32	\$8482.03	\$ 8420.92	\$ 9155.64	\$19961.40
	60”(1524mm)	120”(3048mm)	THRA-60C0-	■	■	S	AG7W	7854.04	8203.88	N/A	N/A	10794.04	11942.04	28826.04

Immerse — Single Table

Racetrack – Wood Legs

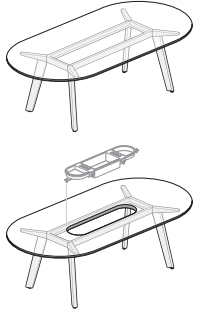

THRT

Features

- Includes top, four solid wood legs, painted understructure, adjustable glides and hardware.
- Tops: Painted, laminate, solid surface or wood veneer top with knife edge.
 - Painted 1 1/8”(29mm) thick
 - Laminate and wood veneer 1 3/16”(30mm) thick
 - Solid surface 1”(25mm) thick
- Solid surface is standard in Cameo White.
- Glides have 1/2”(13mm) height adjustment and are standard in black.
- Table height options: 29”(737mm), 36”(914mm) and 39”(991mm).
- Depth and width shown in nominal dimensions.
- Ships unassembled.

Specification Tip

- Separately specified power available. Use Oblong Planter (EHPO-____).

To Order, Specify:

1) Product number, including:

1 Surface Option:

- L** Laminate
- P** Painted
- S** Solid Surface
- W** Wood

2 Edge Option:

- F** Knife (Laminate)
- U** Knife (Painted or Wood Surface)
- S** Solid Surface (for use with Solid Surface only)

3 Cutout Option:

- N** No Cutout
- P** Cutout, add **\$133.04** list

2) Top surface finish/color.

3) Edge trim color (laminate only).

4) Understructure trim color. Grade B, add **\$43.26** list.

5) Wood leg finish.

M7-W43 Ink on Ash - no upcharge

M5-W35 Clear on White Oak, add **\$147.09** list

M6-W35 Clear on Walnut, add **\$444.57** list

Height	Depth	Width	Number 1 2 3	Laminate	Paint	Wood	Group B	Group B	Solid	
				Grade A F	Grade B F	Grade A U				Grade B U
29”(737mm)	48”(1219mm)	96”(2438mm)	THRT-4896-■ ■ S ■ AG4W	\$6355.42	\$6604.46	\$8275.42	\$8298.13	\$8237.02	\$8971.74	\$19777.50
36”(914mm)	48”(1219mm)	96”(2438mm)	THRT-4896-■ ■ S ■ AG6W	\$6484.15	\$6733.19	\$8404.15	\$8426.86	\$8365.75	\$9100.47	\$19906.23
39”(991mm)	48”(1219mm)	96”(2438mm)	THRT-4896-■ ■ S ■ AG7W	\$6539.32	\$6788.36	\$8459.32	\$8482.03	\$8420.92	\$9155.64	\$19961.40

Immerse — Stack Table

Rectangle – Painted Legs

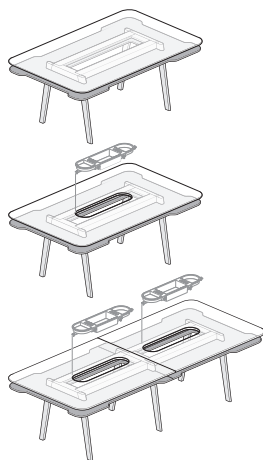

THRA

Features

- Includes top, 1/8”(3mm) thick sill (below surface), painted metal legs, painted understructure, adjustable glides and hardware.
- Top (upper surface), laminate, solid surface or wood veneer with knife edge.
 - Laminate and wood veneer 1 3/16”(30mm) thick
 - Solid surface 1”(25mm) thick
- Sill is solid surface with flat edge or laminate.
- Solid surface is standard in Cameo White.
- Glides have 1/2”(13mm) height adjustment and are standard in black.
- Tops greater than 120”(3048mm) are two piece.
- One piece tops have four legs, two piece tops have 6 legs.
- Depth and width shown in nominal dimensions.
- Ships unassembled.

Specification Tips

- Separately specified power available. Use Oblong Planter (EHPO-____).
- When cutout option (-P) is selected, single piece table has one cutout and two piece tables has two cutouts. Order the correct number of planters.
- Stack table not available painted.

To Order, Specify:

1) Product number, including:

1 Surface Option:

- L** Laminate
- S** Solid Surface
- W** Wood

2 Edge Option:

- F** Knife (Laminate)
- U** Knife (Wood Surface)
- S** Solid Surface (for use with Solid Surface only)

3 Cutout Option:

- N** No Cutout
- P** Cutout, add **\$133.04** list for one-piece add **\$266.08** list for two-piece

- 2) Top surface finish/color.
- 3) Edge trim color (laminate only).
- 4) Sill surface color.
- 5) Sill edge trim color (laminate only).
- 6) Understructure trim color. Grade B, add **\$43.26** list.
- 7) Trim color. Grade B, add **\$43.26** list.

Height	Depth	Width	Number 1 2 3	Laminate	Grade B	Wood	Group B	Solid
				Grade A	F	Group A	U	Surface
39”(991mm)	60”(1524mm)	96”(2438mm)	THRA-6096- S CG7P	\$ 8112.66	\$ 8404.90	\$15381.46	\$16299.86	\$29807.06
39”(991mm)	60”(1524mm)	120”(3048mm)	THRA-60C0- S CG7P	11121.01	11468.85	20207.01	21355.01	38239.01
39”(991mm)	60”(1524mm)	144”(3658mm)	THRA-60E4- S CG7P	12703.81	13107.25	23607.01	24984.61	45245.41

Immerse — Planter — Oblong

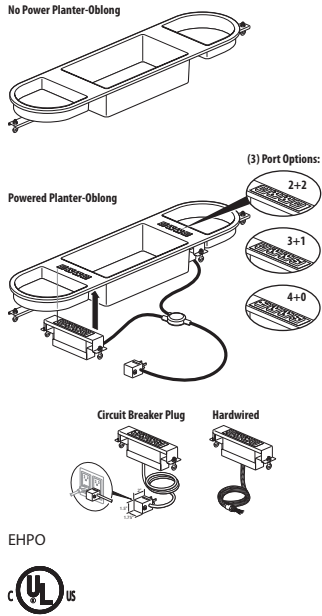

Features

- Includes planter, brackets, and mounting hardware.
- Available in Black, Smooth Plaster, Gray Tone, and Terra Cotta.
- Available with or without power.
- When ordering with power option:
 - Includes 2 power modules with a total of 8 ports that can be configured with simplex outlets (NEMA-5-15R), or USB charging simplex outlets (with 2 USB outlets). No data or cable bay options are available.
 - Includes cable management clips.
- Corded option combines both power modules into a single NEMA-5-15P style circuit breaker plug.
- Power modules are UL listed.

To Order, Specify:

- 1) Product number.
- 2) Trim finish.

Specification Tips

- The no power option cannot be modified for power in the field.
- Specify the power and USB port options (1 configuration for both power modules).
- Power modules are color matched to the planter.
- Installs in a factory cut work surface.
- Planter, brackets, and power modules are field installed. Hand tighten mounting hardware to avoid deformation of the planter.
- For use with 120 volt, 60 hertz power source only.
- Application may require approval of local authority having jurisdiction (AHJ); ensure compliance before placing orders and installation.

Width	Bezel Depth	Cord Length	Port	Configuration (per side)	Number	Price
No Power						
					EHPO-000M-00	\$ 705.21
Corded						
		6'(1829mm)	8	4 Power Receptacles	EHPO-PF0M-40	\$1667.83
				3 Power Receptacles, 1 USB Charging	EHPO-PF0M-31	1732.73
				2 Power Receptacles, 2 USB Charging	EHPO-PF0M-22	1797.63
		12'(3658mm)	8	4 Power Receptacles	EHPO-PL0M-40	\$1720.83
				3 Power Receptacles, 1 USB Charging	EHPO-PL0M-31	1785.73
				2 Power Receptacles, 2 USB Charging	EHPO-PL0M-22	1850.63
		21'(6401mm)	8	4 Power Receptacles	EHPO-PW0M-40	\$1773.83
				3 Power Receptacles, 1 USB Charging	EHPO-PW0M-31	1838.73
				2 Power Receptacles, 2 USB Charging	EHPO-PW0M-22	1903.63
Hardwire						
		6'(1829mm)	8	4 Power Receptacles	EHPO-HF0M-40	\$1812.76
				3 Power Receptacles, 1 USB Charging	EHPO-HF0M-31	1877.66
				2 Power Receptacles, 2 USB Charging	EHPO-HF0M-22	1942.56
		12'(3658mm)	8	4 Power Receptacles	EHPO-HL0M-40	\$1865.76
				3 Power Receptacles, 1 USB Charging	EHPO-HL0M-31	1930.66
				2 Power Receptacles, 2 USB Charging	EHPO-HL0M-22	1995.56

Immerse — Planter — Round

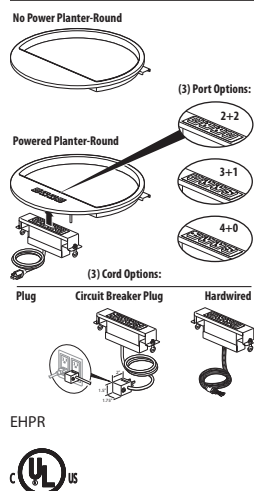
**Features**

- Includes planter, brackets, and mounting hardware.
- Available in Black, Smooth Plaster, Gray Tone, and Terra Cotta.
- Available with and without power.
- When ordering with power option:
 - Includes a power module with a total of 4 ports that can be configured with simplex outlets (NEMA-5-15R), or USB charging simplex outlets (with 2 USB outlets). No data or cable bay options are available.
- Power module is UL listed.

Specification Tips

- The no power option cannot be modified for power in the field.
- **Choosing 4 power ports and 0 USB requires the use of a NEMA-5-15P style circuit breaker plug.**
- Power modules are color matched to the planter.
- Installs in a factory cut work surface.
- Planter, brackets, and power modules are field installed. Hand tighten mounting hardware to avoid deformation of the planter.
- For use with 120 volt, 60 hertz power source only.
- Application may require approval of local authority having jurisdiction (AHJ); ensure compliance before placing orders and installation.

To Order, Specify:

- 1) Product number.
- 2) Trim finish.

Width	Bezel Depth	Cord Length	Port	Configuration	Number	Price
No Power						
					EHPR-000M-00	\$ 578.66
Corded						
		6'(1829mm)	4	4 Power Receptacles	EHPR-PF0M-40	\$1240.60
				3 Power Receptacles, 1 USB Charging	EHPR-PF0M-31	1305.50
				2 Power Receptacles, 2 USB Charging	EHPR-PF0M-22	1370.40
		12'(3658mm)	4	4 Power Receptacles	EHPR-PL0M-40	\$1293.60
				3 Power Receptacles, 1 USB Charging	EHPR-PL0M-31	1358.50
				2 Power Receptacles, 2 USB Charging	EHPR-PL0M-22	1423.40
		21'(6401mm)	4	4 Power Receptacles	EHPR-PW0M-40	\$1346.60
				3 Power Receptacles, 1 USB Charging	EHPR-PW0M-31	1411.50
				2 Power Receptacles, 2 USB Charging	EHPR-PW0M-22	1476.40
Hardwire						
		6'(1829mm)	4	4 Power Receptacles	EHPR-HF0M-40	\$1385.53
				3 Power Receptacles, 1 USB Charging	EHPR-HF0M-31	1450.43
				2 Power Receptacles, 2 USB Charging	EHPR-HF0M-22	1515.33
		12'(3658mm)	4	4 Power Receptacles	EHPR-HL0M-40	\$1438.53
				3 Power Receptacles, 1 USB Charging	EHPR-HL0M-31	1503.43
				2 Power Receptacles, 2 USB Charging	EHPR-HL0M-22	1568.33

This page intentionally blank

Improv Series

This page intentionally blank

Improv Series Occasional Tables

Height	Table Top/Edge	Number	Laminate		Wood Surface
			A	B	
16"(406mm)	Laminate/Chamfered Hardwood	MTR2-20-1	\$805.25	\$882.59	N/A
Wood only	Wood/Chamfered Hardwood	MTR3-20-1	N/A	N/A	\$828.72
20"(508mm)	Laminate/Chamfered Hardwood	MTR2-20-2	\$805.25	\$882.59	N/A
Wood only	Wood/Chamfered Hardwood	MTR3-20-2	N/A	N/A	\$828.72

Round Table



MTR1-20

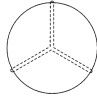

(top view)

Features

- Table top diameter is 20"(508mm).
- Oval steel tube legs with color-matched high-density polyethylene floor glides and leg polypropylene caps except when ordering Metallic trim; molded components are available in black or smoke and must be specified.
- Shipped fully assembled.

NOTE: Due to the differences in the material properties, the MDF edge will display a darker stain in comparison with the veneer surface.

To Order, Specify:

- 1) Product number.
- 2) Laminate or wood surface color.
- 3) PVC or hardwood edge finish color. (Laminate table tops only.)
- 4) Frame trim color.
- 5) Glides and leg caps for metallic frame; black or smoke option only.

To order table with Metallic trim color add **M** after seventh digit.

Example: MTR1-20-1M

Table Top Edge Details

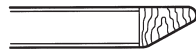

Chamfered Hardwood

This page intentionally blank

Jive

This page intentionally blank

Jive Tables Catalog Logic

Jive Tables

<p>T</p> <hr/>	<p>C</p> <hr/>	<p>RA</p> <hr/>	<p>-</p> <hr/>	<p>24</p> <hr/>	<p>60</p> <hr/>	<p>-</p> <hr/>	<p>L</p> <hr/>	<p>J</p> <hr/>	<p>S</p> <hr/>	<p>J</p> <hr/>	<p>B</p> <hr/>	<p>M</p> <hr/>	<p>4</p> <hr/>	<p>A</p> <hr/>
														<p>Base Foot Finish Option: A – Painted B – Polished</p>
														<p>Height: 1 – 16" 4 – 29" 7 – 42" 2 – 20" 6 – 36"</p>
														<p>Base Foot and Wire Management: <i>Base – No Power</i> C – Casters G – Glides <i>Base – Power Ready</i> J – Casters K – Glides <i>Base – No Power – Flip Top</i> H – Casters F – Glides <i>Base – Power Ready – Flip Top</i> L – Casters M – Glides</p>
														<p>Base Type: B – C-Leg Round G – Bridge C – C-Leg Extruded R – Swivel D – Disc T – T-Leg Extruded E – Post Extruded V – Post Round F – T-Leg Round X – X Base</p>
														<p>Cutout: N – No Cutout Q – Center, Double-Sided/12 outlets A – Center, Single-Sided/2 outlets V – Left/Right, Single-Sided/4 outlets F – Center, Single-Sided/4 outlets K – Left/Right, Single-Sided/6 outlets J – Center, Single-Sided/6 outlets R – 3" Round M – Center, Double-Sided/8 outlets</p>
														<p>Core Type: S – Standard</p>
														<p>Edge: F – Laminate Knife U – Wood Knife J – Laminate Edgeband K – Wood Edgeband</p>
														<p>Surface Material: L – Laminate W – Wood</p>
														<p>Width: 18" – 18" 72" – 72" 24" – 24" 84" – 84" 30" – 30" 96" – 96" 36" – 36" A8 – 108" 42" – 42" C0 – 120" 48" – 48" E4 – 144" 54" – 54" J0 – 180" 60" – 60" M6 – 216"</p>
														<p>Depth: 18" – 18" 42" – 42" 24" – 24" 48" – 48" 30" – 30" 54" – 54" 36" – 36" 60" – 60"</p>
														<p>Shape: BN – Crescent RA – Rectangle CE – Extended Corner RN – Round CX – Transitional Extended Corner RP – Pebble HP – Half Pebble RQ – Square HT – Half Race Track RT – Racetrack HX – Half Hexagon TP – Trapezoid</p>
														<p>Product Line: C – Jive</p>

Product Type:
T – Table

Jive Table — Post Extruded Base

Round – Laminate or Wood

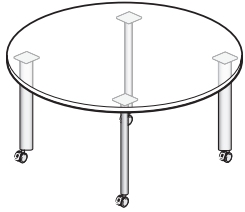

TCRN

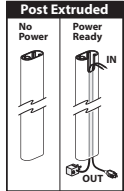

Features

- Includes 1 3/16" (30mm) thick top, leg bases, adjustable glides or casters, and hardware.
- Standard table heights are 16" (406mm), 20" (508mm) and 29" (737mm).
- Laminate top with knife edge or 3mm edgeband edges or wood veneer top with 3mm wood edgeband or knife edge.
- Bases are painted steel.
- 16" (406mm) and 20" (508mm) heights are available with glides only.
- 29" (737mm) height available with glides or casters.
- Casters:
 - Two locking and two non-locking casters with 5/8" (16mm) adjustment.
 - Standard in black.
- Glides:
 - 5/8" (16mm) adjustment.
 - Standard in black.
- Glides have 3/4" (19mm) height adjustment.
- Casters and glides are not interchangeable.
- Depth and width shown in nominal dimensions.
- Ships unassembled.

Specification Tips

- **Specifying a cutout does not automatically include a Power Ready base.**
- Factory installed cutout is available for:
 - Specify the (F) option for a Center, Single-Sided/4 outlet Flip Top Unit
 - Specify the (J) option for a Center, Single-Sided/6 outlet Flip Top Unit
 - Specify the (M) option for a Center, Double-Sided/8 outlet Flip Top Unit
 - Specify the (Q) option for a Center, Double-Sided/12 outlet Flip Top Unit
- Power Ready Base:
 - Allows for cord management through one of the Post Extruded legs.
- **Powered leg location determined during installation.**
 - Casters and Glides:
 - Specify the (J) option for Casters on the Power Ready base (only available on 29" (737mm) high tables)
 - Specify the (K) option for Glides on the Power Ready base (available on 16" (406mm), 20" (508mm) and 29" (737mm) high tables)
 - Flip Top Unit circuit breaker plug fits Power Ready Base opening.
- **Power cord length determines the distance to building power source.**
- Separately specified:
 - Horizontal and Vertical Wire Management
 - Power and Data Components
 - Accessories
- Refer to Specification Guide:
 - Accessory placement and compatibility.
 - Seating capacities and leg locations.
 - Information on electrical components compatible with factory cut opening.
 - Power Ready base cable capacity.
- Application may require approval of local authority having jurisdiction (AHJ); ensure compliance before placing orders and installation.

To Order, Specify:

1) Product number, including:

1 Surface Option:

- L** Laminate
- W** Wood

2 Edge Option:

Laminate:

- J** Edgeband
- F** Knife

Wood:

- K** Edgeband
- U** Knife

3 Cutout:

- N** No Cutout
- F** Center, Single-Sided/4 outlets, add **\$33.13** list
- J** Center, Single-Sided/6 outlets, add **\$33.13** list
- M** Center, Double-Sided/8 outlets, add **\$33.13** list
- Q** Center, Double-Sided/12 outlets, add **\$33.13** list

4 Base and Wire Management Option:

Base - No Power:

- C** Casters, add **\$15.60** list (29" Height Only)
- G** Glides

Base - Power Ready:

- J** Casters, add **\$15.60** list (29" Height Only)
- K** Glides

2) Laminate surface color or wood finish color.

3) Edgeband trim color (laminated only).

4) Base trim color.

Note: **\$41.60** upcharge list for Metallic trim colors.

Jive Table — Post Extruded Base

Round – Laminate or Wood

Height	Depth	Width	Number	①	②	③	④	Laminate A		Laminate B		Wood Group A		Wood Group B		
								J	F	J	F	K	U	K	U	
Base — No Power — No Cutout																
16"(406mm)	24"(610mm)	24"(610mm)	TCRN-2424-	■	■	S	E	1	\$ 491.31	\$ 647.15	\$ 491.31	\$ 647.15	\$ 530.67	\$ 616.69	\$ 543.15	\$ 634.42
	30"(762mm)	30"(762mm)	TCRN-3030-	■	■	S	E	1	543.36	727.76	547.14	731.54	695.70	844.63	738.21	902.61
	36"(914mm)	36"(914mm)	TCRN-3636-	■	■	S	E	1	605.91	818.87	614.31	827.27	894.15	1126.31	972.67	1234.02
	42"(1067mm)	42"(1067mm)	TCRN-4242-	■	■	S	E	1	678.96	920.48	692.82	934.34	1126.02	1462.46	1246.53	1629.51
	48"(1219mm)	48"(1219mm)	TCRN-4848-	■	■	S	E	1	762.51	1032.59	782.67	1052.75	1391.31	1852.21	1559.79	2088.05
20"(508mm)	24"(610mm)	24"(610mm)	TCRN-2424-	■	■	S	E	2	\$ 496.56	\$ 652.40	\$ 496.56	\$ 652.40	\$ 535.92	\$ 621.94	\$ 548.40	\$ 639.67
	30"(762mm)	30"(762mm)	TCRN-3030-	■	■	S	E	2	548.61	733.01	552.39	736.79	700.95	849.88	743.46	907.86
	36"(914mm)	36"(914mm)	TCRN-3636-	■	■	S	E	2	611.16	824.12	619.56	832.52	899.40	1131.56	977.92	1239.27
	42"(1067mm)	42"(1067mm)	TCRN-4242-	■	■	S	E	2	684.21	925.73	698.07	939.59	1131.27	1467.71	1251.78	1634.76
	48"(1219mm)	48"(1219mm)	TCRN-4848-	■	■	S	E	2	767.76	1037.84	787.92	1058.00	1396.56	1857.46	1565.04	2093.30
29"(737mm)	30"(762mm)	30"(762mm)	TCRN-3030-	■	■	S	E	4	\$ 564.37	\$ 748.77	\$ 568.15	\$ 752.55	\$ 716.71	\$ 865.64	\$ 759.22	\$ 923.62
	36"(914mm)	36"(914mm)	TCRN-3636-	■	■	S	E	4	626.92	839.88	635.32	848.28	915.16	1147.32	993.68	1255.03
	42"(1067mm)	42"(1067mm)	TCRN-4242-	■	■	S	E	4	699.97	941.49	713.83	955.35	1147.03	1483.47	1267.54	1650.52
	48"(1219mm)	48"(1219mm)	TCRN-4848-	■	■	S	E	4	783.52	1053.60	803.68	1073.76	1412.32	1873.22	1580.80	2109.06
	54"(1372mm)	54"(1372mm)	TCRN-5454-	■	■	S	E	4	877.57	1176.21	904.87	1203.51	1711.03	2316.98	1933.46	2631.13
	60"(1524mm)	60"(1524mm)	TCRN-6060-	■	■	S	E	4	982.12	1309.32	1017.40	1344.60	2043.16	2815.42	2325.52	3217.52
Base — Power Ready — No Cutout																
16"(406mm)	24"(610mm)	24"(610mm)	TCRN-2424-	■	■	S	E	1	\$ 511.31	\$ 667.15	\$ 511.31	\$ 667.15	\$ 550.67	\$ 636.69	\$ 563.15	\$ 654.42
	30"(762mm)	30"(762mm)	TCRN-3030-	■	■	S	E	1	563.36	747.76	567.14	751.54	715.70	864.63	758.21	922.61
	36"(914mm)	36"(914mm)	TCRN-3636-	■	■	S	E	1	625.91	838.87	634.31	847.27	914.15	1146.31	992.67	1254.02
	42"(1067mm)	42"(1067mm)	TCRN-4242-	■	■	S	E	1	698.96	940.48	712.82	954.34	1146.02	1482.46	1266.53	1649.51
	48"(1219mm)	48"(1219mm)	TCRN-4848-	■	■	S	E	1	782.51	1052.59	802.67	1072.75	1411.31	1872.21	1579.79	2108.05
20"(508mm)	24"(610mm)	24"(610mm)	TCRN-2424-	■	■	S	E	2	\$ 516.56	\$ 672.40	\$ 516.56	\$ 672.40	\$ 555.92	\$ 641.94	\$ 568.40	\$ 659.67
	30"(762mm)	30"(762mm)	TCRN-3030-	■	■	S	E	2	568.61	753.01	572.39	756.79	720.95	869.88	763.46	927.86
	36"(914mm)	36"(914mm)	TCRN-3636-	■	■	S	E	2	631.16	844.12	639.56	852.52	919.40	1151.56	997.92	1259.27
	42"(1067mm)	42"(1067mm)	TCRN-4242-	■	■	S	E	2	704.21	945.73	718.07	959.59	1151.27	1487.71	1271.78	1654.76
	48"(1219mm)	48"(1219mm)	TCRN-4848-	■	■	S	E	2	787.76	1057.84	807.92	1078.00	1416.56	1877.46	1585.04	2113.30
29"(737mm)	30"(762mm)	30"(762mm)	TCRN-3030-	■	■	S	E	4	\$ 584.37	\$ 768.77	\$ 588.15	\$ 772.55	\$ 736.71	\$ 885.64	\$ 779.22	\$ 943.62
	36"(914mm)	36"(914mm)	TCRN-3636-	■	■	S	E	4	646.92	859.88	655.32	868.28	935.16	1167.32	1013.68	1275.03
	42"(1067mm)	42"(1067mm)	TCRN-4242-	■	■	S	E	4	719.97	961.49	733.83	975.35	1167.03	1503.47	1287.54	1670.52
	48"(1219mm)	48"(1219mm)	TCRN-4848-	■	■	S	E	4	803.52	1073.60	823.68	1093.76	1432.32	1893.22	1600.80	2129.06
	54"(1372mm)	54"(1372mm)	TCRN-5454-	■	■	S	E	4	897.57	1196.21	924.87	1223.51	1731.03	2336.98	1953.46	2651.13
	60"(1524mm)	60"(1524mm)	TCRN-6060-	■	■	S	E	4	1002.12	1329.32	1037.40	1364.60	2063.16	2835.42	2345.52	3237.52

Jive Table — Post Extruded Base

Square – Laminate or Wood

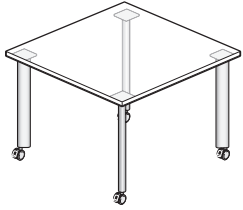

TCRQ

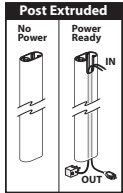

Features

- Includes 1 3/16" (30mm) thick top, leg bases, adjustable glides or casters, and hardware.
- Standard table heights are 16" (406mm), 20" (508mm) and 29" (737mm).
- Laminate top with knife edge or 3mm edgeband edges or wood veneer top with 3mm wood edgeband or knife edge.
- Bases are painted steel.
- 16" (406mm) and 20" (508mm) heights are available with glides only.
- 29" (737mm) height available with glides or casters.
- Casters:
 - Two locking and two non-locking casters with 5/8" (16mm) adjustment.
 - Standard in black.
- Glides:
 - 5/8" (16mm) adjustment.
 - Standard in black.
- Casters and glides are not interchangeable.
- Depth and width shown in nominal dimensions.
- Ships unassembled.

Specification Tips

- Edge choice allows a flat seam between tables.
- **Specifying a cutout does not automatically include a Power Ready base.**
- Factory installed cutout is available for:
 - Specify the (F) option for a Center, Single-Sided/4 outlet Flip Top Unit
 - Specify the (J) option for a Center, Single-Sided/6 outlet Flip Top Unit
 - Specify the (M) option for a Center, Double-Sided/8 outlet Flip Top Unit
 - Specify the (Q) option for a Center, Double-Sided/12 outlet Flip Top Unit
- Power Ready Base:
 - Allows for cord management through one of the Post Extruded legs.
- Powered leg location determined during installation.
 - Casters and Glides:
 - Specify the (J) option for Casters on the Power Ready base (only available on 29" (737mm) high tables)
 - Specify the (K) option for Glides on the Power Ready base (available on 16" (406mm), 20" (508mm) and 29" (737mm) high tables)
 - Flip Top Unit circuit breaker plug fits Power Ready Base opening.
- **Power cord length determines the distance to building power source.**
- Separately specified:
 - Ganging Mechanism - Recommended for use with power between tables.
 - Horizontal and Vertical Wire Management
 - Power and Data Components
 - Accessories
- Refer to Specification Guide:
 - Accessory placement and compatibility.
 - Seating capacities and leg locations.
 - Information on electrical components compatible with factory cut opening.
 - Power Ready base cable capacity.
- Application may require approval of local authority having jurisdiction (AHJ); ensure compliance before placing orders and installation.

To Order, Specify:

1) Product number, including:

1 Surface Option:

- L** Laminate
- W** Wood

2 Edge Option:

Laminate:

- J** Edgeband
- F** Knife

Wood:

- K** Edgeband
- U** Knife

3 Cutout:

- N** No Cutout
- F** Center, Single-Sided/4 outlets, add **\$33.13** list
- J** Center, Single-Sided/6 outlets, add **\$33.13** list
- M** Center, Double-Sided/8 outlets, add **\$33.13** list
- Q** Center, Double-Sided/12 outlets, add **\$33.13** list

4 Base and Wire Management Option:

Base - No Power:

- C** Casters, add **\$15.60** list (29" Height Only)
- G** Glides

Base - Power Ready:

- J** Casters, add **\$15.60** list (29" Height Only)
- K** Glides

2) Laminate surface color or wood finish color.

3) Edgeband trim color (laminate only).

4) Base trim color.

Note: **\$41.60** upcharge list for Metallic trim colors.

Jive Table — Post Extruded Base

Square – Laminate or Wood

Height	Depth	Width	Number	①	②	③	④	Laminate A		Laminate B		Wood Group A		Wood Group B		
								J	F	J	F	K	U	K	U	
Base — No Power — No Cutout																
16"(406mm)	24"(610mm)	24"(610mm)	TCRQ-2424-	■	■	S	E	1	\$ 491.31	\$ 647.15	\$ 491.31	\$ 647.15	\$ 530.67	\$ 616.69	\$ 543.15	\$ 634.42
	30"(762mm)	30"(762mm)	TCRQ-3030-	■	■	S	E	1	543.36	727.76	547.14	731.54	695.70	844.63	738.21	902.61
	36"(914mm)	36"(914mm)	TCRQ-3636-	■	■	S	E	1	605.91	818.87	614.31	827.27	894.15	1126.31	972.67	1234.02
	42"(1067mm)	42"(1067mm)	TCRQ-4242-	■	■	S	E	1	678.96	920.48	692.82	934.34	1126.02	1462.46	1246.53	1629.51
	48"(1219mm)	48"(1219mm)	TCRQ-4848-	■	■	S	E	1	762.51	1032.59	782.67	1052.75	1391.31	1852.21	1559.79	2088.05
20"(508mm)	24"(610mm)	24"(610mm)	TCRQ-2424-	■	■	S	E	2	\$ 496.56	\$ 652.40	\$ 496.56	\$ 652.40	\$ 535.92	\$ 621.94	\$ 548.40	\$ 639.67
	30"(762mm)	30"(762mm)	TCRQ-3030-	■	■	S	E	2	548.61	733.01	552.39	736.79	700.95	849.88	743.46	907.86
	36"(914mm)	36"(914mm)	TCRQ-3636-	■	■	S	E	2	611.16	824.12	619.56	832.52	899.40	1131.56	977.92	1239.27
	42"(1067mm)	42"(1067mm)	TCRQ-4242-	■	■	S	E	2	684.21	925.73	698.07	939.59	1131.27	1467.71	1251.78	1634.76
	48"(1219mm)	48"(1219mm)	TCRQ-4848-	■	■	S	E	2	767.76	1037.84	787.92	1058.00	1396.56	1857.46	1565.04	2093.30
29"(737mm)	30"(762mm)	30"(762mm)	TCRQ-3030-	■	■	S	E	4	\$ 564.37	\$ 748.77	\$ 568.15	\$ 752.55	\$ 716.71	\$ 865.64	\$ 759.22	\$ 923.62
	36"(914mm)	36"(914mm)	TCRQ-3636-	■	■	S	E	4	626.92	839.88	635.32	848.28	915.16	1147.32	993.68	1255.03
	42"(1067mm)	42"(1067mm)	TCRQ-4242-	■	■	S	E	4	699.97	941.49	713.83	955.35	1147.03	1483.47	1267.54	1650.52
	48"(1219mm)	48"(1219mm)	TCRQ-4848-	■	■	S	E	4	783.52	1053.60	803.68	1073.76	1412.32	1873.22	1580.80	2109.06
	54"(1372mm)	54"(1372mm)	TCRQ-5454-	■	■	S	E	4	877.57	1176.21	904.87	1203.51	1711.03	2316.98	1933.46	2631.13
	60"(1524mm)	60"(1524mm)	TCRQ-6060-	■	■	S	E	4	982.12	1309.32	1017.40	1344.60	2043.16	2815.42	2325.52	3217.52
Base — Power Ready — No Cutout																
16"(406mm)	24"(610mm)	24"(610mm)	TCRQ-2424-	■	■	S	E	1	\$ 511.31	\$ 667.15	\$ 511.31	\$ 667.15	\$ 550.67	\$ 636.69	\$ 563.15	\$ 654.42
	30"(762mm)	30"(762mm)	TCRQ-3030-	■	■	S	E	1	563.36	747.76	567.14	751.54	715.70	864.63	758.21	922.61
	36"(914mm)	36"(914mm)	TCRQ-3636-	■	■	S	E	1	625.91	838.87	634.31	847.27	914.15	1146.31	992.67	1254.02
	42"(1067mm)	42"(1067mm)	TCRQ-4242-	■	■	S	E	1	698.96	940.48	712.82	954.34	1146.02	1482.46	1266.53	1649.51
	48"(1219mm)	48"(1219mm)	TCRQ-4848-	■	■	S	E	1	782.51	1052.59	802.67	1072.75	1411.31	1872.21	1579.79	2108.05
20"(508mm)	24"(610mm)	24"(610mm)	TCRQ-2424-	■	■	S	E	2	\$ 516.56	\$ 672.40	\$ 516.56	\$ 672.40	\$ 555.92	\$ 641.94	\$ 568.40	\$ 659.67
	30"(762mm)	30"(762mm)	TCRQ-3030-	■	■	S	E	2	568.61	753.01	572.39	756.79	720.95	869.88	763.46	927.86
	36"(914mm)	36"(914mm)	TCRQ-3636-	■	■	S	E	2	631.16	844.12	639.56	852.52	919.40	1151.56	997.92	1259.27
	42"(1067mm)	42"(1067mm)	TCRQ-4242-	■	■	S	E	2	704.21	945.73	718.07	959.59	1151.27	1487.71	1271.78	1654.76
	48"(1219mm)	48"(1219mm)	TCRQ-4848-	■	■	S	E	2	787.76	1057.84	807.92	1078.00	1416.56	1877.46	1585.04	2113.30
29"(737mm)	30"(762mm)	30"(762mm)	TCRQ-3030-	■	■	S	E	4	\$ 584.37	\$ 768.77	\$ 588.15	\$ 772.55	\$ 736.71	\$ 885.64	\$ 779.22	\$ 943.62
	36"(914mm)	36"(914mm)	TCRQ-3636-	■	■	S	E	4	646.92	859.88	655.32	868.28	935.16	1167.32	1013.68	1275.03
	42"(1067mm)	42"(1067mm)	TCRQ-4242-	■	■	S	E	4	719.97	961.49	733.83	975.35	1167.03	1503.47	1287.54	1670.52
	48"(1219mm)	48"(1219mm)	TCRQ-4848-	■	■	S	E	4	803.52	1073.60	823.68	1093.76	1432.32	1893.22	1600.80	2129.06
	54"(1372mm)	54"(1372mm)	TCRQ-5454-	■	■	S	E	4	897.57	1196.21	924.87	1223.51	1731.03	2336.98	1953.46	2651.13
	60"(1524mm)	60"(1524mm)	TCRQ-6060-	■	■	S	E	4	1002.12	1329.32	1037.40	1364.60	2063.16	2835.42	2345.52	3237.52

This page intentionally blank

Jive Table — Post Extruded Base

Pebble – Laminate or Wood



TCRP-4242 (Symmetrical)



TCRP-3060 (Asymmetrical)

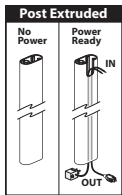

Features

- Includes 1 3/16" (30mm) thick top, leg bases, adjustable glides or casters, and hardware.
- Standard table heights are 16" (406mm), 20" (508mm) and 29" (737mm).
- Laminate top with knife edge or 3mm edgeband edges or wood veneer top with 3mm wood edgeband or knife edge.
- Bases are painted steel.
- 16" (406mm) and 20" (508mm) heights are available with glides only.
- 29" (737mm) height available with glides or casters.
- Casters:
 - Two locking and two non-locking casters with 5/8" (16mm) adjustment.
 - Standard in black.
- Glides:
 - 5/8" (16mm) adjustment.
 - Standard in black.
- Glides have 3/4" (19mm) height adjustment.
- Casters and glides are not interchangeable.
- Depth and width shown in nominal dimensions.
- Ships unassembled.

Specification Tips

- **Specifying a cutout does not automatically include a Power Ready base.**
- Factory installed cutout is available for:
 - Specify the (F) option for a Center, Single-Sided/4 outlet Flip Top Unit
 - Specify the (J) option for a Center, Single-Sided/6 outlet Flip Top Unit
 - Specify the (M) option for a Center, Double-Sided/8 outlet Flip Top Unit
 - Specify the (Q) option for a Center, Double-Sided/12 outlet Flip Top Unit
- Power Ready Base:
 - Allows for cord management through one of the Post Extruded legs.
- **Powered leg location determined during installation.**
 - Casters and Glides:
 - Specify the (J) option for Casters on the Power Ready base (only available on 29" (737mm) high tables)
 - Specify the (K) option for Glides on the Power Ready base (available on 16" (406mm), 20" (508mm) and 29" (737mm) high tables)
 - Flip Top Unit circuit breaker plug fits Power Ready Base opening.
- **Power cord length determines the distance to building power source.**
- Separately specified:
 - Horizontal and Vertical Wire Management
 - Power and Data Components
 - Accessories
- Refer to Specification Guide:
 - Accessory placement and compatibility.
 - Seating capacities and leg locations.
 - Information on electrical components compatible with factory cut opening.
 - Power Ready base cable capacity.
- Application may require approval of local authority having jurisdiction (AHJ); ensure compliance before placing orders and installation.

To Order, Specify:

1) Product number, including:

1 Surface Option:

- L** Laminate
- W** Wood

2 Edge Option:

Laminate:

- J** Edgeband
- F** Knife

Wood:

- K** Edgeband
- U** Knife

3 Cutout:

- N** No Cutout
- F** Center, Single-Sided/4 outlets, add **\$33.13** list
- J** Center, Single-Sided/6 outlets, add **\$33.13** list
- M** Center, Double-Sided/8 outlets, add **\$33.13** list
- Q** Center, Double-Sided/12 outlets, add **\$33.13** list

4 Base and Wire Management Option:

Base - No Power:

- C** Casters, add **\$15.60** list (29" Height Only)
- G** Glides

Base - Power Ready:

- J** Casters, add **\$15.60** list (29" Height Only)
- K** Glides

- 2) Laminate surface color or wood finish color.
- 3) Edgeband trim color (laminate only).
- 4) Base trim color.

Note: **\$41.60** upcharge list for Metallic trim colors.

Jive Table — Post Extruded Base

Pebble – Laminate or Wood

Height	Depth	Width	Number	① ② ③ ④				Laminate A		Laminate B		Wood Group A		Wood Group B	
				J	F	J	F	K	U	K	U				
Symmetrical — Base — No Power — No Cutout															
16"(406mm)	24"(610mm)	24"(610mm)	TCRP-2424-	S	E	1	\$ 491.31	\$ 647.15	\$ 491.31	\$ 647.15	\$ 530.67	\$ 616.69	\$ 543.15	\$ 634.42	
	30"(762mm)	30"(762mm)	TCRP-3030-	S	E	1	543.36	727.76	547.14	731.54	695.70	844.63	738.21	902.61	
	36"(914mm)	36"(914mm)	TCRP-3636-	S	E	1	605.91	818.87	614.31	827.27	894.15	1126.31	972.67	1234.02	
	42"(1067mm)	42"(1067mm)	TCRP-4242-	S	E	1	678.96	920.48	692.82	934.34	1126.02	1462.46	1246.53	1629.51	
	48"(1219mm)	48"(1219mm)	TCRP-4848-	S	E	1	762.51	1032.59	782.67	1052.75	1391.31	1852.21	1559.79	2088.05	
20"(508mm)	24"(610mm)	24"(610mm)	TCRP-2424-	S	E	2	\$ 496.56	\$ 652.40	\$ 496.56	\$ 652.40	\$ 535.92	\$ 621.94	\$ 548.40	\$ 639.67	
	30"(762mm)	30"(762mm)	TCRP-3030-	S	E	2	548.61	733.01	552.39	736.79	700.95	849.88	743.46	907.86	
	36"(914mm)	36"(914mm)	TCRP-3636-	S	E	2	611.16	824.12	619.56	832.52	899.40	1131.56	977.92	1239.27	
	42"(1067mm)	42"(1067mm)	TCRP-4242-	S	E	2	684.21	925.73	698.07	939.59	1131.27	1467.71	1251.78	1634.76	
	48"(1219mm)	48"(1219mm)	TCRP-4848-	S	E	2	767.76	1037.84	787.92	1058.00	1396.56	1857.46	1565.04	2093.30	
29"(737mm)	30"(762mm)	30"(762mm)	TCRP-3030-	S	E	4	\$ 564.37	\$ 748.77	\$ 568.15	\$ 752.55	\$ 716.71	\$ 865.64	\$ 759.22	\$ 923.62	
	36"(914mm)	36"(914mm)	TCRP-3636-	S	E	4	626.92	839.88	635.32	848.28	915.16	1147.32	993.68	1255.03	
	42"(1067mm)	42"(1067mm)	TCRP-4242-	S	E	4	699.97	941.49	713.83	955.35	1147.03	1483.47	1267.54	1650.52	
	48"(1219mm)	48"(1219mm)	TCRP-4848-	S	E	4	783.52	1053.60	803.68	1073.76	1412.32	1873.22	1580.80	2109.06	
	54"(1372mm)	54"(1372mm)	TCRP-5454-	S	E	4	877.57	1176.21	904.87	1203.51	1711.03	2316.98	1933.46	2631.13	
	60"(1524mm)	60"(1524mm)	TCRP-6060-	S	E	4	982.12	1309.32	1017.40	1344.60	2043.16	2815.42	2325.52	3217.52	
Symmetrical — Base — Power Ready — No Cutout															
16"(406mm)	24"(610mm)	24"(610mm)	TCRP-2424-	S	E	1	\$ 511.31	\$ 667.15	\$ 511.31	\$ 667.15	\$ 550.67	\$ 636.69	\$ 563.15	\$ 654.42	
	30"(762mm)	30"(762mm)	TCRP-3030-	S	E	1	563.36	747.76	567.14	751.54	715.70	864.63	758.21	922.61	
	36"(914mm)	36"(914mm)	TCRP-3636-	S	E	1	625.91	838.87	634.31	847.27	914.15	1146.31	992.67	1254.02	
	42"(1067mm)	42"(1067mm)	TCRP-4242-	S	E	1	698.96	940.48	712.82	954.34	1146.02	1482.46	1266.53	1649.51	
	48"(1219mm)	48"(1219mm)	TCRP-4848-	S	E	1	782.51	1052.59	802.67	1072.75	1411.31	1872.21	1579.79	2108.05	
20"(508mm)	24"(610mm)	24"(610mm)	TCRP-2424-	S	E	2	\$ 516.56	\$ 672.40	\$ 516.56	\$ 672.40	\$ 555.92	\$ 641.94	\$ 568.40	\$ 659.67	
	30"(762mm)	30"(762mm)	TCRP-3030-	S	E	2	568.61	753.01	572.39	756.79	720.95	869.88	763.46	927.86	
	36"(914mm)	36"(914mm)	TCRP-3636-	S	E	2	631.16	844.12	639.56	852.52	919.40	1151.56	997.92	1259.27	
	42"(1067mm)	42"(1067mm)	TCRP-4242-	S	E	2	704.21	945.73	718.07	959.59	1151.27	1487.71	1271.78	1654.76	
	48"(1219mm)	48"(1219mm)	TCRP-4848-	S	E	2	787.76	1057.84	807.92	1078.00	1416.56	1877.46	1585.04	2113.30	
29"(737mm)	30"(762mm)	30"(762mm)	TCRP-3030-	S	E	4	\$ 584.37	\$ 768.77	\$ 588.15	\$ 772.55	\$ 736.71	\$ 885.64	\$ 779.22	\$ 943.62	
	36"(914mm)	36"(914mm)	TCRP-3636-	S	E	4	646.92	859.88	655.32	868.28	935.16	1167.32	1013.68	1275.03	
	42"(1067mm)	42"(1067mm)	TCRP-4242-	S	E	4	719.97	961.49	733.83	975.35	1167.03	1503.47	1287.54	1670.52	
	48"(1219mm)	48"(1219mm)	TCRP-4848-	S	E	4	803.52	1073.60	823.68	1093.76	1432.32	1893.22	1600.80	2129.06	
	54"(1372mm)	54"(1372mm)	TCRP-5454-	S	E	4	897.57	1196.21	924.87	1223.51	1731.03	2336.98	1953.46	2651.13	
	60"(1524mm)	60"(1524mm)	TCRP-6060-	S	E	4	1002.12	1329.32	1037.40	1364.60	2063.16	2835.42	2345.52	3237.52	

Jive Table — Post Extruded Base

Pebble – Laminate or Wood

Height	Depth	Width	Number	①	②	③	④	Laminate A		Laminate B		Wood Group A		Wood Group B		
								J	F	J	F	K	U	K	U	
Asymmetrical — Base — No Power — No Cutout																
16"(406mm)	30"(762mm)	48"(1219mm)	TCRP-3048-	■	■	S	E	1	\$619.24	\$ 833.12	\$ 697.48	\$ 911.36	\$1294.70	\$1559.24	\$1451.64	\$1750.93
		60"(1524mm)	TCRP-3060-	■	■	S	E	1	678.79	934.59	761.23	1017.03	1483.29	1802.09	1674.71	2036.71
		72"(1829mm)	TCRP-3072-	■	■	S	E	1	739.03	1040.87	825.67	1127.51	1673.99	2052.37	1900.34	2331.20
	36"(914mm)	60"(1524mm)	TCRP-3660-	■	■	S	E	1	\$733.69	\$1003.77	\$ 820.33	\$1090.41	\$1657.71	\$1994.99	\$1880.59	\$2263.95
72"(1829mm)		TCRP-3672-	■	■	S	E	1	804.60	1121.75	896.28	1213.43	1882.36	2280.55	2146.26	2600.02	
20"(508mm)	30"(762mm)	48"(1219mm)	TCRP-3048-	■	■	S	E	2	\$624.49	\$ 838.37	\$ 702.73	\$ 916.61	\$1299.95	\$1564.49	\$1456.89	\$1756.18
		60"(1524mm)	TCRP-3060-	■	■	S	E	2	684.04	939.84	766.48	1022.28	1488.54	1807.34	1679.96	2041.96
		72"(1829mm)	TCRP-3072-	■	■	S	E	2	744.28	1046.12	830.92	1132.76	1679.24	2057.62	1905.59	2336.45
	36"(914mm)	60"(1524mm)	TCRP-3660-	■	■	S	E	2	\$738.94	\$1009.02	\$ 825.58	\$1095.66	\$1662.96	\$2000.24	\$1885.84	\$2269.20
72"(1829mm)		TCRP-3672-	■	■	S	E	2	809.85	1127.00	901.53	1218.68	1887.61	2285.80	2151.51	2605.27	
29"(737mm)	30"(762mm)	48"(1219mm)	TCRP-3048-	■	■	S	E	4	\$640.25	\$ 854.13	\$ 718.49	\$ 932.37	\$1315.71	\$1580.25	\$1472.65	\$1771.94
		60"(1524mm)	TCRP-3060-	■	■	S	E	4	699.80	955.60	782.24	1038.04	1504.30	1823.10	1695.72	2057.72
		72"(1829mm)	TCRP-3072-	■	■	S	E	4	760.04	1061.88	846.68	1148.52	1695.00	2073.38	1921.35	2352.21
	36"(914mm)	60"(1524mm)	TCRP-3660-	■	■	S	E	4	\$754.70	\$1024.78	\$ 841.34	\$1111.42	\$1678.72	\$2016.00	\$1901.60	\$2284.96
72"(1829mm)		TCRP-3672-	■	■	S	E	4	825.61	1142.76	917.29	1234.44	1903.37	2301.56	2167.27	2621.03	
42"(1067mm)	72"(1829mm)	TCRP-4272-	■	■	S	E	4	\$891.18	\$1223.64	\$ 987.90	\$1320.36	\$2111.73	\$2529.73	\$2413.19	\$2889.85	
		TCRP-4872-	■	■	S	E	4	\$956.76	\$1304.52	\$1058.52	\$1406.28	\$2320.10	\$2757.91	\$2659.11	\$3158.67	
Asymmetrical — Base — Power Ready — No Cutout																
16"(406mm)	30"(762mm)	48"(1219mm)	TCRP-3048-	■	■	S	E	1	\$639.24	\$ 853.12	\$ 717.48	\$ 931.36	\$1314.70	\$1579.24	\$1471.64	\$1770.93
		60"(1524mm)	TCRP-3060-	■	■	S	E	1	698.79	954.59	781.23	1037.03	1503.29	1822.09	1694.71	2056.71
		72"(1829mm)	TCRP-3072-	■	■	S	E	1	759.03	1060.87	845.67	1147.51	1693.99	2072.37	1920.34	2351.20
	36"(914mm)	60"(1524mm)	TCRP-3660-	■	■	S	E	1	\$753.69	\$1023.77	\$ 840.33	\$1110.41	\$1677.71	\$2014.99	\$1900.59	\$2283.95
72"(1829mm)		TCRP-3672-	■	■	S	E	1	824.60	1141.75	916.28	1233.43	1902.36	2300.55	2166.26	2620.02	
20"(508mm)	30"(762mm)	48"(1219mm)	TCRP-3048-	■	■	S	E	2	\$644.49	\$ 858.37	\$ 722.73	\$ 936.61	\$1319.95	\$1584.49	\$1476.89	\$1776.18
		60"(1524mm)	TCRP-3060-	■	■	S	E	2	704.04	959.84	786.48	1042.28	1508.54	1827.34	1699.96	2061.96
		72"(1829mm)	TCRP-3072-	■	■	S	E	2	764.28	1066.12	850.92	1152.76	1699.24	2077.62	1925.59	2356.45
	36"(914mm)	60"(1524mm)	TCRP-3660-	■	■	S	E	2	\$758.94	\$1029.02	\$ 845.58	\$1115.66	\$1682.96	\$2020.24	\$1905.84	\$2289.20
72"(1829mm)		TCRP-3672-	■	■	S	E	2	829.85	1147.00	921.53	1238.68	1907.61	2305.80	2171.51	2625.27	
29"(737mm)	30"(762mm)	48"(1219mm)	TCRP-3048-	■	■	S	E	4	\$660.25	\$ 874.13	\$ 738.49	\$ 952.37	\$1335.71	\$1600.25	\$1492.65	\$1791.94
		60"(1524mm)	TCRP-3060-	■	■	S	E	4	719.80	975.60	802.24	1058.04	1524.30	1843.10	1715.72	2077.72
		72"(1829mm)	TCRP-3072-	■	■	S	E	4	780.04	1081.88	866.68	1168.52	1715.00	2093.38	1941.35	2372.21
	36"(914mm)	60"(1524mm)	TCRP-3660-	■	■	S	E	4	\$774.70	\$1044.78	\$ 861.34	\$1131.42	\$1698.72	\$2036.00	\$1921.60	\$2304.96
72"(1829mm)		TCRP-3672-	■	■	S	E	4	845.61	1162.76	937.29	1254.44	1923.37	2321.56	2187.27	2641.03	
42"(1067mm)	72"(1829mm)	TCRP-4272-	■	■	S	E	4	\$911.18	\$1243.64	\$1007.90	\$1340.36	\$2131.73	\$2549.73	\$2433.19	\$2909.85	
		TCRP-4872-	■	■	S	E	4	\$976.76	\$1324.52	\$1078.52	\$1426.28	\$2340.10	\$2777.91	\$2679.11	\$3178.67	

This page intentionally blank

Jive Table — Post Extruded Base

Rectangle – Laminate or Wood

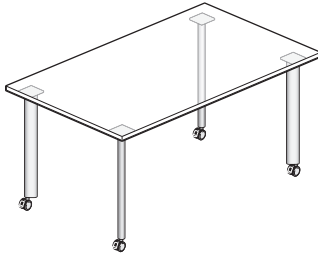

TCRA

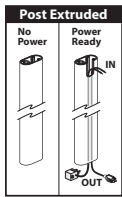

Features

- Includes 1 3/16" (30mm) thick top, leg bases, adjustable glides or casters, and hardware.
- Standard table heights are 16" (406mm), 20" (508mm) and 29" (737mm).
- Laminate top with knife edge or 3mm edgeband edges or wood veneer top with 3mm wood edgeband or knife edge.
- Bases are painted steel.
- Casters:
 - Two locking and two non-locking casters with 5/8" (16mm) adjustment.
 - Standard in black.
- Glides:
 - 5/8" (16mm) adjustment.
 - Standard in black.
- Casters and glides are not interchangeable.
- Depth and width shown in nominal dimensions.
- Ships unassembled.

Specification Tips

- Edge choice allows a flat seam between tables.
- **Specifying a cutout does not automatically include a Power Ready base.**
- Factory installed cutout is available for:
 - Specify the (F) option for a Center, Single-Sided/4 outlet Flip Top Unit
 - Specify the (J) option for a Center, Single-Sided/6 outlet Flip Top Unit
 - Specify the (M) option for a Center, Double-Sided/8 outlet Flip Top Unit
 - Specify the (Q) option for a Center, Double-Sided/12 outlet Flip Top Unit
- Power Ready Base:
 - Allows for cord management through one of the Post Extruded legs.
- **Powered leg location determined during installation.**
 - Casters and Glides:
 - Specify the (J) option for Casters on the Power Ready base (only available on 29" (737mm) high tables)
 - Specify the (K) option for Glides on the Power Ready base (available on 16" (406mm), 20" (508mm) and 29" (737mm) high tables)
 - Flip Top Unit circuit breaker plug fits Power Ready Base opening.
- **Power cord length determines the distance to building power source.**
- Separately specified:
 - Ganging Mechanism - Recommended for use with power between tables.
 - Horizontal and Vertical Wire Management
 - Power and Data Components
 - Accessories
- Refer to Specification Guide:
 - Accessory placement and compatibility.
 - Seating capacities and leg locations.
 - Information on electrical components compatible with factory cut opening.
 - Power Ready base cable capacity.
- Application may require approval of local authority having jurisdiction (AHJ); ensure compliance before placing orders and installation.

To Order, Specify:

1) Product number, including:

1 Surface Option:

- L** Laminate
- W** Wood

2 Edge Option:

Laminate:

- J** Edgeband
- F** Knife

Wood:

- K** Edgeband
- U** Knife

3 Cutout:

- N** No Cutout
- F** Center, Single-Sided/4 outlets, add **\$33.13** list
- J** Center, Single-Sided/6 outlets, add **\$33.13** list
- M** Center, Double-Sided/8 outlets, add **\$33.13** list
- Q** Center, Double-Sided/12 outlets, add **\$33.13** list

4 Base and Wire Management Option:

Base - No Power:

- C** Casters, add **\$15.60** list (29" Height Only)
- G** Glides

Base - Power Ready:

- J** Casters, add **\$15.60** list (29" Height Only)
- K** Glides

2) Laminate surface color or wood finish color.

3) Edgeband trim color (laminated only).

4) Base trim color.

Note: **\$41.60** upcharge list for Metallic trim colors.

Jive Table — Post Extruded Base

Rectangle – Laminate or Wood

Height	Depth	Width	Number	① ② ③ ④	Laminate A		Laminate B		Wood Group A		Wood Group B			
					J	F	J	F	K	U	K	U		
Base — No Power — No Cutout														
16"(406mm)	30"(762mm)	48"(1219mm)	TCRA-3048-	S E	1	\$619.24	\$ 833.12	\$ 697.48	\$ 911.36	\$1294.70	\$1559.24	\$1451.64	\$1750.93	
		54"(1372mm)	TCRA-3054-	S E	1	648.93	883.25	729.27	963.59	1388.73	1679.74	1562.85	1892.73	
		60"(1524mm)	TCRA-3060-	S E	1	678.79	934.59	761.23	1017.03	1483.29	1802.09	1674.71	2036.71	
	36"(914mm)	60"(1524mm)	TCRA-3660-	S E	1	\$733.69	\$1003.77	\$ 820.33	\$1090.41	\$1657.71	\$1994.99	\$1880.59	\$2263.95	
		72"(1829mm)	TCRA-3672-	S E	1	804.60	1121.75	896.28	1213.43	1882.36	2280.55	2146.26	2600.02	
20"(508mm)	30"(762mm)	48"(1219mm)	TCRA-3048-	S E	2	\$624.49	\$ 838.37	\$ 702.73	\$ 916.61	\$1299.95	\$1564.49	\$1456.89	\$1756.18	
		54"(1372mm)	TCRA-3054-	S E	2	654.18	888.50	734.52	968.84	1393.98	1684.99	1568.10	1897.98	
		60"(1524mm)	TCRA-3060-	S E	2	684.04	939.84	766.48	1022.28	1488.54	1807.34	1679.96	2041.96	
	36"(914mm)	60"(1524mm)	TCRA-3660-	S E	2	\$738.94	\$1009.02	\$ 825.58	\$1095.66	\$1662.96	\$2000.24	\$1885.84	\$2269.20	
		72"(1829mm)	TCRA-3672-	S E	2	809.85	1127.00	901.53	1218.68	1887.61	2285.80	2151.51	2605.27	
29"(737mm)	18"(457mm)	48"(1219mm)	TCRA-1848-	S E	4	\$551.80	N/A	\$ 623.32	N/A	\$1034.76	N/A	\$1140.97	N/A	
		54"(1372mm)	TCRA-1854-	S E	4	570.81	N/A	643.59	N/A	1094.85	N/A	1212.14	N/A	
		60"(1524mm)	TCRA-1860-	S E	4	590.00	N/A	664.04	N/A	1155.46	N/A	1283.96	N/A	
		66"(1676mm)	TCRA-1866-	S E	4	609.36	N/A	684.66	N/A	1216.60	N/A	1356.42	N/A	
		72"(1829mm)	TCRA-1872-	S E	4	628.89	N/A	705.45	N/A	1278.27	N/A	1429.51	N/A	
	24"(610mm)	36"(914mm)	TCRA-2436-	S E	4	\$547.84	\$ 711.68	\$ 619.36	\$ 783.20	\$1022.70	\$1222.49	\$1126.33	\$1350.77	
			TCRA-2442-	S E	4	571.85	753.56	645.05	826.76	1098.70	1321.63	1216.25	1467.43	
		48"(1219mm)	TCRA-2448-	S E	4	596.03	796.65	670.91	871.53	1175.24	1422.63	1306.81	1586.27	
			TCRA-2454-	S E	4	620.38	840.93	696.94	917.49	1252.29	1525.49	1398.00	1707.29	
			TCRA-2460-	S E	4	644.90	886.42	723.14	964.66	1329.88	1630.20	1489.84	1830.48	
			TCRA-2466-	S E	4	669.60	933.11	749.52	1013.03	1407.99	1736.77	1582.32	1955.85	
			TCRA-2472-	S E	4	694.46	981.00	776.06	1062.60	1486.63	1845.20	1675.43	2083.40	
			30"(762mm)	TCRA-3036-	S E	4	\$581.40	\$ 757.46	\$ 655.44	\$ 831.50	\$1129.23	\$1344.83	\$1252.13	\$1494.86
				TCRA-3042-	S E	4	610.74	805.19	686.88	881.33	1222.20	1461.61	1362.07	1632.31
				TCRA-3048-	S E	4	640.25	854.13	718.49	932.37	1315.71	1580.25	1472.65	1771.94
				TCRA-3054-	S E	4	669.94	904.26	750.28	984.60	1409.74	1700.75	1583.86	1913.74
				TCRA-3060-	S E	4	699.80	955.60	782.24	1038.04	1504.30	1823.10	1695.72	2057.72
				TCRA-3072-	S E	4	760.04	1061.88	846.68	1148.52	1695.00	2073.38	1921.35	2352.21
			36"(914mm)	60"(1524mm)	TCRA-3660-	S E	4	\$754.70	\$1024.78	\$ 841.34	\$1111.42	\$1678.72	\$2016.00	\$1901.60
66"(1676mm)	TCRA-3666-	S E		4	790.07	1083.17	879.23	1172.33	1790.78	2157.85	2034.11	2451.91		
72"(1829mm)	TCRA-3672-	S E		4	825.61	1142.76	917.29	1234.44	1903.37	2301.56	2167.27	2621.03		
42"(1067mm)	60"(1524mm)	TCRA-4260-	S E	4	\$809.60	\$1093.96	\$ 900.44	\$1184.80	\$1853.14	\$2208.90	\$2107.48	\$2512.20		
	72"(1829mm)	TCRA-4272-	S E	4	891.18	1223.64	987.90	1320.36	2111.73	2529.73	2413.19	2889.85		
48"(1219mm)	72"(1829mm)	TCRA-4872-	S E	4	\$956.76	\$1304.52	\$1058.52	\$1406.28	\$2320.10	\$2757.91	\$2659.11	\$3158.67		

Jive Table — Post Extruded Base

Rectangle – Laminate or Wood

Height	Depth	Width	Number	①	②	③	④	Laminate A		Laminate B		Wood Group A		Wood Group B		
								J	F	J	F	K	U	K	U	
Base — Power Ready — No Cutout																
16"(406mm)	30"(762mm)	48"(1219mm)	TCRA-3048-		S	E	1	\$639.24	\$ 853.12	\$ 717.48	\$ 931.36	\$1314.70	\$1579.24	\$1471.64	\$1770.93	
		54"(1372mm)	TCRA-3054-		S	E	1	668.93	903.25	749.27	983.59	1408.73	1699.74	1582.85	1912.73	
		60"(1524mm)	TCRA-3060-		S	E	1	698.79	954.59	781.23	1037.03	1503.29	1822.09	1694.71	2056.71	
		36"(914mm)	60"(1524mm)	TCRA-3660-		S	E	1	\$753.69	\$1023.77	\$ 840.33	\$1110.41	\$1677.71	\$2014.99	\$1900.59	\$2283.95
20"(508mm)	30"(762mm)	48"(1219mm)	TCRA-3048-		S	E	2	\$644.49	\$ 858.37	\$ 722.73	\$ 936.61	\$1319.95	\$1584.49	\$1476.89	\$1776.18	
		54"(1372mm)	TCRA-3054-		S	E	2	674.18	908.50	754.52	988.84	1413.98	1704.99	1588.10	1917.98	
		60"(1524mm)	TCRA-3060-		S	E	2	704.04	959.84	786.48	1042.28	1508.54	1827.34	1699.96	2061.96	
		36"(914mm)	60"(1524mm)	TCRA-3660-		S	E	2	\$758.94	\$1029.02	\$ 845.58	\$1115.66	\$1682.96	\$2020.24	\$1905.84	\$2289.20
29"(737mm)	18"(457mm)	48"(1219mm)	TCRA-1848-		S	E	4	\$571.80	N/A	\$ 643.32	N/A	\$1054.76	N/A	\$1160.97	N/A	
		54"(1372mm)	TCRA-1854-		S	E	4	590.81	N/A	663.59	N/A	1114.85	N/A	1232.14	N/A	
		60"(1524mm)	TCRA-1860-		S	E	4	610.00	N/A	684.04	N/A	1175.46	N/A	1303.96	N/A	
		66"(1676mm)	TCRA-1866-		S	E	4	629.36	N/A	704.66	N/A	1236.60	N/A	1376.42	N/A	
24"(610mm)	36"(914mm)	48"(1219mm)	TCRA-2436-		S	E	4	\$567.84	\$ 731.68	\$ 639.36	\$ 803.20	\$1042.70	\$1242.49	\$1146.33	\$1370.77	
		42"(1067mm)	TCRA-2442-		S	E	4	591.85	773.56	665.05	846.76	1118.70	1341.63	1236.25	1487.43	
		48"(1219mm)	TCRA-2448-		S	E	4	616.03	816.65	690.91	891.53	1195.24	1442.63	1326.81	1606.27	
		54"(1372mm)	TCRA-2454-		S	E	4	640.38	860.93	716.94	937.49	1272.29	1545.49	1418.00	1727.29	
		60"(1524mm)	TCRA-2460-		S	E	4	664.90	906.42	743.14	984.66	1349.88	1650.20	1509.84	1850.48	
		66"(1676mm)	TCRA-2466-		S	E	4	689.60	953.11	769.52	1033.03	1427.99	1756.77	1602.32	1975.85	
		72"(1829mm)	TCRA-2472-		S	E	4	714.46	1001.00	796.06	1082.60	1506.63	1865.20	1695.43	2103.40	
		30"(762mm)	36"(914mm)	TCRA-3036-		S	E	4	\$601.40	\$ 777.46	\$ 675.44	\$ 851.50	\$1149.23	\$1364.83	\$1272.13	\$1514.86
		42"(1067mm)	TCRA-3042-		S	E	4	630.74	825.19	706.88	901.33	1242.20	1481.61	1382.07	1652.31	
		48"(1219mm)	TCRA-3048-		S	E	4	660.25	874.13	738.49	952.37	1335.71	1600.25	1492.65	1791.94	
		54"(1372mm)	TCRA-3054-		S	E	4	689.94	924.26	770.28	1004.60	1429.74	1720.75	1603.86	1933.74	
		60"(1524mm)	TCRA-3060-		S	E	4	719.80	975.60	802.24	1058.04	1524.30	1843.10	1715.72	2077.72	
72"(1829mm)	TCRA-3072-		S	E	4	780.04	1081.88	866.68	1168.52	1715.00	2093.38	1941.35	2372.21			
36"(914mm)	60"(1524mm)	TCRA-3660-		S	E	4	\$774.70	\$1044.78	\$ 861.34	\$1131.42	\$1698.72	\$2036.00	\$1921.60	\$2304.96		
		66"(1676mm)	TCRA-3666-		S	E	4	810.07	1103.17	899.23	1192.33	1810.78	2177.85	2054.11	2471.91	
		72"(1829mm)	TCRA-3672-		S	E	4	845.61	1162.76	937.29	1254.44	1923.37	2321.56	2187.27	2641.03	
42"(1067mm)	60"(1524mm)	TCRA-4260-		S	E	4	\$829.60	\$1113.96	\$ 920.44	\$1204.80	\$1873.14	\$2228.90	\$2127.48	\$2532.20		
		72"(1829mm)	TCRA-4272-		S	E	4	911.18	1243.64	1007.90	1340.36	2131.73	2549.73	2433.19	2909.85	
48"(1219mm)	72"(1829mm)	TCRA-4872-		S	E	4	\$976.76	\$1324.52	\$1078.52	\$1426.28	\$2340.10	\$2777.91	\$2679.11	\$3178.67		

Jive Table — Post Extruded Base

Racetrack – Laminate or Wood

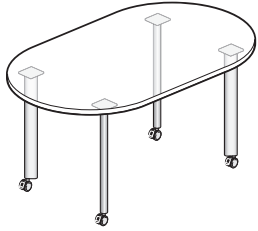

TCRT

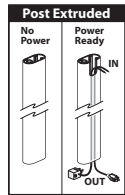

Features

- Includes 1 3/16”(30mm) thick top, leg bases, adjustable glides or casters, and hardware.
- Standard table heights are 16”(406mm), 20”(508mm) and 29”(737mm).
- Laminate top with knife edge or 3mm edgeband edges or wood veneer top with 3mm wood edgeband or knife edge.
- Bases are painted steel.
- 16”(406mm) and 20”(508mm) heights are available with glides only.
- 29”(737mm) height available with glides or casters.
- Casters:
 - Two locking and two non-locking casters with 5/8”(16mm) adjustment.
 - Standard in black.
- Glides:
 - 5/8”(16mm) adjustment.
 - Standard in black.
- Casters and glides are not interchangeable.
- Depth and width shown in nominal dimensions.
- Ships unassembled.

Specification Tips

- **Specifying a cutout does not automatically include a Power Ready base.**
 - Factory installed cutout is available for:
 - Specify the (F) option for a Center, Single-Sided/4 outlet Flip Top Unit
 - Specify the (J) option for a Center, Single-Sided/6 outlet Flip Top Unit
 - Specify the (M) option for a Center, Double-Sided/8 outlet Flip Top Unit
 - Specify the (Q) option for a Center, Double-Sided/12 outlet Flip Top Unit
- **Power Ready Base:**
 - Allows for cord management through one of the Post Extruded legs.
- **Powered leg location determined during installation.**
 - Casters and Glides:
 - Specify the (J) option for Casters on the Power Ready base (only available on 29”(737mm) high tables)
 - Specify the (K) option for Glides on the Power Ready base (available on 16”(406mm), 20”(508mm) and 29”(737mm) high tables)
 - Flip Top Unit circuit breaker plug fits Power Ready Base opening.
- **Power cord length determines the distance to building power source.**
- Separately specified:
 - Horizontal and Vertical Wire Management
 - Power and Data Components
 - Accessories
- Refer to Specification Guide:
 - Accessory placement and compatibility.
 - Seating capacities and leg locations.
 - Information on electrical components compatible with factory cut opening.
 - Power Ready base cable capacity.
- Application may require approval of local authority having jurisdiction (AHJ); ensure compliance before placing orders and installation.

To Order, Specify:

1) Product number, including:

1 Surface Option:

- L** Laminate
- W** Wood

2 Edge Option:

Laminate:

- J** Edgeband
- F** Knife

Wood:

- K** Edgeband
- U** Knife

3 Cutout:

- N** No Cutout
- F** Center, Single-Sided/4 outlets, add **\$33.13** list
- J** Center, Single-Sided/6 outlets, add **\$33.13** list
- M** Center, Double-Sided/8 outlets, add **\$33.13** list
- Q** Center, Double-Sided/12 outlets, add **\$33.13** list

4 Base and Wire Management Option:

Base - No Power:

- C** Casters, add **\$15.60** list (29” Height Only)
- G** Glides

Base - Power Ready:

- J** Casters, add **\$15.60** list (29” Height Only)
- K** Glides

2) Laminate surface color or wood finish color.

3) Edgeband trim color (laminated only).

4) Base trim color.

Note: **\$41.60** upcharge list for Metallic trim colors.

Jive Table — Post Extruded Base

Racetrack – Laminate or Wood

Height	Depth	Width	Number	①	②	③	④	Laminate A		Laminate B		Wood Group A		Wood Group B		
								J	F	J	F	K	U	K	U	
Base — No Power — No Cutout																
16"(406mm)	30"(762mm)	48"(1219mm)	TCRT-3048-	■	■	S	E	1	\$619.24	\$ 833.12	\$ 697.48	\$ 911.36	\$1294.70	\$1559.24	\$1451.64	\$1750.93
		60"(1524mm)	TCRT-3060-	■	■	S	E	1	678.79	934.59	761.23	1017.03	1483.29	1802.09	1674.71	2036.71
		72"(1829mm)	TCRT-3072-	■	■	S	E	1	739.03	1040.87	825.67	1127.51	1673.99	2052.37	1900.34	2331.20
	36"(914mm)	60"(1524mm)	TCRT-3660-	■	■	S	E	1	\$733.69	\$1003.77	\$ 820.33	\$1090.41	\$1657.71	\$1994.99	\$1880.59	\$2263.95
		72"(1829mm)	TCRT-3672-	■	■	S	E	1	804.60	1121.75	896.28	1213.43	1882.36	2280.55	2146.26	2600.02
		42"(1067mm)	TCRT-4272-	■	■	S	E	4	\$891.18	\$1223.64	\$ 987.90	\$1320.36	\$2111.73	\$2529.73	\$2413.19	\$2889.85
20"(508mm)	30"(762mm)	48"(1219mm)	TCRT-3048-	■	■	S	E	2	\$624.49	\$ 838.37	\$ 702.73	\$ 916.61	\$1299.95	\$1564.49	\$1456.89	\$1756.18
		60"(1524mm)	TCRT-3060-	■	■	S	E	2	684.04	939.84	766.48	1022.28	1488.54	1807.34	1679.96	2041.96
		72"(1829mm)	TCRT-3072-	■	■	S	E	2	744.28	1046.12	830.92	1132.76	1679.24	2057.62	1905.59	2336.45
	36"(914mm)	60"(1524mm)	TCRT-3660-	■	■	S	E	2	\$738.94	\$1009.02	\$ 825.58	\$1095.66	\$1662.96	\$2000.24	\$1885.84	\$2269.20
		72"(1829mm)	TCRT-3672-	■	■	S	E	2	809.85	1127.00	901.53	1218.68	1887.61	2285.80	2151.51	2605.27
		42"(1067mm)	TCRT-4272-	■	■	S	E	4	\$891.18	\$1223.64	\$ 987.90	\$1320.36	\$2111.73	\$2529.73	\$2413.19	\$2889.85
29"(737mm)	30"(762mm)	48"(1219mm)	TCRT-3048-	■	■	S	E	4	\$640.25	\$ 854.13	\$ 718.49	\$ 932.37	\$1315.71	\$1580.25	\$1472.65	\$1771.94
		60"(1524mm)	TCRT-3060-	■	■	S	E	4	699.80	955.60	782.24	1038.04	1504.30	1823.10	1695.72	2057.72
		72"(1829mm)	TCRT-3072-	■	■	S	E	4	760.04	1061.88	846.68	1148.52	1695.00	2073.38	1921.35	2352.21
	36"(914mm)	60"(1524mm)	TCRT-3660-	■	■	S	E	4	\$754.70	\$1024.78	\$ 841.34	\$1111.42	\$1678.72	\$2016.00	\$1901.60	\$2284.96
		72"(1829mm)	TCRT-3672-	■	■	S	E	4	825.61	1142.76	917.29	1234.44	1903.37	2301.56	2167.27	2621.03
		42"(1067mm)	TCRT-4272-	■	■	S	E	4	\$891.18	\$1223.64	\$ 987.90	\$1320.36	\$2111.73	\$2529.73	\$2413.19	\$2889.85
48"(1219mm)	TCRT-4872-	■	■	S	E	4	\$956.76	\$1304.52	\$1058.52	\$1406.28	\$2320.10	\$2757.91	\$2659.11	\$3158.67		
Base — Power Ready — No Cutout																
16"(406mm)	30"(762mm)	48"(1219mm)	TCRT-3048-	■	■	S	E	1	\$639.24	\$ 853.12	\$ 717.48	\$ 931.36	\$1314.70	\$1579.24	\$1471.64	\$1770.93
		60"(1524mm)	TCRT-3060-	■	■	S	E	1	698.79	954.59	781.23	1037.03	1503.29	1822.09	1694.71	2056.71
		72"(1829mm)	TCRT-3072-	■	■	S	E	1	759.03	1060.87	845.67	1147.51	1693.99	2072.37	1920.34	2351.20
	36"(914mm)	60"(1524mm)	TCRT-3660-	■	■	S	E	1	\$753.69	\$1023.77	\$ 840.33	\$1110.41	\$1677.71	\$2014.99	\$1900.59	\$2283.95
		72"(1829mm)	TCRT-3672-	■	■	S	E	1	824.60	1141.75	916.28	1233.43	1902.36	2300.55	2166.26	2620.02
		42"(1067mm)	TCRT-4272-	■	■	S	E	4	\$891.18	\$1223.64	\$ 987.90	\$1320.36	\$2111.73	\$2529.73	\$2413.19	\$2889.85
20"(508mm)	30"(762mm)	48"(1219mm)	TCRT-3048-	■	■	S	E	2	\$644.49	\$ 858.37	\$ 722.73	\$ 936.61	\$1319.95	\$1584.49	\$1476.89	\$1776.18
		60"(1524mm)	TCRT-3060-	■	■	S	E	2	704.04	959.84	786.48	1042.28	1508.54	1827.34	1699.96	2061.96
		72"(1829mm)	TCRT-3072-	■	■	S	E	2	764.28	1066.12	850.92	1152.76	1699.24	2077.62	1925.59	2356.45
	36"(914mm)	60"(1524mm)	TCRT-3660-	■	■	S	E	2	\$758.94	\$1029.02	\$ 845.58	\$1115.66	\$1682.96	\$2020.24	\$1905.84	\$2289.20
		72"(1829mm)	TCRT-3672-	■	■	S	E	2	829.85	1147.00	921.53	1238.68	1907.61	2305.80	2171.51	2625.27
		42"(1067mm)	TCRT-4272-	■	■	S	E	4	\$891.18	\$1223.64	\$ 987.90	\$1320.36	\$2111.73	\$2529.73	\$2413.19	\$2889.85
29"(737mm)	30"(762mm)	48"(1219mm)	TCRT-3048-	■	■	S	E	4	\$660.25	\$ 874.13	\$ 738.49	\$ 952.37	\$1335.71	\$1600.25	\$1492.65	\$1791.94
		60"(1524mm)	TCRT-3060-	■	■	S	E	4	719.80	975.60	802.24	1058.04	1524.30	1843.10	1715.72	2077.72
		72"(1829mm)	TCRT-3072-	■	■	S	E	4	780.04	1081.88	866.68	1168.52	1715.00	2093.38	1941.35	2372.21
	36"(914mm)	60"(1524mm)	TCRT-3660-	■	■	S	E	4	\$774.70	\$1044.78	\$ 861.34	\$1131.42	\$1698.72	\$2036.00	\$1921.60	\$2304.96
		72"(1829mm)	TCRT-3672-	■	■	S	E	4	845.61	1162.76	937.29	1254.44	1923.37	2321.56	2187.27	2641.03
		42"(1067mm)	TCRT-4272-	■	■	S	E	4	\$891.18	\$1223.64	\$ 987.90	\$1320.36	\$2111.73	\$2529.73	\$2413.19	\$2889.85
48"(1219mm)	TCRT-4872-	■	■	S	E	4	\$976.76	\$1324.52	\$1078.52	\$1426.28	\$2340.10	\$2777.91	\$2679.11	\$3178.67		

Jive Table — Post Extruded Base

Trapezoid – Laminate or Wood

Height	Depth	Width	Number	Laminate A		Laminate B		Wood Group A		Wood Group B				
				J	F	J	F	K	U	K	U			
Base — No Power — No Cutout														
29"(737mm)	24"(610mm)	48"(1219mm)	TCTP-2448-	S	E	4	\$596.03	\$ 796.65	\$599.39	\$ 800.01	\$ 742.50	\$ 989.89	\$ 783.79	\$1063.25
		54"(1372mm)	TCTP-2454-	S	E	4	620.38	840.93	625.42	845.97	819.55	1092.75	874.98	1184.27
		60"(1524mm)	TCTP-2460-	S	E	4	644.90	886.42	651.62	893.14	897.14	1197.46	966.82	1307.46
		66"(1676mm)	TCTP-2466-	S	E	4	669.60	933.11	678.00	941.51	975.25	1304.03	1059.30	1432.83
		72"(1829mm)	TCTP-2472-	S	E	4	694.46	981.00	704.54	991.08	1053.89	1412.46	1152.41	1560.38
		30"(762mm)	60"(1524mm)	TCTP-3060-	S	E	4	\$699.80	\$ 955.60	\$710.72	\$ 966.52	\$1071.56	\$1390.36	\$1172.70
30"(762mm)	66"(1676mm)	TCTP-3066-	S	E	4	729.83	1008.14	742.85	1021.16	1166.65	1514.57	1285.19	1680.86	
		72"(1829mm)	TCTP-3072-	S	E	4	760.04	1061.88	775.16	1077.00	1262.26	1640.64	1398.33	1829.19
		36"(914mm)	84"(2134mm)	TCTP-3684-	S	E	4	\$897.21	\$1265.54	\$922.41	\$1290.74	\$1697.38	\$2161.80	\$1912.47
Base — Power Ready — No Cutout														
29"(737mm)	24"(610mm)	48"(1219mm)	TCTP-2448-	S	E	4	\$616.03	\$ 816.65	\$619.39	\$ 820.01	\$ 762.50	\$1009.89	\$ 803.79	\$1083.25
		54"(1372mm)	TCTP-2454-	S	E	4	640.38	860.93	645.42	865.97	839.55	1112.75	894.98	1204.27
		60"(1524mm)	TCTP-2460-	S	E	4	664.90	906.42	671.62	913.14	917.14	1217.46	986.82	1327.46
		66"(1676mm)	TCTP-2466-	S	E	4	689.60	953.11	698.00	961.51	995.25	1324.03	1079.30	1452.83
		72"(1829mm)	TCTP-2472-	S	E	4	714.46	1001.00	724.54	1011.08	1073.89	1432.46	1172.41	1580.38
		30"(762mm)	60"(1524mm)	TCTP-3060-	S	E	4	\$719.80	\$ 975.60	\$730.72	\$ 986.52	\$1091.56	\$1410.36	\$1192.70
30"(762mm)	66"(1676mm)	TCTP-3066-	S	E	4	749.83	1028.14	762.85	1041.16	1186.65	1534.57	1305.19	1700.86	
		72"(1829mm)	TCTP-3072-	S	E	4	780.04	1081.88	795.16	1097.00	1282.26	1660.64	1418.33	1849.19
		36"(914mm)	84"(2134mm)	TCTP-3684-	S	E	4	\$917.21	\$1285.54	\$942.41	\$1310.74	\$1717.38	\$2181.80	\$1932.47

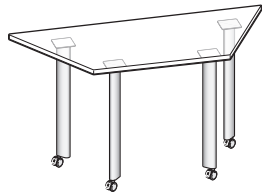

TCTP

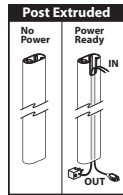

Features

- Includes 1 3/16"(30mm) thick top, leg bases, adjustable glides or casters, and hardware.
- Standard table height is 29"(737mm).
- Laminate top with knife edge or 3mm edgeband edges or wood veneer top with 3mm wood edgeband or knife edge.
- Bases are painted steel.
- Casters:
 - Two locking and two non-locking casters with 5/8"(16mm) adjustment.
 - Standard in black.
- Glides:
 - 5/8"(16mm) adjustment.
 - Standard in black.
- Casters and glides are not interchangeable.
- Depth and width shown in nominal dimensions.
- Ships unassembled.

Specification Tips

- Edge choice allows a flat seam between tables.
- **Specifying a cutout does not automatically include a Power Ready base.**
- Factory installed cutout is available for:
 - Specify the (F) option for a Center, Single-Sided/4 outlet Flip Top Unit
 - Specify the (J) option for a Center, Single-Sided/6 outlet Flip Top Unit
 - Specify the (M) option for a Center, Double-Sided/8 outlet Flip Top Unit
 - Specify the (Q) option for a Center, Double-Sided/12 outlet Flip Top Unit
- Power Ready Base:
 - Allows for cord management through one of the Post Extruded legs.
- **Powered leg location determined during installation.**
 - Casters and Glides:
 - Specify the (J) option for Casters on the Power Ready base (only available on 29"(737mm) high tables)
 - Specify the (K) option for Glides on the Power Ready base (available on 29"(737mm) high tables)
 - Flip Top Unit circuit breaker plug fits Power Ready Base opening.
- **Power cord length determines the distance to building power source.**
- Separately specified:
 - Ganging Mechanism - Recommended for use with power between tables.
 - Horizontal and Vertical Wire Management
 - Power and Data Components
 - Accessories
- Refer to Specification Guide:
 - Accessory placement and compatibility.
 - Seating capacities and leg locations.
 - Information on electrical components compatible with factory cut opening.
 - Power Ready base cable capacity.
- Application may require approval of local authority having jurisdiction (AHJ); ensure compliance before placing orders and installation.

To Order, Specify:

- 1) Product number, including:

1 Surface Option:

- L Laminate
- W Wood

2 Edge Option:

Laminate:

- J Edgeband
- F Knife

Wood:

- K Edgeband
- U Knife

3 Cutout:

- N No Cutout
- F Center, Single-Sided/4 outlets, add \$33.13 list
- J Center, Single-Sided/6 outlets, add \$33.13 list

4 Base and Wire Management Option:

Base - No Power:

- C Casters, add \$15.60 list (29" Height Only)
- G Glides

Base - Power Ready:

- J Casters, add \$15.60 list (29" Height Only)
- K Glides

- 2) Laminate surface color or wood finish color.
- 3) Edgeband trim color (laminate only).
- 4) Base trim color.

Note: \$41.60 upcharge list for Metallic trim colors.

Jive Table — Post Extruded Base

Crescent – Laminate or Wood

Depth	Width	Number	① ② ③ ④	Laminate A		Laminate B		Wood Group A		Wood Group B						
				J	F	J	F	K	U	K	U					
Base — No Power — No Cutout																
24"(610mm)	60"(1524mm)	TCBN-2460-	■	■	S	E	■	4	\$1052.70	\$1294.22	\$1059.42	\$1300.94	\$1304.94	\$1605.26	\$1374.62	\$1715.26
30"(762mm)	72"(1829mm)	TCBN-3072-	■	■	S	E	■	4	1167.84	1469.68	1182.96	1484.80	1670.06	2048.44	1806.13	2236.99
36"(914mm)	84"(2134mm)	TCBN-3684-	■	■	S	E	■	4	1305.01	1673.34	1330.21	1698.54	2105.18	2569.60	2320.27	2850.59
Base — Power Ready — No Cutout																
24"(610mm)	60"(1524mm)	TCBN-2460-	■	■	S	E	■	4	\$1072.70	\$1314.22	\$1079.42	\$1320.94	\$1324.94	\$1625.26	\$1394.62	\$1735.26
30"(762mm)	72"(1829mm)	TCBN-3072-	■	■	S	E	■	4	1187.84	1489.68	1202.96	1504.80	1690.06	2068.44	1826.13	2256.99
36"(914mm)	84"(2134mm)	TCBN-3684-	■	■	S	E	■	4	1325.01	1693.34	1350.21	1718.54	2125.18	2589.60	2340.27	2870.59

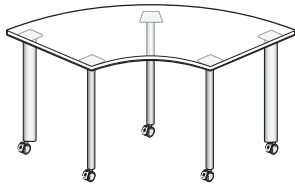

TCBN

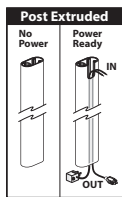

Features

- Includes 1 3/16"(30mm) thick top, leg bases, adjustable glides or casters, and hardware.
- Standard table height is 29"(737mm).
- Laminate top with knife edge or 3mm edgeband edges or wood veneer top with 3mm wood edgeband or knife edge.
- Bases are painted steel.
- Casters:
 - Two locking and two non-locking casters with 5/8"(16mm) adjustment.
 - Standard in black.
- Glides:
 - 5/8"(16mm) adjustment.
 - Standard in black.
- Casters and glides are not interchangeable.
- Depth and width shown in nominal dimensions.
- Ships unassembled.

Specification Tips

- Edge choice allows a flat seam between tables.
- Specifying a cutout does not automatically include a Power Ready base.**
- Factory installed cutout is available for:
 - Specify the (F) option for a Center, Single-Sided/4 outlet Flip Top Unit
 - Specify the (J) option for a Center, Single-Sided/6 outlet Flip Top Unit
- Power Ready Base:
 - Allows for cord management through one of the Post Extruded legs.
 - Powered leg location determined during installation.
 - Casters and Glides:
 - Specify the (J) option for Casters on the Power Ready base (only available on 29"(737mm) high tables)
 - Specify the (K) option for Glides on the Power Ready base (available on 29"(737mm) high tables)
 - Flip Top Unit circuit breaker plug fits Power Ready Base opening.
- Power cord length determines the distance to building power source.**
- Separately specified:
 - Ganging Mechanism - Recommended for use with power between tables.
 - Horizontal and Vertical Wire Management
 - Power and Data Components
 - Accessories
- Refer to Specification Guide:
 - Accessory placement and compatibility.
 - Seating capacities and leg locations.
 - Information on electrical components compatible with factory cut opening.
 - Power Ready base cable capacity.
- Application may require approval of local authority having jurisdiction (AHJ); ensure compliance before placing orders and installation.

To Order, Specify:

- Product number, including:

① Surface Option:

- L Laminate
- W Wood

② Edge Option:

Laminate:

- J Edgeband
- F Knife

Wood:

- K Edgeband
- U Knife

③ Cutout:

- N No Cutout
- F Center, Single-Sided/4 outlets, add \$33.13 list
- J Center, Single-Sided/6 outlets, add \$33.13 list

④ Base and Wire Management Option:

Base - No Power:

- C Casters, add \$15.60 list (29" Height Only)
- G Glides

Base - Power Ready:

- J Casters, add \$15.60 list (29" Height Only)
- K Glides

- Laminate surface color or wood finish color.
- Edgeband trim color (laminate only).
- Base trim color.

Note: \$41.60 upcharge list for Metallic trim colors.

Jive Table — Post Extruded Base

Half Racetrack – Laminate or Wood

Height	Depth	Width	Number	Laminate A		Laminate B		Wood Group A		Wood Group B				
				J	F	J	F	K	U	K	U			
Base — No Power — No Cutout														
29"(737mm)	42"(1067mm)	42"(1067mm)	TCHT-4242-	S	V	4	\$ 734.15	\$ 975.67	\$ 748.01	\$ 989.53	\$1181.21	\$1517.65	\$1301.72	\$1684.70
	48"(1219mm)	48"(1219mm)	TCHT-4848-	S	V	4	817.70	1087.78	837.86	1107.94	1446.50	1907.40	1614.98	2143.24
	54"(1372mm)	54"(1372mm)	TCHT-5454-	S	V	4	911.75	1210.39	939.05	1237.69	1745.21	2351.16	1967.64	2665.31
	60"(1524mm)	60"(1524mm)	TCHT-6060-	S	V	4	1016.30	1343.50	1051.58	1378.78	2077.34	2849.60	2359.70	3251.70
Base — Power Ready — No Cutout														
29"(737mm)	42"(1067mm)	42"(1067mm)	TCHT-4242-	S	V	4	\$ 754.15	\$ 995.67	\$ 768.01	\$1009.53	\$1201.21	\$1537.65	\$1321.72	\$1704.70
	48"(1219mm)	48"(1219mm)	TCHT-4848-	S	V	4	837.70	1107.78	857.86	1127.94	1466.50	1927.40	1634.98	2163.24
	54"(1372mm)	54"(1372mm)	TCHT-5454-	S	V	4	931.75	1230.39	959.05	1257.69	1765.21	2371.16	1987.64	2685.31
	60"(1524mm)	60"(1524mm)	TCHT-6060-	S	V	4	1036.30	1363.50	1071.58	1398.78	2097.34	2869.60	2379.70	3271.70

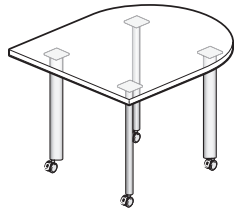

TCHT

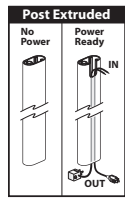

Features

- Includes 1 3/16"(30mm) thick top, leg bases, adjustable glides or casters, and hardware.
- Standard table height is 29"(737mm).
- Laminate top with knife edge or 3mm edgeband edges or wood veneer top with 3mm wood edgeband or knife edge.
- Bases are painted steel.
- Casters:
 - Two locking and two non-locking casters with 5/8"(16mm) adjustment.
 - Standard in black.
- Glides:
 - 5/8"(16mm) adjustment.
 - Standard in black.
- Casters and glides are not interchangeable.
- Depth and width shown in nominal dimensions.
- Ships unassembled.

Specification Tips

- Edge choice allows a flat seam between tables.
- **Specifying a cutout does not automatically include a Power Ready base.**
- Factory installed cutout is available for:
 - Specify the (F) option for a Center, Single-Sided/4 outlet Flip Top Unit
 - Specify the (J) option for a Center, Single-Sided/6 outlet Flip Top Unit
 - Specify the (M) option for a Center, Double-Sided/8 outlet Flip Top Unit
 - Specify the (Q) option for a Center, Double-Sided/12 outlet Flip Top Unit
- Power Ready Base:
 - Allows for cord management through one of the Post Extruded legs.
- **Powered leg location determined during installation.**
 - Casters and Glides:
 - Specify the (J) option for Casters on the Power Ready base (only available on 29"(737mm) high tables)
 - Specify the (K) option for Glides on the Power Ready base (available on 29"(737mm) high tables)
 - Flip Top Unit circuit breaker plug fits Power Ready Base opening.
- **Power cord length determines the distance to building power source.**
- Separately specified:
 - Ganging Mechanism - Recommended for use with power between tables.
 - Horizontal and Vertical Wire Management
 - Power and Data Components
 - Accessories
- Refer to Specification Guide:
 - Accessory placement and compatibility.
 - Seating capacities and leg locations.
 - Information on electrical components compatible with factory cut opening.
 - Power Ready base cable capacity.
- Application may require approval of local authority having jurisdiction (AHJ); ensure compliance before placing orders and installation.

To Order, Specify:

1) Product number, including:

1 Surface Option:

- L** Laminate
- W** Wood

2 Edge Option:

Laminate:

- J** Edgeband
- F** Knife

Wood:

- K** Edgeband
- U** Knife

3 Cutout:

- N** No Cutout
- F** Center, Single-Sided/4 outlets, add \$33.13 list
- J** Center, Single-Sided/6 outlets, add \$33.13 list
- M** Center, Double-Sided/8 outlets, add \$33.13 list
- Q** Center, Double-Sided/12 outlets, add \$33.13 list

4 Base and Wire Management Option:

Base - No Power:

- C** Casters, add \$15.60 list (29" Height Only)
- G** Glides

Base - Power Ready:

- J** Casters, add \$15.60 list (29" Height Only)
- K** Glides

- 2) Laminate surface color or wood finish color.
- 3) Edgeband trim color (laminates only).
- 4) Base trim color.

Note: \$41.60 upcharge list for Metallic trim colors.

Jive Table — Post Extruded Base

Pebble Half – Laminate or Wood

Height	Depth	Width	Number					Laminate A		Laminate B		Wood Group A		Wood Group B		
				①	②	③	④	J	F	J	F	K	U	K	U	
Base — No Power — No Cutout																
29"(737mm)	42"(1067mm)	42"(1067mm)	TCHP-4242-	■	■	S	V	4	\$ 734.15	\$ 975.67	\$ 748.01	\$ 989.53	\$1181.21	\$1517.65	\$1301.72	\$1684.70
	48"(1219mm)	48"(1219mm)	TCHP-4848-	■	■	S	V	4	817.70	1087.78	837.86	1107.94	1446.50	1907.40	1614.98	2143.24
	54"(1372mm)	54"(1372mm)	TCHP-5454-	■	■	S	V	4	911.75	1210.39	939.05	1237.69	1745.21	2351.16	1967.64	2665.31
	60"(1524mm)	60"(1524mm)	TCHP-6060-	■	■	S	V	4	1016.30	1343.50	1051.58	1378.78	2077.34	2849.60	2359.70	3251.70
Base — Power Ready — No Cutout																
29"(737mm)	42"(1067mm)	42"(1067mm)	TCHP-4242-	■	■	S	V	4	\$ 754.15	\$ 995.67	\$ 768.01	\$1009.53	\$1201.21	\$1537.65	\$1321.72	\$1704.70
	48"(1219mm)	48"(1219mm)	TCHP-4848-	■	■	S	V	4	837.70	1107.78	857.86	1127.94	1466.50	1927.40	1634.98	2163.24
	54"(1372mm)	54"(1372mm)	TCHP-5454-	■	■	S	V	4	931.75	1230.39	959.05	1257.69	1765.21	2371.16	1987.64	2685.31
	60"(1524mm)	60"(1524mm)	TCHP-6060-	■	■	S	V	4	1036.30	1363.50	1071.58	1398.78	2097.34	2869.60	2379.70	3271.70

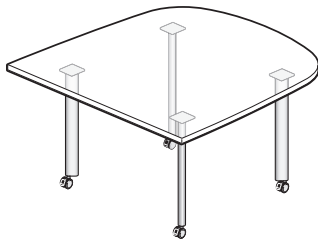

TCHP

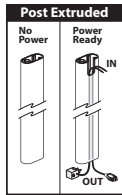

Features

- Includes 1 3/16"(30mm) thick top, leg bases, adjustable glides or casters, and hardware.
- Standard table height is 29"(737mm).
- Laminate top with knife edge or 3mm edgeband edges or wood veneer top with 3mm wood edgeband or knife edge.
- Bases are painted steel.
- Casters:
 - Two locking and two non-locking casters with 5/8"(16mm) adjustment.
 - Standard in black.
- Glides:
 - 5/8"(16mm) adjustment.
 - Standard in black.
- Casters and glides are not interchangeable.
- Depth and width shown in nominal dimensions.
- Ships unassembled.

Specification Tips

- Edge choice allows a flat seam between tables.
- **Specifying a cutout does not automatically include a Power Ready base.**
- Factory installed cutout is available for:
 - Specify the (F) option for a Center, Single-Sided/4 outlet Flip Top Unit
 - Specify the (J) option for a Center, Single-Sided/6 outlet Flip Top Unit
 - Specify the (M) option for a Center, Double-Sided/8 outlet Flip Top Unit
 - Specify the (Q) option for a Center, Double-Sided/12 outlet Flip Top Unit
- Power Ready Base:
 - Allows for cord management through one of the Post Extruded legs.
- **Powered leg location determined during installation.**
 - Casters and Glides:
 - Specify the (J) option for Casters on the Power Ready base (only available on 29"(737mm) high tables)
 - Specify the (K) option for Glides on the Power Ready base (available on 29"(737mm) high tables)
 - Flip Top Unit circuit breaker plug fits Power Ready Base opening.
- **Power cord length determines the distance to building power source.**
- Separately specified:
 - Ganging Mechanism - Recommended for use with power between tables.
 - Horizontal and Vertical Wire Management
 - Power and Data Components
 - Accessories
- Refer to Specification Guide:
 - Accessory placement and compatibility.
 - Seating capacities and leg locations.
 - Information on electrical components compatible with factory cut opening.
 - Power Ready base cable capacity.
- Application may require approval of local authority having jurisdiction (AHJ); ensure compliance before placing orders and installation.

To Order, Specify:

- 1) Product number, including:

① Surface Option:

- L Laminate
- W Wood

② Edge Option:

Laminate:

- J Edgeband
- F Knife

Wood:

- K Edgeband
- U Knife

③ Cutout:

- N No Cutout
- F Center, Single-Sided/4 outlets, add \$33.13 list
- J Center, Single-Sided/6 outlets, add \$33.13 list
- M Center, Double-Sided/8 outlets, add \$33.13 list
- Q Center, Double-Sided/12 outlets, add \$33.13 list

④ Base and Wire Management Option:

Base - No Power:

- C Casters, add \$15.60 list (29" Height Only)
- G Glides

Base - Power Ready:

- J Casters, add \$15.60 list (29" Height Only)
- K Glides

- 2) Laminate surface color or wood finish color.
- 3) Edgeband trim color (laminates only).
- 4) Base trim color.

Note: \$41.60 upcharge list for Metallic trim colors.

Jive Table — Post Round Base

Round – Laminate or Wood

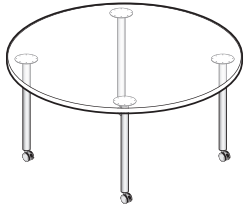

TCRN-SNV

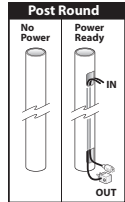

Features

- Includes 1 3/16" (30mm) thick top, leg bases, adjustable glides or casters, and hardware.
- Standard table heights are 16" (406mm), 20" (508mm) and 29" (737mm).
- Laminate top with knife edge or 3mm edgeband edges or wood veneer top with 3mm wood edgeband or knife edge.
- Bases are painted steel.
- Casters:
 - Two locking and two non-locking casters with 5/8" (16mm) adjustment.
 - Standard in black.
- Glides:
 - 5/8" (16mm) adjustment.
 - Standard in black.
- Casters and glides are not interchangeable.
- Depth and width shown in nominal dimensions.
- Ships unassembled.

Specification Tips

- **Specifying a cutout does not automatically include a Power Ready base.**
- Factory installed cutout is available for:
 - Specify the (F) option for a Center, Single-Sided/4 outlet Flip Top Unit
 - Specify the (J) option for a Center, Single-Sided/6 outlet Flip Top Unit
 - Specify the (M) option for a Center, Double-Sided/8 outlet Flip Top Unit
 - Specify the (Q) option for a Center, Double-Sided/12 outlet Flip Top Unit
- Power Ready Base:
 - Allows for cord management through one of the Post Extruded legs.
- **Powered leg location determined during installation.**
 - Casters and Glides:
 - Specify the (J) option for Casters on the Power Ready base (only available on 29" (737mm) high tables)
 - Specify the (K) option for Glides on the Power Ready base (available on 16" (406mm), 20" (508mm) and 29" (737mm) high tables)
 - Flip Top Unit circuit breaker plug fits Power Ready Base opening.
- **Power cord length determines the distance to building power source.**
- Separately specified:
 - Horizontal and Vertical Wire Management
 - Power and Data Components
 - Accessories
- Refer to Specification Guide:
 - Accessory placement and compatibility.
 - Seating capacities and leg locations.
 - Information on electrical components compatible with factory cut opening.
 - Power Ready base cable capacity.
- Application may require approval of local authority having jurisdiction (AHJ); ensure compliance before placing orders and installation.

To Order, Specify:

1) Product number, including:

1 Surface Option:

- L** Laminate
- W** Wood

2 Edge Option:

Laminate:

- J** Edgeband
- F** Knife

Wood:

- K** Edgeband
- U** Knife

3 Cutout:

- N** No Cutout
- F** Center, Single-Sided/4 outlets, add **\$33.13** list
- J** Center, Single-Sided/6 outlets, add **\$33.13** list
- M** Center, Double-Sided/8 outlets, add **\$33.13** list
- Q** Center, Double-Sided/12 outlets, add **\$33.13** list

4 Base and Wire Management Option:

Base - No Power:

- C** Casters, add **\$15.60** list (29" Height Only)

- G** Glides

Base - Power Ready:

- J** Casters, add **\$15.60** list (29" Height Only)

- K** Glides

2) Laminate surface color or wood finish color.

3) Edgeband trim color (laminate only).

4) Base trim color.

Note: **\$41.60** upcharge list for Metallic trim colors.

Jive Table — Post Round Base

Round – Laminate or Wood

Height	Depth	Width	Number					Laminate A		Laminate B		Wood Group A		Wood Group B		
				①	②	③	④	J	F	J	F	K	U	K	U	
Base — No Power — No Cutout																
16"(406mm)	24"(610mm)	24"(610mm)	TCRN-2424-	■	■	S	V	1	\$377.26	\$ 533.10	\$377.26	\$ 533.10	\$ 416.62	\$ 502.64	\$ 429.10	\$ 520.37
	30"(762mm)	30"(762mm)	TCRN-3030-	■	■	S	V	1	429.31	613.71	433.09	617.49	581.65	730.58	624.16	788.56
	36"(914mm)	36"(914mm)	TCRN-3636-	■	■	S	V	1	491.86	704.82	500.26	713.22	780.10	1012.26	858.62	1119.97
	42"(1067mm)	42"(1067mm)	TCRN-4242-	■	■	S	V	1	564.91	806.43	578.77	820.29	1011.97	1348.41	1132.48	1515.46
	48"(1219mm)	48"(1219mm)	TCRN-4848-	■	■	S	V	1	648.46	918.54	668.62	938.70	1277.26	1738.16	1445.74	1974.00
20"(508mm)	24"(610mm)	24"(610mm)	TCRN-2424-	■	■	S	V	2	\$377.26	\$ 533.10	\$377.26	\$ 533.10	\$ 416.62	\$ 502.64	\$ 429.10	\$ 520.37
	30"(762mm)	30"(762mm)	TCRN-3030-	■	■	S	V	2	429.31	613.71	433.09	617.49	581.65	730.58	624.16	788.56
	36"(914mm)	36"(914mm)	TCRN-3636-	■	■	S	V	2	491.86	704.82	500.26	713.22	780.10	1012.26	858.62	1119.97
	42"(1067mm)	42"(1067mm)	TCRN-4242-	■	■	S	V	2	564.91	806.43	578.77	820.29	1011.97	1348.41	1132.48	1515.46
	48"(1219mm)	48"(1219mm)	TCRN-4848-	■	■	S	V	2	648.46	918.54	668.62	938.70	1277.26	1738.16	1445.74	1974.00
29"(737mm)	30"(762mm)	30"(762mm)	TCRN-3030-	■	■	S	V	4	\$429.31	\$ 613.71	\$433.09	\$ 617.49	\$ 581.65	\$ 730.58	\$ 624.16	\$ 788.56
	36"(914mm)	36"(914mm)	TCRN-3636-	■	■	S	V	4	491.86	704.82	500.26	713.22	780.10	1012.26	858.62	1119.97
	42"(1067mm)	42"(1067mm)	TCRN-4242-	■	■	S	V	4	564.91	806.43	578.77	820.29	1011.97	1348.41	1132.48	1515.46
	48"(1219mm)	48"(1219mm)	TCRN-4848-	■	■	S	V	4	648.46	918.54	668.62	938.70	1277.26	1738.16	1445.74	1974.00
	54"(1372mm)	54"(1372mm)	TCRN-5454-	■	■	S	V	4	742.51	1041.15	769.81	1068.45	1575.97	2181.92	1798.40	2496.07
	60"(1524mm)	60"(1524mm)	TCRN-6060-	■	■	S	V	4	847.06	1174.26	882.34	1209.54	1908.10	2680.36	2190.46	3082.46
Base — Power Ready — No Cutout																
16"(406mm)	24"(610mm)	24"(610mm)	TCRN-2424-	■	■	S	V	1	\$397.26	\$ 553.10	\$397.26	\$ 553.10	\$ 436.62	\$ 522.64	\$ 449.10	\$ 540.37
	30"(762mm)	30"(762mm)	TCRN-3030-	■	■	S	V	1	449.31	633.71	453.09	637.49	601.65	750.58	644.16	808.56
	36"(914mm)	36"(914mm)	TCRN-3636-	■	■	S	V	1	511.86	724.82	520.26	733.22	800.10	1032.26	878.62	1139.97
	42"(1067mm)	42"(1067mm)	TCRN-4242-	■	■	S	V	1	584.91	826.43	598.77	840.29	1031.97	1368.41	1152.48	1535.46
	48"(1219mm)	48"(1219mm)	TCRN-4848-	■	■	S	V	1	668.46	938.54	688.62	958.70	1297.26	1758.16	1465.74	1994.00
20"(508mm)	24"(610mm)	24"(610mm)	TCRN-2424-	■	■	S	V	2	\$397.26	\$ 553.10	\$397.26	\$ 553.10	\$ 436.62	\$ 522.64	\$ 449.10	\$ 540.37
	30"(762mm)	30"(762mm)	TCRN-3030-	■	■	S	V	2	449.31	633.71	453.09	637.49	601.65	750.58	644.16	808.56
	36"(914mm)	36"(914mm)	TCRN-3636-	■	■	S	V	2	511.86	724.82	520.26	733.22	800.10	1032.26	878.62	1139.97
	42"(1067mm)	42"(1067mm)	TCRN-4242-	■	■	S	V	2	584.91	826.43	598.77	840.29	1031.97	1368.41	1152.48	1535.46
	48"(1219mm)	48"(1219mm)	TCRN-4848-	■	■	S	V	2	668.46	938.54	688.62	958.70	1297.26	1758.16	1465.74	1994.00
29"(737mm)	30"(762mm)	30"(762mm)	TCRN-3030-	■	■	S	V	4	\$449.31	\$ 633.71	\$453.09	\$ 637.49	\$ 601.65	\$ 750.58	\$ 644.16	\$ 808.56
	36"(914mm)	36"(914mm)	TCRN-3636-	■	■	S	V	4	511.86	724.82	520.26	733.22	800.10	1032.26	878.62	1139.97
	42"(1067mm)	42"(1067mm)	TCRN-4242-	■	■	S	V	4	584.91	826.43	598.77	840.29	1031.97	1368.41	1152.48	1535.46
	48"(1219mm)	48"(1219mm)	TCRN-4848-	■	■	S	V	4	668.46	938.54	688.62	958.70	1297.26	1758.16	1465.74	1994.00
	54"(1372mm)	54"(1372mm)	TCRN-5454-	■	■	S	V	4	762.51	1061.15	789.81	1088.45	1595.97	2201.92	1818.40	2516.07
	60"(1524mm)	60"(1524mm)	TCRN-6060-	■	■	S	V	4	867.06	1194.26	902.34	1229.54	1928.10	2700.36	2210.46	3102.46

Jive Table — Post Round Base

Square – Laminate or Wood

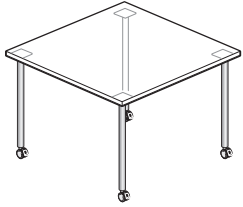

TCRQ-SNV

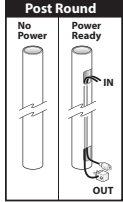

Features

- Includes 1 3/16" (30mm) thick top, leg bases, adjustable glides or casters, and hardware.
- Laminate top with knife edge or 3mm edgeband edges or wood veneer top with 3mm wood edgeband or knife edge.
- Standard table heights are 16" (406mm), 20" (508mm) and 29" (737mm).
- Bases are painted steel.
- Casters:
 - Two locking and two non-locking casters with 5/8" (16mm) adjustment.
 - Standard in black.
- Glides:
 - 5/8" (16mm) adjustment.
 - Standard in black.
- Casters and glides are not interchangeable.
- Depth and width shown in nominal dimensions.
- Ships unassembled.

Specification Tips

- Edge choice allows a flat seam between tables.
- **Specifying a cutout does not automatically include a Power Ready base.**
- Factory installed cutout is available for:
 - Specify the (F) option for a Center, Single-Sided/4 outlet Flip Top Unit
 - Specify the (J) option for a Center, Single-Sided/6 outlet Flip Top Unit
 - Specify the (M) option for a Center, Double-Sided/8 outlet Flip Top Unit
 - Specify the (Q) option for a Center, Double-Sided/12 outlet Flip Top Unit
- Power Ready Base:
 - Allows for cord management through one of the Post Extruded legs.
- **Powered leg location determined during installation.**
 - Casters and Glides:
 - Specify the (J) option for Casters on the Power Ready base (only available on 29" (737mm) high tables)
 - Specify the (K) option for Glides on the Power Ready base (available on 16" (406mm), 20" (508mm) and 29" (737mm) high tables)
 - Flip Top Unit circuit breaker plug fits Power Ready Base opening.
- **Power cord length determines the distance to building power source.**
- Separately specified:
 - Ganging Mechanism - Recommended for use with power between tables.
 - Horizontal and Vertical Wire Management
 - Power and Data Components
 - Accessories
- Refer to Specification Guide:
 - Accessory placement and compatibility.
 - Seating capacities and leg locations.
 - Information on electrical components compatible with factory cut opening.
 - Power Ready base cable capacity.
- Application may require approval of local authority having jurisdiction (AHJ); ensure compliance before placing orders and installation.

To Order, Specify:

1) Product number, including:

1 Surface Option:

- L** Laminate
- W** Wood

2 Edge Option:

Laminate:

- J** Edgeband
- F** Knife

Wood:

- K** Edgeband
- U** Knife

3 Cutout:

- N** No Cutout
- F** Center, Single-Sided/4 outlets, add **\$33.13** list
- J** Center, Single-Sided/6 outlets, add **\$33.13** list
- M** Center, Double-Sided/8 outlets, add **\$33.13** list
- Q** Center, Double-Sided/12 outlets, add **\$33.13** list

4 Base and Wire Management Option:

Base - No Power:

- C** Casters, add **\$15.60** list (29" Height Only)
- G** Glides

Base - Power Ready:

- J** Casters, add **\$15.60** list (29" Height Only)
- K** Glides

2) Laminate surface color or wood finish color.

3) Edgeband trim color (laminate only).

4) Base trim color.

Note: **\$41.60** upcharge list for Metallic trim colors.

Jive Table — Post Round Base

Square – Laminate or Wood

Height	Depth	Width	Number					Laminate A		Laminate B		Wood Group A		Wood Group B		
				①	②	③	④	J	F	J	F	K	U	K	U	
Base — No Power — No Cutout																
16"(406mm)	24"(610mm)	24"(610mm)	TCRQ-2424-	■	■	S	V	1	\$377.26	\$ 533.10	\$377.26	\$ 533.10	\$ 416.62	\$ 502.64	\$ 429.10	\$ 520.37
	30"(762mm)	30"(762mm)	TCRQ-3030-	■	■	S	V	1	429.31	613.71	433.09	617.49	581.65	730.58	624.16	788.56
	36"(914mm)	36"(914mm)	TCRQ-3636-	■	■	S	V	1	491.86	704.82	500.26	713.22	780.10	1012.26	858.62	1119.97
	42"(1067mm)	42"(1067mm)	TCRQ-4242-	■	■	S	V	1	564.91	806.43	578.77	820.29	1011.97	1348.41	1132.48	1515.46
	48"(1219mm)	48"(1219mm)	TCRQ-4848-	■	■	S	V	1	648.46	918.54	668.62	938.70	1277.26	1738.16	1445.74	1974.00
20"(508mm)	24"(610mm)	24"(610mm)	TCRQ-2424-	■	■	S	V	2	\$377.26	\$ 533.10	\$377.26	\$ 533.10	\$ 416.62	\$ 502.64	\$ 429.10	\$ 520.37
	30"(762mm)	30"(762mm)	TCRQ-3030-	■	■	S	V	2	429.31	613.71	433.09	617.49	581.65	730.58	624.16	788.56
	36"(914mm)	36"(914mm)	TCRQ-3636-	■	■	S	V	2	491.86	704.82	500.26	713.22	780.10	1012.26	858.62	1119.97
	42"(1067mm)	42"(1067mm)	TCRQ-4242-	■	■	S	V	2	564.91	806.43	578.77	820.29	1011.97	1348.41	1132.48	1515.46
	48"(1219mm)	48"(1219mm)	TCRQ-4848-	■	■	S	V	2	648.46	918.54	668.62	938.70	1277.26	1738.16	1445.74	1974.00
29"(737mm)	30"(762mm)	30"(762mm)	TCRQ-3030-	■	■	S	V	4	\$429.31	\$ 613.71	\$433.09	\$ 617.49	\$ 581.65	\$ 730.58	\$ 624.16	\$ 788.56
	36"(914mm)	36"(914mm)	TCRQ-3636-	■	■	S	V	4	491.86	704.82	500.26	713.22	780.10	1012.26	858.62	1119.97
	42"(1067mm)	42"(1067mm)	TCRQ-4242-	■	■	S	V	4	564.91	806.43	578.77	820.29	1011.97	1348.41	1132.48	1515.46
	48"(1219mm)	48"(1219mm)	TCRQ-4848-	■	■	S	V	4	648.46	918.54	668.62	938.70	1277.26	1738.16	1445.74	1974.00
	54"(1372mm)	54"(1372mm)	TCRQ-5454-	■	■	S	V	4	742.51	1041.15	769.81	1068.45	1575.97	2181.92	1798.40	2496.07
	60"(1524mm)	60"(1524mm)	TCRQ-6060-	■	■	S	V	4	847.06	1174.26	882.34	1209.54	1908.10	2680.36	2190.46	3082.46
Base — Power Ready — No Cutout																
16"(406mm)	24"(610mm)	24"(610mm)	TCRQ-2424-	■	■	S	V	1	\$397.26	\$ 553.10	\$397.26	\$ 553.10	\$ 436.62	\$ 522.64	\$ 449.10	\$ 540.37
	30"(762mm)	30"(762mm)	TCRQ-3030-	■	■	S	V	1	449.31	633.71	453.09	637.49	601.65	750.58	644.16	808.56
	36"(914mm)	36"(914mm)	TCRQ-3636-	■	■	S	V	1	511.86	724.82	520.26	733.22	800.10	1032.26	878.62	1139.97
	42"(1067mm)	42"(1067mm)	TCRQ-4242-	■	■	S	V	1	584.91	826.43	598.77	840.29	1031.97	1368.41	1152.48	1535.46
	48"(1219mm)	48"(1219mm)	TCRQ-4848-	■	■	S	V	1	668.46	938.54	688.62	958.70	1297.26	1758.16	1465.74	1994.00
20"(508mm)	24"(610mm)	24"(610mm)	TCRQ-2424-	■	■	S	V	2	\$397.26	\$ 553.10	\$397.26	\$ 553.10	\$ 436.62	\$ 522.64	\$ 449.10	\$ 540.37
	30"(762mm)	30"(762mm)	TCRQ-3030-	■	■	S	V	2	449.31	633.71	453.09	637.49	601.65	750.58	644.16	808.56
	36"(914mm)	36"(914mm)	TCRQ-3636-	■	■	S	V	2	511.86	724.82	520.26	733.22	800.10	1032.26	878.62	1139.97
	42"(1067mm)	42"(1067mm)	TCRQ-4242-	■	■	S	V	2	584.91	826.43	598.77	840.29	1031.97	1368.41	1152.48	1535.46
	48"(1219mm)	48"(1219mm)	TCRQ-4848-	■	■	S	V	2	668.46	938.54	688.62	958.70	1297.26	1758.16	1465.74	1994.00
29"(737mm)	30"(762mm)	30"(762mm)	TCRQ-3030-	■	■	S	V	4	\$449.31	\$ 633.71	\$453.09	\$ 637.49	\$ 601.65	\$ 750.58	\$ 644.16	\$ 808.56
	36"(914mm)	36"(914mm)	TCRQ-3636-	■	■	S	V	4	511.86	724.82	520.26	733.22	800.10	1032.26	878.62	1139.97
	42"(1067mm)	42"(1067mm)	TCRQ-4242-	■	■	S	V	4	584.91	826.43	598.77	840.29	1031.97	1368.41	1152.48	1535.46
	48"(1219mm)	48"(1219mm)	TCRQ-4848-	■	■	S	V	4	668.46	938.54	688.62	958.70	1297.26	1758.16	1465.74	1994.00
	54"(1372mm)	54"(1372mm)	TCRQ-5454-	■	■	S	V	4	762.51	1061.15	789.81	1088.45	1595.97	2201.92	1818.40	2516.07
	60"(1524mm)	60"(1524mm)	TCRQ-6060-	■	■	S	V	4	867.06	1194.26	902.34	1229.54	1928.10	2700.36	2210.46	3102.46

This page intentionally blank

Jive Table — Post Round Base

Pebble – Laminate or Wood



TCRP-4242-SNV (Symmetrical)

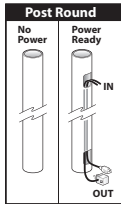

TCRP-3060-SNV (Asymmetrical)

**Features**

- Includes 1 3/16" (30mm) thick top, leg bases, adjustable glides or casters, and hardware.
- Standard table heights are 16" (406mm), 20" (508mm) and 29" (737mm).
- Laminate top with knife edge or 3mm edgeband edges or wood veneer top with 3mm wood edgeband or knife edge.
- Bases are painted steel.
- Casters:
 - Two locking and two non-locking casters with 5/8" (16mm) adjustment.
 - Standard in black.
- Glides:
 - 5/8" (16mm) adjustment.
 - Standard in black.
- Casters and glides are not interchangeable.
- Depth and width shown in nominal dimensions.
- Ships unassembled.

Specification Tips

- **Specifying a cutout does not automatically include a Power Ready base.**
- Factory installed cutout is available for:
 - Specify the (F) option for a Center, Single-Sided/4 outlet Flip Top Unit
 - Specify the (J) option for a Center, Single-Sided/6 outlet Flip Top Unit
 - Specify the (M) option for a Center, Double-Sided/8 outlet Flip Top Unit
 - Specify the (Q) option for a Center, Double-Sided/12 outlet Flip Top Unit
- Power Ready Base:
 - Allows for cord management through one of the Post Extruded legs.
- **Powered leg location determined during installation.**
 - Casters and Glides:
 - Specify the (J) option for Casters on the Power Ready base (only available on 29" (737mm) high tables)
 - Specify the (K) option for Glides on the Power Ready base (available on 16" (406mm), 20" (508mm) and 29" (737mm) high tables)
 - Flip Top Unit circuit breaker plug fits Power Ready Base opening.
- **Power cord length determines the distance to building power source.**
- Separately specified:
 - Horizontal and Vertical Wire Management
 - Power and Data Components
 - Accessories
- Refer to Specification Guide:
 - Accessory placement and compatibility.
 - Seating capacities and leg locations.
 - Information on electrical components compatible with factory cut opening.
 - Power Ready base cable capacity.
- Application may require approval of local authority having jurisdiction (AHJ); ensure compliance before placing orders and installation.

To Order, Specify:

1) Product number, including:

1 Surface Option:

- L** Laminate
- W** Wood

2 Edge Option:

Laminate:

- J** Edgeband
- F** Knife

Wood:

- K** Edgeband
- U** Knife

3 Cutout:

- N** No Cutout
- F** Center, Single-Sided/4 outlets, add **\$33.13** list
- J** Center, Single-Sided/6 outlets, add **\$33.13** list
- M** Center, Double-Sided/8 outlets, add **\$33.13** list
- Q** Center, Double-Sided/12 outlets, add **\$33.13** list

4 Base and Wire Management Option:

Base - No Power:

- C** Casters, add **\$15.60** list (29" Height Only)
- G** Glides

Base - Power Ready:

- J** Casters, add **\$15.60** list (29" Height Only)
- K** Glides

- 2) Laminate surface color or wood finish color.
- 3) Edgeband trim color (laminite only).
- 4) Base trim color.

Note: \$41.60 upcharge list for Metallic trim colors.

Jive Table — Post Round Base

Pebble – Laminate or Wood

Height	Depth	Width	Number	① ② ③ ④	Laminate A		Laminate B		Wood Group A		Wood Group B			
					J	F	J	F	K	U	K	U		
Symmetrical — Base — No Power — No Cutout														
16"(406mm)	24"(610mm)	24"(610mm)	TCRP-2424-	S	V	1	\$377.26	\$ 533.10	\$377.26	\$ 533.10	\$ 416.62	\$ 502.64	\$ 429.10	\$ 520.37
	30"(762mm)	30"(762mm)	TCRP-3030-	S	V	1	429.31	613.71	433.09	617.49	581.65	730.58	624.16	788.56
	36"(914mm)	36"(914mm)	TCRP-3636-	S	V	1	491.86	704.82	500.26	713.22	780.10	1012.26	858.62	1119.97
	42"(1067mm)	42"(1067mm)	TCRP-4242-	S	V	1	564.91	806.43	578.77	820.29	1011.97	1348.41	1132.48	1515.46
	48"(1219mm)	48"(1219mm)	TCRP-4848-	S	V	1	648.46	918.54	668.62	938.70	1277.26	1738.16	1445.74	1974.00
20"(508mm)	24"(610mm)	24"(610mm)	TCRP-2424-	S	V	2	\$377.26	\$ 533.10	\$377.26	\$ 533.10	\$ 416.62	\$ 502.64	\$ 429.10	\$ 520.37
	30"(762mm)	30"(762mm)	TCRP-3030-	S	V	2	429.31	613.71	433.09	617.49	581.65	730.58	624.16	788.56
	36"(914mm)	36"(914mm)	TCRP-3636-	S	V	2	491.86	704.82	500.26	713.22	780.10	1012.26	858.62	1119.97
	42"(1067mm)	42"(1067mm)	TCRP-4242-	S	V	2	564.91	806.43	578.77	820.29	1011.97	1348.41	1132.48	1515.46
	48"(1219mm)	48"(1219mm)	TCRP-4848-	S	V	2	648.46	918.54	668.62	938.70	1277.26	1738.16	1445.74	1974.00
29"(737mm)	30"(762mm)	30"(762mm)	TCRP-3030-	S	V	4	\$429.31	\$ 613.71	\$433.09	\$ 617.49	\$ 581.65	\$ 730.58	\$ 624.16	\$ 788.56
	36"(914mm)	36"(914mm)	TCRP-3636-	S	V	4	491.86	704.82	500.26	713.22	780.10	1012.26	858.62	1119.97
	42"(1067mm)	42"(1067mm)	TCRP-4242-	S	V	4	564.91	806.43	578.77	820.29	1011.97	1348.41	1132.48	1515.46
	48"(1219mm)	48"(1219mm)	TCRP-4848-	S	V	4	648.46	918.54	668.62	938.70	1277.26	1738.16	1445.74	1974.00
	54"(1372mm)	54"(1372mm)	TCRP-5454-	S	V	4	742.51	1041.15	769.81	1068.45	1575.97	2181.92	1798.40	2496.07
	60"(1524mm)	60"(1524mm)	TCRP-6060-	S	V	4	847.06	1174.26	882.34	1209.54	1908.10	2680.36	2190.46	3082.46
Symmetrical — Base — Power Ready — No Cutout														
16"(406mm)	24"(610mm)	24"(610mm)	TCRP-2424-	S	V	1	\$397.26	\$ 553.10	\$397.26	\$ 553.10	\$ 436.62	\$ 522.64	\$ 449.10	\$ 540.37
	30"(762mm)	30"(762mm)	TCRP-3030-	S	V	1	449.31	633.71	453.09	637.49	601.65	750.58	644.16	808.56
	36"(914mm)	36"(914mm)	TCRP-3636-	S	V	1	511.86	724.82	520.26	733.22	800.10	1032.26	878.62	1139.97
	42"(1067mm)	42"(1067mm)	TCRP-4242-	S	V	1	584.91	826.43	598.77	840.29	1031.97	1368.41	1152.48	1535.46
	48"(1219mm)	48"(1219mm)	TCRP-4848-	S	V	1	668.46	938.54	688.62	958.70	1297.26	1758.16	1465.74	1994.00
20"(508mm)	24"(610mm)	24"(610mm)	TCRP-2424-	S	V	2	\$397.26	\$ 553.10	\$397.26	\$ 553.10	\$ 436.62	\$ 522.64	\$ 449.10	\$ 540.37
	30"(762mm)	30"(762mm)	TCRP-3030-	S	V	2	449.31	633.71	453.09	637.49	601.65	750.58	644.16	808.56
	36"(914mm)	36"(914mm)	TCRP-3636-	S	V	2	511.86	724.82	520.26	733.22	800.10	1032.26	878.62	1139.97
	42"(1067mm)	42"(1067mm)	TCRP-4242-	S	V	2	584.91	826.43	598.77	840.29	1031.97	1368.41	1152.48	1535.46
	48"(1219mm)	48"(1219mm)	TCRP-4848-	S	V	2	668.46	938.54	688.62	958.70	1297.26	1758.16	1465.74	1994.00
29"(737mm)	30"(762mm)	30"(762mm)	TCRP-3030-	S	V	4	\$449.31	\$ 633.71	\$453.09	\$ 637.49	\$ 601.65	\$ 750.58	\$ 644.16	\$ 808.56
	36"(914mm)	36"(914mm)	TCRP-3636-	S	V	4	511.86	724.82	520.26	733.22	800.10	1032.26	878.62	1139.97
	42"(1067mm)	42"(1067mm)	TCRP-4242-	S	V	4	584.91	826.43	598.77	840.29	1031.97	1368.41	1152.48	1535.46
	48"(1219mm)	48"(1219mm)	TCRP-4848-	S	V	4	668.46	938.54	688.62	958.70	1297.26	1758.16	1465.74	1994.00
	54"(1372mm)	54"(1372mm)	TCRP-5454-	S	V	4	762.51	1061.15	789.81	1088.45	1595.97	2201.92	1818.40	2516.07
	60"(1524mm)	60"(1524mm)	TCRP-6060-	S	V	4	867.06	1194.26	902.34	1229.54	1928.10	2700.36	2210.46	3102.46

Jive Table — Post Round Base

Pebble – Laminate or Wood

Height	Depth	Width	Number					Laminate A		Laminate B		Wood Group A		Wood Group B				
				①	②	③	④	J	F	J	F	K	U	K	U			
Asymmetrical — Base — No Power — No Cutout																		
16"(406mm)	30"(762mm)	48"(1219mm)	TCRP-3048-	■	■	S	V	1	\$505.19	\$ 719.07	\$583.43	\$ 797.31	\$1180.65	\$1445.19	\$1337.59	\$1636.88		
		60"(1524mm)	TCRP-3060-	■	■	S	V	1	564.74	820.54	647.18	902.98	1369.24	1688.04	1560.66	1922.66		
36"(914mm)	60"(1524mm)	72"(1829mm)	TCRP-3072-	■	■	S	V	1	624.98	926.82	711.62	1013.46	1559.94	1938.32	1786.29	2217.15		
		TCRP-3660-	■	■	S	V	1	\$619.64	\$ 889.72	\$706.28	\$ 976.36	\$1543.66	\$1880.94	\$1766.54	\$2149.90			
		72"(1829mm)	TCRP-3672-	■	■	S	V	1	690.55	1007.70	782.23	1099.38	1768.31	2166.50	2032.21	2485.97		
		TCRP-3048-	■	■	S	V	2	\$505.19	\$ 719.07	\$583.43	\$ 797.31	\$1180.65	\$1445.19	\$1337.59	\$1636.88			
20"(508mm)	30"(762mm)	60"(1524mm)	TCRP-3060-	■	■	S	V	2	564.74	820.54	647.18	902.98	1369.24	1688.04	1560.66	1922.66		
		72"(1829mm)	TCRP-3072-	■	■	S	V	2	624.98	926.82	711.62	1013.46	1559.94	1938.32	1786.29	2217.15		
36"(914mm)	60"(1524mm)	TCRP-3660-	■	■	S	V	2	\$619.64	\$ 889.72	\$706.28	\$ 976.36	\$1543.66	\$1880.94	\$1766.54	\$2149.90			
		72"(1829mm)	TCRP-3672-	■	■	S	V	2	690.55	1007.70	782.23	1099.38	1768.31	2166.50	2032.21	2485.97		
		29"(737mm)	30"(762mm)	48"(1219mm)	TCRP-3048-	■	■	S	V	4	\$505.19	\$ 719.07	\$583.43	\$ 797.31	\$1180.65	\$1445.19	\$1337.59	\$1636.88
				60"(1524mm)	TCRP-3060-	■	■	S	V	4	564.74	820.54	647.18	902.98	1369.24	1688.04	1560.66	1922.66
72"(1829mm)	72"(1829mm)	TCRP-3072-	■	■	S	V	4	624.98	926.82	711.62	1013.46	1559.94	1938.32	1786.29	2217.15			
		TCRP-3660-	■	■	S	V	4	\$619.64	\$ 889.72	\$706.28	\$ 976.36	\$1543.66	\$1880.94	\$1766.54	\$2149.90			
72"(1829mm)	72"(1829mm)	TCRP-3672-	■	■	S	V	4	690.55	1007.70	782.23	1099.38	1768.31	2166.50	2032.21	2485.97			
		TCRP-4272-	■	■	S	V	4	\$756.12	\$1088.58	\$852.84	\$1185.30	\$1976.67	\$2394.67	\$2278.13	\$2754.79			
48"(1219mm)	72"(1829mm)	TCRP-4872-	■	■	S	V	4	\$821.70	\$1169.46	\$923.46	\$1271.22	\$2185.04	\$2622.85	\$2524.05	\$3023.61			
Asymmetrical — Base — Power Ready — No Cutout																		
16"(406mm)	30"(762mm)	48"(1219mm)	TCRP-3048-	■	■	S	V	1	\$525.19	\$ 739.07	\$603.43	\$ 817.31	\$1200.65	\$1465.19	\$1357.59	\$1656.88		
		60"(1524mm)	TCRP-3060-	■	■	S	V	1	584.74	840.54	667.18	922.98	1389.24	1708.04	1580.66	1942.66		
36"(914mm)	60"(1524mm)	72"(1829mm)	TCRP-3072-	■	■	S	V	1	644.98	946.82	731.62	1033.46	1579.94	1958.32	1806.29	2237.15		
		TCRP-3660-	■	■	S	V	1	\$639.64	\$ 909.72	\$726.28	\$ 996.36	\$1563.66	\$1900.94	\$1786.54	\$2169.90			
		72"(1829mm)	TCRP-3672-	■	■	S	V	1	710.55	1027.70	802.23	1119.38	1788.31	2186.50	2052.21	2505.97		
		20"(508mm)	30"(762mm)	48"(1219mm)	TCRP-3048-	■	■	S	V	2	\$525.19	\$ 739.07	\$603.43	\$ 817.31	\$1200.65	\$1465.19	\$1357.59	\$1656.88
60"(1524mm)	TCRP-3060-			■	■	S	V	2	584.74	840.54	667.18	922.98	1389.24	1708.04	1580.66	1942.66		
72"(1829mm)	72"(1829mm)	TCRP-3072-	■	■	S	V	2	644.98	946.82	731.62	1033.46	1579.94	1958.32	1806.29	2237.15			
		TCRP-3660-	■	■	S	V	2	\$639.64	\$ 909.72	\$726.28	\$ 996.36	\$1563.66	\$1900.94	\$1786.54	\$2169.90			
72"(1829mm)	72"(1829mm)	TCRP-3672-	■	■	S	V	2	710.55	1027.70	802.23	1119.38	1788.31	2186.50	2052.21	2505.97			
		29"(737mm)	30"(762mm)	48"(1219mm)	TCRP-3048-	■	■	S	V	4	\$525.19	\$ 739.07	\$603.43	\$ 817.31	\$1200.65	\$1465.19	\$1357.59	\$1656.88
60"(1524mm)	TCRP-3060-			■	■	S	V	4	584.74	840.54	667.18	922.98	1389.24	1708.04	1580.66	1942.66		
72"(1829mm)	72"(1829mm)	TCRP-3072-	■	■	S	V	4	644.98	946.82	731.62	1033.46	1579.94	1958.32	1806.29	2237.15			
		TCRP-3660-	■	■	S	V	4	\$639.64	\$ 909.72	\$726.28	\$ 996.36	\$1563.66	\$1900.94	\$1786.54	\$2169.90			
72"(1829mm)	72"(1829mm)	TCRP-3672-	■	■	S	V	4	710.55	1027.70	802.23	1119.38	1788.31	2186.50	2052.21	2505.97			
		42"(1067mm)	72"(1829mm)	TCRP-4272-	■	■	S	V	4	\$776.12	\$1108.58	\$872.84	\$1205.30	\$1996.67	\$2414.67	\$2298.13	\$2774.79	
48"(1219mm)	72"(1829mm)	TCRP-4872-	■	■	S	V	4	\$841.70	\$1189.46	\$943.46	\$1291.22	\$2205.04	\$2642.85	\$2544.05	\$3043.61			

This page intentionally blank

Jive Table — Post Round Base

Rectangle – Laminate or Wood

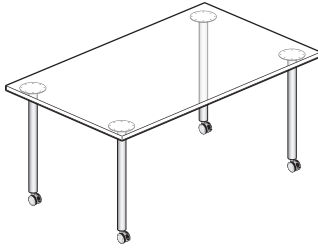

TCRA-SNV

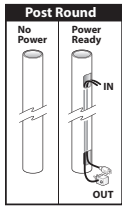
**Features**

- Includes 1 3/16" (30mm) thick top, leg bases, adjustable glides or casters, and hardware.
- Standard table heights are 16" (406mm), 20" (508mm) and 29" (737mm).
- Laminate top with knife edge or 3mm edgeband edges or wood veneer top with 3mm wood edgeband or knife edge.
- Bases are painted steel.
- Casters:
 - Two locking and two non-locking casters with 5/8" (16mm) adjustment.
 - Standard in black.
- Glides:
 - 5/8" (16mm) adjustment.
 - Standard in black.
- Casters and glides are not interchangeable.
- Depth and width shown in nominal dimensions.
- Ships unassembled.

Specification Tips

- Edge choice allows a flat seam between tables.
- **Specifying a cutout does not automatically include a Power Ready base.**
- Factory installed cutout is available for:
 - Specify the (F) option for a Center, Single-Sided/4 outlet Flip Top Unit
 - Specify the (J) option for a Center, Single-Sided/6 outlet Flip Top Unit
 - Specify the (M) option for a Center, Double-Sided/8 outlet Flip Top Unit
 - Specify the (Q) option for a Center, Double-Sided/12 outlet Flip Top Unit
- Power Ready Base:
 - Allows for cord management through one of the Post Extruded legs.
- **Powered leg location determined during installation.**
 - Casters and Glides:
 - Specify the (J) option for Casters on the Power Ready base (only available on 29" (737mm) high tables)
 - Specify the (K) option for Glides on the Power Ready base (available on 16" (406mm), 20" (508mm) and 29" (737mm) high tables)
 - Flip Top Unit circuit breaker plug fits Power Ready Base opening.
- **Power cord length determines the distance to building power source.**
- Separately specified:
 - Ganging Mechanism - Recommended for use with power between tables.
 - Horizontal and Vertical Wire Management
 - Power and Data Components
 - Accessories
- Refer to Specification Guide:
 - Accessory placement and compatibility.
 - Seating capacities and leg locations.
 - Information on electrical components compatible with factory cut opening.
 - Power Ready base cable capacity.
- Application may require approval of local authority having jurisdiction (AHJ); ensure compliance before placing orders and installation.

To Order, Specify:

1) Product number, including:

1 Surface Option:

- L** Laminate
- W** Wood

2 Edge Option:

Laminate:

- J** Edgeband
- F** Knife

Wood:

- K** Edgeband
- U** Knife

3 Cutout:

- N** No Cutout
- F** Center, Single-Sided/4 outlets, add **\$33.13** list
- J** Center, Single-Sided/6 outlets, add **\$33.13** list
- M** Center, Double-Sided/8 outlets, add **\$33.13** list
- Q** Center, Double-Sided/12 outlets, add **\$33.13** list

4 Base and Wire Management Option:

Base - No Power:

- C** Casters, add **\$15.60** list (29" Height Only)
- G** Glides

Base - Power Ready:

- J** Casters, add **\$15.60** list (29" Height Only)
- K** Glides

2) Laminate surface color or wood finish color.

3) Edgeband trim color (laminated only).

4) Base trim color.

Note: \$41.60 upcharge list for Metallic trim colors.

Jive Table — Post Round Base

Rectangle – Laminate or Wood

Height	Depth	Width	Number					Laminate A		Laminate B		Wood Group A		Wood Group B			
				①	②	③	④	J	F	J	F	K	U	K	U		
Base — No Power — No Cutout																	
16"(406mm)	30"(762mm)	48"(1219mm)	TCRA-3048-		S	V	1	\$505.19	\$ 719.07	\$583.43	\$ 797.31	\$1180.65	\$1445.19	\$1337.59	\$1636.88		
		54"(1372mm)	TCRA-3054-		S	V	1	534.88	769.20	615.22	849.54	1274.68	1565.69	1448.80	1778.68		
		60"(1524mm)	TCRA-3060-		S	V	1	564.74	820.54	647.18	902.98	1369.24	1688.04	1560.66	1922.66		
	36"(914mm)	60"(1524mm)	TCRA-3660-		S	V	1	\$619.64	\$ 889.72	\$706.28	\$ 976.36	\$1543.66	\$1880.94	\$1766.54	\$2149.90		
		72"(1829mm)	TCRA-3672-		S	V	1	690.55	1007.70	782.23	1099.38	1768.31	2166.50	2032.21	2485.97		
20"(508mm)	30"(762mm)	48"(1219mm)	TCRA-3048-		S	V	2	\$505.19	\$ 719.07	\$583.43	\$ 797.31	\$1180.65	\$1445.19	\$1337.59	\$1636.88		
		54"(1372mm)	TCRA-3054-		S	V	2	534.88	769.20	615.22	849.54	1274.68	1565.69	1448.80	1778.68		
		60"(1524mm)	TCRA-3060-		S	V	2	564.74	820.54	647.18	902.98	1369.24	1688.04	1560.66	1922.66		
	36"(914mm)	60"(1524mm)	TCRA-3660-		S	V	2	\$619.64	\$ 889.72	\$706.28	\$ 976.36	\$1543.66	\$1880.94	\$1766.54	\$2149.90		
		72"(1829mm)	TCRA-3672-		S	V	2	690.55	1007.70	782.23	1099.38	1768.31	2166.50	2032.21	2485.97		
29"(737mm)	18"(457mm)	48"(1219mm)	TCRA-1848-		S	V	4	\$416.74	N/A	\$488.26	N/A	\$ 899.70	N/A	\$1005.91	N/A		
		54"(1372mm)	TCRA-1854-		S	V	4	435.75	N/A	508.53	N/A	959.79	N/A	1077.08	N/A		
		60"(1524mm)	TCRA-1860-		S	V	4	454.94	N/A	528.98	N/A	1020.40	N/A	1148.90	N/A		
		66"(1676mm)	TCRA-1866-		S	V	4	474.30	N/A	549.60	N/A	1081.54	N/A	1221.36	N/A		
		72"(1829mm)	TCRA-1872-		S	V	4	493.83	N/A	570.39	N/A	1143.21	N/A	1294.45	N/A		
	24"(610mm)	36"(914mm)	48"(1219mm)	TCRA-2436-		S	V	4	\$412.78	\$ 576.62	\$484.30	\$ 648.14	\$ 887.64	\$1087.43	\$ 991.27	\$1215.71	
			42"(1067mm)	TCRA-2442-		S	V	4	436.79	618.50	509.99	691.70	963.64	1186.57	1081.19	1332.37	
		48"(1219mm)	42"(1067mm)	TCRA-2448-		S	V	4	460.97	661.59	535.85	736.47	1040.18	1287.57	1171.75	1451.21	
			54"(1372mm)	TCRA-2454-		S	V	4	485.32	705.87	561.88	782.43	1117.23	1390.43	1262.94	1572.23	
		60"(1524mm)	42"(1067mm)	TCRA-2460-		S	V	4	509.84	751.36	588.08	829.60	1194.82	1495.14	1354.78	1695.42	
			48"(1219mm)	TCRA-2466-		S	V	4	534.54	798.05	614.46	877.97	1272.93	1601.71	1447.26	1820.79	
		72"(1829mm)	42"(1067mm)	TCRA-2472-		S	V	4	559.40	845.94	641.00	927.54	1351.57	1710.14	1540.37	1948.34	
			48"(1219mm)	TCRA-2478-		S	V	4	584.26	892.82	666.86	962.42	1430.49	1801.02	1620.49	2078.46	
		30"(762mm)	36"(914mm)	48"(1219mm)	TCRA-3036-		S	V	4	\$446.34	\$ 622.40	\$520.38	\$ 696.44	\$ 994.17	\$1209.77	\$1117.07	\$1359.80
				54"(1372mm)	TCRA-3042-		S	V	4	475.68	670.13	551.82	746.27	1087.14	1326.55	1227.01	1497.25
60"(1524mm)	TCRA-3048-				S	V	4	505.19	719.07	583.43	797.31	1180.65	1445.19	1337.59	1636.88		
66"(1676mm)	TCRA-3054-				S	V	4	534.88	769.20	615.22	849.54	1274.68	1565.69	1448.80	1778.68		
72"(1829mm)	TCRA-3060-				S	V	4	564.74	820.54	647.18	902.98	1369.24	1688.04	1560.66	1922.66		
36"(914mm)	60"(1524mm)	48"(1219mm)	TCRA-3072-		S	V	4	624.98	926.82	711.62	1013.46	1559.94	1938.32	1786.29	2217.15		
		60"(1524mm)	TCRA-3660-		S	V	4	\$619.64	\$ 889.72	\$706.28	\$ 976.36	\$1543.66	\$1880.94	\$1766.54	\$2149.90		
		66"(1676mm)	TCRA-3666-		S	V	4	655.01	948.11	744.17	1037.27	1655.72	2022.79	1899.05	2316.85		
		72"(1829mm)	TCRA-3672-		S	V	4	690.55	1007.70	782.23	1099.38	1768.31	2166.50	2032.21	2485.97		
		72"(1829mm)	TCRA-3678-		S	V	4	715.41	1054.58	807.09	1146.26	1843.17	2301.29	2157.12	2633.04		
42"(1067mm)	60"(1524mm)	48"(1219mm)	TCRA-4260-		S	V	4	\$674.54	\$ 958.90	\$765.38	\$1049.74	\$1718.08	\$2073.84	\$1972.42	\$2377.14		
		60"(1524mm)	TCRA-4272-		S	V	4	756.12	1088.58	852.84	1185.30	1976.67	2394.67	2278.13	2754.79		
		72"(1829mm)	TCRA-4278-		S	V	4	780.98	1135.46	877.70	1228.18	2057.59	2515.59	2399.04	2897.34		
48"(1219mm)	72"(1829mm)	TCRA-4872-		S	V	4	\$821.70	\$1169.46	\$923.46	\$1271.22	\$2185.04	\$2622.85	\$2524.05	\$3023.61			

Jive Table — Post Round Base

Rectangle – Laminate or Wood

Height	Depth	Width	Number					Laminate A		Laminate B		Wood Group A		Wood Group B				
				①	②	③	④	J	F	J	F	K	U	K	U			
Base — Power Ready — No Cutout																		
16"(406mm)	30"(762mm)	48"(1219mm)	TCRA-3048-	■	■	S	V	1	\$525.19	\$ 739.07	\$603.43	\$ 817.31	\$1200.65	\$1465.19	\$1357.59	\$1656.88		
		54"(1372mm)	TCRA-3054-	■	■	S	V	1	554.88	789.20	635.22	869.54	1294.68	1585.69	1468.80	1798.68		
		60"(1524mm)	TCRA-3060-	■	■	S	V	1	584.74	840.54	667.18	922.98	1389.24	1708.04	1580.66	1942.66		
	36"(914mm)	60"(1524mm)	TCRA-3660-	■	■	S	V	1	\$639.64	\$ 909.72	\$726.28	\$ 996.36	\$1563.66	\$1900.94	\$1786.54	\$2169.90		
		72"(1829mm)	TCRA-3672-	■	■	S	V	1	710.55	1027.70	802.23	1119.38	1788.31	2186.50	2052.21	2505.97		
20"(508mm)	30"(762mm)	48"(1219mm)	TCRA-3048-	■	■	S	V	2	\$525.19	\$ 739.07	\$603.43	\$ 817.31	\$1200.65	\$1465.19	\$1357.59	\$1656.88		
		54"(1372mm)	TCRA-3054-	■	■	S	V	2	554.88	789.20	635.22	869.54	1294.68	1585.69	1468.80	1798.68		
		60"(1524mm)	TCRA-3060-	■	■	S	V	2	584.74	840.54	667.18	922.98	1389.24	1708.04	1580.66	1942.66		
	36"(914mm)	60"(1524mm)	TCRA-3660-	■	■	S	V	2	\$639.64	\$ 909.72	\$726.28	\$ 996.36	\$1563.66	\$1900.94	\$1786.54	\$2169.90		
		72"(1829mm)	TCRA-3672-	■	■	S	V	2	710.55	1027.70	802.23	1119.38	1788.31	2186.50	2052.21	2505.97		
29"(737mm)	18"(457mm)	48"(1219mm)	TCRA-1848-	■	■	S	V	4	\$436.74	N/A	\$508.26	N/A	\$ 919.70	N/A	\$1025.91	N/A		
		54"(1372mm)	TCRA-1854-	■	■	S	V	4	455.75	N/A	528.53	N/A	979.79	N/A	1097.08	N/A		
		60"(1524mm)	TCRA-1860-	■	■	S	V	4	474.94	N/A	548.98	N/A	1040.40	N/A	1168.90	N/A		
		66"(1676mm)	TCRA-1866-	■	■	S	V	4	494.30	N/A	569.60	N/A	1101.54	N/A	1241.36	N/A		
		72"(1829mm)	TCRA-1872-	■	■	S	V	4	513.83	N/A	590.39	N/A	1163.21	N/A	1314.45	N/A		
	24"(610mm)	36"(914mm)	42"(1067mm)	TCRA-2442-	■	■	S	V	4	456.79	638.50	529.99	711.70	983.64	1206.57	1101.19	1352.37	
			48"(1219mm)	TCRA-2448-	■	■	S	V	4	480.97	681.59	555.85	756.47	1060.18	1307.57	1191.75	1471.21	
			54"(1372mm)	TCRA-2454-	■	■	S	V	4	505.32	725.87	581.88	802.43	1137.23	1410.43	1282.94	1592.23	
			60"(1524mm)	TCRA-2460-	■	■	S	V	4	529.84	771.36	608.08	849.60	1214.82	1515.14	1374.78	1715.42	
			66"(1676mm)	TCRA-2466-	■	■	S	V	4	554.54	818.05	634.46	897.97	1292.93	1621.71	1467.26	1840.79	
			72"(1829mm)	TCRA-2472-	■	■	S	V	4	579.40	865.94	661.00	947.54	1371.57	1730.14	1560.37	1968.34	
		30"(762mm)	36"(914mm)	42"(1067mm)	TCRA-3036-	■	■	S	V	4	\$466.34	\$ 642.40	\$540.38	\$ 716.44	\$1014.17	\$1229.77	\$1137.07	\$1379.80
				48"(1219mm)	TCRA-3048-	■	■	S	V	4	525.19	739.07	603.43	817.31	1200.65	1465.19	1357.59	1656.88
				54"(1372mm)	TCRA-3054-	■	■	S	V	4	554.88	789.20	635.22	869.54	1294.68	1585.69	1468.80	1798.68
				60"(1524mm)	TCRA-3060-	■	■	S	V	4	584.74	840.54	667.18	922.98	1389.24	1708.04	1580.66	1942.66
				66"(1676mm)	TCRA-3066-	■	■	S	V	4	675.01	968.11	764.17	1057.27	1675.72	2042.79	1919.05	2336.85
				72"(1829mm)	TCRA-3072-	■	■	S	V	4	644.98	946.82	731.62	1033.46	1579.94	1958.32	1806.29	2237.15
36"(914mm)	60"(1524mm)	66"(1676mm)	TCRA-3666-	■	■	S	V	4	\$639.64	\$ 909.72	\$726.28	\$ 996.36	\$1563.66	\$1900.94	\$1786.54	\$2169.90		
		72"(1829mm)	TCRA-3672-	■	■	S	V	4	710.55	1027.70	802.23	1119.38	1788.31	2186.50	2052.21	2505.97		
	42"(1067mm)	60"(1524mm)	72"(1829mm)	TCRA-4260-	■	■	S	V	4	\$694.54	\$ 978.90	\$785.38	\$1069.74	\$1738.08	\$2093.84	\$1992.42	\$2397.14	
48"(1219mm)	72"(1829mm)		TCRA-4272-	■	■	S	V	4	776.12	1108.58	872.84	1205.30	1996.67	2414.67	2298.13	2774.79		
			TCRA-4872-	■	■	S	V	4	\$841.70	\$1189.46	\$943.46	\$1291.22	\$2205.04	\$2642.85	\$2544.05	\$3043.61		

Jive Table — Post Round Base

Racetrack – Laminate or Wood

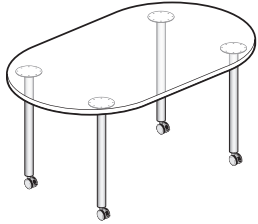

TCRT-SNV

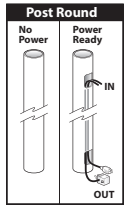

Features

- Includes 1 3/16" (30mm) thick top, leg bases, adjustable glides or casters, and hardware.
- Standard table heights are 16" (406mm), 20" (508mm) and 29" (737mm).
- Laminate top with knife edge or 3mm edgeband edges or wood veneer top with 3mm wood edgeband or knife edge.
- Bases are painted steel.
- Casters:
 - Two locking and two non-locking casters with 5/8" (16mm) adjustment.
 - Standard in black.
- Glides:
 - 5/8" (16mm) adjustment.
 - Standard in black.
- Casters and glides are not interchangeable.
- Depth and width shown in nominal dimensions.
- Ships unassembled.

Specification Tips

- **Specifying a cutout does not automatically include a Power Ready base.**
- Factory installed cutout is available for:
 - Specify the (F) option for a Center, Single-Sided/4 outlet Flip Top Unit
 - Specify the (J) option for a Center, Single-Sided/6 outlet Flip Top Unit
 - Specify the (M) option for a Center, Double-Sided/8 outlet Flip Top Unit
 - Specify the (Q) option for a Center, Double-Sided/12 outlet Flip Top Unit
- Power Ready Base:
 - Allows for cord management through one of the Post Extruded legs.
- **Powered leg location determined during installation.**
 - Casters and Glides:
 - Specify the (J) option for Casters on the Power Ready base (only available on 29" (737mm) high tables)
 - Specify the (K) option for Glides on the Power Ready base (available on 16" (406mm), 20" (508mm) and 29" (737mm) high tables)
 - Flip Top Unit circuit breaker plug fits Power Ready Base opening.
- **Power cord length determines the distance to building power source.**
- Separately specified:
 - Horizontal and Vertical Wire Management
 - Power and Data Components
 - Accessories
- Refer to Specification Guide:
 - Accessory placement and compatibility.
 - Seating capacities and leg locations.
 - Information on electrical components compatible with factory cut opening.
 - Power Ready base cable capacity.
- Application may require approval of local authority having jurisdiction (AHJ); ensure compliance before placing orders and installation.

To Order, Specify:

1) Product number, including:

1 Surface Option:

- L** Laminate
- W** Wood

2 Edge Option:

Laminate:

- J** Edgeband
- F** Knife

Wood:

- K** Edgeband
- U** Knife

3 Cutout:

- N** No Cutout
- F** Center, Single-Sided/4 outlets, add **\$33.13** list
- J** Center, Single-Sided/6 outlets, add **\$33.13** list
- M** Center, Double-Sided/8 outlets, add **\$33.13** list
- Q** Center, Double-Sided/12 outlets, add **\$33.13** list

4 Base and Wire Management Option:

Base - No Power:

- C** Casters, add **\$15.60** list (29" Height Only)
- G** Glides

Base - Power Ready:

- J** Casters, add **\$15.60** list (29" Height Only)
- K** Glides

2) Laminate surface color or wood finish color.

3) Edgeband trim color (laminate only).

4) Base trim color.

Note: **\$41.60** upcharge list for Metallic trim colors.

Jive Table — Post Round Base

Racetrack – Laminate or Wood

Height	Depth	Width	Number					Laminate A		Laminate B		Wood Group A		Wood Group B	
				①	②	③	④	J	F	J	F	K	U	K	U
Base — No Power — No Cutout															
16"(406mm)	30"(762mm)	48"(1219mm)	TCRT-3048-		S	V	1	\$505.19	\$ 719.07	\$583.43	\$ 797.31	\$1180.65	\$1445.19	\$1337.59	\$1636.88
		60"(1524mm)	TCRT-3060-		S	V	1	564.74	820.54	647.18	902.98	1369.24	1688.04	1560.66	1922.66
		72"(1829mm)	TCRT-3072-		S	V	1	624.98	926.82	711.62	1013.46	1559.94	1938.32	1786.29	2217.15
	36"(914mm)	60"(1524mm)	TCRT-3660-		S	V	1	\$619.64	\$ 889.72	\$706.28	\$ 976.36	\$1543.66	\$1880.94	\$1766.54	\$2149.90
		72"(1829mm)	TCRT-3672-		S	V	1	690.55	1007.70	782.23	1099.38	1768.31	2166.50	2032.21	2485.97
		48"(1219mm)	TCRT-4872-		S	V	4	\$821.70	\$1169.46	\$923.46	\$1271.22	\$2185.04	\$2622.85	\$2524.05	\$3023.61
20"(508mm)	30"(762mm)	48"(1219mm)	TCRT-3048-		S	V	2	\$505.19	\$ 719.07	\$583.43	\$ 797.31	\$1180.65	\$1445.19	\$1337.59	\$1636.88
		60"(1524mm)	TCRT-3060-		S	V	2	564.74	820.54	647.18	902.98	1369.24	1688.04	1560.66	1922.66
		72"(1829mm)	TCRT-3072-		S	V	2	624.98	926.82	711.62	1013.46	1559.94	1938.32	1786.29	2217.15
	36"(914mm)	60"(1524mm)	TCRT-3660-		S	V	2	\$619.64	\$ 889.72	\$706.28	\$ 976.36	\$1543.66	\$1880.94	\$1766.54	\$2149.90
		72"(1829mm)	TCRT-3672-		S	V	2	690.55	1007.70	782.23	1099.38	1768.31	2166.50	2032.21	2485.97
		48"(1219mm)	TCRT-4872-		S	V	4	\$821.70	\$1169.46	\$923.46	\$1271.22	\$2185.04	\$2622.85	\$2524.05	\$3023.61
29"(737mm)	30"(762mm)	48"(1219mm)	TCRT-3048-		S	V	4	\$505.19	\$ 719.07	\$583.43	\$ 797.31	\$1180.65	\$1445.19	\$1337.59	\$1636.88
		60"(1524mm)	TCRT-3060-		S	V	4	564.74	820.54	647.18	902.98	1369.24	1688.04	1560.66	1922.66
		72"(1829mm)	TCRT-3072-		S	V	4	624.98	926.82	711.62	1013.46	1559.94	1938.32	1786.29	2217.15
	36"(914mm)	60"(1524mm)	TCRT-3660-		S	V	4	\$619.64	\$ 889.72	\$706.28	\$ 976.36	\$1543.66	\$1880.94	\$1766.54	\$2149.90
		72"(1829mm)	TCRT-3672-		S	V	4	690.55	1007.70	782.23	1099.38	1768.31	2166.50	2032.21	2485.97
		42"(1067mm)	TCRT-4272-		S	V	4	\$756.12	\$1088.58	\$852.84	\$1185.30	\$1976.67	\$2394.67	\$2278.13	\$2754.79
Base — Power Ready — No Cutout															
16"(406mm)	30"(762mm)	48"(1219mm)	TCRT-3048-		S	V	1	\$525.19	\$ 739.07	\$603.43	\$ 817.31	\$1200.65	\$1465.19	\$1357.59	\$1656.88
		60"(1524mm)	TCRT-3060-		S	V	1	584.74	840.54	667.18	922.98	1389.24	1708.04	1580.66	1942.66
		72"(1829mm)	TCRT-3072-		S	V	1	644.98	946.82	731.62	1033.46	1579.94	1958.32	1806.29	2237.15
	36"(914mm)	60"(1524mm)	TCRT-3660-		S	V	1	\$639.64	\$ 909.72	\$726.28	\$ 996.36	\$1563.66	\$1900.94	\$1786.54	\$2169.90
		72"(1829mm)	TCRT-3672-		S	V	1	710.55	1027.70	802.23	1119.38	1788.31	2186.50	2052.21	2505.97
		48"(1219mm)	TCRT-4872-		S	V	4	\$841.70	\$1189.46	\$943.46	\$1291.22	\$2205.04	\$2642.85	\$2544.05	\$3043.61
20"(508mm)	30"(762mm)	48"(1219mm)	TCRT-3048-		S	V	2	\$525.19	\$ 739.07	\$603.43	\$ 817.31	\$1200.65	\$1465.19	\$1357.59	\$1656.88
		60"(1524mm)	TCRT-3060-		S	V	2	584.74	840.54	667.18	922.98	1389.24	1708.04	1580.66	1942.66
		72"(1829mm)	TCRT-3072-		S	V	2	644.98	946.82	731.62	1033.46	1579.94	1958.32	1806.29	2237.15
	36"(914mm)	60"(1524mm)	TCRT-3660-		S	V	2	\$639.64	\$ 909.72	\$726.28	\$ 996.36	\$1563.66	\$1900.94	\$1786.54	\$2169.90
		72"(1829mm)	TCRT-3672-		S	V	2	710.55	1027.70	802.23	1119.38	1788.31	2186.50	2052.21	2505.97
		48"(1219mm)	TCRT-4872-		S	V	4	\$841.70	\$1189.46	\$943.46	\$1291.22	\$2205.04	\$2642.85	\$2544.05	\$3043.61
29"(737mm)	30"(762mm)	48"(1219mm)	TCRT-3048-		S	V	4	\$525.19	\$ 739.07	\$603.43	\$ 817.31	\$1200.65	\$1465.19	\$1357.59	\$1656.88
		60"(1524mm)	TCRT-3060-		S	V	4	584.74	840.54	667.18	922.98	1389.24	1708.04	1580.66	1942.66
		72"(1829mm)	TCRT-3072-		S	V	4	644.98	946.82	731.62	1033.46	1579.94	1958.32	1806.29	2237.15
	36"(914mm)	60"(1524mm)	TCRT-3660-		S	V	4	\$639.64	\$ 909.72	\$726.28	\$ 996.36	\$1563.66	\$1900.94	\$1786.54	\$2169.90
		72"(1829mm)	TCRT-3672-		S	V	4	710.55	1027.70	802.23	1119.38	1788.31	2186.50	2052.21	2505.97
		42"(1067mm)	TCRT-4272-		S	V	4	\$776.12	\$1108.58	\$872.84	\$1205.30	\$1996.67	\$2414.67	\$2298.13	\$2774.79

Jive Table — Post Round Base

Trapezoid – Laminate or Wood

Height	Depth	Width	Number	Laminate A		Laminate B		Wood Group A		Wood Group B				
				①	②	③	④	J	F	J	F	K	U	K
Base — No Power — No Cutout														
29"(737mm)	24"(610mm)	48"(1219mm)	TCTP-2448-	S	V	4	\$468.29	\$ 668.91	\$471.65	\$ 672.27	\$ 614.76	\$ 862.15	\$ 656.05	\$ 935.51
		54"(1372mm)	TCTP-2454-	S	V	4	492.64	713.19	497.68	718.23	691.81	965.01	747.24	1056.53
		60"(1524mm)	TCTP-2460-	S	V	4	517.16	758.68	523.88	765.40	769.40	1069.72	839.08	1179.72
		66"(1676mm)	TCTP-2466-	S	V	4	541.86	805.37	550.26	813.77	847.51	1176.29	931.56	1305.09
		72"(1829mm)	TCTP-2472-	S	V	4	566.72	853.26	576.80	863.34	926.15	1284.72	1024.67	1432.64
30"(762mm)	60"(1524mm)	TCTP-3060-	S	V	4	\$572.06	\$ 827.86	\$582.98	\$ 838.78	\$ 943.82	\$1262.62	\$1044.96	\$1406.96	
		TCTP-3066-	S	V	4	602.09	880.40	615.11	893.42	1038.91	1386.83	1157.45	1553.12	
		TCTP-3072-	S	V	4	632.30	934.14	647.42	949.26	1134.52	1512.90	1270.59	1701.45	
36"(914mm)	84"(2134mm)	TCTP-3684-	S	V	4	\$769.47	\$1137.80	\$794.67	\$1163.00	\$1569.64	\$2034.06	\$1784.73	\$2315.05	
Base — Power Ready — No Cutout														
29"(737mm)	24"(610mm)	48"(1219mm)	TCTP-2448-	S	V	4	\$488.29	\$ 688.91	\$491.65	\$ 692.27	\$ 634.76	\$ 882.15	\$ 676.05	\$ 955.51
		54"(1372mm)	TCTP-2454-	S	V	4	512.64	733.19	517.68	738.23	711.81	985.01	767.24	1076.53
		60"(1524mm)	TCTP-2460-	S	V	4	537.16	778.68	543.88	785.40	789.40	1089.72	859.08	1199.72
		66"(1676mm)	TCTP-2466-	S	V	4	561.86	825.37	570.26	833.77	867.51	1196.29	951.56	1325.09
		72"(1829mm)	TCTP-2472-	S	V	4	586.72	873.26	596.80	883.34	946.15	1304.72	1044.67	1452.64
30"(762mm)	60"(1524mm)	TCTP-3060-	S	V	4	\$592.06	\$ 847.86	\$602.98	\$ 858.78	\$ 963.82	\$1282.62	\$1064.96	\$1426.96	
		TCTP-3066-	S	V	4	622.09	900.40	635.11	913.42	1058.91	1406.83	1177.45	1573.12	
		TCTP-3072-	S	V	4	652.30	954.14	667.42	969.26	1154.52	1532.90	1290.59	1721.45	
36"(914mm)	84"(2134mm)	TCTP-3684-	S	V	4	\$789.47	\$1157.80	\$814.67	\$1183.00	\$1589.64	\$2054.06	\$1804.73	\$2335.05	

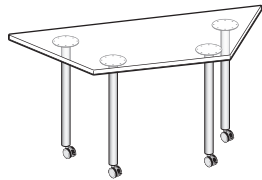

TCTP-SNV

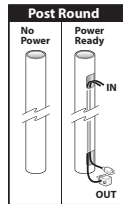

Features

- Includes 1 3/16"(30mm) thick top, leg bases, adjustable glides or casters, and hardware.
- Standard table height is 29"(737mm).
- Laminate top with knife edge or 3mm edgeband edges or wood veneer top with 3mm wood edgeband or knife edge.
- Bases are painted steel.
- Casters:
 - Two locking and two non-locking casters with 5/8"(16mm) adjustment.
 - Standard in black.
- Glides:
 - 5/8"(16mm) adjustment.
 - Standard in black.
- Casters and glides are not interchangeable.
- Depth and width shown in nominal dimensions.
- Ships unassembled.

Specification Tips

- Edge choice allows a flat seam between tables.
- **Specifying a cutout does not automatically include a Power Ready base.**
- Factory installed cutout is available for:
 - Specify the (F) option for a Center, Single-Sided/4 outlet Flip Top Unit
 - Specify the (J) option for a Center, Single-Sided/6 outlet Flip Top Unit
- Power Ready Base:
 - Allows for cord management through one of the Post Extruded legs.
- **Powered leg location determined during installation.**
 - Casters and Glides:
 - Specify the (J) option for Casters on the Power Ready base (only available on 29"(737mm) high tables)
 - Specify the (K) option for Glides on the Power Ready base (available on 29"(737mm) high tables)
 - Flip Top Unit circuit breaker plug fits Power Ready Base opening.
- **Power cord length determines the distance to building power source.**
- Separately specified:
 - Ganging Mechanism - Recommended for use with power between tables.
 - Horizontal and Vertical Wire Management
 - Power and Data Components
 - Accessories
- Refer to Specification Guide:
 - Accessory placement and compatibility.
 - Seating capacities and leg locations.
 - Information on electrical components compatible with factory cut opening.
 - Power Ready base cable capacity.
- Application may require approval of local authority having jurisdiction (AHJ); ensure compliance before placing orders and installation.

To Order, Specify:

1) Product number, including:

① Surface Option:

- L** Laminate
- W** Wood

② Edge Option:

Laminate:

- J** Edgeband
- F** Knife

Wood:

- K** Edgeband
- U** Knife

③ Cutout:

- N** No Cutout
- F** Center, Single-Sided/4 outlets, add \$33.13 list
- J** Center, Single-Sided/6 outlets, add \$33.13 list

④ Base and Wire Management Option:

Base - No Power:

- C** Casters, add \$15.60 list (29" Height Only)
- G** Glides

Base - Power Ready:

- J** Casters, add \$15.60 list (29" Height Only)
- K** Glides

- 2) Laminate surface color or wood finish color.
- 3) Edgeband trim color (laminates only).
- 4) Base trim color.

Note: \$41.60 upcharge list for Metallic trim colors.

Jive Table — Post Round Base

Crescent – Laminate or Wood

Depth	Width	Number	① ② ③ ④	Laminate A		Laminate B		Wood Group A		Wood Group B	
				J	F	J	F	K	U	K	U
Base — No Power — No Cutout											
24"(610mm)	60"(1524mm)	TCBN-2460-	■ ■ S ■ V ■ 4	\$539.21	\$ 780.73	\$545.93	\$ 787.45	\$ 791.45	\$1091.77	\$ 861.13	\$1201.77
30"(762mm)	72"(1829mm)	TCBN-3072-	■ ■ S ■ V ■ 4	654.35	956.19	669.47	971.31	1156.57	1534.95	1292.64	1723.50
36"(914mm)	84"(2134mm)	TCBN-3684-	■ ■ S ■ V ■ 4	791.52	1159.85	816.72	1185.05	1591.69	2056.11	1806.78	2337.10
Base — Power Ready — No Cutout											
24"(610mm)	60"(1524mm)	TCBN-2460-	■ ■ S ■ V ■ 4	\$559.21	\$ 800.73	\$565.93	\$ 807.45	\$ 811.45	\$1111.77	\$ 881.13	\$1221.77
30"(762mm)	72"(1829mm)	TCBN-3072-	■ ■ S ■ V ■ 4	674.35	976.19	689.47	991.31	1176.57	1554.95	1312.64	1743.50
36"(914mm)	84"(2134mm)	TCBN-3684-	■ ■ S ■ V ■ 4	811.52	1179.85	836.72	1205.05	1611.69	2076.11	1826.78	2357.10

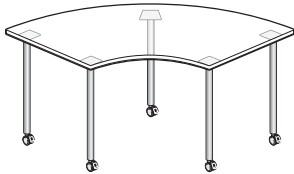

TCBN-SNV

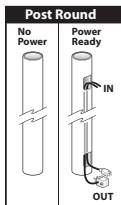

Features

- Includes 1 3/16"(30mm) thick top, leg bases, adjustable glides or casters, and hardware.
- Standard table height is 29"(737mm).
- Laminate top with knife edge or 3mm edgeband edges or wood veneer top with 3mm wood edgeband or knife edge.
- Bases are painted steel.
- Casters:
 - Two locking and two non-locking casters with 5/8"(16mm) adjustment.
 - Standard in black.
- Glides:
 - 5/8"(16mm) adjustment.
 - Standard in black.
- Casters and glides are not interchangeable.
- Depth and width shown in nominal dimensions.
- Ships unassembled.

Specification Tips

- Edge choice allows a flat seam between tables.
- Specifying a cutout does not automatically include a Power Ready base.**
- Factory installed cutout is available for:
 - Specify the (F) option for a Center, Single-Sided/4 outlet Flip Top Unit
 - Specify the (J) option for a Center, Single-Sided/6 outlet Flip Top Unit
- Power Ready Base:
 - Allows for cord management through one of the Post Extruded legs.
- Powered leg location determined during installation.**
 - Casters and Glides:
 - Specify the (J) option for Casters on the Power Ready base (only available on 29"(737mm) high tables)
 - Specify the (K) option for Glides on the Power Ready base (available on 29"(737mm) high tables)
 - Flip Top Unit circuit breaker plug fits Power Ready Base opening.
- Power cord length determines the distance to building power source.**
- Separately specified:
 - Ganging Mechanism - Recommended for use with power between tables.
 - Horizontal and Vertical Wire Management
 - Power and Data Components
 - Accessories
- Refer to Specification Guide:
 - Accessory placement and compatibility.
 - Seating capacities and leg locations.
 - Information on electrical components compatible with factory cut opening.
 - Power Ready base cable capacity.
- Application may require approval of local authority having jurisdiction (AHJ); ensure compliance before placing orders and installation.

To Order, Specify:

- Product number, including:

① Surface Option:

- Laminate
- Wood

② Edge Option:

Laminate:

- Edgeband
- Knife

Wood:

- Edgeband
- Knife

③ Cutout:

- No Cutout
- Center, Single-Sided/4 outlets, add \$33.13 list
- Center, Single-Sided/6 outlets, add \$33.13 list

④ Base and Wire Management Option:

Base - No Power:

- Casters, add \$15.60 list (29" Height Only)
- Glides

Base - Power Ready:

- Casters, add \$15.60 list (29" Height Only)
- Glides

- Laminate surface color or wood finish color.
- Edgeband trim color (laminates only).
- Base trim color.

Note: \$41.60 upcharge list for Metallic trim colors.

Jive Table — Post Round Base

Half Racetrack – Laminate or Wood

Height	Depth	Width	Number ① ② ③ ④	Laminate A		Laminate B		Wood Group A		Wood Group B				
				J	F	J	F	K	U	K	U			
Base — No Power — No Cutout														
29"(737mm)	42"(1067mm)	42"(1067mm)	TCHT-4242-	S	V	4	\$352.45	\$593.97	\$366.31	\$ 607.83	\$ 799.51	\$1135.95	\$ 920.02	\$1303.00
	48"(1219mm)	48"(1219mm)	TCHT-4848-	S	V	4	436.00	706.08	456.16	726.24	1064.80	1525.70	1233.28	1761.54
	54"(1372mm)	54"(1372mm)	TCHT-5454-	S	V	4	530.05	828.69	557.35	855.99	1363.51	1969.46	1585.94	2283.61
	60"(1524mm)	60"(1524mm)	TCHT-6060-	S	V	4	634.60	961.80	669.88	997.08	1695.64	2467.90	1978.00	2870.00
Base — Power Ready — No Cutout														
29"(737mm)	42"(1067mm)	42"(1067mm)	TCHT-4242-	S	V	4	\$372.45	\$613.97	\$386.31	\$ 627.83	\$ 819.51	\$1155.95	\$ 940.02	\$1323.00
	48"(1219mm)	48"(1219mm)	TCHT-4848-	S	V	4	456.00	726.08	476.16	746.24	1084.80	1545.70	1253.28	1781.54
	54"(1372mm)	54"(1372mm)	TCHT-5454-	S	V	4	550.05	848.69	577.35	875.99	1383.51	1989.46	1605.94	2303.61
	60"(1524mm)	60"(1524mm)	TCHT-6060-	S	V	4	654.60	981.80	689.88	1017.08	1715.64	2487.90	1998.00	2890.00

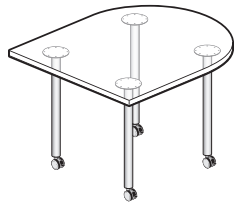

TCHT

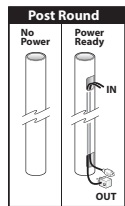

Features

- Includes 1 3/16"(30mm) thick top, leg bases, adjustable glides or casters, and hardware.
- Standard table height is 29"(737mm).
- Laminate top with knife edge or 3mm edgeband edges or wood veneer top with 3mm wood edgeband or knife edge.
- Bases are painted steel.
- Casters:
 - Two locking and two non-locking casters with 5/8"(16mm) adjustment.
 - Standard in black.
- Glides:
 - 5/8"(16mm) adjustment.
 - Standard in black.
- Casters and glides are not interchangeable.
- Depth and width shown in nominal dimensions.
- Ships unassembled.

Specification Tips

- Edge choice allows a flat seam between tables.
- **Specifying a cutout does not automatically include a Power Ready base.**
- Factory installed cutout is available for:
 - Specify the (F) option for a Center, Single-Sided/4 outlet Flip Top Unit
 - Specify the (J) option for a Center, Single-Sided/6 outlet Flip Top Unit
 - Specify the (M) option for a Center, Double-Sided/8 outlet Flip Top Unit
 - Specify the (Q) option for a Center, Double-Sided/12 outlet Flip Top Unit
- Power Ready Base:
 - Allows for cord management through one of the Post Extruded legs.
- **Powered leg location determined during installation.**
 - Casters and Glides:
 - Specify the (J) option for Casters on the Power Ready base (only available on 29"(737mm) high tables)
 - Specify the (K) option for Glides on the Power Ready base (available on 29"(737mm) high tables)
 - Flip Top Unit circuit breaker plug fits Power Ready Base opening.
- **Power cord length determines the distance to building power source.**
- Separately specified:
 - Ganging Mechanism - Recommended for use with power between tables.
 - Horizontal and Vertical Wire Management
 - Power and Data Components
 - Accessories
- Refer to Specification Guide:
 - Accessory placement and compatibility.
 - Seating capacities and leg locations.
 - Information on electrical components compatible with factory cut opening.
 - Power Ready base cable capacity.
- Application may require approval of local authority having jurisdiction (AHJ); ensure compliance before placing orders and installation.

To Order, Specify:

1) Product number, including:

① Surface Option:

- L** Laminate
- W** Wood

② Edge Option:

Laminate:

- J** Edgeband
- F** Knife

Wood:

- K** Edgeband
- U** Knife

③ Cutout:

- N** No Cutout
- F** Center, Single-Sided/4 outlets, add \$33.13 list
- J** Center, Single-Sided/6 outlets, add \$33.13 list
- M** Center, Double-Sided/8 outlets, add \$33.13 list
- Q** Center, Double-Sided/12 outlets, add \$33.13 list

④ Base and Wire Management Option:

Base - No Power:

- C** Casters, add \$15.60 list (29" Height Only)
- G** Glides

Base - Power Ready:

- J** Casters, add \$15.60 list (29" Height Only)
- K** Glides

- 2) Laminate surface color or wood finish color.
- 3) Edgeband trim color (laminate only).
- 4) Base trim color.

Note: \$41.60 upcharge list for Metallic trim colors.

Jive Table — Post Round Base

Pebble Half – Laminate or Wood

Height	Depth	Width	Number	Laminate A		Laminate B		Wood Group A		Wood Group B				
				J	F	J	F	K	U	K	U			
Base — No Power — No Cutout														
29"(737mm)	42"(1067mm)	42"(1067mm)	TCHP-4242-	S	V	4	\$352.45	\$593.97	\$366.31	\$ 607.83	\$ 799.51	\$1135.95	\$ 920.02	\$1303.00
	48"(1219mm)	48"(1219mm)	TCHP-4848-	S	V	4	436.00	706.08	456.16	726.24	1064.80	1525.70	1233.28	1761.54
	54"(1372mm)	54"(1372mm)	TCHP-5454-	S	V	4	530.05	828.69	557.35	855.99	1363.51	1969.46	1585.94	2283.61
	60"(1524mm)	60"(1524mm)	TCHP-6060-	S	V	4	634.60	961.80	669.88	997.08	1695.64	2467.90	1978.00	2870.00
Base — Power Ready — No Cutout														
29"(737mm)	42"(1067mm)	42"(1067mm)	TCHP-4242-	S	V	4	\$372.45	\$613.97	\$386.31	\$ 627.83	\$ 819.51	\$1155.95	\$ 940.02	\$1323.00
	48"(1219mm)	48"(1219mm)	TCHP-4848-	S	V	4	456.00	726.08	476.16	746.24	1084.80	1545.70	1253.28	1781.54
	54"(1372mm)	54"(1372mm)	TCHP-5454-	S	V	4	550.05	848.69	577.35	875.99	1383.51	1989.46	1605.94	2303.61
	60"(1524mm)	60"(1524mm)	TCHP-6060-	S	V	4	654.60	981.80	689.88	1017.08	1715.64	2487.90	1998.00	2890.00

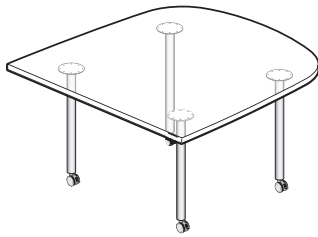

TCHP

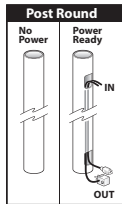

Features

- Includes 1 3/16"(30mm) thick top, leg bases, adjustable glides or casters, and hardware.
- Standard table height is 29"(737mm).
- Laminate top with knife edge or 3mm edgeband edges or wood veneer top with 3mm wood edgeband or knife edge.
- Bases are painted steel.
- Casters:
 - Two locking and two non-locking casters with 5/8"(16mm) adjustment.
 - Standard in black.
- Glides:
 - 5/8"(16mm) adjustment.
 - Standard in black.
- Casters and glides are not interchangeable.
- Depth and width shown in nominal dimensions.
- Ships unassembled.

Specification Tips

- Edge choice allows a flat seam between tables.
- **Specifying a cutout does not automatically include a Power Ready base.**
- Factory installed cutout is available for:
 - Specify the (F) option for a Center, Single-Sided/4 outlet Flip Top Unit
 - Specify the (J) option for a Center, Single-Sided/6 outlet Flip Top Unit
 - Specify the (M) option for a Center, Double-Sided/8 outlet Flip Top Unit
 - Specify the (Q) option for a Center, Double-Sided/12 outlet Flip Top Unit
- Power Ready Base:
 - Allows for cord management through one of the Post Extruded legs.
- **Powered leg location determined during installation.**
 - Casters and Glides:
 - Specify the (J) option for Casters on the Power Ready base (only available on 29"(737mm) high tables)
 - Specify the (K) option for Glides on the Power Ready base (available on 29"(737mm) high tables)
 - Flip Top Unit circuit breaker plug fits Power Ready Base opening.
- **Power cord length determines the distance to building power source.**
- Separately specified:
 - Ganging Mechanism - Recommended for use with power between tables.
 - Horizontal and Vertical Wire Management
 - Power and Data Components
 - Accessories
- Refer to Specification Guide:
 - Accessory placement and compatibility.
 - Seating capacities and leg locations.
 - Information on electrical components compatible with factory cut opening.
 - Power Ready base cable capacity.
- Application may require approval of local authority having jurisdiction (AHJ); ensure compliance before placing orders and installation.

To Order, Specify:

- 1) Product number, including:

1 Surface Option:

- L Laminate
- W Wood

2 Edge Option:

Laminate:

- J Edgeband
- F Knife

Wood:

- K Edgeband
- U Knife

3 Cutout:

- N No Cutout
- F Center, Single-Sided/4 outlets, add \$33.13 list
- J Center, Single-Sided/6 outlets, add \$33.13 list
- M Center, Double-Sided/8 outlets, add \$33.13 list
- Q Center, Double-Sided/12 outlets, add \$33.13 list

4 Base and Wire Management Option:

Base - No Power:

- C Casters, add \$15.60 list (29" Height Only)
- G Glides

Base - Power Ready:

- J Casters, add \$15.60 list (29" Height Only)
- K Glides

- 2) Laminate surface color or wood finish color.
- 3) Edgeband trim color (laminates only).
- 4) Base trim color.

Note: \$41.60 upcharge list for Metallic trim colors.

Jive Table — X-Base

Round – Laminate or Wood

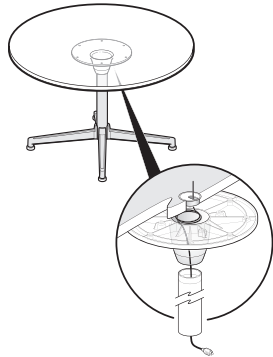

TCRN-SNXF (Base — Power Ready)



TCRN-SNX_ (Base — No Power)

Features

- Includes 1 3/16" (30mm) thick standard top, base, adjustable glides or casters and hardware.
- Standard table heights are 16" (406mm), 20" (508mm), 29" (737mm), 36" (914mm) and 42" (1067mm).
- Laminate top with knife edge or 3mm edgeband edges or wood veneer top with 3mm wood edgeband or knife edge.
- Casters:
 - Two locking and two non-locking casters with 5/8" (16mm) adjustment.
 - Standard in black.
- Glides:
 - 5/8" (16mm) adjustment.
 - Standard in black.
- Casters and glides are not interchangeable.
- Ships unassembled.

Specification Tips

- Base Sizes:
 - 24" (610mm) tops include 22" (559mm) X-Base
 - 30" (762mm) tops include 28" (711mm) X-Base
 - 36" (914mm) tops include 31" (787mm) X-Base
 - 42" (1067mm) tops include 37" (940mm) X-Base
 - 48" (1219mm) tops include 37" (940mm) X-Base
- **Specifying a cutout does not automatically include a Power Ready base.**
- Factory installed cutout is available for:
 - Specify the (R) option for a Centered, Flush Mount Power - Round
- Power Ready Base:
 - Allows for cord management through the X-Base.
 - Casters and Glides:
 - Specify the (J) option for Casters on the Power Ready base (available 29" (737mm), 36" (914mm), and 42" (1067mm) high tables)
 - Specify the (K) option for Glides on the Power Ready base (available 29" (737mm), 36" (914mm), and 42" (1067mm) high tables)
 - Flip Top Unit circuit breaker plug fits Power Ready Base opening.
- **Power cord length determines the distance to building power source.**
- Separately specified:
 - Horizontal and Vertical Wire Management
 - Power and Data Components
 - Accessories
- Refer to Specification Guide:
 - Accessory placement and compatibility.
 - Seating capacities and base location.
 - Information on electrical components compatible with factory cut opening.
 - Power Ready base cable capacity.
- Application may require approval of local authority having jurisdiction (AHJ); ensure compliance before placing orders and installation.

To Order, Specify:

1) Product number, including:

1 Surface Option:

- L** Laminate
- W** Wood

2 Edge Option:

Laminate:

- J** Edgeband
- F** Knife

Wood:

- K** Edgeband
- U** Knife

3 Cutout Option:

- N** No Cutout (No Power or Power Ready)
- R** 3" (76mm) Cutout (Power Ready base option only) add **\$33.13** list

4 Base and Wire Management Option:

Base — No Power:

- C** Casters, add **\$15.60** list
- G** Glides

Base — Power Ready:

- J** Casters, add **\$15.60** list
- K** Glides

5 Base Finish Option:

- A** Painted
- B** Polished, add **\$46.80** list

- 2) Laminate surface color or wood finish color.
- 3) Edgeband trim color (laminate only).
- 4) Base trim color.

Note: **\$41.60** upcharge list for Metallic trim colors.

Jive Table — X-Base

Round – Laminate or Wood

Height	Depth	Width	Number	① ② ③ ④ ⑤					Laminate A		Laminate B		Wood Group A		Wood Group B	
				J	F	J	F	K	U	K	U					
Base — No Power																
16"(406mm)	24"(610mm)	24"(610mm)	TCRN-2424-	■	■	■	■	■	\$ 476.62	\$ 632.46	\$ 476.62	\$ 632.46	\$ 515.98	\$ 602.00	\$ 528.46	\$ 619.73
	30"(762mm)	30"(762mm)	TCRN-3030-	■	■	■	■	■	528.67	713.07	532.45	716.85	681.01	829.94	723.52	887.92
	36"(914mm)	36"(914mm)	TCRN-3636-	■	■	■	■	■	591.22	804.18	599.62	812.58	879.46	1111.62	957.98	1219.33
	42"(1067mm)	42"(1067mm)	TCRN-4242-	■	■	■	■	■	664.27	905.79	678.13	919.65	1111.33	1447.77	1231.84	1614.82
	48"(1219mm)	48"(1219mm)	TCRN-4848-	■	■	■	■	■	747.82	1017.90	767.98	1038.06	1376.62	1837.52	1545.10	2073.36
20"(508mm)	24"(610mm)	24"(610mm)	TCRN-2424-	■	■	■	■	■	\$ 482.03	\$ 637.87	\$ 482.03	\$ 637.87	\$ 521.39	\$ 607.41	\$ 533.87	\$ 625.14
	30"(762mm)	30"(762mm)	TCRN-3030-	■	■	■	■	■	534.08	718.48	537.86	722.26	686.42	835.35	728.93	893.33
	36"(914mm)	36"(914mm)	TCRN-3636-	■	■	■	■	■	596.63	809.59	605.03	817.99	884.87	1117.03	963.39	1224.74
	42"(1067mm)	42"(1067mm)	TCRN-4242-	■	■	■	■	■	669.68	911.20	683.54	925.06	1116.74	1453.18	1237.25	1620.23
	48"(1219mm)	48"(1219mm)	TCRN-4848-	■	■	■	■	■	753.23	1023.31	773.39	1043.47	1382.03	1842.93	1550.51	2078.77
29"(737mm)	24"(610mm)	24"(610mm)	TCRN-2424-	■	■	■	■	■	\$ 498.16	\$ 654.00	\$ 498.16	\$ 654.00	\$ 537.52	\$ 623.54	\$ 550.00	\$ 641.27
	30"(762mm)	30"(762mm)	TCRN-3030-	■	■	■	■	■	550.21	734.61	553.99	738.39	702.55	851.48	745.06	909.46
	36"(914mm)	36"(914mm)	TCRN-3636-	■	■	■	■	■	612.76	825.72	621.16	834.12	901.00	1133.16	979.52	1240.87
	42"(1067mm)	42"(1067mm)	TCRN-4242-	■	■	■	■	■	685.81	927.33	699.67	941.19	1132.87	1469.31	1253.38	1636.36
	48"(1219mm)	48"(1219mm)	TCRN-4848-	■	■	■	■	■	769.36	1039.44	789.52	1059.60	1398.16	1859.06	1566.64	2094.90
36"(914mm)	24"(610mm)	24"(610mm)	TCRN-2424-	■	■	■	■	■	\$ 493.26	\$ 649.10	\$ 493.26	\$ 649.10	\$ 532.62	\$ 618.64	\$ 545.10	\$ 636.37
	30"(762mm)	30"(762mm)	TCRN-3030-	■	■	■	■	■	545.31	729.71	549.09	733.49	697.65	846.58	740.16	904.56
	36"(914mm)	36"(914mm)	TCRN-3636-	■	■	■	■	■	607.86	820.82	616.26	829.22	896.10	1128.26	974.62	1235.97
	42"(1067mm)	42"(1067mm)	TCRN-4242-	■	■	■	■	■	680.91	922.43	694.77	936.29	1127.97	1464.41	1248.48	1631.46
	48"(1219mm)	48"(1219mm)	TCRN-4848-	■	■	■	■	■	764.46	1034.54	784.62	1054.70	1393.26	1854.16	1561.74	2090.00
42"(1067mm)	24"(610mm)	24"(610mm)	TCRN-2424-	■	■	■	■	■	\$ 504.07	\$ 659.91	\$ 504.07	\$ 659.91	\$ 543.43	\$ 629.45	\$ 555.91	\$ 647.18
	30"(762mm)	30"(762mm)	TCRN-3030-	■	■	■	■	■	556.12	740.52	559.90	744.30	708.46	857.39	750.97	915.37
	36"(914mm)	36"(914mm)	TCRN-3636-	■	■	■	■	■	618.67	831.63	627.07	840.03	906.91	1139.07	985.43	1246.78
	42"(1067mm)	42"(1067mm)	TCRN-4242-	■	■	■	■	■	691.72	933.24	705.58	947.10	1138.78	1475.22	1259.29	1642.27
	48"(1219mm)	48"(1219mm)	TCRN-4848-	■	■	■	■	■	775.27	1045.35	795.43	1065.51	1404.07	1864.97	1572.55	2100.81
Base — Power Ready																
16"(406mm)	24"(610mm)	24"(610mm)	TCRN-2424-	■	■	■	■	■	\$ 705.92	\$ 861.76	\$ 705.92	\$ 861.76	\$ 745.28	\$ 831.30	\$ 757.76	\$ 849.03
	30"(762mm)	30"(762mm)	TCRN-3030-	■	■	■	■	■	757.97	942.37	761.75	946.15	910.31	1059.24	952.82	1117.22
	36"(914mm)	36"(914mm)	TCRN-3636-	■	■	■	■	■	820.52	1033.48	828.92	1041.88	1108.76	1340.92	1187.28	1448.63
	42"(1067mm)	42"(1067mm)	TCRN-4242-	■	■	■	■	■	893.57	1135.09	907.43	1148.95	1340.63	1677.07	1461.14	1844.12
	48"(1219mm)	48"(1219mm)	TCRN-4848-	■	■	■	■	■	977.12	1247.20	997.28	1267.36	1605.92	2066.82	1774.40	2302.66
20"(508mm)	24"(610mm)	24"(610mm)	TCRN-2424-	■	■	■	■	■	\$ 711.33	\$ 867.17	\$ 711.33	\$ 867.17	\$ 750.69	\$ 836.71	\$ 763.17	\$ 854.44
	30"(762mm)	30"(762mm)	TCRN-3030-	■	■	■	■	■	763.38	947.78	767.16	951.56	915.72	1064.65	958.23	1122.63
	36"(914mm)	36"(914mm)	TCRN-3636-	■	■	■	■	■	825.93	1038.89	834.33	1047.29	1114.17	1346.33	1192.69	1454.04
	42"(1067mm)	42"(1067mm)	TCRN-4242-	■	■	■	■	■	898.98	1140.50	912.84	1154.36	1346.04	1682.48	1466.55	1849.53
	48"(1219mm)	48"(1219mm)	TCRN-4848-	■	■	■	■	■	982.53	1252.61	1002.69	1272.77	1611.33	2072.23	1779.81	2308.07
29"(737mm)	24"(610mm)	24"(610mm)	TCRN-2424-	■	■	■	■	■	\$ 727.46	\$ 883.30	\$ 727.46	\$ 883.30	\$ 766.82	\$ 852.84	\$ 779.30	\$ 870.57
	30"(762mm)	30"(762mm)	TCRN-3030-	■	■	■	■	■	779.51	963.91	783.29	967.69	931.85	1080.78	974.36	1138.76
	36"(914mm)	36"(914mm)	TCRN-3636-	■	■	■	■	■	842.06	1055.02	850.46	1063.42	1130.30	1362.46	1208.82	1470.17
	42"(1067mm)	42"(1067mm)	TCRN-4242-	■	■	■	■	■	915.11	1156.63	928.97	1170.49	1362.17	1698.61	1482.68	1865.66
	48"(1219mm)	48"(1219mm)	TCRN-4848-	■	■	■	■	■	998.66	1268.74	1018.82	1288.90	1627.46	2088.36	1795.94	2324.20
36"(914mm)	24"(610mm)	24"(610mm)	TCRN-2424-	■	■	■	■	■	\$ 722.56	\$ 878.40	\$ 722.56	\$ 878.40	\$ 761.92	\$ 847.94	\$ 774.40	\$ 865.67
	30"(762mm)	30"(762mm)	TCRN-3030-	■	■	■	■	■	774.61	959.01	778.39	962.79	926.95	1075.88	969.46	1133.86
	36"(914mm)	36"(914mm)	TCRN-3636-	■	■	■	■	■	837.16	1050.12	845.56	1058.52	1125.40	1357.56	1203.92	1465.27
	42"(1067mm)	42"(1067mm)	TCRN-4242-	■	■	■	■	■	910.21	1151.73	924.07	1165.59	1357.27	1693.71	1477.78	1860.76
	48"(1219mm)	48"(1219mm)	TCRN-4848-	■	■	■	■	■	993.76	1263.84	1013.92	1284.00	1622.56	2083.46	1791.04	2319.30
42"(1067mm)	24"(610mm)	24"(610mm)	TCRN-2424-	■	■	■	■	■	\$ 733.37	\$ 889.21	\$ 733.37	\$ 889.21	\$ 772.73	\$ 858.75	\$ 785.21	\$ 876.48
	30"(762mm)	30"(762mm)	TCRN-3030-	■	■	■	■	■	785.42	969.82	789.20	973.60	937.76	1086.69	980.27	1144.67
	36"(914mm)	36"(914mm)	TCRN-3636-	■	■	■	■	■	847.97	1060.93	856.37	1069.33	1136.21	1368.37	1214.73	1476.08
	42"(1067mm)	42"(1067mm)	TCRN-4242-	■	■	■	■	■	921.02	1162.54	934.88	1176.40	1368.08	1704.52	1488.59	1871.57
	48"(1219mm)	48"(1219mm)	TCRN-4848-	■	■	■	■	■	1004.57	1274.65	1024.73	1294.81	1633.37	2094.27	1801.85	2330.11

Jive Table — X-Base

Square – Laminate or Wood

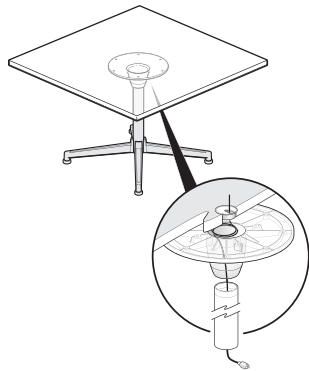

TCRQ-SNXF (Base - Power Ready)



TCRQ-SNX_ (Base - No Power)

Features

- Includes 1 3/16" (30mm) thick standard top, base, adjustable glides or casters and hardware.
- Standard table heights are 16" (406mm), 20" (508mm), 29" (737mm), 36" (914mm) and 42" (1067mm).
- Laminate top with knife edge or 3mm edgeband edges or wood veneer top with 3mm wood edgeband or knife edge.
- Casters:
 - Two locking and two non-locking casters with 5/8" (16mm) adjustment.
 - Standard in black.
- Glides:
 - 5/8" (16mm) adjustment.
 - Standard in black.
- Casters and glides are not interchangeable.
- Ships unassembled.

Specification Tips

- Edge choice allows a flat seam between tables.
- Base Sizes:
 - 24" (610mm) tops include 22" (559mm) X-Base
 - 30" (762mm) tops include 28" (711mm) X-Base
 - 36" (914mm) tops include 31" (787mm) X-Base
 - 42" (1067mm) tops include 37" (940mm) X-Base
 - 48" (1219mm) tops include 37" (940mm) X-Base
- **Specifying a cutout does not automatically include a Power Ready base.**
- Factory installed cutout is available for:
 - Specify the (R) option for a Centered, Flush Mount Power - Round
- Power Ready Base:
 - Allows for cord management through the X-Base.
 - Casters and Glides:
 - Specify the (J) option for Casters on the Power Ready base (available 29" (737mm), 36" (914mm), and 42" (1067mm) high tables)
 - Specify the (K) option for Glides on the Power Ready base (available 29" (737mm), 36" (914mm), and 42" (1067mm) high tables)
- **Power cord length determines the distance to building power source.**
- Separately specified:
 - Ganging Mechanism - Recommended for use with power between tables.
 - Horizontal and Vertical Wire Management
 - Power and Data Components
 - Accessories
- Refer to Specification Guide:
 - Accessory placement and compatibility.
 - Seating capacities and base location.
 - Information on electrical components compatible with factory cut opening.
 - Power Ready base cable capacity.
- Application may require approval of local authority having jurisdiction (AHJ); ensure compliance before placing orders and installation.

To Order, Specify:

1) Product number, including:

1 Surface Option:

- L** Laminate
- W** Wood

2 Edge Option:

Laminate:

- J** Edgeband
- F** Knife

Wood:

- K** Edgeband
- U** Knife

3 Cutout Option:

- N** No Cutout (No Power or Power Ready)
- R** 3" (76mm) Cutout (Power Ready base option only) add **\$33.13** list

4 Base and Wire Management Option:

Base - No Power:

- C** Casters, add **\$15.60** list
- G** Glides

Base - Power Ready:

- J** Casters, add **\$15.60** list
- K** Glides

5 Base Finish Option:

- A** Painted
- B** Polished, add **\$46.80** list

- 2) Laminate surface color or wood finish color.
- 3) Edgeband trim color (laminated only).
- 4) Base trim color.

Note: **\$41.60** upcharge list for Metallic trim colors.

Jive Table — X Base

Square – Laminate or Wood

Height	Depth	Width	Number	① ② ③ ④ ⑤					Laminate A		Laminate B		Wood Group A		Wood Group B	
				J	F	J	F	K	U	K	U					
Base — No Power																
16"(406mm)	24"(610mm)	24"(610mm)	TCRQ-2424-	■ ■ SNXG1	\$ 476.62	\$ 632.46	\$ 476.62	\$ 632.46	\$ 515.98	\$ 602.00	\$ 528.46	\$ 619.73				
	30"(762mm)	30"(762mm)	TCRQ-3030-	■ ■ SNXG1	528.67	713.07	532.45	716.85	681.01	829.94	723.52	887.92				
	36"(914mm)	36"(914mm)	TCRQ-3636-	■ ■ SNXG1	591.22	804.18	599.62	812.58	879.46	1111.62	957.98	1219.33				
	42"(1067mm)	42"(1067mm)	TCRQ-4242-	■ ■ SNXG1	664.27	905.79	678.13	919.65	1111.33	1447.77	1231.84	1614.82				
	48"(1219mm)	48"(1219mm)	TCRQ-4848-	■ ■ SNXG1	747.82	1017.90	767.98	1038.06	1376.62	1837.52	1545.10	2073.36				
20"(508mm)	24"(610mm)	24"(610mm)	TCRQ-2424-	■ ■ SNXG2	\$ 482.03	\$ 637.87	\$ 482.03	\$ 637.87	\$ 521.39	\$ 607.41	\$ 533.87	\$ 625.14				
	30"(762mm)	30"(762mm)	TCRQ-3030-	■ ■ SNXG2	534.08	718.48	537.86	722.26	686.42	835.35	728.93	893.33				
	36"(914mm)	36"(914mm)	TCRQ-3636-	■ ■ SNXG2	596.63	809.59	605.03	817.99	884.87	1117.03	963.39	1224.74				
	42"(1067mm)	42"(1067mm)	TCRQ-4242-	■ ■ SNXG2	669.68	911.20	683.54	925.06	1116.74	1453.18	1237.25	1620.23				
	48"(1219mm)	48"(1219mm)	TCRQ-4848-	■ ■ SNXG2	753.23	1023.31	773.39	1043.47	1382.03	1842.93	1550.51	2078.77				
29"(737mm)	24"(610mm)	24"(610mm)	TCRQ-2424-	■ ■ SNX 4	\$ 498.16	\$ 654.00	\$ 498.16	\$ 654.00	\$ 537.52	\$ 623.54	\$ 550.00	\$ 641.27				
	30"(762mm)	30"(762mm)	TCRQ-3030-	■ ■ SNX 4	550.21	734.61	553.99	738.39	702.55	851.48	745.06	909.46				
	36"(914mm)	36"(914mm)	TCRQ-3636-	■ ■ SNX 4	612.76	825.72	621.16	834.12	901.00	1133.16	979.52	1240.87				
	42"(1067mm)	42"(1067mm)	TCRQ-4242-	■ ■ SNX 4	685.81	927.33	699.67	941.19	1132.87	1469.31	1253.38	1636.36				
	48"(1219mm)	48"(1219mm)	TCRQ-4848-	■ ■ SNX 4	769.36	1039.44	789.52	1059.60	1398.16	1859.06	1566.64	2094.90				
36"(914mm)	24"(610mm)	24"(610mm)	TCRQ-2424-	■ ■ SNX 6	\$ 493.26	\$ 649.10	\$ 493.26	\$ 649.10	\$ 532.62	\$ 618.64	\$ 545.10	\$ 636.37				
	30"(762mm)	30"(762mm)	TCRQ-3030-	■ ■ SNX 6	545.31	729.71	549.09	733.49	697.65	846.58	740.16	904.56				
	36"(914mm)	36"(914mm)	TCRQ-3636-	■ ■ SNX 6	607.86	820.82	616.26	829.22	896.10	1128.26	974.62	1235.97				
	42"(1067mm)	42"(1067mm)	TCRQ-4242-	■ ■ SNX 6	680.91	922.43	694.77	936.29	1127.97	1464.41	1248.48	1631.46				
	48"(1219mm)	48"(1219mm)	TCRQ-4848-	■ ■ SNX 6	764.46	1034.54	784.62	1054.70	1393.26	1854.16	1561.74	2090.00				
42"(1067mm)	24"(610mm)	24"(610mm)	TCRQ-2424-	■ ■ SNX 7	\$ 504.07	\$ 659.91	\$ 504.07	\$ 659.91	\$ 543.43	\$ 629.45	\$ 555.91	\$ 647.18				
	30"(762mm)	30"(762mm)	TCRQ-3030-	■ ■ SNX 7	556.12	740.52	559.90	744.30	708.46	857.39	750.97	915.37				
	36"(914mm)	36"(914mm)	TCRQ-3636-	■ ■ SNX 7	618.67	831.63	627.07	840.03	906.91	1139.07	985.43	1246.78				
	42"(1067mm)	42"(1067mm)	TCRQ-4242-	■ ■ SNX 7	691.72	933.24	705.58	947.10	1138.78	1475.22	1259.29	1642.27				
	48"(1219mm)	48"(1219mm)	TCRQ-4848-	■ ■ SNX 7	775.27	1045.35	795.43	1065.51	1404.07	1864.97	1572.55	2100.81				
Base — Power Ready																
16"(406mm)	24"(610mm)	24"(610mm)	TCRQ-2424-	■ ■ S XK1	\$ 705.92	\$ 861.76	\$ 705.92	\$ 861.76	\$ 745.28	\$ 831.30	\$ 757.76	\$ 849.03				
	30"(762mm)	30"(762mm)	TCRQ-3030-	■ ■ S XK1	757.97	942.37	761.75	946.15	910.31	1059.24	952.82	1117.22				
	36"(914mm)	36"(914mm)	TCRQ-3636-	■ ■ S XK1	820.52	1033.48	828.92	1041.88	1108.76	1340.92	1187.28	1448.63				
	42"(1067mm)	42"(1067mm)	TCRQ-4242-	■ ■ S XK1	893.57	1135.09	907.43	1148.95	1340.63	1677.07	1461.14	1844.12				
	48"(1219mm)	48"(1219mm)	TCRQ-4848-	■ ■ S XK1	977.12	1247.20	997.28	1267.36	1605.92	2066.82	1774.40	2302.66				
20"(508mm)	24"(610mm)	24"(610mm)	TCRQ-2424-	■ ■ S XK2	\$ 711.33	\$ 867.17	\$ 711.33	\$ 867.17	\$ 750.69	\$ 836.71	\$ 763.17	\$ 854.44				
	30"(762mm)	30"(762mm)	TCRQ-3030-	■ ■ S XK2	763.38	947.78	767.16	951.56	915.72	1064.65	958.23	1122.63				
	36"(914mm)	36"(914mm)	TCRQ-3636-	■ ■ S XK2	825.93	1038.89	834.33	1047.29	1114.17	1346.33	1192.69	1454.04				
	42"(1067mm)	42"(1067mm)	TCRQ-4242-	■ ■ S XK2	898.98	1140.50	912.84	1154.36	1346.04	1682.48	1466.55	1849.53				
	48"(1219mm)	48"(1219mm)	TCRQ-4848-	■ ■ S XK2	982.53	1252.61	1002.69	1272.77	1611.33	2072.23	1779.81	2308.07				
29"(737mm)	24"(610mm)	24"(610mm)	TCRQ-2424-	■ ■ S X 4	\$ 727.46	\$ 883.30	\$ 727.46	\$ 883.30	\$ 766.82	\$ 852.84	\$ 779.30	\$ 870.57				
	30"(762mm)	30"(762mm)	TCRQ-3030-	■ ■ S X 4	779.51	963.91	783.29	967.69	931.85	1080.78	974.36	1138.76				
	36"(914mm)	36"(914mm)	TCRQ-3636-	■ ■ S X 4	842.06	1055.02	850.46	1063.42	1130.30	1362.46	1208.82	1470.17				
	42"(1067mm)	42"(1067mm)	TCRQ-4242-	■ ■ S X 4	915.11	1156.63	928.97	1170.49	1362.17	1698.61	1482.68	1865.66				
	48"(1219mm)	48"(1219mm)	TCRQ-4848-	■ ■ S X 4	998.66	1268.74	1018.82	1288.90	1627.46	2088.36	1795.94	2324.20				
36"(914mm)	24"(610mm)	24"(610mm)	TCRQ-2424-	■ ■ S X 6	\$ 722.56	\$ 878.40	\$ 722.56	\$ 878.40	\$ 761.92	\$ 847.94	\$ 774.40	\$ 865.67				
	30"(762mm)	30"(762mm)	TCRQ-3030-	■ ■ S X 6	774.61	959.01	778.39	962.79	926.95	1075.88	969.46	1133.86				
	36"(914mm)	36"(914mm)	TCRQ-3636-	■ ■ S X 6	837.16	1050.12	845.56	1058.52	1125.40	1357.56	1203.92	1465.27				
	42"(1067mm)	42"(1067mm)	TCRQ-4242-	■ ■ S X 6	910.21	1151.73	924.07	1165.59	1357.27	1693.71	1477.78	1860.76				
	48"(1219mm)	48"(1219mm)	TCRQ-4848-	■ ■ S X 6	993.76	1263.84	1013.92	1284.00	1622.56	2083.46	1791.04	2319.30				
42"(1067mm)	24"(610mm)	24"(610mm)	TCRQ-2424-	■ ■ S X 7	\$ 733.37	\$ 889.21	\$ 733.37	\$ 889.21	\$ 772.73	\$ 858.75	\$ 785.21	\$ 876.48				
	30"(762mm)	30"(762mm)	TCRQ-3030-	■ ■ S X 7	785.42	969.82	789.20	973.60	937.76	1086.69	980.27	1144.67				
	36"(914mm)	36"(914mm)	TCRQ-3636-	■ ■ S X 7	847.97	1060.93	856.37	1069.33	1136.21	1368.37	1214.73	1476.08				
	42"(1067mm)	42"(1067mm)	TCRQ-4242-	■ ■ S X 7	921.02	1162.54	934.88	1176.40	1368.08	1704.52	1488.59	1871.57				
	48"(1219mm)	48"(1219mm)	TCRQ-4848-	■ ■ S X 7	1004.57	1274.65	1024.73	1294.81	1633.37	2094.27	1801.85	2330.11				

Jive Table — X-Base

Pebble – Laminate or Wood

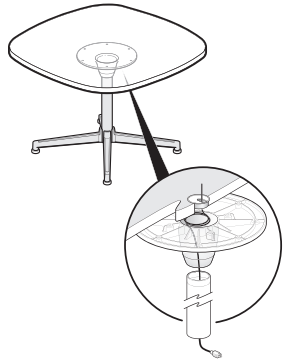

TCRP-SNXF (Base — Power Ready)



TCRP-SNX_ (Base — No Power)

Features

- Includes 1 3/16"(30mm) thick standard top, base, adjustable glides or casters and hardware.
- Standard table heights are 16"(406mm), 20"(508mm), 29"(737mm), 36"(914mm) and 42"(1067mm).
- Laminate top with knife edge or 3mm edgeband edges or wood veneer top with 3mm wood edgeband or knife edge.
- Casters:
 - Two locking and two non-locking casters with 5/8"(16mm) adjustment.
 - Standard in black.
- Glides:
 - 5/8"(16mm) adjustment.
 - Standard in black.
- Casters and glides are not interchangeable.
- Ships unassembled.

Specification Tips

- Base Sizes:
 - 24"(610mm) tops include 22"(559mm) X-Base
 - 30"(762mm) tops include 28"(711mm) X-Base
 - 36"(914mm) tops include 31"(787mm) X-Base
 - 42"(1067mm) tops include 37"(940mm) X-Base
 - 48"(1219mm) tops include 37"(940mm) X-Base
- **Specifying a cutout does not automatically include a Power Ready base.**
- Factory installed cutout is available for:
 - Specify the (R) option for a Centered, Flush Mount Power - Round
- Power Ready Base:
 - Allows for cord management through the X-Base.
 - Casters and Glides:
 - Specify the (J) option for Casters on the Power Ready base (available 29"(737mm), 36"(914mm), and 42"(1067mm) high tables)
 - Specify the (K) option for Glides on the Power Ready base (available 29"(737mm), 36"(914mm), and 42"(1067mm) high tables)
 - Flip Top Unit circuit breaker plug fits Power Ready Base opening.
- **Power cord length determines the distance to building power source.**
- Separately specified:
 - Horizontal and Vertical Wire Management
 - Power and Data Components
 - Accessories
- Refer to Specification Guide:
 - Accessory placement and compatibility.
 - Seating capacities and base location.
 - Information on electrical components compatible with factory cut opening.
 - Power Ready base cable capacity.
- Application may require approval of local authority having jurisdiction (AHJ); ensure compliance before placing orders and installation.

To Order, Specify:

1) Product number, including:

1 Surface Option:

- L** Laminate
- W** Wood

2 Edge Option:

Laminate:

- J** Edgeband
- F** Knife

Wood:

- K** Edgeband
- U** Knife

3 Cutout Option:

- N** No Cutout (No Power or Power Ready)
- R** 3"(76mm) Cutout (Power Ready base option only) add **\$33.13** list

4 Base and Wire Management Option:

Base — No Power:

- C** Casters, add **\$15.60** list
- G** Glides

Base — Power Ready:

- J** Casters, add **\$15.60** list
- K** Glides

5 Base Finish Option:

- A** Painted
- B** Polished, add **\$46.80** list

- 2) Laminate surface color or wood finish color.
- 3) Edgeband trim color (laminate only).
- 4) Base trim color.

Note: **\$41.60** upcharge list for Metallic trim colors.

Jive Table — X-Base

Pebble – Laminate or Wood

Height	Depth	Width	Number						Laminate A		Laminate B		Wood Group A		Wood Group B	
				1	2	3	4	5	J	F	J	F	K	U	K	U
Base — No Power																
16"(406mm)	24"(610mm)	24"(610mm)	TCRP-2424-						\$476.62	\$ 632.46	\$476.62	\$ 632.46	\$ 515.98	\$ 602.00	\$ 528.46	\$ 619.73
	30"(762mm)	30"(762mm)	TCRP-3030-						528.67	713.07	532.45	716.85	681.01	829.94	723.52	887.92
	36"(914mm)	36"(914mm)	TCRP-3636-						591.22	804.18	599.62	812.58	879.46	1111.62	957.98	1219.33
	42"(1067mm)	42"(1067mm)	TCRP-4242-						664.27	905.79	678.13	919.65	1111.33	1447.77	1231.84	1614.82
	48"(1219mm)	48"(1219mm)	TCRP-4848-						747.82	1017.90	767.98	1038.06	1376.62	1837.52	1545.10	2073.36
20"(508mm)	24"(610mm)	24"(610mm)	TCRP-2424-						\$482.03	\$ 637.87	\$482.03	\$ 637.87	\$ 521.39	\$ 607.41	\$ 533.87	\$ 625.14
	30"(762mm)	30"(762mm)	TCRP-3030-						534.08	718.48	537.86	722.26	686.42	835.35	728.93	893.33
	36"(914mm)	36"(914mm)	TCRP-3636-						596.63	809.59	605.03	817.99	884.87	1117.03	963.39	1224.74
	42"(1067mm)	42"(1067mm)	TCRP-4242-						669.68	911.20	683.54	925.06	1116.74	1453.18	1237.25	1620.23
	48"(1219mm)	48"(1219mm)	TCRP-4848-						753.23	1023.31	773.39	1043.47	1382.03	1842.93	1550.51	2078.77
29"(737mm)	24"(610mm)	24"(610mm)	TCRP-2424-				4		\$498.16	\$ 654.00	\$498.16	\$ 654.00	\$ 537.52	\$ 623.54	\$ 550.00	\$ 641.27
	30"(762mm)	30"(762mm)	TCRP-3030-				4		550.21	734.61	553.99	738.39	702.55	851.48	745.06	909.46
	36"(914mm)	36"(914mm)	TCRP-3636-				4		612.76	825.72	621.16	834.12	901.00	1133.16	979.52	1240.87
	42"(1067mm)	42"(1067mm)	TCRP-4242-				4		685.81	927.33	699.67	941.19	1132.87	1469.31	1253.38	1636.36
	48"(1219mm)	48"(1219mm)	TCRP-4848-				4		769.36	1039.44	789.52	1059.60	1398.16	1859.06	1566.64	2094.90
36"(914mm)	24"(610mm)	24"(610mm)	TCRP-2424-				6		\$493.26	\$ 649.10	\$493.26	\$ 649.10	\$ 532.62	\$ 618.64	\$ 545.10	\$ 636.37
	30"(762mm)	30"(762mm)	TCRP-3030-				6		545.31	729.71	549.09	733.49	697.65	846.58	740.16	904.56
	36"(914mm)	36"(914mm)	TCRP-3636-				6		607.86	820.82	616.26	829.22	896.10	1128.26	974.62	1235.97
	42"(1067mm)	42"(1067mm)	TCRP-4242-				6		680.91	922.43	694.77	936.29	1127.97	1464.41	1248.48	1631.46
	48"(1219mm)	48"(1219mm)	TCRP-4848-				6		764.46	1034.54	784.62	1054.70	1393.26	1854.16	1561.74	2090.00
42"(1067mm)	24"(610mm)	24"(610mm)	TCRP-2424-				7		\$504.07	\$ 659.91	\$504.07	\$ 659.91	\$ 543.43	\$ 629.45	\$ 555.91	\$ 647.18
	30"(762mm)	30"(762mm)	TCRP-3030-				7		556.12	740.52	559.90	744.30	708.46	857.39	750.97	915.37
	36"(914mm)	36"(914mm)	TCRP-3636-				7		618.67	831.63	627.07	840.03	906.91	1139.07	985.43	1246.78
	42"(1067mm)	42"(1067mm)	TCRP-4242-				7		691.72	933.24	705.58	947.10	1138.78	1475.22	1259.29	1642.27
	48"(1219mm)	48"(1219mm)	TCRP-4848-				7		775.27	1045.35	795.43	1065.51	1404.07	1864.97	1572.55	2100.81
Base — Power Ready																
16"(406mm)	24"(610mm)	24"(610mm)	TCRP-2424-			S	XK1		\$496.62	\$ 652.46	\$496.62	\$ 652.46	\$ 535.98	\$ 622.00	\$ 548.46	\$ 639.73
	30"(762mm)	30"(762mm)	TCRP-3030-			S	XK1		548.67	733.07	552.45	736.85	701.01	849.94	743.52	907.92
	36"(914mm)	36"(914mm)	TCRP-3636-			S	XK1		611.22	824.18	619.62	832.58	899.46	1131.62	977.98	1239.33
	42"(1067mm)	42"(1067mm)	TCRP-4242-			S	XK1		684.27	925.79	698.13	939.65	1131.33	1467.77	1251.84	1634.82
	48"(1219mm)	48"(1219mm)	TCRP-4848-			S	XK1		767.82	1037.90	787.98	1058.06	1396.62	1857.52	1565.10	2093.36
20"(508mm)	24"(610mm)	24"(610mm)	TCRP-2424-			S	XK2		\$502.03	\$ 657.87	\$502.03	\$ 657.87	\$ 541.39	\$ 627.41	\$ 553.87	\$ 645.14
	30"(762mm)	30"(762mm)	TCRP-3030-			S	XK2		554.08	738.48	557.86	742.26	706.42	855.35	748.93	913.33
	36"(914mm)	36"(914mm)	TCRP-3636-			S	XK2		616.63	829.59	625.03	837.99	904.87	1137.03	983.39	1244.74
	42"(1067mm)	42"(1067mm)	TCRP-4242-			S	XK2		689.68	931.20	703.54	945.06	1136.74	1473.18	1257.25	1640.23
	48"(1219mm)	48"(1219mm)	TCRP-4848-			S	XK2		773.23	1043.31	793.39	1063.47	1402.03	1862.93	1570.51	2098.77
29"(737mm)	24"(610mm)	24"(610mm)	TCRP-2424-			S	X	4	\$518.16	\$ 674.00	\$518.16	\$ 674.00	\$ 557.52	\$ 643.54	\$ 570.00	\$ 661.27
	30"(762mm)	30"(762mm)	TCRP-3030-			S	X	4	570.21	754.61	573.99	758.39	722.55	871.48	765.06	929.46
	36"(914mm)	36"(914mm)	TCRP-3636-			S	X	4	632.76	845.72	641.16	854.12	921.00	1153.16	999.52	1260.87
	42"(1067mm)	42"(1067mm)	TCRP-4242-			S	X	4	705.81	947.33	719.67	961.19	1152.87	1489.31	1273.38	1656.36
	48"(1219mm)	48"(1219mm)	TCRP-4848-			S	X	4	789.36	1059.44	809.52	1079.60	1418.16	1879.06	1586.64	2114.90
36"(914mm)	24"(610mm)	24"(610mm)	TCRP-2424-			S	X	6	\$513.26	\$ 669.10	\$513.26	\$ 669.10	\$ 552.62	\$ 638.64	\$ 565.10	\$ 656.37
	30"(762mm)	30"(762mm)	TCRP-3030-			S	X	6	565.31	749.71	569.09	753.49	717.65	866.58	760.16	924.56
	36"(914mm)	36"(914mm)	TCRP-3636-			S	X	6	627.86	840.82	636.26	849.22	916.10	1148.26	994.62	1255.97
	42"(1067mm)	42"(1067mm)	TCRP-4242-			S	X	6	700.91	942.43	714.77	956.29	1147.97	1484.41	1268.48	1651.46
	48"(1219mm)	48"(1219mm)	TCRP-4848-			S	X	6	784.46	1054.54	804.62	1074.70	1413.26	1874.16	1581.74	2110.00
42"(1067mm)	24"(610mm)	24"(610mm)	TCRP-2424-			S	X	7	\$524.07	\$ 679.91	\$524.07	\$ 679.91	\$ 563.43	\$ 649.45	\$ 575.91	\$ 667.18
	30"(762mm)	30"(762mm)	TCRP-3030-			S	X	7	576.12	760.52	579.90	764.30	728.46	877.39	770.97	935.37
	36"(914mm)	36"(914mm)	TCRP-3636-			S	X	7	638.67	851.63	647.07	860.03	926.91	1159.07	1005.43	1266.78
	42"(1067mm)	42"(1067mm)	TCRP-4242-			S	X	7	711.72	953.24	725.58	967.10	1158.78	1495.22	1279.29	1662.27
	48"(1219mm)	48"(1219mm)	TCRP-4848-			S	X	7	795.27	1065.35	815.43	1085.51	1424.07	1884.97	1592.55	2120.81

Jive Table — X-Base

Rectangle – Laminate or Wood

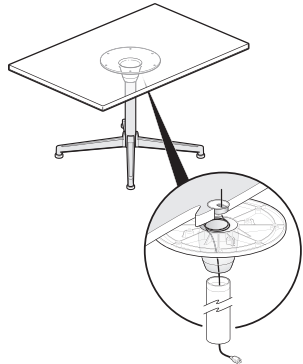

TCRA-SNXF (Base — Power Ready)



TCRA-SNX_ (Base — No Power)

Features

- Includes 1 3/16" (30mm) thick standard top, base, adjustable glides or casters and hardware.
- Standard table heights are 16" (406mm), 20" (508mm), 29" (737mm), 36" (914mm) and 42" (1067mm).
- Laminate top with knife edge or 3mm edgeband edges or wood veneer top with 3mm wood edgeband or knife edge.
- Casters:
 - Two locking and two non-locking casters with 5/8" (16mm) adjustment.
 - Standard in black.
- Glides:
 - 5/8" (16mm) adjustment.
 - Standard in black.
- Casters and glides are not interchangeable.
- Ships unassembled.

Specification Tips

- Base Sizes:
 - 24" (610mm) tops include 22" (559mm) X-Base
 - 30" (762mm) tops include 28" (711mm) X-Base
 - 36" (914mm) tops include 31" (787mm) X-Base
 - 42" (1067mm) tops include 37" (940mm) X-Base
 - 48" (1219mm) tops include 37" (940mm) X-Base
- **Specifying a cutout does not automatically include a Power Ready base.**
- Factory installed cutout is available for:
 - Specify the (R) option for a Centered, Flush Mount Power - Round
- Power Ready Base:
 - Allows for cord management through the X-Base.
 - Casters and Glides:
 - Specify the (J) option for Casters on the Power Ready base (available 29" (737mm), 36" (914mm), and 42" (1067mm) high tables)
 - Specify the (K) option for Glides on the Power Ready base (available 29" (737mm), 36" (914mm), and 42" (1067mm) high tables)
 - Flip Top Unit circuit breaker plug fits Power Ready Base opening.
- **Power cord length determines the distance to building power source.**
- Separately specified:
 - Horizontal and Vertical Wire Management
 - Power and Data Components
 - Accessories
- Refer to Specification Guide:
 - Accessory placement and compatibility.
 - Seating capacities and base location.
 - Information on electrical components compatible with factory cut opening.
 - Power Ready base cable capacity.
- Application may require approval of local authority having jurisdiction (AHJ); ensure compliance before placing orders and installation.

To Order, Specify:

1) Product number, including:

1 Surface Option:

- L** Laminate
- W** Wood

2 Edge Option:

Laminate:

- J** Edgeband
- F** Knife

Wood:

- K** Edgeband
- U** Knife

3 Cutout Option:

- N** No Cutout (No Power or Power Ready)
- R** 3" (76mm) Cutout (Power Ready base option only) add **\$33.13** list

4 Base and Wire Management Option:

Base — No Power:

- C** Casters, add **\$15.60** list
- G** Glides

Base — Power Ready:

- J** Casters, add **\$15.60** list
- K** Glides

5 Base Finish Option:

- A** Painted
- B** Polished, add **\$46.80** list

- 2) Laminate surface color or wood finish color.
- 3) Edgeband trim color (laminate only).
- 4) Base trim color.

Note: **\$41.60** upcharge list for Metallic trim colors.

Jive Table — X Base

Rectangle – Laminate or Wood

Height	Depth	Width	Number						Laminate A		Laminate B		Wood Group A		Wood Group B	
				①	②	③	④	⑤	J	F	J	F	K	U	K	U
Base — No Power																
16"(406mm)	24"(610mm)	30"(762mm)	TCRA-2430-						\$488.31	\$635.30	\$558.15	\$705.14	\$ 911.52	\$1089.50	\$1001.35	\$1200.59
		36"(914mm)	TCRA-2436-						512.14	675.98	583.66	747.50	987.00	1186.79	1090.63	1315.07
	30"(762mm)	36"(914mm)	TCRA-3036-						545.70	721.76	619.74	795.80	1093.53	1309.13	1216.43	1459.16
		42"(1067mm)	TCRA-3042-						575.04	769.49	651.18	845.63	1186.50	1425.91	1326.37	1596.61
20"(508mm)	24"(610mm)	30"(762mm)	TCRA-2430-						\$493.72	\$640.71	\$563.56	\$710.55	\$ 916.93	\$1094.91	\$1006.76	\$1206.00
		36"(914mm)	TCRA-2436-						517.55	681.39	589.07	752.91	992.41	1192.20	1096.04	1320.48
	30"(762mm)	36"(914mm)	TCRA-3036-						551.11	727.17	625.15	801.21	1098.94	1314.54	1221.84	1464.57
		42"(1067mm)	TCRA-3042-						580.45	774.90	656.59	851.04	1191.91	1431.32	1331.78	1602.02
29"(737mm)	24"(610mm)	30"(762mm)	TCRA-2430-				4		\$509.85	\$656.84	\$579.69	\$726.68	\$ 933.06	\$1111.04	\$1022.89	\$1222.13
		36"(914mm)	TCRA-2436-				4		533.68	697.52	605.20	769.04	1008.54	1208.33	1112.17	1336.61
	30"(762mm)	36"(914mm)	TCRA-3036-				4		567.24	743.30	641.28	817.34	1115.07	1330.67	1237.97	1480.70
		42"(1067mm)	TCRA-3042-				4		596.58	791.03	672.72	867.17	1208.04	1447.45	1347.91	1618.15
36"(914mm)	24"(610mm)	30"(762mm)	TCRA-2430-				6		\$504.95	\$651.94	\$574.79	\$721.78	\$ 928.16	\$1106.14	\$1017.99	\$1217.23
		36"(914mm)	TCRA-2436-				6		528.78	692.62	600.30	764.14	1003.64	1203.43	1107.27	1331.71
	30"(762mm)	36"(914mm)	TCRA-3036-				6		562.34	738.40	636.38	812.44	1110.17	1325.77	1233.07	1475.80
		42"(1067mm)	TCRA-3042-				6		591.68	786.13	667.82	862.27	1203.14	1442.55	1343.01	1613.25
42"(1067mm)	24"(610mm)	30"(762mm)	TCRA-2430-				7		\$515.76	\$662.75	\$585.60	\$732.59	\$ 938.97	\$1116.95	\$1028.80	\$1228.04
		36"(914mm)	TCRA-2436-				7		539.59	703.43	611.11	774.95	1014.45	1214.24	1118.08	1342.52
	30"(762mm)	36"(914mm)	TCRA-3036-				7		573.15	749.21	647.19	823.25	1120.98	1336.58	1243.88	1486.61
		42"(1067mm)	TCRA-3042-				7		602.49	796.94	678.63	873.08	1213.95	1453.36	1353.82	1624.06
Base — Power Ready																
16"(406mm)	24"(610mm)	30"(762mm)	TCRA-2430-			S	XK1		\$508.31	\$655.30	\$578.15	\$725.14	\$ 931.52	\$1109.50	\$1021.35	\$1220.59
		36"(914mm)	TCRA-2436-			S	XK1		532.14	695.98	603.66	767.50	1007.00	1206.79	1110.63	1335.07
	30"(762mm)	36"(914mm)	TCRA-3036-			S	XK1		565.70	741.76	639.74	815.80	1113.53	1329.13	1236.43	1479.16
		42"(1067mm)	TCRA-3042-			S	XK1		595.04	789.49	671.18	865.63	1206.50	1445.91	1346.37	1616.61
20"(508mm)	24"(610mm)	30"(762mm)	TCRA-2430-			S	XK2		\$513.72	\$660.71	\$583.56	\$730.55	\$ 936.93	\$1114.91	\$1026.76	\$1226.00
		36"(914mm)	TCRA-2436-			S	XK2		537.55	701.39	609.07	772.91	1012.41	1212.20	1116.04	1340.48
	30"(762mm)	36"(914mm)	TCRA-3036-			S	XK2		571.11	747.17	645.15	821.21	1118.94	1334.54	1241.84	1484.57
		42"(1067mm)	TCRA-3042-			S	XK2		600.45	794.90	676.59	871.04	1211.91	1451.32	1351.78	1622.02
29"(737mm)	24"(610mm)	30"(762mm)	TCRA-2430-			S	X	4	\$529.85	\$676.84	\$599.69	\$746.68	\$ 953.06	\$1131.04	\$1042.89	\$1242.13
		36"(914mm)	TCRA-2436-			S	X	4	553.68	717.52	625.20	789.04	1028.54	1228.33	1132.17	1356.61
	30"(762mm)	36"(914mm)	TCRA-3036-			S	X	4	587.24	763.30	661.28	837.34	1135.07	1350.67	1257.97	1500.70
		42"(1067mm)	TCRA-3042-			S	X	4	616.58	811.03	692.72	887.17	1228.04	1467.45	1367.91	1638.15
36"(914mm)	24"(610mm)	30"(762mm)	TCRA-2430-			S	X	6	\$524.95	\$671.94	\$594.79	\$741.78	\$ 948.16	\$1126.14	\$1037.99	\$1237.23
		36"(914mm)	TCRA-2436-			S	X	6	548.78	712.62	620.30	784.14	1023.64	1223.43	1127.27	1351.71
	30"(762mm)	36"(914mm)	TCRA-3036-			S	X	6	582.34	758.40	656.38	832.44	1130.17	1345.77	1253.07	1495.80
		42"(1067mm)	TCRA-3042-			S	X	6	611.68	806.13	687.82	882.27	1223.14	1462.55	1363.01	1633.25
42"(1067mm)	24"(610mm)	30"(762mm)	TCRA-2430-			S	X	7	\$535.76	\$682.75	\$605.60	\$752.59	\$ 958.97	\$1136.95	\$1048.80	\$1248.04
		36"(914mm)	TCRA-2436-			S	X	7	559.59	723.43	631.11	794.95	1034.45	1234.24	1138.08	1362.52
	30"(762mm)	36"(914mm)	TCRA-3036-			S	X	7	593.15	769.21	667.19	843.25	1140.98	1356.58	1263.88	1506.61
		42"(1067mm)	TCRA-3042-			S	X	7	622.49	816.94	698.63	893.08	1233.95	1473.36	1373.82	1644.06

Jive Table — Bridge Base

Round – Laminate or Wood

No. of Columns	Height	Depth	Width	Number	①	②	③	④	Laminate A		Laminate B		Wood Group A		Wood Group B	
									J	F	J	F	K	U	K	U
Base — No Power — No Cutout																
4	20"(508mm)	48"(1219mm)	48"(1219mm)	TCRN-4848-	■	S	GG2	■	\$1178.34	\$1448.42	\$1178.34	\$1448.42	\$1807.14	\$2268.04	\$1975.62	\$2503.88
4		54"(1372mm)	54"(1372mm)	TCRN-5454-	■	S	GG2	■	1272.39	1571.03	1272.39	1571.03	2105.85	2711.80	2328.28	3025.95
4		60"(1524mm)	60"(1524mm)	TCRN-6060-	■	S	GG2	■	1376.94	1704.14	1376.94	1704.14	2437.98	3210.24	2720.34	3612.34
4	29"(737mm)	48"(1219mm)	48"(1219mm)	TCRN-4848-	■	S	GG4	■	\$1205.38	\$1475.46	\$1225.54	\$1495.62	\$1834.18	\$2295.08	\$2002.66	\$2530.92
4		54"(1372mm)	54"(1372mm)	TCRN-5454-	■	S	GG4	■	1299.43	1598.07	1299.43	1598.07	2132.89	2738.84	2355.32	3052.99
4		60"(1524mm)	60"(1524mm)	TCRN-6060-	■	S	GG4	■	1403.98	1731.18	1403.98	1731.18	2465.02	3237.28	2747.38	3639.38
Base — Power Ready — No Cutout																
4	20"(508mm)	48"(1219mm)	48"(1219mm)	TCRN-4848-	■	S	GK2	■	\$1198.34	\$1468.42	\$1198.34	\$1468.42	\$1827.14	\$2288.04	\$1995.62	\$2523.88
4		54"(1372mm)	54"(1372mm)	TCRN-5454-	■	S	GK2	■	1292.39	1591.03	1292.39	1591.03	2125.85	2731.80	2348.28	3045.95
4		60"(1524mm)	60"(1524mm)	TCRN-6060-	■	S	GK2	■	1396.94	1724.14	1396.94	1724.14	2457.98	3230.24	2740.34	3632.34
4	29"(737mm)	48"(1219mm)	48"(1219mm)	TCRN-4848-	■	S	GK4	■	\$1225.38	\$1495.46	\$1245.54	\$1515.62	\$1854.18	\$2315.08	\$2022.66	\$2550.92
4		54"(1372mm)	54"(1372mm)	TCRN-5454-	■	S	GK4	■	1319.43	1618.07	1319.43	1618.07	2152.89	2758.84	2375.32	3072.99
4		60"(1524mm)	60"(1524mm)	TCRN-6060-	■	S	GK4	■	1423.98	1751.18	1423.98	1751.18	2485.02	3257.28	2767.38	3659.38



TCRN-SNG

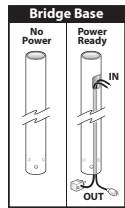

Features

- Includes 1 3/16"(30mm) thick standard top, base, adjustable glides and hardware.
- Standard table heights are 20"(508mm) and 29"(737mm).
- Laminate top with knife edge or 3mm edgeband edges or wood veneer top with 3mm wood edgeband or knife edge.
- Glides:
 - 5/8"(16mm) adjustment.
 - Standard is black.
- Ships unassembled.

Specification Tips

- **Specifying a cutout does not automatically include a Power Ready base.**
- Factory installed cutout is available for:
 - Specify the (F) option for a Center, Single-Sided/4 outlet Flip Top Unit
 - Specify the (J) option for a Center, Single-Sided/6 outlet Flip Top Unit
 - Specify the (M) option for a Center, Double-Sided/8 outlet Flip Top Unit
- Power Ready Base:
 - Allows for cord management through one of the Bridge Base columns. **Powered leg location determined during installation.**
 - Available with Glides only.
 - Flip Top Unit circuit breaker plug fits Power Ready Base opening.
- **Power cord length determines the distance to building power source.**
- Separately specified:
 - Horizontal and Vertical Wire Management
 - Power and Data Components
 - Accessories
- Refer to Specification Guide:
 - Accessory placement and compatibility.
 - Seating capacities and leg locations.
 - Information on electrical components compatible with factory cut opening.
 - Power Ready base cable capacity.
- Application may require approval of local authority having jurisdiction (AHJ); ensure compliance before placing orders and installation.

To Order, Specify:

- 1) Product number, including:

① Surface Option:

- L Laminate
- W Wood

② Edge Option:

Laminate:

- J Edgeband
- F Knife

Wood:

- K Edgeband
- U Knife

③ Cutout:

- N No Cutout
- F Center, Single-Sided/4 outlets, add \$33.13 list
- J Center, Single-Sided/6 outlets, add \$33.13 list
- M Center, Double-Sided/8 outlets, add \$33.13 list

④ Base Finish Option:

- A Painted
- B Polished, add \$46.80 list

- 2) Laminate surface color or wood finish color.
- 3) Edgeband trim color (laminated only).
- 4) Base trim color.

Note: \$41.60 upcharge list for Metallic trim colors.

Jive Table — Bridge Base

Square – Laminate or Wood

No. of Columns	Height	Depth	Width	Number	①	②	③	④	Laminate A		Laminate B		Wood Group A		Wood Group B	
									J	F	J	F	K	U	K	U
Base — No Power — No Cutout																
4	20"(508mm)	48"(1219mm)	48"(1219mm)	TCRQ-4848-	■	S	GG2	■	\$1178.34	\$1448.42	\$1198.50	\$1468.58	\$1807.14	\$2268.04	\$1975.62	\$2503.88
4		54"(1372mm)	54"(1372mm)	TCRQ-5454-	■	S	GG2	■	1272.39	1571.03	1299.69	1598.33	2105.85	2711.80	2328.28	3025.95
4		60"(1524mm)	60"(1524mm)	TCRQ-6060-	■	S	GG2	■	1376.94	1704.14	1412.22	1739.42	2437.98	3210.24	2720.34	3612.34
4	29"(737mm)	48"(1219mm)	48"(1219mm)	TCRQ-4848-	■	S	GG4	■	\$1205.38	\$1475.46	\$1225.54	\$1495.62	\$1834.18	\$2295.08	\$2002.66	\$2530.92
4		54"(1372mm)	54"(1372mm)	TCRQ-5454-	■	S	GG4	■	1299.43	1598.07	1326.73	1625.37	2132.89	2738.84	2355.32	3052.99
4		60"(1524mm)	60"(1524mm)	TCRQ-6060-	■	S	GG4	■	1403.98	1731.18	1439.26	1766.46	2465.02	3237.28	2747.38	3639.38
Base — Power Ready — No Cutout																
4	20"(508mm)	48"(1219mm)	48"(1219mm)	TCRQ-4848-	■	S	GK2	■	\$1198.34	\$1468.42	\$1218.50	\$1488.58	\$1827.14	\$2288.04	\$1995.62	\$2523.88
4		54"(1372mm)	54"(1372mm)	TCRQ-5454-	■	S	GK2	■	1292.39	1591.03	1319.69	1618.33	2125.85	2731.80	2348.28	3045.95
4		60"(1524mm)	60"(1524mm)	TCRQ-6060-	■	S	GK2	■	1396.94	1724.14	1432.22	1759.42	2457.98	3230.24	2740.34	3632.34
4	29"(737mm)	48"(1219mm)	48"(1219mm)	TCRQ-4848-	■	S	GK4	■	\$1225.38	\$1495.46	\$1245.54	\$1515.62	\$1854.18	\$2315.08	\$2022.66	\$2550.92
4		54"(1372mm)	54"(1372mm)	TCRQ-5454-	■	S	GK4	■	1319.43	1618.07	1346.73	1645.37	2152.89	2758.84	2375.32	3072.99
4		60"(1524mm)	60"(1524mm)	TCRQ-6060-	■	S	GK4	■	1423.98	1751.18	1459.26	1786.46	2485.02	3257.28	2767.38	3659.38

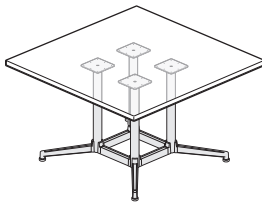

TCRQ-SNG

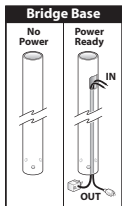

Features

- Includes 1 3/16"(30mm) thick standard top, base, adjustable glides and hardware.
- Standard table heights are 20"(508mm) and 29"(737mm).
- Laminate top with knife edge or 3mm edgeband edges or wood veneer top with 3mm wood edgeband or knife edge.
- Glides:
 - 5/8"(16mm) adjustment.
 - Standard in black.
- Ships unassembled.

Specification Tips

- Edge choice allows a flat seam between tables.
- Specifying a cutout does not automatically include a Power Ready base.**
- Factory installed cutout is available for:
 - Specify the (F) option for a Center, Single-Sided/4 outlet Flip Top Unit
 - Specify the (J) option for a Center, Single-Sided/6 outlet Flip Top Unit
 - Specify the (M) option for a Center, Double-Sided/8 outlet Flip Top Unit
- Power Ready Base:
 - Allows for cord management through one of the Bridge Base columns. **Powered leg location determined during installation.**
 - Available with Glides only.
 - Flip Top Unit circuit breaker plug fits Power Ready Base opening.
- Power cord length determines the distance to building power source.**
- Separately specified:
 - Ganging Mechanism - Recommended for use with power between tables.
 - Horizontal and Vertical Wire Management
 - Power and Data Components
 - Accessories
- Refer to Specification Guide:
 - Accessory placement and compatibility.
 - Seating capacities and leg locations.
 - Information on electrical components compatible with factory cut opening.
 - Power Ready base cable capacity.
- Application may require approval of local authority having jurisdiction (AHJ); ensure compliance before placing orders and installation.

To Order, Specify:

- Product number, including:

① Surface Option:

- L Laminate
- W Wood

② Edge Option:

Laminate:

- J Edgeband
- F Knife

Wood:

- K Edgeband
- U Knife

③ Cutout:

- N No Cutout
- F Center, Single-Sided/4 outlets, add \$33.13 list
- J Center, Single-Sided/6 outlets, add \$33.13 list
- M Center, Double-Sided/8 outlets, add \$33.13 list

④ Base Finish Option:

- A Painted
- B Polished, add \$46.80 list

- Laminate surface color or wood finish color.
- Edgeband trim color (laminate only).
- Base trim color.

Note: \$41.60 upcharge list for Metallic trim colors.

Jive Table — Bridge Base

Pebble – Laminate or Wood

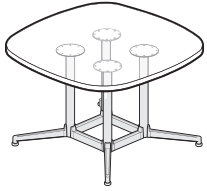

TCRP-5454-SNG (Symmetrical)



TCRP-3048-SNG (Asymmetrical)

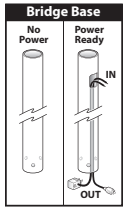

Features

- Includes 1 3/16" (30mm) thick standard top, base, adjustable glides or casters and hardware.
- Standard table heights are 16" (406mm), 20" (508mm), 29" (737mm), 36" (914mm) and 42" (1067mm).
- Laminate top with knife edge or 3mm edgeband edges or wood veneer top with 3mm wood edgeband or knife edge.
- Casters:
 - Two locking and two non-locking casters with 5/8" (16mm) adjustment.
 - Standard in black.
- Glides:
 - 5/8" (16mm) adjustment.
 - Standard in black.
- Casters and glides are not interchangeable.
- Ships unassembled.

Specification Tips

- Asymmetrical tables:
 - 144" (3658mm) and 180" (4572mm) width top has two pieces;
 - 216" (5486mm) top has three pieces.
- **Specifying a cutout does not automatically include a Power Ready base.**
- Factory installed cutout is available for tables 72" (1829mm) wide or less:
 - Specify the (F) option for a Center, Single-Sided/4 outlet Flip Top Unit
 - Specify the (J) option for a Center, Single-Sided/6 outlet Flip Top Unit
 - Specify the (M) option for a Center, Double-Sided/8 outlet Flip Top Unit
 - Specify the (Q) option for a Center, Double-Sided/12 outlet Flip Top Unit
- Factory installed cutout is available for:
 - Tables greater than 72" (1829mm) wide **except 84" (2134mm), 96" (2438mm) and 100" (2540mm) wide:**
 - Specify the (V) option for Left/Right, Single-Sided/4 outlet Flip Top Unit
 - Specify the (K) option for Left/Right, Single-Sided/6 outlet Flip Top Unit
 - Exception:
 - 54" (1372mm) depth x 96" (2438mm) wide will accept V and K option cutouts.
- Power Ready Base:
 - Allows for cord management through one of the Bridge Base Base columns.
 - Asymmetrical tables with 30" (762mm), 36" (914mm), 42" (1067mm) and 48" (1219mm) depths will have 2 or 3 columns. Powered leg location with:
 - Two columns is determined during installation.
 - Three columns is always centered.
 - Asymmetrical tables with 54" (1372mm) depths and Symmetrical tables will have 4 or more columns. Powered leg location with 6 and 8 columns determined at installation of interior legs.
 - Casters and Glides:
 - Specify the (J) option for Casters on the Power Ready base (only available Asymmetrical tables 29" (737mm) or 42" (1067mm) high with two columns).
 - Specify the (K) option for Glides on the Power Ready base (available on 16" (406mm), 20" (508mm), 29" (737mm), 36" (914mm) and 42" (1067mm) high tables).
 - Flip Top Unit circuit breaker plug fits Power Ready Base opening.
- **Power cord length determines the distance to building power source.**
- Separately specified:
 - Horizontal and Vertical Wire Management
 - Power and Data Components
 - Accessories
- Refer to Specification Guide:
 - Accessory placement and compatibility.
 - Seating capacities and leg locations.
 - Information on electrical components compatible with factory cut opening.
 - Power Ready base cable capacity.
- Application may require approval of local authority having jurisdiction (AHJ); ensure compliance before placing orders and installation.

To Order, Specify:

1) Product number, including:

1 Surface Option:

- L** Laminate
- W** Wood

2 Edge Option:

Laminate:

- J** Edgeband
- F** Knife

Wood:

- K** Edgeband
- U** Knife

3 Cutout:

- N** No Cutout
- F** Center, Single-Sided/4 outlets, add **\$33.13** list
- J** Center, Single-Sided/6 outlets, add **\$33.13** list
- M** Center, Double-Sided/8 outlets, add **\$33.13** list
- Q** Center, Double-Sided/12 outlets, add **\$33.13** list
- V** Left/Right, Single-Sided/4 outlets, add **\$33.13** list
- K** Left/Right, Single-Sided/6 outlets, add **\$33.13** list

4 Base and Wire Management Option:

Base - No Power:

- C** Casters, add **\$15.60** list (29" and 42" Heights Only)
- G** Glides

Base - Power Ready:

- J** Casters, add **\$15.60** list (29" and 42" Heights Only)
- K** Glides

5 Base Finish Option:

- A** Painted
- B** Polished, add **\$46.80** list

2) Laminate surface color or wood finish color.

3) Edgeband trim color (laminate only).

4) Base trim color.

Note: **\$41.60** upcharge list for Metallic trim colors.

Jive Table — Bridge Base

Pebble – Laminate or Wood

No. of Columns	Height	Depth	Width	Number	① ② ③ ④ ⑤	Laminate A		Laminate B		Wood Group A		Wood Group B	
						J	F	J	F	K	U	K	U
Symmetrical — Base — No Power — No Cutout													
4	20"(508mm)	48"(1219mm)	48"(1219mm)	TCRP-4848-	■ ■ S ■ GG2 ■	\$1178.34	\$1448.42	\$1198.50	\$1468.58	\$1807.14	\$2268.04	\$1975.62	\$2503.88
4		54"(1372mm)	54"(1372mm)	TCRP-5454-	■ ■ S ■ GG2 ■	1272.39	1571.03	1299.69	1598.33	2105.85	2711.80	2328.28	3025.95
4		60"(1524mm)	60"(1524mm)	TCRP-6060-	■ ■ S ■ GG2 ■	1376.94	1704.14	1412.22	1739.42	2437.98	3210.24	2720.34	3612.34
4	29"(737mm)	48"(1219mm)	48"(1219mm)	TCRP-4848-	■ ■ S ■ G ■ 4 ■	\$1205.38	\$1475.46	\$1225.54	\$1468.58	\$1834.18	\$2295.08	\$2002.66	\$2530.92
4		54"(1372mm)	54"(1372mm)	TCRP-5454-	■ ■ S ■ G ■ 4 ■	1299.43	1598.07	1326.73	1598.33	2132.89	2738.84	2355.32	3052.99
4		60"(1524mm)	60"(1524mm)	TCRP-6060-	■ ■ S ■ G ■ 4 ■	1403.98	1731.18	1439.26	1766.46	2465.02	3237.28	2747.38	3639.38
Symmetrical — Base — Power Ready — No Cutout													
4	20"(508mm)	48"(1219mm)	48"(1219mm)	TCRP-4848-	■ ■ S ■ GK2 ■	\$1198.34	\$1468.42	\$1218.50	\$1488.58	\$1827.14	\$2288.04	\$1995.62	\$2523.88
4		54"(1372mm)	54"(1372mm)	TCRP-5454-	■ ■ S ■ GK2 ■	1292.39	1591.03	1319.69	1618.33	2125.85	2731.80	2348.28	3045.95
4		60"(1524mm)	60"(1524mm)	TCRP-6060-	■ ■ S ■ GK2 ■	1396.94	1724.14	1432.22	1759.42	2457.98	3230.24	2740.34	3632.34
4	29"(737mm)	48"(1219mm)	48"(1219mm)	TCRP-4848-	■ ■ S ■ G ■ 4 ■	\$1225.38	\$1495.46	\$1245.54	\$1488.58	\$1854.18	\$2315.08	\$2022.66	\$2550.92
4		54"(1372mm)	54"(1372mm)	TCRP-5454-	■ ■ S ■ G ■ 4 ■	1319.43	1618.07	1346.73	1618.33	2152.89	2758.84	2375.32	3072.99
4		60"(1524mm)	60"(1524mm)	TCRP-6060-	■ ■ S ■ G ■ 4 ■	1423.98	1751.18	1459.26	1786.46	2485.02	3257.28	2767.38	3659.38

Jive Table — Bridge Base

Pebble – Laminate or Wood

No. of Columns	Height	Depth	Width	Number						Laminate A		Laminate B		Wood Group A		Wood Group B					
					①	②	③	④	⑤	J	F	J	K	K	U	K	U				
Asymmetrical — Base — No Power — No Cutout																					
2	16"(406mm)	30"(762mm)	48"(1219mm)	TCRP-3048-						S	GG1			\$1033.52	\$1247.40	\$1111.76	\$1325.64	\$ 1708.98	\$ 1973.52	\$ 1865.92	\$ 2165.21
2			60"(1524mm)	TCRP-3060-						S	GG1			1093.07	1348.87	1175.51	1431.31	1897.57	2216.37	2088.99	2450.99
2			72"(1829mm)	TCRP-3072-						S	GG1			1153.31	1455.15	1239.95	1541.79	2088.27	2466.65	2314.62	2745.48
2	16"(406mm)	36"(914mm)	60"(1524mm)	TCRP-3660-						S	GG1			\$1147.97	\$1418.05	\$1234.61	\$1504.69	\$ 2071.99	\$ 2409.27	\$ 2294.87	\$ 2678.23
2			72"(1829mm)	TCRP-3672-						S	GG1			1218.88	1536.03	1310.56	1627.71	2296.64	2694.83	2560.54	3014.30
2	20"(508mm)	30"(762mm)	48"(1219mm)	TCRP-3048-						S	GG2			\$1086.04	\$1299.92	\$1164.28	\$1378.16	\$ 1761.50	\$ 2026.04	\$ 1918.44	\$ 2217.73
2			60"(1524mm)	TCRP-3060-						S	GG2			1145.59	1401.39	1228.03	1483.83	1950.09	2268.89	2141.51	2503.51
2			72"(1829mm)	TCRP-3072-						S	GG2			1205.83	1507.67	1292.47	1594.31	2140.79	2519.17	2367.14	2798.00
2		36"(914mm)	60"(1524mm)	TCRP-3660-						S	GG2			\$1200.49	\$1470.57	\$1287.13	\$1557.21	\$ 2124.51	\$ 2461.79	\$ 2347.39	\$ 2730.75
2			72"(1829mm)	TCRP-3672-						S	GG2			1271.40	1588.55	1363.08	1680.23	2349.16	2747.35	2613.06	3066.82
2	29"(737mm)	30"(762mm)	48"(1219mm)	TCRP-3048-						S	G	4		\$1086.04	\$1299.92	\$1164.28	\$1378.16	\$ 1761.50	\$ 2026.04	\$ 1918.44	\$ 2217.73
2			60"(1524mm)	TCRP-3060-						S	G	4		1145.59	1401.39	1228.03	1483.83	1950.09	2268.89	2141.51	2503.51
2			72"(1829mm)	TCRP-3072-						S	G	4		1205.83	1507.67	1292.47	1594.31	2140.79	2519.17	2367.14	2798.00
2		36"(914mm)	60"(1524mm)	TCRP-3660-						S	G	4		\$1200.49	\$1470.57	\$1287.13	\$1557.21	\$ 2124.51	\$ 2461.79	\$ 2347.39	\$ 2730.75
2			72"(1829mm)	TCRP-3672-						S	G	4		1271.40	1588.55	1363.08	1680.23	2349.16	2747.35	2613.06	3066.82
3		42"(1067mm)	84"(2134mm)	TCRP-4284-						S	G	4		\$2558.17	\$2942.83	\$2660.77	\$3045.43	\$ 3957.15	\$ 4442.71	\$ 4306.16	\$ 4860.92
3			96"(2438mm)	TCRP-4296-						S	G	4		2641.13	3082.12	2749.61	3190.60	4219.96	4778.40	4616.99	5255.98
3		48"(1219mm)	96"(2438mm)	TCRP-4896-						S	G	4		\$2728.05	\$3186.40	\$2843.25	\$3301.60	\$ 4496.22	\$ 5077.14	\$ 4942.98	\$ 5607.95
3			108"(2743mm)	TCRP-48A8-						S	G	4		2822.38	3342.19	2944.30	3464.11	4795.08	5455.54	5296.40	6053.31
3			120"(3048mm)	TCRP-48C0-						S	G	4		2917.40	3502.78	3046.04	3631.42	5096.06	5841.37	5652.38	6507.37
6		54"(1372mm)	96"(2438mm)	TCRP-5496-						S	G	4		\$4819.20	\$5294.91	\$4941.12	\$5416.83	\$ 6776.71	\$ 7380.10	\$ 7273.21	\$ 7964.16
6			108"(2743mm)	TCRP-54A8-						S	G	4		4924.20	5462.40	5053.68	5591.88	7109.52	7793.78	7666.67	8451.09
6			120"(3048mm)	TCRP-54C0-						S	G	4		3130.71	3735.51	3267.75	3872.55	5545.25	6315.70	6163.50	7047.54
6			144"(3658mm)	TCRP-54E4-						S	G	4		2559.51	3351.87	2711.67	3504.03	5730.22	7155.05	6472.00	8039.77
8			180"(4572mm)	TCRP-54J0-						S	G	4		4923.81	5965.33	5098.65	6140.17	8799.21	10518.57	9729.67	11642.23
8			216"(5486mm)	TCRP-54M6-						S	G	4		5339.73	6818.52	5537.25	7016.04	10230.24	11933.34	11353.43	13307.43
2	36"(914mm)	30"(762mm)	48"(1219mm)	TCRP-3048-						S	GG6			\$1112.30	\$1326.18	\$1190.54	\$1404.42	\$ 1787.76	\$ 2052.30	\$ 1944.70	\$ 2243.99
2			60"(1524mm)	TCRP-3060-						S	GG6			1171.85	1427.65	1254.29	1510.09	1976.35	2295.15	2167.77	2529.77
2			72"(1829mm)	TCRP-3072-						S	GG6			1232.09	1533.93	1318.73	1620.57	2167.05	2545.43	2393.40	2824.26
2	36"(914mm)	36"(914mm)	60"(1524mm)	TCRP-3660-						S	GG6			\$1226.75	\$1496.83	\$1313.39	\$1583.47	\$ 2150.77	\$ 2488.05	\$ 2373.65	\$ 2757.01
2			72"(1829mm)	TCRP-3672-						S	GG6			1297.66	1614.81	1389.34	1706.49	2375.42	2773.61	2639.32	3093.08
2	42"(1067mm)	30"(762mm)	48"(1219mm)	TCRP-3048-						S	G	7		\$1138.56	\$1352.44	\$1216.80	\$1430.68	\$ 1814.02	\$ 2078.56	\$ 1970.96	\$ 2270.25
2			60"(1524mm)	TCRP-3060-						S	G	7		1198.11	1453.91	1280.55	1536.35	2002.61	2321.41	2194.03	2556.03
2			72"(1829mm)	TCRP-3072-						S	G	7		1258.35	1560.19	1344.99	1646.83	2193.31	2571.69	2419.66	2850.52
2	42"(1067mm)	36"(914mm)	60"(1524mm)	TCRP-3660-						S	G	7		\$1253.01	\$1523.09	\$1339.65	\$1609.73	\$ 2177.03	\$ 2514.31	\$ 2399.91	\$ 2783.27
2			72"(1829mm)	TCRP-3672-						S	G	7		1323.92	1641.07	1415.60	1732.75	2401.68	2799.87	2665.58	3119.34

Jive Table — Bridge Base

Pebble – Laminate or Wood

No. of Columns	Height	Depth	Width	Number	① ② ③ ④ ⑤	Laminate A		Laminate B		Wood Group A		Wood Group B	
						J	F	J	K	K	U	K	U
Asymmetrical — Base — Power Ready — No Cutout													
2	16"(406mm)	30"(762mm)	48"(1219mm)	TCRP-3048-	SNGK1	\$1053.52	\$1267.40	\$1131.76	\$1345.64	\$ 1728.98	\$ 1993.52	\$ 1885.92	\$ 2185.21
2			60"(1524mm)	TCRP-3060-	S GK1	1113.07	1368.87	1195.51	1451.31	1917.57	2236.37	2108.99	2470.99
2			72"(1829mm)	TCRP-3072-	S GK1	1173.31	1475.15	1259.95	1561.79	2108.27	2486.65	2334.62	2765.48
2	16"(406mm)	36"(914mm)	60"(1524mm)	TCRP-3660-	S GK1	\$1167.97	\$1438.05	\$1254.61	\$1524.69	\$ 2091.99	\$ 2429.27	\$ 2314.87	\$ 2698.23
2			72"(1829mm)	TCRP-3672-	S GK1	1238.88	1556.03	1330.56	1647.71	2316.64	2714.83	2580.54	3034.30
2	20"(508mm)	30"(762mm)	48"(1219mm)	TCRP-3048-	SNGK2	\$1106.04	\$1319.92	\$1184.28	\$1398.16	\$ 1781.50	\$ 2046.04	\$ 1938.44	\$ 2237.73
2			60"(1524mm)	TCRP-3060-	S GK2	1165.59	1421.39	1248.03	1503.83	1970.09	2288.89	2161.51	2523.51
2			72"(1829mm)	TCRP-3072-	S GK2	1225.83	1527.67	1312.47	1614.31	2160.79	2539.17	2387.14	2818.00
2		36"(914mm)	60"(1524mm)	TCRP-3660-	S GK2	\$1220.49	\$1490.57	\$1307.13	\$1577.21	\$ 2144.51	\$ 2481.79	\$ 2367.39	\$ 2750.75
2			72"(1829mm)	TCRP-3672-	S GK2	1291.40	1608.55	1383.08	1700.23	2369.16	2767.35	2633.06	3086.82
2	29"(737mm)	30"(762mm)	48"(1219mm)	TCRP-3048-	SNG 4	\$1106.04	\$1319.92	\$1184.28	\$1398.16	\$ 1781.50	\$ 2046.04	\$ 1938.44	\$ 2237.73
2			60"(1524mm)	TCRP-3060-	S G 4	1165.59	1421.39	1248.03	1503.83	1970.09	2288.89	2161.51	2523.51
2			72"(1829mm)	TCRP-3072-	S G 4	1225.83	1527.67	1312.47	1614.31	2160.79	2539.17	2387.14	2818.00
2		36"(914mm)	60"(1524mm)	TCRP-3660-	S G 4	\$1220.49	\$1490.57	\$1307.13	\$1577.21	\$ 2144.51	\$ 2481.79	\$ 2367.39	\$ 2750.75
2			72"(1829mm)	TCRP-3672-	S G 4	1291.40	1608.55	1383.08	1700.23	2369.16	2767.35	2633.06	3086.82
3		42"(1067mm)	84"(2134mm)	TCRP-4284-	SNG 4	\$2578.17	\$2962.83	\$2680.77	\$3065.43	\$ 3977.15	\$ 4462.71	\$ 4326.16	\$ 4880.92
3			96"(2438mm)	TCRP-4296-	SNG 4	2661.13	3102.12	2769.61	3210.60	4239.96	4798.40	4636.99	5275.98
3		48"(1219mm)	96"(2438mm)	TCRP-4896-	SNG 4	\$2748.05	\$3206.40	\$2863.25	\$3321.60	\$ 4516.22	\$ 5097.14	\$ 4962.98	\$ 5627.95
3			108"(2743mm)	TCRP-48A8-	SNG 4	2842.38	3362.19	2964.30	3484.11	4815.08	5475.54	5316.40	6073.31
3			120"(3048mm)	TCRP-48C0-	S G 4	2937.40	3522.78	3066.04	3651.42	5116.06	5861.37	5672.38	6527.37
6		54"(1372mm)	96"(2438mm)	TCRP-5496-	SNG 4	\$4839.20	\$5314.91	\$4961.12	\$5436.83	\$ 6796.71	\$ 7400.10	\$ 7293.21	\$ 7984.16
6			108"(2743mm)	TCRP-54A8-	SNG 4	4944.20	5482.40	5073.68	5611.88	7129.52	7813.78	7686.67	8471.09
6			120"(3048mm)	TCRP-54C0-	S G 4	3150.71	3755.51	3287.75	3892.55	5565.25	6335.70	6183.50	7067.54
6			144"(3658mm)	TCRP-54E4-	S G 4	2579.51	3371.87	2731.67	3524.03	5750.22	7175.05	6492.00	8059.77
8			180"(4572mm)	TCRP-54J0-	S G 4	4943.81	5985.33	5118.65	6160.17	8819.21	10538.57	9749.67	11662.23
8			216"(5486mm)	TCRP-54M6-	S G 4	5359.73	6838.52	5557.25	7036.04	10250.24	11953.34	11373.43	13327.43
2	36"(914mm)	30"(762mm)	48"(1219mm)	TCRP-3048-	SNGK6	\$1132.30	\$1346.18	\$1210.54	\$1424.42	\$ 1807.76	\$ 2072.30	\$ 1964.70	\$ 2263.99
2			60"(1524mm)	TCRP-3060-	S GK6	1191.85	1447.65	1274.29	1530.09	1996.35	2315.15	2187.77	2549.77
2			72"(1829mm)	TCRP-3072-	S GK6	1252.09	1553.93	1338.73	1640.57	2187.05	2565.43	2413.40	2844.26
2	36"(914mm)	36"(914mm)	60"(1524mm)	TCRP-3660-	S GK6	\$1246.75	\$1516.83	\$1333.39	\$1603.47	\$ 2170.77	\$ 2508.05	\$ 2393.65	\$ 2777.01
2			72"(1829mm)	TCRP-3672-	S GK6	1317.66	1634.81	1409.34	1726.49	2395.42	2793.61	2659.32	3113.08
2	42"(1067mm)	30"(762mm)	48"(1219mm)	TCRP-3048-	SNG 7	\$1158.56	\$1372.44	\$1236.80	\$1450.68	\$ 1834.02	\$ 2098.56	\$ 1990.96	\$ 2290.25
2			60"(1524mm)	TCRP-3060-	S G 7	1218.11	1473.91	1300.55	1556.35	2022.61	2341.41	2214.03	2576.03
2			72"(1829mm)	TCRP-3072-	S G 7	1278.35	1580.19	1364.99	1666.83	2213.31	2591.69	2439.66	2870.52
2	42"(1067mm)	36"(914mm)	60"(1524mm)	TCRP-3660-	S G 7	\$1273.01	\$1543.09	\$1359.65	\$1629.73	\$ 2197.03	\$ 2534.31	\$ 2419.91	\$ 2803.27
2			72"(1829mm)	TCRP-3672-	S G 7	1343.92	1661.07	1435.60	1752.75	2421.68	2819.87	2685.58	3139.34

This page intentionally blank

Jive Table — Bridge Base

Rectangle – Laminate or Wood

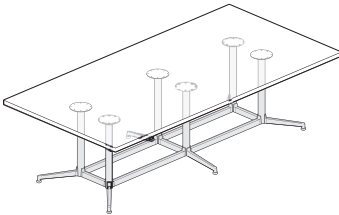
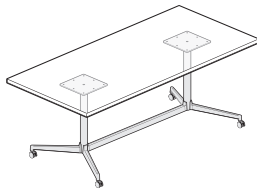

TCRA-SNG

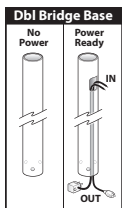
**Features**

- Includes 1 3/16" (30mm) thick standard top, base, adjustable glides or casters and hardware.
- Standard table heights are 16" (406mm), 20" (508mm), 29" (737mm), 36" (914mm) and 42" (1067mm).
- Laminate top with knife edge or 3mm edgeband edges or wood veneer top with 3mm wood edgeband or knife edge.
- Casters:
 - Two locking and two non-locking casters with 5/8" (16mm) adjustment.
 - Standard in black.
- Glides:
 - 5/8" (16mm) adjustment.
 - Standard in black.
- Casters and glides are not interchangeable.
- Ships unassembled.

Specification Tips

- Edge choice allows a flat seam between tables.
- Tables with more than one piece:
 - 144" (3658mm) and 180" (4572mm) width top has two pieces;
 - 216" (5486mm) top has three pieces.
- **Specifying a cutout does not automatically include a Power Ready base.**
- Factory installed cutout is available for tables 72" (1829mm) wide or less:
 - Specify the (F) option for a Center, Single-Sided/4 outlet Flip Top Unit
 - Specify the (J) option for a Center, Single-Sided/6 outlet Flip Top Unit
 - Specify the (M) option for a Center, Double-Sided/8 outlet Flip Top Unit
 - Specify the (Q) option for a Center, Double-Sided/12 outlet Flip Top Unit
- Factory installed cutout is available for:
 - Tables greater than **72" (1829mm) wide except 84" (2134mm), 96" (2438mm) and 108" (2743mm) wide:**
 - Specify the (V) option for Left/Right, Single-Sided/4 outlet Flip Top Unit
 - Specify the (K) option for Left/Right, Single-Sided/6 outlet Flip Top Unit
 - Exception:
 - 54" (1372mm) depth x 96" (2438mm) wide will accept V and K option cutouts.
- Power Ready Base:
 - Allows for cord management through one of the Bridge Base Base columns.
 - Tables with 30" (762mm), 36" (914mm), 42" (1067mm) and 48" (1219mm) depths will have 2 or 3 columns. Powered leg location with:
 - Two columns is determined during installation.
 - Three columns is always centered.
 - Tables with 54" (1372mm) depths will have 4 or more columns. Powered leg location with 6 and 8 columns determined at installation of interior legs.
 - Casters and Glides:
 - Specify the (J) option for Casters on the Power Ready base (only available with two column tables 29" (737mm) or 42" (1067mm) high)
 - Specify the (K) option for Glides on the Power Ready base (available on 16" (406mm), 20" (508mm), 29" (737mm), 36" (914mm) and 42" (1067mm) high tables).
 - Flip Top Unit circuit breaker plug fits Power Ready Base opening.
- **Power cord length determines the distance to building power source.**
- Separately specified:
 - Ganging Mechanism
 - Recommended for use with power between tables.
 - Horizontal and Vertical Wire Management
 - Power and Data Components
 - Accessories
- Refer to Specification Guide:
 - Accessory placement and compatibility.
 - Seating capacities and leg locations.
 - Information on electrical components compatible with factory cut opening.
 - Power Ready base cable capacity.
- Application may require approval of local authority having jurisdiction (AHJ); ensure compliance before placing orders and installation.

To Order, Specify:

- 1) Product number, including:

1 Surface Option:

- L** Laminate
- W** Wood

2 Edge Option:

Laminate:

- J** Edgeband
- F** Knife

Wood:

- K** Edgeband
- U** Knife

3 Cutout:

- N** No Cutout
- F** Center, Single-Sided/4 outlets, add **\$33.13** list
- J** Center, Single-Sided/6 outlets, add **\$33.13** list
- M** Center, Double-Sided/8 outlets, add **\$33.13** list
- Q** Center, Double-Sided/12 outlets, add **\$33.13** list
- V** Left/Right, Single-Sided/4 outlets, add **\$33.13** list
- K** Left/Right, Single-Sided/6 outlets, add **\$33.13** list

4 Base and Wire Management Option:

Base - No Power:

- C** Casters, add **\$15.60** list (29" and 42" Heights Only)
- G** Glides

Base - Power Ready:

- J** Casters, add **\$15.60** list (29" and 42" Heights Only)
- K** Glides

5 Base Finish Option:

- A** Painted
- B** Polished, add **\$46.80** list

- 2) Laminate surface color or wood finish color.
- 3) Edgeband trim color (laminates only).
- 4) Base trim color.

Note: **\$41.60** upcharge list for Metallic trim colors.

Jive Table — Bridge Base

Rectangle – Laminate or Wood

No. of Columns	Height	Depth	Width	Number						Laminate A		Laminate B		Wood Group A		Wood Group B			
					1	2	3	4	5	J	F	J	F	K	U	K	U		
Base — No Power — No Cutout																			
2	16"(406mm)	30"(762mm)	48"(1219mm)	TCRA-3048-						SNGG1		\$1033.52	\$1247.40	\$1111.76	\$1325.64	\$ 1708.98	\$ 1973.52	\$ 1865.92	\$ 2165.21
2			60"(1524mm)	TCRA-3060-					S	GG1		1093.07	1348.87	1175.51	1431.31	1897.57	2216.37	2088.99	2450.99
2			72"(1829mm)	TCRA-3072-					S	GG1		1153.31	1455.15	1239.95	1541.79	2088.27	2466.65	2314.62	2745.48
2	16"(406mm)	36"(914mm)	60"(1524mm)	TCRA-3660-					S	GG1		\$1147.97	\$1418.05	\$1234.61	\$1504.69	\$ 2071.99	\$ 2409.27	\$ 2294.87	\$ 2678.23
2			72"(1829mm)	TCRA-3672-					S	GG1		1218.88	1536.03	1310.56	1627.71	2296.64	2694.83	2560.54	3014.30
2	20"(508mm)	30"(762mm)	48"(1219mm)	TCRA-3048-					SNGG2		\$1086.04	\$1299.92	\$1164.28	\$1378.16	\$ 1761.50	\$ 2026.04	\$ 1918.44	\$ 2217.73	
2			60"(1524mm)	TCRA-3060-					S	GG2		1145.59	1401.39	1228.03	1483.83	1950.09	2268.89	2141.51	2503.51
2			72"(1829mm)	TCRA-3072-					S	GG2		1205.83	1507.67	1292.47	1594.31	2140.79	2519.17	2367.14	2798.00
2	20"(508mm)	36"(914mm)	60"(1524mm)	TCRA-3660-					S	GG2		\$1200.49	\$1470.57	\$1287.13	\$1557.21	\$ 2124.51	\$ 2461.79	\$ 2347.39	\$ 2730.75
2			72"(1829mm)	TCRA-3672-					S	GG2		1271.40	1588.55	1363.08	1680.23	2349.16	2747.35	2613.06	3066.82
2	29"(737mm)	30"(762mm)	48"(1219mm)	TCRA-3048-					SNG	4	\$1086.04	\$1299.92	\$1164.28	\$1378.16	\$ 1761.50	\$ 2026.04	\$ 1918.44	\$ 2217.73	
2			60"(1524mm)	TCRA-3060-					S	G 4	1145.59	1401.39	1228.03	1483.83	1950.09	2268.89	2141.51	2503.51	
2			72"(1829mm)	TCRA-3072-					S	G 4	1205.83	1507.67	1292.47	1594.31	2140.79	2519.17	2367.14	2798.00	
2	29"(737mm)	36"(914mm)	60"(1524mm)	TCRA-3660-					S	G 4	\$1200.49	\$1470.57	\$1287.13	\$1557.21	\$ 2124.51	\$ 2461.79	\$ 2347.39	\$ 2730.75	
2			72"(1829mm)	TCRA-3672-					S	G 4	1271.40	1588.55	1363.08	1680.23	2349.16	2747.35	2613.06	3066.82	
3	29"(737mm)	42"(1067mm)	84"(2134mm)	TCRA-4284-					SNGG4		\$2558.17	\$2942.83	\$2660.77	\$3045.43	\$ 3957.15	\$ 4442.71	\$ 4306.16	\$ 4860.92	
3			96"(2438mm)	TCRA-4296-					SNGG4		2641.13	3082.12	2749.61	3190.60	4219.96	4778.40	4616.99	5255.98	
3	29"(737mm)	48"(1219mm)	96"(2438mm)	TCRA-4896-					SNGG4		\$2728.05	\$3186.40	\$2843.25	\$3301.60	\$ 4496.22	\$ 5077.14	\$ 4942.98	\$ 5607.95	
3			108"(2743mm)	TCRA-48A8-					SNGG4		2822.38	3342.19	2944.30	3464.11	4795.08	5455.54	5296.40	6053.31	
3			120"(3048mm)	TCRA-48C0-					S	GG4	2917.40	3502.78	3046.04	3631.42	5096.06	5841.37	5652.38	6507.37	
6	29"(737mm)	54"(1372mm)	96"(2438mm)	TCRA-5496-					SNGG4		\$2920.01	\$3395.72	\$3041.93	\$3517.64	\$ 4877.52	\$ 5480.91	\$ 5374.02	\$ 6064.97	
6			108"(2743mm)	TCRA-54A8-					SNGG4		3025.01	3563.21	3154.49	3692.69	5210.33	5894.59	5767.48	6551.90	
6			120"(3048mm)	TCRA-54C0-					S	GG4	3130.71	3735.51	3267.75	3872.55	5545.25	6315.70	6163.50	7047.54	
6			144"(3658mm)	TCRA-54E4-					S	GG4	4458.70	5251.06	4610.86	5403.22	7629.41	9054.24	8371.19	9938.96	
8			180"(4572mm)	TCRA-54J0-					S	GG4	4923.81	5965.33	5098.65	6140.17	8799.21	10518.57	9729.67	11642.23	
8			216"(5486mm)	TCRA-54M6-					S	GG4	5339.73	6818.52	5537.25	7016.04	10230.24	11933.34	11353.43	13307.43	
2	36"(914mm)	30"(762mm)	48"(1219mm)	TCRA-3048-					SNGG6		\$1112.30	\$1326.18	\$1190.54	\$1404.42	\$ 1787.76	\$ 2052.30	\$ 1944.70	\$ 2243.99	
2			60"(1524mm)	TCRA-3060-					S	GG6	1171.85	1427.65	1254.29	1510.09	1976.35	2295.15	2167.77	2529.77	
2			72"(1829mm)	TCRA-3072-					S	GG6	1232.09	1533.93	1318.73	1620.57	2167.05	2545.43	2393.40	2824.26	
2	36"(914mm)	36"(914mm)	60"(1524mm)	TCRA-3660-					S	GG6	\$1226.75	\$1496.83	\$1313.39	\$1583.47	\$ 2150.77	\$ 2488.05	\$ 2373.65	\$ 2757.01	
2			72"(1829mm)	TCRA-3672-					S	GG6	1297.66	1614.81	1389.34	1706.49	2375.42	2773.61	2639.32	3093.08	
2	42"(1067mm)	30"(762mm)	48"(1219mm)	TCRA-3048-					SNG	7	\$1138.56	\$1352.44	\$1216.80	\$1430.68	\$ 1814.02	\$ 2078.56	\$ 1970.96	\$ 2270.25	
2			60"(1524mm)	TCRA-3060-					S	G 7	1198.11	1453.91	1280.55	1536.35	2002.61	2321.41	2194.03	2556.03	
2			72"(1829mm)	TCRA-3072-					S	G 7	1258.35	1560.19	1344.99	1646.83	2193.31	2571.69	2419.66	2850.52	
2	42"(1067mm)	36"(914mm)	60"(1524mm)	TCRA-3660-					S	G 7	\$1253.01	\$1523.09	\$1339.65	\$1609.73	\$ 2177.03	\$ 2514.31	\$ 2399.91	\$ 2783.27	
2			72"(1829mm)	TCRA-3672-					S	G 7	1323.92	1641.07	1415.60	1732.75	2401.68	2799.87	2665.58	3119.34	

Jive Table — Bridge Base

Rectangle – Laminate or Wood

No. of Columns	Height	Depth	Width	Number						Laminate A		Laminate B		Wood Group A		Wood Group B	
					①	②	③	④	⑤	J	F	J	F	K	U	K	U
Base — Power Ready — No Cutout																	
2	16"(406mm)	30"(762mm)	48"(1219mm)	TCRA-3048-						SNGK1							
2			60"(1524mm)	TCRA-3060-						S							
2			72"(1829mm)	TCRA-3072-						S							
2	16"(406mm)	36"(914mm)	60"(1524mm)	TCRA-3660-						S							
2			72"(1829mm)	TCRA-3672-						S							
2	20"(508mm)	30"(762mm)	48"(1219mm)	TCRA-3048-						SNGK2							
2			60"(1524mm)	TCRA-3060-						S							
2			72"(1829mm)	TCRA-3072-						S							
2	20"(508mm)	36"(914mm)	60"(1524mm)	TCRA-3660-						S							
2			72"(1829mm)	TCRA-3672-						S							
2	29"(737mm)	30"(762mm)	48"(1219mm)	TCRA-3048-						SNG							
2			60"(1524mm)	TCRA-3060-						S							
2			72"(1829mm)	TCRA-3072-						S							
2	20"(508mm)	36"(914mm)	60"(1524mm)	TCRA-3660-						S							
2			72"(1829mm)	TCRA-3672-						S							
2	29"(737mm)	30"(762mm)	48"(1219mm)	TCRA-3048-						SNG							
2			60"(1524mm)	TCRA-3060-						S							
2			72"(1829mm)	TCRA-3072-						S							
2	29"(737mm)	36"(914mm)	60"(1524mm)	TCRA-3660-						S							
2			72"(1829mm)	TCRA-3672-						S							
3	29"(737mm)	42"(1067mm)	84"(2134mm)	TCRA-4284-						SNGK4							
3			96"(2438mm)	TCRA-4296-						SNGK4							
3	29"(737mm)	48"(1219mm)	96"(2438mm)	TCRA-4896-						SNGK4							
3			108"(2743mm)	TCRA-48A8-						SNGK4							
3			120"(3048mm)	TCRA-48C0-						S							
6	29"(737mm)	54"(1372mm)	96"(2438mm)	TCRA-5496-						SNGK4							
6			108"(2743mm)	TCRA-54A8-						SNGK4							
6			120"(3048mm)	TCRA-54C0-						S							
6			144"(3658mm)	TCRA-54E4-						S							
8			180"(4572mm)	TCRA-54J0-						S							
8			216"(5486mm)	TCRA-54M6-						S							
2	36"(914mm)	30"(762mm)	48"(1219mm)	TCRA-3048-						SNGK6							
2			60"(1524mm)	TCRA-3060-						S							
2			72"(1829mm)	TCRA-3072-						S							
2	36"(914mm)	36"(914mm)	60"(1524mm)	TCRA-3660-						S							
2			72"(1829mm)	TCRA-3672-						S							
2	42"(1067mm)	30"(762mm)	48"(1219mm)	TCRA-3048-						SNG							
2			60"(1524mm)	TCRA-3060-						S							
2			72"(1829mm)	TCRA-3072-						S							
2	42"(1067mm)	36"(914mm)	60"(1524mm)	TCRA-3660-						S							
2			72"(1829mm)	TCRA-3672-						S							

This page intentionally blank

Jive Table — Bridge Base

Racetrack – Laminate or Wood

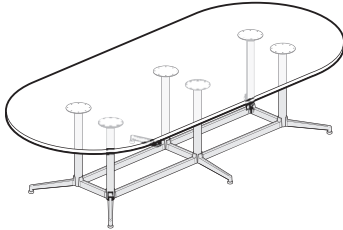
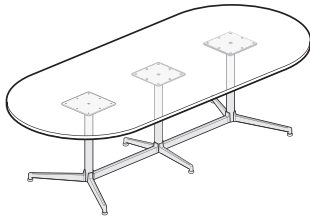

TCRT-SNG

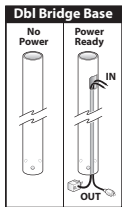
**Features**

- Includes 1 3/16" (30mm) thick standard top, base, adjustable glides or casters and hardware.
- Standard table heights are 16" (406mm), 20" (508mm), 29" (737mm), 36" (914mm) and 42" (1067mm).
- Laminate top with knife edge or 3mm edgeband edges or wood veneer top with 3mm wood edgeband or knife edge.
- Casters:
 - Two locking and two non-locking casters with 5/8" (16mm) adjustment.
 - Standard in black.
- Glides:
 - 5/8" (16mm) adjustment.
 - Standard in black.
- Casters and glides are not interchangeable.
- Ships unassembled.

Specification Tips

- Tables with more than one piece:
 - 144" (3658mm) and 180" (4572mm) width top has two pieces;
 - 216" (5486mm) top has three pieces.
- **Specifying a cutout does not automatically include a Power Ready base.**
- Factory installed cutout is available for tables 72" (1829mm) wide or less:
 - Specify the (F) option for a Center, Single-Sided/4 outlet Flip Top Unit
 - Specify the (J) option for a Center, Single-Sided/6 outlet Flip Top Unit
 - Specify the (M) option for a Center, Double-Sided/8 outlet Flip Top Unit
 - Specify the (Q) option for a Center, Double-Sided/12 outlet Flip Top Unit
- Factory installed cutout is available for:
 - Tables greater than 72" wide **except 84" (2134mm), 96" (2438mm) and 108" (2743mm) wide:**
 - Specify the (V) option for Left/Right, Single-Sided/4 outlet Flip Top Unit
 - Specify the (K) option for Left/Right, Single-Sided/6 outlet Flip Top Unit
 - Exception:
 - 54" (1372mm) depth x 96" (2438mm) wide will accept V and K option cutouts.
- Power Ready Base:
 - Allows for cord management through one of the Bridge Base Base columns.
 - Tables with 30" (762mm), 36" (914mm), 42" (1067mm) and 48" (1219mm) depths will have 2 or 3 columns. Powered leg location with:
 - Two columns is determined during installation.
 - Three columns is always centered.
 - Tables with 54" (1372mm) depths will have 4 or more columns. Powered leg location with 6 and 8 columns determined at installation of interior legs.
 - Casters and Glides:
 - Specify the (J) option for Casters on the Power Ready base (only available with two column tables 29" (737mm) or 42" (1067mm) high)
 - Specify the (K) option for Glides on the Power Ready base (available on 16" (406mm), 20" (508mm), 29" (737mm), 36" (914mm) and 42" (1067mm) high tables)
 - Flip Top Unit circuit breaker plug fits Power Ready Base opening.
- **Power cord length determines the distance to building power source.**
- Separately specified:
 - Horizontal and Vertical Wire Management
 - Power and Data Components
 - Accessories
- Refer to Specification Guide:
 - Accessory placement and compatibility.
 - Seating capacities and leg locations.
 - Information on electrical components compatible with factory cut opening.
 - Power Ready base cable capacity.
- Application may require approval of local authority having jurisdiction (AHJ); ensure compliance before placing orders and installation.

To Order, Specify:

1) Product number, including:

1 Surface Option:

- L** Laminate
- W** Wood

2 Edge Option:

Laminate:

- J** Edgeband
- F** Knife

Wood:

- K** Edgeband
- U** Knife

3 Cutout:

- N** No Cutout
- F** Center, Single-Sided/4 outlets, add **\$33.13** list
- J** Center, Single-Sided/6 outlets, add **\$33.13** list
- M** Center, Double-Sided/8 outlets, add **\$33.13** list
- Q** Center, Double-Sided/12 outlets, add **\$33.13** list
- V** Left/Right, Single-Sided/4 outlets, add **\$33.13** list
- K** Left/Right, Single-Sided/6 outlets, add **\$33.13** list

4 Base and Wire Management Option:

Base - No Power:

- C** Casters, add **\$15.60** list (29" and 42" Heights Only)
- G** Glides

Base - Power Ready:

- J** Casters, add **\$15.60** list (29" and 42" Heights Only)
- K** Glides

5 Base Finish Option:

- A** Painted
- B** Polished, add **\$46.80** list

- 2) Laminate surface color or wood finish color.
- 3) Edgeband trim color (laminite only).
- 4) Base trim color.

Note: **\$41.60** upcharge list for Metallic trim colors.

Jive Table — Bridge Base

Racetrack – Laminate or Wood

No. of Columns	Height	Depth	Width	Number	① ② ③ ④ ⑤	Laminate A		Laminate B		Wood Group A		Wood Group B		
						J	F	J	F	K	U	K	U	
Base — No Power — No Cutout														
2	16"(406mm)	30"(762mm)	48"(1219mm)	TCRT-3048-	■ ■ ■ ■ ■	SNGG1	\$1033.52	\$1247.40	\$1111.76	\$1325.64	\$ 1708.98	\$ 1973.52	\$ 1865.92	\$ 2165.21
2			60"(1524mm)	TCRT-3060-	■ ■ ■ ■ ■	S ■ GG1	1093.07	1348.87	1175.51	1431.31	1897.57	2216.37	2088.99	2450.99
2			72"(1829mm)	TCRT-3072-	■ ■ ■ ■ ■	S ■ GG1	1153.31	1455.15	1239.95	1541.79	2088.27	2466.65	2314.62	2745.48
2	16"(406mm)	36"(914mm)	60"(1524mm)	TCRT-3660-	■ ■ ■ ■ ■	S ■ GG1	\$1147.97	\$1418.05	\$1234.61	\$1504.69	\$ 2071.99	\$ 2409.27	\$ 2294.87	\$ 2678.23
2			72"(1829mm)	TCRT-3672-	■ ■ ■ ■ ■	S ■ GG1	1218.88	1536.03	1310.56	1627.71	2296.64	2694.83	2560.54	3014.30
2	20"(508mm)	30"(762mm)	48"(1219mm)	TCRT-3048-	■ ■ ■ ■ ■	SNGG2	\$1086.04	\$1299.92	\$1164.28	\$1378.16	\$ 1761.50	\$ 2026.04	\$ 1918.44	\$ 2217.73
2			60"(1524mm)	TCRT-3060-	■ ■ ■ ■ ■	S ■ GG2	1145.59	1401.39	1228.03	1483.83	1950.09	2268.89	2141.51	2503.51
2			72"(1829mm)	TCRT-3072-	■ ■ ■ ■ ■	S ■ GG2	1205.83	1507.67	1292.47	1594.31	2140.79	2519.17	2367.14	2798.00
2	20"(508mm)	36"(914mm)	60"(1524mm)	TCRT-3660-	■ ■ ■ ■ ■	S ■ GG2	\$1200.49	\$1470.57	\$1287.13	\$1557.21	\$ 2124.51	\$ 2461.79	\$ 2347.39	\$ 2730.75
2			72"(1829mm)	TCRT-3672-	■ ■ ■ ■ ■	S ■ GG2	1271.40	1588.55	1363.08	1680.23	2349.16	2747.35	2613.06	3066.82
2	29"(737mm)	30"(762mm)	48"(1219mm)	TCRT-3048-	■ ■ ■ ■ ■	SNG 4	\$1086.04	\$1299.92	\$1164.28	\$1378.16	\$ 1761.50	\$ 2026.04	\$ 1918.44	\$ 2217.73
2			60"(1524mm)	TCRT-3060-	■ ■ ■ ■ ■	S ■ G 4	1145.59	1401.39	1228.03	1483.83	1950.09	2268.89	2141.51	2503.51
2			72"(1829mm)	TCRT-3072-	■ ■ ■ ■ ■	S ■ G 4	1205.83	1507.67	1292.47	1594.31	2140.79	2519.17	2367.14	2798.00
2	29"(737mm)	36"(914mm)	60"(1524mm)	TCRT-3660-	■ ■ ■ ■ ■	S ■ G 4	\$1200.49	\$1470.57	\$1287.13	\$1557.21	\$ 2124.51	\$ 2461.79	\$ 2347.39	\$ 2730.75
2			72"(1829mm)	TCRT-3672-	■ ■ ■ ■ ■	S ■ G 4	1271.40	1588.55	1363.08	1680.23	2349.16	2747.35	2613.06	3066.82
3	29"(737mm)	42"(1067mm)	84"(2134mm)	TCRT-4284-	■ ■ ■ ■ ■	SNGG4	\$2558.17	\$2942.83	\$2660.77	\$3045.43	\$ 3957.15	\$ 4442.71	\$ 4306.16	\$ 4860.92
3			96"(2438mm)	TCRT-4296-	■ ■ ■ ■ ■	SNGG4	2641.13	3082.12	2749.61	3190.60	4219.96	4778.40	4616.99	5255.98
3	29"(737mm)	48"(1219mm)	108"(2743mm)	TCRT-48A8-	■ ■ ■ ■ ■	SNGG4	\$2822.38	\$3342.19	\$2944.30	\$3464.11	\$ 4795.08	\$ 5455.54	\$ 5296.40	\$ 6053.31
3			120"(3048mm)	TCRT-48C0-	■ ■ ■ ■ ■	S ■ GG4	2917.40	3502.78	3046.04	3631.42	5096.06	5841.37	5652.38	6507.37
6	29"(737mm)	54"(1372mm)	96"(2438mm)	TCRT-5496-	■ ■ ■ ■ ■	SNGG4	\$2920.01	\$3395.72	\$3041.93	\$3517.64	\$ 4877.52	\$ 5480.91	\$ 5374.02	\$ 6064.97
6			108"(2743mm)	TCRT-54A8-	■ ■ ■ ■ ■	SNGG4	3025.01	3563.21	3154.49	3692.69	5210.33	5894.59	5767.48	6551.90
6			120"(3048mm)	TCRT-54C0-	■ ■ ■ ■ ■	SNGG4	3130.71	3735.51	3267.75	3872.55	5545.25	6315.70	6163.50	7047.54
6			144"(3658mm)	TCRT-54E4-	■ ■ ■ ■ ■	S ■ GG4	4458.70	5251.06	4610.86	5403.22	7629.41	9054.24	8371.19	9938.96
8			180"(4572mm)	TCRT-54J0-	■ ■ ■ ■ ■	S ■ GG4	4923.81	5965.33	5098.65	6140.17	8799.21	10518.57	9729.67	11642.23
8			216"(5486mm)	TCRT-54M6-	■ ■ ■ ■ ■	S ■ GG4	5339.73	6818.52	5537.25	7016.04	10230.24	11933.34	11353.43	13307.43
2	36"(914mm)	30"(762mm)	48"(1219mm)	TCRT-3048-	■ ■ ■ ■ ■	SNGG6	\$1112.30	\$1326.18	\$1190.54	\$1404.42	\$ 1787.76	\$ 2052.30	\$ 1944.70	\$ 2243.99
2			60"(1524mm)	TCRT-3060-	■ ■ ■ ■ ■	S ■ GG6	1171.85	1427.65	1254.29	1510.09	1976.35	2295.15	2167.77	2529.77
2			72"(1829mm)	TCRT-3072-	■ ■ ■ ■ ■	S ■ GG6	1232.09	1533.93	1318.73	1620.57	2167.05	2545.43	2393.40	2824.26
2	36"(914mm)	36"(914mm)	60"(1524mm)	TCRT-3660-	■ ■ ■ ■ ■	S ■ GG6	\$1226.75	\$1496.83	\$1313.39	\$1583.47	\$ 2150.77	\$ 2488.05	\$ 2373.65	\$ 2757.01
2			72"(1829mm)	TCRT-3672-	■ ■ ■ ■ ■	S ■ GG6	1297.66	1614.81	1389.34	1706.49	2375.42	2773.61	2639.32	3093.08
2	42"(1067mm)	30"(762mm)	48"(1219mm)	TCRT-3048-	■ ■ ■ ■ ■	S ■ G 7	\$1138.56	\$1352.44	\$1216.80	\$1430.68	\$ 1814.02	\$ 2078.56	\$ 1970.96	\$ 2270.25
2			60"(1524mm)	TCRT-3060-	■ ■ ■ ■ ■	S ■ G 7	1198.11	1453.91	1280.55	1536.35	2002.61	2321.41	2194.03	2556.03
2			72"(1829mm)	TCRT-3072-	■ ■ ■ ■ ■	S ■ G 7	1258.35	1560.19	1344.99	1646.83	2193.31	2571.69	2419.66	2850.52
2	42"(1067mm)	36"(914mm)	60"(1524mm)	TCRT-3660-	■ ■ ■ ■ ■	S ■ G 7	\$1253.01	\$1523.09	\$1339.65	\$1609.73	\$ 2177.03	\$ 2514.31	\$ 2399.91	\$ 2783.27
2			72"(1829mm)	TCRT-3672-	■ ■ ■ ■ ■	S ■ G 7	1323.92	1641.07	1415.60	1732.75	2401.68	2799.87	2665.58	3119.34

Jive Table — Bridge Base

Racetrack – Laminate or Wood

No. of Columns	Height	Depth	Width	Number	① ② ③ ④ ⑤	Laminate A		Laminate B		Wood Group A		Wood Group B	
						J	F	J	F	K	U	K	U
Base — Power Ready — No Cutout													
2	16"(406mm)	30"(762mm)	48"(1219mm)	TCRT-3048-	SNGK1	\$1053.52	\$1267.40	\$1131.76	\$1345.64	\$ 1728.98	\$ 1993.52	\$ 1885.92	\$ 2185.21
2			60"(1524mm)	TCRT-3060-	S GK1	1113.07	1368.87	1195.51	1451.31	1917.57	2236.37	2108.99	2470.99
2			72"(1829mm)	TCRT-3072-	S GK1	1173.31	1475.15	1259.95	1561.79	2108.27	2486.65	2334.62	2765.48
2	16"(406mm)	36"(914mm)	60"(1524mm)	TCRT-3660-	S GK1	\$1167.97	\$1438.05	\$1254.61	\$1524.69	\$ 2091.99	\$ 2429.27	\$ 2314.87	\$ 2698.23
2			72"(1829mm)	TCRT-3672-	S GK1	1238.88	1556.03	1330.56	1647.71	2316.64	2714.83	2580.54	3034.30
2	20"(508mm)	30"(762mm)	48"(1219mm)	TCRT-3048-	SNGK2	\$1106.04	\$1319.92	\$1184.28	\$1398.16	\$ 1781.50	\$ 2046.04	\$ 1938.44	\$ 2237.73
2			60"(1524mm)	TCRT-3060-	S GK2	1165.59	1421.39	1248.03	1503.83	1970.09	2288.89	2161.51	2523.51
2			72"(1829mm)	TCRT-3072-	S GK2	1225.83	1527.67	1312.47	1614.31	2160.79	2539.17	2387.14	2818.00
2	20"(508mm)	36"(914mm)	60"(1524mm)	TCRT-3660-	S GK2	\$1220.49	\$1490.57	\$1307.13	\$1577.21	\$ 2144.51	\$ 2481.79	\$ 2367.39	\$ 2750.75
2			72"(1829mm)	TCRT-3672-	S GK2	1291.40	1608.55	1383.08	1700.23	2369.16	2767.35	2633.06	3086.82
2	29"(737mm)	30"(762mm)	48"(1219mm)	TCRT-3048-	SNG 4	\$1106.04	\$1319.92	\$1184.28	\$1398.16	\$ 1781.50	\$ 2046.04	\$ 1938.44	\$ 2237.73
2			60"(1524mm)	TCRT-3060-	S G 4	1165.59	1421.39	1248.03	1503.83	1970.09	2288.89	2161.51	2523.51
2			72"(1829mm)	TCRT-3072-	S G 4	1225.83	1527.67	1312.47	1614.31	2160.79	2539.17	2387.14	2818.00
2	29"(737mm)	36"(914mm)	60"(1524mm)	TCRT-3660-	S G 4	\$1220.49	\$1490.57	\$1307.13	\$1577.21	\$ 2144.51	\$ 2481.79	\$ 2367.39	\$ 2750.75
2			72"(1829mm)	TCRT-3672-	S G 4	1291.40	1608.55	1383.08	1700.23	2369.16	2767.35	2633.06	3086.82
3	29"(737mm)	42"(1067mm)	84"(2134mm)	TCRT-4284-	SNGK4	\$2578.17	\$2962.83	\$2680.77	\$3065.43	\$ 3977.15	\$ 4462.71	\$ 4326.16	\$ 4880.92
3			96"(2438mm)	TCRT-4296-	SNGK4	2661.13	3102.12	2769.61	3210.60	4239.96	4798.40	4636.99	5275.98
3	29"(737mm)	48"(1219mm)	108"(2743mm)	TCRT-48A8-	SNGK4	\$2842.38	\$3362.19	\$2964.30	\$3484.11	\$ 4815.08	\$ 5475.54	\$ 5316.40	\$ 6073.31
3			120"(3048mm)	TCRT-48C0-	S GK4	2937.40	3522.78	3066.04	3651.42	5116.06	5861.37	5672.38	6527.37
6	29"(737mm)	54"(1372mm)	96"(2438mm)	TCRT-5496-	SNGK4	\$2940.01	\$3415.72	\$3061.93	\$3537.64	\$ 4897.52	\$ 5500.91	\$ 5394.02	\$ 6084.97
6			108"(2743mm)	TCRT-54A8-	SNGK4	3045.01	3583.21	3174.49	3712.69	5230.33	5914.59	5787.48	6571.90
6			120"(3048mm)	TCRT-54C0-	SNGK4	3150.71	3755.51	3287.75	3892.55	5565.25	6335.70	6183.50	7067.54
6			144"(3658mm)	TCRT-54E4-	S GK4	4478.70	5271.06	4630.86	5423.22	7649.41	9074.24	8391.19	9958.96
8			180"(4572mm)	TCRT-54J0-	S GK4	4943.81	5985.33	5118.65	6160.17	8819.21	10538.57	9749.67	11662.23
8			216"(5486mm)	TCRT-54M6-	S GK4	5359.73	6838.52	5557.25	7036.04	10250.24	11953.34	11373.43	13327.43
2	36"(914mm)	30"(762mm)	48"(1219mm)	TCRT-3048-	SNGK6	\$1132.30	\$1346.18	\$1210.54	\$1424.42	\$ 1807.76	\$ 2072.30	\$ 1964.70	\$ 2263.99
2			60"(1524mm)	TCRT-3060-	S GK6	1191.85	1447.65	1274.29	1530.09	1996.35	2315.15	2187.77	2549.77
2			72"(1829mm)	TCRT-3072-	S GK6	1252.09	1553.93	1338.73	1640.57	2187.05	2565.43	2413.40	2844.26
2	36"(914mm)	36"(914mm)	60"(1524mm)	TCRT-3660-	S GK6	\$1246.75	\$1516.83	\$1333.39	\$1603.47	\$ 2170.77	\$ 2508.05	\$ 2393.65	\$ 2777.01
2			72"(1829mm)	TCRT-3672-	S GK6	1317.66	1634.81	1409.34	1726.49	2395.42	2793.61	2659.32	3113.08
2	42"(1067mm)	30"(762mm)	48"(1219mm)	TCRT-3048-	S G 7	\$1158.56	\$1372.44	\$1236.80	\$1450.68	\$ 1834.02	\$ 2098.56	\$ 1990.96	\$ 2290.25
2			60"(1524mm)	TCRT-3060-	S G 7	1218.11	1473.91	1300.55	1556.35	2022.61	2341.41	2214.03	2576.03
2			72"(1829mm)	TCRT-3072-	S G 7	1278.35	1580.19	1364.99	1666.83	2213.31	2591.69	2439.66	2870.52
2	42"(1067mm)	36"(914mm)	60"(1524mm)	TCRT-3660-	S G 7	\$1273.01	\$1543.09	\$1359.65	\$1629.73	\$ 2197.03	\$ 2534.31	\$ 2419.91	\$ 2803.27
2			72"(1829mm)	TCRT-3672-	S G 7	1343.92	1661.07	1435.60	1752.75	2421.68	2819.87	2685.58	3139.34

Jive Table — Bridge Base

Half Racetrack – Laminate or Wood

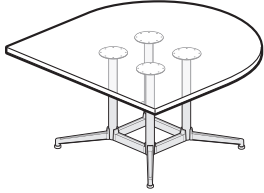

TCHT-SNG

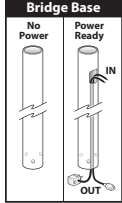

Features

- Includes 1 3/16" (30mm) thick standard top, base, adjustable glides or casters and hardware.
- Standard table heights are 29" (737mm) and 42" (1067mm).
- Laminate top with knife edge or 3mm edgeband edges or wood veneer top with 3mm wood edgeband or knife edge.
- Casters:
 - Four locking casters with 5/8" (16mm) adjustment.
 - Standard in black.
- Glides:
 - 5/8" (16mm) adjustment.
 - Standard in black.
- Casters and glides are not interchangeable.
- Ships unassembled.

Specification Tips

- Edge choice allows a flat seam between tables.
- **Specifying a cutout does not automatically include a Power Ready base.**
- Factory installed cutout available on 54" (1372mm) and 60" (1524mm) deep tables:
 - Specify the (F) option for a Center, Single-Sided/4 outlet Flip Top Unit
 - Specify the (J) option for a Center, Single-Sided/6 outlet Flip Top Unit
 - Specify the (M) option for a Center, Double-Sided/8 outlet Flip Top Unit (only available on 60" (1524mm) deep tables)
- Power Ready Base:
 - Allows for cord management through one of the Bridge Base Base columns.
 - Tables with two column Powered leg location is determined during installation.
 - Tables with 54" (1372mm) and 60" (1524mm) depths will have 4 columns. **Powered leg location is determined during installation.**
 - Casters and Glides:
 - Specify the (J) option for Casters on the Power Ready base (only available with two column tables 29" (737mm) or 42" (1067mm) high)
 - Specify the (K) option for Glides on the Power Ready base
 - Flip Top Unit circuit breaker plug fits Power Ready Base opening.
- **Power cord length determines the distance to building power source.**
- Separately specified:
 - Ganging Mechanism - Recommended for use with power between tables.
 - Horizontal and Vertical Wire Management
 - Power and Data Components
 - Accessories
- Refer to Specification Guide:
 - Accessory placement and compatibility.
 - Seating capacities and leg locations.
 - Information on electrical components compatible with factory cut opening.
 - Power Ready base cable capacity.
- Application may require approval of local authority having jurisdiction (AHJ); ensure compliance before placing orders and installation.

To Order, Specify:

- 1) Product number, including:

1 Surface Option:

- L** Laminate
- W** Wood

2 Edge Option:

Laminate:

- J** Edgeband
- F** Knife

Wood:

- K** Edgeband
- U** Knife

3 Cutout:

- N** No Cutout
- F** Center, Single-Sided/4 outlets, add **\$33.13** list
- J** Center, Single-Sided/6 outlets, add **\$33.13** list
- M** Center, Double-Sided/8 outlets, add **\$33.13** list

4 Base and Wire Management Option:

Base - No Power:

- C** Casters, add **\$15.60** list
- G** Glides

Base - Power Ready:

- J** Casters, add **\$15.60** list
- K** Glides

5 Base Finish Option:

- A** Painted
- B** Polished, add **\$46.80** list

- 2) Laminate surface color or wood finish color.
- 3) Edgeband trim color (laminated only).
- 4) Base trim color.

Note: **\$41.60** upcharge list for Metallic trim colors.

Jive Table — Bridge Base

Half Racetrack – Laminate or Wood

No. of Columns	Height	Depth	Width	Number	① ② ③ ④ ⑤	Laminate A		Laminate B		Wood Group A		Wood Group B	
						J	F	J	F	K	U	K	U
Base — No Power — No Cutout													
2	29"(737mm)	42"(1067mm)	42"(1067mm)	TCHT-4242-	■ ■ S ■ G ■ 4 ■	\$1184.45	\$1425.97	\$1198.31	\$1439.83	\$1631.51	\$1967.95	\$1752.02	\$2135.00
2		48"(1219mm)	48"(1219mm)	TCHT-4848-	■ ■ S ■ G ■ 4 ■	1268.00	1538.08	1288.16	1558.24	1896.80	2357.70	2065.28	2593.54
4		54"(1372mm)	54"(1372mm)	TCHT-5454-	■ ■ S ■ GG4 ■	1362.05	1660.69	1389.35	1687.99	2195.51	2801.46	2417.94	3115.61
4		60"(1524mm)	60"(1524mm)	TCHT-6060-	■ ■ S ■ GG4 ■	1466.60	1793.80	1501.88	1829.08	2527.64	3299.90	2810.00	3702.00
2	42"(1067mm)	42"(1067mm)	42"(1067mm)	TCHT-4242-	■ ■ S ■ G ■ 7 ■	\$1288.45	\$1529.97	\$1302.31	\$1543.83	\$1735.51	\$2071.95	\$1856.02	\$2239.00
2		48"(1219mm)	48"(1219mm)	TCHT-4848-	■ ■ S ■ G ■ 7 ■	1372.00	1642.08	1392.16	1662.24	2000.80	2461.70	2169.28	2697.54
4		54"(1372mm)	54"(1372mm)	TCHT-5454-	■ ■ S ■ GG7 ■	1466.05	1764.69	1493.35	1791.99	2299.51	2905.46	2521.94	3219.61
4		60"(1524mm)	60"(1524mm)	TCHT-6060-	■ ■ S ■ GG7 ■	1570.60	1897.80	1605.88	1933.08	2631.64	3403.90	2914.00	3806.00
Base — Power Ready — No Cutout													
2	29"(737mm)	42"(1067mm)	42"(1067mm)	TCHT-4242-	■ ■ S ■ G ■ 4 ■	\$1204.45	\$1445.97	\$1218.31	\$1459.83	\$1651.51	\$1987.95	\$1772.02	\$2155.00
2		48"(1219mm)	48"(1219mm)	TCHT-4848-	■ ■ S ■ G ■ 4 ■	1288.00	1558.08	1308.16	1578.24	1916.80	2377.70	2085.28	2613.54
4		54"(1372mm)	54"(1372mm)	TCHT-5454-	■ ■ S ■ GK4 ■	1382.05	1680.69	1409.35	1707.99	2215.51	2821.46	2437.94	3135.61
4		60"(1524mm)	60"(1524mm)	TCHT-6060-	■ ■ S ■ GK4 ■	1486.60	1813.80	1521.88	1849.08	2547.64	3319.90	2830.00	3722.00
2	42"(1067mm)	42"(1067mm)	42"(1067mm)	TCHT-4242-	■ ■ S ■ G ■ 7 ■	\$1308.45	\$1549.97	\$1322.31	\$1563.83	\$1755.51	\$2091.95	\$1876.02	\$2259.00
2		48"(1219mm)	48"(1219mm)	TCHT-4848-	■ ■ S ■ G ■ 7 ■	1392.00	1662.08	1412.16	1682.24	2020.80	2481.70	2189.28	2717.54
4		54"(1372mm)	54"(1372mm)	TCHT-5454-	■ ■ S ■ GK7 ■	1486.05	1784.69	1513.35	1811.99	2319.51	2925.46	2541.94	3239.61
4		60"(1524mm)	60"(1524mm)	TCHT-6060-	■ ■ S ■ GK7 ■	1590.60	1917.80	1625.88	1953.08	2651.64	3423.90	2934.00	3826.00

Jive Table — Bridge Base

Pebble Half – Laminate or Wood

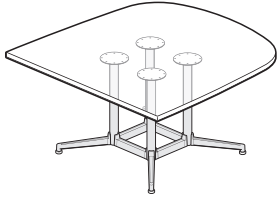

TCHP-SNG

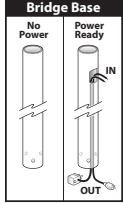

Features

- Includes 1 3/16" (30mm) thick standard top, base, adjustable glides or casters and hardware.
- Standard table heights are 29" (737mm) and 42" (1067mm).
- Laminate top with knife edge or 3mm edgeband edges or wood veneer top with 3mm wood edgeband or knife edge.
- Casters:
 - Four locking casters with 5/8" (16mm) adjustment.
 - Standard in black.
- Glides:
 - 5/8" (16mm) adjustment.
 - Standard in black.
- Casters and glides are not interchangeable.
- Ships unassembled.

Specification Tips

- Edge choice allows a flat seam between tables.
- **Specifying a cutout does not automatically include a Power Ready base.**
- Factory installed cutout available on 54" (1372mm) and 60" (1524mm) deep tables:
 - Specify the (F) option for a Center, Single-Sided/4 outlet Flip Top Unit
 - Specify the (J) option for a Center, Single-Sided/6 outlet Flip Top Unit
 - Specify the (M) option for a Center, Double-Sided/8 outlet Flip Top Unit (only available on 60" (1524mm) deep tables)
- Power Ready Base:
 - Allows for cord management through one of the Bridge Base Base columns.
 - Tables with two column Powered leg location is determined during installation.
 - Tables with 54" (1372mm) and 60" (1524mm) depths will have 4 columns. Powered leg location is determined during installation.
 - Casters and Glides:
 - Specify the (J) option for Casters on the Power Ready base (only available with two column tables 29" (737mm) or 42" (1067mm) high)
 - Specify the (K) option for Glides on the Power Ready base
 - Flip Top Unit circuit breaker plug fits Power Ready Base opening.
- **Power cord length determines the distance to building power source.**
- Separately specified:
 - Ganging Mechanism - Recommended for use with power between tables.
 - Horizontal and Vertical Wire Management
 - Power and Data Components
 - Accessories
- Refer to Specification Guide:
 - Accessory placement and compatibility.
 - Seating capacities and leg locations.
 - Information on electrical components compatible with factory cut opening.
 - Power Ready base cable capacity.
- Application may require approval of local authority having jurisdiction (AHJ); ensure compliance before placing orders and installation.

To Order, Specify:

1) Product number, including:

1 Surface Option:

- L** Laminate
- W** Wood

2 Edge Option:

Laminate:

- J** Edgeband
- F** Knife

Wood:

- K** Edgeband
- U** Knife

3 Cutout:

- N** No Cutout
- F** Center, Single-Sided/4 outlets, add **\$33.13** list
- J** Center, Single-Sided/6 outlets, add **\$33.13** list
- M** Center, Double-Sided/8 outlets, add **\$33.13** list

4 Base and Wire Management Option:

Base - No Power:

- C** Casters, add **\$15.60** list
- G** Glides

Base - Power Ready:

- J** Casters, add **\$15.60** list
- K** Glides

5 Base Finish Option:

- A** Painted
- B** Polished, add **\$46.80** list

2) Laminate surface color or wood finish color.

3) Edgeband trim color (laminated only).

4) Base trim color.

Note: **\$41.60** upcharge list for Metallic trim colors.

Jive Table — Bridge Base

Pebble Half – Laminate or Wood

No. of Columns	Height	Depth	Width	Number	① ② ③ ④ ⑤	Laminate A		Laminate B		Wood Group A		Wood Group B		
						J	F	J	F	K	U	K	U	
Base — No Power — No Cutout														
2	29"(737mm)	42"(1067mm)	42"(1067mm)	TCHP-4242-	■ ■ SNG	4 ■	\$1184.45	\$1425.97	\$1198.31	\$1439.83	\$1631.51	\$1967.95	\$1752.02	\$2135.00
2		48"(1219mm)	48"(1219mm)	TCHP-4848-	■ ■ SNG	4 ■	1268.00	1538.08	1288.16	1558.24	1896.80	2357.70	2065.28	2593.54
4		54"(1372mm)	54"(1372mm)	TCHP-5454-	■ ■ S	G ■ 4 ■	1362.05	1660.69	1389.35	1687.99	2195.51	2801.46	2417.94	3115.61
4		60"(1524mm)	60"(1524mm)	TCHP-6060-	■ ■ S	G ■ 4 ■	1466.60	1793.80	1501.88	1829.08	2527.64	3299.90	2810.00	3702.00
2	42"(1067mm)	42"(1067mm)	42"(1067mm)	TCHP-4242-	■ ■ SNG	7 ■	\$1288.45	\$1529.97	\$1302.31	\$1543.83	\$1735.51	\$2071.95	\$1856.02	\$2239.00
2		48"(1219mm)	48"(1219mm)	TCHP-4848-	■ ■ SNG	7 ■	1372.00	1642.08	1392.16	1662.24	2000.80	2461.70	2169.28	2697.54
4		54"(1372mm)	54"(1372mm)	TCHP-5454-	■ ■ S	G ■ 7 ■	1466.05	1764.69	1493.35	1791.99	2299.51	2905.46	2521.94	3219.61
4		60"(1524mm)	60"(1524mm)	TCHP-6060-	■ ■ S	G ■ 7 ■	1570.60	1897.80	1605.88	1933.08	2631.64	3403.90	2914.00	3806.00
Base — Power Ready — No Cutout														
2	29"(737mm)	42"(1067mm)	42"(1067mm)	TCHP-4242-	■ ■ SNG	4 ■	\$1204.45	\$1445.97	\$1218.31	\$1459.83	\$1651.51	\$1987.95	\$1772.02	\$2155.00
2		48"(1219mm)	48"(1219mm)	TCHP-4848-	■ ■ SNG	4 ■	1288.00	1558.08	1308.16	1578.24	1916.80	2377.70	2085.28	2613.54
4		54"(1372mm)	54"(1372mm)	TCHP-5454-	■ ■ S	G ■ 4 ■	1382.05	1680.69	1409.35	1707.99	2215.51	2821.46	2437.94	3135.61
4		60"(1524mm)	60"(1524mm)	TCHP-6060-	■ ■ S	G ■ 4 ■	1486.60	1813.80	1521.88	1849.08	2547.64	3319.90	2830.00	3722.00
2	42"(1067mm)	42"(1067mm)	42"(1067mm)	TCHP-4242-	■ ■ SNG	7 ■	\$1308.45	\$1549.97	\$1322.31	\$1563.83	\$1755.51	\$2091.95	\$1876.02	\$2259.00
2		48"(1219mm)	48"(1219mm)	TCHP-4848-	■ ■ SNG	7 ■	1392.00	1662.08	1412.16	1682.24	2020.80	2481.70	2189.28	2717.54
4		54"(1372mm)	54"(1372mm)	TCHP-5454-	■ ■ S	G ■ 7 ■	1486.05	1784.69	1513.35	1811.99	2319.51	2925.46	2541.94	3239.61
4		60"(1524mm)	60"(1524mm)	TCHP-6060-	■ ■ S	G ■ 7 ■	1590.60	1917.80	1625.88	1953.08	2651.64	3423.90	2934.00	3826.00

Jive Table — Bridge Base

Half Hexagon – Laminate or Wood

No. of Columns	Height	Depth	Width	Number	①	②	③	④	Laminate A		Laminate B		Wood Group A		Wood Group B	
									J	F	J	F	K	U	K	U
Base — No Power — No Cutout																
2	29"(737mm)	48"(1219mm)	48"(1219mm)	TCHX-4848-	■	■	SNG	4	\$1268.00	\$1538.08	\$1288.16	\$1558.24	\$1896.80	\$2357.70	\$2065.28	\$2593.54
2	42"(1067mm)	48"(1219mm)	48"(1219mm)	TCHX-4848-	■	■	SNG	7	1372.00	1642.08	1372.00	1642.08	2000.80	2461.70	2000.80	2461.70
Base — Power Ready — No Cutout																
2	29"(737mm)	48"(1219mm)	48"(1219mm)	TCHX-4848-	■	■	SNG	4	\$1288.00	\$1558.08	\$1308.16	\$1578.24	\$1916.80	\$2377.70	\$2085.28	\$2613.54
2	42"(1067mm)	48"(1219mm)	48"(1219mm)	TCHX-4848-	■	■	SNG	7	1392.00	1662.08	1392.00	1662.08	2020.80	2481.70	2020.80	2481.70



TCHX-SNG

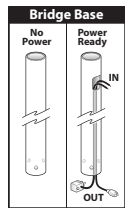

Features

- Includes 1 3/16"(30mm) thick standard top, base, adjustable glides or casters and hardware.
- Standard table heights are 29"(737mm) and 42"(1067mm).
- Laminate top with knife edge or 3mm edgeband edges or wood veneer top with 3mm wood edgeband or knife edge.
- Casters:
 - Four locking casters with 5/8"(16mm) adjustment.
 - Standard in black.
- Glides:
 - 5/8"(16mm) adjustment.
 - Standard in black.
- Casters and glides are not interchangeable.
- Ships unassembled.

Specification Tips

- Edge choice allows a flat seam between tables.
- **Not available with factory cutout option.**
- Power Ready Base:
 - Allows for cord management through one of the Bridge Base Base columns.
 - Powered leg location is determined during installation.**
 - Casters and Glides:
 - Specify the (J) option for Casters on the Power Ready base (only available with two column tables 29"(737mm) or 42"(1067mm) high)
 - Specify the (K) option for Glides on the Power Ready base
 - Flip Top Unit circuit breaker plug fits Power Ready Base opening.
- **Power cord length determines the distance to building power source.**
- Separately specified:
 - Ganging Mechanism - Recommended for use with power between tables.
 - Horizontal and Vertical Wire Management
 - Power and Data Components
 - Accessories
- Refer to Specification Guide:
 - Accessory placement and compatibility.
 - Seating capacities and leg locations.
 - Information on electrical components compatible with factory cut opening.
 - Power Ready base cable capacity.
- Application may require approval of local authority having jurisdiction (AHJ); ensure compliance before placing orders and installation.

To Order, Specify:

1) Product number, including:

① Surface Option:

- L Laminate
- W Wood

② Edge Option:

Laminate:

- J Edgeband
- F Knife

Wood:

- K Edgeband
- U Knife

③ Base and Wire Management Option:

Base - No Power:

- C Casters, add \$15.60 list
- G Glides

Base - Power Ready:

- J Casters, add \$15.60 list
- K Glides

④ Base Finish Option:

- A Painted
- B Polished, add \$46.80 list

- 2) Laminate surface color or wood finish color.
- 3) Edgeband trim color (laminated only).
- 4) Base trim color.

Note: \$41.60 upcharge list for Metallic trim colors.

Jive Table — C-Leg — Extruded

Rectangle – Laminate or Wood

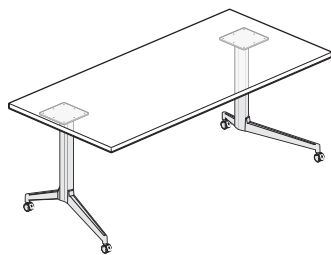

TCRA-SNC

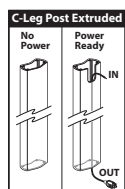
**Features**

- Includes 1 3/16" (30mm) thick standard top, base, adjustable glides or casters and hardware.
- Standard table heights are 29" (737mm) and 42" (1067mm).
- Laminate or wood top with 3mm edgeband on user edge and 1mm edgeband on remaining sides, or knife edge on user edge and 1mm edgeband on sides and back.
- Casters:
 - Two locking and two non-locking casters with 5/8" (16mm) adjustment.
 - Standard in black.
- Glides:
 - 5/8" (16mm) adjustment.
 - Standard in black.
- Casters and glides are not interchangeable.
- Ships unassembled.

Specification Tips

- Edge choice allows a flat seam between tables.
- **Specifying a cutout does not automatically include a Power Ready base.**
- Factory installed cutout is available for:
 - Specify the (A) option for a Center, Single-Sided/2 outlet Flip Top Unit
 - Specify the (F) option for a Center, Single-Sided/4 outlet Flip Top Unit
 - Specify the (J) option for a Center, Single-Sided/6 outlet Flip Top Unit
- Power Ready Base:
 - Allows for cord management through one of the Extruded C-Legs.
 - Powered leg location determined during installation.
 - Casters and Glides:
 - Specify the (J) option for Casters on the Power Ready base (only available on 29" (737mm) high tables)
 - Specify the (K) option for Glides on the Power Ready base (available on 29" (737mm) and 42" (1067mm) high tables)
 - Flip Top Unit circuit breaker plug fits Power Ready Base opening.
- **Power cord length determines the distance to building power source.**
- Separately specified:
 - Ganging Mechanism - Recommended for use with power between tables.
 - Horizontal and Vertical Wire Management
 - Power and Data Components
 - Accessories
- Refer to Specification Guide:
 - Accessory placement and compatibility.
 - Seating capacities and leg locations.
 - Information on electrical components compatible with factory cut opening.
 - Power Ready base cable capacity.
- Application may require approval of local authority having jurisdiction (AHJ); ensure compliance before placing orders and installation.

To Order, Specify:

1) Product number, including:

1 Surface Option:**L** Laminate**W** Wood**2 Edge Option:**

Laminate:

J Edgeband**F** Knife

Wood:

K Edgeband**U** Knife**3 Cutout:****N** No Cutout**A** Center, Single-Sided/2 outlets, add **\$33.13** list**F** Center, Single-Sided/4 outlets, add **\$33.13** list**J** Center, Single-Sided/6 outlets, add **\$33.13** list**4 Base and Wire Management Option:**

Base - No Power:

C Casters, add **\$15.60** list (29" Height Only)**G** Glides

Base - Power Ready:

J Casters, add **\$15.60** list (29" Height Only)**K** Glides**5 Base Finish Option:****A** Painted**B** Polished, add **\$46.80** list

2) Laminate surface color or wood finish color.

3) Edgeband trim color (laminated only).

4) Base trim color.

Note: **\$41.60** upcharge list for Metallic trim colors.

Jive Table — C-Leg — Extruded

Rectangle – Laminate or Wood

Height	Depth	Width	Number ① ② ③ ④ ⑤	Laminate A		Laminate B		Wood Group A		Wood Group B				
				J	F	J	F	K	U	K	U			
Base — No Power — No Cutout														
29"(737mm)	24"(610mm)	36"(914mm)	TCRA-2436-	S	C	4	\$ 681.04	\$ 844.88	\$ 752.56	\$ 916.40	\$1155.90	\$1355.69	\$1259.53	\$1483.97
		42"(1067mm)	TCRA-2442-	S	C	4	705.05	886.76	778.25	959.96	1231.90	1454.83	1349.45	1600.63
		48"(1219mm)	TCRA-2448-	S	C	4	729.23	929.85	804.11	1004.73	1308.44	1555.83	1440.01	1719.47
		54"(1372mm)	TCRA-2454-	S	C	4	753.58	974.13	830.14	1050.69	1385.49	1658.69	1531.20	1840.49
		60"(1524mm)	TCRA-2460-	S	C	4	778.10	1019.62	856.34	1097.86	1463.08	1763.40	1623.04	1963.68
		66"(1676mm)	TCRA-2466-	S	C	4	802.80	1066.31	882.72	1146.23	1541.19	1869.97	1715.52	2089.05
		72"(1829mm)	TCRA-2472-	S	C	4	827.66	1114.20	909.26	1195.80	1619.83	1978.40	1808.63	2216.60
		30"(762mm)	36"(914mm)	36"(914mm)	TCRA-3036-	S	C	4	\$ 714.60	\$ 890.66	\$ 788.64	\$ 964.70	\$1262.43	\$1478.03
42"(1067mm)	TCRA-3042-			S	C	4	743.94	938.39	820.08	1014.53	1355.40	1594.81	1495.27	1765.51
48"(1219mm)	TCRA-3048-			S	C	4	773.45	987.33	851.69	1065.57	1448.91	1713.45	1605.85	1905.14
54"(1372mm)	TCRA-3054-			S	C	4	803.14	1037.46	883.48	1117.80	1542.94	1833.95	1717.06	2046.94
60"(1524mm)	TCRA-3060-			S	C	4	833.00	1088.80	915.44	1171.24	1637.50	1956.30	1828.92	2190.92
66"(1676mm)	TCRA-3066-			S	C	4	863.03	1141.34	947.57	1225.88	1732.59	2080.51	1941.41	2337.08
72"(1829mm)	TCRA-3072-			S	C	4	893.24	1195.08	979.88	1281.72	1828.20	2206.58	2054.55	2485.41
42"(1067mm)	24"(610mm)			36"(914mm)	TCRA-2436-	S	CG7		\$ 880.62	\$1044.46	\$ 952.14	\$1115.98	\$1355.48	\$1555.27
		42"(1067mm)	TCRA-2442-	S	CG7		904.63	1086.34	977.83	1159.54	1431.48	1654.41	1549.03	1800.21
		48"(1219mm)	TCRA-2448-	S	CG7		928.81	1129.43	1003.69	1204.31	1508.02	1755.41	1639.59	1919.05
		54"(1372mm)	TCRA-2454-	S	CG7		953.16	1173.71	1029.72	1250.27	1585.07	1858.27	1730.78	2040.07
		60"(1524mm)	TCRA-2460-	S	CG7		977.68	1219.20	1055.92	1297.44	1662.66	1962.98	1822.62	2163.26
		66"(1676mm)	TCRA-2466-	S	CG7		1002.38	1265.89	1082.30	1345.81	1740.77	2069.55	1915.10	2288.63
		72"(1829mm)	TCRA-2472-	S	CG7		1027.24	1313.78	1108.84	1395.38	1819.41	2177.98	2008.21	2416.18
		30"(762mm)	36"(914mm)	36"(914mm)	TCRA-3036-	S	CG7		\$ 914.18	\$1090.24	\$ 988.22	\$1164.28	\$1462.01	\$1677.61
42"(1067mm)	TCRA-3042-			S	CG7		943.52	1137.97	1019.66	1214.11	1554.98	1794.39	1694.85	1965.09
48"(1219mm)	TCRA-3048-			S	CG7		973.03	1186.91	1051.27	1265.15	1648.49	1913.03	1805.43	2104.72
54"(1372mm)	TCRA-3054-			S	CG7		1002.72	1237.04	1083.06	1317.38	1742.52	2033.53	1916.64	2246.52
60"(1524mm)	TCRA-3060-			S	CG7		1032.58	1288.38	1115.02	1370.82	1837.08	2155.88	2028.50	2390.50
66"(1676mm)	TCRA-3066-			S	CG7		1062.61	1340.92	1147.15	1425.46	1932.17	2280.09	2140.99	2536.66
72"(1829mm)	TCRA-3072-			S	CG7		1092.82	1394.66	1179.46	1481.30	2027.78	2406.16	2254.13	2684.99

Jive Table — C-Leg — Extruded

Rectangle – Laminate or Wood

Height	Depth	Width	Number	① ② ③ ④ ⑤					Laminate A		Laminate B		Wood Group A		Wood Group B	
				J	F	J	F	K	U	K	U					
Base — Power Ready — No Cutout																
29"(737mm)	24"(610mm)	36"(914mm)	TCRA-2436-	S	C	4	\$ 701.04	\$ 864.88	\$ 772.56	\$ 936.40	\$1175.90	\$1375.69	\$1279.53	\$1503.97		
		42"(1067mm)	TCRA-2442-	S	C	4	725.05	906.76	798.25	979.96	1251.90	1474.83	1369.45	1620.63		
		48"(1219mm)	TCRA-2448-	S	C	4	749.23	949.85	824.11	1024.73	1328.44	1575.83	1460.01	1739.47		
		54"(1372mm)	TCRA-2454-	S	C	4	773.58	994.13	850.14	1070.69	1405.49	1678.69	1551.20	1860.49		
		60"(1524mm)	TCRA-2460-	S	C	4	798.10	1039.62	876.34	1117.86	1483.08	1783.40	1643.04	1983.68		
		66"(1676mm)	TCRA-2466-	S	C	4	822.80	1086.31	902.72	1166.23	1561.19	1889.97	1735.52	2109.05		
		72"(1829mm)	TCRA-2472-	S	C	4	847.66	1134.20	929.26	1215.80	1639.83	1998.40	1828.63	2236.60		
		30"(762mm)	36"(914mm)	TCRA-3036-	S	C	4	\$ 734.60	\$ 910.66	\$ 808.64	\$ 984.70	\$1282.43	\$1498.03	\$1405.33	\$1648.06	
42"(1067mm)	TCRA-3042-			S	C	4	763.94	958.39	840.08	1034.53	1375.40	1614.81	1515.27	1785.51		
48"(1219mm)	TCRA-3048-			S	C	4	793.45	1007.33	871.69	1085.57	1468.91	1733.45	1625.85	1925.14		
54"(1372mm)	TCRA-3054-			S	C	4	823.14	1057.46	903.48	1137.80	1562.94	1853.95	1737.06	2066.94		
60"(1524mm)	TCRA-3060-			S	C	4	853.00	1108.80	935.44	1191.24	1657.50	1976.30	1848.92	2210.92		
66"(1676mm)	TCRA-3066-			S	C	4	883.03	1161.34	967.57	1245.88	1752.59	2100.51	1961.41	2357.08		
72"(1829mm)	TCRA-3072-			S	C	4	913.24	1215.08	999.88	1301.72	1848.20	2226.58	2074.55	2505.41		
42"(1067mm)	24"(610mm)			36"(914mm)	TCRA-2436-	S	CK7	\$ 900.62	\$1064.46	\$ 972.14	\$1135.98	\$1375.48	\$1575.27	\$1479.11	\$1703.55	
		42"(1067mm)	TCRA-2442-	S	CK7	924.63	1106.34	997.83	1179.54	1451.48	1674.41	1569.03	1820.21			
		48"(1219mm)	TCRA-2448-	S	CK7	948.81	1149.43	1023.69	1224.31	1528.02	1775.41	1659.59	1939.05			
		54"(1372mm)	TCRA-2454-	S	CK7	973.16	1193.71	1049.72	1270.27	1605.07	1878.27	1750.78	2060.07			
		60"(1524mm)	TCRA-2460-	S	CK7	997.68	1239.20	1075.92	1317.44	1682.66	1982.98	1842.62	2183.26			
		66"(1676mm)	TCRA-2466-	S	CK7	1022.38	1285.89	1102.30	1365.81	1760.77	2089.55	1935.10	2308.63			
		72"(1829mm)	TCRA-2472-	S	CK7	1047.24	1333.78	1128.84	1415.38	1839.41	2197.98	2028.21	2436.18			
		30"(762mm)	36"(914mm)	TCRA-3036-	S	CK7	\$ 934.18	\$1110.24	\$1008.22	\$1184.28	\$1482.01	\$1697.61	\$1604.91	\$1847.64		
42"(1067mm)	TCRA-3042-			S	CK7	963.52	1157.97	1039.66	1234.11	1574.98	1814.39	1714.85	1985.09			
48"(1219mm)	TCRA-3048-			S	CK7	993.03	1206.91	1071.27	1285.15	1668.49	1933.03	1825.43	2124.72			
54"(1372mm)	TCRA-3054-			S	CK7	1022.72	1257.04	1103.06	1337.38	1762.52	2053.53	1936.64	2266.52			
60"(1524mm)	TCRA-3060-			S	CK7	1052.58	1308.38	1135.02	1390.82	1857.08	2175.88	2048.50	2410.50			
66"(1676mm)	TCRA-3066-			S	CK7	1082.61	1360.92	1167.15	1445.46	1952.17	2300.09	2160.99	2556.66			
72"(1829mm)	TCRA-3072-			S	CK7	1112.82	1414.66	1199.46	1501.30	2047.78	2426.16	2274.13	2704.99			

This page intentionally blank

Jive Table — C-Leg — Round

Rectangle – Laminate or Wood

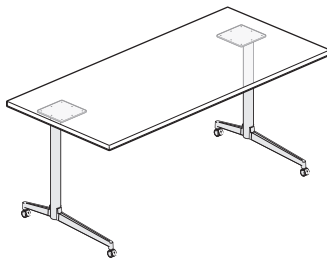

TCRA-SNB

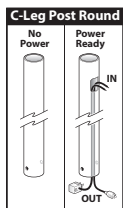
**Features**

- Includes 1 3/16" (30mm) thick standard top, base, adjustable glides or casters and hardware.
- Standard table heights are 29" (737mm) and 42" (1067mm).
- Laminate or wood top with 3mm edgeband on user edge and 1mm edgeband on remaining sides, or knife edge on user edge and 1mm edgeband on sides and back.
- Casters:
 - Two locking and two non-locking casters with 5/8" (16mm) adjustment.
 - Standard in black.
- Glides:
 - 5/8" (16mm) adjustment.
 - Standard in black.
- Casters and glides are not interchangeable.
- Ships unassembled.

Specification Tips

- Edge choice allows a flat seam between tables.
- **Specifying a cutout does not automatically include a Power Ready base.**
- Factory installed cutout is available for:
 - Specify the (A) option for a Center, Single-Sided/2 outlet Flip Top Unit
 - Specify the (F) option for a Center, Single-Sided/4 outlet Flip Top Unit
 - Specify the (J) option for a Center, Single-Sided/6 outlet Flip Top Unit
- Power Ready Base:
 - Allows for cord management through one of the Round C-Legs.
 - Powered leg location determined during installation.
 - Casters and Glides:
 - Specify the (J) option for Casters on the Power Ready base (only available on 29" (737mm) high tables)
 - Specify the (K) option for Glides on the Power Ready base (available on 29" (737mm) and 42" (1067mm) high tables)
 - Flip Top Unit circuit breaker plug fits Power Ready Base opening.
- **Power cord length determines the distance to building power source.**
- Separately specified:
 - Ganging Mechanism - Recommended for use with power between tables.
 - Horizontal and Vertical Wire Management
 - Power and Data Components
 - Accessories
- Refer to Specification Guide:
 - Accessory placement and compatibility.
 - Seating capacities and leg locations.
 - Information on electrical components compatible with factory cut opening.
 - Power Ready base cable capacity.
- Application may require approval of local authority having jurisdiction (AHJ); ensure compliance before placing orders and installation.

To Order, Specify:

1) Product number, including:

1 Surface Option:

- L** Laminate
- W** Wood

2 Edge Option:

Laminate:

- J** Edgeband
- F** Knife

Wood:

- K** Edgeband
- U** Knife

3 Cutout:

- N** No Cutout
- A** Center, Single-Sided/2 outlets, add **\$33.13** list
- F** Center, Single-Sided/4 outlets, add **\$33.13** list
- J** Center, Single-Sided/6 outlets, add **\$33.13** list

4 Base Foot and Wire Management:

Base - No Power:

- C** Casters, add **\$15.60** list (29" Height Only)
- G** Glides

Base - Power Ready:

- J** Casters, add **\$15.60** list (29" Height Only)
- K** Glides

5 Base Foot Finish Option:

- A** Painted
- B** Polished, add **\$46.80** list

2) Laminate surface color or wood finish color.

3) Edgeband trim color (laminated only).

4) Base trim color.

Note: **\$41.60** upcharge list for Metallic trim colors.

Jive Table — C-Leg — Round

Rectangle – Laminate or Wood

Height	Depth	Width	Number ① ② ③ ④ ⑤	Laminate A		Laminate B		Wood Group A		Wood Group B				
				J	F	J	F	K	U	K	U			
Base — No Power — No Cutout														
29"(737mm)	24"(610mm)	36"(914mm)	TCRA-2436-	S	B	4	\$533.78	\$ 697.62	\$ 605.30	\$ 769.14	\$1008.64	\$1208.43	\$1112.27	\$1336.71
		42"(1067mm)	TCRA-2442-	S	B	4	557.79	739.50	630.99	812.70	1084.64	1307.57	1202.19	1453.37
		48"(1219mm)	TCRA-2448-	S	B	4	581.97	782.59	656.85	857.47	1161.18	1408.57	1292.75	1572.21
		54"(1372mm)	TCRA-2454-	S	B	4	606.32	826.87	682.88	903.43	1238.23	1511.43	1383.94	1693.23
		60"(1524mm)	TCRA-2460-	S	B	4	630.84	872.36	709.08	950.60	1315.82	1616.14	1475.78	1816.42
		66"(1676mm)	TCRA-2466-	S	B	4	655.54	919.05	735.46	998.97	1393.93	1722.71	1568.26	1941.79
		72"(1829mm)	TCRA-2472-	S	B	4	680.40	966.94	762.00	1048.54	1472.57	1831.14	1661.37	2069.34
		30"(762mm)	36"(914mm)	TCRA-3036-	S	B	4	\$567.34	\$ 743.40	\$ 641.38	\$ 817.44	\$1115.17	\$1330.77	\$1238.07
42"(1067mm)	TCRA-3042-			S	B	4	596.68	791.13	672.82	867.27	1208.14	1447.55	1348.01	1618.25
48"(1219mm)	TCRA-3048-			S	B	4	626.19	840.07	704.43	918.31	1301.65	1566.19	1458.59	1757.88
54"(1372mm)	TCRA-3054-			S	B	4	655.88	890.20	736.22	970.54	1395.68	1686.69	1569.80	1899.68
60"(1524mm)	TCRA-3060-			S	B	4	685.74	941.54	768.18	1023.98	1490.24	1809.04	1681.66	2043.66
66"(1676mm)	TCRA-3066-			S	B	4	715.77	994.08	800.31	1078.62	1585.33	1933.25	1794.15	2189.82
72"(1829mm)	TCRA-3072-			S	B	4	745.98	1047.82	832.62	1134.46	1680.94	2059.32	1907.29	2338.15
42"(1067mm)	24"(610mm)			36"(914mm)	TCRA-2436-	S	BG7	\$733.36	\$ 897.20	\$ 804.88	\$ 968.72	\$1208.22	\$1408.01	\$1311.85
		42"(1067mm)	TCRA-2442-	S	BG7	757.37	939.08	830.57	1012.28	1284.22	1507.15	1401.77	1652.95	
		48"(1219mm)	TCRA-2448-	S	BG7	781.55	982.17	856.43	1057.05	1360.76	1608.15	1492.33	1771.79	
		54"(1372mm)	TCRA-2454-	S	BG7	805.90	1026.45	882.46	1103.01	1437.81	1711.01	1583.52	1892.81	
		60"(1524mm)	TCRA-2460-	S	BG7	830.42	1071.94	908.66	1150.18	1515.40	1815.72	1675.36	2016.00	
		66"(1676mm)	TCRA-2466-	S	BG7	855.12	1118.63	935.04	1198.55	1593.51	1922.29	1767.84	2141.37	
		72"(1829mm)	TCRA-2472-	S	BG7	879.98	1166.52	961.58	1248.12	1672.15	2030.72	1860.95	2268.92	
		30"(762mm)	36"(914mm)	TCRA-3036-	S	BG7	\$766.92	\$ 942.98	\$ 840.96	\$1017.02	\$1314.75	\$1530.35	\$1437.65	\$1680.38
42"(1067mm)	TCRA-3042-			S	BG7	796.26	990.71	872.40	1066.85	1407.72	1647.13	1547.59	1817.83	
48"(1219mm)	TCRA-3048-			S	BG7	825.77	1039.65	904.01	1117.89	1501.23	1765.77	1658.17	1957.46	
54"(1372mm)	TCRA-3054-			S	BG7	855.46	1089.78	935.80	1170.12	1595.26	1886.27	1769.38	2099.26	
60"(1524mm)	TCRA-3060-			S	BG7	885.32	1141.12	967.76	1223.56	1689.82	2008.62	1881.24	2243.24	
66"(1676mm)	TCRA-3066-			S	BG7	915.35	1193.66	999.89	1278.20	1784.91	2132.83	1993.73	2389.40	
72"(1829mm)	TCRA-3072-			S	BG7	945.56	1247.40	1032.20	1334.04	1880.52	2258.90	2106.87	2537.73	

Jive Table — C-Leg — Round

Rectangle – Laminate or Wood

Height	Depth	Width	Number	①	②	③	④	⑤	Laminate A		Laminate B		Wood Group A		Wood Group B	
									J	F	J	F	K	U	K	U
Base — Power Ready — No Cutout																
29"(737mm)	24"(610mm)	36"(914mm)	TCRA-2436-	■	■	S	B	4	\$553.78	\$ 717.62	\$ 625.30	\$ 789.14	\$1028.64	\$1228.43	\$1132.27	\$1356.71
		42"(1067mm)	TCRA-2442-	■	■	S	B	4	577.79	759.50	650.99	832.70	1104.64	1327.57	1222.19	1473.37
		48"(1219mm)	TCRA-2448-	■	■	S	B	4	601.97	802.59	676.85	877.47	1181.18	1428.57	1312.75	1592.21
		54"(1372mm)	TCRA-2454-	■	■	S	B	4	626.32	846.87	702.88	923.43	1258.23	1531.43	1403.94	1713.23
		60"(1524mm)	TCRA-2460-	■	■	S	B	4	650.84	892.36	729.08	970.60	1335.82	1636.14	1495.78	1836.42
		66"(1676mm)	TCRA-2466-	■	■	S	B	4	675.54	939.05	755.46	1018.97	1413.93	1742.71	1588.26	1961.79
		72"(1829mm)	TCRA-2472-	■	■	S	B	4	700.40	986.94	782.00	1068.54	1492.57	1851.14	1681.37	2089.34
	30"(762mm)	36"(914mm)	TCRA-3036-	■	■	S	B	4	\$587.34	\$ 763.40	\$ 661.38	\$ 837.44	\$1135.17	\$1350.77	\$1258.07	\$1500.80
		42"(1067mm)	TCRA-3042-	■	■	S	B	4	616.68	811.13	692.82	887.27	1228.14	1467.55	1368.01	1638.25
		48"(1219mm)	TCRA-3048-	■	■	S	B	4	646.19	860.07	724.43	938.31	1321.65	1586.19	1478.59	1777.88
		54"(1372mm)	TCRA-3054-	■	■	S	B	4	675.88	910.20	756.22	990.54	1415.68	1706.69	1589.80	1919.68
		60"(1524mm)	TCRA-3060-	■	■	S	B	4	705.74	961.54	788.18	1043.98	1510.24	1829.04	1701.66	2063.66
		66"(1676mm)	TCRA-3066-	■	■	S	B	4	735.77	1014.08	820.31	1098.62	1605.33	1953.25	1814.15	2209.82
		72"(1829mm)	TCRA-3072-	■	■	S	B	4	765.98	1067.82	852.62	1154.46	1700.94	2079.32	1927.29	2358.15
42"(1067mm)	24"(610mm)	36"(914mm)	TCRA-2436-	■	■	S	BK7	■	\$753.36	\$ 917.20	\$ 824.88	\$ 988.72	\$1228.22	\$1428.01	\$1331.85	\$1556.29
		42"(1067mm)	TCRA-2442-	■	■	S	BK7	■	777.37	959.08	850.57	1032.28	1304.22	1527.15	1421.77	1672.95
		48"(1219mm)	TCRA-2448-	■	■	S	BK7	■	801.55	1002.17	876.43	1077.05	1380.76	1628.15	1512.33	1791.79
		54"(1372mm)	TCRA-2454-	■	■	S	BK7	■	825.90	1046.45	902.46	1123.01	1457.81	1731.01	1603.52	1912.81
		60"(1524mm)	TCRA-2460-	■	■	S	BK7	■	850.42	1091.94	928.66	1170.18	1535.40	1835.72	1695.36	2036.00
		66"(1676mm)	TCRA-2466-	■	■	S	BK7	■	875.12	1138.63	955.04	1218.55	1613.51	1942.29	1787.84	2161.37
		72"(1829mm)	TCRA-2472-	■	■	S	BK7	■	899.98	1186.52	981.58	1268.12	1692.15	2050.72	1880.95	2288.92
	30"(762mm)	36"(914mm)	TCRA-3036-	■	■	S	BK7	■	\$786.92	\$ 962.98	\$ 860.96	\$1037.02	\$1334.75	\$1550.35	\$1457.65	\$1700.38
		42"(1067mm)	TCRA-3042-	■	■	S	BK7	■	816.26	1010.71	892.40	1086.85	1427.72	1667.13	1567.59	1837.83
		48"(1219mm)	TCRA-3048-	■	■	S	BK7	■	845.77	1059.65	924.01	1137.89	1521.23	1785.77	1678.17	1977.46
		54"(1372mm)	TCRA-3054-	■	■	S	BK7	■	875.46	1109.78	955.80	1190.12	1615.26	1906.27	1789.38	2119.26
		60"(1524mm)	TCRA-3060-	■	■	S	BK7	■	905.32	1161.12	987.76	1243.56	1709.82	2028.62	1901.24	2263.24
		66"(1676mm)	TCRA-3066-	■	■	S	BK7	■	935.35	1213.66	1019.89	1298.20	1804.91	2152.83	2013.73	2409.40
		72"(1829mm)	TCRA-3072-	■	■	S	BK7	■	965.56	1267.40	1052.20	1354.04	1900.52	2278.90	2126.87	2557.73

Jive Table — C-Leg (Round or Extruded) — Flip Base

Rectangle – Laminate or Wood

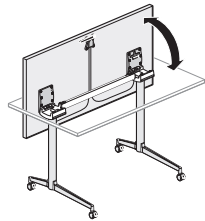

TCRA-SNH

Features

- Includes 1-3/16" (30mm) thick top, two C-Leg bases with round or extruded columns, stretcher and hardware
- Standard table height is 29" (737mm).
- Laminate or wood top with 3mm edgeband on user edge and 1mm edgeband on remaining sides, or knife edge on user edge and 1mm edgeband on sides and back.
- Casters:
 - Two locking and two non-locking casters with 5/8" (16mm) adjustment.
 - Standard in black.
- Glides:
 - 5/8" (16mm) adjustment.
 - Standard in black.
- Casters and glides are not interchangeable.
- Depth and width shown in nominal dimensions.
- Ships unassembled.

Specification Tips

- Edge choice allows a flat seam between tables.
- **Specifying a cutout does not automatically include a Power Ready base.**
- Factory installed cutout is available for:
 - Specify the (A) option for a Center, Single-Sided/2 outlet Flip Top Unit
 - Specify the (F) option for a Center, Single-Sided/4 outlet Flip Top Unit
 - Specify the (J) option for a Center, Single-Sided/6 outlet Flip Top Unit
- Power Ready Base:
 - Allows for cord management through one of the C-Leg (Round or Extruded) Base Legs. Powered leg location determined during installation.
 - Casters and Glides:
 - Specify the (L) option for Casters on the Power Ready base
 - Specify the (M) option for Glides on the Power Ready base
 - Flip Top Unit circuit breaker plug fits Power Ready Base opening.
- **Power cord length determines the distance to building power source.**
- Separately specified:
 - Ganging Mechanism - Recommended for use with power between tables.
 - Horizontal and Vertical Wire Management
 - Power and Data Components
 - Accessories
- Refer to Specification Guide:
 - Accessory placement and compatibility.
 - Seating capacities and leg locations.
 - Information on electrical components compatible with factory cut opening.
 - Power Ready base cable capacity.
- Application may require approval of local authority having jurisdiction (AHJ); ensure compliance before placing orders and installation.

To Order, Specify:

1) Product number, including:

1 Surface Option:

- L** Laminate
- W** Wood

2 Edge Option:

Laminate:

- J** Edgeband
- F** Knife

Wood:

- K** Edgeband
- U** Knife

3 Cutout:

- N** No Cutout
- A** Center, Single-Sided/2 outlets, add **\$33.13** list
- F** Center, Single-Sided/4 outlets, add **\$33.13** list
- J** Center, Single-Sided/6 outlets, add **\$33.13** list

4 Base and Wire Management Option:

Base - No Power:

- H** Casters, add **\$15.60** list
- F** Glides

Base - Power Ready:

- L** Casters, add **\$15.60** list
- M** Glides

5 Base Finish Option:

- A** Painted
- B** Polished, add **\$46.80** list

2) Surface color.

3) Edgeband trim color.

4) Base trim color.

Note: **\$41.60** upcharge list for Metallic trim colors.

Jive Table — C-Leg (Round or Extruded) — Flip Base

Rectangle – Laminate or Wood

Height	Depth	Width	Number	① ② ③ ④ ⑤					Laminate A		Laminate B		Wood Group A		Wood Group B	
				J	F	J	F	K	U	K	U					
Round — Base — No Power — No Cutout																
29"(737mm)	24"(610mm)	48"(1219mm)	TCRA-2448-	S	B	4	\$1039.21	\$1239.83	\$1114.09	\$1314.71	\$1618.42	\$1865.81	\$1749.99	\$2029.45		
		60"(1524mm)	TCRA-2460-	S	B	4	1088.08	1329.60	1166.32	1407.84	1773.06	2073.38	1933.02	2273.66		
		72"(1829mm)	TCRA-2472-	S	B	4	1137.64	1424.18	1219.24	1505.78	1929.81	2288.38	2118.61	2526.58		
30"(762mm)	48"(1219mm)	TCRA-3048-	S	B	4	\$1083.43	\$1297.31	\$1161.67	\$1375.55	\$1758.89	\$2023.43	\$1915.83	\$2215.12			
		60"(1524mm)	TCRA-3060-	S	B	4	1142.98	1398.78	1225.42	1481.22	1947.48	2266.28	2138.90	2500.90		
		72"(1829mm)	TCRA-3072-	S	B	4	1203.22	1505.06	1289.86	1591.70	2138.18	2516.56	2364.53	2795.39		
Extruded — Base — No Power — No Cutout																
29"(737mm)	24"(610mm)	48"(1219mm)	TCRA-2448-	S	C	4	\$1186.47	\$1387.09	\$1261.35	\$1461.97	\$1765.68	\$2013.07	\$1897.25	\$2176.71		
		60"(1524mm)	TCRA-2460-	S	C	4	1235.34	1476.86	1313.58	1555.10	1920.32	2220.64	2080.28	2420.92		
		72"(1829mm)	TCRA-2472-	S	C	4	1284.90	1571.44	1366.50	1653.04	2077.07	2435.64	2265.87	2673.84		
30"(762mm)	48"(1219mm)	TCRA-3048-	S	C	4	\$1230.69	\$1444.57	\$1308.93	\$1522.81	\$1906.15	\$2170.69	\$2063.09	\$2362.38			
		60"(1524mm)	TCRA-3060-	S	C	4	1290.24	1546.04	1372.68	1628.48	2094.74	2413.54	2286.16	2648.16		
		72"(1829mm)	TCRA-3072-	S	C	4	1350.48	1652.32	1437.12	1738.96	2285.44	2663.82	2511.79	2942.65		
Round — Base — Power Ready — No Cutout																
29"(737mm)	24"(610mm)	48"(1219mm)	TCRA-2448-	S	B	4	\$1059.21	\$1259.83	\$1134.09	\$1334.71	\$1638.42	\$1885.81	\$1769.99	\$2049.45		
		60"(1524mm)	TCRA-2460-	S	B	4	1108.08	1349.60	1186.32	1427.84	1793.06	2093.38	1953.02	2293.66		
		72"(1829mm)	TCRA-2472-	S	B	4	1157.64	1444.18	1239.24	1525.78	1949.81	2308.38	2138.61	2546.58		
30"(762mm)	48"(1219mm)	TCRA-3048-	S	B	4	\$1103.43	\$1317.31	\$1181.67	\$1395.55	\$1778.89	\$2043.43	\$1935.83	\$2235.12			
		60"(1524mm)	TCRA-3060-	S	B	4	1162.98	1418.78	1245.42	1501.22	1967.48	2286.28	2158.90	2520.90		
		72"(1829mm)	TCRA-3072-	S	B	4	1223.22	1525.06	1309.86	1611.70	2158.18	2536.56	2384.53	2815.39		
Extruded — Base — Power Ready — No Cutout																
29"(737mm)	24"(610mm)	48"(1219mm)	TCRA-2448-	S	C	4	\$1206.47	\$1407.09	\$1281.35	\$1481.97	\$1785.68	\$2033.07	\$1917.25	\$2196.71		
		60"(1524mm)	TCRA-2460-	S	C	4	1255.34	1496.86	1333.58	1575.10	1940.32	2240.64	2100.28	2440.92		
		72"(1829mm)	TCRA-2472-	S	C	4	1304.90	1591.44	1386.50	1673.04	2097.07	2455.64	2285.87	2693.84		
30"(762mm)	48"(1219mm)	TCRA-3048-	S	C	4	\$1250.69	\$1464.57	\$1328.93	\$1542.81	\$1926.15	\$2190.69	\$2083.09	\$2382.38			
		60"(1524mm)	TCRA-3060-	S	C	4	1310.24	1566.04	1392.68	1648.48	2114.74	2433.54	2306.16	2668.16		
		72"(1829mm)	TCRA-3072-	S	C	4	1370.48	1672.32	1457.12	1758.96	2305.44	2683.82	2531.79	2962.65		

Jive Table — Disc Base

Round – Laminate or Wood

Height	Depth	Width	Number ①②	Laminate A		Laminate B		Wood Group A		Wood Group B		
				J	F	J	F	K	U	K	U	
Base — No Power												
16"(406mm)	24"(610mm)	24"(610mm)	TCRN-2424-■ ■ SNDN1	\$668.38	\$ 824.22	\$668.38	\$ 824.22	\$ 707.74	\$ 793.76	\$ 720.22	\$ 811.49	
	30"(762mm)	30"(762mm)	TCRN-3030-■ ■ SNDN1	720.43	904.83	724.21	908.61	872.77	1021.70	915.28	1079.68	
	36"(914mm)	36"(914mm)	TCRN-3636-■ ■ SNDN1	782.98	995.94	791.38	1004.34	1071.22	1303.38	1149.74	1411.09	
	42"(1067mm)	42"(1067mm)	TCRN-4242-■ ■ SNDN1	856.03	1097.55	869.89	1111.41	1303.09	1639.53	1423.60	1806.58	
20"(508mm)	24"(610mm)	24"(610mm)	TCRN-2424-■ ■ SNDN2	\$673.63	\$ 829.47	\$673.63	\$ 829.47	\$ 712.99	\$ 799.01	\$ 725.47	\$ 816.74	
	30"(762mm)	30"(762mm)	TCRN-3030-■ ■ SNDN2	725.68	910.08	729.46	913.86	878.02	1026.95	920.53	1084.93	
	36"(914mm)	36"(914mm)	TCRN-3636-■ ■ SNDN2	788.23	1001.19	796.63	1009.59	1076.47	1308.63	1154.99	1416.34	
	42"(1067mm)	42"(1067mm)	TCRN-4242-■ ■ SNDN2	861.28	1102.80	875.14	1116.66	1308.34	1644.78	1428.85	1811.83	
29"(737mm)	24"(610mm)	24"(610mm)	TCRN-2424-■ ■ SNDN4	\$689.39	\$ 845.23	\$689.39	\$ 845.23	\$ 728.75	\$ 814.77	\$ 741.23	\$ 832.50	
	30"(762mm)	30"(762mm)	TCRN-3030-■ ■ SNDN4	741.44	925.84	745.22	929.62	893.78	1042.71	936.29	1100.69	
	36"(914mm)	36"(914mm)	TCRN-3636-■ ■ SNDN4	803.99	1016.95	812.39	1025.35	1092.23	1324.39	1170.75	1432.10	
	42"(1067mm)	42"(1067mm)	TCRN-4242-■ ■ SNDN4	877.04	1118.56	890.90	1132.42	1324.10	1660.54	1444.61	1827.59	
36"(914mm)	24"(610mm)	24"(610mm)	TCRN-2424-■ ■ SNDN6	\$694.80	\$ 850.64	\$694.80	\$ 850.64	\$ 734.16	\$ 820.18	\$ 746.64	\$ 837.91	
	30"(762mm)	30"(762mm)	TCRN-3030-■ ■ SNDN6	746.85	931.25	750.63	935.03	899.19	1048.12	941.70	1106.10	
	36"(914mm)	36"(914mm)	TCRN-3636-■ ■ SNDN6	809.40	1022.36	817.80	1030.76	1097.64	1329.80	1176.16	1437.51	
	42"(1067mm)	42"(1067mm)	TCRN-4242-■ ■ SNDN6	882.45	1123.97	896.31	1137.83	1329.51	1665.95	1450.02	1833.00	
Base — Power Ready												
16"(406mm)	24"(610mm)	24"(610mm)	TCRN-2424-■ ■ SNDK1	\$688.38	\$ 844.22	\$688.38	\$ 844.22	\$ 727.74	\$ 813.76	\$ 740.22	\$ 831.49	
	30"(762mm)	30"(762mm)	TCRN-3030-■ ■ SNDK1	740.43	924.83	744.21	928.61	892.77	1041.70	935.28	1099.68	
	36"(914mm)	36"(914mm)	TCRN-3636-■ ■ SNDK1	802.98	1015.94	811.38	1024.34	1091.22	1323.38	1169.74	1431.09	
	42"(1067mm)	42"(1067mm)	TCRN-4242-■ ■ SNDK1	876.03	1117.55	889.89	1131.41	1323.09	1659.53	1443.60	1826.58	
20"(508mm)	24"(610mm)	24"(610mm)	TCRN-2424-■ ■ SNDK2	\$693.63	\$ 849.47	\$693.63	\$ 849.47	\$ 732.99	\$ 819.01	\$ 745.47	\$ 836.74	
	30"(762mm)	30"(762mm)	TCRN-3030-■ ■ SNDK2	745.68	930.08	749.46	933.86	898.02	1046.95	940.53	1104.93	
	36"(914mm)	36"(914mm)	TCRN-3636-■ ■ SNDK2	808.23	1021.19	816.63	1029.59	1096.47	1328.63	1174.99	1436.34	
	42"(1067mm)	42"(1067mm)	TCRN-4242-■ ■ SNDK2	881.28	1122.80	895.14	1136.66	1328.34	1664.78	1448.85	1831.83	
29"(737mm)	24"(610mm)	24"(610mm)	TCRN-2424-■ ■ SNDK4	\$709.39	\$ 865.23	\$709.39	\$ 865.23	\$ 748.75	\$ 834.77	\$ 761.23	\$ 852.50	
	30"(762mm)	30"(762mm)	TCRN-3030-■ ■ SNDK4	761.44	945.84	765.22	949.62	913.78	1062.71	956.29	1120.69	
	36"(914mm)	36"(914mm)	TCRN-3636-■ ■ SNDK4	823.99	1036.95	832.39	1045.35	1112.23	1344.39	1190.75	1452.10	
	42"(1067mm)	42"(1067mm)	TCRN-4242-■ ■ SNDK4	897.04	1138.56	910.90	1152.42	1344.10	1680.54	1464.61	1847.59	
36"(914mm)	24"(610mm)	24"(610mm)	TCRN-2424-■ ■ SNDK6	\$714.80	\$ 870.64	\$714.80	\$ 870.64	\$ 754.16	\$ 840.18	\$ 766.64	\$ 857.91	
	30"(762mm)	30"(762mm)	TCRN-3030-■ ■ SNDK6	766.85	951.25	770.63	955.03	919.19	1068.12	961.70	1126.10	
	36"(914mm)	36"(914mm)	TCRN-3636-■ ■ SNDK6	829.40	1042.36	837.80	1050.76	1117.64	1349.80	1196.16	1457.51	
	42"(1067mm)	42"(1067mm)	TCRN-4242-■ ■ SNDK6	902.45	1143.97	916.31	1157.83	1349.51	1685.95	1470.02	1853.00	

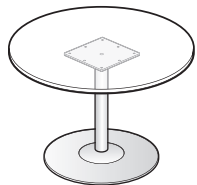

TCRN-SND

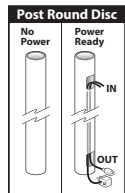

Features

- Includes 1 3/16"(30mm) thick standard top, base and hardware.
- Standard table heights are 16"(406mm), 20"(508mm), 29"(737mm) and 36"(914mm).
- Table is available with black glides only.
- Ships unassembled.

Specification Tips

- Disc Base Diameter Sizes:
 - 24"(610mm) and 30"(762mm) tops include 21"(533mm) disc base
 - 36"(914mm) tops include 27"(686mm) disc base
- Power Ready Base:
 - Allows for cord management through the Disk Base (available on 16"(406mm), 20"(508mm), 29"(737mm) and 36"(914mm) high tables)
 - Edge mounted power is recommended.
- **Power cord length determines the distance to building power source.**
- Separately specified:
 - Horizontal and Vertical Wire Management
 - Power and Data Components
 - Accessories
- Refer to Specification Guide:
 - Accessory placement and compatibility.
 - Power Ready base cable capacity.
- Application may require approval of local authority having jurisdiction (AHJ); ensure compliance before placing orders and installation.

To Order, Specify:

- 1) Product number, including:

① Surface Option:

- L** Laminate
- W** Wood

② Edge Option:

Laminate:

- J** Edgeband
- F** Knife

Wood:

- K** Edgeband
- U** Knife

- 2) Laminate surface color or wood finish color.
- 3) Edgeband trim color (laminated only).
- 4) Base trim color.

Note: \$41.60 upcharge list for Metallic trim colors.

Jive Table — Disc Base

Square – Laminate or Wood

Height	Depth	Width	Number ①②	Laminate A		Laminate B		Wood Group A		Wood Group B		
				J	F	J	F	K	U	K	U	
Base — No Power												
16"(406mm)	24"(610mm)	24"(610mm)	TCRQ-2424-■ ■ SNDN1	\$668.38	\$ 824.22	\$668.38	\$ 824.22	\$ 707.74	\$ 793.76	\$ 720.22	\$ 811.49	
	30"(762mm)	30"(762mm)	TCRQ-3030-■ ■ SNDN1	720.43	904.83	724.21	908.61	872.77	1021.70	915.28	1079.68	
	36"(914mm)	36"(914mm)	TCRQ-3636-■ ■ SNDN1	782.98	995.94	791.38	1004.34	1071.22	1303.38	1149.74	1411.09	
	42"(1067mm)	42"(1067mm)	TCRQ-4242-■ ■ SNDN1	856.03	1097.55	869.89	1111.41	1303.09	1639.53	1423.60	1806.58	
20"(508mm)	24"(610mm)	24"(610mm)	TCRQ-2424-■ ■ SNDN2	\$673.63	\$ 829.47	\$673.63	\$ 829.47	\$ 712.99	\$ 799.01	\$ 725.47	\$ 816.74	
	30"(762mm)	30"(762mm)	TCRQ-3030-■ ■ SNDN2	725.68	910.08	729.46	913.86	878.02	1026.95	920.53	1084.93	
	36"(914mm)	36"(914mm)	TCRQ-3636-■ ■ SNDN2	788.23	1001.19	796.63	1009.59	1076.47	1308.63	1154.99	1416.34	
	42"(1067mm)	42"(1067mm)	TCRQ-4242-■ ■ SNDN2	861.28	1102.80	875.14	1116.66	1308.34	1644.78	1428.85	1811.83	
29"(737mm)	24"(610mm)	24"(610mm)	TCRQ-2424-■ ■ SNDN4	\$689.39	\$ 845.23	\$689.39	\$ 845.23	\$ 728.75	\$ 814.77	\$ 741.23	\$ 832.50	
	30"(762mm)	30"(762mm)	TCRQ-3030-■ ■ SNDN4	741.44	925.84	745.22	929.62	893.78	1042.71	936.29	1100.69	
	36"(914mm)	36"(914mm)	TCRQ-3636-■ ■ SNDN4	803.99	1016.95	812.39	1025.35	1092.23	1324.39	1170.75	1432.10	
	42"(1067mm)	42"(1067mm)	TCRQ-4242-■ ■ SNDN4	877.04	1118.56	890.90	1132.42	1324.10	1660.54	1444.61	1827.59	
36"(914mm)	24"(610mm)	24"(610mm)	TCRQ-2424-■ ■ SNDN6	\$694.80	\$ 850.64	\$694.80	\$ 850.64	\$ 734.16	\$ 820.18	\$ 746.64	\$ 837.91	
	30"(762mm)	30"(762mm)	TCRQ-3030-■ ■ SNDN6	746.85	931.25	750.63	935.03	899.19	1048.12	941.70	1106.10	
	36"(914mm)	36"(914mm)	TCRQ-3636-■ ■ SNDN6	809.40	1022.36	817.80	1030.76	1097.64	1329.80	1176.16	1437.51	
Base — Power Ready												
16"(406mm)	24"(610mm)	24"(610mm)	TCRQ-2424-■ ■ SNDK1	\$688.38	\$ 844.22	\$688.38	\$ 844.22	\$ 727.74	\$ 813.76	\$ 740.22	\$ 831.49	
	30"(762mm)	30"(762mm)	TCRQ-3030-■ ■ SNDK1	740.43	924.83	744.21	928.61	892.77	1041.70	935.28	1099.68	
	36"(914mm)	36"(914mm)	TCRQ-3636-■ ■ SNDK1	802.98	1015.94	811.38	1024.34	1091.22	1323.38	1169.74	1431.09	
	42"(1067mm)	42"(1067mm)	TCRQ-4242-■ ■ SNDK1	876.03	1117.55	889.89	1131.41	1323.09	1659.53	1443.60	1826.58	
20"(508mm)	24"(610mm)	24"(610mm)	TCRQ-2424-■ ■ SNDK2	\$693.63	\$ 849.47	\$693.63	\$ 849.47	\$ 732.99	\$ 819.01	\$ 745.47	\$ 836.74	
	30"(762mm)	30"(762mm)	TCRQ-3030-■ ■ SNDK2	745.68	930.08	749.46	933.86	898.02	1046.95	940.53	1104.93	
	36"(914mm)	36"(914mm)	TCRQ-3636-■ ■ SNDK2	808.23	1021.19	816.63	1029.59	1096.47	1328.63	1174.99	1436.34	
	42"(1067mm)	42"(1067mm)	TCRQ-4242-■ ■ SNDK2	881.28	1122.80	895.14	1136.66	1328.34	1664.78	1448.85	1831.83	
29"(737mm)	24"(610mm)	24"(610mm)	TCRQ-2424-■ ■ SNDK4	\$709.39	\$ 865.23	\$709.39	\$ 865.23	\$ 748.75	\$ 834.77	\$ 761.23	\$ 852.50	
	30"(762mm)	30"(762mm)	TCRQ-3030-■ ■ SNDK4	761.44	945.84	765.22	949.62	913.78	1062.71	956.29	1120.69	
	36"(914mm)	36"(914mm)	TCRQ-3636-■ ■ SNDK4	823.99	1036.95	832.39	1045.35	1112.23	1344.39	1190.75	1452.10	
	42"(1067mm)	42"(1067mm)	TCRQ-4242-■ ■ SNDK4	897.04	1138.56	910.90	1152.42	1344.10	1680.54	1464.61	1847.59	
36"(914mm)	24"(610mm)	24"(610mm)	TCRQ-2424-■ ■ SNDK6	\$714.80	\$ 870.64	\$714.80	\$ 870.64	\$ 754.16	\$ 840.18	\$ 766.64	\$ 857.91	
	30"(762mm)	30"(762mm)	TCRQ-3030-■ ■ SNDK6	766.85	951.25	770.63	955.03	919.19	1068.12	961.70	1126.10	
	36"(914mm)	36"(914mm)	TCRQ-3636-■ ■ SNDK6	829.40	1042.36	837.80	1050.76	1117.64	1349.80	1196.16	1457.51	

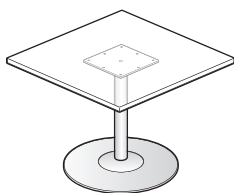

TCRQ-SND

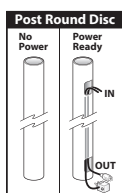
**Features**

- Includes 1 3/16"(30mm) thick standard top, base and hardware.
- Standard table heights are 16"(406mm), 20"(508mm), 29"(737mm) and 36"(914mm).
- Table is available with black glides only.
- Ships unassembled.

Specification Tips

- Edge choice allows a flat seam between tables.
- Disc Base Diameter Sizes:
 - 24"(610mm) and 30"(762mm) tops include 21"(533mm) disc base
 - 36"(914mm) tops include 27"(686mm) disc base
- Power Ready Base:
 - Allows for cord management through the Disk Base (available on 16"(406mm), 20"(508mm), 29"(737mm) and 36"(914mm) high tables)
 - Edge mounted power is recommended.
- **Power cord length determines the distance to building power source.**
- Separately specified:
 - Horizontal and Vertical Wire Management
 - Power and Data Components
 - Accessories
- Refer to Specification Guide:
 - Accessory placement and compatibility.
 - Power Ready base cable capacity.
- Application may require approval of local authority having jurisdiction (AHJ); ensure compliance before placing orders and installation.

To Order, Specify:

- 1) Product number, including:

① Surface Option:

- L Laminate
- W Wood

② Edge Option:

Laminate:

- J Edgeband
- F Knife

Wood:

- K Edgeband
- U Knife

- 2) Laminate surface color or wood finish color.
- 3) Edgeband trim color (laminated only).
- 4) Base trim color.

Note: \$41.60 upcharge list for Metallic trim colors.

Jive Table — Disc Base

Pebble – Laminate or Wood

Height	Depth	Width	Number ①②	Laminate A		Laminate B		Wood Group A		Wood Group B	
				J	F	J	F	K	U	K	U
Base — No Power											
16"(406mm)	24"(610mm)	24"(610mm)	TCRP-2424-■ ■ SNDN1	\$668.38	\$ 824.22	\$668.38	\$ 824.22	\$ 707.74	\$ 793.76	\$ 720.22	\$ 811.49
	30"(762mm)	30"(762mm)	TCRP-3030-■ ■ SNDN1	720.43	904.83	724.21	908.61	872.77	1021.70	915.28	1079.68
	36"(914mm)	36"(914mm)	TCRP-3636-■ ■ SNDN1	782.98	995.94	791.38	1004.34	1071.22	1303.38	1149.74	1411.09
	42"(1067mm)	42"(1067mm)	TCRP-4242-■ ■ SNDN1	856.03	1097.55	869.89	1111.41	1303.09	1639.53	1423.60	1806.58
20"(508mm)	24"(610mm)	24"(610mm)	TCRP-2424-■ ■ SNDN2	\$673.63	\$ 829.47	\$673.63	\$ 829.47	\$ 712.99	\$ 799.01	\$ 725.47	\$ 816.74
	30"(762mm)	30"(762mm)	TCRP-3030-■ ■ SNDN2	725.68	910.08	729.46	913.86	878.02	1026.95	920.53	1084.93
	36"(914mm)	36"(914mm)	TCRP-3636-■ ■ SNDN2	788.23	1001.19	796.63	1009.59	1076.47	1308.63	1154.99	1416.34
	42"(1067mm)	42"(1067mm)	TCRP-4242-■ ■ SNDN2	861.28	1102.80	875.14	1116.66	1308.34	1644.78	1428.85	1811.83
29"(737mm)	24"(610mm)	24"(610mm)	TCRP-2424-■ ■ SNDN4	\$689.39	\$ 845.23	\$689.39	\$ 845.23	\$ 728.75	\$ 814.77	\$ 741.23	\$ 832.50
	30"(762mm)	30"(762mm)	TCRP-3030-■ ■ SNDN4	741.44	925.84	745.22	929.62	893.78	1042.71	936.29	1100.69
	36"(914mm)	36"(914mm)	TCRP-3636-■ ■ SNDN4	803.99	1016.95	812.39	1025.35	1092.23	1324.39	1170.75	1432.10
	42"(1067mm)	42"(1067mm)	TCRP-4242-■ ■ SNDN4	877.04	1118.56	890.90	1132.42	1324.10	1660.54	1444.61	1827.59
36"(914mm)	24"(610mm)	24"(610mm)	TCRP-2424-■ ■ SNDN6	\$694.80	\$ 850.64	\$694.80	\$ 850.64	\$ 734.16	\$ 820.18	\$ 746.64	\$ 837.91
	30"(762mm)	30"(762mm)	TCRP-3030-■ ■ SNDN6	746.85	931.25	750.63	935.03	899.19	1048.12	941.70	1106.10
	36"(914mm)	36"(914mm)	TCRP-3636-■ ■ SNDN6	809.40	1022.36	817.80	1030.76	1097.64	1329.80	1176.16	1437.51
	42"(1067mm)	42"(1067mm)	TCRP-4242-■ ■ SNDN6	882.45	1123.97	896.31	1137.83	1329.51	1665.95	1450.02	1833.00
Base — Power Ready											
16"(406mm)	24"(610mm)	24"(610mm)	TCRP-2424-■ ■ SNDK1	\$688.38	\$ 844.22	\$688.38	\$ 844.22	\$ 727.74	\$ 813.76	\$ 740.22	\$ 831.49
	30"(762mm)	30"(762mm)	TCRP-3030-■ ■ SNDK1	740.43	924.83	744.21	928.61	892.77	1041.70	935.28	1099.68
	36"(914mm)	36"(914mm)	TCRP-3636-■ ■ SNDK1	802.98	1015.94	811.38	1024.34	1091.22	1323.38	1169.74	1431.09
	42"(1067mm)	42"(1067mm)	TCRP-4242-■ ■ SNDK1	876.03	1117.55	889.89	1131.41	1323.09	1659.53	1443.60	1826.58
20"(508mm)	24"(610mm)	24"(610mm)	TCRP-2424-■ ■ SNDK2	\$693.63	\$ 849.47	\$693.63	\$ 849.47	\$ 732.99	\$ 819.01	\$ 745.47	\$ 836.74
	30"(762mm)	30"(762mm)	TCRP-3030-■ ■ SNDK2	745.68	930.08	749.46	933.86	898.02	1046.95	940.53	1104.93
	36"(914mm)	36"(914mm)	TCRP-3636-■ ■ SNDK2	808.23	1021.19	816.63	1029.59	1096.47	1328.63	1174.99	1436.34
	42"(1067mm)	42"(1067mm)	TCRP-4242-■ ■ SNDK2	881.28	1122.80	895.14	1136.66	1328.34	1664.78	1448.85	1831.83
29"(737mm)	24"(610mm)	24"(610mm)	TCRP-2424-■ ■ SNDK4	\$709.39	\$ 865.23	\$709.39	\$ 865.23	\$ 748.75	\$ 834.77	\$ 761.23	\$ 852.50
	30"(762mm)	30"(762mm)	TCRP-3030-■ ■ SNDK4	761.44	945.84	765.22	949.62	913.78	1062.71	956.29	1120.69
	36"(914mm)	36"(914mm)	TCRP-3636-■ ■ SNDK4	823.99	1036.95	832.39	1045.35	1112.23	1344.39	1190.75	1452.10
	42"(1067mm)	42"(1067mm)	TCRP-4242-■ ■ SNDK4	897.04	1138.56	910.90	1152.42	1344.10	1680.54	1464.61	1847.59
36"(914mm)	24"(610mm)	24"(610mm)	TCRP-2424-■ ■ SNDK6	\$714.80	\$ 870.64	\$714.80	\$ 870.64	\$ 754.16	\$ 840.18	\$ 766.64	\$ 857.91
	30"(762mm)	30"(762mm)	TCRP-3030-■ ■ SNDK6	766.85	951.25	770.63	955.03	919.19	1068.12	961.70	1126.10
	36"(914mm)	36"(914mm)	TCRP-3636-■ ■ SNDK6	829.40	1042.36	837.80	1050.76	1117.64	1349.80	1196.16	1457.51
	42"(1067mm)	42"(1067mm)	TCRP-4242-■ ■ SNDK6	902.45	1143.97	916.31	1157.83	1349.51	1685.95	1470.02	1853.00

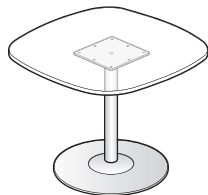

TCRP-SND

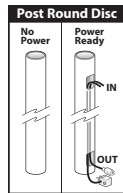

Features

- Includes 1 3/16"(30mm) thick standard top, base and hardware.
- Laminate top with knife edge or 3mm edgeband edges or wood veneer top with 3mm wood edgeband or knife edge.
- Standard table heights are 16"(406mm), 20"(508mm), 29"(737mm) and 36"(914mm).
- Table is available with black glides only.
- Ships unassembled.

Specification Tips

- Disc Base Diameter Sizes:
 - 24"(610mm) and 30"(762mm) tops include 21"(533mm) disc base
 - 36"(914mm) tops include 27"(686mm) disc base
- Power Ready Base:
 - Allows for cord management through the Disk Base (available on 16"(406mm), 20"(508mm), 29"(737mm) and 36"(914mm) high tables)
 - Edge mounted power is recommended.
- **Power cord length determines the distance to building power source.**
- Separately specified:
 - Horizontal and Vertical Wire Management
 - Power and Data Components
 - Accessories
- Refer to Specification Guide:
 - Accessory placement and compatibility.
 - Power Ready base cable capacity.
- Application may require approval of local authority having jurisdiction (AHJ); ensure compliance before placing orders and installation.

To Order, Specify:

- 1) Product number, including:

① Surface Option:

- L Laminate
- W Wood

② Edge Option:

Laminate:

- J Edgeband
- F Knife

Wood:

- K Edgeband
- U Knife

- 2) Laminate surface color or wood finish color.
- 3) Edgeband trim color (laminated only).
- 4) Base trim color.

Note: \$41.60 upcharge list for Metallic trim colors.

Jive Table — Disc Base

Rectangle – Laminate or Wood

Height	Depth	Width	Number ①②	Laminate A		Laminate B		Wood Group A		Wood Group B		
				J	F	J	F	K	U	K	U	
Base — No Power												
16"(406mm)	24"(610mm)	30"(762mm)	TCRA-2430-■ ■ SNDN1	\$680.07	\$827.06	\$749.91	\$ 896.90	\$1103.28	\$1281.26	\$1193.11	\$1392.35	
	30"(762mm)	36"(914mm)	TCRA-3036-■ ■ SNDN1	737.46	913.52	811.50	987.56	1285.29	1500.89	1408.19	1650.92	
20"(508mm)	24"(610mm)	30"(762mm)	TCRA-2430-■ ■ SNDN2	\$685.32	\$832.31	\$755.16	\$ 902.15	\$1108.53	\$1286.51	\$1198.36	\$1397.60	
	30"(762mm)	36"(914mm)	TCRA-3036-■ ■ SNDN2	742.71	918.77	816.75	992.81	1290.54	1506.14	1413.44	1656.17	
29"(737mm)	24"(610mm)	30"(762mm)	TCRA-2430-■ ■ SNDN4	\$701.08	\$848.07	\$770.92	\$ 917.91	\$1124.29	\$1302.27	\$1214.12	\$1413.36	
	30"(762mm)	36"(914mm)	TCRA-3036-■ ■ SNDN4	758.47	934.53	832.51	1008.57	1306.30	1521.90	1429.20	1671.93	
36"(914mm)	24"(610mm)	30"(762mm)	TCRA-2430-■ ■ SNDN6	\$706.49	\$853.48	\$776.33	\$ 923.32	\$1129.70	\$1307.68	\$1219.53	\$1418.77	
	30"(762mm)	36"(914mm)	TCRA-3036-■ ■ SNDN6	763.88	939.94	837.92	1013.98	1311.71	1527.31	1434.61	1677.34	
Base — Power Ready												
16"(406mm)	24"(610mm)	30"(762mm)	TCRA-2430-■ ■ SNDK1	\$700.07	\$847.06	\$769.91	\$ 916.90	\$1123.28	\$1301.26	\$1213.11	\$1412.35	
	30"(762mm)	36"(914mm)	TCRA-3036-■ ■ SNDK1	757.46	933.52	831.50	1007.56	1305.29	1520.89	1428.19	1670.92	
20"(508mm)	24"(610mm)	30"(762mm)	TCRA-2430-■ ■ SNDK2	\$705.32	\$852.31	\$775.16	\$ 922.15	\$1128.53	\$1306.51	\$1218.36	\$1417.60	
	30"(762mm)	36"(914mm)	TCRA-3036-■ ■ SNDK2	762.71	938.77	836.75	1012.81	1310.54	1526.14	1433.44	1676.17	
29"(737mm)	24"(610mm)	30"(762mm)	TCRA-2430-■ ■ SNDK4	\$721.08	\$868.07	\$790.92	\$ 937.91	\$1144.29	\$1322.27	\$1234.12	\$1433.36	
	30"(762mm)	36"(914mm)	TCRA-3036-■ ■ SNDK4	778.47	954.53	852.51	1028.57	1326.30	1541.90	1449.20	1691.93	
36"(914mm)	24"(610mm)	30"(762mm)	TCRA-2430-■ ■ SNDK6	\$726.49	\$873.48	\$796.33	\$ 943.32	\$1149.70	\$1327.68	\$1239.53	\$1438.77	
	30"(762mm)	36"(914mm)	TCRA-3036-■ ■ SNDK6	783.88	959.94	857.92	1033.98	1331.71	1547.31	1454.61	1697.34	

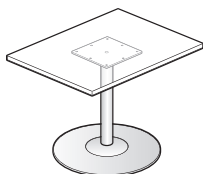

TCRA-SND

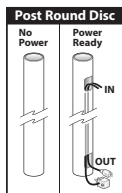

Features

- Includes 1 3/16"(30mm) thick standard top, two bases and hardware.
- Laminate top with knife edge or 3mm edgeband edges or wood veneer top with 3mm wood edgeband or knife edge.
- Standard table heights are 16"(406mm), 20"(508mm), 29"(737mm) and 36"(914mm).
- Table is available with black glides only.
- Ships unassembled.

Specification Tips

- Edge choice allows a flat seam between tables.
- Disc Base Diameter Sizes:
 - 24"(610mm) and 30"(762mm) tops include 21"(533mm) disc base
- Power Ready Base:
 - Allows for cord management through the Disk Base (available on 16"(406mm), 20"(508mm), 29"(737mm) and 36"(914mm) high tables)
 - Edge mounted power is recommended.
- **Power cord length determines the distance to building power source.**
- Separately specified:
 - Horizontal and Vertical Wire Management
 - Power and Data Components
 - Accessories
- Refer to Specification Guide:
 - Accessory placement and compatibility.
 - Power Ready base cable capacity.
- Application may require approval of local authority having jurisdiction (AHJ); ensure compliance before placing orders and installation.

To Order, Specify:

- 1) Product number, including:

① Surface Option:

- L Laminate
- W Wood

② Edge Option:

Laminate:

- J Edgeband
- F Knife

Wood:

- K Edgeband
- U Knife

- 2) Laminate surface color or wood finish color.
- 3) Edgeband trim color (laminate only).
- 4) Base trim color.

Note: \$41.60 upcharge list for Metallic trim colors.

Jive Table — Dual Disc Base

Pebble – Laminate or Wood

Height	Depth	Width	Number ① ② ③	Laminate A		Laminate B		Wood Group A		Wood Group B			
				J	F	J	F	K	U	K	U		
Base — No Power													
29"(737mm)	30"(762mm)	60"(1524mm)	TCRP-3060-	S	DN4	\$1435.64	\$1691.44	\$1518.08	\$1773.88	\$2240.14	\$2558.94	\$2431.56	\$2793.56
		72"(1829mm)	TCRP-3072-	S	DN4	1495.88	1797.72	1582.52	1884.36	2430.84	2809.22	2657.19	3088.05
36"(914mm)	72"(1829mm)	TCRP-3672-	S	DN4	\$1561.45	\$1878.60	\$1653.13	\$1970.28	\$2639.21	\$3037.40	\$2903.11	\$3356.87	
		84"(2134mm)	TCRP-3684-	S	DN4	1633.05	2001.38	1729.77	2098.10	2865.96	3330.38	3171.33	3701.65
42"(1067mm)	84"(2134mm)	TCRP-4284-	S	DN4	\$1709.30	\$2093.96	\$1811.90	\$2196.56	\$3108.28	\$3593.84	\$3457.29	\$4012.05	
		96"(2438mm)	TCRP-4296-	S	DN4	1792.26	2233.25	1900.74	2341.73	3371.09	3929.53	3768.12	4407.11
36"(914mm)	30"(762mm)	60"(1524mm)	TCRP-3060-	S	DN6	\$1446.46	\$1702.26	\$1528.90	\$1784.70	\$2250.96	\$2569.76	\$2442.38	\$2804.38
		72"(1829mm)	TCRP-3072-	S	DN6	1506.70	1808.54	1593.34	1895.18	2441.66	2820.04	2668.01	3098.87
36"(914mm)	72"(1829mm)	TCRP-3672-	S	DN6	\$1572.27	\$1889.42	\$1663.95	\$1981.10	\$2650.03	\$3048.22	\$2913.93	\$3367.69	
		84"(2134mm)	TCRP-3684-	S	DN6	1643.87	2012.20	1740.59	2108.92	2876.78	3341.20	3182.15	3712.47
42"(1067mm)	84"(2134mm)	TCRP-4284-	S	DN6	\$1720.12	\$2104.78	\$1822.72	\$2207.38	\$3119.10	\$3604.66	\$3468.11	\$4022.87	
		96"(2438mm)	TCRP-4296-	S	DN6	1803.08	2244.07	1911.56	2352.55	3381.91	3940.35	3778.94	4417.93
Base — Power Ready													
29"(737mm)	30"(762mm)	60"(1524mm)	TCRP-3060-	S	DK4	\$1455.64	\$1711.44	\$1538.08	\$1793.88	\$2260.14	\$2578.94	\$2451.56	\$2813.56
		72"(1829mm)	TCRP-3072-	S	DK4	1515.88	1817.72	1602.52	1904.36	2450.84	2829.22	2677.19	3108.05
36"(914mm)	72"(1829mm)	TCRP-3672-	S	DK4	\$1581.45	\$1898.60	\$1673.13	\$1990.28	\$2659.21	\$3057.40	\$2923.11	\$3376.87	
		84"(2134mm)	TCRP-3684-	S	DK4	1653.05	2021.38	1749.77	2118.10	2885.96	3350.38	3191.33	3721.65
42"(1067mm)	84"(2134mm)	TCRP-4284-	S	DK4	\$1729.30	\$2113.96	\$1831.90	\$2216.56	\$3128.28	\$3613.84	\$3477.29	\$4032.05	
		96"(2438mm)	TCRP-4296-	S	DK4	1812.26	2253.25	1920.74	2361.73	3391.09	3949.53	3788.12	4427.11
36"(914mm)	30"(762mm)	60"(1524mm)	TCRP-3060-	S	DK6	\$1466.46	\$1722.26	\$1548.90	\$1804.70	\$2270.96	\$2589.76	\$2462.38	\$2824.38
		72"(1829mm)	TCRP-3072-	S	DK6	1526.70	1828.54	1613.34	1915.18	2461.66	2840.04	2688.01	3118.87
36"(914mm)	72"(1829mm)	TCRP-3672-	S	DK6	\$1592.27	\$1909.42	\$1683.95	\$2001.10	\$2670.03	\$3068.22	\$2933.93	\$3387.69	
		84"(2134mm)	TCRP-3684-	S	DK6	1663.87	2032.20	1760.59	2128.92	2896.78	3361.20	3202.15	3732.47
42"(1067mm)	84"(2134mm)	TCRP-4284-	S	DK6	\$1740.12	\$2124.78	\$1842.72	\$2227.38	\$3139.10	\$3624.66	\$3488.11	\$4042.87	
		96"(2438mm)	TCRP-4296-	S	DK6	1823.08	2264.07	1931.56	2372.55	3401.91	3960.35	3798.94	4437.93

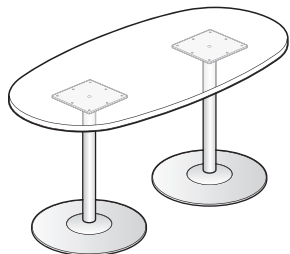

TCRP-SND

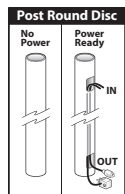

Features

- Includes 1 3/16"(30mm) thick standard top, base and hardware.
- Laminate top with knife edge or 3mm edgeband edges or wood veneer top with 3mm wood edgeband or knife edge.
- Standard table heights are 29"(737mm) and 36"(914mm).
- Table is available with black glides only.
- Ships unassembled.

Specification Tips

- Disc Base Diameter Sizes:
 - 30"(762mm) tops include 21"(533mm) two disc bases
 - 36"(914mm) tops include two 27"(686mm) disc bases
 - 42"(1067mm) tops include two 27"(686mm) disc bases
- **Specifying a cutout does not automatically include a Power Ready base.**
- Factory installed cutout is available for:
 - Specify the (F) option for a Center, Single-Sided/4 outlet Flip Top Unit
 - Specify the (J) option for a Center, Single-Sided/6 outlet Flip Top Unit
 - Specify the (M) option for a Center, Double-Sided/8 outlet Flip Top Unit
 - Specify the (Q) option for a Center, Double-Sided/12 outlet Flip Top Unit
- Power Ready Base:
 - Flip Top Unit circuit breaker plug fits Power Ready Base opening.
- **Power cord length determines the distance to building power source.**
- Separately specified:
 - Horizontal and Vertical Wire Management
 - See Accessories Price List for Power and Data Components
- Refer to Specification Guide:
 - Accessory placement and compatibility.
 - Seating capacities and base location.
 - Information on electrical components compatible with factory cut opening.
 - Power Ready base cable capacity.
- Application may require approval of local authority having jurisdiction (AHJ); ensure compliance before placing orders and installation.

To Order, Specify:

- 1) Product number, including:

① Surface Option:

- L Laminate
- W Wood

② Edge Option:

Laminate:

- J Edgeband
- F Knife

Wood:

- K Edgeband
- U Knife

③ Cutout:

- N No Cutout
- F Center, SingleSided/4 outlets, add \$33.13 list
- J Center, SingleSided/6 outlets, add \$33.13 list
- M Center, DoubleSided/8 outlets, add \$33.13 list
- Q Center, DoubleSided/12 outlets, add \$33.13 list

- 2) Laminate surface color or wood finish color.
- 3) Edgeband trim color (laminate only).
- 4) Base trim color.

Note: \$41.60 upcharge list for Metallic trim colors.

Jive Table — Dual Disc Base

Rectangle – Laminate or Wood

Height	Depth	Width	Number	① ② ③			Laminate A		Laminate B		Wood Group A		Wood Group B		
				J	F		J	F	K	U	K	U			
Base — No Power															
29"(737mm)	30"(762mm)	60"(1524mm)	TCRA-3060-	■	■	S	DN4	\$1435.64	\$1691.44	\$1518.08	\$1773.88	\$2240.14	\$2558.94	\$2431.56	\$2793.56
		72"(1829mm)	TCRA-3072-	■	■	S	DN4	1495.88	1797.72	1582.52	1884.36	2430.84	2809.22	2657.19	3088.05
36"(914mm)	72"(1829mm)	84"(2134mm)	TCRA-3672-	■	■	S	DN4	\$1561.45	\$1878.60	\$1653.13	\$1970.28	\$2639.21	\$3037.40	\$2903.11	\$3356.87
		84"(2134mm)	TCRA-3684-	■	■	S	DN4	1633.05	2001.38	1729.77	2098.10	2865.96	3330.38	3171.33	3701.65
42"(1067mm)	84"(2134mm)	84"(2134mm)	TCRA-4284-	■	■	S	DN4	\$1709.30	\$2093.96	\$1811.90	\$2196.56	\$3108.28	\$3593.84	\$3457.29	\$4012.05
		96"(2438mm)	TCRA-4296-	■	■	S	DN4	1792.26	2233.25	1900.74	2341.73	3371.09	3929.53	3768.12	4407.11
36"(914mm)	30"(762mm)	60"(1524mm)	TCRA-3060-	■	■	S	DN6	\$1446.46	\$1702.26	\$1528.90	\$1784.70	\$2250.96	\$2569.76	\$2442.38	\$2804.38
		72"(1829mm)	TCRA-3072-	■	■	S	DN6	1506.70	1808.54	1593.34	1895.18	2441.66	2820.04	2668.01	3098.87
36"(914mm)	72"(1829mm)	84"(2134mm)	TCRA-3672-	■	■	S	DN6	\$1572.27	\$1889.42	\$1663.95	\$1981.10	\$2650.03	\$3048.22	\$2913.93	\$3367.69
		84"(2134mm)	TCRA-3684-	■	■	S	DN6	1643.87	2012.20	1740.59	2108.92	2876.78	3341.20	3182.15	3712.47
42"(1067mm)	84"(2134mm)	84"(2134mm)	TCRA-4284-	■	■	S	DN6	\$1720.12	\$2104.78	\$1822.72	\$2207.38	\$3119.10	\$3604.66	\$3468.11	\$4022.87
		96"(2438mm)	TCRA-4296-	■	■	S	DN6	1803.08	2244.07	1911.56	2352.55	3381.91	3940.35	3778.94	4417.93
Base — Power Ready															
29"(737mm)	30"(762mm)	60"(1524mm)	TCRA-3060-	■	■	S	DK4	\$1455.64	\$1711.44	\$1538.08	\$1793.88	\$2260.14	\$2578.94	\$2451.56	\$2813.56
		72"(1829mm)	TCRA-3072-	■	■	S	DK4	1515.88	1817.72	1602.52	1904.36	2450.84	2829.22	2677.19	3108.05
36"(914mm)	72"(1829mm)	84"(2134mm)	TCRA-3672-	■	■	S	DK4	\$1581.45	\$1898.60	\$1673.13	\$1990.28	\$2659.21	\$3057.40	\$2923.11	\$3376.87
		84"(2134mm)	TCRA-3684-	■	■	S	DK4	1653.05	2021.38	1749.77	2118.10	2885.96	3350.38	3191.33	3721.65
42"(1067mm)	84"(2134mm)	84"(2134mm)	TCRA-4284-	■	■	S	DK4	\$1729.30	\$2113.96	\$1831.90	\$2216.56	\$3128.28	\$3613.84	\$3477.29	\$4032.05
		96"(2438mm)	TCRA-4296-	■	■	S	DK4	1812.26	2253.25	1920.74	2361.73	3391.09	3949.53	3788.12	4427.11
36"(914mm)	30"(762mm)	60"(1524mm)	TCRA-3060-	■	■	S	DK6	\$1466.46	\$1722.26	\$1548.90	\$1804.70	\$2270.96	\$2589.76	\$2462.38	\$2824.38
		72"(1829mm)	TCRA-3072-	■	■	S	DK6	1526.70	1828.54	1613.34	1915.18	2461.66	2840.04	2688.01	3118.87
36"(914mm)	72"(1829mm)	84"(2134mm)	TCRA-3672-	■	■	S	DK6	\$1592.27	\$1909.42	\$1683.95	\$2001.10	\$2670.03	\$3068.22	\$2933.93	\$3387.69
		84"(2134mm)	TCRA-3684-	■	■	S	DK6	1663.87	2032.20	1760.59	2128.92	2896.78	3361.20	3202.15	3732.47
42"(1067mm)	84"(2134mm)	84"(2134mm)	TCRA-4284-	■	■	S	DK6	\$1740.12	\$2124.78	\$1842.72	\$2227.38	\$3139.10	\$3624.66	\$3488.11	\$4042.87
		96"(2438mm)	TCRA-4296-	■	■	S	DK6	1823.08	2264.07	1931.56	2372.55	3401.91	3960.35	3798.94	4437.93

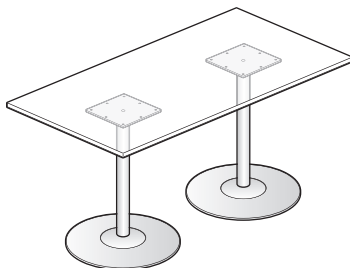

TCRA-SND

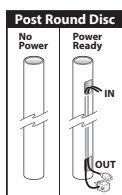

Features

- Includes 1 3/16"(30mm) thick standard top, two bases and hardware.
- Laminate top with knife edge or 3mm edgeband edges or wood veneer top with 3mm wood edgeband or knife edge.
- Standard table heights are 29"(737mm) and 36"(914mm).
- Table is available with black glides only.
- Ships unassembled.

Specification Tips

- Disc Base Diameter Sizes:
 - 30"(762mm) tops include 21"(533mm) two disc bases
 - 36"(914mm) tops include two 27"(686mm) disc bases
 - 42"(1067mm) tops include two 27"(686mm) disc bases
- **Specifying a cutout does not automatically include a Power Ready base.**
- Factory installed cutout is available for:
 - Specify the (F) option for a Center, Single-Sided/4 outlet Flip Top Unit
 - Specify the (J) option for a Center, Single-Sided/6 outlet Flip Top Unit
 - Specify the (M) option for a Center, Double-Sided/8 outlet Flip Top Unit
 - Specify the (Q) option for a Center, Double-Sided/12 outlet Flip Top Unit
- Power Ready Base:
 - Flip Top Unit circuit breaker plug fits Power Ready Base opening.
- **Power cord length determines the distance to building power source.**
- Separately specified:
 - Ganging Mechanism - Recommended for use with power between tables.
 - Horizontal and Vertical Wire Management
 - See Accessories Price List for Power and Data Components
- Refer to Specification Guide:
 - Accessory placement and compatibility.
 - Seating capacities and base location.
 - Information on electrical components compatible with factory cut opening.
 - Power Ready base cable capacity.
- Application may require approval of local authority having jurisdiction (AHJ); ensure compliance before placing orders and installation.

To Order, Specify:

- 1) Product number, including:

① Surface Option:

- L** Laminate
- W** Wood

② Edge Option:

Laminate:

- J** Edgeband
- F** Knife

Wood:

- K** Edgeband
- U** Knife

③ Cutout:

- N** No Cutout
- F** Center, Single-Sided/4 outlets, add **\$33.13** list
- J** Center, Single-Sided/6 outlets, add **\$33.13** list
- M** Center, Double-Sided/8 outlets, add **\$33.13** list
- Q** Center, Double-Sided/12 outlets, add **\$33.13** list

- 2) Laminate surface color or wood finish color.
- 3) Edgeband trim color (laminate only).
- 4) Base trim color.

Note: \$41.60 upcharge list for Metallic trim colors.

Jive Table — Dual Disc Base

Racetrack – Laminate or Wood

Height	Depth	Width	Number ① ② ③	Laminate A		Laminate B		Wood Group A		Wood Group B			
				J	F	J	F	K	U	K	U		
Base — No Power													
29"(737mm)	30"(762mm)	60"(1524mm)	TCRT-3060-	S	DN4	\$1435.64	\$1691.44	\$1518.08	\$1773.88	\$2240.14	\$2558.94	\$2431.56	\$2793.56
		72"(1829mm)	TCRT-3072-	S	DN4	1495.88	1797.72	1582.52	1884.36	2430.84	2809.22	2657.19	3088.05
36"(914mm)	72"(1829mm)	TCRT-3672-	S	DN4	\$1561.45	\$1878.60	\$1653.13	\$1970.28	\$2639.21	\$3037.40	\$2903.11	\$3356.87	
		84"(2134mm)	TCRT-3684-	S	DN4	1633.05	2001.38	1729.77	2098.10	2865.96	3330.38	3171.33	3701.65
42"(1067mm)	84"(2134mm)	TCRT-4284-	S	DN4	\$1709.30	\$2093.96	\$1811.90	\$2196.56	\$3108.28	\$3593.84	\$3457.29	\$4012.05	
		96"(2438mm)	TCRT-4296-	S	DN4	1792.26	2233.25	1900.74	2341.73	3371.09	3929.53	3768.12	4407.11
36"(914mm)	30"(762mm)	60"(1524mm)	TCRT-3060-	S	DN6	\$1446.46	\$1702.26	\$1528.90	\$1784.70	\$2250.96	\$2569.76	\$2442.38	\$2804.38
		72"(1829mm)	TCRT-3072-	S	DN6	1506.70	1808.54	1593.34	1895.18	2441.66	2820.04	2668.01	3098.87
36"(914mm)	72"(1829mm)	TCRT-3672-	S	DN6	\$1572.27	\$1889.42	\$1663.95	\$1981.10	\$2650.03	\$3048.22	\$2913.93	\$3367.69	
		84"(2134mm)	TCRT-3684-	S	DN6	1643.87	2012.20	1740.59	2108.92	2876.78	3341.20	3182.15	3712.47
42"(1067mm)	84"(2134mm)	TCRT-4284-	S	DN6	\$1720.12	\$2104.78	\$1822.72	\$2207.38	\$3119.10	\$3604.66	\$3468.11	\$4022.87	
		96"(2438mm)	TCRT-4296-	S	DN6	1803.08	2244.07	1911.56	2352.55	3381.91	3940.35	3778.94	4417.93
Base — Power Ready													
29"(737mm)	30"(762mm)	60"(1524mm)	TCRT-3060-	S	DK4	\$1455.64	\$1711.44	\$1538.08	\$1793.88	\$2260.14	\$2578.94	\$2451.56	\$2813.56
		72"(1829mm)	TCRT-3072-	S	DK4	1515.88	1817.72	1602.52	1904.36	2450.84	2829.22	2677.19	3108.05
36"(914mm)	72"(1829mm)	TCRT-3672-	S	DK4	\$1581.45	\$1898.60	\$1673.13	\$1990.28	\$2659.21	\$3057.40	\$2923.11	\$3376.87	
		84"(2134mm)	TCRT-3684-	S	DK4	1653.05	2021.38	1749.77	2118.10	2885.96	3350.38	3191.33	3721.65
42"(1067mm)	84"(2134mm)	TCRT-4284-	S	DK4	\$1729.30	\$2113.96	\$1831.90	\$2216.56	\$3128.28	\$3613.84	\$3477.29	\$4032.05	
		96"(2438mm)	TCRT-4296-	S	DK4	1812.26	2253.25	1920.74	2361.73	3391.09	3949.53	3788.12	4427.11
36"(914mm)	30"(762mm)	60"(1524mm)	TCRT-3060-	S	DK6	\$1466.46	\$1722.26	\$1548.90	\$1804.70	\$2270.96	\$2589.76	\$2462.38	\$2824.38
		72"(1829mm)	TCRT-3072-	S	DK6	1526.70	1828.54	1613.34	1915.18	2461.66	2840.04	2688.01	3118.87
36"(914mm)	72"(1829mm)	TCRT-3672-	S	DK6	\$1592.27	\$1909.42	\$1683.95	\$2001.10	\$2670.03	\$3068.22	\$2933.93	\$3387.69	
		84"(2134mm)	TCRT-3684-	S	DK6	1663.87	2032.20	1760.59	2128.92	2896.78	3361.20	3202.15	3732.47
42"(1067mm)	84"(2134mm)	TCRT-4284-	S	DK6	\$1740.12	\$2124.78	\$1842.72	\$2227.38	\$3139.10	\$3624.66	\$3488.11	\$4042.87	
		96"(2438mm)	TCRT-4296-	S	DK6	1823.08	2264.07	1931.56	2372.55	3401.91	3960.35	3798.94	4437.93

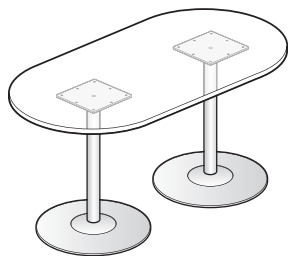

TCRT-SND

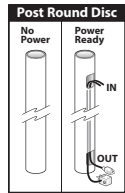

Features

- Includes 1 3/16"(30mm) thick standard top, two bases and hardware.
- Laminate top with knife edge or 3mm edgeband edges or wood veneer top with 3mm wood edgeband or knife edge.
- Standard table heights are 29"(737mm) and 36"(914mm).
- Table is available with black glides only.
- Ships unassembled.

Specification Tips

- Disc Base Diameter Sizes:
 - 30"(762mm) tops include 21"(533mm) two disc bases
 - 36"(914mm) tops include two 27"(686mm) disc bases
 - 42"(1067mm) tops include two 27"(686mm) disc bases
- **Specifying a cutout does not automatically include a Power Ready base.**
- Factory installed cutout is available for:
 - Specify the (F) option for a Center, Single-Sided/4 outlet Flip Top Unit
 - Specify the (J) option for a Center, Single-Sided/6 outlet Flip Top Unit
 - Specify the (M) option for a Center, Double-Sided/8 outlet Flip Top Unit
 - Specify the (Q) option for a Center, Double-Sided/12 outlet Flip Top Unit
- Power Ready Base:
 - Flip Top Unit circuit breaker plug fits Power Ready Base opening.
- **Power cord length determines the distance to building power source.**
- Separately specified:
 - Horizontal and Vertical Wire Management
 - See Accessories Price List for Power and Data Components
- Refer to Specification Guide:
 - Accessory placement and compatibility.
 - Seating capacities and base location.
 - Information on electrical components compatible with factory cut opening.
 - Power Ready base cable capacity.
- Application may require approval of local authority having jurisdiction (AHJ); ensure compliance before placing orders and installation.

To Order, Specify:

- 1) Product number, including:

① Surface Option:

- L Laminate
- W Wood

② Edge Option:

Laminate:

- J Edgeband
- F Knife

Wood:

- K Edgeband
- U Knife

③ Cutout:

- N No Cutout
- F Center, Single-Sided/4 outlets, add \$33.13 list
- J Center, Single-Sided/6 outlets, add \$33.13 list
- M Center, Double-Sided/8 outlets, add \$33.13 list
- Q Center, Double-Sided/12 outlets, add \$33.13 list

- 2) Laminate surface color or wood finish color.
- 3) Edgeband trim color (laminates only).
- 4) Base trim color.

Note: \$41.60 upcharge list for Metallic trim colors.

Jive Table — T-Leg — Extruded

Rectangle – Laminate or Wood

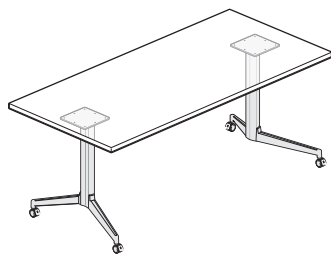

TCRA-SNT

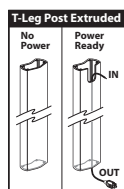
**Features**

- Includes 1-3/16" (30mm) thick top, two T-Leg bases with extruded columns, and hardware.
- Standard table heights are 29" (737mm), 36" (914mm) and 42" (1067mm).
- Laminate top with knife edge or 3mm edgeband edges or wood veneer top with 3mm wood edgeband or knife edge.
- Casters:
 - Two locking and two non-locking casters with 5/8" (16mm) adjustment.
 - Standard in black.
- Glides:
 - 5/8" (16mm) adjustment.
 - Standard in black.
- Casters and glides are not interchangeable.
- Depth and width shown in nominal dimensions.
- Ships unassembled.

Specification Tips

- Edge choice allows a flat seam between tables.
- **Specifying a cutout does not automatically include a Power Ready base.**
- Factory installed cutouts are available for:
 - Specify the (F) option for a Center, Single-Sided/4 outlet Flip Top Unit
 - Specify the (J) option for a Center, Single-Sided/6 outlet Flip Top Unit
- Power Ready Base:
 - Allows for cord management through one of the Extruded T-Legs.
 - Powered leg location determined during installation.
 - Casters and Glides:
 - Specify the (J) option for Casters on the Power Ready base (only available on 29" (737mm) high tables)
 - Specify the (K) option for Glides on the Power Ready base (available on 29" (737mm), 36" (914mm) and 42" (1067mm) high tables)
 - Flip Top Unit circuit breaker plug fits Power Ready Base opening.
- **Power cord length determines the distance to building power source.**
- Separately specified:
 - Ganging Mechanism - Recommended for use with power between tables.
 - Horizontal and Vertical Wire Management
 - Power and Data Components - Accessories
- Refer to Specification Guide:
 - Accessory placement and compatibility.
 - Seating capacities and leg locations.
 - Information on electrical components compatible with factory cut opening.
 - Power Ready base cable capacity.
- Application may require approval of local authority having jurisdiction (AHJ); ensure compliance before placing orders and installation.

To Order, Specify:

1) Product number, including:

1 Surface Option:**L** Laminate**W** Wood**2 Edge Option:**

Laminate:

J Edgeband**F** Knife

Wood:

K Edgeband**U** Knife**3 Cutout:****N** No Cutout**F** Center, Single-Sided/4 outlets, add **\$33.13** list**J** Center, Single-Sided/6 outlets, add **\$33.13** list**4 Base and Wire Management Option:**

Base - No Power:

C Casters, add **\$15.60** list (29" Height Only)**G** Glides

Base - Power Ready:

J Casters, add **\$15.60** list (29" Height Only)**K** Glides**5 Base Finish Option:****A** Painted**B** Polished, add **\$46.80** list

2) Laminate surface color or wood finish color.

3) Edgeband trim color (laminated only).

4) Base trim color.

Note: **\$41.60** upcharge list for Metallic trim colors.

Jive Table — T-Leg — Extruded

Rectangle – Laminate or Wood

Height	Depth	Width	Number	① ② ③ ④ ⑤					Laminate A		Laminate B		Wood Group A		Wood Group B	
				J	F	J	F	K	U	K	U					
Base — No Power — No Cutout																
29"(737mm)	18"(457mm)	48"(1219mm)	TCRA-1848-	S	T	4	\$ 685.00	\$ 872.37	\$ 756.52	\$ 943.89	\$1167.96	\$1398.21	\$1274.17	\$1533.81		
		54"(1372mm)	TCRA-1854-	S	T	4	704.01	910.80	776.79	983.58	1228.05	1483.42	1345.34	1634.04		
		60"(1524mm)	TCRA-1860-	S	T	4	723.20	950.44	797.24	1024.48	1288.66	1570.50	1417.16	1736.44		
		66"(1676mm)	TCRA-1866-	S	T	4	742.56	991.28	817.86	1066.58	1349.80	1659.43	1489.62	1841.02		
		72"(1829mm)	TCRA-1872-	S	T	4	762.09	1033.31	838.65	1109.87	1411.47	1750.22	1562.71	1947.78		
	24"(610mm)	36"(914mm)	TCRA-2436-	S	T	4	\$ 681.04	\$ 844.88	\$ 752.56	\$ 916.40	\$1155.90	\$1355.69	\$1259.53	\$1483.97		
		42"(1067mm)	TCRA-2442-	S	T	4	705.05	886.76	778.25	959.96	1231.90	1454.83	1349.45	1600.63		
		48"(1219mm)	TCRA-2448-	S	T	4	729.23	929.85	804.11	1004.73	1308.44	1555.83	1440.01	1719.47		
		54"(1372mm)	TCRA-2454-	S	T	4	753.58	974.13	830.14	1050.69	1385.49	1658.69	1531.20	1840.49		
		60"(1524mm)	TCRA-2460-	S	T	4	778.10	1019.62	856.34	1097.86	1463.08	1763.40	1623.04	1963.68		
30"(762mm)	36"(914mm)	66"(1676mm)	TCRA-2466-	S	T	4	802.80	1066.31	882.72	1146.23	1541.19	1869.97	1715.52	2089.05		
		72"(1829mm)	TCRA-2472-	S	T	4	827.66	1114.20	909.26	1195.80	1619.83	1978.40	1808.63	2216.60		
		42"(1067mm)	TCRA-3036-	S	T	4	\$ 714.60	\$ 890.66	\$ 788.64	\$ 964.70	\$1262.43	\$1478.03	\$1385.33	\$1628.06		
		48"(1219mm)	TCRA-3042-	S	T	4	743.94	938.39	820.08	1014.53	1355.40	1594.81	1495.27	1765.51		
		54"(1372mm)	TCRA-3048-	S	T	4	773.45	987.33	851.69	1065.57	1448.91	1713.45	1605.85	1905.14		
	36"(914mm)	60"(1524mm)	TCRA-3054-	S	T	4	803.14	1037.46	883.48	1117.80	1542.94	1833.95	1717.06	2046.94		
		66"(1676mm)	TCRA-3060-	S	T	4	833.00	1088.80	915.44	1171.24	1637.50	1956.30	1828.92	2190.92		
		72"(1829mm)	TCRA-3066-	S	T	4	863.03	1141.34	947.57	1225.88	1732.59	2080.51	1941.41	2337.08		
		60"(1524mm)	TCRA-3072-	S	T	4	893.24	1195.08	979.88	1281.72	1828.20	2206.58	2054.55	2485.41		
		66"(1676mm)	TCRA-3660-	S	T	4	\$ 887.90	\$1157.98	\$ 974.54	\$1244.62	\$1811.92	\$2149.20	\$2034.80	\$2418.16		
36"(914mm)	24"(610mm)	72"(1829mm)	TCRA-3666-	S	T	4	923.27	1216.37	1012.43	1305.53	1923.98	2291.05	2167.31	2585.11		
		60"(1524mm)	TCRA-3672-	S	T	4	958.81	1275.96	1050.49	1367.64	2036.57	2434.76	2300.47	2754.23		
		42"(1067mm)	TCRA-2436-	S	TG6	\$ 786.08	\$ 949.92	\$ 857.60	\$1021.44	\$1260.94	\$1460.73	\$1364.57	\$1589.01			
		48"(1219mm)	TCRA-2442-	S	TG6	810.09	991.80	883.29	1065.00	1336.94	1559.87	1454.49	1705.67			
		54"(1372mm)	TCRA-2448-	S	TG6	834.27	1034.89	909.15	1109.77	1413.48	1660.87	1545.05	1824.51			
	30"(762mm)	60"(1524mm)	TCRA-2454-	S	TG6	858.62	1079.17	935.18	1155.73	1490.53	1763.73	1636.24	1945.53			
		66"(1676mm)	TCRA-2460-	S	TG6	883.14	1124.66	961.38	1202.90	1568.12	1868.44	1728.08	2068.72			
		72"(1829mm)	TCRA-2466-	S	TG6	907.84	1171.35	987.76	1251.27	1646.23	1975.01	1820.56	2194.09			
		42"(1067mm)	TCRA-2472-	S	TG6	932.70	1219.24	1014.30	1300.84	1724.87	2083.44	1913.67	2321.64			
		48"(1219mm)	TCRA-3036-	S	TG6	\$ 819.64	\$ 995.70	\$ 893.68	\$1069.74	\$1367.47	\$1583.07	\$1490.37	\$1733.10			
36"(914mm)	36"(914mm)	60"(1524mm)	TCRA-3042-	S	TG6	848.98	1043.43	925.12	1119.57	1460.44	1699.85	1600.31	1870.55			
		66"(1676mm)	TCRA-3048-	S	TG6	878.49	1092.37	956.73	1170.61	1553.95	1818.49	1710.89	2010.18			
		72"(1829mm)	TCRA-3054-	S	TG6	908.18	1142.50	988.52	1222.84	1647.98	1938.99	1822.10	2151.98			
		60"(1524mm)	TCRA-3060-	S	TG6	938.04	1193.84	1020.48	1276.28	1742.54	2061.34	1933.96	2295.96			
		66"(1676mm)	TCRA-3066-	S	TG6	968.07	1246.38	1052.61	1330.92	1837.63	2185.55	2046.45	2442.12			
	36"(914mm)	72"(1829mm)	TCRA-3072-	S	TG6	998.28	1300.12	1084.92	1386.76	1933.24	2311.62	2159.59	2590.45			
		66"(1676mm)	TCRA-3666-	S	TG6	\$1028.31	\$1321.41	\$1117.47	\$1410.57	\$2029.02	\$2396.09	\$2272.35	\$2690.15			
		72"(1829mm)	TCRA-3672-	S	TG6	1063.85	1381.00	1155.53	1472.68	2141.61	2539.80	2405.51	2859.27			
		42"(1067mm)	24"(610mm)	36"(914mm)	TCRA-2436-	S	TG7	\$ 880.62	\$1044.46	\$ 952.14	\$1115.98	\$1355.48	\$1555.27	\$1459.11	\$1683.55	
				42"(1067mm)	TCRA-2442-	S	TG7	904.63	1086.34	977.83	1159.54	1431.48	1654.41	1549.03	1800.21	
48"(1219mm)	TCRA-2448-			S	TG7	928.81	1129.43	1003.69	1204.31	1508.02	1755.41	1639.59	1919.05			
54"(1372mm)	TCRA-2454-			S	TG7	953.16	1173.71	1029.72	1250.27	1585.07	1858.27	1730.78	2040.07			
60"(1524mm)	TCRA-2460-			S	TG7	977.68	1219.20	1055.92	1297.44	1662.66	1962.98	1822.62	2163.26			
30"(762mm)	66"(1676mm)		TCRA-2466-	S	TG7	1002.38	1265.89	1082.30	1345.81	1740.77	2069.55	1915.10	2288.63			
	72"(1829mm)		TCRA-2472-	S	TG7	1027.24	1313.78	1108.84	1395.38	1819.41	2177.98	2008.21	2416.18			
	36"(914mm)		TCRA-3036-	S	TG7	\$ 914.18	\$1090.24	\$ 988.22	\$1164.28	\$1462.01	\$1677.61	\$1584.91	\$1827.64			
	42"(1067mm)		TCRA-3042-	S	TG7	943.52	1137.97	1019.66	1214.11	1554.98	1794.39	1694.85	1965.09			
	48"(1219mm)		TCRA-3048-	S	TG7	973.03	1186.91	1051.27	1265.15	1648.49	1913.03	1805.43	2104.72			
36"(914mm)	36"(914mm)	54"(1372mm)	TCRA-3054-	S	TG7	1002.72	1237.04	1083.06	1317.38	1742.52	2033.53	1916.64	2246.52			
		60"(1524mm)	TCRA-3060-	S	TG7	1032.58	1288.38	1115.02	1370.82	1837.08	2155.88	2028.50	2390.50			
		66"(1676mm)	TCRA-3066-	S	TG7	1062.61	1340.92	1147.15	1425.46	1932.17	2280.09	2140.99	2536.66			
		72"(1829mm)	TCRA-3072-	S	TG7	1092.82	1394.66	1179.46	1481.30	2027.78	2406.16	2254.13	2684.99			
		66"(1676mm)	TCRA-3666-	S	TG7	\$1122.85	\$1415.95	\$1212.01	\$1505.11	\$2123.56	\$2490.63	\$2366.89	\$2784.69			
	72"(1829mm)	TCRA-3672-	S	TG7	1158.39	1475.54	1250.07	1567.22	2236.15	2634.34	2500.05	2953.81				

Jive Table — T-Leg — Extruded

Rectangle – Laminate or Wood

Height	Depth	Width	Number	① ② ③ ④ ⑤					Laminate A		Laminate B		Wood Group A		Wood Group B			
				J	F	J	F	K	U	K	U							
Base — Power Ready — No Cutout																		
29"(737mm)	18"(457mm)	48"(1219mm)	TCRA-1848-	■	■	S	■	T	■	4	\$ 705.00	\$ 892.37	\$ 776.52	\$ 963.89	\$1187.96	\$1418.21	\$1294.17	\$1553.81
		54"(1372mm)	TCRA-1854-	■	■	S	■	T	■	4	724.01	930.80	796.79	1003.58	1248.05	1503.42	1365.34	1654.04
		60"(1524mm)	TCRA-1860-	■	■	S	■	T	■	4	743.20	970.44	817.24	1044.48	1308.66	1590.50	1437.16	1756.44
		66"(1676mm)	TCRA-1866-	■	■	S	■	T	■	4	762.56	1011.28	837.86	1086.58	1369.80	1679.43	1509.62	1861.02
		72"(1829mm)	TCRA-1872-	■	■	S	■	T	■	4	782.09	1053.31	858.65	1129.87	1431.47	1770.22	1582.71	1967.78
	24"(610mm)	36"(914mm)	TCRA-2436-	■	■	S	■	T	■	4	\$ 701.04	\$ 864.88	\$ 772.56	\$ 936.40	\$1175.90	\$1375.69	\$1279.53	\$1503.97
		42"(1067mm)	TCRA-2442-	■	■	S	■	T	■	4	725.05	906.76	798.25	979.96	1251.90	1474.83	1369.45	1620.63
		48"(1219mm)	TCRA-2448-	■	■	S	■	T	■	4	749.23	949.85	824.11	1024.73	1328.44	1575.83	1460.01	1739.47
		54"(1372mm)	TCRA-2454-	■	■	S	■	T	■	4	773.58	994.13	850.14	1070.69	1405.49	1678.69	1551.20	1860.49
		60"(1524mm)	TCRA-2460-	■	■	S	■	T	■	4	798.10	1039.62	876.34	1117.86	1483.08	1783.40	1643.04	1983.68
		66"(1676mm)	TCRA-2466-	■	■	S	■	T	■	4	822.80	1086.31	902.72	1166.23	1561.19	1889.97	1735.52	2109.05
		72"(1829mm)	TCRA-2472-	■	■	S	■	T	■	4	847.66	1134.20	929.26	1215.80	1639.83	1998.40	1828.63	2236.60
	30"(762mm)	36"(914mm)	TCRA-3036-	■	■	S	■	T	■	4	\$ 734.60	\$ 910.66	\$ 808.64	\$ 984.70	\$1282.43	\$1498.03	\$1405.33	\$1648.06
		42"(1067mm)	TCRA-3042-	■	■	S	■	T	■	4	763.94	958.39	840.08	1034.53	1375.40	1614.81	1515.27	1785.51
		48"(1219mm)	TCRA-3048-	■	■	S	■	T	■	4	793.45	1007.33	871.69	1085.57	1468.91	1733.45	1625.85	1925.14
		54"(1372mm)	TCRA-3054-	■	■	S	■	T	■	4	823.14	1057.46	903.48	1137.80	1562.94	1853.95	1737.06	2066.94
		60"(1524mm)	TCRA-3060-	■	■	S	■	T	■	4	853.00	1108.80	935.44	1191.24	1657.50	1976.30	1848.92	2210.92
		66"(1676mm)	TCRA-3066-	■	■	S	■	T	■	4	883.03	1161.34	967.57	1245.88	1752.59	2100.51	1961.41	2357.08
		72"(1829mm)	TCRA-3072-	■	■	S	■	T	■	4	913.24	1215.08	999.88	1301.72	1848.20	2226.58	2074.55	2505.41
	36"(914mm)	60"(1524mm)	TCRA-3660-	■	■	S	■	T	■	4	\$ 907.90	\$1177.98	\$ 994.54	\$1264.62	\$1831.92	\$2169.20	\$2054.80	\$2438.16
66"(1676mm)		TCRA-3666-	■	■	S	■	T	■	4	943.27	1236.37	1032.43	1325.53	1943.98	2311.05	2187.31	2605.11	
72"(1829mm)		TCRA-3672-	■	■	S	■	T	■	4	978.81	1295.96	1070.49	1387.64	2056.57	2454.76	2320.47	2774.23	
36"(914mm)	24"(610mm)	36"(914mm)	TCRA-2436-	■	■	S	■	TK6	■	\$ 806.08	\$ 969.92	\$ 877.60	\$1041.44	\$1280.94	\$1480.73	\$1384.57	\$1609.01	
		42"(1067mm)	TCRA-2442-	■	■	S	■	TK6	■	830.09	1011.80	903.29	1085.00	1356.94	1579.87	1474.49	1725.67	
		48"(1219mm)	TCRA-2448-	■	■	S	■	TK6	■	854.27	1054.89	929.15	1129.77	1433.48	1680.87	1565.05	1844.51	
		54"(1372mm)	TCRA-2454-	■	■	S	■	TK6	■	878.62	1099.17	955.18	1175.73	1510.53	1783.73	1656.24	1965.53	
		60"(1524mm)	TCRA-2460-	■	■	S	■	TK6	■	903.14	1144.66	981.38	1222.90	1588.12	1888.44	1748.08	2088.72	
		66"(1676mm)	TCRA-2466-	■	■	S	■	TK6	■	927.84	1191.35	1007.76	1271.27	1666.23	1995.01	1840.56	2214.09	
		72"(1829mm)	TCRA-2472-	■	■	S	■	TK6	■	952.70	1239.24	1034.30	1320.84	1744.87	2103.44	1933.67	2341.64	
	30"(762mm)	36"(914mm)	TCRA-3036-	■	■	S	■	TK6	■	\$ 839.64	\$1015.70	\$ 913.68	\$1089.74	\$1387.47	\$1603.07	\$1510.37	\$1753.10	
		42"(1067mm)	TCRA-3042-	■	■	S	■	TK6	■	868.98	1063.43	945.12	1139.57	1480.44	1719.85	1620.31	1890.55	
		48"(1219mm)	TCRA-3048-	■	■	S	■	TK6	■	898.49	1112.37	976.73	1190.61	1573.95	1838.49	1730.89	2030.18	
		54"(1372mm)	TCRA-3054-	■	■	S	■	TK6	■	928.18	1162.50	1008.52	1242.84	1667.98	1958.99	1842.10	2171.98	
		60"(1524mm)	TCRA-3060-	■	■	S	■	TK6	■	958.04	1213.84	1040.48	1296.28	1762.54	2081.34	1953.96	2315.96	
		66"(1676mm)	TCRA-3066-	■	■	S	■	TK6	■	988.07	1266.38	1072.61	1350.92	1857.63	2205.55	2066.45	2462.12	
		72"(1829mm)	TCRA-3072-	■	■	S	■	TK6	■	1018.28	1320.12	1104.92	1406.76	1953.24	2331.62	2179.59	2610.45	
	36"(914mm)	66"(1676mm)	TCRA-3666-	■	■	S	■	TK6	■	\$1048.31	\$1341.41	\$1137.47	\$1430.57	\$2049.02	\$2416.09	\$2292.35	\$2710.15	
		72"(1829mm)	TCRA-3672-	■	■	S	■	TK6	■	1083.85	1401.00	1175.53	1492.68	2161.61	2559.80	2425.51	2879.27	
	42"(1067mm)	24"(610mm)	36"(914mm)	TCRA-2436-	■	■	S	■	TK7	■	\$ 900.62	\$1064.46	\$ 972.14	\$1135.98	\$1375.48	\$1575.27	\$1479.11	\$1703.55
			42"(1067mm)	TCRA-2442-	■	■	S	■	TK7	■	924.63	1106.34	997.83	1179.54	1451.48	1674.41	1569.03	1820.21
			48"(1219mm)	TCRA-2448-	■	■	S	■	TK7	■	948.81	1149.43	1023.69	1224.31	1528.02	1775.41	1659.59	1939.05
54"(1372mm)			TCRA-2454-	■	■	S	■	TK7	■	973.16	1193.71	1049.72	1270.27	1605.07	1878.27	1750.78	2060.07	
60"(1524mm)			TCRA-2460-	■	■	S	■	TK7	■	997.68	1239.20	1075.92	1317.44	1682.66	1982.98	1842.62	2183.26	
66"(1676mm)			TCRA-2466-	■	■	S	■	TK7	■	1022.38	1285.89	1102.30	1365.81	1760.77	2089.55	1935.10	2308.63	
72"(1829mm)			TCRA-2472-	■	■	S	■	TK7	■	1047.24	1333.78	1128.84	1415.38	1839.41	2197.98	2028.21	2436.18	
30"(762mm)		36"(914mm)	TCRA-3036-	■	■	S	■	TK7	■	\$ 934.18	\$1110.24	\$1008.22	\$1184.28	\$1482.01	\$1697.61	\$1604.91	\$1847.64	
		42"(1067mm)	TCRA-3042-	■	■	S	■	TK7	■	963.52	1157.97	1039.66	1234.11	1574.98	1814.39	1714.85	1985.09	
		48"(1219mm)	TCRA-3048-	■	■	S	■	TK7	■	993.03	1206.91	1071.27	1285.15	1668.49	1933.03	1825.43	2124.72	
		54"(1372mm)	TCRA-3054-	■	■	S	■	TK7	■	1022.72	1257.04	1103.06	1337.38	1762.52	2053.53	1936.64	2266.52	
		60"(1524mm)	TCRA-3060-	■	■	S	■	TK7	■	1052.58	1308.38	1135.02	1390.82	1857.08	2175.88	2048.50	2410.50	
		66"(1676mm)	TCRA-3066-	■	■	S	■	TK7	■	1082.61	1360.92	1167.15	1445.46	1952.17	2300.09	2160.99	2556.66	
		72"(1829mm)	TCRA-3072-	■	■	S	■	TK7	■	1112.82	1414.66	1199.46	1501.30	2047.78	2426.16	2274.13	2704.99	
36"(914mm)		66"(1676mm)	TCRA-3666-	■	■	S	■	TK7	■	\$1142.85	\$1435.95	\$1232.01	\$1525.11	\$2143.56	\$2510.63	\$2386.89	\$2804.69	
		72"(1829mm)	TCRA-3672-	■	■	S	■	TK7	■	1178.39	1495.54	1270.07	1587.22	2256.15	2654.34	2520.05	2973.81	

Jive Table — T-Leg — Extruded

Pebble – Laminate or Wood

Height	Depth	Width	Number ① ② ③ ④ ⑤	Laminate A		Laminate B		Wood Group A		Wood Group B				
				J	F	J	F	K	U	K	U			
Base — No Power — No Cutout														
29"(737mm)	30"(762mm)	48"(1219mm)	TCRP-3048-	S	T	4	\$773.45	\$987.33	\$851.69	\$1065.57	\$1448.91	\$1713.45	\$1605.85	\$1905.14
		60"(1524mm)	TCRP-3060-	S	T	4	833.00	1088.80	915.44	1171.24	1637.50	1956.30	1828.92	2190.92
		72"(1829mm)	TCRP-3072-	S	T	4	893.24	1195.08	979.88	1281.72	1828.20	2206.58	2054.55	2485.41
	36"(914mm)	60"(1524mm)	TCRP-3660-	S	T	4	\$887.90	\$1157.98	\$974.54	\$1244.62	\$1811.92	\$2149.20	\$2034.80	\$2418.16
		72"(1829mm)	TCRP-3672-	S	T	4	958.81	1275.96	1050.49	1367.64	2036.57	2434.76	2300.47	2754.23
Base — Power Ready — No Cutout														
29"(737mm)	30"(762mm)	48"(1219mm)	TCRP-3048-	S	T	4	\$793.45	\$1007.33	\$871.69	\$1085.57	\$1468.91	\$1733.45	\$1625.85	\$1925.14
		60"(1524mm)	TCRP-3060-	S	T	4	853.00	1108.80	935.44	1191.24	1657.50	1976.30	1848.92	2210.92
		72"(1829mm)	TCRP-3072-	S	T	4	913.24	1215.08	999.88	1301.72	1848.20	2226.58	2074.55	2505.41
	36"(914mm)	60"(1524mm)	TCRP-3660-	S	T	4	\$907.90	\$1177.98	\$994.54	\$1264.62	\$1831.92	\$2169.20	\$2054.80	\$2438.16
		72"(1829mm)	TCRP-3672-	S	T	4	978.81	1295.96	1070.49	1387.64	2056.57	2454.76	2320.47	2774.23



TCRP-SNT

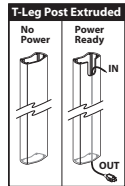

Features

- Includes 1-3/16"(30mm) thick top, two T-Leg bases with extruded columns, and hardware.
- Standard table height is 29"(737mm).
- Laminate top with knife edge or 3mm edgeband edges or wood veneer top with 3mm wood edgeband or knife edge.
- Casters:
 - Two locking and two non-locking casters with 5/8"(16mm) adjustment.
 - Standard in black.
- Glides:
 - 5/8"(16mm) adjustment.
 - Standard in black.
- Casters and glides are not interchangeable.
- Depth and width shown in nominal dimensions.
- Ships unassembled.

Specification Tips

- **Specifying a cutout does not automatically include a Power Ready base.**
- Factory installed cutout is available for:
 - Specify the (F) option for a Center, Single-Sided/4 outlet Flip Top Unit
 - Specify the (J) option for a Center, Single-Sided/6 outlet Flip Top Unit
- Power Ready Base:
 - Allows for cord management through one of the Extruded T-Leg. Powered leg location determined during installation.
 - Casters and Glides:
 - Specify the (J) option for Casters on the Power Ready base
 - Specify the (K) option for Glides on the Power Ready base
 - Flip Top Unit circuit breaker plug fits Power Ready Base opening.
- **Power cord length determines the distance to building power source.**
- Separately specified:
 - Horizontal and Vertical Wire Management
 - Power and Data Components
 - Accessories
- Refer to Specification Guide:
 - Accessory placement and compatibility.
 - Seating capacities and leg locations.
 - Information on electrical components compatible with factory cut opening.
 - Power Ready base cable capacity.
- Application may require approval of local authority having jurisdiction (AHJ); ensure compliance before placing orders and installation.

To Order, Specify:

1) Product number, including:

① Surface Option:

- L** Laminate
- W** Wood

② Edge Option:

Laminate:

- J** Edgeband
- F** Knife

Wood:

- K** Edgeband
- U** Knife

③ Cutout:

- N** No Cutout
- F** Center, Single-Sided/4 outlets, add **\$33.13** list
- J** Center, Single-Sided/6 outlets, add **\$33.13** list

④ Base and Wire Management Option:

Base - No Power:

- C** Casters, add **\$15.60** list (29" Height Only)
- G** Glides

Base - Power Ready:

- J** Casters, add **\$15.60** list (29" Height Only)
- K** Glides

⑤ Base Finish Option:

- A** Painted
- B** Polished, add **\$46.80** list

- 2) Laminate surface color or wood finish color.
- 3) Edgeband trim color (laminates only).
- 4) Base trim color.

Note: \$41.60 upcharge list for Metallic trim colors.

Jive Table — T-Leg — Extruded

Racetrack – Laminate or Wood

Height	Depth	Width	Number	Laminate A		Laminate B		Wood Group A		Wood Group B				
				J	F	J	F	K	U	K	U			
Base — No Power — No Cutout														
29"(737mm)	30"(762mm)	48"(1219mm)	TCRT-3048-	S	T	4	\$773.45	\$987.33	\$851.69	\$1065.57	\$1448.91	\$1713.45	\$1605.85	\$1905.14
		60"(1524mm)	TCRT-3060-	S	T	4	833.00	1088.80	915.44	1171.24	1637.50	1956.30	1828.92	2190.92
		72"(1829mm)	TCRT-3072-	S	T	4	893.24	1195.08	979.88	1281.72	1828.20	2206.58	2054.55	2485.41
	36"(914mm)	60"(1524mm)	TCRT-3660-	S	T	4	\$887.90	\$1157.98	\$974.54	\$1244.62	\$1811.92	\$2149.20	\$2034.80	\$2418.16
		72"(1829mm)	TCRT-3672-	S	T	4	958.81	1275.96	1050.49	1367.64	2036.57	2434.76	2300.47	2754.23
Base — Power Ready — No Cutout														
29"(737mm)	30"(762mm)	48"(1219mm)	TCRT-3048-	S	T	4	\$793.45	\$1007.33	\$871.69	\$1085.57	\$1468.91	\$1733.45	\$1625.85	\$1925.14
		60"(1524mm)	TCRT-3060-	S	T	4	853.00	1108.80	935.44	1191.24	1657.50	1976.30	1848.92	2210.92
		72"(1829mm)	TCRT-3072-	S	T	4	913.24	1215.08	999.88	1301.72	1848.20	2226.58	2074.55	2505.41
	36"(914mm)	60"(1524mm)	TCRT-3660-	S	T	4	\$907.90	\$1177.98	\$994.54	\$1264.62	\$1831.92	\$2169.20	\$2054.80	\$2438.16
		72"(1829mm)	TCRT-3672-	S	T	4	978.81	1295.96	1070.49	1387.64	2056.57	2454.76	2320.47	2774.23

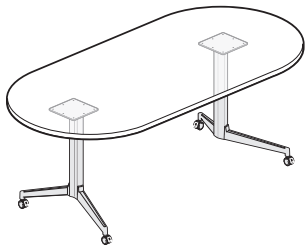

TCRT-SNT

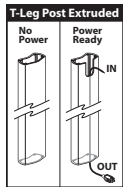

Features

- Includes 1-3/16"(30mm) thick top, two T-Leg bases with extruded columns, and hardware.
- Standard table height is 29"(737mm).
- Laminate top with knife edge or 3mm edgeband edges or wood veneer top with 3mm wood edgeband or knife edge.
- Casters:
 - Two locking and two non-locking casters with 5/8"(16mm) adjustment.
 - Standard in black.
- Glides:
 - 5/8"(16mm) adjustment.
 - Standard in black.
- Casters and glides are not interchangeable.
- Depth and width shown in nominal dimensions.
- Ships unassembled.

Specification Tips

- Specifying a cutout does not automatically include a Power Ready base.**
- Factory installed cutout is available for:
 - Specify the (F) option for a Center, Single-Sided/4 outlet Flip Top Unit
 - Specify the (J) option for a Center, Single-Sided/6 outlet Flip Top Unit
- Power Ready Base:
 - Allows for cord management through one of the Extruded T-Leg. Powered leg location determined during installation.
 - Casters and Glides:
 - Specify the (J) option for Casters on the Power Ready base
 - Specify the (K) option for Glides on the Power Ready base
 - Flip Top Unit circuit breaker plug fits Power Ready Base opening.
- Power cord length determines the distance to building power source.**
- Separately specified:
 - Horizontal and Vertical Wire Management
 - Power and Data Components
 - Accessories
- Refer to Specification Guide:
 - Accessory placement and compatibility.
 - Seating capacities and leg locations.
 - Information on electrical components compatible with factory cut opening.
 - Power Ready base cable capacity.
- Application may require approval of local authority having jurisdiction (AHJ); ensure compliance before placing orders and installation.

To Order, Specify:

- Product number, including:

1 Surface Option:

- L** Laminate
- W** Wood

2 Edge Option:

Laminate:

- J** Edgeband
- F** Knife

Wood:

- K** Edgeband
- U** Knife

3 Cutout:

- N** No Cutout
- F** Center, Single-Sided/4 outlets, add **\$33.13** list
- J** Center, Single-Sided/6 outlets, add **\$33.13** list

4 Base and Wire Management Option:

Base - No Power:

- C** Casters, add **\$15.60** list (29" Height Only)
- G** Glides

Base - Power Ready:

- J** Casters, add **\$15.60** list (29" Height Only)
- K** Glides

5 Base Finish Option:

- A** Painted
- B** Polished, add **\$46.80** list

- Laminate surface color or wood finish color.
- Edgeband trim color (laminate only).
- Base trim color.

Note: \$41.60 upcharge list for Metallic trim colors.

Jive Table — T-Leg — Extruded

Trapezoid – Laminate or Wood

Height	Depth	Width	Number						Laminate A		Laminate B		Wood Group A		Wood Group B	
				①	②	③	④	⑤	J	F	J	F	K	U	K	U
Base — No Power — No Cutout																
29"(737mm)	24"(610mm)	48"(1219mm)	TCTP-2448-	■	■	S	T	4	\$ 729.23	\$ 929.85	\$ 732.59	\$ 933.21	\$ 875.70	\$ 1123.09	\$ 916.99	\$ 1196.45
		54"(1372mm)	TCTP-2454-	■	■	S	T	4	753.58	974.13	758.62	979.17	952.75	1225.95	1008.18	1317.47
		60"(1524mm)	TCTP-2460-	■	■	S	T	4	778.10	1019.62	784.82	1026.34	1030.34	1330.66	1100.02	1440.66
		66"(1676mm)	TCTP-2466-	■	■	S	T	4	802.80	1066.31	811.20	1074.71	1108.45	1437.23	1192.50	1566.03
		72"(1829mm)	TCTP-2472-	■	■	S	T	4	827.66	1114.20	837.74	1124.28	1187.09	1545.66	1285.61	1693.58
30"(762mm)	60"(1524mm)	TCTP-3060-	■	■	S	T	4	\$ 833.00	\$1088.80	\$ 843.92	\$1099.72	\$1204.76	\$1523.56	\$1305.90	\$1667.90	
		TCTP-3066-	■	■	S	T	4	863.03	1141.34	876.05	1154.36	1299.85	1647.77	1418.39	1814.06	
		TCTP-3072-	■	■	S	T	4	893.24	1195.08	908.36	1210.20	1395.46	1773.84	1531.53	1962.39	
36"(914mm)	84"(2134mm)	TCTP-3684-	■	■	S	T	4	\$1030.41	\$1398.74	\$1055.61	\$1423.94	\$1830.58	\$2295.00	\$2045.67	\$2575.99	
Base — Power Ready — No Cutout																
29"(737mm)	24"(610mm)	48"(1219mm)	TCTP-2448-	■	■	S	T	4	\$ 749.23	\$ 949.85	\$ 752.59	\$ 953.21	\$ 895.70	\$ 1143.09	\$ 936.99	\$ 1216.45
		54"(1372mm)	TCTP-2454-	■	■	S	T	4	773.58	994.13	778.62	999.17	972.75	1245.95	1028.18	1337.47
		60"(1524mm)	TCTP-2460-	■	■	S	T	4	798.10	1039.62	804.82	1046.34	1050.34	1350.66	1120.02	1460.66
		66"(1676mm)	TCTP-2466-	■	■	S	T	4	822.80	1086.31	831.20	1094.71	1128.45	1457.23	1212.50	1586.03
		72"(1829mm)	TCTP-2472-	■	■	S	T	4	847.66	1134.20	857.74	1144.28	1207.09	1565.66	1305.61	1713.58
30"(762mm)	60"(1524mm)	TCTP-3060-	■	■	S	T	4	\$ 853.00	\$1108.80	\$ 863.92	\$1119.72	\$1224.76	\$1543.56	\$1325.90	\$1687.90	
		TCTP-3066-	■	■	S	T	4	883.03	1161.34	896.05	1174.36	1319.85	1667.77	1438.39	1834.06	
		TCTP-3072-	■	■	S	T	4	913.24	1215.08	928.36	1230.20	1415.46	1793.84	1551.53	1982.39	
36"(914mm)	84"(2134mm)	TCTP-3684-	■	■	S	T	4	\$1050.41	\$1418.74	\$1075.61	\$1443.94	\$1850.58	\$2315.00	\$2065.67	\$2595.99	

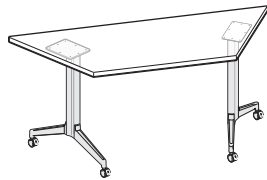

TCTP-SNT

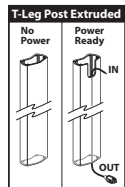

Features

- Includes 1-3/16"(30mm) thick top, two T-Leg bases with extruded columns, and hardware.
- Standard table height is 29"(737mm).
- Laminate top with knife edge or 3mm edgeband edges or wood veneer top with 3mm wood edgeband or knife edge.
- Casters:
 - Two locking and two non-locking casters with 5/8"(16mm) adjustment.
 - Standard in black.
- Glides:
 - 5/8"(16mm) adjustment.
 - Standard in black.
- Casters and glides are not interchangeable.
- Depth and width shown in nominal dimensions.
- Ships unassembled.

Specification Tips

- Edge choice allows a flat seam between tables.
- **Specifying a cutout does not automatically include a Power Ready base.**
- Factory installed cutout is available for:
 - Specify the (F) option for a Center, Single-Sided/4 outlet Flip Top Unit
 - Specify the (J) option for a Center, Single-Sided/6 outlet Flip Top Unit
- Power Ready Base:
 - Allows for cord management through one of the Extruded T-Legs. Powered leg location determined during installation.
 - Casters and Glides:
 - Specify the (J) option for Casters on the Power Ready base
 - Specify the (K) option for Glides on the Power Ready base
 - Flip Top Unit circuit breaker plug fits Power Ready Base opening.
- **Power cord length determines the distance to building power source.**
- Separately specified:
 - Ganging Mechanism - Recommended for use with power between tables.
 - Horizontal and Vertical Wire Management
 - Power and Data Components
 - Accessories
- Refer to Specification Guide:
 - Accessory placement and compatibility.
 - Seating capacities and leg locations.
 - Information on electrical components compatible with factory cut opening.
 - Power Ready base cable capacity.
- Application may require approval of local authority having jurisdiction (AHJ); ensure compliance before placing orders and installation.
- Refer to Specification Guide for accessory placement and compatibility.

To Order, Specify:

- 1) Product number, including:

① Surface Option:

- L Laminate
- W Wood

② Edge Option:

Laminate:

- J Edgeband
- F Knife

Wood:

- K Edgeband
- U Knife

③ Cutout:

- N No Cutout
- F Center, Single-Sided/4 outlets, add \$33.13 list
- J Center, Single-Sided/6 outlets, add \$33.13 list

④ Base and Wire Management Option:

Base - No Power:

- C Casters, add \$15.60 list (29" Height Only)
- G Glides

Base - Power Ready:

- J Casters, add \$15.60 list (29" Height Only)
- K Glides

⑤ Base Finish Option:

- A Painted
- B Polished, add \$76.80 list

- 2) Laminate surface color or wood finish color.
- 3) Edgeband trim color (laminates only).
- 4) Base trim color.

Note: \$41.60 upcharge list for Metallic trim colors.

Jive Table — T-Leg — Round

Rectangle – Laminate or Wood

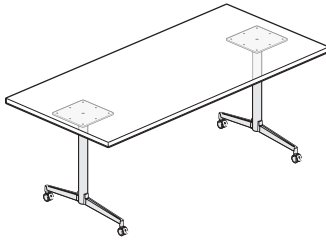

TCRA-SNF

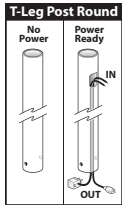
**Features**

- Includes 1-3/16" (30mm) thick top, two T-Leg bases with round columns, and hardware.
- Standard table heights are 29" (737mm), 36" (914mm) and 42" (1067mm).
- Laminate top with knife edge or 3mm edgeband edges or wood veneer top with 3mm wood edgeband or knife edge.
- Casters:
 - Two locking and two non-locking casters with 5/8" (16mm) adjustment.
 - Standard in black.
- Glides:
 - 5/8" (16mm) adjustment.
 - Standard in black.
- Casters and glides are not interchangeable.
- Depth and width shown in nominal dimensions.
- Ships unassembled.

Specification Tips

- No casters on 36" (914mm) or 42" (1067mm) height tables.
- Edge choice allows a flat seam between tables.
- **Specifying a cutout does not automatically include a Power Ready base.**
- Factory installed cutout is available for:
 - Specify the (F) option for a Center, Single-Sided/4 outlet Flip Top Unit
 - Specify the (J) option for a Center, Single-Sided/6 outlet Flip Top Unit
- Power Ready Base:
 - Allows for cord management through one of the Round T-Legs.
 - Powered leg location determined during installation.
 - Casters and Glides:
 - Specify the (J) option for Casters on the Power Ready base (only available on 29" (737mm) high tables)
 - Specify the (K) option for Glides on the Power Ready base (available on 29" (737mm), 36" (914mm) and 42" (1067mm) high tables)
 - Flip Top Unit circuit breaker plug fits Power Ready Base opening.
- **Power cord length determines the distance to building power source.**
- Separately specified:
 - Ganging Mechanism - Recommended for use with power between tables.
 - Horizontal and Vertical Wire Management
 - Power and Data Components
 - Accessories
- Refer to Specification Guide:
 - Accessory placement and compatibility.
 - Seating capacities and leg locations.
 - Information on electrical components compatible with factory cut opening.
 - Power Ready base cable capacity.
- Application may require approval of local authority having jurisdiction (AHJ); ensure compliance before placing orders and installation.

To Order, Specify:

1) Product number, including:

1 Surface Option:

- L** Laminate
- W** Wood

2 Edge Option:

Laminate:

- J** Edgeband
- F** Knife

Wood:

- K** Edgeband
- U** Knife

3 Cutout:

- N** No Cutout
- F** Center, Single-Sided/4 outlets, add **\$33.13** list
- J** Center, Single-Sided/6 outlets, add **\$33.13** list

4 Base and Wire Management Option:

Base - No Power:

- C** Casters, add **\$15.60** list (29" Height Only)
- G** Glides

Base - Power Ready:

- J** Casters, add **\$15.60** list (29" Height Only)
- K** Glides

5 Base Finish Option:

- A** Painted
- B** Polished, add **\$46.80** list

2) Laminate surface color or wood finish color.

3) Edgeband trim color (laminate only).

4) Base trim color.

Note: \$41.60 upcharge list for Metallic trim colors.

Jive Table — T-Leg — Round

Rectangle – Laminate or Wood

Height	Depth	Width	Number						Laminate A		Laminate B		Wood Group A		Wood Group B	
				①	②	③	④	⑤	J	F	J	F	K	U	K	U
Base — No Power — No Cutout																
29"(737mm)	18"(457mm)	48"(1219mm)	TCRA-1848-	S	F	4	\$546.14	\$ 733.51	\$ 617.66	\$ 805.03	\$1029.10	\$1259.35	\$1135.31	\$1394.95		
		54"(1372mm)	TCRA-1854-	S	F	4	565.15	771.94	637.93	844.72	1089.19	1344.56	1206.48	1495.18		
		60"(1524mm)	TCRA-1860-	S	F	4	584.34	811.58	658.38	885.62	1149.80	1431.64	1278.30	1597.58		
		66"(1676mm)	TCRA-1866-	S	F	4	603.70	852.42	679.00	927.72	1210.94	1520.57	1350.76	1702.16		
		72"(1829mm)	TCRA-1872-	S	F	4	623.23	894.45	699.79	971.01	1272.61	1611.36	1423.85	1808.92		
	24"(610mm)	36"(914mm)	TCRA-2436-	S	F	4	\$542.18	\$ 706.02	\$ 613.70	\$ 777.54	\$1017.04	\$1216.83	\$1120.67	\$1345.11		
		42"(1067mm)	TCRA-2442-	S	F	4	566.19	747.90	639.39	821.10	1093.04	1315.97	1210.59	1461.77		
		48"(1219mm)	TCRA-2448-	S	F	4	590.37	790.99	665.25	865.87	1169.58	1416.97	1301.15	1580.61		
		54"(1372mm)	TCRA-2454-	S	F	4	614.72	835.27	691.28	911.83	1246.63	1519.83	1392.34	1701.63		
		60"(1524mm)	TCRA-2460-	S	F	4	639.24	880.76	717.48	959.00	1324.22	1624.54	1484.18	1824.82		
30"(762mm)	24"(610mm)	66"(1676mm)	TCRA-2466-	S	F	4	663.94	927.45	743.86	1007.37	1402.33	1731.11	1576.66	1950.19		
		72"(1829mm)	TCRA-2472-	S	F	4	688.80	975.34	770.40	1056.94	1480.97	1839.54	1669.77	2077.74		
		36"(914mm)	TCRA-3036-	S	F	4	\$575.74	\$ 751.80	\$ 649.78	\$ 825.84	\$1123.57	\$1339.17	\$1246.47	\$1489.20		
		42"(1067mm)	TCRA-3042-	S	F	4	605.08	799.53	681.22	875.67	1216.54	1455.95	1356.41	1626.65		
		48"(1219mm)	TCRA-3048-	S	F	4	634.59	848.47	712.83	926.71	1310.05	1574.59	1466.99	1766.28		
	36"(914mm)	54"(1372mm)	TCRA-3054-	S	F	4	664.28	898.60	744.62	978.94	1404.08	1695.09	1578.20	1908.08		
		60"(1524mm)	TCRA-3060-	S	F	4	694.14	949.94	776.58	1032.38	1498.64	1817.44	1690.06	2052.06		
		66"(1676mm)	TCRA-3066-	S	F	4	724.17	1002.48	808.71	1087.02	1593.73	1941.65	1802.55	2198.22		
		72"(1829mm)	TCRA-3072-	S	F	4	754.38	1056.22	841.02	1142.86	1689.34	2067.72	1915.69	2346.55		
		42"(1067mm)	TCRA-3660-	S	F	4	\$749.04	\$1019.12	\$ 835.68	\$1105.76	\$1673.06	\$2010.34	\$1895.94	\$2279.30		
36"(914mm)	24"(610mm)	66"(1676mm)	TCRA-3666-	S	F	4	784.41	1077.51	873.57	1166.67	1785.12	2152.19	2028.45	2446.25		
		72"(1829mm)	TCRA-3672-	S	F	4	819.95	1137.10	911.63	1228.78	1897.71	2295.90	2161.61	2615.37		
		36"(914mm)	TCRA-2436-	S	FG6		\$647.22	\$ 811.06	\$ 718.74	\$ 882.58	\$1122.08	\$1321.87	\$1225.71	\$1450.15		
		42"(1067mm)	TCRA-2442-	S	FG6		671.23	852.94	744.43	926.14	1198.08	1421.01	1315.63	1566.81		
		48"(1219mm)	TCRA-2448-	S	FG6		695.41	896.03	770.29	970.91	1274.62	1522.01	1406.19	1685.65		
	30"(762mm)	54"(1372mm)	TCRA-2454-	S	FG6		719.76	940.31	796.32	1016.87	1351.67	1624.87	1497.38	1806.67		
		60"(1524mm)	TCRA-2460-	S	FG6		744.28	985.80	822.52	1064.04	1429.26	1729.58	1589.22	1929.86		
		66"(1676mm)	TCRA-2466-	S	FG6		768.98	1032.49	848.90	1112.41	1507.37	1836.15	1681.70	2055.23		
		72"(1829mm)	TCRA-2472-	S	FG6		793.84	1080.38	875.44	1161.98	1586.01	1944.58	1774.81	2182.78		
		36"(914mm)	TCRA-3036-	S	FG6		\$680.78	\$ 856.84	\$ 754.82	\$ 930.88	\$1228.61	\$1444.21	\$1351.51	\$1594.24		
36"(914mm)	24"(610mm)	42"(1067mm)	TCRA-3042-	S	FG6		710.12	904.57	786.26	980.71	1321.58	1560.99	1461.45	1731.69		
		48"(1219mm)	TCRA-3048-	S	FG6		739.63	953.51	817.87	1031.75	1415.09	1679.63	1572.03	1871.32		
		54"(1372mm)	TCRA-3054-	S	FG6		769.32	1003.64	849.66	1083.98	1509.12	1800.13	1683.24	2013.12		
		60"(1524mm)	TCRA-3060-	S	FG6		799.18	1054.98	881.62	1137.42	1603.68	1922.48	1795.10	2157.10		
		66"(1676mm)	TCRA-3066-	S	FG6		829.21	1107.52	913.75	1192.06	1698.77	2046.69	1907.59	2303.26		
	36"(914mm)	72"(1829mm)	TCRA-3072-	S	FG6		859.42	1161.26	946.06	1247.90	1794.38	2172.76	2020.73	2451.59		
		66"(1676mm)	TCRA-3666-	S	FG6		\$889.45	\$1182.55	\$ 978.61	\$1271.71	\$1890.16	\$2257.23	\$2133.49	\$2551.29		
		72"(1829mm)	TCRA-3672-	S	FG6		924.99	1242.14	1016.67	1333.82	2002.75	2400.94	2266.65	2720.41		
		42"(1067mm)	TCRA-2436-	S	FG7		\$699.74	\$ 863.58	\$ 771.26	\$ 935.10	\$1174.60	\$1374.39	\$1278.23	\$1502.67		
		48"(1219mm)	TCRA-2442-	S	FG7		723.75	905.46	796.95	978.66	1250.60	1473.53	1368.15	1619.33		
42"(1067mm)	24"(610mm)	54"(1372mm)	TCRA-2448-	S	FG7		747.93	948.55	822.81	1023.43	1327.14	1574.53	1458.71	1738.17		
		60"(1524mm)	TCRA-2454-	S	FG7		772.28	992.83	848.84	1069.39	1404.19	1677.39	1549.90	1859.19		
		66"(1676mm)	TCRA-2460-	S	FG7		796.80	1038.32	875.04	1116.56	1481.78	1782.10	1641.74	1982.38		
		72"(1829mm)	TCRA-2466-	S	FG7		821.50	1085.01	901.42	1164.93	1559.89	1888.67	1734.22	2107.75		
		36"(914mm)	TCRA-2472-	S	FG7		846.36	1132.90	927.96	1214.50	1638.53	1997.10	1827.33	2235.30		
	30"(762mm)	36"(914mm)	TCRA-3036-	S	FG7		\$733.30	\$ 909.36	\$ 807.34	\$ 983.40	\$1281.13	\$1496.73	\$1404.03	\$1646.76		
		42"(1067mm)	TCRA-3042-	S	FG7		762.64	957.09	838.78	1033.23	1374.10	1613.51	1513.97	1784.21		
		48"(1219mm)	TCRA-3048-	S	FG7		792.15	1006.03	870.39	1084.27	1467.61	1732.15	1624.55	1923.84		
		54"(1372mm)	TCRA-3054-	S	FG7		821.84	1056.16	902.18	1136.50	1561.64	1852.65	1735.76	2065.64		
		60"(1524mm)	TCRA-3060-	S	FG7		851.70	1107.50	934.14	1189.94	1656.20	1975.00	1847.62	2209.62		
36"(914mm)	66"(1676mm)	TCRA-3066-	S	FG7		881.73	1160.04	966.27	1244.58	1751.29	2099.21	1960.11	2355.78			
	72"(1829mm)	TCRA-3072-	S	FG7		911.94	1213.78	998.58	1300.42	1846.90	2225.28	2073.25	2504.11			
	66"(1676mm)	TCRA-3666-	S	FG7		\$941.97	\$1235.07	\$1031.13	\$1324.23	\$1942.68	\$2309.75	\$2186.01	\$2603.81			
	72"(1829mm)	TCRA-3672-	S	FG7		977.51	1294.66	1069.19	1386.34	2055.27	2453.46	2319.17	2772.93			

Jive Table — T-Leg — Round

Rectangle – Laminate or Wood

Height	Depth	Width	Number	① ② ③ ④ ⑤					Laminate A		Laminate B		Wood Group A		Wood Group B	
				J	F	J	F	K	U	K	U					
Base — Power Ready — No Cutout																
29"(737mm)	18"(457mm)	48"(1219mm)	TCRA-1848-	S	F	4	\$566.14	\$ 753.51	\$ 637.66	\$ 825.03	\$1049.10	\$1279.35	\$1155.31	\$1414.95		
		54"(1372mm)	TCRA-1854-	S	F	4	585.15	791.94	657.93	864.72	1109.19	1364.56	1226.48	1515.18		
		60"(1524mm)	TCRA-1860-	S	F	4	604.34	831.58	678.38	905.62	1169.80	1451.64	1298.30	1617.58		
		66"(1676mm)	TCRA-1866-	S	F	4	623.70	872.42	699.00	947.72	1230.94	1540.57	1370.76	1722.16		
		72"(1829mm)	TCRA-1872-	S	F	4	643.23	914.45	719.79	991.01	1292.61	1631.36	1443.85	1828.92		
		24"(610mm)	36"(914mm)	TCRA-2436-	S	F	4	\$562.18	\$ 726.02	\$ 633.70	\$ 797.54	\$1037.04	\$1236.83	\$1140.67	\$1365.11	
42"(1067mm)	TCRA-2442-		S	F	4	586.19	767.90	659.39	841.10	1113.04	1335.97	1230.59	1481.77			
48"(1219mm)	TCRA-2448-		S	F	4	610.37	810.99	685.25	885.87	1189.58	1436.97	1321.15	1600.61			
54"(1372mm)	TCRA-2454-		S	F	4	634.72	855.27	711.28	931.83	1266.63	1539.83	1412.34	1721.63			
60"(1524mm)	TCRA-2460-		S	F	4	659.24	900.76	737.48	979.00	1344.22	1644.54	1504.18	1844.82			
66"(1676mm)	TCRA-2466-		S	F	4	683.94	947.45	763.86	1027.37	1422.33	1751.11	1596.66	1970.19			
72"(1829mm)	TCRA-2472-		S	F	4	708.80	995.34	790.40	1076.94	1500.97	1859.54	1689.77	2097.74			
30"(762mm)		36"(914mm)	TCRA-3036-	S	F	4	\$595.74	\$ 771.80	\$ 669.78	\$ 845.84	\$1143.57	\$1359.17	\$1266.47	\$1509.20		
		42"(1067mm)	TCRA-3042-	S	F	4	625.08	819.53	701.22	895.67	1236.54	1475.95	1376.41	1646.65		
		48"(1219mm)	TCRA-3048-	S	F	4	654.59	868.47	732.83	946.71	1330.05	1594.59	1486.99	1786.28		
		54"(1372mm)	TCRA-3054-	S	F	4	684.28	918.60	764.62	998.94	1424.08	1715.09	1598.20	1928.08		
		60"(1524mm)	TCRA-3060-	S	F	4	714.14	969.94	796.58	1052.38	1518.64	1837.44	1710.06	2072.06		
		66"(1676mm)	TCRA-3066-	S	F	4	744.17	1022.48	828.71	1107.02	1613.73	1961.65	1822.55	2218.22		
		72"(1829mm)	TCRA-3072-	S	F	4	774.38	1076.22	861.02	1162.86	1709.34	2087.72	1935.69	2366.55		
36"(914mm)		60"(1524mm)	TCRA-3660-	S	F	4	\$769.04	\$1039.12	\$ 855.68	\$1125.76	\$1693.06	\$2030.34	\$1915.94	\$2299.30		
		66"(1676mm)	TCRA-3666-	S	F	4	804.41	1097.51	893.57	1186.67	1805.12	2172.19	2048.45	2466.25		
		72"(1829mm)	TCRA-3672-	S	F	4	839.95	1157.10	931.63	1248.78	1917.71	2315.90	2181.61	2635.37		
36"(914mm)	24"(610mm)	36"(914mm)	TCRA-2436-	S	FK6		\$667.22	\$ 831.06	\$ 738.74	\$ 902.58	\$1142.08	\$1341.87	\$1245.71	\$1470.15		
		42"(1067mm)	TCRA-2442-	S	FK6		691.23	872.94	764.43	946.14	1218.08	1441.01	1335.63	1586.81		
		48"(1219mm)	TCRA-2448-	S	FK6		715.41	916.03	790.29	990.91	1294.62	1542.01	1426.19	1705.65		
		54"(1372mm)	TCRA-2454-	S	FK6		739.76	960.31	816.32	1036.87	1371.67	1644.87	1517.38	1826.67		
		60"(1524mm)	TCRA-2460-	S	FK6		764.28	1005.80	842.52	1084.04	1449.26	1749.58	1609.22	1949.86		
		66"(1676mm)	TCRA-2466-	S	FK6		788.98	1052.49	868.90	1132.41	1527.37	1856.15	1701.70	2075.23		
		72"(1829mm)	TCRA-2472-	S	FK6		813.84	1100.38	895.44	1181.98	1606.01	1964.58	1794.81	2202.78		
		30"(762mm)		36"(914mm)	TCRA-3036-	S	FK6		\$700.78	\$ 876.84	\$ 774.82	\$ 950.88	\$1248.61	\$1464.21	\$1371.51	\$1614.24
				42"(1067mm)	TCRA-3042-	S	FK6		730.12	924.57	806.26	1000.71	1341.58	1580.99	1481.45	1751.69
				48"(1219mm)	TCRA-3048-	S	FK6		759.63	973.51	837.87	1051.75	1435.09	1699.63	1592.03	1891.32
				54"(1372mm)	TCRA-3054-	S	FK6		789.32	1023.64	869.66	1103.98	1529.12	1820.13	1703.24	2033.12
				60"(1524mm)	TCRA-3060-	S	FK6		819.18	1074.98	901.62	1157.42	1623.68	1942.48	1815.10	2177.10
				66"(1676mm)	TCRA-3066-	S	FK6		849.21	1127.52	933.75	1212.06	1718.77	2066.69	1927.59	2323.26
				72"(1829mm)	TCRA-3072-	S	FK6		879.42	1181.26	966.06	1267.90	1814.38	2192.76	2040.73	2471.59
36"(914mm)		66"(1676mm)	TCRA-3666-	S	FK6		\$909.45	\$1202.55	\$ 998.61	\$1291.71	\$1910.16	\$2277.23	\$2153.49	\$2571.29		
		72"(1829mm)	TCRA-3672-	S	FK6		944.99	1262.14	1036.67	1353.82	2022.75	2420.94	2286.65	2740.41		
42"(1067mm)	24"(610mm)	36"(914mm)	TCRA-2436-	S	FK7		\$719.74	\$ 883.58	\$ 791.26	\$ 955.10	\$1194.60	\$1394.39	\$1298.23	\$1522.67		
		42"(1067mm)	TCRA-2442-	S	FK7		743.75	925.46	816.95	998.66	1270.60	1493.53	1388.15	1639.33		
		48"(1219mm)	TCRA-2448-	S	FK7		767.93	968.55	842.81	1043.43	1347.14	1594.53	1478.71	1758.17		
		54"(1372mm)	TCRA-2454-	S	FK7		792.28	1012.83	868.84	1089.39	1424.19	1697.39	1569.90	1879.19		
		60"(1524mm)	TCRA-2460-	S	FK7		816.80	1058.32	895.04	1136.56	1501.78	1802.10	1661.74	2002.38		
		66"(1676mm)	TCRA-2466-	S	FK7		841.50	1105.01	921.42	1184.93	1579.89	1908.67	1754.22	2127.75		
		72"(1829mm)	TCRA-2472-	S	FK7		866.36	1152.90	947.96	1234.50	1658.53	2017.10	1847.33	2255.30		
		30"(762mm)		36"(914mm)	TCRA-3036-	S	FK7		\$753.30	\$ 929.36	\$ 827.34	\$1003.40	\$1301.13	\$1516.73	\$1424.03	\$1666.76
				42"(1067mm)	TCRA-3042-	S	FK7		782.64	977.09	858.78	1053.23	1394.10	1633.51	1533.97	1804.21
				48"(1219mm)	TCRA-3048-	S	FK7		812.15	1026.03	890.39	1104.27	1487.61	1752.15	1644.55	1943.84
				54"(1372mm)	TCRA-3054-	S	FK7		841.84	1076.16	922.18	1156.50	1581.64	1872.65	1755.76	2085.64
				60"(1524mm)	TCRA-3060-	S	FK7		871.70	1127.50	954.14	1209.94	1676.20	1995.00	1867.62	2229.62
				66"(1676mm)	TCRA-3066-	S	FK7		901.73	1180.04	986.27	1264.58	1771.29	2119.21	1980.11	2375.78
				72"(1829mm)	TCRA-3072-	S	FK7		931.94	1233.78	1018.58	1320.42	1866.90	2245.28	2093.25	2524.11
36"(914mm)		66"(1676mm)	TCRA-3666-	S	FK7		\$961.97	\$1255.07	\$1051.13	\$1344.23	\$1962.68	\$2329.75	\$2206.01	\$2623.81		
		72"(1829mm)	TCRA-3672-	S	FK7		997.51	1314.66	1089.19	1406.34	2075.27	2473.46	2339.17	2792.93		

Jive Table — T-Leg — Round

Pebble – Laminate or Wood

Height	Depth	Width	Number ① ② ③ ④ ⑤	Laminate A		Laminate B		Wood Group A		Wood Group B				
				J	F	J	F	K	U	K	U			
Base — No Power — No Top Cutout														
29"(737mm)	30"(762mm)	48"(1219mm)	TCRP-3048-	S	F	4	\$634.59	\$ 848.47	\$712.83	\$ 926.71	\$1310.05	\$1574.59	\$1466.99	\$1766.28
		60"(1524mm)	TCRP-3060-	S	F	4	694.14	949.94	776.58	1032.38	1498.64	1817.44	1690.06	2052.06
		72"(1829mm)	TCRP-3072-	S	F	4	754.38	1056.22	841.02	1142.86	1689.34	2067.72	1915.69	2346.55
	36"(914mm)	60"(1524mm)	TCRP-3660-	S	F	4	\$749.04	\$1019.12	\$835.68	\$1105.76	\$1673.06	\$2010.34	\$1895.94	\$2279.30
		72"(1829mm)	TCRP-3672-	S	F	4	819.95	1137.10	911.63	1228.78	1897.71	2295.90	2161.61	2615.37
Base — Power Ready — No Top Cutout														
29"(737mm)	30"(762mm)	48"(1219mm)	TCRP-3048-	S	F	4	\$654.59	\$ 868.47	\$732.83	\$ 946.71	\$1330.05	\$1594.59	\$1486.99	\$1786.28
		60"(1524mm)	TCRP-3060-	S	F	4	714.14	969.94	796.58	1052.38	1518.64	1837.44	1710.06	2072.06
		72"(1829mm)	TCRP-3072-	S	F	4	774.38	1076.22	861.02	1162.86	1709.34	2087.72	1935.69	2366.55
	36"(914mm)	60"(1524mm)	TCRP-3660-	S	F	4	\$769.04	\$1039.12	\$855.68	\$1125.76	\$1693.06	\$2030.34	\$1915.94	\$2299.30
		72"(1829mm)	TCRP-3672-	S	F	4	839.95	1157.10	931.63	1248.78	1917.71	2315.90	2181.61	2635.37



TCRP-SNF

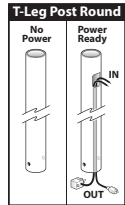

Features

- Includes 1-3/16"(30mm) thick top, two T-Leg bases with round columns, and hardware.
- Standard table height is 29"(737mm).
- Laminate top with knife edge or 3mm edgeband edges or wood veneer top with 3mm wood edgeband or knife edge.
- Casters:
 - Two locking and two non-locking casters with 5/8"(16mm) adjustment.
 - Standard in black.
- Glides:
 - 5/8"(16mm) adjustment.
 - Standard in black.
- Casters and glides are not interchangeable.
- Depth and width shown in nominal dimensions.
- Ships unassembled.

Specification Tips

- **Specifying a cutout does not automatically include a Power Ready base.**
- Factory installed cutout is available for:
 - Specify the (F) option for a Center, Single-Sided/4 outlet Flip Top Unit
 - Specify the (J) option for a Center, Single-Sided/6 outlet Flip Top Unit
- Power Ready Base:
 - Allows for cord management through one of the Round T-Legs.
 - Powered leg location determined during installation.
 - Casters and Glides:
 - Specify the (J) option for Casters on the Power Ready base
 - Specify the (K) option for Glides on the Power Ready base
 - Flip Top Unit circuit breaker plug fits Power Ready Base opening.
- **Power cord length determines the distance to building power source.**
- Separately specified:
 - Horizontal and Vertical Wire Management
 - Power and Data Components
 - Accessories
- Refer to Specification Guide:
 - Accessory placement and compatibility.
 - Seating capacities and leg locations.
 - Information on electrical components compatible with factory cut opening.
 - Power Ready base cable capacity.
- Application may require approval of local authority having jurisdiction (AHJ); ensure compliance before placing orders and installation.

To Order, Specify:

1) Product number, including:

① Surface Option:

- L** Laminate
- W** Wood

② Edge Option:

Laminate:

- J** Edgeband
- F** Knife

Wood:

- K** Edgeband
- U** Knife

③ Cutout:

- N** No Cutout
- F** Center, Single-Sided/4 outlets, add **\$33.13** list
- J** Center, Single-Sided/6 outlets, add **\$33.13** list

④ Base and Wire Management Option:

Base - No Power:

- C** Casters, add **\$15.60** list (29" Height Only)
- G** Glides

Base - Power Ready:

- J** Casters, add **\$15.60** list (29" Height Only)
- K** Glides

⑤ Base Finish Option:

- A** Painted
- B** Polished, add **\$46.80** list

- 2) Laminate surface color or wood finish color.
- 3) Edgeband trim color (laminates only).
- 4) Base trim color.

Note: \$41.60 upcharge list for Metallic trim colors.

Jive Table — T-Leg — Round

Racetrack – Laminate or Wood

Height	Depth	Width	Number						Laminate A		Laminate B		Wood Group A		Wood Group B	
				①	②	③	④	⑤	J	F	J	F	K	U	K	U
Base — No Power — No Cutout																
29"(737mm)	30"(762mm)	48"(1219mm)	TCRT-3048-	■	S	E	■	4	\$634.59	\$ 848.47	\$712.83	\$ 926.71	\$1310.05	\$1574.59	\$1466.99	\$1766.28
		60"(1524mm)	TCRT-3060-	■	S	E	■	4	694.14	949.94	776.58	1032.38	1498.64	1817.44	1690.06	2052.06
		72"(1829mm)	TCRT-3072-	■	S	E	■	4	754.38	1056.22	841.02	1142.86	1689.34	2067.72	1915.69	2346.55
	36"(914mm)	60"(1524mm)	TCRT-3660-	■	S	E	■	4	\$749.04	\$1019.12	\$835.68	\$1105.76	\$1673.06	\$2010.34	\$1895.94	\$2279.30
72"(1829mm)		TCRT-3672-	■	S	E	■	4	819.95	1137.10	911.63	1228.78	1897.71	2295.90	2161.61	2615.37	
Base — Power Ready — No Cutout																
29"(737mm)	30"(762mm)	48"(1219mm)	TCRT-3048-	■	S	E	■	4	\$654.59	\$ 868.47	\$732.83	\$ 946.71	\$1330.05	\$1594.59	\$1486.99	\$1786.28
		60"(1524mm)	TCRT-3060-	■	S	E	■	4	714.14	969.94	796.58	1052.38	1518.64	1837.44	1710.06	2072.06
		72"(1829mm)	TCRT-3072-	■	S	E	■	4	774.38	1076.22	861.02	1162.86	1709.34	2087.72	1935.69	2366.55
	36"(914mm)	60"(1524mm)	TCRT-3660-	■	S	E	■	4	\$769.04	\$1039.12	\$855.68	\$1125.76	\$1693.06	\$2030.34	\$1915.94	\$2299.30
72"(1829mm)		TCRT-3672-	■	S	E	■	4	839.95	1157.10	931.63	1248.78	1917.71	2315.90	2181.61	2635.37	



TCRT-SNE

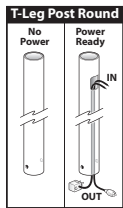

Features

- Includes 1-3/16"(30mm) thick top, two T-Leg bases with extruded columns, and hardware.
- Standard table height is 29"(737mm).
- Laminate top with knife edge or 3mm edgeband edges or wood veneer top with 3mm wood edgeband or knife edge.
- Casters:
 - Two locking and two non-locking casters with 5/8"(16mm) adjustment.
 - Standard in black.
- Glides:
 - 5/8"(16mm) adjustment.
 - Standard in black.
- Casters and glides are not interchangeable.
- Depth and width shown in nominal dimensions.
- Ships unassembled.

Specification Tips

- Specifying a cutout does not automatically include a Power Ready base.**
- Factory installed cutout is available for:
 - Specify the (F) option for a Center, Single-Sided/4 outlet Flip Top Unit
 - Specify the (J) option for a Center, Single-Sided/6 outlet Flip Top Unit
- Power Ready Base:
 - Allows for cord management through one of the Round T-Leg. Powered leg location determined during installation.
 - Casters and Glides:
 - Specify the (J) option for Casters on the Power Ready base
 - Specify the (K) option for Glides on the Power Ready base
 - Flip Top Unit circuit breaker plug fits Power Ready Base opening.
- Power cord length determines the distance to building power source.**
- Separately specified:
 - Horizontal and Vertical Wire Management
 - Power and Data Components
 - Accessories
- Refer to Specification Guide:
 - Accessory placement and compatibility.
 - Seating capacities and leg locations.
 - Information on electrical components compatible with factory cut opening.
 - Power Ready base cable capacity.
- Application may require approval of local authority having jurisdiction (AHJ); ensure compliance before placing orders and installation.

To Order, Specify:

- Product number, including:

① Surface Option:

- L** Laminate
- W** Wood

② Edge Option:

Laminate:

- J** Edgeband
- F** Knife

Wood:

- K** Edgeband
- U** Knife

③ Cutout:

- N** No Cutout
- F** Center, Single-Sided/4 outlets, add **\$33.13** list
- J** Center, Single-Sided/6 outlets, add **\$33.13** list

④ Base Wire Management Option:

Base - No Power:

- C** Casters, add **\$15.60** list (29" Height Only)
- G** Glides

Base - Power Ready:

- J** Casters, add **\$15.60** list (29" Height Only)
- K** Glides

⑤ Base Finish Option:

- A** Painted
- B** Polished, add **\$46.80** list

- Laminate surface color or wood finish color.
- Edgeband trim color (laminate only).
- Base trim color.

Note: \$41.60 upcharge list for Metallic trim colors.

Jive Table — T-Leg — Round

Trapezoid – Laminate or Wood

Height	Depth	Width	Number	Laminate A		Laminate B		Wood Group A		Wood Group B						
				①	②	③	④	⑤	J	F	J	F	K	U	K	U
Base — No Power — No Cutout																
29"(737mm)	24"(610mm)	48"(1219mm)	TCTP-2448-	■	S	F	■	4	\$590.37	\$ 790.99	\$593.73	\$ 794.35	\$ 736.84	\$ 984.23	\$ 778.13	\$1057.59
		54"(1372mm)	TCTP-2454-	■	S	F	■	4	614.72	835.27	619.76	840.31	813.89	1087.09	869.32	1178.61
		60"(1524mm)	TCTP-2460-	■	S	F	■	4	639.24	880.76	645.96	887.48	891.48	1191.80	961.16	1301.80
		66"(1676mm)	TCTP-2466-	■	S	F	■	4	663.94	927.45	672.34	935.85	969.59	1298.37	1053.64	1427.17
		72"(1829mm)	TCTP-2472-	■	S	F	■	4	688.80	975.34	698.88	985.42	1048.23	1406.80	1146.75	1554.72
30"(762mm)	60"(1524mm)	TCTP-3060-	■	S	F	■	4	\$694.14	\$ 949.94	\$705.06	\$ 960.86	\$1065.90	\$1384.70	\$1167.04	\$1529.04	
		TCTP-3066-	■	S	F	■	4	724.17	1002.48	737.19	1015.50	1160.99	1508.91	1279.53	1675.20	
		TCTP-3072-	■	S	F	■	4	754.38	1056.22	769.50	1071.34	1256.60	1634.98	1392.67	1823.53	
36"(914mm)	84"(2134mm)	TCTP-3684-	■	S	F	■	4	\$891.55	\$1259.88	\$916.75	\$1285.08	\$1691.72	\$2156.14	\$1906.81	\$2437.13	
Base — Power Ready — No Cutout																
29"(737mm)	24"(610mm)	48"(1219mm)	TCTP-2448-	■	S	F	■	4	\$610.37	\$ 810.99	\$613.73	\$ 814.35	\$ 756.84	\$1004.23	\$ 798.13	\$1077.59
		54"(1372mm)	TCTP-2454-	■	S	F	■	4	634.72	855.27	639.76	860.31	833.89	1107.09	889.32	1198.61
		60"(1524mm)	TCTP-2460-	■	S	F	■	4	659.24	900.76	665.96	907.48	911.48	1211.80	981.16	1321.80
		66"(1676mm)	TCTP-2466-	■	S	F	■	4	683.94	947.45	692.34	955.85	989.59	1318.37	1073.64	1447.17
		72"(1829mm)	TCTP-2472-	■	S	F	■	4	708.80	995.34	718.88	1005.42	1068.23	1426.80	1166.75	1574.72
30"(762mm)	60"(1524mm)	TCTP-3060-	■	S	F	■	4	\$714.14	\$ 969.94	\$725.06	\$ 980.86	\$1085.90	\$1404.70	\$1187.04	\$1549.04	
		TCTP-3066-	■	S	F	■	4	744.17	1022.48	757.19	1035.50	1180.99	1528.91	1299.53	1695.20	
		TCTP-3072-	■	S	F	■	4	774.38	1076.22	789.50	1091.34	1276.60	1654.98	1412.67	1843.53	
36"(914mm)	84"(2134mm)	TCTP-3684-	■	S	F	■	4	\$911.55	\$1279.88	\$936.75	\$1305.08	\$1711.72	\$2176.14	\$1926.81	\$2457.13	

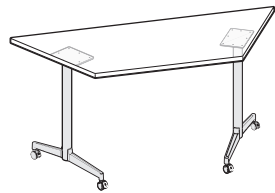

TCTP-SNF

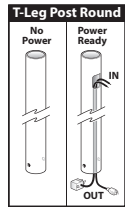

Features

- Includes 1-3/16"(30mm) thick top, two T-Leg bases with round columns, and hardware.
- Standard table height is 29"(737mm).
- Laminate top with knife edge or 3mm edgeband edges or wood veneer top with 3mm wood edgeband or knife edge.
- Casters:
 - Two locking and two non-locking casters with 5/8"(16mm) adjustment.
 - Standard in black.
- Glides:
 - 5/8"(16mm) adjustment.
 - Standard in black.
- Casters and glides are not interchangeable.
- Depth and width shown in nominal dimensions.
- Ships unassembled.

Specification Tips

- Edge choice allows a flat seam between tables.
- **Specifying a cutout does not automatically include a Power Ready base.**
- Factory installed cutout is available for:
 - Specify the (F) option for a Center, Single-Sided/4 outlet Flip Top Unit
 - Specify the (J) option for a Center, Single-Sided/6 outlet Flip Top Unit
- Power Ready Base:
 - Allows for cord management through one of the Round T-Legs. Powered leg location determined during installation.
 - Casters and Glides:
 - Specify the (J) option for Casters on the Power Ready base
 - Specify the (K) option for Glides on the Power Ready base
 - Flip Top Unit circuit breaker plug fits Power Ready Base opening.
- **Power cord length determines the distance to building power source.**
- Separately specified:
 - Ganging Mechanism - Recommended for use with power between tables.
 - Horizontal and Vertical Wire Management
 - Power and Data Components
- Refer to Specification Guide:
 - Accessory placement and compatibility.
 - Seating capacities and leg locations.
 - Information on electrical components compatible with factory cut opening.
 - Power Ready base cable capacity.
- Application may require approval of local authority having jurisdiction (AHJ); ensure compliance before placing orders and installation.
- Refer to Specification Guide for accessory placement and compatibility.

To Order, Specify:

- 1) Product number, including:

① Surface Option:

- L** Laminate
- W** Wood

② Edge Option:

Laminate:

- J** Edgeband
- F** Knife

Wood:

- K** Edgeband
- U** Knife

③ Cutout:

- N** No Cutout
- F** Center, Single-Sided/4 outlets, add \$33.13 list
- J** Center, Single-Sided/6 outlets, add \$33.13 list

④ Base and Wire Management Option:

Base - No Power:

- C** Casters, add \$15.60 list (29" Height Only)
- G** Glides

Base - Power Ready:

- J** Casters, add \$15.60 list (29" Height Only)
- K** Glides

⑤ Base Finish Option:

- A** Painted
- B** Polished, add \$46.80 list

- 2) Laminate surface color or wood finish color.
- 3) Edgeband trim color (laminate only).
- 4) Base trim color.

Note: \$41.60 upcharge list for Metallic trim colors.

Jive Table — T-Leg (Round or Extruded) — Flip Base

Rectangle – Laminate or Wood

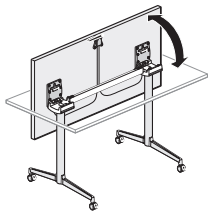
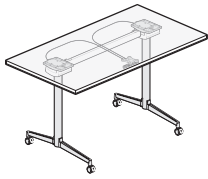

TCRA-SNFH4

Features

- Includes 1-3/16"(30mm) thick top, two T-Leg bases with round or extruded columns, stretcher and hardware.
- Standard table height is 29"(737mm).
- Laminate or wood top with 3mm edgeband on user edge and 1mm edgeband on remaining sides, or knife edge on user edge and 1mm edgeband on sides and back.
- T-Leg base with round columns are available with casters only.
- T-Leg base with extruded columns are available with casters and glides.
- Casters:
 - Two locking and two non-locking casters with 5/8"(16mm) adjustment.
 - Standard in black.
- Glides:
 - 5/8"(16mm) adjustment.
 - Standard in black.
- Casters and glides are not interchangeable.
- Depth and width shown in nominal dimensions.
- Ships unassembled.

Specification Tips

- Edge choice allows a flat seam between tables.
- **Specifying a cutout does not automatically include a Power Ready base.**
- Factory installed cutout is available for:
 - Specify the (A) option for a Center, Single-Sided/2 outlet Flip Top Unit
 - Specify the (F) option for a Center, Single-Sided/4 outlet Flip Top Unit
 - Specify the (J) option for a Center, Single-Sided/6 outlet Flip Top Unit
- Power Ready Base:
 - Allows for cord management through one of the T-Leg (Round or Extruded) Base Legs. Powered leg location determined during installation.
 - Casters and Glides:
 - Specify the (L) option for Casters on the Power Ready base
 - Specify the (M) option for Glides on the Power Ready base
 - Flip Top Unit circuit breaker plug fits Power Ready Base opening.
- **Power cord length determines the distance to building power source.**
- Separately specified:
 - Ganging Mechanism - Recommended for use with power between tables.
 - Horizontal and Vertical Wire Management
 - Power and Data Components
 - Accessories
- Refer to Specification Guide:
 - Accessory placement and compatibility.
 - Seating capacities and leg locations.
 - Information on electrical components compatible with factory cut opening.
 - Power Ready base cable capacity.
- Application may require approval of local authority having jurisdiction (AHJ); ensure compliance before placing orders and installation.

To Order, Specify:

- 1) Product number, including:

1 Surface Option:

- L** Laminate
- W** Wood

2 Edge Option:

Laminate:

- J** Edgeband
- F** Knife

Wood:

- K** Edgeband
- U** Knife

3 Cutout:

- N** No Cutout
- A** Center, Single-Sided/2 outlets, add **\$33.13** list
- F** Center, Single-Sided/4 outlets, add **\$33.13** list
- J** Center, Single-Sided/6 outlets, add **\$33.13** list

4 Base and Wire Management Option:

Base - No Power:

- H** Casters, add **\$15.60** list
- F** Glides

Base - Power Ready:

- L** Casters, add **\$15.60** list
- M** Glides

5 Base Finish Option:

- A** Painted
- B** Polished, add **\$46.80** list

- 2) Surface color.
- 3) Edge trim color.
- 4) Base trim color.

Note: **\$41.60** upcharge list for Metallic trim colors.

Jive Table — T-Leg (Round or Extruded) — Flip Base

Rectangle – Laminate or Wood

Height	Depth	Width	Number						Laminate A		Laminate B		Wood Group A		Wood Group B	
				①	②	③	④	⑤	J	F	J	F	K	U	K	U
Round — Base — No Power — No Cutout																
29"(737mm)	18"(457mm)	48"(1219mm)	TCRA-1848-	■	S	F	4	\$1003.38	\$1190.75	\$1074.90	\$1262.27	\$1486.34	\$1716.59	\$1592.55	\$1852.19	
		60"(1524mm)	TCRA-1860-	■	S	F	4	1041.58	1268.82	1115.62	1342.86	1607.04	1888.88	1735.54	2054.82	
		72"(1829mm)	TCRA-1872-	■	S	F	4	1080.47	1351.69	1157.03	1428.25	1729.85	2068.60	1881.09	2266.16	
24"(610mm)	48"(1219mm)	48"(1219mm)	TCRA-2448-	■	S	F	4	\$1047.61	\$1248.23	\$1122.49	\$1323.11	\$1626.82	\$1874.21	\$1758.39	\$2037.85	
		60"(1524mm)	TCRA-2460-	■	S	F	4	1096.48	1338.00	1174.72	1416.24	1781.46	2081.78	1941.42	2282.06	
		72"(1829mm)	TCRA-2472-	■	S	F	4	1146.04	1432.58	1227.64	1514.18	1938.21	2296.78	2127.01	2534.98	
30"(762mm)	48"(1219mm)	48"(1219mm)	TCRA-3048-	■	S	F	4	\$1091.83	\$1305.71	\$1170.07	\$1383.95	\$1767.29	\$2031.83	\$1924.23	\$2223.52	
		60"(1524mm)	TCRA-3060-	■	S	F	4	1151.38	1407.18	1233.82	1489.62	1955.88	2274.68	2147.30	2509.30	
		72"(1829mm)	TCRA-3072-	■	S	F	4	1211.62	1513.46	1298.26	1600.10	2146.58	2524.96	2372.93	2803.79	
36"(914mm)	60"(1524mm)	60"(1524mm)	TCRA-3660-	■	S	F	4	\$1206.28	\$1476.36	\$1292.92	\$1563.00	\$2130.30	\$2467.58	\$2353.18	\$2736.54	
		72"(1829mm)	TCRA-3672-	■	S	F	4	1277.19	1594.34	1368.87	1686.02	2354.95	2753.14	2618.85	3072.61	
Extruded — Base — No Power — No Cutout																
29"(737mm)	18"(457mm)	48"(1219mm)	TCRA-1848-	■	S	T	4	\$1142.24	\$1329.61	\$1213.76	\$1401.13	\$1625.20	\$1855.45	\$1731.41	\$1991.05	
		60"(1524mm)	TCRA-1860-	■	S	T	4	1180.44	1407.68	1254.48	1481.72	1745.90	2027.74	1874.40	2193.68	
		72"(1829mm)	TCRA-1872-	■	S	T	4	1219.33	1490.55	1295.89	1567.11	1868.71	2207.46	2019.95	2405.02	
24"(610mm)	48"(1219mm)	48"(1219mm)	TCRA-2448-	■	S	T	4	\$1186.47	\$1387.09	\$1261.35	\$1461.97	\$1765.68	\$2013.07	\$1897.25	\$2176.71	
		60"(1524mm)	TCRA-2460-	■	S	T	4	1235.34	1476.86	1313.58	1555.10	1920.32	2220.64	2080.28	2420.92	
		72"(1829mm)	TCRA-2472-	■	S	T	4	1284.90	1571.44	1366.50	1653.04	2077.07	2435.64	2265.87	2673.84	
30"(762mm)	48"(1219mm)	48"(1219mm)	TCRA-3048-	■	S	T	4	\$1230.69	\$1444.57	\$1308.93	\$1522.81	\$1906.15	\$2170.69	\$2063.09	\$2362.38	
		60"(1524mm)	TCRA-3060-	■	S	T	4	1290.24	1546.04	1372.68	1628.48	2094.74	2413.54	2286.16	2648.16	
		72"(1829mm)	TCRA-3072-	■	S	T	4	1350.48	1652.32	1437.12	1738.96	2285.44	2663.82	2511.79	2942.65	
36"(914mm)	60"(1524mm)	60"(1524mm)	TCRA-3660-	■	S	T	4	\$1345.14	\$1615.22	\$1431.78	\$1701.86	\$2269.16	\$2606.44	\$2492.04	\$2875.40	
		72"(1829mm)	TCRA-3672-	■	S	T	4	1416.05	1733.20	1507.73	1824.88	2493.81	2892.00	2757.71	3211.47	
Round — Base — Power Ready — No Cutout																
29"(737mm)	18"(457mm)	48"(1219mm)	TCRA-1848-	■	S	F	4	\$1023.38	\$1210.75	\$1094.90	\$1282.27	\$1506.34	\$1736.59	\$1612.55	\$1872.19	
		60"(1524mm)	TCRA-1860-	■	S	F	4	1061.58	1288.82	1135.62	1362.86	1627.04	1908.88	1755.54	2074.82	
		72"(1829mm)	TCRA-1872-	■	S	F	4	1100.47	1371.69	1177.03	1448.25	1749.85	2088.60	1901.09	2286.16	
24"(610mm)	48"(1219mm)	48"(1219mm)	TCRA-2448-	■	S	F	4	\$1067.61	\$1268.23	\$1142.49	\$1343.11	\$1646.82	\$1894.21	\$1778.39	\$2057.85	
		60"(1524mm)	TCRA-2460-	■	S	F	4	1116.48	1358.00	1194.72	1436.24	1801.46	2101.78	1961.42	2302.06	
		72"(1829mm)	TCRA-2472-	■	S	F	4	1166.04	1452.58	1247.64	1534.18	1958.21	2316.78	2147.01	2554.98	
30"(762mm)	48"(1219mm)	48"(1219mm)	TCRA-3048-	■	S	F	4	\$1111.83	\$1325.71	\$1190.07	\$1403.95	\$1787.29	\$2051.83	\$1944.23	\$2243.52	
		60"(1524mm)	TCRA-3060-	■	S	F	4	1171.38	1427.18	1253.82	1509.62	1975.88	2294.68	2167.30	2529.30	
		72"(1829mm)	TCRA-3072-	■	S	F	4	1231.62	1533.46	1318.26	1620.10	2166.58	2544.96	2392.93	2823.79	
36"(914mm)	60"(1524mm)	60"(1524mm)	TCRA-3660-	■	S	F	4	\$1226.28	\$1496.36	\$1312.92	\$1583.00	\$2150.30	\$2487.58	\$2373.18	\$2756.54	
		72"(1829mm)	TCRA-3672-	■	S	F	4	1297.19	1614.34	1388.87	1706.02	2374.95	2773.14	2638.85	3092.61	
Extruded — Base — Power Ready — No Cutout																
29"(737mm)	18"(457mm)	48"(1219mm)	TCRA-1848-	■	S	T	4	\$1162.24	\$1349.61	\$1233.76	\$1421.13	\$1645.20	\$1875.45	\$1751.41	\$2011.05	
		60"(1524mm)	TCRA-1860-	■	S	T	4	1200.44	1427.68	1274.48	1501.72	1765.90	2047.74	1894.40	2213.68	
		72"(1829mm)	TCRA-1872-	■	S	T	4	1239.33	1510.55	1315.89	1587.11	1888.71	2227.46	2039.95	2425.02	
24"(610mm)	48"(1219mm)	48"(1219mm)	TCRA-2448-	■	S	T	4	\$1206.47	\$1407.09	\$1281.35	\$1481.97	\$1785.68	\$2033.07	\$1917.25	\$2196.71	
		60"(1524mm)	TCRA-2460-	■	S	T	4	1255.34	1496.86	1333.58	1575.10	1940.32	2240.64	2100.28	2440.92	
		72"(1829mm)	TCRA-2472-	■	S	T	4	1304.90	1591.44	1386.50	1673.04	2097.07	2455.64	2285.87	2693.84	
30"(762mm)	48"(1219mm)	48"(1219mm)	TCRA-3048-	■	S	T	4	\$1250.69	\$1464.57	\$1328.93	\$1542.81	\$1926.15	\$2190.69	\$2083.09	\$2382.38	
		60"(1524mm)	TCRA-3060-	■	S	T	4	1310.24	1566.04	1392.68	1648.48	2114.74	2433.54	2306.16	2668.16	
		72"(1829mm)	TCRA-3072-	■	S	T	4	1370.48	1672.32	1457.12	1758.96	2305.44	2683.82	2531.79	2962.65	
36"(914mm)	60"(1524mm)	60"(1524mm)	TCRA-3660-	■	S	T	4	\$1365.14	\$1635.22	\$1451.78	\$1721.86	\$2289.16	\$2626.44	\$2512.04	\$2895.40	
		72"(1829mm)	TCRA-3672-	■	S	T	4	1436.05	1753.20	1527.73	1844.88	2513.81	2912.00	2777.71	3231.47	

Jive Table — Swivel Base

Square – Laminate or Wood

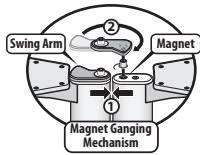
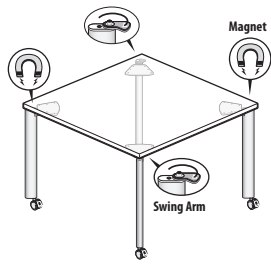

TVRQ-LJSNR

Depth	Width	Number	Laminate		Wood Group	
			A	B	A	B
24"(610mm)	24"(610mm)	TVRQ-2424- ■ ■ SNRG4	\$ 829.86	\$ 829.86	\$ 898.98	\$ 904.74
30"(762mm)	30"(762mm)	TVRQ-3030- ■ ■ SNR ■ 4	887.49	891.45	1064.16	1080.00
36"(914mm)	36"(914mm)	TVRQ-3636- ■ ■ SNR ■ 4	956.38	965.18	1260.66	1288.50
42"(1067mm)	42"(1067mm)	TVRQ-4242- ■ ■ SNR ■ 4	1036.53	1051.05	1488.48	1530.24
48"(1219mm)	48"(1219mm)	TVRQ-4848- ■ ■ SNR ■ 4	1127.94	1149.06	1747.62	1805.22

Features

- Includes 1 3/16"(30mm) top, leg bases with magnetic ganging mechanism, adjustable casters or glides and hardware.
- Standard table height is 29"(737mm).
- Laminate top with 3mm edgeband or wood veneer top with 3mm wood edgeband.
- Top available in standard core only.
- Leg bases are painted aluminum.
- Casters have 1/2"(13mm) height adjustment.
- Glides have 3/4"(19mm) height adjustment.
- Grommets are available for field installation; separately specified.
- Depth and width shown in nominal dimensions.
- Ships unassembled.

Specification Tips

- 24"(610mm) depth tables not designed to support screens or monitors.
- Screen and Monitor Arm application (approved with casters or glides):
 - 30"(762mm)-48"(1219mm) deep table supports a 27"(686mm) high Belong screen or monitor(s) up to 25 lbs.
- **Power cord length determines the distance to building power source.**
- Separately specified:
 - Horizontal and Vertical Wire Management
 - See Accessories Price List for Power and Data Components
 - Accessories
- Refer to Specification Guide:
 - Accessory placement and compatibility.
 - Seating capacities and leg locations.
- Application may require approval of local authority having jurisdiction (AHJ); ensure compliance before placing orders and installation.

To Order, Specify:

- 1) Product number, including:

1 Surface Option:

- L Laminate
- W Wood

2 Edge Option:

- J Edgeband
- K Wood Edgeband

3 Base Style:

- C Casters, add \$16.22 list
- G Glides

- 2) Laminate surface color or wood surface color.
- 3) Edge trim color (laminated only).
- 4) Base trim color.

Note: \$43.26 upcharge list for Metallic trim colors.

Jive Table — Swivel Base

Rectangle – Laminate or Wood

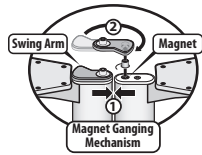
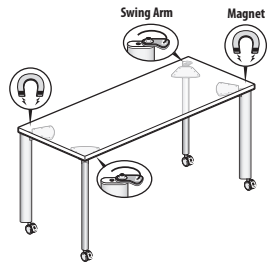

TCRA-LJSNR

Depth	Width	Number	①	②	③	Laminate		Wood Group		
						A	B	A	B	
18"(457mm)	48"(1219mm)	TCRA-1848-	■	■	SNR	4	\$ 750.94	\$ 818.77	\$1022.21	\$1069.46
	54"(1372mm)	TCRA-1854-	■	■	SNR	4	767.32	836.47	1074.89	1131.56
	60"(1524mm)	TCRA-1860-	■	■	SNR	4	783.70	854.17	1127.57	1193.66
	66"(1676mm)	TCRA-1866-	■	■	SNR	4	800.08	871.87	1180.25	1255.76
	72"(1829mm)	TCRA-1872-	■	■	SNR	4	816.46	889.57	1232.93	1317.86
24"(610mm)	36"(914mm)	TCRA-2436-	■	■	SNR	4	\$ 750.94	\$ 818.77	\$1022.21	\$1069.46
	42"(1067mm)	TCRA-2442-	■	■	SNR	4	772.78	842.37	1092.45	1152.26
	48"(1219mm)	TCRA-2448-	■	■	SNR	4	794.62	865.97	1162.69	1235.06
	54"(1372mm)	TCRA-2454-	■	■	SNR	4	816.46	889.57	1232.93	1317.86
	60"(1524mm)	TCRA-2460-	■	■	SNR	4	838.30	913.17	1303.17	1400.66
	66"(1676mm)	TCRA-2466-	■	■	SNR	4	860.14	936.77	1373.41	1483.46
30"(762mm)	36"(914mm)	TCRA-3036-	■	■	SNR	4	\$ 783.70	\$ 854.17	\$1127.57	\$1193.66
	42"(1067mm)	TCRA-3042-	■	■	SNR	4	811.00	883.67	1215.37	1297.16
	48"(1219mm)	TCRA-3048-	■	■	SNR	4	838.30	913.17	1303.17	1400.66
	54"(1372mm)	TCRA-3054-	■	■	SNR	4	865.60	942.67	1390.97	1504.16
	60"(1524mm)	TCRA-3060-	■	■	SNR	4	892.90	972.17	1478.77	1607.66
36"(914mm)	66"(1676mm)	TCRA-3066-	■	■	SNR	4	920.20	1001.67	1566.57	1711.16
	72"(1829mm)	TCRA-3072-	■	■	SNR	4	947.50	1031.17	1654.37	1814.66
	72"(1829mm)	TCRA-3072-	■	■	SNR	4	947.50	1031.17	1654.37	1814.66
	72"(1829mm)	TCRA-3072-	■	■	SNR	4	947.50	1031.17	1654.37	1814.66
	72"(1829mm)	TCRA-3072-	■	■	SNR	4	947.50	1031.17	1654.37	1814.66
36"(914mm)	66"(1676mm)	TCRA-3666-	■	■	SNR	4	\$ 980.26	\$1066.57	\$1759.73	\$1938.86
	72"(1829mm)	TCRA-3672-	■	■	SNR	4	1013.02	1101.97	1865.09	2063.06

Features

- Includes 1 3/16"(30mm) top, leg bases with magnetic ganging mechanism, adjustable casters or glides and hardware.
- Standard table height is 29"(737mm).
- Laminate top with 3mm edgeband or wood veneer top with 3mm wood edgeband.
- Top available in standard core only.
- Leg bases are painted aluminum.
- Casters have 1/2"(13mm) height adjustment.
- Glides have 3/4"(19mm) height adjustment.
- Grommets are available for field installation; separately specified.
- Depth and width shown in nominal dimensions.
- Ships unassembled.

Specification Tips

- 24"(610mm) depth tables not designed to support screens or monitors.
- Screen and Monitor Arm application (approved with casters or glides):
–30"(762mm)-48"(1219mm) deep table supports a 27"(686mm) high
Belong screen or monitor(s) up to 25 lbs.
- **Power cord length determines the distance to building power source.**
- Separately specified:
–Horizontal and Vertical Wire Management
–See Accessories Price List for Power and Data Components
–Accessories
- Refer to Specification Guide:
–Accessory placement and compatibility.
–Seating capacities and leg locations.
- Application may require approval of local authority having jurisdiction (AHJ); ensure compliance before placing orders and installation.

To Order, Specify:

- 1) Product number, including:

① Surface Option:

- L Laminate
- W Wood

② Edge Option:

- J Edgeband
- K Wood Edgeband

③ Base Style:

- C Casters, add \$16.22 list
- G Glides

- 2) Laminate surface color or wood surface color.
- 3) Edge trim color (laminated only).
- 4) Base trim color.

Note: \$43.26 upcharge list for Metallic trim colors.

Jive Table — Swivel Base

Trapezoid – Laminate or Wood

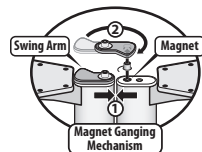
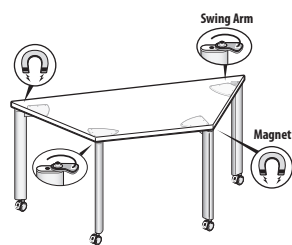

TVTP-LJSNR

Depth	Width	Number	①	②	③	Laminate		Wood Group			
						A	B	A	B		
24"(610mm)	48"(1219mm)	TVTP-2448-	■	■	SNR	■	4	\$ 887.94	\$ 891.38	\$1038.49	\$1082.08
	54"(1372mm)	TVTP-2454-	■	■	SNR	■	4	913.10	918.26	1118.40	1176.77
	60"(1524mm)	TVTP-2460-	■	■	SNR	■	4	938.44	945.32	1198.84	1272.12
	66"(1676mm)	TVTP-2466-	■	■	SNR	■	4	963.96	972.56	1279.82	1368.12
	72"(1829mm)	TVTP-2472-	■	■	SNR	■	4	989.66	999.98	1361.33	1464.79
30"(762mm)	60"(1524mm)	TVTP-3060-	■	■	SNR	■	4	\$ 995.06	\$1006.24	\$1380.08	\$1486.14
	66"(1676mm)	TVTP-3066-	■	■	SNR	■	4	1026.08	1039.41	1478.71	1602.96
	72"(1829mm)	TVTP-3072-	■	■	SNR	■	4	1057.28	1072.76	1577.87	1720.44

Features

- Includes 1 3/16"(30mm) top, 4 legs with magnetic ganging mechanism, adjustable casters or glides and hardware.
- Standard table height is 29"(737mm).
- Laminate top with 3mm edgeband or wood veneer top with 3mm wood edgeband.
- Top available in standard core only.
- Leg bases are painted aluminum.
- Casters have 1/2"(13mm) height adjustment.
- Glides have 3/4"(19mm) height adjustment.
- Grommets are available for field installation; separately specified.
- Depth and width shown in nominal dimensions.
- Ships unassembled.

Specification Tips

- Enhanced Power Module and Table Dome are available for field installation; separately specified.
- Magnetic field can be harmful to pacemaker wearers.**
- 24"(610mm) depth tables not designed to support screens or monitors.
- Screen and Monitor Arm application (with or without casters):
 - 30"(762mm)-48"(1219mm) deep table supports a 27"(686mm) high
 - Along screen or monitor(s) up to 25 lbs.
- Power cord length determines the distance to building power source.**
- Separately specified:
 - Horizontal and Vertical Wire Management
 - See Accessories Price List for Power and Data Components
 - Accessories
- Refer to Specification Guide:
 - Accessory placement and compatibility.
 - Seating capacities and leg locations.
- Application may require approval of local authority having jurisdiction (AHJ); ensure compliance before placing orders and installation.

To Order, Specify:

- Product number, including:

① Surface Option:

- L** Laminate
- W** Wood

② Edge Option:

- J** Edgeband
- K** Wood Edgeband

③ Base Style:

- C** Casters, add \$16.22 list
- G** Glides

- Laminate surface color or wood surface color.
- Edge trim color (laminated only).
- Base trim color.

Note: \$43.26 upcharge list for Metallic trim colors.

Jive Table — Swivel Base

Crescent – Laminate or Wood

Depth	Width	Number	① ② ③		Laminate		Wood Group	
			A	B	A	B		
24"(610mm)	60"(1524mm)	TVBN-2460-	SNR	4	\$1285.21	\$1292.25	\$1554.97	\$1631.85
30"(762mm)	72"(1829mm)	TVBN-3072-	SNR	4	1408.96	1424.80	1949.01	2098.09
36"(914mm)	84"(2134mm)	TVBN-3684-	SNR	4	1556.37	1582.77	2418.69	2653.67

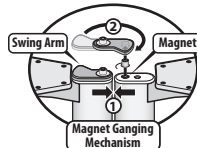
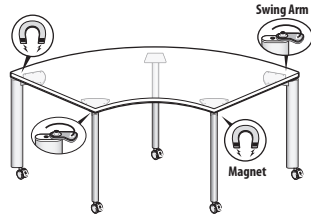

TVBN-LJSNR

Features

- Includes 1 3/16"(30mm) top, 4 legs with magnetic ganging mechanism, one post leg, adjustable casters or glides and hardware.
- Standard table height is 29"(737mm).
- Laminate top with 3mm edgeband or wood veneer top with 3mm wood edgeband.
- Top available in standard core only.
- Leg bases are painted aluminum.
- Casters have 1/2"(13mm) height adjustment.
- Glides have 3/4"(19mm) height adjustment.
- Grommets are available for field installation; separately specified.
- Depth and width shown in nominal dimensions.
- Ships unassembled.

Specification Tips

- Enhanced Power Module and Table Dome are available for field installation; separately specified.
- **Magnetic field can be harmful to pacemaker wearers.**
- 24"(610mm) depth tables not designed to support screens or monitors.
- Screen and Monitor Arm application (with or without casters):
 - 30"(762mm)-48"(1219mm) deep table supports a 27"(686mm) high
 - Long screen or monitor(s) up to 25 lbs.
- **Power cord length determines the distance to building power source.**
- Separately specified:
 - Horizontal and Vertical Wire Management
 - See Accessories Price List for Power and Data Components
 - Accessories
- Refer to Specification Guide:
 - Accessory placement and compatibility.
 - Seating capacities and leg locations.
- Application may require approval of local authority having jurisdiction (AHJ); ensure compliance before placing orders and installation.

To Order, Specify:

1) Product number, including:

① Surface Option:

- L Laminate
- W Wood

② Edge Option:

- J Edgeband
- K Wood Edgeband

③ Base Style:

- C Casters, add \$16.22 list
- G Glides

- 2) Laminate surface color or wood surface color.
- 3) Edge trim color (laminated only).
- 4) Base trim color.

Note: \$43.26 upcharge list for Metallic trim colors.

Jive Table — Swivel Base

Corner, Transitional Extended – Laminate or Wood

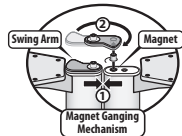
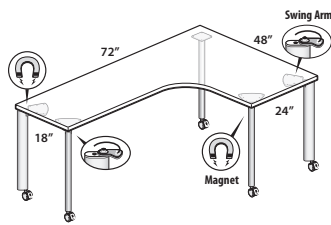

TVCX-LJSNRP

Left/Right Depth	Width	Length	Number	①	②	③	Laminate A	Laminate B	Wood Group A	Wood Group B
Left-Hand										
18"(457mm)/24"(610mm)	42"(1067mm)	60"(1524mm)	TVCX-4260-	■	■	SNR P	\$1199.13	\$1206.93	\$1545.93	\$1632.93
		72"(1829mm)	TVCX-4272-	■	■	SNR P	1350.09	1369.33	2259.61	2474.21
Right-Hand										
24"(610mm)/18"(457mm)	42"(1067mm)	60"(1524mm)	TVCX-4260-	■	■	SNR U	\$1203.33	\$1211.13	\$1545.93	\$1632.93
		72"(1829mm)	TVCX-4272-	■	■	SNR U	1354.49	1373.73	2259.61	2474.21
Left-Hand										
24"(610mm)/30"(762mm)	48"(1219mm)	60"(1524mm)	TVCX-4860-	■	■	SNR R	\$1199.53	\$1207.33	\$1545.93	\$1632.93
		72"(1829mm)	TVCX-4872-	■	■	SNR R	1350.69	1369.93	2259.61	2474.21
Right-Hand										
30"(762mm)/24"(610mm)	48"(1219mm)	60"(1524mm)	TVCX-4860-	■	■	SNR W	\$1203.93	\$1211.73	\$1545.93	\$1632.93
		72"(1829mm)	TVCX-4872-	■	■	SNR W	1354.89	1374.13	2259.61	2474.21

Features

- Includes 1 3/16"(30mm) top, adjustable casters or glides and hardware:
 - Legs:
 - 24"(610mm)/18"(457mm) depth - 2 legs with magnetic ganging mechanisms and 3 post legs
 - 24"(610mm)/30"(762mm) depth - 4 legs with magnetic ganging mechanisms and 1 post leg
 - 18"(457mm) depth always has the post leg
 - 24"(610mm) and 30"(762mm) depth always has the magnetic ganging mechanism
 - Standard table height is 29"(737mm).
 - Laminate top with 3mm edgeband or wood veneer top with 3mm wood edgeband.
 - Top available in standard core only.
 - Leg bases are painted aluminum.
 - Casters have 1/2"(13mm) height adjustment.
 - Glides have 3/4"(19mm) height adjustment.
 - Grommets are available for field installation; separately specified.
 - Depth and width shown in nominal dimensions.
 - Ships unassembled.

Specification Tips

- Enhanced Power Module and Table Dome are available for field installation; separately specified.
- Magnetic field can be harmful to pacemaker wearers.**
- 24"(610mm) depth tables not designed to support screens or monitors.
- Screen and Monitor Arm application (with or without casters):
 - 30"(762mm)-48"(1219mm) deep table supports a 27"(686mm) high
 - Belong screen or monitor(s) up to 25 lbs.
- Power cord length determines the distance to building power source.**
- Separately specified:
 - Horizontal and Vertical Wire Management
 - See Accessories Price List for Power and Data Components
 - Accessories
- Refer to Specification Guide:
 - Accessory placement and compatibility.
 - Seating capacities and leg locations.
- Application may require approval of local authority having jurisdiction (AHJ); ensure compliance before placing orders and installation.

To Order, Specify:

- Product number, including:

① Surface Option:

- L Laminate
- W Wood

② Edge Option:

- J Edgeband
- K Wood Edgeband

③ Base Style:

- C Casters, add \$16.22 list
- G Glides

- Laminate surface color or wood surface color.
- Edge trim color (laminated only).
- Base trim color.

Note: \$43.26 upcharge list for Metallic trim colors.

Jive Table — Swivel Base

Corner, Extended – Laminate or Wood

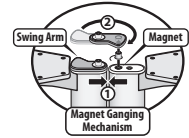
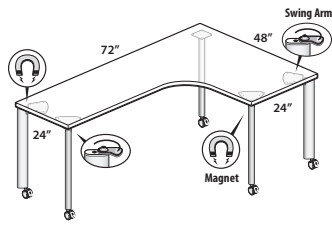

TVCE-LJSNRE

Left/Right Depth	Width	Length	Number	①	②	③	Laminate A	Laminate B	Wood Group A	Wood Group B
Left-Hand										
24"(610mm)/24"(610mm)	42"(1067mm)	60"(1524mm)	TVCE-4260-	■	■	SNR	E	\$1201.53	\$1209.33	\$1545.93 \$1632.93
		72"(1829mm)	TVCE-4272-	■	■	SNR	E	1352.49	1371.73	2259.61 2474.21
24"(610mm)/24"(610mm)	48"(1219mm)	60"(1524mm)	TVCE-4860-	■	■	SNR	E	\$1201.53	\$1209.33	\$1545.93 \$1632.93
		72"(1829mm)	TVCE-4872-	■	■	SNR	E	1352.49	1371.73	2259.61 2474.21
Right-Hand										
24"(610mm)/24"(610mm)	42"(1067mm)	60"(1524mm)	TVCE-4260-	■	■	SNR	H	\$1201.53	\$1209.33	\$1545.93 \$1632.93
		72"(1829mm)	TVCE-4272-	■	■	SNR	H	1352.49	1371.73	2259.61 2474.21
24"(610mm)/24"(610mm)	48"(1219mm)	60"(1524mm)	TVCE-4860-	■	■	SNR	H	\$1201.53	\$1209.33	\$1545.93 \$1632.93
		72"(1829mm)	TVCE-4872-	■	■	SNR	H	1352.49	1371.73	2259.61 2474.21
Left-Hand										
30"(762mm)/30"(762mm)	48"(1219mm)	60"(1524mm)	TVCE-4860-	■	■	SNR	F	\$1201.93	\$1209.73	\$1545.93 \$1632.93
		72"(1829mm)	TVCE-4872-	■	■	SNR	F	1353.09	1372.33	2259.61 2474.21
Right-Hand										
30"(762mm)/30"(762mm)	48"(1219mm)	60"(1524mm)	TVCE-4860-	■	■	SNR	J	\$1201.93	\$1209.73	\$1545.93 \$1632.93
		72"(1829mm)	TVCE-4872-	■	■	SNR	J	1353.09	1372.33	2259.61 2474.21

Features

- Includes 1 3/16"(30mm) top, 4 legs with magnetic ganging mechanism, one post leg, adjustable casters or glides and hardware.
- Standard table height is 29"(737mm).
- Laminate top with 3mm edgeband or wood veneer top with 3mm wood edgeband.
- Top available in standard core only.
- Leg bases are painted aluminum.
- Casters have 1/2"(13mm) height adjustment.
- Glides have 3/4"(19mm) height adjustment.
- Grommets are available for field installation; separately specified.
- Depth and width shown in nominal dimensions.
- Ships unassembled.

Specification Tips

- Enhanced Power Module and Table Dome are available for field installation; separately specified.
- **Magnetic field can be harmful to pacemaker wearers.**
- 24"(610mm) depth tables not designed to support screens or monitors.
- Screen and Monitor Arm application (with or without casters):
 - 30"(762mm)-48"(1219mm) deep table supports a 27"(686mm) high
 - Long screen or monitor(s) up to 25 lbs.
- **Power cord length determines the distance to building power source.**
- Separately specified:
 - Horizontal and Vertical Wire Management
 - See Accessories Price List for Power and Data Components
 - Accessories
- Refer to Specification Guide:
 - Accessory placement and compatibility.
 - Seating capacities and leg locations.
- Application may require approval of local authority having jurisdiction (AHJ); ensure compliance before placing orders and installation.

To Order, Specify:

1) Product number, including:

① Surface Option:

- L** Laminate
- W** Wood

② Edge Option:

- J** Edgeband
- K** Wood Edgeband

③ Base Style:

- C** Casters, add \$16.22 list
- G** Glides

- 2) Laminate surface color or wood surface color.
- 3) Edge trim color (laminated only).
- 4) Base trim color.

Note: \$43.26 upcharge list for Metallic trim colors.

Master Series

This page intentionally blank

Master Series Table — (Round or Square)

Tables

Table — Round

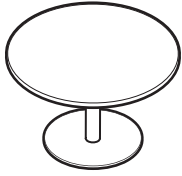

XZAM-1S

Height	Diameter	Number ①	Laminate A	B	Wood Group A	Group B
Laminate						
29 1/4"(743mm)	30"(762mm)	XLAM-3000-JS	\$1531.12	\$1596.74	N/A	N/A
	36"(914mm)	XLAM-3600-JS	1681.90	1744.66	N/A	N/A
	42"(1067mm)	XLAM-4200-JS	1859.30	1918.68	N/A	N/A
	48"(1219mm)	XLAM-4800-JS	2063.32	2118.80	N/A	N/A
Wood						
29 1/4"(743mm)	30"(762mm)	XZAM-3000- S	N/A	N/A	\$1624.18	\$1731.92
	36"(914mm)	XZAM-3600- S	N/A	N/A	1835.46	1955.53
	42"(1067mm)	XZAM-4200- S	N/A	N/A	2080.94	2215.34
	48"(1219mm)	XZAM-4800- S	N/A	N/A	2360.62	2511.35

Features

- Includes round top and 27"(686mm) disc base.
- 30"(762mm) and 36"(914mm) includes 21"(533mm) disc base.
- 42"(1067mm) and 48"(1219mm) includes 27"(686mm) disc base.
- Fixed height base: 29 1/4"(743mm).
- 1 3/16"(30mm) thick laminate worksurface with T-mold edgeband.
- 1 3/16"(30mm) thick wood worksurface with a choice of profiled edge (Square, Bevel, Radius or Traditional). Double-cut veneers available with Square 3mm Radius edge only.

To Order, Specify:

- 1) Product number, including:

① Edge Option:

Wood:

- | | |
|---|--------------------------------|
| 1 | Square |
| 5 | Bevel, add \$210.43 list |
| 6 | Radius, add \$210.43 list |
| 7 | Traditional, add \$210.43 list |

- 2) Finish code (laminate or wood).
- 3) Laminate edge trim color (if laminate specified).
- 4) Trim code for disc base.

Note: \$16.38 upcharge (list) for metallic or accent trim colors.

Height	Depth	Width	Number ①	Laminate A	B	Wood Group A	Wood Group B
Laminate							
29 1/4"(743mm)	30"(762mm)	30"(762mm)	XLAS-3030-JS	\$1631.69	\$1701.64	N/A	N/A
	36"(914mm)	36"(914mm)	XLAS-3636-JS	1792.34	1859.32	N/A	N/A
	42"(1067mm)	42"(1067mm)	XLAS-4242-JS	1981.37	2044.84	N/A	N/A
Wood							
29 1/4"(743mm)	30"(762mm)	30"(762mm)	XZAS-3030- S	N/A	N/A	\$1950.35	\$2071.25
	36"(914mm)	36"(914mm)	XZAS-3636- S	N/A	N/A	2207.42	2343.31
	42"(1067mm)	42"(1067mm)	XZAS-4242- S	N/A	N/A	2498.69	2651.57

Square Tables

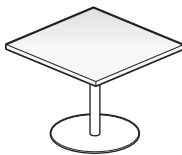
XLAS-3030
XZAS-3030

Features

- Includes square top and 27"(686mm) disc base.
- Includes 1 3/16"(36mm) thick laminate worksurface with 3mm edgeband.
- Includes 1 3/16"(36mm) thick wood worksurface with a choice of profiled edge (Square, Bevel, Radius or Traditional). **Double-cut veneers available with Square 3mm edge only.**

To Order, Specify:

- 1) Product number, including:

① Edge Option:

Wood:

- | | |
|---|--------------------------------|
| 1 | Square |
| 5 | Bevel, add \$210.43 list |
| 6 | Radius, add \$210.43 list |
| 7 | Traditional, add \$210.43 list |

- 2) Finish code (laminate or wood).
- 3) Laminate edge trim color (if laminate specified).
- 4) Trim code for disc base.

Note: \$16.38 upcharge (list) for Metallic and accent trim colors.

This page intentionally blank

Pip

This page intentionally blank

Pip At-A-Glance

General Specifications

Personal Laptop Table

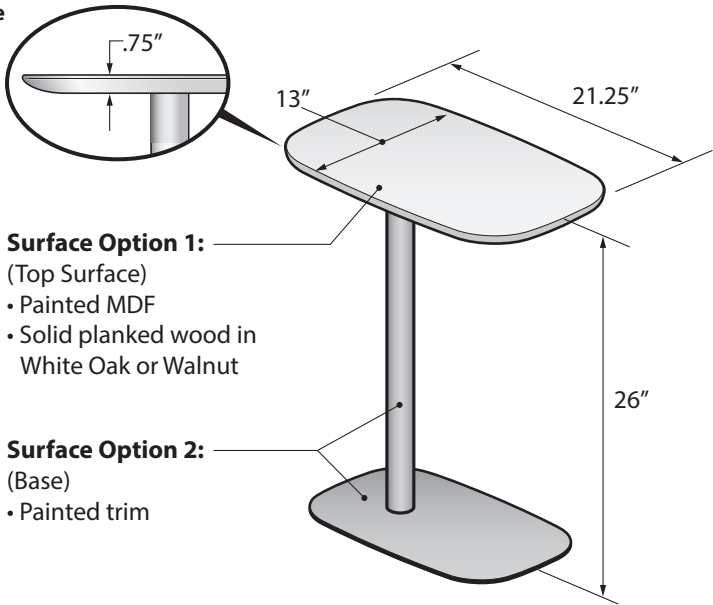

- Surface Option 1:**
 (Top Surface)
 • Painted MDF
 • Solid planked wood in White Oak or Walnut

- Surface Option 2:**
 (Base)
 • Painted trim

General Guidelines for Product Specification

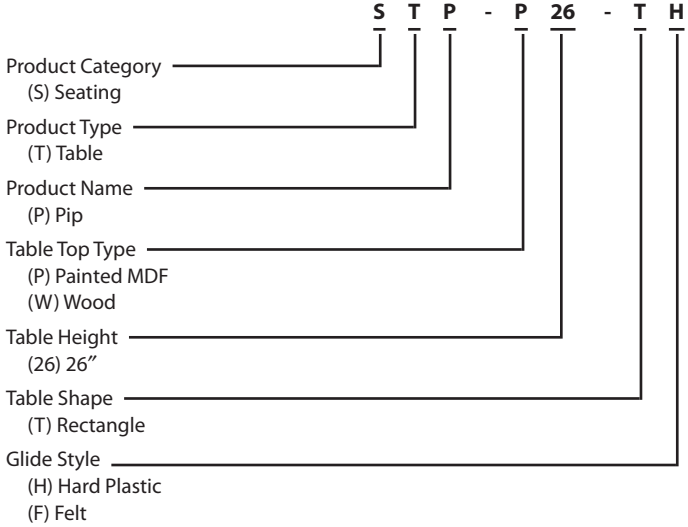

Pip

Personal Laptop Table



STP-P26-TH

Height	Depth	Width	Number ① ②	Painted MDF	White Oak	Walnut
26"(660mm)	13"(330mm)	21.25"(540mm)	STP-■ 26-T ■	\$591.56	\$1075.06	\$1208.74

Features

- Includes table top, base and hardware.
- Top available in painted MDF or planked wood in White Oak or Walnut.
- Wood tops are designed to be unique using solid wood planks with a clear, low-gloss finish showing natural variation.
- Base: Painted aluminum support plate and column with painted steel base plate.
- Ships unassembled.

To Order, Specify:

1) Product number, including:

① Surface Material:

- P** Painted MDF
- W** Planked Wood

② Glide Type:

- H** Hard Plastic
- F** Felt

2) Top surface and color.

3) Base trim color.

Planes

This page intentionally blank

Planes Collaborative Tables — Rectangular — Laminate

Y-Leg Flip Top or Non-Flip Top Table

Depth	Width	Laminate Number ① ② ③	Laminate A		Laminate B	
			J	F	J	F
Flip Top Tables						
30"(762mm)	60"(1524mm)	TARA-3060-L S Y 4	\$1256.00	\$1470.20	\$1324.83	\$1539.03
	66"(1676mm)	TARA-3066-L S Y 4	1318.71	1547.19	1394.34	1622.82
	72"(1829mm)	TARA-3072-L S Y 4	1381.42	1624.18	1463.85	1706.61
36"(914mm)	60"(1524mm)	TARA-3660-L S Y 4	\$1378.66	\$1607.14	\$1461.09	\$1689.57
	66"(1676mm)	TARA-3666-L S Y 4	1453.36	1696.12	1543.95	1786.71
	72"(1829mm)	TARA-3672-L S Y 4	1528.06	1785.10	1626.81	1883.85
Non-Flip Top Tables						
30"(762mm)	60"(1524mm)	TARA-3060-L S Y 4	\$1256.00	\$1470.20	\$1324.83	\$1539.03
	66"(1676mm)	TARA-3066-L S Y 4	1318.71	1547.19	1394.34	1622.82
	72"(1829mm)	TARA-3072-L S Y 4	1381.42	1624.18	1463.85	1706.61
36"(914mm)	60"(1524mm)	TARA-3660-L S Y 4	\$1378.66	\$1607.14	\$1461.09	\$1689.57
	66"(1676mm)	TARA-3666-L S Y 4	1453.36	1696.12	1543.95	1786.71
	72"(1829mm)	TARA-3672-L S Y 4	1528.06	1785.10	1626.81	1883.85
	78"(1981mm)	TARA-3678-L S Y 4	1602.76	1874.08	1709.67	1980.99
	84"(2134mm)	TARA-3684-L S Y 4	1677.46	1963.06	1792.53	2078.13
	90"(2286mm)	TARA-3690-L S Y 4	1752.16	2052.04	1875.39	2175.27
	96"(2438mm)	TARA-3696-L S Y 4	1826.86	2141.02	1958.25	2272.41

Flip Top Table

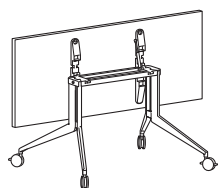

Non-Flip Top Table



TARA

Features

- Includes 1 3/16"(30mm) thick top, two Y-leg assemblies, stretcher and hardware.
- Standard table height is 29"(737mm) with 27 7/8"(708mm) knee clearance.
- Laminate top with knife edge or 3mm edgeband edges or wood veneer top with 3mm wood edgeband or knife edge.
- Base Options:
 - Flip Top Table with casters (H) or with glides (F).
 - Non-flip Top Table with casters (C) or with glides (G).
- Flip Top Table:
 - Table top flips from horizontal to vertical position via pneumatic assist mechanism activated by two finger pulls.
 - Tables nest when flipped to vertical position. Refer to Specification Guide for details.
- Base and stretcher are painted aluminum.
- Stretcher provides lay-in cable management.
- Optional Flip top unit electrical modules are separately specified. Refer to electrical components for appropriate product specification.
- Optional casters (two locking) or glides are field interchangeable.
- Casters have light platinum hub with graphite tread.
- Glides are light platinum with 1/2"(13mm) height adjustment.
- Depth and width shown in nominal dimensions.
- Ships unassembled.

Specification Tips

- 3mm edgeband edge is recommended to allow a flat seam between tables.
- The following Planes products are separately specified:
 - Ganging clip
 - Flip top unit electrical modules
 - Grommets (field cut opening)
 - Vertical wire management
 - Y-leg Bumper

To Order, Specify:

- 1) Product number, including:

① Edge Option:

- J** Edgeband
- F** Knife

② Flip Top Unit Cutout(s):

- N** None
- F** Center – single-sided/4 outlets, add \$33.13 list
- J** Center – single-sided/6 outlets, add \$33.13 list

③ Base Option (Flip/Non-Flip):

- H** Flip Top Table – Casters, add \$334.78 list
- F** Flip Top Table – Glides, add \$412.78 list
- C** Non-flip Top Table: Casters
- G** Non-flip Top Table: Glides, add \$78.00 list

- 2) Laminate surface color.
- 3) Edge trim color.
- 4) Base/Stretcher trim color.

Note: \$45.78 upcharge list for Metallic and accent trim colors.

Planes Collaborative Tables — Pebble — Laminate

Y-Leg Flip Top or Non-Flip Top Table

Depth	Width	Number ① ② ③	Laminate A		Laminate B	
			J	F	J	F
Flip Top Tables						
30"(762mm)	60"(1524mm)	TARP-3060-L S Y 4	\$1268.60	\$1491.80	\$1337.43	\$1560.63
	66"(1676mm)	TARP-3066-L S Y 4	1332.15	1570.23	1407.78	1645.86
	72"(1829mm)	TARP-3072-L S Y 4	1395.70	1648.66	1478.13	1731.09
36"(914mm)	60"(1524mm)	TARP-3660-L S Y 4	\$1392.10	\$1630.18	\$1474.53	\$1712.61
	66"(1676mm)	TARP-3666-L S Y 4	1467.64	1720.60	1558.23	1811.19
	72"(1829mm)	TARP-3672-L S Y 4	1543.18	1811.02	1641.93	1909.77
Non-Flip Top Tables						
30"(762mm)	60"(1524mm)	TARP-3060-L S Y 4	\$1268.60	\$1491.80	\$1337.43	\$1560.63
	66"(1676mm)	TARP-3066-L S Y 4	1332.15	1570.23	1407.78	1645.86
	72"(1829mm)	TARP-3072-L S Y 4	1395.70	1648.66	1478.13	1731.09
36"(914mm)	60"(1524mm)	TARP-3660-L S Y 4	\$1392.10	\$1630.18	\$1474.53	\$1712.61
	66"(1676mm)	TARP-3666-L S Y 4	1467.64	1720.60	1558.23	1811.19
	72"(1829mm)	TARP-3672-L S Y 4	1543.18	1811.02	1641.93	1909.77
	78"(1981mm)	TARP-3678-L S Y 4	1618.72	1901.44	1725.63	2008.35
	84"(2134mm)	TARP-3684-L S Y 4	1694.26	1991.86	1809.33	2106.93
	90"(2286mm)	TARP-3690-L S Y 4	1769.80	2082.28	1893.03	2205.51
	96"(2438mm)	TARP-3696-L S Y 4	1845.34	2172.70	1976.73	2304.09

Flip Top Table

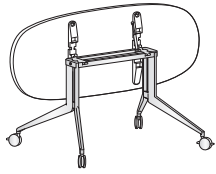

Non-Flip Top Table



TARP

Features

- Includes 1 3/16"(30mm) thick top, two Y-leg assemblies, stretcher and hardware.
- Standard table height is 29"(737mm) with 27 7/8"(708mm) knee clearance.
- Laminate top with knife edge or 3mm edgeband edges or wood veneer top with 3mm wood edgeband or knife edge.
- Base Options:
 - Flip Top Table with casters (H) or with glides (F).
 - Non-flip Top Table with casters (C) or with glides (G).
- Flip Top Table:
 - Table top flips from horizontal to vertical position via pneumatic assist mechanism activated by two finger pulls.
 - Tables nest when flipped to vertical position. Refer to Specification Guide for details.
- Base and stretcher are painted aluminum.
- Stretcher provides lay-in cable management.
- Optional Flip top unit electrical modules are separately specified. Refer to electrical components for appropriate product specification.
- Optional casters (two locking) or glides are field interchangeable.
- Casters have light platinum hub with graphite tread.
- Glides are light platinum with 1/2"(13mm) height adjustment.
- Depth and width shown in nominal dimensions.
- Ships unassembled.

Specification Tips

- The following Planes products are separately specified:
 - Ganging clip
 - Flip top unit electrical modules
 - Grommets (field cut opening)
 - Vertical wire management
 - Y-leg Bumper

To Order, Specify:

- 1) Product number, including:

① Edge Option:

- J** Edgeband
- F** Knife

② Flip Top Unit Cutout(s):

- N** None
- F** Center – single sided/4 outlets, add \$33.13 list
- J** Center – single-sided/6 outlets, add \$33.13 list

③ Base Option (Flip/Non-Flip):

- H** Flip Top Table – Casters, add \$334.78 list
- F** Flip Top Table – Glides, add \$412.78 list
- C** Non-flip Top Table: Casters
- G** Non-flip Top Table: Glides, add \$78.00 list

- 2) Laminate surface color.
- 3) Edge trim color.
- 4) Base/Stretcher trim color.

Note: \$45.78 upcharge list for Metallic and accent trim colors.

Planes Collaborative Tables — Hexagon — Laminate

Y-Leg Flip Top or Non-Flip Top Table

Depth	Width	Number ① ② ③	Laminate A		Laminate B	
			J	F	J	F
Flip Top Tables						
30"(762mm)	60"(1524mm)	TARX-3060-L █ S █ Y █ 4	\$1268.60	\$1491.80	\$1337.43	\$1560.63
	66"(1676mm)	TARX-3066-L █ S █ Y █ 4	1332.15	1570.23	1407.78	1645.86
	72"(1829mm)	TARX-3072-L █ S █ Y █ 4	1395.70	1648.66	1478.13	1731.09
36"(914mm)	60"(1524mm)	TARX-3660-L █ S █ Y █ 4	\$1392.10	\$1630.18	\$1474.53	\$1712.61
	66"(1676mm)	TARX-3666-L █ S █ Y █ 4	1467.64	1720.60	1558.23	1811.19
	72"(1829mm)	TARX-3672-L █ S █ Y █ 4	1543.18	1811.02	1641.93	1909.77
Non-Flip Top Tables						
30"(762mm)	60"(1524mm)	TARX-3060-L █ S █ Y █ 4	\$1268.60	\$1491.80	\$1337.43	\$1560.63
	66"(1676mm)	TARX-3066-L █ S █ Y █ 4	1332.15	1570.23	1407.78	1645.86
	72"(1829mm)	TARX-3072-L █ S █ Y █ 4	1395.70	1648.66	1478.13	1731.09
36"(914mm)	60"(1524mm)	TARX-3660-L █ S █ Y █ 4	\$1392.10	\$1630.18	\$1474.53	\$1712.61
	66"(1676mm)	TARX-3666-L █ S █ Y █ 4	1467.64	1720.60	1558.23	1811.19
	72"(1829mm)	TARX-3672-L █ S █ Y █ 4	1543.18	1811.02	1641.93	1909.77
	78"(1981mm)	TARX-3678-L █ S █ Y █ 4	1618.72	1901.44	1725.63	2008.35
	84"(2134mm)	TARX-3684-L █ S █ Y █ 4	1694.26	1991.86	1809.33	2106.93
	90"(2286mm)	TARX-3690-L █ S █ Y █ 4	1769.80	2082.28	1893.03	2205.51
	96"(2438mm)	TARX-3696-L █ S █ Y █ 4	1845.34	2172.70	1976.73	2304.09

Flip Top Table

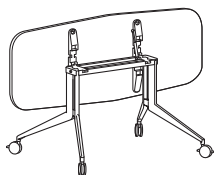

Non-Flip Top Table

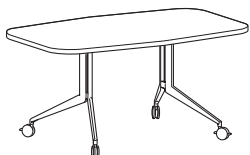

TARX

Features

- Includes 1 3/16"(30mm) thick top, two Y-leg assemblies, stretcher and hardware.
- Standard table height is 29"(737mm) with 27 7/8"(708mm) knee clearance.
- Laminate top with knife edge or 3mm edgeband edges or wood veneer top with 3mm wood edgeband or knife edge.
- Base Options:
 - Flip Top Table with casters (H) or with glides (F).
 - Non-flip Top Table with casters (C) or with glides (G).
- Flip Top Table:
 - Table top flips from horizontal to vertical position via pneumatic assist mechanism activated by two finger pulls.
 - Tables nest when flipped to vertical position. Refer to Specification Guide for details.
- Base and stretcher are painted aluminum.
- Stretcher provides lay-in cable management
- Optional Flip top unit electrical modules are separately specified. Refer to electrical components for appropriate product specification.
- Optional casters (two locking) or glides are field interchangeable.
- Casters have light platinum hub with graphite tread.
- Glides are light platinum with 1/2"(13mm) height adjustment.
- Depth and width shown in nominal dimensions.
- Ships unassembled.

Specification Tips

- The following Planes products are separately specified:
 - Ganging clip
 - Flip top unit electrical modules
 - Grommets (field cut opening)
 - Vertical wire management
 - Y-leg Bumper

To Order, Specify:

- 1) Product number, including:

① Edge Option:

- J** Edgeband
- F** Knife

② Flip Top Unit Cutout(s):

- N** None
- F** Center – single-sided/4 outlets, add \$33.13 list
- J** Center – single-sided/6 outlets, add \$33.13 list

③ Base Option (Flip/Non-Flip):

- H** Flip Top Table – Casters, add \$334.78 list
- F** Flip Top Table – Glides, add \$412.78 list
- C** Non-flip Top Table: Casters
- G** Non-flip Top Table: Glides, add \$78.00 list

- 2) Laminate surface color.
- 3) Edge trim color.
- 4) Base/Stretcher trim color.

Note: \$45.78 upcharge list for Metallic and accent trim colors.

Planes Collaborative Tables — Half Round — Laminate

Y-Leg Flip Top or Non-Flip Top Table

Depth	Width	Laminate Number	① ② ③			Laminate A		Laminate B	
			J	F	J	F	J	F	
Flip Top Table									
36"(914mm)	72"(1829mm)	TAHN-3672-L	S	Y	4	\$1513.15	\$1765.87	\$1610.11	\$1862.83
Non-Flip Top Table									
36"(914mm)	72"(1829mm)	TAHN-3672-L	S	Y	4	\$1513.15	\$1765.87	\$1610.11	\$1862.83

Flip Top Table

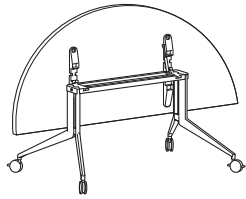

Non-Flip Top Table



TAHN

Features

- Includes 1 3/16"(30mm) thick top, two Y-leg assemblies, stretcher and hardware.
- Standard table height is 29"(737mm) with 27 7/8"(708mm) knee clearance.
- Laminate top with knife edge or 3mm edgeband edges or wood veneer top with 3mm wood edgeband or knife edge.
- Base Options:
 - Flip Top Table with casters (H) or with glides (F).
 - Non-flip Top Table with casters (C) or with glides (G).
- Flip Top Table:
 - Table top flips from horizontal to vertical position via pneumatic assist mechanism activated by two finger pulls.
 - Tables nest when flipped to vertical position. Refer to Specification Guide for details.
- Base and stretcher are painted aluminum.
- Stretcher provides lay-in cable management.
- Optional Flip top unit electrical modules are separately specified. Refer to electrical components for appropriate product specification.
- Optional casters (two locking) or glides are field interchangeable.
- Casters have light platinum hub with graphite tread.
- Glides are light platinum with 1/2"(13mm) height adjustment.
- Depth and width shown in nominal dimensions.
- Ships unassembled.

Specification Tips

- 3mm edgeband edge is recommended to allow a flat seam between tables.
- Width is meant to accommodate two 36"(914mm) tables.
- The following Planes products are separately specified:
 - Ganging clip
 - Flip top unit electrical modules
 - Grommets (field cut opening)
 - Vertical wire management
 - Y-leg Bumper

To Order, Specify:

1) Product number, including:

① Edge Option:

- J** Edgeband
- F** Knife

② Flip Top Unit Cutout(s):

- N** None
- F** Center – single-sided/4 outlets, add \$33.13 list
- J** Center – single-sided/6 outlets, add \$33.13 list

③ Base Option (Flip/Non-Flip):

- H** Flip Top Table – Casters, add \$334.78 list
- F** Flip Top Table – Glides, add \$412.78 list
- C** Non-flip Top Table: Casters
- G** Non-flip Top Table: Glides, add \$78.00 list

2) Laminate surface color.

3) Edge trim color.

4) Base/Stretcher trim color.

Note: \$45.78 upcharge list for Metallic and accent trim colors.

Planes Collaborative Tables — Polygon — Laminate

Y-Leg Flip Top or Non-Flip Top Table

Depth	Width	Laminate Number ① ② ③	Laminate A		Laminate B	
			J	F	J	F
Flip Top Tables						
30"(762mm)	60"(1524mm)	TACV-3060-L S Y 4	\$1250.10	\$1482.30	\$1319.92	\$1552.12
36"(914mm)	72"(1829mm)	TACV-3672-L S Y 4	1535.04	1869.41	1635.44	1969.81
Non-Flip Top Tables						
30"(762mm)	60"(1524mm)	TACV-3060-L S Y 4	\$1250.10	\$1482.30	\$1319.92	\$1552.12
36"(914mm)	72"(1829mm)	TACV-3672-L S Y 4	1535.04	1869.41	1635.44	1969.81

Flip Top Table

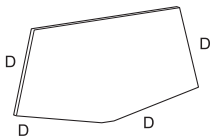
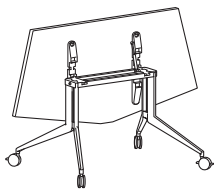

Features

- Includes 1 3/16"(30mm) thick top, two Y-leg assemblies, stretcher and hardware.
- Standard table height is 29"(737mm) with 27 7/8"(708mm) knee clearance.
- Laminate top with knife edge or 3mm edgeband edges or wood veneer top with 3mm wood edgeband or knife edge.
- Base Options:
 - Flip Top Table with casters (H) or with glides (F).
 - Non-flip Top Table with casters (C) or with glides (G).
- Flip Top Table:
 - Table top flips from horizontal to vertical position via pneumatic assist mechanism activated by two finger pulls.
 - Tables nest when flipped to vertical position. Refer to Specification Guide for details.
- Base and stretcher are painted aluminum.
- Stretcher provides lay-in cable management.
- Optional Flip top unit electrical modules are separately specified. Refer to electrical components for appropriate product specification.
- Optional casters (two locking) or glides are field interchangeable.
- Casters have light platinum hub with graphite tread.
- Glides are light platinum with 1/2"(13mm) height adjustment.
- Depth and width shown in nominal dimensions.
- Ships unassembled.

To Order, Specify:

- 1) Product number, including:

① Edge Option:

- J** Edgeband
- F** Knife

② Flip Top Unit Cutout(s):

- N** None
- F** Center – single-sided/4 outlets, add \$33.13 list
- J** Center – single-sided/6 outlets, add \$33.13 list

③ Base Option (Flip/Non-Flip):

- H** Flip Top Table – Casters, add \$334.78 list
- F** Flip Top Table – Glides, add \$412.78 list
- C** Non-flip Top Table: Casters
- G** Non-flip Top Table: Glides, add \$78.00 list

- 2) Laminate surface color.
- 3) Edge trim color.
- 4) Base/Stretcher trim color.

Note: \$45.78 upcharge list for Metallic and accent trim colors.

Non-Flip Top Table

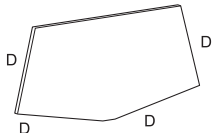

TACV

Specification Tips

- 3mm edgeband edge is recommended to allow a flat seam between tables.
- Depth matches 30"(762mm) or 36"(914mm) deep rectangular tables.
- The following Planes products are separately specified:
 - Ganging clip
 - Flip top unit electrical modules
 - Grommets (field cut opening)
 - Vertical wire management
 - Y-leg Bumper

Planes Collaborative Tables — Rectangular — Wood

Y-Leg Flip Top or Non-Flip Top Table

Depth	Width	Number	① ② ③			Wood Group A		Wood Group B	
			K	U		K	U		
Flip Top Tables									
30"(762mm)	60"(1524mm)	TARA-3060-W	S	Y	4	\$1620.09	\$1888.29	\$1644.15	\$1924.95
	66"(1676mm)	TARA-3066-W	S	Y	4	1723.85	2009.93	1752.89	2052.41
	72"(1829mm)	TARA-3072-W	S	Y	4	1827.61	2131.57	1861.63	2179.87
36"(914mm)	60"(1524mm)	TARA-3660-W	S	Y	4	\$1818.25	\$2104.33	\$1851.79	\$2151.31
	66"(1676mm)	TARA-3666-W	S	Y	4	1940.89	2244.85	1980.31	2298.55
	72"(1829mm)	TARA-3672-W	S	Y	4	2063.53	2385.37	2108.83	2445.79
Non-Flip Top Tables									
30"(762mm)	60"(1524mm)	TARA-3060-W	S	Y	4	\$1620.09	\$1888.29	\$1644.15	\$1924.95
	66"(1676mm)	TARA-3066-W	S	Y	4	1723.85	2009.93	1752.89	2052.41
	72"(1829mm)	TARA-3072-W	S	Y	4	1827.61	2131.57	1861.63	2179.87
36"(914mm)	60"(1524mm)	TARA-3660-W	S	Y	4	\$1818.25	\$2104.33	\$1851.79	\$2151.31
	66"(1676mm)	TARA-3666-W	S	Y	4	1940.89	2244.85	1980.31	2298.55
	72"(1829mm)	TARA-3672-W	S	Y	4	2063.53	2385.37	2108.83	2445.79
	78"(1981mm)	TARA-3678-W	S	Y	4	2186.17	2525.89	2237.35	2593.03
	84"(2134mm)	TARA-3684-W	S	Y	4	2308.81	2666.41	2365.87	2740.27
	90"(2286mm)	TARA-3690-W	S	Y	4	2431.45	2806.93	2494.39	2887.51
	96"(2438mm)	TARA-3696-W	S	Y	4	2554.09	2947.45	2622.91	3034.75

Flip Top Table

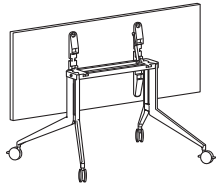

Non-Flip Top Table



TARA

Features

- Includes 1 3/16"(30mm) thick top, two Y-leg assemblies, stretcher and hardware.
- Standard table height is 29"(737mm) with 27 7/8"(708mm) knee clearance.
- Wood veneer top with 3mm wood edgeband or knife wood edges.
- Base Options:
 - Flip Top Table with casters (H) or with glides (F).
 - Non-flip Top Table with casters (C) or with glides (G).
- Flip Top Table:
 - Table top flips from horizontal to vertical position via pneumatic assist mechanism activated by two finger pulls.
 - Tables nest when flipped to vertical position. Refer to Specification Guide for details.
- Base and stretcher are painted aluminum.
- Stretcher provides lay-in cable management.
- Optional Flip top unit electrical modules are separately specified. Refer to electrical components for appropriate product specification.
- Optional casters (two locking) or glides are field interchangeable.
- Casters have light platinum hub with graphite tread.
- Glides are light platinum with 1/2"(13mm) height adjustment.
- Depth and width shown in nominal dimensions.
- Ships unassembled.

Specification Tips

- 3mm edgeband edge is recommended to allow a flat seam between tables; refer to Specification Guide.
- The following Planes products are separately specified:
 - Ganging clip
 - Flip top unit electrical modules
 - Grommets (field cut opening)
 - Vertical wire management
 - Y-leg Bumper

To Order, Specify:

1) Product number, including:

① Wood Edge Option:

- K** Edgeband
- U** Knife

② Flip Top Unit Cutout(s):

- N** None
- F** Center – single-sided/4 outlets, add \$33.13 list
- J** Center – single-sided/6 outlets, add \$33.13 list

③ Base Options (Flip/Non-Flip):

- H** Flip Top Table – Casters, add \$334.78 list
- F** Flip Top Table – Glides, add \$412.78 list
- C** Non-flip Top Table: Casters
- G** Non-flip Top Table: Glides, add \$78.00 list

2) Wood finish color.

3) Base/Stretcher trim color.

Note: \$45.78 upcharge (list) for Metallic and accent trim colors.

Planes Collaborative Tables — Pebble — Wood

Y-Leg Flip Top or Non-Flip Top Table

Depth	Width	Number ① ② ③	Wood Group A		Wood Group B	
			K	U	K	U
Flip Top Tables						
30"(762mm)	60"(1524mm)	TARP-3060-W █ S █ Y █ 4	\$1620.09	\$1888.29	\$1644.15	\$1924.95
	66"(1676mm)	TARP-3066-W █ S █ Y █ 4	1723.85	2009.93	1752.89	2052.41
	72"(1829mm)	TARP-3072-W █ S █ Y █ 4	1827.61	2131.57	1861.63	2179.87
36"(914mm)	60"(1524mm)	TARP-3660-W █ S █ Y █ 4	\$1818.25	\$2104.33	\$1851.79	\$2151.31
	66"(1676mm)	TARP-3666-W █ S █ Y █ 4	1940.89	2244.85	1980.31	2298.55
	72"(1829mm)	TARP-3672-W █ S █ Y █ 4	2063.53	2385.37	2108.83	2445.79
Non-Flip Top Tables						
30"(762mm)	60"(1524mm)	TARP-3060-W █ S █ Y █ 4	\$1620.09	\$1888.29	\$1644.15	\$1924.95
	66"(1676mm)	TARP-3066-W █ S █ Y █ 4	1723.85	2009.93	1752.89	2052.41
	72"(1829mm)	TARP-3072-W █ S █ Y █ 4	1827.61	2131.57	1861.63	2179.87
36"(914mm)	60"(1524mm)	TARP-3660-W █ S █ Y █ 4	\$1818.25	\$2104.33	\$1851.79	\$2151.31
	66"(1676mm)	TARP-3666-W █ S █ Y █ 4	1940.89	2244.85	1980.31	2298.55
	72"(1829mm)	TARP-3672-W █ S █ Y █ 4	2063.53	2385.37	2108.83	2445.79
	78"(1981mm)	TARP-3678-W █ S █ Y █ 4	2186.17	2525.89	2237.35	2593.03
	84"(2134mm)	TARP-3684-W █ S █ Y █ 4	2308.81	2666.41	2365.87	2740.27
	90"(2286mm)	TARP-3690-W █ S █ Y █ 4	2431.45	2806.93	2494.39	2887.51
	96"(2438mm)	TARP-3696-W █ S █ Y █ 4	2554.09	2947.45	2622.91	3034.75

Flip Top Table

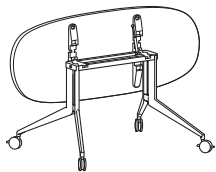

Non-Flip Top Table



TARP

Features

- Includes 1 3/16"(30mm) thick top, two Y-leg assemblies, stretcher and hardware.
- Standard table height is 29"(737mm) with 27 7/8"(708mm) knee clearance.
- Wood veneer top with 3mm wood edgeband or knife wood edges.
- Base Options:
 - Flip Top Table with casters (H) or with glides (F).
 - Non-flip Top Table with casters (C) or with glides (G).
- Flip Top Table:
 - Table top flips from horizontal to vertical position via pneumatic assist mechanism activated by two finger pulls.
 - Tables nest when flipped to vertical position. Refer to Specification Guide for details.
- Underside of table top has matching wood veneer surface.
- Base and stretcher are painted aluminum.
- Stretcher provides lay-in cable management.
- Optional Flip top unit electrical modules are separately specified. Refer to electrical components for appropriate product specification.
- Optional casters (two locking) or glides are field interchangeable.
- Casters have light platinum hub with graphite tread.
- Glides are light platinum with 1/2"(13mm) height adjustment.
- Depth and width shown in nominal dimensions.
- Ships unassembled.

Specification Tips

- The following Planes products are separately specified:
 - Ganging clip
 - Flip top unit electrical modules
 - Grommets (field cut opening)
 - Vertical wire management
 - Y-leg Bumper

To Order, Specify:

- 1) Product number, including:

① Wood Edge Option:

- K** Edgeband
- U** Knife

② Flip Top Unit Cutout(s):

- N** None
- F** Center – single-sided/4 outlets, add \$33.13 list
- J** Center – single-sided/6 outlets, add \$33.13 list

③ Base Options (Flip/Non-Flip):

- H** Flip Top Table – Casters, add \$334.78 list
- F** Flip Top Table – Glides, add \$412.78 list
- C** Non-flip Top Table: Casters
- G** Non-flip Top Table: Glides, add \$78.00 list

- 2) Wood finish color.
- 3) Base/Stretcher trim color.

Note: \$45.78 upcharge (list) for Metallic and accent trim colors.

Planes Collaborative Tables — Hexagon — Wood

Y-Leg Flip Top or Non-Flip Top Table

Depth	Width	Number ① ② ③	Wood Group A		Wood Group B	
			K	U	K	U
Flip Top Tables						
30"(762mm)	60"(1524mm)	TARX-3060-W █ S █ Y █ 4	\$1620.09	\$1888.29	\$1644.15	\$1924.95
	66"(1676mm)	TARX-3066-W █ S █ Y █ 4	1723.85	2009.93	1752.89	2052.41
	72"(1829mm)	TARX-3072-W █ S █ Y █ 4	1827.61	2131.57	1861.63	2179.87
36"(914mm)	60"(1524mm)	TARX-3660-W █ S █ Y █ 4	\$1818.25	\$2104.33	\$1851.79	\$2151.31
	66"(1676mm)	TARX-3666-W █ S █ Y █ 4	1940.89	2244.85	1980.31	2298.55
	72"(1829mm)	TARX-3672-W █ S █ Y █ 4	2063.53	2385.37	2108.83	2445.79
Non-Flip Top Tables						
30"(762mm)	60"(1524mm)	TARX-3060-W █ S █ Y █ 4	\$1620.09	\$1888.29	\$1644.15	\$1924.95
	66"(1676mm)	TARX-3066-W █ S █ Y █ 4	1723.85	2009.93	1752.89	2052.41
	72"(1829mm)	TARX-3072-W █ S █ Y █ 4	1827.61	2131.57	1861.63	2179.87
36"(914mm)	60"(1524mm)	TARX-3660-W █ S █ Y █ 4	\$1818.25	\$2104.33	\$1851.79	\$2151.31
	66"(1676mm)	TARX-3666-W █ S █ Y █ 4	1940.89	2244.85	1980.31	2298.55
	72"(1829mm)	TARX-3672-W █ S █ Y █ 4	2063.53	2385.37	2108.83	2445.79
	78"(1981mm)	TARX-3678-W █ S █ Y █ 4	2186.17	2525.89	2237.35	2593.03
	84"(2134mm)	TARX-3684-W █ S █ Y █ 4	2308.81	2666.41	2365.87	2740.27
	90"(2286mm)	TARX-3690-W █ S █ Y █ 4	2431.45	2806.93	2494.39	2887.51
	96"(2438mm)	TARX-3696-W █ S █ Y █ 4	2554.09	2947.45	2622.91	3034.75

Flip Top Table

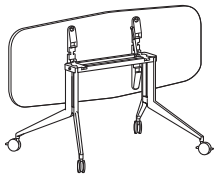

Non-Flip Top Table



TARX

Features

- Includes 1 3/16"(30mm) thick top, two Y-leg assemblies, stretcher and hardware.
- Standard table height is 29"(737mm) with 27 7/8"(708mm) knee clearance.
- Wood veneer top with 3mm wood edgeband or knife wood edges.
- Base Options:
 - Flip Top Table with casters (H) or with glides (F).
 - Non-flip Top Table with casters (C) or with glides (G).
- Flip Top Table:
 - Table top flips from horizontal to vertical position via pneumatic assist mechanism activated by two finger pulls.
 - Tables nest when flipped to vertical position. Refer to Specification Guide for details.
- Underside of table top has matching wood veneer surface.
- Base and stretcher are painted aluminum.
- Stretcher provides lay-in cable management.
- Optional Flip top unit electrical modules are separately specified. Refer to electrical components for appropriate product specification.
- Optional casters (two locking) or glides are field interchangeable.
- Casters have light platinum hub with graphite tread.
- Glides are light platinum with 1/2"(13mm) height adjustment.
- Depth and width shown in nominal dimensions.
- Ships unassembled.

Specification Tips

- The following Planes products are separately specified:
 - Ganging clip
 - Flip top unit electrical modules
 - Grommets (field cut opening)
 - Vertical wire management
 - Y-leg Bumper

To Order, Specify:

1) Product number, including:

① Wood Edge Option:

- K** Edgeband
- U** Knife

② Flip Top Unit Cutout(s):

- N** None
- F** Center – single-sided/4 outlets, add \$33.13 list
- J** Center – single-sided/6 outlets, add \$33.13 list

③ Base Options (Flip/Non-Flip):

- H** Flip Top Table – Casters, add \$334.78 list
- F** Flip Top Table – Glides, add \$412.78 list
- C** Non-flip Top Table: Casters
- G** Non-flip Top Table: Glides, add \$78.00 list

2) Wood finish color.

3) Base/Stretcher trim color.

Note: \$45.78 upcharge (list) for Metallic and accent trim colors.

Planes Collaborative Tables — Half Round — Wood

Y-Leg Flip Top or Non-Flip Top Table

Depth	Width	Number	Wood Group A		Wood Group B	
			1 2 3	K U	K U	
Flip Top Tables						
36"(914mm)	72"(1829mm)	TAHN-3672-W	S Y 4	\$2038.35	\$2353.71	\$2082.67 \$2413.15
Non-Flip Top Tables						
36"(914mm)	72"(1829mm)	TAHN-3672-W	S Y 4	\$2038.35	\$2353.71	\$2082.67 \$2413.15

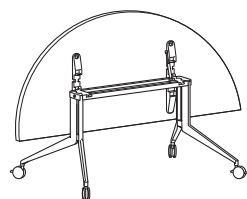
Flip Top Table**Non-Flip Top Table**

TAHN

Features

- Includes 1 3/16"(30mm) thick top, two Y-leg assemblies, stretcher and hardware.
- Standard table height is 29"(737mm) with 27 7/8"(708mm) knee clearance.
- Wood veneer top with 3mm wood edgeband or knife wood edges.
- Base Options:
 - Flip Top Table with casters (H) or with glides (F).
 - Non-flip Top Table with casters (C) or with glides (G).
- Flip Top Table:
 - Table top flips from horizontal to vertical position via pneumatic assist mechanism activated by two finger pulls.
 - Tables nest when flipped to vertical position. Refer to Specification Guide for details.
- Underside of table top has matching wood veneer surface.
- Base and stretcher are painted aluminum.
- Stretcher provides lay-in cable management.
- Optional Flip top unit electrical modules are separately specified. Refer to electrical components for appropriate product specification.
- Optional casters (two locking) or glides are field interchangeable.
- Casters have light platinum hub with graphite tread.
- Glides are light platinum with 1/2"(13mm) height adjustment.
- Depth and width shown in nominal dimensions.
- Ships unassembled.

Specification Tips

- 3mm edgeband edge is recommended to allow a flat seam between tables.
- Depth is meant to accommodate two 36"(914mm) deep rectangular tables.
- The following Planes products are separately specified:
 - Ganging clip
 - Grommets (field cut opening)
 - Flip top unit electrical modules
 - Vertical wire management
 - Y-leg Bumper

To Order, Specify:

1) Product number, including:

1 Edge Option:

- K** Edgeband
- U** Knife

2 Flip Top Unit Cutout(s):

- N** None
- F** Center – single-sided/4 outlets, add **\$33.13** list
- J** Center – single-sided/6 outlets, add **\$33.13** list

3 Base Options (Flip/Non-Flip):

- H** Flip Top Table – Casters, add **\$334.78** list
- F** Flip Top Table – Glides, add **\$412.78** list
- C** Non-flip Top Table: Casters
- G** Non-flip Top Table: Glides, add **\$78.00** list

2) Wood finish color.

3) Base/Stretcher trim color.

Note: **\$45.78** upcharge (list) for Metallic and accent trim colors.

Planes Collaborative Tables — Polygon — Wood

Y-Leg Flip Top or Non-Flip Top Table

Depth	Width	Number ① ② ③	Wood Group A		Wood Group B	
			K	U	K	U
Flip Top Tables						
30"(762mm)	60"(1524mm)	TACV-3060-W S Y 4	\$1654.36	\$1843.36	\$1683.18	\$1884.78
36"(914mm)	72"(1829mm)	TACV-3672-W S Y 4	2092.64	2364.80	2149.45	2439.75
Non-Flip Top Tables						
30"(762mm)	60"(1524mm)	TACV-3060-W S Y 4	\$1654.36	\$1843.36	\$1683.18	\$1884.78
36"(914mm)	72"(1829mm)	TACV-3672-W S Y 4	2092.64	2364.80	2149.45	2439.75

Flip Top Table

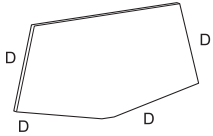
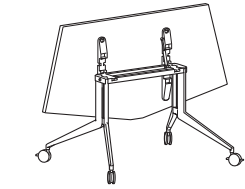

Non-Flip Top Table

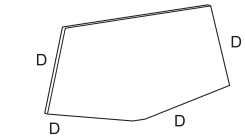

TACV

Features

- Includes 1 3/16"(30mm) thick top, two Y-leg assemblies, stretcher and hardware.
- Standard table height is 29"(737mm) with 27 7/8"(708mm) knee clearance.
- Wood veneer top with 3mm wood edgeband or knife wood edges.
- Base Options:
 - Flip Top Table with casters (H) or with glides (F).
 - Non-flip Top Table with casters (C) or with glides (G).
- Flip Top Table:
 - Table top flips from horizontal to vertical position via pneumatic assist mechanism activated by two finger pulls.
 - Tables nest when flipped to vertical position. Refer to Specification Guide for details.
- Underside of table top has matching wood veneer surface.
- Base and stretcher are painted aluminum.
- Stretcher provides lay-in cable management.
- Optional Flip top unit electrical modules are separately specified. Refer to electrical components for appropriate product specification.
- Optional casters (two locking) or glides are field interchangeable.
- Casters have light platinum hub with graphite tread.
- Glides are light platinum with 1/2"(13mm) height adjustment.
- Depth and width shown in nominal dimensions.
- Ships unassembled.

Specification Tips

- 3mm edgeband edge is recommended to allow a flat seam between tables.
- Depth is meant to accommodate 30"(762mm) or 36"(914mm) deep rectangular tables.
- The following Planes products are separately specified:
 - Ganging clip
 - Grommets (field cut opening)
 - Flip top unit electrical modules
 - Vertical cable management
 - Y-leg Bumper

To Order, Specify:

1) Product number, including:

① Edge Option:

- K** Edgeband
- U** Knife

② Flip Top Unit Cutout(s):

- N** None
- F** Center – single-sided/4 outlets, add \$33.13 list
- J** Center – single-sided/6 outlets, add \$33.13 list

③ Base Options (Flip/Non-Flip):

- H** Flip Top Table – Casters, add \$334.78 list
- F** Flip Top Table – Glides, add \$412.78 list
- C** Non-flip Top Table: Casters
- G** Non-flip Top Table: Glides, add \$78.00 list

2) Wood finish color.

3) Base/Stretcher trim color.

Note: \$45.78 upcharge (list) for Metallic and accent trim colors.

Planes Collaborative Tables — Accessories

	Width	Length	Number	Price
Vertical Wire Management	2"(51mm)	12"(305mm)	TA01-0212	\$44.58

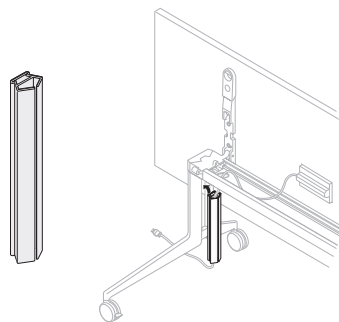

TA01-0212

Features

- Includes one plastic wire manager sleeve
- Standard in light platinum color
- Field installed

To Order, Specify:

- 1) Product number
(No color specification required.)

Specification Tips

- For use on the Y-leg assembly for flip top unit wire management
- Snaps into top portion of Y-leg assembly.

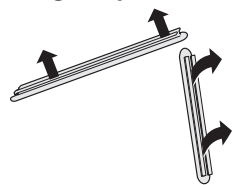
Y-Leg Bumper	Description	Number	Price
	For use on 36"(914mm) deep top	TA01-0213	\$8.61
	For use on 30"(762mm) deep top	TA01-0214	8.61

TA01-0213
TA01-0214**Feature**

- Includes 4 bumpers in light platinum.

To Order, Specify:

- 1) Product number
(No color specification required.)

Specification Tip

- Protects Y-leg tables when nested.

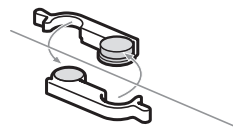
Ganging Mechanism	Number	Price
	TA01-0222	\$115.86

TA01-0222
(one set)**Features**

- Includes four (two sets) ganging mechanisms and attachment hardware.
- Standard in black.
- Ganging Mechanism required for in-line powered Planes C-Leg and Y-Leg Training Tables.
- Field installed.

To Order, Specify:

- 1) Product number.
(No finish specification required.)

Specification Tip

- Planes C-Leg Training Tables are drilled for ganging mechanisms.

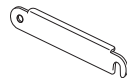
Ganging Clip	Number	Price
	TA01-0001	\$45.92

TA01-0001

Features

- Includes set of two ganging clips and installation hardware.
- Standard in black.

To Order, Specify:

- 1) Product number.
(No finish specification required.)

Planes Collaborative Tables — Accessories

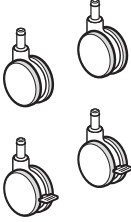
	Number	Price
<p>Casters</p>  <p>Hub Tread</p> <p>TA01-0216</p>	<p>TA01-0216</p> <p>Features</p> <ul style="list-style-type: none"> Includes 4 casters; 2 locking, 2 non-locking. –Casters are available with: Light platinum or fog hub with graphite tread, or black hub with black tread. <p>Specification Tip</p> <ul style="list-style-type: none"> Casters are for use with Y-leg tables, carts and easels. Not designed for interior or perimeter leg conference tables. 	<p>To Order, Specify:</p> <ol style="list-style-type: none"> Product number. Trim color for hub.

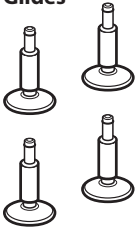
	Number	Price
<p>Glides</p>  <p>Stem Base Disc</p> <p>TA01-0215</p>	<p>Painted Stem</p> <p>TA01-0215</p> <p>Features</p> <ul style="list-style-type: none"> Includes 4 glides. Glides have 1/2" (13mm) height adjustment. Glides stems are either painted (specify paint trim color) or polished aluminum. Glide base disc is available in light platinum, fog or black (specify trim color). <p>Specification Tip</p> <ul style="list-style-type: none"> Glides are for use with Y-leg tables, carts and easels. Not designed for interior or perimeter leg conference tables. 	<p>To Order, Specify:</p> <ol style="list-style-type: none"> Product number. Stem trim color (for painted Glide). Base Disc trim color.

This page intentionally blank

Planes Tables — X Base

Laminate or Wood

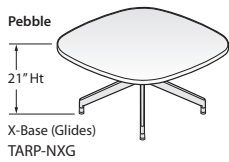
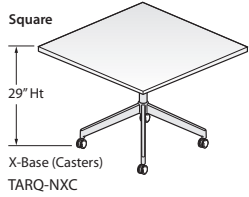
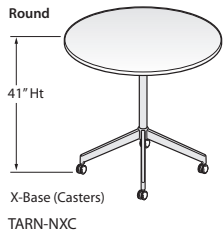

Features

- Laminate top with knife edge or 3mm edgeband edges or wood veneer top with 3mm wood edgeband or knife edge. Edgeband tops are 3mm on user edge and 1mm on remaining edges.
- Includes 1 3/16"(30mm) thick standard top, base and hardware.
- Fixed table height options are 29"(737mm) and 41"(1041mm).
- Caster and glides are not interchangeable.
- Casters (two locking/two non-locking) are available with: Light platinum or fog hub with graphite tread, or black hub with black tread.
- Glides are graphite and provide 1/2"(13mm) glide adjustment.
- Ships unassembled.

Specification Tips

- Base Sizes:
–30"(762mm) and 36"(914mm) tops include 27 1/4"(692mm) X-Base.
–42"(1067mm) and 48"(1219mm) tops include 33 3/4"(857mm) X-Base.

To Order, Specify:

1) Product number, including:

1 Surface Options:

- L** Laminate
- W** Wood

2 Edge Options:

Laminate:

- J** Edgeband
- F** Knife

Wood:

- K** Edgeband
- U** Knife

3 Base:

- C** Caster
- G** Glide, add **\$66.84** list

4 Base Material:

- A** Painted
- B** Polished, add **\$272.94** list

2) Laminate surface color or Wood finish color.

3) Edge trim color (laminate only).

4) Base trim color (painted only).

5) Caster color.

Note: **\$45.78** upcharge list for Metallic and accent trim colors.

Planes Tables — X Base

Laminate or Wood

Height	Depth	Width	Number ① ② ③ ④	Laminate A		Laminate B		Wood Group A		Wood Group B		
				J	F	J	F	K	U	K	U	
Round												
20"(508mm)	30"(762mm)	30"(762mm)	TARN-3030- SNX 2	\$ 682.42	\$ 872.82	\$ 748.26	\$ 938.66	\$1020.43	\$1212.63	\$1042.93	\$1251.69	
	36"(914mm)	36"(914mm)	TARN-3636- SNX 2	815.79	1035.95	896.04	1116.20	1215.04	1496.25	1249.43	1555.68	
	42"(1067mm)	42"(1067mm)	TARN-4242- SNX 2	972.10	1222.02	1069.38	1319.30	1440.67	1830.51	1488.85	1913.94	
	48"(1219mm)	48"(1219mm)	TARN-4848- SNX 2	1151.35	1431.03	1268.28	1547.96	1697.32	2215.94	1761.19	2327.03	
29"(737mm)	30"(762mm)	30"(762mm)	TARN-3030- SNX 4	\$ 699.13	\$ 889.53	\$ 764.97	\$ 955.37	\$1037.14	\$1229.34	\$1059.64	\$1268.40	
	36"(914mm)	36"(914mm)	TARN-3636- SNX 4	832.50	1052.66	912.75	1132.91	1231.75	1512.96	1266.14	1572.39	
	42"(1067mm)	42"(1067mm)	TARN-4242- SNX 4	988.81	1238.73	1086.09	1336.01	1457.38	1847.22	1505.56	1930.65	
	48"(1219mm)	48"(1219mm)	TARN-4848- SNX 4	1168.06	1447.74	1284.99	1564.67	1714.03	2232.65	1777.90	2343.74	
40"(1016mm)	30"(762mm)	30"(762mm)	TARN-3030- SNX 7	\$ 715.85	\$ 906.25	\$ 781.69	\$ 972.09	\$1053.86	\$1246.06	\$1076.36	\$1285.12	
	36"(914mm)	36"(914mm)	TARN-3636- SNX 7	849.22	1069.38	929.47	1149.63	1248.47	1529.68	1282.86	1589.11	
	42"(1067mm)	42"(1067mm)	TARN-4242- SNX 7	1005.53	1255.45	1102.81	1352.73	1474.10	1863.94	1522.28	1947.37	
	48"(1219mm)	48"(1219mm)	TARN-4848- SNX 7	1184.78	1464.46	1301.71	1581.39	1730.75	2249.37	1794.62	2360.46	
Square												
20"(508mm)	30"(762mm)	30"(762mm)	TARQ-3030- SNX 2	\$ 681.22	\$ 865.62	\$ 747.06	\$ 931.46	\$1020.43	\$1114.17	\$1042.93	\$1144.58	
	36"(914mm)	36"(914mm)	TARQ-3636- SNX 2	814.35	1027.31	894.60	1107.56	1215.04	1378.09	1249.43	1427.15	
	42"(1067mm)	42"(1067mm)	TARQ-4242- SNX 2	970.42	1211.94	1067.70	1309.22	1440.67	1693.11	1488.85	1764.47	
	48"(1219mm)	48"(1219mm)	TARQ-4848- SNX 2	1149.43	1419.51	1266.36	1536.44	1697.32	2058.39	1761.19	2155.65	
29"(737mm)	30"(762mm)	30"(762mm)	TARQ-3030- SNX 4	\$ 697.93	\$ 882.33	\$ 763.77	\$ 948.17	\$1037.14	\$1130.88	\$1059.64	\$1161.29	
	36"(914mm)	36"(914mm)	TARQ-3636- SNX 4	831.06	1044.02	911.31	1124.27	1231.75	1394.80	1266.14	1443.86	
	42"(1067mm)	42"(1067mm)	TARQ-4242- SNX 4	987.13	1228.65	1084.41	1325.93	1457.38	1709.82	1505.56	1781.18	
	48"(1219mm)	48"(1219mm)	TARQ-4848- SNX 4	1166.14	1436.22	1283.07	1553.15	1714.03	2075.10	1777.90	2172.36	
40"(1016mm)	30"(762mm)	30"(762mm)	TARQ-3030- SNX 7	\$ 714.65	\$ 899.05	\$ 780.49	\$ 964.89	\$1053.86	\$1147.60	\$1076.36	\$1178.01	
	36"(914mm)	36"(914mm)	TARQ-3636- SNX 7	847.78	1060.74	928.03	1140.99	1248.47	1411.52	1282.86	1460.58	
	42"(1067mm)	42"(1067mm)	TARQ-4242- SNX 7	1003.85	1245.37	1101.13	1342.65	1474.10	1726.54	1522.28	1797.90	
	48"(1219mm)	48"(1219mm)	TARQ-4848- SNX 7	1182.86	1452.94	1299.79	1569.87	1730.75	2091.82	1794.62	2189.08	
Pebble												
20"(508mm)	30"(762mm)	30"(762mm)	TARP-3030- SNX 2	\$ 681.22	\$ 865.62	\$ 747.06	\$ 931.46	\$1020.43	\$1114.17	\$1042.93	\$1144.58	
	36"(914mm)	36"(914mm)	TARP-3636- SNX 2	814.35	1027.31	894.60	1107.56	1215.04	1378.09	1249.43	1427.15	
	42"(1067mm)	42"(1067mm)	TARP-4242- SNX 2	970.42	1211.94	1067.70	1309.22	1440.67	1693.11	1488.85	1764.47	
	48"(1219mm)	48"(1219mm)	TARP-4848- SNX 2	1149.43	1419.51	1266.36	1536.44	1697.32	2058.39	1761.19	2155.65	
29"(737mm)	30"(762mm)	30"(762mm)	TARP-3030- SNX 4	\$ 697.93	\$ 882.33	\$ 763.77	\$ 948.17	\$1037.14	\$1130.88	\$1059.64	\$1161.29	
	36"(914mm)	36"(914mm)	TARP-3636- SNX 4	831.06	1044.02	911.31	1124.27	1231.75	1394.80	1266.14	1443.86	
	42"(1067mm)	42"(1067mm)	TARP-4242- SNX 4	987.13	1228.65	1084.41	1325.93	1457.38	1709.82	1505.56	1781.18	
	48"(1219mm)	48"(1219mm)	TARP-4848- SNX 4	1166.14	1436.22	1283.07	1553.15	1714.03	2075.10	1777.90	2172.36	
40"(1016mm)	30"(762mm)	30"(762mm)	TARP-3030- SNX 7	\$ 714.65	\$ 899.05	\$ 780.49	\$ 964.89	\$1053.86	\$1147.60	\$1076.36	\$1178.01	
	36"(914mm)	36"(914mm)	TARP-3636- SNX 7	847.78	1060.74	928.03	1140.99	1248.47	1411.52	1282.86	1460.58	
	42"(1067mm)	42"(1067mm)	TARP-4242- SNX 7	1003.85	1245.37	1101.13	1342.65	1474.10	1726.54	1522.28	1797.90	
	48"(1219mm)	48"(1219mm)	TARP-4848- SNX 7	1182.86	1452.94	1299.79	1569.87	1730.75	2091.82	1794.62	2189.08	

Planes Tables — Disc Base

Laminate or Wood

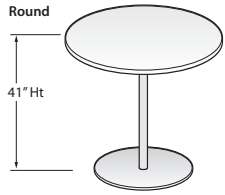

TARN-NDN

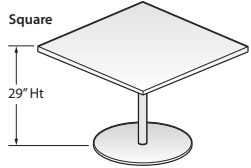

TARQ-NDN

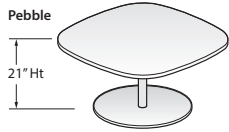

TARP-NDN

Features

- Laminate top with knife edge or 3mm edgeband edges or wood veneer top with 3mm wood edgeband or knife edge. Edgeband tops are 3mm on user edge and 1mm on remaining edges.
- Includes 1 3/16"(30mm) thick standard top, base and hardware.
- Fixed table height options are 29"(737mm) and 41"(1041mm).
- Ships unassembled.

Specification Tips

- Base Sizes:
 –30"(762mm) and 36"(914mm) tops include 21"(533mm) disc base.
 –42"(1067mm) and 48"(1219mm) tops include 27"(686mm) disc base.

To Order, Specify:

- 1) Product number, including:

① Surface Options:

- L** Laminate
- W** Wood

② Edge Options:

Laminate:

- J** Edgeband
- F** Knife

Wood:

- K** Edgeband
- U** Knife

- 2) Laminate surface color or Wood finish color.
- 3) Edge trim color (laminate only).
- 4) Base trim color.

Note: \$45.78 upcharge list for Metallic and accent trim colors.

Planes Tables — Disc Base

Laminate or Wood

Height	Depth	Width	Number ① ②	Laminate A		Laminate B		Wood Group A		Wood Group B		
				J	F	J	F	K	U	K	U	
Round												
20"(508mm)	30"(762mm)	30"(762mm)	TARN-3030- ■ ■ SNDN2A	\$ 861.78	\$1052.18	\$ 927.62	\$1118.02	\$1199.79	\$1391.99	\$1222.29	\$1431.05	
	36"(914mm)	36"(914mm)	TARN-3636- ■ ■ SNDN2A	995.15	1215.31	1075.40	1295.56	1394.40	1675.61	1428.79	1735.04	
	42"(1067mm)	42"(1067mm)	TARN-4242- ■ ■ SNDN2A	1151.46	1401.38	1248.74	1498.66	1620.03	2009.87	1668.21	2093.30	
	48"(1219mm)	48"(1219mm)	TARN-4848- ■ ■ SNDN2A	1330.71	1610.39	1447.64	1727.32	1876.68	2395.30	1940.55	2506.39	
29"(737mm)	30"(762mm)	30"(762mm)	TARN-3030- ■ ■ SNDN4A	\$ 878.49	\$1068.89	\$ 944.33	\$1134.73	\$1216.50	\$1408.70	\$1239.00	\$1447.76	
	36"(914mm)	36"(914mm)	TARN-3636- ■ ■ SNDN4A	1011.86	1232.02	1092.11	1312.27	1411.11	1692.32	1445.50	1751.75	
	42"(1067mm)	42"(1067mm)	TARN-4242- ■ ■ SNDN4A	1168.17	1418.09	1265.45	1515.37	1636.74	2026.58	1684.92	2110.01	
	48"(1219mm)	48"(1219mm)	TARN-4848- ■ ■ SNDN4A	1347.42	1627.10	1464.35	1744.03	1893.39	2412.01	1957.26	2523.10	
40"(1016mm)	30"(762mm)	30"(762mm)	TARN-3030- ■ ■ SNDN7A	\$ 895.21	\$1085.61	\$ 961.05	\$1151.45	\$1233.22	\$1425.42	\$1255.72	\$1464.48	
	36"(914mm)	36"(914mm)	TARN-3636- ■ ■ SNDN7A	1028.58	1248.74	1108.83	1328.99	1427.83	1709.04	1462.22	1768.47	
	42"(1067mm)	42"(1067mm)	TARN-4242- ■ ■ SNDN7A	1184.89	1434.81	1282.17	1532.09	1653.46	2043.30	1701.64	2126.73	
	48"(1219mm)	48"(1219mm)	TARN-4848- ■ ■ SNDN7A	1364.14	1643.82	1481.07	1760.75	1910.11	2428.73	1973.98	2539.82	
Square												
20"(508mm)	30"(762mm)	30"(762mm)	TARQ-3030- ■ ■ SNDN2A	\$ 859.69	\$1044.09	\$ 925.53	\$1109.93	\$1198.90	\$1292.64	\$1221.40	\$1323.05	
	36"(914mm)	36"(914mm)	TARQ-3636- ■ ■ SNDN2A	992.82	1205.78	1073.07	1286.03	1393.51	1556.56	1427.90	1605.62	
	42"(1067mm)	42"(1067mm)	TARQ-4242- ■ ■ SNDN2A	1148.89	1390.41	1246.17	1487.69	1619.14	1871.58	1667.32	1942.94	
	48"(1219mm)	48"(1219mm)	TARQ-4848- ■ ■ SNDN2A	1327.90	1597.98	1444.83	1714.91	1875.79	2236.86	1939.66	2334.12	
29"(737mm)	30"(762mm)	30"(762mm)	TARQ-3030- ■ ■ SNDN4A	\$ 876.40	\$1060.80	\$ 942.24	\$1126.64	\$1215.61	\$1309.35	\$1238.11	\$1339.76	
	36"(914mm)	36"(914mm)	TARQ-3636- ■ ■ SNDN4A	1009.53	1222.49	1089.78	1302.74	1410.22	1573.27	1444.61	1622.33	
	42"(1067mm)	42"(1067mm)	TARQ-4242- ■ ■ SNDN4A	1165.60	1407.12	1262.88	1504.40	1635.85	1888.29	1684.03	1959.65	
	48"(1219mm)	48"(1219mm)	TARQ-4848- ■ ■ SNDN4A	1344.61	1614.69	1461.54	1731.62	1892.50	2253.57	1956.37	2350.83	
40"(1016mm)	30"(762mm)	30"(762mm)	TARQ-3030- ■ ■ SNDN7A	\$ 893.12	\$1077.52	\$ 958.96	\$1143.36	\$1232.33	\$1326.07	\$1254.83	\$1356.48	
	36"(914mm)	36"(914mm)	TARQ-3636- ■ ■ SNDN7A	1026.25	1239.21	1106.50	1319.46	1426.94	1589.99	1461.33	1639.05	
	42"(1067mm)	42"(1067mm)	TARQ-4242- ■ ■ SNDN7A	1182.32	1423.84	1279.60	1521.12	1652.57	1905.01	1700.75	1976.37	
	48"(1219mm)	48"(1219mm)	TARQ-4848- ■ ■ SNDN7A	1361.33	1631.41	1478.26	1748.34	1909.22	2270.29	1973.09	2367.55	
Pebble												
20"(508mm)	30"(762mm)	30"(762mm)	TARP-3030- ■ ■ SNDN2A	\$ 860.58	\$1044.98	\$ 926.42	\$1110.82	\$1199.79	\$1293.53	\$1222.29	\$1323.94	
	36"(914mm)	36"(914mm)	TARP-3636- ■ ■ SNDN2A	993.71	1206.67	1073.96	1286.92	1394.40	1557.45	1428.79	1606.51	
	42"(1067mm)	42"(1067mm)	TARP-4242- ■ ■ SNDN2A	1149.78	1391.30	1247.06	1488.58	1620.03	1872.47	1668.21	1943.83	
	48"(1219mm)	48"(1219mm)	TARP-4848- ■ ■ SNDN2A	1328.79	1598.87	1445.72	1715.80	1876.68	2237.75	1940.55	2335.01	
29"(737mm)	30"(762mm)	30"(762mm)	TARP-3030- ■ ■ SNDN4A	\$ 877.29	\$1061.69	\$ 943.13	\$1127.53	\$1216.50	\$1310.24	\$1239.00	\$1340.65	
	36"(914mm)	36"(914mm)	TARP-3636- ■ ■ SNDN4A	1010.42	1223.38	1090.67	1303.63	1411.11	1574.16	1445.50	1623.22	
	42"(1067mm)	42"(1067mm)	TARP-4242- ■ ■ SNDN4A	1166.49	1408.01	1263.77	1505.29	1636.74	1889.18	1684.92	1960.54	
	48"(1219mm)	48"(1219mm)	TARP-4848- ■ ■ SNDN4A	1345.50	1615.58	1462.43	1732.51	1893.39	2254.46	1957.26	2351.72	
40"(1016mm)	30"(762mm)	30"(762mm)	TARP-3030- ■ ■ SNDN7A	\$ 894.01	\$1078.41	\$ 959.85	\$1144.25	\$1233.22	\$1326.96	\$1255.72	\$1357.37	
	36"(914mm)	36"(914mm)	TARP-3636- ■ ■ SNDN7A	1027.14	1240.10	1107.39	1320.35	1427.83	1590.88	1462.22	1639.94	
	42"(1067mm)	42"(1067mm)	TARP-4242- ■ ■ SNDN7A	1183.21	1424.73	1280.49	1522.01	1653.46	1905.90	1701.64	1977.26	
	48"(1219mm)	48"(1219mm)	TARP-4848- ■ ■ SNDN7A	1362.22	1632.30	1479.15	1749.23	1910.11	2271.18	1973.98	2368.44	

Planes Tables — Dual X Base

Laminate or Wood – Rectangle

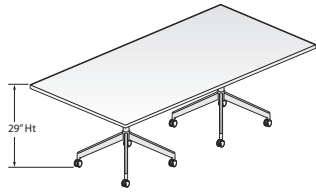

TARA-XC

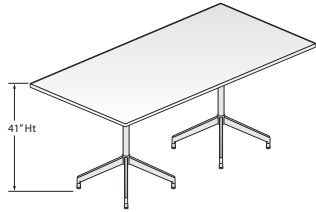

TARA-XG

Features

- Laminate top with knife edge or 3mm edgeband edges or wood veneer top with 3mm wood edgeband or knife edge. Edgeband tops are 3mm on user edge and 1mm on remaining edges.
- Includes 1 3/16"(30mm) thick standard top, bases and hardware.
- Fixed table height options are 29"(737mm) and 41"(1041mm).
- Casters (two locking/two non-locking) are available with: Light platinum or fog hub with graphite tread, or black hub with black tread.
- Glides available in graphite only and provide 1/2"(13mm) adjustment.
- Casters and glides are not interchangeable.
- Power modules are available for field installation; separately specified. Refer to Specification Guide.
- Ships unassembled.

Specification Tips

- Cutouts are designed for single sided flip top units and select workware connect interface modules (see workware price list).
- The following Planes products are separately specified:
 - Power modules
 - Grommet (field cut opening)
 - Wire Management

To Order, Specify:

1) Product number, including:

1 Surface Options:

- L** Laminate
- W** Wood

2 Edge Options:

Laminate:

- J** Edgeband
- F** Knife

Wood:

- K** Edgeband
- U** Knife

3 Cutout:

- N** No Cutout
- F** Center, Single-Sided/4 outlets, add **\$33.13** list
- J** Center, Single-Sided/6 outlets, add **\$33.13** list

4 Base:

- C** Caster
- G** Glide, add **\$133.68** list

5 Base Material:

- A** Painted
- B** Polished, add **\$545.88** list

- 2) Laminate surface color or wood finish color.
- 3) Edge trim color (laminated only).
- 4) Base trim color.

Note: **\$45.78** upcharge list for Metallic and accent trim colors.

Planes Tables — Dual X Base

Laminate or Wood – Rectangle

Height	Depth	Width	Number	① ② ③ ④ ⑤					Laminate A		Laminate B		Wood Group A		Wood Group B	
				J	F	J	F	K	U	K	U					
29"(737mm)	30"(762mm)	60"(1524mm)	TARA-3060-	S	X	4	\$1318.18	\$1573.98	\$1387.01	\$1642.81	\$1682.27	\$1992.07	\$1706.33	\$2028.73		
		66"(1676mm)	TARA-3066-	S	X	4	1380.89	1650.97	1456.52	1726.60	1786.03	2113.71	1815.07	2156.19		
		72"(1829mm)	TARA-3072-	S	X	4	1443.60	1727.96	1526.03	1810.39	1889.79	2235.35	1923.81	2283.65		
		78"(1981mm)	TARA-3078-	S	X	4	1506.31	1804.95	1595.54	1894.18	1993.55	2356.99	2032.55	2411.11		
		84"(2134mm)	TARA-3084-	S	X	4	1569.02	1881.94	1665.05	1977.97	2097.31	2478.63	2141.29	2538.57		
		90"(2286mm)	TARA-3090-	S	X	4	1631.73	1958.93	1734.56	2061.76	2201.07	2600.27	2250.03	2666.03		
		96"(2438mm)	TARA-3096-	S	X	4	1694.44	2035.92	1804.07	2145.55	2304.83	2721.91	2358.77	2793.49		
		36"(914mm)	60"(1524mm)	TARA-3660-	S	X	4	\$1440.84	\$1710.92	\$1523.27	\$1793.35	\$1880.43	\$2208.11	\$1913.97	\$2255.09	
			66"(1676mm)	TARA-3666-	S	X	4	1515.54	1799.90	1606.13	1890.49	2003.07	2348.63	2042.49	2402.33	
	72"(1829mm)		TARA-3672-	S	X	4	1590.24	1888.88	1688.99	1987.63	2125.71	2489.15	2171.01	2549.57		
	78"(1981mm)		TARA-3678-	S	X	4	1664.94	1977.86	1771.85	2084.77	2248.35	2629.67	2299.53	2696.81		
	84"(2134mm)		TARA-3684-	S	X	4	1739.64	2066.84	1854.71	2181.91	2370.99	2770.19	2428.05	2844.05		
	90"(2286mm)		TARA-3690-	S	X	4	1814.34	2155.82	1937.57	2279.05	2493.63	2910.71	2556.57	2991.29		
	96"(2438mm)		TARA-3696-	S	X	4	1889.04	2244.80	2020.43	2376.19	2616.27	3051.23	2685.09	3138.53		
	42"(1067mm)		60"(1524mm)	TARA-4260-	S	X	4	\$1563.50	\$1847.86	\$1659.53	\$1943.89	\$2078.59	\$2424.15	\$2121.61	\$2481.45	
			66"(1676mm)	TARA-4266-	S	X	4	1650.19	1948.83	1755.74	2054.38	2220.11	2583.55	2269.91	2648.47	
		72"(1829mm)	TARA-4272-	S	X	4	1736.88	2049.80	1851.95	2164.87	2361.63	2742.95	2418.21	2815.49		
		78"(1981mm)	TARA-4278-	S	X	4	1823.57	2150.77	1948.16	2275.36	2503.15	2902.35	2566.51	2982.51		
84"(2134mm)		TARA-4284-	S	X	4	1910.26	2251.74	2044.37	2385.85	2644.67	3061.75	2714.81	3149.53			
90"(2286mm)		TARA-4290-	S	X	4	1996.95	2352.71	2140.58	2496.34	2786.19	3221.15	2863.11	3316.55			
96"(2438mm)		TARA-4296-	S	X	4	2083.64	2453.68	2236.79	2606.83	2927.71	3380.55	3011.41	3483.57			
48"(1219mm)		60"(1524mm)	TARA-4860-	S	X	4	\$1686.16	\$1984.80	\$1795.79	\$2094.43	\$2276.75	\$2640.19	\$2329.25	\$2707.81		
		66"(1676mm)	TARA-4866-	S	X	4	1784.84	2097.76	1905.35	2218.27	2437.15	2818.47	2497.33	2894.61		
	72"(1829mm)	TARA-4872-	S	X	4	1883.52	2210.72	2014.91	2342.11	2597.55	2996.75	2665.41	3081.41			
	78"(1981mm)	TARA-4878-	S	X	4	1982.20	2323.68	2124.47	2465.95	2757.95	3175.03	2833.49	3268.21			
	84"(2134mm)	TARA-4884-	S	X	4	2080.88	2436.64	2234.03	2589.79	2918.35	3353.31	3001.57	3455.01			
	90"(2286mm)	TARA-4890-	S	X	4	2179.56	2549.60	2343.59	2713.63	3078.75	3531.59	3169.65	3641.81			
	96"(2438mm)	TARA-4896-	S	X	4	2278.24	2662.56	2453.15	2837.47	3239.15	3709.87	3337.73	3828.61			
	40"(1016mm)	30"(762mm)	60"(1524mm)	TARA-3060-	S	X	7	\$1385.02	\$1640.82	\$1453.85	\$1709.65	\$1749.11	\$2058.91	\$1773.17	\$2095.57	
			66"(1676mm)	TARA-3066-	S	X	7	1447.73	1717.81	1523.36	1793.44	1852.87	2180.55	1881.91	2223.03	
72"(1829mm)			TARA-3072-	S	X	7	1510.44	1794.80	1592.87	1877.23	1956.63	2302.19	1990.65	2350.49		
78"(1981mm)			TARA-3078-	S	X	7	1573.15	1871.79	1662.38	1961.02	2060.39	2423.83	2099.39	2477.95		
84"(2134mm)			TARA-3084-	S	X	7	1635.86	1948.78	1731.89	2044.81	2164.15	2545.47	2208.13	2605.41		
90"(2286mm)			TARA-3090-	S	X	7	1698.57	2025.77	1801.40	2128.60	2267.91	2667.11	2316.87	2732.87		
96"(2438mm)			TARA-3096-	S	X	7	1761.28	2102.76	1870.91	2212.39	2371.67	2788.75	2425.61	2860.33		
36"(914mm)			60"(1524mm)	TARA-3660-	S	X	7	\$1507.68	\$1777.76	\$1590.11	\$1860.19	\$1947.27	\$2274.95	\$1980.81	\$2321.93	
			66"(1676mm)	TARA-3666-	S	X	7	1582.38	1866.74	1672.97	1957.33	2069.91	2415.47	2109.33	2469.17	
		72"(1829mm)	TARA-3672-	S	X	7	1657.08	1955.72	1755.83	2054.47	2192.55	2555.99	2237.85	2616.41		
		78"(1981mm)	TARA-3678-	S	X	7	1731.78	2044.70	1838.69	2151.61	2315.19	2696.51	2366.37	2763.65		
		84"(2134mm)	TARA-3684-	S	X	7	1806.48	2133.68	1921.55	2248.75	2437.83	2837.03	2494.89	2910.89		
		90"(2286mm)	TARA-3690-	S	X	7	1881.18	2222.66	2004.41	2345.89	2560.47	2977.55	2623.41	3058.13		
		96"(2438mm)	TARA-3696-	S	X	7	1955.88	2311.64	2087.27	2443.03	2683.11	3118.07	2751.93	3205.37		
		42"(1067mm)	60"(1524mm)	TARA-4260-	S	X	7	\$1630.34	\$1914.70	\$1726.37	\$2010.73	\$2145.43	\$2490.99	\$2188.45	\$2548.29	
			66"(1676mm)	TARA-4266-	S	X	7	1717.03	2015.67	1822.58	2121.22	2286.95	2650.39	2336.75	2715.31	
72"(1829mm)			TARA-4272-	S	X	7	1803.72	2116.64	1918.79	2231.71	2428.47	2809.79	2485.05	2882.33		
78"(1981mm)			TARA-4278-	S	X	7	1890.41	2217.61	2015.00	2342.20	2569.99	2969.19	2633.35	3049.35		
84"(2134mm)			TARA-4284-	S	X	7	1977.10	2318.58	2111.21	2452.69	2711.51	3128.59	2781.65	3216.37		
90"(2286mm)			TARA-4290-	S	X	7	2063.79	2419.55	2207.42	2563.18	2853.03	3287.99	2929.95	3383.39		
96"(2438mm)			TARA-4296-	S	X	7	2150.48	2520.52	2303.63	2673.67	2994.55	3447.39	3078.25	3550.41		
48"(1219mm)			60"(1524mm)	TARA-4860-	S	X	7	\$1753.00	\$2051.64	\$1862.63	\$2161.27	\$2343.59	\$2707.03	\$2396.09	\$2774.65	
			66"(1676mm)	TARA-4866-	S	X	7	1851.68	2164.60	1972.19	2285.11	2503.99	2885.31	2564.17	2961.45	
		72"(1829mm)	TARA-4872-	S	X	7	1950.36	2277.56	2081.75	2408.95	2664.39	3063.59	2732.25	3148.25		
		78"(1981mm)	TARA-4878-	S	X	7	2049.04	2390.52	2191.31	2532.79	2824.79	3241.87	2900.33	3335.05		
		84"(2134mm)	TARA-4884-	S	X	7	2147.72	2503.48	2300.87	2656.63	2985.19	3420.15	3068.41	3521.85		
		90"(2286mm)	TARA-4890-	S	X	7	2246.40	2616.44	2410.43	2780.47	3145.59	3598.43	3236.49	3708.65		
		96"(2438mm)	TARA-4896-	S	X	7	2345.08	2729.40	2519.99	2904.31	3305.99	3776.71	3404.57	3895.45		

Planes Tables — Dual X Base

Laminate or Wood – Hexagon

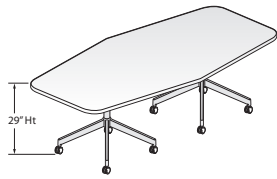

TARX-XC

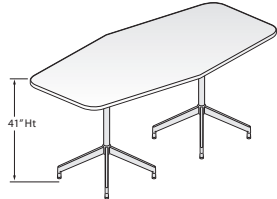

TARX-XG

Features

- Laminate top with knife edge or 3mm edgeband edges or wood veneer top with 3mm wood edgeband or knife edge. Edgeband tops are 3mm on user edge and 1mm on remaining edges.
- Includes 1 3/16"(30mm) thick standard top, bases and hardware.
- Fixed table height options are 29"(737mm) and 41"(1041mm).
- Casters (two locking/two non-locking) are available with: Light platinum or fog hub with graphite tread, or black hub with black tread.
- Glides available in graphite only and provide 1/2"(13mm) adjustment.
- Casters and glides are not interchangeable.
- Power modules are available for field installation; separately specified. Refer to Specification Guide.
- Ships unassembled.

Specification Tips

- Cutouts are designed for single sided flip top units and select workware connect interface modules (see workware price list).
- The following Planes products are separately specified:
 - Power modules
 - Grommet (field cut opening)
 - Wire Management

To Order, Specify:

1) Product number, including:

1 Surface Options:

- L** Laminate
- W** Wood

2 Edge Options:

Laminate:

- J** Edgeband
- F** Knife

Wood:

- K** Edgeband
- U** Knife

3 Cutout:

- N** No Cutout
- F** Center, Single-Sided/4 outlets, add **\$33.13** list
- J** Center, Single-Sided/6 outlets, add **\$33.13** list

4 Base:

- C** Caster
- G** Glide, add **\$133.68** list

5 Base Material:

- A** Painted
- B** Polished, add **\$545.88** list

- 2) Laminate surface color or wood finish color.
- 3) Edge trim color (laminate only).
- 4) Base trim color.

Note: **\$45.78** upcharge list for Metallic and accent trim colors.

Planes Tables — Dual X Base

Laminate or Wood – Hexagon

Height	Depth	Width	Number	① ② ③ ④ ⑤					Laminate A		Laminate B		Wood Group A		Wood Group B	
				J	F	J	F	K	U	K	U					
29"(737mm)	30"(762mm)	60"(1524mm)	TARX-3060-	S	X	4	\$1357.86	\$1622.66	\$1426.69	\$1691.49	\$1709.35	\$2019.15	\$1733.41	\$2055.81		
		66"(1676mm)	TARX-3066-	S	X	4	1421.41	1701.09	1497.04	1776.72	1813.11	2140.79	1842.15	2183.27		
		72"(1829mm)	TARX-3072-	S	X	4	1484.96	1779.52	1567.39	1861.95	1916.87	2262.43	1950.89	2310.73		
		78"(1981mm)	TARX-3078-	S	X	4	1548.51	1857.95	1637.74	1947.18	2020.63	2384.07	2059.63	2438.19		
		84"(2134mm)	TARX-3084-	S	X	4	1612.06	1936.38	1708.09	2032.41	2124.39	2505.71	2168.37	2565.65		
		90"(2286mm)	TARX-3090-	S	X	4	1675.61	2014.81	1778.44	2117.64	2228.15	2627.35	2277.11	2693.11		
		96"(2438mm)	TARX-3096-	S	X	4	1739.16	2093.24	1848.79	2202.87	2331.91	2748.99	2385.85	2820.57		
36"(914mm)	60"(1524mm)	TARX-3660-	S	X	4	\$1481.36	\$1761.04	\$1563.79	\$1843.47	\$1907.51	\$2235.19	\$1941.05	\$2282.17			
		66"(1676mm)	TARX-3666-	S	X	4	1556.90	1851.46	1647.49	1942.05	2030.15	2375.71	2069.57	2429.41		
		72"(1829mm)	TARX-3672-	S	X	4	1632.44	1941.88	1731.19	2040.63	2152.79	2516.23	2198.09	2576.65		
		78"(1981mm)	TARX-3678-	S	X	4	1707.98	2032.30	1814.89	2139.21	2275.43	2656.75	2326.61	2723.89		
		84"(2134mm)	TARX-3684-	S	X	4	1783.52	2122.72	1898.59	2237.79	2398.07	2797.27	2455.13	2871.13		
		90"(2286mm)	TARX-3690-	S	X	4	1859.06	2213.14	1982.29	2336.37	2520.71	2937.79	2583.65	3018.37		
		96"(2438mm)	TARX-3696-	S	X	4	1934.60	2303.56	2065.99	2434.95	2643.35	3078.31	2712.17	3165.61		
42"(1067mm)	60"(1524mm)	TARX-4260-	S	X	4	\$1604.86	\$1899.42	\$1700.89	\$1995.45	\$2105.67	\$2451.23	\$2148.69	\$2508.53			
		66"(1676mm)	TARX-4266-	S	X	4	1692.39	2001.83	1797.94	2107.38	2247.19	2610.63	2296.99	2675.55		
		72"(1829mm)	TARX-4272-	S	X	4	1779.92	2104.24	1894.99	2219.31	2388.71	2770.03	2445.29	2842.57		
		78"(1981mm)	TARX-4278-	S	X	4	1867.45	2206.65	1992.04	2331.24	2530.23	2929.43	2593.59	3009.59		
		84"(2134mm)	TARX-4284-	S	X	4	1954.98	2309.06	2089.09	2443.17	2671.75	3088.83	2741.89	3176.61		
		90"(2286mm)	TARX-4290-	S	X	4	2042.51	2411.47	2186.14	2555.10	2813.27	3248.23	2890.19	3343.63		
		96"(2438mm)	TARX-4296-	S	X	4	2130.04	2513.88	2283.19	2667.03	2954.79	3407.63	3038.49	3510.65		
48"(1219mm)	60"(1524mm)	TARX-4860-	S	X	4	\$1728.36	\$2037.80	\$1837.99	\$2147.43	\$2303.83	\$2667.27	\$2356.33	\$2734.89			
		66"(1676mm)	TARX-4866-	S	X	4	1827.88	2152.20	1948.39	2272.71	2464.23	2845.55	2524.41	2921.69		
		72"(1829mm)	TARX-4872-	S	X	4	1927.40	2266.60	2058.79	2397.99	2624.63	3023.83	2692.49	3108.49		
		78"(1981mm)	TARX-4878-	S	X	4	2026.92	2381.00	2169.19	2523.27	2785.03	3202.11	2860.57	3295.29		
		84"(2134mm)	TARX-4884-	S	X	4	2126.44	2495.40	2279.59	2648.55	2945.43	3380.39	3028.65	3482.09		
		90"(2286mm)	TARX-4890-	S	X	4	2225.96	2609.80	2389.99	2773.83	3105.83	3558.67	3196.73	3668.89		
		96"(2438mm)	TARX-4896-	S	X	4	2325.48	2724.20	2500.39	2899.11	3266.23	3736.95	3364.81	3855.69		
40"(1016mm)	30"(762mm)	60"(1524mm)	TARX-3060-	S	X	7	\$1424.70	\$1689.50	\$1493.53	\$1758.33	\$1776.19	\$2085.99	\$1800.25	\$2122.65		
		66"(1676mm)	TARX-3066-	S	X	7	1488.25	1767.93	1563.88	1843.56	1879.95	2207.63	1908.99	2250.11		
		72"(1829mm)	TARX-3072-	S	X	7	1551.80	1846.36	1634.23	1928.79	1983.71	2329.27	2017.73	2377.57		
		78"(1981mm)	TARX-3078-	S	X	7	1615.35	1924.79	1704.58	2014.02	2087.47	2450.91	2126.47	2505.03		
		84"(2134mm)	TARX-3084-	S	X	7	1678.90	2003.22	1774.93	2099.25	2191.23	2572.55	2235.21	2632.49		
		90"(2286mm)	TARX-3090-	S	X	7	1742.45	2081.65	1845.28	2184.48	2294.99	2694.19	2343.95	2759.95		
		96"(2438mm)	TARX-3096-	S	X	7	1806.00	2160.08	1915.63	2269.71	2398.75	2815.83	2452.69	2887.41		
36"(914mm)	60"(1524mm)	TARX-3660-	S	X	7	\$1548.20	\$1827.88	\$1630.63	\$1910.31	\$1974.35	\$2302.03	\$2007.89	\$2349.01			
		66"(1676mm)	TARX-3666-	S	X	7	1623.74	1918.30	1714.33	2008.89	2096.99	2442.55	2136.41	2496.25		
		72"(1829mm)	TARX-3672-	S	X	7	1699.28	2008.72	1798.03	2107.47	2219.63	2583.07	2264.93	2643.49		
		78"(1981mm)	TARX-3678-	S	X	7	1774.82	2099.14	1881.73	2206.05	2342.27	2723.59	2393.45	2790.73		
		84"(2134mm)	TARX-3684-	S	X	7	1850.36	2189.56	1965.43	2304.63	2464.91	2864.11	2521.97	2937.97		
		90"(2286mm)	TARX-3690-	S	X	7	1925.90	2279.98	2049.13	2403.21	2587.55	3004.63	2650.49	3085.21		
		96"(2438mm)	TARX-3696-	S	X	7	2001.44	2370.40	2132.83	2501.79	2710.19	3145.15	2779.01	3232.45		
42"(1067mm)	60"(1524mm)	TARX-4260-	S	X	7	\$1671.70	\$1966.26	\$1767.73	\$2062.29	\$2172.51	\$2518.07	\$2215.53	\$2575.37			
		66"(1676mm)	TARX-4266-	S	X	7	1759.23	2068.67	1864.78	2174.22	2314.03	2677.47	2363.83	2742.39		
		72"(1829mm)	TARX-4272-	S	X	7	1846.76	2171.08	1961.83	2286.15	2455.55	2836.87	2512.13	2909.41		
		78"(1981mm)	TARX-4278-	S	X	7	1934.29	2273.49	2058.88	2398.08	2597.07	2996.27	2660.43	3076.43		
		84"(2134mm)	TARX-4284-	S	X	7	2021.82	2375.90	2155.93	2510.01	2738.59	3155.67	2808.73	3243.45		
		90"(2286mm)	TARX-4290-	S	X	7	2109.35	2478.31	2252.98	2621.94	2880.11	3315.07	2957.03	3410.47		
		96"(2438mm)	TARX-4296-	S	X	7	2196.88	2580.72	2350.03	2733.87	3021.63	3474.47	3105.33	3577.49		
48"(1219mm)	60"(1524mm)	TARX-4860-	S	X	7	\$1795.20	\$2104.64	\$1904.83	\$2214.27	\$2370.67	\$2734.11	\$2423.17	\$2801.73			
		66"(1676mm)	TARX-4866-	S	X	7	1894.72	2219.04	2015.23	2339.55	2531.07	2912.39	2591.25	2988.53		
		72"(1829mm)	TARX-4872-	S	X	7	1994.24	2333.44	2125.63	2464.83	2691.47	3090.67	2759.33	3175.33		
		78"(1981mm)	TARX-4878-	S	X	7	2093.76	2447.84	2236.03	2590.11	2851.87	3268.95	2927.41	3362.13		
		84"(2134mm)	TARX-4884-	S	X	7	2193.28	2562.24	2346.43	2715.39	3012.27	3447.23	3095.49	3548.93		
		90"(2286mm)	TARX-4890-	S	X	7	2292.80	2676.64	2456.83	2840.67	3172.67	3625.51	3263.57	3735.73		
		96"(2438mm)	TARX-4896-	S	X	7	2392.32	2791.04	2567.23	2965.95	3333.07	3803.79	3431.65	3922.53		

Planes Tables — Dual X Base

Laminate or Wood – Pebble



TARP-XC



TARP-XG

Features

- Laminate top with knife edge or 3mm edgeband edges or wood veneer top with 3mm wood edgeband or knife edge. Edgeband tops are 3mm on user edge and 1mm on remaining edges.
- Includes 1 3/16" (30mm) thick standard top, bases and hardware.
- Fixed table height options are 29" (737mm) and 41" (1041mm).
- Casters (two locking/two non-locking) are available with: Light platinum or fog hub with graphite tread, or black hub with black tread.
- Glides available in graphite only and provide 1/2" (13mm) adjustment.
- Casters and glides are not interchangeable.
- Power modules are available for field installation; separately specified. Refer to Specification Guide.
- Ships unassembled.

Specification Tips

- Cutouts are designed for single sided flip top units and select workware connect interface modules (see workware price list).
- The following Planes products are separately specified:
 - Power modules
 - Grommet (field cut opening)
 - Wire Management

To Order, Specify:

1) Product number, including:

1 Surface Options:

- L** Laminate
- W** Wood

2 Edge Options:

Laminate:

- J** Edgeband
- F** Knife

Wood:

- K** Edgeband
- U** Knife

3 Cutout:

- N** No Cutout
- F** Center, Single-Sided/4 outlets, add **\$33.13** list
- J** Center, Single-Sided/6 outlets, add **\$33.13** list

4 Base:

- C** Caster
- G** Glide, add **\$133.68** list

5 Base Material:

- A** Painted
- B** Polished, add **\$545.88** list

- 2) Laminate surface color or wood finish color.
- 3) Edge trim color (laminated only).
- 4) Base trim color.

Note: **\$45.78** upcharge list for Metallic and accent trim colors.

Planes Tables — Dual X Base

Laminate or Wood – Pebble

Height	Depth	Width	Number	① ② ③ ④ ⑤					Laminate A		Laminate B		Wood Group A		Wood Group B	
				J	F	J	F	K	U	K	U					
29"(737mm)	30"(762mm)	60"(1524mm)	TARP-3060-	S	X	4	\$1357.86	\$1581.06	\$1426.69	\$1649.89	\$1709.35	\$1977.55	\$1733.41	\$2014.21		
		66"(1676mm)	TARP-3066-	S	X	4	1421.41	1659.49	1497.04	1735.12	1813.11	2099.19	1842.15	2141.67		
		72"(1829mm)	TARP-3072-	S	X	4	1484.96	1737.92	1567.39	1820.35	1916.87	2220.83	1950.89	2269.13		
		78"(1981mm)	TARP-3078-	S	X	4	1548.51	1816.35	1637.74	1905.58	2020.63	2342.47	2059.63	2396.59		
		84"(2134mm)	TARP-3084-	S	X	4	1612.06	1894.78	1708.09	1990.81	2124.39	2464.11	2168.37	2524.05		
		90"(2286mm)	TARP-3090-	S	X	4	1675.61	1973.21	1778.44	2076.04	2228.15	2585.75	2277.11	2651.51		
	96"(2438mm)	TARP-3096-	S	X	4	1739.16	2051.64	1848.79	2161.27	2331.91	2707.39	2385.85	2778.97			
	36"(914mm)	60"(1524mm)	TARP-3660-	S	X	4	\$1481.36	\$1719.44	\$1563.79	\$1801.87	\$1907.51	\$2193.59	\$1941.05	\$2240.57		
		66"(1676mm)	TARP-3666-	S	X	4	1556.90	1809.86	1647.49	1900.45	2030.15	2334.11	2069.57	2387.81		
		72"(1829mm)	TARP-3672-	S	X	4	1632.44	1900.28	1731.19	1999.03	2152.79	2474.63	2198.09	2535.05		
		78"(1981mm)	TARP-3678-	S	X	4	1707.98	1990.70	1814.89	2097.61	2275.43	2615.15	2326.61	2682.29		
		84"(2134mm)	TARP-3684-	S	X	4	1783.52	2081.12	1898.59	2196.19	2398.07	2755.67	2455.13	2829.53		
90"(2286mm)		TARP-3690-	S	X	4	1859.06	2171.54	1982.29	2294.77	2520.71	2896.19	2583.65	2976.77			
42"(1067mm)	60"(1524mm)	TARP-4260-	S	X	4	\$1604.86	\$1857.82	\$1700.89	\$1953.85	\$2105.67	\$2409.63	\$2148.69	\$2466.93			
		TARP-4266-	S	X	4	1692.39	1960.23	1797.94	2065.78	2247.19	2569.03	2296.99	2633.95			
		TARP-4272-	S	X	4	1779.92	2062.64	1894.99	2177.71	2388.71	2728.43	2445.29	2800.97			
		TARP-4278-	S	X	4	1867.45	2165.05	1992.04	2289.64	2530.23	2887.83	2593.59	2967.99			
		TARP-4284-	S	X	4	1954.98	2267.46	2089.09	2401.57	2671.75	3047.23	2741.89	3135.01			
		TARP-4290-	S	X	4	2042.51	2369.87	2186.14	2513.50	2813.27	3206.63	2890.19	3302.03			
	66"(1676mm)	TARP-4296-	S	X	4	2130.04	2472.28	2283.19	2625.43	2954.79	3366.03	3038.49	3469.05			
		TARP-4860-	S	X	4	\$1728.36	\$1996.20	\$1837.99	\$2105.83	\$2303.83	\$2625.67	\$2356.33	\$2693.29			
		TARP-4866-	S	X	4	1827.88	2110.60	1948.39	2231.11	2464.23	2803.95	2524.41	2880.09			
		TARP-4872-	S	X	4	1927.40	2225.00	2058.79	2356.39	2624.63	2982.23	2692.49	3066.89			
		TARP-4878-	S	X	4	2026.92	2339.40	2169.19	2481.67	2785.03	3160.51	2860.57	3253.69			
		TARP-4884-	S	X	4	2126.44	2453.80	2279.59	2606.95	2945.43	3338.79	3028.65	3440.49			
48"(1219mm)	60"(1524mm)	TARP-4890-	S	X	4	2225.96	2568.20	2389.99	2732.23	3105.83	3517.07	3196.73	3627.29			
		TARP-4896-	S	X	4	2325.48	2682.60	2500.39	2857.51	3266.23	3695.35	3364.81	3814.09			
		TARP-3060-	S	X	7	\$1424.70	\$1647.90	\$1493.53	\$1716.73	\$1776.19	\$2044.39	\$1800.25	\$2081.05			
		TARP-3066-	S	X	7	1488.25	1726.33	1563.88	1801.96	1879.95	2166.03	1908.99	2208.51			
		TARP-3072-	S	X	7	1551.80	1804.76	1634.23	1887.19	1983.71	2287.67	2017.73	2335.97			
		TARP-3078-	S	X	7	1615.35	1883.19	1704.58	1972.42	2087.47	2409.31	2126.47	2463.43			
	66"(1676mm)	TARP-3084-	S	X	7	1678.90	1961.62	1774.93	2057.65	2191.23	2530.95	2235.21	2590.89			
		TARP-3090-	S	X	7	1742.45	2040.05	1845.28	2142.88	2294.99	2652.59	2343.95	2718.35			
		TARP-3096-	S	X	7	1806.00	2118.48	1915.63	2228.11	2398.75	2774.23	2452.69	2845.81			
		TARP-3660-	S	X	7	\$1548.20	\$1786.28	\$1630.63	\$1868.71	\$1974.35	\$2260.43	\$2007.89	\$2307.41			
		TARP-3666-	S	X	7	1623.74	1876.70	1714.33	1967.29	2096.99	2400.95	2136.41	2454.65			
		TARP-3672-	S	X	7	1699.28	1967.12	1798.03	2065.87	2219.63	2541.47	2264.93	2601.89			
36"(914mm)	60"(1524mm)	TARP-3678-	S	X	7	1774.82	2057.54	1881.73	2164.45	2342.27	2681.99	2393.45	2749.13			
		TARP-3684-	S	X	7	1850.36	2147.96	1965.43	2263.03	2464.91	2822.51	2521.97	2896.37			
		TARP-3690-	S	X	7	1925.90	2238.38	2049.13	2361.61	2587.55	2963.03	2650.49	3043.61			
		TARP-3696-	S	X	7	2001.44	2328.80	2132.83	2460.19	2710.19	3103.55	2779.01	3190.85			
		TARP-4260-	S	X	7	\$1671.70	\$1924.66	\$1767.73	\$2020.69	\$2172.51	\$2476.47	\$2215.53	\$2533.77			
		TARP-4266-	S	X	7	1759.23	2027.07	1864.78	2132.62	2314.03	2635.87	2363.83	2700.79			
	66"(1676mm)	TARP-4272-	S	X	7	1846.76	2129.48	1961.83	2244.55	2455.55	2795.27	2512.13	2867.81			
		TARP-4278-	S	X	7	1934.29	2231.89	2058.88	2356.48	2597.07	2954.67	2660.43	3034.83			
		TARP-4284-	S	X	7	2021.82	2334.30	2155.93	2468.41	2738.59	3114.07	2808.73	3201.85			
		TARP-4290-	S	X	7	2109.35	2436.71	2252.98	2580.34	2880.11	3273.47	2957.03	3368.87			
		TARP-4296-	S	X	7	2196.88	2539.12	2350.03	2692.27	3021.63	3432.87	3105.33	3535.89			
		TARP-4860-	S	X	7	\$1795.20	\$2063.04	\$1904.83	\$2172.67	\$2370.67	\$2692.51	\$2423.17	\$2760.13			
48"(1219mm)	60"(1524mm)	TARP-4866-	S	X	7	1894.72	2177.44	2015.23	2297.95	2531.07	2870.79	2591.25	2946.93			
		TARP-4872-	S	X	7	1994.24	2291.84	2125.63	2423.23	2691.47	3049.07	2759.33	3133.73			
		TARP-4878-	S	X	7	2093.76	2406.24	2236.03	2548.51	2851.87	3227.35	2927.41	3320.53			
		TARP-4884-	S	X	7	2193.28	2520.64	2346.43	2673.79	3012.27	3405.63	3095.49	3507.33			
		TARP-4890-	S	X	7	2292.80	2635.04	2456.83	2799.07	3172.67	3583.91	3263.57	3694.13			
		TARP-4896-	S	X	7	2392.32	2749.44	2567.23	2924.35	3333.07	3762.19	3431.65	3880.93			

Planes Tables — Dual Disc Base

Laminate or Wood – Rectangle

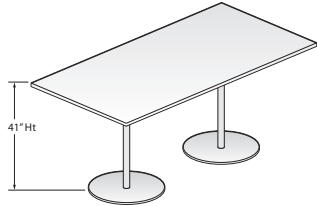
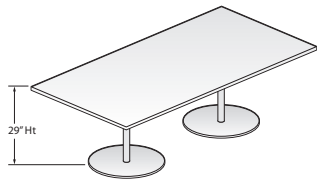

TARA-D

Features

- Laminate top with knife edge or 3mm edgeband edges or wood veneer top with 3mm wood edgeband or knife edge. Edgeband tops are 3mm on user edge and 1mm on remaining edges.
- Includes 1 3/16" (30mm) thick standard top, bases and hardware.
- Fixed table height options are 29" (737mm) and 41" (1041mm).
- Power modules are available for field installation; separately specified. Refer to Specification Guide.
- Ships unassembled.

Specification Tips

- Cutouts are designed for single sided flip top units and select workware connect interface modules (see workware price list).
- The following Planes products are separately specified:
 - Power modules
 - Grommet (field cut opening)
 - Wire Management

To Order, Specify:

1) Product number, including:

① Surface Options:

- L** Laminate
- W** Wood

② Edge Options:

Laminate:

- J** Edgeband
- F** Knife

Wood:

- K** Edgeband
- U** Knife

③ Cutout:

- N** No Cutout
- F** Center, Single-Sided/4 outlets, add **\$33.13** list
- J** Center, Single-Sided/6 outlets, add **\$33.13** list

2) Laminate surface color or wood finish color.

3) Edge trim color (laminated only).

4) Base trim color.

Note: **\$45.78** upcharge list for Metallic and accent trim colors.

Planes Tables — Dual Disc Base

Laminate or Wood – Rectangle

Height	Depth	Width	Number ① ② ③	Laminate A		Laminate B		Wood Group A		Wood Group B	
				J	F	J	F	K	U	K	U
29"(737mm)	30"(762mm)	60"(1524mm)	TARA-3060-■ ■ ■ S ■ DN4A	\$2027.33	\$2283.13	\$2096.16	\$2351.96	\$2391.42	\$2701.22	\$2415.48	\$2737.88
		66"(1676mm)	TARA-3066-■ ■ ■ S ■ DN4A	2090.04	2360.12	2165.67	2435.75	2495.18	2822.86	2524.22	2865.34
		72"(1829mm)	TARA-3072-■ ■ ■ S ■ DN4A	2152.75	2437.11	2235.18	2519.54	2598.94	2944.50	2632.96	2992.80
		78"(1981mm)	TARA-3078-■ ■ ■ S ■ DN4A	2215.46	2514.10	2304.69	2603.33	2702.70	3066.14	2741.70	3120.26
		84"(2134mm)	TARA-3084-■ ■ ■ S ■ DN4A	2278.17	2591.09	2374.20	2687.12	2806.46	3187.78	2850.44	3247.72
		90"(2286mm)	TARA-3090-■ ■ ■ S ■ DN4A	2340.88	2668.08	2443.71	2770.91	2910.22	3309.42	2959.18	3375.18
	36"(914mm)	60"(1524mm)	TARA-3096-■ ■ ■ S ■ DN4A	2403.59	2745.07	2513.22	2854.70	3013.98	3431.06	3067.92	3502.64
		66"(1676mm)	TARA-3660-■ ■ ■ S ■ DN4A	\$2149.99	\$2420.07	\$2232.42	\$2502.50	\$2589.58	\$2917.26	\$2623.12	\$2964.24
		72"(1829mm)	TARA-3666-■ ■ ■ S ■ DN4A	2224.69	2509.05	2315.28	2599.64	2712.22	3057.78	2751.64	3111.48
		78"(1981mm)	TARA-3672-■ ■ ■ S ■ DN4A	2299.39	2598.03	2398.14	2696.78	2834.86	3198.30	2880.16	3258.72
		84"(2134mm)	TARA-3678-■ ■ ■ S ■ DN4A	2374.09	2687.01	2481.00	2793.92	2957.50	3338.82	3008.68	3405.96
		90"(2286mm)	TARA-3684-■ ■ ■ S ■ DN4A	2448.79	2775.99	2563.86	2891.06	3080.14	3479.34	3137.20	3553.20
	42"(1067mm)	60"(1524mm)	TARA-3690-■ ■ ■ S ■ DN4A	2523.49	2864.97	2646.72	2988.20	3202.78	3619.86	3265.72	3700.44
		66"(1676mm)	TARA-3696-■ ■ ■ S ■ DN4A	2598.19	2953.95	2729.58	3085.34	3325.42	3760.38	3394.24	3847.68
		72"(1829mm)	TARA-4260-■ ■ ■ S ■ DN4A	\$2272.65	\$2557.01	\$2368.68	\$2653.04	\$2787.74	\$3133.30	\$2830.76	\$3190.60
		78"(1981mm)	TARA-4266-■ ■ ■ S ■ DN4A	2359.34	2657.98	2464.89	2763.53	2929.26	3292.70	2979.06	3357.62
		84"(2134mm)	TARA-4272-■ ■ ■ S ■ DN4A	2446.03	2758.95	2561.10	2874.02	3070.78	3452.10	3127.36	3524.64
		90"(2286mm)	TARA-4278-■ ■ ■ S ■ DN4A	2532.72	2859.92	2657.31	2984.51	3212.30	3611.50	3275.66	3691.66
48"(1219mm)	60"(1524mm)	TARA-4284-■ ■ ■ S ■ DN4A	2619.41	2960.89	2753.52	3095.00	3353.82	3770.90	3423.96	3858.68	
	66"(1676mm)	TARA-4290-■ ■ ■ S ■ DN4A	2706.10	3061.86	2849.73	3205.49	3495.34	3930.30	3572.26	4025.70	
	72"(1829mm)	TARA-4296-■ ■ ■ S ■ DN4A	2792.79	3162.83	2945.94	3315.98	3636.86	4089.70	3720.56	4192.72	
	78"(1981mm)	TARA-4860-■ ■ ■ S ■ DN4A	\$2395.31	\$2693.95	\$2504.94	\$2803.58	\$2985.90	\$3349.34	\$3038.40	\$3416.96	
	84"(2134mm)	TARA-4866-■ ■ ■ S ■ DN4A	2493.99	2806.91	2614.50	2927.42	3146.30	3527.62	3206.48	3603.76	
	90"(2286mm)	TARA-4872-■ ■ ■ S ■ DN4A	2592.67	2919.87	2724.06	3051.26	3306.70	3705.90	3374.56	3790.56	
40"(1016mm)	30"(762mm)	60"(1524mm)	TARA-4878-■ ■ ■ S ■ DN4A	2691.35	3032.83	2833.62	3175.10	3467.10	3884.18	3542.64	3977.36
		66"(1676mm)	TARA-4884-■ ■ ■ S ■ DN4A	2790.03	3145.79	2943.18	3298.94	3627.50	4062.46	3710.72	4164.16
		72"(1829mm)	TARA-4890-■ ■ ■ S ■ DN4A	2888.71	3258.75	3052.74	3422.78	3787.90	4240.74	3878.80	4350.96
		78"(1981mm)	TARA-4896-■ ■ ■ S ■ DN4A	2987.39	3371.71	3162.30	3546.62	3948.30	4419.02	4046.88	4537.76
		84"(2134mm)	TARA-3060-■ ■ ■ S ■ DN7A	\$2094.17	\$2349.97	\$2163.00	\$2418.80	\$2458.26	\$2768.06	\$2482.32	\$2804.72
		90"(2286mm)	TARA-3066-■ ■ ■ S ■ DN7A	2156.88	2426.96	2232.51	2502.59	2562.02	2889.70	2591.06	2932.18
	36"(914mm)	60"(1524mm)	TARA-3072-■ ■ ■ S ■ DN7A	2219.59	2503.95	2302.02	2586.38	2665.78	3011.34	2699.80	3059.64
		66"(1676mm)	TARA-3078-■ ■ ■ S ■ DN7A	2282.30	2580.94	2371.53	2670.17	2769.54	3132.98	2808.54	3187.10
		72"(1829mm)	TARA-3084-■ ■ ■ S ■ DN7A	2345.01	2657.93	2441.04	2753.96	2873.30	3254.62	2917.28	3314.56
		78"(1981mm)	TARA-3090-■ ■ ■ S ■ DN7A	2407.72	2734.92	2510.55	2837.75	2977.06	3376.26	3026.02	3442.02
		84"(2134mm)	TARA-3096-■ ■ ■ S ■ DN7A	2470.43	2811.91	2580.06	2921.54	3080.82	3497.90	3134.76	3569.48
		90"(2286mm)	TARA-3660-■ ■ ■ S ■ DN7A	\$2216.83	\$2486.91	\$2299.26	\$2569.34	\$2656.42	\$2984.10	\$2689.96	\$3031.08
	42"(1067mm)	60"(1524mm)	TARA-3666-■ ■ ■ S ■ DN7A	2291.53	2575.89	2382.12	2666.48	2779.06	3124.62	2818.48	3178.32
		66"(1676mm)	TARA-3672-■ ■ ■ S ■ DN7A	2366.23	2664.87	2464.98	2763.62	2901.70	3265.14	2947.00	3325.56
		72"(1829mm)	TARA-3678-■ ■ ■ S ■ DN7A	2440.93	2753.85	2547.84	2860.76	3024.34	3405.66	3075.52	3472.80
		78"(1981mm)	TARA-3684-■ ■ ■ S ■ DN7A	2515.63	2842.83	2630.70	2957.90	3146.98	3546.18	3204.04	3620.04
		84"(2134mm)	TARA-3690-■ ■ ■ S ■ DN7A	2590.33	2931.81	2713.56	3055.04	3269.62	3686.70	3332.56	3767.28
		90"(2286mm)	TARA-3696-■ ■ ■ S ■ DN7A	2665.03	3020.79	2796.42	3152.18	3392.26	3827.22	3461.08	3914.52
48"(1219mm)	60"(1524mm)	TARA-4260-■ ■ ■ S ■ DN7A	\$2339.49	\$2623.85	\$2435.52	\$2719.88	\$2854.58	\$3200.14	\$2897.60	\$3257.44	
	66"(1676mm)	TARA-4266-■ ■ ■ S ■ DN7A	2426.18	2724.82	2531.73	2830.37	2996.10	3359.54	3045.90	3424.46	
	72"(1829mm)	TARA-4272-■ ■ ■ S ■ DN7A	2512.87	2825.79	2627.94	2940.86	3137.62	3518.94	3194.20	3591.48	
	78"(1981mm)	TARA-4278-■ ■ ■ S ■ DN7A	2599.56	2926.76	2724.15	3051.35	3279.14	3678.34	3342.50	3758.50	
	84"(2134mm)	TARA-4284-■ ■ ■ S ■ DN7A	2686.25	3027.73	2820.36	3161.84	3420.66	3837.74	3490.80	3925.52	
	90"(2286mm)	TARA-4290-■ ■ ■ S ■ DN7A	2772.94	3128.70	2916.57	3272.33	3562.18	3997.14	3639.10	4092.54	
48"(1219mm)	60"(1524mm)	TARA-4296-■ ■ ■ S ■ DN7A	2859.63	3229.67	3012.78	3382.82	3703.70	4156.54	3787.40	4259.56	
	66"(1676mm)	TARA-4860-■ ■ ■ S ■ DN7A	\$2462.15	\$2760.79	\$2571.78	\$2870.42	\$3052.74	\$3416.18	\$3105.24	\$3483.80	
	72"(1829mm)	TARA-4866-■ ■ ■ S ■ DN7A	2560.83	2873.75	2681.34	2994.26	3213.14	3594.46	3273.32	3670.60	
	78"(1981mm)	TARA-4872-■ ■ ■ S ■ DN7A	2659.51	2986.71	2790.90	3118.10	3373.54	3772.74	3441.40	3857.40	
	84"(2134mm)	TARA-4878-■ ■ ■ S ■ DN7A	2758.19	3099.67	2900.46	3241.94	3533.94	3951.02	3609.48	4044.20	
	90"(2286mm)	TARA-4884-■ ■ ■ S ■ DN7A	2856.87	3212.63	3010.02	3365.78	3694.34	4129.30	3777.56	4231.00	
48"(1219mm)	60"(1524mm)	TARA-4890-■ ■ ■ S ■ DN7A	2955.55	3325.59	3119.58	3489.62	3854.74	4307.58	3945.64	4417.80	
	66"(1676mm)	TARA-4896-■ ■ ■ S ■ DN7A	3054.23	3438.55	3229.14	3613.46	4015.14	4485.86	4113.72	4604.60	

Planes Tables — Dual Disc Base

Laminate or Wood – Hexagon

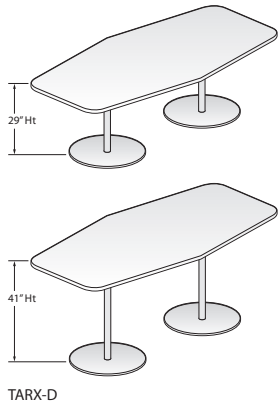

Features

- Laminate top with knife edge or 3mm edgeband edges or wood veneer top with 3mm wood edgeband or knife edge. Edgeband tops are 3mm on user edge and 1mm on remaining edges.
- Includes 1 3/16" (30mm) thick standard top, bases and hardware.
- Fixed table height options are 29" (737mm) and 41" (1041mm).
- Power modules are available for field installation; separately specified. Refer to Specification Guide.
- Ships unassembled.

Specification Tips

- Cutouts are designed for single sided flip top units and select workware connect interface modules (see workware price list).
- The following Planes products are separately specified:
 - Power modules
 - Grommet (field cut opening)
 - Wire Management

To Order, Specify:

1) Product number, including:

① Surface Options:

- L** Laminate
- W** Wood

② Edge Options:

Laminate:

- J** Edgeband
- F** Knife

Wood:

- K** Edgeband
- U** Knife

③ Cutout:

- N** No Cutout
- F** Center, Single-Sided/4 outlets, add **\$33.13** list
- J** Center, Single-Sided/6 outlets, add **\$33.13** list

2) Laminate surface color or wood finish color.

3) Edge trim color (laminated only).

4) Base trim color.

Note: **\$45.78** upcharge list for Metallic and accent trim colors.

Planes Tables — Dual Disc Base

Laminate or Wood – Hexagon

Height	Depth	Width	Number ① ② ③	Laminate A		Laminate B		Wood Group A		Wood Group B			
				J	F	J	F	K	U	K	U		
29"(737mm)	30"(762mm)	60"(1524mm)	TARX-3060-	S	DN4A	\$2067.01	\$2331.81	\$2135.84	\$2400.64	\$2418.50	\$2728.30	\$2442.56	\$2764.96
		66"(1676mm)	TARX-3066-	S	DN4A	2130.56	2410.24	2206.19	2485.87	2522.26	2849.94	2551.30	2892.42
		72"(1829mm)	TARX-3072-	S	DN4A	2194.11	2488.67	2276.54	2571.10	2626.02	2971.58	2660.04	3019.88
		78"(1981mm)	TARX-3078-	S	DN4A	2257.66	2567.10	2346.89	2656.33	2729.78	3093.22	2768.78	3147.34
		84"(2134mm)	TARX-3084-	S	DN4A	2321.21	2645.53	2417.24	2741.56	2833.54	3214.86	2877.52	3274.80
		90"(2286mm)	TARX-3090-	S	DN4A	2384.76	2723.96	2487.59	2826.79	2937.30	3336.50	2986.26	3402.26
	36"(914mm)	60"(1524mm)	TARX-3096-	S	DN4A	2448.31	2802.39	2557.94	2912.02	3041.06	3458.14	3095.00	3529.72
		66"(1676mm)	TARX-3660-	S	DN4A	\$2190.51	\$2470.19	\$2272.94	\$2552.62	\$2616.66	\$2944.34	\$2650.20	\$2991.32
		72"(1829mm)	TARX-3666-	S	DN4A	2266.05	2560.61	2356.64	2651.20	2739.30	3084.86	2778.72	3138.56
		78"(1981mm)	TARX-3672-	S	DN4A	2341.59	2651.03	2440.34	2749.78	2861.94	3225.38	2907.24	3285.80
		84"(2134mm)	TARX-3678-	S	DN4A	2417.13	2741.45	2524.04	2848.36	2984.58	3365.90	3035.76	3433.04
		90"(2286mm)	TARX-3684-	S	DN4A	2492.67	2831.87	2607.74	2946.94	3107.22	3506.42	3164.28	3580.28
	42"(1067mm)	60"(1524mm)	TARX-3690-	S	DN4A	2568.21	2922.29	2691.44	3045.52	3229.86	3646.94	3292.80	3727.52
		66"(1676mm)	TARX-3696-	S	DN4A	2643.75	3012.71	2775.14	3144.10	3352.50	3787.46	3421.32	3874.76
		72"(1829mm)	TARX-4260-	S	DN4A	\$2314.01	\$2608.57	\$2410.04	\$2704.60	\$2814.82	\$3160.38	\$2857.84	\$3217.68
		78"(1981mm)	TARX-4266-	S	DN4A	2401.54	2710.98	2507.09	2816.53	2956.34	3319.78	3006.14	3384.70
		84"(2134mm)	TARX-4272-	S	DN4A	2489.07	2813.39	2604.14	2928.46	3097.86	3479.18	3154.44	3551.72
		90"(2286mm)	TARX-4278-	S	DN4A	2576.60	2915.80	2701.19	3040.39	3239.38	3638.58	3302.74	3718.74
48"(1219mm)	60"(1524mm)	TARX-4284-	S	DN4A	2664.13	3018.21	2798.24	3152.32	3380.90	3797.98	3451.04	3885.76	
	66"(1676mm)	TARX-4290-	S	DN4A	2751.66	3120.62	2895.29	3264.25	3522.42	3957.38	3599.34	4052.78	
	72"(1829mm)	TARX-4296-	S	DN4A	2839.19	3223.03	2992.34	3376.18	3663.94	4116.78	3747.64	4219.80	
	78"(1981mm)	TARX-4860-	S	DN4A	\$2437.51	\$2746.95	\$2547.14	\$2856.58	\$3012.98	\$3376.42	\$3065.48	\$3444.04	
	84"(2134mm)	TARX-4866-	S	DN4A	2537.03	2861.35	2657.54	2981.86	3173.38	3554.70	3233.56	3630.84	
	90"(2286mm)	TARX-4872-	S	DN4A	2636.55	2975.75	2767.94	3107.14	3333.78	3732.98	3401.64	3817.64	
40"(1016mm)	60"(1524mm)	TARX-4878-	S	DN4A	2736.07	3090.15	2878.34	3232.42	3494.18	3911.26	3569.72	4004.44	
	66"(1676mm)	TARX-4884-	S	DN4A	2835.59	3204.55	2988.74	3357.70	3654.58	4089.54	3737.80	4191.24	
	72"(1829mm)	TARX-4890-	S	DN4A	2935.11	3318.95	3099.14	3482.98	3814.98	4267.82	3905.88	4378.04	
	78"(1981mm)	TARX-4896-	S	DN4A	3034.63	3433.35	3209.54	3608.26	3975.38	4446.10	4073.96	4564.84	
	84"(2134mm)	TARX-3060-	S	DN7A	\$2133.85	\$2398.65	\$2202.68	\$2467.48	\$2485.34	\$2795.14	\$2509.40	\$2831.80	
	90"(2286mm)	TARX-3066-	S	DN7A	2197.40	2477.08	2273.03	2552.71	2589.10	2916.78	2618.14	2959.26	
36"(914mm)	60"(1524mm)	TARX-3072-	S	DN7A	2260.95	2555.51	2343.38	2637.94	2692.86	3038.42	2726.88	3086.72	
	66"(1676mm)	TARX-3078-	S	DN7A	2324.50	2633.94	2413.73	2723.17	2796.62	3160.06	2835.62	3214.18	
	72"(1829mm)	TARX-3084-	S	DN7A	2388.05	2712.37	2484.08	2808.40	2900.38	3281.70	2944.36	3341.64	
	78"(1981mm)	TARX-3090-	S	DN7A	2451.60	2790.80	2554.43	2893.63	3004.14	3403.34	3053.10	3469.10	
	84"(2134mm)	TARX-3096-	S	DN7A	2515.15	2869.23	2624.78	2978.86	3107.90	3524.98	3161.84	3596.56	
	90"(2286mm)	TARX-3660-	S	DN7A	\$2257.35	\$2537.03	\$2339.78	\$2619.46	\$2683.50	\$3011.18	\$2717.04	\$3058.16	
	66"(1676mm)	TARX-3666-	S	DN7A	2332.89	2627.45	2423.48	2718.04	2806.14	3151.70	2845.56	3205.40	
	72"(1829mm)	TARX-3672-	S	DN7A	2408.43	2717.87	2507.18	2816.62	2928.78	3292.22	2974.08	3352.64	
	78"(1981mm)	TARX-3678-	S	DN7A	2483.97	2808.29	2590.88	2915.20	3051.42	3432.74	3102.60	3499.88	
	84"(2134mm)	TARX-3684-	S	DN7A	2559.51	2898.71	2674.58	3013.78	3174.06	3573.26	3231.12	3647.12	
	90"(2286mm)	TARX-3690-	S	DN7A	2635.05	2989.13	2758.28	3112.36	3296.70	3713.78	3359.64	3794.36	
	60"(1524mm)	TARX-3696-	S	DN7A	2710.59	3079.55	2841.98	3210.94	3419.34	3854.30	3488.16	3941.60	
	42"(1067mm)	60"(1524mm)	TARX-4260-	S	DN7A	\$2380.85	\$2675.41	\$2476.88	\$2771.44	\$2881.66	\$3227.22	\$2924.68	\$3284.52
		66"(1676mm)	TARX-4266-	S	DN7A	2468.38	2777.82	2573.93	2883.37	3023.18	3386.62	3072.98	3451.54
		72"(1829mm)	TARX-4272-	S	DN7A	2555.91	2880.23	2670.98	2995.30	3164.70	3546.02	3221.28	3618.56
		78"(1981mm)	TARX-4278-	S	DN7A	2643.44	2982.64	2768.03	3107.23	3306.22	3705.42	3369.58	3785.58
		84"(2134mm)	TARX-4284-	S	DN7A	2730.97	3085.05	2865.08	3219.16	3447.74	3864.82	3517.88	3952.60
		90"(2286mm)	TARX-4290-	S	DN7A	2818.50	3187.46	2962.13	3331.09	3589.26	4024.22	3666.18	4119.62
48"(1219mm)	60"(1524mm)	TARX-4296-	S	DN7A	2906.03	3289.87	3059.18	3443.02	3730.78	4183.62	3814.48	4286.64	
	66"(1676mm)	TARX-4860-	S	DN7A	\$2504.35	\$2813.79	\$2613.98	\$2923.42	\$3079.82	\$3443.26	\$3132.32	\$3510.88	
	72"(1829mm)	TARX-4866-	S	DN7A	2603.87	2928.19	2724.38	3048.70	3240.22	3621.54	3300.40	3697.68	
	78"(1981mm)	TARX-4872-	S	DN7A	2703.39	3042.59	2834.78	3173.98	3400.62	3799.82	3468.48	3884.48	
	84"(2134mm)	TARX-4878-	S	DN7A	2802.91	3156.99	2945.18	3299.26	3561.02	3978.10	3636.56	4071.28	
	90"(2286mm)	TARX-4884-	S	DN7A	2902.43	3271.39	3055.58	3424.54	3721.42	4156.38	3804.64	4258.08	
60"(1524mm)	TARX-4890-	S	DN7A	3001.95	3385.79	3165.98	3549.82	3881.82	4334.66	3972.72	4444.88		
66"(1676mm)	TARX-4896-	S	DN7A	3101.47	3500.19	3276.38	3675.10	4042.22	4512.94	4140.80	4631.68		

Planes Tables — Dual Disc Base

Laminate or Wood – Pebble

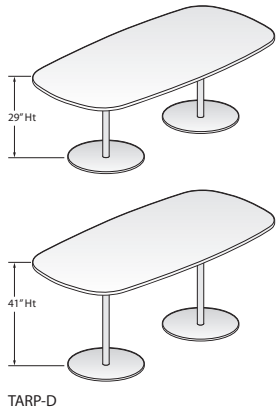

Features

- Laminate top with knife edge or 3mm edgeband edges or wood veneer top with 3mm wood edgeband or knife edge. Edgeband tops are 3mm on user edge and 1mm on remaining edges.
- Includes 1 3/16" (30mm) thick standard top, bases and hardware.
- Fixed table height options are 29" (737mm) and 41" (1041mm).
- Power modules are available for field installation; separately specified. Refer to Specification Guide.
- Ships unassembled.

Specification Tips

- Cutouts are designed for single sided flip top units and select workware connect interface modules (see workware price list).
- The following Planes products are separately specified:
 - Power modules
 - Grommet (field cut opening)
 - Wire Management

To Order, Specify:

1) Product number, including:

① Surface Options:

- L** Laminate
- W** Wood

② Edge Options:

Laminate:

- J** Edgeband
- F** Knife

Wood:

- K** Edgeband
- U** Knife

③ Cutout:

- N** No Cutout
- F** Center, Single-Sided/4 outlets, add **\$33.13** list
- J** Center, Single-Sided/6 outlets, add **\$33.13** list

2) Laminate surface color or wood finish color.

3) Edge trim color (laminated only).

4) Base trim color.

Note: **\$45.78** upcharge list for Metallic and accent trim colors.

Planes Tables — Dual Disc Base

Laminate or Wood — Pebble

Height	Depth	Width	Number ① ② ③	Laminate A		Laminate B		Wood Group A		Wood Group B	
				J	F	J	F	K	U	K	U
29"(737mm)	30"(762mm)	60"(1524mm)	TARP-3060-■ ■ S DN4A	\$2067.01	\$2290.21	\$2135.84	\$2359.04	\$2418.50	\$2686.70	\$2442.56	\$2723.36
		66"(1676mm)	TARP-3066-■ ■ S DN4A	2130.56	2368.64	2206.19	2444.27	2522.26	2808.34	2551.30	2850.82
		72"(1829mm)	TARP-3072-■ ■ S DN4A	2194.11	2447.07	2276.54	2529.50	2626.02	2929.98	2660.04	2978.28
		78"(1981mm)	TARP-3078-■ ■ S DN4A	2257.66	2525.50	2346.89	2614.73	2729.78	3051.62	2768.78	3105.74
		84"(2134mm)	TARP-3084-■ ■ S DN4A	2321.21	2603.93	2417.24	2699.96	2833.54	3173.26	2877.52	3233.20
		90"(2286mm)	TARP-3090-■ ■ S DN4A	2384.76	2682.36	2487.59	2785.19	2937.30	3294.90	2986.26	3360.66
	36"(914mm)	60"(1524mm)	TARP-3096-■ ■ S DN4A	2448.31	2760.79	2557.94	2870.42	3041.06	3416.54	3095.00	3488.12
		66"(1676mm)	TARP-3660-■ ■ S DN4A	\$2190.51	\$2428.59	\$2272.94	\$2511.02	\$2616.66	\$2902.74	\$2650.20	\$2949.72
		72"(1829mm)	TARP-3666-■ ■ S DN4A	2266.05	2519.01	2356.64	2609.60	2739.30	3043.26	2778.72	3096.96
		78"(1981mm)	TARP-3672-■ ■ S DN4A	2341.59	2609.43	2440.34	2708.18	2861.94	3183.78	2907.24	3244.20
		84"(2134mm)	TARP-3678-■ ■ S DN4A	2417.13	2699.85	2524.04	2806.76	2984.58	3324.30	3035.76	3391.44
		90"(2286mm)	TARP-3684-■ ■ S DN4A	2492.67	2790.27	2607.74	2905.34	3107.22	3464.82	3164.28	3538.68
	42"(1067mm)	60"(1524mm)	TARP-3690-■ ■ S DN4A	2568.21	2880.69	2691.44	3003.92	3229.86	3605.34	3292.80	3685.92
		66"(1676mm)	TARP-3696-■ ■ S DN4A	2643.75	2971.11	2775.14	3102.50	3352.50	3745.86	3421.32	3833.16
		72"(1829mm)	TARP-4260-■ ■ S DN4A	\$2314.01	\$2566.97	\$2410.04	\$2663.00	\$2814.82	\$3118.78	\$2857.84	\$3176.08
		78"(1981mm)	TARP-4266-■ ■ S DN4A	2401.54	2669.38	2507.09	2774.93	2956.34	3278.18	3006.14	3343.10
		84"(2134mm)	TARP-4272-■ ■ S DN4A	2489.07	2771.79	2604.14	2886.86	3097.86	3437.58	3154.44	3510.12
		90"(2286mm)	TARP-4278-■ ■ S DN4A	2576.60	2874.20	2701.19	2998.79	3239.38	3596.98	3302.74	3677.14
48"(1219mm)	60"(1524mm)	TARP-4284-■ ■ S DN4A	2664.13	2976.61	2798.24	3110.72	3380.90	3756.38	3451.04	3844.16	
	66"(1676mm)	TARP-4290-■ ■ S DN4A	2751.66	3079.02	2895.29	3222.65	3522.42	3915.78	3599.34	4011.18	
	72"(1829mm)	TARP-4296-■ ■ S DN4A	2839.19	3181.43	2992.34	3334.58	3663.94	4075.18	3747.64	4178.20	
	78"(1981mm)	TARP-4860-■ ■ S DN4A	\$2437.51	\$2705.35	\$2547.14	\$2814.98	\$3012.98	\$3334.82	\$3065.48	\$3402.44	
	84"(2134mm)	TARP-4866-■ ■ S DN4A	2537.03	2819.75	2657.54	2940.26	3173.38	3513.10	3233.56	3589.24	
	90"(2286mm)	TARP-4872-■ ■ S DN4A	2636.55	2934.15	2767.94	3065.54	3333.78	3691.38	3401.64	3776.04	
40"(1016mm)	30"(762mm)	60"(1524mm)	TARP-4878-■ ■ S DN4A	2736.07	3048.55	2878.34	3190.82	3494.18	3869.66	3569.72	3962.84
		66"(1676mm)	TARP-4884-■ ■ S DN4A	2835.59	3162.95	2988.74	3316.10	3654.58	4047.94	3737.80	4149.64
		72"(1829mm)	TARP-4890-■ ■ S DN4A	2935.11	3277.35	3099.14	3441.38	3814.98	4226.22	3905.88	4336.44
		78"(1981mm)	TARP-4896-■ ■ S DN4A	3034.63	3391.75	3209.54	3566.66	3975.38	4404.50	4073.96	4523.24
		84"(2134mm)	TARP-3060-■ ■ S DN7A	\$2133.85	\$2357.05	\$2202.68	\$2425.88	\$2485.34	\$2753.54	\$2509.40	\$2790.20
		90"(2286mm)	TARP-3066-■ ■ S DN7A	2197.40	2435.48	2273.03	2511.11	2589.10	2875.18	2618.14	2917.66
	36"(914mm)	60"(1524mm)	TARP-3072-■ ■ S DN7A	2260.95	2513.91	2343.38	2596.34	2692.86	2996.82	2726.88	3045.12
		66"(1676mm)	TARP-3078-■ ■ S DN7A	2324.50	2592.34	2413.73	2681.57	2796.62	3118.46	2835.62	3172.58
		72"(1829mm)	TARP-3084-■ ■ S DN7A	2388.05	2670.77	2484.08	2766.80	2900.38	3240.10	2944.36	3300.04
		78"(1981mm)	TARP-3090-■ ■ S DN7A	2451.60	2749.20	2554.43	2852.03	3004.14	3361.74	3053.10	3427.50
		84"(2134mm)	TARP-3096-■ ■ S DN7A	2515.15	2827.63	2624.78	2937.26	3107.90	3483.38	3161.84	3554.96
		90"(2286mm)	TARP-3660-■ ■ S DN7A	\$2257.35	\$2495.43	\$2339.78	\$2577.86	\$2683.50	\$2969.58	\$2717.04	\$3016.56
	42"(1067mm)	60"(1524mm)	TARP-3666-■ ■ S DN7A	2332.89	2585.85	2423.48	2676.44	2806.14	3110.10	2845.56	3163.80
		66"(1676mm)	TARP-3672-■ ■ S DN7A	2408.43	2676.27	2507.18	2775.02	2928.78	3250.62	2974.08	3311.04
		72"(1829mm)	TARP-3678-■ ■ S DN7A	2483.97	2766.69	2590.88	2873.60	3051.42	3391.14	3102.60	3458.28
		78"(1981mm)	TARP-3684-■ ■ S DN7A	2559.51	2857.11	2674.58	2972.18	3174.06	3531.66	3231.12	3605.52
		84"(2134mm)	TARP-3690-■ ■ S DN7A	2635.05	2947.53	2758.28	3070.76	3296.70	3672.18	3359.64	3752.76
		90"(2286mm)	TARP-3696-■ ■ S DN7A	2710.59	3037.95	2841.98	3169.34	3419.34	3812.70	3488.16	3900.00
48"(1219mm)	60"(1524mm)	TARP-4260-■ ■ S DN7A	\$2380.85	\$2633.81	\$2476.88	\$2729.84	\$2881.66	\$3185.62	\$2924.68	\$3242.92	
	66"(1676mm)	TARP-4266-■ ■ S DN7A	2468.38	2736.22	2573.93	2841.77	3023.18	3345.02	3072.98	3409.94	
	72"(1829mm)	TARP-4272-■ ■ S DN7A	2555.91	2838.63	2670.98	2953.70	3164.70	3504.42	3221.28	3576.96	
	78"(1981mm)	TARP-4278-■ ■ S DN7A	2643.44	2941.04	2768.03	3065.63	3306.22	3663.82	3369.58	3743.98	
	84"(2134mm)	TARP-4284-■ ■ S DN7A	2730.97	3043.45	2865.08	3177.56	3447.74	3823.22	3517.88	3911.00	
	90"(2286mm)	TARP-4290-■ ■ S DN7A	2818.50	3145.86	2962.13	3289.49	3589.26	3982.62	3666.18	4078.02	
48"(1219mm)	60"(1524mm)	TARP-4296-■ ■ S DN7A	2906.03	3248.27	3059.18	3401.42	3730.78	4142.02	3814.48	4245.04	
	66"(1676mm)	TARP-4860-■ ■ S DN7A	\$2504.35	\$2772.19	\$2613.98	\$2881.82	\$3079.82	\$3401.66	\$3132.32	\$3469.28	
	72"(1829mm)	TARP-4866-■ ■ S DN7A	2603.87	2886.59	2724.38	3007.10	3240.22	3579.94	3300.40	3656.08	
	78"(1981mm)	TARP-4872-■ ■ S DN7A	2703.39	3000.99	2834.78	3132.38	3400.62	3758.22	3468.48	3842.88	
	84"(2134mm)	TARP-4878-■ ■ S DN7A	2802.91	3115.39	2945.18	3257.66	3561.02	3936.50	3636.56	4029.68	
	90"(2286mm)	TARP-4884-■ ■ S DN7A	2902.43	3229.79	3055.58	3382.94	3721.42	4114.78	3804.64	4216.48	
48"(1219mm)	60"(1524mm)	TARP-4890-■ ■ S DN7A	3001.95	3344.19	3165.98	3508.22	3881.82	4293.06	3972.72	4403.28	
	66"(1676mm)	TARP-4896-■ ■ S DN7A	3101.47	3458.59	3276.38	3633.50	4042.22	4471.34	4140.80	4590.08	

Planes Training Tables

Terminology

Flip Top Table

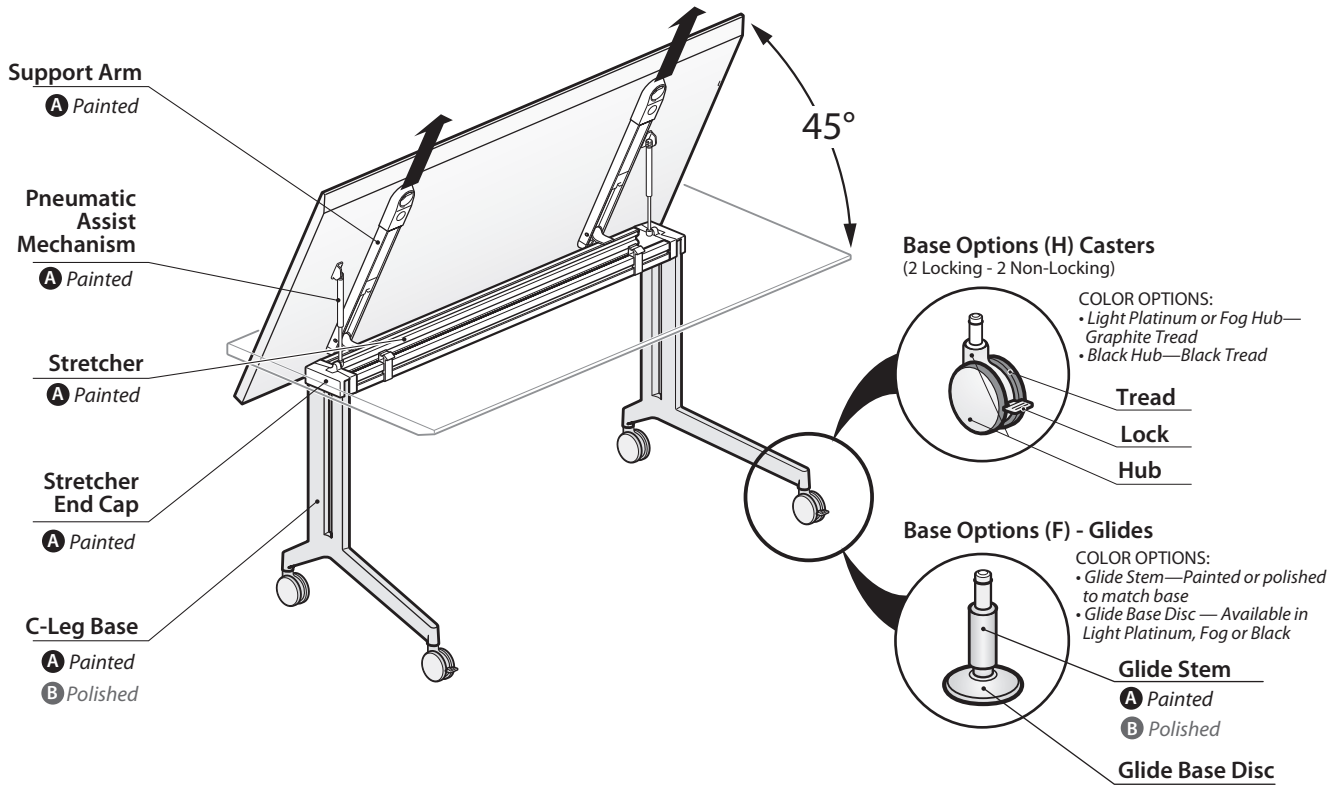

Non-Flip Top Table

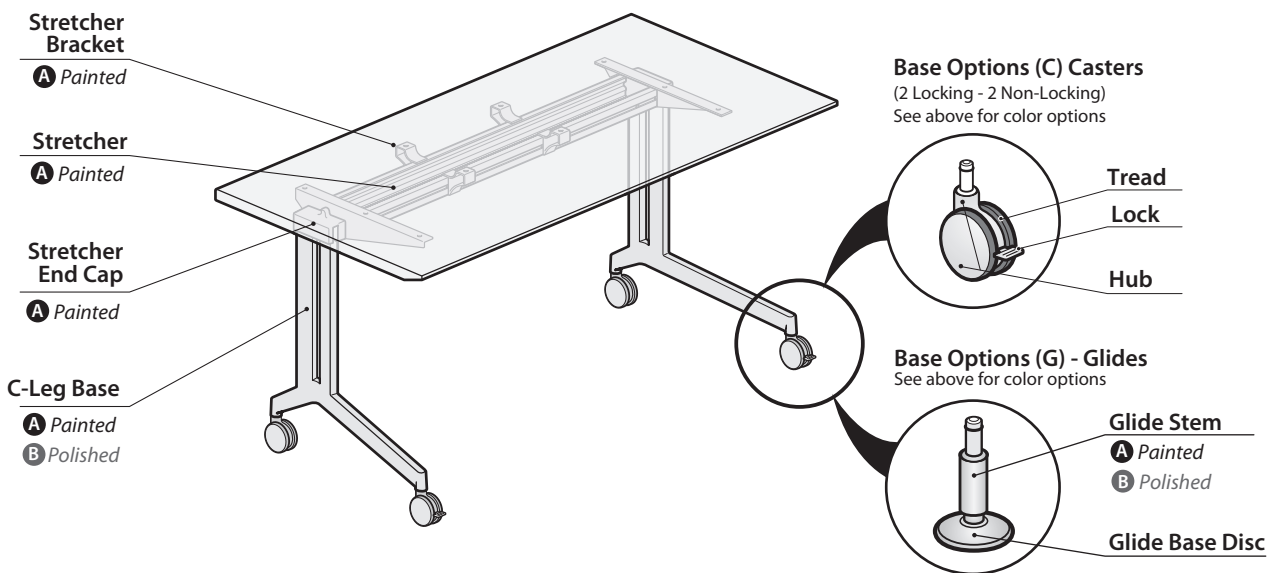

Planes Training Tables

Product Catalog Logic

EXAMPLE: Planes C-Leg Training Table, flip top, rectangular, 24" deep by 60" wide, wood with 3mm wood edgeband, standard core, no cutouts for Flip Top Unit, C-Leg, flip top with casters, 29" high, Painted base/stretcher finish option.

TARA-24 60-W K S N CH 4 A

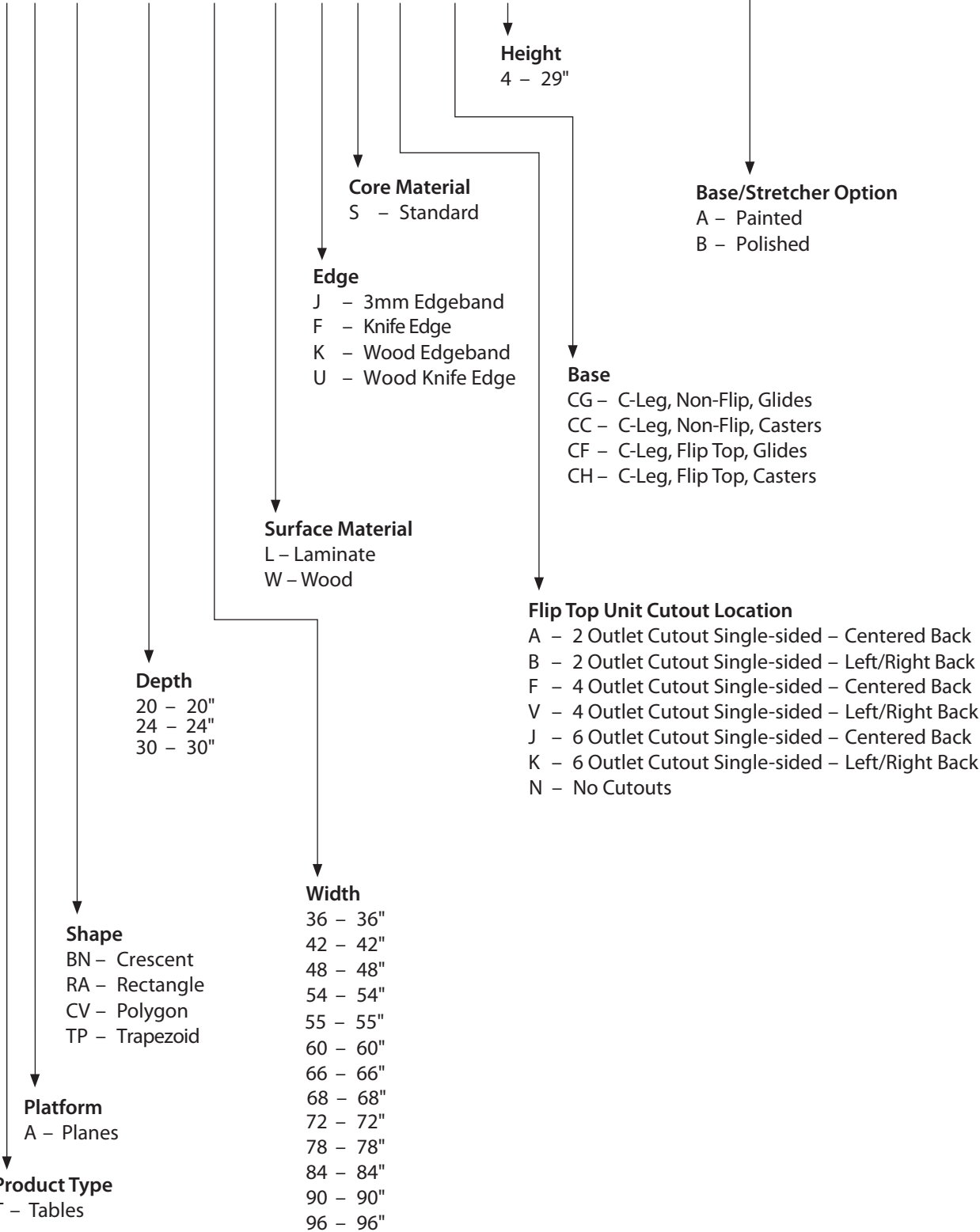

Planes Training Tables — Rectangular — Laminate

Flip Top or Non-Flip Top Table

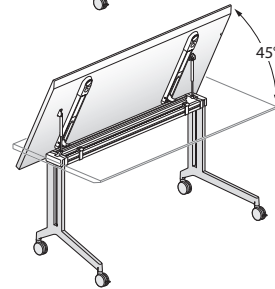
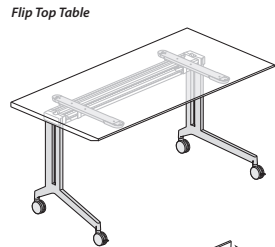
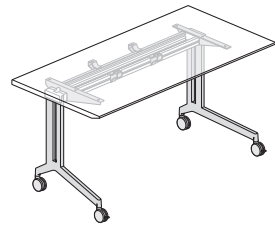
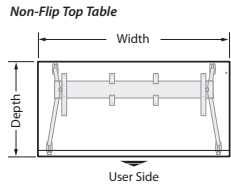

TARA-L



Features

- Includes 1-3/16"(30mm) thick top, two C-Leg bases, stretcher and hardware.
- Standard table height is 29"(737mm).
- Laminate top with 3mm edgeband on user edge and 1mm edgeband on remaining sides, or knife edge on user edge and 1mm edgeband on sides and back.
- Base Options:
 - Flip Top Table with casters (H) or with glides (F).
 - Non-flip Top Table with casters (C) or with glides (G).
- Flip Top Table:
 - Table top flips from horizontal to vertical position via pneumatic assist mechanism activated by two finger pulls.
 - Tables nest when flipped to vertical position. Refer to Specification Guide for details.
- Base and Stretcher Finish Options:
 - (A) Painted aluminum C-leg bases, glide stem and stretcher. Stretcher end caps and support arms or stretcher brackets match base trim color. (Specify trim color)
 - (B) Polished aluminum C-leg bases and glide stem. Stretcher and support arms or stretcher brackets are painted and require a trim color specification.
- Flip Top Unit Cutout Options include:
 - One cutout centered along back edge, or
 - One left and one right cutout along back edge.
- Optional casters or glides are field interchangeable:
 - Casters (two locking/two non-locking) are available with: Light platinum or fog hub with graphite tread, or black hub with black tread.
- Optional glides (four) are available in light platinum, fog or black with 1/2"(13mm) height adjustment.
 - Glide stem is painted or polished to match base; glide base disc color must be specified.
- Depth and width shown in nominal dimensions.
- Ships unassembled.

Specification Tip

- The following Planes products are separately specified:
 - Ganging Mechanism - Required for use with powered tables.
 - Flip Top Unit electrical modules
 - Electrical Components
 - Grommet (field cut opening)
 - Modesty Panel
 - Vertical Wire Manager
 - Horizontal Wire Manager
 - Wire Management Clips

To Order, Specify:

1) Product number, including:

1 Edge Options:

- J** Edgeband
- F** Knife

2 Flip Top Unit Cutout Options by Width:

36" - 54" (Options: A, F, J, N)
60" - 96" (Options: A, B, F, V, J, K, N)

- N** No cutout
- A** 2 outlet cutout - centered back, add **\$33.13** list
- B** 2 outlet cutout - left and right back, add **\$66.26** list
- F** 4 outlet cutout - centered back, add **\$33.13** list
- V** 4 outlet cutout - left and right back, add **\$66.26** list
- J** 6 outlet cutout - centered back, add **\$33.13** list
- K** 6 outlet cutout - left and right back, add **\$66.26** list

3 Base Options (Flip/Non-Flip):

- H** Flip Top Table: Casters, add **\$136.80** list
- F** Flip Top Table: Glides, add **\$214.80** list
- C** Non-flip Top Table: Casters
- G** Non-flip Top Table: Glides, add **\$78.00** list

4 Base/Stretcher Finish Options:

- A** Painted
- B** Polished, add **\$542.24** (must specify trim color for stretcher)

- 2) Laminate surface color.
- 3) Edge trim color.
- 4) Base/Stretcher trim color.
- 5) Caster/Glide Base Disc trim color.

Note: **\$45.78** upcharge list for Metallic and accent trim colors.

Planes Training Tables — Rectangular — Laminate

Flip Top or Non-Flip Top Table

Depth	Width	Laminate Number	① ② ③ ④				Laminate A		Laminate B	
			J	F	J	F				
Flip Top Tables										
24"(610mm)	36"(914mm)	TARA-2436-L	S	C	4	\$ 820.45	\$1004.85	\$ 853.38	\$1037.78	
	42"(1067mm)	TARA-2442-L	S	C	4	952.01	1150.69	990.34	1189.02	
	48"(1219mm)	TARA-2448-L	S	C	4	1083.57	1296.53	1127.30	1340.26	
	54"(1372mm)	TARA-2454-L	S	C	4	1215.13	1442.37	1264.26	1491.50	
	60"(1524mm)	TARA-2460-L	S	C	4	1346.69	1588.21	1401.22	1642.74	
	66"(1676mm)	TARA-2466-L	S	C	4	1478.25	1734.05	1538.18	1793.98	
	72"(1829mm)	TARA-2472-L	S	C	4	1609.81	1879.89	1675.14	1945.22	
30"(762mm)	36"(914mm)	TARA-3036-L	S	C	4	\$ 932.12	\$1130.80	\$ 973.15	\$1171.83	
	42"(1067mm)	TARA-3042-L	S	C	4	1071.81	1284.77	1119.59	1332.55	
	48"(1219mm)	TARA-3048-L	S	C	4	1211.50	1438.74	1266.03	1493.27	
	54"(1372mm)	TARA-3054-L	S	C	4	1351.19	1592.71	1412.47	1653.99	
	60"(1524mm)	TARA-3060-L	S	C	4	1490.88	1746.68	1558.91	1814.71	
	66"(1676mm)	TARA-3066-L	S	C	4	1630.57	1900.65	1705.35	1975.43	
	72"(1829mm)	TARA-3072-L	S	C	4	1770.26	2054.62	1851.79	2136.15	
Non-Flip Top Tables										
20"(508mm)	36"(914mm)	TARA-2036-L	S	C	4	\$ 786.17	\$ 961.05	\$ 813.70	\$ 988.58	
	42"(1067mm)	TARA-2042-L	S	C	4	909.60	1098.76	941.18	1130.34	
	48"(1219mm)	TARA-2048-L	S	C	4	1041.16	1244.60	1078.14	1281.58	
	54"(1372mm)	TARA-2054-L	S	C	4	1164.59	1382.31	1205.62	1423.34	
	60"(1524mm)	TARA-2060-L	S	C	4	1288.02	1520.02	1333.10	1565.10	
	66"(1676mm)	TARA-2066-L	S	C	4	1419.58	1665.86	1470.06	1716.34	
	72"(1829mm)	TARA-2072-L	S	C	4	1543.01	1803.57	1597.54	1858.10	
	78"(1981mm)	TARA-2078-L	S	C	4	1713.43	1988.27	1772.01	2046.85	
	84"(2134mm)	TARA-2084-L	S	C	4	1852.22	2141.34	1916.20	2205.32	
	90"(2286mm)	TARA-2090-L	S	C	4	1982.88	2286.28	2050.91	2354.31	
96"(2438mm)	TARA-2096-L	S	C	4	2113.54	2431.22	2185.62	2503.30		
24"(610mm)	36"(914mm)	TARA-2436-L	S	C	4	\$ 820.45	\$1004.85	\$ 853.38	\$1037.78	
	42"(1067mm)	TARA-2442-L	S	C	4	952.01	1150.69	990.34	1189.02	
	48"(1219mm)	TARA-2448-L	S	C	4	1083.57	1296.53	1127.30	1340.26	
	54"(1372mm)	TARA-2454-L	S	C	4	1215.13	1442.37	1264.26	1491.50	
	60"(1524mm)	TARA-2460-L	S	C	4	1346.69	1588.21	1401.22	1642.74	
	66"(1676mm)	TARA-2466-L	S	C	4	1478.25	1734.05	1538.18	1793.98	
	72"(1829mm)	TARA-2472-L	S	C	4	1609.81	1879.89	1675.14	1945.22	
	78"(1981mm)	TARA-2478-L	S	C	4	1788.36	2072.72	1859.09	2143.45	
	84"(2134mm)	TARA-2484-L	S	C	4	1927.15	2225.79	2003.28	2301.92	
	90"(2286mm)	TARA-2490-L	S	C	4	2065.94	2378.86	2147.47	2460.39	
	96"(2438mm)	TARA-2496-L	S	C	4	2204.73	2531.93	2291.66	2618.86	
	30"(762mm)	36"(914mm)	TARA-3036-L	S	C	4	\$ 932.12	\$1130.80	\$ 973.15	\$1171.83
		42"(1067mm)	TARA-3042-L	S	C	4	1071.81	1284.77	1119.59	1332.55
48"(1219mm)		TARA-3048-L	S	C	4	1211.50	1438.74	1266.03	1493.27	
54"(1372mm)		TARA-3054-L	S	C	4	1351.19	1592.71	1412.47	1653.99	
60"(1524mm)		TARA-3060-L	S	C	4	1490.88	1746.68	1558.91	1814.71	
66"(1676mm)		TARA-3066-L	S	C	4	1630.57	1900.65	1705.35	1975.43	
72"(1829mm)		TARA-3072-L	S	C	4	1770.26	2054.62	1851.79	2136.15	
78"(1981mm)		TARA-3078-L	S	C	4	1956.94	2255.58	2045.22	2343.86	
84"(2134mm)		TARA-3084-L	S	C	4	2103.86	2416.78	2198.89	2511.81	
90"(2286mm)		TARA-3090-L	S	C	4	2250.78	2577.98	2352.56	2679.76	
96"(2438mm)		TARA-3096-L	S	C	4	2397.70	2739.18	2506.23	2847.71	

Planes Training Tables — Crescent — Laminate

Flip Top or Non-Flip Top Table

Depth	Width	Laminate Number				Laminate A		Laminate B	
		1	2	3	4	J	F	J	F
30"(762mm)	68"(1727mm)	TABN-3068-L	S	C	4	\$1608.35	\$1883.19	\$1685.30	\$1960.14

Non-Flip Top Table

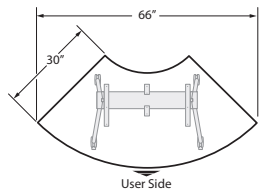

Flip Top Table

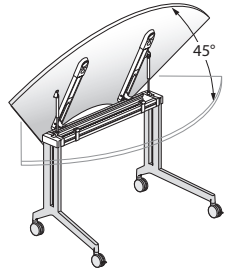
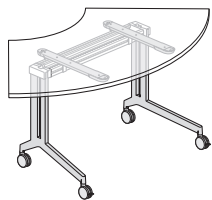

TABN-L



Features

- Includes 1-3/16"(30mm) thick top, two C-Leg bases, stretcher and hardware.
- Standard table height is 29"(737mm).
- Laminate top with 3mm edgeband on user edge and 1mm edgeband on remaining sides, or knife edge on user edge and 1mm edgeband on sides and back.
- Base Options:
 - Flip Top Table with casters (H) or with glides (F).
 - Non-flip Top Table with casters (C) or with glides (G).
- Flip Top Table:
 - Table top flips from horizontal to vertical position via pneumatic assist mechanism activated by two finger pulls.
 - Tables nest when flipped to vertical position. Refer to Specification Guide for details.
- Base and Stretcher Finish Options:
 - (A) Painted aluminum C-leg bases, glide stem and stretcher. Stretcher end caps and support arms or stretcher brackets match base trim color. (Specify trim color)
 - (B) Polished aluminum C-leg bases and glide stem. Stretcher and support arms or stretcher brackets are painted and require a trim color specification.
- Flip Top Unit Cutout Options include:
 - One cutout centered along back edge.
- Optional casters or glides are field interchangeable:
 - Casters (two locking/two non-locking) are available with: Light platinum or fog hub with graphite tread, or black hub with black tread.
- Optional glides (four) are available in light platinum, fog or black with 1/2"(13mm) height adjustment.
 - Glide stem is painted or polished to match base; glide base disc color must be specified.
- Depth and width shown in nominal dimensions.
- Ships unassembled.

Specification Tip

- The following Planes products are separately specified:
 - Ganging Mechanism - Required for use with powered tables.
 - Flip Top Unit electrical modules
 - Electrical Components
 - Grommet (field cut opening)
 - Vertical Wire Manager
 - Horizontal Wire Manager
 - Wire Management Clips

To Order, Specify:

1) Product number, including:

1 Edge Options:

- J** Edgeband
- F** Knife

2 Flip Top Unit Cutout Options:

- N** No cutout
- A** 2 outlet cutout - centered back, add \$33.13 list
- F** 4 outlet cutout - centered back, add \$33.13 list
- J** 6 outlet cutout - centered back, add \$33.13 list

3 Base Options (Flip/Non-Flip):

- H** Flip Top Table: Casters, add \$136.80 list
- F** Flip Top Table: Glides, add \$214.80 list
- C** Non-flip Top Table: Casters
- G** Non-flip Top Table: Glides, add \$78.00 list

4 Base/Stretcher Finish Options:

- A** Painted
- B** Polished, add \$542.24 (must specify trim color for stretcher)

- 2) Laminate surface color.
- 3) Edge trim color.
- 4) Base/Stretcher trim color.
- 5) Caster/Glide Base Disc trim color.

Note: \$45.78 upcharge list for Metallic and accent trim colors.

Planes Training Tables — Trapezoid — Laminate

Flip Top or Non-Flip Top Table

Depth	Width	Number ① ② ③ ④	Laminate A		Laminate B	
			J	F	J	F
30" (762mm)	60" (1524mm)	TATP-3060-L S C 4	\$1489.16	\$1744.96	\$1557.99	\$1813.79

Non-Flip Top Table

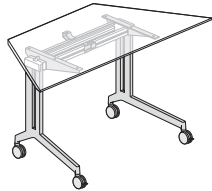
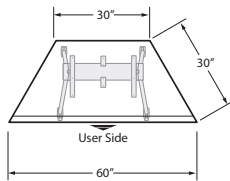

Flip Top Table

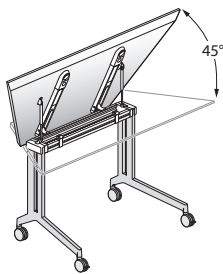
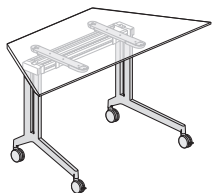

TATP-L

**Features**

- Includes 1-3/16" (30mm) thick top, two C-Leg bases, stretcher and hardware.
- Standard table height is 29" (737mm).
- Laminate top with 3mm edgeband on user edge and 1mm edgeband on remaining sides, or knife edge on user edge and 1mm edgeband on sides and back.
- Base Options:
 - Flip Top Table with casters (H) or with glides (F).
 - Non-flip Top Table with casters (C) or with glides (G).
- Flip Top Table:
 - Table top flips from horizontal to vertical position via pneumatic assist mechanism activated by two finger pulls.
 - Tables nest when flipped to vertical position. Refer to Specification Guide for details.
- Base and Stretcher Finish Options:
 - (A) Painted aluminum C-leg bases, glide stem and stretcher. Stretcher end caps and support arms or stretcher brackets match base trim color. (Specify trim color)
 - (B) Polished aluminum C-leg bases and glide stem. Stretcher and support arms or stretcher brackets are painted and require a trim color specification.
- Flip Top Unit Cutout Options include:
 - One cutout centered along back edge.
- Optional casters or glides are field interchangeable:
 - Casters (two locking/two non-locking) are available with: Light platinum or fog hub with graphite tread, or black hub with black tread.
- Optional glides (four) are available in light platinum, fog or black with 1/2" (13mm) height adjustment.
 - Glide stem is painted or polished to match base; glide base disc color must be specified.
- Depth and width shown in nominal dimensions.
- Ships unassembled.

Specification Tip

- The following Planes products are separately specified:
 - Ganging Mechanism - Required for use with powered tables.
 - Flip Top Unit electrical modules
 - Electrical Components
 - Grommet (field cut opening)
 - Modesty Panel
 - Vertical Wire Manager
 - Horizontal Wire Manager
 - Wire Management Clips

To Order, Specify:

1) Product number, including:

① Edge Options:

- J** Edgeband
- F** Knife

② Flip Top Unit Cutout Options:

- N** No cutout
- A** 2 outlet cutout - centered back, add **\$33.13** list
- F** 4 outlet cutout - centered back, add **\$33.13** list
- J** 6 outlet cutout - centered back, add **\$33.13** list

③ Base Options (Flip/Non-Flip):

- H** Flip Top Table: Casters, add **\$136.80** list
- F** Flip Top Table: Glides, add **\$214.80** list
- C** Non-flip Top Table: Casters
- G** Non-flip Top Table: Glides, add **\$78.00** list

④ Base/Stretcher Finish Options:

- A** Painted
- B** Polished, add **\$542.24** (must specify trim color for stretcher)

2) Laminate surface color.

3) Edge trim color.

4) Base/Stretcher trim color.

5) Caster/Glide Base Disc trim color.

Note: \$45.78 upcharge list for Metallic and accent trim colors.

Planes Training Tables — Polygon — Laminate

Flip Top or Non-Flip Top Table

Depth	Width	Number	① ② ③ ④				Laminate A		Laminate B	
			S	C	4		J	F	J	F
24"(610mm)	55"(1397mm)	TACV-2455-L	S	C	4		\$1256.77	\$1425.28	\$1377.26	\$1545.77
30"(762mm)	66"(1676mm)	TACV-3066-L	S	C	4		1583.34	1825.35	1703.83	1945.84

Non-Flip Top Table

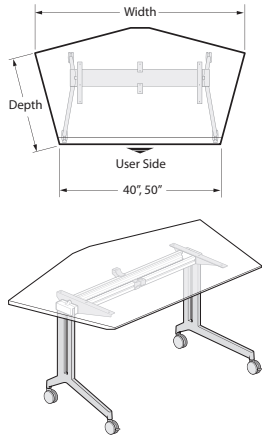

Flip Top Table

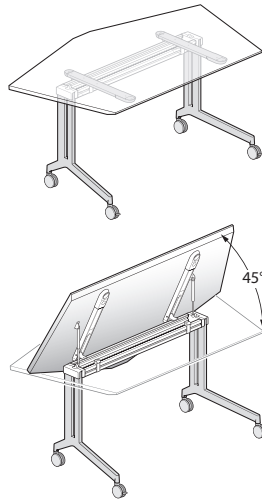

TACV-L



Features

- Includes 1-3/16"(30mm) thick top, two C-Leg bases, stretcher and hardware.
- Standard table height is 29"(737mm).
- Laminate top with 3mm edgeband on user edge and 1mm edgeband on remaining sides, or knife edge on user edge and 1mm edgeband on sides and back.
- Base Options:
 - Flip Top Table with casters (H) or with glides (F).
 - Non-flip Top Table with casters (C) or with glides (G).
- Flip Top Table:
 - Table top flips from horizontal to vertical position via pneumatic assist mechanism activated by two finger pulls.
 - Tables nest when flipped to vertical position. Refer to Specification Guide for details.
- Base and Stretcher Finish Options:
 - (A) Painted aluminum C-leg bases, glide stem and stretcher. Stretcher end caps and support arms or stretcher brackets match base trim color. (Specify trim color)
 - (B) Polished aluminum C-leg bases and glide stem. Stretcher and support arms or stretcher brackets are painted and require a trim color specification.
- Flip Top Unit Cutout Options include:
 - One cutout centered along back edge.
- Optional casters or glides are field interchangeable:
 - Casters (two locking/two non-locking) are available with: Light platinum or fog hub with graphite tread, or black hub with black tread.
- Optional glides (four) are available in light platinum, fog or black with 1/2"(13mm) height adjustment.
 - Glide stem is painted or polished to match base; glide base disc color must be specified.
- Depth and width shown in nominal dimensions.
- Ships unassembled.

Specification Tip

- The following Planes products are separately specified:
 - Ganging Mechanism - Required for use with powered tables.
 - Flip Top Unit electrical modules
 - Electrical Components
 - Grommet (field cut opening)
 - Modesty Panel
 - Vertical Wire Manager
 - Horizontal Wire Manager
 - Wire Management Clips

To Order, Specify:

1) Product number, including:

① Edge Options:

- J** Edgeband
- F** Knife

② Flip Top Unit Cutout Options:

- N** No cutout
- A** 2 outlet cutout - centered back, add \$33.13 list
- F** 4 outlet cutout - centered back, add \$33.13 list
- J** 6 outlet cutout - centered back, add \$33.13 list

③ Base Options (Flip/Non-Flip):

- H** Flip Top Table: Casters, add \$136.80 list
- F** Flip Top Table: Glides, add \$214.80 list
- C** Non-flip Top Table: Casters
- G** Non-flip Top Table: Glides

④ Base/Stretcher Finish Options:

- A** Painted
- B** Polished, add \$542.24 (must specify trim color for stretcher)

- 2) Laminate surface color.
- 3) Edge trim color.
- 4) Base/Stretcher trim color.
- 5) Caster/Glide Base Disc trim color.

Note: \$45.78 upcharge list for Metallic and accent trim colors.

Planes Training Tables — Pie Connector — Laminate

Depth	Laminate Number ①	Laminate A		Laminate B	
		J	F	J	F
20"(508mm)	TAPC-2015-L SN	\$307.28	\$395.49	\$331.39	\$419.60
	TAPC-2030-L SN	331.39	419.60	355.50	443.71
	TAPC-2045-L SN	355.50	443.71	379.61	467.82
	TAPC-2090-L SN	403.72	491.93	427.83	516.04
24"(610mm)	TAPC-2415-L SN	\$379.59	\$467.80	\$403.70	\$491.91
	TAPC-2430-L SN	403.70	491.91	427.81	516.02
	TAPC-2445-L SN	427.81	516.02	451.92	540.13
	TAPC-2490-L SN	476.03	564.24	500.14	588.35
30"(762mm)	TAPC-3015-L SN	\$451.90	\$540.11	\$476.01	\$564.22
	TAPC-3030-L SN	476.01	564.22	500.12	588.33
	TAPC-3045-L SN	500.12	588.33	524.23	612.44
	TAPC-3090-L SN	548.34	636.55	572.45	660.66

Pie Connector

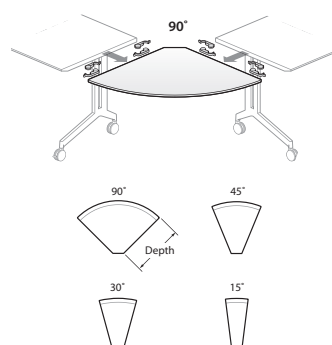

TAPC-L

Features

- Includes 1-3/16"(30mm) thick top and two sets of ganging mechanisms required for support.
- Laminate top with 3mm edgeband on user edge and 1mm edgeband on remaining sides, or knife edge on user edge and 1mm edgeband on sides and back.
- Depth shown in nominal dimensions.
- Ships unassembled.

Specification Tips

- Requires two same-depth Planes C-Leg Training Tables for support; separately specified.
- Additional Table Pass-Through Connector may be required based upon application.
- Wire Manager Clips are available if needed; separately specified.

To Order, Specify:

- 1) Product number, including:

① Edge Options:

- J Edgeband
- F Knife

- 2) Laminate surface color.

- 3) Edge trim color.

Planes Training Table — Rectangular — Wood

Flip Top or Non-Flip Top Table

Non-Flip Top Table

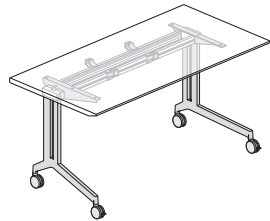
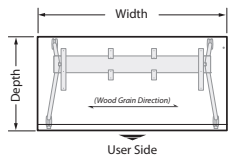

Flip Top Table

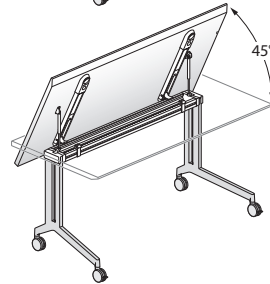
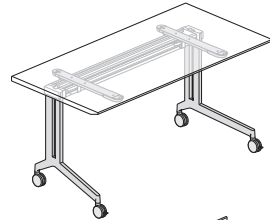

TARA-W



Features

- Includes 1-3/16" (30mm) thick top, two C-Leg bases, stretcher and hardware.
- Standard table height is 29" (737mm).
- Wood veneer top with 3mm edgeband on user edge and 1mm edgeband on remaining sides, or knife edge on user edge and 1mm edgeband on sides and back.
- Base Options:
 - Flip Top Table with casters (H) or with glides (F).
 - Non-flip Top Table with casters (C) or with glides (G).
- Flip Top Table:
 - Table top flips from horizontal to vertical position via pneumatic assist mechanism activated by two finger pulls.
 - Tables nest when flipped to vertical position. Refer to Specification Guide for details.
- Base and Stretcher Finish Options:
 - (A) Painted aluminum C-leg bases, glide stem and stretcher. Stretcher end caps and support arms or stretcher brackets match base trim color. (Specify trim color)
 - (B) Polished aluminum C-leg bases and glide stem. Stretcher and support arms or stretcher brackets are painted and require a trim color specification.
- Flip Top Unit Cutout Options include:
 - One cutout centered along back edge, or
 - One left and one right cutout along back edge.
- Optional casters or glides are field interchangeable:
 - Casters (two locking/two non-locking) are available with: Light platinum or fog hub with graphite tread, or black hub with black tread.
- Optional glides (four) are available in light platinum, fog or black with 1/2" (13mm) height adjustment.
 - Glide stem is painted or polished to match base; glide base disc color must be specified.
- Depth and width shown in nominal dimensions.
- Ships unassembled.

Specification Tip

- The following Planes products are separately specified:
 - Ganging Mechanism - Required for use with powered tables.
 - Flip Top Unit electrical modules
 - Electrical Components
 - Grommet (field cut opening)
 - Modesty Panel
 - Vertical Wire Manager
 - Horizontal Wire Manager
 - Wire Management Clips

To Order, Specify:

1) Product number, including:

1 Edge Options:

- K** Edgeband
- U** Knife

2 Flip Top Unit Cutout Options by Width:

36" - 54" (Options: A, F, J, N)
60" - 96" (Options: A, B, F, V, J, K, N)

- N** No cutout
- A** 2 outlet cutout - centered back, add **\$33.13** list
- B** 2 outlet cutout - left and right back, add **\$66.26** list
- F** 4 outlet cutout - centered back, add **\$33.13** list
- V** 4 outlet cutout - left and right back, add **\$66.26** list
- J** 6 outlet cutout - centered back, add **\$33.13** list
- K** 6 outlet cutout - left and right back, add **\$66.26** list

3 Base Options (Flip/Non-Flip):

- H** Flip Top Table: Casters, add **\$136.80** list
- F** Flip Top Table: Glides, add **\$214.80** list
- C** Non-flip Top Table: Casters
- G** Non-flip Top Table: Glides, add **\$75.00** list

4 Base/Stretcher Finish Options:

- A** Painted
- B** Polished, add **\$542.24** (must specify trim color for stretcher/arms)

- 2) Wood finish color.
- 3) Base/Stretcher trim color.
- 4) Caster/Glide Base Disc trim color.

Note: **\$45.78** upcharge list for Metallic and accent trim colors.

Planes Training Table — Rectangular — Wood

Flip Top or Non-Flip Top Table

Depth	Width	Number	① ② ③ ④				Wood Group A		Wood Group B	
			S	C	4		K	U	K	U
Flip Top Tables										
24"(610mm)	36"(914mm)	TARA-2436-W	S	C	4		\$1058.85	\$1234.85	\$1067.69	\$1271.29
	42"(1067mm)	TARA-2442-W	S	C	4		1211.73	1401.17	1222.93	1442.73
	48"(1219mm)	TARA-2448-W	S	C	4		1364.61	1567.49	1378.17	1614.17
	54"(1372mm)	TARA-2454-W	S	C	4		1517.49	1733.81	1533.41	1785.61
	60"(1524mm)	TARA-2460-W	S	C	4		1670.37	1900.13	1688.65	1957.05
	66"(1676mm)	TARA-2466-W	S	C	4		1823.25	2066.45	1843.89	2128.49
	72"(1829mm)	TARA-2472-W	S	C	4		1976.13	2232.77	1999.13	2299.93
	30"(762mm)	36"(914mm)	TARA-3036-W	S	C	4		\$1190.44	\$1379.88	\$1202.46
42"(1067mm)		TARA-3042-W	S	C	4		1350.75	1553.63	1365.54	1601.54
48"(1219mm)		TARA-3048-W	S	C	4		1511.06	1727.38	1528.62	1780.82
54"(1372mm)		TARA-3054-W	S	C	4		1671.37	1901.13	1691.70	1960.10
60"(1524mm)		TARA-3060-W	S	C	4		1831.68	2074.88	1854.78	2139.38
66"(1676mm)		TARA-3066-W	S	C	4		1991.99	2248.63	2017.86	2318.66
72"(1829mm)		TARA-3072-W	S	C	4		2152.30	2422.38	2180.94	2497.94
Non-Flip Top Tables										
20"(508mm)	36"(914mm)	TARA-2036-W	S	C	4		\$1011.29	\$1178.33	\$1018.01	\$1210.81
	42"(1067mm)	TARA-2042-W	S	C	4		1156.74	1337.22	1165.41	1374.41
	48"(1219mm)	TARA-2048-W	S	C	4		1309.62	1503.54	1320.65	1545.85
	54"(1372mm)	TARA-2054-W	S	C	4		1455.07	1662.43	1468.05	1709.45
	60"(1524mm)	TARA-2060-W	S	C	4		1600.52	1821.32	1615.45	1873.05
	66"(1676mm)	TARA-2066-W	S	C	4		1753.40	1987.64	1770.69	2044.49
	72"(1829mm)	TARA-2072-W	S	C	4		1898.85	2146.53	1918.09	2208.09
	78"(1981mm)	TARA-2078-W	S	C	4		2091.29	2352.41	2112.48	2418.68
	84"(2134mm)	TARA-2084-W	S	C	4		2251.40	2525.96	2274.95	2597.35
	90"(2286mm)	TARA-2090-W	S	C	4		2404.08	2692.08	2429.58	2768.18
24"(610mm)	36"(914mm)	TARA-2436-W	S	C	4		\$1058.85	\$1234.85	\$1067.69	\$1271.29
	42"(1067mm)	TARA-2442-W	S	C	4		1211.73	1401.17	1222.93	1442.73
	48"(1219mm)	TARA-2448-W	S	C	4		1364.61	1567.49	1378.17	1614.17
	54"(1372mm)	TARA-2454-W	S	C	4		1517.49	1733.81	1533.41	1785.61
	60"(1524mm)	TARA-2460-W	S	C	4		1670.37	1900.13	1688.65	1957.05
	66"(1676mm)	TARA-2466-W	S	C	4		1823.25	2066.45	1843.89	2128.49
	72"(1829mm)	TARA-2472-W	S	C	4		1976.13	2232.77	1999.13	2299.93
	78"(1981mm)	TARA-2478-W	S	C	4		2176.00	2446.08	2201.36	2518.36
	84"(2134mm)	TARA-2484-W	S	C	4		2336.11	2619.63	2363.83	2697.03
	90"(2286mm)	TARA-2490-W	S	C	4		2496.22	2793.18	2526.30	2875.70
30"(762mm)	36"(914mm)	TARA-3036-W	S	C	4		\$1190.44	\$1379.88	\$1202.46	\$1422.26
	42"(1067mm)	TARA-3042-W	S	C	4		1350.75	1553.63	1365.54	1601.54
	48"(1219mm)	TARA-3048-W	S	C	4		1511.06	1727.38	1528.62	1780.82
	54"(1372mm)	TARA-3054-W	S	C	4		1671.37	1901.13	1691.70	1960.10
	60"(1524mm)	TARA-3060-W	S	C	4		1831.68	2074.88	1854.78	2139.38
	66"(1676mm)	TARA-3066-W	S	C	4		1991.99	2248.63	2017.86	2318.66
	72"(1829mm)	TARA-3072-W	S	C	4		2152.30	2422.38	2180.94	2497.94
	78"(1981mm)	TARA-3078-W	S	C	4		2359.60	2643.12	2391.01	2724.21
	84"(2134mm)	TARA-3084-W	S	C	4		2527.14	2824.10	2561.32	2910.72
	90"(2286mm)	TARA-3090-W	S	C	4		2694.68	3005.08	2731.63	3097.23
96"(2438mm)	TARA-3096-W	S	C	4		2862.22	3186.06	2901.94	3283.74	

Planes Training Tables — Crescent — Wood

Flip Top or Non-Flip Top Table

Depth	Width	Number	①	②	③	④	Wood Group A K	U	Wood Group B K	U
30"(762mm)	68"(1727mm)	TABN-3068-W	S	C	4		\$2016.56	\$2277.68	\$2052.26	\$2358.46

Non-Flip Top Table

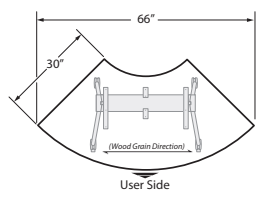

Flip Top Table

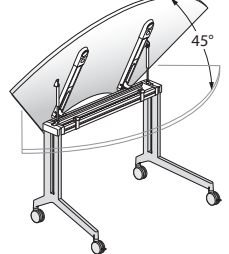
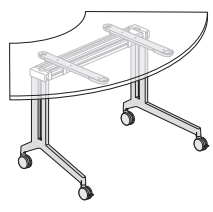

TABN-W



Features

- Includes 1-3/16"(30mm) thick top, two C-Leg bases, stretcher and hardware.
- Standard table height is 29"(737mm).
- Wood veneer top with 3mm edgeband on user edge and 1mm edgeband on remaining sides, or knife edge on user edge and 1mm edgeband on sides and back.
- Base Options:
 - Flip Top Table with casters (H) or with glides (F).
 - Non-flip Top Table with casters (C) or with glides (G).
- Flip Top Table:
 - Table top flips from horizontal to vertical position via pneumatic assist mechanism activated by two finger pulls.
 - Tables nest when flipped to vertical position. Refer to Specification Guide for details.
- Base and Stretcher Finish Options:
 - (A) Painted aluminum C-leg bases, glide stem and stretcher. Stretcher end caps and support arms or stretcher brackets match base trim color. (Specify trim color)
 - (B) Polished aluminum C-leg bases and glide stem. Stretcher and support arms or stretcher brackets are painted and require a trim color specification.
- Flip Top Unit Cutout Options include:
 - One cutout centered along back edge.
- Optional casters or glides are field interchangeable:
 - Casters (two locking/two non-locking) are available with: Light platinum or fog hub with graphite tread, or black hub with black tread.
- Optional glides (four) are available in light platinum, fog or black with 1/2"(13mm) height adjustment.
 - Glide stem is painted or polished to match base; glide base disc color must be specified.
- Depth and width shown in nominal dimensions.
- Ships unassembled.

Specification Tip

- The following Planes products are separately specified:
 - Ganging Mechanism - Required for use with powered tables.
 - Flip Top Unit electrical modules
 - Electrical Components
 - Grommet (field cut opening)
 - Vertical Wire Manager
 - Horizontal Wire Manager
 - Wire Management Clips

To Order, Specify:

- 1) Product number, including:
 - ① Edge Options:**
 - K** Edgeband
 - U** Knife
 - ② Flip Top Unit Cutout Options:**
 - N** No cutout
 - A** 2 outlet cutout - centered back, add \$33.13 list
 - F** 4 outlet cutout - centered back, add \$33.13 list
 - J** 6 outlet cutout - centered back, add \$33.13 list
 - ③ Base Options (Flip/Non-Flip):**
 - H** Flip Top Table: Casters, add \$136.80 list
 - F** Flip Top Table: Glides, add \$214.80 list
 - C** Non-flip Top Table: Casters
 - G** Non-flip Top Table: Glides, add \$78.00 list
 - ④ Base/Stretcher Finish Options:**
 - A** Painted
 - B** Polished, add \$542.24 (must specify trim color for stretcher/arms)
- 2) Wood finish color.
- 3) Base/Stretcher trim color.
- 4) Caster/Glide Base Disc trim color.

Note: \$45.78 upcharge list for Metallic and accent trim colors.

Planes Training Table — Trapezoid — Wood

Flip Top or Non-Flip Top Table

Depth	Width	Number	① ② ③ ④				Wood Group A		Wood Group B	
			K	U	K	U				
30"(762mm)	60"(1524mm)	TATP-3060-W	S	C	4	\$1868.96	\$2108.56	\$1895.96	\$2144.56	

Non-Flip Top Table

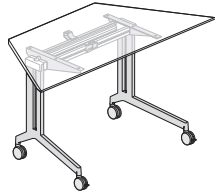
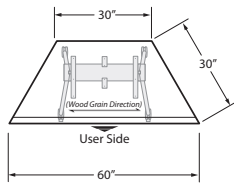

Flip Top Table

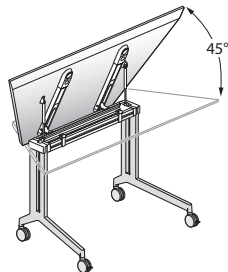
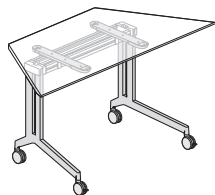

TATP-W

**Features**

- Includes 1-3/16"(30mm) thick top, two C-Leg bases, stretcher and hardware.
- Standard table height is 29" (737mm).
- Wood veneer top with 3mm edgeband on user edge and 1mm edgeband on remaining sides, or knife edge on user edge and 1mm edgeband on sides and back.
- Base Options:
 - Flip Top Table with casters (H) or with glides (F).
 - Non-flip Top Table with casters (C) or with glides (G).
- Flip Top Table:
 - Table top flips from horizontal to vertical position via pneumatic assist mechanism activated by two finger pulls.
 - Tables nest when flipped to vertical position. Refer to Specification Guide for details.
- Base and Stretcher Finish Options:
 - (A) Painted aluminum C-leg bases, glide stem and stretcher. Stretcher end caps and support arms or stretcher brackets match base trim color. (Specify trim color)
 - (B) Polished aluminum C-leg bases and glide stem. Stretcher and support arms or stretcher brackets are painted and require a trim color specification.
- Flip Top Unit Cutout Options include:
 - One cutout centered along back edge.
- Optional casters or glides are field interchangeable:
 - Casters (two locking/two non-locking) are available with:
 - Light platinum or fog hub with graphite tread, or
 - black hub with black tread.
- Optional glides (four) are available in light platinum, fog or black with 1/2"(13mm) height adjustment.
 - Glide stem is painted or polished to match base; glide base disc color must be specified.
- Depth and width shown in nominal dimensions.
- Ships unassembled.

Specification Tip

- The following Planes products are separately specified:
 - Ganging Mechanism - Required for use with powered tables.
 - Flip Top Unit electrical modules
 - Electrical Components
 - Grommet (field cut opening)
 - Modesty Panel
 - Vertical Wire Manager
 - Horizontal Wire Manager
 - Wire Management Clips

To Order, Specify:

- 1) Product number, including:

① Edge Options:

- K** Edgeband
- U** Knife

② Flip Top Unit Cutout Options:

- N** No cutout
- A** 2 outlet cutout - centered back, add **\$33.13** list
- F** 4 outlet cutout - centered back, add **\$33.13** list
- J** 6 outlet cutout - centered back, add **\$33.13** list

③ Base Options (Flip/Non-Flip):

- H** Flip Top Table: Casters, add **\$136.80** list
- F** Flip Top Table: Glides, add **\$214.80** list
- C** Non-flip Top Table: Casters
- G** Non-flip Top Table: Glides, add **\$78.00** list

④ Base/Stretcher Finish Options:

- A** Painted
- B** Polished, add **\$542.24** (must specify trim color for stretcher/arms)

- 2) Wood finish color.

- 3) Base/Stretcher trim color.

- 4) Caster/Glide Base Disc trim color.

Note: **\$45.78** upcharge list for Metallic and accent trim colors.

Planes Training Tables — Polygon — Wood

Flip Top or Non-Flip Top Table

Depth	Width	Number	① ② ③ ④				Wood Group A		Wood Group B	
			S	C	4		K	U	K	U
24"(610mm)	55"(1397mm)	TACV-2455-W	S	C	4		\$1526.68	\$1715.68	\$1550.78	\$1739.78
30"(762mm)	66"(1676mm)	TACV-3066-W	S	C	4		2014.69	2290.47	2056.87	2332.65

Non-Flip Top Table

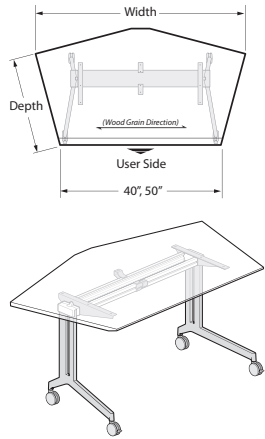

Flip Top Table

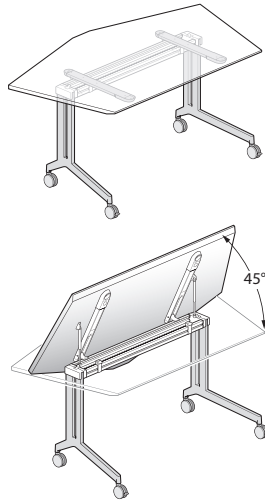

TACV-W



Features

- Includes 1-3/16"(30mm) thick top, two C-Leg bases, stretcher and hardware.
- Standard table height is 29"(737mm).
- Wood veneer top with 3mm edgeband on user edge and 1mm edgeband on remaining sides, or knife edge on user edge and 1mm edgeband on sides and back.
- Base Options:
 - Flip Top Table with casters (H) or with glides (F).
 - Non-flip Top Table with casters (C) or with glides (G).
- Flip Top Table:
 - Table top flips from horizontal to vertical position via pneumatic assist mechanism activated by two finger pulls.
 - Tables nest when flipped to vertical position. Refer to Specification Guide for details.
- Base and Stretcher Finish Options:
 - (A) Painted aluminum C-leg bases, glide stem and stretcher. Stretcher end caps and support arms or stretcher brackets match base trim color. (Specify trim color)
 - (B) Polished aluminum C-leg bases and glide stem. Stretcher and support arms or stretcher brackets are painted and require a trim color specification.
- Flip Top Unit Cutout Options include:
 - One cutout centered along back edge.
- Optional casters or glides are field interchangeable:
 - Casters (two locking/two non-locking) are available with: Light platinum or fog hub with graphite tread, or black hub with black tread.
- Optional glides (four) are available in light platinum, fog or black with 1/2"(13mm) height adjustment.
 - Glide stem is painted or polished to match base; glide base disc color must be specified.
- Depth and width shown in nominal dimensions.
- Ships unassembled.

Specification Tip

- The following Planes products are separately specified:
 - Ganging Mechanism - Required for use with powered tables.
 - Flip Top Unit electrical modules
 - Electrical Components
 - Grommet (field cut opening)
 - Modesty Panel
 - Vertical Wire Manager
 - Horizontal Wire Manager
 - Wire Management Clips

To Order, Specify:

1) Product number, including:

① Edge Options:

- K** Edgeband
- U** Knife

② Flip Top Unit Cutout Options:

- N** No cutout
- A** 2 outlet cutout - centered back, add \$33.13 list
- F** 4 outlet cutout - centered back, add \$33.13 list
- J** 6 outlet cutout - centered back, add \$33.13 list

③ Base Options (Flip/Non-Flip):

- H** Flip Top Table: Casters, add \$136.80 list
- F** Flip Top Table: Glides, add \$214.80 list
- C** Non-flip Top Table: Casters
- G** Non-flip Top Table: Glides, add \$78.00 list

④ Base/Stretcher Finish Options:

- A** Painted
- B** Polished, add \$542.24 (must specify trim color for stretcher/arms)

- 2) Wood finish color.
- 3) Base/Stretcher trim color.
- 4) Caster/Glide Base Disc trim color.

Note: \$45.78 upcharge list for Metallic and accent trim colors.

Planes Training Tables — Pie Connector — Wood

Depth	Number ^①	Wood Group A		Wood Group B	
		K	U	K	U
20" (508mm)	TAPC-2015-W SN	\$301.25	\$347.53	\$313.30	\$359.58
	TAPC-2030-W SN	325.36	371.64	337.41	383.69
	TAPC-2045-W SN	349.47	395.75	361.52	407.80
	TAPC-2090-W SN	397.69	443.97	409.74	456.02
24" (610mm)	TAPC-2415-W SN	\$373.56	\$419.84	\$385.61	\$431.89
	TAPC-2430-W SN	397.67	443.95	409.72	456.00
	TAPC-2445-W SN	421.78	468.06	433.83	480.11
	TAPC-2490-W SN	470.00	516.28	482.05	528.33
30" (762mm)	TAPC-3015-W SN	\$445.87	\$492.15	\$457.92	\$504.20
	TAPC-3030-W SN	469.98	516.26	482.03	528.31
	TAPC-3045-W SN	494.09	540.37	506.14	552.42
	TAPC-3090-W SN	542.31	588.59	554.36	600.64

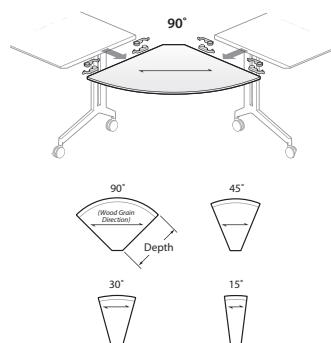

TAPC-W

Features

- Includes 1-3/16" (30mm) thick top and two sets of ganging mechanisms required for support.
- Wood veneer top with 3mm edgeband on user edge and 1mm edgeband on remaining sides, or knife edge on user edge and 1mm edgeband on sides and back.
- Depth shown in nominal dimensions.
- Ships unassembled.

Specification Tips

- Requires two same-depth Planes C-Leg Training Tables for support; separately specified.
- Additional Table Pass-Through Connector may be required based upon application.
- Wire Manager Clips are available if needed; separately specified.

To Order, Specify:

- 1) Product number, including:

① Edge Options:

- K Edgeband
- U Knife

- 2) Wood finish color.

Planes Training Tables — Modesty Panels

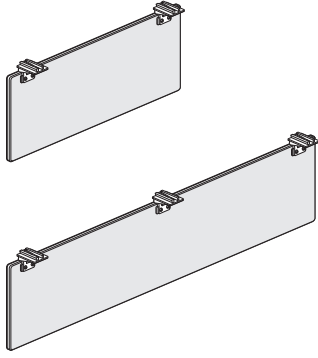

Features

- Includes modesty panel and attachment hardware.
- Modesty Panels are 11.59”(294mm) high (actual) and 0.56”(14mm) thick.
- Modesty Panels are mounted 1.4”(36mm) below the table top to allow for wire pass-through.
- Finish surface is non-tackable.
- Hinged bracket allows for table nesting without modesty panel removal.
- Modesty panel is removable; slides into table attachment brackets. No tools required.
- Screen and hardware are field installed.

Specification Tip

- Modesty Panels are available for use on Training Tables in shapes/sizes indicated. Refer to Specification Guide for application guidelines.

To Order, Specify:

- 1) Product number, including:

① Modesty Panel Options:

- F** Full width, add **\$48.19** list
- P** Powered Table

- 2) Surface Colors Options:

- Fabric:
 - Fabric Color
- Laminate:
 - Laminate Surface Color
 - Edgeband trim color
- Wood:
 - Wood Finish Color

* Note: Modesty Panel Options:

- (F) Full-width modesty panel will be width of the rectangular table and not for use with tables that are connected with 2-Circuit Modular Power or Quick Connect electrical components.
- (P) Must be ordered for tables with 2-Circuit Modular Power or Flip Top Units with Quick Connect Power base feed. Modesty Panels are inset 3”(76mm) from each end.

TA0M

Table Width	Option (P) Modesty Actual Width	Option (F) Modesty Actual Width	Number ①	Fabric Grade						
				A	B	C	D	E	F	G
Rectangle										
36”(914mm)	29.5”(749mm)	35.5”(902mm)	TA0M-1336-F	\$253.03	\$313.26	\$325.33	\$339.79	\$361.46	\$383.15	\$409.66
42”(1067mm)	35.5”(902mm)	41.5”(1054mm)	TA0M-1342-F	295.20	355.43	367.50	381.96	403.63	425.32	451.83
48”(1219mm)	41.5”(1064mm)	47.5”(1207mm)	TA0M-1348-F	337.37	397.60	409.67	424.13	445.80	467.49	494.00
54”(1372mm)	47.5”(1207mm)	53.5”(1359mm)	TA0M-1354-F	379.54	439.77	451.84	466.30	487.97	509.66	536.17
60”(1524mm)	53.5”(1369mm)	59.5”(1511mm)	TA0M-1360-F	421.71	481.94	494.01	508.47	530.14	551.83	578.34
66”(1676mm)	59.5”(1511mm)	65.5”(1664mm)	TA0M-1366-F	463.88	524.11	536.18	550.64	572.31	594.00	620.51
72”(1829mm)	65.5”(1664mm)	71.5”(1816mm)	TA0M-1372-F	506.05	566.28	578.35	592.81	614.48	636.17	662.68
78”(1981mm)	71.5”(1816mm)	77.5”(1969mm)	TA0M-1378-F	548.22	608.45	620.52	634.98	656.65	678.34	704.85
84”(2134mm)	77.5”(1969mm)	83.5”(2121mm)	TA0M-1384-F	590.39	650.62	662.69	677.15	698.82	720.51	747.02
90”(2286mm)	83.5”(2121mm)	89.5”(2273mm)	TA0M-1390-F	632.56	692.79	704.86	719.32	740.99	762.68	789.19
96”(2438mm)	89.5”(2273mm)	95.5”(2426mm)	TA0M-1396-F	674.73	734.96	747.03	761.49	783.16	804.85	831.36
Polygon										
55”(1397mm)	41.5”(1054mm)		TA0M-1348-FP	\$337.37	\$397.60	\$409.67	\$424.13	\$445.80	\$467.49	\$494.00
66”(1676mm)	47.5”(1207mm)	53.5”(1359mm)	TA0M-1354-F	379.54	439.77	451.84	466.30	487.97	509.66	536.17
Trapezoid										
60”(1524mm)	28”(711mm)		TA0M-1360-FP	\$421.71	\$481.94	\$494.01	\$508.47	\$530.14	\$551.83	\$578.34
Half Round										
60”(1524mm)	53.5”(1359mm)	59.5”(1511mm)	TA0M-1360-F	\$421.71	\$481.94	\$494.01	\$508.47	\$530.14	\$551.83	\$578.34

Planes Training Tables — Modesty Panels

Table Width	Option (P)	Option (F)	Number ①	Laminate	
	Modesty Actual Width	Modesty Actual Width		A	B
Rectangle					
36"(914mm)	29.5"(749mm)	35.5"(902mm)	TA0M-1336-L	\$135.56	\$142.36
42"(1067mm)	35.5"(902mm)	41.5"(1054mm)	TA0M-1342-L	156.72	165.22
48"(1219mm)	41.5"(1064mm)	47.5"(1207mm)	TA0M-1348-L	177.88	188.08
54"(1372mm)	47.5"(1207mm)	53.5"(1359mm)	TA0M-1354-L	199.04	210.94
60"(1524mm)	53.5"(1369mm)	59.5"(1511mm)	TA0M-1360-L	220.20	233.80
66"(1676mm)	59.5"(1511mm)	65.5"(1664mm)	TA0M-1366-L	241.36	256.66
72"(1829mm)	65.5"(1664mm)	71.5"(1816mm)	TA0M-1372-L	262.52	279.52
78"(1981mm)	71.5"(1816mm)	77.5"(1969mm)	TA0M-1378-L	283.68	302.38
84"(2134mm)	77.5"(1969mm)	83.5"(2121mm)	TA0M-1384-L	304.84	325.24
90"(2286mm)	83.5"(2121mm)	89.5"(2273mm)	TA0M-1390-L	326.00	348.10
96"(2438mm)	89.5"(2273mm)	95.5"(2426mm)	TA0M-1396-L	347.16	370.96
Polygon					
55"(1397mm)	41.5"(1054mm)		TA0M-1348-LP	\$177.88	\$188.08
66"(1676mm)	47.5"(1207mm)	53.5"(1359mm)	TA0M-1354-L	199.04	210.94
Trapezoid					
60"(1524mm)	28"(711mm)		TA0M-1360-LP	\$220.20	233.80
Half Round					
60"(1524mm)	53.5"(1359mm)	59.5"(1511mm)	TA0M-1396-L	\$220.20	233.80
Table Width	Option (P)	Option (F)	Number ①	Wood	
	Modesty Actual Width	Modesty Actual Width		A	B
Rectangle					
36"(914mm)	29.5"(749mm)	35.5"(902mm)	TA0M-1336-W	\$387.39	\$447.25
42"(1067mm)	35.5"(902mm)	41.5"(1054mm)	TA0M-1342-W	429.73	497.12
48"(1219mm)	41.5"(1064mm)	47.5"(1207mm)	TA0M-1348-W	472.07	546.99
54"(1372mm)	47.5"(1207mm)	53.5"(1359mm)	TA0M-1354-W	514.41	596.86
60"(1524mm)	53.5"(1369mm)	59.5"(1511mm)	TA0M-1360-W	556.75	646.73
66"(1676mm)	59.5"(1511mm)	65.5"(1664mm)	TA0M-1366-W	599.09	696.60
72"(1829mm)	65.5"(1664mm)	71.5"(1816mm)	TA0M-1372-W	641.43	746.47
78"(1981mm)	71.5"(1816mm)	77.5"(1969mm)	TA0M-1378-W	683.77	796.34
84"(2134mm)	77.5"(1969mm)	83.5"(2121mm)	TA0M-1384-W	726.11	846.21
90"(2286mm)	83.5"(2121mm)	89.5"(2273mm)	TA0M-1390-W	768.45	896.08
96"(2438mm)	89.5"(2273mm)	95.5"(2426mm)	TA0M-1396-W	810.79	945.95
Polygon					
55"(1397mm)	41.5"(1054mm)		TA0M-1348-WP	\$472.07	\$546.99
66"(1676mm)	47.5"(1207mm)	53.5"(1359mm)	TA0M-1354-W	514.41	596.86
Trapezoid					
60"(1524mm)	28"(711mm)		TA0M-1360-WP	\$556.75	\$646.73
Half Round					
60"(1524mm)	53.5"(1359mm)	59.5"(1511mm)	TA0M-1360-W	\$646.73	\$646.73

Planes Training Tables 2-Circuit — Power Feeds

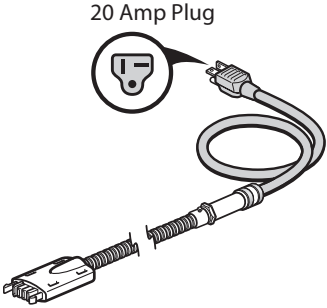
	Description	Number	Price
 <p>20 Amp Plug</p> <p>EAEB-2024-2C</p>	Single Circuit Corded Base Feed — for use with 2-Circuit, 20 Amp 20 Amp (USA Only)	EAEB-2024-2C	\$381.97
	Feature <ul style="list-style-type: none"> Includes one 24"(610mm) black cord with NEMA 5-20P plug plus a 48"(1219mm) flexible metal conduit (unpainted) with modular male connector standard in black. 	To Order, Specify: <ol style="list-style-type: none"> Product number. (No finish specification required.) 	
	Specification Tips <ul style="list-style-type: none"> For use on Planes C-Leg Training Tables only. Provides power to circuit one only. For use with 120 volt 60 hertz power source only. Electric application requires prior approval by authority having jurisdiction. Base Feed accesses common ground only. Requires a 20 Amp, 125 volt power receptacle (NEMA 5 20-R) for connection to building power (not included). Not for use in Canada due to electrical code restrictions. Corded Base Feed is PVC free. 		

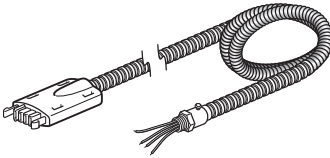

	Description	Length	Number	Price
 <p>EAEB</p>	Hardwire Modular Base Feed — 2-Circuit 20 Amp	48"(1219mm)	EAEB-2048-2H	\$114.47
		60"(1524mm)	EAEB-2060-2H	126.52
		72"(1829mm)	EAEB-2072-2H	138.57
		96"(2438mm)	EAEB-2096-2H	162.67
		120"(3048mm)	EAEB-20C0-2H	186.77
		180"(4572mm)	EAEB-20J0-2H	247.02
		240"(6096mm)	EAEB-20Q0-2H	307.27
		300"(7620mm)	EAEB-20W0-2H	367.52



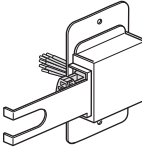

Feature <ul style="list-style-type: none"> Includes one flexible metal conduit (unpainted) base feed with four 12-gauge wires for up to two 20 Amp circuits of power and one modular male connector standard in black. 	To Order, Specify: <ol style="list-style-type: none"> Product number. (No finish specification required.) 	
Specification Tips <ul style="list-style-type: none"> For 2-circuit modular power components. Do not mix with other systems. For use for floor, column or wall hardwire connections. For use with 120 volt 60 hertz power source only. Electric application requires prior approval by authority having jurisdiction. Base Feed accesses common ground only. 		

 <p>EAWP-0004-21</p>	Wall Feed — 2-Circuit	EAWP-0004-21	\$110.85
Features <ul style="list-style-type: none"> Includes one 2-circuit wall feed with female connector and four 12-gauge wires for up to two 20 Amp circuits. Standard in black. 	To Order, Specify: <ol style="list-style-type: none"> Product number. (No finish specification required.) 		
Specification Tips <ul style="list-style-type: none"> For use with 2-Circuit components only. Do not mix with other power systems. For use with separately specified 2-circuit Pass-Through Connector. For use with 120 volt 60 hertz power source only. Electric application requires prior approval by authority having jurisdiction. For mounting on vertical surfaces only. 			

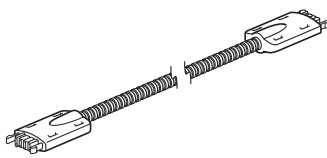

Planes Training Tables 2-Circuit — Modular Power Pass-Through

	Connector Width	Number	Price
Tables Pass-Through Connector — 2-Circuit  EAEJ  	10"(254mm)	EAEJ-0010-2	\$ 70.29
	18"(457mm)	EAEJ-0018-2	78.33
	24"(610mm)	EAEJ-0024-2	84.36
	30"(762mm)	EAEJ-0030-2	90.39
	36"(914mm)	EAEJ-0036-2	96.42
	42"(1067mm)	EAEJ-0042-2	102.45
	48"(1219mm)	EAEJ-0048-2	108.48
	54"(1372mm)	EAEJ-0054-2	114.51
	60"(1524mm)	EAEJ-0060-2	120.54
	66"(1676mm)	EAEJ-0066-2	126.57
	72"(1829mm)	EAEJ-0072-2	132.60
	78"(1981mm)	EAEJ-0078-2	138.63
	96"(2438mm)	EAEJ-0096-2	156.72

Features

- Includes one flexible metal conduit (unpainted) connector with modular male connectors standard in black.
- System is 4-wire with 2 circuits, 20 Amps each.
- Modular connectors are PVC-free.

To Order, Specify:

- 1) Product number.
(No finish specification required.)

Specification Tips

- For use with other 2-Circuit components only. Do not mix with other systems.
- Required for use with wall feed component to bring building power to Planes Training tables or for use to pass power between tables.
- **For use with 120 volt 60 hertz power source only.**
- **Electric application requires prior approval by authority having jurisdiction.**
- Pass-Through Connectors cannot be coupled together; separately specify Four-Port Splitter to connect Pass-Through Connectors.

Planes Training Tables 2-Circuit — Modular Power Kits

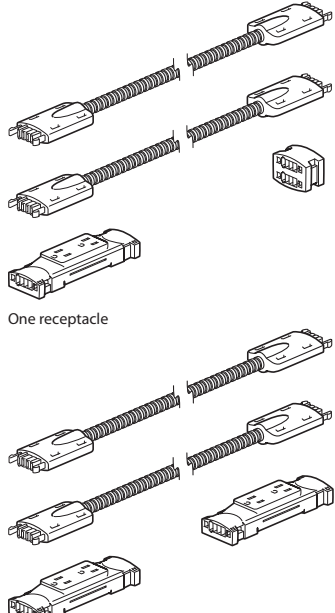
	Table Width	Number of Receptacles	Number	Price
 <p>One receptacle</p> <p>Two receptacles EAEM</p>	Rectangle			
	36"(914mm)	1	EAEM-3624-2JB	\$332.58
	42"(1067mm)	2	EAEM-4224-2JB	337.41
	48"(1219mm)	2	EAEM-4824-2JB	342.24
	54"(1372mm)	2	EAEM-5424-2JB	347.07
	60"(1524mm)	2	EAEM-6024-2JB	351.90
	66"(1676mm)	2	EAEM-6624-2JB	356.73
	72"(1829mm)	2	EAEM-7224-2JB	361.56
	78"(1981mm)	2	EAEM-7824-2JB	366.39
	84"(2134mm)	2	EAEM-8424-2JB	371.22
	90"(2286mm)	2	EAEM-9024-2JB	376.05
	96"(2438mm)	2	EAEM-9624-2JB	380.88
	Polygon			
	55"(1397mm)	2	EAEM-5524-2JB	\$351.90
	66"(1676mm)	2	EAEM-6624-2JBP	356.73
	Trapezoid			
	60"(1524mm)	2	EAEM-6024-2JB T	\$342.24
	Crescent			
	68"(1727mm)	2	EAEM-6824-2JB	\$361.56
Half Round				
60"(1524mm)	2	EAEM-6024-2JBH	\$351.90	

Features

- Kit with one receptacle includes two Pass-Through Connectors with flexible metal conduit (unpainted) with modular male connectors standard in black, one duplex receptacle (NEMA 5-15R configuration) and one Four-Port Splitter both standard in black.
- Kit with two receptacles includes two Pass-Through Connectors with flexible metal conduit (unpainted) with modular male connectors standard in black and two duplex receptacles (NEMA 5-15R configuration) standard in black.
- Receptacle(s) have two 15 Amp outlets (NEMA 5-15R configuration).
- Kit with one receptacle includes a circuit one receptacle.
- Kit with two receptacles includes a circuit one and a circuit two receptacle.
- Receptacles are circuit specific, accessing only common ground.
- System is 4-wire with 2 circuits; system rated for 20 Amps.
- Components are PVC-free.

To Order, Specify:







- 1) Product number.
(No finish specification required.)

Specification Tips

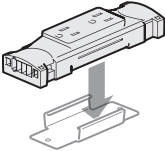

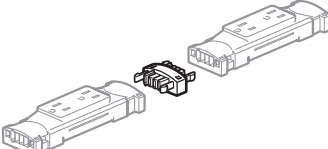

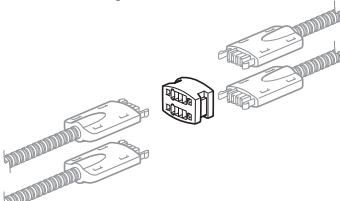
- **Designed for use with Planes C-Leg Training Tables only.**
- Included Pass-Through Connector is for use with in-line Planes Training Table applications; additional Pass-Through Connectors may be required for non-linear table applications.
- For use with separately specified corded Flip Top Unit.
- Separately specified table ganging mechanisms are required.
- **For use with 120 volt 60 hertz power source only.**
- **Electric application requires prior approval by authority having jurisdiction.**
- Up to 13 duplex receptacles allowed per circuit. (10 duplex receptacles in Canada)
- Up to 26 duplex receptacles per hardwired modular base feed. (20 duplex receptacles in Canada)

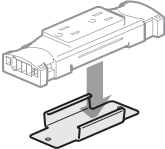

Planes Training Tables 2-Circuit — Modular Power Components

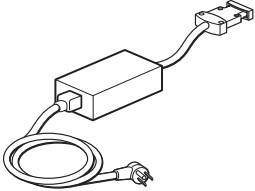
	Description	Circuit Access	Number	Price
Receptacles — 15 Amp 2-Circuit  EAER 	2-Circuit	1	EAER-0015-21G	\$72.31
		2	EAER-0015-22G	72.31
	Features <ul style="list-style-type: none"> Includes one modular 15 Amp duplex receptacle (NEMA 5-15R) with integral latching system. Receptacles are PVC-free and standard in black. 		To Order, Specify: <ol style="list-style-type: none"> Product number. (No finish specification required.) 	
	Specification Tips <ul style="list-style-type: none"> For use with 2-Circuit components only. Do not mix with other power systems. Receptacle(s) are included with Modular Power Kits. For use with 120 volt 60 hertz power source only. Electric application requires prior approval by authority having jurisdiction. Up to 13 duplex receptacles allowed per circuit. (10 duplex receptacles in Canada) Up to 26 duplex receptacles per hardwired modular base feed. (20 duplex receptacles in Canada) 			
Receptacle Block Connector  EAED-0000-22 	2-Circuit, 2-Port		EAED-0000-22	\$15.66
	Features <ul style="list-style-type: none"> Includes one receptacle block connector. Receptacle Block Connectors are PVC-free and standard in black. 		To Order, Specify: <ol style="list-style-type: none"> Product number. (No finish specification required.) 	
	Specification Tips <ul style="list-style-type: none"> For use with 2-Circuit components only. Do not mix with other power systems. Used for connecting two receptacles. For use with 120 volt 60 hertz power source only. Electric application requires prior approval by authority having jurisdiction. 			
Four-Port Splitter  EAED-0000-24 	2-Circuit, 4-Port		EAED-0000-24	\$28.36
	Features <ul style="list-style-type: none"> Includes one four-port splitter. Four-Port Splitters are PVC-free and standard in black. 		To Order, Specify: <ol style="list-style-type: none"> Product number. (No finish specification required.) 	
	Specification Tips <ul style="list-style-type: none"> For use with 2-Circuit components only. Do not mix with other power systems. Used for connecting pass-through connectors. Four-Port Splitters are included with Modular Power Kits. For use with 120 volt 60 hertz power source only. Electric application requires prior approval by authority having jurisdiction. 			
Mounting Bracket — Receptacle  TA01-0224			TA01-0224	\$6.03
	Features <ul style="list-style-type: none"> Includes one mounting bracket and mounting screws. Standard in black. Field installed. 		To Order, Specify: <ol style="list-style-type: none"> Product number. (No finish specification required.) 	
	Specification Tips <ul style="list-style-type: none"> For use to mount receptacles to table bottom in reconfiguration applications if needed. Mounting Brackets are included with all Planes C-Leg Training Tables. 			

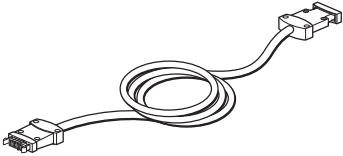
Planes Training Tables Quick Connect Power — Flip Top Unit Accessories

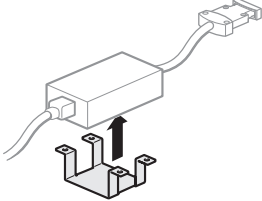
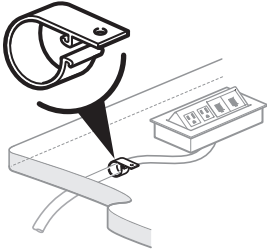
	Length	Number	Price
Starter Box  EAEB 		EAEB-0072-1	\$650.67
Features <ul style="list-style-type: none"> Includes 120”(3048mm) 15 Amp cord and starter box with female connector. Starter box with 12 Amp breaker (NEMA 5-15P configuration) features system indicator to limit number of connections. 			
To Order, Specify: <ol style="list-style-type: none"> Product number. (No finish specification required.) 			
Specification Tips <ul style="list-style-type: none"> Modular Connection attaches to a Flip Top Unit or Pass-Through Connector. Plug connects to building power receptacle. Planes Training Table applications may have up to eight modular connections; eight Flip Top Units and/or Pass-Through Connectors per Starter Box. UL 962 recognized — For use with Planes C-Leg Training Tables only. 			
Table Pass-Through Connector  EAEJ-1 	36”(914mm) 60”(1524mm)	EAEJ-0036-1 EAEJ-0060-1	\$ 96.42 120.54
Features <ul style="list-style-type: none"> Includes 36”(914mm) or 60”(1524mm) Pass-Through Connector with male and female connections. For use when additional Table Pass-Through Connector length is required between Flip Top Units. 			
To Order, Specify: <ol style="list-style-type: none"> Product number. (No finish specification required.) 			
Specification Tips <ul style="list-style-type: none"> Needed for rectangles greater than 60”(1524mm). May be needed for non-linear powered Planes C-Leg Training Table applications. Refer to Specification Guide for application guidelines. UL 962 recognized — For use with Planes C-Leg Training Tables only. 			
Starter Box Bracket  TA01-0227		TA01-0227	\$12.05
Features <ul style="list-style-type: none"> Includes one starter box bracket for mounting starter box under table (outside of stretcher). Standard in black. Field installed. 			
To Order, Specify: <ol style="list-style-type: none"> Product number. (No finish specification required.) 			
Specification Tip <ul style="list-style-type: none"> Required for use with non-flip Planes C-Leg Training Tables with starter box. 			
Wire Manager Clips  TA01-0225		TA01-0225	\$24.11
Features <ul style="list-style-type: none"> Includes ten wire manager clips and screws. Standard in black plastic. Field installed. 			
To Order, Specify: <ol style="list-style-type: none"> Product number. (No finish specification required.) 			
Specification Tip <ul style="list-style-type: none"> Specify for cord management as needed. 			

This page intentionally blank

Planes Training Tables Quick Connect Power

Flip Top Unit Accessories

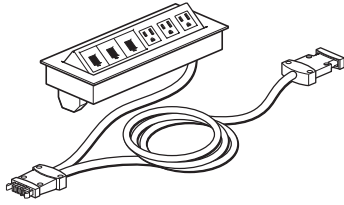

EAE1-A331



Features

- Includes bezel and flip top module with 2, 4 or 6 ports that can be configured with simplex outlets (NEMA 5-15R), USB charging simplex (with two USB outlets), data jack adapters or cable bay(s) that can accept up to 2 pull out data/AV cables, 60"(1524mm) modular connectors (one female, one male) and mounting hardware.
- Modular connection provides power distribution between tables.
- Non-sequential modular power connections allow easy table reconfiguration.
- Data jack adapters accommodate most varieties of field supplied data jacks or separately specified AV cables.
- Each cable bay can accept up to 2 pull out data/AV cables.
- USB charging port consists of 2 USB outlets. 1,000mA of charging power per USB outlet.
- Flip top unit is flush mounted with spring release cover.
- Flip top unit overall height is 2 3/4"(70mm) and will extend below the table top.
- Color option of black anodized housing with black receptacles or clear anodized housing with white receptacles.
- Ships assembled.

Specification Tips

- **UL 962 recognized — For use with Planes C-Leg Training Tables only.**
- Planes Training Table application may have up to eight modular connections; eight Flip Top Units and/or Pass-Through Connectors per Starter Box.
- **Separately specify Starter Box to provide power to Flip Top Units.**
- Separately specified table ganging mechanisms are required.
- **For use with 120 volt 60 hertz power source only.**
- Application may require approval of local authority having jurisdiction (AHJ); ensure compliance before placing orders and installation.
- Table Pass Through Connector needed for rectangles greater than 60"(1524mm) wide and some non-linear applications.

To Order, Specify:

- 1) Product number.
(No finish specification required.)

Note: Order flip top units to match flip top unit cutout option specified for each table (A/B, F/V or J/K).

Planes Training Tables Quick Connect Power

Flip Top Unit Accessories

Bezel Width	Bezel Depth	Housing Color	Port Color	Port	Configuration	Flip Top Unit Cutout Code Options	Number	Price
Single Circuit Base Feed Power								
5 1/4" (133mm)	4 3/8" (111mm)	Clear Anodized	Black	2	1 Power Receptacle, 1 Data Port	A, B	EAE1-A111-B1	\$ 783.23
					1 Power Receptacle, 1 USB Charging	A, B	EAE1-Q51B-1100	908.00
					2 Power Receptacles	A, B	EAE1-AB01-B1	783.23
8 5/16" (211mm)	4 3/8" (111mm)			4	1 Power Receptacle, 1 USB Charging, 1 Cable Bay	F, V	EAE1-Q51B-1102	\$ 956.19
					1 Power Receptacle, 1 USB Charging, 2 Data Ports	F, V	EAE1-Q51B-1120	956.19
					1 Power Receptacle, 1 Data Port, 1 Cable Bay	F, V	EAE1-Q51B-1012	889.35
					1 Power Receptacle, 3 Data Ports	F, V	EAE1-Q51B-1030	889.35
					2 Power Receptacles, 2 Data Ports	F, V	EAE1-A221-B1	831.42
					2 Power Receptacles, 1 USB Charging, 1 Data Port	F, V	EAE1-Q51B-2110	956.19
					2 Power Receptacles, 1 Cable Bay	F, V	EAE1-Q51B-2002	889.35
					3 Power Receptacles, 1 Data Port	F, V	EAE1-A311-B1	831.42
11 1/4" (286mm)	4 3/8" (111mm)			6	1 Power Receptacle, 1 USB Charging, 2 Data Ports, 1 Cable Bay	J, K	EAE1-Q51B-1122	\$ 992.34
					1 Power Receptacle, 1 USB Charging, 4 Data Ports	J, K	EAE1-Q51B-1140	992.34
					1 Power Receptacle, 2 USB Charging, 1 Data Port, 1 Cable Bay	J, K	EAE1-Q51B-1212	1059.18
					1 Power Receptacle, 2 USB Charging, 3 Data Ports	J, K	EAE1-Q51B-1230	1059.18
					1 Power Receptacle, 3 Data Ports, 1 Cable Bay	J, K	EAE1-Q51B-1032	925.50
					1 Power Receptacle, 5 Data Ports	J, K	EAE1-Q51B-1050	925.50
					2 Power Receptacles, 1 USB Charging, 1 Data Port, 1 Cable Bay	J, K	EAE1-Q51B-2112	992.34
					2 Power Receptacles, 1 USB Charging, 3 Data Ports	J, K	EAE1-Q51B-2130	992.34
					2 Power Receptacles, 2 Data Ports, 1 Cable Bay	J, K	EAE1-Q51B-2022	925.50
					3 Power Receptacles, 3 Data Ports	J, K	EAE1-A331-B1	867.57
5 1/4" (133mm)	4 3/8" (111mm)	Clear Anodized	White	2	1 Power Receptacle, 1 Data Port	A, B	EAE1-A111-W1	\$ 602.49
					1 Power Receptacle, 1 USB Charging	A, B	EAE1-Q51W-1100	727.26
					2 Power Receptacles	A, B	EAE1-AB01-W1	602.49
8 5/16" (211mm)	4 3/8" (111mm)			4	1 Power Receptacle, 1 USB Charging, 1 Cable Bay	F, V	EAE1-Q51W-1102	\$ 775.45
					1 Power Receptacle, 1 USB Charging, 2 Data Ports	F, V	EAE1-Q51W-1120	775.45
					1 Power Receptacle, 1 Data Port, 1 Cable Bay	F, V	EAE1-Q51W-1012	708.61
					1 Power Receptacle, 3 Data Ports	F, V	EAE1-Q51W-1030	708.61
					2 Power Receptacles, 2 Data Ports	F, V	EAE1-A221-W1	650.68
					2 Power Receptacles, 1 USB Charging, 1 Data Port	F, V	EAE1-Q51W-2110	775.45
					2 Power Receptacles, 1 Cable Bay	F, V	EAE1-Q51W-2002	708.61
					3 Power Receptacles, 1 Data Port	F, V	EAE1-A311-W1	650.68
11 1/4" (286mm)	4 3/8" (111mm)			6	1 Power Receptacle, 1 USB Charging, 2 Data Ports, 1 Cable Bay	J, K	EAE1-Q51W-1122	\$ 811.60
					1 Power Receptacle, 1 USB Charging, 4 Data Ports,	J, K	EAE1-Q51W-1140	811.60
					1 Power Receptacle, 2 USB Charging, 1 Data Port, 1 Cable Bay	J, K	EAE1-Q51W-1212	878.44
					1 Power Receptacle, 2 USB Charging, 3 Data Ports	J, K	EAE1-Q51W-1230	878.44
					1 Power Receptacle, 3 Data Ports, 1 Cable Bay	J, K	EAE1-Q51W-1032	744.76
					1 Power Receptacle, 5 Data Ports	J, K	EAE1-Q51W-1050	744.76
					2 Power Receptacles, 1 USB Charging, 1 Data Port, 1 Cable Bay	J, K	EAE1-Q51W-2112	811.60
					2 Power Receptacles, 1 USB Charging, 3 Data Ports	J, K	EAE1-Q51W-2130	811.60
					2 Power Receptacles, 2 Data Ports, 1 Cable Bay	J, K	EAE1-Q51W-2022	744.76
					3 Power Receptacles, 3 Data Ports	J, K	EAE1-A331-W1	686.83
3 Power Receptacles, 1 Data Port, 1 Cable Bay	J, K	EAE1-Q51W-3012	744.76					

Planes Training Tables — Accessories

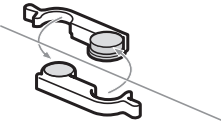
	Number	Price
Ganging Mechanism  TA01-0222 (one set)	TA01-0222	\$115.86

Features

- Includes four (two sets) ganging mechanisms and attachment hardware.
- Standard in black.
- Ganging Mechanism required for in-line powered Planes C-Leg and Y-Leg Training Tables.
- Field installed.

To Order, Specify:

- 1) Product number.
(No finish specification required.)

Specification Tip

- Planes C-Leg Training Tables are drilled for ganging mechanisms.

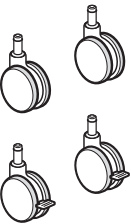
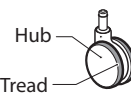
Casters   TA01-0216	TA01-0216	\$36.73
---	-----------	---------

Features



- Includes 4 casters: 2 locking, 2 non-locking.
 –Casters are available with:
 Light platinum or fog hub with graphite tread, or black hub with black tread.
- Field installed.

To Order, Specify:

- 1) Product number.
- 2) Trim color for hub.

Specification Tips

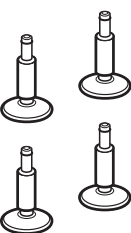
- Casters are for use with Planes C-Leg and Y-Leg Training Tables and carts.
- Casters and glides are field interchangeable.

	Description	Number	Price
Glides   TA01-0215	Painted Stem	TA01-0215	\$127.82
	Polished Stem	TA01-0223	\$127.82

Features

- Includes 4 adjustable glides.
- Glides have 1/2" (13mm) height adjustment.
- Glides stems are either painted (specify paint trim color) or polished aluminum.
- Glide base disc is available in light platinum, fog or black (specify trim color).
- Field installed.

To Order, Specify:

- 1) Product number.
- 2) Stem trim color (for painted Glide).
- 3) Base Disc trim color.

Specification Tips

- Glides are for use with Planes C-Leg and Y-Leg Training Tables and carts.
- Casters and glides are field interchangeable.

Planes Training Tables — Accessories

	Number	Price
Wire Manager Clips	TA01-0225	\$24.11

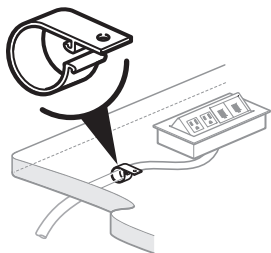

TA01-0225
Class TA1 – SIN 711-11;
Discount Group X

Features

- Includes ten wire manager clips and screws.
- Standard in black.
- Field installed.

To Order, Specify:

- 1) Product number.
(No finish specification required.)

Specification Tip

- Specify for cord management as needed.

	Length	Number	Price
Vertical Wire Manager	16"(406mm)	TA01-0228-F	\$44.58

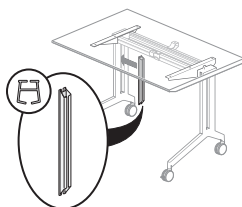

TA01-0228
Class TA1 – SIN 711-11;
Discount Group X

Features

- Includes one plastic wire manager.
- Standard in black.
- Field installed.

To Order, Specify:

- 1) Product number.
(No finish specification required.)

Specification Tip

- For use on Planes C-Leg Training Tables for wire management.
- Snaps into top portion of C-leg base.

	Top Thickness	Number	Price
Grommet	1 3/16"(30mm)	WQAG-0303-PS	\$43.26



WQAG-PS
Class PT – SIN 711-11;
Discount Group IX

Features

- Includes one 3"(76mm) diameter grommet with cover.
- Requires 2 3/4"(70mm) diameter field drilled hole.
- Field installed.

To Order, Specify:

- 1) Product number.
- 2) Trim color.

Planes Carts — Small Media

Cart – Small Media – Laminate or Wood

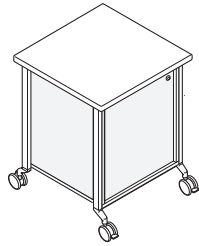

GAKF-1919

Height	Depth	Width	Number	① ②	Laminate A	B	Wood Group A	Group B
Laminate								
29"(737mm)	22"(559mm)	22 1/2"(572mm)	GAKF-1919-LJ SN	■ ■ 4	\$1263.45	\$1332.28		
Wood								
29"(737mm)	22"(559mm)	22 1/2"(572mm)	GAKF-1919-WKSN	■ ■ 4			\$1795.62	\$1827.09

Features

- Includes cart with one door, shelf and hardware.
- Laminate with 1mm edgeband or wood veneer with 1mm wood edgeband.
- Available in standard or green core option.
- Rails are aluminum and available in metallic trim colors only.
- Cart top has overhang with 22"(559mm) x 22 1/2"(572mm) usable top surface.
- Standard with one adjustable shelf – 1"(25mm) increments.
- Cart door has touch latch with locking option.
- Optional locks are available in black or chrome.
- For lock options refer to Lock Program Price List.
- Optional casters or glides are field interchangeable:
 - Casters (two locking/two non-locking) are available with:
 - Light platinum or fog hub with graphite tread, or black hub with black tread.
 - Optional glides (four) are available in light platinum, fog or black with 1/2"(13mm) height adjustment.
 - Glide stem is painted to match base; glide base disc color must be specified.
- Cart interior dimensions:
 - 17 3/8"(411mm) W x 21 5/8"(549mm) H x 16 7/8"(429mm) D
- Cart door opening: 16 1/2"(419mm) W x 21 5/8"(549mm) H
- Ships assembled.

To Order, Specify:

1) Product number, including:

① Door Locking Option:

- N Non-locking
- A Locking, add **\$66.36** list

② Base Option:

- C Caster
- G Glide

- 2) Laminate surface color or wood finish color.
- 3) Edge trim color for laminate.
- 4) Rail trim color. (Metallic and accent trim colors only.)
- 5) Caster/Glide base disc trim color:
 - Black – TR-F
 - Fog – TR-7
 - Light Platinum – TR-LPL
- 6) Lock plug trim color.
 - Black – LR-BL
 - Chrome – LR-BP

Planes Carts — Medium Media

Height	Depth	Width	Number	① ②	Laminate A	B	Wood Group A	Group B
Cart – Medium Media – Laminate or Wood								
Laminate								
36"(914mm)	19"(483mm)	19"(483mm)	GAKE-1919-LJ SN	6	\$1728.03	\$1796.86		
Wood								
36"(914mm)	19"(483mm)	19"(483mm)	GAKE-1919-WKSN	6			\$2193.84	\$2221.39

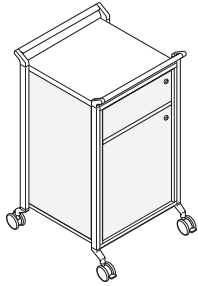

GAKE-1919

Features

- Includes cart with four doors and hardware.
- Laminate with 1mm edgeband or wood veneer with 1mm wood edgeband.
- Available in standard or green core.
- Standard with dual handles.
- Rails and handles are aluminum and available in metallic trim colors only.
- Cart standard with 2 3/4"(70mm) diameter bottom cutout for wire access to floor. Optional grommet separately specified for field retrofitting.
- Cart door configuration:
 - 6 3/8"(162mm) high upper touch latch flap door in front and back that folds down flat to allow air flow and is standard with locking option
 - 21 3/4"(552mm) lower touch latch door in front and back with locking option with adjustable shelf in 1"(25mm) increments
- 4"(101mm) deep full-height enclosure in front for power and cable management.
- Optional locks are available in black or chrome.
- For lock options refer to Lock Program Price List.
- Optional casters or glides are field interchangeable:
 - Casters (two locking/two non-locking) are available with: Light platinum or fog hub with graphite tread, or black hub with black tread.
- Optional glides (four) are available in light platinum, fog or black with 1/2"(13mm) height adjustment.
 - Glide stem is painted to match base; glide base disc color must be specified.
- Glides are light platinum with 1/2"(13mm) height adjustment.
- Ships assembled.

To Order, Specify:

- 1) Product number, including:

① Door Locking Option:

- N** Non-locking
- A** Locking, add **\$66.36** list

② Base Option:

- C** Caster
- G** Glide

- 2) Laminate surface color or wood finish color.
- 3) Edge trim color for laminate.
- 4) Rail trim color. (Metallic and accent trim colors only.)
- 5) Caster/Glide base disc trim color:
 - Black – TR-F
 - Fog – TR-7
 - Light Platinum – TR-LPL
- 6) Lock plug trim color.
 - Black – LR-BL
 - Chrome – LR-BP

Specification Tip

The following Planes products are separately specified:

- Grommet

Planes Carts – Catering

	Height	Depth	Width	Number	①	Laminate A	B	
Cart – Catering – Laminate	36”(914mm)	19”(483mm)	35 1/4”(895mm)	GAKG-1935-LJ	SNN	6	\$1528.92	\$1597.75



GAKG-1935

Features

- Includes cart, shelf and shelf hardware.
- Laminate with 1mm edgeband.
- Available in standard or green core option.
- Standard with dual handles.
- Rails and handles are aluminum and available in metallic trim colors only.
- Standard with center adjustable shelf; 3 1/2”(89mm) increments.
- Each cart end has upper and lower open stationary shelves with shelf rails to accommodate beverage containers.
- Optional casters or glides are field interchangeable:
 - Casters (two locking/two non-locking) are available with:
 - Light platinum or fog hub with graphite tread, or
 - black hub with black tread.
 - Optional glides (four) are available in light platinum, fog or black with 1/2”(13mm) height adjustment.
 - Glide stem is painted to match base; glide base disc color must be specified.
- Ships assembled.

To Order, Specify:

- 1) Product number, including:

① Base Option:

- C Caster
- G Glide

- 2) Laminate surface color.
- 3) Edge trim color for laminate.
- 4) Rail and handles trim color. (Metallic and accent trim colors only.)
- 5) Caster/Glide base disc trim color:
 - Black – TR-F
 - Fog – TR-7
 - Light Platinum – TR-LPL

Planes Cart – Podium

Height	Depth	Width	Number	① ②	Laminate A	B	Wood Group A	Group B
Cart – Podium – Laminate or Wood								
Laminate								
46"(1168mm)	22 1/4"(565mm)	22 1/2"(572mm)	GAKD-1919-LJ	SN	■	■ 9	\$2127.47	\$2196.30
Wood								
46"(1168mm)	22 1/4"(565mm)	22 1/2"(572mm)	GAKD-1919-WKSN	■	■ 9		\$3594.96	\$3681.74

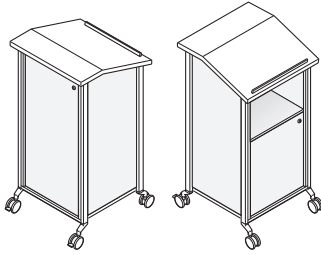

GAKD-1919

Features

- Includes podium, shelf and hardware.
- Laminate with 1mm edgeband or wood veneer with 1mm wood edge.
- Available in standard or green core.
- Podium sloping top is 22 1/2"(572mm) wide x 16 3/8"(416mm) deep with paper ledge.
- Rails are aluminum and available in metallic trim colors only.
- Optional casters or glides are field interchangeable:
 - Casters (two locking/two non-locking) are available with:
 - Light platinum or fog hub with graphite tread, or
 - black hub with black tread.
- Optional glides (four) are available in light platinum, fog or black with 1/2"(13mm) height adjustment.
 - Glide stem is painted to match base; glide base disc color must be specified.
- Podium doors are touch latch and available as all locking or all non-locking.
- Optional locks are available in black or chrome
- For lock options refer to Lock Program Price List.
- Podium user side has open shelf, lower storage with lockable touch latch door and one adjustable shelf.
- Podium back has touch latch, lockable full height door with full-height enclosure for power and cable management.
- Podium bottom has 2 3/4"(70mm) cutout for wire access to floor.
 - Optional grommet can be ordered separately for field installation.
- Ships assembled.

Specification Tip

The following Planes products are separately specified:
–Grommet

To Order, Specify:

1) Product number, including:

① Door Locking Option:

- N Non-locking, all
- A Locking, add **\$66.36** list

② Base Option:

- C Caster
- G Glide

2) Laminate surface color or wood finish color.

3) Edge trim color for laminate.

4) Rail trim color.
(Metallic and accent trim colors only.)

5) Caster/Glide base disc trim color:
Black – TR-F
Fog – TR-7
Light Platinum – TR-LPL

6) Lock plug trim color.
Black – LR-BL
Chrome – LR-BP

Planes Credenza Bases – 19" High

Overall Height*	Depth	Width	Number	①	Laminate		Wood		
					A	B	Group A	Group B	
Credenza Base – 19"(483mm) High – Laminate or Wood									
Laminate									
19"(483mm)	20"(508mm)	36"(914mm)	GAC1-2036-LNSN	G2	\$1128.26	\$1197.09			
		48"(1219mm)	GAC1-2048-LNSN	G2	1496.96	1602.67			
		54"(1372mm)	GAC1-2054-LNSN	G2	1681.31	1805.46			
		72"(1829mm)	GAC1-2072-LNSN	G2	2234.36	2413.83			
		96"(2438mm)	GAC1-2096-LNSN	G2	2971.76	3224.99			
		108"(2743mm)	GAC1-20A8-LNSN	G2	3340.46	3630.57			
Wood									
19"(483mm)	20"(508mm)	36"(914mm)	GAC1-2036-WNSN	G2			\$1908.71	\$1957.05	
		48"(1219mm)	GAC1-2048-WNSN	G2			2535.51	2623.21	
		54"(1372mm)	GAC1-2054-WNSN	G2			2848.91	2956.29	
		72"(1829mm)	GAC1-2072-WNSN	G2			3789.11	3955.53	
		96"(2438mm)	GAC1-2096-WNSN	G2			5042.71	5287.85	
		108"(2743mm)	GAC1-20A8-WNSN	G2			5669.51	5954.01	

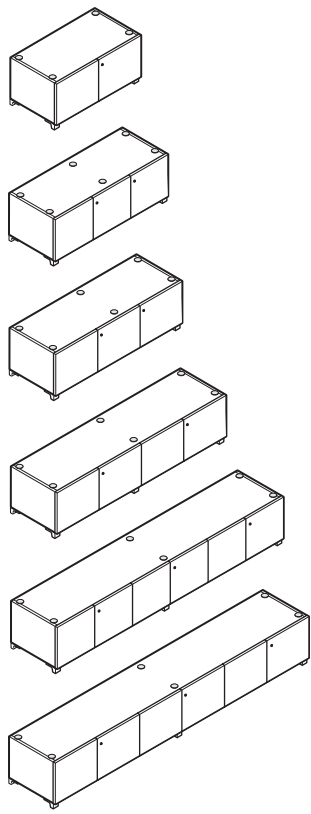

GAC1

Features

- Includes 19"(483mm) high base cabinet with one or more shelves, doors, legs and hardware.
- **Credenza top is ordered separately.**
- Laminate with 1mm edgeband or wood veneer with wood 1mm edgeband.
- Wood door fronts are matched veneer.
- 1/8"(3mm) reveal between credenza top and base
- Credenza base available in standard core.
- Cabinet doors have touch latches.
- Optional locks are available in Black or Chrome.
- For lock options refer to Lock Program Price List.
- Leg is 2 1/4"(57mm) high painted aluminum.
- Available with black glides only; 1 1/2"(38mm) height adjustment.
- Includes one adjustable shelf per cabinet with 1 1/4"(32mm) adjustment increments.
 - 36"(914mm) wide has two doors and four legs
 - 48"(1219mm) wide has three doors and four legs
 - 54"(1372mm) wide has three doors and four legs
 - 72"(1829mm) wide has four doors and six legs
 - 96"(2438mm) wide has six doors and six legs
 - 108"(2743mm) wide has six doors and six legs
- Ships unassembled.

Specification Tips

- **Must order a 1 3/16"(30mm) thick credenza top separately.**
- Grommets are ordered separately and requires field cutting and installation.

* Overall height includes credenza base, legs, reveal and separately specified credenza top.

To Order, Specify:

1) Product number, including:

① Locking Option:

- N Non-locking
- A All locking, add \$66.28 list

- 2) Laminate surface color or wood finish color.
- 3) Edge trim color for laminate.
- 4) Leg trim color.
- 5) Lock plug trim color.
 - Black – LR-BL
 - Chrome – LR-BP

Note: \$45.78 upcharge (list) for Metallic trim colors.

Planes Credenza Base with Slider Unit – 29" High

Overall Height*	Depth	Width	Number	①	Glass A	C	D	F	Translucent
Credenza Base – 29" (737mm) High with Slider Unit – Laminate or Wood									
Laminate – Grade A									
29"(737mm)	20"(508mm)	36"(914mm)	GAC2-2036-LGSN	G4	\$1741.56	\$ 2144.68	\$ 2204.92	\$ 2326.71	\$1943.13
		48"(1219mm)	GAC2-2048-LGSN	G4	2318.72	2856.28	2936.94	3098.93	2586.67
		54"(1372mm)	GAC2-2054-LGSN	G4	2607.30	3212.08	3302.95	3485.04	2908.44
		72"(1829mm)	GAC2-2072-LGSN	G4	3473.04	4279.48	4400.98	4643.37	3873.75
		96"(2438mm)	GAC2-2096-LGSN	G4	4627.36	5702.68	5865.02	6187.81	5160.83
		108"(2743mm)	GAC2-20A8-LGSN	G4	5204.52	6414.28	6597.04	6960.03	5804.37
Laminate – Grade B									
29"(737mm)	20"(508mm)	36"(914mm)	GAC2-2036-LGSN	G4	\$1881.67	\$ 2284.79	\$ 2345.03	\$ 2466.82	\$2083.24
		48"(1219mm)	GAC2-2048-LGSN	G4	2505.07	3042.63	3123.29	3285.28	2773.02
		54"(1372mm)	GAC2-2054-LGSN	G4	2816.77	3421.55	3512.42	3694.51	3117.91
		72"(1829mm)	GAC2-2072-LGSN	G4	3751.87	4558.31	4679.81	4922.20	4152.58
		96"(2438mm)	GAC2-2096-LGSN	G4	4998.67	6073.99	6236.33	6559.12	5532.14
		108"(2743mm)	GAC2-20A8-LGSN	G4	5622.07	6831.83	7014.59	7377.58	6221.92
Wood Group A									
29"(737mm)	20"(508mm)	36"(914mm)	GAC2-2036-WGSN	G4	\$3088.62	\$ 3491.74	\$ 3551.98	\$ 3673.77	\$3290.19
		48"(1219mm)	GAC2-2048-WGSN	G4	4032.04	4569.60	4650.26	4812.25	4299.99
		54"(1372mm)	GAC2-2054-WGSN	G4	4503.75	5108.53	5199.40	5381.49	4804.89
		72"(1829mm)	GAC2-2072-WGSN	G4	5918.88	6725.32	6846.82	7089.21	6319.59
		96"(2438mm)	GAC2-2096-WGSN	G4	7805.72	8881.04	9043.38	9366.17	8339.19
		108"(2743mm)	GAC2-20A8-WGSN	G4	8749.14	9958.90	10141.66	10504.65	9348.99
Wood Group B									
29"(737mm)	20"(508mm)	36"(914mm)	GAC2-2036-WGSN	G4	\$3169.73	\$ 3572.85	\$ 3633.09	\$ 3754.88	\$3371.30
		48"(1219mm)	GAC2-2048-WGSN	G4	4135.03	4672.59	4753.25	4915.24	4402.98
		54"(1372mm)	GAC2-2054-WGSN	G4	4617.68	5222.46	5313.33	5495.42	4918.82
		72"(1829mm)	GAC2-2072-WGSN	G4	6065.63	6872.07	6993.57	7235.96	6466.34
		96"(2438mm)	GAC2-2096-WGSN	G4	7996.23	9071.55	9233.89	9556.68	8529.70
		108"(2743mm)	GAC2-20A8-WGSN	G4	8961.53	10171.29	10354.05	10717.04	9561.38

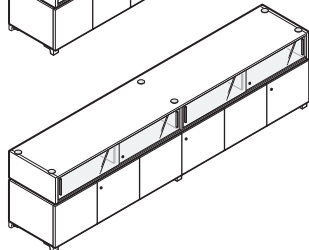
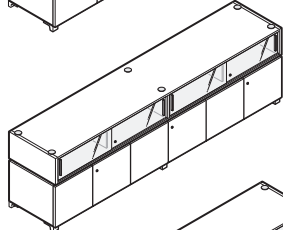
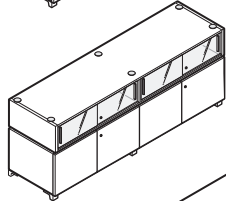
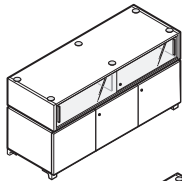
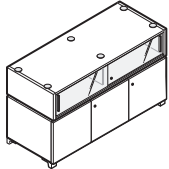
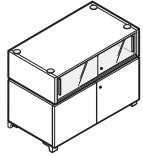

GAC2

Features

- Includes 19"(483mm) high base cabinet with one shelf, doors, legs and 10"(254mm) high upper slider unit with glass or translucent slider doors, pulls and hardware.
- Credenza top is ordered separately.**
- Laminate with 1mm edgeband or wood veneer with 1mm wood edgeband.
- Wood door fronts are matched veneer.
- 1/8"(3mm) reveal between base and slider unit and between slider unit and credenza top.
- Available in standard core.
- Cabinet doors have touch latches.
- Slider unit doors are glass or translucent with painted aluminum bar pulls.
- Optional locks are available in black or chrome.
- For lock options refer to Lock Program Price List.
- Leg is 2 1/4"(57mm) high painted metal.
- Available with black glides only; 1 1/2"(38mm) height adjustment.
- Cabinet includes one adjustable shelf per cabinet with 1 1/4"(32mm) adjustment increments.
 - 36"(914mm) wide has two doors and four legs
 - 48"(1219mm) wide has three doors and four legs
 - 54"(1372mm) wide has three doors and four legs
 - 72"(1829mm) wide has four doors and six legs
 - 96"(2438mm) wide has six doors and six legs
 - 108"(2743mm) wide has six doors and six legs
- Ships unassembled.

Specification Tip

- Must order a 1 3/16"(30mm) thick credenza top separately.**

* Overall height includes credenza base, legs, reveal, slider unit and separately specified credenza top.

To Order, Specify:

- Product number, including:

① Locking Option:

- N** Non-locking
- A** All locking, add \$132.75 list
- L** Slider unit locking only, add \$66.28 list

- Laminate surface color or wood finish color.
- Edge trim color for laminate.
- Leg and slider pull trim color.
- Slider unit glass/translucent door.
- Lock plug trim color.
 - Black – LR-BL
 - Chrome – LR-BP

Note: \$45.78 upcharge (list) for Metallic trim colors.

Planes Credenza Base with Slider Unit — 35" High

Overall Height*	Depth	Width	Number	①	Glass A	C	D	F	Translucent
Credenza Base – 35"(889mm) High with Slider Unit – Laminate or Wood									
Laminate – Grade A									
35"(889mm)	20"(508mm)	36"(914mm)	GAC2-2036-LGSN	G6	\$2090.62	\$ 2493.74	\$ 2553.98	\$ 2675.77	\$ 2292.19
		48"(1219mm)	GAC2-2048-LGSN	G6	2780.88	3318.44	3399.10	3561.09	3048.83
		54"(1372mm)	GAC2-2054-LGSN	G6	3126.01	3730.79	3821.66	4003.75	3427.15
		72"(1829mm)	GAC2-2072-LGSN	G6	4161.40	4967.84	5089.34	5331.73	4562.11
		96"(2438mm)	GAC2-2096-LGSN	G6	5541.92	6617.24	6779.58	7102.37	6075.39
		108"(2743mm)	GAC2-20A8-LGSN	G6	6232.18	7441.94	7624.70	7987.69	6832.03
Laminate – Grade B									
35"(889mm)	20"(508mm)	36"(914mm)	GAC2-2036-LGSN	G6	\$2230.73	\$ 2633.85	\$ 2694.09	\$ 2815.88	\$ 2432.30
		48"(1219mm)	GAC2-2048-LGSN	G6	2967.23	3504.79	3585.45	3747.44	3235.18
		54"(1372mm)	GAC2-2054-LGSN	G6	3335.48	3940.26	4031.13	4213.22	3636.62
		72"(1829mm)	GAC2-2072-LGSN	G6	4440.23	5246.67	5368.17	5610.56	4840.94
		96"(2438mm)	GAC2-2096-LGSN	G6	5913.23	6988.55	7150.89	7473.68	6446.70
		108"(2743mm)	GAC2-20A8-LGSN	G6	6649.73	7859.49	8042.25	8405.24	7249.58
Wood Group A									
35"(889mm)	20"(508mm)	36"(914mm)	GAC2-2036-WGSN	G6	\$3437.68	\$ 3840.80	\$ 3901.04	\$ 4022.83	\$ 3639.25
		48"(1219mm)	GAC2-2048-WGSN	G6	4494.20	5031.76	5112.42	5274.41	4762.15
		54"(1372mm)	GAC2-2054-WGSN	G6	5022.46	5627.24	5718.11	5900.20	5323.60
		72"(1829mm)	GAC2-2072-WGSN	G6	6607.24	7413.68	7535.18	7777.57	7007.95
		96"(2438mm)	GAC2-2096-WGSN	G6	8720.28	9795.60	9957.94	10280.73	9253.75
		108"(2743mm)	GAC2-20A8-WGSN	G6	9776.80	10986.56	11169.32	11532.31	10376.65
Wood Group B									
35"(889mm)	20"(508mm)	36"(914mm)	GAC2-2036-WGSN	G6	\$3518.79	\$ 3921.91	\$ 3982.15	\$ 4103.94	\$ 3720.36
		48"(1219mm)	GAC2-2048-WGSN	G6	4597.19	5134.75	5215.41	5377.40	4865.14
		54"(1372mm)	GAC2-2054-WGSN	G6	5136.39	5741.17	5832.04	6014.13	5437.53
		72"(1829mm)	GAC2-2072-WGSN	G6	6753.99	7560.43	7681.93	7924.32	7154.70
		96"(2438mm)	GAC2-2096-WGSN	G6	8910.79	9986.11	10148.45	10471.24	9444.26
		108"(2743mm)	GAC2-20A8-WGSN	G6	9989.19	11198.95	11381.71	11744.70	10589.04

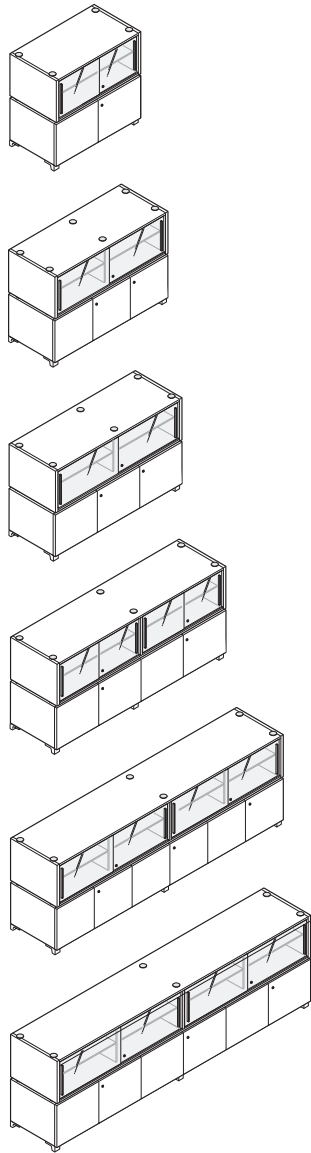

GAC2

Features

- Includes 19"(483mm) high base cabinet with one shelf, doors, legs and 16"(406mm) high upper slider unit with one shelf, glass or acrylic slider doors, door tracks, pulls and hardware.
- **Credenza top is ordered separately.**
- Laminate with 1mm edgeband or wood veneer with 1mm wood edgeband.
- Wood door fronts are matched veneer.
- 1/8"(3mm) reveal between base and slider unit and between slider unit and credenza top.
- Credenza available in standard core.
- Cabinet doors have touch latches.
- Slider unit doors are glass or translucent with painted aluminum bar pulls.
- Optional locks are available in black or chrome.
- For lock options refer to Lock Program Price List.
- Leg is 2 1/4"(57mm) high painted metal.
- Available with Black glides only; 1 1/2"(38mm) height adjustment.
- Slider unit includes one adjustable shelf per unit with 1 1/4"(32mm) adjustment increments.
- Cabinet includes one adjustable shelf per cabinet with 1 1/4"(32mm) adjustment increments.
 - 36"(914mm) wide has two doors and four legs
 - 48"(1219mm) wide has three doors and four legs
 - 54"(1372mm) wide has three doors and four legs
 - 72"(1829mm) wide has four doors and six legs
 - 96"(2438mm) wide has six doors and six legs
 - 108"(2743mm) wide has six doors and six legs
- Ships unassembled.

Specification Tip

- **Must order a 1 3/16"(30mm) thick credenza top separately.**

* Overall height includes credenza base legs, reveal, slider unit and credenza top.

To Order, Specify:

- 1) Product number, including:
 - ① **Locking Option:**
 - N** Non-locking
 - A** All locking, add \$132.75 list
 - L** Slider unit locking only, add \$66.28 list
- 2) Laminate surface color or wood finish color.
- 3) Edge trim color for laminate.
- 4) Leg and slider door pull trim color.
- 5) Slider unit glass/translucent door.
- 6) Lock plug trim color.
 - Black – LR-BL
 - Chrome – LR-BP

Note: \$45.78 upcharge (list) for Metallic trim colors.

Planes Credenza Base – 29" High

Overall Height*	Depth	Width	Number	①	Laminate		Wood		
					A	B	Group A	Group B	
Credenza Base – 29" (737mm) High – Laminate or Wood									
Laminate									
29" (737mm)	20" (508mm)	36" (914mm)	GAC1-2036-LNSN	G4	\$1504.46	\$1573.29			
		48" (1219mm)	GAC1-2048-LNSN	G4	2009.01	2114.72			
		54" (1372mm)	GAC1-2054-LNSN	G4	2256.06	2380.21			
		72" (1829mm)	GAC1-2072-LNSN	G4	2986.76	3166.23			
		96" (2438mm)	GAC1-2096-LNSN	G4	3985.41	4238.64			
		108" (2743mm)	GAC1-20A8-LNSN	G4	4479.51	4769.62			
Wood									
29" (737mm)	20" (508mm)	36" (914mm)	GAC1-2036-WNSN	G4			\$2284.91	\$2333.25	
		48" (1219mm)	GAC1-2048-WNSN	G4			3047.56	3135.26	
		54" (1372mm)	GAC1-2054-WNSN	G4			3423.66	3531.04	
		72" (1829mm)	GAC1-2072-WNSN	G4			4541.51	4707.93	
		96" (2438mm)	GAC1-2096-WNSN	G4			6056.36	6301.50	
		108" (2743mm)	GAC1-20A8-WNSN	G4			6808.56	7093.06	

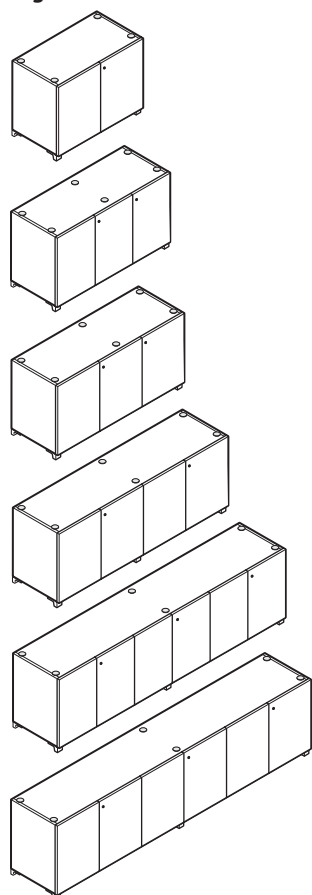

GAC1

Features

- Includes 29" (737mm) high base cabinet with two shelves, doors, legs and hardware.
- **Credenza top is ordered separately.**
- Laminate with 1mm edgeband or wood veneer with 1mm wood edgeband.
- Wood door fronts are matched veneer.
- 1/8" (3mm) reveal between base unit and credenza top.
- Credenza available in standard core.
- Cabinet doors have touch latches.
- Optional locks are available in black or chrome.
- For lock options refer to Lock Program Price List.
- Leg is 2 1/4" (57mm) high painted metal.
- Available with black glides only; 1 1/2" (38mm) height adjustment.
- Includes one adjustable shelf per cabinet with 1/4" (6mm) adjustment increments.
 - 36" (914mm) wide has two doors and four legs
 - 48" (1219mm) wide has three doors and four legs
 - 54" (1372mm) wide has three doors and four legs
 - 72" (1829mm) wide has four doors and six legs
 - 96" (2438mm) wide has six doors and six legs
 - 108" (2743mm) wide has six doors and six legs
- Ships unassembled.

Specification Tips

- **Must order a 1 3/16" (30mm) thick credenza top separately.**
- Grommets are ordered separately and requires field cutting and installation.

* Overall height includes credenza base legs, reveal, slider unit and separately specified credenza top.

To Order, Specify:

- 1) Product number, including:

① Locking Option:

- N Non-locking
- A All locking, add \$66.28 list

- 2) Laminate surface color or wood finish color.
- 3) Edge trim color for laminate.
- 4) Leg trim color.
- 5) Lock plug trim color.
 - Black – LR-BL
 - Chrome – LR-BP

Note: \$45.78 upcharge (list) for Metallic trim colors.

Planes Credenza Base with Slider Unit — 39" High

Overall Height*	Depth	Width	Number	①	Glass A	C	D	F	Translucent
Credenza Base – 39”(991mm) High with Slider Unit – Laminate or Wood									
Laminate – Grade A									
39”(991mm)	20”(508mm)	36”(914mm)	GAC2-2036-LGSN	G7	\$ 2107.82	\$ 2510.94	\$ 2571.18	\$ 2692.97	\$ 2309.39
		48”(1219mm)	GAC2-2048-LGSN	G7	2807.14	3344.70	3425.36	3587.35	3075.09
		54”(1372mm)	GAC2-2054-LGSN	G7	3156.80	3761.58	3852.45	4034.54	3457.94
		72”(1829mm)	GAC2-2072-LGSN	G7	4205.78	5012.22	5133.72	5376.11	4606.49
		96”(2438mm)	GAC2-2096-LGSN	G7	5604.42	6679.74	6842.08	7164.87	6137.89
		108”(2743mm)	GAC2-20A8-LGSN	G7	6303.74	7513.50	7696.26	8059.25	6903.59
Laminate – Grade B									
39”(991mm)	20”(508mm)	36”(914mm)	GAC2-2036-LGSN	G7	\$ 2247.93	\$ 2651.05	\$ 2711.29	\$ 2833.08	\$ 2449.50
		48”(1219mm)	GAC2-2048-LGSN	G7	2993.49	3531.05	3611.71	3773.70	3261.44
		54”(1372mm)	GAC2-2054-LGSN	G7	3366.27	3971.05	4061.92	4244.01	3667.41
		72”(1829mm)	GAC2-2072-LGSN	G7	4484.61	5291.05	5412.55	5654.94	4885.32
		96”(2438mm)	GAC2-2096-LGSN	G7	5975.73	7051.05	7213.39	7536.18	6509.20
		108”(2743mm)	GAC2-20A8-LGSN	G7	6721.29	7931.05	8113.81	8476.80	7321.14
Wood Group A									
39”(991mm)	20”(508mm)	36”(914mm)	GAC2-2036-WGSN	G7	\$ 3454.88	\$ 3858.00	\$ 3918.24	\$ 4040.03	\$ 3656.45
		48”(1219mm)	GAC2-2048-WGSN	G7	4520.46	5058.02	5138.68	5300.67	4788.41
		54”(1372mm)	GAC2-2054-WGSN	G7	5053.25	5658.03	5748.90	5930.99	5354.39
		72”(1829mm)	GAC2-2072-WGSN	G7	6651.62	7458.06	7579.56	7821.95	7052.33
		96”(2438mm)	GAC2-2096-WGSN	G7	8782.78	9858.10	10020.44	10343.23	9316.25
		108”(2743mm)	GAC2-20A8-WGSN	G7	9848.36	11058.12	11240.88	11603.87	10448.21
Wood Group B									
39”(991mm)	20”(508mm)	36”(914mm)	GAC2-2036-WGSN	G7	\$ 3535.99	\$ 3939.11	\$ 3999.35	\$ 4121.14	\$ 3737.56
		48”(1219mm)	GAC2-2048-WGSN	G7	4623.45	5161.01	5241.67	5403.66	4891.40
		54”(1372mm)	GAC2-2054-WGSN	G7	5167.18	5771.96	5862.83	6044.92	5468.32
		72”(1829mm)	GAC2-2072-WGSN	G7	6798.37	7604.81	7726.31	7968.70	7199.08
		96”(2438mm)	GAC2-2096-WGSN	G7	8973.29	10048.61	10210.95	10533.74	9506.76
		108”(2743mm)	GAC2-20A8-WGSN	G7	10060.75	11270.51	11453.27	11816.26	10660.60

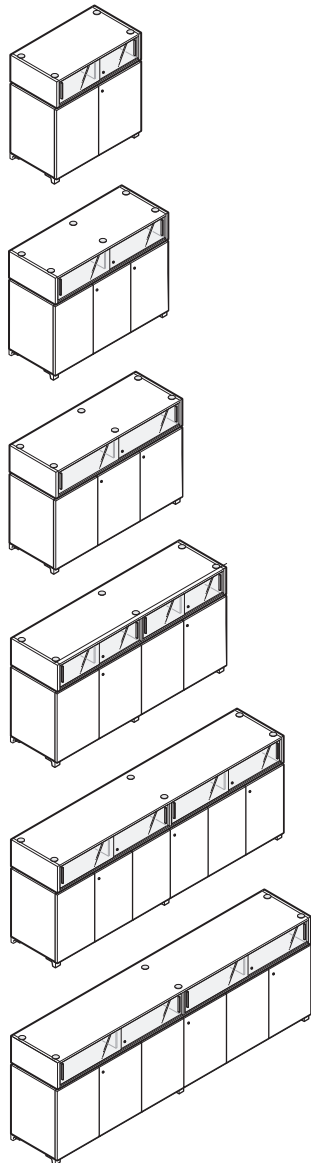

GAC2

Features

- Includes 29”(737mm) high base cabinet with two shelves, doors, legs and 10”(254mm) high upper slider unit with glass or acrylic slider doors, pulls and hardware.
- **Credenza top is ordered separately.**
- Laminate with 1mm edgeband or wood veneer with 1mm wood edgeband.
- Wood door fronts are matched veneer.
- 1/8”(3mm) reveal between base and slider unit and between slider unit and credenza top.
- Credenza available in standard core.
- Cabinet doors have touch latches.
- Slider unit doors are glass or translucent with painted aluminum bar pulls.
- Optional locks are available in black or chrome.
- For lock options refer to Lock Program Price List.
- Leg is 2 1/4”(57mm) high painted metal.
- Available with black glides only; 1 1/2”(38mm) height adjustment.
- Cabinet includes one adjustable shelf per cabinet with 1/4”(6mm) adjustment increments.
 - 36”(914mm) wide has two doors and four legs
 - 48”(1219mm) wide has three doors and four legs
 - 54”(1372mm) wide has three doors and four legs
 - 72”(1829mm) wide has four doors and six legs
 - 96”(2438mm) wide has six doors and six legs
 - 108”(2743mm) wide has six doors and six legs
- Ships unassembled.

Specification Tip

- **Must order a 1 3/16”(30mm) thick credenza top separately.**

* Overall height includes credenza base legs, reveal, slider unit and separately specified credenza top.

To Order, Specify:

- 1) Product number, including:

① Locking Option:

- N** Non-locking
- A** All locking, add \$132.75 list
- L** Slider unit locking only, add \$66.28 list

- 2) Laminate surface color or wood finish color.
- 3) Edge trim color for laminate.
- 4) Leg and slider pull trim color.
- 5) Slider unit glass/translucent door.
- 6) Lock plug trim color.
 - Black – LR-BL
 - Chrome – LR-BP

Note: \$45.78 upcharge (list) for Metallic trim colors.

Planes Credenza Base with Slider Unit — 45" High

Overall Height*	Depth	Width	Number	①	Glass A	C	D	F	Translucent
Credenza Base – 45" (1143mm) High with Slider Unit – Laminate or Wood									
Laminate – Grade A									
45" (1143mm)	20" (508mm)	36" (914mm)	GAC2-2036-LGSN	G9	\$ 2451.96	\$ 2855.08	\$ 2915.32	\$ 3037.11	\$ 2653.53
		48" (1219mm)	GAC2-2048-LGSN	G9	3264.62	3802.18	3882.84	4044.83	3532.57
		54" (1372mm)	GAC2-2054-LGSN	G9	3670.95	4275.73	4366.60	4548.69	3972.09
		72" (1829mm)	GAC2-2072-LGSN	G9	4889.94	5696.38	5817.88	6060.27	5290.65
		96" (2438mm)	GAC2-2096-LGSN	G9	6515.26	7590.58	7752.92	8075.71	7048.73
		108" (2743mm)	GAC2-20A8-LGSN	G9	7327.92	8537.68	8720.44	9083.43	7927.77
Laminate – Grade B									
45" (1143mm)	20" (508mm)	36" (914mm)	GAC2-2036-LGSN	G9	\$ 2592.07	\$ 2995.19	\$ 3055.43	\$ 3177.22	\$ 2793.64
		48" (1219mm)	GAC2-2048-LGSN	G9	3450.97	3988.53	4069.19	4231.18	3718.92
		54" (1372mm)	GAC2-2054-LGSN	G9	3880.42	4485.20	4576.07	4758.16	4181.56
		72" (1829mm)	GAC2-2072-LGSN	G9	5168.77	5975.21	6096.71	6339.10	5569.48
		96" (2438mm)	GAC2-2096-LGSN	G9	6886.57	7961.89	8124.23	8447.02	7420.04
		108" (2743mm)	GAC2-20A8-LGSN	G9	7745.47	8955.23	9137.99	9500.98	8345.32
Wood Group A									
45" (1143mm)	20" (508mm)	36" (914mm)	GAC2-2036-WGSN	G9	\$ 3799.02	\$ 4202.14	\$ 4262.38	\$ 4384.17	\$ 4000.59
		48" (1219mm)	GAC2-2048-WGSN	G9	4977.94	5515.50	5596.16	5758.15	5245.89
		54" (1372mm)	GAC2-2054-WGSN	G9	5567.40	6172.18	6263.05	6445.14	5868.54
		72" (1829mm)	GAC2-2072-WGSN	G9	7335.78	8142.22	8263.72	8506.11	7736.49
		96" (2438mm)	GAC2-2096-WGSN	G9	9693.62	10768.94	10931.28	11254.07	10227.09
		108" (2743mm)	GAC2-20A8-WGSN	G9	10872.54	12082.30	12265.06	12628.05	11472.39
Wood Group B									
45" (1143mm)	20" (508mm)	36" (914mm)	GAC2-2036-WGSN	G9	\$ 3880.13	\$ 4283.25	\$ 4343.49	\$ 4465.28	\$ 4081.70
		48" (1219mm)	GAC2-2048-WGSN	G9	5080.93	5618.49	5699.15	5861.14	5348.88
		54" (1372mm)	GAC2-2054-WGSN	G9	5681.33	6286.11	6376.98	6559.07	5982.47
		72" (1829mm)	GAC2-2072-WGSN	G9	7482.53	8288.97	8410.47	8652.86	7883.24
		96" (2438mm)	GAC2-2096-WGSN	G9	9884.13	10959.45	11121.79	11444.58	10417.60
		108" (2743mm)	GAC2-20A8-WGSN	G9	11084.93	12294.69	12477.45	12840.44	11684.78

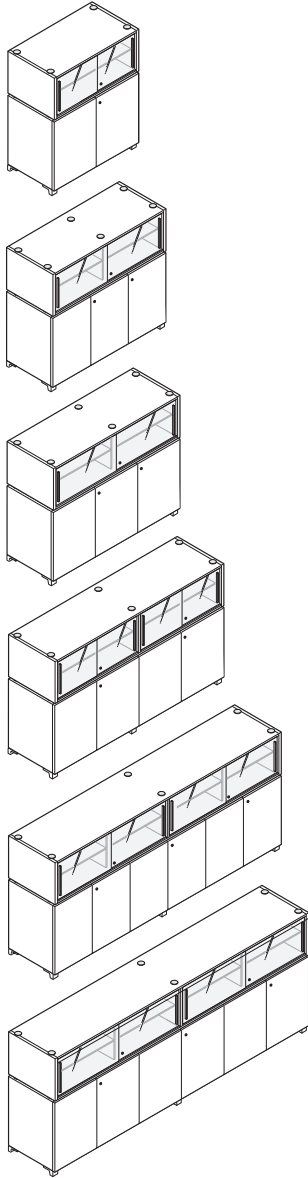

GAC2

Features

- Includes 29" (737mm) high base cabinet with two shelves, doors, legs and 16" (406mm) high upper slider unit with one shelf, glass or translucent slider doors, pulls and hardware.
- Credenza top is ordered separately.**
- Laminate with 1mm edgeband or wood veneer with 1mm wood edgeband.
- 1/8" (3mm) reveal between base and slider unit and between slider unit and credenza top.
- Credenza available in standard core.
- Cabinet doors have touch latches.
- Slider unit doors are glass or translucent with painted aluminum bar pulls.
- Optional locks are available in black or chrome.
- Lock plugs and keys are shipped with random numbering unless specified as keyed-alike or master-keyed.
- Leg is 2 1/4" (57mm) high painted metal.
- Available with black glides only; 1 1/2" (38mm) height adjustment.
- Slider unit includes one adjustable shelf per unit.
- Cabinet includes one adjustable shelf per cabinet with 1 1/4" (32mm) adjustment increments.
 - 36" (914mm) wide has two doors and four legs
 - 48" (1219mm) wide has three doors and four legs
 - 54" (1372mm) wide has three doors and four legs
 - 72" (1829mm) wide has four doors and six legs
 - 96" (2438mm) wide has six doors and six legs
 - 108" (2743mm) wide has six doors and six legs
- Ships unassembled.

Specification Tip

- Must order a 1 3/16" (30mm) thick credenza top separately.**

* Overall height includes credenza base legs, reveal, slider unit and separately specified credenza top.

To Order, Specify:

- Product number, including:

① Locking Option:

- N** Non-locking
- A** All locking, add \$132.75 list
- L** Slider unit locking only, add \$66.28 list

- Laminate surface color or wood finish color.
- Edge trim color for laminate.
- Leg and slider pull trim color.
- Slider unit glass/translucent door.
- Lock plug trim color.
 - Black – LR-BL
 - Chrome – LR-BP

Note: \$45.78 upcharge (list) for Metallic trim color.

Planes Credenza Tops

Credenza Top – Laminate or Wood

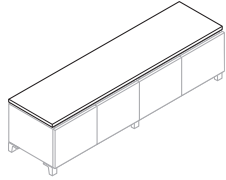

GACJ

Depth	Width	Number	Laminate		Wood Group A	Group B
			A	B		
Laminate						
20"(508mm)	36"(914mm)	GACJ-2036-LJSNNNN	\$299.89	\$ 368.72		
	48"(1219mm)	GACJ-2048-LJSNNNN	400.67	481.06		
	54"(1372mm)	GACJ-2054-LJSNNNN	451.06	537.23		
	72"(1829mm)	GACJ-2072-LJSNNNN	602.23	705.74		
	96"(2438mm)	GACJ-2096-LJSNNNN	803.79	930.42		
	108"(2743mm)	GACJ-20A8-LJSNNNN	904.57	1042.76		
Wood						
20"(508mm)	36"(914mm)	GACJ-2036-WKSNNNN			\$ 481.79	\$ 492.56
	48"(1219mm)	GACJ-2048-WKSNNNN			641.57	661.78
	54"(1372mm)	GACJ-2054-WKSNNNN			721.46	746.39
	72"(1829mm)	GACJ-2072-WKSNNNN			961.13	1000.22
	96"(2438mm)	GACJ-2096-WKSNNNN			1280.69	1338.66
	108"(2743mm)	GACJ-20A8-WKSNNNN			1440.47	1507.88

Features

- Includes one 1 3/16"(30mm) thick credenza top and hardware for use on Planes credenza bases.
- Laminate with 1mm edgeband or wood veneer with 1mm wood edgeband.
- Credenza top available in standard core.
- Top installs on credenza base with 1/4"(6mm) reveal.

To Order, Specify:

- 1) Product number.
- 2) Laminate surface color or wood finish color.
- 3) Edge trim color for laminate.

Specification Tip

- **Must be used with credenza base for finished aesthetic.**

Grommet



TA01

Top Thickness	Diameter	Number	Price
3/4"(19mm)	2 3/4"(70mm)	TA01-0220	\$31.95

Features

- Includes one grommet.
- Field installed into field cut opening.

To Order, Specify:

- 1) Product number.
- 2) Trim color.

Note: \$4.92 upcharge list for Metallic and accent trim colors.

Planes Conference Tables — Column Base (for use with Conference Table Top and End Supported Top)

Column Frame

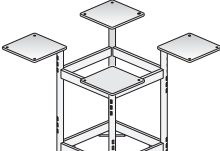
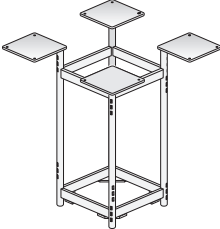
	Height	Depth	Width	Number	Price
	20"(508mm)	21"(533mm)	9"(229mm)	TACB-0900-2	\$924.66
		24"(610mm)	12"(305mm)	TACB-1200-2	935.80
TACB-2	28"(711mm)	21"(533mm)	9"(229mm)	TACB-0900-4	\$935.80
		24"(610mm)	12"(305mm)	TACB-1200-4	946.94
	40"(1016mm)	21"(533mm)	9"(229mm)	TACB-0900-7	\$980.36
		24"(610mm)	12"(305mm)	TACB-1200-7	991.50

Features

- Includes one black square column frame, glides and mounting hardware.
- Available in two widths, 9"(229mm) x 9"(229mm) or 12"(305mm) x 12"(305mm), and three heights, 20"(508mm), 28"(711mm) or 40"(1016mm).
- Glide adjustment is 1/2" (13mm).
- For use with Planes Conference Table Top and End Supported Top.
- The quantity and width of the column frame is dependent on the top size.
- Requires separately specified cladding and column base plate (Exception: base plate is optional for End Supported Top.)

To Order, Specify:

- 1) Product number.
(No finish specification required.)

Specification Tips

- For workware at lounge height wireless is recommended.
- Specify cladding to match column frame height and width.
- Specify column base plate to match column frame width.
- For separately specified required components refer to the **Component Specification Overview** located in the front of the price list.

TACB-2

TACB-4

TACB-7

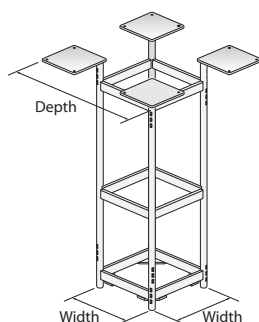

Planes Conference Table — Column Base (for use with Conference Table Top and End Supported Top)

Column Base Plate — Square and Round

Size	For use with Column Frame Width	Number	Paint A	B
Square				
21"(533mm)	9"(229mm)	TAPL-2109-SA	\$584.87	\$597.12
24"(610mm)	9"(229mm)	TAPL-2409-SA	\$696.27	\$708.52
	12"(305mm)	TAPL-2412-SA	696.27	708.52
27"(686mm)	12"(305mm)	TAPL-2712-SA	\$807.68	\$819.93
Round				
21"(533mm)	9"(229mm)	TAPL-2109-RA	\$529.17	\$541.42
24"(610mm)	9"(229mm)	TAPL-2409-RA	\$640.57	\$652.82
	12"(305mm)	TAPL-2412-RA	640.57	652.82
27"(686mm)	12"(305mm)	TAPL-2712-RA	\$751.98	\$764.23
30"(762mm)	12"(305mm)	TAPL-3012-RA	\$974.79	\$987.04

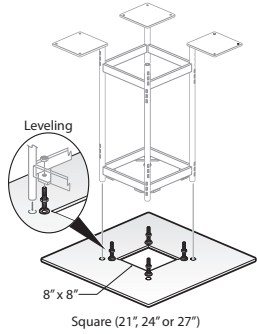

TAPL-S

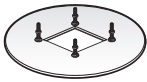

Round (21", 24" or 27" dia.)
TAPL-R

Features

- Includes 3/8" thick square or round column base plate with attached glides.
- A base plate with a 8"(203mm)x 8"(203mm) cutout accepts a 12"(305mm) column frame; base plate with a 6"(152mm) x 6"(152mm) cutout accepts a 9"(229mm) column frame.
- Column base plate attachment hardware is included with the column frame.
- The column base plate levels by adjusting the attachment hardware; 0.75"(19mm) adjustment range.
- Available in a painted finish.

To Order, Specify:

- 1) Product number:
- 2) Paint surface color.

Specification Tips

- Specify the appropriate column base plate size for use with a 9"(229mm) or 12"(305mm) column frame width.
- For use with separately specified column frame and cladding.
- Column Base Plate is required for Planes Conference Table Top and is optional for End Supported Top.
- For separately specified required components refer to the **Component Specification Overview** located in the front of the price list.

Planes Conference Table — Column Base (for use with Conference Table Top and End Supported Top)

Cladding — Flat and Round

Frame Height	Frame Width	Number ①	Paint		Wood Group A	Group B
			A	B		
Flat						
20"(508mm)	9"(229mm)	TACC-0900- F2	\$256.24	\$261.81	\$590.45	\$598.25
	12"(305mm)	TACC-1200- F2	267.38	272.95	601.59	609.95
28"(711mm)	9"(229mm)	TACC-0900- F4	\$267.38	\$272.95	\$601.59	\$609.39
	12"(305mm)	TACC-1200- F4	278.52	284.09	612.73	621.09
40"(1016mm)	9"(229mm)	TACC-0900- F7	\$278.52	\$284.09	\$612.73	\$620.53
	12"(305mm)	TACC-1200- F7	289.66	295.23	623.87	632.23
Round						
20"(508mm)	9"(229mm)	TACC-0900- R2	\$267.38	\$272.95	\$601.59	\$609.39
	12"(305mm)	TACC-1200- R2	278.52	284.09	612.73	621.09
28"(711mm)	9"(229mm)	TACC-0900- R4	\$278.52	\$284.09	\$612.73	\$620.53
	12"(305mm)	TACC-1200- R4	289.66	295.23	623.87	632.23

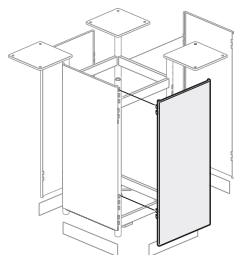

TACC-F2

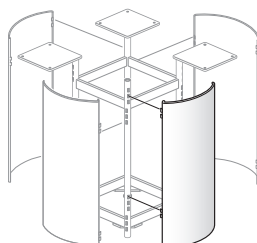

TACC-R2

Features

- Includes one piece painted or wood veneer cladding and light block for a square column frame .
- Each square column frame requires a quantity of four: flat, round or a combination of flat and round.
- Flat cladding is available in three heights 20"(508mm), 28"(711mm) or 40"(1016mm) and two widths 9"(229mm) or 12"(305mm).
- Round Cladding is available in two heights 20"(508mm) or 28"(711mm) and two widths 9"(229mm) or 12"(305mm).
- Attaches in column frame slots and is removable for easy access.
- Cladding is steel and available painted or veneer wrapped.

Specification Tips

- Specify cladding to match column frame height and width.
- Specify a quantity of (4) cladding pieces for each column frame. Individual pieces may be all flat, all round, or a combination of flat and round pieces. Surfaces may be all paint, all wood veneer or mixed surfaces.
- Specify column base plate to match column frame width.
- For separately specified required components refer to the **Component Specification Overview** located in the front of the price list.

To Order, Specify:

- 1) Product number, including:

① Surface Option:

- P** Paint
- W** Wood Veneer

- 2) Paint surface color or wood finish color.

Planes Conference Table — Column Base (for use with Conference Table Top)

J-Channels

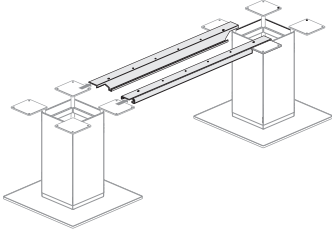
	Width	Number	Price
 TAJC	26"(660mm)	TAJC-2600	\$251.77
	29"(737mm)	TAJC-2900	281.03
	32"(813mm)	TAJC-3200	309.91
	35"(889mm)	TAJC-3500	338.79
	38"(965mm)	TAJC-3800	367.67
	41"(1041mm)	TAJC-4100	396.55
	44"(1118mm)	TAJC-4400	425.81
	47"(1194mm)	TAJC-4700	454.69
	50"(1270mm)	TAJC-5000	483.57
	53"(1346mm)	TAJC-5300	512.45
	56"(1422mm)	TAJC-5600	541.33
	59"(1499mm)	TAJC-5900	570.59
	62"(1575mm)	TAJC-6200	599.47
	65"(1651mm)	TAJC-6500	628.35
	68"(1727mm)	TAJC-6800	657.23
	71"(1803mm)	TAJC-7100	686.11
	74"(1880mm)	TAJC-7400	715.37
	77"(1956mm)	TAJC-7700	744.25
	80"(2032mm)	TAJC-8000	773.13
	83"(2108mm)	TAJC-8300	802.01
	86"(2184mm)	TAJC-8600	830.89
89"(2261mm)	TAJC-8900	860.15	
92"(2337mm)	TAJC-9200	889.03	
95"(2413mm)	TAJC-9500	917.91	
98"(2489mm)	TAJC-9800	946.79	
101"(2565mm)	TAJC-A100	975.67	

Features

- Includes one pair of J-Channels and mounting hardware.
- Provides wire management and support below the Conference Table Top.
- Attaches to the underside of the Conference Table Top with screws.
- The Conference Table Top width and the column frame size determines the J-Channel width.
- Field-installed.
- Available in black finish color only.

To Order, Specify:

- 1) Product number.
(No finish specification required.)

Specification Tips

- J-Channels are required for Planes Conference Table Top.
- J-Channels are not required for Planes End Supported Tops.
- For separately specified required components refer to the **Component Specification Overview** located in the front of the price list.

J-Channel Tray

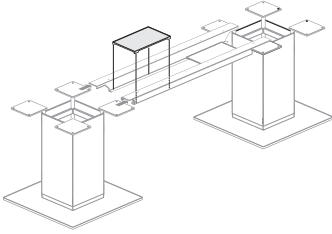
 TA01	9"(229mm)	TA01-JT09	\$11.14
	12"(305mm)	TA01-JT12	11.14

Features

- Includes one J-Channel Tray.
- Provides additional wire management between columns; wires lay in J-Channels.
- Field-installed.
- Available in black finish color only.

To Order, Specify:

- 1) Product number.
(No finish specification required.)

Specification Tips

- J-Channel Tray is an optional component.
- Specify the appropriate size for use with a 9"(229mm) or 12"(305mm) wide column frame.

This page intentionally blank

Planes Conference Tables — Interior Leg — Laminate

Round, Square, Rectangular

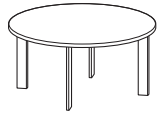

TARN

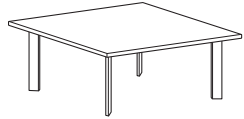

TARQ

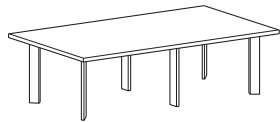

TARA

Features

- Includes 1 3/16" (30mm) top, interior leg bases and hardware.
- Standard table height is 29" (737mm).
- Laminate top with 3mm edgeband or knife edges based upon shape.
- 3mm edgeband or knife edge not available on 42" (1067mm)-60" (1524mm) round tables.
- Table top seams are 1mm edgeband on two piece tops.
- Interior legs are painted aluminum.
- Interior leg is 1 1/8" (29mm) x 3 1/4" (83mm).
- Optional Flip top unit electrical modules are separately specified. Refer to electrical components for appropriate product specification.
- Optional cable base can be specified for tables 36" (914mm) deep and deeper:
 - 36" (914mm) deep tables will ship with 8" (203mm) x 14" (356mm) cable base.
 - 42" (1067mm) deep and deeper tables will ship with 14" (356mm) x 14" (356mm) cable base.
 - One piece tops will include one cable base to be centered under table top.
 - Two piece tops will include one cable base to be centered on seams under table top.
 - Cable base and table top(s) are laminate and can be specified in different surface colors and edge trim colors.
 - Optional Cable Base may reduce number of legs shipped with product.
 - Refer to Specification Guide for use guidelines and details.
- Available with glides only; 1/2" (13mm) height adjustment.
- Depth and width shown in nominal dimensions.
- Ships unassembled.

Specification Tips

- Cable base not recommended for 30" (762mm) deep tables.
- Cable base for 36" (914mm) deep table is not compatible with Fliptop Cutout Options (M) and (Q).
- Tables with multiple-piece tops have equal sized pieces.
- The following Planes products are separately specified:
 - Grommets (field cut opening)
 - Flip top unit electrical modules
 - Horizontal wire manager
- Refer to Specification Guide for seating capacities with Cable Base Option and leg locations.

To Order, Specify:

1) Product number, including:

① Edge Option:

- J** Edgeband
- F** Knife

② Flip top unit Cutout(s):

Cutout options **F, J, M, Q**:
add **\$33.13** list for one-piece top;
add **\$66.26** list for two-piece tops.

- N** None
- F** Center – single-sided/4 outlets
- J** Center – single-sided/6 outlets
- M** Center – double-sided/8 outlets
- Q** Center – double-sided/12 outlets

③ Cable Base Option:

- N** None
- C** Cable Base:
add **\$662.73** list for 36" deep tables;
add **\$698.87** list for 42" deep and deeper tables

- 2) Laminate surface color.
- 3) 1mm edgeband trim color. (Cascade edge/multiple-tops only)*
- 4) Edge trim color.
- 5) Base trim color.
- 6) Laminate surface – Cable Base
- 7) Edge trim color – Cable Base

Note: **\$45.78** upcharge (list) for Metallic and accent trim colors.

Planes Conference Tables — Interior Leg — Laminate

Round, Square, Rectangular

No. of Pieces	No. of Legs	Seating Capacity*	Depth	Width	Number ① ② ③	Laminate A		Laminate B		
						J	F	J	F	
Round										
1	4	4	42"(1067mm)	42"(1067mm)	TARN-4242-L S JG4N	\$ 770.28	\$1020.20	\$ 838.76	\$1088.68	
1	4	4	48"(1219mm)	48"(1219mm)	TARN-4848-L S JG4N	956.43	1236.11	1045.31	1324.99	
1	4	4	54"(1372mm)	54"(1372mm)	TARN-5454-L S JG4N	1166.44	1475.88	1278.44	1587.88	
1	4	4	60"(1524mm)	60"(1524mm)	TARN-6060-L S JG4N	1400.31	1739.51	1538.15	1877.35	
2	6	6	66"(1676mm)	66"(1676mm)	TARN-6666-L S JG4	\$2068.98	\$2509.16	\$2235.38	\$2675.56	
2	6	6	72"(1829mm)	72"(1829mm)	TARN-7272-L S JG4	2428.84	2898.78	2626.52	3096.46	
Square										
1	4	4	42"(1067mm)	42"(1067mm)	TARQ-4242-L S JG4N	\$ 770.28	\$1020.20	\$ 838.76	\$1088.68	
1	4	4	48"(1219mm)	48"(1219mm)	TARQ-4848-L S JG4N	956.43	1236.11	1045.31	1324.99	
1	4	4	54"(1372mm)	54"(1372mm)	TARQ-5454-L S JG4N	1166.44	1475.88	1278.44	1587.88	
1	4	8	60"(1524mm)	60"(1524mm)	TARQ-6060-L S JG4N	1400.31	1739.51	1538.15	1877.35	
2	6	8	66"(1676mm)	66"(1676mm)	TARQ-6666-L S JG4	\$2068.98	\$2477.58	\$2235.38	\$2643.98	
2	6	8	72"(1829mm)	72"(1829mm)	TARQ-7272-L S JG4	2428.84	2867.20	2626.52	3064.88	
Rectangular										
1	4	4	30"(762mm)	60"(1524mm)	TARA-3060-L S JG4N	\$ 822.43	\$1083.63	\$ 891.60	\$1152.80	
1	4	4		66"(1676mm)	TARA-3066-L S JG4N	885.27	1161.11	961.39	1237.23	
1	6	4		72"(1829mm)	TARA-3072-L S JG4N	948.11	1238.59	1031.18	1321.66	
1	4	4	36"(914mm)	60"(1524mm)	TARA-3660-L S JG4	\$ 945.47	\$1221.31	\$1028.54	\$1304.38	
1	4	4		66"(1676mm)	TARA-3666-L S JG4	1020.35	1310.83	1111.76	1402.24	
1	4	4	42"(1067mm)	48"(1219mm)	TARA-4248-L S JG4	\$ 894.67	\$1155.87	\$ 972.18	\$1233.38	
1	4	4		54"(1372mm)	TARA-4254-L S JG4	981.59	1257.43	1068.83	1344.67	
1	4	4		60"(1524mm)	TARA-4260-L S JG4	1068.51	1358.99	1165.48	1455.96	
1	4	6		66"(1676mm)	TARA-4266-L S JG4	1155.43	1460.55	1262.13	1567.25	
1	6	6		72"(1829mm)	TARA-4272-L S JG4	1242.35	1562.11	1358.78	1678.54	
1	6	6		78"(1981mm)	TARA-4278-L S JG4	1329.27	1663.67	1455.43	1789.83	
1	4	4	48"(1219mm)	54"(1372mm)	TARA-4854-L S JG4	\$1092.59	\$1383.07	\$1192.34	\$1482.82	
1	4	4		60"(1524mm)	TARA-4860-L S JG4	1191.55	1496.67	1302.42	1607.54	
1	4	6		66"(1676mm)	TARA-4866-L S JG4	1290.51	1610.27	1412.50	1732.26	
1	6	6		72"(1829mm)	TARA-4872-L S JG4	1389.47	1723.87	1522.58	1856.98	
1	6	8		78"(1981mm)	TARA-4878-L S JG4	1488.43	1837.47	1632.66	1981.70	
1	4	4	54"(1372mm)	60"(1524mm)	TARA-5460-L S JG4	\$1314.59	\$1634.35	\$1439.36	\$1759.12	
1	4	6		66"(1676mm)	TARA-5466-L S JG4	1425.59	1759.99	1562.87	1897.27	
1	6	6		72"(1829mm)	TARA-5472-L S JG4	1536.59	1885.63	1686.38	2035.42	
1	6	6		78"(1981mm)	TARA-5478-L S JG4	1647.59	2011.27	1809.89	2173.57	
1	4	8	60"(1524mm)	66"(1676mm)	TARA-6066-L S JG4	\$1560.67	\$1909.71	\$1713.24	\$2062.28	
1	6	8		72"(1829mm)	TARA-6072-L S JG4	1683.71	2047.39	1850.18	2213.86	
1	6	8		78"(1981mm)	TARA-6078-L S JG4	1806.75	2185.07	1987.12	2365.44	

*Recommended seating capacity based upon 27"(686mm) per chair.

Planes Conference Tables — Interior Leg — Laminate

Half Round

No. of Pieces	No. of Legs	Depth	Width	Number ① ②	Laminate A		Laminate B	
					J	F	J	F
1	4	30"(762mm)	60"(1524mm)	TAHN-3060-L S JG4N	\$ 816.00	\$1084.44	\$ 884.83	\$1153.27
1	4	36"(914mm)	72"(1829mm)	TAHN-3672-L S JG4N	1086.60	1401.68	1185.35	1500.43

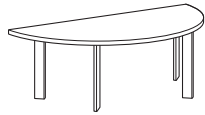

TAHN

Features

- Includes 1 3/16"(30mm) thick top, interior leg bases and hardware.
- Standard table height is 29"(737mm).
- Laminate top with 3mm edgeband or knife edges.
- Bases are painted aluminum.
- Optional Flip top unit electrical modules are separately specified. Refer to electrical components for appropriate product specification.
- Available with glides only; 1/2"(13mm) height adjustment.
- Depth and width shown in nominal dimensions.
- Ships unassembled.

Specification Tips

- Cable base not recommended for half round tables.
- 3mm edgeband edge is recommended to allow a flat seam between tables.
- Width is meant to accommodate two 30"(762mm) or 36"(914mm) deep rectangular tables.
- The following Planes products are separately specified:
 - Grommets (field cut opening)
 - Flip top unit electrical modules
 - Horizontal wire manager
- Refer to Specification Guide for leg locations.

To Order, Specify:

1) Product number, including:

① Edge Option:

- J** Edgeband
- F** Knife

② Flip Top Unit Cutout(s):

- N** None
- F** Center – single sided/4 outlets, add **\$33.13** list
- J** Center – single-sided/6 outlets, add **\$33.13** list

2) Laminate surface color.

3) Edge trim color.

4) Base trim color.

Note: **\$45.78** upcharge (list) for Metallic and accent trim colors.

Planes Conference Tables — Interior Leg — Laminate

Polygon

No. of Pieces	No. of Legs	Depth	Width	Number ① ②	Laminate A		Laminate B	
					J	F	J	F
1	5	30"(762mm)	60"(1524mm)	TACV-3060-L S JG4N	\$ 818.71	\$1081.83	\$ 887.88	\$1151.00
1	5	36"(914mm)	72"(1829mm)	TACV-3672-L S JG4N	1090.72	1397.86	1190.47	1497.61

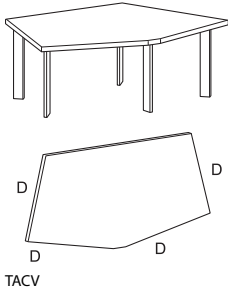
**Features**

- Includes 1 3/16"(30mm) thick top, interior leg bases and hardware.
- Standard table height is 29"(737mm).
- Laminate top with 3mm edgeband or knife edges.
- Bases are painted aluminum.
- Optional Flip Top unit electrical modules are separately specified. Refer to electrical components for appropriate product specification.
- Available with glides only; 1/2"(13mm) height adjustment.
- Depth and width shown in nominal dimensions.
- Ships unassembled.

Specification Tips

- Cable base not recommended for polygon table.
- 3mm edgeband edge is recommended to allow a flat seam between tables.
- Depth matches 30"(762mm) or 36"(914mm) deep rectangular tables.
- The following Planes products are separately specified:
 - Grommets (field cut opening)
 - Flip top unit electrical modules
 - Horizontal wire manager
- Refer to Specification Guide for leg locations.

To Order, Specify:

- 1) Product number, including:

① Edge Option:

- J** Edgeband
- F** Knife

② Flip Top Unit Cutout(s):

- N** None
- F** Center – single-sided/4 outlets, add **\$33.13** list
- J** Center – single-sided/6 outlets, add **\$33.13** list

- 2) Laminate surface color.

- 3) Edge trim color.

- 4) Base trim color.

Note: **\$45.78** upcharge (list) for Metallic and accent trim colors.

Planes Conference Tables — Interior Leg — Wood

Round, Square, Rectangular

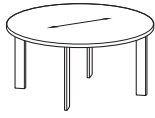

TARN



TARQ

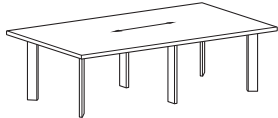

TARA

Features

- Includes 1 3/16" (30mm) top, interior leg bases and hardware.
- Standard table height is 29" (737mm).
- Wood veneer top with wood edgeband or knife edge.
- Table top seams are 1mm edge band on two piece tops.
- Interior legs are painted aluminum.
- Interior leg is 1 1/8" (29mm) x 3 1/4" (83mm).
- Optional cable base can be specified for tables 36" (914mm) deep and deeper:
 - 36" (914mm) deep tables will ship with 8" (203mm) x 14" (356mm) cable base.
 - 42" (1067mm) deep and deeper tables will ship with 14" (356mm) x 14" (356mm) cable base.
 - One piece tops will include one cable base to be centered under table top.
 - Two piece tops will include one cable base to be centered on seams under table top.
 - Cable base and table top(s) are wood veneer and can be specified in different surface colors and edge trim colors.
 - Refer to Specification Guide for use guidelines and details.
- Optional Flip top unit electrical modules are separately specified. Refer to electrical components for appropriate product specification.
- Available with glides only; 1/2" (13mm) height adjustment.
- Depth and width shown in nominal dimensions.
- Ships unassembled.

Specification Tips

- Cable base not recommended for 30" (762mm) deep tables.
- Tables with multiple-piece tops have equal sized pieces.
- The following Planes products are separately specified:
 - Grommets (field cut opening)
 - Flip top unit electrical modules
 - Horizontal wire manager
- Refer to Specification Guide for seating capacities with Cable Base Option and leg locations.

To Order, Specify:

1) Product number, including:

① Edge Option:

- K** Edgeband
- U** Knife

② Flip Top Unit Cutout(s):

Cutout options **F, J, M, Q**:
add **\$33.13** list for one-piece top;
add **\$66.26** list for two-piece tops.

- N** None
- F** Center – single-sided/4 outlets
- J** Center – single-sided/6 outlets
- M** Center – double-sided/8 outlets
- Q** Center – double-sided/12 outlets

③ Cable Base Option:

- N** None
- C** Cable Base:
add **\$662.73** list for 36" deep tables;
add **\$698.87** list for 42" deep and deeper tables

- 2) Wood finish color.
- 3) Base trim color.
- 4) Wood finish color – Cable Base.

Note: **\$45.78** upcharge (list) for Metallic and accent trim colors.

Planes Conference Tables — Interior Leg — Wood

Round, Square, Rectangular

No. of Pieces	No. of Legs	Seating Capacity*	Depth	Width	Number	①	②	③	Wood Group A		Wood Group B	
									K	U	K	U
Round												
1	4	4	42"(1067mm)	42"(1067mm)	TARN-4242-W	S	JG4N		\$1158.78	\$1419.28	\$1184.76	\$1470.30
1	4	4	48"(1219mm)	48"(1219mm)	TARN-4848-W	S	JG4N		1425.69	1799.04	1467.96	1877.20
1	4	4	54"(1372mm)	54"(1372mm)	TARN-5454-W	S	JG4N		1897.35	2454.61	1957.89	2563.70
1	4	4	60"(1524mm)	60"(1524mm)	TARN-6060-W	S	JG4N		2261.92	2988.92	2342.71	3132.81
2	6	6	66"(1676mm)	66"(1676mm)	TARN-6666-W	S	JG4		\$3462.46	\$4376.14	\$3565.48	\$4558.58
2	6	6	72"(1829mm)	72"(1829mm)	TARN-7272-W	S	JG4		4152.27	5177.47	4279.50	5402.34
Square												
1	4	4	42"(1067mm)	42"(1067mm)	TARQ-4242-W	S	JG4N		\$1158.78	\$1419.28	\$1184.76	\$1470.30
1	4	4	48"(1219mm)	48"(1219mm)	TARQ-4848-W	S	JG4N		1425.69	1799.04	1467.96	1877.20
1	4	4	54"(1372mm)	54"(1372mm)	TARQ-5454-W	S	JG4N		1897.35	2454.61	1957.89	2563.70
1	4	8	60"(1524mm)	60"(1524mm)	TARQ-6060-W	S	JG4N		2261.92	2988.92	2342.71	3132.81
2	6	8	66"(1676mm)	66"(1676mm)	TARQ-6666-W	S	JG4		\$3462.46	\$4376.14	\$3565.48	\$4558.58
2	6	8	72"(1829mm)	72"(1829mm)	TARQ-7272-W	S	JG4		4152.27	5177.47	4279.50	5402.34
Rectangular												
1	4	4	30"(762mm)	60"(1524mm)	TARA-3060-W	S	JG4N		\$1195.42	\$1500.68	\$1273.32	\$1617.25
1	4	4		66"(1676mm)	TARA-3066-W	S	JG4N		1296.19	1632.16	1392.56	1771.92
1	6	4		72"(1829mm)	TARA-3072-W	S	JG4N		1397.24	1765.57	1512.14	1928.84
1	4	4	36"(914mm)	60"(1524mm)	TARA-3660-W	S	JG4		\$1383.48	\$1706.32	\$1495.37	\$1859.45
1	4	4		66"(1676mm)	TARA-3666-W	S	JG4		1502.29	1856.66	1635.88	2036.34
1	4	4	42"(1067mm)	48"(1219mm)	TARA-4248-W	S	JG4		\$1298.67	\$1579.31	\$1394.87	\$1710.15
1	4	4		54"(1372mm)	TARA-4254-W	S	JG4		1434.97	1744.68	1555.97	1904.78
1	4	4		60"(1524mm)	TARA-4260-W	S	JG4		1571.54	1911.96	1717.41	2101.65
1	4	6		66"(1676mm)	TARA-4266-W	S	JG4		1708.39	2081.16	1879.19	2300.77
1	6	6		72"(1829mm)	TARA-4272-W	S	JG4		1845.52	2252.28	2041.30	2502.13
1	6	6		78"(1981mm)	TARA-4278-W	S	JG4		1982.92	2425.32	2203.75	2705.74
1	4	4	48"(1219mm)	54"(1372mm)	TARA-4854-W	S	JG4		\$1604.99	\$1931.46	\$1756.75	\$2124.76
1	4	4		60"(1524mm)	TARA-4860-W	S	JG4		1759.60	2117.60	1939.46	2343.85
1	4	6		66"(1676mm)	TARA-4866-W	S	JG4		1914.49	2305.66	2122.50	2565.19
1	6	6		72"(1829mm)	TARA-4872-W	S	JG4		2069.66	2495.64	2305.89	2788.78
1	6	8		78"(1981mm)	TARA-4878-W	S	JG4		2225.10	2687.54	2489.61	3014.61
1	4	4	54"(1372mm)	60"(1524mm)	TARA-5460-W	S	JG4		\$2246.61	\$2622.18	\$2460.44	\$2884.99
1	4	6		66"(1676mm)	TARA-5466-W	S	JG4		2419.53	2829.10	2664.76	3128.55
1	6	6		72"(1829mm)	TARA-5472-W	S	JG4		2592.74	3037.94	2869.41	3374.36
1	4	6		78"(1981mm)	TARA-5478-W	S	JG4		2766.22	3248.70	3074.40	3622.42
1	4	8	60"(1524mm)	66"(1676mm)	TARA-6066-W	S	JG4		\$2655.26	\$3083.23	\$2937.70	\$3422.61
1	6	8		72"(1829mm)	TARA-6072-W	S	JG4		2846.51	3310.93	3163.62	3690.64
1	6	8		78"(1981mm)	TARA-6078-W	S	JG4		3038.02	3540.54	3389.88	3960.92

*Recommended seating capacity based upon 27"(686mm) per chair.

Planes Conference Tables — Interior Leg — Wood

Half Round

No. of Pieces	No. of Legs	Depth	Width	Number	Wood Group A		Wood Group B	
					K	U	K	U
1	4	30"(762mm)	60"(1524mm)	TAHN-3060-W S JG4N	\$1208.80	\$1461.19	\$1232.28	\$1498.58
1	4	36"(914mm)	72"(1829mm)	TAHN-3672-W S JG4N	1691.92	1987.65	1717.82	2030.32

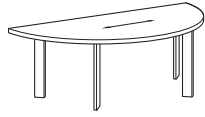

TAHN

Features

- Includes 1 3/16"(30mm) thick top, interior leg bases and hardware.
- Standard table height is 29"(737mm).
- Wood veneer top with 3mm wood edgeband or knife wood edge.
- Bases are painted aluminum.
- Optional Flip top unit electrical modules are separately specified. Refer to electrical components for appropriate product specification.
- Available with glides only; 1/2"(13mm) height adjustment.
- Depth and width shown in nominal dimensions.
- Ships unassembled.

Specification Tips

- Cable base not recommended for half round tables.
- 3mm edgeband edge is recommended to allow a flat seam between tables; refer to Specification Guide.
- Width is meant to accommodate two 30"(762mm) or 36"(914mm) deep rectangular tables.
- The following Planes products are separately specified:
 - Grommets (field cut opening)
 - Flip top unit electrical modules
 - Horizontal wire manager
- Refer to Specification Guide for leg locations.

To Order, Specify:

1) Product number, including:

1 Edge Option:

- K** Edgeband
- U** Knife

2 Flip Top Unit Cutout(s):

- N** None
- F** Center – single-sided/4 outlets, add **\$33.13** list
- J** Center – single-sided/6 outlets, add **\$33.13** list

2) Wood finish color.

3) Base trim color.

Note: **\$45.78** upcharge (list) for Metallic and accent trim colors.

Planes Conference Tables — Interior Leg — Wood

Polygon

No. of Pieces	No. of Legs	Depth	Width	Number	① ②		Wood Group A		Wood Group B	
					K	U	K	U		
1	5	30"(762mm)	60"(1524mm)	TACV-3060-W	S	JG4N	\$1213.41	\$1465.61	\$1238.83	\$1511.31
1	5	36"(914mm)	72"(1829mm)	TACV-3672-W	S	JG4N	1637.34	2020.31	1762.52	2169.80

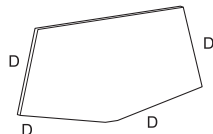
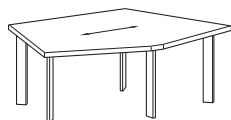

TACV

Features

- Includes 1 3/16"(30mm) thick top, interior leg bases and hardware.
- Standard table height is 29"(737mm).
- Wood veneer top with 3mm edgeband or knife wood edges
- Bases are painted aluminum.
- Optional Flip top unit electrical modules are separately specified. Refer to electrical components for appropriate product specification.
- Available with glides only; 1/2"(13mm) height adjustment.
- Depth and width shown in nominal dimensions.
- Ships unassembled.

Specification Tips

- Cable bases not recommended for polygon tables.
- 3mm edgeband edge is recommended to allow a flat seam between tables.
- Depth is meant to accommodate 30"(762mm) or 36"(914mm) deep rectangular tables.
- The following Planes products are separately specified:
 - Grommets (field cut opening)
 - Flip top unit electrical modules
 - Horizontal wire manager
- Refer to Specification Guide for leg locations.

To Order, Specify:

- 1) Product number, including:

① Edge Option:

- K** Edgeband
- U** Knife

② Flip Top Unit Cutout(s):

- N** None
- F** Center – single-sided/4 outlets, add **\$33.13** list
- J** Center – single-sided/6 outlets, add **\$33.13** list

- 2) Wood finish color.

- 3) Base trim color.

Note: **\$45.78** upcharge (list) for Metallic and accent trim colors.

Planes Conference Tables — One-Piece Top — Interior Leg — Laminate

Rectangular

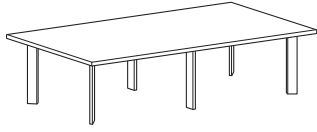

TARA

Features

- Includes 1 3/16" (30mm) thick top, interior leg bases and hardware.
- Standard table height is 29" (737mm).
- Laminate top with 3mm edgeband or knife edges based upon shape.
- Interior legs are painted aluminum.
- Interior leg is 1 1/8" (29mm) x 3 1/4" (83mm).
- Optional cable base can be specified for tables 36" (914mm) deep and deeper:
 - 36" (914mm) deep tables will ship with 8" (203mm) x 14" (356mm) cable base.
 - 42" (1067mm) deep and deeper tables will ship with 14" (356mm) x 14" (356mm) cable base.
 - One piece tops will include one cable base to be centered under table top.
 - Cable base and table top(s) are laminate and can be specified in different surface colors and edge trim colors.
 - Refer to Specification Guide for use guidelines.
- Optional Flip top unit electrical modules are separately specified. Refer to electrical components for appropriate product specification.
- Available with glides only; 1/2" (13mm) height adjustment.
- Depth and width shown in nominal dimensions.
- Ships unassembled.

Specification Tips

- Cable base for 36" (914mm) deep table is not compatible with Flip Top Cut Out Options (M) and (Q).
- The following Planes products are separately specified:
 - Grommets (field cut opening)
 - Flip top unit electrical modules
 - Horizontal wire management
- Refer to Specification Guide for seating capacities with Cable Base Option and leg locations.

To Order, Specify:

1) Product number, including:

① Edge Option:

- J** Edgeband
- F** Knife

② Flip Top Unit Cutout(s):

- N** None
- F** Center – single-sided/4 outlets, add **\$33.13** list
- V** Left/Right – single-sided/4 outlets, add **\$66.26** list
- J** Center – single-sided/6 outlets, add **\$33.13** list
- K** Left/Right – single-sided/6 outlets, add **\$66.26** list
- M** Center – double-sided/8 outlets, add **\$33.13** list
- P** Left/Right – double-sided/8 outlets, add **\$66.26** list
- Q** Center – double-sided/12 outlets, add **\$33.13** list
- T** Left/Right – double-sided/12 outlets, add **\$66.26** list

③ Cable Base Option:

- N** None
- C** Cable Base: add **\$662.73** list for 36" deep tables; add **\$698.87** list for 42" deep and deeper tables

- 2) Laminate surface color.
- 3) Edge trim color.
- 4) Base trim color.
- 5) Laminate surface – Cable Base
- 6) Edge trim color – Cable Base

Note: **\$45.78** upcharge (list) for Metallic and accent trim colors.

Planes Conference Tables — One-Piece Top — Interior Leg — Laminate

Rectangular

No. of Pieces	Seating Capacity*	Depth	Width	Number ① ② ③	Laminate A		Laminate B	
					J	F	J	F
6	6	36"(914mm)	72"(1829mm)	TARA-3672-L S JG4	\$1095.23	\$1400.35	\$1194.98	\$1500.10
6	6		78"(1981mm)	TARA-3678-L S JG4	1170.11	1489.87	1278.20	1597.96
6	6		84"(2134mm)	TARA-3684-L S JG4	1244.99	1579.39	1361.42	1695.82
6	8		90"(2286mm)	TARA-3690-L S JG4	1319.87	1668.91	1444.64	1793.68
6	8		96"(2438mm)	TARA-3696-L S JG4	1394.75	1758.43	1527.86	1891.54
6	6	42"(1067mm)	84"(2134mm)	TARA-4284-L S JG4	\$1416.19	\$1765.23	\$1552.08	\$1901.12
6	8		90"(2286mm)	TARA-4290-L S JG4	1503.11	1866.79	1648.73	2012.41
6	8		96"(2438mm)	TARA-4296-L S JG4	1590.03	1968.35	1745.38	2123.70
6	8		102"(2591mm)	TARA-42A2-L S JG4	1676.95	2069.91	1842.03	2234.99
6	10		108"(2743mm)	TARA-42A8-L S JG4	1763.87	2171.47	1938.68	2346.28
6	10		114"(2896mm)	TARA-42B4-L S JG4	1850.79	2273.03	2035.33	2457.57
6	10		120"(3048mm)	TARA-42C0-L S JG4	1937.71	2374.59	2131.98	2568.86
6	6	48"(1291mm)	84"(2134mm)	TARA-4884-L S JG4	\$1587.39	\$1951.07	\$1742.74	\$2106.42
6	8		90"(2286mm)	TARA-4890-L S JG4	1686.35	2064.67	1852.82	2231.14
6	8		96"(2438mm)	TARA-4896-L S JG4	1785.31	2178.27	1962.90	2355.86
6	8		102"(2591mm)	TARA-48A2-L S JG4	1884.27	2291.87	2072.98	2480.58
6	10		108"(2743mm)	TARA-48A8-L S JG4	1983.23	2405.47	2183.06	2605.30
6	10		114"(2896mm)	TARA-48B4-L S JG4	2082.19	2519.07	2293.14	2730.02
6	10		120"(3048mm)	TARA-48C0-L S JG4	2181.15	2632.67	2403.22	2854.74
6	8	54"(1372mm)	84"(2134mm)	TARA-5484-L S JG4	\$1758.59	\$2136.91	\$1933.40	\$2311.72
6	10		90"(2286mm)	TARA-5490-L S JG4	1869.59	2262.55	2056.91	2449.87
6	10		96"(2438mm)	TARA-5496-L S JG4	1980.59	2388.19	2180.42	2588.02
6	10		102"(2591mm)	TARA-54A2-L S JG4	2091.59	2513.83	2303.93	2726.17
6	10		108"(2743mm)	TARA-54A8-L S JG4	2202.59	2639.47	2427.44	2864.32
6	10		114"(2896mm)	TARA-54B4-L S JG4	2313.59	2765.11	2550.95	3002.47
6	10		120"(3048mm)	TARA-54C0-L S JG4	2424.59	2890.75	2674.46	3140.62
6	10	60"(1524mm)	84"(2134mm)	TARA-6084-L S JG4	\$1929.79	\$2322.75	\$2124.06	\$2517.02
6	10		90"(2286mm)	TARA-6090-L S JG4	2052.83	2460.43	2261.00	2668.60
6	10		96"(2438mm)	TARA-6096-L S JG4	2175.87	2598.11	2397.94	2820.18
6	10		102"(2591mm)	TARA-60A2-L S JG4	2298.91	2735.79	2534.88	2971.76
6	10		108"(2743mm)	TARA-60A8-L S JG4	2421.95	2873.47	2671.82	3123.34
6	10		114"(2896mm)	TARA-60B4-L S JG4	2544.99	3011.15	2808.76	3274.92
6	10		120"(3048mm)	TARA-60C0-L S JG4	2668.03	3148.83	2945.70	3426.50

*Recommended seating capacity based upon 27"(686mm) per chair.

Planes Conference Tables — One-Piece Top — Interior Leg — Laminate

Pebble

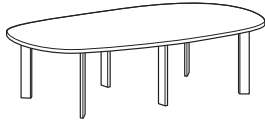

TARP

Features

- Includes 1 3/16" (30mm) thick top, interior leg bases and hardware.
- Standard table height is 29" (737mm).
- Laminate top with 3mm edgeband or knife edges.
- Top available in standard core.
- Interior legs are painted aluminum.
- Interior leg is 1 1/8" (29mm) x 3 1/4" (83mm).
- Optional cable base can be specified for tables 36" (914mm) deep and deeper:
 - 36" (914mm) deep tables will ship with 8" (203mm) x 14" (356mm) cable base.
 - 42" (1067mm) deep and deeper tables will ship with 14" (356mm) x 14" (356mm) cable base.
 - One piece tops will include one cable base to be centered under table top.
 - Cable base and table top(s) are laminate and can be specified in different surface colors and edge trim colors.
 - Refer to Specification Guide for use guidelines.
- Optional Flip top unit electrical modules are separately specified. Refer to electrical components for appropriate product specification.
- Available with glides only; 1/2" (13mm) height adjustment.
- Depth and width shown in nominal dimensions.
- Ships unassembled.

Specification Tips

- Cable base for 36" (914mm) deep table is not compatible with Flip Top Cut Out Options (M) and (Q).
- The following Planes products are separately specified:
 - Grommets (field cut grommet)
 - Flip top unit electrical modules
 - Horizontal wire management
- Refer to Specification Guide for seating capacities with Cable Base Option and leg locations.

To Order, Specify:

1) Product number, including:

① Edge Option:

- J** Edgeband
- F** Knife

② Flip Top Unit Cutout(s):

- N** None
- F** Center – single-sided/4 outlets, add **\$33.13** list
- V** Left/Right – single-sided/4 outlets, add **\$66.26** list
- J** Center – single-sided/6 outlets, add **\$33.13** list
- K** Left/Right – single-sided/6 outlets, add **\$66.26** list
- M** Center – double-sided/8 outlets, add **\$33.13** list
- P** Left/Right – double-sided/8 outlets, add **\$66.26** list
- Q** Center – double-sided/12 outlets, add **\$33.13** list
- T** Left/Right – double-sided/12 outlets, add **\$66.26** list

③ Cable Base Option:

- N** None
- C** Cable Base: add **\$662.73** list for 36" deep tables; add **\$698.87** list for 42" deep and deeper tables

- 2) Laminate surface color.
- 3) Edge trim color.
- 4) Base trim color.
- 5) Laminate surface – Cable Base
- 6) Edge trim color – Cable Base

Note: **\$45.78** upcharge (list) for Metallic and accent trim colors.

Planes Conference Tables — One-Piece Top — Interior Leg — Laminate

Pebble

No. of Legs	Seating Capacity*	Depth	Width	Number	①	②	③	Laminate A		Laminate B	
								J	F	J	F
4	6	36"(914mm)	72"(1829mm)	TARP-3672-L	S	JG4		\$1095.23	\$1400.35	\$1194.98	\$1500.10
6	6		78"(1981mm)	TARP-3678-L	S	JG4		1170.11	1489.87	1278.20	1597.96
6	6		84"(2134mm)	TARP-3684-L	S	JG4		1244.99	1579.39	1361.42	1695.82
6	8		90"(2286mm)	TARP-3690-L	S	JG4		1319.87	1668.91	1444.64	1793.68
6	8		96"(2438mm)	TARP-3696-L	S	JG4		1394.75	1758.43	1527.86	1891.54
6	6	42"(1067mm)	84"(2134mm)	TARP-4284-L	S	JG4		\$1416.19	\$1765.23	\$1552.08	\$1901.12
6	8		90"(2286mm)	TARP-4290-L	S	JG4		1503.11	1866.79	1648.73	2012.41
6	8		96"(2438mm)	TARP-4296-L	S	JG4		1590.03	1968.35	1745.38	2123.70
6	8		102"(2591mm)	TARP-42A2-L	S	JG4		1676.95	2069.91	1842.03	2234.99
6	10		108"(2743mm)	TARP-42A8-L	S	JG4		1763.87	2171.47	1938.68	2346.28
6	10		114"(2896mm)	TARP-42B4-L	S	JG4		1850.79	2273.03	2035.33	2457.57
6	10		120"(3048mm)	TARP-42C0-L	S	JG4		1937.71	2374.59	2131.98	2568.86
6	6	48"(1291mm)	84"(2134mm)	TARP-4884-L	S	JG4		\$1587.39	\$1951.07	\$1742.74	\$2106.42
6	8		90"(2286mm)	TARP-4890-L	S	JG4		1686.35	2064.67	1852.82	2231.14
6	8		96"(2438mm)	TARP-4896-L	S	JG4		1785.31	2178.27	1962.90	2355.86
6	8		102"(2591mm)	TARP-48A2-L	S	JG4		1884.27	2291.87	2072.98	2480.58
6	10		108"(2743mm)	TARP-48A8-L	S	JG4		1983.23	2405.47	2183.06	2605.30
6	10		114"(2896mm)	TARP-48B4-L	S	JG4		2082.19	2519.07	2293.14	2730.02
6	10		120"(3048mm)	TARP-48C0-L	S	JG4		2181.15	2632.67	2403.22	2854.74
6	8	54"(1372mm)	84"(2134mm)	TARP-5484-L	S	JG4		\$1758.59	\$2136.91	\$1933.40	\$2311.72
6	10		90"(2286mm)	TARP-5490-L	S	JG4		1869.59	2262.55	2056.91	2449.87
6	10		96"(2438mm)	TARP-5496-L	S	JG4		1980.59	2388.19	2180.42	2588.02
6	10		102"(2591mm)	TARP-54A2-L	S	JG4		2091.59	2513.83	2303.93	2726.17
6	10		108"(2743mm)	TARP-54A8-L	S	JG4		2202.59	2639.47	2427.44	2864.32
6	10		114"(2896mm)	TARP-54B4-L	S	JG4		2313.59	2765.11	2550.95	3002.47
6	10		120"(3048mm)	TARP-54C0-L	S	JG4		2424.59	2890.75	2674.46	3140.62
6	10	60"(1524mm)	84"(2134mm)	TARP-6084-L	S	JG4		\$1929.79	\$2322.75	\$2124.06	\$2517.02
6	10		90"(2286mm)	TARP-6090-L	S	JG4		2052.83	2460.43	2261.00	2668.60
6	10		96"(2438mm)	TARP-6096-L	S	JG4		2175.87	2598.11	2397.94	2820.18
6	10		102"(2591mm)	TARP-60A2-L	S	JG4		2298.91	2735.79	2534.88	2971.76
6	10		108"(2743mm)	TARP-60A8-L	S	JG4		2421.95	2873.47	2671.82	3123.34
6	10		114"(2896mm)	TARP-60B4-L	S	JG4		2544.99	3011.15	2808.76	3274.92
6	10		120"(3048mm)	TARP-60C0-L	S	JG4		2668.03	3148.83	2945.70	3426.50

*Recommended seating capacity based upon 27"(686mm) per chair.

Planes Conference Tables — One-Piece Top — Interior Leg — Laminate

Hexagon

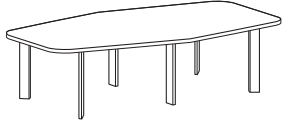

TARX

Features

- Includes 1 3/16" (30mm) thick top, interior leg bases and hardware.
- Standard table height is 29" (737mm).
- Laminate top with 3mm edgeband and knife edges.
- Top available in standard core.
- Interior legs are painted aluminum.
- Interior leg is 1 1/8" (29mm) x 3 1/4" (83mm).
- Optional cable base can be specified for tables 36" (914mm) deep and deeper:
 - 36" (914mm) deep tables will ship with 8" (203mm) x 14" (356mm) cable base.
 - 42" (1067mm) deep and deeper tables will ship with 14" (356mm) x 14" (356mm) cable base.
 - One piece tops will include one cable base to be centered under table top.
 - Cable base and table top(s) are laminate and can be specified in different surface colors and edge trim colors.
 - Refer to Specification Guide for use guidelines.
- Optional Flip top unit electrical modules are separately specified. Refer to electrical components for appropriate product specification.
- Available with glides only; 1/2" (13mm) height adjustment.
- Depth and width shown in nominal dimensions.
- Ships unassembled.

Specification Tips

- Cable base for 36" (914mm) deep table is not compatible with Flip Top Cut Out Options (M) and (Q).
- The following Planes products are separately specified:
 - Grommets (field cut opening)
 - Flip top unit electrical modules
 - Horizontal wire management
- Refer to Specification Guide for seating capacities with Cable Base Option and leg locations.

To Order, Specify:

1) Product number, including:

① Edge Option:

- J** Edgeband
- F** Knife

② Flip Top Unit Cutout(s):

- N** None
- F** Center – single-sided/4 outlets, add **\$33.13** list
- V** Left/Right – single-sided/4 outlets, add **\$66.26** list
- J** Center – single-sided/6 outlets, add **\$33.13** list
- K** Left/Right – single-sided/6 outlets, add **\$66.26** list
- M** Center – double-sided/8 outlets, add **\$33.13** list
- P** Left/Right – double-sided/8 outlets, add **\$66.26** list
- Q** Center – double-sided/12 outlets, add **\$33.13** list
- T** Left/Right – double-sided/12 outlets, add **\$66.26** list

③ Cable Base Option:

- N** None
- C** Cable Base: add **\$662.73** list for 36" deep tables; add **\$698.87** list for 42" deep and deeper tables

- 2) Laminate surface color.
- 3) Edge trim color.
- 4) Base trim color.
- 5) Laminate surface – Cable Base
- 6) Edge trim color – Cable Base

Note: **\$45.78** upcharge (list) for Metallic and accent trim colors.

Planes Conference Tables — One-Piece Top — Interior Leg — Laminate

Hexagon

No. of Legs	Seating Capacity*	Depth	Width	Number	①	②	③	Laminate A		Laminate B	
								J	F	J	F
4	6	36"(914mm)	72"(1829mm)	TARX-3672-L	S	JG4		\$1095.23	\$1400.35	\$1194.98	\$1500.10
6	6		78"(1981mm)	TARX-3678-L	S	JG4		1170.11	1489.87	1278.20	1597.96
6	6		84"(2134mm)	TARX-3684-L	S	JG4		1244.99	1579.39	1361.42	1695.82
6	8		90"(2286mm)	TARX-3690-L	S	JG4		1319.87	1668.91	1444.64	1793.68
6	8		96"(2438mm)	TARX-3696-L	S	JG4		1394.75	1758.43	1527.86	1891.54
6	6	42"(1067mm)	84"(2134mm)	TARX-4284-L	S	JG4		\$1416.19	\$1765.23	\$1552.08	\$1901.12
6	8		90"(2286mm)	TARX-4290-L	S	JG4		1503.11	1866.79	1648.73	2012.41
6	8		96"(2438mm)	TARX-4296-L	S	JG4		1590.03	1968.35	1745.38	2123.70
6	8		102"(2591mm)	TARX-42A2-L	S	JG4		1676.95	2069.91	1842.03	2234.99
6	10		108"(2743mm)	TARX-42A8-L	S	JG4		1763.87	2171.47	1938.68	2346.28
6	10		114"(2896mm)	TARX-42B4-L	S	JG4		1850.79	2273.03	2035.33	2457.57
6	10		120"(3048mm)	TARX-42C0-L	S	JG4		1937.71	2374.59	2131.98	2568.86
6	6	48"(1291mm)	84"(2134mm)	TARX-4884-L	S	JG4		\$1587.39	\$1951.07	\$1742.74	\$2106.42
6	8		90"(2286mm)	TARX-4890-L	S	JG4		1686.35	2064.67	1852.82	2231.14
6	8		96"(2438mm)	TARX-4896-L	S	JG4		1785.31	2178.27	1962.90	2355.86
6	8		102"(2591mm)	TARX-48A2-L	S	JG4		1884.27	2291.87	2072.98	2480.58
6	10		108"(2743mm)	TARX-48A8-L	S	JG4		1983.23	2405.47	2183.06	2605.30
6	10		114"(2896mm)	TARX-48B4-L	S	JG4		2082.19	2519.07	2293.14	2730.02
6	10		120"(3048mm)	TARX-48C0-L	S	JG4		2181.15	2632.67	2403.22	2854.74
6	8	54"(1372mm)	84"(2134mm)	TARX-5484-L	S	JG4		\$1758.59	\$2136.91	\$1933.40	\$2311.72
6	10		90"(2286mm)	TARX-5490-L	S	JG4		1869.59	2262.55	2056.91	2449.87
6	10		96"(2438mm)	TARX-5496-L	S	JG4		1980.59	2388.19	2180.42	2588.02
6	10		102"(2591mm)	TARX-54A2-L	S	JG4		2091.59	2513.83	2303.93	2726.17
6	10		108"(2743mm)	TARX-54A8-L	S	JG4		2202.59	2639.47	2427.44	2864.32
6	10		114"(2896mm)	TARX-54B4-L	S	JG4		2313.59	2765.11	2550.95	3002.47
6	10		120"(3048mm)	TARX-54C0-L	S	JG4		2424.59	2890.75	2674.46	3140.62
6	10	60"(1524mm)	84"(2134mm)	TARX-6084-L	S	JG4		\$1929.79	\$2322.75	\$2124.06	\$2517.02
6	10		90"(2286mm)	TARX-6090-L	S	JG4		2052.83	2460.43	2261.00	2668.60
6	10		96"(2438mm)	TARX-6096-L	S	JG4		2175.87	2598.11	2397.94	2820.18
6	10		102"(2591mm)	TARX-60A2-L	S	JG4		2298.91	2735.79	2534.88	2971.76
6	10		108"(2743mm)	TARX-60A8-L	S	JG4		2421.95	2873.47	2671.82	3123.34
6	10		114"(2896mm)	TARX-60B4-L	S	JG4		2544.99	3011.15	2808.76	3274.92
6	10		120"(3048mm)	TARX-60C0-L	S	JG4		2668.03	3148.83	2945.70	3426.50

*Recommended seating capacity based upon 27"(686mm) per chair.

Planes Conference Tables — One-Piece Top — Interior Leg — Wood

Rectangular

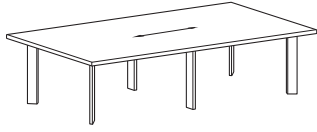

TARA

Features

- Includes 1 3/16" (30mm) thick top, interior leg bases and hardware.
- Standard table height is 29" (737mm).
- Top available in standard core.
- Wood veneer top with 3mm wood edgeband or knife wood edge.
- Interior legs are painted aluminum.
- Interior leg is 1 1/8" (29mm) x 3 1/4" (83mm).
- Optional cable base can be specified for tables 36" (914mm) deep and deeper:
 - 36" (914mm) deep tables will ship with 8" (203mm) x 14" (356mm) cable base.
 - 42" (1067mm) deep and deeper tables will ship with 14" (356mm) x 14" (356mm) cable base.
 - One piece tops will include one cable base to be centered under table top.
 - Cable base and table top(s) are wood veneer and can be specified in different surface colors and edge trim colors.
 - Refer to Specification Guide for use guidelines.
- Optional Flip top unit electrical modules are separately specified. Refer to electrical components for appropriate product specification.
- Available with glides only; 1/2" (13mm) height adjustment.
- Depth and width shown in nominal dimensions.
- Ships unassembled.

Specification Tips

- Cable base for 36" (914mm) deep table is not compatible with Flip Top Cut Out Options (M) and (Q).
- The following Planes products are separately specified:
 - Grommets (field cut opening)
 - Flip top unit electrical modules
 - Horizontal wire management
- Refer to Specification Guide for seating capacities with Cable Base Option and leg locations.

To Order, Specify:

1) Product number, including:

① Wood Edge Option:

- K** Edgeband
- U** Knife

② Flip Top Unit Cutout(s):

- N** None
- F** Center – single-sided/4 outlets, add **\$33.13** list
- V** Left/Right – single-sided/4 outlets, add **\$66.26** list
- J** Center – single-sided/6 outlets, add **\$33.13** list
- K** Left/Right – single-sided/6 outlets, add **\$66.26** list
- M** Center – double-sided/8 outlets, add **\$33.13** list
- P** Left/Right – double-sided/8 outlets, add **\$66.26** list
- Q** Center – double-sided/12 outlets, add **\$33.13** list
- T** Left/Right – double-sided/12 outlets, add **\$66.26** list

③ Cable Base Option:

- N** None
- C** Cable Base: add **\$662.73** list for 36" deep tables; add **\$698.87** list for 42" deep and deeper tables

2) Wood finish color.

3) Base trim color.

4) Wood finish color – Cable Base

Note: **\$45.78** upcharge (list) for Metallic and accent trim colors.

Planes Conference Tables — One-Piece Top — Interior Leg — Wood

Rectangular

No. of Legs	Seating Capacity*	Depth	Width	Number	①	②	③	Wood Group A		Wood Group B	
								K	U	K	U
6	6	36"(914mm)	72"(1829mm)	TARA-3672-W	S	JG4		\$1621.38	\$2008.93	\$1776.72	\$2215.49
6	6		78"(1981mm)	TARA-3678-W	S	JG4		1740.75	2163.11	1917.90	2396.87
6	6		84"(2134mm)	TARA-3684-W	S	JG4		1860.39	2319.20	2059.42	2580.51
6	8		90"(2286mm)	TARA-3690-W	S	JG4		1980.31	2477.22	2201.28	2766.39
6	8		96"(2438mm)	TARA-3696-W	S	JG4		2100.50	2637.15	2343.47	2954.51
6	6	42"(1067mm)	84"(2134mm)	TARA-4284-W	S	JG4		\$2120.60	\$2600.28	\$2366.54	\$2911.60
6	8		90"(2286mm)	TARA-4290-W	S	JG4		2258.56	2777.15	2529.67	3119.70
6	8		96"(2438mm)	TARA-4296-W	S	JG4		2396.79	2955.95	2693.13	3330.05
6	8		102"(2591mm)	TARA-42A2-W	S	JG4		2535.30	3136.66	2856.93	3542.65
6	10		108"(2743mm)	TARA-42A8-W	S	JG4		2674.09	3319.29	3021.07	3757.49
6	10		114"(2896mm)	TARA-42B4-W	S	JG4		2813.15	3503.84	3185.54	3974.58
6	10		120"(3048mm)	TARA-42C0-W	S	JG4		2952.49	3690.30	3350.35	4193.91
6	6	48"(1291mm)	84"(2134mm)	TARA-4884-W	S	JG4		\$2380.82	\$2881.36	\$2673.66	\$3242.69
6	8		90"(2286mm)	TARA-4890-W	S	JG4		2536.81	3077.09	2858.06	3473.02
6	8		96"(2438mm)	TARA-4896-W	S	JG4		2693.08	3274.74	3042.79	3705.59
6	8		102"(2591mm)	TARA-48A2-W	S	JG4		2849.63	3474.31	3227.85	3940.41
6	10		108"(2743mm)	TARA-48A8-W	S	JG4		3006.46	3675.80	3413.26	4177.48
6	10		114"(2896mm)	TARA-48B4-W	S	JG4		3163.56	3879.21	3599.00	4416.79
6	10		120"(3048mm)	TARA-48C0-W	S	JG4		3320.93	4084.53	3785.08	4658.35
6	8	54"(1372mm)	84"(2134mm)	TARA-5484-W	S	JG4		\$2939.97	\$3461.37	\$3279.72	\$3872.72
6	10		90"(2286mm)	TARA-5490-W	S	JG4		3114.01	3675.96	3485.38	4125.27
6	10		96"(2438mm)	TARA-5496-W	S	JG4		3288.32	3892.48	3691.38	4380.07
6	10		102"(2591mm)	TARA-54A2-W	S	JG4		3462.90	4110.91	3897.72	4637.11
6	10		108"(2743mm)	TARA-54A8-W	S	JG4		3637.76	4331.25	4104.39	4896.40
6	10		114"(2896mm)	TARA-54B4-W	S	JG4		3812.90	4553.52	4311.40	5157.94
6	10		120"(3048mm)	TARA-54C0-W	S	JG4		3988.32	4777.70	4518.75	5421.72
6	10	60"(1524mm)	84"(2134mm)	TARA-6084-W	S	JG4		\$3229.82	\$3772.08	\$3616.47	\$4233.45
6	10		90"(2286mm)	TARA-6090-W	S	JG4		3421.89	4005.53	3843.40	4508.22
6	10		96"(2438mm)	TARA-6096-W	S	JG4		3614.24	4240.90	4070.67	4785.24
6	10		102"(2591mm)	TARA-60A2-W	S	JG4		3806.86	4478.19	4298.27	5064.50
6	10		108"(2743mm)	TARA-60A8-W	S	JG4		3999.76	4717.39	4526.21	5346.02
6	10		114"(2896mm)	TARA-60B4-W	S	JG4		4192.94	4958.52	4754.49	5629.78
6	10		120"(3048mm)	TARA-60C0-W	S	JG4		4386.39	5201.56	4983.11	5915.78

*Recommended seating capacity based upon 27"(686mm) per chair.

Planes Conference Tables — One-Piece Top — Interior Leg — Wood

Pebble

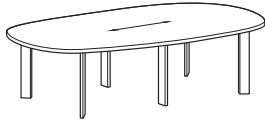

TARP

Features

- Includes 1 3/16" (30mm) thick top, interior leg bases and hardware.
- Standard table height is 29" (737mm).
- Wood veneer top with 3mm wood edgeband or knife wood edge.
- Interior legs are painted aluminum.
- Interior leg is 1 1/8" (29mm) x 3 1/4" (83mm).
- Optional cable base can be specified for tables 36" (914mm) deep and deeper:
 - 36" (914mm) deep tables will ship with 8" (203mm) x 14" (356mm) cable base.
 - 42" (1067mm) deep and deeper tables will ship with 14" (356mm) x 14" (356mm) cable base.
 - One piece tops will include one cable base to be centered under table top.
 - Cable base and table top(s) are wood veneer and can be specified in different surface colors and edge trim colors.
 - Refer to Specification Guide for use guidelines.
- Optional Flip top unit electrical modules are separately specified. Refer to electrical components for appropriate product specification.
- Available with glides only; 1/2" (13mm) height adjustment.
- Depth and width shown in nominal dimensions.
- Ships unassembled.

Specification Tips

- Cable base for 36" (914mm) deep table is not compatible with Flip Top Cut Out Options (M) and (Q).
- The following Planes products are separately specified:
 - Grommets (field cut opening)
 - Flip top unit electrical modules
 - Horizontal wire management
- Refer to Specification Guide for seating capacities with Cable Base Option and leg locations.

To Order, Specify:

1) Product number, including:

① Wood Edge Option:

- K** Edgeband
- U** Knife

② Flip Top Unit Cutout(s):

- N** None
- F** Center – single-sided/4 outlets, add **\$33.13** list
- V** Left/Right – single-sided/4 outlets, add **\$66.26** list
- J** Center – single-sided/6 outlets, add **\$33.13** list
- K** Left/Right – single-sided/6 outlets, add **\$66.26** list
- M** Center – double-sided/8 outlets, add **\$33.13** list
- P** Left/Right – double-sided/8 outlets, add **\$66.26** list
- Q** Center – double-sided/12 outlets, add **\$33.13** list
- T** Left/Right – double-sided/12 outlets, add **\$66.26** list

③ Cable Base Option:

- N** None
- C** Cable Base: add **\$662.73** list for 36" deep tables; add **\$698.87** list for 42" deep and deeper tables

2) Wood finish color.

3) Base trim color.

4) Wood finish color – Cable Base

Note: **\$45.78** upcharge (list) for Metallic and accent trim colors.

Planes Conference Tables — One-Piece Top — Interior Leg — Wood

Pebble

No. of Legs	Seating Capacity*	Depth	Width	Number	①	②	③	Wood Group A		Wood Group B	
								K	U	K	U
4	6	36"(914mm)	72"(1829mm)	TARP-3672-W	S	JG4		\$1621.38	\$2008.93	\$1776.72	\$2215.49
6	6		78"(1981mm)	TARP-3678-W	S	JG4		1740.75	2163.11	1917.90	2396.87
6	6		84"(2134mm)	TARP-3684-W	S	JG4		1860.39	2319.20	2059.42	2580.51
6	8		90"(2286mm)	TARP-3690-W	S	JG4		1980.31	2477.22	2201.28	2766.39
6	8		96"(2438mm)	TARP-3696-W	S	JG4		2100.50	2637.15	2343.47	2954.51
6	6	42"(1067mm)	84"(2134mm)	TARP-4284-W	S	JG4		\$2120.60	\$2600.28	\$2366.54	\$2911.60
6	8		90"(2286mm)	TARP-4290-W	S	JG4		2258.56	2777.15	2529.67	3119.70
6	8		96"(2438mm)	TARP-4296-W	S	JG4		2396.79	2955.95	2693.13	3330.05
6	8		102"(2591mm)	TARP-42A2-W	S	JG4		2535.30	3136.66	2856.93	3542.65
6	10		108"(2743mm)	TARP-42A8-W	S	JG4		2674.09	3319.29	3021.07	3757.49
6	10		114"(2896mm)	TARP-42B4-W	S	JG4		2813.15	3503.84	3185.54	3974.58
6	10		120"(3048mm)	TARP-42C0-W	S	JG4		2952.49	3690.30	3350.35	4193.91
6	6	48"(1291mm)	84"(2134mm)	TARP-4884-W	S	JG4		\$2380.82	\$2881.36	\$2673.66	\$3242.69
6	8		90"(2286mm)	TARP-4890-W	S	JG4		2536.81	3077.09	2858.06	3473.02
6	8		96"(2438mm)	TARP-4896-W	S	JG4		2693.08	3274.74	3042.79	3705.59
6	8		102"(2591mm)	TARP-48A2-W	S	JG4		2849.63	3474.31	3227.85	3940.41
6	10		108"(2743mm)	TARP-48A8-W	S	JG4		3006.46	3675.80	3413.26	4177.48
6	10		114"(2896mm)	TARP-48B4-W	S	JG4		3163.56	3879.21	3599.00	4416.79
6	10		120"(3048mm)	TARP-48C0-W	S	JG4		3320.93	4084.53	3785.08	4658.35
6	8	54"(1372mm)	84"(2134mm)	TARP-5484-W	S	JG4		\$2939.97	\$3461.37	\$3279.72	\$3872.72
6	10		90"(2286mm)	TARP-5490-W	S	JG4		3114.01	3675.96	3485.38	4125.27
6	10		96"(2438mm)	TARP-5496-W	S	JG4		3288.32	3892.48	3691.38	4380.07
6	10		102"(2591mm)	TARP-54A2-W	S	JG4		3462.90	4110.91	3897.72	4637.11
6	10		108"(2743mm)	TARP-54A8-W	S	JG4		3637.76	4331.25	4104.39	4896.40
6	10		114"(2896mm)	TARP-54B4-W	S	JG4		3812.90	4553.52	4311.40	5157.94
6	10		120"(3048mm)	TARP-54C0-W	S	JG4		3988.32	4777.70	4518.75	5421.72
6	10	60"(1524mm)	84"(2134mm)	TARP-6084-W	S	JG4		\$3229.82	\$3772.08	\$3616.47	\$4233.45
6	10		90"(2286mm)	TARP-6090-W	S	JG4		3421.89	4005.53	3843.40	4508.22
6	10		96"(2438mm)	TARP-6096-W	S	JG4		3614.24	4240.90	4070.67	4785.24
6	10		102"(2591mm)	TARP-60A2-W	S	JG4		3806.86	4478.19	4298.27	5064.50
6	10		108"(2743mm)	TARP-60A8-W	S	JG4		3999.76	4717.39	4526.21	5346.02
6	10		114"(2896mm)	TARP-60B4-W	S	JG4		4192.94	4958.52	4754.49	5629.78
6	10		120"(3048mm)	TARP-60C0-W	S	JG4		4386.39	5201.56	4983.11	5915.78

*Recommended seating capacity based upon 27"(686mm) per chair.

Planes Conference Tables — One-Piece Top — Interior Leg — Wood

Hexagon

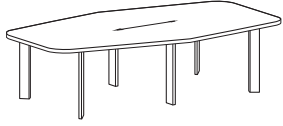

TARX

Features

- Includes 1 3/16" (30mm) thick top, interior leg bases and hardware.
- Standard table height is 29" (737mm).
- Wood veneer top with 3mm wood edgeband or knife wood edge.
- Interior legs are painted aluminum.
- Interior leg is 1 1/8" (29mm) x 3 1/4" (83mm).
- Optional cable base can be specified for tables 36" (914mm) deep and deeper:
 - 36" (914mm) deep tables will ship with 8" (203mm) x 14" (356mm) cable base.
 - 42" (1067mm) deep and deeper tables will ship with 14" (356mm) x 14" (356mm) cable base.
 - One piece tops will include one cable base to be centered under table top.
 - Cable base and table top(s) are wood veneer and can be specified in different surface colors and edge trim colors.
 - Refer to Specification Guide for use guidelines.
- Optional Flip top unit electrical modules are separately specified. Refer to electrical components for appropriate product specification.
- Available with glides only; 1/2" (13mm) height adjustment.
- Depth and width shown in nominal dimensions.
- Ships unassembled.

Specification Tips

- Cable base for 36" (914mm) deep table is not compatible with Flip Top Cut Out Options (M) and (Q).
- The following Planes products are separately specified:
 - Grommets (field cut opening)
 - Flip top unit electrical modules
 - Horizontal wire management
- Refer to Specification Guide for seating capacities with Cable Base Option and leg locations.

To Order, Specify:

1) Product number, including:

① Wood Edge Option:

- K** Edgeband
- U** Knife

② Flip Top Unit Cutout(s):

- N** None
- F** Center – single-sided/4 outlets, add **\$33.13** list
- V** Left/Right – single-sided/4 outlets, add **\$66.26** list
- J** Center – single-sided/6 outlets, add **\$33.13** list
- K** Left/Right – single-sided/6 outlets, add **\$66.26** list
- M** Center – double-sided/8 outlets, add **\$33.13** list
- P** Left/Right – double-sided/8 outlets, add **\$66.26** list
- Q** Center – double-sided/12 outlets, add **\$33.13** list
- T** Left/Right – double-sided/12 outlets, add **\$66.26** list

③ Cable Base Option:

- N** None
- C** Cable Base: add **\$662.73** list for 36" deep tables; add **\$698.87** list for 42" deep and deeper tables

2) Wood finish color.

3) Base trim color.

4) Wood finish color – Cable Base

Note: **\$45.78** upcharge (list) for Metallic and accent trim colors.

Planes Conference Tables — One-Piece Top — Interior Leg — Wood

Hexagon

No. of Legs	Seating Capacity*	Depth	Width	Number	①	②	③	Wood Group A		Wood Group B	
								K	U	K	U
4	6	36"(914mm)	72"(1829mm)	TARX-3672-W	S	JG4		\$1621.38	\$2008.93	\$1776.72	\$2215.49
6	6		78"(1981mm)	TARX-3678-W	S	JG4		1740.75	2163.11	1917.90	2396.87
6	6		84"(2134mm)	TARX-3684-W	S	JG4		1860.39	2319.20	2059.42	2580.51
6	8		90"(2286mm)	TARX-3690-W	S	JG4		1980.31	2477.22	2201.28	2766.39
6	8		96"(2438mm)	TARX-3696-W	S	JG4		2100.50	2637.15	2343.47	2954.51
6	6	42"(1067mm)	84"(2134mm)	TARX-4284-W	S	JG4		\$2120.60	\$2600.28	\$2366.54	\$2911.60
6	8		90"(2286mm)	TARX-4290-W	S	JG4		2258.56	2777.15	2529.67	3119.70
6	8		96"(2438mm)	TARX-4296-W	S	JG4		2396.79	2955.95	2693.13	3330.05
6	8		102"(2591mm)	TARX-42A2-W	S	JG4		2535.30	3136.66	2856.93	3542.65
6	10		108"(2743mm)	TARX-42A8-W	S	JG4		2674.09	3319.29	3021.07	3757.49
6	10		114"(2896mm)	TARX-42B4-W	S	JG4		2813.15	3503.84	3185.54	3974.58
6	10		120"(3048mm)	TARX-42C0-W	S	JG4		2952.49	3690.30	3350.35	4193.91
6	6	48"(1291mm)	84"(2134mm)	TARX-4884-W	S	JG4		\$2380.82	\$2881.36	\$2673.66	\$3242.69
6	8		90"(2286mm)	TARX-4890-W	S	JG4		2536.81	3077.09	2858.06	3473.02
6	8		96"(2438mm)	TARX-4896-W	S	JG4		2693.08	3274.74	3042.79	3705.59
6	8		102"(2591mm)	TARX-48A2-W	S	JG4		2849.63	3474.31	3227.85	3940.41
6	10		108"(2743mm)	TARX-48A8-W	S	JG4		3006.46	3675.80	3413.26	4177.48
6	10		114"(2896mm)	TARX-48B4-W	S	JG4		3163.56	3879.21	3599.00	4416.79
6	10		120"(3048mm)	TARX-48C0-W	S	JG4		3320.93	4084.53	3785.08	4658.35
6	8	54"(1372mm)	84"(2134mm)	TARX-5484-W	S	JG4		\$2939.97	\$3461.37	\$3279.72	\$3872.72
6	10		90"(2286mm)	TARX-5490-W	S	JG4		3114.01	3675.96	3485.38	4125.27
6	10		96"(2438mm)	TARX-5496-W	S	JG4		3288.32	3892.48	3691.38	4380.07
6	10		102"(2591mm)	TARX-54A2-W	S	JG4		3462.90	4110.91	3897.72	4637.11
6	10		108"(2743mm)	TARX-54A8-W	S	JG4		3637.76	4331.25	4104.39	4896.40
6	10		114"(2896mm)	TARX-54B4-W	S	JG4		3812.90	4553.52	4311.40	5157.94
6	10		120"(3048mm)	TARX-54C0-W	S	JG4		3988.32	4777.70	4518.75	5421.72
6	10	60"(1524mm)	84"(2134mm)	TARX-6084-W	S	JG4		\$3229.82	\$3772.08	\$3616.47	\$4233.45
6	10		90"(2286mm)	TARX-6090-W	S	JG4		3421.89	4005.53	3843.40	4508.22
6	10		96"(2438mm)	TARX-6096-W	S	JG4		3614.24	4240.90	4070.67	4785.24
6	10		102"(2591mm)	TARX-60A2-W	S	JG4		3806.86	4478.19	4298.27	5064.50
6	10		108"(2743mm)	TARX-60A8-W	S	JG4		3999.76	4717.39	4526.21	5346.02
6	10		114"(2896mm)	TARX-60B4-W	S	JG4		4192.94	4958.52	4754.49	5629.78
6	10		120"(3048mm)	TARX-60C0-W	S	JG4		4386.39	5201.56	4983.11	5915.78

*Recommended seating capacity based upon 27"(686mm) per chair.

Planes Conference Tables — Two-Piece Tops — Interior Leg — Laminate

Rectangular

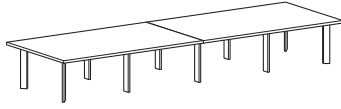

TARA

Features

- Includes 1 3/16" (30mm) thick tops, interior leg bases and hardware.
- Standard table height is 29" (737mm).
- Laminate top with 3mm edgeband or knife edges.
- Table top seam is 1mm edgeband.
- Interior legs are painted aluminum.
- Interior leg is 1 1/8" (29mm) x 3 1/4" (83mm).
- Optional cable base is available:
 - 42" (1067mm) deep and deeper tables will ship with 14" (356mm) x 14" (356mm) cable base
 - Two piece tops will include one cable base to be centered on seam under table top.
 - Cable base and table top(s) are laminate and can be specified in different surface colors and edge trim colors.
 - Refer to Specification Guide for use guidelines.
- Optional Flip top unit electrical modules are separately specified. Refer to electrical components for appropriate product specification.
- Available with glides only; 1/2" (13mm) height adjustment.
- Depth and width shown in nominal dimensions.
- Ships unassembled.

Specification Tips

- Tables with multiple-piece tops have equal sized pieces.
- The following Planes products are separately specified:
 - Grommets (field cut opening)
 - Flip top unit electrical modules
 - Horizontal wire management
- Refer to Specification Guide for seating capacities with Cable Base Option and leg locations.

To Order, Specify:

1) Product number, including:

① Edge Option:

- J** Edgeband
- F** Knife

② Flip Top Unit Cutout(s):

- N** None
- F** Center – single-sided/4 outlets, add **\$66.26** list
- V** Left/Right – single-sided/4 outlets, add **\$132.52** list
- J** Center – single-sided/6 outlets, add **\$66.26** list
- K** Left/Right – single-sided/6 outlets, add **\$132.52** list
- M** Center – double-sided/8 outlets, add **\$66.26** list
- P** Left/Right – double-sided/8 outlets, add **\$132.52** list
- Q** Center – double-sided/12 outlets, add **\$66.26** list
- T** Left/Right – double-sided/12 outlets, add **\$132.52** list

③ Cable Base Option:

- N** None
- C** Cable Base, add **\$698.87** list

- 2) Laminate surface color.
- 3) 1mm edgeband trim color. (Cascade edge/multiple-tops only)*
- 4) Edge trim color.
- 5) Base trim color.
- 6) Laminate surface – Cable Base
- 7) Edge trim color – Cable Base

Note: **\$45.78** upcharge (list) for Metallic and accent trim colors.

Planes Conference Tables — Two-Piece Tops — Interior Leg — Laminate

Rectangular

No. of Legs	Seating Capacity*	Depth	Width	Number	①	②	③	Laminate A		Laminate B	
								J	F	J	F
6	10	42"(1067mm)	126"(3200mm)	TARA-42C6-L	S	JG4		\$2575.48	\$3053.27	\$2779.48	\$3257.27
6	10		132"(3353mm)	TARA-42D2-L	S	JG4		2687.10	3179.53	2900.83	3393.26
10	10		138"(3505mm)	TARA-42D8-L	S	JG4		2798.72	3305.79	3022.18	3529.25
10	10		144"(3658mm)	TARA-42E4-L	S	JG4		2910.34	3432.05	3143.53	3665.24
10	10		150"(3810mm)	TARA-42F0-L	S	JG4		3021.96	3558.31	3264.88	3801.23
10	12		156"(3962mm)	TARA-42F6-L	S	JG4		3133.58	3684.57	3386.23	3937.22
10	12		162"(4115mm)	TARA-42G2-L	S	JG4		3245.20	3810.83	3507.58	4073.21
10	12		168"(4267mm)	TARA-42G8-L	S	JG4		3356.82	3937.09	3628.93	4209.20
10	12		174"(4420mm)	TARA-42H4-L	S	JG4		3468.44	4063.35	3750.28	4345.19
10	12		180"(4572mm)	TARA-42J0-L	S	JG4		3580.06	4189.61	3871.63	4481.18
6	10	48"(1219mm)	126"(3200mm)	TARA-48C6-L	S	JG4		\$2910.00	\$3402.43	\$3143.19	\$3635.62
6	10		132"(3353mm)	TARA-48D2-L	S	JG4		3033.66	3540.73	3277.97	3785.04
10	10		138"(3505mm)	TARA-48D8-L	S	JG4		3157.32	3679.03	3412.75	3934.46
10	10		144"(3658mm)	TARA-48E4-L	S	JG4		3280.98	3817.33	3547.53	4083.88
10	10		150"(3810mm)	TARA-48F0-L	S	JG4		3404.64	3955.63	3682.31	4233.30
10	12		156"(3962mm)	TARA-48F6-L	S	JG4		3528.30	4093.93	3817.09	4382.72
10	12		162"(4115mm)	TARA-48G2-L	S	JG4		3651.96	4232.23	3951.87	4532.14
10	12		168"(4267mm)	TARA-48G8-L	S	JG4		3775.62	4370.53	4086.65	4681.56
10	12		174"(4420mm)	TARA-48H4-L	S	JG4		3899.28	4508.83	4221.43	4830.98
10	12		180"(4572mm)	TARA-48J0-L	S	JG4		4022.94	4647.13	4356.21	4980.40
6	10	54"(1372mm)	126"(3200mm)	TARA-54C6-L	S	JG4		\$3244.52	\$3751.59	\$3506.90	\$4013.97
6	10		132"(3353mm)	TARA-54D2-L	S	JG4		3380.22	3901.93	3655.11	4176.82
10	10		138"(3505mm)	TARA-54D8-L	S	JG4		3515.92	4052.27	3803.32	4339.67
10	10		144"(3658mm)	TARA-54E4-L	S	JG4		3651.62	4202.61	3951.53	4502.52
10	10		150"(3810mm)	TARA-54F0-L	S	JG4		3787.32	4352.95	4099.74	4665.37
10	12		156"(3962mm)	TARA-54F6-L	S	JG4		3923.02	4503.29	4247.95	4828.22
10	12		162"(4115mm)	TARA-54G2-L	S	JG4		4058.72	4653.63	4396.16	4991.07
10	12		168"(4267mm)	TARA-54G8-L	S	JG4		4194.42	4803.97	4544.37	5153.92
10	14		174"(4420mm)	TARA-54H4-L	S	JG4		4330.12	4954.31	4692.58	5316.77
10	14		180"(4572mm)	TARA-54J0-L	S	JG4		4465.82	5104.65	4840.79	5479.62
6	10	60"(1524mm)	126"(3200mm)	TARA-60C6-L	S	JG4		\$3579.04	\$4100.75	\$3870.61	\$4392.32
6	10		132"(3353mm)	TARA-60D2-L	S	JG4		3726.78	4263.13	4032.25	4568.60
10	10		138"(3505mm)	TARA-60D8-L	S	JG4		3874.52	4425.51	4193.89	4744.88
10	10		144"(3658mm)	TARA-60E4-L	S	JG4		4022.26	4587.89	4355.53	4921.16
10	10		150"(3810mm)	TARA-60F0-L	S	JG4		4170.00	4750.27	4517.17	5097.44
10	12		156"(3962mm)	TARA-60F6-L	S	JG4		4317.74	4912.65	4678.81	5273.72
10	12		162"(4115mm)	TARA-60G2-L	S	JG4		4465.48	5075.03	4840.45	5450.00
10	12		168"(4267mm)	TARA-60G8-L	S	JG4		4613.22	5237.41	5002.09	5626.28
10	14		174"(4420mm)	TARA-60H4-L	S	JG4		4760.96	5399.79	5163.73	5802.56
10	14		180"(4572mm)	TARA-60J0-L	S	JG4		4908.70	5562.17	5325.37	5978.84

*Recommended seating capacity based upon 27"(686mm) per chair.

Planes Conference Tables — Two-Piece Tops — Interior Leg — Laminate

Pebble

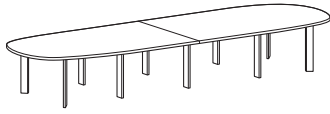

TARP

Features

- Includes 1 3/16" (30mm) thick tops, interior leg bases and hardware.
- Standard table height is 29" (737mm).
- Laminate top with 3mm edgeband or knife edges.
- Table top seam is 1mm edgeband.
- Interior legs are painted aluminum.
- Interior leg is 1 1/8" (29mm) x 3 1/4" (83mm).
- Optional cable base is available:
 - 42" (1067mm) deep and deeper tables will ship with 14" (356mm) x 14" (356mm) cable base
 - Two piece tops will include one cable base to be centered on seam under table top.
 - Cable base and table top(s) are laminate and can be specified in different surface colors and edge trim colors.
 - Refer to Specification Guide for use guidelines.
- Optional Flip top unit electrical modules are separately specified. Refer to electrical components for appropriate product specification.
- Available with glides only; 1/2" (13mm) height adjustment.
- Depth and width shown in nominal dimensions.
- Ships unassembled.

Specification Tips

- Tables with multiple-piece tops have equal sized pieces.
- The following Planes products are separately specified:
 - Grommets (field cut openings)
 - Flip top unit electrical modules
 - Horizontal wire management
- Refer to Specification Guide for seating capacities with Cable Base Option and leg locations.

To Order, Specify:

1) Product number, including:

① Edge Option:

- J** Edgeband
- F** Knife

② Flip Top Unit Cutout(s):

- N** None
- F** Center – single-sided/4 outlets, add **\$66.26** list
- V** Left/Right – single-sided/4 outlets, add **\$132.52** list
- J** Center – single-sided/6 outlets, add **\$66.26** list
- K** Left/Right – single-sided/6 outlets, add **\$132.52** list
- M** Center – double-sided/8 outlets, add **\$66.26** list
- P** Left/Right – double-sided/8 outlets, add **\$132.52** list
- Q** Center – double-sided/12 outlets, add **\$66.26** list
- T** Left/Right – double-sided/12 outlets, add **\$132.52** list

③ Cable Base Option:

- N** None
- C** Cable Base, add **\$698.87** list

- 2) Laminate surface color.
- 3) 1mm edgeband trim color. (Cascade edge/multiple-tops only)*
- 4) Edge trim color.
- 5) Base trim color.
- 6) Laminate surface – Cable Base
- 7) Edge trim color – Cable Base

Note: **\$45.78** upcharge (list) for Metallic and accent trim colors.

Planes Conference Tables — Two-Piece Tops — Interior Leg — Laminate

Pebble

No. of Legs	Seating Capacity*	Depth	Width	Number	①	②	③	Laminate A		Laminate B	
								J	F	J	F
6	10	42"(1067mm)	126"(3200mm)	TARP-42C6-L	S	JG4		\$2575.48	\$3053.27	\$2779.48	\$3257.27
6	10		132"(3353mm)	TARP-42D2-L	S	JG4		2687.10	3179.53	2900.83	3393.26
6	10		138"(3505mm)	TARP-42D8-L	S	JG4		2798.72	3305.79	3022.18	3529.25
6	10		144"(3658mm)	TARP-42E4-L	S	JG4		2910.34	3432.05	3143.53	3665.24
10	10		150"(3810mm)	TARP-42F0-L	S	JG4		3021.96	3558.31	3264.88	3801.23
10	10		156"(3962mm)	TARP-42F6-L	S	JG4		3133.58	3684.57	3386.23	3937.22
10	10		162"(4115mm)	TARP-42G2-L	S	JG4		3245.20	3810.83	3507.58	4073.21
10	12		168"(4267mm)	TARP-42G8-L	S	JG4		3356.82	3937.09	3628.93	4209.20
10	12		174"(4420mm)	TARP-42H4-L	S	JG4		3468.44	4063.35	3750.28	4345.19
10	12		180"(4572mm)	TARP-42J0-L	S	JG4		3580.06	4189.61	3871.63	4481.18
6	10	48"(1219mm)	126"(3200mm)	TARP-48C6-L	S	JG4		\$2910.00	\$3402.43	\$3143.19	\$3635.62
6	10		132"(3353mm)	TARP-48D2-L	S	JG4		3033.66	3540.73	3277.97	3785.04
6	10		138"(3505mm)	TARP-48D8-L	S	JG4		3157.32	3679.03	3412.75	3934.46
6	10		144"(3658mm)	TARP-48E4-L	S	JG4		3280.98	3817.33	3547.53	4083.88
10	10		150"(3810mm)	TARP-48F0-L	S	JG4		3404.64	3955.63	3682.31	4233.30
10	10		156"(3962mm)	TARP-48F6-L	S	JG4		3528.30	4093.93	3817.09	4382.72
10	10		162"(4115mm)	TARP-48G2-L	S	JG4		3651.96	4232.23	3951.87	4532.14
10	10		168"(4267mm)	TARP-48G8-L	S	JG4		3775.62	4370.53	4086.65	4681.56
10	12		174"(4420mm)	TARP-48H4-L	S	JG4		3899.28	4508.83	4221.43	4830.98
10	12		180"(4572mm)	TARP-48J0-L	S	JG4		4022.94	4647.13	4356.21	4980.40
6	10	54"(1372mm)	126"(3200mm)	TARP-54C6-L	S	JG4		\$3244.52	\$3751.59	\$3506.90	\$4013.97
6	10		132"(3353mm)	TARP-54D2-L	S	JG4		3380.22	3901.93	3655.11	4176.82
6	10		138"(3505mm)	TARP-54D8-L	S	JG4		3515.92	4052.27	3803.32	4339.67
6	10		144"(3658mm)	TARP-54E4-L	S	JG4		3651.62	4202.61	3951.53	4502.52
10	10		150"(3810mm)	TARP-54F0-L	S	JG4		3787.32	4352.95	4099.74	4665.37
10	10		156"(3962mm)	TARP-54F6-L	S	JG4		3923.02	4503.29	4247.95	4828.22
10	10		162"(4115mm)	TARP-54G2-L	S	JG4		4058.72	4653.63	4396.16	4991.07
10	10		168"(4267mm)	TARP-54G8-L	S	JG4		4194.42	4803.97	4544.37	5153.92
10	12		174"(4420mm)	TARP-54H4-L	S	JG4		4330.12	4954.31	4692.58	5316.77
10	12		180"(4572mm)	TARP-54J0-L	S	JG4		4465.82	5104.65	4840.79	5479.62
6	10	60"(1524mm)	126"(3200mm)	TARP-60C6-L	S	JG4		\$3579.04	\$4100.75	\$3870.61	\$4392.32
6	10		132"(3353mm)	TARP-60D2-L	S	JG4		3726.78	4263.13	4032.25	4568.60
6	10		138"(3505mm)	TARP-60D8-L	S	JG4		3874.52	4425.51	4193.89	4744.88
6	10		144"(3658mm)	TARP-60E4-L	S	JG4		4022.26	4587.89	4355.53	4921.16
10	10		150"(3810mm)	TARP-60F0-L	S	JG4		4170.00	4750.27	4517.17	5097.44
10	10		156"(3962mm)	TARP-60F6-L	S	JG4		4317.74	4912.65	4678.81	5273.72
10	10		162"(4115mm)	TARP-60G2-L	S	JG4		4465.48	5075.03	4840.45	5450.00
10	10		168"(4267mm)	TARP-60G8-L	S	JG4		4613.22	5237.41	5002.09	5626.28
10	12		174"(4420mm)	TARP-60H4-L	S	JG4		4760.96	5399.79	5163.73	5802.56
10	12		180"(4572mm)	TARP-60J0-L	S	JG4		4908.70	5562.17	5325.37	5978.84

*Recommended seating capacity based upon 27"(686mm) per chair.

Planes Conference Tables — Two-Piece Tops — Interior Leg — Laminate

Hexagon

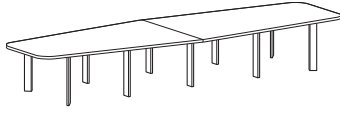

TARX

Features

- Includes 1 3/16" (30mm) thick tops, interior leg bases and hardware.
- Standard table height is 29" (737mm).
- Laminate top with 3mm edgeband or knife edges.
- Table top seam is 1mm edgeband.
- Interior legs are painted aluminum.
- Interior leg is 1 1/8" (29mm) x 3 1/4" (83mm).
- Optional cable base is available:
 - 42" (1067mm) deep and deeper tables will ship with 14" (356mm) x 14" (356mm) cable base
 - Two piece tops will include one cable base to be centered on seam under table top.
 - Cable base and table top(s) are laminate and can be specified in different surface colors and edge trim colors.
 - Refer to Specification Guide for use guidelines.
- Optional Flip top unit electrical modules are separately specified. Refer to electrical components for appropriate product specification.
- Available with glides only; 1/2" (13mm) height adjustment.
- Depth and width shown in nominal dimensions.
- Ships unassembled.

Specification Tips

- Tables with multiple-piece tops have equal sized pieces.
- The following Planes products are separately specified:
 - Grommets (field cut openings)
 - Flip top unit electrical modules
 - Horizontal wire management
- Refer to Specification Guide for seating capacities with Cable Base Option and leg locations.

To Order, Specify:

1) Product number, including:

① Edge Option:

- J** Edgeband
- F** Knife

② Flip Top Unit Cutout(s):

- N** None
- F** Center – single-sided/4 outlets, add **\$66.26** list
- V** Left/Right – single-sided/4 outlets, add **\$132.52** list
- J** Center – single-sided/6 outlets, add **\$66.26** list
- K** Left/Right – single-sided/6 outlets, add **\$132.52** list
- M** Center – double-sided/8 outlets, add **\$66.26** list
- P** Left/Right – double-sided/8 outlets, add **\$132.52** list
- Q** Center – double-sided/12 outlets, add **\$66.26** list
- T** Left/Right – double-sided/12 outlets, add **\$132.52** list

③ Cable Base Option:

- N** None
- C** Cable Base, add **\$698.87** list

- 2) Laminate surface color.
- 3) 1mm edgeband trim color. (Cascade edge/multiple-tops only)*
- 4) Edge trim color.
- 5) Base trim color.
- 6) Laminate surface – Cable Base
- 7) Edge trim color – Cable Base

Note: **\$45.78** upcharge (list) for Metallic and accent trim colors.

Planes Conference Tables — Two-Piece Tops — Interior Leg — Laminate

Hexagon

No. of Legs	Seating Capacity*	Depth	Width	Number	①	②	③	Laminate A		Laminate B	
								J	F	J	F
6	10	42"(1067mm)	126"(3200mm)	TARX-42C6-L	S	JG4		\$2575.48	\$3053.27	\$2779.48	\$3257.27
6	10		132"(3353mm)	TARX-42D2-L	S	JG4		2687.10	3179.53	2900.83	3393.26
6	10		138"(3505mm)	TARX-42D8-L	S	JG4		2798.72	3305.79	3022.18	3529.25
6	10		144"(3658mm)	TARX-42E4-L	S	JG4		2910.34	3432.05	3143.53	3665.24
10	10		150"(3810mm)	TARX-42F0-L	S	JG4		3021.96	3558.31	3264.88	3801.23
10	10		156"(3962mm)	TARX-42F6-L	S	JG4		3133.58	3684.57	3386.23	3937.22
10	10		162"(4115mm)	TARX-42G2-L	S	JG4		3245.20	3810.83	3507.58	4073.21
10	10		168"(4267mm)	TARX-42G8-L	S	JG4		3356.82	3937.09	3628.93	4209.20
10	12		174"(4420mm)	TARX-42H4-L	S	JG4		3468.44	4063.35	3750.28	4345.19
10	12		180"(4572mm)	TARX-42J0-L	S	JG4		3580.06	4189.61	3871.63	4481.18
6	10	48"(1219mm)	126"(3200mm)	TARX-48C6-L	S	JG4		\$2910.00	\$3402.43	\$3143.19	\$3635.62
6	10		132"(3353mm)	TARX-48D2-L	S	JG4		3033.66	3540.73	3277.97	3785.04
6	10		138"(3505mm)	TARX-48D8-L	S	JG4		3157.32	3679.03	3412.75	3934.46
6	10		144"(3658mm)	TARX-48E4-L	S	JG4		3280.98	3817.33	3547.53	4083.88
10	10		150"(3810mm)	TARX-48F0-L	S	JG4		3404.64	3955.63	3682.31	4233.30
10	10		156"(3962mm)	TARX-48F6-L	S	JG4		3528.30	4093.93	3817.09	4382.72
10	10		162"(4115mm)	TARX-48G2-L	S	JG4		3651.96	4232.23	3951.87	4532.14
10	10		168"(4267mm)	TARX-48G8-L	S	JG4		3775.62	4370.53	4086.65	4681.56
10	12		174"(4420mm)	TARX-48H4-L	S	JG4		3899.28	4508.83	4221.43	4830.98
10	12		180"(4572mm)	TARX-48J0-L	S	JG4		4022.94	4647.13	4356.21	4980.40
6	10	54"(1372mm)	126"(3200mm)	TARX-54C6-L	S	JG4		\$3244.52	\$3751.59	\$3506.90	\$4013.97
6	10		132"(3353mm)	TARX-54D2-L	S	JG4		3380.22	3901.93	3655.11	4176.82
6	10		138"(3505mm)	TARX-54D8-L	S	JG4		3515.92	4052.27	3803.32	4339.67
6	10		144"(3658mm)	TARX-54E4-L	S	JG4		3651.62	4202.61	3951.53	4502.52
10	10		150"(3810mm)	TARX-54F0-L	S	JG4		3787.32	4352.95	4099.74	4665.37
10	10		156"(3962mm)	TARX-54F6-L	S	JG4		3923.02	4503.29	4247.95	4828.22
10	10		162"(4115mm)	TARX-54G2-L	S	JG4		4058.72	4653.63	4396.16	4991.07
10	10		168"(4267mm)	TARX-54G8-L	S	JG4		4194.42	4803.97	4544.37	5153.92
10	12		174"(4420mm)	TARX-54H4-L	S	JG4		4330.12	4954.31	4692.58	5316.77
10	12		180"(4572mm)	TARX-54J0-L	S	JG4		4465.82	5104.65	4840.79	5479.62
6	10	60"(1524mm)	126"(3200mm)	TARX-60C6-L	S	JG4		\$3579.04	\$4100.75	\$3870.61	\$4392.32
6	10		132"(3353mm)	TARX-60D2-L	S	JG4		3726.78	4263.13	4032.25	4568.60
6	10		138"(3505mm)	TARX-60D8-L	S	JG4		3874.52	4425.51	4193.89	4744.88
6	10		144"(3658mm)	TARX-60E4-L	S	JG4		4022.26	4587.89	4355.53	4921.16
10	10		150"(3810mm)	TARX-60F0-L	S	JG4		4170.00	4750.27	4517.17	5097.44
10	10		156"(3962mm)	TARX-60F6-L	S	JG4		4317.74	4912.65	4678.81	5273.72
10	10		162"(4115mm)	TARX-60G2-L	S	JG4		4465.48	5075.03	4840.45	5450.00
10	10		168"(4267mm)	TARX-60G8-L	S	JG4		4613.22	5237.41	5002.09	5626.28
10	12		174"(4420mm)	TARX-60H4-L	S	JG4		4760.96	5399.79	5163.73	5802.56
10	12		180"(4572mm)	TARX-60J0-L	S	JG4		4908.70	5562.17	5325.37	5978.84

*Recommended seating capacity based upon 27"(686mm) per chair.

Planes Conference Tables — Two-Piece Tops — Interior Leg — Wood

Rectangular

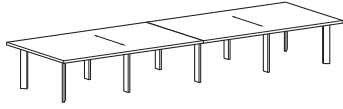

TARA

Features

- Includes 1 3/16" (30mm) thick tops, interior leg bases and hardware.
- Standard table height is 29" (737mm).
- Wood veneer top with 3mm wood edgeband or knife wood edge.
- Table top seam is 1mm edgeband.
- Interior legs are painted aluminum.
- Interior leg is 1 1/8" (29mm) x 3 1/4" (83mm).
- Optional cable base is available:
 - 42" (1067mm) deep and deeper tables will ship with 14" (356mm) x 14" (356mm) cable base
 - Two piece tops will include one cable base to be centered on seam under table top.
 - Cable base and table top(s) are wood veneer and can be specified in different surface colors and edge trim colors.
 - Refer to Specification Guide for use guidelines.
- Optional Flip top unit electrical modules are separately specified. Refer to electrical components for appropriate product specification.
- Available with glides only; 1/2" (13mm) height adjustment.
- Depth and width shown in nominal dimensions.
- Ships unassembled.

Specification Tips

- Tables with multiple-piece tops have equal sized pieces.
- The following Planes products are separately specified:
 - Grommets (field cut opening)
 - Flip top unit electrical modules
 - Horizontal wire management
- Refer to Specification Guide for seating capacities with Cable Base Option and leg locations.

To Order, Specify:

1) Product number, including:

① Wood Edge Option:

- K** Edgeband
- U** Knife

② Flip Top Unit Cutout(s):

- N** None
- F** Center – single-sided/4 outlets, add **\$66.26** list
- V** Left/Right – single-sided/4 outlets, add **\$132.52** list
- J** Center – single-sided/6 outlets, add **\$66.26** list
- K** Left/Right – single-sided/6 outlets, add **\$132.52** list
- M** Center – double-sided/8 outlets, add **\$66.26** list
- P** Left/Right – double-sided/8 outlets, add **\$132.52** list
- Q** Center – double-sided/12 outlets, add **\$66.26** list
- T** Left/Right – double-sided/12 outlets, add **\$132.52** list

③ Cable Base Option:

- N** None
- C** Cable Base, add **\$698.87** list

2) Wood finish color.

3) Base trim color.

4) Wood finish color – Cable Base

Note: **\$45.78** upcharge (list) for Metallic and accent trim colors.

Planes Conference Tables — Two-Piece Tops — Interior Leg — Wood

Rectangular

No. of Legs	Seating Capacity*	Depth	Width	Number	①	②	③	Wood Group A		Wood Group B	
								K	U	K	U
6	10	42"(1067mm)	126"(3200mm)	TARA-42C6-W	S	JG4		\$4115.14	\$ 5433.42	\$4538.53	\$ 5970.24
6	10		132"(3353mm)	TARA-42D2-W	S	JG4		4279.73	5643.49	4728.71	6213.82
10	10		138"(3505mm)	TARA-42D8-W	S	JG4		4444.60	5855.47	4919.23	6459.66
10	10		144"(3658mm)	TARA-42E4-W	S	JG4		4609.74	6069.36	5110.09	6707.74
10	10		150"(3810mm)	TARA-42F0-W	S	JG4		4775.16	6285.18	5301.28	6958.07
10	12		156"(3962mm)	TARA-42F6-W	S	JG4		4940.86	6502.91	5492.82	7210.64
10	12		162"(4115mm)	TARA-42G2-W	S	JG4		5106.83	6722.57	5684.68	7465.46
10	12		168"(4267mm)	TARA-42G8-W	S	JG4		5273.09	6944.14	5876.89	7722.53
10	12		174"(4420mm)	TARA-42H4-W	S	JG4		5439.61	7167.62	6069.43	7981.84
10	14		180"(4572mm)	TARA-42J0-W	S	JG4		5606.42	7393.03	6262.31	8243.40
6	10	48"(1219mm)	126"(3200mm)	TARA-48C6-W	S	JG4		\$4625.12	\$ 6105.87	\$5118.02	\$ 6716.25
6	10		132"(3353mm)	TARA-48D2-W	S	JG4		4807.75	6334.79	5329.48	6982.06
10	10		138"(3505mm)	TARA-48D8-W	S	JG4		4990.66	6565.63	5541.27	7250.12
10	10		144"(3658mm)	TARA-48E4-W	S	JG4		5173.84	6798.39	5753.39	7520.42
10	10		150"(3810mm)	TARA-48F0-W	S	JG4		5357.30	7033.06	5965.86	7792.97
10	12		156"(3962mm)	TARA-48F6-W	S	JG4		5541.03	7269.66	6178.66	8067.77
10	12		162"(4115mm)	TARA-48G2-W	S	JG4		5725.05	7508.17	6391.79	8344.81
10	12		168"(4267mm)	TARA-48G8-W	S	JG4		5909.34	7748.60	6605.27	8624.10
10	12		174"(4420mm)	TARA-48H4-W	S	JG4		6093.90	7990.95	6819.08	8905.64
10	14		180"(4572mm)	TARA-48J0-W	S	JG4		6278.74	8235.21	7033.23	9189.42
6	10	54"(1372mm)	126"(3200mm)	TARA-54C6-W	S	JG4		\$5434.04	\$ 7077.26	\$5996.46	\$ 7761.21
6	10		132"(3353mm)	TARA-54D2-W	S	JG4		5634.71	7325.04	6229.18	8049.24
10	10		138"(3505mm)	TARA-54D8-W	S	JG4		5835.65	7574.74	6462.24	8339.52
10	10		144"(3658mm)	TARA-54E4-W	S	JG4		6036.88	7826.36	6695.64	8632.05
10	10		150"(3810mm)	TARA-54F0-W	S	JG4		6238.37	8079.89	6929.37	8926.82
10	12		156"(3962mm)	TARA-54F6-W	S	JG4		6440.15	8335.34	7163.44	9223.84
10	12		162"(4115mm)	TARA-54G2-W	S	JG4		6642.20	8592.71	7397.84	9523.11
10	12		168"(4267mm)	TARA-54G8-W	S	JG4		6844.53	8852.00	7632.59	9824.62
10	14		174"(4420mm)	TARA-54H4-W	S	JG4		7047.13	9113.21	7867.66	10128.38
10	14		180"(4572mm)	TARA-54J0-W	S	JG4		7250.01	9376.33	8103.08	10434.39
6	10	60"(1524mm)	126"(3200mm)	TARA-60C6-W	S	JG4		\$5973.65	\$ 7779.34	\$6605.59	\$ 8536.85
6	10		132"(3353mm)	TARA-60D2-W	S	JG4		6192.36	8045.98	6859.58	8847.11
10	10		138"(3505mm)	TARA-60D8-W	S	JG4		6411.34	8314.54	7113.91	9159.61
10	10		144"(3658mm)	TARA-60E4-W	S	JG4		6630.60	8585.01	7368.57	9474.36
10	10		150"(3810mm)	TARA-60F0-W	S	JG4		6850.14	8857.41	7623.57	9791.36
10	12		156"(3962mm)	TARA-60F6-W	S	JG4		7069.95	9131.72	7878.91	10110.60
10	12		162"(4115mm)	TARA-60G2-W	S	JG4		7290.04	9407.95	8134.58	10432.09
10	12		168"(4267mm)	TARA-60G8-W	S	JG4		7510.41	9686.09	8390.59	10755.83
10	14		174"(4420mm)	TARA-60H4-W	S	JG4		7731.05	9966.16	8646.94	11081.81
10	14		180"(4572mm)	TARA-60J0-W	S	JG4		7951.97	10248.14	8903.63	11410.04

*Recommended seating capacity based upon 27"(686mm) per chair.

Planes Conference Tables — Two-Piece Tops — Interior Leg — Wood

Pebble

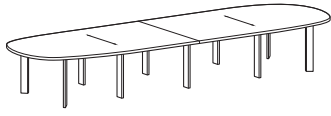

TARP

Features

- Includes 1 3/16" (30mm) thick tops, interior leg bases and hardware.
- Standard table height is 29" (737mm).
- Wood veneer top with 3mm wood edgeband or knife wood edge.
- Table top seam is 1mm edgeband.
- Interior legs are painted aluminum.
- Interior leg is 1 1/8" (29mm) x 3 1/4" (83mm).
- Optional cable base is available:
 - 42" (1067mm) deep and deeper tables will ship with 14" (356mm) x 14" (356mm) cable base
 - Two piece tops will include one cable base to be centered on seam under table top.
 - Cable base and table top(s) are wood veneer and can be specified in different surface colors and edge trim colors.
 - Refer to Specification Guide for use guidelines.
- Optional Flip top unit electrical modules are separately specified. Refer to electrical components for appropriate product specification.
- Available with glides only; 1/2" (13mm) height adjustment.
- Depth and width shown in nominal dimensions.
- Ships unassembled.

Specification Tips

- Tables with multiple-piece tops have equal sized pieces.
- The following Planes products are separately specified:
 - Grommets (field cut openings)
 - Flip top unit electrical modules
 - Horizontal wire management
- Refer to Specification Guide for seating capacities with Cable Base Option and leg locations.

To Order, Specify:

1) Product number, including:

① Wood Edge Option:

- K** Edgeband
- U** Knife

② Flip Top Unit Cutout(s):

- N** None
- F** Center – single-sided/4 outlets, add **\$66.26** list
- V** Left/Right – single-sided/4 outlets, add **\$132.52** list
- J** Center – 6 single-sided/outlets, add **\$66.26** list
- K** Left/Right – single-sided/6 outlets, add **\$132.52** list
- M** Center – double-sided/8 outlets, add **\$66.26** list
- P** Left/Right – double-sided/8 outlets, add **\$132.52** list
- Q** Center – double-sided/12 outlets, add **\$66.26** list
- T** Left/Right – double-sided/12 outlets, add **\$132.52** list

③ Cable Base Option:

- N** None
- C** Cable Base, add **\$698.87** list

2) Wood finish color.

3) Base trim color.

4) Wood finish color – Cable Base

Note: **\$45.78** upcharge (list) for Metallic and accent trim colors.

Planes Conference Tables — Two-Piece Tops — Interior Leg — Wood

Pebble

No. of Legs	Seating Capacity*	Depth	Width	Number	①	②	③	Wood Group A		Wood Group B	
								K	U	K	U
6	10	42"(1067mm)	126"(3200mm)	TARP-42C6-W	S	JG4		\$4115.14	\$ 5433.42	\$4538.53	\$ 5970.24
6	10		132"(3353mm)	TARP-42D2-W	S	JG4		4279.73	5643.49	4728.71	6213.82
6	10		138"(3505mm)	TARP-42D8-W	S	JG4		4444.60	5855.47	4919.23	6459.66
6	10		144"(3658mm)	TARP-42E4-W	S	JG4		4609.74	6069.36	5110.09	6707.74
10	10		150"(3810mm)	TARP-42F0-W	S	JG4		4775.16	6285.18	5301.28	6958.07
10	10		156"(3962mm)	TARP-42F6-W	S	JG4		4940.86	6502.91	5492.82	7210.64
10	10		162"(4115mm)	TARP-42G2-W	S	JG4		5106.83	6722.57	5684.68	7465.46
10	10		168"(4267mm)	TARP-42G8-W	S	JG4		5273.09	6944.14	5876.89	7722.53
10	12		174"(4420mm)	TARP-42H4-W	S	JG4		5439.61	7167.62	6069.43	7981.84
10	12		180"(4572mm)	TARP-42J0-W	S	JG4		5606.42	7393.03	6262.31	8243.40
6	10	48"(1219mm)	126"(3200mm)	TARP-48C6-W	S	JG4		\$4625.12	\$ 6105.87	\$5118.02	\$ 6716.25
6	10		132"(3353mm)	TARP-48D2-W	S	JG4		4807.75	6334.79	5329.48	6982.06
6	10		138"(3505mm)	TARP-48D8-W	S	JG4		4990.66	6565.63	5541.27	7250.12
6	10		144"(3658mm)	TARP-48E4-W	S	JG4		5173.84	6798.39	5753.39	7520.42
10	10		150"(3810mm)	TARP-48F0-W	S	JG4		5357.30	7033.06	5965.86	7792.97
10	10		156"(3962mm)	TARP-48F6-W	S	JG4		5541.03	7269.66	6178.66	8067.77
10	10		162"(4115mm)	TARP-48G2-W	S	JG4		5725.05	7508.17	6391.79	8344.81
10	10		168"(4267mm)	TARP-48G8-W	S	JG4		5909.34	7748.60	6605.27	8624.10
10	12		174"(4420mm)	TARP-48H4-W	S	JG4		6093.90	7990.95	6819.08	8905.64
10	12		180"(4572mm)	TARP-48J0-W	S	JG4		6278.74	8235.21	7033.23	9189.42
6	10	54"(1372mm)	126"(3200mm)	TARP-54C6-W	S	JG4		\$5434.04	\$ 7077.26	\$5996.46	\$ 7761.21
6	10		132"(3353mm)	TARP-54D2-W	S	JG4		5634.71	7325.04	6229.18	8049.24
6	10		138"(3505mm)	TARP-54D8-W	S	JG4		5835.65	7574.74	6462.24	8339.52
6	10		144"(3658mm)	TARP-54E4-W	S	JG4		6036.88	7826.36	6695.64	8632.05
10	10		150"(3810mm)	TARP-54F0-W	S	JG4		6238.37	8079.89	6929.37	8926.82
10	10		156"(3962mm)	TARP-54F6-W	S	JG4		6440.15	8335.34	7163.44	9223.84
10	10		162"(4115mm)	TARP-54G2-W	S	JG4		6642.20	8592.71	7397.84	9523.11
10	10		168"(4267mm)	TARP-54G8-W	S	JG4		6844.53	8852.00	7632.59	9824.62
10	12		174"(4420mm)	TARP-54H4-W	S	JG4		7047.13	9113.21	7867.66	10128.38
10	12		180"(4572mm)	TARP-54J0-W	S	JG4		7250.01	9376.33	8103.08	10434.39
6	10	60"(1524mm)	126"(3200mm)	TARP-60C6-W	S	JG4		\$5973.65	\$ 7779.34	\$6605.59	\$ 8536.85
6	10		132"(3353mm)	TARP-60D2-W	S	JG4		6192.36	8045.98	6859.58	8847.11
6	10		138"(3505mm)	TARP-60D8-W	S	JG4		6411.34	8314.54	7113.91	9159.61
6	10		144"(3658mm)	TARP-60E4-W	S	JG4		6630.60	8585.01	7368.57	9474.36
10	10		150"(3810mm)	TARP-60F0-W	S	JG4		6850.14	8857.41	7623.57	9791.36
10	10		156"(3962mm)	TARP-60F6-W	S	JG4		7069.95	9131.72	7878.91	10110.60
10	10		162"(4115mm)	TARP-60G2-W	S	JG4		7290.04	9407.95	8134.58	10432.09
10	10		168"(4267mm)	TARP-60G8-W	S	JG4		7510.41	9686.09	8390.59	10755.83
10	12		174"(4420mm)	TARP-60H4-W	S	JG4		7731.05	9966.16	8646.94	11081.81
10	12		180"(4572mm)	TARP-60J0-W	S	JG4		7951.97	10248.14	8903.63	11410.04

*Recommended seating capacity based upon 27"(686mm) per chair.

Planes Conference Tables — Two-Piece Tops — Interior Leg — Wood

Hexagon

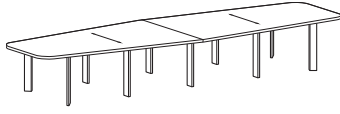

TARX

Features

- Includes 1 3/16" (30mm) thick tops, interior leg bases and hardware.
- Standard table height is 29" (737mm).
- Wood veneer top with 3mm wood edgeband or knife wood edge.
- Table top seam is 1mm edgeband.
- Interior legs are painted aluminum.
- Interior leg is 1 1/8" (29mm) x 3 1/4" (83mm).
- Optional cable base is available:
 - 42" (1067mm) deep and deeper tables will ship with 14" (356mm) x 14" (356mm) cable base
 - Two piece tops will include one cable base to be centered on seam under table top.
 - Cable base and table top(s) are wood veneer and can be specified in different surface colors and edge trim colors.
 - Refer to Specification Guide for use guidelines.
- Optional Flip top unit electrical modules are separately specified. Refer to electrical components for appropriate product specification.
- Available with glides only; 1/2" (13mm) height adjustment.
- Depth and width shown in nominal dimensions.
- Ships unassembled.

Specification Tips

- Tables with multiple-piece tops have equal sized pieces.
- The following Planes products are separately specified:
 - Grommets (field cut openings)
 - Flip top unit electrical modules
 - Horizontal wire management
- Refer to Specification Guide for seating capacities with Cable Base Option and leg locations.

To Order, Specify:

1) Product number, including:

① Wood Edge Option:

- K** Edgeband
- U** Knife

② Flip Top Unit Cutout(s):

- N** None
- F** Center – single-sided/4 outlets, add **\$66.26** list
- V** Left/Right – single-sided/4 outlets, add **\$132.52** list
- J** Center – single-sided/6 outlets, add **\$66.26** list
- K** Left/Right – single-sided/6 outlets, add **\$132.52** list
- M** Center – double-sided/8 outlets, add **\$66.26** list
- P** Left/Right – double-sided/8 outlets, add **\$132.52** list
- Q** Center – double-sided/12 outlets, add **\$66.26** list
- T** Left/Right – double-sided/12 outlets, add **\$132.52** list

③ Cable Base Option:

- N** None
- C** Cable Base, add **\$698.87** list

2) Wood finish color.

3) Base trim color.

4) Wood finish color – Cable Base

Note: **\$45.78** upcharge (list) for Metallic and accent trim colors.

Planes Conference Tables — Two-Piece Tops — Interior Leg — Wood

Hexagon

No. of Legs	Seating Capacity*	Depth	Width	Number	①	②	③	Wood Group A		Wood Group B	
								K	U	K	U
6	10	42"(1067mm)	126"(3200mm)	TARX-42C6-W	S	JG4		\$4115.14	\$ 5433.42	\$4538.53	\$ 5970.24
6	10		132"(3353mm)	TARX-42D2-W	S	JG4		4279.73	5643.49	4728.71	6213.82
6	10		138"(3505mm)	TARX-42D8-W	S	JG4		4444.60	5855.47	4919.23	6459.66
6	10		144"(3658mm)	TARX-42E4-W	S	JG4		4609.74	6069.36	5110.09	6707.74
10	10		150"(3810mm)	TARX-42F0-W	S	JG4		4775.16	6285.18	5301.28	6958.07
10	10		156"(3962mm)	TARX-42F6-W	S	JG4		4940.86	6502.91	5492.82	7210.64
10	10		162"(4115mm)	TARX-42G2-W	S	JG4		5106.83	6722.57	5684.68	7465.46
10	10		168"(4267mm)	TARX-42G8-W	S	JG4		5273.09	6944.14	5876.89	7722.53
10	12		174"(4420mm)	TARX-42H4-W	S	JG4		5439.61	7167.62	6069.43	7981.84
10	12		180"(4572mm)	TARX-42J0-W	S	JG4		5606.42	7393.03	6262.31	8243.40
6	10	48"(1219mm)	126"(3200mm)	TARX-48C6-W	S	JG4		\$4625.12	\$ 6105.87	\$5118.02	\$ 6716.25
6	10		132"(3353mm)	TARX-48D2-W	S	JG4		4807.75	6334.79	5329.48	6982.06
6	10		138"(3505mm)	TARX-48D8-W	S	JG4		4990.66	6565.63	5541.27	7250.12
6	10		144"(3658mm)	TARX-48E4-W	S	JG4		5173.84	6798.39	5753.39	7520.42
10	10		150"(3810mm)	TARX-48F0-W	S	JG4		5357.30	7033.06	5965.86	7792.97
10	10		156"(3962mm)	TARX-48F6-W	S	JG4		5541.03	7269.66	6178.66	8067.77
10	10		162"(4115mm)	TARX-48G2-W	S	JG4		5725.05	7508.17	6391.79	8344.81
10	10		168"(4267mm)	TARX-48G8-W	S	JG4		5909.34	7748.60	6605.27	8624.10
10	12		174"(4420mm)	TARX-48H4-W	S	JG4		6093.90	7990.95	6819.08	8905.64
10	12		180"(4572mm)	TARX-48J0-W	S	JG4		6278.74	8235.21	7033.23	9189.42
6	10	54"(1372mm)	126"(3200mm)	TARX-54C6-W	S	JG4		\$5434.04	\$ 7077.26	\$5996.46	\$ 7761.21
6	10		132"(3353mm)	TARX-54D2-W	S	JG4		5634.71	7325.04	6229.18	8049.24
6	10		138"(3505mm)	TARX-54D8-W	S	JG4		5835.65	7574.74	6462.24	8339.52
6	10		144"(3658mm)	TARX-54E4-W	S	JG4		6036.88	7826.36	6695.64	8632.05
10	10		150"(3810mm)	TARX-54F0-W	S	JG4		6238.37	8079.89	6929.37	8926.82
10	10		156"(3962mm)	TARX-54F6-W	S	JG4		6440.15	8335.34	7163.44	9223.84
10	10		162"(4115mm)	TARX-54G2-W	S	JG4		6642.20	8592.71	7397.84	9523.11
10	10		168"(4267mm)	TARX-54G8-W	S	JG4		6844.53	8852.00	7632.59	9824.62
10	12		174"(4420mm)	TARX-54H4-W	S	JG4		7047.13	9113.21	7867.66	10128.38
10	12		180"(4572mm)	TARX-54J0-W	S	JG4		7250.01	9376.33	8103.08	10434.39
6	10	60"(1524mm)	126"(3200mm)	TARX-60C6-W	S	JG4		\$5973.65	\$ 7779.34	\$6605.59	\$ 8536.85
6	10		132"(3353mm)	TARX-60D2-W	S	JG4		6192.36	8045.98	6859.58	8847.11
6	10		138"(3505mm)	TARX-60D8-W	S	JG4		6411.34	8314.54	7113.91	9159.61
6	10		144"(3658mm)	TARX-60E4-W	S	JG4		6630.60	8585.01	7368.57	9474.36
10	10		150"(3810mm)	TARX-60F0-W	S	JG4		6850.14	8857.41	7623.57	9791.36
10	10		156"(3962mm)	TARX-60F6-W	S	JG4		7069.95	9131.72	7878.91	10110.60
10	10		162"(4115mm)	TARX-60G2-W	S	JG4		7290.04	9407.95	8134.58	10432.09
10	10		168"(4267mm)	TARX-60G8-W	S	JG4		7510.41	9686.09	8390.59	10755.83
10	12		174"(4420mm)	TARX-60H4-W	S	JG4		7731.05	9966.16	8646.94	11081.81
10	12		180"(4572mm)	TARX-60J0-W	S	JG4		7951.97	10248.14	8903.63	11410.04

*Recommended seating capacity based upon 27"(686mm) per chair.

Planes Conference Tables — Three-Piece Tops — Interior Leg — Laminate

Rectangular



TARA

Features

- Includes 1 3/16" (30mm) thick tops, interior leg bases and hardware.
- Standard table height is 29" (737mm).
- Laminate top with 3mm edgeband or knife edges.
- Table top seams are 1mm edgeband.
- Interior legs are painted aluminum.
- Interior leg is 1 1/8" (29mm) x 3 1/4" (83mm).
- Optional cable bases are available:
 - 42" (1067mm) deep and deeper tables will ship with 14" (356mm) x 14" (356mm) cable bases.
 - Three piece tops will include two cable bases to be centered on seams.
 - Cable base and table top(s) are laminate and can be specified in different surface colors and edge trim colors.
 - Refer to Specification Guide for use guidelines.
- Optional Flip top unit electrical modules are separately specified. Refer to electrical components for appropriate product specification.
- Available with glides only; 1/2" (13mm) height adjustment.
- Depth and width shown in nominal dimensions.
- Ships unassembled.

Specification Tips

- Tables with multiple-piece tops have equal sized pieces.
- The following Planes products are separately specified:
 - Grommets (field cut opening)
 - Flip top unit electrical modules
 - Horizontal wire management
- Refer to Specification Guide for seating capacities with Cable Base Option and leg locations.

To Order, Specify:

1) Product number, including:

① Edge Option:

J Edgeband

F Knife

② Flip Top Unit Cutout(s):

N None

F Center – single-sided/4 outlets, add **\$99.39** list

V Left/Right – single-sided/4 outlets, add **\$198.78** list

J Center – single-sided/6 outlets, add **\$99.39** list

K Left/Right – single-sided/6 outlets, add **\$198.78** list

M Center – double-sided/8 outlets, add **\$99.39** list

P Left/Right – double-sided/8 outlets, add **\$198.78** list

Q Center – double-sided/12 outlets, add **\$99.39** list

T Left/Right – double-sided/12 outlets, add **\$198.78** list

③ Cable Base Option:

N None

C Cable Bases (2), add **\$1397.74** list

2) Laminate surface color.

3) 1mm edgeband trim color.
(Cascade edge/multiple-tops only)*

4) Edge trim color.

5) Base trim color.

6) Laminate surface – Cable Bases

7) Edge trim color – Cable Bases

Note: **\$45.78** upcharge (list) for Metallic and accent trim colors.

Planes Conference Tables — Three-Piece Tops — Interior Leg — Laminate

Rectangular

No. of Legs	Seating Capacity*	Depth	Width	Number	①	②	③	Laminate A		Laminate B	
								J	F	J	F
8	14	42"(1067mm)	186"(4724mm)	TARA-42J6-L	S	JG4		\$3704.04	\$4362.28	\$4005.34	\$4663.58
8	14		192"(4877mm)	TARA-42K2-L	S	JG4		3815.66	4488.54	4126.69	4799.57
8	14		198"(5029mm)	TARA-42K8-L	S	JG4		3927.28	4614.80	4248.04	4935.56
14	14		204"(5182mm)	TARA-42L4-L	S	JG4		4038.90	4741.06	4369.39	5071.55
14	14		210"(5334mm)	TARA-42M0-L	S	JG4		4150.52	4867.32	4490.74	5207.54
14	14		216"(5486mm)	TARA-42M6-L	S	JG4		4262.14	4993.58	4612.09	5343.53
14	16		222"(5639mm)	TARA-42N2-L	S	JG4		4373.76	5119.84	4733.44	5479.52
14	16		228"(5791mm)	TARA-42N8-L	S	JG4		4485.38	5246.10	4854.79	5615.51
14	16		234"(5944mm)	TARA-42P4-L	S	JG4		4597.00	5372.36	4976.14	5751.50
14	16		240"(6096mm)	TARA-42Q0-L	S	JG4		4708.62	5498.62	5097.49	5887.49
14	16		246"(6248mm)	TARA-42Q6-L	S	JG4		4820.24	5624.88	5218.84	6023.48
14	16		252"(6401mm)	TARA-42R2-L	S	JG4		4931.86	5751.14	5340.19	6159.47
14	18		258"(6553mm)	TARA-42R8-L	S	JG4		5043.48	5877.40	5461.54	6295.46
14	18		264"(6706mm)	TARA-42S4-L	S	JG4		5226.24	6003.66	5654.03	6431.45
14	20		270"(6858mm)	TARA-42T0-L	S	JG4		5337.86	6129.92	5775.38	6567.44
8	14	48"(1219mm)	186"(4724mm)	TARA-48J6-L	S	JG4		\$4158.96	\$4831.84	\$4503.35	\$5176.23
8	14		192"(4877mm)	TARA-48K2-L	S	JG4		4282.62	4970.14	4638.13	5325.65
8	14		198"(5029mm)	TARA-48K8-L	S	JG4		4406.28	5108.44	4772.91	5475.07
14	14		204"(5182mm)	TARA-48L4-L	S	JG4		4529.94	5246.74	4907.69	5624.49
14	14		210"(5334mm)	TARA-48M0-L	S	JG4		4653.60	5385.04	5042.47	5773.91
14	14		216"(5486mm)	TARA-48M6-L	S	JG4		4777.26	5523.34	5177.25	5923.33
14	16		222"(5639mm)	TARA-48N2-L	S	JG4		4900.92	5661.64	5312.03	6072.75
14	16		228"(5791mm)	TARA-48N8-L	S	JG4		5024.58	5799.94	5446.81	6222.17
14	16		234"(5944mm)	TARA-48P4-L	S	JG4		5148.24	5938.24	5581.59	6371.59
14	16		240"(6096mm)	TARA-48Q0-L	S	JG4		5271.90	6076.54	5716.37	6521.01
14	16		246"(6248mm)	TARA-48Q6-L	S	JG4		5395.56	6214.84	5851.15	6670.43
14	16		252"(6401mm)	TARA-48R2-L	S	JG4		5519.22	6353.14	5985.93	6819.85
14	18		258"(6553mm)	TARA-48R8-L	S	JG4		5642.88	6491.44	6120.71	6969.27
14	18		264"(6706mm)	TARA-48S4-L	S	JG4		5766.54	6629.74	6255.49	7118.69
14	20		270"(6858mm)	TARA-48T0-L	S	JG4		5890.20	6768.04	6390.27	7268.11
8	14	54"(1372mm)	186"(4724mm)	TARA-54J6-L	S	JG4		\$4542.74	\$5301.40	\$4930.22	\$5688.88
8	14		192"(4877mm)	TARA-54K2-L	S	JG4		4678.44	5451.74	5078.43	5851.73
8	14		198"(5029mm)	TARA-54K8-L	S	JG4		4814.14	5602.08	5226.64	6014.58
14	14		204"(5182mm)	TARA-54L4-L	S	JG4		4949.84	5752.42	5374.85	6177.43
14	14		210"(5334mm)	TARA-54M0-L	S	JG4		5085.54	5902.76	5523.06	6340.28
14	14		216"(5486mm)	TARA-54M6-L	S	JG4		5221.24	6053.10	5671.27	6503.13
14	16		222"(5639mm)	TARA-54N2-L	S	JG4		5356.94	6203.44	5819.48	6665.98
14	16		228"(5791mm)	TARA-54N8-L	S	JG4		5492.64	6353.78	5967.69	6828.83
14	16		234"(5944mm)	TARA-54P4-L	S	JG4		5628.34	6504.12	6115.90	6991.68
14	16		240"(6096mm)	TARA-54Q0-L	S	JG4		5764.04	6654.46	6264.11	7154.53
14	16		246"(6248mm)	TARA-54Q6-L	S	JG4		5899.74	6804.80	6412.32	7317.38
14	16		252"(6401mm)	TARA-54R2-L	S	JG4		6035.44	6955.14	6560.53	7480.23
14	18		258"(6553mm)	TARA-54R8-L	S	JG4		6171.14	7105.48	6708.74	7643.08
14	18		264"(6706mm)	TARA-54S4-L	S	JG4		6306.84	7255.82	6856.95	7805.93
14	20		270"(6858mm)	TARA-54T0-L	S	JG4		6442.54	7406.16	7005.16	7968.78
8	14	60"(1524mm)	186"(4724mm)	TARA-60J6-L	S	JG4		\$4926.53	\$5770.96	\$5357.10	\$6201.53
8	14		192"(4877mm)	TARA-60K2-L	S	JG4		5074.27	5933.34	5518.74	6377.81
8	14		198"(5029mm)	TARA-60K8-L	S	JG4		5222.01	6095.72	5680.38	6554.09
14	14		204"(5182mm)	TARA-60L4-L	S	JG4		5369.75	6258.10	5842.02	6730.37
14	14		210"(5334mm)	TARA-60M0-L	S	JG4		5517.49	6420.48	6003.66	6906.65
14	14		216"(5486mm)	TARA-60M6-L	S	JG4		5665.23	6582.86	6165.30	7082.93
14	16		222"(5639mm)	TARA-60N2-L	S	JG4		5812.97	6745.24	6326.94	7259.21
14	16		228"(5791mm)	TARA-60N8-L	S	JG4		5960.71	6907.62	6488.58	7435.49
14	16		234"(5944mm)	TARA-60P4-L	S	JG4		6108.45	7070.00	6650.22	7611.77
14	16		240"(6096mm)	TARA-60Q0-L	S	JG4		6256.19	7232.38	6811.86	7788.05
14	16		246"(6248mm)	TARA-60Q6-L	S	JG4		6403.93	7394.76	6973.50	7964.33
14	16		252"(6401mm)	TARA-60R2-L	S	JG4		6551.67	7557.14	7135.14	8140.61
14	18		258"(6553mm)	TARA-60R8-L	S	JG4		6699.41	7719.52	7296.78	8316.89
14	18		264"(6706mm)	TARA-60S4-L	S	JG4		6847.15	7881.90	7458.42	8493.17
14	20		270"(6858mm)	TARA-60T0-L	S	JG4		6994.89	8044.28	7620.06	8669.45

*Recommended seating capacity based upon 27"(686mm) per chair.

Planes Conference Tables — Three-Piece Tops — Interior Leg — Laminate

Pebble



TARP

Features

- Includes 1 3/16" (30mm) thick tops, interior leg bases and hardware.
- Standard table height is 29" (737mm).
- Laminate top with 3mm edgeband or knife edges.
- Table top seams are 1mm edgeband.
- Interior legs are painted aluminum.
- Interior leg is 1 1/8" (29mm) x 3 1/4" (83mm).
- Optional cable bases are available :
 - 42" (1067mm) deep and deeper tables will ship with 14" (356mm) x 14" (356mm) cable bases.
 - Three piece tops will include two cable bases to be centered on seams.
 - Cable base and table top(s) are laminate and can be specified in different surface colors and edge trim colors.
 - Refer to Specification Guide for use guidelines.
- Optional Flip top unit electrical modules are separately specified. Refer to electrical components for appropriate product specification.
- Available with glides only; 1/2" (13mm) height adjustment.
- Depth and width shown in nominal dimensions.
- Ships unassembled.

Specification Tips

- Tables with multiple-piece tops have equal sized pieces.
- The following Planes products are separately specified:
 - Grommets (field cut opening)
 - Flip top unit electrical modules
 - Horizontal wire management
- Refer to Specification Guide for seating capacities with Cable Base Option and leg locations.

To Order, Specify:

1) Product number, including:

① Edge Option:

- J** Edgeband
- F** Knife

② Flip Top Unit Cutout(s):

- N** None
- F** Center – single-sided/4 outlets, add **\$99.39** list
- V** Left/Right – single-sided/4 outlets, add **\$198.78** list
- J** Center – single-sided/6 outlets, add **\$99.39** list
- K** Left/Right – single-sided/6 outlets, add **\$198.78** list
- M** Center – double-sided/8 outlets, add **\$99.39** list
- P** Left/Right – double-sided/8 outlets, add **\$198.78** list
- Q** Center – double-sided/12 outlets, add **\$99.39** list
- T** Left/Right – double-sided/12 outlets, add **\$198.78** list

③ Cable Base Option:

- N** None
- C** Cable Bases (2), add **\$1397.74** list

- 2) Laminate surface color.
- 3) 1mm edgeband trim color.
(Cascade edge/multiple-tops only)*
- 4) Edge trim color.
- 5) Base trim color.
- 6) Laminate surface – Cable Bases
- 7) Edge trim color – Cable Bases

Note: **\$45.78** upcharge (list) for Metallic and accent trim colors.

Planes Conference Tables — Three-Piece Tops — Interior Leg — Laminate

Pebble

No. of Legs	Seating Capacity*	Depth	Width	Number	①	②	③	Laminate A		Laminate B	
								J	F	J	F
8	14	42"(1067mm)	186"(4724mm)	TARP-42J6-L	S	JG4		\$3704.04	\$4362.28	\$4005.34	\$4663.58
8	14		192"(4877mm)	TARP-42K2-L	S	JG4		3815.66	4488.54	4126.69	4799.57
8	14		198"(5029mm)	TARP-42K8-L	S	JG4		3927.28	4614.80	4248.04	4935.56
10	14		204"(5182mm)	TARP-42L4-L	S	JG4		4038.90	4741.06	4369.39	5071.55
10	14		210"(5334mm)	TARP-42M0-L	S	JG4		4150.52	4867.32	4490.74	5207.54
10	14		216"(5486mm)	TARP-42M6-L	S	JG4		4262.14	4993.58	4612.09	5343.53
14	14		222"(5639mm)	TARP-42N2-L	S	JG4		4373.76	5119.84	4733.44	5479.52
14	14		228"(5791mm)	TARP-42N8-L	S	JG4		4485.38	5246.10	4854.79	5615.51
14	14		234"(5944mm)	TARP-42P4-L	S	JG4		4597.00	5372.36	4976.14	5751.50
14	14		240"(6096mm)	TARP-42Q0-L	S	JG4		4708.62	5498.62	5097.49	5887.49
14	14		246"(6248mm)	TARP-42Q6-L	S	JG4		4820.24	5624.88	5218.84	6023.48
14	14		252"(6401mm)	TARP-42R2-L	S	JG4		4931.86	5751.14	5340.19	6159.47
14	14		258"(6553mm)	TARP-42R8-L	S	JG4		5043.48	5877.40	5461.54	6295.46
14	14		264"(6706mm)	TARP-42S4-L	S	JG4		5155.10	6003.66	5582.89	6431.45
14	16		270"(6858mm)	TARP-42T0-L	S	JG4		5266.72	6129.92	5704.24	6567.44
8	14	48"(1219mm)	186"(4724mm)	TARP-48J6-L	S	JG4		\$4158.96	\$4831.84	\$4503.35	\$5176.23
8	14		192"(4877mm)	TARP-48K2-L	S	JG4		4282.62	4970.14	4638.13	5325.65
8	14		198"(5029mm)	TARP-48K8-L	S	JG4		4406.28	5108.44	4772.91	5475.07
8	14		204"(5182mm)	TARP-48L4-L	S	JG4		4529.94	5246.74	4907.69	5624.49
8	14		210"(5334mm)	TARP-48M0-L	S	JG4		4653.60	5385.04	5042.47	5773.91
8	14		216"(5486mm)	TARP-48M6-L	S	JG4		4777.26	5523.34	5177.25	5923.33
14	14		222"(5639mm)	TARP-48N2-L	S	JG4		4900.92	5661.64	5312.03	6072.75
14	14		228"(5791mm)	TARP-48N8-L	S	JG4		5024.58	5799.94	5446.81	6222.17
14	14		234"(5944mm)	TARP-48P4-L	S	JG4		5148.24	5938.24	5581.59	6371.59
14	14		240"(6096mm)	TARP-48Q0-L	S	JG4		5271.90	6076.54	5716.37	6521.01
14	14		246"(6248mm)	TARP-48Q6-L	S	JG4		5395.56	6214.84	5851.15	6670.43
14	14		252"(6401mm)	TARP-48R2-L	S	JG4		5519.22	6353.14	5985.93	6819.85
14	14		258"(6553mm)	TARP-48R8-L	S	JG4		5642.88	6491.44	6120.71	6969.27
14	14		264"(6706mm)	TARP-48S4-L	S	JG4		5766.54	6629.74	6255.49	7118.69
14	16		270"(6858mm)	TARP-48T0-L	S	JG4		5890.20	6768.04	6390.27	7268.11
8	14	54"(1372mm)	186"(4724mm)	TARP-54J6-L	S	JG4		\$4542.74	\$5301.40	\$4930.22	\$5688.88
8	14		192"(4877mm)	TARP-54K2-L	S	JG4		4678.44	5451.74	5078.43	5851.73
8	14		198"(5029mm)	TARP-54K8-L	S	JG4		4814.14	5602.08	5226.64	6014.58
8	14		204"(5182mm)	TARP-54L4-L	S	JG4		4949.84	5752.42	5374.85	6177.43
8	14		210"(5334mm)	TARP-54M0-L	S	JG4		5085.54	5902.76	5523.06	6340.28
8	14		216"(5486mm)	TARP-54M6-L	S	JG4		5221.24	6053.10	5671.27	6503.13
14	14		222"(5639mm)	TARP-54N2-L	S	JG4		5356.94	6203.44	5819.48	6665.98
14	14		228"(5791mm)	TARP-54N8-L	S	JG4		5492.64	6353.78	5967.69	6828.83
14	14		234"(5944mm)	TARP-54P4-L	S	JG4		5628.34	6504.12	6115.90	6991.68
14	14		240"(6096mm)	TARP-54Q0-L	S	JG4		5764.04	6654.46	6264.11	7154.53
14	14		246"(6248mm)	TARP-54Q6-L	S	JG4		5899.74	6804.80	6412.32	7317.38
14	14		252"(6401mm)	TARP-54R2-L	S	JG4		6035.44	6955.14	6560.53	7480.23
14	14		258"(6553mm)	TARP-54R8-L	S	JG4		6171.14	7105.48	6708.74	7643.08
14	14		264"(6706mm)	TARP-54S4-L	S	JG4		6306.84	7255.82	6856.95	7805.93
14	16		270"(6858mm)	TARP-54T0-L	S	JG4		6442.54	7406.16	7005.16	7968.78
8	14	60"(1524mm)	186"(4724mm)	TARP-60J6-L	S	JG4		\$4926.53	\$5770.96	\$5357.10	\$6201.53
8	14		192"(4877mm)	TARP-60K2-L	S	JG4		5074.27	5933.34	5518.74	6377.81
8	14		198"(5029mm)	TARP-60K8-L	S	JG4		5222.01	6095.72	5680.38	6554.09
8	14		204"(5182mm)	TARP-60L4-L	S	JG4		5369.75	6258.10	5842.02	6730.37
8	14		210"(5334mm)	TARP-60M0-L	S	JG4		5517.49	6420.48	6003.66	6906.65
8	14		216"(5486mm)	TARP-60M6-L	S	JG4		5665.23	6582.86	6165.30	7082.93
14	14		222"(5639mm)	TARP-60N2-L	S	JG4		5812.97	6745.24	6326.94	7259.21
14	14		228"(5791mm)	TARP-60N8-L	S	JG4		5960.71	6907.62	6488.58	7435.49
14	14		234"(5944mm)	TARP-60P4-L	S	JG4		6108.45	7070.00	6650.22	7611.77
14	14		240"(6096mm)	TARP-60Q0-L	S	JG4		6256.19	7232.38	6811.86	7788.05
14	14		246"(6248mm)	TARP-60Q6-L	S	JG4		6403.93	7394.76	6973.50	7964.33
14	14		252"(6401mm)	TARP-60R2-L	S	JG4		6551.67	7557.14	7135.14	8140.61
14	14		258"(6553mm)	TARP-60R8-L	S	JG4		6699.41	7719.52	7296.78	8316.89
14	14		264"(6706mm)	TARP-60S4-L	S	JG4		6847.15	7881.90	7458.42	8493.17
14	16		270"(6858mm)	TARP-60T0-L	S	JG4		6994.89	8044.28	7620.06	8669.45

*Recommended seating capacity based upon 27"(686mm) per chair.

Planes Conference Tables — Three-Piece Tops — Interior Leg — Laminate

Hexagon



TARX

Features

- Includes 1 3/16" (30mm) thick top, interior leg bases and hardware.
- Standard table height is 29" (737mm).
- Laminate top with 3mm edgeband or knife edges.
- Table top seams are 1mm edgeband.
- Interior legs are painted aluminum.
- Interior leg is 1 1/8" (29mm) x 3 1/4" (83mm).
- Optional cable bases are available :
 - 42" (1067mm) deep and deeper tables will ship with 14" (356mm) x 14" (356mm) cable bases.
 - Three piece tops will include two cable bases to be centered on seams.
 - Cable base and table top(s) are laminate and can be specified in different surface colors and edge trim colors.
 - Refer to Specification Guide for use guidelines.
- Optional Flip top unit electrical modules are separately specified. Refer to electrical components for appropriate product specification.
- Available with glides only; 1/2" (13mm) height adjustment.
- Depth and width shown in nominal dimensions.
- Ships unassembled.

Specification Tips

- Tables with multiple-piece tops have equal sized pieces.
- The following Planes products are separately specified:
 - Grommets (field cut opening)
 - Flip top unit electrical modules
 - Horizontal wire management
- Refer to Specification Guide for seating capacities with Cable Base Option and leg locations.

To Order, Specify:

1) Product number, including:

① Edge Option:

J Edgeband

F Knife

② Flip Top Unit Cutout(s):

N None

F Center – single-sided/4 outlets, add **\$99.39** list

V Left/Right – single-sided/4 outlets, add **\$198.78** list

J Center – single-sided/6 outlets, add **\$99.39** list

K Left/Right – single-sided/6 outlets, add **\$198.78** list

M Center – double-sided/8 outlets, add **\$99.39** list

P Left/Right – double-sided/8 outlets, add **\$198.78** list

Q Center – double-sided/12 outlets, add **\$99.39** list

T Left/Right – double-sided/12 outlets, add **\$198.78** list

③ Cable Base Option:

N None

C Cable Bases (2), add **\$1397.74** list

2) Laminate surface color.

3) 1mm edgeband trim color. (Cascade edge/multiple-tops only)*

4) Edge trim color.

5) Base trim color.

6) Laminate surface – Cable Bases

7) Edge trim color – Cable Bases

Note: **\$45.78** upcharge (list) for Metallic and accent trim colors.

Planes Conference Tables — Three-Piece Tops — Interior Leg — Laminate

Hexagon

No. of Legs	Seating Capacity*	Depth	Width	Number	①	②	③	Laminate A		Laminate B	
								J	F	J	F
8	14	42"(1067mm)	186"(4724mm)	TARX-42J6-L	S	JG4		\$3704.04	\$4362.28	\$4005.34	\$4663.58
8	14		192"(4877mm)	TARX-42K2-L	S	JG4		3815.66	4488.54	4126.69	4799.57
8	14		198"(5029mm)	TARX-42K8-L	S	JG4		3927.28	4614.80	4248.04	4935.56
10	14		204"(5182mm)	TARX-42L4-L	S	JG4		4038.90	4741.06	4369.39	5071.55
10	14		210"(5334mm)	TARX-42M0-L	S	JG4		4150.52	4867.32	4490.74	5207.54
10	14		216"(5486mm)	TARX-42M6-L	S	JG4		4262.14	4993.58	4612.09	5343.53
14	14		222"(5639mm)	TARX-42N2-L	S	JG4		4373.76	5119.84	4733.44	5479.52
14	14		228"(5791mm)	TARX-42N8-L	S	JG4		4485.38	5246.10	4854.79	5615.51
14	14		234"(5944mm)	TARX-42P4-L	S	JG4		4597.00	5372.36	4976.14	5751.50
14	14		240"(6096mm)	TARX-42Q0-L	S	JG4		4708.62	5498.62	5097.49	5887.49
14	14		246"(6248mm)	TARX-42Q6-L	S	JG4		4820.24	5624.88	5218.84	6023.48
14	14		252"(6401mm)	TARX-42R2-L	S	JG4		4931.86	5751.14	5340.19	6159.47
14	14		258"(6553mm)	TARX-42R8-L	S	JG4		5043.48	5877.40	5461.54	6295.46
14	14		264"(6706mm)	TARX-42S4-L	S	JG4		5155.10	6003.66	5582.89	6431.45
14	16		270"(6858mm)	TARX-42T0-L	S	JG4		5266.72	6129.92	5704.24	6567.44
8	14	48"(1219mm)	186"(4724mm)	TARX-48J6-L	S	JG4		\$4158.96	\$4831.84	\$4503.35	\$5176.23
8	14		192"(4877mm)	TARX-48K2-L	S	JG4		4282.62	4970.14	4638.13	5325.65
8	14		198"(5029mm)	TARX-48K8-L	S	JG4		4406.28	5108.44	4772.91	5475.07
8	14		204"(5182mm)	TARX-48L4-L	S	JG4		4529.94	5246.74	4907.69	5624.49
8	14		210"(5334mm)	TARX-48M0-L	S	JG4		4653.60	5385.04	5042.47	5773.91
8	14		216"(5486mm)	TARX-48M6-L	S	JG4		4777.26	5523.34	5177.25	5923.33
14	14		222"(5639mm)	TARX-48N2-L	S	JG4		4900.92	5661.64	5312.03	6072.75
14	14		228"(5791mm)	TARX-48N8-L	S	JG4		5024.58	5799.94	5446.81	6222.17
14	14		234"(5944mm)	TARX-48P4-L	S	JG4		5148.24	5938.24	5581.59	6371.59
14	14		240"(6096mm)	TARX-48Q0-L	S	JG4		5271.90	6076.54	5716.37	6521.01
14	14		246"(6248mm)	TARX-48Q6-L	S	JG4		5395.56	6214.84	5851.15	6670.43
14	14		252"(6401mm)	TARX-48R2-L	S	JG4		5519.22	6353.14	5985.93	6819.85
14	14		258"(6553mm)	TARX-48R8-L	S	JG4		5642.88	6491.44	6120.71	6969.27
14	14		264"(6706mm)	TARX-48S4-L	S	JG4		5766.54	6629.74	6255.49	7118.69
14	16		270"(6858mm)	TARX-48T0-L	S	JG4		5890.20	6768.04	6390.27	7268.11
8	14	54"(1372mm)	186"(4724mm)	TARX-54J6-L	S	JG4		\$4542.74	\$5301.40	\$4930.22	\$5688.88
8	14		192"(4877mm)	TARX-54K2-L	S	JG4		4678.44	5451.74	5078.43	5851.73
8	14		198"(5029mm)	TARX-54K8-L	S	JG4		4814.14	5602.08	5226.64	6014.58
8	14		204"(5182mm)	TARX-54L4-L	S	JG4		4949.84	5752.42	5374.85	6177.43
8	14		210"(5334mm)	TARX-54M0-L	S	JG4		5085.54	5902.76	5523.06	6340.28
8	14		216"(5486mm)	TARX-54M6-L	S	JG4		5221.24	6053.10	5671.27	6503.13
14	14		222"(5639mm)	TARX-54N2-L	S	JG4		5356.94	6203.44	5819.48	6665.98
14	14		228"(5791mm)	TARX-54N8-L	S	JG4		5492.64	6353.78	5967.69	6828.83
14	14		234"(5944mm)	TARX-54P4-L	S	JG4		5628.34	6504.12	6115.90	6991.68
14	14		240"(6096mm)	TARX-54Q0-L	S	JG4		5764.04	6654.46	6264.11	7154.53
14	14		246"(6248mm)	TARX-54Q6-L	S	JG4		5899.74	6804.80	6412.32	7317.38
14	14		252"(6401mm)	TARX-54R2-L	S	JG4		6035.44	6955.14	6560.53	7480.23
14	14		258"(6553mm)	TARX-54R8-L	S	JG4		6171.14	7105.48	6708.74	7643.08
14	14		264"(6706mm)	TARX-54S4-L	S	JG4		6306.84	7255.82	6856.95	7805.93
14	16		270"(6858mm)	TARX-54T0-L	S	JG4		6442.54	7406.16	7005.16	7968.78
8	14	60"(1524mm)	186"(4724mm)	TARX-60J6-L	S	JG4		\$4926.53	\$5770.96	\$5357.10	\$6201.53
8	14		192"(4877mm)	TARX-60K2-L	S	JG4		5074.27	5933.34	5518.74	6377.81
8	14		198"(5029mm)	TARX-60K8-L	S	JG4		5222.01	6095.72	5680.38	6554.09
8	14		204"(5182mm)	TARX-60L4-L	S	JG4		5369.75	6258.10	5842.02	6730.37
8	14		210"(5334mm)	TARX-60M0-L	S	JG4		5517.49	6420.48	6003.66	6906.65
8	14		216"(5486mm)	TARX-60M6-L	S	JG4		5665.23	6582.86	6165.30	7082.93
14	14		222"(5639mm)	TARX-60N2-L	S	JG4		5812.97	6745.24	6326.94	7259.21
14	14		228"(5791mm)	TARX-60N8-L	S	JG4		5960.71	6907.62	6488.58	7435.49
14	14		234"(5944mm)	TARX-60P4-L	S	JG4		6108.45	7070.00	6650.22	7611.77
14	14		240"(6096mm)	TARX-60Q0-L	S	JG4		6256.19	7232.38	6811.86	7788.05
14	14		246"(6248mm)	TARX-60Q6-L	S	JG4		6403.93	7394.76	6973.50	7964.33
14	14		252"(6401mm)	TARX-60R2-L	S	JG4		6551.67	7557.14	7135.14	8140.61
14	14		258"(6553mm)	TARX-60R8-L	S	JG4		6699.41	7719.52	7296.78	8316.89
14	14		264"(6706mm)	TARX-60S4-L	S	JG4		6847.15	7881.90	7458.42	8493.17
14	16		270"(6858mm)	TARX-60T0-L	S	JG4		6994.89	8044.28	7620.06	8669.45

*Recommended seating capacity based upon 27"(686mm) per chair.

Planes Conference Tables — Three-Piece Tops — Interior Leg — Wood

Rectangular



TARA

Features

- Includes 1 3/16" (30mm) thick tops, interior leg bases and hardware.
- Standard table height is 29" (737mm).
- Wood veneer top with 3mm wood edgeband or knife wood edge.
- Table top seams are 1mm edgeband.
- Interior legs are painted aluminum.
- Interior leg is 1 1/8" (29mm) x 3 1/4" (83mm).
- Optional cable bases are available :
 - 42" (1067mm) deep and deeper tables will ship with 14" (356mm) x 14" (356mm) cable bases.
 - Three piece tops will include two cable bases to be centered on seams.
 - Cable base and table top(s) are wood veneer and can be specified in different surface colors and edge trim colors.
 - Refer to Specification Guide for use guidelines.
- Optional Flip top unit electrical modules are separately specified. Refer to electrical components for appropriate product specification.
- Available with glides only; 1/2" (13mm) height adjustment.
- Depth and width shown in nominal dimensions.
- Ships unassembled.

Specification Tips

- Tables with multiple-piece tops have equal sized pieces.
- The following Planes products are separately specified:
 - Grommets (field cut opening)
 - Flip top unit electrical modules
 - Horizontal wire management
- Refer to Specification Guide for seating capacities with Cable Base Option and leg locations.

To Order, Specify:

1) Product number, including:

① Wood Edge Option:

- K** Edgeband
- U** Knife

② Flip Top Unit Cutout(s):

- N** None
- F** Center – single-sided/4 outlets, add **\$99.39** list
- V** Left/Right – single-sided/4 outlets, add **\$198.78** list
- J** Center – single-sided/6 outlets, add **\$99.39** list
- K** Left/Right – single-sided/6 outlets, add **\$198.78** list
- M** Center – double-sided/8 outlets, add **\$99.39** list
- P** Left/Right – double-sided/8 outlets, add **\$198.78** list
- Q** Center – double-sided/12 outlets, add **\$99.39** list
- T** Left/Right – double-sided/12 outlets, add **\$198.78** list

③ Cable Base Option:

- N** None
- C** Cable Bases(2), add **\$1397.74** list

2) Wood finish color.

3) Base trim color.

4) Wood finish color – Cable Bases

Note: **\$45.78** upcharge (list) for Metallic and accent trim colors.

Planes Conference Tables — Three-Piece Tops — Interior Leg — Wood

Rectangular

No. of Legs	Seating Capacity*	Depth	Width	Number	①	②	③	Wood Group A		Wood Group B	
								K	U	K	U
8	14	42"(1067mm)	186"(4724mm)	TARA-42J6-W	S	JG4		\$ 6117.05	\$ 7644.21	\$ 6799.08	\$ 8531.06
8	14		192"(4877mm)	TARA-42K2-W	S	JG4		6284.40	7866.06	6992.63	8789.72
8	14		198"(5029mm)	TARA-42K8-W	S	JG4		6452.04	8089.82	7186.52	9050.61
14	14		204"(5182mm)	TARA-42L4-W	S	JG4		6619.95	8315.50	7380.75	9313.76
14	14		210"(5334mm)	TARA-42M0-W	S	JG4		6788.13	8543.09	7575.32	9579.15
14	14		216"(5486mm)	TARA-42M6-W	S	JG4		6956.60	8772.61	7770.22	9846.79
14	16		222"(5639mm)	TARA-42N2-W	S	JG4		7125.33	9004.04	7965.46	10116.67
14	16		228"(5791mm)	TARA-42N8-W	S	JG4		7294.35	9237.39	8161.03	10388.80
14	16		234"(5944mm)	TARA-42P4-W	S	JG4		7463.64	9472.66	8356.94	10663.18
14	16		240"(6096mm)	TARA-42Q0-W	S	JG4		7633.21	9709.85	8553.19	10939.80
14	16		246"(6248mm)	TARA-42Q6-W	S	JG4		7803.06	9948.95	8749.78	11218.67
14	16		252"(6401mm)	TARA-42R2-W	S	JG4		7973.18	10189.97	8946.70	11499.79
14	18		258"(6553mm)	TARA-42R8-W	S	JG4		8143.58	10432.92	9143.96	11783.15
14	18		264"(6706mm)	TARA-42S4-W	S	JG4		8314.25	10677.78	9341.56	12068.76
14	20		270"(6858mm)	TARA-42T0-W	S	JG4		8485.20	10924.55	9539.49	12356.61
8	14	48"(1219mm)	186"(4724mm)	TARA-48J6-W	S	JG4		\$ 6917.35	\$ 8505.25	\$ 7701.20	\$ 9499.31
8	14		192"(4877mm)	TARA-48K2-W	S	JG4		7102.75	8745.96	7916.02	9780.19
8	14		198"(5029mm)	TARA-48K8-W	S	JG4		7288.42	8988.57	8131.18	10063.31
14	14		204"(5182mm)	TARA-48L4-W	S	JG4		7474.37	9233.11	8346.68	10348.68
14	14		210"(5334mm)	TARA-48M0-W	S	JG4		7660.59	9479.57	8562.51	10636.29
14	14		216"(5486mm)	TARA-48M6-W	S	JG4		7847.09	9727.94	8778.68	10926.15
14	16		222"(5639mm)	TARA-48N2-W	S	JG4		8033.87	9978.23	8995.19	11218.26
14	16		228"(5791mm)	TARA-48N8-W	S	JG4		8220.92	10230.44	9212.03	11512.61
14	16		234"(5944mm)	TARA-48P4-W	S	JG4		8408.25	10484.57	9429.21	11809.21
14	16		240"(6096mm)	TARA-48Q0-W	S	JG4		8595.86	10740.62	9646.73	12108.06
14	16		246"(6248mm)	TARA-48Q6-W	S	JG4		8783.74	10998.58	9864.59	12409.15
14	16		252"(6401mm)	TARA-48R2-W	S	JG4		8971.90	11258.46	10082.78	12712.49
14	18		258"(6553mm)	TARA-48R8-W	S	JG4		9160.34	11520.26	10301.31	13018.08
14	18		264"(6706mm)	TARA-48S4-W	S	JG4		9349.05	11783.98	10520.17	13325.91
14	20		270"(6858mm)	TARA-48T0-W	S	JG4		9538.04	12049.62	10739.37	13635.99
8	14	54"(1372mm)	186"(4724mm)	TARA-54J6-W	S	JG4		\$ 8016.60	\$ 9665.23	\$ 8902.27	\$ 10766.50
8	14		192"(4877mm)	TARA-54K2-W	S	JG4		8220.03	9924.79	9138.36	11069.60
8	14		198"(5029mm)	TARA-54K8-W	S	JG4		8423.74	10186.27	9374.78	11374.94
14	14		204"(5182mm)	TARA-54L4-W	S	JG4		8627.73	10449.67	9611.55	11682.53
14	14		210"(5334mm)	TARA-54M0-W	S	JG4		8831.99	10714.98	9848.65	11992.37
14	14		216"(5486mm)	TARA-54M6-W	S	JG4		9036.53	10982.22	10086.09	12304.45
14	16		222"(5639mm)	TARA-54N2-W	S	JG4		9241.34	11251.37	10323.86	12618.78
14	16		228"(5791mm)	TARA-54N8-W	S	JG4		9446.44	11522.44	10561.98	12935.36
14	16		234"(5944mm)	TARA-54P4-W	S	JG4		9651.81	11795.42	10800.42	13254.18
14	16		240"(6096mm)	TARA-54Q0-W	S	JG4		9857.45	12070.33	11039.21	13575.25
14	16		246"(6248mm)	TARA-54Q6-W	S	JG4		10063.37	12347.15	11278.33	13898.57
14	16		252"(6401mm)	TARA-54R2-W	S	JG4		10269.57	12625.89	11517.79	14224.13
14	18		258"(6553mm)	TARA-54R8-W	S	JG4		10476.04	12906.55	11757.59	14551.94
14	18		264"(6706mm)	TARA-54S4-W	S	JG4		10682.81	13189.26	11997.75	14882.15
14	20		270"(6858mm)	TARA-54T0-W	S	JG4		10889.82	13473.63	12238.20	15214.30
8	14	60"(1524mm)	186"(4724mm)	TARA-60J6-W	S	JG4		\$ 8846.53	\$ 10555.90	\$ 9834.02	\$ 11764.38
8	14		192"(4877mm)	TARA-60K2-W	S	JG4		9068.00	10834.32	10091.38	12089.70
8	14		198"(5029mm)	TARA-60K8-W	S	JG4		9289.75	11114.66	10349.07	12417.26
14	14		204"(5182mm)	TARA-60L4-W	S	JG4		9511.78	11396.92	10607.11	12747.08
14	14		210"(5334mm)	TARA-60M0-W	S	JG4		9734.08	11681.09	10865.48	13079.14
14	14		216"(5486mm)	TARA-60M6-W	S	JG4		9956.66	11967.18	11124.18	13413.45
14	16		222"(5639mm)	TARA-60N2-W	S	JG4		10179.51	12255.19	11383.23	13750.00
14	16		228"(5791mm)	TARA-60N8-W	S	JG4		10402.64	12545.12	11642.61	14088.80
14	16		234"(5944mm)	TARA-60P4-W	S	JG4		10626.05	12836.97	11902.33	14429.85
14	16		240"(6096mm)	TARA-60Q0-W	S	JG4		10849.73	13130.73	12162.38	14773.14
14	16		246"(6248mm)	TARA-60Q6-W	S	JG4		11073.69	13426.41	12422.77	15118.68
14	16		252"(6401mm)	TARA-60R2-W	S	JG4		11297.93	13724.01	12683.50	15466.46
14	18		258"(6553mm)	TARA-60R8-W	S	JG4		11522.44	14023.53	12944.57	15816.50
14	18		264"(6706mm)	TARA-60S4-W	S	JG4		11747.23	14324.97	13205.97	16168.78
14	20		270"(6858mm)	TARA-60T0-W	S	JG4		11972.29	14628.32	13467.71	16523.30

*Recommended seating capacity based upon 27"(686mm) per chair.

Planes Conference Tables — Three-Piece Tops — Interior Leg — Wood

Pebble



TARP

Features

- Includes 1 3/16" (30mm) thick tops, interior leg bases and hardware.
- Standard table height is 29" (737mm).
- Wood veneer top with 3mm wood edgeband or knife wood edge.
- Table top seams are 1mm edgeband.
- Interior legs are painted aluminum.
- Interior leg is 1 1/8" (29mm) x 3 1/4" (83mm).
- Optional cable bases are available :
 - 42" (1067mm) deep and deeper tables will ship with 14" (356mm) x 14" (356mm) cable bases.
 - Three piece tops will include two cable bases to be centered on seams.
 - Cable base and table top(s) are wood veneer and can be specified in different surface colors and edge trim colors.
 - Refer to Specification Guide for use guidelines.
- Optional Flip top unit electrical modules are separately specified. Refer to electrical components for appropriate product specification.
- Available with glides only; 1/2" (13mm) height adjustment.
- Depth and width shown in nominal dimensions.
- Ships unassembled.

Specification Tips

- Tables with multiple-piece tops have equal sized pieces.
- The following Planes products are separately specified:
 - Grommets (field cut opening)
 - Flip top unit electrical modules
 - Horizontal wire management
- Refer to Specification Guide for seating capacities with Cable Base Option and leg locations.

To Order, Specify:

1) Product number, including:

① Wood Edge Option:

- K** Edgeband
- U** Knife

② Flip Top Unit Cutout(s):

- N** None
- F** Center – single-sided/4 outlets, add **\$99.39** list
- V** Left/Right – single-sided/4 outlets, add **\$198.78** list
- J** Center – single-sided/6 outlets, add **\$99.39** list
- K** Left/Right – single-sided/6 outlets, add **\$198.78** list
- M** Center – double-sided/8 outlets, add **\$99.39** list
- P** Left/Right – double-sided/8 outlets, add **\$198.78** list
- Q** Center – double-sided/12 outlets, add **\$99.39** list
- T** Left/Right – double-sided/12 outlets, add **\$198.78** list

③ Cable Base Option:

- N** None
- C** Cable Bases(2), add **\$1397.74** list

2) Wood finish color.

3) Base trim color.

4) Wood finish color – Cable Bases

Note: **\$45.78** upcharge (list) for Metallic and accent trim colors.

Planes Conference Tables — Three-Piece Tops — Interior Leg — Wood

Pebble

No. of Legs	Seating Capacity*	Depth	Width	Number				Wood Group A		Wood Group B	
					①	②	③	K	U	K	U
8	14	42"(1067mm)	186"(4724mm)	TARP-42J6-W	S	JG4	\$ 6117.05	\$ 7644.21	\$ 6799.08	\$ 8531.06	
8	14		192"(4877mm)	TARP-42K2-W	S	JG4	6284.40	7866.06	6992.63	8789.72	
8	14		198"(5029mm)	TARP-42K8-W	S	JG4	6452.04	8089.82	7186.52	9050.61	
10	14		204"(5182mm)	TARP-42L4-W	S	JG4	6619.95	8315.50	7380.75	9313.76	
10	14		210"(5334mm)	TARP-42M0-W	S	JG4	6788.13	8543.09	7575.32	9579.15	
10	14		216"(5486mm)	TARP-42M6-W	S	JG4	6956.60	8772.61	7770.22	9846.79	
14	14		222"(5639mm)	TARP-42N2-W	S	JG4	7125.33	9004.04	7965.46	10116.67	
14	14		228"(5791mm)	TARP-42N8-W	S	JG4	7294.35	9237.39	8161.03	10388.80	
14	14		234"(5944mm)	TARP-42P4-W	S	JG4	7463.64	9472.66	8356.94	10663.18	
14	14		240"(6096mm)	TARP-42Q0-W	S	JG4	7633.21	9709.85	8553.19	10939.80	
14	14		246"(6248mm)	TARP-42Q6-W	S	JG4	7803.06	9948.95	8749.78	11218.67	
14	14		252"(6401mm)	TARP-42R2-W	S	JG4	7973.18	10189.97	8946.70	11499.79	
14	14		258"(6553mm)	TARP-42R8-W	S	JG4	8143.58	10432.92	9143.96	11783.15	
14	14		264"(6706mm)	TARP-42S4-W	S	JG4	8314.25	10677.78	9341.56	12068.76	
14	16		270"(6858mm)	TARP-42T0-W	S	JG4	8485.20	10924.55	9539.49	12356.61	
8	14	48"(1219mm)	186"(4724mm)	TARP-48J6-W	S	JG4	\$ 6917.35	\$ 8505.25	\$ 7701.20	\$ 9499.31	
8	14		192"(4877mm)	TARP-48K2-W	S	JG4	7102.75	8745.96	7916.02	9780.19	
8	14		198"(5029mm)	TARP-48K8-W	S	JG4	7288.42	8988.57	8131.18	10063.31	
10	14		204"(5182mm)	TARP-48L4-W	S	JG4	7474.37	9233.11	8346.68	10348.68	
10	14		210"(5334mm)	TARP-48M0-W	S	JG4	7660.59	9479.57	8562.51	10636.29	
10	14		216"(5486mm)	TARP-48M6-W	S	JG4	7847.09	9727.94	8778.68	10926.15	
14	14		222"(5639mm)	TARP-48N2-W	S	144	8033.87	9978.23	8995.19	11218.26	
14	14		228"(5791mm)	TARP-48N8-W	S	JG4	8220.92	10230.44	9212.03	11512.61	
14	14		234"(5944mm)	TARP-48P4-W	S	JG4	8408.25	10484.57	9429.21	11809.21	
14	14		240"(6096mm)	TARP-48Q0-W	S	JG4	8595.86	10740.62	9646.73	12108.06	
14	14		246"(6248mm)	TARP-48Q6-W	S	JG4	8783.74	10998.58	9864.59	12409.15	
14	14		252"(6401mm)	TARP-48R2-W	S	JG4	8971.90	11258.46	10082.78	12712.49	
14	14		258"(6553mm)	TARP-48R8-W	S	JG4	9160.34	11520.26	10301.31	13018.08	
14	14		264"(6706mm)	TARP-48S4-W	S	JG4	9349.05	11783.98	10520.17	13325.91	
14	16		270"(6858mm)	TARP-48T0-W	S	JG4	9538.04	12049.62	10739.37	13635.99	
8	14	54"(1372mm)	186"(4724mm)	TARP-54J6-W	S	JG4	\$ 8016.60	\$ 9665.23	\$ 8902.27	\$ 10766.50	
8	14		192"(4877mm)	TARP-54K2-W	S	JG4	8220.03	9924.79	9138.36	11069.60	
8	14		198"(5029mm)	TARP-54K8-W	S	JG4	8423.74	10186.27	9374.78	11374.94	
10	14		204"(5182mm)	TARP-54L4-W	S	JG4	8627.73	10449.67	9611.55	11682.53	
10	14		210"(5334mm)	TARP-54M0-W	S	JG4	8831.99	10714.98	9848.65	11992.37	
10	14		216"(5486mm)	TARP-54M6-W	S	JG4	9036.53	10982.22	10086.09	12304.45	
14	14		222"(5639mm)	TARP-54N2-W	S	JG4	9241.34	11251.37	10323.86	12618.78	
14	14		228"(5791mm)	TARP-54N8-W	S	JG4	9446.44	11522.44	10561.98	12935.36	
14	14		234"(5944mm)	TARP-54P4-W	S	JG4	9651.81	11795.42	10800.42	13254.18	
14	14		240"(6096mm)	TARP-54Q0-W	S	JG4	9857.45	12070.33	11039.21	13575.25	
14	14		246"(6248mm)	TARP-54Q6-W	S	JG4	10063.37	12347.15	11278.33	13898.57	
14	14		252"(6401mm)	TARP-54R2-W	S	JG4	10269.57	12625.89	11517.79	14224.13	
14	14		258"(6553mm)	TARP-54R8-W	S	JG4	10476.04	12906.55	11757.59	14551.94	
14	14		264"(6706mm)	TARP-54S4-W	S	JG4	10682.80	13189.13	11997.73	14882.00	
14	16		270"(6858mm)	TARP-54T0-W	S	JG4	10889.82	13473.63	12238.20	15214.30	
8	14	60"(1524mm)	186"(4724mm)	TARP-60J6-W	S	JG4	\$ 8846.53	\$ 10555.90	\$ 9834.02	\$ 11764.38	
8	14		192"(4877mm)	TARP-60K2-W	S	JG4	9068.00	10834.32	10091.38	12089.70	
8	14		198"(5029mm)	TARP-60K8-W	S	JG4	9289.75	11114.66	10349.07	12417.26	
10	14		204"(5182mm)	TARP-60L4-W	S	JG4	9511.78	11396.92	10607.11	12747.08	
10	14		210"(5334mm)	TARP-60M0-W	S	JG4	9734.08	11681.09	10865.48	13079.14	
10	14		216"(5486mm)	TARP-60M6-W	S	JG4	9956.66	11967.18	11124.18	13413.45	
14	14		222"(5639mm)	TARP-60N2-W	S	JG4	10179.51	12255.19	11383.23	13750.00	
14	14		228"(5791mm)	TARP-60N8-W	S	JG4	10402.64	12545.12	11642.61	14088.80	
14	14		234"(5944mm)	TARP-60P4-W	S	JG4	10626.05	12836.97	11902.33	14429.85	
14	14		240"(6096mm)	TARP-60Q0-W	S	JG4	10849.73	13130.73	12162.38	14773.14	
14	14		246"(6248mm)	TARP-60Q6-W	S	JG4	11073.69	13426.41	12422.77	15118.68	
14	14		252"(6401mm)	TARP-60R2-W	S	JG4	11297.93	13724.01	12683.50	15466.46	
14	14		258"(6553mm)	TARP-60R8-W	S	JG4	11522.44	14023.53	12944.57	15816.50	
14	14		264"(6706mm)	TARP-60S4-W	S	JG4	11747.23	14324.97	13205.97	16168.78	
14	16		270"(6858mm)	TARP-60T0-W	S	JG4	11972.29	14628.32	13467.71	16523.30	

*Recommended seating capacity based upon 27"(686mm) per chair.

Planes Conference Tables — Three-Piece Tops — Interior Leg — Wood

Hexagon



TARX

Features

- Includes 1 3/16" (30mm) thick tops, interior leg bases and hardware.
- Standard table height is 29" (737mm).
- Wood veneer top with 3mm wood edgeband or knife wood edge.
- Table top seams are 1mm edgeband.
- Interior legs are painted aluminum.
- Interior leg is 1 1/8" (29mm) x 3 1/4" (83mm).
- Optional cable bases are available :
 - 42" (1067mm) deep and deeper tables will ship with 14" (356mm) x 14" (356mm) cable bases.
 - Three piece tops will include two cable bases to be centered on seams.
 - Cable base and table top(s) are wood veneer and can be specified in different surface colors and edge trim colors.
 - Refer to Specification Guide for use guidelines.
- Optional Flip top unit electrical modules are separately specified. Refer to electrical components for appropriate product specification.
- Available with glides only; 1/2" (13mm) height adjustment.
- Depth and width shown in nominal dimensions.
- Ships unassembled.

Specification Tips

- Tables with multiple-piece tops have equal sized pieces.
- The following Planes products are separately specified:
 - Grommets (field cut opening)
 - Flip top unit electrical modules
 - Horizontal wire management
- Refer to Specification Guide for seating capacities with Cable Base Option and leg locations.

To Order, Specify:

1) Product number, including:

① Wood Edge Option:

- K** Edgeband
- U** Knife

② Flip Top Unit Cutout(s):

- N** None
- F** Center – single-sided/4 outlets, add **\$99.39** list
- V** Left/Right – single-sided/4 outlets, add **\$198.78** list
- J** Center – single-sided/6 outlets, add **\$99.39** list
- K** Left/Right – single-sided/6 outlets, add **\$198.78** list
- M** Center – double-sided/8 outlets, add **\$99.39** list
- P** Left/Right – double-sided/8 outlets, add **\$198.78** list
- Q** Center – double-sided/12 outlets, add **\$99.39** list
- T** Left/Right – double-sided/12 outlets, add **\$198.78** list

③ Cable Base Option:

- N** None
- C** Cable Bases(2), add **\$1397.74** list

2) Wood finish color.

3) Base trim color.

4) Wood finish color – Cable Bases

Note: **\$45.78** upcharge (list) for Metallic and accent trim colors.

Planes Conference Tables — Three-Piece Tops — Interior Leg — Wood

Hexagon

No. of Legs	Seating Capacity*	Depth	Width	Number				Wood Group A		Wood Group B	
					①	②	③	K	U	K	U
8	14	42"(1067mm)	186"(4724mm)	TARX-42J6-W	S	JG4	\$ 6117.05	\$ 7644.21	\$ 6799.08	\$ 8531.06	
8	14		192"(4877mm)	TARX-42K2-W	S	JG4	6284.40	7866.06	6992.63	8789.72	
8	14		198"(5029mm)	TARX-42K8-W	S	JG4	6452.04	8089.82	7186.52	9050.61	
10	14		204"(5182mm)	TARX-42L4-W	S	JG4	6619.95	8315.50	7380.75	9313.76	
10	14		210"(5334mm)	TARX-42M0-W	S	JG4	6788.13	8543.09	7575.32	9579.15	
10	14		216"(5486mm)	TARX-42M6-W	S	JG4	6956.60	8772.61	7770.22	9846.79	
14	14		222"(5639mm)	TARX-42N2-W	S	JG4	7125.33	9004.04	7965.46	10116.67	
14	14		228"(5791mm)	TARX-42N8-W	S	JG4	7294.35	9237.39	8161.03	10388.80	
14	14		234"(5944mm)	TARX-42P4-W	S	JG4	7463.64	9472.66	8356.94	10663.18	
14	14		240"(6096mm)	TARX-42Q0-W	S	JG4	7633.21	9709.85	8553.19	10939.80	
14	14		246"(6248mm)	TARX-42Q6-W	S	JG4	7803.06	9948.95	8749.78	11218.67	
14	14		252"(6401mm)	TARX-42R2-W	S	JG4	7973.18	10189.97	8946.70	11499.79	
14	14		258"(6553mm)	TARX-42R8-W	S	JG4	8143.58	10432.92	9143.96	11783.15	
14	14		264"(6706mm)	TARX-42S4-W	S	JG4	8314.25	10677.78	9341.56	12068.76	
14	16		270"(6858mm)	TARX-42T0-W	S	JG4	8485.20	10924.55	9539.49	12356.61	
8	14	48"(1219mm)	186"(4724mm)	TARX-48J6-W	S	JG4	\$ 6917.35	\$ 8505.25	\$ 7701.20	\$ 9499.31	
8	14		192"(4877mm)	TARX-48K2-W	S	JG4	7102.75	8745.96	7916.02	9780.19	
8	14		198"(5029mm)	TARX-48K8-W	S	JG4	7288.42	8988.57	8131.18	10063.31	
10	14		204"(5182mm)	TARX-48L4-W	S	JG4	7474.37	9233.11	8346.68	10348.68	
10	14		210"(5334mm)	TARX-48M0-W	S	JG4	7660.59	9479.57	8562.51	10636.29	
10	14		216"(5486mm)	TARX-48M6-W	S	JG4	7847.09	9727.94	8778.68	10926.15	
14	14		222"(5639mm)	TARX-48N2-W	S	JG4	8033.87	9978.23	8995.19	11218.26	
14	14		228"(5791mm)	TARX-48N8-W	S	JG4	8220.92	10230.44	9212.03	11512.61	
14	14		234"(5944mm)	TARX-48P4-W	S	JG4	8408.25	10484.57	9429.21	11809.21	
14	14		240"(6096mm)	TARX-48Q0-W	S	JG4	8595.86	10740.62	9646.73	12108.06	
14	14		246"(6248mm)	TARX-48Q6-W	S	JG4	8783.74	10998.58	9864.59	12409.15	
14	14		252"(6401mm)	TARX-48R2-W	S	JG4	8971.90	11258.46	10082.78	12712.49	
14	14		258"(6553mm)	TARX-48R8-W	S	JG4	9160.34	11520.26	10301.31	13018.08	
14	14		264"(6706mm)	TARX-48S4-W	S	JG4	9349.05	11783.98	10520.17	13325.91	
14	16		270"(6858mm)	TARX-48T0-W	S	JG4	9538.04	12049.62	10739.37	13635.99	
8	14	54"(1372mm)	186"(4724mm)	TARX-54J6-W	S	JG4	\$ 8016.60	\$ 9665.23	\$ 8902.27	\$ 10766.50	
8	14		192"(4877mm)	TARX-54K2-W	S	JG4	8220.03	9924.79	9138.36	11069.60	
8	14		198"(5029mm)	TARX-54K8-W	S	JG4	8423.74	10186.27	9374.78	11374.94	
10	14		204"(5182mm)	TARX-54L4-W	S	JG4	8627.73	10449.67	9611.55	11682.53	
10	14		210"(5334mm)	TARX-54M0-W	S	JG4	8831.99	10714.98	9848.65	11992.37	
10	14		216"(5486mm)	TARX-54M6-W	S	JG4	9036.53	10982.22	10086.09	12304.45	
14	14		222"(5639mm)	TARX-54N2-W	S	JG4	9241.34	11251.37	10323.86	12618.78	
14	14		228"(5791mm)	TARX-54N8-W	S	JG4	9446.44	11522.44	10561.98	12935.36	
14	14		234"(5944mm)	TARX-54P4-W	S	JG4	9651.81	11795.42	10800.42	13254.18	
14	14		240"(6096mm)	TARX-54Q0-W	S	JG4	9857.45	12070.33	11039.21	13575.25	
14	14		246"(6248mm)	TARX-54Q6-W	S	JG4	10063.37	12347.15	11278.33	13898.57	
14	14		252"(6401mm)	TARX-54R2-W	S	JG4	10269.57	12625.89	11517.79	14224.13	
14	14		258"(6553mm)	TARX-54R8-W	S	JG4	10476.04	12906.55	11757.59	14551.94	
14	14		264"(6706mm)	TARX-54S4-W	S	JG4	10682.80	13189.13	11997.73	14882.00	
14	16		270"(6858mm)	TARX-54T0-W	S	JG4	10889.82	13473.63	12238.20	15214.30	
8	14	60"(1524mm)	186"(4724mm)	TARX-60J6-W	S	JG4	\$ 8846.53	\$ 10555.90	\$ 9834.02	\$ 11764.38	
8	14		192"(4877mm)	TARX-60K2-W	S	JG4	9068.00	10834.32	10091.38	12089.70	
8	14		198"(5029mm)	TARX-60K8-W	S	JG4	9289.75	11114.66	10349.07	12417.26	
10	14		204"(5182mm)	TARX-60L4-W	S	JG4	9511.78	11396.92	10607.11	12747.08	
10	14		210"(5334mm)	TARX-60M0-W	S	JG4	9734.08	11681.09	10865.48	13079.14	
10	14		216"(5486mm)	TARX-60M6-W	S	JG4	9956.66	11967.18	11124.18	13413.45	
14	14		222"(5639mm)	TARX-60N2-W	S	JG4	10179.51	12255.19	11383.23	13750.00	
14	14		228"(5791mm)	TARX-60N8-W	S	JG4	10402.64	12545.12	11642.61	14088.80	
14	14		234"(5944mm)	TARX-60P4-W	S	JG4	10626.05	12836.97	11902.33	14429.85	
14	14		240"(6096mm)	TARX-60Q0-W	S	JG4	10849.73	13130.73	12162.38	14773.14	
14	14		246"(6248mm)	TARX-60Q6-W	S	JG4	11073.69	13426.41	12422.77	15118.68	
14	14		252"(6401mm)	TARX-60R2-W	S	JG4	11297.93	13724.01	12683.50	15466.46	
14	14		258"(6553mm)	TARX-60R8-W	S	JG4	11522.44	14023.53	12944.57	15816.50	
14	14		264"(6706mm)	TARX-60S4-W	S	JG4	11747.23	14324.97	13205.97	16168.78	
14	16		270"(6858mm)	TARX-60T0-W	S	JG4	11972.29	14628.32	13467.71	16523.30	

*Recommended seating capacity based upon 27"(686mm) per chair.

Planes Conference Tables — Perimeter Leg — Laminate

Square and Rectangular – 2”(51mm) Edge

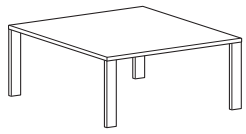

TARQ

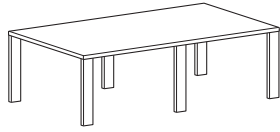

TARA

No. of Pieces	No. of Legs	Seating Capacity*	Depth	Width	Number	①	②	Laminate A	B
Square									
1	4	4	42”(1067mm)	42”(1067mm)	TARQ-4242-LJM	PG4N		\$ 843.66	\$ 912.14
1	4	4	48”(1219mm)	48”(1219mm)	TARQ-4848-LJM	PG4N		1057.26	1146.14
1	4	4	54”(1372mm)	54”(1372mm)	TARQ-5454-LJM	PG4N		1298.38	1410.38
1	4	4	60”(1524mm)	60”(1524mm)	TARQ-6060-LJM	PG4N		1567.02	1704.86
2	6	6	66”(1676mm)	66”(1676mm)	TARQ-6666-LJM	PG4		\$2545.14	\$2711.54
2	6	6	72”(1829mm)	72”(1829mm)	TARQ-7272-LJM	PG4		2936.85	3134.53
Rectangular									
1	4	4	30”(762mm)	60”(1524mm)	TARA-3060-LJM	PG4N		\$ 921.24	\$ 990.41
1	4	4		66”(1676mm)	TARA-3066-LJM	PG4N		991.48	1067.60
1	6	4		72”(1829mm)	TARA-3072-LJM	PG4N		1061.72	1144.79
1	4	4	36”(914mm)	60”(1524mm)	TARA-3660-LJM	PG4		\$1059.08	\$1142.15
1	4	4		66”(1676mm)	TARA-3666-LJM	PG4		1142.84	1234.25
1	4	4	42”(1067mm)	48”(1219mm)	TARA-4248-LJM	PG4		\$1002.36	\$1079.87
1	4	4		54”(1372mm)	TARA-4254-LJM	PG4		1099.64	1186.88
1	4	4		60”(1524mm)	TARA-4260-LJM	PG4		1196.92	1293.89
1	4	6		66”(1676mm)	TARA-4266-LJM	PG4		1294.20	1400.90
1	6	6		72”(1829mm)	TARA-4272-LJM	PG4		1391.48	1507.91
1	6	6		78”(1981mm)	TARA-4278-LJM	PG4		1488.76	1614.92
1	4	4	48”(1219mm)	54”(1372mm)	TARA-4854-LJM	PG4		\$1223.96	\$1323.71
1	4	4		60”(1524mm)	TARA-4860-LJM	PG4		1334.76	1445.63
1	4	6		66”(1676mm)	TARA-4866-LJM	PG4		1445.56	1567.55
1	6	6		72”(1829mm)	TARA-4872-LJM	PG4		1556.36	1689.47
1	6	8		78”(1981mm)	TARA-4878-LJM	PG4		1667.16	1811.39
1	4	4	54”(1372mm)	60”(1524mm)	TARA-5460-LJM	PG4		\$1472.60	\$1597.37
1	4	6		66”(1676mm)	TARA-5466-LJM	PG4		1596.92	1734.20
1	6	6		72”(1829mm)	TARA-5472-LJM	PG4		1721.24	1871.03
1	6	6		78”(1981mm)	TARA-5478-LJM	PG4		1845.56	2007.86
1	4	8	60”(1524mm)	66”(1676mm)	TARA-6066-LJM	PG4		\$1748.28	\$1900.85
1	6	8		72”(1829mm)	TARA-6072-LJM	PG4		1886.12	2052.59
1	6	8		78”(1981mm)	TARA-6078-LJM	PG4		2023.96	2204.33

Features

- Includes 2”(51mm) thick top, perimeter leg bases, and hardware.
- Standard table height is 30”(762mm).
- Laminate top with 3mm edgeband edges only.
- Table top seam is 3mm edgeband on multiple piece tops.
- Perimeter legs are painted aluminum.
- Perimeter leg is 1 3/8”(35mm) x 4”(102mm).
- Optional cable base can be specified for tables 36”(914mm) deep and deeper:
 - 36”(914mm) deep tables will ship with 8”(203mm) x 14”(356mm) cable base.
 - 42”(1067mm) deep and deeper tables will ship with 14”(356mm) x 14”(356mm) cable base.
 - One piece tops will include one cable base to be centered under table top.
 - Two piece tops will include one cable base to be centered on seam under table top.
 - Cable base and table top(s) are laminate and can be specified in different surface colors and edge trim colors.
 - Refer to Specification Guide for use guidelines.
- Optional Flip top unit electrical modules are separately specified. Refer to electrical components for appropriate product specification.
- Available with glides only; 1/2”(13mm) height adjustment.
- Depth and width shown in nominal dimensions.
- Ships unassembled.

Specification Tips

- Cable base not recommended to 30”(762mm) deep tables.
- Cable base for 36”(914mm) deep table is not compatible with Flip Top Cut Out Options (M) and (Q).
- Tables with multiple-piece tops have equal sized pieces.
- The following Planes products are separately specified:
 - Grommets (field cut opening)
 - Flip top unit electrical modules
 - Horizontal wire management
- Refer to Specification Guide for seating capacities with Cable Base Option and leg locations.

*Recommended seating capacity based upon 27”(686mm) per chair.

To Order, Specify:

1) Product number, including:

① Flip Top Unit Cutout(s):

Cutout options F, J, M, Q:
add \$33.13 list for one-piece top;
add \$66.26 list for two-piece tops.

- N** None
- F** Center – single-sided/4 outlets
- J** Center – single-sided/6 outlets
- M** Center – double-sided/8 outlets
- Q** Center – double-sided/12 outlets

② Cable Base Option:

- N** None
- C** Cable Base:
add \$662.73 list for 36” deep tables;
add \$698.87 list for 42” deep and deeper tables

- 2) Laminate surface color.
- 3) Edge trim color.
- 4) Base trim color.
- 5) Laminate Surface – Cable Base
- 6) Edge trim color – Cable Base

Note: \$45.78 upcharge (list) for Metallic and accent trim colors.

Planes Conference Tables — One-Piece Top — Perimeter Leg — Laminate

Rectangular – 2”(51mm) Edge

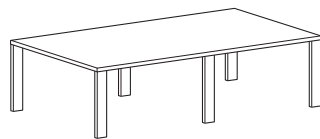

TARA

No. of Legs	Seating Capacity*	Depth	Width	Number	①	②	Laminate A	B
6	6	36”(914mm)	72”(1829mm)	TARA-3672-LJM	PG4		\$1226.60	\$1326.35
6	6		78”(1981mm)	TARA-3678-LJM	PG4		1310.36	1418.45
6	6		84”(2134mm)	TARA-3684-LJM	PG4		1394.12	1510.55
6	8		90”(2286mm)	TARA-3690-LJM	PG4		1477.88	1602.65
6	8		96”(2438mm)	TARA-3696-LJM	PG4		1561.64	1694.75
6	6	42”(1067mm)	84”(2134mm)	TARA-4284-LJM	PG4		\$1586.04	\$1721.93
6	8		90”(2286mm)	TARA-4290-LJM	PG4		1683.32	1828.94
6	8		96”(2438mm)	TARA-4296-LJM	PG4		1780.60	1935.95
6	8		102”(2591mm)	TARA-42A2-LJM	PG4		1877.88	2042.96
6	10		108”(2743mm)	TARA-42A8-LJM	PG4		1975.16	2149.97
6	10		114”(2896mm)	TARA-42B4-LJM	PG4		2072.44	2256.98
6	10		120”(3048mm)	TARA-42C0-LJM	PG4		2169.72	2363.99
6	6	48”(1219mm)	84”(2134mm)	TARA-4884-LJM	PG4		\$1777.96	\$1933.31
6	8		90”(2286mm)	TARA-4890-LJM	PG4		1888.76	2055.23
6	8		96”(2438mm)	TARA-4896-LJM	PG4		1999.56	2177.15
6	8		102”(2591mm)	TARA-48A2-LJM	PG4		2110.36	2299.07
6	10		108”(2743mm)	TARA-48A8-LJM	PG4		2221.16	2420.99
6	10		114”(2896mm)	TARA-48B4-LJM	PG4		2331.96	2542.91
6	10		120”(3048mm)	TARA-48C0-LJM	PG4		2442.76	2664.83
6	8	54”(1372mm)	84”(2134mm)	TARA-5484-LJM	PG4		\$1969.88	\$2144.69
6	10		90”(2286mm)	TARA-5490-LJM	PG4		2094.20	2281.52
6	10		96”(2438mm)	TARA-5496-LJM	PG4		2218.52	2418.35
6	10		102”(2591mm)	TARA-54A2-LJM	PG4		2342.84	2555.18
6	10		108”(2743mm)	TARA-54A8-LJM	PG4		2467.16	2692.01
6	10		114”(2896mm)	TARA-54B4-LJM	PG4		2591.48	2828.84
6	10		120”(3048mm)	TARA-54C0-LJM	PG4		2715.80	2965.67
6	10	60”(1524mm)	84”(2134mm)	TARA-6084-LJM	PG4		\$2161.80	\$2356.07
6	10		90”(2286mm)	TARA-6090-LJM	PG4		2299.64	2507.81
6	10		96”(2438mm)	TARA-6096-LJM	PG4		2437.48	2659.55
6	10		102”(2591mm)	TARA-60A2-LJM	PG4		2575.32	2811.29
6	10		108”(2743mm)	TARA-60A8-LJM	PG4		2713.16	2963.03
6	10		114”(2896mm)	TARA-60B4-LJM	PG4		2851.00	3114.77
6	10		120”(3048mm)	TARA-60C0-LJM	PG4		2988.84	3266.51

Features

- Includes 2”(51mm) thick top, perimeter leg bases, and hardware.
- Standard table height is 30”(762mm).
- Laminate top with 3mm edgeband edges only.
- Perimeter legs are painted aluminum.
- Perimeter leg is 1 3/8”(35mm) x 4”(102mm).
- Optional cable base can be specified for tables 36”(914mm) deep and deeper:
 - 36”(914mm) deep tables will ship with 8”(203mm) x 14”(356mm) cable base.
 - 42”(1067mm) deep and deeper tables will ship with 14”(356mm) x 14”(356mm) cable base.
 - One piece tops will include one cable base to be centered under table top.
 - Cable base and table top(s) are laminate and can be specified in different surface colors and edge trim colors.
 - Refer to Specification Guide for use guidelines.
- Optional Flip top unit electrical modules are separately specified. Refer to electrical components for appropriate product specification.
- Available with glides only; 1/2”(13mm) height adjustment.
- Depth and width shown in nominal dimensions.
- Ships unassembled.

Specification Tips

- The following Planes products are separately specified:
 - Grommets (field cut opening)
 - Flip top unit electrical modules
 - Horizontal wire management
- Refer to Specification Guide for seating capacities with Cable Base Option and leg locations.

*Recommended seating capacity based upon 27”(686mm) per chair.

To Order, Specify:

- 1) Product number, including:

① Flip Top Unit Cutout(s):

- N** None
- F** Center – single-sided/4 outlets, add \$198.78 list
- V** Left/Right – single-sided/4 outlets, add \$66.26 list
- J** Center – single-sided/6 outlets, add \$198.78 list
- K** Left/Right – single-sided/6 outlets, add \$66.26 list
- M** Center – double-sided/8 outlets, add \$198.78 list
- P** Left/Right – double-sided/8 outlets, add \$66.26 list
- Q** Center – double-sided/12 outlets, add \$198.78 list
- T** Left/Right – double-sided/12 outlets, add \$66.26 list

② Cable Base Option:

- N** None
- C** Cable Base: add \$662.73 list for 36” deep tables; add \$698.87 list for 42” deep and deeper tables

- 2) Laminate surface color.
- 3) Edge trim color.
- 4) Base trim color.
- 5) Laminate Surface – Cable Base
- 6) Edge trim color – Cable Base

Note: \$45.78 upcharge (list) for Metallic and accent trim colors.

Planes Conference Tables — Two-Piece Tops — Perimeter Leg — Laminate

Rectangular – 2”(51mm) Edge

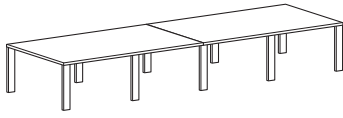

TARA

Features

- Includes 2”(51mm) thick top, perimeter leg bases, and hardware.
- Standard table height is 30”(762mm).
- Laminate top with 3mm edgeband edges only.
- Table top seam is 3mm edgeband.
- Perimeter legs are painted aluminum.
- Perimeter leg is 1 3/8”(35mm) x 4”(102mm).
- Optional cable base is available: :
 - 42”(1067mm) deep and deeper tables will ship with 14”(356mm) x 14”(356mm) cable base.
 - Two piece tops will include one cable base to be centered on seams under table top.
 - Cable base and table top(s) are laminate and can be specified in different surface colors and edge trim colors.
 - Refer to Specification Guide for use guidelines.
- Optional Flip top unit electrical modules are separately specified. Refer to electrical components for appropriate product specification.
- Available with glides only; 1/2”(13mm) height adjustment.
- Depth and width shown in nominal dimensions.
- Ships unassembled.

Specification Tips

- Tables with multiple-piece tops have equal sized pieces.
- The following Planes products are separately specified:
 - Grommets (field cut opening)
 - Flip top unit electrical modules
 - Horizontal wire management
- Refer to Specification Guide for seating capacities with Cable Base Option and leg locations.

To Order, Specify:

1) Product number, including:

① Flip Top Unit Cutout(s):

- N** None
- F** Center – single-sided/4 outlets, add **\$66.26** list
- V** Left/Right – single-sided/4 outlets, add **\$132.52** list
- J** Center – single-sided/6 outlets, add **\$66.26** list
- K** Left/Right – single-sided/6 outlets, add **\$132.52** list
- M** Center – double-sided/8 outlets, add **\$66.26** list
- P** Left/Right – double-sided/8 outlets, add **\$132.52** list
- Q** Center – double-sided/12 outlets, add **\$66.26** list
- T** Left/Right – double-sided/12 outlets, add **\$132.52** list

② Cable Base Option:

- N** None
- C** Cable Base, add **\$698.87** list

- 2) Laminate surface color.
- 3) Edge trim color.
- 4) Base trim color.
- 5) Laminate Surface – Cable Base
- 6) Edge trim color – Cable Base

Note: **\$45.78** upcharge (list) for Metallic and accent trim colors.

Planes Conference Tables — Two-Piece Tops — Perimeter Leg — Laminate

Rectangular – 2”(51mm) Edge

No. of Legs	Seating Capacity*	Depth	Width	Number	①	②	Laminate A	B
6	10	42”(1067mm)	126”(3200mm)	TARA-42C6-LJM	PG4		\$3172.33	\$3376.33
6	10		132”(3353mm)	TARA-42D2-LJM	PG4		3309.12	3522.85
10	10		138”(3505mm)	TARA-42D8-LJM	PG4		3445.91	3669.37
10	10		144”(3658mm)	TARA-42E4-LJM	PG4		3582.70	3815.89
10	10		150”(3810mm)	TARA-42F0-LJM	PG4		3719.49	3962.41
10	12		156”(3962mm)	TARA-42F6-LJM	PG4		3856.28	4108.93
10	12		162”(4115mm)	TARA-42G2-LJM	PG4		3993.07	4255.45
10	12		168”(4267mm)	TARA-42G8-LJM	PG4		4129.86	4401.97
10	12		174”(4420mm)	TARA-42H4-LJM	PG4		4266.65	4548.49
10	14		180”(4572mm)	TARA-42J0-LJM	PG4		4403.44	4695.01
6	10	48”(1219mm)	126”(3200mm)	TARA-48C6-LJM	PG4		\$3568.79	\$3801.98
6	10		132”(3353mm)	TARA-48D2-LJM	PG4		3725.30	3969.61
10	10		138”(3505mm)	TARA-48D8-LJM	PG4		3881.81	4137.24
10	10		144”(3658mm)	TARA-48E4-LJM	PG4		4038.32	4304.87
10	10		150”(3810mm)	TARA-48F0-LJM	PG4		4194.83	4472.50
10	12		156”(3962mm)	TARA-48F6-LJM	PG4		4351.34	4640.13
10	12		162”(4115mm)	TARA-48G2-LJM	PG4		4507.85	4807.76
10	12		168”(4267mm)	TARA-48G8-LJM	PG4		4664.36	4975.39
10	12		174”(4420mm)	TARA-48H4-LJM	PG4		4820.87	5143.02
10	14		180”(4572mm)	TARA-48J0-LJM	PG4		4977.38	5310.65
6	10	54”(1372mm)	126”(3200mm)	TARA-54C6-LJM	PG4		\$3965.28	\$4227.66
6	10		132”(3353mm)	TARA-54D2-LJM	PG4		4139.00	4413.89
10	10		138”(3505mm)	TARA-54D8-LJM	PG4		4312.72	4600.12
10	10		144”(3658mm)	TARA-54E4-LJM	PG4		4486.44	4786.35
10	10		150”(3810mm)	TARA-54F0-LJM	PG4		4660.16	4972.58
10	12		156”(3962mm)	TARA-54F6-LJM	PG4		4833.88	5158.81
10	12		162”(4115mm)	TARA-54G2-LJM	PG4		5007.60	5345.04
10	12		168”(4267mm)	TARA-54G8-LJM	PG4		5181.32	5531.27
10	14		174”(4420mm)	TARA-54H4-LJM	PG4		5355.04	5717.50
10	14		180”(4572mm)	TARA-54J0-LJM	PG4		5528.76	5903.73
6	10	60”(1524mm)	126”(3200mm)	TARA-60C6-LJM	PG4		\$4361.75	\$4653.32
6	10		132”(3353mm)	TARA-60D2-LJM	PG4		4552.70	4858.17
10	10		138”(3505mm)	TARA-60D8-LJM	PG4		4743.65	5063.02
10	10		144”(3658mm)	TARA-60E4-LJM	PG4		4934.60	5267.87
10	10		150”(3810mm)	TARA-60F0-LJM	PG4		5125.55	5472.72
10	12		156”(3962mm)	TARA-60F6-LJM	PG4		5316.50	5677.57
10	12		162”(4115mm)	TARA-60G2-LJM	PG4		5507.45	5882.42
10	12		168”(4267mm)	TARA-60G8-LJM	PG4		5698.40	6087.27
10	14		174”(4420mm)	TARA-60H4-LJM	PG4		5889.35	6292.12
10	14		180”(4572mm)	TARA-60J0-LJM	PG4		5633.20	6049.87

*Recommended seating capacity based upon 27”(686mm) per chair.

Planes Conference Tables — Three-Piece Tops — Perimeter Leg — Laminate

Rectangular – 2”(51mm) Edge



TARA

Features

- Includes 2”(51mm) thick top, perimeter leg bases, and hardware.
- Standard table height is 30”(762mm).
- Laminate top with 3mm edgeband edges only.
- Table top seams are 3mm edgeband.
- Perimeter legs are painted aluminum.
- Perimeter leg is 1 3/8”(35mm) x 4”(102mm).
- Optional cable bases are available:
 - 42”(1067mm) deep and deeper tables will ship with 14”(356mm) x 14”(356mm) cable base.
 - Three piece tops will include two cable bases to be centered on seams.
 - Cable base and table top(s) are laminate and can be specified in different surface colors and edge trim colors.
 - Refer to Specification Guide for use guidelines.
- Optional Flip top unit electrical modules are separately specified. Refer to electrical components for appropriate product specification.
- Available with glides only; 1/2”(13mm) height adjustment.
- Depth and width shown in nominal dimensions.
- Ships unassembled.

Specification Tips

- Tables with multiple-piece tops have equal sized pieces.
- The following Planes products are separately specified:
 - Grommets (field cut opening)
 - Flip top unit electrical modules
 - Horizontal wire management
- Refer to Specification Guide for seating capacities with Cable Base Option and leg locations.

To Order, Specify:

1) Product number, including:

① Flip Top Unit Cutout(s):

- N** None
- F** Center – single-sided/4 outlets, add **\$99.39** list
- V** Left/Right – single-sided/4 outlets, add **\$298.17** list
- J** Center – single-sided/6 outlets, add **\$99.39** list
- K** Left/Right – single-sided/6 outlets, add **\$298.17** list
- M** Center – double-sided/8 outlets, add **\$99.39** list
- P** Left/Right – double-sided/8 outlets, add **\$298.17** list
- Q** Center – double-sided/12 outlets, add **\$99.39** list
- T** Left/Right – double-sided/12 outlets, add **\$298.17** list

② Cable Base Option:

- N** None
- C** Cable Base (2), add **\$1397.74** list

- 2) Laminate surface color.
- 3) Edge trim color.
- 4) Base trim color.
- 5) Laminate Surface – Cable Base
- 6) Edge trim color – Cable Base

Note: **\$45.78** upcharge (list) for Metallic and accent trim colors.

Planes Conference Tables — Three-Piece Tops — Perimeter Leg — Laminate

Rectangular – 2”(51mm) Edge

No. of Legs	Seating Capacity*	Depth	Length	Number	①	②	Laminate A	B
8	14	42”(1067mm)	186”(4724mm)	TARA-42J6-LJM	PG4		\$4493.40	\$4794.70
8	14		192”(4877mm)	TARA-42K2-LJM	PG4		4630.19	4941.22
8	14		198”(5029mm)	TARA-42K8-LJM	PG4		4766.98	5087.74
14	14		204”(5182mm)	TARA-42L4-LJM	PG4		4903.77	5234.26
14	14		210”(5334mm)	TARA-42M0-LJM	PG4		5040.56	5380.78
14	14		216”(5486mm)	TARA-42M6-LJM	PG4		5177.35	5527.30
14	16		222”(5639mm)	TARA-42N2-LJM	PG4		5314.14	5673.82
14	16		228”(5791mm)	TARA-42N8-LJM	PG4		5450.93	5820.34
14	16		234”(5944mm)	TARA-42P4-LJM	PG4		5587.72	5966.86
14	16		240”(6096mm)	TARA-42Q0-LJM	PG4		5724.51	6113.38
14	16		246”(6248mm)	TARA-42Q6-LJM	PG4		5861.30	6259.90
14	16		252”(6401mm)	TARA-42R2-LJM	PG4		5998.09	6406.42
14	18		258”(6553mm)	TARA-42R8-LJM	PG4		6134.88	6552.94
14	18		264”(6706mm)	TARA-42S4-LJM	PG4		6271.67	6699.46
14	20		270”(6858mm)	TARA-42T0-LJM	PG4		6615.82	7053.34
8	14	48”(1219mm)	186”(4724mm)	TARA-48J6-LJM	PG4		\$5078.20	\$5422.59
8	14		192”(4877mm)	TARA-48K2-LJM	PG4		5232.24	5587.75
8	14		198”(5029mm)	TARA-48K8-LJM	PG4		5386.28	5752.91
14	14		204”(5182mm)	TARA-48L4-LJM	PG4		5540.32	5918.07
14	14		210”(5334mm)	TARA-48M0-LJM	PG4		5694.36	6083.23
14	14		216”(5486mm)	TARA-48M6-LJM	PG4		5848.40	6248.39
14	14		222”(5639mm)	TARA-48N2-LJM	PG4		6002.44	6413.55
14	16		228”(5791mm)	TARA-48N8-LJM	PG4		6156.48	6578.71
14	16		234”(5944mm)	TARA-48P4-LJM	PG4		6310.52	6743.87
14	16		240”(6096mm)	TARA-48Q0-LJM	PG4		6464.56	6909.03
14	16		246”(6248mm)	TARA-48Q6-LJM	PG4		6618.60	7074.19
14	16		252”(6401mm)	TARA-48R2-LJM	PG4		6772.64	7239.35
14	18		258”(6553mm)	TARA-48R8-LJM	PG4		6926.68	7404.51
14	18		264”(6706mm)	TARA-48S4-LJM	PG4		7080.72	7569.67
14	20		270”(6858mm)	TARA-48T0-LJM	PG4		7234.76	7734.83
8	14	54”(1372mm)	186”(4724mm)	TARA-54J6-LJM	PG4		\$5591.85	\$5979.33
8	14		192”(4877mm)	TARA-54K2-LJM	PG4		5763.11	6163.10
8	14		198”(5029mm)	TARA-54K8-LJM	PG4		5934.37	6346.87
14	14		204”(5182mm)	TARA-54L4-LJM	PG4		6105.63	6530.64
14	14		210”(5334mm)	TARA-54M0-LJM	PG4		6276.89	6714.41
14	14		216”(5486mm)	TARA-54M6-LJM	PG4		6448.15	6898.18
14	16		222”(5639mm)	TARA-54N2-LJM	PG4		6619.41	7081.95
14	16		228”(5791mm)	TARA-54N8-LJM	PG4		6790.67	7265.72
14	16		234”(5944mm)	TARA-54P4-LJM	PG4		6961.93	7449.49
14	16		240”(6096mm)	TARA-54Q0-LJM	PG4		7133.19	7633.26
14	16		246”(6248mm)	TARA-54Q6-LJM	PG4		7304.45	7817.03
14	16		252”(6401mm)	TARA-54R2-LJM	PG4		7475.71	8000.80
14	18		258”(6553mm)	TARA-54R8-LJM	PG4		7646.97	8184.57
14	18		264”(6706mm)	TARA-54S4-LJM	PG4		7818.23	8368.34
14	20		270”(6858mm)	TARA-54T0-LJM	PG4		7989.49	8552.11
8	14	60”(1524mm)	186”(4724mm)	TARA-60J6-LJM	PG4		\$6056.10	\$6486.67
8	14		192”(4877mm)	TARA-60K2-LJM	PG4		6244.59	6689.06
8	14		198”(5029mm)	TARA-60K8-LJM	PG4		6433.08	6891.45
14	14		204”(5182mm)	TARA-60L4-LJM	PG4		6621.57	7093.84
14	14		210”(5334mm)	TARA-60M0-LJM	PG4		6810.06	7296.23
14	14		216”(5486mm)	TARA-60M6-LJM	PG4		6998.55	7498.62
14	16		222”(5639mm)	TARA-60N2-LJM	PG4		7187.04	7701.01
14	16		228”(5791mm)	TARA-60N8-LJM	PG4		7375.53	7903.40
14	16		234”(5944mm)	TARA-60P4-LJM	PG4		7564.02	8105.79
14	16		240”(6096mm)	TARA-60Q0-LJM	PG4		7752.51	8308.18
14	16		246”(6248mm)	TARA-60Q6-LJM	PG4		7941.00	8510.57
14	16		252”(6401mm)	TARA-60R2-LJM	PG4		8129.49	8712.96
14	18		258”(6553mm)	TARA-60R8-LJM	PG4		8317.98	8915.35
14	18		264”(6706mm)	TARA-60S4-LJM	PG4		8506.47	9117.74
14	20		270”(6858mm)	TARA-60T0-LJM	PG4		8694.96	9320.13

*Recommended seating capacity based upon 27”(686mm) per chair.

Planes Conference Tables — Perimeter Leg — Wood

Square and Rectangular – 2”(51mm) Edge

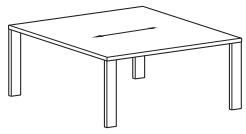

TARQ

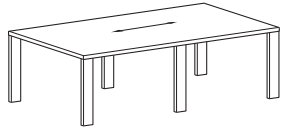

TARA

No. of Pieces	No. of Legs	Seating Capacity*	Depth	Width	Number	①	②	Wood Group A	Group B
Square									
1	4	4	42”(1067mm)	42”(1067mm)	TARQ-4242-WKM	PG4N		\$1355.38	\$1381.36
1	4	4	48”(1219mm)	48”(1219mm)	TARQ-4848-WKM	PG4N		1678.99	1721.26
1	4	4	54”(1372mm)	54”(1372mm)	TARQ-5454-WKM	PG4N		2042.42	2102.96
1	4	4	60”(1524mm)	60”(1524mm)	TARQ-6060-WKM	PG4N		2445.67	2526.46
2	6	6	66”(1676mm)	66”(1676mm)	TARQ-6666-WKM	PG4		\$3887.47	\$3990.49
2	6	6	72”(1829mm)	72”(1829mm)	TARQ-7272-WKM	PG4		4591.27	4718.50
Rectangular									
1	4	4	30”(762mm)	60”(1524mm)	TARA-3060-WKM	PG4N		\$1423.65	\$1501.55
1	4	4		66”(1676mm)	TARA-3066-WKM	PG4N		1542.07	1638.44
1	6	4		72”(1829mm)	TARA-3072-WKM	PG4N		1660.77	1775.67
1	4	4	36”(914mm)	60”(1524mm)	TARA-3660-WKM	PG4		\$1647.01	\$1758.90
1	4	4		66”(1676mm)	TARA-3666-WKM	PG4		1787.00	1920.59
1	4	4	42”(1067mm)	48”(1219mm)	TARA-4248-WKM	PG4		\$1548.08	\$1644.28
1	4	4		54”(1372mm)	TARA-4254-WKM	PG4		1709.09	1830.09
1	4	4		60”(1524mm)	TARA-4260-WKM	PG4		1870.37	2016.24
1	4	6		66”(1676mm)	TARA-4266-WKM	PG4		2031.93	2202.73
1	6	6	72”(1829mm)	72”(1829mm)	TARA-4272-WKM	PG4		2193.77	2389.55
1	6	6		78”(1981mm)	TARA-4278-WKM	PG4		2355.88	2576.71
1	4	4	48”(1219mm)	54”(1372mm)	TARA-4854-WKM	PG4		\$1910.88	\$2062.64
1	4	4		60”(1524mm)	TARA-4860-WKM	PG4		2093.73	2273.59
1	4	6		66”(1676mm)	TARA-4866-WKM	PG4		2276.86	2484.87
1	6	6		72”(1829mm)	TARA-4872-WKM	PG4		2460.27	2696.50
1	6	8		78”(1981mm)	TARA-4878-WKM	PG4		2643.95	2908.46
1	4	4	54”(1372mm)	60”(1524mm)	TARA-5460-WKM	PG4		\$2317.10	\$2530.93
1	4	6		66”(1676mm)	TARA-5466-WKM	PG4		2521.79	2767.02
1	6	6	72”(1829mm)	72”(1829mm)	TARA-5472-WKM	PG4		2726.77	3003.44
1	6	6		78”(1981mm)	TARA-5478-WKM	PG4		2932.02	3240.20
1	4	8	60”(1524mm)	66”(1676mm)	TARA-6066-WKM	PG4		\$2766.72	\$3049.16
1	6	8	72”(1829mm)	72”(1829mm)	TARA-6072-WKM	PG4		2993.27	3310.38
1	6	8		78”(1981mm)	TARA-6078-WKM	PG4		3220.08	3571.94

Features

- Includes 2”(51mm) thick top, perimeter leg bases, and hardware.
- Standard table height is 30”(762mm).
- Wood veneer top with 3mm wood edgeband edges.
- Table top seam is 3mm edgeband on multiple piece tops.
- Perimeter legs are painted aluminum.
- Perimeter leg is 1 3/8”(35mm) x 4”(102mm).
- Optional cable base can be specified for tables 36”(914mm) deep and deeper:
 - 36”(914mm) deep tables will ship with 8”(203mm) x 14”(356mm) cable base.
 - 42”(1067mm) deep and deeper tables will ship with 14”(356mm) x 14”(356mm) cable base.
 - One piece tops will include one cable base to be centered under table top.
 - Two piece tops will include one cable base to be centered on seam under table top.
- Cable base and table top(s) are wood veneer and can be specified in different surface colors and edge trim colors.
- Refer to Specification Guide for use guidelines.
- Optional Flip top unit electrical modules are separately specified. Refer to electrical components for appropriate product specification.
- Available with glides only; 1/2”(13mm) height adjustment.
- Depth and width shown in nominal dimensions.
- Ships unassembled.

Specification Tips

- Cable base for 36”(914mm) deep table is not compatible with Flip Top Cut Out Options (M) and (Q).
- Tables with multiple piece tops have equal sized pieces.
- The following Planes products are separately specified:
 - Grommets (field cut opening)
 - Flip top unit electrical modules
 - Horizontal wire management
- Refer to Specification Guide for seating capacities with Cable Base Option and leg locations.

*Recommended seating capacity based upon 27”(686mm) per chair.

To Order, Specify:

1) Product number, including:

① Flip Top Unit Cutout(s):

Cutout options **F, J, M, Q:**
 add \$31.33 list for one-piece top;
 add \$66.26 list for two-piece tops.

- N** None
- F** Center – single-sided/4 outlets
- J** Center – single-sided/6 outlets
- M** Center – double-sided/8 outlets
- Q** Center – double-sided/12 outlets

② Cable Base Option:

- N** None
- C** Cable Base: add \$662.73 list for 36” deep tables; add \$698.87 list for 42” deep and deeper tables

- 2) Wood finish color.
- 3) Base trim color.
- 4) Wood finish color – Cable Base

Note: \$45.78 upcharge (list) for Metallic and accent trim colors.

Planes Conference Tables — One-Piece Top — Perimeter Leg — Wood

Rectangular – 2”(51mm) Edge

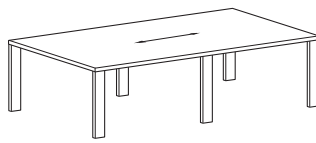

TARA

No. of Legs	Seating Capacity*	Depth	Width	Number	①	②	Wood Group A	Group B
6	6	36”(914mm)	72”(1829mm)	TARA-3672-WKM	PG4		\$1927.27	\$2082.61
6	6		78”(1981mm)	TARA-3678-WKM	PG4		2067.82	2244.97
6	6		84”(2134mm)	TARA-3684-WKM	PG4		2208.64	2407.67
6	8		90”(2286mm)	TARA-3690-WKM	PG4		2349.74	2570.71
6	8		96”(2438mm)	TARA-3696-WKM	PG4		2491.11	2734.08
6	6	42”(1067mm)	84”(2134mm)	TARA-4284-WKM	PG4		\$2518.27	\$2764.21
6	8		90”(2286mm)	TARA-4290-WKM	PG4		2680.94	2952.05
6	8		96”(2438mm)	TARA-4296-WKM	PG4		2843.88	3140.22
6	8		102”(2591mm)	TARA-42A2-WKM	PG4		3007.10	3328.73
6	10		108”(2743mm)	TARA-42A8-WKM	PG4		3170.60	3517.58
6	10		114”(2896mm)	TARA-42B4-WKM	PG4		3334.37	3706.76
6	10		120”(3048mm)	TARA-42C0-WKM	PG4		3498.42	3896.28
6	6	48”(1219mm)	84”(2134mm)	TARA-4884-WKM	PG4		\$2827.91	\$3120.75
6	8		90”(2286mm)	TARA-4890-WKM	PG4		3012.14	3333.39
6	8		96”(2438mm)	TARA-4896-WKM	PG4		3196.65	3546.36
6	8		102”(2591mm)	TARA-48A2-WKM	PG4		3381.44	3759.66
6	10		108”(2743mm)	TARA-48A8-WKM	PG4		3566.51	3973.31
6	10		114”(2896mm)	TARA-48B4-WKM	PG4		3751.85	4187.29
6	10		120”(3048mm)	TARA-48C0-WKM	PG4		3937.46	4401.61
6	8	54”(1372mm)	84”(2134mm)	TARA-5484-WKM	PG4		\$3137.54	\$3477.29
6	10		90”(2286mm)	TARA-5490-WKM	PG4		3343.35	3714.72
6	10		96”(2438mm)	TARA-5496-WKM	PG4		3549.43	3952.49
6	10		102”(2591mm)	TARA-54A2-WKM	PG4		3755.78	4190.60
6	10		108”(2743mm)	TARA-54A8-WKM	PG4		3962.41	4429.04
6	10		114”(2896mm)	TARA-54B4-WKM	PG4		4169.32	4667.82
6	10		120”(3048mm)	TARA-54C0-WKM	PG4		4376.51	4906.94
6	10	60”(1524mm)	84”(2134mm)	TARA-6084-WKM	PG4		\$3447.18	\$3833.83
6	10		90”(2286mm)	TARA-6090-WKM	PG4		3674.55	4096.06
6	10		96”(2438mm)	TARA-6096-WKM	PG4		3902.20	4358.63
6	10		102”(2591mm)	TARA-60A2-WKM	PG4		4130.12	4621.53
6	10		108”(2743mm)	TARA-60A8-WKM	PG4		4358.32	4884.77
6	10		114”(2896mm)	TARA-60B4-WKM	PG4		4586.80	5148.35
6	10		120”(3048mm)	TARA-60C0-WKM	PG4		4815.55	5412.27

Features

- Includes 2”(51mm) thick top, perimeter leg bases, and hardware.
- Standard table height is 30”(762mm).
- Wood veneer top with 3mm wood edgeband edges.
- Perimeter legs are painted aluminum.
- Perimeter leg is 1 3/8”(35mm) x 4”(102mm).
- Optional cable base can be specified for tables 36”(914mm) deep and deeper:
 - 36”(914mm) deep tables will ship with 8”(203mm) x 14”(356mm) cable base.
 - 42”(1067mm) deep and deeper tables will ship with 14”(356mm) x 14”(356mm) cable base.
 - One piece tops will include one cable base to be centered under table top.
 - Cable base and table top(s) are wood veneer and can be specified in different surface colors and edge trim colors.
 - Refer to Specification Guide for use guidelines.
- Optional Flip top unit electrical modules are separately specified. Refer to electrical components for appropriate product specification.
- Available with glides only; 1/2”(13mm) height adjustment.
- Depth and width shown in nominal dimensions.
- Ships unassembled.

Specification Tips

- The following Planes products are separately specified:
 - Grommets (field cut opening)
 - Flip top unit electrical modules
 - Horizontal wire management
- Refer to Specification Guide for seating capacities with Cable Base Option and leg locations.

*Recommended seating capacity based upon 27”(686mm) per chair.

To Order, Specify:

- 1) Product number, including:

① Flip Top Unit Cutout(s):

- N** None
- F** Center – single-sided/4 outlets, add \$31.33 list
- V** Left/Right – single-sided/4 outlets, add \$66.26 list
- J** Center – single-sided/6 outlets, add \$31.33 list
- K** Left/Right – single-sided/6 outlets, add \$66.26 list
- M** Center – double-sided/8 outlets, add \$31.33 list
- P** Left/Right – double-sided/8 outlets, add \$66.26 list
- Q** Center – double-sided/12 outlets, add \$31.33 list
- T** Left/Right – double-sided/12 outlets, add \$66.26 list

② Cable Base Option:

- N** None
- C** Cable Base: add \$662.73 list for 36” deep tables; add \$698.87 list for 42” deep and deeper tables

- 2) Wood finish color.
- 3) Base trim color.
- 4) Wood finish color – Cable Base

Note: \$45.78 upcharge (list) for Metallic and accent trim colors.

Planes Conference Tables — Two-Piece Tops — Perimeter Leg — Wood

Rectangular – 2”(51mm) Edge

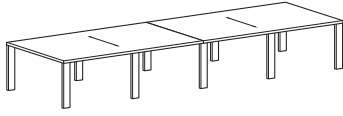

TARA

Features

- Includes 2”(51mm) thick top, perimeter leg bases, and hardware.
- Standard table height is 30”(762mm).
- Wood veneer top with 3mm wood edgeband edges.
- Table top seam is 3mm edgeband on multiple piece tops.
- Perimeter legs are painted aluminum.
- Perimeter leg is 1 3/8”(35mm) x 4”(102mm).
- Optional cable base is available:
 - 42”(1067mm) deep and deeper tables will ship with 14”(356mm) x 14”(356mm) cable base.
 - Two piece tops will include one cable base to be centered on seam under table top.
 - Cable base and table top(s) are wood veneer and can be specified in different surface colors and edge trim colors.
 - Refer to Specification Guide for use guidelines.
- Optional Flip top unit electrical modules are separately specified. Refer to electrical components for appropriate product specification.
- Available with glides only; 1/2”(13mm) height adjustment.
- Depth and width shown in nominal dimensions.
- Ships unassembled.

Specification Tips

- Tables with multiple-piece tops have equal sized pieces.
- The following Planes products are separately specified:
 - Grommets (field cut opening)
 - Flip top unit electrical modules
 - Horizontal wire management
- Refer to Specification Guide for seating capacities with Cable Base Option and leg locations.

To Order, Specify:

1) Product number, including:

① Flip Top Unit Cutout(s):

- N** None
- F** Center – single-sided/4 outlets, add **\$66.26** list
- V** Left/Right – single-sided/4 outlets, add **\$132.52** list
- J** Center – single-sided/6 outlets, add **\$66.26** list
- K** Left/Right – single-sided/6 outlets, add **\$132.52** list
- M** Center – double-sided/8 outlets, add **\$66.52** list
- P** Left/Right – double sided/8 outlets, add **\$132.52** list
- Q** Center – double-sided/12 outlets, add **\$66.52** list
- T** Left/Right – double-sided/12 outlets, add **\$132.52** list

② Cable Base Option:

- N** None
- C** Cable Base, add **\$698.87** list

2) Wood finish color.

3) Base trim color.

4) Wood finish color – Cable Base

Note: **\$45.78** upcharge (list) for Metallic and accent trim colors.

Planes Conference Tables — Two-Piece Tops — Perimeter Leg — Wood

Rectangular – 2”(51mm) Edge

No. of Legs	Seating Capacity*	Depth	Width	Number	①	②	Wood Group A	Group B
6	10	42”(1067mm)	126”(3200mm)	TARA-42C6-WKM	PG4		\$5040.26	\$ 5463.65
6	10		132”(3353mm)	TARA-42D2-WKM	PG4		5244.37	5693.35
10	10		138”(3505mm)	TARA-42D8-WKM	PG4		5448.76	5923.39
10	10		144”(3658mm)	TARA-42E4-WKM	PG4		5653.42	6153.77
10	10		150”(3810mm)	TARA-42F0-WKM	PG4		5858.36	6384.48
10	12		156”(3962mm)	TARA-42F6-WKM	PG4		6063.58	6615.54
10	12		162”(4115mm)	TARA-42G2-WKM	PG4		6269.07	6846.92
10	12		168”(4267mm)	TARA-42G8-WKM	PG4		6474.85	7078.65
10	12		174”(4420mm)	TARA-42H4-WKM	PG4		6680.89	7310.71
10	14		180”(4572mm)	TARA-42J0-WKM	PG4		6887.22	7543.11
6	10	48”(1219mm)	126”(3200mm)	TARA-48C6-WKM	PG4		\$5655.23	\$ 6148.13
6	10		132”(3353mm)	TARA-48D2-WKM	PG4		5887.11	6408.84
10	10		138”(3505mm)	TARA-48D8-WKM	PG4		6119.27	6669.88
10	10		144”(3658mm)	TARA-48E4-WKM	PG4		6351.70	6931.25
10	10		150”(3810mm)	TARA-48F0-WKM	PG4		6584.41	7192.97
10	12		156”(3962mm)	TARA-48F6-WKM	PG4		6817.39	7455.02
10	12		162”(4115mm)	TARA-48G2-WKM	PG4		7050.66	7717.40
10	12		168”(4267mm)	TARA-48G8-WKM	PG4		7284.20	7980.13
10	12		174”(4420mm)	TARA-48H4-WKM	PG4		7518.01	8243.19
10	14		180”(4572mm)	TARA-48J0-WKM	PG4		7752.10	8506.59
6	10	54”(1372mm)	126”(3200mm)	TARA-54C6-WKM	PG4		\$6270.23	\$ 6832.65
6	10		132”(3353mm)	TARA-54D2-WKM	PG4		6527.37	7121.84
10	10		138”(3505mm)	TARA-54D8-WKM	PG4		6784.78	7411.37
10	10		144”(3658mm)	TARA-54E4-WKM	PG4		7042.48	7701.24
10	10		150”(3810mm)	TARA-54F0-WKM	PG4		7300.44	7991.44
10	12		156”(3962mm)	TARA-54F6-WKM	PG4		7558.69	8281.98
10	12		162”(4115mm)	TARA-54G2-WKM	PG4		7817.21	8572.85
10	12		168”(4267mm)	TARA-54G8-WKM	PG4		8076.01	8864.07
10	14		174”(4420mm)	TARA-54H4-WKM	PG4		8335.08	9155.61
10	14		180”(4572mm)	TARA-54J0-WKM	PG4		8594.43	9447.50
6	10	60”(1524mm)	126”(3200mm)	TARA-60C6-WKM	PG4		\$6885.21	\$ 7517.15
6	10		132”(3353mm)	TARA-60D2-WKM	PG4		7167.63	7834.85
10	10		138”(3505mm)	TARA-60D8-WKM	PG4		7450.32	8152.89
10	10		144”(3658mm)	TARA-60E4-WKM	PG4		7733.29	8471.26
10	10		150”(3810mm)	TARA-60F0-WKM	PG4		8016.54	8789.97
10	12		156”(3962mm)	TARA-60F6-WKM	PG4		8300.06	9109.02
10	12		162”(4115mm)	TARA-60G2-WKM	PG4		8583.86	9428.40
10	12		168”(4267mm)	TARA-60G8-WKM	PG4		8867.94	9748.12
10	14		174”(4420mm)	TARA-60H4-WKM	PG4		9152.29	10068.18
10	14		180”(4572mm)	TARA-60J0-WKM	PG4		8989.82	9941.48

*Recommended seating capacity based upon 27”(686mm) per chair.

Planes Conference Tables — Three-Piece Tops — Perimeter Leg — Wood

Rectangular – 2”(51mm) Edge



TARA

Features

- Includes 2”(51mm) thick top, perimeter leg bases, and hardware.
- Standard table height is 30”(762mm).
- Wood veneer top with 3mm wood edgeband edges.
- Table top seams are 3mm edgeband on multiple piece tops.
- Perimeter legs are painted aluminum.
- Perimeter leg is 1 3/8”(35mm) x 4”(102mm).
- Optional cable bases are available:
 - 42”(1067mm) deep and deeper tables will ship with 14”(356mm) x 14”(356mm) cable base.
 - Three piece tops will include two cable bases to be centered on seams
 - Cable base and table top(s) are wood veneer and can be specified in different surface colors and edge trim colors.
 - Refer to Specification Guide for use guidelines.
- Optional Flip top unit electrical modules are separately specified. Refer to electrical components for appropriate product specification.
- Available with glides only; 1/2”(13mm) height adjustment.
- Depth and width shown in nominal dimensions.
- Ships unassembled.

Specification Tips

- Tables with multiple-piece tops have equal sized pieces.
- The following Planes products are separately specified:
 - Grommets (field installed)
 - Flip top unit electrical modules
 - Horizontal wire management
- Refer to Specification Guide for seating capacities with Cable Base Option and leg locations.

To Order, Specify:

1) Product number, including:

① Flip Top Unit Cutout(s):

- N** None
- F** Center – single-sided/4 outlets, add **\$99.39** list
- V** Left/Right – single-sided/4 outlets, add **\$198.78** list
- J** Center – single-sided/6 outlets, add **\$99.39** list
- K** Left/Right – single-sided/6 outlets, add **\$198.78** list
- M** Center – double-sided/8 outlets, add **\$99.39** list
- P** Left/Right – double-sided/8 outlets, add **\$198.78** list
- Q** Center – double-sided/12 outlets, add **\$99.39** list
- T** Left/Right – double-sided/12 outlets, add **\$198.78** list

② Cable Base Option:

- N** None
- C** Cable Bases(2), add **\$1397.74** list

2) Wood finish color.

3) Base trim color.

4) Wood finish color – Cable Base

Note: **\$45.78** upcharge (list) for Metallic and accent trim colors.

Planes Conference Tables — Three-Piece Tops — Perimeter Leg — Wood

Rectangular – 2”(51mm) Edge

No. of Legs	Seating Capacity*	Depth	Width	Number	①	②	Wood Group A	Group B
8	14	42”(1067mm)	186”(4724mm)	TARA-42J6-WKM	PG4		\$ 7378.18	\$ 8060.21
8	14		192”(4877mm)	TARA-42K2-WKM	PG4		7585.05	8293.28
8	14		198”(5029mm)	TARA-42K8-WKM	PG4		7792.21	8526.69
14	14		204”(5182mm)	TARA-42L4-WKM	PG4		7999.64	8760.44
14	14		210”(5334mm)	TARA-42M0-WKM	PG4		8207.34	8994.53
14	14		216”(5486mm)	TARA-42M6-WKM	PG4		8415.33	9228.95
14	16		222”(5639mm)	TARA-42N2-WKM	PG4		8623.58	9463.71
14	16		228”(5791mm)	TARA-42N8-WKM	PG4		8832.12	9698.80
14	16		234”(5944mm)	TARA-42P4-WKM	PG4		9040.93	9934.23
14	16		240”(6096mm)	TARA-42Q0-WKM	PG4		9250.02	10170.00
14	16		246”(6248mm)	TARA-42Q6-WKM	PG4		9459.39	10406.11
14	16		252”(6401mm)	TARA-42R2-WKM	PG4		9669.03	10642.55
14	18		258”(6553mm)	TARA-42R8-WKM	PG4		9878.95	10879.33
14	18		264”(6706mm)	TARA-42S4-WKM	PG4		10089.14	11116.45
14	20		270”(6858mm)	TARA-42T0-WKM	PG4		10299.61	11353.90
8	14	48”(1219mm)	186”(4724mm)	TARA-48J6-WKM	PG4		\$ 8371.91	\$ 9155.76
8	14		192”(4877mm)	TARA-48K2-WKM	PG4		8604.09	9417.36
8	14		198”(5029mm)	TARA-48K8-WKM	PG4		8836.54	9679.30
14	14		204”(5182mm)	TARA-48L4-WKM	PG4		9069.27	9941.58
14	14		210”(5334mm)	TARA-48M0-WKM	PG4		9302.27	10204.19
14	14		216”(5486mm)	TARA-48M6-WKM	PG4		9535.55	10467.14
14	16		222”(5639mm)	TARA-48N2-WKM	PG4		9769.11	10730.43
14	16		228”(5791mm)	TARA-48N8-WKM	PG4		10002.94	10994.05
14	16		234”(5944mm)	TARA-48P4-WKM	PG4		10237.05	11258.01
14	16		240”(6096mm)	TARA-48Q0-WKM	PG4		10471.44	11522.31
14	16		246”(6248mm)	TARA-48Q6-WKM	PG4		10706.10	11786.95
14	16		252”(6401mm)	TARA-48R2-WKM	PG4		10941.04	12051.92
14	18		258”(6553mm)	TARA-48R8-WKM	PG4		11176.26	12317.23
14	18		264”(6706mm)	TARA-48S4-WKM	PG4		11411.75	12582.87
14	20		270”(6858mm)	TARA-48T0-WKM	PG4		11647.52	12848.85
8	14	54”(1372mm)	186”(4724mm)	TARA-54J6-WKM	PG4		\$ 9365.64	\$ 10251.31
8	14		192”(4877mm)	TARA-54K2-WKM	PG4		9623.08	10541.41
8	14		198”(5029mm)	TARA-54K8-WKM	PG4		9880.80	10831.84
14	14		204”(5182mm)	TARA-54L4-WKM	PG4		10138.80	11122.62
14	14		210”(5334mm)	TARA-54M0-WKM	PG4		10397.07	11413.73
14	14		216”(5486mm)	TARA-54M6-WKM	PG4		10655.62	11705.18
14	16		222”(5639mm)	TARA-54N2-WKM	PG4		10914.44	11996.96
14	16		228”(5791mm)	TARA-54N8-WKM	PG4		11173.55	12289.09
14	16		234”(5944mm)	TARA-54P4-WKM	PG4		11432.93	12581.54
14	16		240”(6096mm)	TARA-54Q0-WKM	PG4		11692.58	12874.34
14	16		246”(6248mm)	TARA-54Q6-WKM	PG4		11952.51	13167.47
14	16		252”(6401mm)	TARA-54R2-WKM	PG4		12212.72	13460.94
14	18		258”(6553mm)	TARA-54R8-WKM	PG4		12473.20	13754.75
14	18		264”(6706mm)	TARA-54S4-WKM	PG4		12733.98	14048.92
14	20		270”(6858mm)	TARA-54T0-WKM	PG4		12995.00	14343.38
8	14	60”(1524mm)	186”(4724mm)	TARA-60J6-WKM	PG4		\$ 10309.95	\$ 11297.44
8	14		192”(4877mm)	TARA-60K2-WKM	PG4		10592.67	11616.05
8	14		198”(5029mm)	TARA-60K8-WKM	PG4		10875.67	11934.99
14	14		204”(5182mm)	TARA-60L4-WKM	PG4		11158.95	12254.28
14	14		210”(5334mm)	TARA-60M0-WKM	PG4		11442.50	12573.90
14	14		216”(5486mm)	TARA-60M6-WKM	PG4		11726.33	12893.85
14	16		222”(5639mm)	TARA-60N2-WKM	PG4		12010.43	13214.15
14	16		228”(5791mm)	TARA-60N8-WKM	PG4		12294.81	13534.78
14	16		234”(5944mm)	TARA-60P4-WKM	PG4		12579.47	13855.75
14	16		240”(6096mm)	TARA-60Q0-WKM	PG4		12864.40	14177.05
14	16		246”(6248mm)	TARA-60Q6-WKM	PG4		13149.61	14498.69
14	16		252”(6401mm)	TARA-60R2-WKM	PG4		13435.10	14820.67
14	18		258”(6553mm)	TARA-60R8-WKM	PG4		13720.86	15142.99
14	18		264”(6706mm)	TARA-60S4-WKM	PG4		14006.90	15465.64
14	20		270”(6858mm)	TARA-60T0-WKM	PG4		14293.21	15788.63

*Recommended seating capacity based upon 27”(686mm) per chair.

Planes Conference Table Tops for use with Column Base

EXAMPLE: Planes, Rectangle, 48" x 120", Wood, Edgeband, Standard Core, Center Double-Sided 12 Outlet Cutout, Column Base.

TA RA - 48 C0 - W K S Q B N N N

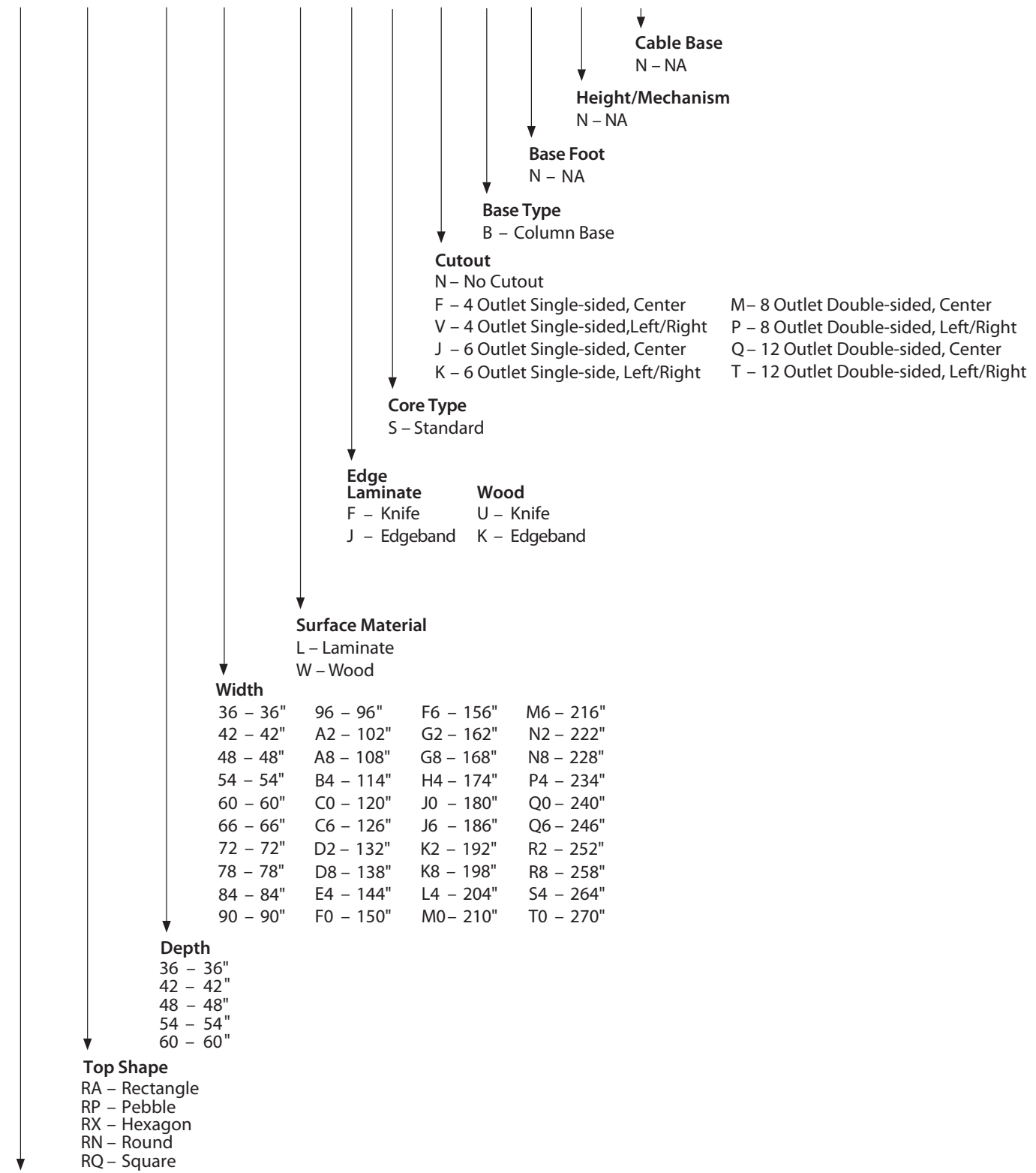

Planes Component Specification Overview

Conference Table with Column Base

Planes Conference Top(s), Column Base(s), and J-Channel(s) are separately specified. See below for required component specification.

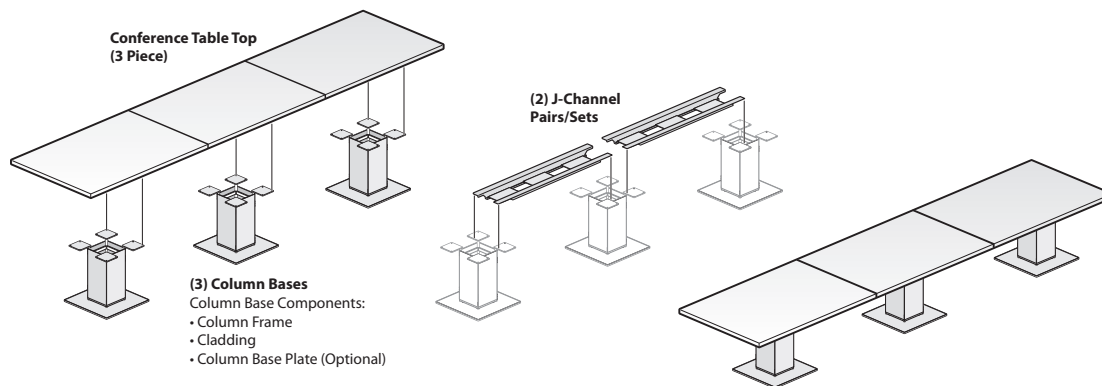

1 Conference Top

- The number of tops depend on the width of the conference table. Top options include a 1-piece top, 2-piece top or 3-piece top.

Column Base

Each Column Base requires separately specified components: **Column Frame, Column Base Plate, and Cladding.**

2 Column Frame

- Column Frames are square and are available in two sizes, 9"(229mm) & 12"(305mm) square, and three heights, 20"(508mm) lounge height, 28"(711mm) seated height and 40"(1016mm) standing height.
 - The table top width and the number of pieces dictate the quantity of column frame(s). **Refer to Matrix-A for details.**
 - The table top depth dictates the column frame size, 9"(229mm) or 12"(305mm) square. **Refer to Matrix-B for details.**

3 Column Base Plate

- Round or Square Column Base Plates are available in four sizes: 21"(533mm), 24"(610mm), 27"(686mm) and 30"(762mm).
 - The column base plate size is specific to the column frame size of 9"(229mm) or 12"(305mm); specify accordingly.
 - The column frame width and the table top depth dictate the size of the column base plate. **Refer to Matrix-B for details.**

4 Cladding

- Round or Flat Cladding is available in two widths, 9"(229mm) & 12"(305mm), and three heights, 20"(508mm) lounge height, 28"(711mm) seated height and 40"(1016mm) standing height. (Exception: Round cladding is not available 40" high)
 - Cladding is specified as one single piece per catalog number. A quantity of (4) pieces are required per each Column Frame.
 - Note: All round or flat, or a combination of round and flat cladding may be used on a column frame.
 - Specify cladding to match the column frame width and height.

5 J-Channel

- Provides wire management and the required support below the Conference Table Top.
 - J-Channel is specified as one pair per catalog number. A pair of J-Channels are used between each column base.
 - The table top width and column size dictate the number of pairs and length of J-Channel. **Refer to Matrix-A for details.**

J-Channel Tray - Optional

- J-Channel Trays are optional and provide additional wire management between columns; lays in J-Channels.
 - Specify J-Channel Tray width to match Column Frame size.
 - The J-Channel length dictates the maximum number of J-Channel Trays. **Refer to Matrix A for details.**

Planes Component Specification Overview

Conference Table with Column Base

MATRIX - A

Column Frame Quantity & J Channel Quantity and Size - Specification Matrix							
Table Width	Number of Pieces in Top	Number of Column Frames	Number of Pairs of J Channel	9"(229mm) x 9"(229mm) Column Frame		12"(305mm) x 12"(305mm) Column Frame	
				J Channel Length	# of Trays (Maximum)	J Channel Length	# of Trays (Maximum)
96"(2438mm)	1	2	1	29"(737mm)	1	26"(660mm)	1
102"(2591mm)	1	2	1	35"(889mm)	1	32"(813mm)	1
108"(2743mm)	1	2	1	41"(1041mm)	2	38"(965mm)	2
114"(2896mm)	1	2	1	47"(1194mm)	2	44"(1118mm)	2
120"(3048mm)	1	2	1	53"(1346mm)	3	50"(1270mm)	2
126"(3200mm)	2	2	1	59"(1499mm)	3	56"(1422mm)	3
132"(3353mm)	2	2	1	65"(1651mm)	3	62"(1575mm)	3
138"(3505mm)	2	2	1	71"(1803mm)	4	68"(1727mm)	4
144"(3658mm)	2	2	1	77"(1956mm)	4	74"(1880mm)	4
150"(3810mm)	2	2	1	83"(2108mm)	5	80"(2032mm)	5
156"(3962mm)	2	2	1	89"(2261mm)	5	86"(2184mm)	5
162"(4115mm)	2	2	1	95"(2413mm)	6	92"(2337mm)	5
168"(4267mm)	2	2	1	101"(2565mm)	6	98"(2489mm)	6
174"(4420mm)	2	3	2	50"(1270mm)	2	47"(1194mm)	2
180"(4572mm)	2	3	2	53"(1346mm)	3	50"(1270mm)	2
186"(4724mm)	3	3	2	56"(1422mm)	3	53"(1346mm)	3
192"(4877mm)	3	3	2	59"(1499mm)	3	56"(1422mm)	3
198"(5029mm)	3	3	2	62"(1575mm)	3	59"(1499mm)	3
204"(5182mm)	3	3	2	65"(1651mm)	3	62"(1575mm)	3
210"(5334mm)	3	3	2	68"(1727mm)	4	65"(1651mm)	3
216"(5486mm)	3	3	2	71"(1803mm)	4	68"(1727mm)	4
222"(5639mm)	3	3	2	74"(1880mm)	4	71"(1803mm)	4
228"(5791mm)	3	3	2	77"(1956mm)	4	74"(1880mm)	4
234"(5944mm)	3	3	2	80"(2032mm)	5	77"(1956mm)	4
240"(6096mm)	3	3	2	83"(2108mm)	5	80"(2032mm)	5
246"(6248mm)	3	3	2	86"(2184mm)	5	83"(2108mm)	5
252"(6401mm)	3	3	2	89"(2261mm)	5	86"(2184mm)	5
258"(6553mm)	3	3	2	92"(2337mm)	5	89"(2261mm)	5
264"(6706mm)	3	3	2	92"(2337mm)	6	92"(2337mm)	5
270"(6858mm)	3	3	2	98"(2489mm)	6	95"(2413mm)	6

MATRIX - B

Column Frame Size & Column Base Plate Size - Specification Matrix					
Table Depth	9"(229mm) x 9"(229mm) Column Frame		12"(305mm) x 12"(305mm) Column Frame		
	21"(533mm) Base Plate (Round or Square)	24"(610mm) Base Plate (Round or Square)	24"(610mm) Base Plate (Round or Square)	27"(686mm) Base Plate (Round or Square)	30"(762mm) Base Plate (Round or Square)
36"(914mm)	✓	✓	✓	✓	✓
42"(1067mm)		✓	✓	✓	✓
48"(1219mm)				✓	✓
54"(1372mm)				✓ (Square only)	✓
60"(1524mm)				✓ (Square only)	✓

Planes Conference Table Top — Round, Square and Pebble (for use with Column Base)

Laminate or Wood



TARN

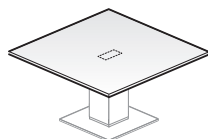

TARQ



TARP

Features

- Includes 1 3/16"(30mm) thick top.
- Laminate top with 3mm edgeband or knife, based upon shape.
- Wood veneer top with wood edgeband, or knife edge.
- Top available in standard core.
- **Requires separately specified Column Base.**
- Optional power modules are separately specified.
- Depth and width shown in nominal dimensions.

Specification Tips

- Conference Top requires separately specified components for Column Base:
 - Column Frame
 - Column Base Plate
 - Cladding (4) pieces per each Column Frame
- Cutouts are optional. If specified they are factory installed.
- Each cutout requires a separately specified flip top unit electrical module or a select workware interface module (see workware price list).
- Separately specified Planes grommets are available for field installation.
- For separately specified required components refer to the **Component Specification Overview** located in the front of the price list; see Planes Conference Table Tops (for use with Column Base).

To Order, Specify:

1) Product number, including;

1 Surface Options:

L Laminate

W Wood

2 Edge Options:

Laminate:

J Edgeband

F Knife

Wood:

K Wood Edgeband

U Knife

3 Cutout Options:

N No Cutout

F Center, Single-Sided/4 outlets, add \$33.13 list

J Center, Single-Sided/6 outlets, add \$33.13 list

M Center, Double-Sided/8 outlets, add \$33.13 list

Q Center, Double-Sided/12 outlets, add \$33.13 list

2) Laminate surface color or wood finish color.

3) Edgeband trim color (laminate only).

No. of Pieces	Seating Capacity*	Depth	Width	Number ① ② ③	Laminate A		Laminate B		Wood Group A		Wood Group B	
					J	F	J	F	K	U	K	U
Round												
1	4	36"(914mm)	36"(914mm)	TARN-3636-■ ■ S ■ BNNN	\$ 384.12	\$ 604.28	\$ 449.96	\$ 670.12	\$ 738.93	\$ 961.25	\$ 762.87	\$1005.06
1	4	42"(1067mm)	42"(1067mm)	TARN-4242-■ ■ S ■ BNNN	540.43	790.35	623.30	873.22	964.56	1285.70	1002.29	1352.65
1	4	48"(1219mm)	48"(1219mm)	TARN-4848-■ ■ S ■ BNNN	719.68	999.36	822.20	1101.88	1221.21	1660.80	1274.63	1754.50
1	8	54"(1372mm)	54"(1372mm)	TARN-5454-■ ■ S ■ BNNN	921.87	1231.31	1046.66	1356.10	1810.66	2504.54	1881.67	2628.68
1	8	60"(1524mm)	60"(1524mm)	TARN-6060-■ ■ S ■ BNNN	1147.00	1486.20	1296.68	1635.88	2193.08	3076.30	2283.58	3234.45
Square												
1	4	36"(914mm)	36"(914mm)	TARQ-3636-■ ■ S ■ BNNN	\$ 382.68	\$ 595.64	\$ 448.52	\$ 661.48	\$ 738.93	\$ 961.25	\$ 762.87	\$1005.06
1	4	42"(1067mm)	42"(1067mm)	TARQ-4242-■ ■ S ■ BNNN	538.75	780.27	621.62	863.14	964.56	1285.70	1002.29	1352.65
1	4	48"(1219mm)	48"(1219mm)	TARQ-4848-■ ■ S ■ BNNN	717.76	987.84	820.28	1090.36	1221.21	1660.80	1274.63	1754.50
1	8	54"(1372mm)	54"(1372mm)	TARQ-5454-■ ■ S ■ BNNN	919.71	1218.35	1044.50	1343.14	1810.66	2504.54	1881.67	2628.68
1	8	60"(1524mm)	60"(1524mm)	TARQ-6060-■ ■ S ■ BNNN	1144.60	1471.80	1294.28	1621.48	2193.08	3076.30	2283.58	3234.45
Pebble												
1	4	36"(914mm)	36"(914mm)	TARP-3636-■ ■ S ■ BNNN	\$ 384.12	\$ 604.28	\$ 449.96	\$ 670.12	\$ 738.93	\$ 961.25	\$ 762.87	\$1005.06
1	4	42"(1067mm)	42"(1067mm)	TARP-4242-■ ■ S ■ BNNN	540.43	790.35	623.30	873.22	964.56	1285.70	1002.29	1352.65
1	4	48"(1219mm)	48"(1219mm)	TARP-4848-■ ■ S ■ BNNN	719.68	999.36	822.20	1101.88	1221.21	1660.80	1274.63	1754.50
1	8	54"(1372mm)	54"(1372mm)	TARP-5454-■ ■ S ■ BNNN	921.87	1231.31	1046.66	1356.10	1810.66	2504.54	1881.67	2628.68
1	8	60"(1524mm)	60"(1524mm)	TARP-6060-■ ■ S ■ BNNN	1147.00	1486.20	1296.68	1635.88	2193.08	3076.30	2283.58	3234.45

*Recommended seating capacity based upon 27"(687mm) per chair.

This page intentionally blank

Planes Conference Table Top — Rectangle (for use with Column Base)

Laminate or Wood

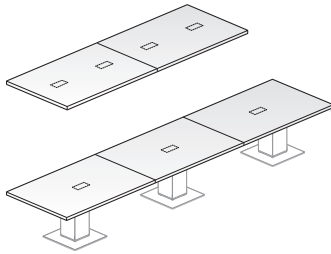

TARA

Features

- Includes 1 3/16" (30mm) thick top.
- Laminate top with 3mm edgeband or knife edge, or wood veneer top with 3mm wood edgeband or knife edge on user edges. Multiple piece tops are 1mm edgeband at the seams.
- Table top seams are 1mm edgeband.
- **Requires separately specified Column Base and J Channels.**
- Optional power modules are separately specified.
- Depth and width shown in nominal dimensions.

Specification Tips

- Multiple piece conference tops have equal sized pieces and are shipped unassembled.
- Conference Top requires separately specified components for Column Base:
 - Column Frame
 - Column Base Plate
 - Cladding (4) pieces per each Column Frame
- Conference Top requires separately specified J Channels for support and load purposes.
- Cutouts are optional. If specified they are factory installed.
- Each cutout requires a separately specified flip top unit electrical module or a select workware interface module (see workware price list).
- Separately specified Planes grommets are available for field installation.
- For separately specified required components refer to the **Component Specification Overview** located in the front of the price list; see Planes Conference Table Tops (for use with Column Base).

3 Cutout Options

Cutout	1 Piece	2 Piece	3 Piece
F	\$33.13	\$ 66.26	\$ 99.39
V	\$66.26	\$132.52	\$198.78
J	\$33.13	\$ 66.26	\$ 99.39
K	\$66.26	\$132.52	\$198.78
M	\$33.13	\$ 66.26	\$ 99.39
P	\$66.26	\$132.52	\$198.78
Q	\$33.13	\$ 66.26	\$ 99.39
T	\$66.26	\$132.52	\$198.78

To Order, Specify:

1) Product number, including;

1 Surface Options:

- L** Laminate
- W** Wood

2 Edge Options:

Laminate:

- J** Edgeband
- F** Knife

Wood:

- K** Wood Edgeband
- U** Knife

3 Cutout Options:

- N** No Cutout
- F** Center, Single-Sided/4 outlets, see chart for upcharge
- V** Left/Right, Single-Sided/4 outlets, see chart for upcharge
- J** Center, Single-Sided/6 outlets, see chart for upcharge
- K** Left/Right, Single-Sided/6 outlets, see chart for upcharge
- M** Center, Double-Sided/8 outlets, see chart for upcharge
- P** Left/Right, Double-Sided/8 outlets, see chart for upcharge
- Q** Center, Double-Sided/12 outlets, see chart for upcharge
- T** Left/Right, Double-Sided/12 outlets, see chart for upcharge

2) Laminate surface color or wood finish color.

3) Edgeband trim color (laminate only).

Planes Conference Table Top — Rectangle (for use with Column Base)

Laminate or Wood

No. of Pieces	Seating Capacity*	Depth	Width	Number ① ② ③	Laminate A		Laminate B		Wood Group A		Wood Group B	
					J	F	J	F	K	U	K	U
1	8	42"(1067mm)	96"(2438mm)	TARA-4296-■ ■ ■ S ■ BNNN	\$1274.12	\$1638.64	\$1423.09	\$1787.61	\$2051.63	\$ 2587.69	\$ 2335.13	\$ 2949.15
1	8		102"(2591mm)	TARA-42A2-■ ■ ■ S ■ BNNN	1357.70	1736.26	1515.98	1894.54	2184.90	2761.33	2492.64	3153.58
1	10		108"(2743mm)	TARA-42A8-■ ■ ■ S ■ BNNN	1441.28	1833.88	1608.87	2001.47	2318.43	2936.80	2650.47	3360.17
1	10		114"(2896mm)	TARA-42B4-■ ■ ■ S ■ BNNN	1524.86	1931.50	1701.76	2108.40	2452.24	3114.12	2808.63	3568.92
1	10		120"(3048mm)	TARA-42C0-■ ■ ■ S ■ BNNN	1608.44	2029.12	1794.65	2215.33	2586.31	3293.27	2967.11	3779.83
2	10		126"(3200mm)	TARA-42C6-■ ■ ■ S ■ BNNN	2221.68	2683.26	2417.20	2878.78	3944.74	4857.22	4350.02	5375.85
2	10		132"(3353mm)	TARA-42D2-■ ■ ■ S ■ BNNN	2329.01	2804.63	2533.84	3009.46	4103.10	5059.06	4532.90	5610.08
2	12		138"(3505mm)	TARA-42D8-■ ■ ■ S ■ BNNN	2436.34	2926.00	2650.48	3140.14	4261.72	5262.73	4716.10	5846.47
2	12		144"(3658mm)	TARA-42E4-■ ■ ■ S ■ BNNN	2543.67	3047.37	2767.12	3270.82	4420.62	5468.25	4899.63	6085.02
2	12		150"(3810mm)	TARA-42F0-■ ■ ■ S ■ BNNN	2651.00	3168.74	2883.76	3401.50	4579.78	5675.61	5083.48	6325.73
2	12		156"(3962mm)	TARA-42F6-■ ■ ■ S ■ BNNN	2758.33	3290.11	3000.40	3532.18	4739.20	5884.80	5267.66	6568.60
2	14		162"(4115mm)	TARA-42G2-■ ■ ■ S ■ BNNN	2865.66	3411.48	3117.04	3662.86	4898.90	6095.84	5452.16	6813.63
2	14		168"(4267mm)	TARA-42G8-■ ■ ■ S ■ BNNN	2972.99	3532.85	3233.68	3793.54	5058.86	6308.72	5636.98	7060.82
2	14		174"(4420mm)	TARA-42H4-■ ■ ■ S ■ BNNN	3080.32	3654.22	3350.32	3924.22	5219.09	6523.44	5822.13	7310.17
2	14		180"(4572mm)	TARA-42J0-■ ■ ■ S ■ BNNN	3187.65	3775.59	3466.96	4054.90	5379.59	6740.00	6007.60	7561.68
3	14		186"(4724mm)	TARA-42J6-■ ■ ■ S ■ BNNN	3306.87	3943.19	3595.49	4231.81	5676.62	6972.68	6329.66	7829.63
3	16		192"(4877mm)	TARA-42K2-■ ■ ■ S ■ BNNN	3414.20	4064.56	3712.13	4362.49	5837.65	7185.80	6515.78	8078.34
3	16		198"(5029mm)	TARA-42K8-■ ■ ■ S ■ BNNN	3521.53	4185.93	3828.77	4493.17	5998.95	7400.76	6702.22	8329.21
3	16		204"(5182mm)	TARA-42L4-■ ■ ■ S ■ BNNN	3628.86	4307.30	3945.41	4623.85	6160.52	7617.56	6888.99	8582.24
3	16		210"(5334mm)	TARA-42M0-■ ■ ■ S ■ BNNN	3736.19	4428.67	4062.05	4754.53	6322.36	7836.20	7076.08	8837.43
3	18		216"(5486mm)	TARA-42M6-■ ■ ■ S ■ BNNN	3843.52	4550.04	4178.69	4885.21	6484.47	8056.68	7263.50	9094.78
3	18		222"(5639mm)	TARA-42N2-■ ■ ■ S ■ BNNN	3950.85	4671.41	4295.33	5015.89	6646.84	8279.00	7451.24	9354.29
3	18		228"(5791mm)	TARA-42N8-■ ■ ■ S ■ BNNN	4058.18	4792.78	4411.97	5146.57	6809.48	8503.16	7639.30	9615.96
3	18		234"(5944mm)	TARA-42P4-■ ■ ■ S ■ BNNN	4165.51	4914.15	4528.61	5277.25	6972.39	8729.16	7827.69	9879.79
3	18		240"(6096mm)	TARA-42Q0-■ ■ ■ S ■ BNNN	4272.84	5035.52	4645.25	5407.93	7135.57	8957.01	8016.40	10145.78
3	20		246"(6248mm)	TARA-42Q6-■ ■ ■ S ■ BNNN	4380.17	5156.89	4761.89	5538.61	7299.01	9186.69	8205.44	10413.93
3	20		252"(6401mm)	TARA-42R2-■ ■ ■ S ■ BNNN	4487.50	5278.26	4878.53	5669.29	7462.73	9418.21	8394.80	10684.24
3	20		258"(6553mm)	TARA-42R8-■ ■ ■ S ■ BNNN	4594.83	5399.63	4995.17	5799.97	7626.71	9651.57	8584.48	10956.71
3	20		264"(6706mm)	TARA-42S4-■ ■ ■ S ■ BNNN	4702.16	5521.00	5111.81	5930.65	7790.96	9886.78	8774.49	11231.34
3	22		270"(6858mm)	TARA-42T0-■ ■ ■ S ■ BNNN	4809.49	5642.37	5228.45	6061.33	7955.47	10123.82	8964.82	11508.13
1	8	48"(1219mm)	96"(2438mm)	TARA-4896-■ ■ ■ S ■ BNNN	\$1461.92	\$1840.48	\$1632.17	\$2010.73	\$2336.58	\$ 2894.13	\$ 2671.36	\$ 3310.27
1	8		102"(2591mm)	TARA-48A2-■ ■ ■ S ■ BNNN	1557.08	1949.68	1737.97	2130.57	2487.19	3085.90	2849.32	3536.07
1	10		108"(2743mm)	TARA-48A8-■ ■ ■ S ■ BNNN	1652.24	2058.88	1843.77	2250.41	2638.06	3279.50	3027.61	3764.03
1	10		114"(2896mm)	TARA-48B4-■ ■ ■ S ■ BNNN	1747.40	2168.08	1949.57	2370.25	2789.21	3474.95	3206.22	3994.15
1	10		120"(3048mm)	TARA-48C0-■ ■ ■ S ■ BNNN	1842.56	2277.28	2055.37	2490.09	2940.63	3672.23	3385.15	4226.43
2	10		126"(3200mm)	TARA-48C6-■ ■ ■ S ■ BNNN	2543.38	3019.00	2766.83	3242.45	4435.17	5503.69	4907.27	6093.20
2	10		132"(3353mm)	TARA-48D2-■ ■ ■ S ■ BNNN	2662.29	3151.95	2896.38	3386.04	4610.87	5723.66	5110.60	6348.80
2	12		138"(3505mm)	TARA-48D8-■ ■ ■ S ■ BNNN	2781.20	3284.90	3025.93	3529.63	4786.83	5945.46	5314.26	6606.56
2	12		144"(3658mm)	TARA-48E4-■ ■ ■ S ■ BNNN	2900.11	3417.85	3155.48	3673.22	4963.07	6169.11	5518.24	6866.48
2	12		150"(3810mm)	TARA-48F0-■ ■ ■ S ■ BNNN	3019.02	3550.80	3285.03	3816.81	5139.57	6394.60	5722.54	7128.56
2	12		156"(3962mm)	TARA-48F6-■ ■ ■ S ■ BNNN	3137.93	3683.75	3414.58	3960.40	5316.35	6621.93	5927.17	7392.80
2	14		162"(4115mm)	TARA-48G2-■ ■ ■ S ■ BNNN	3256.84	3816.70	3544.13	4103.99	5493.38	6851.10	6132.12	7659.20
2	14		168"(4267mm)	TARA-48G8-■ ■ ■ S ■ BNNN	3375.75	3949.65	3673.68	4247.58	5670.69	7082.10	6337.40	7927.76
2	14		174"(4420mm)	TARA-48H4-■ ■ ■ S ■ BNNN	3494.66	4082.60	3803.23	4391.17	5848.27	7314.95	6543.00	8198.48
2	14		180"(4572mm)	TARA-48J0-■ ■ ■ S ■ BNNN	3613.57	4215.55	3932.78	4534.76	6026.11	7549.64	6748.92	8471.36
3	14		186"(4724mm)	TARA-48J6-■ ■ ■ S ■ BNNN	3744.37	4394.73	4074.22	4724.58	6446.18	7800.45	7197.13	8760.68
3	16		192"(4877mm)	TARA-48K2-■ ■ ■ S ■ BNNN	3863.28	4527.68	4203.77	4868.17	6624.56	8031.70	7403.70	9030.76
3	16		198"(5029mm)	TARA-48K8-■ ■ ■ S ■ BNNN	3982.19	4660.63	4333.32	5011.76	6803.20	8264.79	7610.60	9303.00
3	16		204"(5182mm)	TARA-48L4-■ ■ ■ S ■ BNNN	4101.10	4793.58	4462.87	5155.35	6982.12	8499.72	7817.82	9577.40
3	16		210"(5334mm)	TARA-48M0-■ ■ ■ S ■ BNNN	4220.01	4926.53	4592.42	5298.94	7161.30	8736.49	8025.36	9853.96
3	18		216"(5486mm)	TARA-48M6-■ ■ ■ S ■ BNNN	4338.92	5059.48	4721.97	5442.53	7340.75	8975.10	8233.23	10132.68
3	18		222"(5639mm)	TARA-48N2-■ ■ ■ S ■ BNNN	4457.83	5192.43	4851.52	5586.12	7520.47	9215.55	8441.42	10413.56
3	18		228"(5791mm)	TARA-48N8-■ ■ ■ S ■ BNNN	4576.74	5325.38	4981.07	5729.71	7700.45	9457.85	8649.94	10696.60
3	18		234"(5944mm)	TARA-48P4-■ ■ ■ S ■ BNNN	4695.65	5458.33	5110.62	5873.30	7880.71	9701.98	8858.78	10981.80
3	18		240"(6096mm)	TARA-48Q0-■ ■ ■ S ■ BNNN	4814.56	5591.28	5240.17	6016.89	8061.23	9947.95	9067.94	11269.16
3	20		246"(6248mm)	TARA-48Q6-■ ■ ■ S ■ BNNN	4933.47	5724.23	5369.72	6160.48	8242.02	10195.76	9277.43	11558.68
3	20		252"(6401mm)	TARA-48R2-■ ■ ■ S ■ BNNN	5052.38	5857.18	5499.27	6304.07	8423.07	10445.42	9487.24	11850.36
3	20		258"(6553mm)	TARA-48R8-■ ■ ■ S ■ BNNN	5171.29	5990.13	5628.82	6447.66	8604.40	10696.91	9697.38	12144.20
3	20		264"(6706mm)	TARA-48S4-■ ■ ■ S ■ BNNN	5290.20	6123.08	5758.37	6591.25	8785.99	10950.24	9907.84	12440.20
3	22		270"(6858mm)	TARA-48T0-■ ■ ■ S ■ BNNN	5409.11	6256.03	5887.92	6734.84	8967.85	11205.42	10118.62	12738.36

*Recommended seating capacity based upon 27"(687mm) per chair.

Planes Conference Table Top — Rectangle (for use with Column Base)

Laminate or Wood

No. of Pieces	Seating Capacity*	Depth	Width	Number ① ② ③	Laminate A		Laminate B		Wood Group A		Wood Group B	
					J	F	J	F	K	U	K	U
1	10	54"(1372mm)	96"(2438mm)	TARA-5496-■ ■ ■ S ■ BNNN	\$1649.72	\$2042.32	\$1841.25	\$2233.85	\$ 3145.82	\$ 3840.68	\$ 3531.89	\$ 4311.50
1	10		102"(2591mm)	TARA-54A2-■ ■ ■ S ■ BNNN	1756.46	2163.10	1959.96	2366.60	3313.77	4050.58	3730.30	4558.67
1	12		108"(2743mm)	TARA-54A8-■ ■ ■ S ■ BNNN	1863.20	2283.88	2078.67	2499.35	3482.00	4262.31	3929.04	4808.00
1	12		114"(2896mm)	TARA-54B4-■ ■ ■ S ■ BNNN	1969.94	2404.66	2197.38	2632.10	3650.49	4475.89	4128.10	5059.49
1	12		120"(3048mm)	TARA-54C0-■ ■ ■ S ■ BNNN	2076.68	2525.44	2316.09	2764.85	3819.24	4691.31	4327.49	5313.14
2	12		126"(3200mm)	TARA-54C6-■ ■ ■ S ■ BNNN	2865.08	3354.74	3116.46	3606.12	5449.89	6790.27	5988.82	7450.66
2	12		132"(3353mm)	TARA-54D2-■ ■ ■ S ■ BNNN	2995.57	3499.27	3258.92	3762.62	5642.93	7028.37	6212.60	7727.63
2	14		138"(3505mm)	TARA-54D8-■ ■ ■ S ■ BNNN	3126.06	3643.80	3401.38	3919.12	5836.25	7268.31	6436.71	8006.76
2	14		144"(3658mm)	TARA-54E4-■ ■ ■ S ■ BNNN	3256.55	3788.33	3543.84	4075.62	6029.82	7510.08	6661.14	8288.05
2	14		150"(3810mm)	TARA-54F0-■ ■ ■ S ■ BNNN	3387.04	3932.86	3686.30	4232.12	6223.67	7753.70	6885.90	8571.50
2	14		156"(3962mm)	TARA-54F6-■ ■ ■ S ■ BNNN	3517.53	4077.39	3828.76	4388.62	6417.79	7999.16	7110.98	8857.11
2	16		162"(4115mm)	TARA-54G2-■ ■ ■ S ■ BNNN	3648.02	4221.92	3971.22	4545.12	6612.17	8246.46	7336.38	9144.88
2	16		168"(4267mm)	TARA-54G8-■ ■ ■ S ■ BNNN	3778.51	4366.45	4113.68	4701.62	6806.82	8495.60	7562.11	9434.81
2	16		174"(4420mm)	TARA-54H4-■ ■ ■ S ■ BNNN	3909.00	4510.98	4256.14	4858.12	7001.74	8746.58	7788.16	9726.90
2	16		180"(4572mm)	TARA-54J0-■ ■ ■ S ■ BNNN	4039.49	4655.51	4398.60	5014.62	7196.93	8999.39	8014.54	10021.15
3	16		186"(4724mm)	TARA-54J6-■ ■ ■ S ■ BNNN	4113.47	4846.27	4484.55	5217.35	7740.04	9268.33	8588.90	10331.84
3	18		192"(4877mm)	TARA-54K2-■ ■ ■ S ■ BNNN	4243.96	4990.80	4627.01	5373.85	7935.76	9517.71	8815.92	10623.29
3	18		198"(5029mm)	TARA-54K8-■ ■ ■ S ■ BNNN	4374.45	5135.33	4769.47	5530.35	8131.75	9768.93	9043.27	10916.90
3	18		204"(5182mm)	TARA-54L4-■ ■ ■ S ■ BNNN	4504.94	5279.86	4911.93	5686.85	8328.01	10022.00	9270.94	11212.67
3	18		210"(5334mm)	TARA-54M0-■ ■ ■ S ■ BNNN	4635.43	5424.39	5054.39	5843.35	8524.54	10276.90	9498.94	11510.60
3	20		216"(5486mm)	TARA-54M6-■ ■ ■ S ■ BNNN	4765.92	5568.92	5196.85	5999.85	8721.33	10533.64	9727.26	11810.69
3	20		222"(5639mm)	TARA-54N2-■ ■ ■ S ■ BNNN	4896.41	5713.45	5339.31	6156.35	8918.39	10792.22	9955.90	12112.94
3	20		228"(5791mm)	TARA-54N8-■ ■ ■ S ■ BNNN	5026.90	5857.98	5481.77	6312.85	9115.72	11052.64	10184.87	12417.35
3	20		234"(5944mm)	TARA-54P4-■ ■ ■ S ■ BNNN	5157.39	6002.51	5624.23	6469.35	9313.32	11314.90	10414.16	12723.92
3	20		240"(6096mm)	TARA-54Q0-■ ■ ■ S ■ BNNN	5287.88	6147.04	5766.69	6625.85	9511.18	11579.01	10643.78	13032.65
3	22		246"(6248mm)	TARA-54Q6-■ ■ ■ S ■ BNNN	5418.37	6291.57	5909.15	6782.35	9709.32	11844.95	10873.72	13343.54
3	22		252"(6401mm)	TARA-54R2-■ ■ ■ S ■ BNNN	5548.86	6436.10	6051.61	6938.85	9907.72	12112.73	11103.98	13656.59
3	22		258"(6553mm)	TARA-54R8-■ ■ ■ S ■ BNNN	5679.35	6580.63	6194.07	7095.35	10106.39	12382.35	11334.57	13971.80
3	22		264"(6706mm)	TARA-54S4-■ ■ ■ S ■ BNNN	5809.84	6725.16	6336.53	7251.85	10305.32	12653.82	11565.48	14289.17
3	24		270"(6858mm)	TARA-54T0-■ ■ ■ S ■ BNNN	5940.33	6869.69	6478.99	7408.35	10504.53	12927.12	11796.72	14608.70
1	10	60"(1524mm)	96"(2438mm)	TARA-6096-■ ■ ■ S ■ BNNN	\$1837.52	\$2244.16	\$2050.33	\$2456.97	\$ 3487.75	\$ 4208.41	\$ 3925.11	\$ 4733.91
1	10		102"(2591mm)	TARA-60A2-■ ■ ■ S ■ BNNN	1955.84	2376.52	2181.95	2602.63	3673.05	4436.44	4143.98	5002.45
1	12		108"(2743mm)	TARA-60A8-■ ■ ■ S ■ BNNN	2074.16	2508.88	2313.57	2748.29	3858.62	4666.31	4363.17	5273.15
1	12		114"(2896mm)	TARA-60B4-■ ■ ■ S ■ BNNN	2192.48	2641.24	2445.19	2893.95	4044.45	4898.01	4582.68	5546.01
1	12		120"(3048mm)	TARA-60C0-■ ■ ■ S ■ BNNN	2310.80	2773.60	2576.81	3039.61	4230.55	5131.56	4802.52	5821.03
2	12		126"(3200mm)	TARA-60C6-■ ■ ■ S ■ BNNN	3186.78	3690.48	3466.09	3969.79	5997.30	7498.03	6603.06	8229.30
2	12		132"(3353mm)	TARA-60D2-■ ■ ■ S ■ BNNN	3328.85	3846.59	3621.46	4139.20	6207.69	7754.26	6847.30	8527.64
2	14		138"(3505mm)	TARA-60D8-■ ■ ■ S ■ BNNN	3470.92	4002.70	3776.83	4308.61	6418.35	8012.33	7091.86	8828.14
2	14		144"(3658mm)	TARA-60E4-■ ■ ■ S ■ BNNN	3612.99	4158.81	3932.20	4478.02	6629.27	8272.24	7336.74	9130.80
2	14		150"(3810mm)	TARA-60F0-■ ■ ■ S ■ BNNN	3755.06	4314.92	4087.57	4647.43	6840.46	8533.98	7581.95	9435.62
2	14		156"(3962mm)	TARA-60F6-■ ■ ■ S ■ BNNN	3897.13	4471.03	4242.94	4816.84	7051.92	8797.57	7827.48	9742.60
2	16		162"(4115mm)	TARA-60G2-■ ■ ■ S ■ BNNN	4039.20	4627.14	4398.31	4986.25	7263.65	9063.00	8073.34	10051.74
2	16		168"(4267mm)	TARA-60G8-■ ■ ■ S ■ BNNN	4181.27	4783.25	4553.68	5155.66	7475.64	9330.27	8319.52	10363.04
2	16		174"(4420mm)	TARA-60H4-■ ■ ■ S ■ BNNN	4323.34	4939.36	4709.05	5325.07	7687.90	9599.38	8566.02	10676.50
2	16		180"(4572mm)	TARA-60J0-■ ■ ■ S ■ BNNN	4465.41	5095.47	4864.42	5494.48	7900.43	9870.33	8812.85	10992.12
3	16		186"(4724mm)	TARA-60J6-■ ■ ■ S ■ BNNN	4482.57	5297.81	4894.88	5710.12	8566.59	10157.40	9513.36	11324.18
3	18		192"(4877mm)	TARA-60K2-■ ■ ■ S ■ BNNN	4624.64	5453.92	5050.25	5879.53	8779.66	10424.91	9760.84	11637.00
3	18		198"(5029mm)	TARA-60K8-■ ■ ■ S ■ BNNN	4766.71	5610.03	5205.62	6048.94	8992.99	10694.26	10008.64	11951.98
3	18		204"(5182mm)	TARA-60L4-■ ■ ■ S ■ BNNN	4908.78	5766.14	5360.99	6218.35	9206.59	10965.45	10256.76	12269.12
3	18		210"(5334mm)	TARA-60M0-■ ■ ■ S ■ BNNN	5050.85	5922.25	5516.36	6387.76	9420.46	11238.48	10505.21	12588.42
3	20		216"(5486mm)	TARA-60M6-■ ■ ■ S ■ BNNN	5192.92	6078.36	5671.73	6557.17	9634.60	11513.35	10753.98	12909.88
3	20		222"(5639mm)	TARA-60N2-■ ■ ■ S ■ BNNN	5334.99	6234.47	5827.10	6726.58	9849.01	11790.06	11003.08	13233.50
3	20		228"(5791mm)	TARA-60N8-■ ■ ■ S ■ BNNN	5477.06	6390.58	5982.47	6895.99	10063.68	12068.62	11252.50	13559.28
3	20		234"(5944mm)	TARA-60P4-■ ■ ■ S ■ BNNN	5619.13	6546.69	6137.84	7065.40	10278.62	12349.01	11502.24	13887.22
3	20		240"(6096mm)	TARA-60Q0-■ ■ ■ S ■ BNNN	5761.20	6702.80	6293.21	7234.81	10493.83	12631.24	11752.31	14217.32
3	22		246"(6248mm)	TARA-60Q6-■ ■ ■ S ■ BNNN	5903.27	6858.91	6448.58	7404.22	10709.31	12915.31	12002.70	14549.58
3	22		252"(6401mm)	TARA-60R2-■ ■ ■ S ■ BNNN	6045.34	7015.02	6603.95	7573.63	10925.05	13201.23	12253.42	14884.00
3	22		258"(6553mm)	TARA-60R8-■ ■ ■ S ■ BNNN	6187.41	7171.13	6759.32	7743.04	11141.06	13488.98	12504.46	15220.58
3	22		264"(6706mm)	TARA-60S4-■ ■ ■ S ■ BNNN	6329.48	7327.24	6914.69	7912.45	11357.34	13778.57	12755.82	15559.32
3	24		270"(6858mm)	TARA-60T0-■ ■ ■ S ■ BNNN	6471.55	7483.35	7070.06	8081.86	11573.89	14070.01	13007.51	15900.22

*Recommended seating capacity based upon 27"(687mm) per chair.

This page intentionally blank

Planes Conference Table Top — Pebble (for use with Column Base)

Laminate or Wood

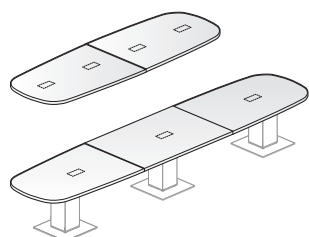

TARP

Features

- Includes 1 3/16" (30mm) thick top(s).
- Laminate top with 3mm edgeband or knife edge, or wood veneer top with 3mm wood edgeband or knife edge on user edges. Multiple piece tops are 1mm edgeband at the seams.
- Table top seams are 1mm edgeband.
- **Requires separately specified Column Base and J Channels.**
- Optional power modules are separately specified.
- Depth and width shown in nominal dimensions.

Specification Tips

- Multiple piece conference tops have equal sized pieces and are shipped unassembled.
- Conference Top requires separately specified components for Column Base:
 - Column Frame
 - Column Base Plate
 - Cladding (4) pieces per each Column Frame
- Conference Top requires separately specified J Channels for support and load purposes.
- Cutouts are optional. If specified they are factory installed.
- Each cutout requires a separately specified flip top unit electrical module or a select workware interface module (see workware price list).
- Separately specified Planes grommets are available for field installation.
- For separately specified required components refer to the **Component Specification Overview** located in the front of the price list; see Planes Conference Table Tops (for use with Column Base).

3 Cutout Options

Cutout	1 Piece	2 Piece	3 Piece
F	\$33.13	\$ 66.26	\$ 99.39
V	\$66.26	\$132.52	\$198.78
J	\$33.13	\$ 66.26	\$ 99.39
K	\$66.26	\$132.52	\$198.78
M	\$33.13	\$ 66.26	\$ 99.39
P	\$66.26	\$132.52	\$198.78
Q	\$33.13	\$ 66.26	\$ 99.39
T	\$66.26	\$132.52	\$198.78

To Order, Specify:

1) Product number, including;

1 Surface Options:

L Laminate

W Wood

2 Edge Options:

Laminate:

J Edgeband

F Knife

Wood:

K Wood Edgeband

U Knife

3 Cutout Options:

N No Cutout

F Center, Single-Sided/4 outlets, see chart for upcharge

V Left/Right, Single-Sided/4 outlets, see chart for upcharge

J Center, Single-Sided/6 outlets, see chart for upcharge

K Left/Right, Single-Sided/6 outlets, see chart for upcharge

M Center, Double-Sided/8 outlets, see chart for upcharge

P Left/Right, Double-Sided/8 outlets, see chart for upcharge

Q Center, Double-Sided/12 outlets, see chart for upcharge

T Left/Right, Double-Sided/12 outlets, see chart for upcharge

2) Laminate surface color or wood finish color.

3) Edgeband trim color (laminate only).

Planes Conference Table Top — Pebble (for use with Column Base)

Laminate or Wood

No. of Pieces	Seating Capacity*	Depth	Width	Number	①	②	③	Laminate A		Laminate B		Wood Group A		Wood Group B		
								J	F	J	F	K	U	K	U	
1	8	42"(1067mm)	96"(2438mm)	TARP-4296-	■	■	S	BNNN	\$1274.12	\$1638.64	\$1423.09	\$1787.61	\$2051.63	\$ 2587.69	\$ 2335.13	\$ 2949.15
1	8		102"(2591mm)	TARP-42A2-	■	■	S	BNNN	1357.70	1736.26	1515.98	1894.54	2184.90	2761.33	2492.64	3153.58
1	10		108"(2743mm)	TARP-42A8-	■	■	S	BNNN	1441.28	1833.88	1608.87	\$2001.47	2318.43	2936.80	2650.47	3360.17
1	10		114"(2896mm)	TARP-42B4-	■	■	S	BNNN	1524.86	1931.50	1701.76	2108.40	2452.24	3114.12	2808.63	3568.92
1	10		120"(3048mm)	TARP-42C0-	■	■	S	BNNN	1608.44	2029.12	1794.65	2215.33	2586.31	3293.27	2967.11	3779.83
2	10		126"(3200mm)	TARP-42C6-	■	■	S	BNNN	2221.68	2683.26	2417.20	2878.78	3944.74	4857.22	4350.02	5375.85
2	10		132"(3353mm)	TARP-42D2-	■	■	S	BNNN	2329.01	2804.63	2533.84	3009.46	4103.10	5059.06	4532.90	5610.08
2	12		138"(3505mm)	TARP-42D8-	■	■	S	BNNN	2436.34	2926.00	2650.48	3140.14	4261.72	5262.73	4716.10	5846.47
2	12		144"(3658mm)	TARP-42E4-	■	■	S	BNNN	2543.67	3047.37	2767.12	3270.82	4420.62	5468.25	4899.63	6085.02
2	12		150"(3810mm)	TARP-42F0-	■	■	S	BNNN	2651.00	3168.74	2883.76	3401.50	4579.78	5675.61	5083.48	6325.73
2	12		156"(3962mm)	TARP-42F6-	■	■	S	BNNN	2758.33	3290.11	3000.40	3532.18	4739.20	5884.80	5267.66	6568.60
2	14		162"(4115mm)	TARP-42G2-	■	■	S	BNNN	2865.66	3411.48	3117.04	3662.86	4898.90	6095.84	5452.16	6813.63
2	14		168"(4267mm)	TARP-42G8-	■	■	S	BNNN	2972.99	3532.85	3233.68	3793.54	5058.86	6308.72	5636.98	7060.82
2	14		174"(4420mm)	TARP-42H4-	■	■	S	BNNN	3080.32	3654.22	3350.32	3924.22	5219.09	6523.44	5822.13	7310.17
2	14		180"(4572mm)	TARP-42J0-	■	■	S	BNNN	3187.65	3775.59	3466.96	4054.90	5379.59	6740.00	6007.60	7561.68
3	14		186"(4724mm)	TARP-42J6-	■	■	S	BNNN	3306.87	3943.19	3595.49	4231.81	5676.62	6972.68	6329.66	7879.63
3	16		192"(4877mm)	TARP-42K2-	■	■	S	BNNN	3414.20	4064.56	3712.13	4362.49	5837.65	7185.80	6515.78	8078.34
3	16		198"(5029mm)	TARP-42K8-	■	■	S	BNNN	3521.53	4185.93	3828.77	4493.17	5998.95	7400.76	6702.22	8329.21
3	16		204"(5182mm)	TARP-42L4-	■	■	S	BNNN	3628.86	4307.30	3945.41	4623.85	6160.52	7617.56	6888.99	8582.24
3	16		210"(5334mm)	TARP-42M0-	■	■	S	BNNN	3736.19	4428.67	4062.05	4754.53	6322.36	7836.20	7076.08	8837.43
3	18		216"(5486mm)	TARP-42M6-	■	■	S	BNNN	3843.52	4550.04	4178.69	4885.21	6484.47	8056.68	7263.50	9094.78
3	18		222"(5639mm)	TARP-42N2-	■	■	S	BNNN	3950.85	4671.41	4295.33	5015.89	6646.84	8279.00	7451.24	9354.29
3	18		228"(5791mm)	TARP-42N8-	■	■	S	BNNN	4058.18	4792.78	4411.97	5146.57	6809.48	8503.16	7639.30	9615.96
3	18		234"(5944mm)	TARP-42P4-	■	■	S	BNNN	4165.51	4914.15	4528.61	5277.25	6972.39	8729.16	7827.69	9879.79
3	18		240"(6096mm)	TARP-42Q0-	■	■	S	BNNN	4272.84	5035.52	4645.25	5407.93	7135.57	8957.01	8016.40	10145.78
3	20		246"(6248mm)	TARP-42Q6-	■	■	S	BNNN	4380.17	5156.89	4761.89	5538.61	7299.01	9186.69	8205.44	10413.93
3	20		252"(6401mm)	TARP-42R2-	■	■	S	BNNN	4487.50	5278.26	4878.53	5669.29	7462.73	9418.21	8394.80	10684.24
3	20		258"(6553mm)	TARP-42R8-	■	■	S	BNNN	4594.83	5399.63	4995.17	5799.97	7626.71	9651.57	8584.48	10956.71
3	20		264"(6706mm)	TARP-42S4-	■	■	S	BNNN	4702.16	5521.00	5111.81	5930.65	7790.96	9886.78	8774.49	11231.34
3	22		270"(6858mm)	TARP-42T0-	■	■	S	BNNN	4809.49	5642.37	5228.45	6061.33	7955.47	10123.82	8964.82	11508.13
1	8	48"(1219mm)	96"(2438mm)	TARP-4896-	■	■	S	BNNN	\$1461.92	\$1840.48	\$1632.17	\$2010.73	\$2336.58	\$ 2894.13	\$ 2671.36	\$ 3310.27
1	8		102"(2591mm)	TARP-48A2-	■	■	S	BNNN	1557.08	1949.68	1737.97	2130.57	2487.19	3085.90	2849.32	3536.07
1	10		108"(2743mm)	TARP-48A8-	■	■	S	BNNN	1652.24	2058.88	1843.77	2250.41	2638.06	3279.50	3027.61	3764.03
1	10		114"(2896mm)	TARP-48B4-	■	■	S	BNNN	1747.40	2168.08	1949.57	2370.25	2789.21	3474.95	3206.22	3994.15
1	10		120"(3048mm)	TARP-48C0-	■	■	S	BNNN	1842.56	2277.28	2055.37	2490.09	2940.63	3672.23	3385.15	4226.43
2	10		126"(3200mm)	TARP-48C6-	■	■	S	BNNN	2543.38	3019.00	2766.83	3242.45	4435.17	5503.69	4907.27	6093.20
2	10		132"(3353mm)	TARP-48D2-	■	■	S	BNNN	2662.29	3151.95	2896.38	3386.04	4610.87	5723.66	5110.60	6348.80
2	12		138"(3505mm)	TARP-48D8-	■	■	S	BNNN	2781.20	3284.90	3025.93	3529.63	4786.83	5945.46	5314.26	6606.56
2	12		144"(3658mm)	TARP-48E4-	■	■	S	BNNN	2900.11	3417.85	3155.48	3673.22	4963.07	6169.11	5518.24	6866.48
2	12		150"(3810mm)	TARP-48F0-	■	■	S	BNNN	3019.02	3550.80	3285.03	3816.81	5139.57	6394.60	5722.54	7128.56
2	12		156"(3962mm)	TARP-48F6-	■	■	S	BNNN	3137.93	3683.75	3414.58	3960.40	5316.35	6621.93	5927.17	7392.80
2	14		162"(4115mm)	TARP-48G2-	■	■	S	BNNN	3256.84	3816.70	3544.13	4103.99	5493.38	6851.10	6132.12	7659.20
2	14		168"(4267mm)	TARP-48G8-	■	■	S	BNNN	3375.75	3949.65	3673.68	4247.58	5670.69	7082.10	6337.40	7927.76
2	14		174"(4420mm)	TARP-48H4-	■	■	S	BNNN	3494.66	4082.60	3803.23	4391.17	5848.27	7314.95	6543.00	8198.48
2	14		180"(4572mm)	TARP-48J0-	■	■	S	BNNN	3613.57	4215.55	3932.78	4534.76	6026.11	7549.64	6748.92	8471.36
3	14		186"(4724mm)	TARP-48J6-	■	■	S	BNNN	3744.37	4394.73	4074.22	4724.58	6446.18	7800.45	7197.13	8760.68
3	16		192"(4877mm)	TARP-48K2-	■	■	S	BNNN	3863.28	4527.68	4203.77	4868.17	6624.56	8031.70	7403.70	9030.76
3	16		198"(5029mm)	TARP-48K8-	■	■	S	BNNN	3982.19	4660.63	4333.32	5011.76	6803.20	8264.79	7610.60	9303.00
3	16		204"(5182mm)	TARP-48L4-	■	■	S	BNNN	4101.10	4793.58	4462.87	5155.35	6982.12	8499.72	7817.82	9577.40
3	16		210"(5334mm)	TARP-48M0-	■	■	S	BNNN	4220.01	4926.53	4592.42	5298.94	7161.30	8736.49	8025.36	9853.96
3	18		216"(5486mm)	TARP-48M6-	■	■	S	BNNN	4338.92	5059.48	4721.97	5442.53	7340.75	8975.10	8233.23	10132.68
3	18		222"(5639mm)	TARP-48N2-	■	■	S	BNNN	4457.83	5192.43	4851.52	5586.12	7520.47	9215.55	8441.42	10413.56
3	18		228"(5791mm)	TARP-48N8-	■	■	S	BNNN	4576.74	5325.38	4981.07	5729.71	7700.45	9457.85	8649.94	10696.60
3	18		234"(5944mm)	TARP-48P4-	■	■	S	BNNN	4695.65	5458.33	5110.62	5873.30	7880.71	9701.98	8858.78	10981.80
3	18		240"(6096mm)	TARP-48Q0-	■	■	S	BNNN	4814.56	5591.28	5240.17	6016.89	8061.23	9947.95	9067.94	11269.16
3	20		246"(6248mm)	TARP-48Q6-	■	■	S	BNNN	4933.47	5724.23	5369.72	6160.48	8242.02	10195.76	9277.43	11558.68
3	20		252"(6401mm)	TARP-48R2-	■	■	S	BNNN	5052.38	5857.18	5499.27	6304.07	8423.07	10445.42	9487.24	11850.36
3	20		258"(6553mm)	TARP-48R8-	■	■	S	BNNN	5171.29	5990.13	5628.82	6447.66	8604.40	10696.91	9697.38	12144.20
3	20		264"(6706mm)	TARP-48S4-	■	■	S	BNNN	5290.20	6123.08	5758.37	6591.25	8785.99	10950.24	9907.84	12440.20
3	22		270"(6858mm)	TARP-48T0-	■	■	S	BNNN	5409.11	6256.03	5887.92	6734.84	8967.85	11205.42	10118.62	12738.36

*Recommended seating capacity based upon 27"(687mm) per chair.

Planes Conference Table Top — Pebble (for use with Column Base)

Laminate or Wood

No. of Pieces	Seating Capacity*	Depth	Width	Number	① ② ③		Laminate A		Laminate B		Wood Group A		Wood Group B			
					J	F	J	F	K	U	K	U				
1	10	54"(1372mm)	96"(2438mm)	TARP-5496-	■	■	S	BNNN	\$1649.72	\$2042.32	\$1841.25	\$2233.85	\$ 3145.82	\$ 3840.68	\$ 3531.89	\$ 4311.50
1	10		102"(2591mm)	TARP-54A2-	■	■	S	BNNN	1756.46	2163.10	1959.96	2366.60	3313.77	4050.58	3730.30	4558.67
1	12		108"(2743mm)	TARP-54A8-	■	■	S	BNNN	1863.20	2283.88	2078.67	2499.35	3482.00	4262.31	3929.04	4808.00
1	12		114"(2896mm)	TARP-54B4-	■	■	S	BNNN	1969.94	2404.66	2197.38	2632.10	3650.49	4475.89	4128.10	5059.49
1	12		120"(3048mm)	TARP-54C0-	■	■	S	BNNN	2076.68	2525.44	2316.09	2764.85	3819.24	4691.31	4327.49	5313.14
2	12		126"(3200mm)	TARP-54C6-	■	■	S	BNNN	2865.08	3354.74	3116.46	3606.12	5449.89	6790.27	5988.82	7450.66
2	12		132"(3353mm)	TARP-54D2-	■	■	S	BNNN	2995.57	3499.27	3258.92	3762.62	5642.93	7028.37	6212.60	7727.63
2	14		138"(3505mm)	TARP-54D8-	■	■	S	BNNN	3126.06	3643.80	3401.38	3919.12	5836.25	7268.31	6436.71	8006.76
2	14		144"(3658mm)	TARP-54E4-	■	■	S	BNNN	3256.55	3788.33	3543.84	4075.62	6029.82	7510.08	6661.14	8288.05
2	14		150"(3810mm)	TARP-54F0-	■	■	S	BNNN	3387.04	3932.86	3686.30	4232.12	6223.67	7753.70	6885.90	8571.50
2	14		156"(3962mm)	TARP-54F6-	■	■	S	BNNN	3517.53	4077.39	3828.76	4388.62	6417.79	7999.16	7110.98	8857.11
2	16		162"(4115mm)	TARP-54G2-	■	■	S	BNNN	3648.02	4221.92	3971.22	4545.12	6612.17	8246.46	7336.38	9144.88
2	16		168"(4267mm)	TARP-54G8-	■	■	S	BNNN	3778.51	4366.45	4113.68	4701.62	6806.82	8495.60	7562.11	9434.81
2	16		174"(4420mm)	TARP-54H4-	■	■	S	BNNN	3909.00	4510.98	4256.14	4858.12	7001.74	8746.58	7788.16	9726.90
2	16		180"(4572mm)	TARP-54J0-	■	■	S	BNNN	4039.49	4655.51	4398.60	5014.62	7196.93	8999.39	8014.54	10021.15
3	16		186"(4724mm)	TARP-54J6-	■	■	S	BNNN	4113.47	4846.27	4484.55	5217.35	7740.04	9268.33	8588.90	10331.84
3	18		192"(4877mm)	TARP-54K2-	■	■	S	BNNN	4243.96	4990.80	4627.01	5373.85	7935.76	9517.71	8815.92	10623.29
3	18		198"(5029mm)	TARP-54K8-	■	■	S	BNNN	4374.45	5135.33	4769.47	5530.35	8131.75	9768.93	9043.27	10916.90
3	18		204"(5182mm)	TARP-54L4-	■	■	S	BNNN	4504.94	5279.86	4911.93	5686.85	8328.01	10022.00	9270.94	11212.67
3	18		210"(5334mm)	TARP-54M0-	■	■	S	BNNN	4635.43	5424.39	5054.39	5843.35	8524.54	10276.90	9498.94	11510.60
3	20		216"(5486mm)	TARP-54M6-	■	■	S	BNNN	4765.92	5568.92	5196.85	5999.85	8721.33	10533.64	9727.26	11810.69
3	20		222"(5639mm)	TARP-54N2-	■	■	S	BNNN	4896.41	5713.45	5339.31	6156.35	8918.39	10792.22	9955.90	12112.94
3	20		228"(5791mm)	TARP-54N8-	■	■	S	BNNN	5026.90	5857.98	5481.77	6312.85	9115.72	11052.64	10184.87	12417.35
3	20		234"(5944mm)	TARP-54P4-	■	■	S	BNNN	5157.39	6002.51	5624.23	6469.35	9313.32	11314.90	10414.16	12723.92
3	20		240"(6096mm)	TARP-54Q0-	■	■	S	BNNN	5287.88	6147.04	5766.69	6625.85	9511.18	11579.01	10643.78	13032.65
3	22		246"(6248mm)	TARP-54Q6-	■	■	S	BNNN	5418.37	6291.57	5909.15	6782.35	9709.32	11844.95	10873.72	13343.54
3	22		252"(6401mm)	TARP-54R2-	■	■	S	BNNN	5548.86	6436.10	6051.61	6938.85	9907.72	12112.73	11103.98	13656.59
3	22		258"(6553mm)	TARP-54R8-	■	■	S	BNNN	5679.35	6580.63	6194.07	7095.35	10106.39	12382.35	11334.57	13971.80
3	22		264"(6706mm)	TARP-54S4-	■	■	S	BNNN	5809.84	6725.16	6336.53	7251.85	10305.32	12653.82	11565.48	14289.17
3	24		270"(6858mm)	TARP-54T0-	■	■	S	BNNN	5940.33	6869.69	6478.99	7408.35	10504.53	12927.12	11796.72	14608.70
1	10	60"(1524mm)	96"(2438mm)	TARP-6096-	■	■	S	BNNN	\$1837.52	\$2244.16	\$2050.33	\$2456.97	\$ 3487.75	\$ 4208.41	\$ 3925.11	\$ 4733.91
1	10		102"(2591mm)	TARP-60A2-	■	■	S	BNNN	1955.84	2376.52	2181.95	2602.63	3673.05	4436.44	4143.98	5002.45
1	12		108"(2743mm)	TARP-60A8-	■	■	S	BNNN	2074.16	2508.88	2313.57	2748.29	3858.62	4666.31	4363.17	5273.15
1	12		114"(2896mm)	TARP-60B4-	■	■	S	BNNN	2192.48	2641.24	2445.19	2893.95	4044.45	4898.01	4582.68	5546.01
1	12		120"(3048mm)	TARP-60C0-	■	■	S	BNNN	2310.80	2773.60	2576.81	3039.61	4230.55	5131.56	4802.52	5821.03
2	12		126"(3200mm)	TARP-60C6-	■	■	S	BNNN	3186.78	3690.48	3466.09	3969.79	5997.30	7498.03	6603.06	8229.30
2	12		132"(3353mm)	TARP-60D2-	■	■	S	BNNN	3328.85	3846.59	3621.46	4139.20	6207.69	7754.26	6847.30	8527.64
2	14		138"(3505mm)	TARP-60D8-	■	■	S	BNNN	3470.92	4002.70	3776.83	4308.61	6418.35	8012.33	7091.86	8828.14
2	14		144"(3658mm)	TARP-60E4-	■	■	S	BNNN	3612.99	4158.81	3932.20	4478.02	6629.27	8272.24	7336.74	9130.80
2	14		150"(3810mm)	TARP-60F0-	■	■	S	BNNN	3755.06	4314.92	4087.57	4647.43	6840.46	8533.98	7581.95	9435.62
2	14		156"(3962mm)	TARP-60F6-	■	■	S	BNNN	3897.13	4471.03	4242.94	4816.84	7051.92	8797.57	7827.48	9742.60
2	16		162"(4115mm)	TARP-60G2-	■	■	S	BNNN	4039.20	4627.14	4398.31	4986.25	7263.65	9063.00	8073.34	10051.74
2	16		168"(4267mm)	TARP-60G8-	■	■	S	BNNN	4181.27	4783.25	4553.68	5155.66	7475.64	9330.27	8319.52	10363.04
2	16		174"(4420mm)	TARP-60H4-	■	■	S	BNNN	4323.34	4939.36	4709.05	5325.07	7687.90	9599.38	8566.02	10676.50
2	16		180"(4572mm)	TARP-60J0-	■	■	S	BNNN	4465.41	5095.47	4864.42	5494.48	7900.43	9870.33	8812.85	10992.12
3	16		186"(4724mm)	TARP-60J6-	■	■	S	BNNN	4482.57	5297.81	4894.88	5710.12	8566.59	10157.40	9513.36	11324.18
3	18		192"(4877mm)	TARP-60K2-	■	■	S	BNNN	4624.64	5453.92	5050.25	5879.53	8779.66	10424.91	9760.84	11637.00
3	18		198"(5029mm)	TARP-60K8-	■	■	S	BNNN	4766.71	5610.03	5205.62	6048.94	8992.99	10694.26	10008.64	11951.98
3	18		204"(5182mm)	TARP-60L4-	■	■	S	BNNN	4908.78	5766.14	5360.99	6218.35	9206.59	10965.45	10256.76	12269.12
3	18		210"(5334mm)	TARP-60M0-	■	■	S	BNNN	5050.85	5922.25	5516.36	6387.76	9420.46	11238.48	10505.21	12588.42
3	20		216"(5486mm)	TARP-60M6-	■	■	S	BNNN	5192.92	6078.36	5671.73	6557.17	9634.60	11513.35	10753.98	12909.88
3	20		222"(5639mm)	TARP-60N2-	■	■	S	BNNN	5334.99	6234.47	5827.10	6726.58	9849.01	11790.06	11003.08	13233.50
3	20		228"(5791mm)	TARP-60N8-	■	■	S	BNNN	5477.06	6390.58	5982.47	6895.99	10063.68	12068.62	11252.50	13559.28
3	20		234"(5944mm)	TARP-60P4-	■	■	S	BNNN	5619.13	6546.69	6137.84	7065.40	10278.62	12349.01	11502.24	13887.22
3	20		240"(6096mm)	TARP-60Q0-	■	■	S	BNNN	5761.20	6702.80	6293.21	7234.81	10493.83	12631.24	11752.31	14217.32
3	22		246"(6248mm)	TARP-60Q6-	■	■	S	BNNN	5903.27	6858.91	6448.58	7404.22	10709.31	12915.31	12002.70	14549.58
3	22		252"(6401mm)	TARP-60R2-	■	■	S	BNNN	6045.34	7015.02	6603.95	7573.63	10925.05	13201.23	12253.42	14884.00
3	22		258"(6553mm)	TARP-60R8-	■	■	S	BNNN	6187.41	7171.13	6759.32	7743.04	11141.06	13488.98	12504.46	15220.58
3	22		264"(6706mm)	TARP-60S4-	■	■	S	BNNN	6329.48	7327.24	6914.69	7912.45	11357.34	13778.57	12755.82	15559.32
3	24		270"(6858mm)	TARP-60T0-	■	■	S	BNNN	6471.55	7483.35	7070.06	8081.86	11573.89	14070.01	13007.51	15900.22

*Recommended seating capacity based upon 27"(687mm) per chair.

This page intentionally blank

Planes Conference Table Top — Hexagon (for use with Column Base)

Laminate or Wood

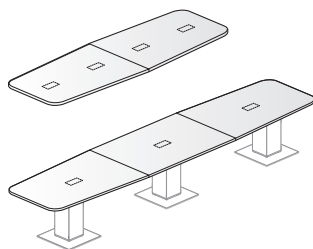

TARX

Features

- Includes 1 3/16" (30mm) thick top(s).
- Laminate top with 3mm edgeband or knife edge, or wood veneer top with 3mm wood edgeband or knife edge on user edges. Multiple piece tops are 1mm edgeband at the seams.
- Table top seams are 1mm edgeband.
- **Requires separately specified Column Base and J Channels.**
- Optional power modules are separately specified.
- Depth and width shown in nominal dimensions.

Specification Tips

- Multiple piece conference tops have equal sized pieces and are shipped unassembled.
- Conference Top requires separately specified components for Column Base:
 - Column Frame
 - Column Base Plate
 - Cladding (4) pieces per each Column Frame
- Conference Top requires separately specified J Channels for support and load purposes.
- Cutouts are optional. If specified they are factory installed.
- Each cutout requires a separately specified flip top unit electrical module or a select workware interface module (see workware price list).
- Separately specified Planes grommets are available for field installation.
- For separately specified required components refer to the **Component Specification Overview** located in the front of the price list; see Planes Conference Table Tops (for use with Column Base).

3 Cutout Options

Cutout	1 Piece	2 Piece	3 Piece
F	\$33.13	\$ 66.26	\$ 99.39
V	\$66.26	\$132.52	\$198.78
J	\$33.13	\$ 66.26	\$ 99.39
K	\$66.26	\$132.52	\$198.78
M	\$33.13	\$ 66.26	\$ 99.39
P	\$66.26	\$132.52	\$198.78
Q	\$33.13	\$ 66.26	\$ 99.39
T	\$66.26	\$132.52	\$198.78

To Order, Specify:

1) Product number, including;

1 Surface Options:

L Laminate

W Wood

2 Edge Options:

Laminate:

J Edgeband

F Knife

Wood:

K Wood Edgeband

U Knife

3 Cutout Options:

N No Cutout

F Center, Single-Sided/4 outlets, see chart for upcharge

V Left/Right, Single-Sided/4 outlets, see chart for upcharge

J Center, Single-Sided/6 outlets, see chart for upcharge

K Left/Right, Single-Sided/6 outlets, see chart for upcharge

M Center, Double-Sided/8 outlets, see chart for upcharge

P Left/Right, Double-Sided/8 outlets, see chart for upcharge

Q Center, Double-Sided/12 outlets, see chart for upcharge

T Left/Right, Double-Sided/12 outlets, see chart for upcharge

2) Laminate surface color or wood finish color.

3) Edgeband trim color (laminated only).

Planes Conference Table Top — Hexagon (for use with Column Base)

Laminate or Wood

No. of Pieces	Seating Capacity*	Depth	Width	Number ① ② ③	Laminate A		Laminate B		Wood Group A		Wood Group B						
					J	F	J	F	K	U	K	U					
1	8	42"(1067mm)	96"(2438mm)	TARX-4296-	■	■	■	■	BNNN	\$1274.12	\$1638.64	\$1423.09	\$1787.61	\$2051.63	\$ 2587.69	\$ 2335.13	\$ 2949.15
1	8		102"(2591mm)	TARX-42A2-	■	■	■	■	BNNN	1357.70	1736.26	1515.98	1894.54	2184.90	2761.33	2492.64	3153.58
1	10		108"(2743mm)	TARX-42A8-	■	■	■	■	BNNN	1441.28	1833.88	1608.87	2001.47	2318.43	2936.80	2650.47	3360.17
1	10		114"(2896mm)	TARX-42B4-	■	■	■	■	BNNN	1524.86	1931.50	1701.76	2108.40	2452.24	3114.12	2808.63	3568.92
1	10		120"(3048mm)	TARX-42C0-	■	■	■	■	BNNN	1608.44	2029.12	1794.65	2215.33	2586.31	3293.27	2967.11	3779.83
2	10		126"(3200mm)	TARX-42C6-	■	■	■	■	BNNN	2221.68	2683.26	2417.20	2878.78	3944.74	4857.22	4350.02	5375.85
2	10		132"(3353mm)	TARX-42D2-	■	■	■	■	BNNN	2329.01	2804.63	2533.84	3009.46	4103.10	5059.06	4532.90	5610.08
2	12		138"(3505mm)	TARX-42D8-	■	■	■	■	BNNN	2436.34	2926.00	2650.48	3140.14	4261.72	5262.73	4716.10	5846.47
2	12		144"(3658mm)	TARX-42E4-	■	■	■	■	BNNN	2543.67	3047.37	2767.12	3270.82	4420.62	5468.25	4899.63	6085.02
2	12		150"(3810mm)	TARX-42F0-	■	■	■	■	BNNN	2651.00	3168.74	2883.76	3401.50	4579.78	5675.61	5083.48	6325.73
2	12		156"(3962mm)	TARX-42F6-	■	■	■	■	BNNN	2758.33	3290.11	3000.40	3532.18	4739.20	5884.80	5267.66	6568.60
2	14		162"(4115mm)	TARX-42G2-	■	■	■	■	BNNN	2865.66	3411.48	3117.04	3662.86	4898.90	6095.84	5452.16	6813.63
2	14		168"(4267mm)	TARX-42G8-	■	■	■	■	BNNN	2972.99	3532.85	3233.68	3793.54	5058.86	6308.72	5636.98	7060.82
2	14		174"(4420mm)	TARX-42H4-	■	■	■	■	BNNN	3080.32	3654.22	3350.32	3924.22	5219.09	6523.44	5822.13	7310.17
2	14		180"(4572mm)	TARX-42J0-	■	■	■	■	BNNN	3187.65	3775.59	3466.96	4054.90	5379.59	6740.00	6007.60	7561.68
3	14		186"(4724mm)	TARX-42J6-	■	■	■	■	BNNN	3306.87	3943.19	3595.49	4231.81	5676.62	7202.68	6329.66	7829.63
3	16		192"(4877mm)	TARX-42K2-	■	■	■	■	BNNN	3414.20	4064.56	3712.13	4362.49	5837.65	7185.80	6515.78	8078.34
3	16		198"(5029mm)	TARX-42K8-	■	■	■	■	BNNN	3521.53	4185.93	3828.77	4493.17	5998.95	7400.76	6702.22	8329.21
3	16		204"(5182mm)	TARX-42L4-	■	■	■	■	BNNN	3628.86	4307.30	3945.41	4623.85	6160.52	7617.56	6888.99	8582.24
3	16		210"(5334mm)	TARX-42M0-	■	■	■	■	BNNN	3736.19	4428.67	4062.05	4754.53	6322.36	7836.20	7076.08	8837.43
3	18		216"(5486mm)	TARX-42M6-	■	■	■	■	BNNN	3843.52	4550.04	4178.69	4885.21	6484.47	8056.68	7263.50	9094.78
3	18		222"(5639mm)	TARX-42N2-	■	■	■	■	BNNN	3950.85	4671.41	4295.33	5015.89	6646.84	8279.00	7451.24	9354.29
3	18		228"(5791mm)	TARX-42N8-	■	■	■	■	BNNN	4058.18	4792.78	4411.97	5146.57	6809.48	8503.16	7639.30	9615.96
3	18		234"(5944mm)	TARX-42P4-	■	■	■	■	BNNN	4165.51	4914.15	4528.61	5277.25	6972.39	8729.16	7827.69	9879.79
3	18		240"(6096mm)	TARX-42Q0-	■	■	■	■	BNNN	4272.84	5035.52	4645.25	5407.93	7135.57	8957.01	8016.40	10145.78
3	20		246"(6248mm)	TARX-42Q6-	■	■	■	■	BNNN	4380.17	5156.89	4761.89	5538.61	7299.01	9186.69	8205.44	10413.93
3	20		252"(6401mm)	TARX-42R2-	■	■	■	■	BNNN	4487.50	5278.26	4878.53	5669.29	7462.73	9418.21	8394.80	10684.24
3	20		258"(6553mm)	TARX-42R8-	■	■	■	■	BNNN	4594.83	5399.63	4995.17	5799.97	7626.71	9651.57	8584.48	10956.71
3	20		264"(6706mm)	TARX-42S4-	■	■	■	■	BNNN	4702.16	5521.00	5111.81	5930.65	7790.96	9886.78	8774.49	11231.34
3	22		270"(6858mm)	TARX-42T0-	■	■	■	■	BNNN	4809.49	5642.37	5228.45	6061.33	7955.47	10123.82	8964.82	11508.13
1	8	48"(1219mm)	96"(2438mm)	TARX-4896-	■	■	■	■	BNNN	\$1461.92	\$1840.48	\$1632.17	\$2010.73	\$2336.58	\$ 2894.13	\$ 2671.36	\$ 3310.27
1	8		102"(2591mm)	TARX-48A2-	■	■	■	■	BNNN	1557.08	1949.68	1737.97	2130.57	2487.19	3085.90	2849.32	3536.07
1	10		108"(2743mm)	TARX-48A8-	■	■	■	■	BNNN	1652.24	2058.88	1843.77	2250.41	2638.06	3279.50	3027.61	3764.03
1	10		114"(2896mm)	TARX-48B4-	■	■	■	■	BNNN	1747.40	2168.08	1949.57	2370.25	2789.21	3474.95	3206.22	3994.15
1	10		120"(3048mm)	TARX-48C0-	■	■	■	■	BNNN	1842.56	2277.28	2055.37	2490.09	2940.63	3672.23	3385.15	4226.43
2	10		126"(3200mm)	TARX-48C6-	■	■	■	■	BNNN	2543.38	3019.00	2766.83	3242.45	4435.17	5503.69	4907.27	6093.20
2	10		132"(3353mm)	TARX-48D2-	■	■	■	■	BNNN	2662.29	3151.95	2896.38	3386.04	4610.87	5723.66	5110.60	6348.80
2	12		138"(3505mm)	TARX-48D8-	■	■	■	■	BNNN	2781.20	3284.90	3025.93	3529.63	4786.83	5945.46	5314.26	6606.56
2	12		144"(3658mm)	TARX-48E4-	■	■	■	■	BNNN	2900.11	3417.85	3155.48	3673.22	4963.07	6169.11	5518.24	6866.48
2	12		150"(3810mm)	TARX-48F0-	■	■	■	■	BNNN	3019.02	3550.80	3285.03	3816.81	5139.57	6394.60	5722.54	7128.56
2	12		156"(3962mm)	TARX-48F6-	■	■	■	■	BNNN	3137.93	3683.75	3414.58	3960.40	5316.35	6621.93	5927.17	7392.80
2	14		162"(4115mm)	TARX-48G2-	■	■	■	■	BNNN	3256.84	3816.70	3544.13	4103.99	5493.38	6851.10	6132.12	7659.20
2	14		168"(4267mm)	TARX-48G8-	■	■	■	■	BNNN	3375.75	3949.65	3673.68	4247.58	5670.69	7082.10	6337.40	7927.76
2	14		174"(4420mm)	TARX-48H4-	■	■	■	■	BNNN	3494.66	4082.60	3803.23	4391.17	5848.27	7314.95	6543.00	8198.48
2	14		180"(4572mm)	TARX-48J0-	■	■	■	■	BNNN	3613.57	4215.55	3932.78	4534.76	6026.11	7549.64	6748.92	8471.36
3	14		186"(4724mm)	TARX-48J6-	■	■	■	■	BNNN	3744.37	4394.73	4074.22	4724.58	6446.18	7800.45	7197.13	8760.68
3	16		192"(4877mm)	TARX-48K2-	■	■	■	■	BNNN	3863.28	4527.68	4203.77	4868.17	6624.56	8031.70	7403.70	9030.76
3	16		198"(5029mm)	TARX-48K8-	■	■	■	■	BNNN	3982.19	4660.63	4333.32	5011.76	6803.20	8264.79	7610.60	9303.00
3	16		204"(5182mm)	TARX-48L4-	■	■	■	■	BNNN	4101.10	4793.58	4462.87	5155.35	6982.12	8499.72	7817.82	9577.40
3	16		210"(5334mm)	TARX-48M0-	■	■	■	■	BNNN	4220.01	4926.53	4592.42	5298.94	7161.30	8736.49	8025.36	9853.96
3	18		216"(5486mm)	TARX-48M6-	■	■	■	■	BNNN	4338.92	5059.48	4721.97	5442.53	7340.75	8975.10	8233.23	10132.68
3	18		222"(5639mm)	TARX-48N2-	■	■	■	■	BNNN	4457.83	5192.43	4851.52	5586.12	7520.47	9215.55	8441.42	10413.56
3	18		228"(5791mm)	TARX-48N8-	■	■	■	■	BNNN	4576.74	5325.38	4981.07	5729.71	7700.45	9457.85	8649.94	10696.60
3	18		234"(5944mm)	TARX-48P4-	■	■	■	■	BNNN	4695.65	5458.33	5110.62	5873.30	7880.71	9701.98	8858.78	10981.80
3	18		240"(6096mm)	TARX-48Q0-	■	■	■	■	BNNN	4814.56	5591.28	5240.17	6016.89	8061.23	9947.95	9067.94	11269.16
3	20		246"(6248mm)	TARX-48Q6-	■	■	■	■	BNNN	4933.47	5724.23	5369.72	6160.48	8242.02	10195.76	9277.43	11558.68
3	20		252"(6401mm)	TARX-48R2-	■	■	■	■	BNNN	5052.38	5857.18	5499.27	6304.07	8423.07	10445.42	9487.24	11850.36
3	20		258"(6553mm)	TARX-48R8-	■	■	■	■	BNNN	5171.29	5990.13	5628.82	6447.66	8604.40	10696.91	9697.38	12144.20
3	20		264"(6706mm)	TARX-48S4-	■	■	■	■	BNNN	5290.20	6123.08	5758.37	6591.25	8785.99	10950.24	9907.84	12440.20
3	22		270"(6858mm)	TARX-48T0-	■	■	■	■	BNNN	5409.11	6256.03	5887.92	6734.84	8967.85	11205.42	10118.62	12738.36

*Recommended seating capacity based upon 27"(687mm) per chair.

Planes Conference Table Top — Hexagon (for use with Column Base)

Laminate or Wood

No. of Pieces	Seating Capacity*	Depth	Width	Number ① ② ③	Laminate A		Laminate B		Wood Group A		Wood Group B	
					J	F	J	F	K	U	K	U
1	10	54"(1372mm)	96"(2438mm)	TARX-5496-■ ■ S ■ BNNN	\$1649.72	\$2042.32	\$1841.25	\$2233.85	\$ 3145.82	\$ 3840.68	\$ 3531.89	\$ 4311.50
1	10		102"(2591mm)	TARX-54A2-■ ■ S ■ BNNN	1756.46	\$2163.10	\$1959.96	\$2366.60	3313.77	4050.58	3730.30	4558.67
1	12		108"(2743mm)	TARX-54A8-■ ■ S ■ BNNN	1863.20	\$2283.88	\$2078.67	\$2499.35	3482.00	4262.31	3929.04	4808.00
1	12		114"(2896mm)	TARX-54B4-■ ■ S ■ BNNN	1969.94	\$2404.66	\$2197.38	\$2632.10	3650.49	4475.89	4128.10	5059.49
1	12		120"(3048mm)	TARX-54C0-■ ■ S ■ BNNN	2076.68	\$2525.44	\$2316.09	\$2764.85	3819.24	4691.31	4327.49	5313.14
2	12		126"(3200mm)	TARX-54C6-■ ■ S ■ BNNN	2865.08	\$3354.74	\$3116.46	\$3606.12	5449.89	6790.27	5988.82	7450.66
2	12		132"(3353mm)	TARX-54D2-■ ■ S ■ BNNN	2995.57	3499.27	3258.92	3762.62	5642.93	7028.37	6212.60	7727.63
2	12		138"(3505mm)	TARX-54D8-■ ■ S ■ BNNN	3126.06	3643.80	3401.38	3919.12	5836.25	7268.31	6436.71	8006.76
2	14		144"(3658mm)	TARX-54E4-■ ■ S ■ BNNN	3256.55	3788.33	3543.84	4075.62	6029.82	7510.08	6661.14	8288.05
2	14		150"(3810mm)	TARX-54F0-■ ■ S ■ BNNN	3387.04	3932.86	3686.30	4232.12	6223.67	7753.70	6885.90	8571.50
2	14		156"(3962mm)	TARX-54F6-■ ■ S ■ BNNN	3517.53	4077.39	3828.76	4388.62	6417.79	7999.16	7110.98	8857.11
2	16		162"(4115mm)	TARX-54G2-■ ■ S ■ BNNN	3648.02	4221.92	3971.22	4545.12	6612.17	8246.46	7336.38	9144.88
2	16		168"(4267mm)	TARX-54G8-■ ■ S ■ BNNN	3778.51	4366.45	4113.68	4701.62	6806.82	8495.60	7562.11	9434.81
2	16		174"(4420mm)	TARX-54H4-■ ■ S ■ BNNN	3909.00	4510.98	4256.14	4858.12	7001.74	8746.58	7788.16	9726.90
2	16		180"(4572mm)	TARX-54J0-■ ■ S ■ BNNN	4039.49	4655.51	4398.60	5014.62	7196.93	8999.39	8014.54	10021.15
3	16		186"(4724mm)	TARX-54J6-■ ■ S ■ BNNN	4113.47	4846.27	4484.55	5217.35	7740.04	9268.33	8588.90	10331.84
3	18		192"(4877mm)	TARX-54K2-■ ■ S ■ BNNN	4243.96	4990.80	4627.01	5373.85	7935.76	9517.71	8815.92	10623.29
3	18		198"(5029mm)	TARX-54K8-■ ■ S ■ BNNN	4374.45	5135.33	4769.47	5530.35	8131.75	9768.93	9043.27	10916.90
3	18		204"(5182mm)	TARX-54L4-■ ■ S ■ BNNN	4504.94	5279.86	4911.93	5686.85	8328.01	10022.00	9270.94	11212.67
3	18		210"(5334mm)	TARX-54M0-■ ■ S ■ BNNN	4635.43	5424.39	5054.39	5843.35	8524.54	10276.90	9498.94	11510.60
3	20		216"(5486mm)	TARX-54M6-■ ■ S ■ BNNN	4765.92	5568.92	5196.85	5999.85	8721.33	10533.64	9727.26	11810.69
3	20		222"(5639mm)	TARX-54N2-■ ■ S ■ BNNN	4896.41	5713.45	5339.31	6156.35	8918.39	10792.22	9955.90	12112.94
3	20		228"(5791mm)	TARX-54N8-■ ■ S ■ BNNN	5026.90	5857.98	5481.77	6312.85	9115.72	11052.64	10184.87	12417.35
3	20		234"(5944mm)	TARX-54P4-■ ■ S ■ BNNN	5157.39	6002.51	5624.23	6469.35	9313.32	11314.90	10414.16	12723.92
3	20		240"(6096mm)	TARX-54Q0-■ ■ S ■ BNNN	5287.88	6147.04	5766.69	6625.85	9511.18	11579.01	10643.78	13032.65
3	22		246"(6248mm)	TARX-54Q6-■ ■ S ■ BNNN	5418.37	6291.57	5909.15	6782.35	9709.32	11844.95	10873.72	13343.54
3	22		252"(6401mm)	TARX-54R2-■ ■ S ■ BNNN	5548.86	6436.10	6051.61	6938.85	9907.72	12112.73	11103.98	13656.59
3	22		258"(6553mm)	TARX-54R8-■ ■ S ■ BNNN	5679.35	6580.63	6194.07	7095.35	10106.39	12382.35	11334.57	13971.80
3	22		264"(6706mm)	TARX-54S4-■ ■ S ■ BNNN	5809.84	6725.16	6336.53	7251.85	10305.32	12653.82	11565.48	14289.17
3	24		270"(6858mm)	TARX-54T0-■ ■ S ■ BNNN	5940.33	6869.69	6478.99	7408.35	10504.53	12927.12	11796.72	14608.70
1	10	60"(1524mm)	96"(2438mm)	TARX-6096-■ ■ S ■ BNNN	\$1837.52	\$2244.16	\$2050.33	\$2456.97	\$ 3487.75	\$ 4208.41	\$ 3925.11	\$ 4733.91
1	10		102"(2591mm)	TARX-60A2-■ ■ S ■ BNNN	1955.84	\$2376.52	\$2181.95	\$2602.63	3673.05	4436.44	4143.98	5002.45
1	12		108"(2743mm)	TARX-60A8-■ ■ S ■ BNNN	2074.16	\$2508.88	\$2313.57	\$2748.29	3858.62	4666.31	4363.17	5273.15
1	12		114"(2896mm)	TARX-60B4-■ ■ S ■ BNNN	2192.48	\$2641.24	\$2445.19	\$2893.95	4044.45	4898.01	4582.68	5546.01
1	12		120"(3048mm)	TARX-60C0-■ ■ S ■ BNNN	2310.80	\$2773.60	\$2576.81	\$3039.61	4230.55	5131.56	4802.52	5821.03
2	12		126"(3200mm)	TARX-60C6-■ ■ S ■ BNNN	3186.78	\$3690.48	\$3466.09	\$3969.79	5997.30	7498.03	6603.06	8229.30
2	12		132"(3353mm)	TARX-60D2-■ ■ S ■ BNNN	3328.85	3846.59	3621.46	4139.20	6207.69	7754.26	6847.30	8527.64
2	14		138"(3505mm)	TARX-60D8-■ ■ S ■ BNNN	3470.92	4002.70	3776.83	4308.61	6418.35	8012.33	7091.86	8828.14
2	14		144"(3658mm)	TARX-60E4-■ ■ S ■ BNNN	3612.99	4158.81	3932.20	4478.02	6629.27	8272.24	7336.74	9130.80
2	14		150"(3810mm)	TARX-60F0-■ ■ S ■ BNNN	3755.06	4314.92	4087.57	4647.43	6840.46	8533.98	7581.95	9435.62
2	14		156"(3962mm)	TARX-60F6-■ ■ S ■ BNNN	3897.13	4471.03	4242.94	4816.84	7051.92	8797.57	7827.48	9742.60
2	16		162"(4115mm)	TARX-60G2-■ ■ S ■ BNNN	4039.20	4627.14	4398.31	4986.25	7263.65	9063.00	8073.34	10051.74
2	16		168"(4267mm)	TARX-60G8-■ ■ S ■ BNNN	4181.27	4783.25	4553.68	5155.66	7475.64	9330.27	8319.52	10363.04
2	16		174"(4420mm)	TARX-60H4-■ ■ S ■ BNNN	4323.34	4939.36	4709.05	5325.07	7687.90	9599.38	8566.02	10676.50
2	16		180"(4572mm)	TARX-60J0-■ ■ S ■ BNNN	4465.41	5095.47	4864.42	5494.48	7900.43	9870.33	8812.85	10992.12
3	16		186"(4724mm)	TARX-60J6-■ ■ S ■ BNNN	4482.57	5297.81	4894.88	5710.12	8566.59	10157.40	9513.36	11324.18
3	18		192"(4877mm)	TARX-60K2-■ ■ S ■ BNNN	4624.64	5453.92	5050.25	5879.53	8779.66	10424.91	9760.84	11637.00
3	18		198"(5029mm)	TARX-60K8-■ ■ S ■ BNNN	4766.71	5610.03	5205.62	6048.94	8992.99	10694.26	10008.64	11951.98
3	18		204"(5182mm)	TARX-60L4-■ ■ S ■ BNNN	4908.78	5766.14	5360.99	6218.35	9206.59	10965.45	10256.76	12269.12
3	18		210"(5334mm)	TARX-60M0-■ ■ S ■ BNNN	5050.85	5922.25	5516.36	6387.76	9420.46	11238.48	10505.21	12588.42
3	20		216"(5486mm)	TARX-60M6-■ ■ S ■ BNNN	5192.92	6078.36	5671.73	6557.17	9634.60	11513.35	10753.98	12909.88
3	20		222"(5639mm)	TARX-60N2-■ ■ S ■ BNNN	5334.99	6234.47	5827.10	6726.58	9849.01	11790.06	11003.08	13233.50
3	20		228"(5791mm)	TARX-60N8-■ ■ S ■ BNNN	5477.06	6390.58	5982.47	6895.99	10063.68	12068.62	11252.50	13559.28
3	20		234"(5944mm)	TARX-60P4-■ ■ S ■ BNNN	5619.13	6546.69	6137.84	7065.40	10278.62	12349.01	11502.24	13887.22
3	20		240"(6096mm)	TARX-60Q0-■ ■ S ■ BNNN	5761.20	6702.80	6293.21	7234.81	10493.83	12631.24	11752.31	14217.32
3	22		246"(6248mm)	TARX-60Q6-■ ■ S ■ BNNN	5903.27	6858.91	6448.58	7404.22	10709.31	12915.31	12002.70	14549.58
3	22		252"(6401mm)	TARX-60R2-■ ■ S ■ BNNN	6045.34	7015.02	6603.95	7573.63	10925.05	13201.23	12253.42	14884.00
3	22		258"(6553mm)	TARX-60R8-■ ■ S ■ BNNN	6187.41	7171.13	6759.32	7743.04	11141.06	13488.98	12504.46	15220.58
3	22		264"(6706mm)	TARX-60S4-■ ■ S ■ BNNN	6329.48	7327.24	6914.69	7912.45	11357.34	13778.57	12755.82	15559.32
3	24		270"(6858mm)	TARX-60T0-■ ■ S ■ BNNN	6471.55	7483.35	7070.06	8081.86	11573.89	14070.01	13007.51	15900.22

*Recommended seating capacity based upon 27"(687mm) per chair.

This page intentionally blank

Planes End Supported Top — workware Tables

EXAMPLE: Planes, Key Conference End, 60" x 66", Laminate, Knife Edge, Standard Core, workware 4 Port Wide Switching, Center, Column Base

TA RY - 60 66 - L F S H B N N N

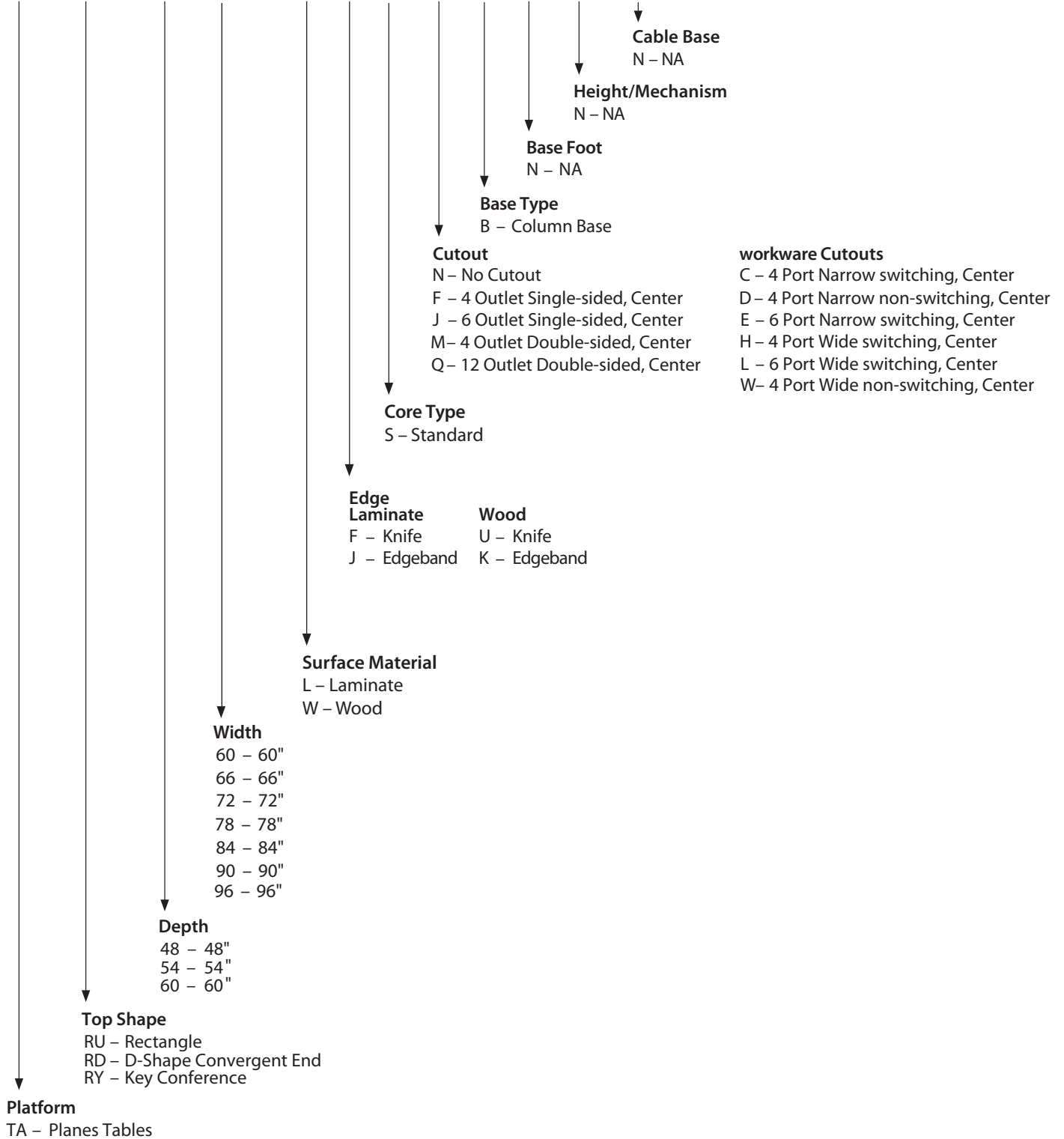

Component Specification Overview

Planes End Supported Top with Column Base

The outboard end of an End Supported Top requires a column base for floor support and the opposite end requires brackets for attachment to a structural wall, Compose or Enclose panel. See below for required component specification.

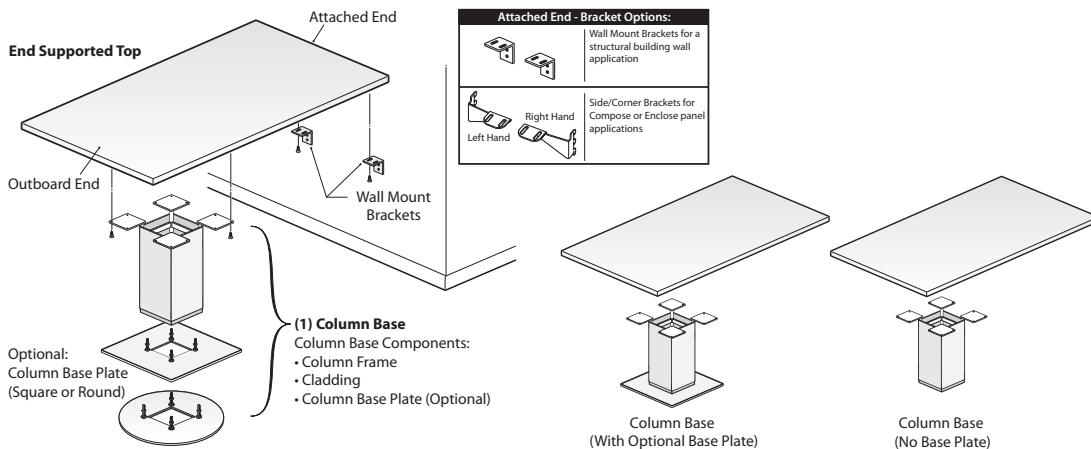

1 End Supported Top

- Always a 1-piece top.
 - Requires one column base for floor support and brackets for attachment to a structural building wall, Compose or Enclose panel.

Floor Support: Column Base

Each Column Base requires separately specified components: **Column Frame and Cladding. The Column Base Plate is optional.**

2 Column Frame

- Column Frames are square and are available in two sizes, 9”(229mm) & 12”(305mm) square, and three heights, 20”(508mm) lounge height, 28”(711mm) seated height and 40”(1016mm) standing height.
 - One Column Frame is required per End Supported Top.
 - The table top depth dictates the column frame size, 9”(229mm) or 12”(305mm) square. **Refer to Matrix-A for details.**

3 Column Base Plate - Optional

- **Column Base Plate is an optional component for an End Support Top.** (Note: Required for a Conference Table with Column Base)
- Round or Square Column Base Plates are available in four sizes: 21”(533mm), 24”(610mm), 27”(686mm) and 30”(762mm).
 - The column base plate size is specific to the column frame size of 9”(229mm) or 12”(305mm); specify accordingly.
 - The column frame width and the table top depth dictate the size of the column base plate. **Refer to Matrix-A for details.**

4 Cladding

- Round or Flat Cladding is available in two widths, 9”(229mm) & 12”(305mm), and three heights, 20”(508mm) lounge height, 28”(711mm) seated height and 40”(1016mm) standing height. (Exception: Round cladding is not available 40" high)
 - Cladding is specified as one single piece per catalog number. A quantity of (4) pieces are required per each Column Frame.
 - Note: All round or flat, or a combination of round and flat cladding may be used on a column frame.
 - Specify cladding to match the column frame width and height.

NOTE: J-Channel and J-Channel Tray are not required for an End Supported Top.

MATRIX - A

Column Frame Size / Base Plate Size - Specification Matrix					
Table Depth	9”(229mm) x 9”(229mm) Column Frame		12”(305mm) x 12”(305mm) Column Frame		
	21”(533mm) Base Plate (Round or Square)	24”(610mm) Base Plate (Round or Square)	24”(610mm) Base Plate (Round or Square)	27”(686mm) Base Plate (Round or Square)	30”(762mm) Base Plate (Round or Square)
36”(914mm)	✓	✓	✓	✓	✓
42”(1067mm)		✓	✓	✓	✓
48”(1219mm)				✓	✓
54”(1372mm)				✓	✓
60”(1524mm)				✓	✓

Component Specification Overview

Planes End Supported Top with Column Base

Attached End: Bracket Options

The attached end of the End Supported Top requires separately specified attachment brackets for a structural building wall, Compose or Enclose panel.

5 Specify the appropriate type of attachment bracket and quantity per End Supported Top application. See below for options:

Structural Building Wall Application

- Specify the required quantity to accommodate the depth of the End Supported Top.

Wall Mount Bracket

Bracket Quantity	
Depth of End Supported Top	Number of Brackets Required
36"(914mm)-42"(1067mm)	Quantity: (2)
48"(1219mm)-60"(1524mm)	Quantity: (3)

Compose and/or Enclose Panel Application

- Specify the appropriate side/corner bracket per worktop edge option. One left- and one right-hand bracket is required per Compose or Enclose panel for an attached End Supported Top.

For use with Edgeband trim:

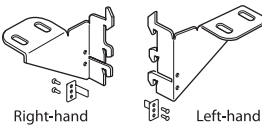

Side/Corner Bracket

For use with Cascade, T-Mold and Knife edge trim options:

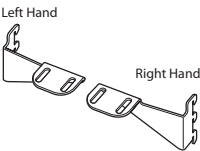

Side Bracket for use with Knife Edge

Planes End Supported Top — D-Shape Convergent (for use with Column Base)

Laminate or Wood

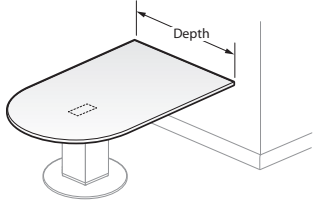

TARD

Features

- Includes 1 3/16" (30mm) thick top.
- Laminate top with knife edge or 3mm edgeband edges or wood veneer top with 3mm wood edgeband or knife edge. Edgeband tops are 3mm on user edge and 1mm on end supported edge.
- **Requires separately specified Column Base for one end and support brackets for opposite end.**
- Optional power modules are separately specified.
- Depth and width shown in nominal dimensions.

Specification Tips

- Each end of top requires separate support components:
One end of top requires separately specified components for Column Base:
 - Column Frame
 - Cladding (4) pieces per each Column Frame
 - Optional Column Base Plate can also be specified
- **Opposite End of top requires support brackets for attachment to the building wall or support brackets for Enclose or Compose.**
- Does not require J Channels.
- Cutouts are optional. If specified they are factory installed.
- Each cutout requires a separately specified flip top unit electrical module or a select workware interface module (see workware price list).
- Separately specified Planes grommets are available for field installation.
- For separately specified required components refer to the **Component Specification Overview** located in the front of the price list; see Planes End Supported Tops (for use with Column Base).

To Order, Specify:

1) Product number, including;

① Surface Options:

- L** Laminate
- W** Wood

② Edge Options:

Laminate:

- J** Edgeband
- F** Knife

Wood:

- K** Wood Edgeband
- U** Knife

③ Cutout Options:

- N** No Cutout
- F** Center, Single-Sided/4 outlets, add **\$33.13** list
- J** Center, Single-Sided/6 outlets, add **\$33.13** list
- M** Center, Double-Sided/8 outlets, add **\$33.13** list
- Q** Center, Double-Sided/12 outlets, add **\$33.13** list

workware Switching:

- C** Center, 4 Port Narrow Switching, add **\$33.13** list
- E** Center, 6 Port Narrow Switching, add **\$33.13** list
- H** Center, 4 Port Wide Switching, add **\$33.13** list
- L** Center, 6 Port Wide Switching, add **\$33.13** list

workware Non-Switching:

- D** Center, 4 Port Narrow Non-Switching, add **\$33.13** list
- W** Center, 4 Port Wide Non-Switching, add **\$33.13** list

2) Laminate surface color or wood finish color.

3) Edge trim color (laminated only).

Planes End Supported Top — D-Shape Convergent (for use with Column Base)

Laminate or Wood

Depth	Width	Number ① ② ③	Laminate A		Laminate B		Wood Group A		Wood Group B	
			J	F	J	F	K	U	K	U
42"(1067mm)	48"(1219mm)	TARD-4248- S BNNN	\$ 605.49	\$ 857.69	\$ 682.64	\$ 934.84	\$1006.41	\$1276.14	\$1104.14	\$1408.90
	54"(1372mm)	TARD-4254- S BNNN	689.07	955.31	775.53	1041.77	1137.53	1435.05	1259.06	1596.05
	60"(1524mm)	TARD-4260- S BNNN	772.65	1052.93	868.42	1148.70	1268.93	1595.80	1414.30	1785.36
	66"(1676mm)	TARD-4266- S BNNN	856.23	1150.55	961.31	1255.63	1400.59	1758.39	1569.87	1976.83
	72"(1829mm)	TARD-4272- S BNNN	939.81	1248.17	1054.20	1362.56	1532.51	1922.83	1725.76	2170.46
48"(1219mm)	48"(1219mm)	TARD-4848- S BNNN	\$ 700.65	\$ 966.89	\$ 788.44	\$1054.68	\$1152.60	\$1437.53	\$1276.76	\$1599.06
	54"(1372mm)	TARD-4854- S BNNN	795.81	1076.09	894.24	1174.52	1301.07	1614.58	1452.13	1807.58
	60"(1524mm)	TARD-4860- S BNNN	890.97	1185.29	1000.04	1294.36	1449.81	1793.46	1627.82	2018.26
	66"(1676mm)	TARD-4866- S BNNN	986.13	1294.49	1105.84	1414.20	1598.81	1974.18	1803.84	2231.10
	72"(1829mm)	TARD-4872- S BNNN	1081.29	1403.69	1211.64	1534.04	1748.08	2156.75	1980.18	2446.10
54"(1372mm)	54"(1372mm)	TARD-5454- S BNNN	\$ 902.55	\$1196.87	\$1012.95	\$1307.27	\$1766.39	\$2211.53	\$1946.97	\$2436.53
	60"(1524mm)	TARD-5460- S BNNN	1009.29	1317.65	1131.66	1440.02	1932.46	2408.54	2143.12	2668.58
	66"(1676mm)	TARD-5466- S BNNN	1116.03	1438.43	1250.37	1572.77	2098.81	2607.39	2339.59	2902.79
	72"(1829mm)	TARD-5472- S BNNN	1222.77	1559.21	1369.08	1705.52	2265.43	2808.09	2536.38	3139.16
60"(1524mm)	60"(1524mm)	TARD-6060- S BNNN	\$1127.61	\$1450.01	\$1263.28	\$1585.68	\$2177.07	\$2701.50	\$2420.37	\$2996.78
	66"(1676mm)	TARD-6066- S BNNN	1245.93	1582.37	1394.90	1731.34	2360.77	2918.48	2637.29	3252.36
	72"(1829mm)	TARD-6072- S BNNN	1364.25	1714.73	1526.52	1877.00	2544.72	3137.31	2854.54	3510.10
	78"(1981mm)	TARD-6078- S BNNN	1482.57	1847.09	1658.14	2022.66	2728.95	3357.97	3072.11	3770.00
	84"(2134mm)	TARD-6084- S BNNN	1600.89	1979.45	1789.76	2168.32	2913.45	3580.48	3290.00	4032.06

*Recommended seating capacity based upon 27"(687mm) per chair.

Planes End Supported Top — Rectangular Conference End (for use with Column Base)

Laminate or Wood

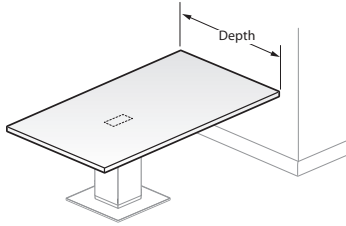

TARU

Features

- Includes 1 3/16" (30mm) thick top.
- Laminate top with knife edge or 3mm edgeband edges or wood veneer top with 3mm wood edgeband or knife edge. Edgeband tops are 3mm on user edge and 1mm on end supported edge.
- **Requires separately specified Column Base for one end and support brackets for opposite end.**
- Optional power modules are separately specified.
- Depth and width shown in nominal dimensions.

Specification Tips

- Each end of top requires separate support components:
 - **One end of top requires separately specified components for Column Base:**
 - Column Frame
 - Cladding (4) pieces per each Column Frame
 - Optional Column Base Plate can also be specified
 - **Opposite End of top requires support brackets for attachment to the building wall or support brackets for Enclose or Compose.**
- Does not require J Channels.
- Cutouts are optional. If specified they are factory installed.
- Each cutout requires a separately specified flip top unit electrical module or a select workware interface module (see workware price list).
- Separately specified Planes grommets are available for field installation.
- For separately specified required components refer to the **Component Specification Overview** located in the front of the price list; see Planes End Supported Tops (for use with Column Base).

To Order, Specify:

1) Product number, including;

① Surface Options:

- L** Laminate
- W** Wood

② Edge Options:

Laminate:

- J** Edgeband
- F** Knife

Wood:

- K** Wood Edgeband
- U** Knife

③ Cutout Options:

- N** No Cutout
- F** Center, Single-Sided/4 outlets, add **\$33.13** list
- J** Center, Single-Sided/6 outlets, add **\$33.13** list
- M** Center, Double-Sided/8 outlets, add **\$33.13** list
- Q** Center, Double-Sided/12 outlets, add **\$33.13** list

workware Switching:

- C** Center, 4 Port Narrow Switching, add **\$33.13** list
- E** Center, 6 Port Narrow Switching, add **\$33.13** list
- H** Center, 4 Port Wide Switching, add **\$33.13** list
- L** Center, 6 Port Wide Switching, add **\$33.13** list

workware Non-Switching:

- D** Center, 4 Port Narrow Non-Switching, add **\$33.13** list
- W** Center, 4 Port Wide Non-Switching, add **\$33.13** list

2) Laminate surface color or wood finish color.

3) Edge trim color (laminate cascade only).

Planes End Supported Top — Rectangular Conference End (for use with Column Base)

Laminate or Wood

Depth	Width	Number ① ② ③	Laminate A		Laminate B		Wood Group A		Wood Group B	
			J	F	J	F	K	U	K	U
36"(914mm)	48"(1219mm)	TARU-3648- S BNNN	\$ 510.33	\$ 748.49	\$ 576.84	\$ 815.00	\$ 860.22	\$1114.74	\$ 931.52	\$1218.74
	54"(1372mm)	TARU-3654- S BNNN	582.33	834.53	656.82	909.02	974.00	1255.52	1065.99	1384.52
	60"(1524mm)	TARU-3660- S BNNN	654.33	920.57	736.80	1003.04	1088.05	1398.14	1200.78	1552.46
	66"(1676mm)	TARU-3666- S BNNN	726.33	1006.61	816.78	1097.06	1202.36	1542.60	1335.89	1722.56
	72"(1829mm)	TARU-3672- S BNNN	798.33	1092.65	896.76	1191.08	1316.95	1688.91	1471.33	1894.82
42"(1067mm)	48"(1219mm)	TARU-4248- S BNNN	\$ 605.49	\$ 857.69	\$ 682.64	\$ 934.84	\$1006.41	\$1276.14	\$1104.14	\$1408.90
	54"(1372mm)	TARU-4254- S BNNN	689.07	955.31	775.53	1041.77	1137.53	1435.05	1259.06	1596.05
	60"(1524mm)	TARU-4260- S BNNN	772.65	1052.93	868.42	1148.70	1268.93	1595.80	1414.30	1785.36
	66"(1676mm)	TARU-4266- S BNNN	856.23	1150.55	961.31	1255.63	1400.59	1758.39	1569.87	1976.83
	72"(1829mm)	TARU-4272- S BNNN	939.81	1248.17	1054.20	1362.56	1532.51	1922.83	1725.76	2170.46
48"(1219mm)	48"(1219mm)	TARU-4848- S BNNN	\$ 700.65	\$ 966.89	\$ 788.44	\$1054.68	\$1152.60	\$1437.53	\$1276.76	\$1599.06
	54"(1372mm)	TARU-4854- S BNNN	795.81	1076.09	894.24	1174.52	1301.07	1614.58	1452.13	1807.58
	60"(1524mm)	TARU-4860- S BNNN	890.97	1185.29	1000.04	1294.36	1449.81	1793.46	1627.82	2018.26
	66"(1676mm)	TARU-4866- S BNNN	986.13	1294.49	1105.84	1414.20	1598.81	1974.18	1803.84	2231.10
	72"(1829mm)	TARU-4872- S BNNN	1081.29	1403.69	1211.64	1534.04	1748.08	2156.75	1980.18	2446.10
54"(1372mm)	54"(1372mm)	TARU-5454- S BNNN	\$ 902.55	\$1196.87	\$1012.95	\$1307.27	\$1766.39	\$2211.53	\$1946.97	\$2436.53
	60"(1524mm)	TARU-5460- S BNNN	1009.29	1317.65	1131.66	1440.02	1932.46	2408.54	2143.12	2668.58
	66"(1676mm)	TARU-5466- S BNNN	1116.03	1438.43	1250.37	1572.77	2098.81	2607.39	2339.59	2902.79
	72"(1829mm)	TARU-5472- S BNNN	1222.77	1559.21	1369.08	1705.52	2265.43	2808.09	2536.38	3139.16
60"(1524mm)	60"(1524mm)	TARU-6060- S BNNN	\$1127.61	\$1450.01	\$1263.28	\$1585.68	\$2177.07	\$2701.50	\$2420.37	\$2996.78
	66"(1676mm)	TARU-6066- S BNNN	1245.93	1582.37	1394.90	1731.34	2360.77	2918.48	2637.29	3252.36
	72"(1829mm)	TARU-6072- S BNNN	1364.25	1714.73	1526.52	1877.00	2544.72	3137.31	2854.54	3510.10
	78"(1981mm)	TARU-6078- S BNNN	1482.57	1847.09	1658.14	2022.66	2728.95	3357.97	3072.11	3770.00
84"(2134mm)	TARU-6084- S BNNN	1600.89	1979.45	1789.76	2168.32	2913.45	3580.48	3290.00	4032.06	

*Recommended seating capacity based upon 27"(687mm) per chair.

Planes End Supported Top — Key Conference (for use with Column Base)

Laminate or Wood

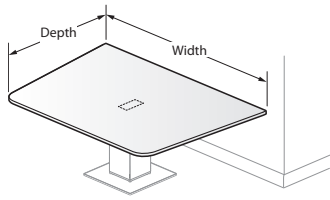

TARY

Features

- Includes 1 3/16" (30mm) thick top.
- Laminate top with knife edge or 3mm edgeband edges or wood veneer top with 3mm wood edgeband or knife edge. Edgeband tops are 3mm on user edge and 1mm on end supported edge.
- **Requires separately specified Column Base for one end and support brackets for opposite end.**
- Optional power modules are separately specified.
- Depth and width shown in nominal dimensions.

Specification Tips

- Each end of top requires separate support components:
 - **One end of top requires separately specified components for Column Base:**
 - Column Frame
 - Cladding (4) pieces per each Column Frame
 - Optional Column Base Plate can also be specified
 - **Opposite End of top requires support brackets for attachment to the building wall or support brackets for Enclose or Compose.**
- Does not require J Channels.
- Cutouts are optional. If specified they are factory installed.
- Each cutout requires a separately specified flip top unit electrical module or a select workware interface module (see workware price list).
- Separately specified Planes grommets are available for field installation.
- For separately specified required components refer to the **Component Specification Overview** located in the front of the price list; see Planes End Supported Tops (for use with Column Base).

To Order, Specify:

1) Product number, including;

① Surface Options:

- L** Laminate
- W** Wood

② Edge Options:

Laminate:

- J** Edgeband
- F** Knife

Wood:

- K** Wood Edgeband
- U** Knife

③ Cutout Options:

- N** No Cutout
- F** Center, Single-Sided/4 outlets, add **\$33.13** list
- J** Center, Single-Sided/6 outlets, add **\$33.13** list
- M** Center, Double-Sided/8 outlets, add **\$33.13** list
- Q** Center, Double-Sided/12 outlets, add **\$33.13** list

workware Switching:

- C** Center, 4 Port Narrow Switching, add **\$33.13** list
- E** Center, 6 Port Narrow Switching, add **\$33.13** list
- H** Center, 4 Port Wide Switching, add **\$33.13** list
- L** Center, 6 Port Wide Switching, add **\$33.13** list

workware Non-Switching:

- D** Center, 4 Port Narrow Non-Switching, add **\$33.13** list
- W** Center, 4 Port Wide Non-Switching, add **\$33.13** list

2) Laminate surface color or wood finish color.

3) Edge trim color (laminate cascade only).

Planes End Supported Top — Key Conference (for use with Column Base)

Laminate or Wood

Depth	Width	Number ① ② ③	Laminate A		Laminate B		Wood Group A		Wood Group B	
			J	F	J	F	K	U	K	U
42"(1067mm)	42"(1067mm)	TARY-4242- S BNNN	\$ 521.91	\$ 760.07	\$ 589.75	\$ 827.91	\$ 875.55	\$1119.06	\$ 949.55	\$1223.91
	48"(1219mm)	TARY-4248- S BNNN	605.49	857.69	682.64	934.84	1006.41	1276.14	1104.14	1408.90
	54"(1372mm)	TARY-4254- S BNNN	689.07	955.31	775.53	1041.77	1137.53	1435.05	1259.06	1596.05
	60"(1524mm)	TARY-4260- S BNNN	772.65	1052.93	868.42	1148.70	1268.93	1595.80	1414.30	1785.36
48"(1219mm)	48"(1219mm)	TARY-4848- S BNNN	\$ 700.65	\$ 966.89	\$ 788.44	\$1054.68	\$1152.60	\$1437.53	\$1276.76	\$1599.06
	54"(1372mm)	TARY-4854- S BNNN	795.81	1076.09	894.24	1174.52	1301.07	1614.58	1452.13	1807.58
	60"(1524mm)	TARY-4860- S BNNN	890.97	1185.29	1000.04	1294.36	1449.81	1793.46	1627.82	2018.26
	66"(1676mm)	TARY-4866- S BNNN	986.13	1294.49	1105.84	1414.20	1598.81	1974.18	1803.84	2231.10
	72"(1829mm)	TARY-4872- S BNNN	1081.29	1403.69	1211.64	1534.04	1748.08	2156.75	1980.18	2446.10
54"(1372mm)	54"(1372mm)	TARY-5454- S BNNN	\$ 902.55	\$1196.87	\$1012.95	\$1307.27	\$1766.39	\$2211.53	\$1946.97	\$2436.53
	60"(1524mm)	TARY-5460- S BNNN	1009.29	1317.65	1131.66	1440.02	1932.46	2408.54	2143.12	2668.58
	66"(1676mm)	TARY-5466- S BNNN	1116.03	1438.43	1250.37	1572.77	2098.81	2607.39	2339.59	2902.79
	72"(1829mm)	TARY-5472- S BNNN	1222.77	1559.21	1369.08	1705.52	2265.43	2808.09	2536.38	3139.16
60"(1524mm)	60"(1524mm)	TARY-6060- S BNNN	\$1127.61	\$1450.01	\$1263.28	\$1585.68	\$2177.07	\$2701.50	\$2420.37	\$2996.78
	66"(1676mm)	TARY-6066- S BNNN	1245.93	1582.37	1394.90	1731.34	2360.77	2918.48	2637.29	3252.36
	72"(1829mm)	TARY-6072- S BNNN	1364.25	1714.73	1526.52	1877.00	2544.72	3137.31	2854.54	3510.10
	78"(1981mm)	TARY-6078- S BNNN	1482.57	1847.09	1658.14	2022.66	2728.95	3357.97	3072.11	3770.00
	84"(2134mm)	TARY-6084- S BNNN	1600.89	1979.45	1789.76	2168.32	2913.45	3580.48	3290.00	4032.06

*Recommended seating capacity based upon 27"(687mm) per chair.

Planes End Supported Top (for use with Column Base) — Bracket(s)

	Description	Number	Price
Wall Mount Bracket(s)	Single	ZUBW-0000-PN	\$26.58



ZUBW-0000-PN

Features

- Includes one wall mount bracket and attachment hardware to top.
- Screws/anchors for attachment to wall are field supplied.
- Supports one end of a Planes End Supported Top.
- Standard in black finish only.

To Order, Specify:

- 1) Product number.
(No finish specification required.)

Specification Tips

- Supports the straight end of an End Supported Top in a wall mount application. Opposite end of top requires a column base.
- Number of brackets required is dependent on depth of the End Supported Top; see chart for quantity.
- Must be properly anchored to a structural wall.

Wall Mount Bracket Requirement:

Width of End Supported Top	Number of Brackets Required
36"-42"	Quantity: (2)
48"-60"	Quantity: (3)

Side/Corner Bracket

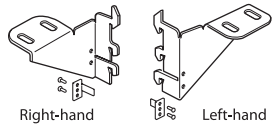

Right-hand
ZZBA-0000-PR
ZZBA-0000-PL

Left-hand

Description	Number	Price
Right-hand	ZZBA-0000-PR	\$21.74
Left-hand	ZZBA-0000-PL	\$21.74

Features

- Includes one left- or right-hand bracket, mounting screws and dislodgement clip.
- Standard in charcoal finish.
- Installs into Compose or Enclose panel frame slots and attaches to top.
- For use with Edgeband trim only.

To Order, Specify:

- 1) Product number.
(No finish specification required.)

Specification Tips

- Supports the straight end of an End Supported Top in a Compose or Enclose panel mount application. Opposite end of top requires a column base.
- A left- and right-hand bracket is required for one End Supported Top.

Side Bracket for use with Knife Edge

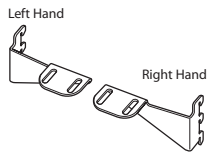

Left Hand
ZZBA-0000-PRF
ZZBA-0000-PLF

Right Hand

Right-hand	ZZBA-0000-PRF	\$64.23
Left-hand	ZZBA-0000-PLF	\$64.23

Features

- Includes one left- or right-hand bracket, mounting screws and dislodgement clip.
- Installs into Compose or Enclose panel frame slots and attaches to top.
- For use with Knife Edge, Cascade and T-Mold trim options.

To Order, Specify:

- 1) Product number.
- 2) Trim color.

Note: \$17.29 upcharge list for Metallic and accent trim colors.

Specification Tips

- Supports the straight end of an End Supported Top in a Compose or Enclose panel mount application. Opposite end of top requires a column base.
- A left- and right-hand bracket is required for one End Supported Top with Knife edge trim option, only.

Planes — Accessories

	Height	Depth	Width	Number	Laminate A	B	Wood Group A	Group B
Cable Base	Laminate							
	28"(711mm)	8"(203mm)	14"(356mm)	TA01-0814-L	\$658.77	\$711.61		
		14"(356mm)	14"(356mm)	TA01-1414-L	701.75	758.23		
	Wood							
	28"(711mm)	8"(203mm)	14"(356mm)	TA01-0814-W			\$1113.53	\$1146.72
		14"(356mm)	14"(356mm)	TA01-1414-W			1189.27	1239.61

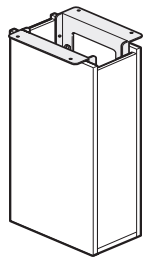

TA01-0814

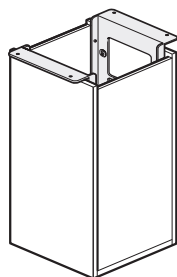

TA01-1414

Features

- Includes 28"(711mm) high cable base and mounting hardware.
- Laminate with 1mm edgeband or wood veneer with 1mm wood edgeband.
- Provides internal cable management with removable panels for access.
- Standard in green core.
- Bracket is standard in charcoal.
- Includes 1"(25mm) adjustable glides.
- Ships assembled.

To Order, Specify:

- 1) Product number.
- 2) Laminate surface color or wood finish color.
- 3) Edge trim color for laminate.

Specification Tips

- Refer to Specification Guide for use guidelines.
- **Cable base not recommended for use with 30"(762mm) deep tables, half round tables, polygon tables or Y-leg tables or 36"(914mm) deep tables with (M) or (Q) flip top unit cutout options.**
- Specify 8"(203mm) x 14"(356mm) cable base for 36"(914mm) deep tables.
- Specify 14"(356mm) x 14"(356mm) cable base for 42"(1067mm) deep and deeper tables.
- One and two-piece table tops – one cable base.
- Three-piece table tops – two cable bases.
- Cable base cord access:
 - 1 1/2"(38mm) at top
 - adjustable side panels allow 1"(25mm) gap at bottom edges
 - 8"(203mm) depth base has a 3"(76mm) deep cutout in bottom;
 - 14"(356mm) depth base has an 8"(203mm) deep cutout in bottom.

The following Planes products are separately specified:

- Horizontal wire management

	Height	Depth	Width	Number	Price
Cable Column	28"(711mm)	2"(51mm)	4 1/2"(114mm)	TA01-0217	\$239.14



TA01-0217

Features

- Cable Column offers a wire management option for conference tables when the Cable Base Option cannot be used.
- Includes one Cable Column with mounting hardware for attaching to underside of table.
- Hardware for attaching Cable Column to floor is field supplied.
- Ships unassembled.



To Order, Specify:

- 1) Product number.
- 2) Trim color.

Specification Tips

- Cable Column attaches to underside of table, extends to the floor where it is also attached.
- Cable Column is not load bearing and does not replace table leg(s).
- Cable Column can be installed anywhere under a conference table unless it would interfere with table legs, Horizontal Wire Manager or Flip Top Power/Data Units.
- The Cable Column can be used with the Horizontal Wire Manager for cable management.

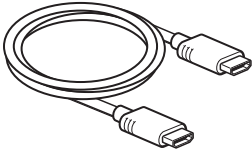
Planes — Accessories

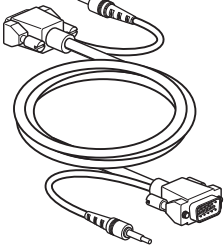
	Length	Description	Number	Price
 <p>EWCX-H</p>  <p>EWCX-5001-H</p>  <p>EWCX-V</p>	HDMI or VGA Cable			
	3'(914mm)	HDMI – male/male	EWCX-0301-H	\$ 96.03
	6'(1829mm)	HDMI – male/male	EWCX-0601-H	128.05
	10'(3048mm)	HDMI – male/male	EWCX-1001-H	138.71
	15'(4572mm)	HDMI – male/male	EWCX-1501-H	200.78
	25'(7620mm)	HDMI – male/male	EWCX-2501-H	324.95
	50'(15240mm)	HDMI – male/male	EWCX-5001-H	450.20
	5'(1524mm)	VGA + Audio – male/male	EWCX-0501-V	\$137.18
	10'(3048mm)	VGA + Audio – male/male	EWCX-1001-V	160.88
	15'(4572mm)	VGA + Audio – male/male	EWCX-1501-V	220.63
	25'(7620mm)	VGA + Audio – male/male	EWCX-2501-V	280.60
	50'(15240mm)	VGA – male/male	EWCX-5001-V	400.31

Features

- Includes one black HDMI or VGA/VGA + Audio cable.
- For use with:
 - HDMI transmits digital video and audio signals.
 - VGA + Audio transmits analog video and audio signals with the exception of the 50' cable.

To Order, Specify:

- 1) Product number.
(No finish specification required.)

Specification Tips

- Provides communication between components: i.e. laptop, processor, monitor, etc.
 - Daisy chaining of cables not recommended.**
 - The audio cable extension of the user VGA + Audio cable extends 20" from the connector head. Separately specify audio only cables if audio extension is not long enough for application.
- 50' VGA cable not available with audio.

Planes — Electrical Accessories

	Description	Extension Length	Number	Price
Cable Reel	60"(1524mm) HDMI	48"(1219mm)	TA01-CR48-H	\$668.43
	60"(1524mm) VGA	48"(1219mm)	TA01-CR48-V	668.43

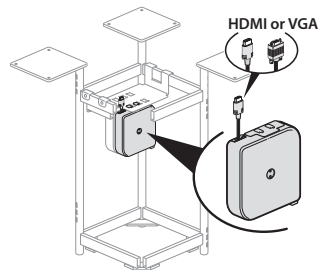

TA01-CR48

Features

- Includes cable reel with spring loaded retractor mechanism with one cable which can extend 48"(1219mm).
- Cable Reel available with one VGA or one HDMI cable.
- VGA Cable Reel has female VGA connector on housing for connection of VGA patch cable.
- HDMI Cable Reel has female HDMI connector on housing for connection of HDMI patch cable.
- VGA or HDMI patch cable typically routes to TV Monitor or workware video processor.
- VGA cable conveys video only - no audio content.
- Black only.

To Order, Specify:

- 1) Product number.
(No finish specification required.)

Specification Tips

- For use with cable reel bracket, column frame and power modules equipped with cable bay(s), seated, standing or lounge height column frame.
- Separately specify cable reel bracket.
- VGA or HDMI Cable required to route from cable reel to TV monitor or workware video processor.
- Cable reels compatible with the following power modules specified with cable bay(s):
 - workware interface
 - flip top power module
 - flush mount power module

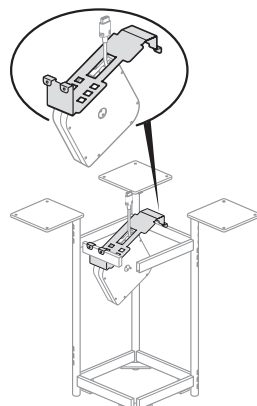
Cable Reel Bracket

TA01-CRBK

Description	Number	Price
9"(229mm)	TA01-CRBK-T09	\$44.56
12"(305mm)	TA01-CRBK-T12	44.56

Features

- Includes bracket and mounting hardware to mount cable reels to column frame.
- 9"(229mm) cable reel bracket for use with 9"(229mm) column frame and allows mounting of up to two cable reels.
- 12"(305mm) cable reel bracket for use with 12"(305mm) column frame and allows mounting of up to four cable reels.
- Available in black only.

To Order, Specify:

- 1) Product number.
(No finish specification required.)

Specification Tips

- For use with 9"(229mm) or 12"(305mm) base frames, seated, standing or lounge heights.
- Specify VGA or HDMI cable reels separately.
- Specify column frame, cladding, power module and table separately.

Planes — Electrical Accessories

	Height	Number	Price
Cable Management Processor Bracket	21"(533mm)	TA01-PB21	\$44.56

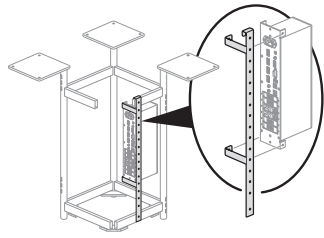

TA01-PB21

Features

- Includes mounting hardware to mount workware processor or cable management products to column frame.
- Provides multiple mounting holes for attaching cable ties or other cable management products.
- Available in black only.

Specification Tips

- For use with 9"(229mm) or 12"(305mm) column frame and power modules equipped with cable bay(s).
- For use with seated and standing height column frame.
- Not required for use with Cable Retractor (workware processor mounts to Cable Retractor).
- Recommend for use with Cable Reels and workware Processor.
- Not for use with lounge height column frame.

To Order, Specify:

- 1) Product number.
(No finish specification required.)

Cable Base Cable Retractor	Description	Width	Length	Number	Price
	2 Cable Chute	4 1/2"(114mm)	22"(559mm)	EWCX-BRWM-2A	\$378.91
	4 Cable Chute	7 1/2"(191mm)	22"(559mm)	EWCX-BRWM-4A	588.15

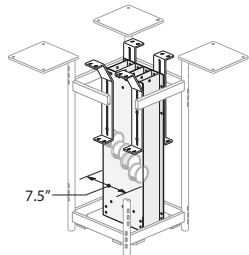
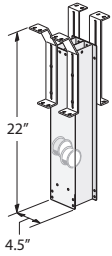

EWCX-BRWM

Features

- Includes chute, weights and mounting hardware.
- Installs on the underside of the table top.
- For use with separately ordered Cable Base, Column Base, workware Interface Module, Flip Top Unit or Flush Mount Power Module to retract cables from table top.
- Provides 34"(864mm) of cable travel.
- Provides vertical cable management within the Column Base.
- Isolates user cables from other data and power connection cables within the Column Base.

Specification Tips

- Order Cable Base, Column Base, cables and workware Interface Module separately.
- One cable per chute.
- Requires 1/4"(6mm) diameter cables or less.
- workware processor can be mounted to the side of the chute when used with 9" x 9"(229mm x 229mm) or 12" x 12"(305mm x 305mm) column base.
- For use with seated or standing height Column Base.
- Not for use with lounge height Column Base.
- 2 cable chute fits in 9" x 9"(229mm x 229mm) or 12" x 12"(305mm x 305mm) Column Base.
- 4 cable chute fits in 12" x 12"(305mm x 305mm) Column Base.

To Order, Specify:

- 1) Product number.
(No finish specification required.)

PopUp Tables

This page intentionally blank

PopUp Tables General Specifications

General Guidelines for Product Specification

EXAMPLE: PopUp Table, Rectangle, 18" x 48", Laminate, Edgeband, 1 3/16" Core, No Cutout, Angled Leg, Glide, 36"H, Foot Rest.

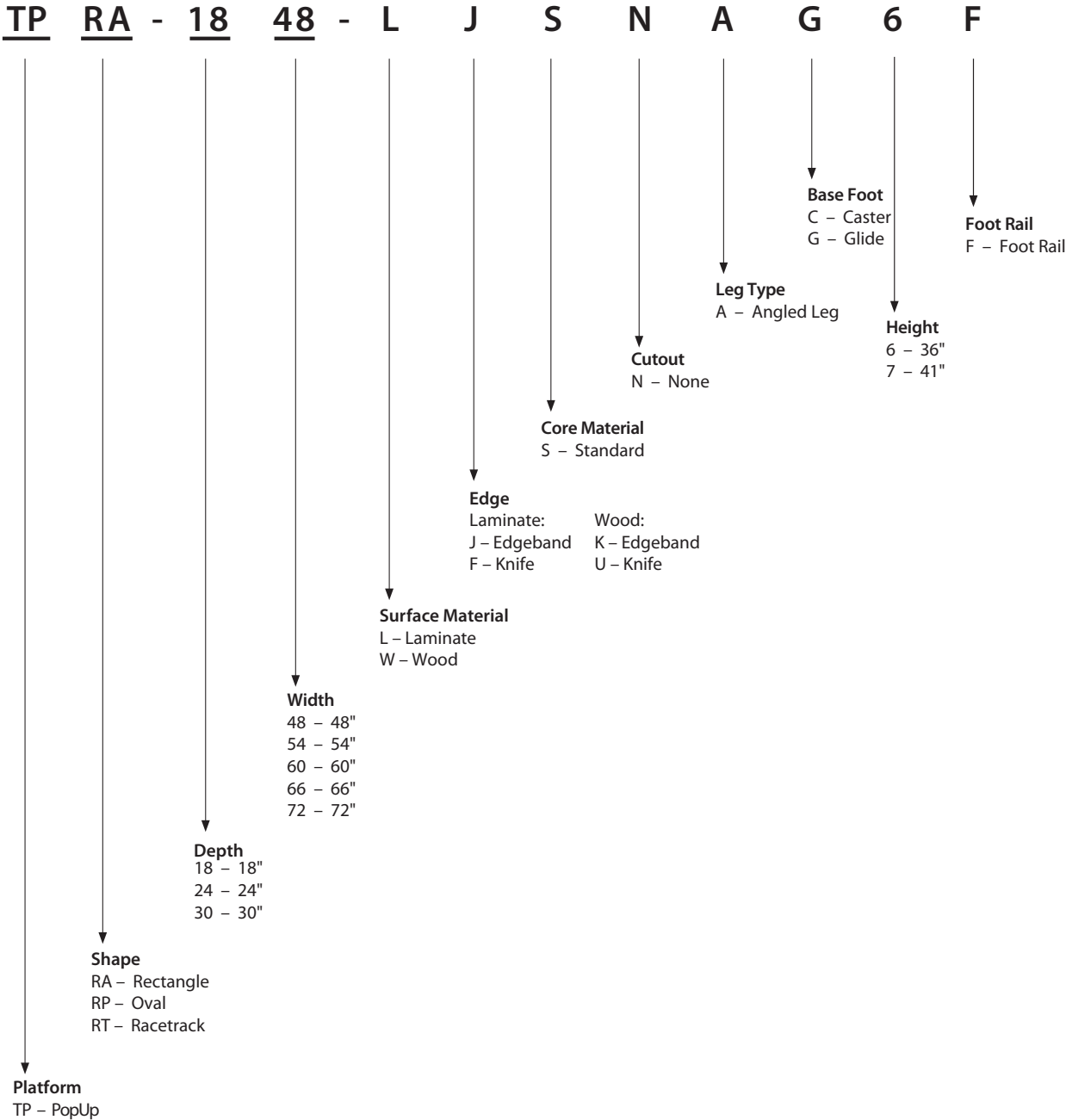

PopUp Table

Rectangle – Laminate or Wood

Height	Depth	Width	Number	① ② ③	Laminate A		Laminate B		Wood Group A		Wood Group B		
					J	F	J	F	K	U	K	U	
36"(914mm)	18"(457mm)	48"(1219mm)	TPRA-1848-	SNA	6F	\$1246.85	\$1502.77	\$1350.44	\$1606.36	\$1554.69	\$1865.73	\$1617.13	\$1928.17
		54"(1372mm)	TPRA-1854-	SNA	6F	1273.67	1558.75	1378.97	1664.05	1597.11	1929.51	1666.15	1998.55
		60"(1524mm)	TPRA-1860-	SNA	6F	1300.49	1614.73	1407.50	1721.74	1639.53	1993.29	1715.17	2068.93
		66"(1676mm)	TPRA-1866-	SNA	6F	1327.31	1670.71	1436.03	1779.43	1681.95	2057.07	1764.19	2139.31
		72"(1829mm)	TPRA-1872-	SNA	6F	1354.13	1726.69	1464.56	1837.12	1724.37	2120.85	1813.21	2209.69
24"(610mm)	48"(1219mm)	48"(1219mm)	TPRA-2448-	SNA	6F	\$1306.93	\$1581.21	\$1415.08	\$1689.36	\$1656.37	\$1980.49	\$1736.41	\$2060.53
		54"(1372mm)	TPRA-2454-	SNA	6F	1340.93	1644.37	1451.36	1754.80	1711.17	2056.65	1800.01	2145.49
		60"(1524mm)	TPRA-2460-	SNA	6F	1374.93	1707.53	1487.64	1820.24	1765.97	2132.81	1863.61	2230.45
		66"(1676mm)	TPRA-2466-	SNA	6F	1408.93	1770.69	1523.92	1885.68	1820.77	2208.97	1927.21	2315.41
		72"(1829mm)	TPRA-2472-	SNA	6F	1442.93	1833.85	1560.20	1951.12	1875.57	2285.13	1990.81	2400.37
30"(762mm)	48"(1219mm)	48"(1219mm)	TPRA-3048-	SNA	6F	\$1367.01	\$1659.65	\$1479.72	\$1772.36	\$1758.05	\$2095.25	\$1855.69	\$2192.89
		54"(1372mm)	TPRA-3054-	SNA	6F	1408.19	1729.99	1523.75	1845.55	1825.23	2183.79	1933.87	2292.43
		60"(1524mm)	TPRA-3060-	SNA	6F	1449.37	1800.33	1567.78	1918.74	1892.41	2272.33	2012.05	2391.97
		66"(1676mm)	TPRA-3066-	SNA	6F	1490.55	1870.67	1611.81	1991.93	1959.59	2360.87	2090.23	2491.51
		72"(1829mm)	TPRA-3072-	SNA	6F	1531.73	1941.01	1655.84	2065.12	2026.77	2449.41	2168.41	2591.05
41"(1041mm)	18"(457mm)	48"(1219mm)	TPRA-1848-	SNA	7F	\$1276.80	\$1532.72	\$1380.39	\$1636.31	\$1584.64	\$1895.68	\$1647.08	\$1958.12
		54"(1372mm)	TPRA-1854-	SNA	7F	1303.62	1588.70	1408.92	1694.00	1627.06	1959.46	1696.10	2028.50
		60"(1524mm)	TPRA-1860-	SNA	7F	1330.44	1644.68	1437.45	1751.69	1669.48	2023.24	1745.12	2098.88
		66"(1676mm)	TPRA-1866-	SNA	7F	1357.26	1700.66	1465.98	1809.38	1711.90	2087.02	1794.14	2169.26
		72"(1829mm)	TPRA-1872-	SNA	7F	1384.08	1756.64	1494.51	1867.07	1754.32	2150.80	1843.16	2239.64
24"(610mm)	48"(1219mm)	48"(1219mm)	TPRA-2448-	SNA	7F	\$1336.88	\$1611.16	\$1445.03	\$1719.31	\$1686.32	\$2010.44	\$1766.36	\$2090.48
		54"(1372mm)	TPRA-2454-	SNA	7F	1370.88	1674.32	1481.31	1784.75	1741.12	2086.60	1829.96	2175.44
		60"(1524mm)	TPRA-2460-	SNA	7F	1404.88	1737.48	1517.59	1850.19	1795.92	2162.76	1893.56	2260.40
		66"(1676mm)	TPRA-2466-	SNA	7F	1438.88	1800.64	1553.87	1915.63	1850.72	2238.92	1957.16	2345.36
		72"(1829mm)	TPRA-2472-	SNA	7F	1472.88	1863.80	1590.15	1981.07	1905.52	2315.08	2020.76	2430.32
30"(762mm)	48"(1219mm)	48"(1219mm)	TPRA-3048-	SNA	7F	\$1396.96	\$1689.60	\$1509.67	\$1802.31	\$1788.00	\$2125.20	\$1885.64	\$2222.84
		54"(1372mm)	TPRA-3054-	SNA	7F	1438.14	1759.94	1553.70	1875.50	1855.18	2213.74	1963.82	2322.38
		60"(1524mm)	TPRA-3060-	SNA	7F	1479.32	1830.28	1597.73	1948.69	1922.36	2302.28	2042.00	2421.92
		66"(1676mm)	TPRA-3066-	SNA	7F	1520.50	1900.62	1641.76	2021.88	1989.54	2390.82	2120.18	2521.46
		72"(1829mm)	TPRA-3072-	SNA	7F	1561.68	1970.96	1685.79	2095.07	2056.72	2479.36	2198.36	2621.00

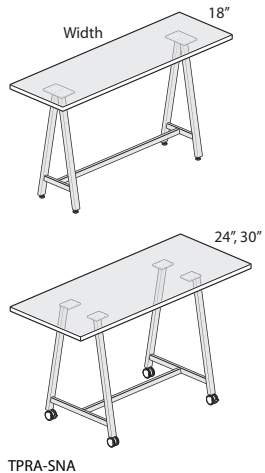

TPRA-SNA

Features

- Includes 1 3/16"(30mm) thick standard top, legs and hardware.
- Laminate top with knife edge or 3mm edgeband edges or wood veneer top with 3mm wood edgeband or knife edge.
- Fixed table heights are 36"(914mm) and 41"(1041mm).
- Casters (two locking/two non-locking) are available with: Light platinum or fog hub with graphite tread, or black hub with black tread.
- Glides available in black only and provide 1/2"(13mm) adjustment.
- Casters and glides are not interchangeable.
- Leg and foot rail can be the same or different trim colors.
- Ships unassembled.

Specification Tips

- Not for use with screens, modesty, AKP, monitor arms or suspended pedestal.
- Separately specified, as needed:
 - Power modules
 - Vertical Wire Channel (TPVW)
 - Accent Plate (TPAP)
 - Bag Hook (KUWH)

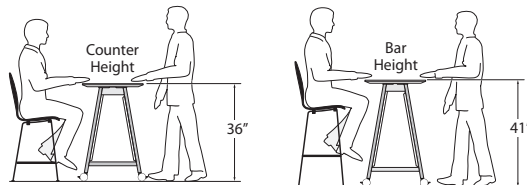

To Order, Specify:

1) Product number, including:

- ① **Surface Option:**
- L** Laminate
 - W** Wood

- ② **Edge Option:**
- Laminate:
- J** Edgeband
 - F** Knife
- Wood:
- K** Edgeband
 - U** Knife

- ③ **Base Foot:**
- C** Casters, add **\$74.88** list
 - G** Glides

- 2) Laminate surface color or wood finish color.
- 3) Edgeband trim color (laminate only).
- 4) Leg trim color.
- 5) Foot rail color.
- 6) Caster color (if applicable).

Note: Foot rail: **\$10.40** upcharge list for Metallic and Accent trim colors.
 Legs: **\$31.20** upcharge list for Metallic and Accent trim colors.

PopUp Table

Oval (Rectangular Radius Corner) – Laminate or Wood

Height	Depth	Width	Number	① ② ③	Laminate A		Laminate B		Wood Group A		Wood Group B		
					J	F	J	F	K	U	K	U	
36"(914mm)	18"(457mm)	48"(1219mm)	TPRP-1848-	SNA	6F	\$1347.73	\$1603.65	\$1451.32	\$1707.24	\$1655.57	\$1966.61	\$1718.01	\$2029.05
		54"(1372mm)	TPRP-1854-	SNA	6F	1374.55	1659.63	1479.85	1764.93	1697.99	2030.39	1767.03	2099.43
		60"(1524mm)	TPRP-1860-	SNA	6F	1401.37	1715.61	1508.38	1822.62	1740.41	2094.17	1816.05	2169.81
		66"(1676mm)	TPRP-1866-	SNA	6F	1428.19	1771.59	1536.91	1880.31	1782.83	2157.95	1865.07	2240.19
		72"(1829mm)	TPRP-1872-	SNA	6F	1455.01	1827.57	1565.44	1938.00	1825.25	2221.73	1914.09	2310.57
24"(610mm)	48"(1219mm)	TPRP-2448-	SNA	6F	\$1407.81	\$1682.09	\$1515.96	\$1790.24	\$1757.25	\$2081.37	\$1837.29	\$2161.41	
		TPRP-2454-	SNA	6F	1441.81	1745.25	1552.24	1855.68	1812.05	2157.53	1900.89	2246.37	
		TPRP-2460-	SNA	6F	1475.81	1808.41	1588.52	1921.12	1866.85	2233.69	1964.49	2331.33	
		TPRP-2466-	SNA	6F	1509.81	1871.57	1624.80	1986.56	1921.65	2309.85	2028.09	2416.29	
		TPRP-2472-	SNA	6F	1543.81	1934.73	1661.08	2052.00	1976.45	2386.01	2091.69	2501.25	
30"(762mm)	48"(1219mm)	TPRP-3048-	SNA	6F	\$1467.89	\$1760.53	\$1580.60	\$1873.24	\$1858.93	\$2196.13	\$1956.57	\$2293.77	
		TPRP-3054-	SNA	6F	1509.07	1830.87	1624.63	1946.43	1926.11	2284.67	2034.75	2393.31	
		TPRP-3060-	SNA	6F	1550.25	1901.21	1668.66	2019.62	1993.29	2373.21	2112.93	2492.85	
		TPRP-3066-	SNA	6F	1591.43	1971.55	1712.69	2092.81	2060.47	2461.75	2191.11	2592.39	
		TPRP-3072-	SNA	6F	1632.61	2041.89	1756.72	2166.00	2127.65	2550.29	2269.29	2691.93	
41"(1041mm)	18"(457mm)	TPRP-1848-	SNA	7F	\$1377.68	\$1633.60	\$1481.27	\$1737.19	\$1685.52	\$1996.56	\$1747.96	\$2059.00	
		TPRP-1854-	SNA	7F	1404.50	1689.58	1509.80	1794.88	1727.94	2060.34	1796.98	2129.38	
		TPRP-1860-	SNA	7F	1431.32	1745.56	1538.33	1852.57	1770.36	2124.12	1846.00	2199.76	
		TPRP-1866-	SNA	7F	1458.14	1801.54	1566.86	1910.26	1812.78	2187.90	1895.02	2270.14	
		TPRP-1872-	SNA	7F	1484.96	1857.52	1595.39	1967.95	1855.20	2251.68	1944.04	2340.52	
24"(610mm)	48"(1219mm)	TPRP-2448-	SNA	7F	\$1437.76	\$1712.04	\$1545.91	\$1820.19	\$1787.20	\$2111.32	\$1867.24	\$2191.36	
		TPRP-2454-	SNA	7F	1471.76	1775.20	1582.19	1885.63	1842.00	2187.48	1930.84	2276.32	
		TPRP-2460-	SNA	7F	1505.76	1838.36	1618.47	1951.07	1896.80	2263.64	1994.44	2361.28	
		TPRP-2466-	SNA	7F	1539.76	1901.52	1654.75	2016.51	1951.60	2339.80	2058.04	2446.24	
		TPRP-2472-	SNA	7F	1573.76	1964.68	1691.03	2081.95	2006.40	2415.96	2121.64	2531.20	
30"(762mm)	48"(1219mm)	TPRP-3048-	SNA	7F	\$1497.84	\$1790.48	\$1610.55	\$1903.19	\$1888.88	\$2226.08	\$1986.52	\$2323.72	
		TPRP-3054-	SNA	7F	1539.02	1860.82	1654.58	1976.38	1956.06	2314.62	2064.70	2423.26	
		TPRP-3060-	SNA	7F	1580.20	1931.16	1698.61	2049.57	2023.24	2403.16	2142.88	2522.80	
		TPRP-3066-	SNA	7F	1621.38	2001.50	1742.64	2122.76	2090.42	2491.70	2221.06	2622.34	
		TPRP-3072-	SNA	7F	1662.56	2071.84	1786.67	2195.95	2157.60	2580.24	2299.24	2721.88	

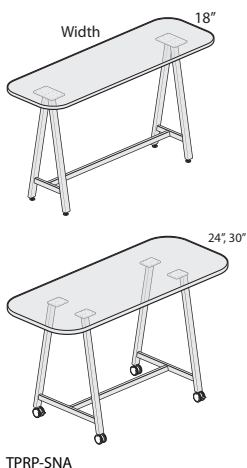

Features

- Includes 1 3/16"(30mm) thick standard top, legs and hardware.
- Laminate top with knife edge or 3mm edgeband edges or wood veneer top with 3mm wood edgeband or knife edge.
- Fixed table heights are 36"(914mm) and 41"(1041mm).
- Casters (two locking/two non-locking) are available with: Light platinum or fog hub with black tread, or black hub with black tread.
- Glides available in black only and provide 1/2"(13mm) adjustment.
- Casters and glides are not interchangeable.
- Leg and foot rail can be the same or different trim colors.
- Ships unassembled.

Specification Tips

- Not for use with screens, modesty, AKP, monitor arms or suspended pedestal.
- Separately specified, as needed:
 - Power modules
 - Vertical Wire Channel (TPVW)
 - Accent Plate (TPAP)
 - Bag Hook (KUWH)

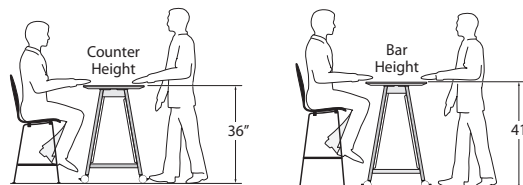

To Order, Specify:

- 1) Product number, including:

① Surface Option:

- L** Laminate
- W** Wood

② Edge Option:

Laminate:

- J** Edgeband
- F** Knife

Wood:

- K** Edgeband
- U** Knife

③ Base Foot:

- C** Casters, add **\$74.88** list
- G** Glides

- 2) Laminate surface color or wood finish color.
- 3) Edgeband trim color (laminates only).
- 4) Leg trim color.
- 5) Foot rail color.
- 6) Caster color (if applicable).

Note: Foot rail: **\$10.40** upcharge list for Metallic and Accent trim colors.
Legs: **\$31.20** upcharge list for Metallic and Accent trim colors.

PopUp Table

Racetrack – Laminate or Wood

Height	Depth	Width	Number	① ② ③	Laminate A		Laminate B		Wood Group A		Wood Group B		
					J	F	J	F	K	U	K	U	
36"(914mm)	18"(457mm)	48"(1219mm)	TPRT-1848-	SNA	6F	\$1347.73	\$1603.65	\$1451.32	\$1707.24	\$1655.57	\$1966.61	\$1718.01	\$2029.05
		54"(1372mm)	TPRT-1854-	SNA	6F	1374.55	1659.63	1479.85	1764.93	1697.99	2030.39	1767.03	2099.43
		60"(1524mm)	TPRT-1860-	SNA	6F	1401.37	1715.61	1508.38	1822.62	1740.41	2094.17	1816.05	2169.81
		66"(1676mm)	TPRT-1866-	SNA	6F	1428.19	1771.59	1536.91	1880.31	1782.83	2157.95	1865.07	2240.19
		72"(1829mm)	TPRT-1872-	SNA	6F	1455.01	1827.57	1565.44	1938.00	1825.25	2221.73	1914.09	2310.57
24"(610mm)	60"(1524mm)	TPRT-2460-	SNA	6F	\$1475.81	\$1808.41	\$1588.52	\$1921.12	\$1866.85	\$2233.69	\$1964.49	\$2331.33	
		TPRT-2466-	SNA	6F	1509.81	1871.57	1624.80	1986.56	1921.65	2309.85	2028.09	2416.29	
		TPRT-2472-	SNA	6F	1543.81	1934.73	1661.08	2052.00	1976.45	2386.01	2091.69	2501.25	
30"(762mm)	72"(1829mm)	TPRT-3072-	SNA	6F	\$1632.61	\$2041.89	\$1756.72	\$2166.00	\$2127.65	\$2550.29	\$2269.29	\$2691.93	
41"(1041mm)	18"(457mm)	48"(1219mm)	TPRT-1848-	SNA	7F	\$1377.68	\$1633.60	\$1481.27	\$1737.19	\$1685.52	\$1996.56	\$1747.96	\$2059.00
		54"(1372mm)	TPRT-1854-	SNA	7F	1404.50	1689.58	1509.80	1794.88	1727.94	2060.34	1796.98	2129.38
		60"(1524mm)	TPRT-1860-	SNA	7F	1431.32	1745.56	1538.33	1852.57	1770.36	2124.12	1846.00	2199.76
		66"(1676mm)	TPRT-1866-	SNA	7F	1458.14	1801.54	1566.86	1910.26	1812.78	2187.90	1895.02	2270.14
		72"(1829mm)	TPRT-1872-	SNA	7F	1484.96	1857.52	1595.39	1967.95	1855.20	2251.68	1944.04	2340.52
24"(610mm)	60"(1524mm)	TPRT-2460-	SNA	7F	\$1505.76	\$1838.36	\$1618.47	\$1951.07	\$1896.80	\$2263.64	\$1994.44	\$2361.28	
		TPRT-2466-	SNA	7F	1539.76	1901.52	1654.75	2016.51	1951.60	2339.80	2058.04	2446.24	
		TPRT-2472-	SNA	7F	1573.76	1964.68	1691.03	2081.95	2006.40	2415.96	2121.64	2531.20	
30"(762mm)	72"(1829mm)	TPRT-3072-	SNA	7F	\$1662.56	\$2071.84	\$1786.67	\$2195.95	\$2157.60	\$2580.24	\$2299.24	\$2721.88	

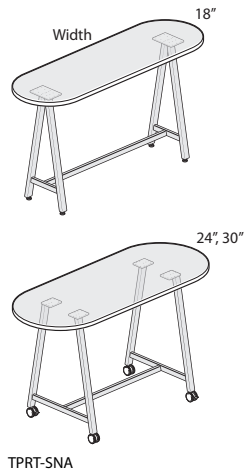

Features

- Includes 1 3/16"(30mm) thick standard top, legs and hardware.
- Laminate top with knife edge or 3mm edgeband edges or wood veneer top with 3mm wood edgeband or knife edge.
- Fixed table heights are 36"(914mm) and 41"(1041mm).
- Casters (two locking/two non-locking) are available with: Light platinum or fog hub with graphite tread, or black hub with black tread.
- Glides available in black only and provide 1/2"(13mm) adjustment.
- Casters and glides are not interchangeable.
- Leg and foot rail can be the same or different trim colors.
- Ships unassembled.

Specification Tips

- Not for use with screens, modesty, AKP, monitor arms or suspended pedestal.
- Separately specified, as needed:
 - Power modules
 - Vertical Wire Channel (TPVW)
 - Accent Plate (TPAP)
 - Bag Hook (KUWH)

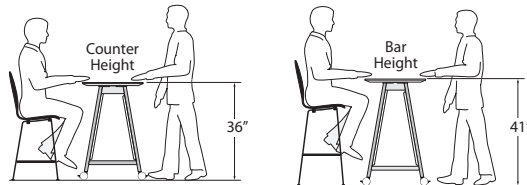

To Order, Specify:

- 1) Product number, including:

① Surface Option:

- L Laminate
- W Wood

② Edge Option:

Laminate:

- J Edgeband
- F Knife

Wood:

- K Edgeband
- U Knife

③ Base Foot:

- C Casters, add \$74.88 list
- G Glides

- 2) Laminate surface color or wood finish color.
- 3) Edgeband trim color (laminate only).
- 4) Leg trim color.
- 5) Foot rail color.
- 6) Caster color (if applicable).

Note: Foot rail: \$10.40 upcharge list for Metallic and Accent trim colors.
 Legs: \$31.20 upcharge list for Metallic and Accent trim colors.

PopUp Table

Accent Plate

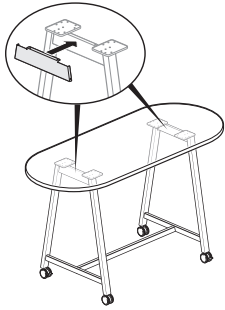

TPAP

Depth	Height	Number ①	Trim A	B	Wood Group A	Group B
24"(610mm)	36"(914mm)	TPAP-2436-	\$218.44	\$224.84	\$322.44	\$342.81
	41"(1041mm)	TPAP-2441-	218.44	224.84	322.44	342.81
30"(762mm)	36"(914mm)	TPAP-3036-	\$228.88	\$236.48	\$332.88	\$355.11
	41"(1041mm)	TPAP-3041-	228.88	236.48	332.88	355.11

Feature

- Includes two painted or wood accent plate and attachment hardware.

Specification Tips

- Not for use on 18"(457mm) depth PopUp tables.
- Leg accent plate is located in the top center section of each leg assembly and allows for a user-specified accent color for aesthetic purposes.
- Size must match depth and height of table.

To Order, Specify:

- 1) Product number, including:

① Surface Option:

- P** Paint
- W** Wood

- 2) Paint or wood finish color.

PopUp Table

Vertical Wire Channel – Leg Attached

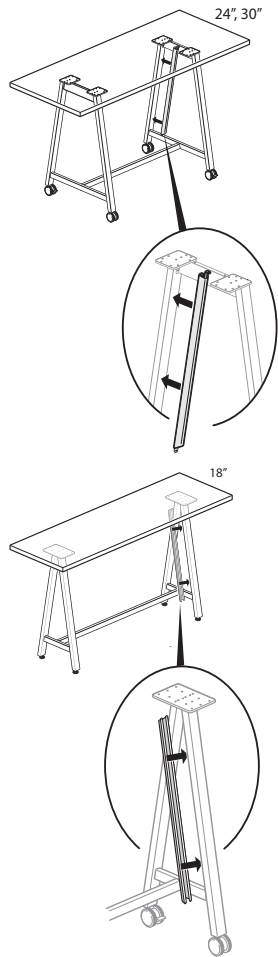

For Use With	Width	Number	Trim A	B
No Accent Plate				
36"H Table	2"(51mm)	TPVW-3602-PN	\$134.16	\$139.99
41"H Table	2"(51mm)	TPVW-4102-PN	149.76	156.64
With Accent Plate				
36"H Table	2"(51mm)	TPVW-3302-PA	\$124.80	\$130.00
41"H Table	2"(51mm)	TPVW-3802-PA	140.40	146.65

Feature

- Includes one painted vertical wire channel and attachment hardware.

Specification Tip

- When specifying a Vertical Wire Channel no Accent Plate or with Accent Plate, order correct model for table height.

To Order, Specify:

- 1) Product number.
- 2) Trim color.

TPVW

PREMISE Tables

This page intentionally blank

PREMISE Tri Tables — Transactional

Symmetric with Glides or Casters

Width	Number ①	Laminate A		Laminate B	
		J	F	J	F
36"(914mm)	NCTY-36-L G	\$1359.07	\$1819.83	\$1448.91	\$1946.53
42"(1067mm)	NCTY-42-L G	1421.77	1888.07	1511.61	2015.21
48"(1219mm)	NCTY-48-L G	1484.47	1956.31	1574.31	2083.89
60"(1524mm)	NCTY-60-L G	1609.87	2092.79	1699.71	2221.25

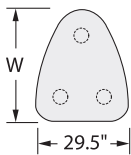
NCTY-LFG
NCTY-LVG

Features

- Includes worksurface, three angled legs with sleeved glides, and mounting hardware.
- Laminate surface with edgeband or knife edge.
- 6"(152mm) adjustment range allows table heights from 26"(660mm) to 32"(813mm).
- Shipped unassembled.

Specification Tips

- Tables are predrilled to accommodate stand alone worktop mounted screens without modesty.
- Does not accept AKP.
- Specify trim color for upper leg sleeves. Lower sleeves are standard in black finish color only.

To Order, Specify:

- 1) Product number, including:

① Edge Option:

- J Edgeband
- F Knife

- 2) Laminate color for surface.
- 3) Edge trim color.
- 4) Leg/upper leg sleeve(s) trim color.

Note: Upcharge (list) for Metallic and accent trim color.
Legs = **\$30.09**.

36"(914mm)	NCTY-36-L M	\$1540.51	\$2001.27	\$1630.35	\$2127.97
42"(1067mm)	NCTY-42-L M	1603.21	2069.51	1693.05	2196.65
48"(1219mm)	NCTY-48-L M	1665.91	2137.75	1755.75	2265.33
60"(1524mm)	NCTY-60-L M	1791.31	2274.23	1881.15	2402.69

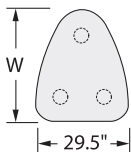
NCTY-LFM
NCTY-LVM

Features

- Includes worksurface, three angled legs, two with locking casters, and mounting hardware.
- Laminate surface with edgeband or knife edge.
- 5"(127mm) adjustment range allows table heights from 27"(686mm) to 32"(813mm) in 1"(25mm) increments.
- Shipped unassembled.

Specification Tips

- Tables are predrilled to accommodate stand alone worktop mounted screens without modesty.
- Does not accept AKP.
- Specify trim color for upper leg sleeves. Lower sleeves and casters are standard in black finish color only.

To Order, Specify:

- 1) Product number, including:

① Edge Option:

- J Edgeband
- F Knife

- 2) Laminate color for surface.
- 3) Edge trim color.
- 4) Leg/upper leg sleeve(s) trim color.

Note: Upcharge (list) for Metallic and accent trim color.
Legs = **\$30.09**.

PREMISE Square/Round

Height	Depth	Diameter	Number		Laminate A		Laminate B		Wood Group A		Wood Group B	
			①	②	J	F	J	F	K	U	K	U
29"(737mm)	24"(610mm)	24"(610mm)	NCS	-2424-	\$ 937.48	\$1142.98	\$ 951.65	\$1157.15	\$1406.22	\$1849.26	\$1528.80	\$1971.84
29"(737mm)	30"(762mm)	30"(762mm)	NCS	-3030-	1057.27	1272.61	1080.17	1295.51	1638.69	2081.73	1802.73	2245.77
29"(737mm)	36"(914mm)	36"(914mm)	NCS	-3636-	1201.44	1426.62	1235.01	1460.19	1915.46	2358.50	2128.84	2571.88

Square — Laminate or Wood Top



NCSL
NCSW

Features

- Includes 1 3/16"(30mm) thick standard top, 2 1/4"(57mm) column base and hardware.
- Laminate top with knife edge or 3mm edgeband edges or wood veneer top with 3mm wood edgeband or knife edge.
- Self-adjusting glides.
- NCRL-3060 clearance from edge of table to center of column is 15"(381mm).
- Column is 2 1/4"(57mm) thick.

Note: Separately specified worksurface reinforcement channels provide additional support for laminate or wood worksurfaces with 54"(1372mm) spans that are heavily loaded and not otherwise supported by mid-span cantilevers, worksurface supports, legs, or under-worksurface storage.

To Order, Specify:

1) Product number, including:

① Surface Option:

- L Laminate
- W Wood

② Edge Option:

Laminate:

- J Edgeband
- F Knife

Wood:

- K Edgeband
- U Knife

- 2) Laminate or Wood finish color.
- 3) Edge trim color (laminate only).
- 4) Trim color for base and column.

Note: Upcharge (list) for Metallic and accent trim colors.
Base and column = \$22.15.

Height	Diameter	Number		Laminate A		Laminate B		Wood Group A		Wood Group B	
		①	②	J	F	J	F	K	U	K	U
29"(737mm)	29 3/4"(756mm)	NCC	-30-	\$1281.83	\$1308.94	\$1369.84	\$1396.95	\$1702.10	\$2444.84	\$1777.25	\$2528.39
	35 3/4"(908mm)	NCC	-36-	1300.32	1330.55	1388.78	1419.01	1739.54	2492.60	1821.30	2584.44
	41 3/4"(1060mm)	NCC	-42-	1316.79	1350.14	1400.79	1434.14	1776.99	2540.37	1847.57	2622.71
	47 3/4"(1213mm)	NCC	-48-	1525.92	1562.39	1632.34	1668.81	2124.03	2897.73	2218.16	3005.30

Round — Laminate or Wood Top



NCCL
NCCW

Features

- Includes 1 3/16"(30mm) thick standard top, 2 1/4"(57mm) column base and hardware.
- Laminate top with knife edge or 3mm edgeband edges or wood veneer top with 3mm wood edgeband or knife edge.
- Self adjusting glides.

To Order, Specify:

1) Product number, including:

① Surface Option:

- L Laminate
- W Wood

② Edge Option:

Laminate:

- J Edgeband
- F Knife

Wood:

- K Edgeband
- U Knife

- 2) Laminate or Wood finish color.
- 3) Edge trim color (laminate only).
- 4) Trim color for base and column.

Note: Upcharge (list) for Metallic and accent trim colors.
Base and column = \$22.15.

PREMISE Oval/Rectangular

Height	Depth	Diameter	Number		Laminate A		Laminate B		Wood Group A		Wood Group B	
			①	②	J	F	J	F	K	U	K	U
29"(737mm)	30"(762mm)	60"(1524mm)	NCLL	-3060-	\$1356.42	\$1921.02	\$1360.32	\$1924.92	\$2337.43	\$3039.79	\$2401.54	\$3156.10
		72"(1829mm)	NCLL	-3072-	1435.80	2001.84	1447.50	2013.54	2539.51	3246.91	2615.50	3382.06
29"(737mm)	36"(914mm)	60"(1524mm)	NCLL	-3660-	1430.76	1996.08	1442.46	2007.78	2514.67	3219.55	2589.22	3349.78
		72"(1829mm)	NCLL	-3672-	1524.00	2090.76	1545.06	2111.82	2747.23	3457.15	2835.46	3608.02

Oval — Laminate or Wood Top

NCLV
NCLW

Features

- Includes 1 3/16"(30mm) thick standard top, 2 1/4"(57mm) column base and hardware.
- Laminate top with knife edge or 3mm edgeband edges or wood veneer top with 3mm wood edgeband or knife edge.
- Self-adjusting glides.
- NCRL-3060 clearance from edge of table to center of column is 15"(381mm).
- Column is 2 1/4"(57mm) thick.

Note: Separately specified worksurface reinforcement channels provide additional support for laminate or wood worksurfaces with 54"(1372mm) spans that are heavily loaded and not otherwise supported by mid-span cantilevers, worksurface supports, legs, or under-worksurface storage.

To Order, Specify:

- Product number, including:

① Surface Option:

- L Laminate
- W Wood

② Edge Option:

Laminate:

- J Edgeband
- F Knife

Wood:

- K Edgeband
- U Knife

- Laminate or Wood finish color.
- Edge trim color (laminate only).
- Trim color for base and column.

Note: Upcharge (list) for Metallic and accent trim colors.
Base and column = \$22.15.

Height	Depth	Width	Number		Laminate A		Laminate B		Wood Group A		Wood Group B	
			①	②	J	F	J	F	K	U	K	U
29"(737mm)	30"(762mm)	54"(1372mm)	NCR	-3054-	\$1371.62	\$1955.97	\$1398.20	\$1982.55	\$2325.38	\$3053.48	\$2386.75	\$3165.25
		60"(1524mm)	NCR	-3060-	1413.02	1997.97	1443.70	2028.65	2430.43	3161.17	2498.01	3282.75
		72"(1829mm)	NCR	-3072-	1495.82	2081.97	1534.70	2120.85	2640.53	3376.55	2720.53	3517.75
29"(737mm)	36"(914mm)	54"(1372mm)	NCR	-3654-	\$1441.82	\$2026.77	\$1475.78	\$2060.73	\$2493.83	\$3224.57	\$2565.13	\$3349.87
		60"(1524mm)	NCR	-3660-	1490.42	2075.97	1529.30	2114.85	2614.73	3348.11	2693.17	3484.15
		72"(1829mm)	NCR	-3672-	1587.62	2174.37	1636.34	2223.09	2856.53	3595.19	2949.25	3752.71

Rectangular — Laminate or Wood Top

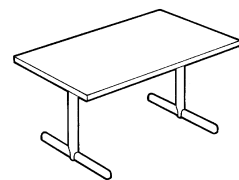
NCRV
NCRW

Features

- Includes 1 3/16"(30mm) thick standard top, 2 1/4"(57mm) column base and hardware.
- Laminate top with knife edge or 3mm edgeband edges or wood veneer top with 3mm wood edgeband or knife edge.
- Self-adjusting glides.
- NCRL-3060 clearance from edge of table to center of column is 15"(381mm).

Note: Separately specified worksurface reinforcement channels provide additional support for laminate or wood worksurfaces with 54"(1372mm) spans that are heavily loaded and not otherwise supported by mid-span cantilevers, worksurface supports, legs, or under-worksurface storage.

To Order, Specify:

- Product number, including:

① Surface Option:

- L Laminate
- W Wood

② Edge Option:

Laminate:

- J Edgeband
- F Knife

Wood:

- K Edgeband
- U Knife

- Laminate or Wood finish color.
- Edge trim color (laminate only).
- Trim color for base and column.

Note: Upcharge (list) for Metallic accent and trim colors.
Base and column = \$22.15.

PREMISE Teardrop

	Height	Depth	Width	Glide/Casters	Number	Laminate A	Laminate B
Teardrop — Laminate Top	29"(737mm)	24"(610mm)	31 1/2"(851mm)	Glides	NCOL-24	\$1398.72	\$1486.74
		30"(762mm)	42"(1067mm)	Glides	NCOL-30	1649.05	1745.07
	29"(737mm)	24"(610mm)	31 1/2"(851mm)	Casters	NCOL-24-C	\$1398.72	\$1486.74
		30"(762mm)	42"(1067mm)	Casters	NCOL-30-C	1649.05	1745.07



NCOL



NCOL-C

Features

- Laminate top with 3mm edgeband.
- Self-adjusting glides or dual-wheel hard casters.
- Straight edges are 24"(610mm) and 30"(762mm) respectively, and are designed to pull up to the end of a 24"(610mm) or 30"(762mm) deep worksurface.

To Order, Specify:

- 1) Product number.
Laminate color for top.
- 2) Edge trim color.
- 3) Trim color for base, column and casters.

Notes: Casters will be charcoal when Metallic trim color is ordered.

Upcharge (list) for Metallic and accent trim colors.

Base and column = **\$22.15**

Reside Tables

This page intentionally blank

Reside Tables — Laminate/Wood

Square

Depth	Width	Number ①②	Laminate A		Laminate B		Wood Group A		Wood Group B	
			J	F	J	F	K	U	K	U
17"(432mm) Height										
36"(914mm)	36"(914mm)	TKRQ-3636-■ ■ SNAG1N	\$567.99	\$ 694.20	\$ 648.76	\$ 774.99	\$ 896.15	\$1103.15	\$ 924.28	\$1137.83
42"(1067mm)	42"(1067mm)	TKRQ-4242-■ ■ SNAG1N	694.20	845.67	812.86	939.07	1088.00	1324.04	1102.32	1398.01
48"(1219mm)	48"(1219mm)	TKRQ-4848-■ ■ SNAG1N	883.53	1072.87	994.60	1183.93	1375.79	1654.72	1441.32	1787.58
29"(737mm) Height										
36"(914mm)	36"(914mm)	TKRQ-3636-■ ■ SNAG4N	\$631.10	\$ 757.31	\$ 711.87	\$ 838.10	\$ 959.26	\$1166.26	\$ 987.39	\$1200.94
42"(1067mm)	42"(1067mm)	TKRQ-4242-■ ■ SNAG4N	757.31	908.78	875.97	1002.18	1151.11	1387.15	1165.43	1461.12
48"(1219mm)	48"(1219mm)	TKRQ-4848-■ ■ SNAG4N	946.64	1135.98	1057.71	1247.04	1438.90	1717.83	1504.43	1850.69

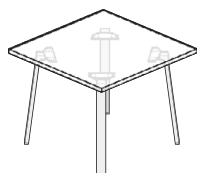

TKRQ

Features

- Includes top, support bracket and four angled legs with attachment hardware.
- Available in:
 - Laminate with 3mm edgeband (J) or knife (F) edge.
 - Wood with 3mm edgeband (K) or knife (U) edge.
- Fixed table height options are 17" and 29".
- Glides provide 1 1/2"(38mm) leveling adjustment.
- Angled legs standard with graphite foot and glide.
- Field assembled.

To Order, Specify:

- 1) Product number, including:

① Top Option:

- L Laminate
- W Wood

② Edge Option:

Laminate:

- J Edgeband
- F Knife

Wood:

- K Edgeband
- U Knife

- 2) Laminate or Wood finish color.
- 3) Edge trim color (laminated only).
- 4) Leg trim color.

Note: \$15.14 upcharge list for Metallic and accent trim colors.

Reside Tables — Laminate/Wood

Round and Pebble

Depth	Width	Number ①②	Laminate A		Laminate B		Wood Group B			
			J	F	J	F	K	U	K	U
Round — 17”(432mm) Height										
36”(914mm)	36”(914mm)	TKRN-3636-■ ■ SNAG1N	\$ 689.49	\$1061.99	\$ 694.58	\$1096.88	\$ 934.48	\$1117.51	\$ 951.94	\$1158.99
42”(1067mm)	42”(1067mm)	TKRN-4242-■ ■ SNAG1N	811.45	1183.95	826.29	1228.60	1114.43	1324.95	1163.90	1403.35
48”(1219mm)	48”(1219mm)	TKRN-4848-■ ■ SNAG1N	1046.86	1419.35	1080.53	1482.83	1386.85	1638.63	1497.33	1772.86
Round — 29”(737mm) Height										
36”(914mm)	36”(914mm)	TKRN-3636-■ ■ SNAG4N	\$ 751.97	\$1124.47	\$ 757.06	\$1159.36	\$ 996.96	\$1179.99	\$1014.42	\$1221.47
42”(1067mm)	42”(1067mm)	TKRN-4242-■ ■ SNAG4N	873.93	1246.43	888.77	1291.08	1176.91	1387.43	1226.38	1465.83
48”(1219mm)	48”(1219mm)	TKRN-4848-■ ■ SNAG4N	1109.34	1481.83	1143.01	1545.31	1449.33	1701.11	1559.81	1835.34
Pebble — 17”(432mm) Height										
36”(914mm)	36”(914mm)	TKRP-3636-■ ■ SNAG1N	\$ 720.73	\$1093.22	\$ 728.31	\$1130.62	\$ 981.97	\$1172.49	\$1007.87	\$1223.75
42”(1067mm)	42”(1067mm)	TKRP-4242-■ ■ SNAG1N	975.47	1347.97	1003.44	1405.74	1171.91	1391.19	1231.63	1481.37
48”(1219mm)	48”(1219mm)	TKRP-4848-■ ■ SNAG1N	1362.39	1734.90	1421.31	1823.61	1456.84	1718.60	1567.27	1867.07
Pebble — 29”(737mm) Height										
36”(914mm)	36”(914mm)	TKRP-3636-■ ■ SNAG4N	\$ 783.21	\$1155.70	\$ 790.79	\$1193.10	\$1044.45	\$1234.97	\$1070.35	\$1286.23
42”(1067mm)	42”(1067mm)	TKRP-4242-■ ■ SNAG4N	1037.95	1410.45	1065.92	1468.22	1234.39	1453.67	1294.11	1543.85
48”(1219mm)	48”(1219mm)	TKRP-4848-■ ■ SNAG4N	1424.87	1797.38	1483.79	1886.09	1519.32	1781.08	1629.75	1929.55



TKRN

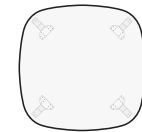

TKRP

Features

- Includes top, support bracket and four angled legs with attachment hardware.
- Available in:
 - Laminate with 3mm edgeband (J) or knife (F) edge.
 - Wood with 3mm edgeband (K) or knife (U) edge.
- Fixed table height options are 17” and 29”.
- Glides provide 1 1/2”(38mm) leveling adjustment.
- Angled legs standard with graphite foot and glide.
- 36” Round and Pebble tables do not meet knee space clearance requirements.
- Field assembled.

To Order, Specify:

1) Product number, including:

① Top Option:

- L Laminate
- W Wood

② Edge Option:

Laminate:

- J Edgeband
- F Knife

Wood:

- K Edgeband
- U Knife

- 2) Laminate or Wood finish color.
- 3) Edge trim color (laminated only).
- 4) Leg trim color.

Note: \$15.14 upcharge list for Metallic and accent trim colors.

Reside Tables — Laminate/Wood

Hex

Depth	Width	Number ① ② ③	Laminate A		Laminate B		Wood Group B		K	U
			J	F	J	F	K	U		
36"(914mm)	60"(1524mm)	TKRX-3660-■ ■ S ■ AG4N	\$ 940.64	\$1408.84	\$1022.17	\$1546.64	\$1433.35	\$1649.16	\$1520.47	\$1786.96
42"(1067mm)	60"(1524mm)	TKRX-4260-■ ■ S ■ AG4N	1102.25	1661.06	1196.90	1843.04	1653.05	1901.38	1779.17	2083.36
48"(1219mm)	60"(1524mm)	TKRX-4860-■ ■ S ■ AG4N	1263.86	1913.28	1371.63	2139.44	1872.75	2153.60	2037.87	2379.76
36"(914mm)	72"(1829mm)	TKRX-3672-■ ■ S ■ AG4N	\$1046.94	\$1575.24	\$1136.97	\$1742.67	\$1577.64	\$1815.56	\$1690.47	\$1982.99
42"(1067mm)	72"(1829mm)	TKRX-4272-■ ■ S ■ AG4N	1224.56	1852.16	1329.00	2068.17	1819.45	2092.48	1975.20	2308.49
48"(1219mm)	72"(1829mm)	TKRX-4872-■ ■ S ■ AG4N	1402.17	2127.79	1521.03	2392.12	2059.95	2368.11	2258.40	2632.44
36"(914mm)	96"(2438mm)	TKRX-3696-■ ■ S ■ AG4N	\$1392.03	\$2113.45	\$1499.06	\$2340.14	\$2045.63	\$2353.77	\$2209.88	\$2580.46
42"(1067mm)	96"(2438mm)	TKRX-4296-■ ■ S ■ AG4N	1623.53	2473.56	1747.55	2757.63	2358.95	2713.88	2573.96	2997.95
48"(1219mm)	96"(2438mm)	TKRX-4896-■ ■ S ■ AG4N	1853.52	2833.72	1994.56	3174.39	2672.25	3074.04	2937.36	3414.71

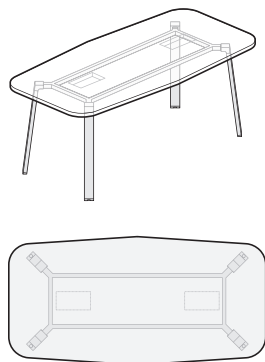

TKRX

Features

- Includes top, support beams and four angled legs with attachment hardware.
- Available in:
 - Laminate with 3mm edgeband (J) or knife (F) edge.
 - Wood with 3mm edgeband (K) or knife (U) edge.
- Fixed table height is 29"(737mm).
- Glides provide 1 1/2"(38mm) leveling adjustment.
- Angled legs standard with graphite foot and glide.
- Legs and support beam trim colors match.
- Hatch Cutout Option includes:
 - No cutout (N)
 - One cutout; right (R) or left (L)
 - Two cutouts (E); right and left
- Field assembled.

Specification Tip

- Hatch wire tray and power and communication cabling are separately specified.

To Order, Specify:

- 1) Product number, including:

① Top Option:

- L Laminate
- W Wood

② Edge Option:

Laminate:

- J Edgeband
- F Knife

Wood:

- K Edgeband
- U Knife

③ Hatch Cutout Option:

- N No Cutout
- L Cutout – Left, add \$45.43 list
- R Cutout – Right, add \$45.43 list
- E Two Cutouts, add \$90.86 list
One left/one right

- 2) Laminate or Wood finish color.
- 3) Edge trim color (laminated only).
- 4) Base trim color.

Note: \$15.14 upcharge list for Metallic and accent trim colors.

Reside Tables — Laminate/Wood

Rectangular

Depth	Width	Number ① ② ③	Laminate A		Laminate B		Wood Group A		Wood Group B	
			J	F	J	F	K	U	K	U
36"(914mm)	60"(1524mm)	TKRA-3660-■ ■ S ■ AG4N	\$1324.21	\$1556.60	\$1382.02	\$1614.41	\$1810.07	\$2048.13	\$1994.75	\$2232.81
42"(1067mm)	60"(1524mm)	TKRA-4260-■ ■ S ■ AG4N	1390.21	1622.60	1455.22	1687.61	1915.67	2153.73	2118.35	2356.41
48"(1219mm)	60"(1524mm)	TKRA-4860-■ ■ S ■ AG4N	1456.21	1688.60	1528.42	1760.81	2021.27	2259.33	2241.95	2480.01
36"(914mm)	72"(1829mm)	TKRA-3672-■ ■ S ■ AG4N	\$1405.09	\$1637.48	\$1471.54	\$1703.93	\$1938.47	\$2176.53	\$2144.75	\$2382.81
42"(1067mm)	72"(1829mm)	TKRA-4272-■ ■ S ■ AG4N	1483.33	1715.72	1558.42	1790.81	2064.23	2302.29	2292.11	2530.17
48"(1219mm)	72"(1829mm)	TKRA-4872-■ ■ S ■ AG4N	1561.57	1793.96	1645.30	1877.69	2189.99	2428.05	2439.47	2677.53
36"(914mm)	96"(2438mm)	TKRA-3696-■ ■ S ■ AG4N	\$1566.85	\$1799.24	\$1650.58	\$1882.97	\$2195.27	\$2433.33	\$2444.75	\$2682.81
42"(1067mm)	96"(2438mm)	TKRA-4296-■ ■ S ■ AG4N	1669.57	1901.96	1764.82	1997.21	2361.35	2599.41	2639.63	2877.69
48"(1219mm)	96"(2438mm)	TKRA-4896-■ ■ S ■ AG4N	1772.29	2004.68	1879.06	2111.45	2527.43	2765.49	2834.51	3072.57

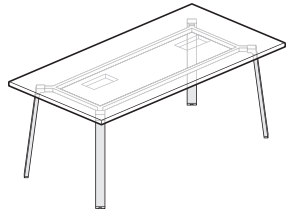

TKRA

Features

- Includes top, beams and four angled legs with attachment hardware.
- Available in:
 - Laminate with 3mm edgeband (J) or knife (F) edge.
 - Wood with 3mm edgeband (K) or knife (U) edge.
- Fixed table height is 29"(737mm).
- Glides provide 1 1/2"(38mm) leveling adjustment.
- Angled legs standard with graphite foot and glide.
- Legs and support beam trim colors match.
- Hatch Cutout Option includes:
 - No cutout (N)
 - One cutout; right (R) or left (L)
 - Two cutouts (E); right and left
- Field assembled.

Specification Tip

- Hatch wire tray and power and communication cabling are separately specified.

To Order, Specify:

- 1) Product number, including:

① Top Option:

- L Laminate
- W Wood

② Edge Option:

Laminate:

- J Edgeband
- F Knife

Wood:

- K Edgeband
- U Knife

③ Hatch Cutout Option:

- N No Cutout
- L Cutout – Left, add \$45.43 list
- R Cutout – Right, add \$45.43 list
- E Two Cutouts, add \$90.86 list
One left/one right

- 2) Laminate or Wood finish color.
- 3) Edge trim color (laminated only).
- 4) Base trim color.

Note: \$15.14 upcharge list for Metallic and accent trim colors.

Fixed Height Tables Specification Guide

Table of Contents – Fixed Height Tables Specification Guide

Cultivate Tables Specification Guide

Product Details – Cultivate Tables

Cultivate Tops

Overview	412
Seating Capacity	413
No Storage – Flush To Frame	414
No Storage – Overhanging Frame	415
Storage on One Side	416
Storage on Two Sides (One-Piece Top)	417
Storage on Two Sides (Two-Piece Top)	418

Cultivate Frames

Seated Height	419
Standing Height	420

Cultivate Accessories

Bag Hook	421
----------	-----

Cultivate Electrical Components

Seamless Enhanced Power Module	422
Wireless Charging Module	423
Flush Mount Power Module	424
Flip Top Unit – Double Sided	425

Cultivate Wire Management

Vertical Wire Channel	426
Wire Management Basket	427

Product Applications – Cultivate Tables

Overview	430
Specifying Cultivate Tables In Five Easy Steps	431
Standard Cultivate Table Applications	434
Power/Data and Wire Management Applications	438
Monitor Mounting and Information Display Applications	441

Technical Specifications – Cultivate Tables

Technical Specifications	446
--------------------------	-----

Immerse Tables Specification Guide

Product Details – Immerse Tables

Product Introduction	448
Product Introduction – The Immerse Family of Tables	449
Top Construction and Edge Details	450
Table Heights	451

Single Tables

Round	452
Square	453
Rectangle (One-Piece Top)	454
Rectangle (Two-Piece Top)	455
Racetrack	456

Stack Tables

Rectangle (One-Piece Top)	457
Rectangle (Two-Piece Top)	458

Table of Contents – Specification Guides – Fixed Height Tables

Immerse Tables Specification Guide (Continued)

Shift Tables

Rectangle / Rectangle	459
Rectangle / Round	460
Racetrack / Round	461

Overlap Table

Rectangle / Rectangle	462
Rectangle / Round	463
Racetrack / Round	464
Rectangle / Ledge	465

Ledge Table	466
-------------------	-----

Planter Oblong	467
----------------------	-----

Planter Round	468
---------------------	-----

Technical Specifications – Immerse Tables

Technical Specifications	470
--------------------------------	-----

Jive Tables Specification Guide

Product Details – Jive Tables

Jive Tables – Overview

Jive Base Options and Top Shapes	474
Jive Top Options	477
Jive Electrical Components, Wire Management, Screens and Modesty Panels	478

Jive Tables – Post Extruded Base

Round	479
Square	480
Pebble Symmetrical	481
Pebble Asymmetrical	482
Rectangle	483
Racetrack	484
Trapezoid	485
Crescent	486
Half Racetrack	487
Half Pebble	488

Jive Tables – Post Round Base

Round	489
Square	490
Pebble Symmetrical	491
Pebble Asymmetrical	492
Rectangle	493
Racetrack	494
Trapezoid	495
Crescent	496
Half Racetrack	497
Half Pebble	498

Jive Tables – X Base

Round	499
Square	500
Pebble	501
Rectangle	502

Table of Contents – Specification Guides – Fixed Height Tables

Jive Tables Specification Guide (Continued)

Jive Tables – Bridge Base

Round	503
Square	504
Pebble Symmetrical.....	505
Pebble Asymmetrical	506-511
Rectangle	512-517
Racetrack	518-523
Half Racetrack	524-525
Half Pebble.....	526-527
Half Hexagon.....	528

Jive Tables – C-Leg Tables

Rectangle – Extruded Column	529
Rectangle – Round Column.....	530
Rectangle – Extruded Column – Flip Base	531
Rectangle – Round Column - Flip Base	532

Jive Tables – Disc Base

Round	533
Square	534
Pebble	535
Rectangle	536

Jive Tables – Dual Disc Base

Pebble Asymmetrical	537
Rectangle	538
Racetrack	539

Jive Tables – T-Leg

Extruded Column

Rectangle	540
Pebble.....	542
Racetrack.....	543
Trapezoid.....	544

Round Column

Rectangle.....	546
Pebble.....	548
Racetrack.....	549
Trapezoid.....	550

Flip Base – Extruded Column

Rectangle.....	551
----------------	-----

Flip Base – Round Column

Rectangle.....	552
----------------	-----

Swivel Base

Square	553
Rectangle	554
Trapezoid	555
Crescent.....	556
Corner, Transitional Extended	557
Corner, Extended	558

Table of Contents – Specification Guides – Fixed Height Tables

Planes Tables Specification Guide

Product Details – Planes Tables

Planes Tables Introduction	560
Planes Tables – Collaborative Y-Leg Tables	
Overview	561
Rectangular Flip Top or Non-Flip Top	562
Pebble Flip Top or Non-Flip Top	563
Hexagon Flip Top or Non-Flip Top	564
Half Round Flip Top or Non-Flip Top	565
Polygon Flip Top or Non-Flip Top	566
Sizes and Dimensions For Nested Tables in Flipped Position	567
Planes Tables – X Base	
Overview	568
Single Base	569
Dual Base	570
Planes Tables – Disc Base	
Overview	571
Single Base	572
Dual Base	573
Options and Features – Edge Options for Laminate and Wood Table Tops	574
Planes Tables – Power Components	
Flip Top Units	575
Flip Top Units	576
Flush Mount Power Module	577
Bezel Utility Module	578
Power Tap – Corded	579
workware Interface Module – Non-Switching	580
Planes Tables – C-Leg Training Table	
Overview	581
Rectangular – Flip Top or Non-Flip Top Training Table	583
Crescent – Flip Top or Non-Flip Top Training Table	584
Trapezoid – Flip Top or Non-Flip Top Training Table	585
Polygon – Flip Top or Non-Flip Top Training Table	586
Pie Connector	587
Modesty Panels	588
Flip Top Table Heights and Nesting	589
3mm Edgeband	590
Knife Edge	591
Flip Top Unit Centered Back Cutout Locations	592
Flip Top Unit Left and Right Back Cutout Locations	593
Electrical Components – Flip Top Units	594
Electrical Components – Quick Connect Power Flip Top Unit	596
Training Tables Electrical – 2-Circuit Power Distribution System	597
Wire Management Through the Stretcher	598
Training Tables Electrical – Power Distribution System Planning	599
Electrical Components– 2-Circuit Power Applications	600
Electrical Components – 2-Circuit Power Applications	601
Planes Training Table Applications	603

Table of Contents – Specification Guides – Fixed Height Tables

Planes Tables Specification Guide (Contintued)

Planes Carts

Overview.....	605
Cart – Small Media.....	606
Cart – Medium Media.....	607
Cart – Catering.....	608
Cart – Podium.....	609

Planes Credenza

Overview.....	610
Credenza Top.....	611
Credenza Base – 19” High.....	612
Credenza Base with Slider– 29” High.....	614
Credenza Base with Slider – 35” High.....	616
Credenza Base – 29” High.....	618
Credenza Base with Slider – 39” High.....	620
Credenza Base with Slider – 45” High.....	622

Planes – Interior Leg Conference Tables

Overview.....	624
Round (One-Piece Top).....	627
Round (Two-Piece Top).....	628
Square (One-Piece Top).....	629
Square (Two-Piece Top).....	630
Rectangular – 48”-66” wide (One-Piece).....	631
Half Round.....	634
Polygon.....	635
Rectangular– 72”-120” wide (One-Piece Top).....	636
Pebble (One-Piece Top).....	639
Hexagon (One-Piece Top).....	642
Rectangular (Two-Piece Top).....	645
Pebble (Two-Piece Top).....	649
Hexagon (Two-Piece Top).....	653
Rectangular (Three-Piece Top).....	657
Pebble (Three-Piece Top).....	662
Hexagon (Three-Piece Top).....	667

Planes – Perimeter Leg Conference Tables

Overview.....	672
Square (One-Piece Top).....	674
Square (Two-Piece Top).....	675
Rectangular 60”-78” wide (One-Piece).....	673
Rectangular 72”-120” wide (One-Piece).....	679
Rectangular (Two-Piece Top).....	682
Rectangular (Three-Piece Top).....	686
Power Components – Flip Top Units.....	691
Cable Management	
Cable Base.....	692
Cable Column.....	693
Horizontal Wire Manager.....	694
Planning Guidelines for the Horizontal Wire Manager.....	695

Table of Contents – Specification Guides – Fixed Height Tables

Planes Tables Specification Guide (Contintued)

Planes – Conference Table Top (for use with Column Base)

Overview	696
Round / Square / Pebble Top	698
Rectangle / Pebble / Hexagon (One-Piece Top)	701
Rectangle / Pebble / Hexagon tops (Two-Piece Top)	705
Rectangle / Pebble / Hexagon tops (Three-Piece Top)	711

Planes – End Supported Top (for use with Column Base)

Overview	718
D-Shape / Rectangle / Key Conference Top	719

Planes Column Base

Frame	727
Cladding	728
Plate	729
J-Channels	730

Technical Specifications – Planes Tables

Technical Specifications	732
--------------------------------	-----

Product Details – PopUp Tables

PopUp Tables

Rectangle	736
Oval (Rectangle Radius Corner)	738
Racetrack	740
Accent Plates	742
Vertical Wire Channel	743
Electrical Components	744
Bag Hook	747

Technical Specifications – PopUp Tables

Technical Specifications	750
--------------------------------	-----

This page intentionally left blank.

Cultivate Tables Specification Guide

Product Details Section

Product Details – Cultivate Tables

Tops – Overview

Top – No Storage Flush To Frame

TYRA

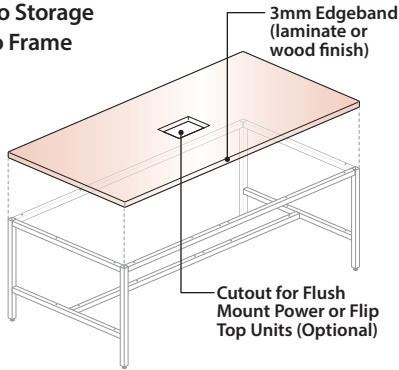

Top – No Storage Overhanging Frame

TYRA

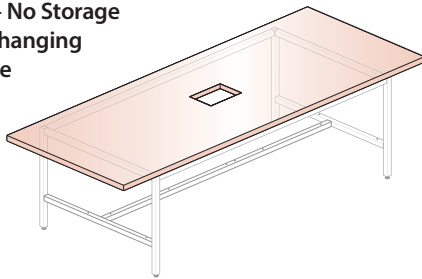

Top for use with Storage – Storage on One Side

TYRA

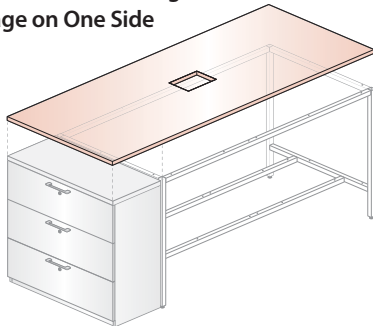

Top for use with Storage – Storage on Two Sides (One-Piece Top)

TYRA

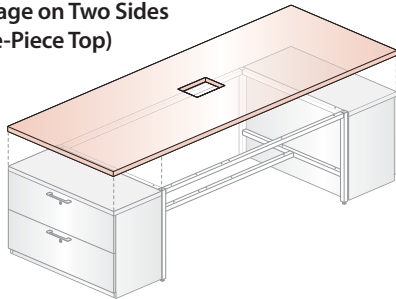

Top for use with Storage – Storage on Two Sides (Two-Piece Top)

TYRA

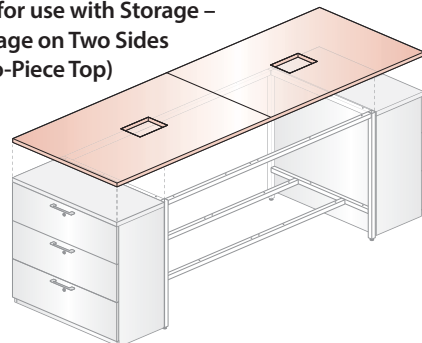

Component Materials/Finishes

COMPONENT NAME	MATERIALS/ FINISHES	
Cultivate Top • 1 3/16" Thick or 2" Thick	(L) Laminate Surface / (J) Laminate Edgeband	Specify laminate surface color and separate specification for the edge trim color.
	(W) Wood Surface/ (K) Wood Edgeband	Specify a single wood finish/color for the surface and the edge.

Edge Details

1 3/16" Thick Top – Edge Profile
Solid core construction with 3mm Edgeband.

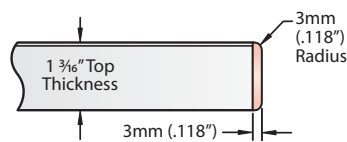

2" Thick Top – Edge Profile
Hollow core construction with 6" built up perimeter and 3mm Edgeband.

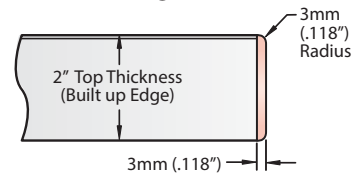

Cutout Options

(X) Center Cutout – Flush Mount Power Module – 4 Port
• Includes a 2" W x 6 3/4" D factory cutout, centered in the middle of the top.

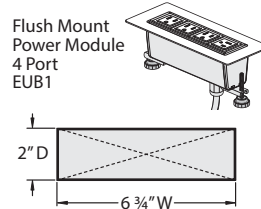

(Z) Center Cutout – Flush Mount Power Module – 6 Port
• Includes a 2" W x 9 3/4" D factory cutout, centered in the middle of the top.

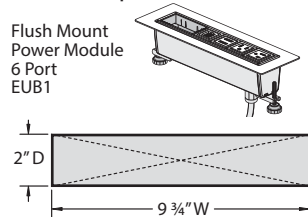

(M) Center Cutout – Flip Top Unit – Double Sided – 8 Port
• Includes a 8" W x 7 1/16" D factory cutout, centered in the middle of the top.

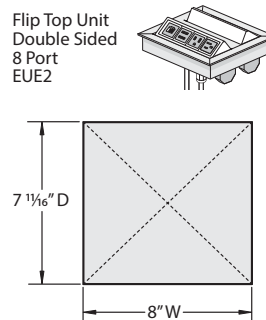

(Q) Center Cutout – Flip Top Unit – Double Sided – 12 Port
• Includes a 2" W x 9 3/4" D factory cutout, centered in the middle of the top.

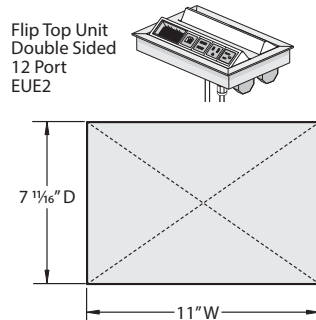

Note

- All Electrical Components must be separately specified.
- Cutouts for other types of Electrical Components must be field cut or ordered through Tailored Solutions.

Product Details – Cultivate Tables

Cultivate Tops – Seating Capacity

Top – No Storage – Flush To Frame

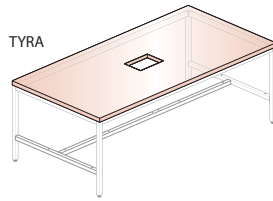

		WIDTHS			
		60" Wide	72" Wide	84" Wide	96" Wide
DEPTHS	36" Deep	4 Chairs Maximum	4 Chairs Maximum	6 Chairs Maximum	6 Chairs Maximum
	42" Deep	4 Chairs Maximum	4 Chairs Maximum	6 Chairs Maximum	6 Chairs Maximum

Top – No Storage – Overhanging Frame

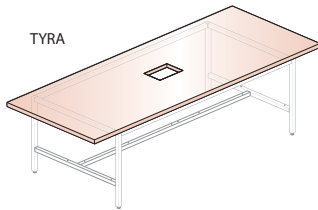

		WIDTHS	
		108" Wide	120" Wide
DEPTHS	36" Deep	8 Chairs Maximum	8 Chairs Maximum
	42" Deep	8 Chairs Maximum	8 Chairs Maximum

Top for use with Storage – Storage on One Side

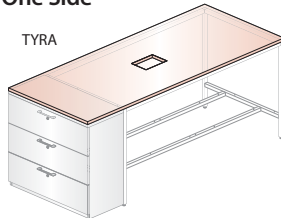

		WIDTHS			
		79" Wide	91" Wide	103" Wide	115" Wide
DEPTHS	36" Deep	4 Chairs Maximum	4 Chairs Maximum	6 Chairs Maximum	6 Chairs Maximum
	42" Deep	4 Chairs Maximum	4 Chairs Maximum	6 Chairs Maximum	6 Chairs Maximum

Top for use with Storage – Storage on Two Sides (One-Piece Top)

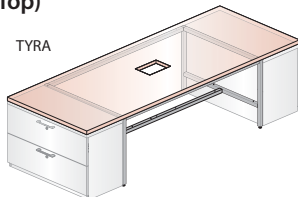

		WIDTHS	
		98" Wide	110" Wide
DEPTHS	36" Deep	4 Chairs Maximum	4 Chairs Maximum
	42" Deep	4 Chairs Maximum	4 Chairs Maximum

Top for use with Storage – Storage on Two Sides (Two-Piece Top)

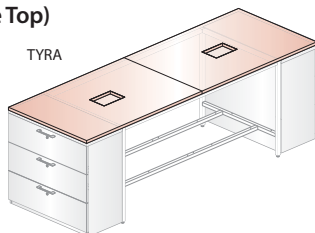

		WIDTHS	
		122" Wide	134" Wide
DEPTHS	36" Deep	6 Chairs Maximum	6 Chairs Maximum
	42" Deep	6 Chairs Maximum	6 Chairs Maximum

Note • Recommended seating capacity based upon a width of 27" per chair.

Product Details – Cultivate Tables

Cultivate Tops – No Storage – Flush To Frame

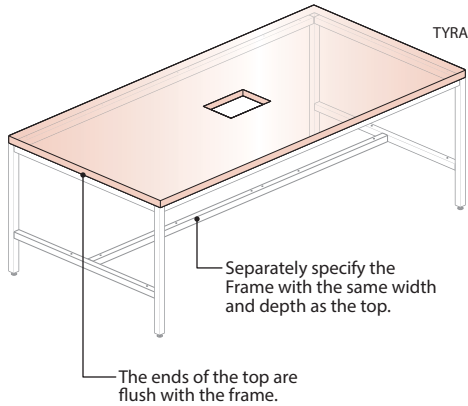

Wood Grain Direction



Wood Veneers

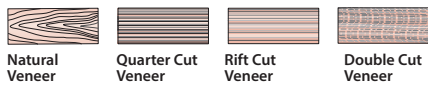

Wood Grain Laminate



Top View

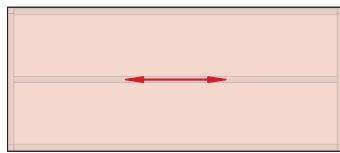

Flush to Frame Application

- Flush To Frame Tops are pre-drilled to attach flush to frames.
- The Separately specified Frame must be the same width and depth as the top.
- Cutout options provide a single cutout for use with a separately specified power module.

Dimensions

Top View

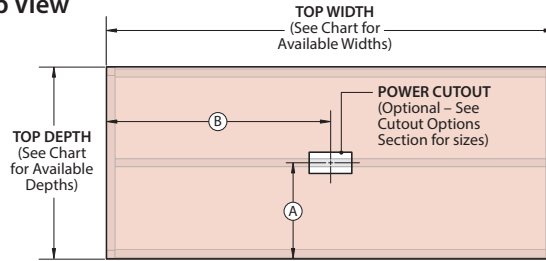

Front View – with Seated Height Frame

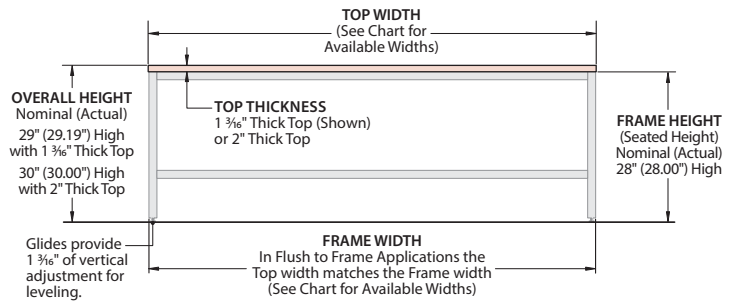

Front View – with Standing Height Frame

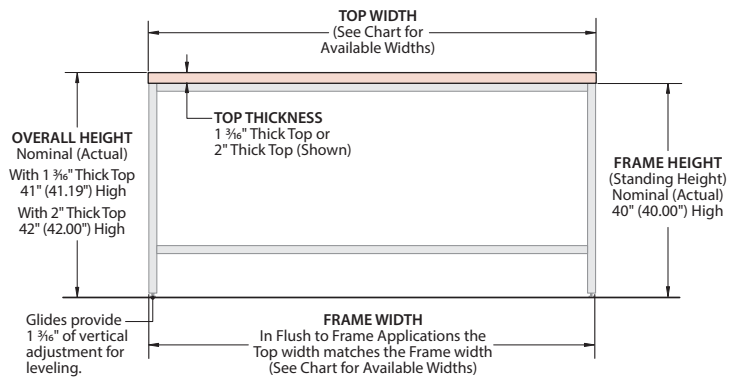

TOP			CUTOUT LOCATION		FRAME
DEPTH Nominal (Actual)	WIDTH Nominal (Actual)	Number of Top Pieces	(A)	(B)	Tops are Pre-Drilled to fit the corresponding Frame Sizes
36" (35.97")	60" (59.68")	1	18"	29 7/8"	60" Wide x 36" Deep
	72" (71.68")	1	18"	35 7/8"	72" Wide x 36" Deep
	84" (83.68")	1	18"	41 7/8"	84" Wide x 36" Deep
	96" (95.68")	1	18"	47 7/8"	96" Wide x 36" Deep
42" (41.97")	60" (59.68")	1	21"	29 7/8"	60" Wide x 42" Deep
	72" (71.68")	1	21"	35 7/8"	72" Wide x 42" Deep
	84" (83.68")	1	21"	41 7/8"	84" Wide x 42" Deep
	96" (95.68")	1	21"	47 7/8"	96" Wide x 42" Deep

Product Details – Cultivate Tables

Cultivate Tops – No Storage – Overhanging Frame

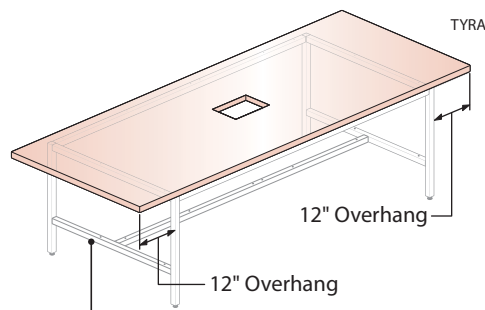

Separately specify the width of the frame to be 24" less than the width of the top. Depths should match

Wood Grain Direction



Arrow indicates Wood Grain Direction

Wood Veneers

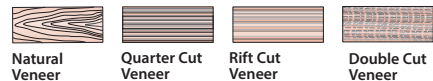

Wood Grain Laminate



Wood Grain Laminate

Top View



Top Overhanging Frame Application

- Consists of the following separately specified components:
 - Cultivate Top (No Storage) – Flush To Frame
 - Cultivate Frame
- Overhang Tops are pre-drilled to attach to a frame with a 12" overhang on both ends.
- The Frame should be specified 24" less than the width of the Top and with the same depth as the top.

Dimensions Top View

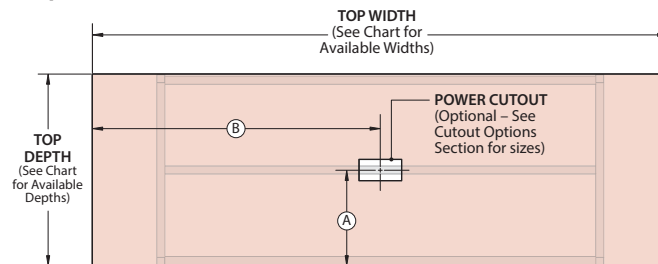

Front View – with Seated Height Frame

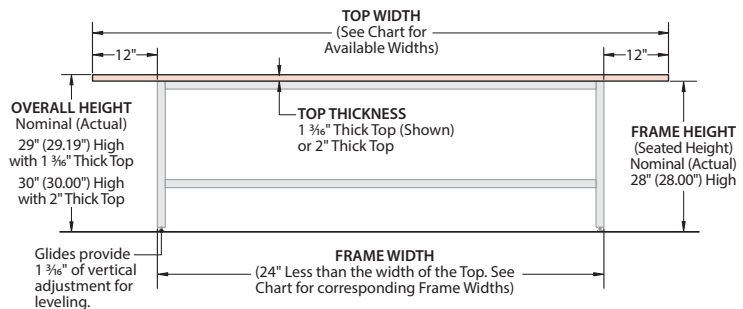

Front View – with Standing Height Frame

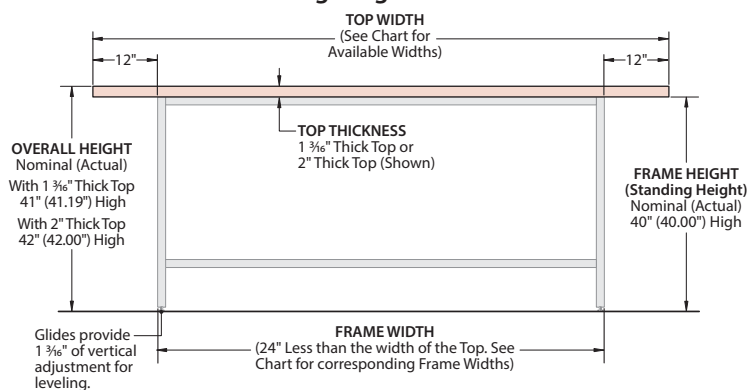

TOP		CUTOUT LOCATION		FRAME	
DEPTH Nominal (Actual)	WIDTH Nominal (Actual)	Number of Top Pieces	(A)	(B)	Tops are Pre-Drilled to fit the corresponding Frame Sizes
36" (35.97")	108" (107.68")	1	18"	53 7/8"	84" Wide x 36" Deep
	120" (119.68")	1	18"	59 7/8"	96" Wide x 36" Deep
42" (41.97")	108" (107.68")	1	21"	53 7/8"	84" Wide x 42" Deep
	120" (119.68")	1	21"	59 7/8"	96" Wide x 42" Deep

Product Details – Cultivate Tables

Top for use with Storage – Storage on One Side

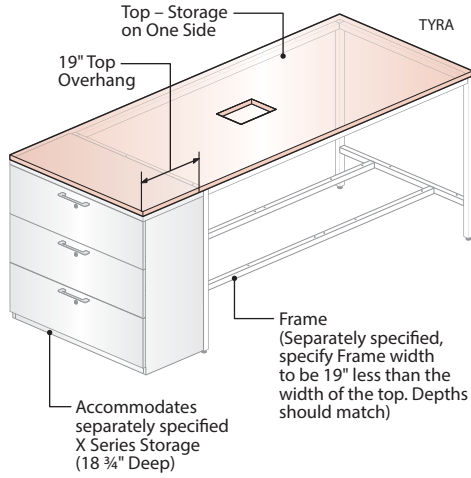

Wood Grain Direction



Arrow indicates Wood Grain Direction

Wood Veneers

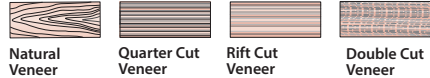

Wood Grain Laminate



Top View

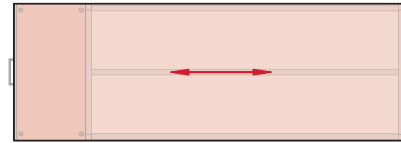

Storage on One Side Application

- Consists of the following separately specified components:
 - Cultivate Top - Storage on 1 Side
 - Cultivate Frame
 - (1) X Series Storage Unit
- Tops – Storage on One Side are pre-drilled to attach to a frame that is 19" less than the width of the top. The top will overhang the frame 19" on one side and be flush to the frame on the other side.
- The 19" overhang must be supported by a separately specified X Series Storage Unit (the 19" overhang cannot be unsupported).
- Seated Height Frames are for use with 2 High X Series Storage.
- Standing Height Frames are for use with 3 High X Series Storage.

Dimensions

Top View

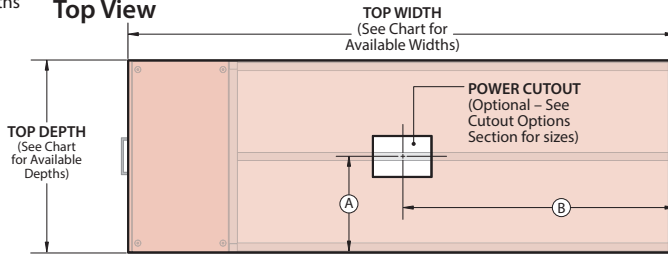

Front View – with Seated Height Frame

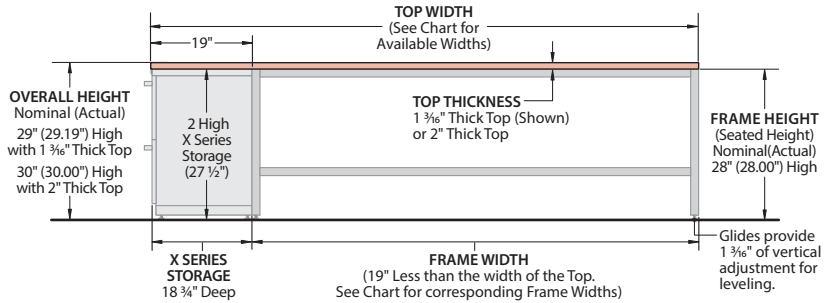

Front View – with Standing Height Frame

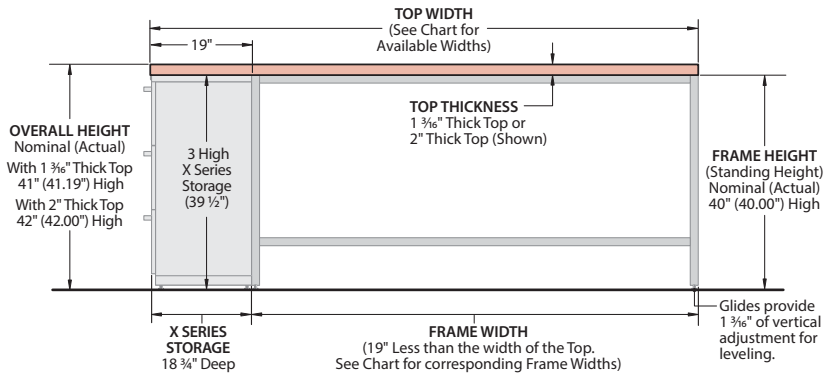

TOP			CUTOUT LOCATION		FRAME
DEPTH Nominal (Actual)	WIDTH Nominal (Actual)	Number of Top Pieces	(A)	(B)	Tops are Pre-Drilled to fit the corresponding Frame Sizes
36" (35.97")	79" (78.43")	1	18"	39 1/8"	60" Wide x 36" Deep
	91" (90.43")	1	18"	45 1/8"	72" Wide x 36" Deep
	103" (102.43")	1	18"	51 1/8"	84" Wide x 36" Deep
	115" (114.43")	1	18"	57 1/8"	96" Wide x 36" Deep
42" (41.97")	79" (78.43")	1	21"	39 1/8"	60" Wide x 42" Deep
	91" (90.43")	1	21"	45 1/8"	72" Wide x 42" Deep
	103" (102.43")	1	21"	51 1/8"	84" Wide x 42" Deep
	115" (114.43")	1	21"	57 1/8"	96" Wide x 42" Deep

Product Details – Cultivate Tables

Cultivate Top for use with Storage – Storage on Two Sides (One-Piece Top)

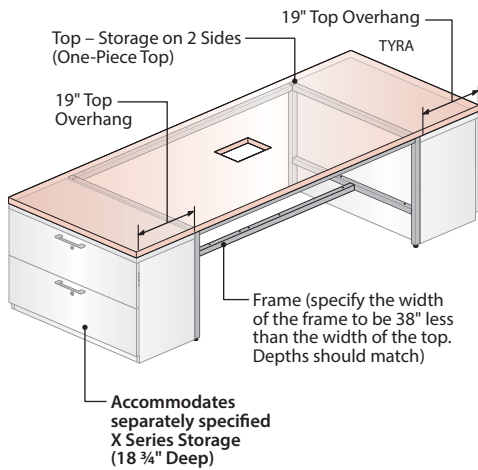

Wood Grain Direction



Arrow indicates Wood Grain Direction

Wood Veneers

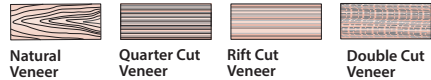

Wood Grain Laminate



Wood Grain Laminate

Top View



Storage on One Side Application

- Consists of the following separately specified components:
 - Cultivate Top - Storage on Two Sides (One-Piece Top)
 - Cultivate Frame
 - (2) X Series Storage Unit
- Top – Storage on Two Sides (One-Piece Top) is pre-drilled to attach to a frame that is 38" less than the width of the top. The top will overhang the frame 19" on both sides.
- Each 19" overhang must be supported by a separately specified X Series Storage Unit (the 19" overhang cannot be unsupported).
- Seated Height Frames are for use with 2 High X Series Storage.
- Standing Height Frames are for use with 3 High X Series Storage.

Dimensions

Top View

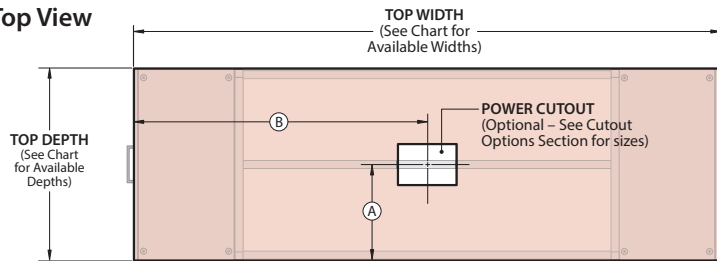

Front View – with Seated Height Frame

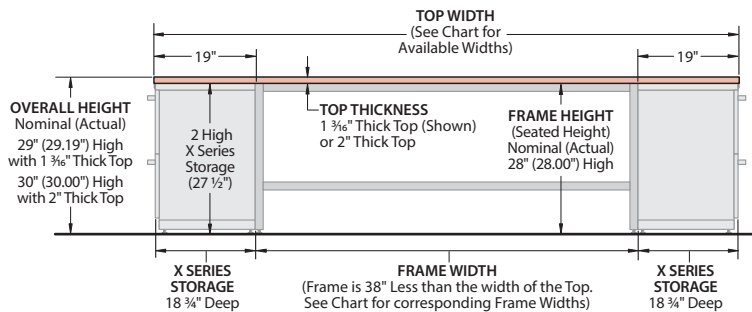

Front View – with Standing Height Frame

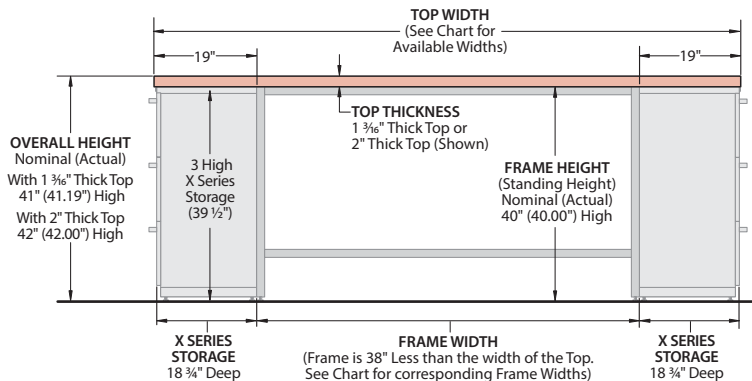

Note • Frame glides provide 1 3/16" of vertical adjustment for leveling.

TOP			CUTOUT LOCATION		FRAME
DEPTH Nominal (Actual)	WIDTH Nominal (Actual)	Number of Top Pieces	Ⓐ	Ⓑ	Tops are Pre-Drilled to fit the corresponding Frame Widths
36" (35.97")	98" (97.18")	1	18"	48 3/4"	60" Wide x 36" Deep
	110" (109.18")	1	18"	54 3/4"	72" Wide x 36" Deep
42" (41.97")	98" (97.18")	1	21"	48 3/4"	60" Wide x 42" Deep
	110" (109.18")	1	21"	54 3/4"	72" Wide x 42" Deep

Product Details – Cultivate Tables

Top for use with Storage – Storage on Two Sides (Two-Piece Top)

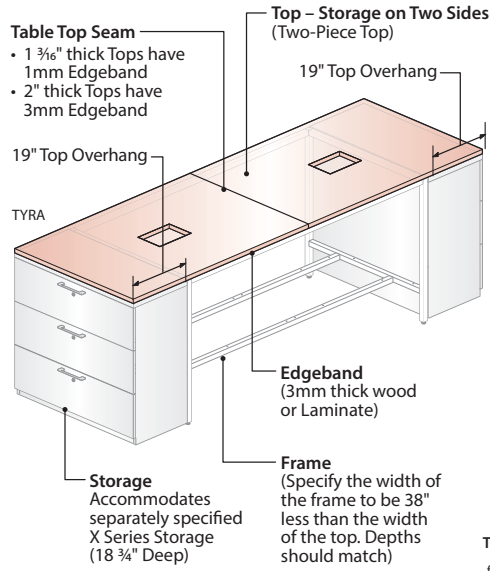

Storage on Two Sides Application

- Consists of the following separately specified components:
 - Cultivate Top - Storage on Two Sides (Two-Piece Top)
 - Cultivate Frame
 - (2) X Series Storage Units
- Top – Storage on Two Sides (Two-Piece Top) is pre-drilled to attach to a frame that is 38" less than the width of the top. The top will overhang the frame 19" on both sides.
- The Frame should be specified 38" less than the width of the Top and with the same depth as the top.
- Seated Height Frames are for use with 2H X Series Storage.
- Standing Height Frames are for use with 3H X Series Storage.

Dimensions

Top View

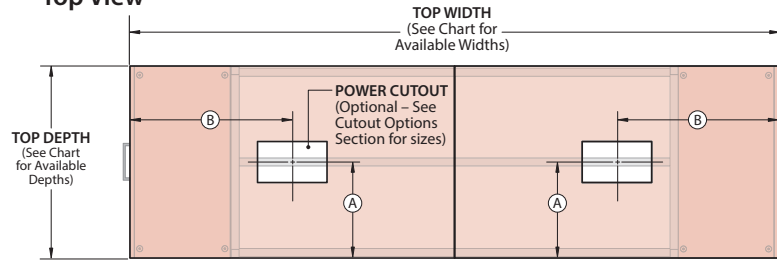

Wood Grain Direction



Wood Veneers

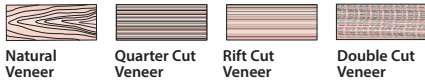

Top View

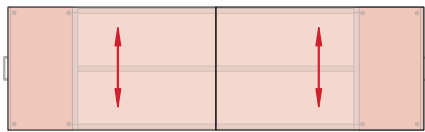

Wood Grain Laminate



Top View

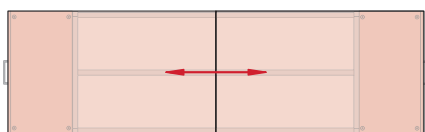

Front View – with Seated Height Frame

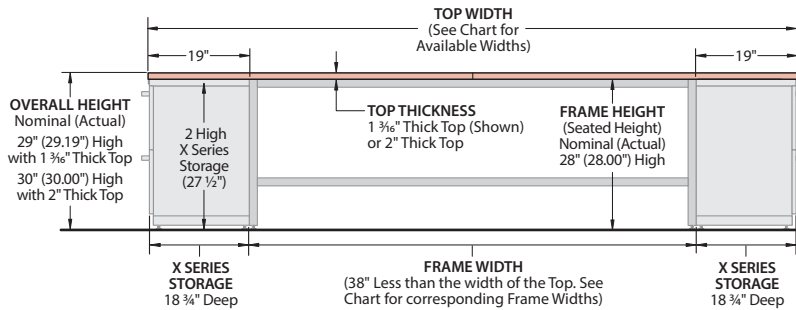

Front View – with Standing Height Frame

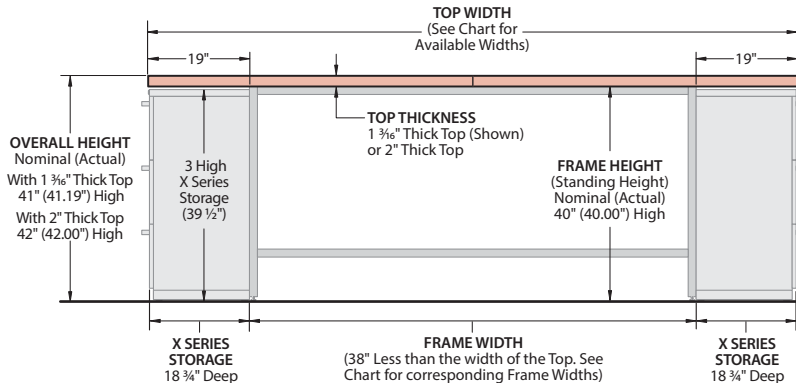

Note • Frames Glides provide 1 3/16" of vertical adjustment for leveling.

TOP		Number of Top Pieces	CUTOUT LOCATION		FRAME
DEPTH Nominal (Actual)	WIDTH Nominal (Actual)		A	B	Tops are Pre-Drilled to fit the corresponding Frame Sizes
36" (35.97")	122" (121.18")	2	18"	60 9/16"	84" Wide x 36" Deep
	134" (133.18")	2	18"	66 9/16"	96" Wide x 36" Deep
42" (41.97")	122" (121.18")	2	21"	60 9/16"	84" Wide x 42" Deep
	134" (133.18")	2	21"	66 9/16"	96" Wide x 42" Deep

Product Details – Cultivate Tables

Frame – Seated Height

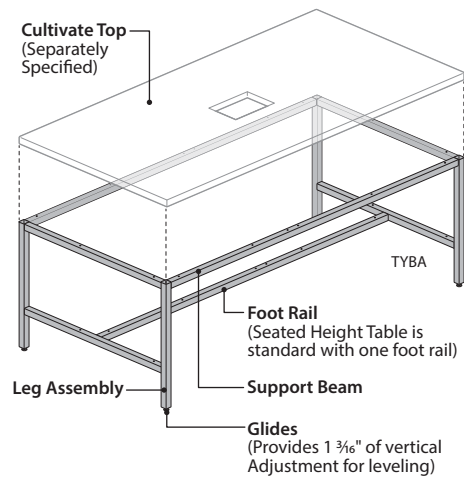

- Seated Height Frame is standard with (1) Foot Rail.
- Tops are allowed to overhang the frame (18" maximum overhang allowed per side).

Seated Height Frames – 28" High

- Specify with standard height chairs (17"-18" Seat Height).

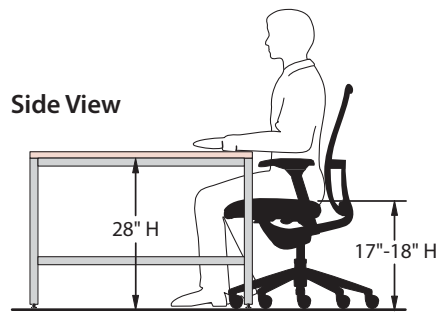

Component Materials/Finishes

COMPONENT NAME	MATERIALS/ FINISHES
Leg Assembly, Support Beam and Foot Rail	Painted Metal – Specify Frame Finish/Color
Glides	Standard in Black

Dimensions Top View

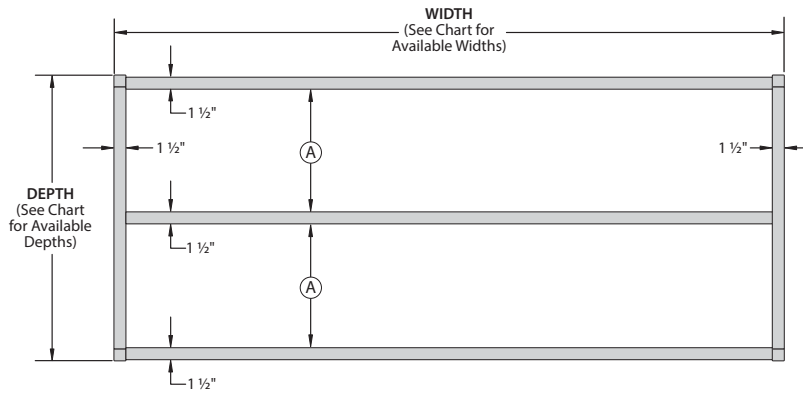

Front View

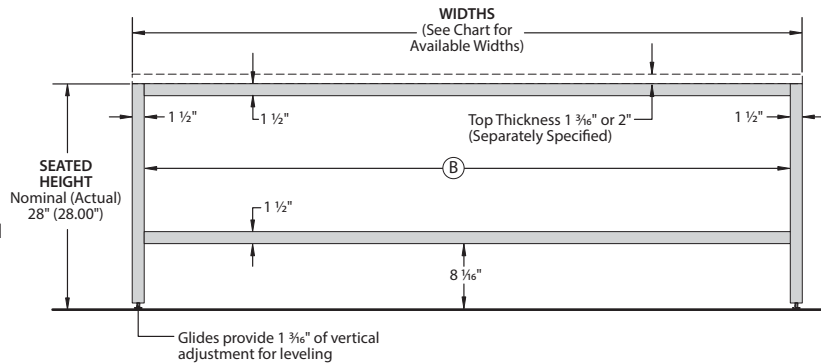

FRAME			
DEPTH Nominal (Actual)	WIDTH Nominal (Actual)	Ⓐ	Ⓑ
36" (35.73")	60" (59.44")	15 7/16"	56 7/16"
	72" (71.44")	15 7/16"	69 7/16"
	84" (83.44")	15 7/16"	81 7/16"
	96" (95.44")	15 7/16"	93 7/16"
42" (41.73")	60" (59.44")	18 7/16"	56 7/16"
	72" (71.44")	18 7/16"	69 7/16"
	84" (83.44")	18 7/16"	81 7/16"
	96" (95.44")	18 7/16"	93 7/16"

Product Details – Cultivate Tables

Frame – Standing Height

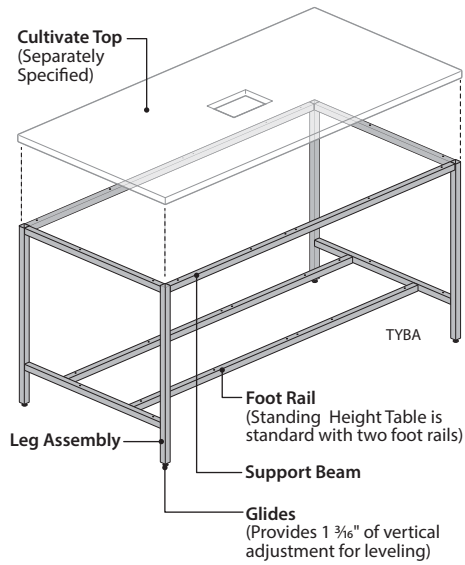

- Standing Height Frame is standard with (2) Foot Rails.
- Tops are allowed to overhang the frame (18" maximum overhang allowed per side).

Standing Height Frames – 40" High

- 40" high frames are for use with bar height stools or standing applications.
- Specify with bar height stools with 28"-30" seat heights.

Side View

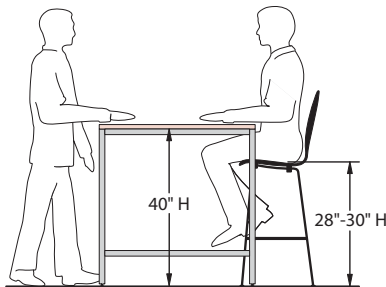

Component Materials/Finishes

COMPONENT NAME	MATERIALS/ FINISHES
Leg Assembly, Support Beam and Foot Rail	Painted Metal – Specify Trim Color
Glides	Standard in Black

Dimensions

Top View

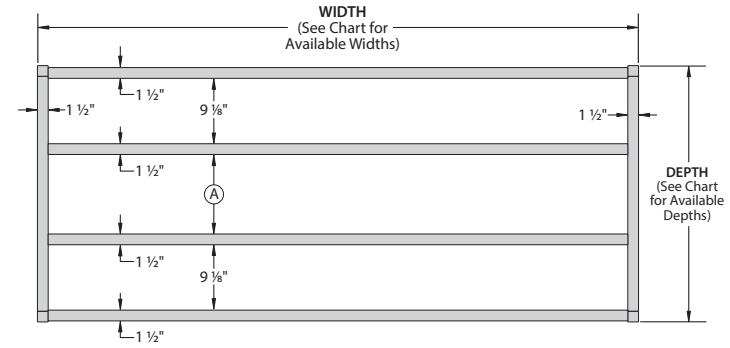

Front View

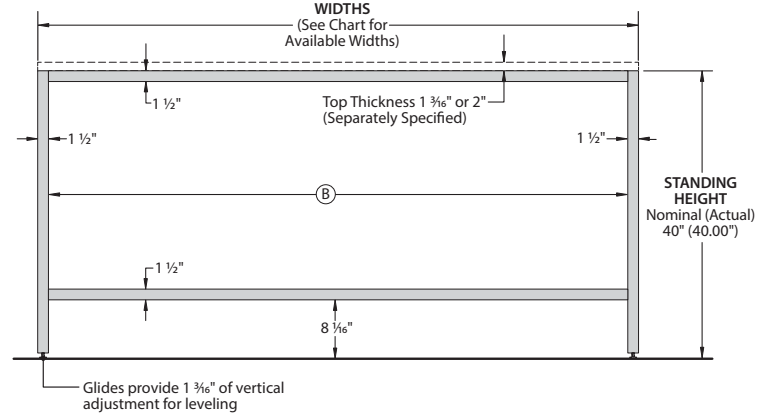

FRAME			
DEPTH Nominal (Actual)	WIDTH Nominal (Actual)	Ⓐ	Ⓑ
36" (35.73")	60" (59.44")	11 3/16"	56 7/16"
	72" (71.44")	11 3/16"	69 7/16"
	84" (83.44")	11 3/16"	81 7/16"
	96" (95.44")	11 3/16"	93 7/16"
42" (41.73")	60" (59.44")	17 3/16"	56 7/16"
	72" (71.44")	17 3/16"	69 7/16"
	84" (83.44")	17 3/16"	81 7/16"
	96" (95.44")	17 3/16"	93 7/16"

Product Details – Cultivate Tables

Accessories – Bag Hook

- Attaches to underside of 1 3/16" or 2" thick tops for hanging bags or other small items (50 lb. limit).
- Includes attachment hardware, the hook will swivel with installation of plastic washers.

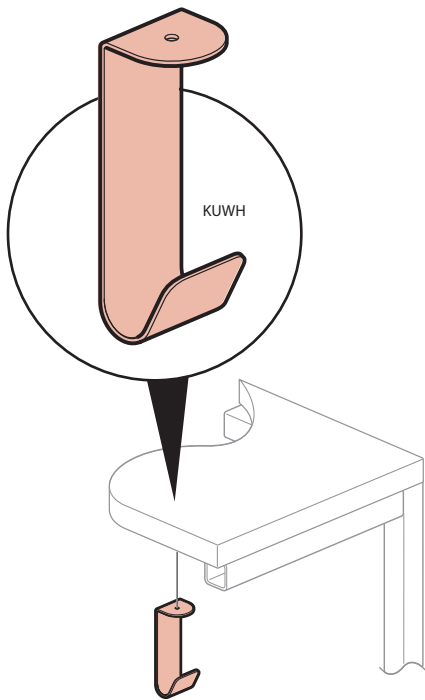

Component Materials/Finishes

COMPONENT NAME	MATERIALS/ FINISHES
Bag Hook	Painted Metal – Specified trim color.

Dimensions

Top View

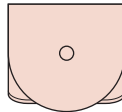

Front View

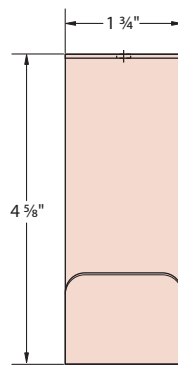

Side View



Kneespace Clearance

- Since the Bag Hook is designed to be mounted below the table top, ensure mounting location provides adequate clearance for users.

28" High Cultivate Frame (Side View)

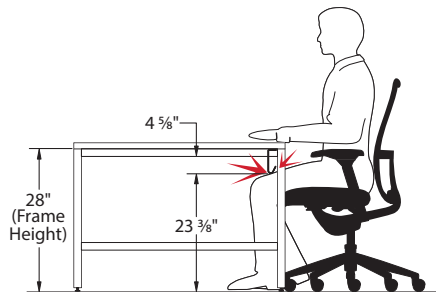

40" High Cultivate Frame (Side View)

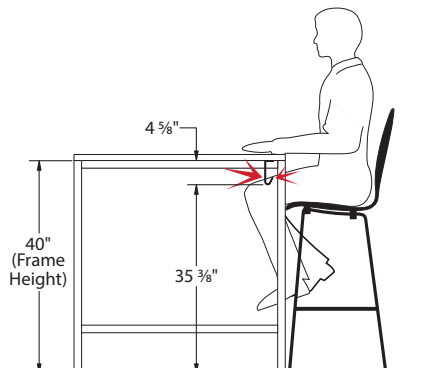

Product Details – Cultivate Tables

Electrical Components – Seamless Enhanced Power Module

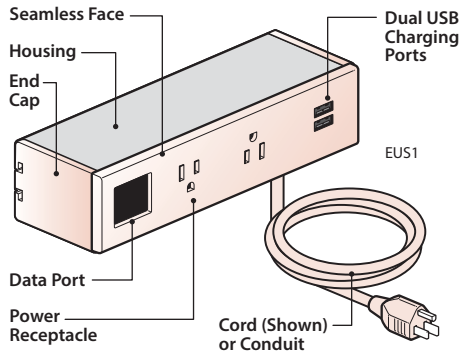

- Seamless Enhanced Power Modules provide Power, USB charging, Data or cable access in 2, 3, 4 or 5 port modules (See Price List for available configurations).
- Mounts to the underside/perimeter of the top, using a separately specified Bracket for Enhanced Power Modules (EUSB).
- Available with 6' or 12' cords or with flexible metal conduit.
- Power Modules specified with a data port includes a variety of data port adapters and blank covers, which accommodate most varieties of field supplied data/AV Jacks.

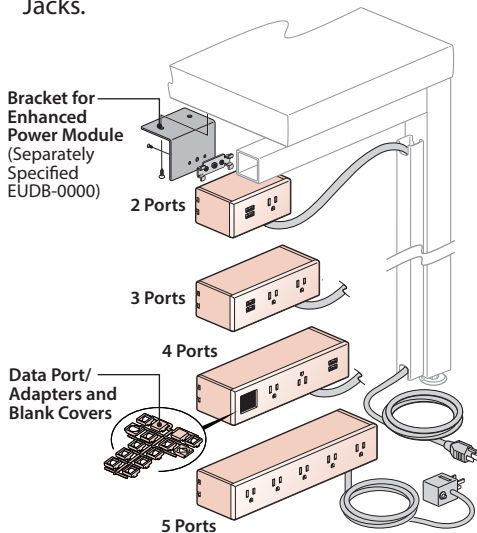

Kneespace Clearance

- When mounted below the table top, the Power Module will create issues for kneespace clearance. Ensure mounting location provides adequate clearance for users.

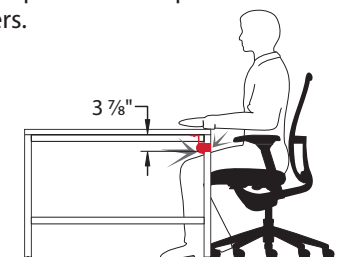

Component Materials/Finishes

COMPONENT NAME	MATERIALS/ FINISHES	
Seamless Face and End Caps	plastic which may be specified in white or black.	
Housing	Clear anodized aluminum.	
Cord / Conduit	Corded	• Cord with Plug matches Power Module color (black or white).
	Hardwired	• Includes 12' flexible galvanized metal conduit with fitting for 1/2" knockout and wires for hardwire connection.
Bracket for Seamless Enhance Power Module (Separately Specified)	Painted Metal – Available in white or black	

Wiring Options

- The Seamless Enhanced Power Module may be specified as corded or hardwired.
- Application may require approval of local authority having jurisdiction (AHJ); ensure compliance before placing orders and installation.

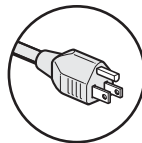

Corded with Standard Plug

- Included with corded units with (3) Power Receptacles or less.
- Features a 15 amp cord with Plug (NEMA 15-5P).
- Available with a 6' or 12' Long cord.
- Cord matches Power Module color (black or white).

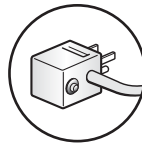

Corded with Circuit Breaker Plug

- Included with corded units with (4) Power Receptacles or more.
- May block adjacent building receptacle outlet.
- Features a 15 amp cord with Plug (NEMA 15-5P).
- Available with a 6' or 12' Long cord.
- Cord/Plug matches Housing/Seamless Face colors (black or white).

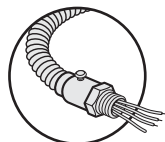

Hardwired

- Includes a 12' long flexible galvanized metal conduit with fitting for 1/2" knockout and wires for hardwire connection.

Dimensions

Side View

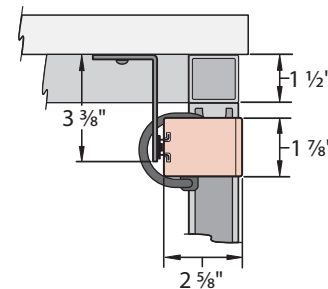

Front View

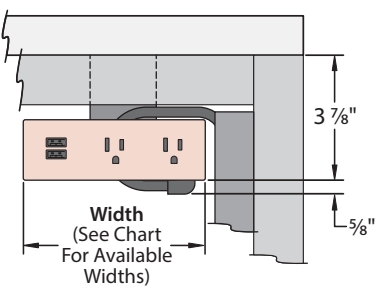

NUMBER OF PORTS	WIDTHS
2 Ports	4"
3 Ports	5 1/2"
4 Ports	7"
5 Ports	8 1/2"

Product Details – Cultivate Tables

Electrical Components – Wireless Charging Module

Dual Charging Pad

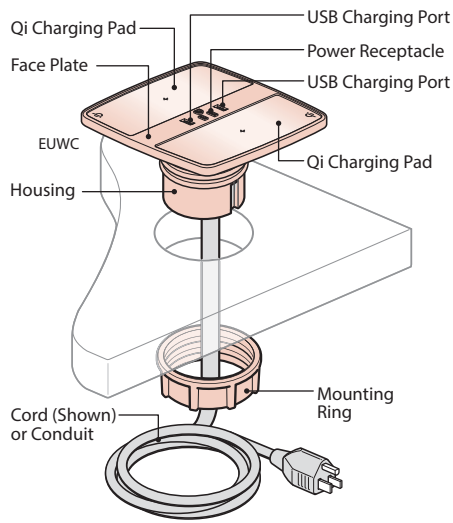

Single Charging Pad

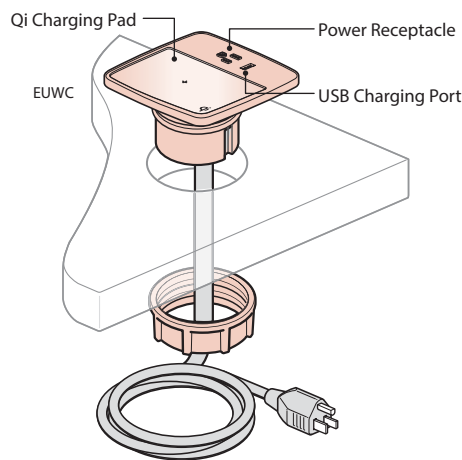

- Available with a Single Wireless Charging Pad, or Dual Wireless Charging Pads - compatible with all Qi-enabled smartphones and devices.
- The Dual Charging Pad includes:
 - (1) 15 Amp power receptacle
 - (2) 2.1 Amp USB charging ports
 - (2) Charging Pads each with a 5 Watt Charging Coil.
- The Single Charging Pad includes:
 - (1) 15 Amp power receptacle
 - (1) 2.1 Amp USB charging ports
 - (1) Charging Pads with a 5 Watt Charging Coil.

Cutout Size (Top View)

- The Wireless Charging Module requires a 3" diameter cutout (field cut) is required for mounting to the top.
- Accommodates tops from 3/4" to 1 1/2" thick (not for use with 2" thick tops).

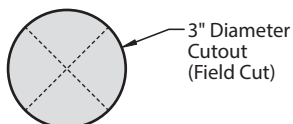

Component Materials/Finishes

COMPONENT NAME	MATERIALS/ FINISHES	
Face Plate and Housing	Black glossy plastic.	
	White glossy plastic.	
Charging Pad	Soft touch plastic inserts (matches Faceplate – black or white)	
Cord / Conduit	Corded	• Cord with Plug matches Faceplate/Housing color (black or white).
	Hardwired	• Includes 12' flexible galvanized metal conduit with fitting for 1/2" knockout and wires for hardwire connection.

Wiring Options

- The Wireless Charging Module may be specified corded or hardwired.
- Application may require approval of local authority having jurisdiction (AHJ); ensure compliance before placing orders and installation.

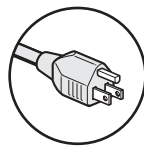

Corded with Standard Plug

- Included with corded units with (3) Power Receptacles or less.
- Features a 15 amp cord with Plug (NEMA 15-5P).
- Available with a 6' or 12' Long cord.
- Cord/Plug matches Face Plate color (black or white).

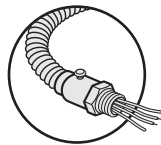

Hardwired

- Includes a 12' long flexible galvanized metal conduit with fitting for 1/2" knockout and wires for hardwire connection.

Dimensions

Dual Charging Pad Top View

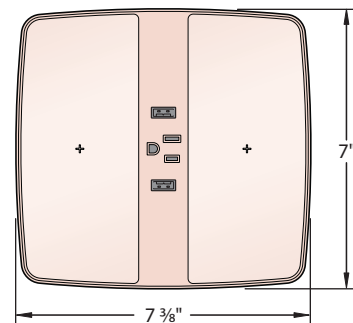

Side View

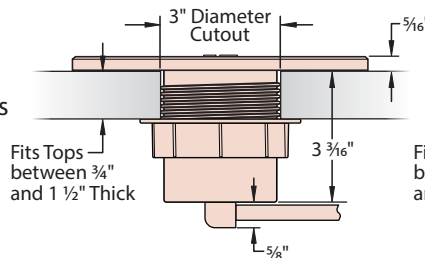

Single Charging Pad Top View

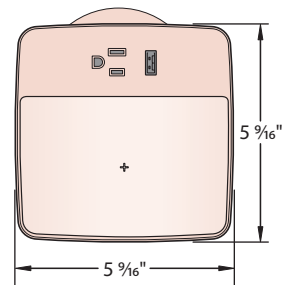

Side View

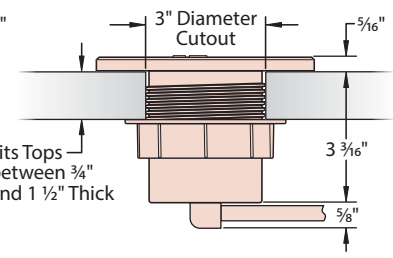

Note

- The brackets accommodate tops between 3/4" and 1 3/4" thick, the module cannot be used with 2" thick tops.

Product Details – Cultivate Tables

Electrical Components – Flush Mount Power Modules

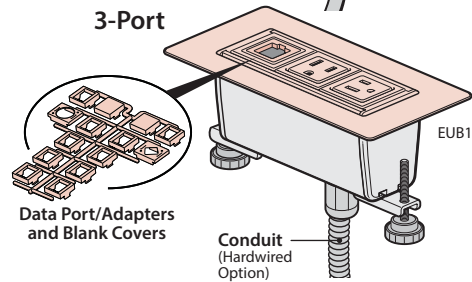
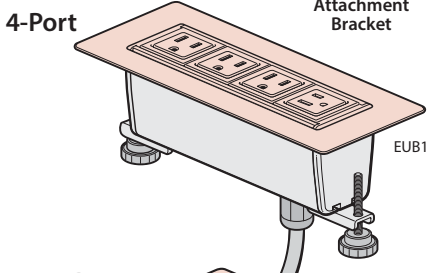
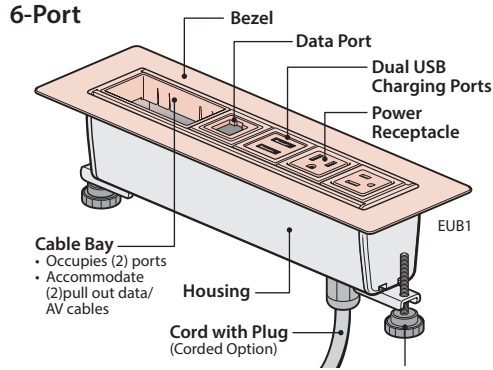

- Flush Mount Power Modules provide Power, USB charging, Data or cable access in 3, 4 or 6 port modules.
- Mounts flush to horizontal surfaces.
- Available with 6' or 12' cords or with flexible metal conduit.
- For use with tops between ¾" and 2" thick.
- Power Modules specified with a data port includes a variety of data port adapters and blank covers, which can accommodate most varieties of field supplied data/AV Jacks.

Cutout Sizes (Top View)

6-Port – Top Cutout Option (Z)

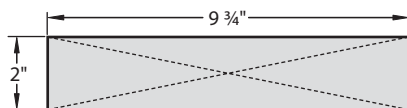

4-Port – Top Cutout Option (X)



3-Port – (Must be Field Cut)

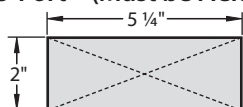

Component Materials/Finishes

COMPONENT NAME	MATERIALS/ FINISHES
Bezel and Receptacles	Black painted metal bezel and black plastic receptacles/ports.
	White painted metal bezel and white plastic receptacles/ports.
Housing	Clear Anodized Aluminum
Cord / Conduit	Corded <ul style="list-style-type: none"> • Cord with Plug matches Power Module color (black or white) with Plug.
	Hardwired <ul style="list-style-type: none"> • Includes 12' flexible galvanized metal conduit with fitting for ½" knockout and wires for hardwire connection.

Wiring Options

- The Flush Mount Enhanced Power Module may be specified as corded or hardwired.
- Application may require approval of local authority having jurisdiction (AHJ); ensure compliance before placing orders and installation.

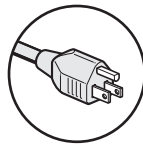

Corded with Standard Plug

- Included with corded units with (3) Power Receptacles or less.
- Features a 15 amp cord with Plug (NEMA 15-5P).
- Available with a 6' or 12' Long cord.
- Cord/Plug defaults to Bezel color (black or white).

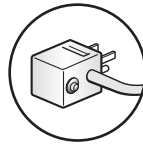

Corded with Circuit Breaker Plug

- Included with corded units with (4) Power Receptacles or more.
- May block adjacent building receptacle outlet.
- Features a 15 amp cord with Plug (NEMA 15-5P).
- Available with a 6' or 12' Long cord.
- Cord/Plug defaults to Bezel color (black or white).

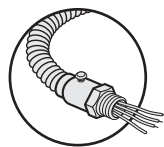

Hardwired

- Includes a 12' long flexible galvanized metal conduit with fitting for ½" knockout and wires for hardwire connection.

Dimensions

Top View

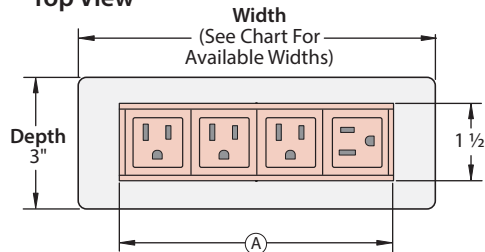

PORTS	WIDTHS	(A)
6 Port	11 ¼"	9 ¼"
4 Port	8 ½"	6 ¼"
3 Port	6 ¾"	4 ¼"

Front View

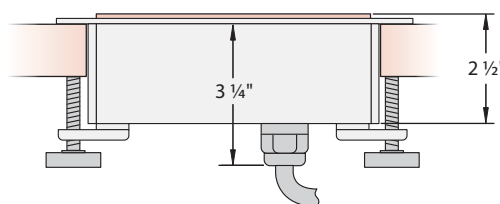

Side View

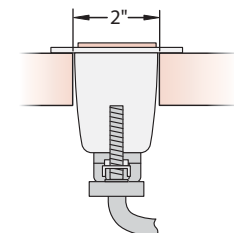

Note

- The brackets accommodate tops between ¾" and 1 ¾" thick, the module cannot be used with 2" thick tops.

Product Details – Cultivate Tables

Electrical Components – Flip Top Unit – Double Sided

12 Ports

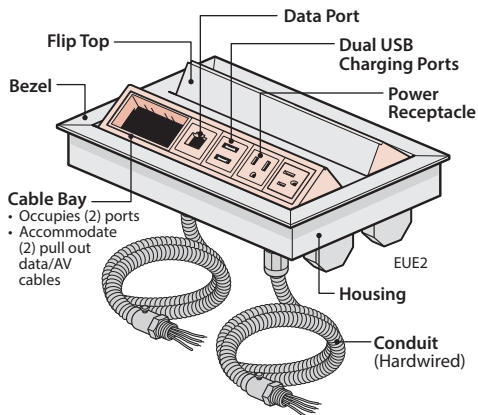

8 Ports

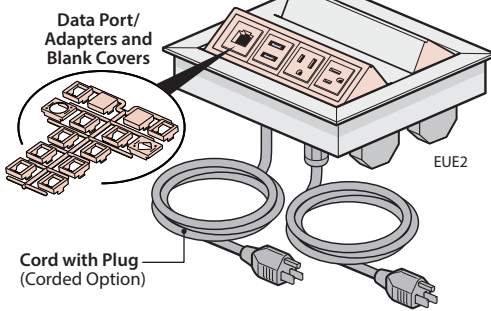

- Flip Top Units provide Power, USB charging, Data, A/V or cable access in 8, or 12 port modules .
- Mounts flush to horizontal surfaces.
- Available with cords or with flexible metal conduit (6' or 12' long).
- Mounting into 2" thick tops requires separately specified Mounting Clips (EUMC-0201)
- Units specified with a data port includes a variety of data port adapters and blank covers, which can accommodate most varieties of field supplied data/AV Jacks.

Cutout Sizes (Top View)

6-Port – Top Cutout Option (Q)

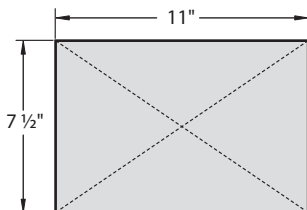

4-Port – Top Cutout Option (M)

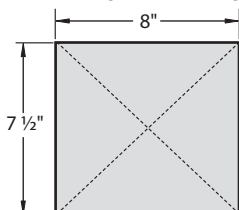

Component Materials/Finishes

COMPONENT NAME	MATERIALS/ FINISHES
Bezel, Flip Top, Housing and Receptacles/Ports	Clear anodized finish with white Receptacles/Ports
	Black anodized finish with Black outlets Receptacles/Ports
Cord / Conduit	Corded <ul style="list-style-type: none"> • Cord with Plug matches Power Module color (black or white) with Plug.
	Hardwired <ul style="list-style-type: none"> • Includes 12' flexible galvanized metal conduit with fitting for 1/2" knockout and wires for hardwire connection.

Wiring Options

- Each Flip Top Unit – Double Sided includes may be specified as corded or hardwired.
- Application may require approval of local authority having jurisdiction (AHJ); ensure compliance before placing orders and installation.

Corded with Standard Plug

- Included with corded units with (3) Power Receptacles or less.
- Features a 15 amp cord with Plug (NEMA 15-5P).
- Available with a 6' or 12' Long cord.
- Cord/Plug color defaults to white for units with a clear anodized finish, or black for units with a black anodized finish.

Corded with Circuit Breaker Plug

- Included with corded units with (4) Power Receptacles or more.
- May block adjacent building receptacle outlet.
- Features a 15 amp cord with Plug (NEMA 15-5P).
- Available with a 6' or 12' Long cord.
- Cord/Plug color defaults to white for units with a clear anodized finish, or black for units with a black anodized finish.

Hardwired

- Includes a 12' long flexible galvanized metal conduit with fitting for 1/2" knockout and wires for hardwire connection.

Dimensions

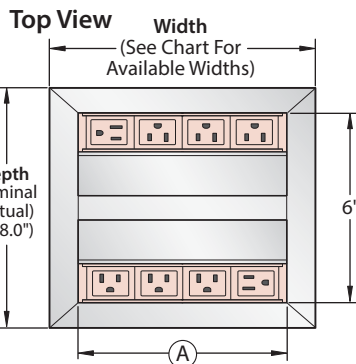

PORTS	WIDTH Nominal (Actual)	(A)	(B)
6 Ports (each side)	11" (11.31")	9 13/16"	10 13/16"
4 Ports (each side)	8" (8.31")	6 13/16"	7 13/16"

Front View

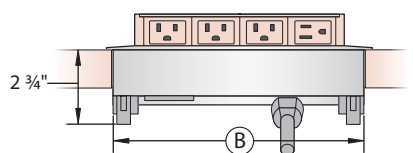

Side View

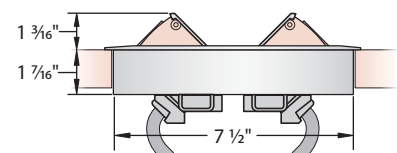

Note

- Installation on 2" thick tops require the separately specified Mounting Clips for Flip Top Units (EWWW-0601).

Product Details – Cultivate Tables

Wire Management – Vertical Wire Channel

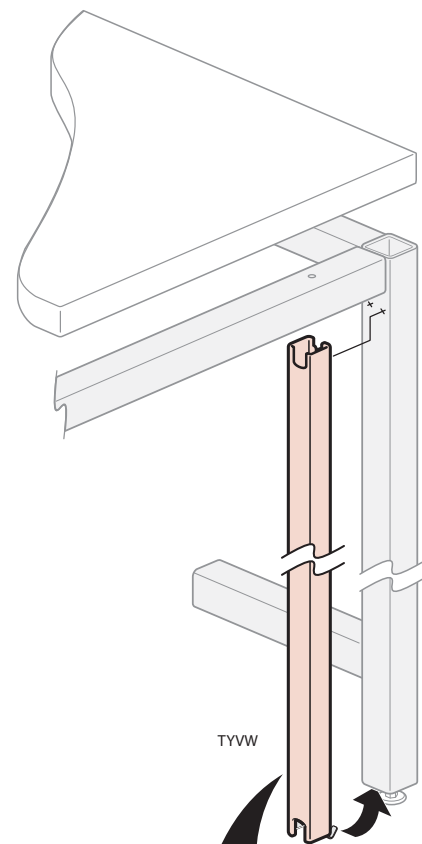

Component Materials/Finishes

COMPONENT NAME	MATERIALS/ FINISHES
Channel	Painted Metal – Specify Trim Color

Dimensions

Top View

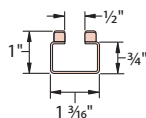

Height (Actual)	For Use With
25.7" High	28" High Frames
37.7" High	40" High Frames

Front View

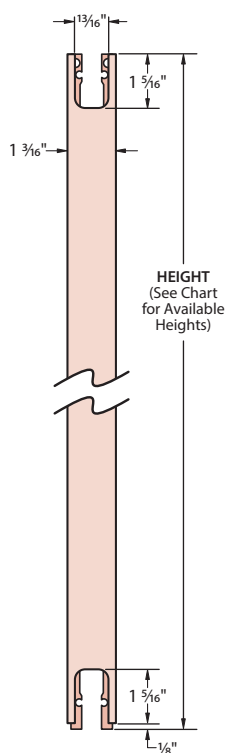

Side View

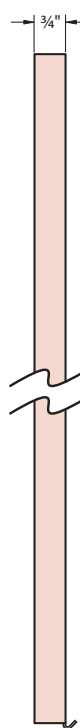

Back View

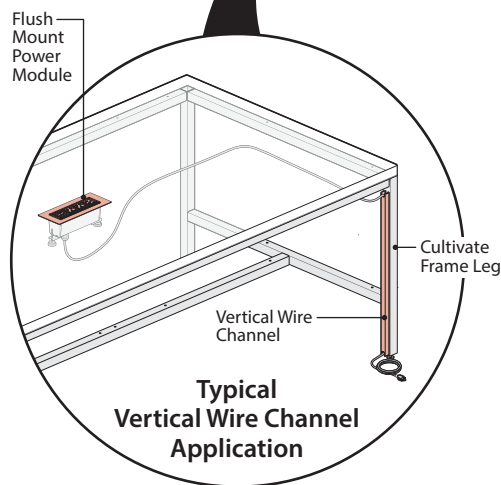
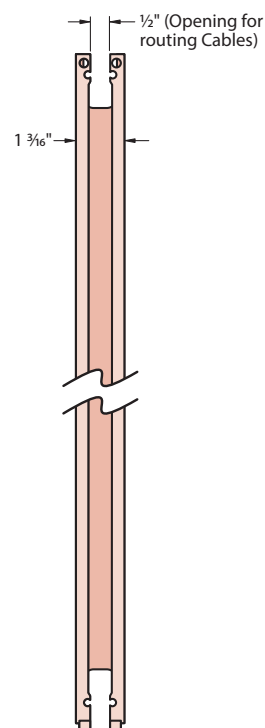

- The Vertical Wire Channel is designed to mount to the leg of a cultivate frame, providing vertical cable routing from the underside of the top down to the floor.
- Specify the height of the Channel to match the height of the frame leg (see chart above).
- Accommodates 2-3 cords/cables (depending on cable diameter) or one 1/2" Extra Flexible Conduit.
- Wires/cables should be routed through the opening in the back of the unit before installation.

Product Details – Cultivate Tables

Wire Management – Wire Management Basket

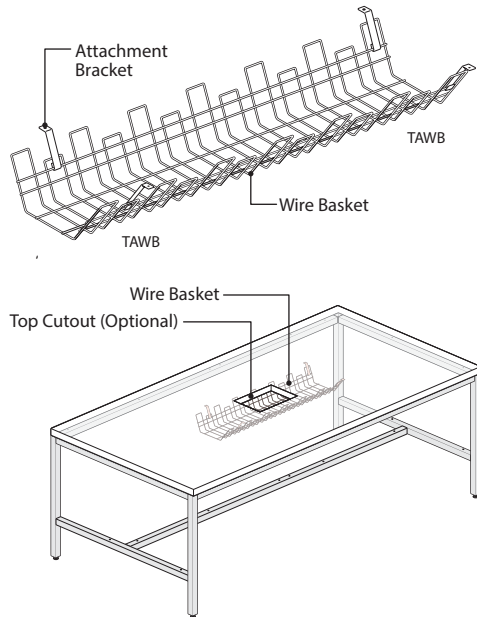

- The Wire Management Basket is designed to provide additional wire management and storage.
- Attaches to underside of top and is accessible from both sides.
- May be detached from the table without tools.

Accessories – Basket Cover

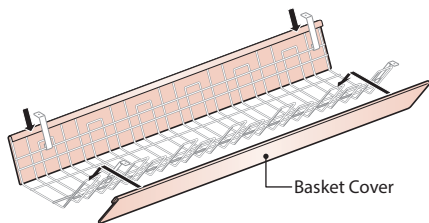

- The separately specified Basket Cover encloses a side of the basket to provide a more finished aesthetic.
- A Basket Cover can be added to each side of the basket.
- Specify width to match Basket width.
- The covers are painted metal, and may be specified with a trim color to match the table base or with a coordinating color.
- Each Basket Cover is separately specified.

Component Materials/Finishes

COMPONENT NAME	MATERIALS/ FINISHES
Wire Bracket and Attachment Bracket	Painted Metal –Standard in Black

Dimensions

Front View

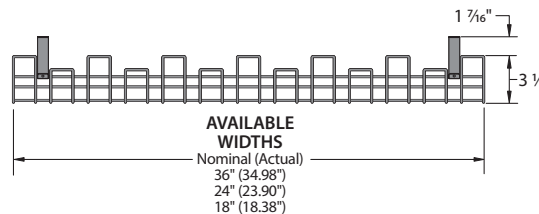

Side View

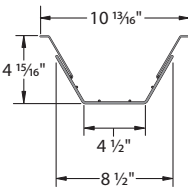

Kneespace Clearance

- In order to provide adequate kneespace clearance, the recommended mounting location for the basket is centered on the depth of the table.
- Always provide adequate kneespace when positioning components below the table top. Ensure mounting bracketry does not interfere with the frame, power cutouts or other accessories.

28" High Cultivate Frame (Side View)

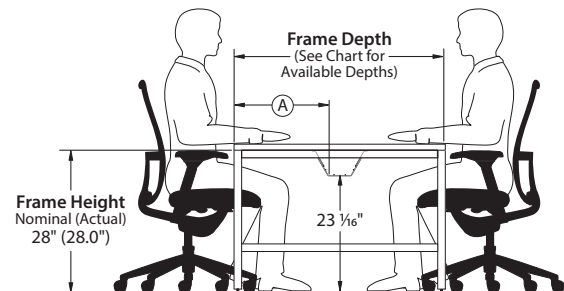

40" High Cultivate Frame (Side View)

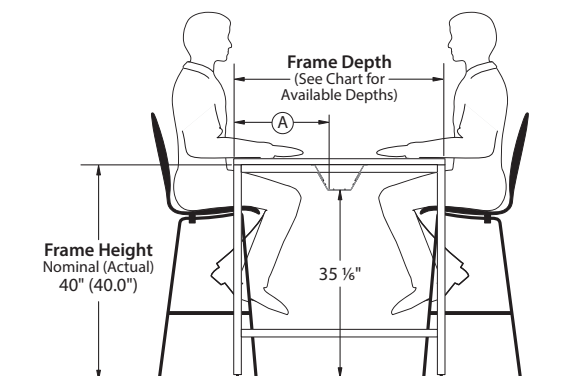

FRAME DEPTH Nominal (Actual)	(A)
36" (35.73")	15 5/8"
42" (41.73")	18 5/8"

This page intentionally left blank.

Specification Guide – Cultivate Tables Product Application Section

Product Application – Cultivate Tables

Overview

- Cultivate Tables easily support multiple functions that bring people together.
- Frames and tops are specified separately to offer unique applications when designing your collaborative environments.
- Cultivate Tables support a variety of power applications including two factory installed power solutions and two field installed power solutions.
- If a more customized or unique design is required, Haworth's Tailored Solutions team is prepared to assist.

Standard Applications

- Pre-drilled Tops are designed for installation on coordinating Frame sizes to create four standard applications.

No Storage – Top Flush to Frame Application

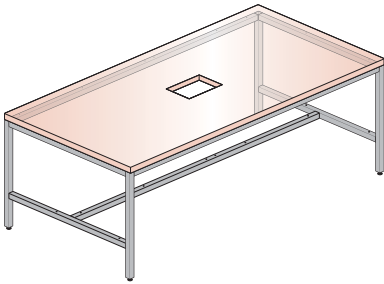

No Storage – Top Overhanging Frame Application

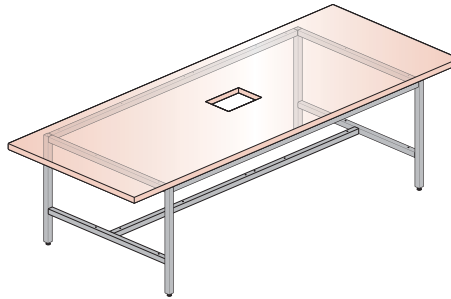

Storage on One Side Application

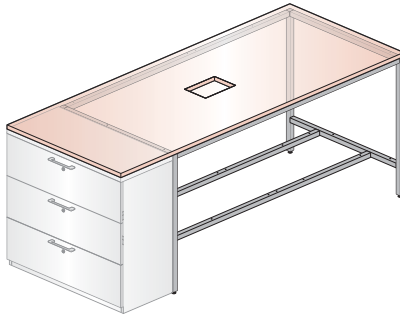

Storage on Two Sides Application

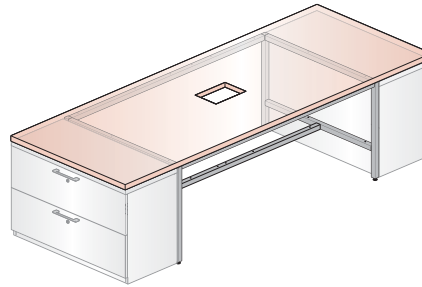

Custom Applications

- Tops may be installed on non-coordinating frames sizes to create custom applications (pre-drilled holes in the top will not align with the holes in the frame).
- **Tops may not overhang the frame more than 18"** (unless the overhang is supported by storage).

No Storage – Overhanging Frame on One Side/
Flush To Frame on One Side

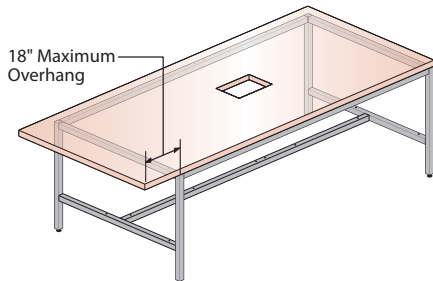

Storage on One Side/Overhanging Frame
on One Side

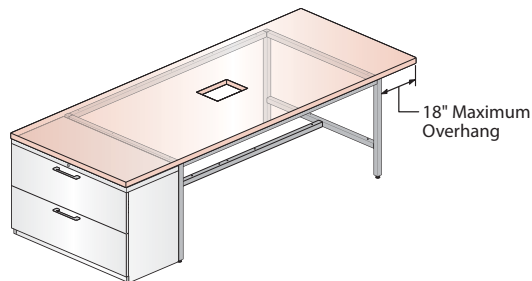

Product Application – Cultivate Tables

Specifying Cultivate Tables In Five Easy Steps

Overview

- Adhere to the following easy steps to properly specify a Cultivate Table application.

Step 1: Specify Top

Step 2: Specify Frame

Step 3: Specify Storage (Optional)

Step 4: Specify Power Components (Optional)

Step 5: Specify Wire Management Components (Optional)

Additional Design Considerations

- **How will the table be used?**
 - Conference Space
 - Community Space
 - Project Space
 - Touch Down Space
 - Training Space
 - Cafe Space
- **How many people will be using the table?**
 - See seating capacity charts in Product Details Section to determine adequate table size.
- **Is the table used for standing or seated activities?**
 - Specify seated or standing height Frames accordingly.
- **Does the application require storage?**
 - Cultivate tables are designed for use with 2H and 3H X Series Storage 36" and 42" wide by 18 3/4" deep, Proud Front storage. X Series Inset Front storage also works, but have a different alignment aesthetic.
- **Will the application require power, data or charging?**
 - Review available power modules to find the component that best meets the needs of the application.
 - Identify how the table will be connected to the building power and where the table should be located in the space to access it (floor access, wall access, column access/corded, or hardwired).
 - Determine location of the power/data components in the table (centered on the top/below the worksurface on the perimeter, etc.).
 - Specify wire management components to keep all cords and cables neat and organized.

Building Power Locations

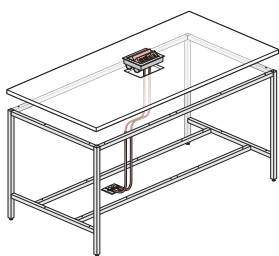

Floor Access – Building Power

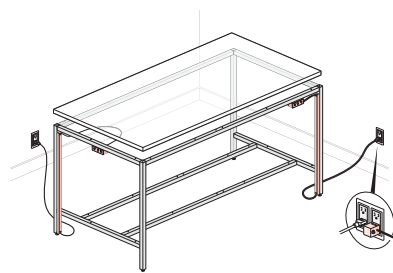

Wall Access – Building Power

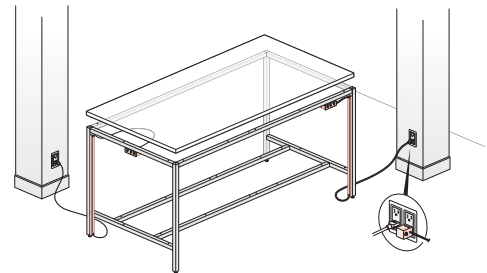

Column Access – Building Power

Product Application – Cultivate Tables

Specifying Cultivate Tables In 5 Easy Steps

Step 1 – Specify Top

Choose Top Thickness

- 1 3/16" or 2" Thick

Choose Top Depth

- 36" Deep or 42" Deep

Choose Top Width

(Widths vary by application)

- No Storage Applications:
 - Flush to Frame (60", 72", 84" or 96" Wide)
 - Overhanging Frame (108" or 120" Wide)
- Storage Applications:
 - Storage on One Side (79", 91", 103" or 115" Wide)
 - Storage on Two Sides (98", 110", 122" or 134" Wide)

Specify Surface and Edge Options

- (L) Laminate / (J) Edgeband (Laminate)
- (W) Wood / (K) Edgeband (Wood)

Specify Power Cutout Option

- (N) No Cutout
- (X) Center Cutout – Flush Mount Power Module – 4 Port
- (Z) Center Cutout – Flush Mount Power Module – 6 Port
- (M) Center Cutout – Flip Top Unit – Double Sided – 8 Port
- (Q) Center Cutout – Flip Top Unit – Double Sided – 12 Port

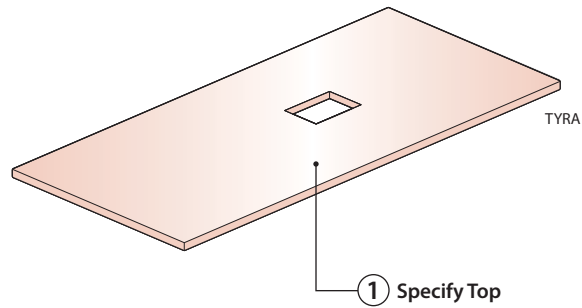

Step 2 – Specify Frame

Choose Frame Height:

- Seated Height (28" High)
- Standing Height (40" High)

Choose Frame Depth

- 36" or 42" Deep (*match Top depth*)

Choose Frame Width

(Widths will vary by application)

- No Storage Applications:
 - Flush to Frame (60", 72", 84" or 96" Wide)
Frame width is the same as Top width
 - Overhanging Frame (84" or 96" Wide)
Frame width is 24" less than Top width
- Storage Applications:
 - Storage on One Side (60", 72", 84" or 96" Wide)
Frame width is 19" less than Top width
 - Storage on Two Sides (60", 72", 84" or 96" Wide)
Frame width is 38" less than Top width

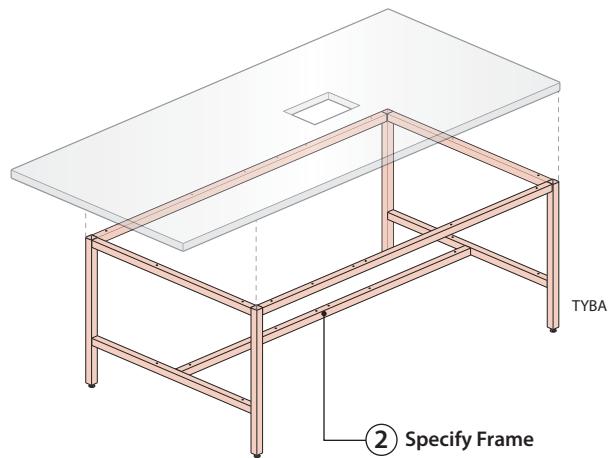

Step 3 – Specify Storage (Optional)

Storage applications are designed to accommodate X Series Proud Front Storage (2H for Seated Height or 3H for Standing Height/36" or 42" wide). Specify appropriate Top to accommodate storage (Top for storage on one side or Top for storage on two sides).

Choose 2H or 3H X Series Storage Unit:

- Lateral File
- Storage Cabinets
- Combination Unit
- Double or Triple Group Lockers (36" wide/standing height applications only)
- Cubby Lockers (36" wide/standing height applications only)

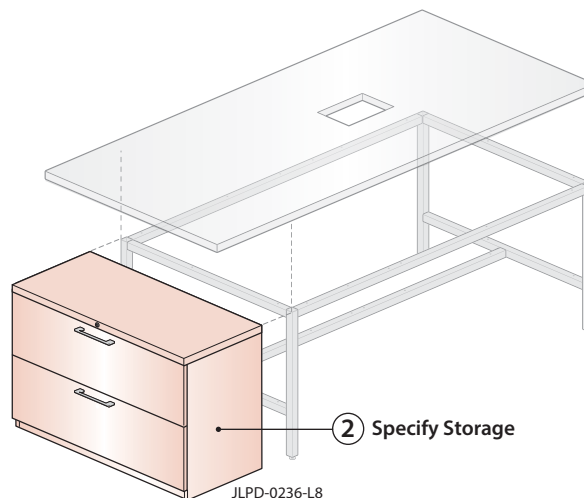

Product Application – Cultivate Tables

Specifying Cultivate Tables In 5 Easy Steps

Step 4 – Specify Electrical Components (Optional)

Cultivate may be used with a variety of Electrical Components to meet users power and data needs.

Choose Electrical Components

- Flush Mount Power Module
 - Tops may be specified with cutouts for 4 or 6 port modules, all other configurations require field cutting of the top.
- Flip Top Unit
 - Tops may be specified with cutouts for 8 or 12 port dual sided Flip Top Units, all other configurations require field cutting of the top.
 - 2" thick tops require separately specified Mounting Clip for Flip Top Units.
- Seamless Enhanced Power Modules
 - Requires separately specified Enhanced Power Module Bracket for mounting.
- Wireless Charging Module
 - Requires a field installed 3" diameter cutout, not for use with 2" thick top.

Note • See the Accessories Price Book for additional Electrical Components.

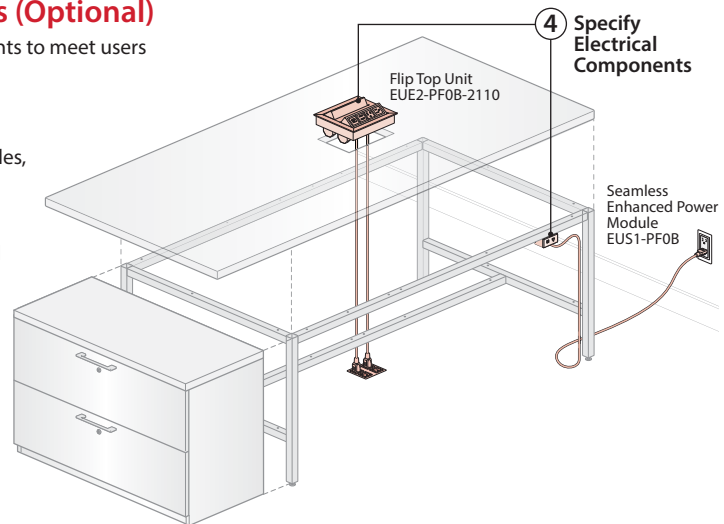

Step 5 – Specify Wire Management Components (Optional)

A variety of wire management tools are available for Cultivate Tables to manage cords and cables.

Choose Wire Management Components

- Vertical Wire Channel
- Cord Manager Mesh
- Cord Vertical Cable Chain
- Wire Management Basket
- See Accessories Price Book for additional Wire Management Components.

Note • See the Accessories Price Book for additional Wire Management Components.

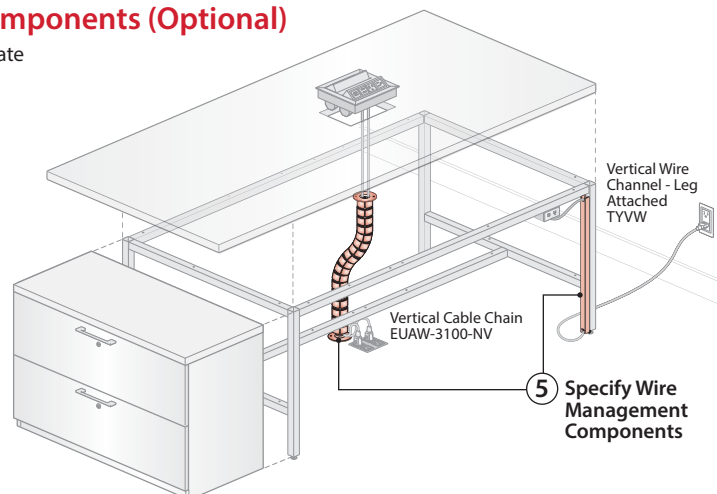

Product Application – Cultivate Tables

Standard Cultivate Table Applications

No Storage – Top Flush to Frame Application

- Do** Specify Top with the same width and depth as the frame.
- Tops are pre-drilled to be installed on frames with the same width and depth.
 - Tops are 1-Piece and do not overhang the frame or accommodate storage.
 - Tops are available 1 3/16" thick or 2" thick. Depending on the top thickness chosen, tops will provide an overall surface height of 29"/30" or 41"/42".

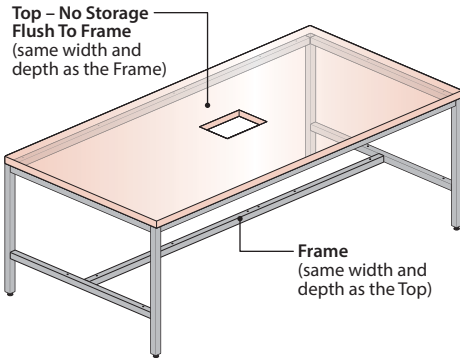

TOP			FRAME
DEPTH Nominal (Actual)	WIDTH Nominal (Actual)	Number of Top Pieces	Tops are Pre-Drilled to fit the corresponding Frame Sizes
36" (35.97")	60" (59.68")	1	60" Wide x 36" Deep
	72" (71.68")	1	72" Wide x 36" Deep
	84" (83.68")	1	84" Wide x 36" Deep
	96" (95.68")	1	96" Wide x 36" Deep
42" (41.97")	60" (59.68")	1	60" Wide x 42" Deep
	72" (71.68")	1	72" Wide x 42" Deep
	84" (83.68")	1	84" Wide x 42" Deep
	96" (95.68")	1	96" Wide x 42" Deep

No Storage – Top Overhanging Frame Application

- Do** Specify Top with 12" Overhang on both ends of the Frame.
- Specify Top 24" wider than the frame width to provide a 12" overhang at each end of the table (Top depth should match the depth of the frame).
 - Tops are pre-drilled to be installed on the frames with a 12" overhang on each end (See chart for corresponding Frame width for each top).
 - Tops are 1-piece and not designed to accommodate storage.
 - Tops are available 1 3/16" thick or 2" thick. Depending on the top thickness chosen, tops will provide an overall surface height of 29"/30" or 41"/42".

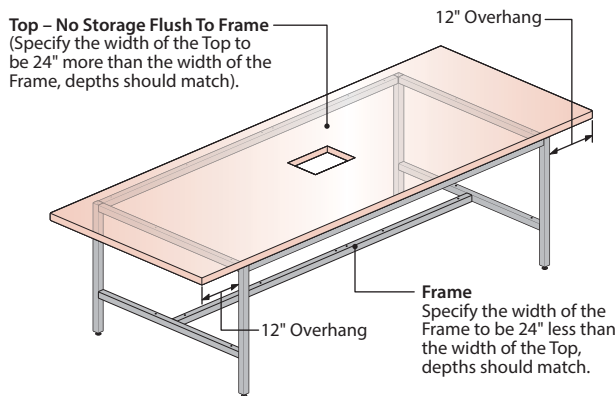

TOP			FRAME
DEPTH Nominal (Actual)	WIDTH Nominal (Actual)	Number of Top Pieces	Tops are Pre-Drilled to fit the corresponding Frame Sizes
36" (35.97")	108" (107.68")	1	84" Wide x 36" Deep
	120" (119.68")	1	96" Wide x 36" Deep
42" (41.97")	108" (107.68")	1	84" Wide x 42" Deep
	120" (119.68")	1	96" Wide x 42" Deep

Product Application – Cultivate Tables

Standard Cultivate Table Applications

Storage on One Side Application



Specify Top with 19" Overhang on one end to accommodate Storage

- Specify Top 19" wider than the Frame width to provide a 19" overhang on one end of the table to accommodate X Series Storage (Top depth should match the depth of the frame).
- Tops are pre-drilled to be installed on frames with a 19" overhang on one end (See chart for corresponding Frame size for each top).
- Tops are 1-Piece and overhang the frame to accommodate 18 ¾" deep X Series Storage.
- Tops are available 1 ⅜" thick or 2" thick. Depending on the top thickness chosen, tops will provide an overall surface height of 29"/30" or 41"/42".
- Storage applications are designed to accommodate separately specified 18 ¾" deep X Series Proud Front Storage Units. Specify 2H units for Seated Height applications or 3H units for Standing Height applications.
- **The 19" overhangs cannot be unsupported, storage is required below the overhang for support.**

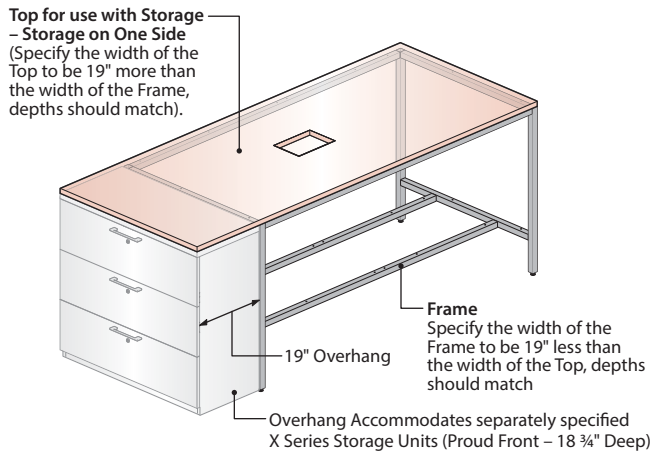

TOP			FRAME
DEPTH Nominal (Actual)	WIDTH Nominal (Actual)	Number of Top Pieces	Tops are Pre-Drilled to fit the corresponding Frame Sizes
36" (35.97")	79" (78.43")	1	60" Wide x 36" Deep
	91" (90.43")	1	72" Wide x 36" Deep
	103" (102.43")	1	84" Wide x 36" Deep
	115" (114.43")	1	96" Wide x 36" Deep
42" (41.97")	79" (78.43")	1	60" Wide x 42" Deep
	91" (90.43")	1	72" Wide x 42" Deep
	103" (102.43")	1	84" Wide x 42" Deep
	115" (114.43")	1	96" Wide x 42" Deep

Storage on Two Sides Application



Specify Top with 19" Overhang on both ends to accommodate Storage

- Specify Top 38" wider than the frame width to provide 19" overhangs on each end of the table (Top depth should match the depth of the frame).
- Tops are pre-drilled to be installed on frames with 19" overhangs on both ends. (See chart for corresponding Frame width for each top).
- 98" and 110" wide Tops are 1-Piece and 122" and 134" Tops are 2-Pieces, each top overhangs the frame to accommodate (2) 18 ¾" deep X Series Storage Units.
- Tops are available 1 ⅜" thick or 2" thick. Depending on the top thickness chosen, tops will provide an overall surface height of 29"/30" or 41"/42".
- Storage applications are designed to accommodate separately specified 18 ¾" deep X Series Proud Front Storage Units. Specify 2H units for Seated Height applications or 3H units for Standing Height applications.
- **The 19" overhangs cannot be unsupported, storage is required below the overhang for support.**

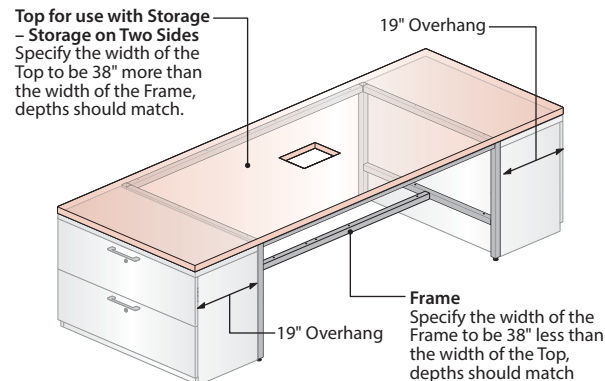

TOP			FRAME
DEPTH Nominal (Actual)	WIDTH Nominal (Actual)	Number of Top Pieces	Tops are Pre-Drilled to fit the corresponding Frame Widths
36" (35.97")	98" (97.18")	1	60" Wide x 36" Deep
	110" (109.18")	1	72" Wide x 36" Deep
42" (41.97")	98" (97.18")	1	60" Wide x 42" Deep
	110" (109.18")	1	72" Wide x 42" Deep

Product Application – Cultivate Tables

Standard Cultivate Table Applications

Storage Applications – Specifying Storage Units

- ✓ Do** Seated Height Storage Applications require separately specified 2H X Series Storage Units.
- Height – Seated Height applications require 28" high storage units (2H).
 - Depth – Storage applications require 18 ¾" deep X Series Storage (Proud Style).
 - Width – Storage width should match the depth of the table application (36" or 42").

Seated Height (2H) – Storage on One Side Application

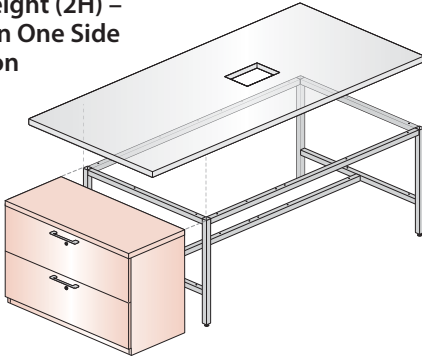

Seated Height (2H) – Storage on Two Sides Application

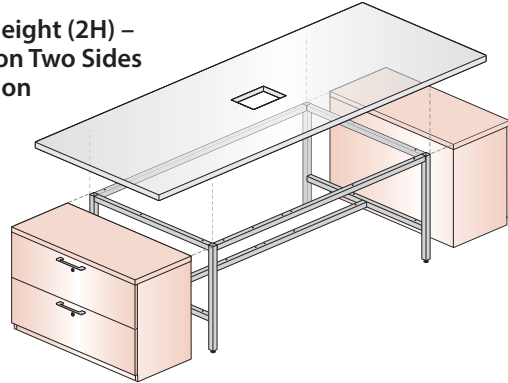

Recommended Storage Units for use with Seated Height (2H) Storage Applications:

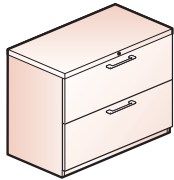

X Series – 2H Lateral File Proud Style
36" Wide – JLPD-0236
42" Wide – JLPD-0242

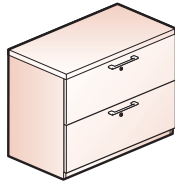

X Series – 2H Lateral File Proud Style with Individually Locking Drawers
36" Wide – JLPW-0236-5
42" Wide – JLPW-0242-5

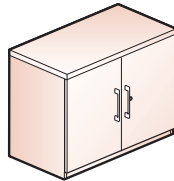

X Series – 2H Storage Cabinet
36" Wide – JSPY-0236
42" Wide – JSPY-0242

- Note**
- Freestanding or Attached Storage Units may be used.
 - Inset Style X Series Lateral Files (18" Deep) may be used, but will be inset from the top edge.

✗ Don't 19" top overhangs cannot be unsupported.

- Tops designed for storage applications create a 19" overhang to accommodate separately specified X Series Storage Units.
- The maximum top overhang allowed is 18", therefore 19" overhangs require storage below the top for support.

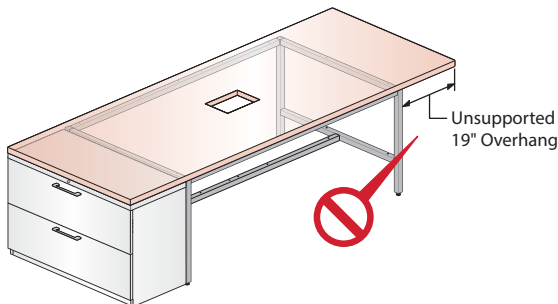

Product Application – Cultivate Tables

Standard Cultivate Table Applications

Storage Applications – Specifying Storage Units

- Do** Standing Height Storage Applications require separately specified 3H X Series Storage Units.
- Height – Seated Height applications require 40" high storage units (3H).
 - Depth – Storage applications require 18 ¾" deep X Series Storage (Proud Style).
 - Width – Storage width should match the depth of the table application (36" or 42").

Standing Height (3H) –
Storage on One Side
Application

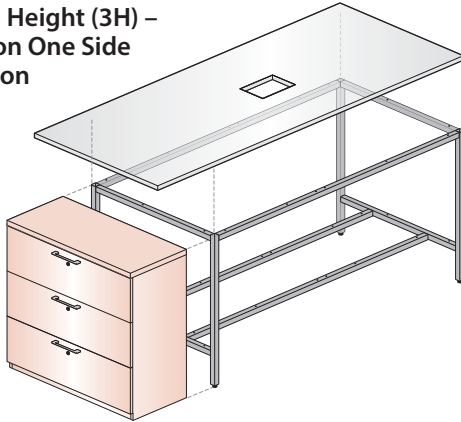

Standing Height (3H) –
Storage on Two Sides
Application

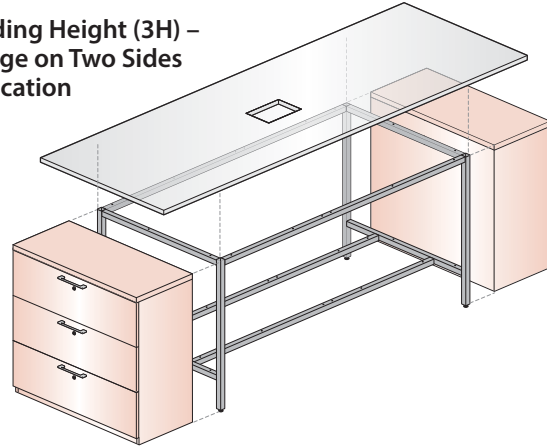

Recommended Storage Units for use with Seated Height (2H) Storage Applications:

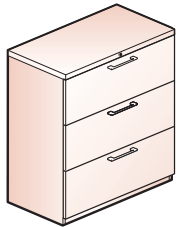

3H Lateral File – Proud Style
36" Wide – JLPD-0336
42" Wide – JLPD-0342

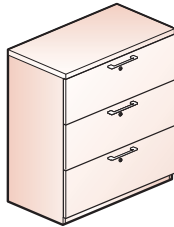

3H Lateral File with Individually Locking Drawers
36" Wide – JLPW-0336-S
42" Wide – JLPW-0342-S

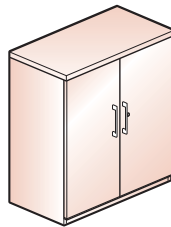

3H Storage Cabinet
36" Wide – JSPY-0336
42" Wide – JSPY-0342

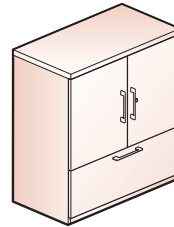

3H Combination Unit – 24" High Storage/ One Lateral
36" Wide – JCPV-0336
42" Wide – JCPV-0342

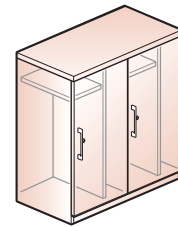

Double Group Locker
36" Wide – JA18-0336
42" Wide (not available)

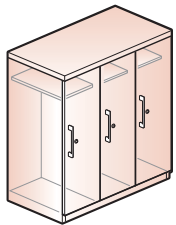

Triple Group Locker
36" Wide – JA18-0336
42" Wide (not available)

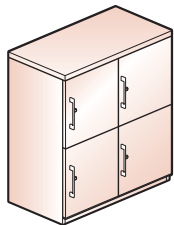

Cubby Lockers Four Doors
36" Wide – JA18-0336-A
42" Wide (not available)

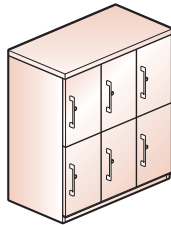

Cubby Lockers Six Doors
36" Wide – JA18-0336-G
42" Wide (not available)

- Note**
- Freestanding or Attached Storage Units may be used.
 - Inset Style X Series Lateral Files (18" Deep) may be used, but will be inset from the top edge.

Product Application – Cultivate Tables

Power/Data and Wire Management Applications

Table Top Power and Data Applications

- ✔ **Do**
 - Specify Tops with appropriate factory cutouts to accept either Flush Mounted Power or the Flip Top Units – Double-sided.
 - Specify appropriate wire management components to route cords and cables.

TABLE APPLICATION	Seated Height/Storage on One Side
BUILDING POWER	Located on the floor, centered under table.
POWER MODULE	Flush Mount Power Module (6 Port)
WIRE MANAGEMENT	Cord Manager Mesh or Vertical Cable Chain

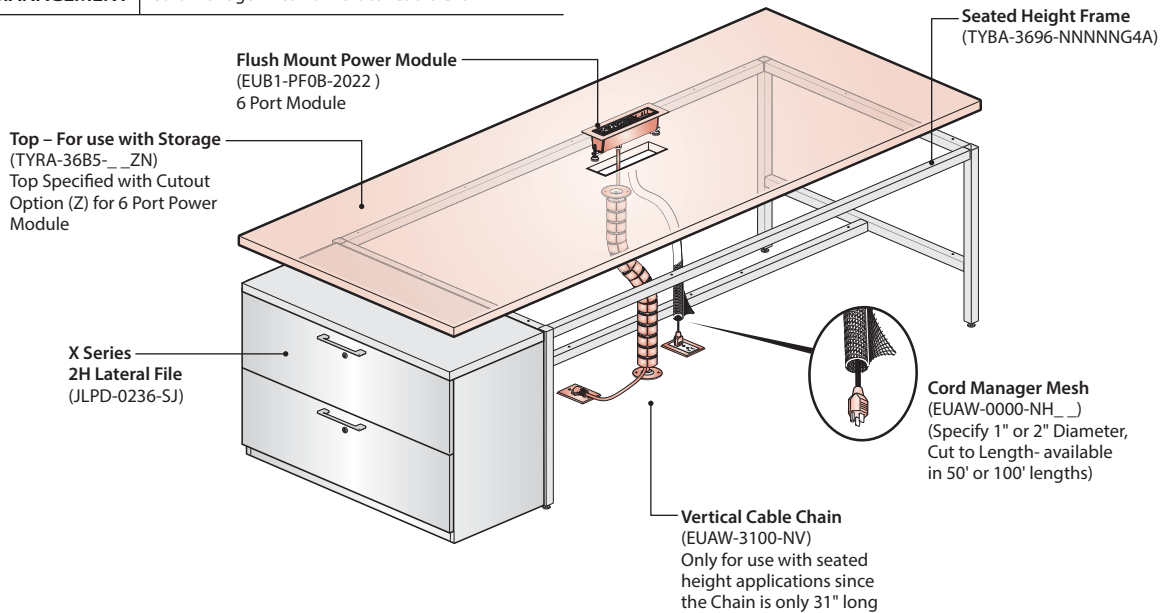
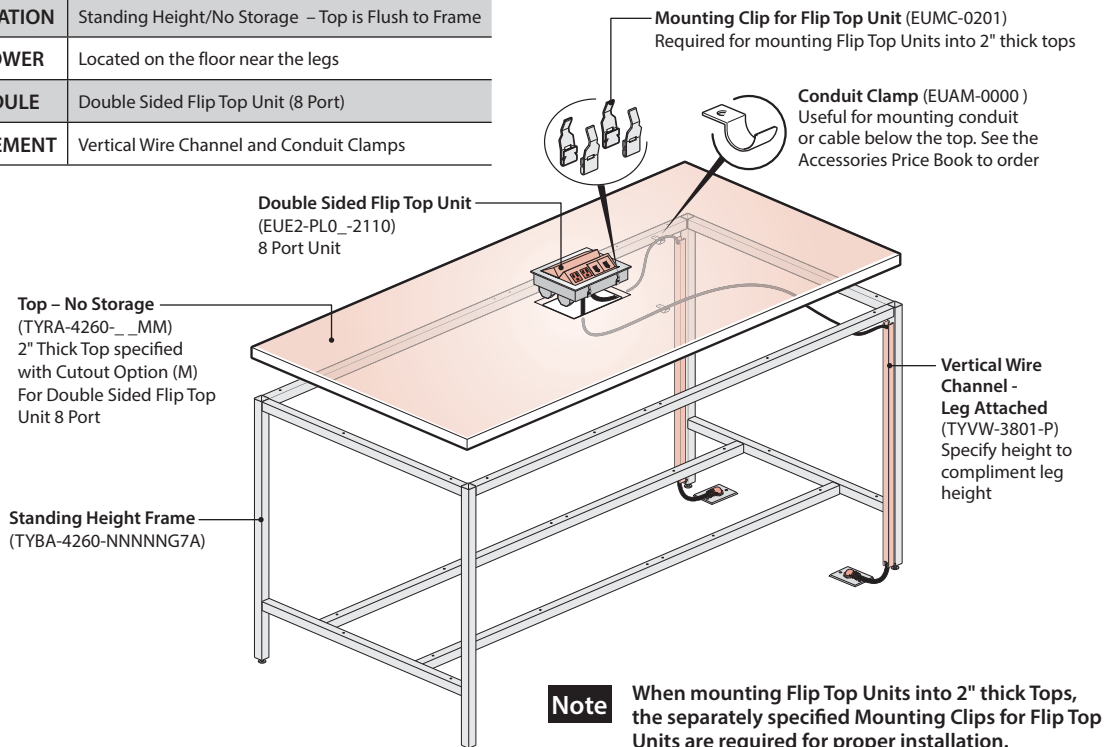

TABLE APPLICATION	Standing Height/No Storage – Top is Flush to Frame
BUILDING POWER	Located on the floor near the legs
POWER MODULE	Double Sided Flip Top Unit (8 Port)
WIRE MANAGEMENT	Vertical Wire Channel and Conduit Clamps



Note When mounting Flip Top Units into 2" thick Tops, the separately specified Mounting Clips for Flip Top Units are required for proper installation.

Product Application – Cultivate Tables

Power/Data and Wire Management Applications

Table Top Power and Data Applications

- Do**
 - Specify Tops with no factory cutout for power modules that require a field installed cutouts.
 - Specify appropriate wire management components to route cords and cables.

TABLE APPLICATION	Seated Height / No Storage with 12" overhangs on each end.
BUILDING POWER	Located on the floor near the legs.
POWER MODULE	Wireless Charging Module
WIRE MANAGEMENT	Vertical Wire Channel and Wire Management Clips

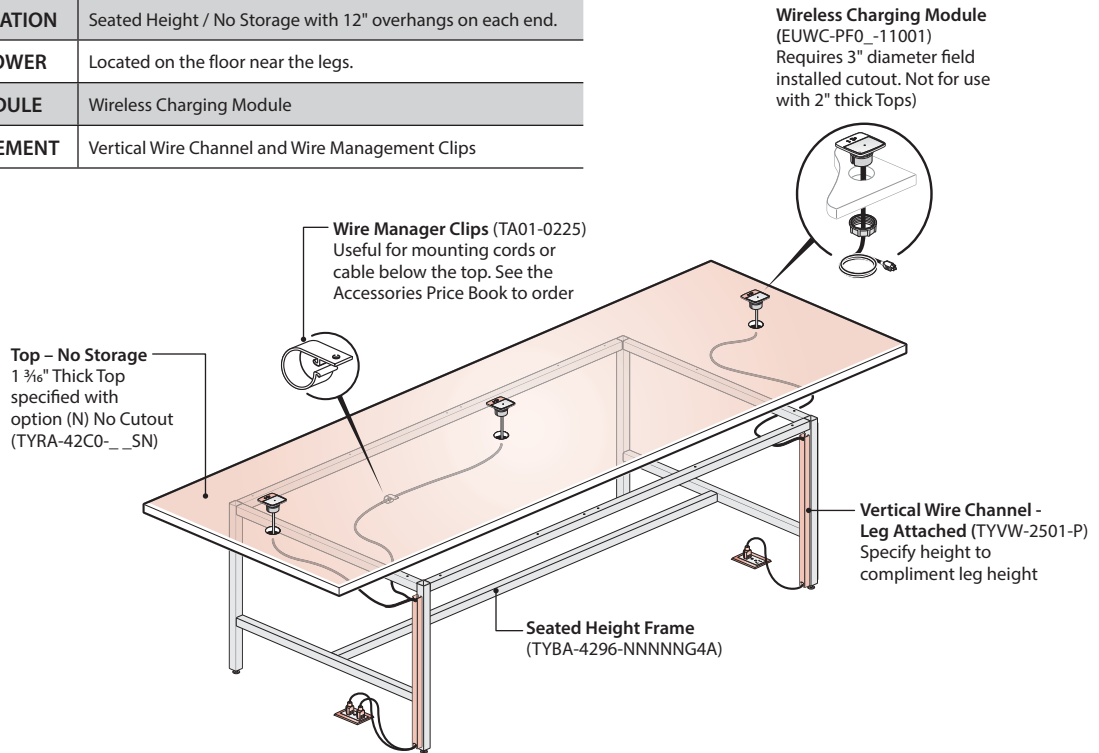

Note • The Wireless Charging Module is designed for installation in tops between 3/4" and 1 3/4" thick, the module cannot be used with 2" thick tops.

Product Application – Cultivate Tables

Power/Data and Wire Management Applications

Below the Top/Perimeter Power and Data Application

- ✓
Do
 - Specify below the top/perimeter power using a Seamless Enhanced Power Module with the Mounting Bracket for Enhanced Power Modules.
 - Specify appropriate wire management components to route cords and cables.

TABLE APPLICATION	Standing Height/Storage on Two Sides
BUILDING POWER	Located on the floor, near legs.
POWER MODULE	Seamless Enhanced Power Module (3 Port)
WIRE MANAGEMENT	Vertical Wire Channel - Leg Attached

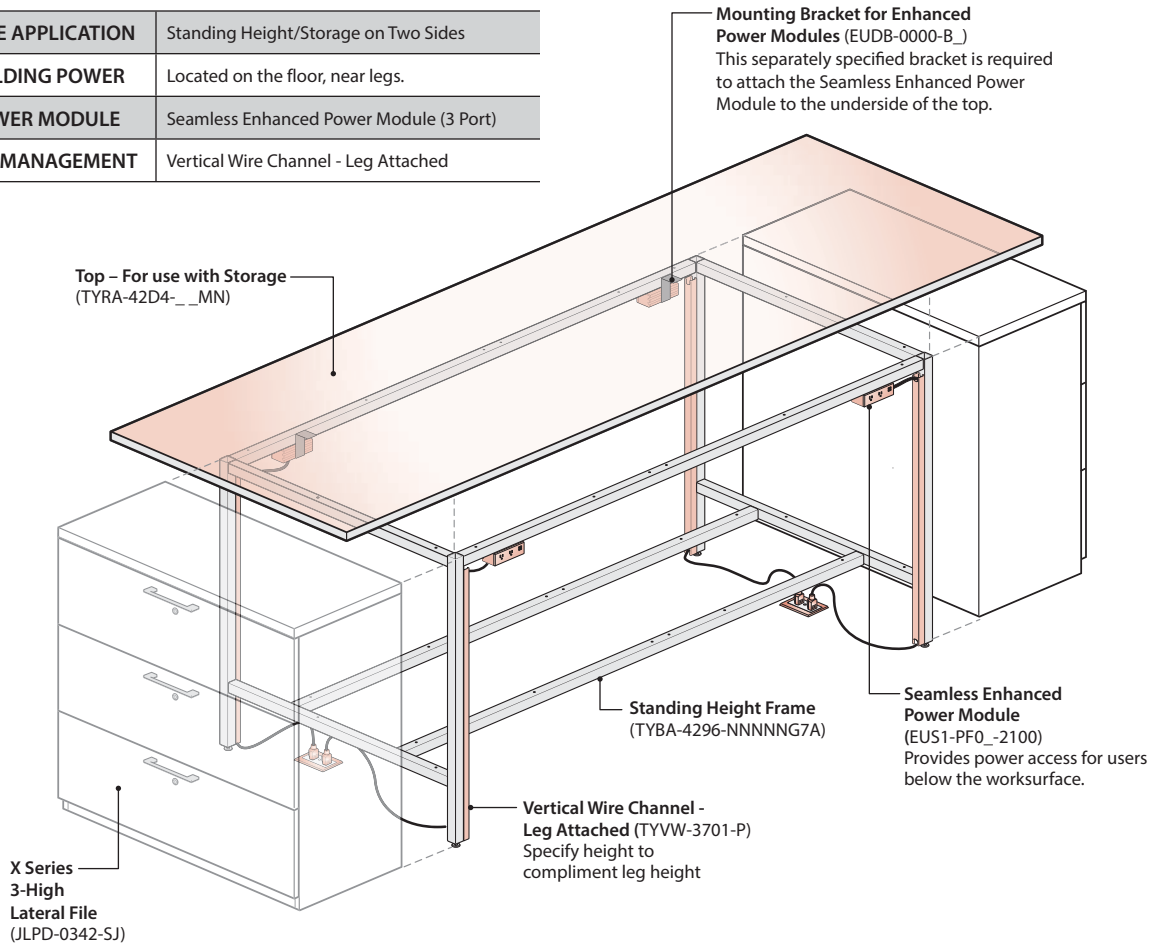

Product Application – Cultivate Tables

Power/Data and Wire Management Applications

workware Monitor Mounting Application



Do

- For monitor mounting capabilities, install workware View on tables tops overhanging the frame.
- The overhang must be a minimum of 8" and cannot exceed the maximum overhang of 18".
- 42" Top depths are recommended with the 41" wide version.
- For Table top power access, specify Tops with appropriate factory cutouts to accept either Flush Mounted Power or the Flip Top Units – Double-sided.
- Specify appropriate wire management components to route cords and cables.

TABLE APPLICATION	Seated Height/No Storage – Top Overhanging Frame
BUILDING POWER	<ul style="list-style-type: none"> • Located on the floor, near the center of the table • Located on the wall at the end of table
POWER MODULE	<ul style="list-style-type: none"> • Flush Mount Power Module (6 Port) • Seamless Enhanced Power Module (4-Port)
WIRE MANAGEMENT	<ul style="list-style-type: none"> • Vertical Cable Chain, Vertical Wire Channel and Wire Manager Clips
MONITOR SUPPORT	<ul style="list-style-type: none"> • workware View Table Mount without Shroud
TECHNOLOGY	<ul style="list-style-type: none"> • workware Wireless Base • Monitor (Field Supplied)

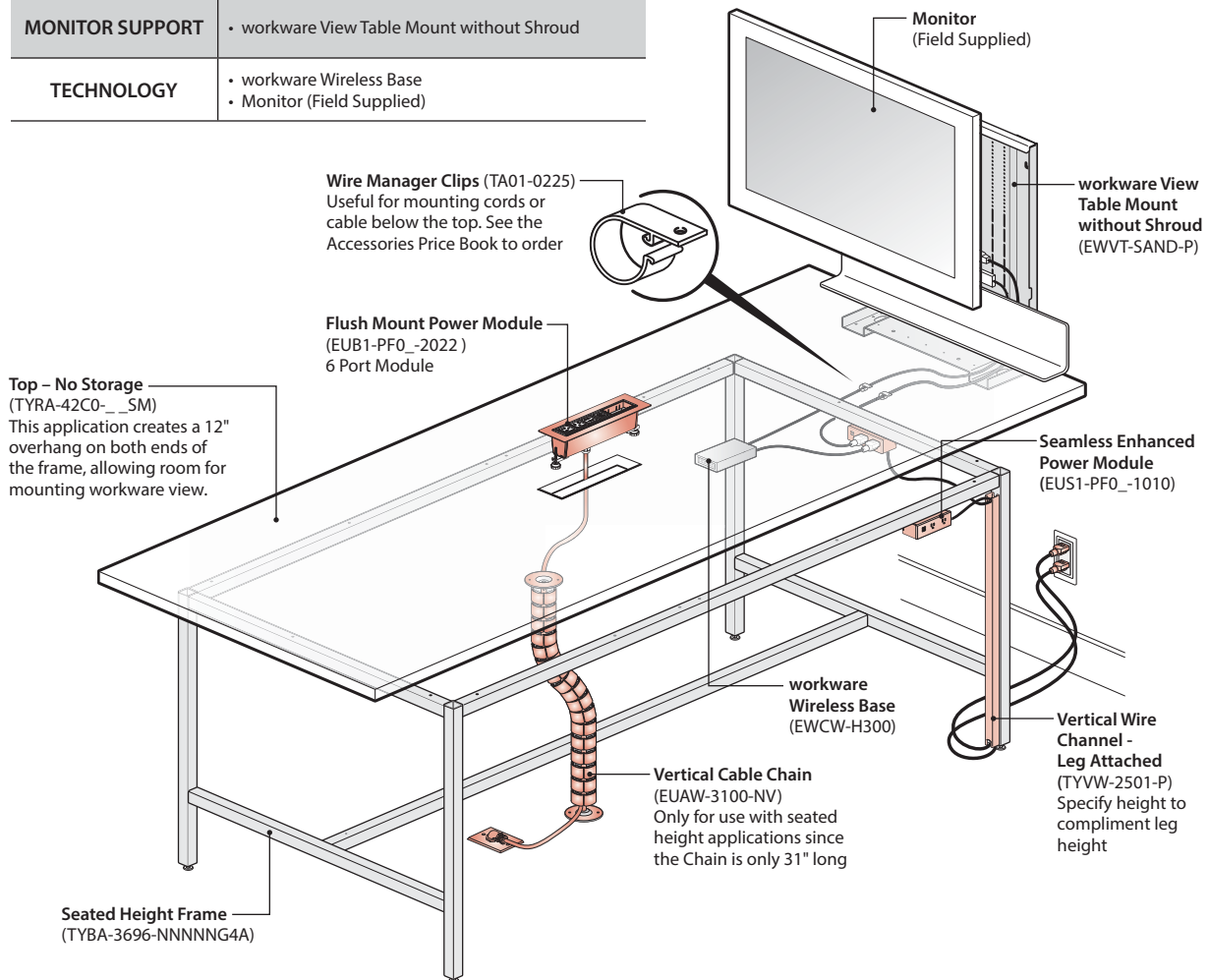

Product Application – Cultivate Tables

Power/Data and Wire Management Applications

Additional Power/Data/Charging Options

To provide a wider array of power, data and charging options, the following power components are recommended for use with Cultivate Tables. Components requiring cutouts will require a field installed cutout or the top could be ordered through tailored solutions with a custom factory cutout.

Table Top Power Access

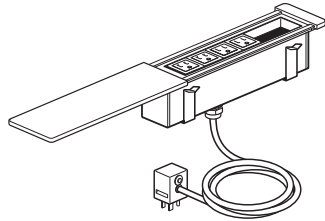

- workware connect Interface Module – Non-Switching**
4-Port or 6-Port Narrow – Corded
(EWCG-3A2E-NPSCBNPW)
- A Separately specified workware Interface Mounting Bracket (EWM-0601-P) is required for installation on 2" thick tops.
 - For details see the workware Price Book.

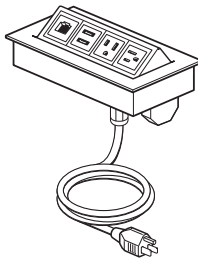

- Flip Top Unit – Single-Sided**
2-Port, 4-Port or 6-Port – Corded
(EUE1-PF0B-2110)
- For details see the Accessories Price Book.

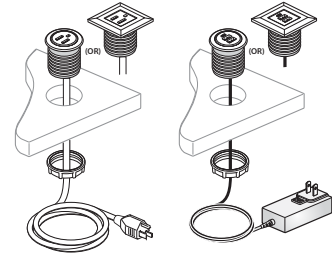

- Bezel Utility Module**
Round or Square Face
Power Outlet or USB Charging
(EURT-0072-1100)
(EURT-0072-1010)
- Not for use with 2" thick tops.
 - For details see the Accessories Price Book.

Below Top Power Access

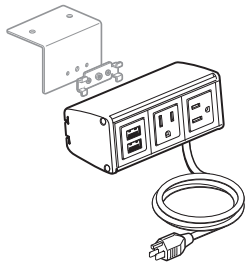

- Enhanced Power Module**
3-Port, 4-Port or 6-Port
Corded or Hardwired
(EUD1-PF0B-2100)
- Requires separately specified Under Worksurface Bracket – Fixed
(EUDB-0000-UB_)
- For details see the Accessories Price Book.

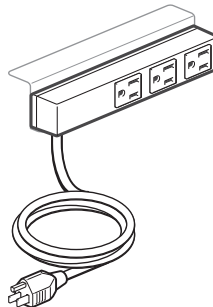

- Power Tap**
Horizontal or Vertical
Corded or Hardwired
(EUT-0000-1M3N1EL)
- Requires separately specified Power Tap Bracket – Under Surface
(ZUAP-0000-PUR)
- Contact Haworth for guidance on power solutions in freestanding furniture.
 - For details see the Accessories Price Book.

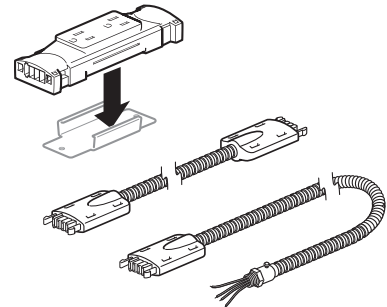

- Planes Training Tables – 2-Circuit Power Receptacles – 15 Amp – 2-Circuit**
(EAER-0015-2_G)
- Tables Pass-Through Connector – 2-Circuit**
(EAEJ-00_ _-2)
- Hardwire Modular Base Feed – 2-Circuit**
(EAEB-20_ _-2H)
- Contact Haworth for guidance on power solutions in freestanding furniture.
 - For details see the Accessories Price Book.

Product Application – Cultivate Tables

Power/Data and Wire Management Applications

Additional Wire Management Options

The following Wire Management components may also be field installed on Cultivate Tables to provide additional Wire Management options.

Below Top Wire Management Options

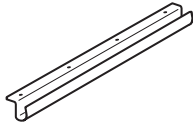

Horizontal Wire Management
(WUAW-1500-PNH)
• For details see the Accessories Price Book.

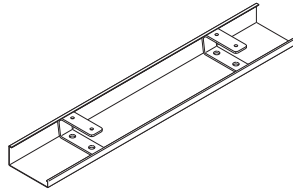

Wire Manager – Horizontal
(EUAW-00_-NH)
• For details see the Accessories Price Book.

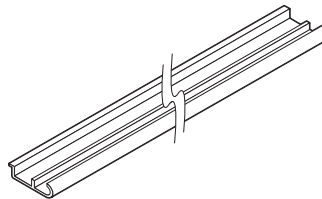

Wire Management Trough
(KWT)
• For details see the Accessories Price Book.

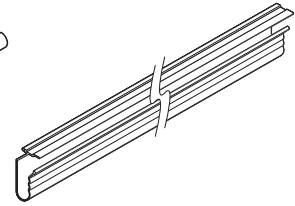

J-Channel
(4TJC-72)
• For details see the Accessories Price Book.

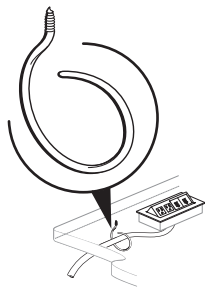

Wire Management Loop
(NEH-8)
• For details see the Accessories Price Book.

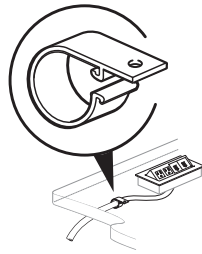

Wire Manager Clips
(TA01-0225)
• For details see the Accessories Price Book.

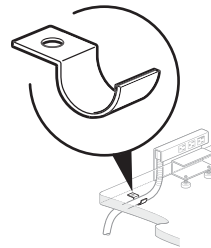

Conduit Clamp
(EUAM-0000)
• For details see the Accessories Price Book.

Product Application – Cultivate Tables

Monitor Mounting and Information Display Applications

Monitor Mounting/Information Display Options

Cultivate Table are designed to work with a variety of components for monitor mounting and information display.

Table Top Monitor Mounting

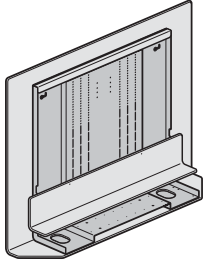

workware View – Table Mount With Shroud – Single Monitor
(EWVT-S_SD-P)

- Table Mount with Shroud requires an 8" overhang and a 42" Top depth is recommended with the 41" wide version.
- For details see the workware Price Book.

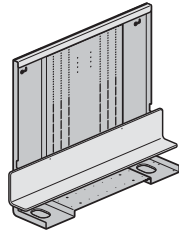

workware View – Table Mount Without Shroud – Single Monitor
(EWVT-S_ND-P)

- The bracket requires 33" of top depth to mount, all sizes of workware View - Table Mount Without a Shroud can mount to 36" or 42" table depths.
- For details see the workware Price Book.

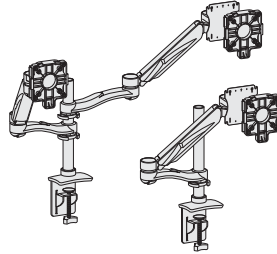

Monitor Arm Adjustable Post Arm
(KU5M-2NNN)
(KU5M-1NNN)

- Located in the Accessories Price Book.

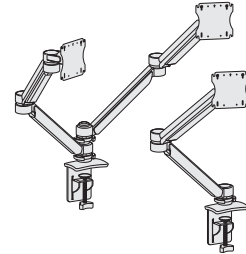

Monitor Arm Extended Arm
(KU6M-2NNN)
(KU6M-1NNN)

- Located in the Accessories Price Book.

Wall and Freestanding Monitor Mounting

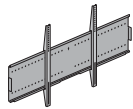

Single Monitor Without Shroud
(EWVD-SNNN-PN)

- For details see the workware Price Book.

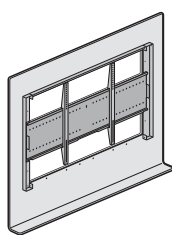

Single Monitor With Shroud – 3 1/8" Deep Radius Edge Shelf
(EWVD-S_SS-PP)

- For details see the workware Price Book.

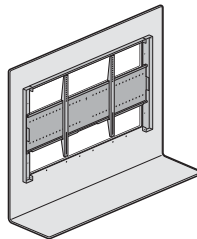

Single Monitor With Shroud – 12" Deep Radius Edge Shelf
(EWVD-S_SD-PP)

- For details see the workware Price Book.

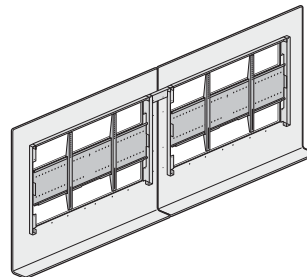

Dual Monitor With Shroud 3 1/8" Deep Radius Edge Shelf
(EWVD-D_SS-PP)

- For details see the workware Price Book.

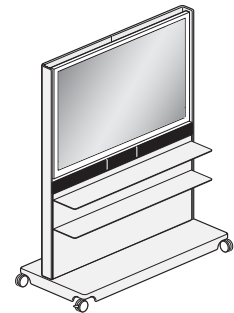

Mobile Monitor Easel For Non-Switching Interface Module – Seated Height
(EWM-SB4P-P)

Shelf Tile for Mobile Monitor Easel
(EWM-SB4P-P2)

- Located in the workware Price Book.

Information Display

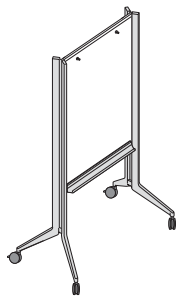

Standard Easel
(KAIE-0029)

- Located in the Accessories Price Book.

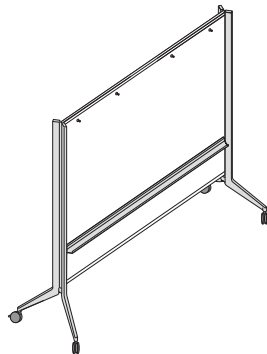

Large Easel
(KAIE-0072)

- Located in the Accessories Price Book.

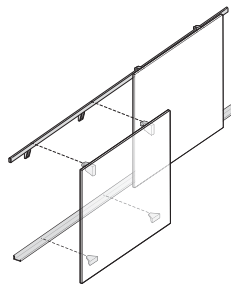

Information Boards
(KAIB-0040)

Horizontal Wall Rail for Information Boards
(KAIW-0096)

- Located in the Accessories Price Book.

Specification Guide – Cultivate Tables Technical Specifications Section

Cultivate Technical Specifications

Frames

Welded End Leg Assemblies are made with 14-gauge (.083", 2.1mm) 1.5" (38.1mm) square steel tubing with powder-coat paint. Support beams and foot rails are 12-gauge (.109", 2.8mm) 1.5" (38.1mm) square, steel tubing with powder-coat paint. Seated height unit includes one footrest rail and standing height unit includes two footrest rails. Support tubes and footrest rails attach to leg assembly with threaded fasteners. Metal glides provide 1.18" (30.2mm) adjustment.

Tops

Tops are available 1.18" (30.2mm) thick made with a solid engineered composite wood panel or 2" thick (50.8mm) made with engineered composite wood frame and skins with Kraft paper honeycomb and frame rails bonded between the skins.

The composite wood materials are made with 100% recycled and/or recovered wood fiber bonded with resin. These materials are 3rd party certified compliant with CARB Phase 2 and EPA TSCA Title VI requirements for formaldehyde emissions. FSC® Certification for composite wood materials are available.

Tops are 3rd party certified compliant by GREENGUARD, SCS Indoor Advantage or Intertek Clean Air, to ANSI/BIFMA X-7.1 Standard for Formaldehyde & TVOC Emissions of Low-Emitting Office Furniture and Seating.

- Laminate Tops are made with high-pressure laminate on the top, a laminate backer on the bottom and a 0.125" (3mm) radius, plastic edge band on the user edges. Tops wider than 120" are two-piece tops with the mating edge capped with 0.039" (1mm) thick plastic edge band for the 1.18" thick tops and 0.125" (3mm) radius for the 2" thick tops.
- Wood Veneer Tops are made with wood veneer on the top, a balancing backer on the bottom and a 0.125" (3mm) radius wood edge band on the user edges. Tops wider than 120" are two-piece tops with the mating edge capped with 0.028" (.7mm) thick wood edge band for the 1.18" thick tops and 0.125" (3mm) radius for the 2" thick tops.

Immerse Tables Specification Guide

Product Details Section

Product Details – Immerse Tables

Product Introduction

The Power of Spontaneous Collaboration

Human beings are social creatures. We crave interaction and thrive in moments of spontaneity. Immerse tables were thoughtfully designed out of a design partnership between Haworth and Patricia Urquiola to help us connect, collaborate, and engage. They create a landscape of varied surfaces, providing a welcoming community hub that transforms collaborative experiences, warms up the work environment, and promotes well-being.

Catalyst for Collaboration

Creativity and innovation can take shape at a moment's notice with Immerse. A catalyst for spontaneous collaboration, each table creates a social hub that invites serendipity, variety, and choice in the workplace.

Happily Engaged

Culture can't be forced or manufactured. But it can be nurtured. Immerse captures the feeling of home in the workplace. Warm and welcoming, the tables' comfortable, people-centric design keeps everyone inspired and engaged.

Positive Energy

It's proven. Healthy humans create positive energy that delivers better performance in the workplace. Immerse focuses on our natural movements, creating a landscape for you to sit, stand, and support your overall well-being.



Product Details – Immerse Tables

Product Introduction – The Immerse Family of Tables

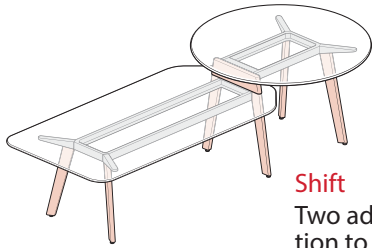

Shift

Two adjacent worktops, each at varied heights, supports natural inclination to work together. Considered the workhorse of the workplace.

Rectangle/Rectangle – 60" x 156" (Lower: 60" x 86" / Upper: 48" x 96")

Racetrack/Round – 48" x 138" (Lower: 48" x 96" / Upper: 60" x 60")

Rectangle/Round – 48" x 138" (Lower: 48" x 96" / Upper: 60" x 60")

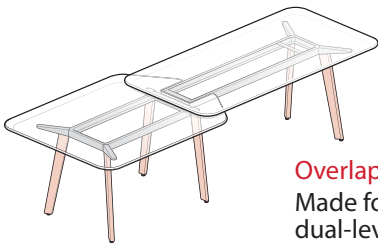

Overlap

Made for movement, sitting or standing, Overlap features a unique dual-level workspace designed to stimulate overall well-being.

Rectangle/Round – 48" x 138" (Lower: 48" x 96" / Upper: 60" x 60")

Rectangle/Ledge – 48" x 124" (Lower: 48" x 120" / Upper: 22" x 57")

Rectangle/Rectangle – 60" x 156" (Lower: 60" x 78" / Upper: 48" x 96")

Racetrack/Round – 48" x 138" (Lower: 48" x 96" / Upper: 60" x 60")

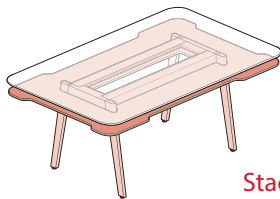

Stack

Stack's double-layer, lower sill gives you the space, storage and flexibility to do your best work, on your own terms.

Rectangle – 60" x 96", 60" x 120", 60" x 144"

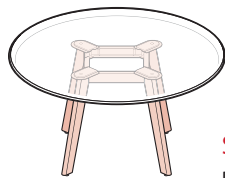

Single

Round – 48", 60"

Square – 48", 60"

Rectangle – 48" x 96", 48" x 144", 60" x 120", 60" x 144"

Racetrack – 48" x 96"



Ledge

Great for impromptu conversations, or a place to buckle down and get busy.

Rectangle – 22" x 57"

Product Details – Immerse Tables

Table Top Construction and Edge Details

(W) Wood Top Surface Options

- Standard core with a specified wood veneer top finish and matching edgeband finish/color.
- Edge Detail: Knife Edge is standard on all sides/edges of top.

(L) Laminate Top Surface Options

- Standard core with a specified laminate top finish and a separate specification for edgeband finish/color.
- Edge Detail: Knife Edge is standard on all sides/edges of top.

(P) Painted Top Surface Option

- MDF core with painted top and edge.
- Edge Detail: Knife Edge on all sides/edges of top

(S) Solid Surface Top Surface Options

- Built up solid surface edge (4" deep around table perimeter) with a 1/2" wood core.
- Solid Surface color is standard in Cameo White.
- Edge Detail: Knife Edge on all sides/edges of top

Edge Detail for Single, Shift and Overlap Table Tops

(W) Wood Top Option

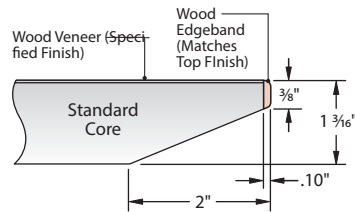

(L) Laminate Top Option

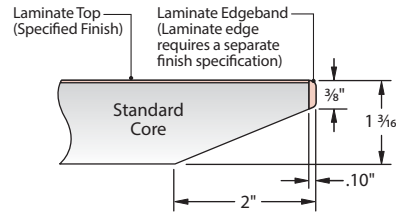

(P) Painted Top Option

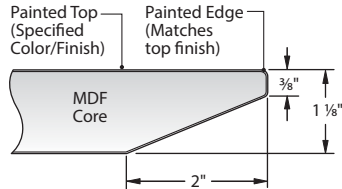

(S) Solid Surface Top Option

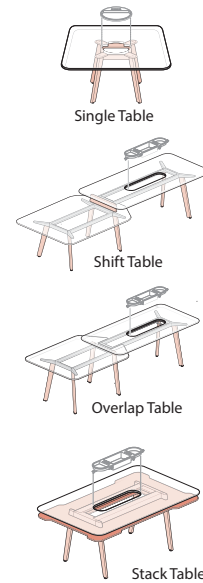
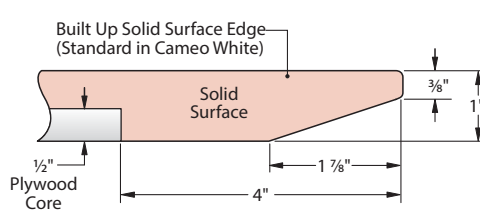

Edge Detail for Stack Tables

(W) Wood Top / Solid Surface Sill

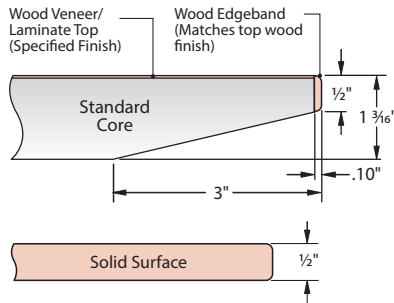

(L) Laminate Top / Laminate Sill

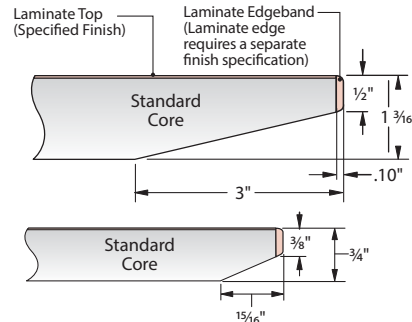

(S) Solid Surface Top / Solid Surface Sill

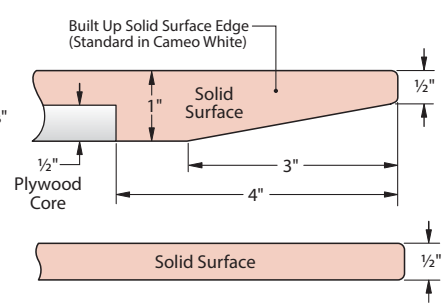

Note The Painted Surface Option (P) is not available with the Stack Table.

Edge Detail for Ledge Top

Wood or Laminate Top Option

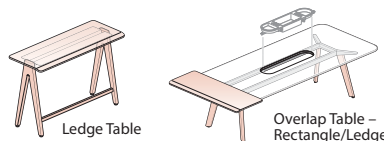
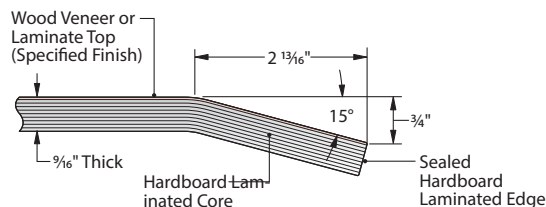

Product Details – Immerse Tables

Table Heights

- Immerse Tables are designed with variety of available heights, to accommodate both sitting and standing work styles.

29" Table Tops

- For use with standard seated height applications.
- Specify with standard seated height chairs.



The 29" high table top is for use with most standard seated height chairs.

36" High Table Tops

- For use with seated or standing applications.
- Specify with counter height stools.

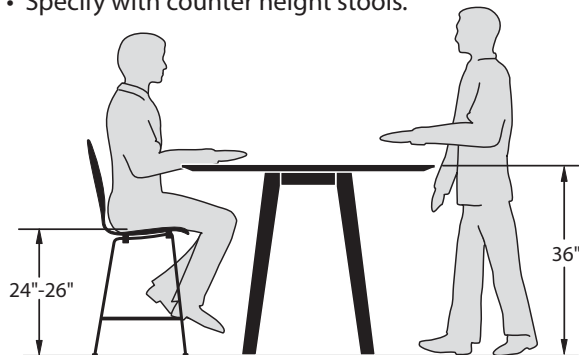

The 36" high table top is for use with most counter height stools or standing applications.

39" High Table Tops

- For use with seated or standing applications.
- Specify with bar height stools.

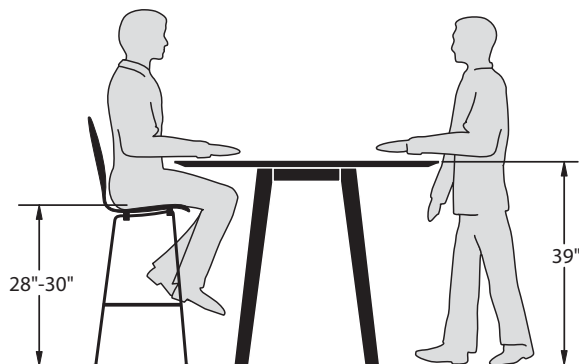

The 39" high table top is for use with most bar height stools or standing applications.

Note The Immerse Overlap Tables includes an upper top that may be specified 30 ½" high or 37 ½" high.
 – 30 ½" high table tops should be specified with standard seating height chairs.
 – 37 ½" high table tops may be specified with counter height or bar height stools.
 Ensure seating is specified to provide proper user alignment with the top while providing adequate clearance below the top for user legs, see product details section for table dimensions.

Product Details – Immerse Tables

Single Table

Round (One Piece Top)

- Includes round top, (4) legs with adjustable glides, understructure and hardware.
- For added storage and power access, 60" diameter tables may be specified with cutout option (P) and a separately specified Round Planter (not available with 48" diameter round tables).

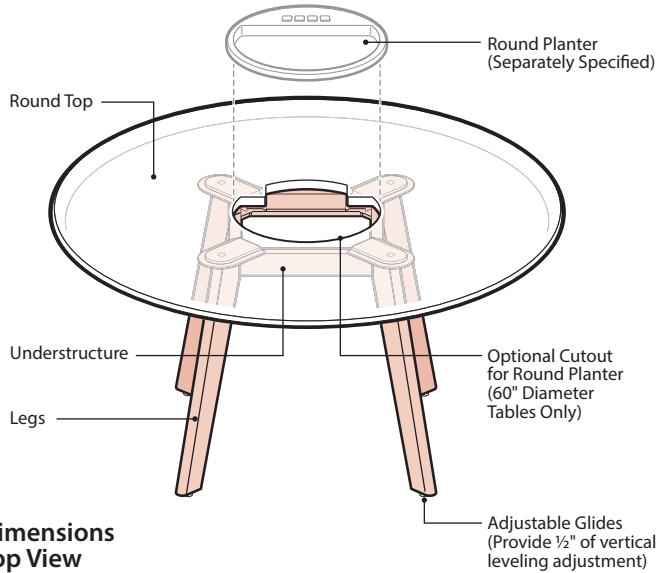

Dimensions Top View

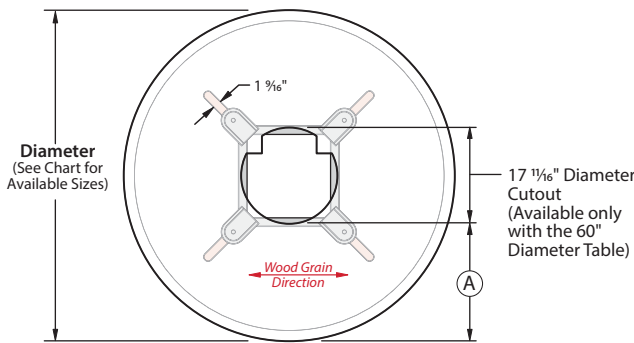

Front View

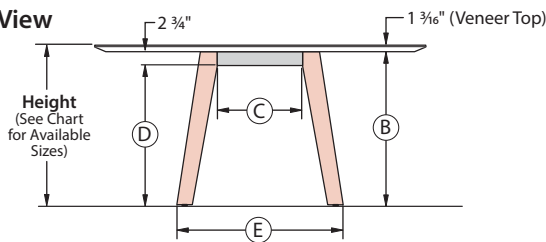

Dimensions by Table Size

Heights Nominal (Actual) (Veneer Top With glides fully recessed)	Diameter Nominal (Actual)	Top Dimensions		Kneespace Dimensions		
		A	B	C	D	E
29" (29.43")	48" (48.00")	N/A*	28 1/4"	10 5/16"	25 1/2"	25 5/16"
	60" (60.00")	21 3/16"	28 1/4"	15 9/16"	25 1/2"	25 5/16"
36" (36.18")	48" (48.00")	N/A*	35"	12 1/16"	32 1/4"	27 1/4"
	60" (60.00")	21 3/16"	35"	16 1/16"	32 1/4"	31 1/4"
39" (39.18")	48" (48.00")	N/A*	38"	12 1/16"	35 1/4"	27 7/16"
	60" (60.00")	21 3/16"	38"	16 1/16"	35 1/4"	31 7/16"

*48" Diameter Tables are not available with cutout option.

Component Materials and Finishes

COMPONENT NAME	MATERIALS/FINISHES	
Round Top (Standard with Knife Edge)	(L) Laminate	Standard Core - Specify surface color and a separate edge finish color
	(P) Painted	MDF Core with Specified Paint finish.
	(S) Solid Surface	Wood core/built up Solid Surface edge, Standard in Cameo White.
Legs	(W) Wood	Standard Core - Specify a single color for the surface and edge finishes.
	Solid Wood	Ink on Ash (M7-W43) Clear on White Oak (M5-W35) Clear on Walnut (M6-W35)
	Painted	Painted metal - specified trim color
Understructure	Painted Metal with specified trim color	
Adjustable Glides	Standard in Black	

Table Heights

- Available in three heights for seated or standing applications.



Seating Capacity

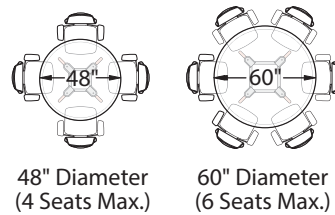

Optional Cutout for Round Planter

- For added storage and power 60" diameter tables may be specified with cutout option (P) to accommodate a separately specified Round Planter.
- The Round Planter may be specified with or without power.

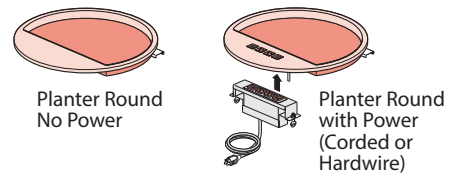

Product Details – Immerse Tables

Single Table

Square (One Piece Top)

- Includes square top, (4) legs, adjustable glides, understructure and hardware.
- For added storage and power access, 60" square tables may be specified with cutout option (P) and a separately specified Round Planter (not available with 48" deep square tables).

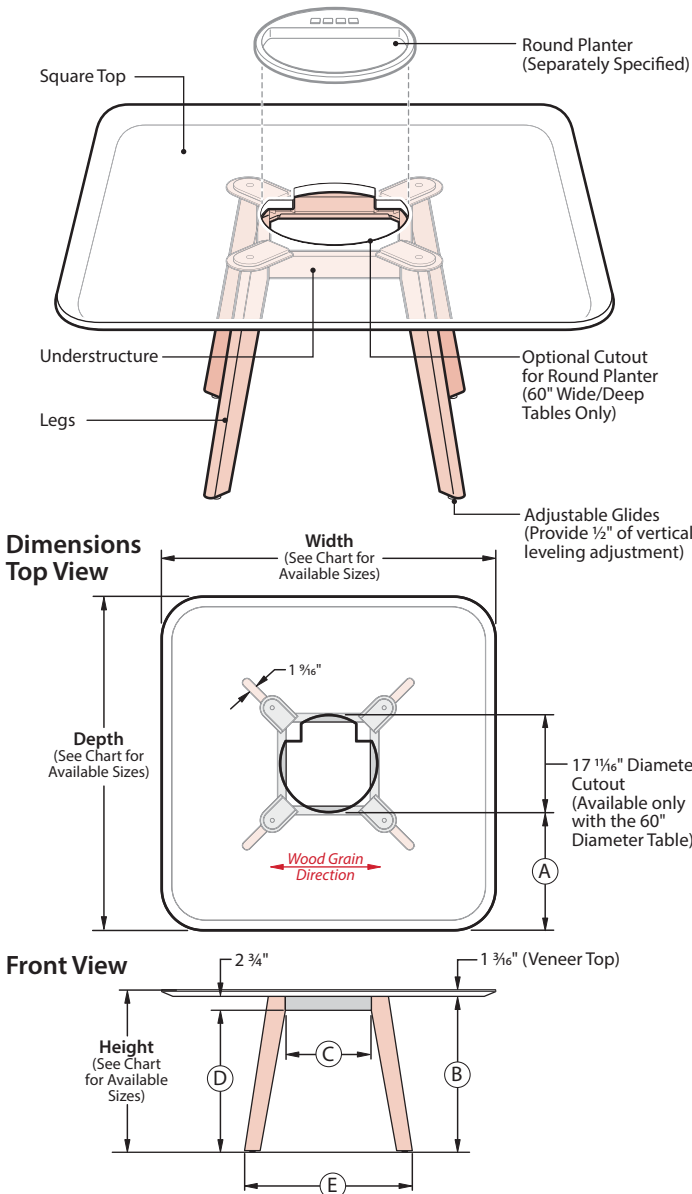

Dimensions by Table Size

Heights Nominal (Actual) (Veneer Top With glides fully recessed)	Diameter Nominal (Actual)	Top Dimensions				
		A	B	C	D	E
29" (29.43")	48" (48.00")	N/A*	28 1/4"	14"	25 1/2"	29"
	60" (60.00")	21 3/16"	28 1/4"	19 1/2"	25 1/2"	34 1/2"
36" (36.18")	48" (48.00")	N/A*	35"	15 13/16"	32 1/4"	30 3/8"
	60" (60.00")	21 3/16"	35"	20 1/16"	32 1/4"	35 1/4"
39" (39.18")	48" (48.00")	N/A*	38"	15 13/16"	35 1/4"	31 1/16"
	60" (60.00")	21 3/16"	38"	20 1/16"	35 1/4"	34 15/16"

*48" Wide/Deep Tables are not available with cutout option.

Component Materials and Finishes

COMPONENT NAME	MATERIALS/FINISHES	
Square Top (Standard with Knife Edge)	(L) Laminate	Standard Core - Specify surface color and a separate edge finish color
	(P) Painted	MDF Core with Specified Paint finish.
	(S) Solid Surface	Wood core/built up Solid Surface edge, Standard in Cameo White.
	(W) Wood	Standard Core - Specify a single color for the surface and edge finishes.
Legs	Solid Wood	Ink on Ash (M7-W43) Clear on White Oak (M5-W35) Clear on Walnut (M6-W35)
	Painted	Painted metal - specified trim color
Understructure	Painted Metal - specified trim color	
Adjustable Glides	Standard in Black	

Table Heights

- Available in three heights for seated or standing applications.

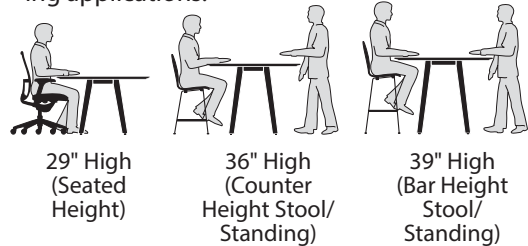

Seating Capacity

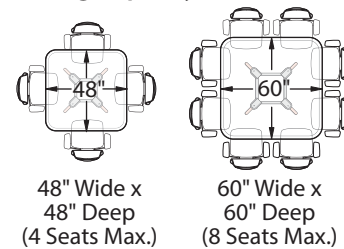

Optional Cutout for Round Planter

- For added storage and power 60" wide/deep tables may be specified with cutout option (P) to accommodate a separately specified Round Planter.
- The Round Planter may be specified with or without power.

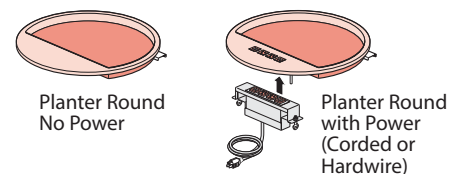

Product Details – Immerse Tables

Single Table

Rectangle (One-Piece Top)

- Includes a rectangle top, (4) legs, understructure, adjustable glides, and hardware.
- For storage and/or power access, specify option (P) for Cutout. Cutout works with separately specified Oblong Planter.

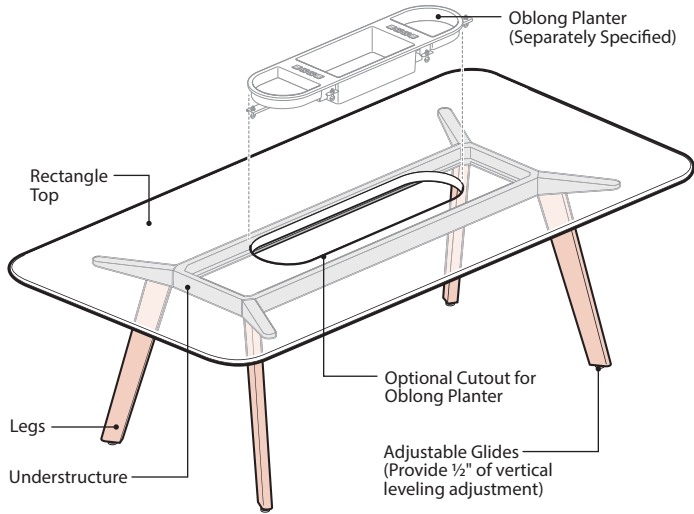

Component Materials and Finishes

COMPONENT NAME	MATERIALS/FINISHES	
Rectangle Top (1-Piece, Standard with Knife Edge)	(L) Laminate	Standard Core - Specify surface color and a separate edge finish color
	(P) Painted	MDF Core with Specified Paint finish.
	(S) Solid Surface	Wood core/built up Solid Surface edge, Standard in Cameo White.
	(W) Wood	Standard Core - Specify a single color for the surface and edge finishes.
Legs	Solid Wood	Ink on Ash (M7-W43) Clear on White Oak (M5-W35) Clear on Walnut (M6-W35)
	Painted	Painted metal – specified trim color
Understructure	Painted Metal – specified trim color	
Adjustable Glides	Standard in Black	

Table Heights

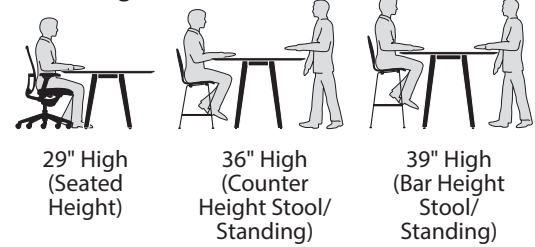

Dimensions Top View

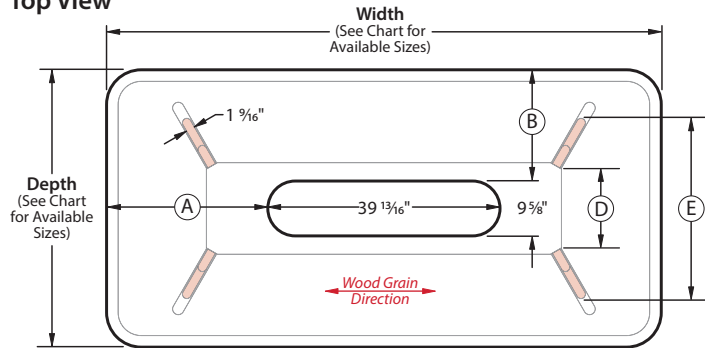

Seating Capacity

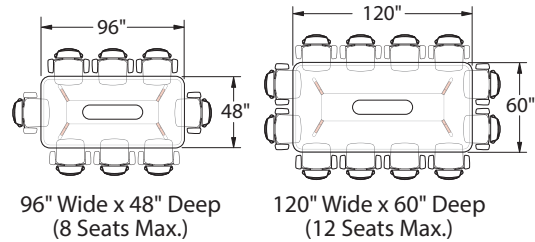

Front View

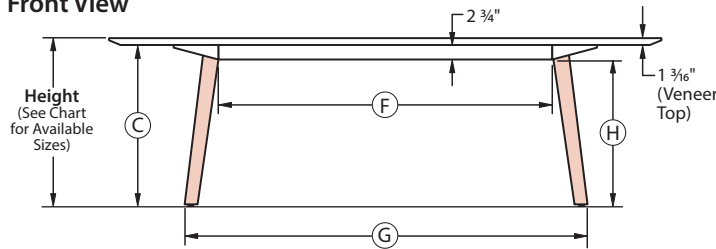

Optional Cutout for Oblong Planter

- For added storage and power specify cutout option (P) to accommodate a separately specified Oblong Planter.
- The Oblong Planter may be specified with or without power.

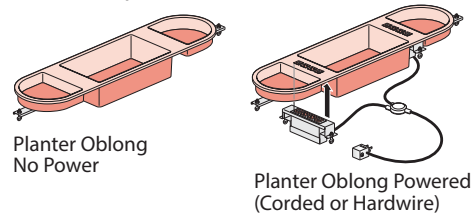

Dimensions by Table Size

Heights Nominal (Actual) (Veneer Top With glides fully recessed)	Depths Nominal (Actual)	Widths Nominal (Actual)	Top Dimensions			Kneespace Dimensions				
			A	B	C	D	E	F	G	H
29" (29.43")	48" (48.00")	96" (96.00")	28 1/8"	19 3/16"	28 1/4"	13 1/16"	31 7/8"	57 3/4"	70 1/16"	25 1/2"
	60" (60.00")	120" (120.00")	40 1/8"	25 3/16"	28 1/4"	16 3/8"	34 3/16"	78 1/2"	90 7/8"	25 1/2"
36" (36.18")	48" (48.00")	96" (96.00")	28 1/8"	19 3/16"	35"	13 1/16"	31 3/16"	57 3/4"	69 3/4"	32 1/4"
	60" (60.00")	120" (120.00")	40 1/8"	25 3/16"	35"	16 3/8"	33 7/8"	78 1/2"	90 7/16"	32 1/4"
39" (39.18")	48" (48.00")	96" (96.00")	28 1/8"	19 3/16"	38"	13 1/16"	32 3/16"	57 3/4"	70 5/16"	35 1/4"
	60" (60.00")	120" (120.00")	40 1/8"	25 3/16"	38"	16 3/8"	34 7/8"	78 1/2"	91 1/16"	35 1/4"

Product Details – Immerse Tables

Single Table

Rectangle (Two-Piece Top)

- Includes a 2-piece rectangle top, (6) legs with adjustable glides, understructure and hardware.
- For storage and/or power access, specify option (P) for Cutout. Cutouts works with (2) separately specified Oblong Planters.

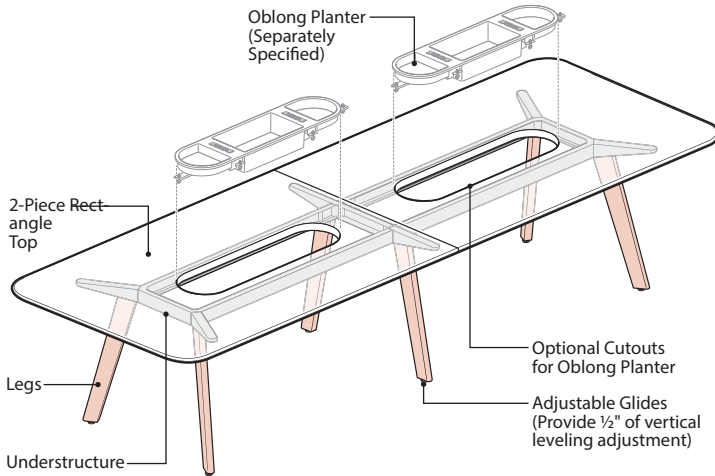

Component Materials and Finishes

COMPONENT NAME	MATERIALS/FINISHES	
Rectangle Top (2-Piece, Standard with Knife Edge)	(L) Laminate	Standard Core - Specify surface color and a separate edge finish color
	(P) Painted	MDF Core with Specified Paint finish.
	(S) Solid Surface	Wood core/built up Solid Surface edge, Standard in Cameo White.
	(W) Wood	Standard Core - Specify a single color for the surface and edge finishes.
Legs	Solid Wood	Ink on Ash (M7-W43) Clear on White Oak (M5-W35) Clear on Walnut (M6-W35)
	Painted	Painted metal – specified trim color
Understructure	Painted Metal – specified trim color	
Adjustable Glides	Standard in Black	

Table Heights



29" High (Seated Height)

Dimensions Top View

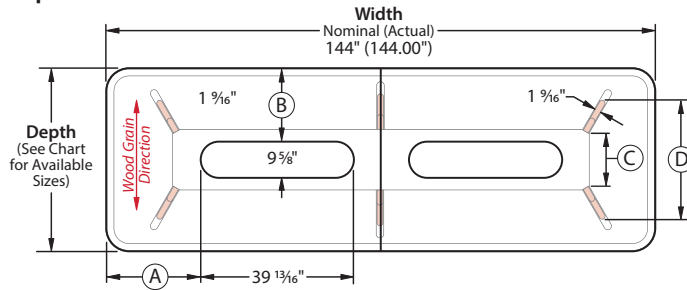

Front View

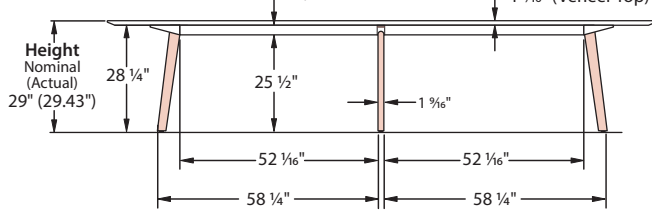

Seating Capacity

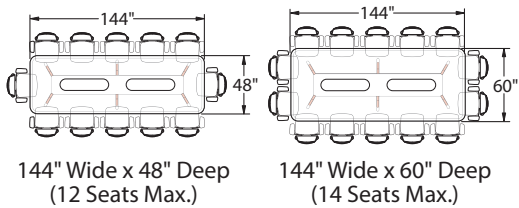

Optional Cutout for Oblong Planter

- For added storage and power specify cutout option (P) to accommodate a separately specified Oblong Planter.
- The Oblong Planter may be specified with or without power.

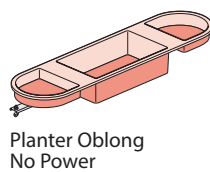

Planter Oblong No Power

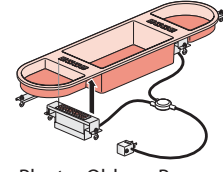

Planter Oblong Powered (Corded or Hardwire)

Dimensions by Table Depth

Heights Nominal (Actual) (Veneer Top With glides fully recessed)	Depths Nominal (Actual)	Widths Nominal (Actual)	Top Dimensions		Kneespace Dimensions	
			A	B	C	D
29" (29.43")	48" (48.00")	144" (144")	24 15/16"	19 3/16"	13 11/16"	31 7/8"
	60" (60.00")	144" (144")	24 15/16"	25 3/16"	16 3/8"	34 9/16"

Product Details – Immerse Tables

Single Table

Racetrack (One Piece Top)

- Includes a racetrack shaped top, (4) legs, understructure, adjustable glides, and hardware.
- For storage and/or power access, specify option (P) for Cutout. Cutout works with separately specified Oblong Planter.

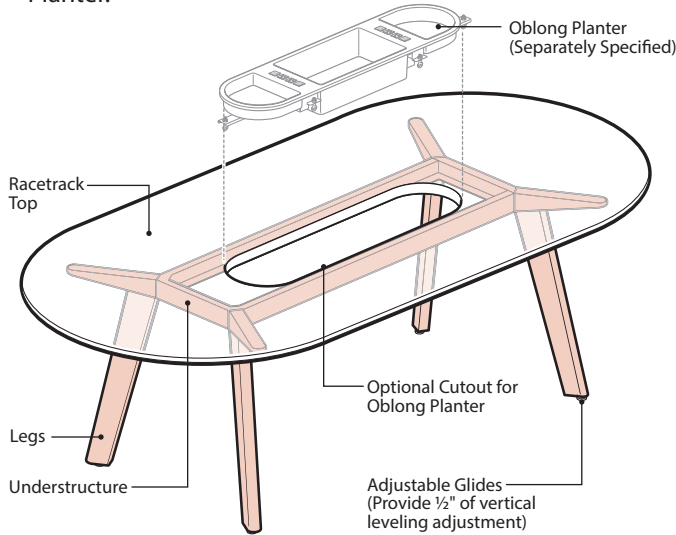

Dimensions Top View

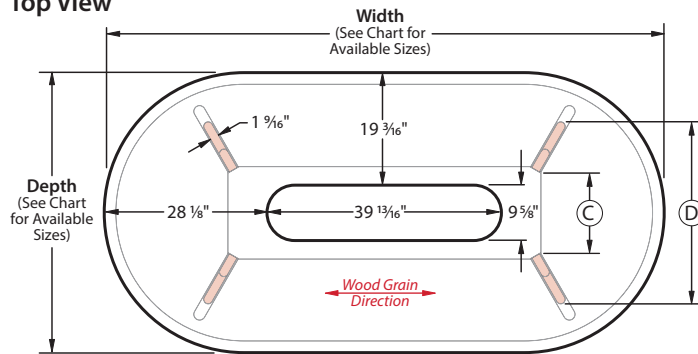

Front View

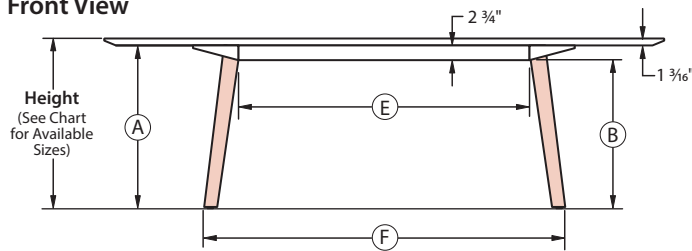

Dimensions by Table Size

Heights Nominal (Actual) (Veneer Top With glides fully recessed)	Depths Nominal (Actual)	Widths Nominal (Actual)	Kneespace Dimensions					
			A	B	C	D	E	F
29" (29.43")	48" (48.00")	96" (96.00")	28 1/4"	25 1/2"	13 11/16"	31 7/8"	49 15/16"	62 3/16"
36" (36.18")	48" (48.00")	96" (96.00")	35"	32 1/4"	13 11/16"	31 3/16"	49 15/16"	61 15/16"
39" (39.18")	48" (48.00")	96" (96.00")	38"	35 1/4"	13 11/16"	32 3/16"	49 15/16"	62 1/2"

Component Materials and Finishes

COMPONENT NAME	MATERIALS/FINISHES	
Racetrack Top (Standard with Knife Edge)	(L) Laminate	Standard Core - Specify surface color and a separate edge finish color
	(P) Painted	MDF Core with Specified Paint finish.
	(S) Solid Surface	Wood core/built up Solid Surface edge, Standard in Cameo White.
Legs	(W) Wood	Standard Core - Specify a single color for the surface and edge finishes.
	Solid Wood	Ink on Ash (M7-W43) Clear on White Oak (M5-W35) Clear on Walnut (M6-W35)
Understructure	Painted	Painted metal - specified trim color
Adjustable Glides	Painted Metal - specified trim color	
Adjustable Glides	Standard in Black	

Table Heights

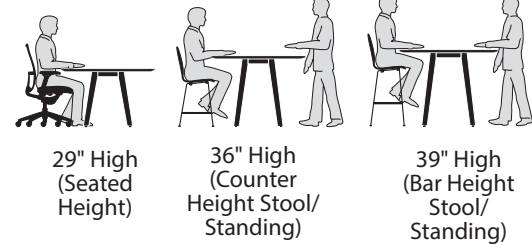

Seating Capacity

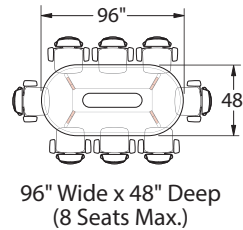

Optional Cutout for Oblong Planter

- For added storage and power specify option (P) to accommodate a separately specified Oblong Planter.
- The Oblong Planter may be specified with or without power.

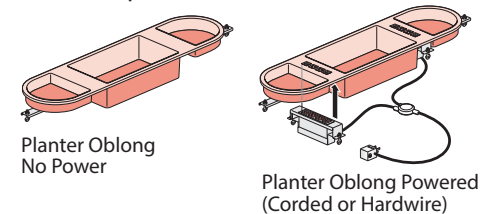

Product Details – Immerse Tables

Stack Table

Rectangle (One-Piece Tops – Upper Top and Sill)

- Includes a 1-piece upper top and sill below, (4) legs, under-structure, adjustable glides, and hardware.
- For storage and/or power access, specify option (P) for Cutout. Cutout works with separately specified Oblong Planter.

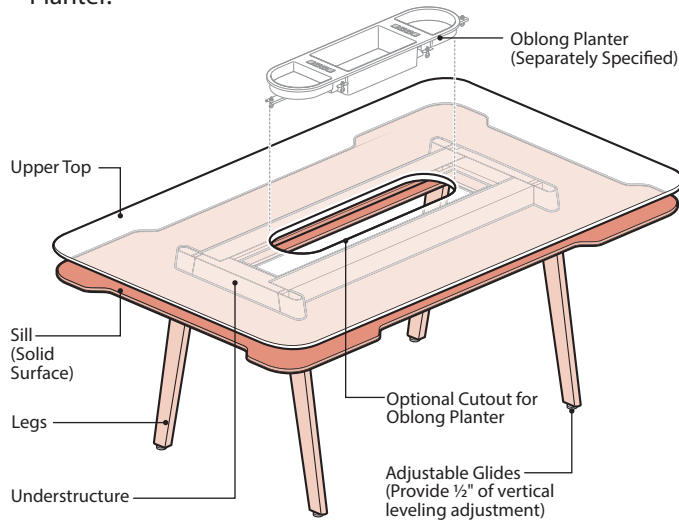

Dimensions Top View

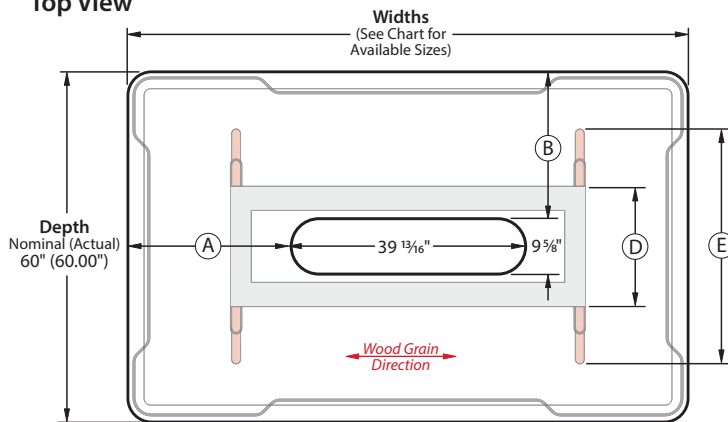

Front View

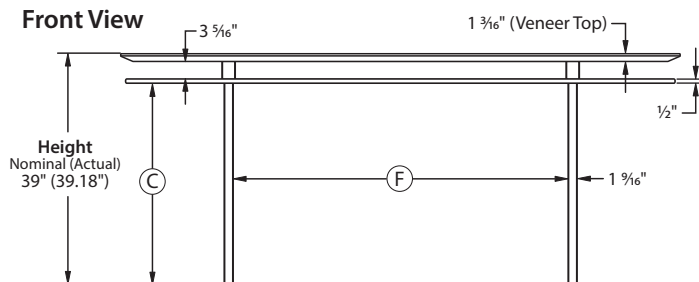

Dimensions by Table Size

Heights Nominal (Actual) (Veneer Top With glides fully recessed)	Depth Nominal (Actual)	Widths Nominal (Actual)	Top Dimensions			Kneespace Dimensions		
			A	B	C	D	E	F
39" (39.18")	60" (60.00")	96" (96.00")	28 1/8"	25 3/16"	34 3/16"	21 1/8"	40 7/16"	57 7/16"
		120" (120.00")	40 1/8"	25 3/16"	34 3/16"	21 1/8"	40 7/16"	81 7/16"

Component Materials and Finishes

COMPONENT NAME	MATERIALS/FINISHES	
Upper Top and Sill	(L) Laminate Surface Option	Upper Top – Laminate Finish with Knife Edge. Specify surface color and a separate edge finish color. Sill – Laminate Finish with Knife Edge. Defaults to same finish as Upper Top.
	(S) Solid Surface Surface Option	Upper Top – Solid Surface with knife edge. Standard in Cameo White. Sill – Solid Surface with square edge. Standard in Cameo White.
	(W) Wood Surface Option	Upper Top – Wood Veneer Finish with Knife Edge. Specify a single wood finish/color for the surface and edge. Sill – Solid Surface with square edge. Standard in Cameo White.
Legs	Solid Wood	Ink on Ash (M7-W43) Clear on White Oak (M5-W35) Clear on Walnut (M6-W35)
	Painted	Painted metal – specified trim color
Understructure	Painted Metal with specified trim color	
Adjustable Glides	Standard in Black	

Table Heights



39" High
(Counter Height Stool/
Standing)

Seating Capacity

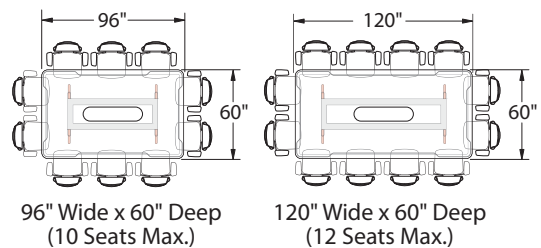

Optional Cutout for Oblong Planter

- For added storage and power specify cutout option (P) to accommodate a separately specified Oblong Planter.
- The Oblong Planter may be specified with or without power.

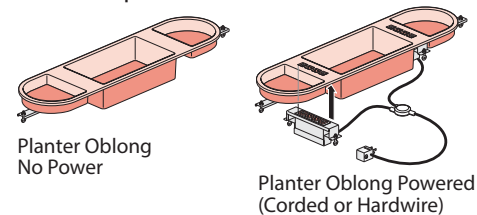

Product Details – Immerse Tables

Stack Table

Rectangle (Two-Piece Tops)

- Includes a 2-piece top above a 2-piece sill, (6) legs, under-structure, adjustable glides, and hardware.
- For storage and/or power access, specify option (P) for Cutout. Cutout works with separately specified Oblong Planter.

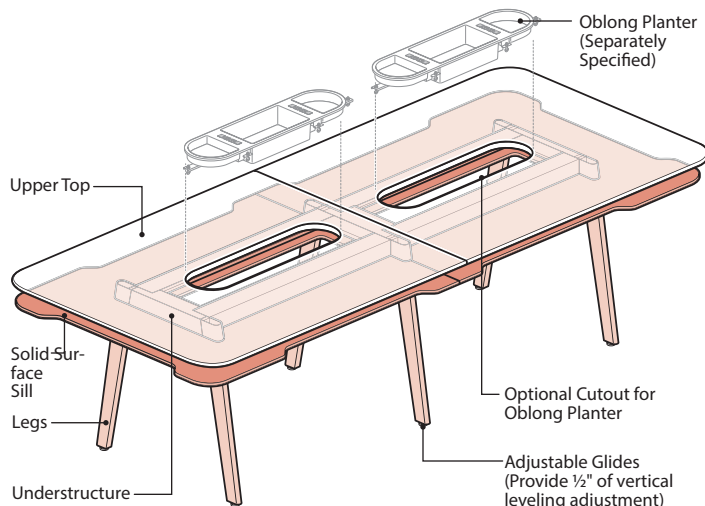

Dimensions Top View

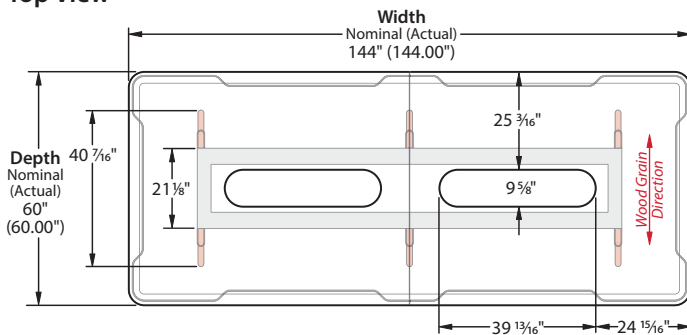

Front View

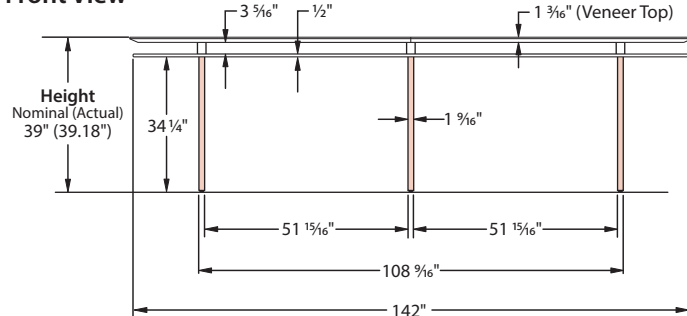

Component Materials and Finishes

COMPONENT NAME	MATERIALS/FINISHES	
Upper Top and Sill	(L) Laminate Surface Option	Upper Top – Laminate Finish with Knife Edge. Specify surface color and a separate edge finish color. Sill – Laminate Finish with Knife Edge. Defaults to same finish as Upper Top.
	(S) Solid Surface Surface Option	Upper Top – Solid Surface with knife edge. Standard in Cameo White. Sill – Solid Surface with square edge. Standard in Cameo White.
	(W) Wood Surface Option	Upper Top – Wood Veneer Finish with Knife Edge. Specify a single wood finish/color for the surface and edge. Sill – Solid Surface with square edge. Standard in Cameo White.
Legs	Solid Wood	Ink on Ash (M7-W43) Clear on White Oak (M5-W35) Clear on Walnut (M6-W35)
	Painted	Painted metal – specified trim color
Understructure	Painted Metal with specified trim color	
Adjustable Glides	Standard in Black	

Table Heights



39" High
(Counter Height Stool/
Standing)

Seating Capacity

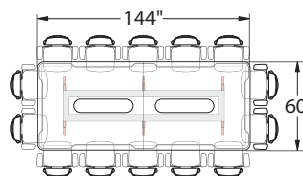

144" Wide x 60" Deep
(14 Seats Max.)

Optional Cutout for Oblong Planter

- For added storage and power specify cutout option (P) to accommodate a separately specified Oblong Planter.
- The Oblong Planter may be specified with or without power.

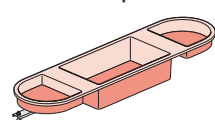

Planter Oblong
No Power

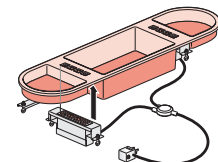

Planter Oblong Powered
(Corded or Hardware)

Product Details – Immerse Tables

Shift Table

Rectangle / Rectangle

- Includes an upper top, lower top, (6) legs, understructure, adjustable glides, stack spacer and hardware.
- For storage and/or power access, the upper top may be specified with a cutout option. Cutout works with separately specified Oblong Planter (Lower top may not be specified with Planter).

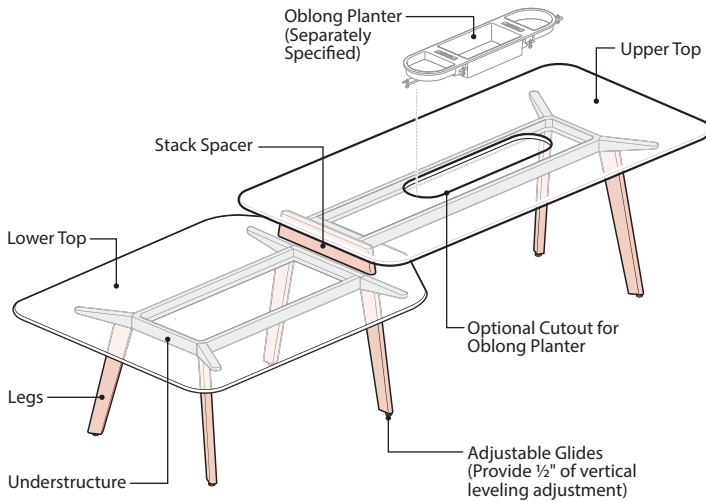

Dimensions Top View

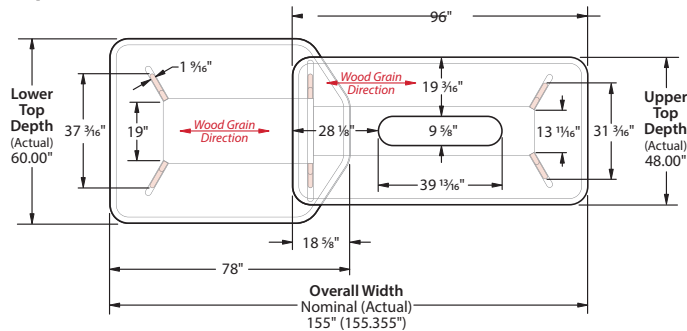

Front View

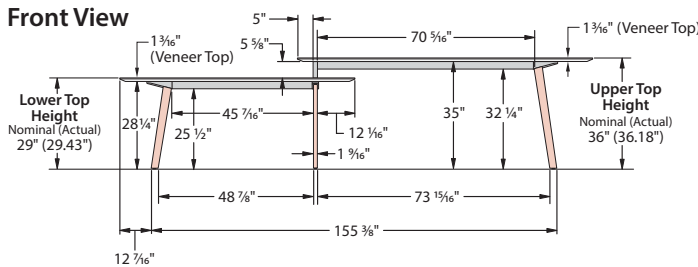

Seating Capacity

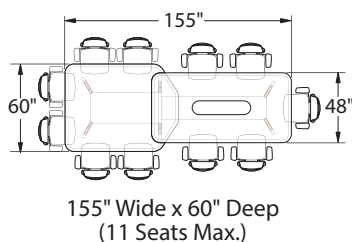

Component Materials and Finishes

COMPONENT NAME	MATERIALS/FINISHES	
Upper Top (Rectangle with Knife Edge)	Laminate	Standard Core - specify laminate finish/color and a separate edge finish/color.
	Painted	MDF Core - specify paint finish.
	Solid Surface	Wood Core – with built up solid surface edge. Standard in Cameo White.
Lower Top (Rectangle with Knife Edge)	Wood	Standard Core - specify a single color/finish for the surface and edge finishes.
	Laminate	Standard Core - specify surface finish/color and a separate edge finish color.
	Solid Surface	Wood core with built up Solid Surface edge - Standard in Cameo White.
Legs	Solid Wood	Ink on Ash (M7-W43) Clear on White Oak (M5-W35) Clear on Walnut (M6-W35)
	Painted	Painted metal – specified trim color
Stack Spacer	See Stack Spacer section below	
Understructure	Painted Metal with specified trim color	
Adjustable Glides	Standard in Black	

Stack Spacer Finish

- The Stack Spacer may be specified with any Stack Spacer paint finish, except when both tops are specified with a laminate finish.
- EXCEPTION: when the upper and lower tops are both specified with a laminate finish, the Stack Spacer paint finish will be pre-defined to coordinate with the understructure trim color.

UNDERSTRUCTURE TRIM COLOR (Specified)	PRE-DEFINED STACK SPACER PAINT FINISH (Only when both tops are laminate)
Black (TR-F)	Black (LN-F)
Charcoal (TR-K)	Black (LN-F)
Chartreuse (TR-CTS)	Chartreuse (LN-CTS)
Rusty Red (TR-RR)	Rusty Red (LN-RR)
Sable (TR-1M)	Sable (LN-1M)
Wren (TR-1K)	Wren (LN-1K)
All Other Trim Colors	Polar (LN-PL)

Table Heights

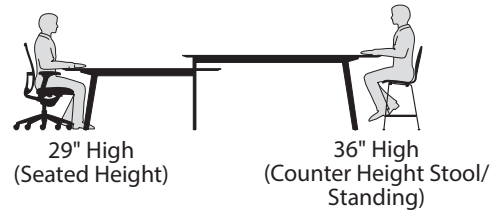

Optional Cutout for Oblong Planter

- For added storage and power specify cutout option (P) to accommodate a separately specified Oblong Planter.
- The Oblong Planter may be specified with or without power.

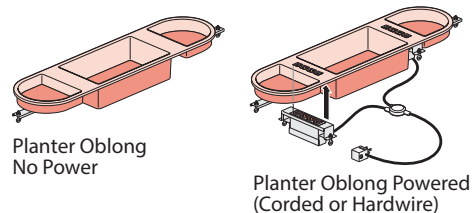

Product Details – Immerse Tables

Shift Table

Rectangle / Round

- Includes a rectangle lower top, round upper top, (6) legs, understructure, adjustable glides, stack spacer and hardware.
- For storage and/or power access, the tops may be specified with cutout options. Lower cutouts works with separately specified Oblong Planter, Upper Top works with separately specified Round Planter.

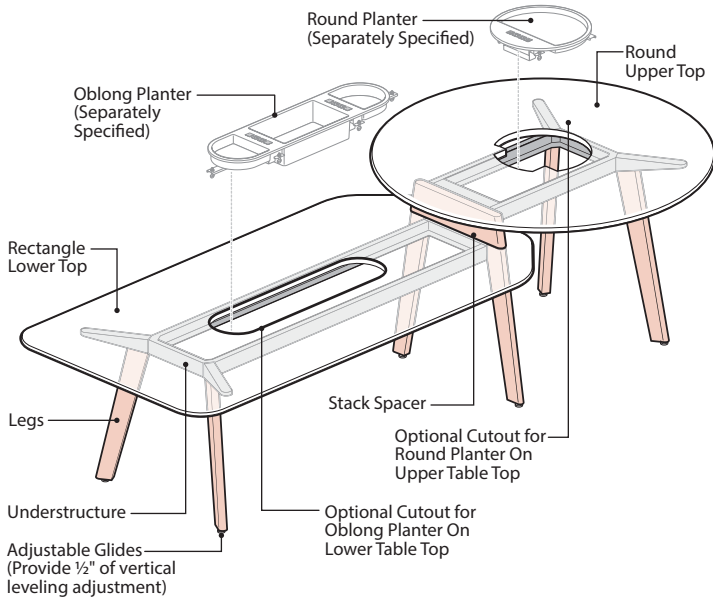

Dimensions Top View

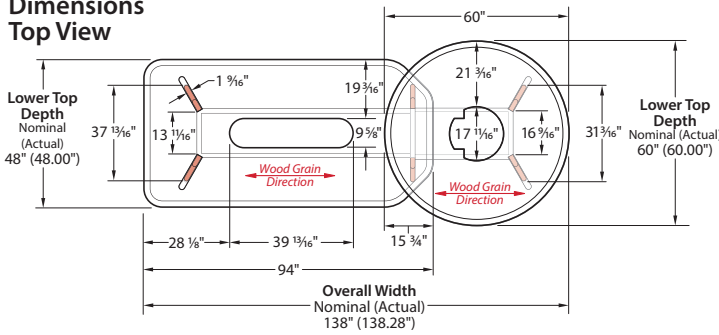

Front View

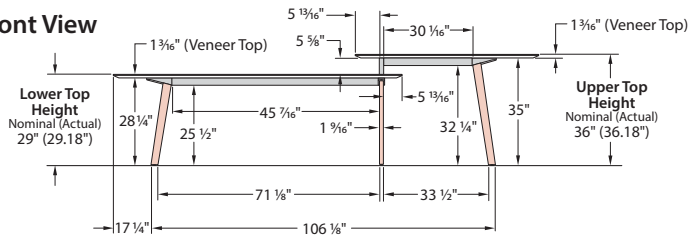

Seating Capacity

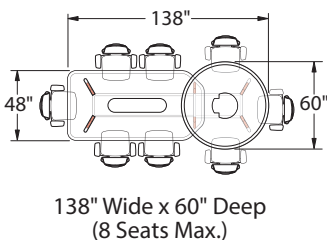

Component Materials and Finishes

COMPONENT NAME	MATERIALS/FINISHES	
Upper Top (Round with Knife Edge)	Laminate	Standard Core - specify surface finish/color and a separate edge finish color.
	Wood	Standard Core - specify a single color/finish for the surface and edge finishes.
	Solid Surface	Wood core with built up Solid Surface edge - Standard in Cameo White.
Lower Top (Rectangle with Knife Edge)	Laminate	Standard Core - specify laminate finish/color and a separate edge finish/color.
	Painted	MDF Core - specify paint finish.
	Solid Surface	Wood Core - with built up solid surface edge. Standard in Cameo White.
	Wood	Standard Core - specify a single color/finish for the surface and edge finishes.
Legs	Solid Wood	Ink on Ash (M7-W43) Clear on White Oak (M5-W35) Clear on Walnut (M6-W35)
	Painted	Painted metal - specified trim color
Stack Spacer	See Stack Spacer section below	
Understructure	Painted Metal with specified trim color	
Adjustable Glides	Standard in Black	

Stack Spacer Finish

- The Stack Spacer may be specified with any Stack Spacer paint finish, except when both tops are specified with a laminate finish.
- EXCEPTION: when the upper and lower tops are both specified with a laminate finish, the Stack Spacer paint finish will be pre-defined to coordinate with the understructure trim color.

UNDERSTRUCTURE TRIM COLOR (Specified)	PRE-DEFINED STACK SPACER PAINT FINISH (Only when both tops are laminate)
Black (TR-F)	Black (LN-F)
Charcoal (TR-K)	Black (LN-F)
Chartreuse (TR-CTS)	Chartreuse (LN-CTS)
Rusty Red (TR-RR)	Rusty Red (LN-RR)
Sable (TR-1M)	Sable (LN-1M)
Wren (TR-1K)	Wren (LN-1K)
All Other Trim Colors	Polar (LN-PL)

Table Heights

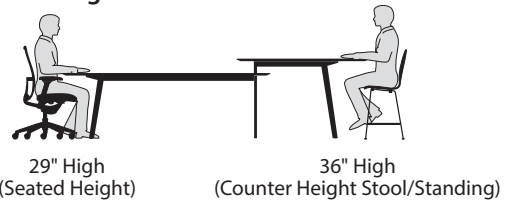

Optional Cutout for Oblong/Round Planters

- For added storage and power specify cutout option (P) to accommodate a separately specified Oblong and Round Planters.
- The Planters may be specified with or without power.

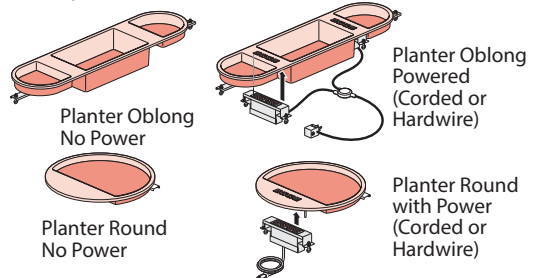

Product Details – Immerse Tables

Shift Table

Racetrack / Round

- Includes a racetrack shape lower top, round upper top, (6) legs, understructure, adjustable glides, stack spacer and hardware.
- For storage and/or power access, the tops may be specified with cutout options. Lower cutouts works with separately specified Oblong Planter, Upper Top works with separately specified Round Planter.

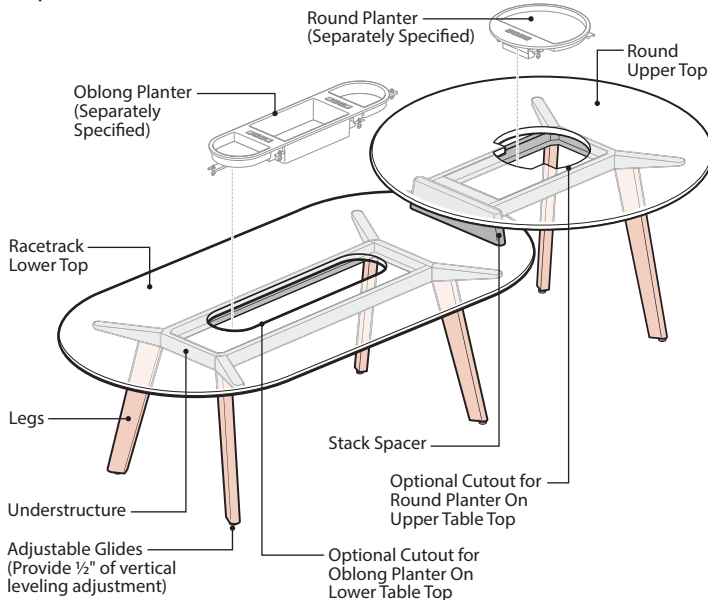

Dimensions Top View

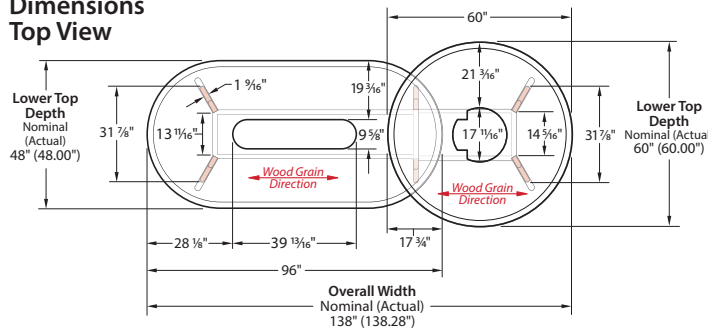

Front View

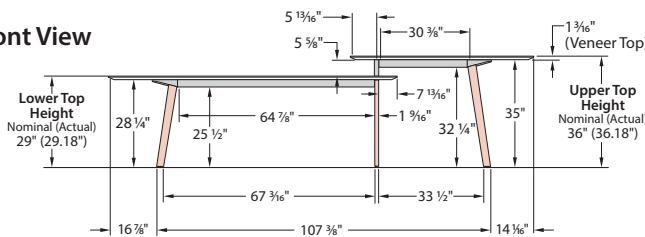

Seating Capacity

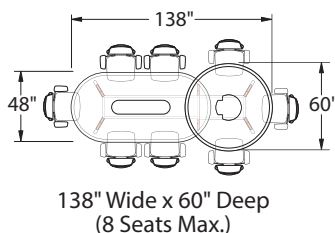

Component Materials and Finishes

COMPONENT NAME	MATERIALS/FINISHES	
Upper Top (Round with Knife Edge)	Laminate	Standard Core - specify surface finish/color and a separate edge finish color.
	Wood	Standard Core - specify a single color/finish for the surface and edge finishes.
	Solid Surface	Wood core with built up Solid Surface edge - Standard in Cameo White.
Lower Top (Racetrack with Knife Edge)	Laminate	Standard Core - specify laminate finish/color and a separate edge finish/color.
	Painted	MDF Core - specify paint finish.
	Solid Surface	Wood Core - with built up solid surface edge. Standard in Cameo White.
	Wood	Standard Core - specify a single color/finish for the surface and edge finishes.
Legs	Solid Wood	Ink on Ash (M7-W43) Clear on White Oak (M5-W35) Clear on Walnut (M6-W35)
	Painted	Painted metal - specified trim color
Stack Spacer	See Stack Spacer section below	
Understructure	Painted Metal with specified trim color	
Adjustable Glides	Standard in Black	

Stack Spacer Finish

- The Stack Spacer may be specified with any Stack Spacer paint finish, except when both tops are specified with a laminate finish.
- EXCEPTION: when the upper and lower tops are both specified with a laminate finish, the Stack Spacer paint finish will be pre-defined to coordinate with the understructure trim color.

UNDERSTRUCTURE TRIM COLOR (Specified)	PRE-DEFINED STACK SPACER PAINT FINISH (Only when both tops are laminate)
Black (TR-F)	Black (LN-F)
Charcoal (TR-K)	Black (LN-F)
Chartreuse (TR-CTS)	Chartreuse (LN-CTS)
Rusty Red (TR-RR)	Rusty Red (LN-RR)
Sable (TR-1M)	Sable (LN-1M)
Wren (TR-1K)	Wren (LN-1K)
All Other Trim Colors	Polar (LN-PL)

Table Heights

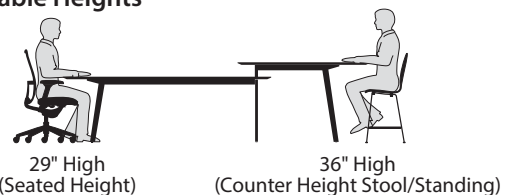

Optional Cutout for Oblong/Round Planters

- For added storage and power specify cutout options to accommodate a separately specified Oblong and/or Round Planter(s) (See Price List for cutout options).
- The Planters may be specified with or without power.

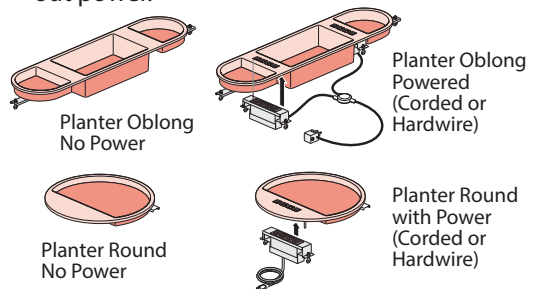

Product Details – Immerse Tables

Overlap Table

Rectangle / Rectangle

- Includes rectangle upper top, rectangle lower top, (6) legs, understructure, adjustable glides and hardware.
- For storage and/or power access, the upper top may be specified with a cutout option. Cutout works with separately specified Oblong Planter.

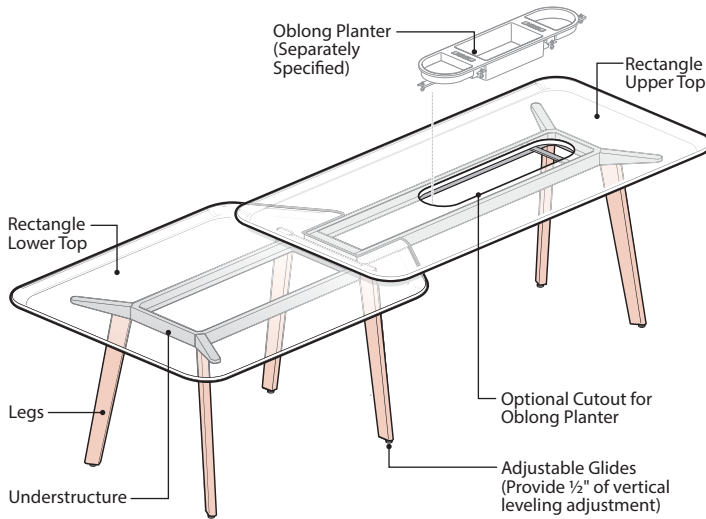

Dimensions Top View

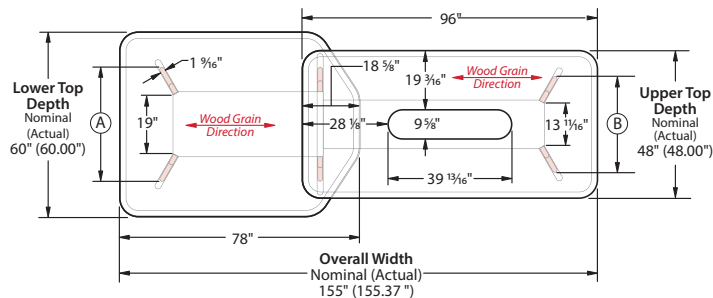

Front View

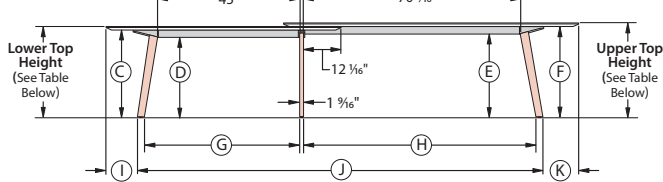

Dimensions by Table Size

Lower Top			Upper Top			Kneespace Dimensions										
Heights Nominal (Actual) (Veneer Top With glides fully recessed)	Depths (Actual)	Widths Nominal (Actual)	Heights Nominal (Actual) (Veneer Top With glides fully recessed)	Depths (Actual)	Widths (Actual)	A	B	C	D	E	F	G	H	I	J	K
29\"/>																

Component Materials and Finishes

COMPONENT NAME	MATERIALS/FINISHES	
Upper Top (Rectangle with Knife Edge)	Laminate	Standard Core - specify laminate finish/color and a separate edge finish/color.
	Painted	MDF Core - specify paint finish.
	Solid Surface	Wood Core - with built up solid surface edge. Standard in Cameo White.
Lower Top (Rectangle with Knife Edge)	Wood	Standard Core - specify a single color/finish for the surface and edge finishes.
	Solid Surface	Wood core with built up Solid Surface edge - Standard in Cameo White.
Legs	Solid Wood	Ink on Ash (M7-W43) Clear on White Oak (M5-W35) Clear on Walnut (M6-W35)
	Painted	Painted metal - specified trim color
Understructure	Painted Metal with specified trim color	
Adjustable Glides	Standard in Black	

Table Heights

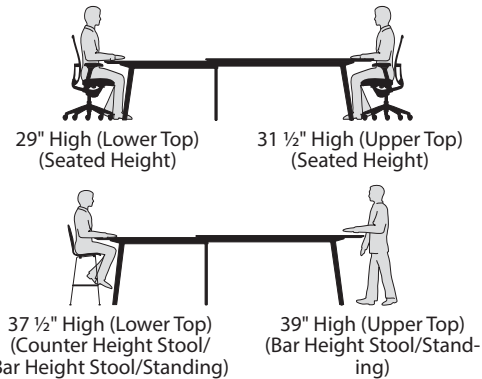

Seating Capacity

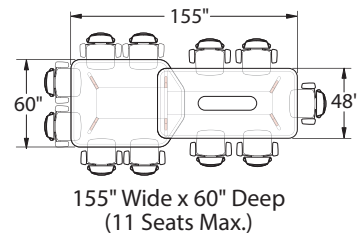

Optional Cutout for Oblong Planter

- For added storage and power specify cutout option to accommodate a separately specified Oblong Planter.
- The Oblong Planter may be specified with or without power.

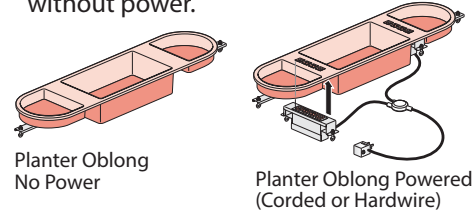

Product Details – Immerse Tables

Overlap Table

Rectangle / Round

- Includes round upper top, rectangle lower top, (6) legs, under-structure, adjustable glides and hardware.
- For storage and/or power access, the tops may be specified with cutout options. Lower cutouts works with separately specified Oblong Planter, Upper Top works with separately specified Round Planter.

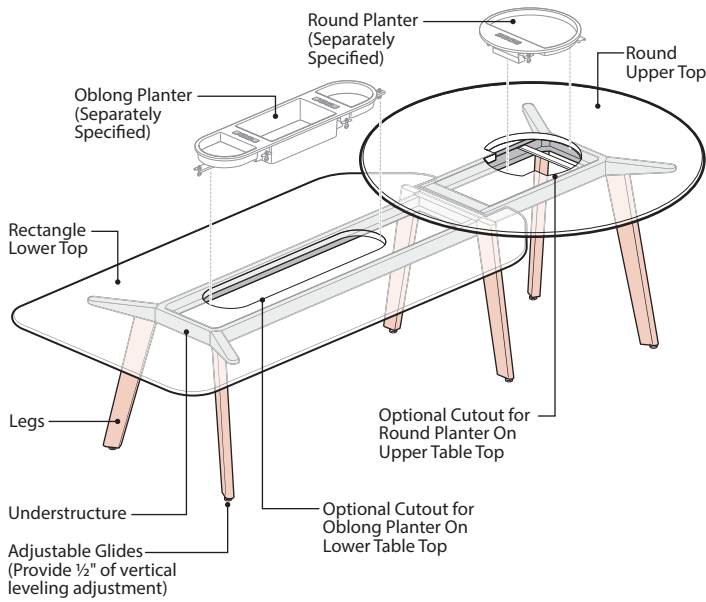

Dimensions Top View

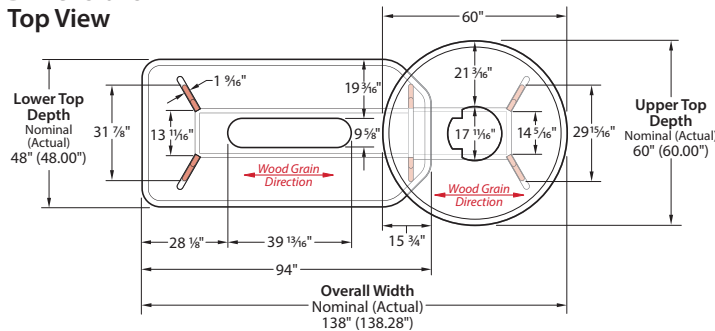

Front View

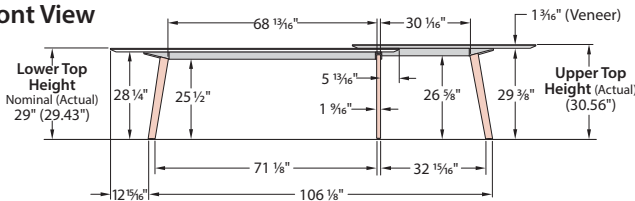

Component Materials and Finishes

COMPONENT NAME	MATERIALS/FINISHES	
Upper Top (Round with Knife Edge)	Laminate	Standard Core - specify surface finish/color and a separate edge finish color.
	Wood	Standard Core - specify a single color/finish for the surface and edge finishes.
	Solid Surface	Wood core with built up Solid Surface edge - Standard in Cameo White.
Lower Top (Rectangle with Knife Edge)	Laminate	Standard Core - specify laminate finish/color and a separate edge finish/color.
	Painted	MDF Core - specify paint finish.
	Solid Surface	Wood Core - with built up solid surface edge. Standard in Cameo White.
Legs	Solid Wood	Ink on Ash (M7-W43) Clear on White Oak (M5-W35) Clear on Walnut (M6-W35)
	Painted	Painted metal - specified trim color
Understructure	Painted Metal with specified trim color	
Adjustable Glides	Standard in Black	

Table Heights

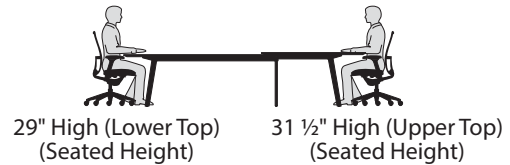

Seating Capacity

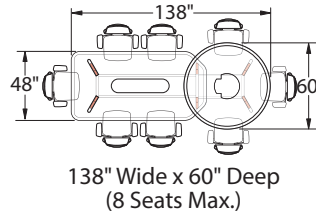

Optional Cutout for Oblong/Round Planters

- For added storage and power specify cutout options to accommodate a separately specified Oblong and/or Round Planter(s) (See Price List for cutout options).
- The Planters may be specified with or without power.

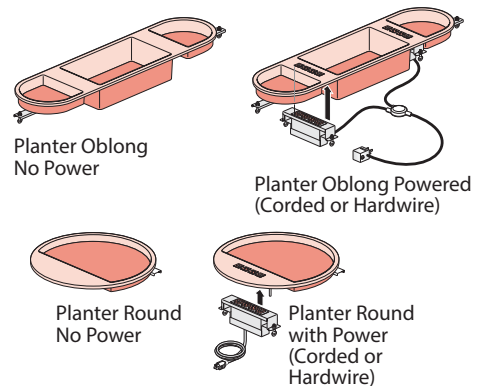

Product Details – Immerse Tables

Overlap Table

Racetrack / Round

- Includes racetrack shaped lower top, round upper top, (6) legs, understructure, adjustable glides and hardware.
- For storage and/or power access, the tops may be specified with cutout options. Lower cutouts works with separately specified Oblong Planter, Upper Top works with separately specified Round Planter.

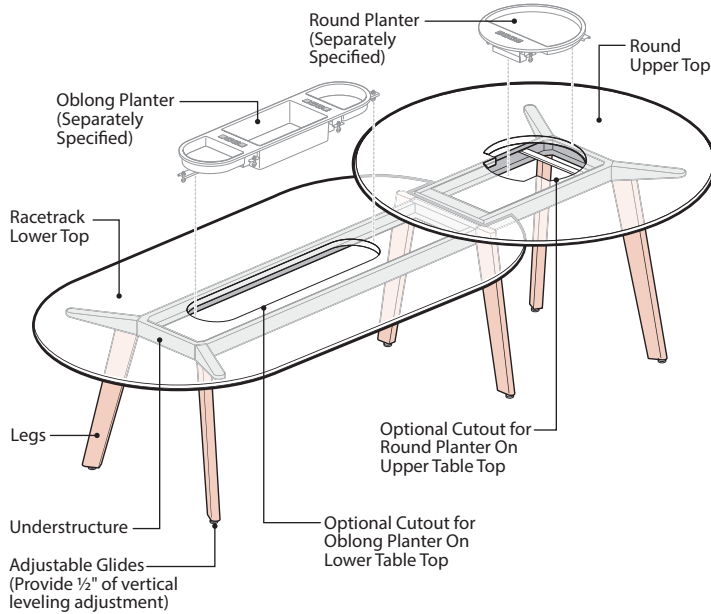

Dimensions Top View

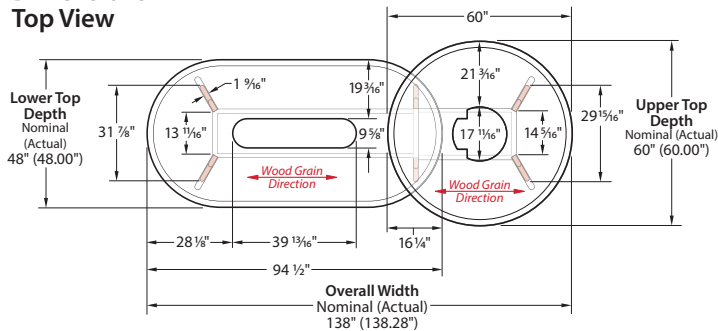

Front View

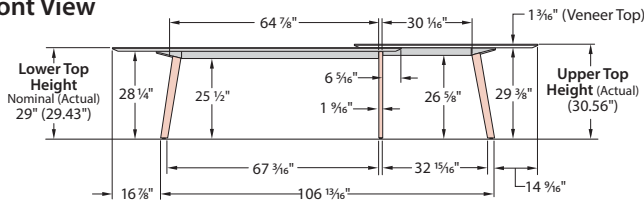

Component Materials and Finishes

COMPONENT NAME	MATERIALS/FINISHES	
Upper Top (Round with Knife Edge)	Laminate	Standard Core - specify surface finish/color and a separate edge finish color.
	Wood	Standard Core - specify a single color/finish for the surface and edge finishes.
	Solid Surface	Wood core with built up Solid Surface edge - Standard in Cameo White.
Lower Top (Racetrack with Knife Edge)	Laminate	Standard Core - specify laminate finish/color and a separate edge finish/color.
	Painted	MDF Core - specify paint finish.
	Wood	Standard Core - specify a single color/finish for the surface and edge finishes.
Legs	Solid Wood	Ink on Ash (M7-W43) Clear on White Oak (M5-W35) Clear on Walnut (M6-W35)
	Painted	Painted metal - specified trim color
Understructure	Painted Metal with specified trim color	
Adjustable Glides	Standard in Black	

Table Heights

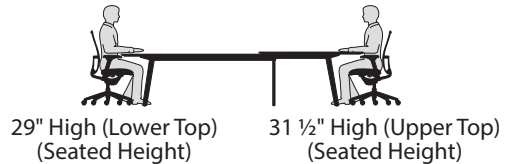

Seating Capacity

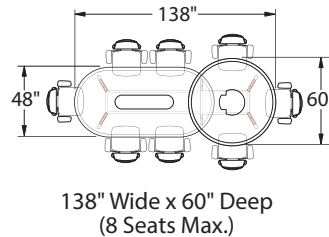

Optional Cutout for Oblong/Round Planters

- For added storage and power specify cutout options to accommodate a separately specified Oblong and/or Round Planter(s) (See Price List for cutout options).
- The Planters may be specified with or without power.

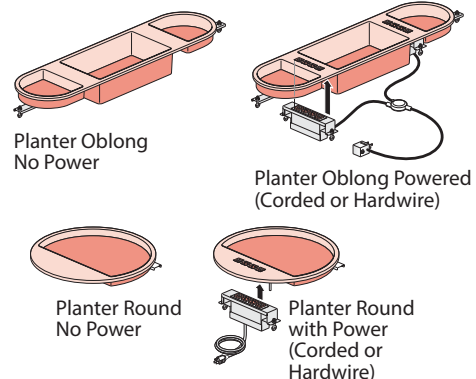

Product Details – Immerse Tables

Overlap Table

Rectangle / Ledge

- Includes ledge top (upper top), Rectangle top (lower top), (6) legs, understructure, adjustable glides and hardware.
- For storage and/or power access, the rectangle top may be specified with cutout option. The Rectangle top cutouts works with separately specified Oblong Planter.

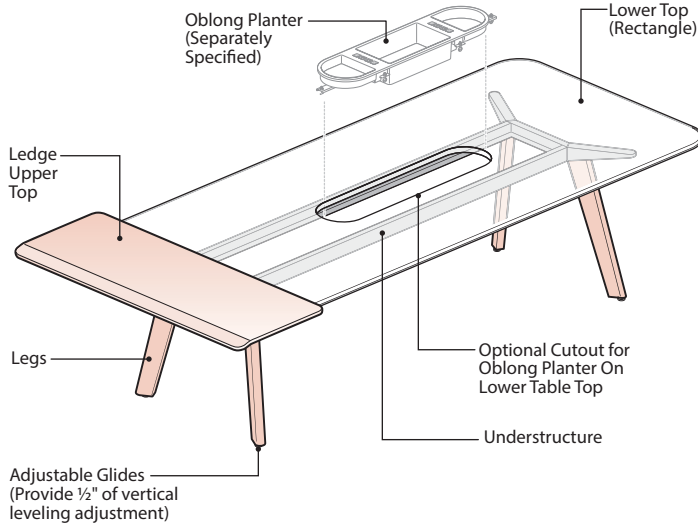

Dimensions Top View

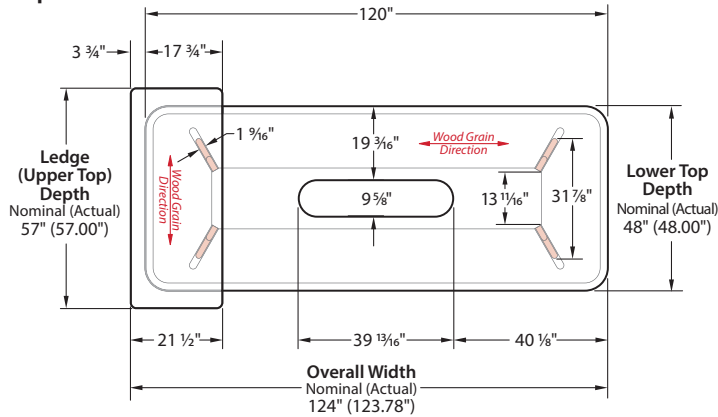

Front View

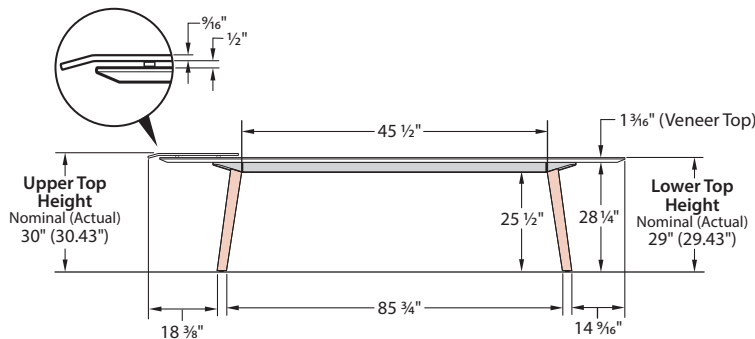

Component Materials and Finishes

COMPONENT NAME	MATERIALS/FINISHES	
Lower Top (Rectangle with Knife Edge)	Laminate	Standard Core - specify surface finish/color and a separate edge finish color.
	Wood	Standard Core - specify a single color/finish for the surface and edge finishes.
	Solid Surface	Wood core with built up Solid Surface edge - Standard in Cameo White.
Ledge Upper Top (Rectangle with Sealed Hardboard Laminated Edge)	Laminate	Laminated Hardboard Core with specified laminate top finish.
	Wood	Laminated Hardboard Core with specified wood veneer top finish.
Legs	Solid Wood	Ink on Ash (M7-W43) Clear on White Oak (M5-W35) Clear on Walnut (M6-W35)
	Painted	Painted metal - specified trim color
Understructure	Painted Metal with specified trim color	
Adjustable Glides	Standard in Black	

Table Heights

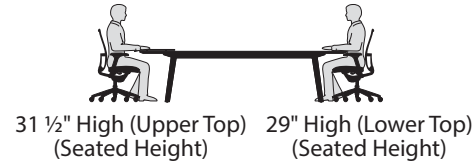

Seating Capacity

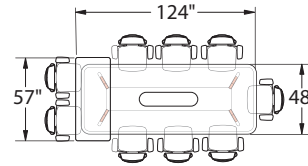

124" Wide x 57" Deep
(9 Seats Max.)

Optional Cutout for Oblong Planter

- For added storage and power specify cutout option to accommodate a separately specified Oblong Planter.
- The Oblong Planter may be specified with or without power.

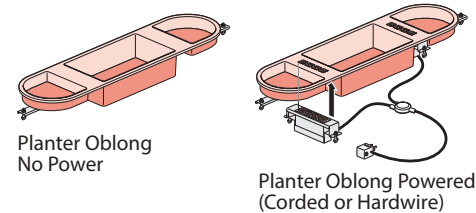

Product Details – Immerse Tables

Ledge Table

With Waterfall Edge

- Includes ledge top, (4) legs, understructure, adjustable glides and hardware.

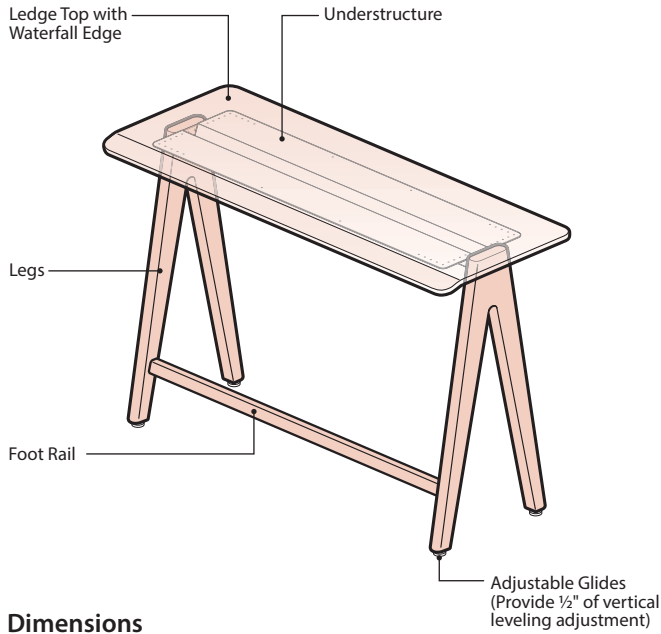

Component Materials and Finishes

COMPONENT NAME	MATERIALS/FINISHES	
Ledge Top (Rectangle with Sealed Hardboard Laminated Edge)	(L) Laminate	Laminated Hardboard Core with specified laminate top finish.
	(W) Wood	Laminated Hardboard Core with specified wood veneer top finish.
Legs	Solid Wood	Ink on Ash (M7-W43) Clear on White Oak (M5-W35) Clear on Walnut (M6-W35)
	Painted	Painted metal – specified trim color
Understructure and Foot Rail	Painted Metal with specified trim color	
Adjustable Glides	Standard in Black	

Table Height



36" High
(Counter Height
Stool/Standing)

Seating Capacity

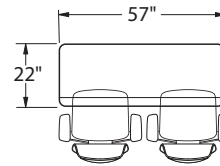

57" Wide x 22" Deep
(2 Seats Max.)

Dimensions Top View

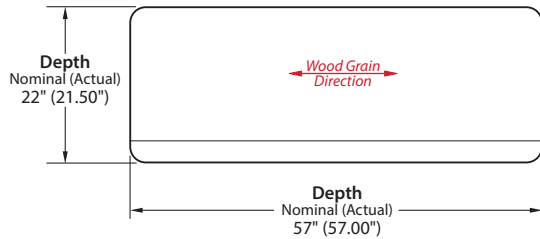

Front View

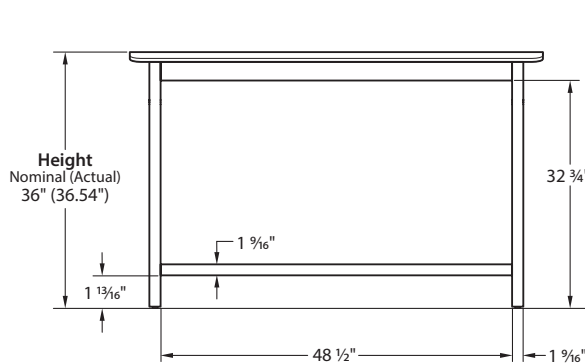

End View

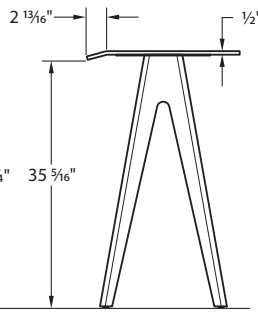

Product Details – Immerse Tables

Planter Oblong

No Power

- Includes oblong planter with (3) storage compartments, brackets and mounting Hardware.
- Designed to be installed in tables specified with the optional cutout for an Oblong Planter.
- Does not include Power Modules.

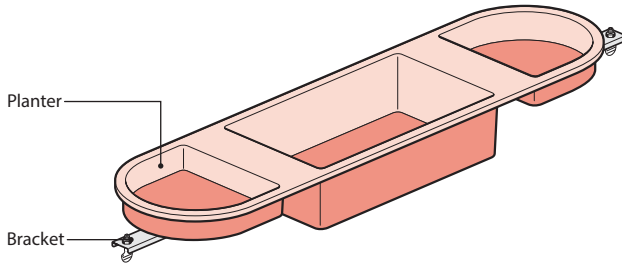

Powered – Corded or Hardwired

- Includes oblong planter with (3) storage compartments, (2) Power Modules (each with 4 ports), brackets and mounting Hardware.
- Designed to be installed in tables specified with the optional cutout for an Oblong Planter.

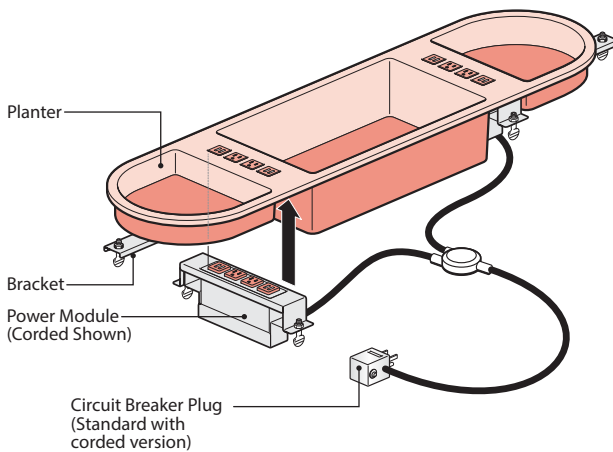

Dimensions Top View

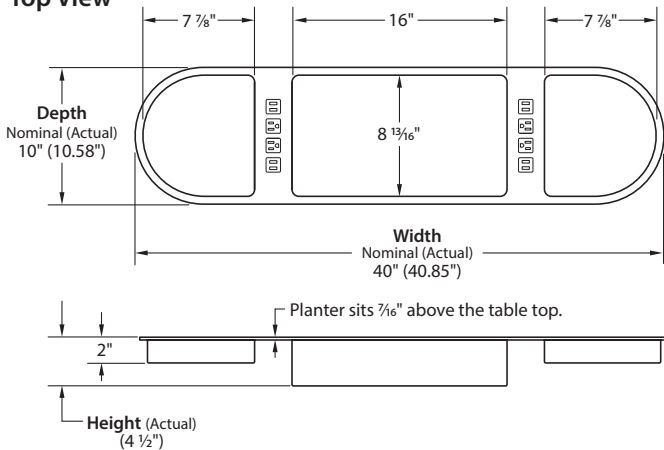

Component Materials and Finishes

COMPONENT NAME	MATERIALS/FINISHES	
Planter	Plastic	Black (TR-F) Gray Tone (TR-G) Smooth Plaster (TR-PLS) Terra Cotta (TR-TC)
Brackets	Painted Metal	Standard In Black

Component Materials and Finishes

COMPONENT NAME	MATERIALS/FINISHES	
Planter	Plastic	Black (TR-F) Gray Tone (TR-G) Smooth Plaster (TR-PLS) Terra Cotta (TR-TC)
Brackets	Painted Metal	Standard In Black
Power Module	Case and Bracket	Standard In Black
	Ports	Power Receptacle and USB Charging Ports are matched to the color of the Planter.
	Corded	Black Cord (6', 12' or 21' Long) with Circuit Breaker Plug.
	Hardwire	Galvanized Conduit (6' or 12' Long)

Power Module Configurations

- Power Modules may be specified corded with circuit breaker plug or hardwired.

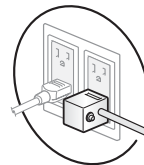

Corded with Circuit Breaker Plug (6', 12' or 21' Long)

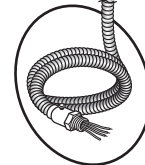

Hardwire (6' or 12' Long)

Power Module Port Configurations

- Includes 2 Power Modules with a total of 8 ports that can be configured with simplex outlets (NEMA-5-15R), or USB charging simplex outlets (with 2 USB outlets). No data or cable bay options are available.
- The specified port configuration will be the same on both Power Modules.

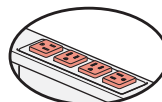

(4) Power Receptacles

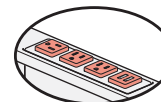

(3) Power Receptacles/
(1) USB Charging Port

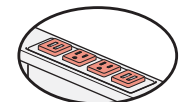

(2) Power Receptacles/
(2) USB Charging Ports

Product Details – Immerse Tables

Planter Round

No Power

- Includes planter with (1) storage compartment, brackets and mounting Hardware.
- Designed to be installed in tables specified with the optional cutout for an Round Planter.
- Does not include Power Module.

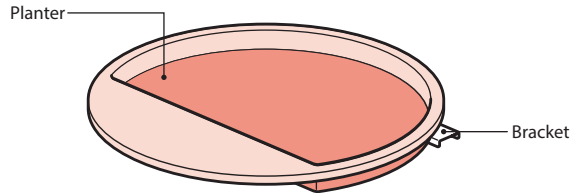

Powered – Corded or Hardwired

- Includes planter with (1) storage compartment, 4 Port Power Module with, brackets and mounting Hardware.
- Designed to be installed in tables specified with the optional cutout for an Oblong Planter.

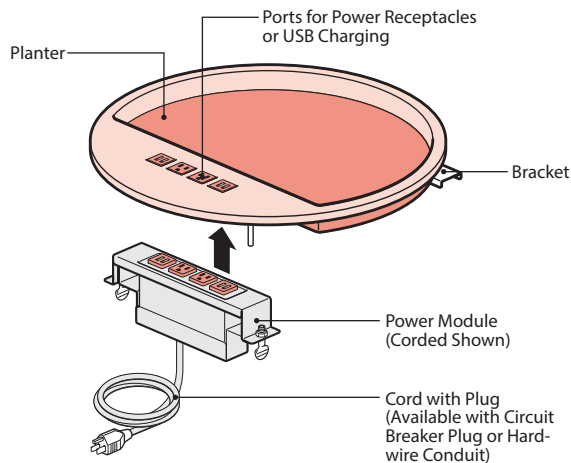

Dimensions Top View

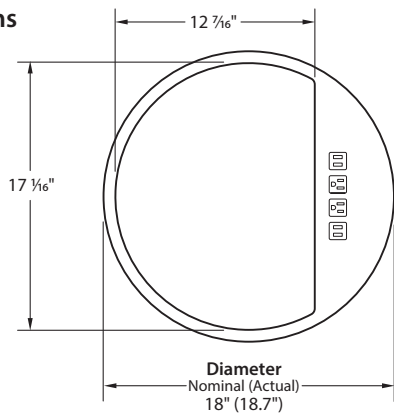

Front View

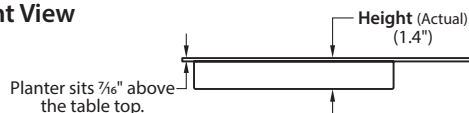

Component Materials and Finishes

COMPONENT NAME	MATERIALS/FINISHES	
Round Planter	Plastic	Black (TR-F) Gray Tone (TR-G) Smooth Plaster (TR-PLS) Terra Cotta (TR-TC)
Brackets	Painted Metal	Standard In Black

Component Materials and Finishes

COMPONENT NAME	MATERIALS/FINISHES	
Round Planter	Plastic	Black (TR-F) Gray Tone (TR-G) Smooth Plaster (TR-PLS) Terra Cotta (TR-TC)
Brackets	Painted Metal	Standard In Black
Power Module	Case and Bracket	Standard in Black
	Ports	Power Receptacle and USB Charging Ports are matched to the color of the Planter.
	Corded	Black Cord (6', 12' or 21' Long) with Plug. (Units with 4 power receptacles includes Circuit Breaker Plug)
	Hardwire	Galvanized Conduit (6' or 12' Long)

Power Module Configurations

- Power Modules may be specified corded with plug or hardwired.
- Power Modules with 4 power receptacles includes a circuit breaker plug.

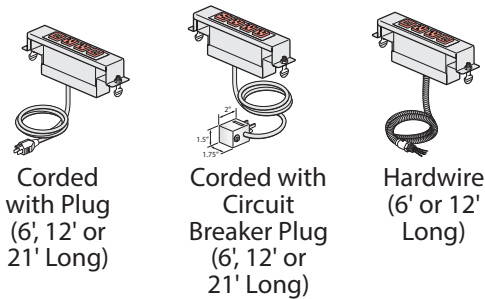

Power Module Port Configurations

- Includes Power Module with 4 ports that can be configured with simplex outlets (NEMA-5-15R), or USB charging simplex outlets (with 2 USB outlets). No data or cable bay options are available.

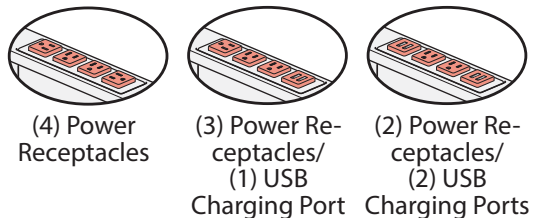

Specification Guide – Immerse Tables

Technical Specifications Section

Technical Specifications – Immerse Tables

Wood Composite Materials

All wood composite materials used in Immerse are engineered to meet or exceed ANSI requirements. Worksurfaces are composed of a minimum 90% wood fiber content with at least 10% post-consumer and 80% pre-consumer wood fiber bonded with resin. All parts with a wood composite core are 3rd party certified compliant with GREENGUARD® and ANSI/BIFMA Standards for low emitting products. The composite core is 3rd party certified compliant with California Air Resource Board (CARB) requirements for Phase 2 formaldehyde emission levels.

Laminate Tops

Standard core laminate tops are made with a .028 inch (.71 mm) HPL face, 1.125 inch (28.58 mm) medium density fiberboard (MDF) core and a .028 inch (.71 mm) HPL backer. Overall thickness is 1.181 inches (30 mm). The outer perimeter features a knife edge profile with 0.118 inch (3 mm) thick edgeband made of Acrylonitrile Butadiene Styrene (ABS). The edgeband is .375 inches (9.53 mm) tall with a 2.00 inch (50.8 mm), knife edge taper and is sealed with a clear finish.

Wood Tops

Standard Core Wood Tops feature a 0.020 inch (.51 mm) thick natural veneer or recon veneer face, 1.125 inch (28.58 mm) thick MDF core and a 0.020 inch (.51 mm) thick backer for balanced construction. Overall thickness is 1.165 inches (29.59 mm). The outer perimeter includes a knife edge profile with .100 (2.54 mm) inch thick wood edgeband. The edgeband is .375 inches (9.53 mm) tall with a 2.00 inch (50.8 mm), knife edge taper. The exception is the Stack table upper top knife edge with a .47 inch (11.94 mm) tall edge and a 3.00 inch (76.2 mm) taper. Wood tops are sealed with a water based finish.

Painted Tops

Standard Core Painted Tops feature a 1.125 inch (28.58 mm) thick MDF core painted on all sides. The outer perimeter has a knife edge profile with a 2.00 inch (50.8 mm) taper and no edgeband. Painted tops are not available in 60 inch (1524 mm) depths.

Solid Surface Tops

Solid surface tops include a .50 inch (12.7 mm) thick plywood core and a 3.00 inch (76.2 mm) or 4.00 inch (101.6 mm) built-up solid edge (depending on shape and frame). Overall thickness is 1.00 inch (25.4mm). Solid surface tops come in one, standard, Cameo White color. The outer perimeter has a knife edge profile without edgeband. The knife profile has a .375 inch (9.53 mm) tall flat and a 2.00 inch (50.8 mm) taper. The exception is the stack table upper top knife edge which features a .47 inch (11.94 mm) tall flat with a 3.00 inch (76.2 mm) taper.

Ledge Table Tops

Ledge tables feature a wood or laminate top with a formed waterfall edge. Wood Ledge tops are made with a .020 inch (.51 mm) veneer face, .504 inch (12.8 mm) thick high density fiberboard (HDF) core (8 layers, .063 inches (1.6 mm) each) and a .026 inch (.66 mm) thick backer. The overall thickness is .550 inches (13.97 mm). Wood Ledge tops do not have edgeband and are sealed with a water based finish. Laminate Ledge tops are made with a .028 inch (.71 mm) HPL face, .504 inch (12.8 mm) thick HDF core (8 layers, .063 inches (1.6 mm) each), and a .028 inch (.71 mm) HPL backer with an overall thickness of .560 inches (14.22 mm). Laminate tops feature a waxed edge with no edgeband.

Legs

The Immerse table line offers two options for legs. Painted (powder coated) steel legs made from 11 GA CRCS (available on all Immerse tables) and solid wood legs, made from 1.55 inch (39.37 mm) thick solid ash, white oak or walnut (available on all Immerse tables except for the Stack tables). Ash legs feature an ink stain and the white oak & walnut come standard with a clear water based finish.

Frame

Immerse framework and understructure are comprised of aluminum castings of approximately .20 inch (5.08 mm) thickness, and steel frame rails made from 14 GA CRCS. The Ledge table bracket and footrest are made from 11 GA CRCS.

Technical Specifications – Immerse Tables

Single Tables

Single tables are available in 4 different shapes. This includes round, square, rectangular one-piece, rectangular two-piece and racetrack. There are three heights available, which are 29.4 inches (747 mm), 36.2 inches (919 mm) and 39.2 inches (996 mm). The exception is the 144 inch (3658 mm) tables which are only available in 29.4 inch (747 mm) height). Glides, standard in black, offer an additional ½ inch (12.7 mm) of adjustment. Options for legs include both steel and solid wood versions. The surface options for each are laminate, painted (48 inch (1219 mm) depths only), solid surface and wood. Round and square 60 inch (1524 mm) tables have an optional round planter available with or without power. Rectangular and racetrack styles have an optional oblong planter with or without power.

Stack Tables

Stack tables feature a wood or solid surface upper top with a solid surface sill below or a laminate upper top with a laminate sill below. Available in two options, rectangular one-piece and rectangular two-piece. The height of the Stack table is 39.2 inches (996 mm) and width is 60 inches (1524 mm). Glides, standard in black, offer an additional ½ inch (12.7 mm) of adjustment. All versions of the Stack tables come standard with painted steel legs. The under-sill sits 3.32 inches (84.33 mm) below the upper surface at a 34.7 inch (881 mm) height. The solid surface sill is ½ inch (12.7 mm) thick. The Laminate sill is made with a .028 inch (.71 mm) HPL Face, .687 inch (17.45 mm) MDF core and a .028 inch (.71 mm) HPL backer with an overall thickness of .743 inches (18.87 mm). The perimeter of the laminate sill has a knife edge profile and includes a .039 inch (1.0 mm) thick edgeband made of ABS. The edgeband is .375 (9.53 mm) tall with a .914 inch (23.22 mm) taper. Stack tables have an optional oblong planter with or without power.

Shift Table

Shift tables feature two adjacent worktops with a 1.55 inch (39.37 mm) thick x 5.625 inch (142.88 mm) painted MDF spacer in-between. The three options for the shape of the worksurfaces include rectangle/rectangle, rectangle/round and racetrack/round. The height of the lower surface is standard at 29.4 inches (747 mm) and the upper surface at a height of 36.2 inches (919 mm). Glides, standard in black, offer an additional ½ inch (12.7 mm) of adjustment. Shift table leg options include both solid wood and painted steel, with surface options of painted (48 inch (1219 mm) depth tops only), laminate, wood veneer and solid surface. Shift tables can be specified with an optional planter. Round surfaces use the round planter available with or without power. Rectangular and racetrack styles have the oblong planter option. For the rectangle/rectangle option, the planter is only available in the upper surface.

Overlap Table

Overlap tables feature a dual-level workspace with two overlapping surfaces, the four options for the shapes of the worksurfaces are rectangle/rectangle, rectangle/round, racetrack/round and rectangle/ledge. The height of the rectangle/rectangle, rectangle/round and racetrack/round overlap tables are 29.4 inches (747 mm) for the lower surface and 30.6 inches (777 mm) for the upper surface. The rectangle/rectangle overlap can also be ordered in a taller height with the lower top being 38.0 inches (965 mm) and the upper top being 39.2 inches (996 mm) in height. The rectangle/ledge top heights are 29.4 inches (747 mm) for the lower top and 30.4 inches (772 mm) for the upper top. Glides, standard in black, offer an additional ½ inch (12.7 mm) of adjustment. Overlap table leg options include both solid wood and painted steel, with surface options of painted (48 inch (1219 mm) depth tops only), laminate, wood veneer and solid surface. Ledge upper tops only available in laminate or wood veneer. Overlap tables can be specified with an optional planter. Round surfaces use the round planter, available with or without power. Rectangular and racetrack styles use the oblong planter option, available with or without power. For the rectangle/rectangle option, the planter is only available on the upper surface.

Ledge Table

Ledge tables feature a wood veneer or laminate top with a formed waterfall edge. Ledge tables come standard at 36.1 inches (917mm) tall with worksurface dimensions of 21.50 inches (546 mm) x 57 inches (1448 mm) and include a painted steel foot rail. Glides, standard in black, offer an additional ½ inch (12.7 mm) of adjustment. Options for legs include both painted steel and solid wood versions.

Planter

Planters are available in two different shapes, round and oblong. Options include both powered and non-powered. Round planter powered versions come standard with a power module with 4 ports. Oblong Planter powered versions come standard with two modules with 4 ports in each. Power options cannot be modified in the field. Both corded and hardwired versions are available. Corded versions come with cord lengths of 6 feet, 12 feet (3658 mm) and 21 feet (6401 mm) long, hardwire versions come with galvanized conduit in length of 6 feet (1829 mm) or 12 feet (3658 mm). Planter color options include black, smooth plaster, gray tone and terra cotta, power modules are color matched. These are installed in the factory-cut work surfaces only. Planter material is plastic.

This page intentionally left blank.

Specification Guide – Jive Tables
Product Details Section

Product Details – Jive Tables

Overview

Jive Base Options and Top Shapes

Jive Tables are available with the following base options and Top Shapes:

Post Extruded Base Table

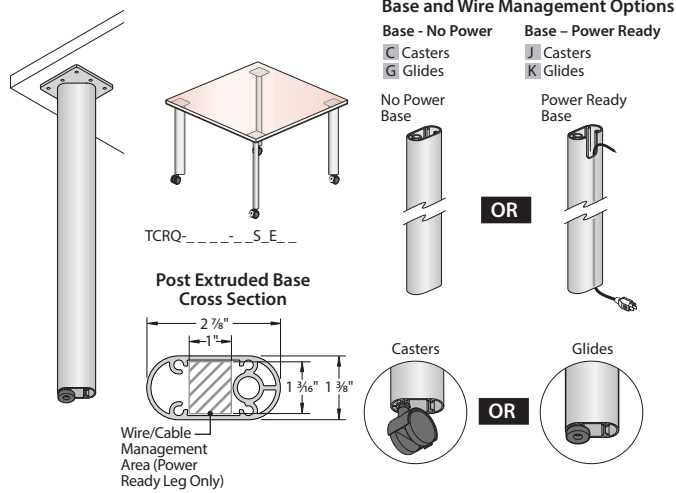

Top Shapes

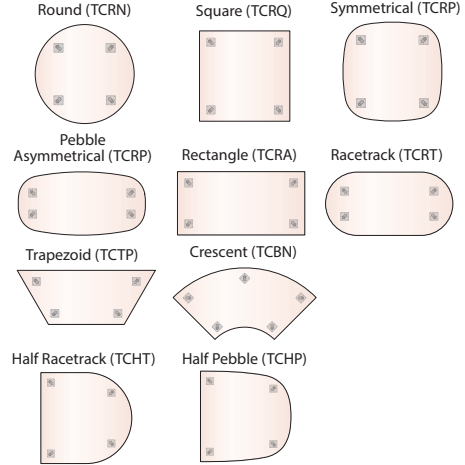

Post Round Base Table

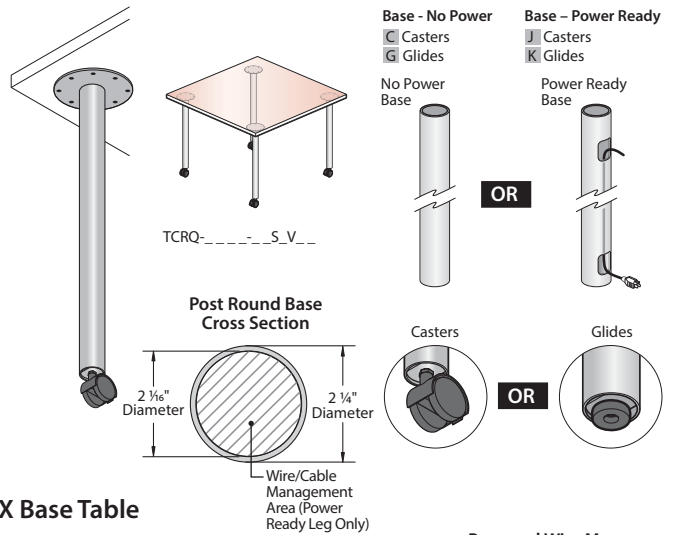

Top Shapes

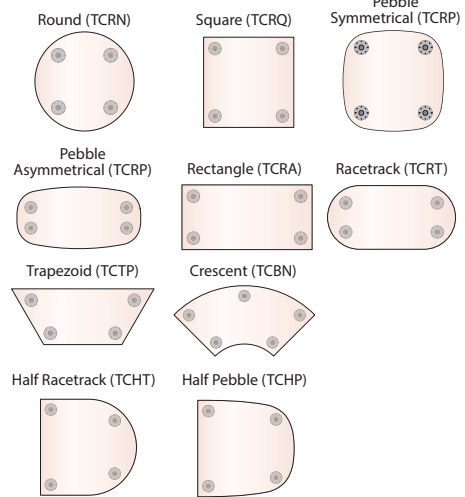

X Base Table

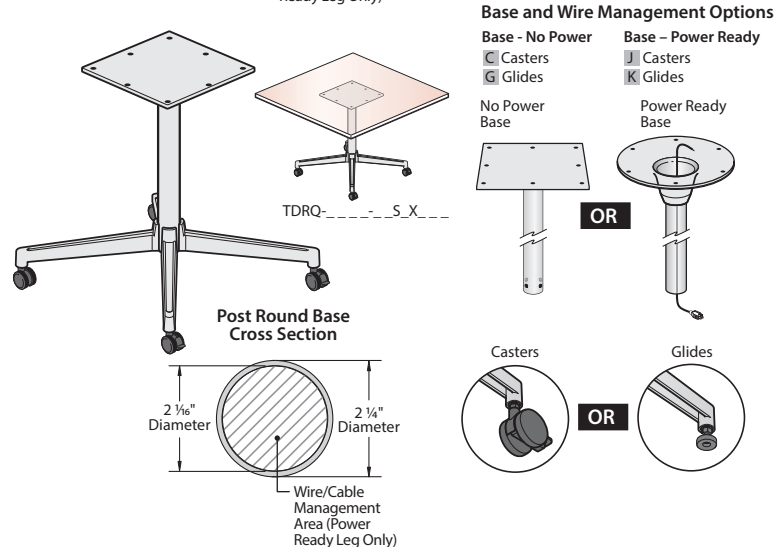

Top Shapes

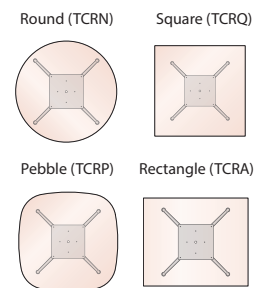

Product Details – Jive Tables

Overview

Jive Base Options and Top Shapes

Jive Tables are available with the following base options and Top Shapes:

Bridge Base Table

Base and Wire Management Options

Base - No Power
 C Casters
 G Glides

Base - Power Ready
 J Casters
 K Glides

No Power Base OR Power Ready Base

Casters OR Glides

Top Shapes

Round (4) Columns (TCRN)	Square (4) Columns (TCRQ)	Pebble Symmetrical (4) Columns (TCRP)
Racetrack (2) Columns (TCRP)	Rectangle (2) Columns (TCRA)	Pebble Asymmetrical (2) Columns (TCRP)
Racetrack (3) Columns (TCRT)	Rectangle (3) Columns (TCRA)	Pebble Asymmetrical (3) Columns (TCRP)
Racetrack (6) Columns (TCRT)	Rectangle (6) Columns (TCRA)	Pebble Asymmetrical (6) Columns (TCRP)
Racetrack (8) Columns (TCRT)	Rectangle (8) Columns (TCRA)	Pebble Asymmetrical (8) Columns (TCRP)
Half Hexagon (2) Columns (TCHX)	Half Racetrack (2) Columns (TCHT)	Half Racetrack (4) Columns (TCHT)
	Half Pebble (2) Columns (TCHP)	Half Pebble (4) Columns (TCHP)

Extruded C-Leg Table

Base and Wire Management Options

Base - No Power
 C Casters
 G Glides

Base - Power Ready
 J Casters
 K Glides

No Power Base OR Power Ready Base

Casters OR Glides

Top Shapes

Rectangle (TCRA)

Rectangle – Flip Base (TCRA)

Round C-Leg Table

Base and Wire Management Options

Base - No Power
 C Casters
 G Glides

Base - Power Ready
 J Casters
 K Glides

No Power Base OR Power Ready Base

Casters OR Glides

Top Shapes

Rectangle (TCRA)

Rectangle – Flip Base (TCRA)

Product Details – Jive Tables

Overview

Jive Base Options and Top Shapes

Jive Tables are available with the following base options and Top Shapes:

Disc Base Table

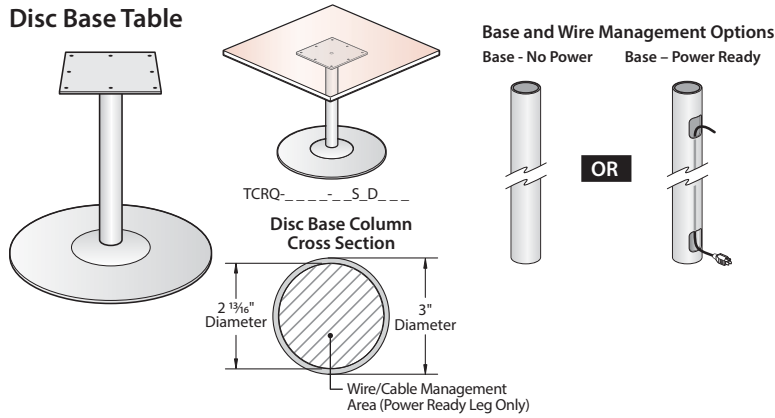

Disc Base Top Shapes

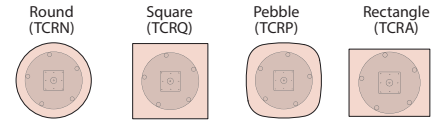

Dual Disc Base Top Shapes

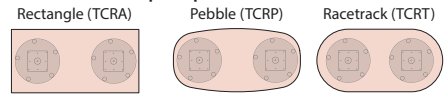

Extruded T-Leg Table

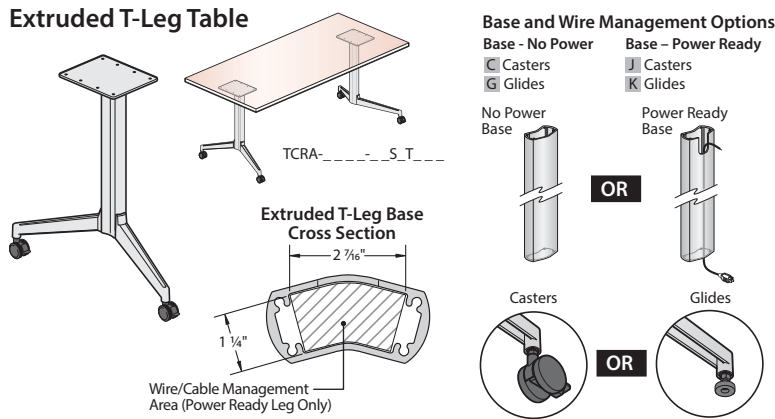

Top Shapes

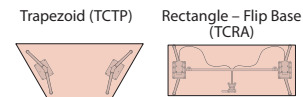
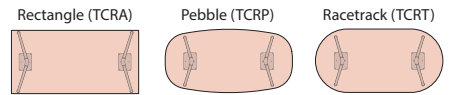

Round T-Leg Table

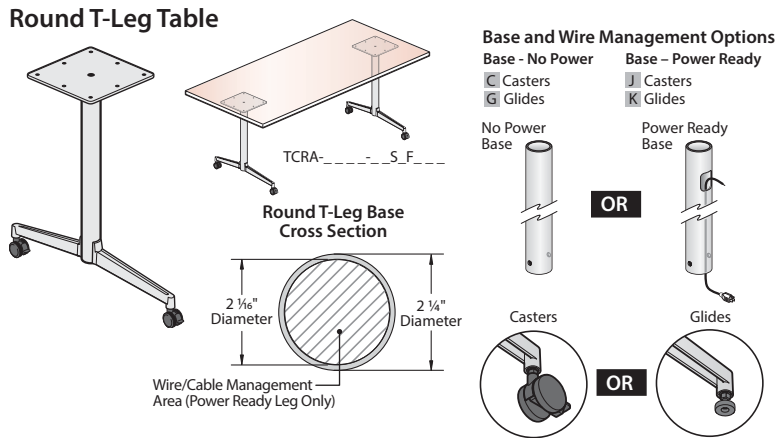

Top Shapes

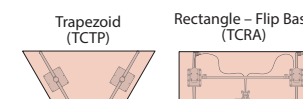
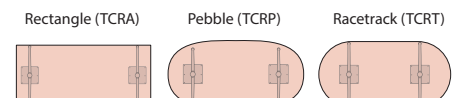

Swivel Base

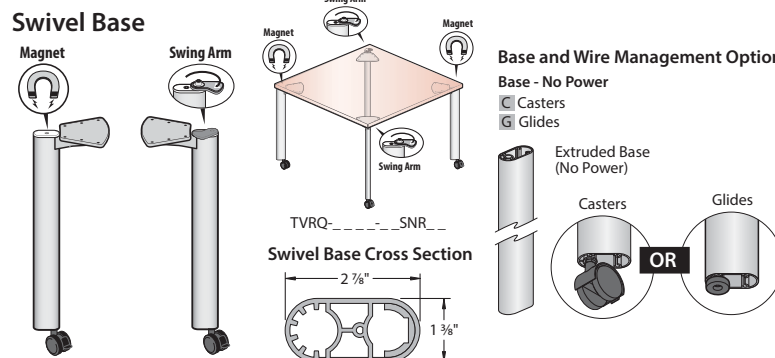

Top Shapes

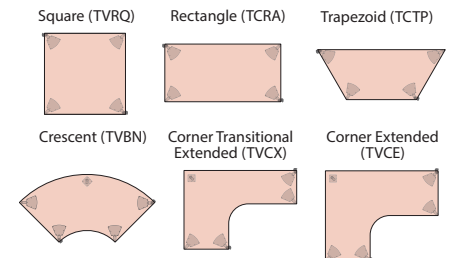

Product Details – Jive Tables

Overview

Jive Top Options

Surface Options

- Jive table tops are 1 3/16" thick and may be specified with a (L) Laminate or (W) Wood surfaces.

L Laminate

W Wood

Edge Options for Laminate Tops

- Requires separate specification for edge finish color.
- The Edge profile applied to all edges of the top (Exception: C-Leg Tables include the edge option on the user edge only with 1mm edgeband on remaining edges)

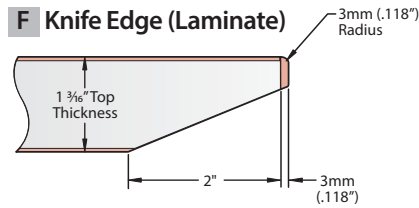
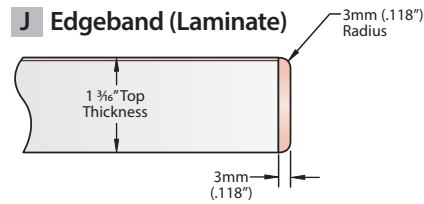

Edge Options for Wood Tops

- Edge defaults to specified Wood Top finish.
- The Edge profile applied to all edges of the top (Exception: C-Leg Tables include the edge option on the user edge only with 1mm edgeband on remaining edges)

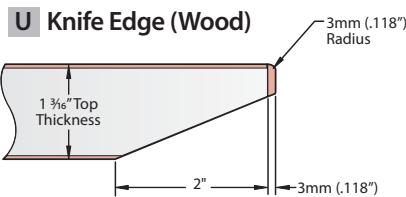
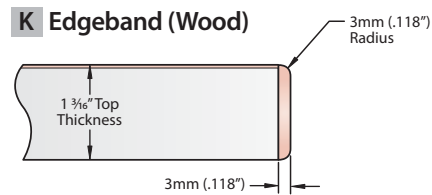

Product Details – Jive Tables

Overview

Electrical Components

Jive Tables may be used with following separately specified electrical components:

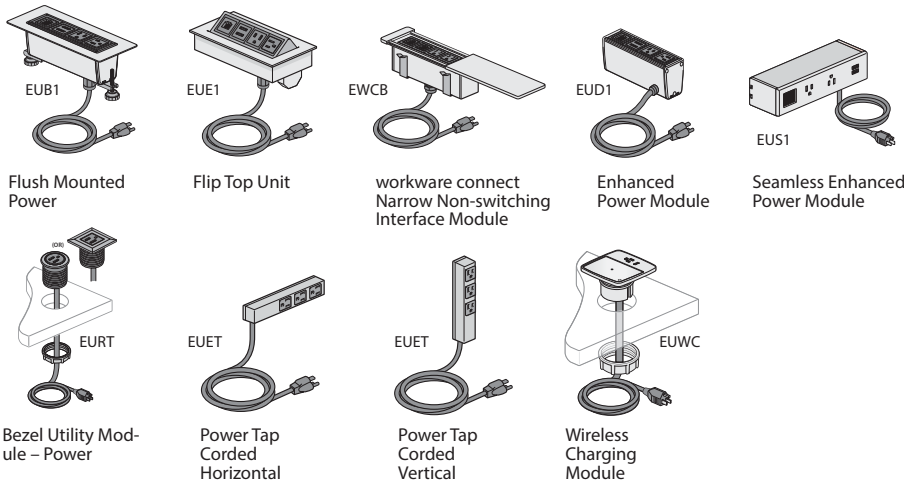

Electrical Component Brackets (Separately Specified)

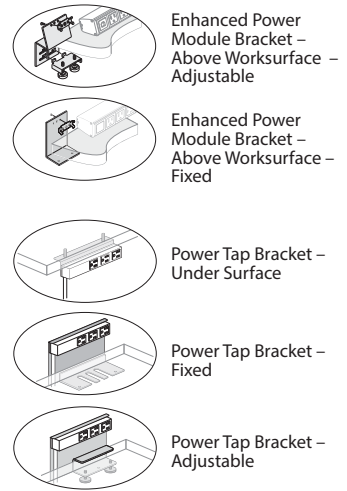

- Note**
- All of the options shown above must be field installed and many require field cut mounting holes in the top.
 - Ensure placement provides adequate clearance for table understructure (see product detail pages for dimensions).
 - Tops with Knife Edge are not for use with edge mounted brackets (Enhanced Power Module Brackets and Power Tap Brackets).
 - See the Accessories Price Book for the complete offering of Electrical Components and Accessories.

Wire Management

Separately specify wire management components to route cords and cables.

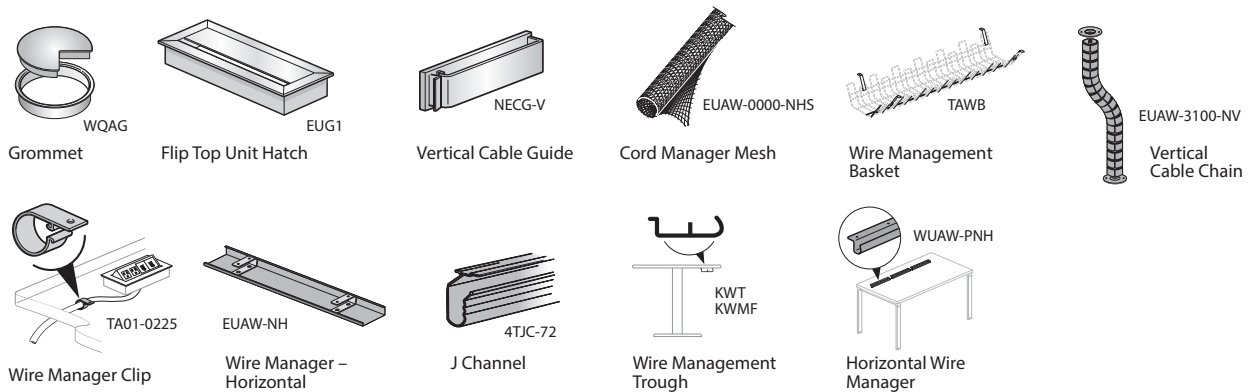

- Note**
- Wire management components must be field installed, ensure placement provides adequate clearance for table understructure (see product detail pages for dimensions).
 - See the Accessories Price Book for the complete offering of Wire Management Components.

Screens/Modesty Panels

Jive Tables may be used with following separately specified Screens and Modesty Panels:

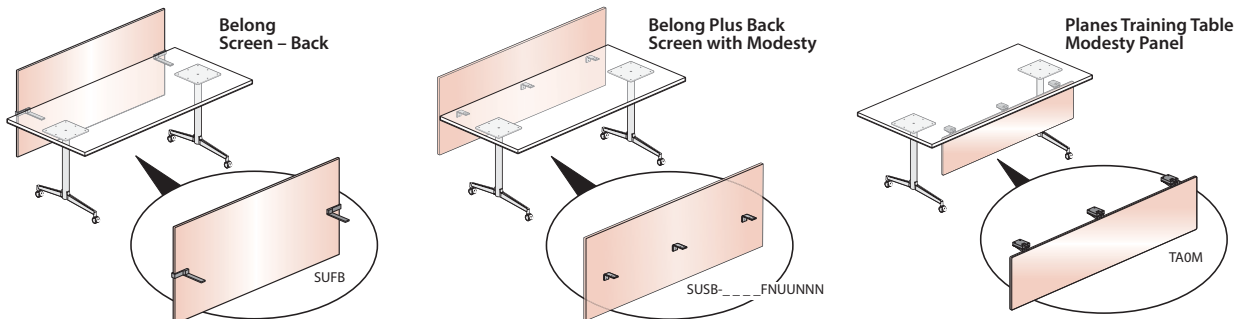

- Note**
- All Screens/Modesty Panels must be field installed, ensure placement provides adequate clearance for table understructure.
 - Screens/Modesty Panels are not for use on curved tops.
 - The Belong Plus Back Screen with Modesty (SUSB) cannot be used with tops specified with Knife Edge.

Product Details – Jive Tables

Post Extruded Base – Round (Top)

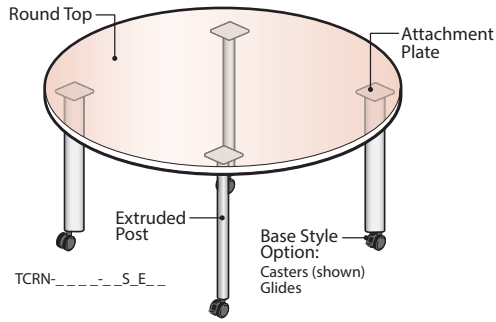

Component Materials/Finishes

COMPONENT NAME	MATERIALS/ FINISHES	
Round Top Edge Option is applied to all edges.	(L) Laminate – Specify separate top and edge finish colors.	(J) Edgeband
	(W) Wood – Specify a single finish color for top and edge.	(F) Knife
		(K) Edgeband
Post Extruded Base	Extruded Post	Painted Metal – Specify Base Trim Color
	Attachment Plates	Painted Metal – Standard in black
	Base Style	Casters – Standard in black. Glides – Standard in black.

Wood Grain Direction

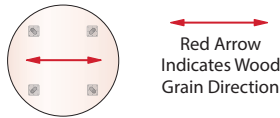

Top Cutout Options

- Power and Data access may be provided by specifying optional factory installed cutouts.
- Cutouts are designed to accommodate separately specified Flip Top Units.

Cutout Location

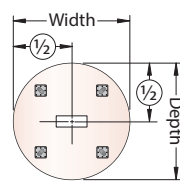

N No Cutout

F Center Power Cutout for 4-Port Single Sided Flip Top Unit

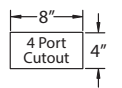

J Center Power Cutout for 6-Port Single Sided Flip Top Unit

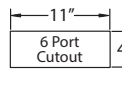

M Center Power Cutout for 8-Port Double Sided Flip Top Unit

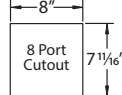

Q Center Power Cutout for 12-Port Double Sided Flip Top Unit

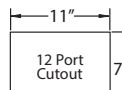

Base & Wire Management Options

Base - No Power

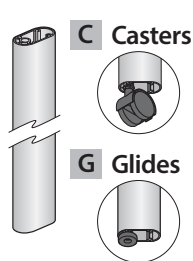

Does not provide access for cord management through the leg.

Base - Power Ready

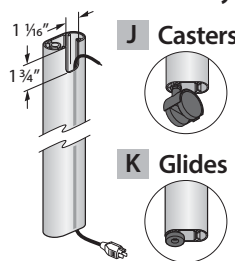

Provides access for cord management through (1) of the Post Extruded Legs. Power ready leg location determined during installation.

- Note**
- The finished height is the same when specified with either Casters or Glides.
 - Casters and Glides are not Interchangeable.

Sizes and Dimensions

Top View with Glides

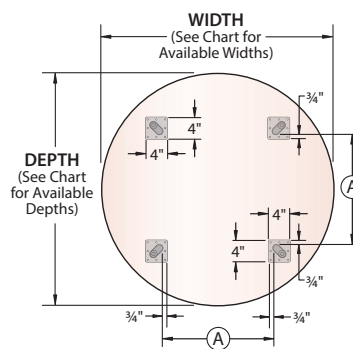

Front View with Glides

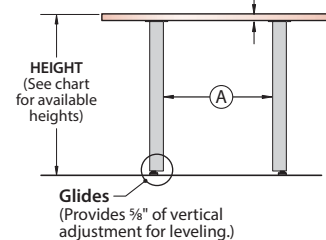

Front View with Casters

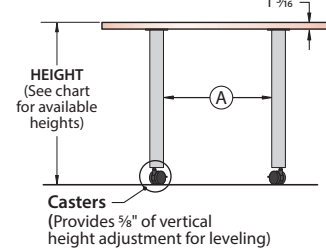

HEIGHT Nominal (Actual)	DEPTH Nominal (Actual)	WIDTH Nominal (Actual)	# of Legs	(A)
16" (15.94")	24" (23.68")	24" (23.68")	4	6 7/8"
	30" (29.68")	30" (29.68")	4	11 1/8"
	36" (35.68")	36" (35.68")	4	15 3/8"
	42" (41.68")	42" (41.68")	4	19 3/8"
	48" (47.68")	48" (47.68")	4	23 3/8"
20" (19.94")	24" (23.68")	24" (23.68")	4	6 7/8"
	30" (29.68")	30" (29.68")	4	11 1/8"
	36" (35.68")	36" (35.68")	4	15 3/8"
	42" (41.68")	42" (41.68")	4	19 3/8"
	48" (47.68")	48" (47.68")	4	23 3/8"
29" (28.94")	30" (29.68")	30" (29.68")	4	11 1/8"
	36" (35.68")	36" (35.68")	4	15 3/8"
	42" (41.68")	42" (41.68")	4	19 3/8"
	48" (47.68")	48" (47.68")	4	23 3/8"
	54" (53.68")	54" (53.68")	4	28 1/8"
60" (59.68")	60" (59.68")	4	32 3/8"	

Table Heights

29" High Tables

- Seated applications.
- Specify with standard height seating (17"-18" seat heights).



20" High Tables

- Seated/Lounge applications.
- Specify with standard/lounge height seating (14"-18" seat heights).

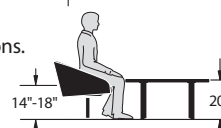

16" High Tables

- Seated/Lounge applications.
- Specify with standard/lounge height seating (14"-18" seat heights).

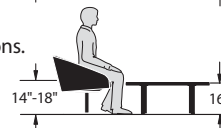

Product Details – Jive Tables

Post Extruded Base – Square (Top)

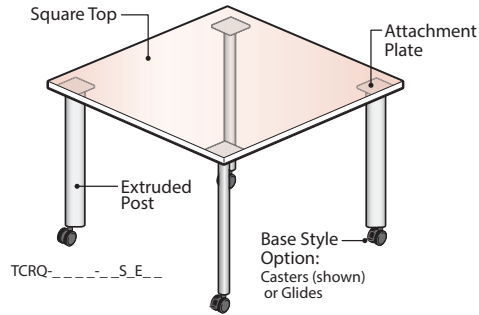

Component Materials/Finishes

COMPONENT NAME	MATERIALS/ FINISHES	
Square Top Edge Option is applied to all edges.	(L) Laminate – Specify separate top and edge finish colors.	(J) Edgeband
	(W) Wood – Specify a single finish color for top and edge.	(F) Knife
		(K) Edgeband
Post Extruded Base	Extruded Post	Painted Metal – Specify Base Trim Color
	Attachment Plates	Painted Metal – Standard in black
	Base Style	Casters – Standard in black. Glides – Standard in black.

Wood Grain Direction

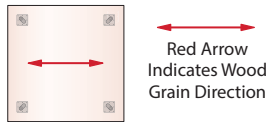

Top Cutout Options

- Power and Data access may be provided by specifying optional factory installed cutouts.
- Cutouts are designed to accommodate separately specified Flip Top Units.

Cutout Location

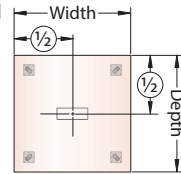

N No Cutout

F Center Power

Cutout for 4-Port Single Sided Flip Top Unit

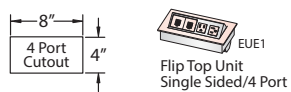

J Center Power

Cutout for 6-Port Single Sided Flip Top Unit

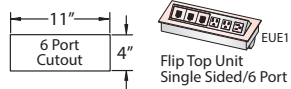

M Center Power

Cutout for 8-Port Double Sided Flip Top Unit

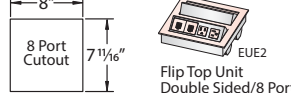

Q Center Power

Cutout for 12-Port Double Sided Flip Top Unit

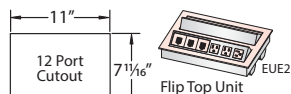

Base & Wire Management Options

Base - No Power

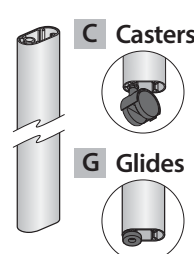

Does not provide access for cord management.

Base - Power Ready

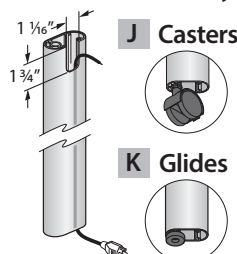

Provides access for cord management through (1) of the Post Extruded Legs. Power ready leg location determined during installation.

- Note**
- The finished height is the same when specified with either Casters or Glides.
 - Casters and Glides are not interchangeable.

Sizes and Dimensions

Top View with Glides

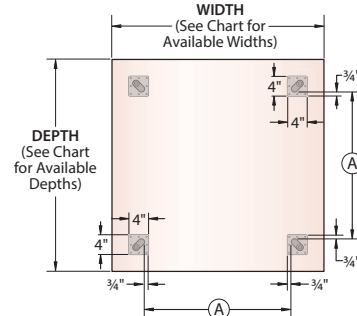

Front View with Glides

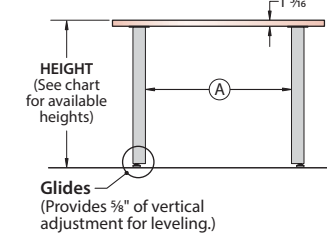

Front View with Casters

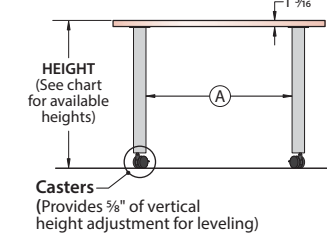

HEIGHT Nominal (Actual)	DEPTH Nominal (Actual)	WIDTH Nominal (Actual)	# of Legs	(A)
16" (15.94")	24" (23.68")	24" (23.68")	4	10 3/4"
	30" (29.68")	30" (29.68")	4	16 3/4"
	36" (35.68")	36" (35.68")	4	22 3/4"
	42" (41.68")	42" (41.68")	4	28 3/4"
	48" (47.68")	48" (47.68")	4	34 3/4"
20" (19.94")	24" (23.68")	24" (23.68")	4	10 3/4"
	30" (29.68")	30" (29.68")	4	16 3/4"
	36" (35.68")	36" (35.68")	4	22 3/4"
	42" (41.68")	42" (41.68")	4	28 3/4"
	48" (47.68")	48" (47.68")	4	34 3/4"
29" (28.94")	30" (29.68")	30" (29.68")	4	16 3/4"
	36" (35.68")	36" (35.68")	4	22 3/4"
	42" (41.68")	42" (41.68")	4	28 3/4"
	48" (47.68")	48" (47.68")	4	34 3/4"
	54" (53.68")	54" (53.68")	4	40 3/4"
	60" (59.68")	60" (59.68")	4	46 3/4"

Table Heights

29" High Tables

- Seated applications.
- Specify with standard height seating (17"-18" seat heights).

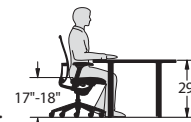

20" High Tables

- Seated/Lounge applications.
- Specify with standard/lounge height seating (14"-18" seat heights).

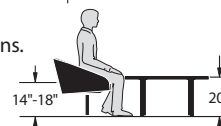

16" High Tables

- Seated/Lounge applications.
- Specify with standard/lounge height seating (14"-18" seat heights).

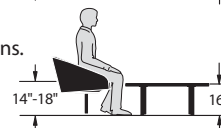

Product Details – Jive Tables

Post Extruded Base – Pebble Symmetrical (Top)

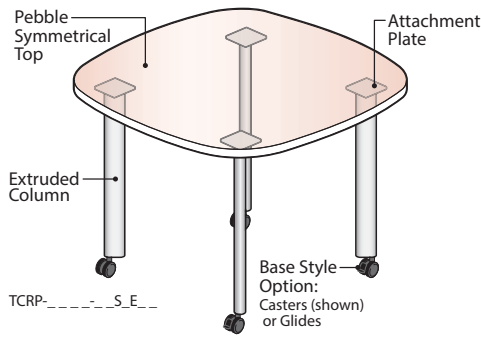

Component Materials/Finishes

COMPONENT NAME	MATERIALS/ FINISHES	
Pebble Symmetrical Top Edge Option is applied to all edges.	(L) Laminate – Specify separate top and edge finish colors.	(J) Edgeband
	(W) Wood – Specify a single finish color for top and edge.	(F) Knife
		(K) Edgeband
Post Extruded Base	Extruded Post	Painted Metal – Specify Base Trim Color
	Attachment Plates	Painted Metal – Standard in black
	Base Style	Casters – Standard in black. Glides – Standard in black.

Wood Grain Direction

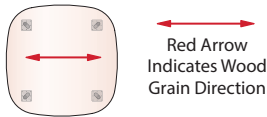

Top Cutout Options

- Power and Data access may be provided by specifying optional factory installed cutouts.
- Cutouts are designed to accommodate separately specified Flip Top Units.

N No Cutout

- F Center Power**
Cutout for 4-Port Single Sided Flip Top Unit

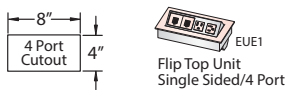

- J Center Power**
Cutout for 6-Port Single Sided Flip Top Unit

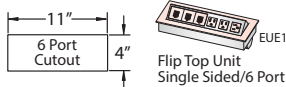

- M Center Power**
Cutout for 8-Port Double Sided Flip Top Unit

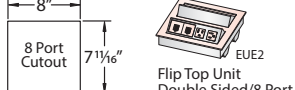

- Q Center Power**
Cutout for 12-Port Double Sided Flip Top Unit

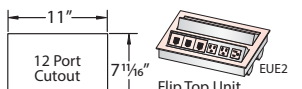

Base & Wire Management Options

Base - No Power Base - Power Ready

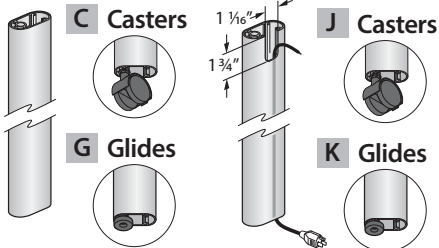

Does not provide access for cord management through the leg.

Provides access for cord management through (1) of the Post Extruded Legs. Power ready leg location determined during installation.

- Note**
- The finished height is the same when specified with either Casters or Glides.
 - Casters and Glides are not interchangeable.

Sizes and Dimensions

Top View with Glides

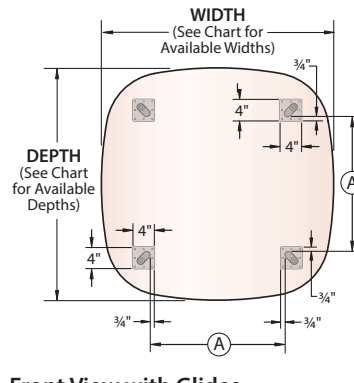

Front View with Glides

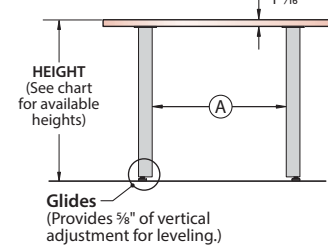

Front View with Casters

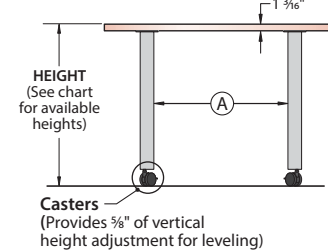

HEIGHT Nominal (Actual)	DEPTH Nominal (Actual)	WIDTH Nominal (Actual)	# of Legs	(A)
16" (15.94")	24" (23.68")	24" (23.68")	4	8 3/8"
	30" (29.68")	30" (29.68")	4	13 7/8"
	36" (35.68")	36" (35.68")	4	19 1/8"
	42" (41.68")	42" (41.68")	4	24 1/8"
	48" (47.68")	48" (47.68")	4	28 13/16"
20" (19.94")	24" (23.68")	24" (23.68")	4	8 3/8"
	30" (29.68")	30" (29.68")	4	13 7/8"
	36" (35.68")	36" (35.68")	4	19 1/8"
	42" (41.68")	42" (41.68")	4	24 1/8"
	48" (47.68")	48" (47.68")	4	28 13/16"
29" (28.94")	30" (29.68")	30" (29.68")	4	13 7/8"
	36" (35.68")	36" (35.68")	4	19 1/8"
	42" (41.68")	42" (41.68")	4	24 1/8"
	48" (47.68")	48" (47.68")	4	28 13/16"
	54" (53.68")	54" (53.68")	4	33 3/8"
	60" (59.68")	60" (59.68")	4	37 1/8"

Table Heights

29" High Tables

- Seated applications.
- Specify with standard height seating (17"-18" seat heights).

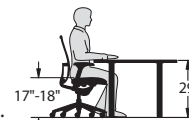

20" High Tables

- Seated/Lounge applications.
- Specify with standard/lounge height seating (14"-18" seat heights).

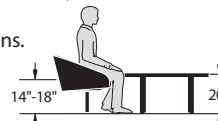

16" High Tables

- Seated/Lounge applications.
- Specify with standard/lounge height seating (14"-18" seat heights).

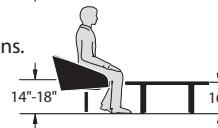

Product Details – Jive Tables

Post Extruded Base – Pebble Asymmetrical (Top)

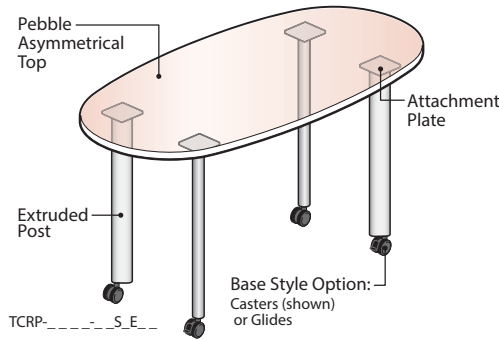

Wood Grain Direction

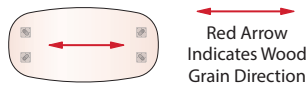

Top Cutout Options

- Power and Data access may be provided by specifying optional factory installed cutouts.
- Cutouts are designed to accommodate separately specified Flip Top Units

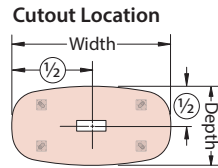

N No Cutout

F Center Power
Cutout for 4-Port Single Sided Flip Top Unit

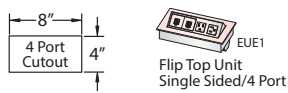

J Center Power
Cutout for 6-Port Single Sided Flip Top Unit

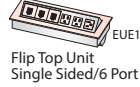
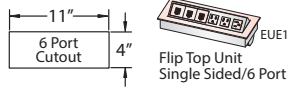

M Center Power
Cutout for 8-Port Double Sided Flip Top Unit

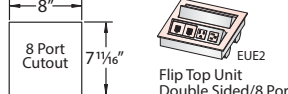

Q Center Power
Cutout for 12-Port Double Sided Flip Top Unit

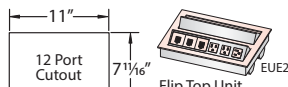

Base & Wire Management Options

Base - No Power

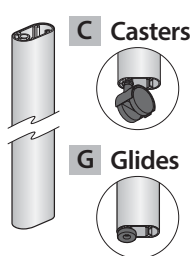

Does not provide access for cord management through the leg.

Base - Power Ready

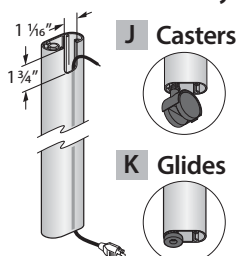

Provides access for cord management through (1) of the Post Extruded Legs. Power ready leg location determined during installation.

- Note**
- The finished height is the same when specified with either Casters or Glides.
 - Casters and Glides are not interchangeable.

Component Materials/Finishes

COMPONENT NAME	MATERIALS/ FINISHES	
Pebble Asymmetrical Top Edge Option is applied to all edges.	(L) Laminate – Specify separate top and edge finish colors.	(J) Edgeband
	(W) Wood – Specify a single finish color for top and edge.	(F) Knife
		(K) Edgeband
Post Extruded Base	Extruded Post	Painted Metal – Specify Base Trim Color
	Attachment Plates	Painted Metal – Standard in black
	Base Style	Casters – Standard in black. Glides – Standard in black.
		(U) Knife

Sizes and Dimensions

Top View with Glides

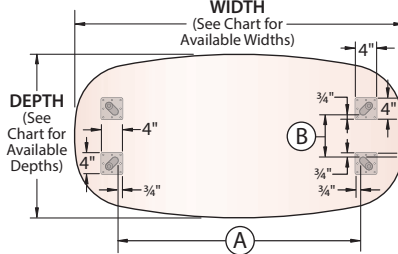

Front View with Glides

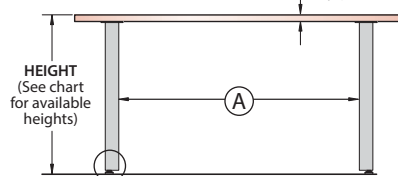

Glides
(Provides 3/8" of vertical adjustment for leveling.)

Front View with Casters

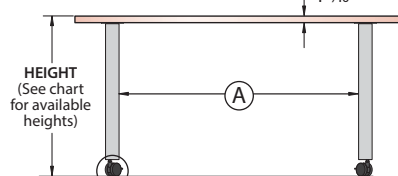

Casters
(Provides 3/8" of vertical height adjustment for leveling)

HEIGHT Nominal (Actual)	DEPTH Nominal (Actual)	WIDTH Nominal (Actual)	Component Dimensions	
			(A)	(B)
16" (15.94")	30" (29.68")	48" (47.68")	31 1/16"	7 13/16"
		60" (59.68")	43 11/16"	7 13/16"
	36" (35.68")	72" (71.68")	55 5/16"	7 13/16"
		60" (59.68")	43 11/16"	14 3/16"
20" (19.94")	30" (29.68")	48" (47.68")	31 1/16"	7 13/16"
		60" (59.68")	43 11/16"	7 13/16"
	36" (35.68")	72" (71.68")	55 5/16"	7 13/16"
		60" (59.68")	43 11/16"	14 3/16"
29" (28.94")	30" (29.68")	48" (47.68")	43 11/16"	7 13/16"
		60" (59.68")	43 11/16"	7 13/16"
	36" (35.68")	72" (71.68")	55 5/16"	14 3/16"
		60" (59.68")	43 11/16"	14 3/16"
42" (41.68")	72" (71.68")	55 5/16"	20 3/8"	
	48" (47.68")	72" (71.68")	55 5/16"	27 1/4"

Table Heights

29" High Tables

- Seated applications.
- Specify with standard height seating (17"-18" seat heights).



20" High Tables

- Seated/Lounge applications.
- Specify with standard/lounge height seating (14"-18" seat heights).

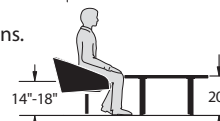

16" High Tables

- Seated/Lounge applications.
- Specify with standard/lounge height seating (14"-18" seat heights).

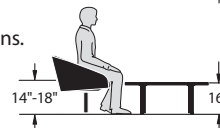

Product Details – Jive Tables

Post Extruded Base – Rectangle (Top)

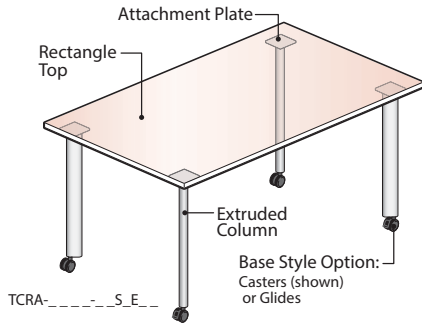

Component Materials/Finishes

COMPONENT NAME	MATERIALS/ FINISHES	
Rectangle Top Edge Option is applied to all edges.	(L) Laminate – Specify separate top and edge finish colors.	(J) Edgeband
	(W) Wood – Specify a single finish color for top and edge.	(F) Knife (K) Edgeband (U) Knife
Post Extruded Base	Extruded Post	Painted Metal – Specify Base Trim Color
	Attachment Plates	Painted Metal – Standard in black
	Base Style	Casters – Standard in black. Glides – Standard in black.

Wood Grain Direction



Top Cutout Options

- Power and Data access may be provided by specifying optional factory installed cutouts.
- Cutouts are designed to accommodate separately specified Flip Top Units

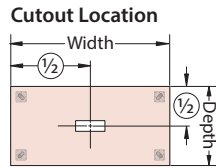

N No Cutout

F Center Power Cutout for 4 Port Single Sided Flip Top Unit

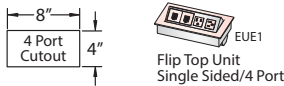

J Center Power Cutout for 6 Port Single Sided Flip Top Unit

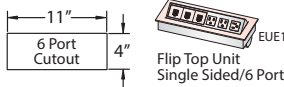

M Center Power Cutout for 8 Port Double Sided Flip Top Unit

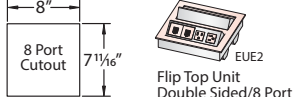

Q Center Power Cutout for 12 Port Double Sided Flip Top Unit

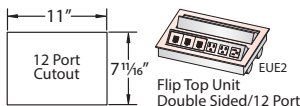

Base & Wire Management Options

Base - No Power

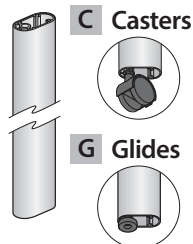

Does not provide access for cord management through the leg.

Base - Power Ready

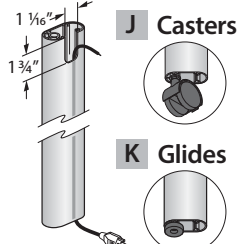

Provides access for cord management through (1) of the Post Extruded Legs. Power ready leg location determined during installation.

- Note**
- The finished height is the same when specified with either Casters or Glides.
 - Casters and Glides are not interchangeable.

Sizes and Dimensions

Top View with Glides

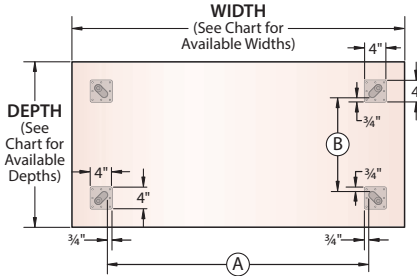

Front View with Glides

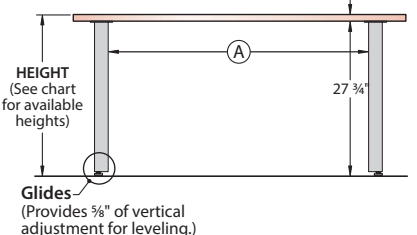

Front View with Casters

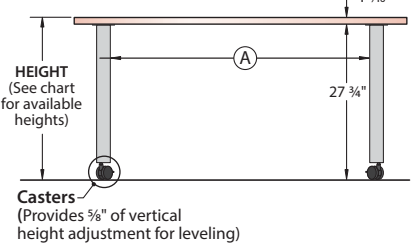

HEIGHT Nominal (Actual)	DEPTH Nominal (Actual)	WIDTH Nominal (Actual)	A	B
16" (15.94")	30" (29.68")	48" (47.68")	34 3/4"	16 3/4"
	54" (53.68")	40 3/4"	16 3/4"	
	60" (59.68")	46 3/4"	22 3/4"	
20" (19.94")	30" (29.68")	48" (47.68")	34 3/4"	16 3/4"
	54" (53.68")	40 3/4"	16 3/4"	
	60" (59.68")	46 3/4"	22 3/4"	
18" (17.68")	36" (35.68")	22 3/4"	10 3/4"	
	42" (41.68")	28 3/4"	10 3/4"	
	48" (47.68")	34 3/4"	10 3/4"	
24" (23.68")	54" (53.68")	40 3/4"	10 3/4"	
	60" (59.68")	46 3/4"	10 3/4"	
	66" (65.68")	52 3/4"	10 3/4"	
29" (28.94")	72" (71.68")	58 3/4"	10 3/4"	
	36" (35.68")	22 3/4"	16 3/4"	
	42" (41.68")	28 3/4"	16 3/4"	
30" (29.68")	48" (47.68")	40 3/4"	16 3/4"	
	54" (53.68")	40 3/4"	16 3/4"	
	60" (59.68")	46 3/4"	22 3/4"	
36" (35.68")	72" (71.68")	58 3/4"	22 3/4"	
	60" (59.68")	46 3/4"	22 3/4"	
	66" (65.68")	52 3/4"	22 3/4"	
42" (41.68")	72" (71.68")	58 3/4"	22 3/4"	
	60" (59.68")	46 3/4"	28 3/4"	

Table Heights

29" High Tables

- Seated applications.
- Specify with standard height seating (17"-18" seat heights).



20" High Tables

- Seated/Lounge applications.
- Specify with standard/lounge height seating (14"-18" seat heights).

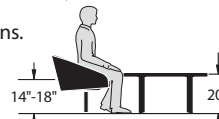

16" High Tables

- Seated/Lounge applications.
- Specify with standard/lounge height seating (14"-18" seat heights).

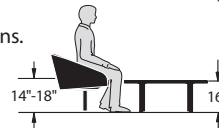

Product Details – Jive Tables

Post Extruded Base – Racetrack (Top)

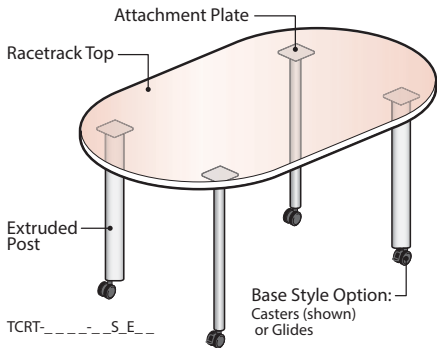

Wood Grain Direction

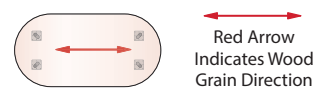

Top Cutout Options

- Power and Data access may be provided by specifying optional factory installed cutouts.
- Cutouts are designed to accommodate separately specified Flip Top Units

Cutout Location

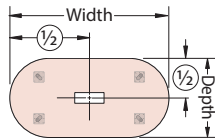

N No Cutout

F Center Power

Cutout for 4 Port Single Sided Flip Top Unit

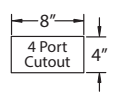

J Center Power

Cutout for 6 Port Single Sided Flip Top Unit

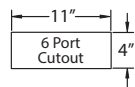

M Center Power

Cutout for 8 Port Double Sided Flip Top Unit

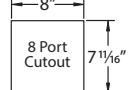

Q Center Power

Cutout for 12 Port Double Sided Flip Top Unit

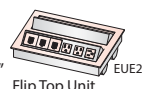
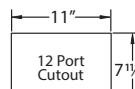

Base & Wire Management Options

Base - No Power

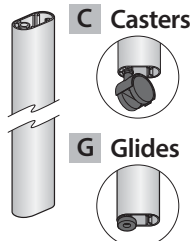

Does not provide access for cord management through the leg.

Base - Power Ready

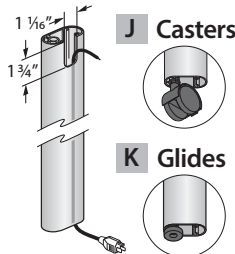

Provides access for cord management through (1) of the Post Extruded Legs. Power ready leg location determined during installation.

- Note**
- The finished height is the same when specified with either Casters or Glides.
 - Casters and Glides are not Interchangeable.

Component Materials/Finishes

COMPONENT NAME	MATERIALS/ FINISHES	
Racetrack Top Edge Option is applied to all edges.	(L) Laminate – Specify separate top and edge finish colors.	(J) Edgeband
	(W) Wood – Specify a single finish color for top and edge.	(F) Knife
		(K) Edgeband
Post Extruded Base	Extruded Post	Painted Metal – Specify Base Trim Color
	Attachment Plates	Painted Metal – Standard in black
	Base Style	Casters – Standard in black. Glides – Standard in black.

Sizes and Dimensions

Top View with Glides

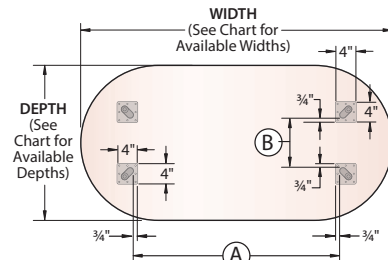

Front View with Glides

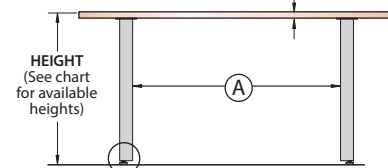

Glides (Provides 3/8" of vertical adjustment for leveling.)

Front View with Casters

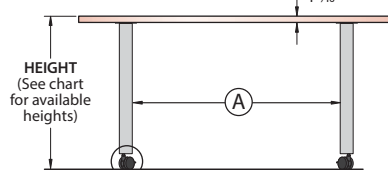

Casters (Provides 3/8" of vertical height adjustment for leveling)

HEIGHT Nominal (Actual)	DEPTH Nominal (Actual)	WIDTH Nominal (Actual)	Component Dimensions	
			(A)	(B)
16" (15.94")	30" (29.68")	48" (47.68")	29 1/8"	11 1/8"
		60" (59.68")	41 1/8"	11 1/8"
	36" (35.68")	60" (59.68")	39 3/8"	15 3/8"
		72" (71.68")	51 3/8"	15 3/8"
20" (19.94")	30" (29.68")	48" (47.68")	29 1/8"	13 3/16"
		60" (59.68")	41 1/8"	13 3/16"
	36" (35.68")	60" (59.68")	41 1/8"	19 3/16"
		72" (71.68")	53 1/8"	19 3/16"
29" (28.94")	30" (29.68")	48" (47.68")	29 1/8"	11 1/8"
		60" (59.68")	41 1/8"	11 1/8"
	36" (35.68")	60" (59.68")	39 3/8"	15 3/8"
		72" (71.68")	51 3/8"	15 3/8"
42" (41.68")	72" (71.68")	49 3/8"	19 3/8"	
	48" (47.68")	72" (71.68")	47 3/8"	23 3/8"

Table Heights

29" High Tables

- Seated applications.
- Specify with standard height seating (17"-18" seat heights).

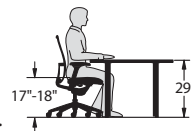

20" High Tables

- Seated/Lounge applications.
- Specify with standard/lounge height seating (14"-18" seat heights).

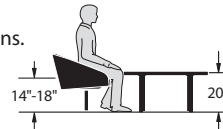

16" High Tables

- Seated/Lounge applications.
- Specify with standard/lounge height seating (14"-18" seat heights).

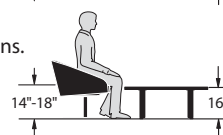

Product Details – Jive Tables

Post Extruded Base – Trapezoid (Top)

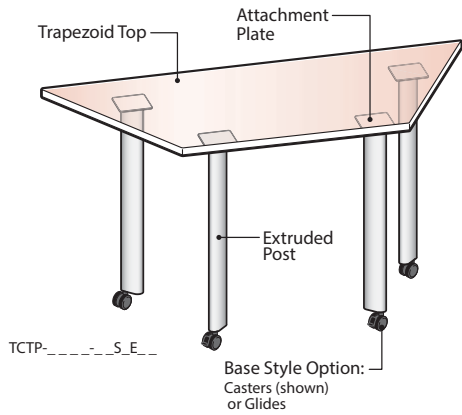

Component Materials/Finishes

COMPONENT NAME	MATERIALS/ FINISHES	
Trapezoid Top Edge Option is applied to all edges.	(L) Laminate – Specify separate top and edge finish colors.	(J) Edgeband
	(W) Wood – Specify a single finish color for top and edge.	(F) Knife
		(K) Edgeband (U) Knife
Post Extruded Base	Extruded Post	Painted Metal – Specify Base Trim Color
	Attachment Plates	Painted Metal – Standard in black
	Base Style	Casters – Standard in black. Glides – Standard in black.

Sizes and Dimensions

Top View

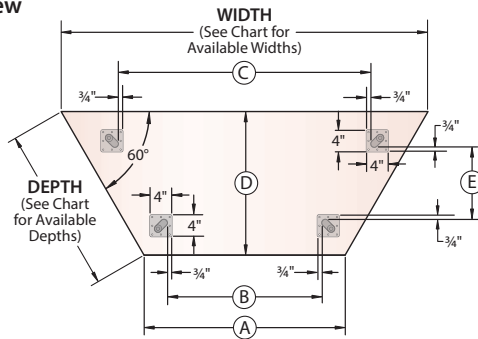

Wood Grain Direction

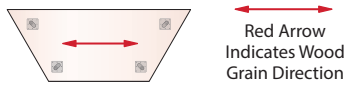

Top Cutout Options

- Power and Data access may be provided by specifying optional factory installed cutouts.
- Cutouts are designed to accommodate separately specified Flip Top Units

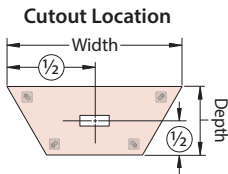

N No Cutout

F Center Power Cutout for 4 Port Single Sided Flip Top Unit

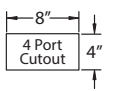

J Center Power Cutout for 6 Port Single Sided Flip Top Unit

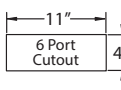

Base & Wire Management Options

Base - No Power

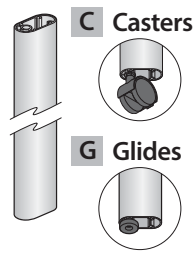

Does not provide access for cord management through the leg.

Base - Power Ready

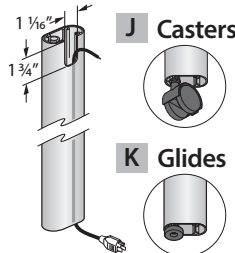

Provides access for cord management through (1) of the Post Extruded Legs. Power ready leg location determined during installation.

- Note**
- The finished height is the same when specified with either Casters or Glides.
 - Casters and Glides are not Interchangeable.

Front View with Glides

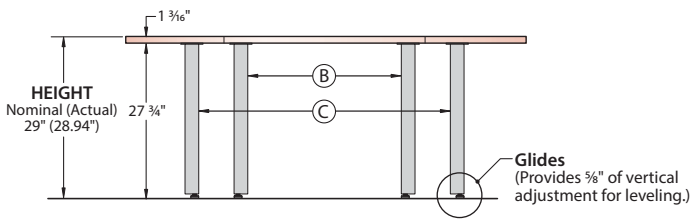

Front View with Casters

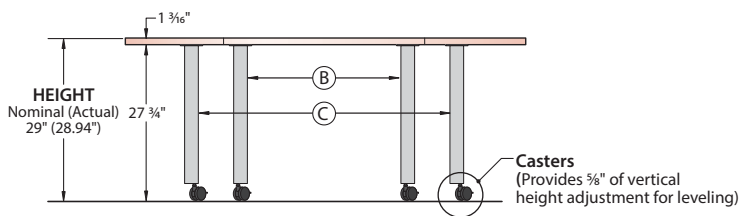

HEIGHT Nominal (Actual)	DEPTH Nominal (Actual)	WIDTH Nominal (Actual)	Component Dimensions				
			A	B	C	D	E
29" (28.94")	24" (23.68")	48" (47.68")	24"	15 1/2"	29 1/8"	20 1/2"	7 1/8"
		54" (53.68")	30"	21 1/2"	33 1/8"	20 1/2"	7 1/8"
		60" (59.68")	36"	27 1/2"	39 1/8"	20 1/2"	7 1/8"
	30" (29.68")	66" (65.68")	42"	33 1/2"	45 1/8"	20 1/2"	7 1/8"
		72" (71.68")	48"	39 1/2"	51 1/8"	20 1/2"	7 1/8"
		60" (59.68")	30"	21 1/2"	40 1/8"	25 1/8"	12 3/4"
36" (35.68")	66" (65.68")	36"	27 1/2"	46 1/8"	25 1/8"	12 3/4"	
	72" (71.68")	42"	33 1/2"	52 1/8"	25 1/8"	12 3/4"	

Table Heights

29" High Tables

- Seated applications.
- Specify with standard height seating (17"-18" seat heights).



Product Details – Jive Tables

Post Extruded Base – Crescent (Top)

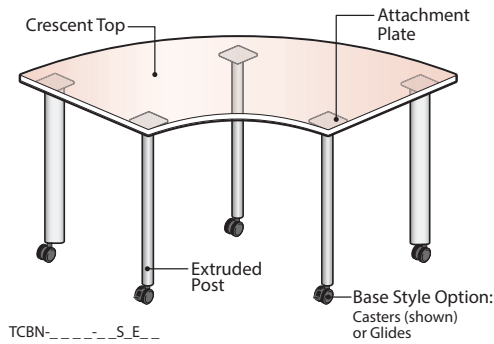

Wood Grain Direction

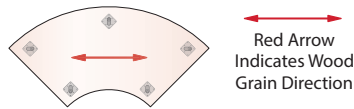

Top Cutout Options

- Power and Data access may be provided by specifying optional factory installed cutouts.
- Cutouts are designed to accommodate separately specified Flip Top Units.

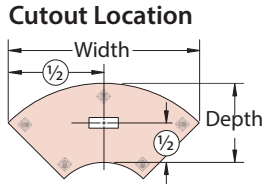

N No Cutout

F Center Power Cutout for 4-Port Single Slided Flip Top Unit

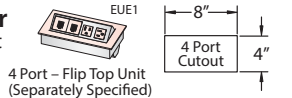

J Center Power Cutout for 6-Port Single Slided Flip Top Unit

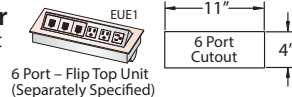

Base & Wire Management Options

Base - No Power

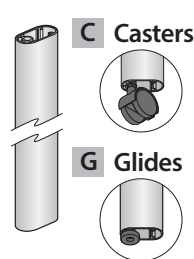

Does not provide access for cord management.

Base - Power Ready

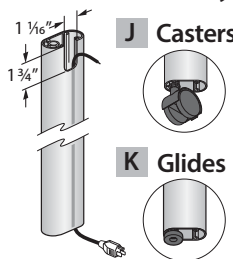

Provides access for cord management through (1) of the Post Extruded Legs. Power ready leg location determined during installation.

- Note**
- The finished height is the same when specified with either Casters or Glides.
 - Casters and Glides are not interchangeable.

Component Materials/Finishes

COMPONENT NAME	MATERIALS/ FINISHES	
Crescent Top Edge Option is applied to all edges.	(L) Laminate – Specify separate top and edge finish colors.	(J) Edgeband
	(W) Wood – Specify a single finish color for top and edge.	(F) Knife
		(K) Edgeband
Post Extruded Base	Extruded Post	Painted Metal – Specify Base Trim Color
	Attachment Plates	Painted Metal – Standard in black
	Base Style	Casters – Standard in black. Glides – Standard in black.

Sizes and Dimensions

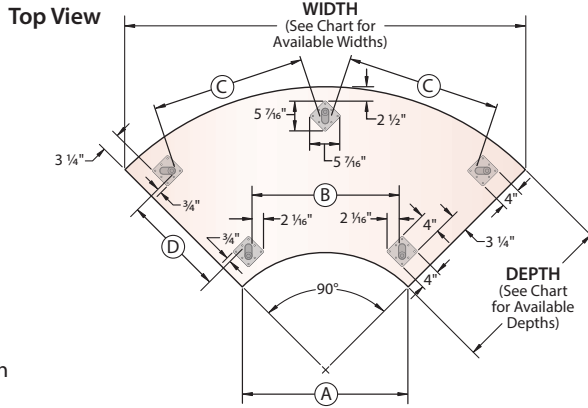

Front View with Glides

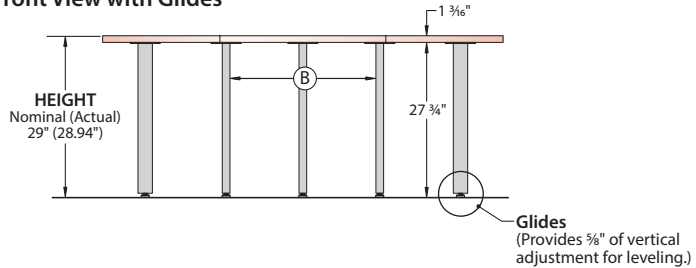

Front View with Casters

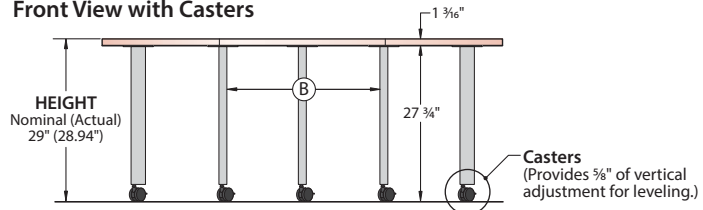

HEIGHT Nominal (Actual)	DEPTH Nominal (Actual)	WIDTH Nominal (Actual)	Number of Columns	Component Dimensions			
				(A)	(B)	(C)	(D)
29" (28.94")	24" (23.68")	60" (59.68")	5	26 3/16"	23 3/4"	20 3/4"	10 7/8"
	30" (29.68")	72" (71.68")	5	29 11/16"	27 3/8"	27 3/4"	16 13/16"
	36" (35.68")	84" (83.68")	5	33 3/16"	31"	34 1/4"	24 3/4"

Table Heights

29" High Tables

- Seated applications.
- Specify with standard height seating (17"-18" seat heights).



Product Details – Jive Tables

Post Extruded Base – Half Racetrack (Top)

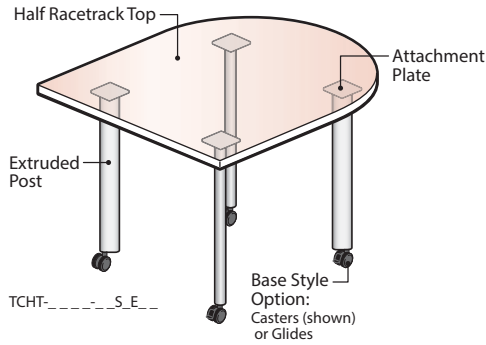

Component Materials/Finishes

COMPONENT NAME		MATERIALS/ FINISHES	
Half Racetrack Top	Edge Option is applied to all edges.	(L) Laminate – Specify separate top and edge finish colors.	(J) Edgeband
		(W) Wood – Specify a single finish color for top and edge.	(F) Knife
			(K) Edgeband
Post Extruded Base	Extruded Post	Painted Metal – Specify Base Trim Color	(U) Knife
	Attachment Plates	Painted Metal – Standard in black	
	Base Style	Casters – Standard in black. Glides – Standard in black.	

Wood Grain Direction

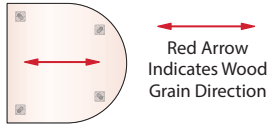

Top Cutout Options

- Power and Data access may be provided by specifying optional factory installed cutouts.
- Cutouts are designed to accommodate separately specified Flip Top Units

Cutout Location

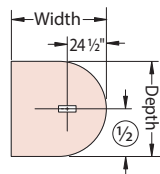

N No Cutout

F Center Power Cutout for 4 Port Single Sided Flip Top Unit

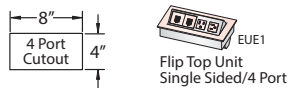

J Center Power Cutout for 6 Port Single Sided Flip Top Unit

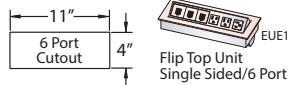

M Center Power Cutout for 8 Port Double Sided Flip Top Unit

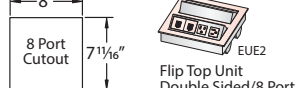

Q Center Power Cutout for 12 Port Double Sided Flip Top Unit

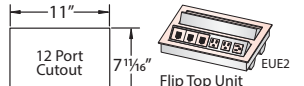

Sizes and Dimensions

Top View with Glides

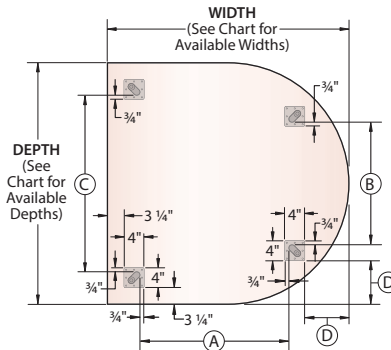

Front View with Glides

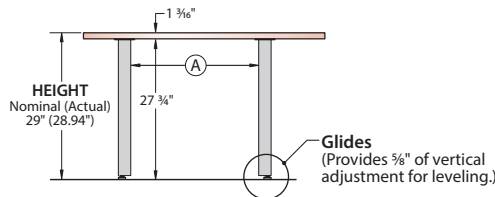

Front View with Casters

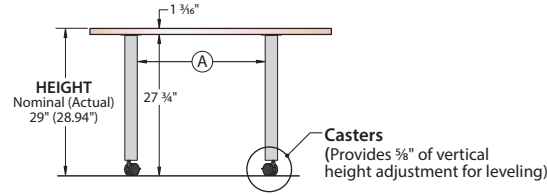

Base & Wire Management Options

Base - No Power

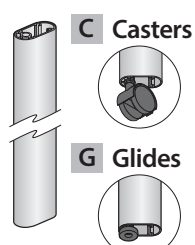

Does not provide access for cord management through the leg.

Base - Power Ready

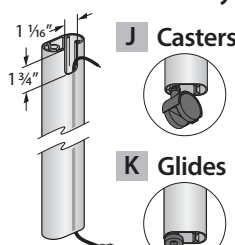

Provides access for cord management through (1) of the Post Extruded Legs. Power ready leg location determined during installation.

- Note**
- The finished height is the same when specified with either Casters or Glides.
 - Casters and Glides are not interchangeable.

HEIGHT Nominal (Actual)	DEPTH Nominal (Actual)	WIDTH Nominal (Actual)	Component Dimensions				Caster/Glide Availability	
			(A)	(B)	(C)	(D)	Casters	Glides
29" (28.94")	42" (41.68")	42" (41.68")	24 3/16"	19 3/16"	28 3/4"	7 13/16"	Yes	Yes
	48" (47.68")	48" (47.68")	29 3/16"	23 7/8"	28 3/4"	8 3/16"	Yes	Yes
	54" (53.68")	54" (53.68")	34 7/16"	28 1/16"	28 3/4"	9 9/16"	Yes	Yes
	60" (59.68")	60" (59.68")	39 3/16"	32 3/16"	28 3/4"	10 7/16"	Yes	Yes

Table Heights

29" High Tables

- Seated height applications.
- Specify with standard height seating (17"-18" seat heights).



Product Details – Jive Tables

Post Extruded Base – Half Pebble (Top)

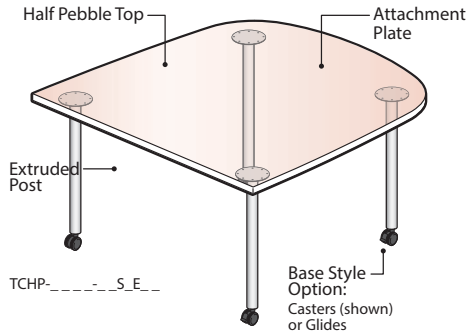

Wood Grain Direction

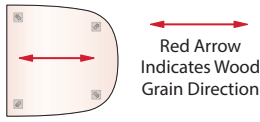

Top Cutout Options

- Power and Data access may be provided by specifying optional factory installed cutouts.
- Cutouts are designed to accommodate separately specified Flip Top Units

Cutout Location

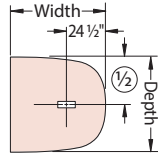

N No Cutout

F Center Power Cutout for 4 Port Single Sided Flip Top Unit

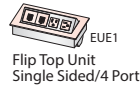
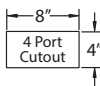

J Center Power Cutout for 6 Port Single Sided Flip Top Unit

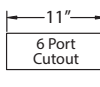

M Center Power Cutout for 8 Port Double Sided Flip Top Unit

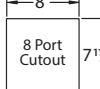

Q Center Power Cutout for 12 Port Double Sided Flip Top Unit

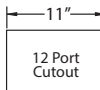

Base & Wire Management Options

Base - No Power

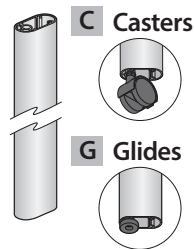

Does not provide access for cord management through the leg.

Base - Power Ready

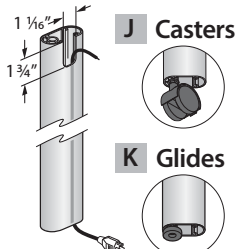

Provides access for cord management through (1) of the Post Extruded Legs. Power ready leg location determined during installation.

- Note**
- The finished height is the same when specified with either Casters or Glides.
 - Casters and Glides are not interchangeable.

Component Materials/Finishes

COMPONENT NAME	MATERIALS/ FINISHES	
Half Pebble Top Edge Option is applied to all edges.	(L) Laminate – Specify separate top and edge finish colors.	(J) Edgeband
	(W) Wood – Specify a single finish color for top and edge.	(F) Knife
		(K) Edgeband (U) Knife
Post Extruded Base	Extruded Post	Painted Metal – Specify Base Trim Color
	Attachment Plates	Painted Metal – Standard in black
	Base Style	Casters – Standard in black. Glides – Standard in black.

Sizes and Dimensions

Top View with Glides

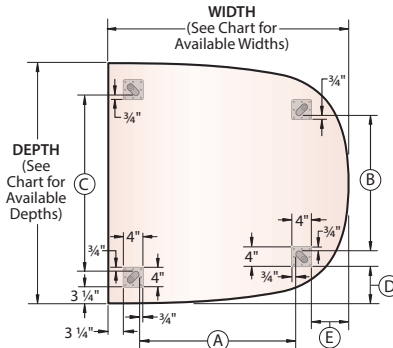

Front View with Glides

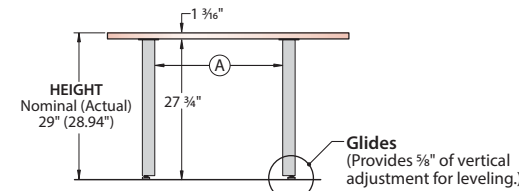

Front View with Casters

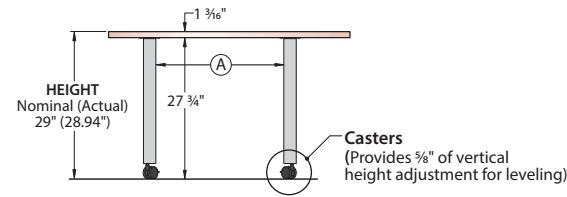

HEIGHT Nominal (Actual)	DEPTH Nominal (Actual)	WIDTH Nominal (Actual)	Component Dimensions					Caster/Glide Availability	
			A	B	C	D	E	Casters	Glides
29" (28.94")	42" (41.68")	42" (41.68")	26 1/8"	20 1/4"	28 11/16"	7 1/2"	5 15/16"	Yes	Yes
	48" (47.68")	48" (47.68")	31"	26 11/16"	34 11/16"	7 1/4"	7"	Yes	Yes
	54" (53.68")	54" (53.68")	35 11/16"	33 1/8"	40 11/16"	7 1/8"	8 5/16"	Yes	Yes
	60" (59.68")	60" (59.68")	39 15/16"	39 3/16"	46 11/16"	6 7/8"	10"	Yes	Yes

Table Heights

29" High Tables

- Seated applications.
- Specify with standard height seating (17"-18" seat heights).

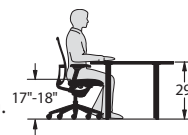

Product Details – Jive Tables

Post Round Base – Round (Top)

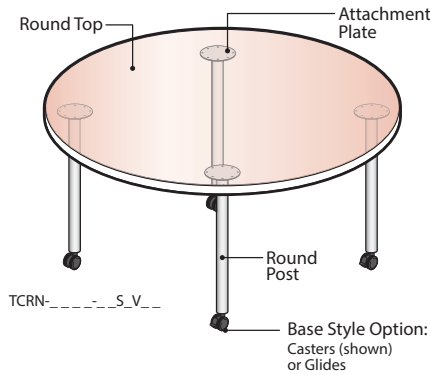

Wood Grain Direction

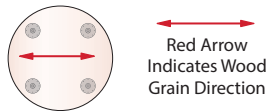

Top Cutout Options

- Power and Data access may be provided by specifying optional factory installed cutouts.
- Cutouts are designed to accommodate separately specified Flip Top Units.

Cutout Location

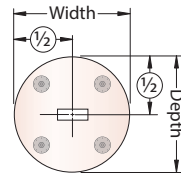

N No Cutout

F Center Power
Cutout for 4-Port Single Sided Flip Top Unit

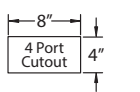

J Center Power
Cutout for 6-Port Single Sided Flip Top Unit

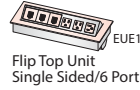
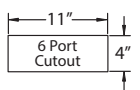

M Center Power
Cutout for 8-Port Double Sided Flip Top Unit

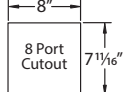

Q Center Power
Cutout for 12-Port Double Sided Flip Top Unit

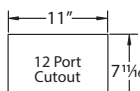

Base & Wire Management Options

Base - No Power

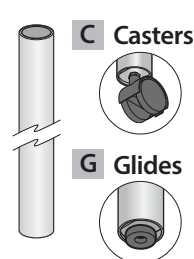

Does not provide access for cord management.

Base - Power Ready

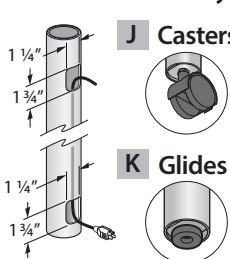

Provides access for cord management through (1) of the Round Column. Power ready leg location determined during installation.

- Note**
- The finished height is the same when specified with either Casters or Glides.
 - Casters and Glides are not Interchangeable.

Component Materials/Finishes

COMPONENT NAME		MATERIALS/ FINISHES	
Round Post	Edge Option is applied to all edges.	(L) Laminate – Specify separate top and edge finish colors.	(J) Edgeband
		(W) Wood – Specify a single finish color for top and edge.	(F) Knife (K) Edgeband (U) Knife
Post Round Base	Round Post and Attachment Plates	Painted Metal – Specify Base Trim Color	
	Base Style	Casters – Standard in black.	
		Glides – Standard in black.	

Sizes and Dimensions

Top View with Glides

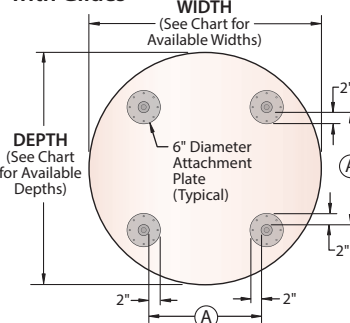

Top View with Casters

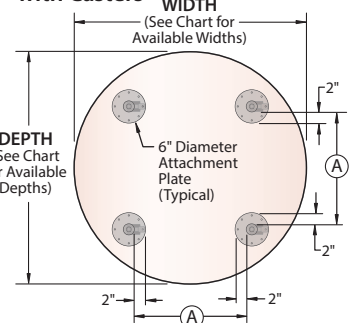

Front View with Glides

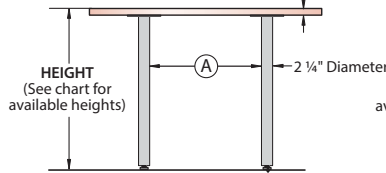

Front View with Casters

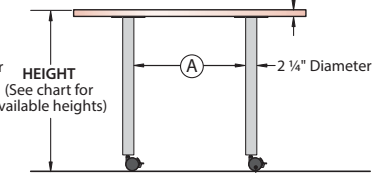

Glides (Provides 3/8" of vertical height adjustment for leveling)

Casters (Provides 3/8" of vertical height adjustment for leveling)

HEIGHT Nominal (Actual)	DEPTH Nominal (Actual)	WIDTH Nominal (Actual)	(A)
16" (15.94")	24" (23.68")	24" (23.68")	7 1/8"
	30" (29.68")	30" (29.68")	11 1/8"
	36" (35.68")	36" (35.68")	15 1/8"
	42" (41.68")	42" (41.68")	19 1/8"
	48" (47.68")	48" (47.68")	24 1/8"
20" (19.94")	24" (23.68")	24" (23.68")	7 1/8"
	30" (29.68")	30" (29.68")	11 1/8"
	36" (35.68")	36" (35.68")	15 1/8"
	42" (41.68")	42" (41.68")	19 1/8"
	48" (47.68")	48" (47.68")	24 1/8"
29" (28.94")	30" (29.68")	30" (29.68")	11 1/8"
	36" (35.68")	36" (35.68")	15 1/8"
	42" (41.68")	42" (41.68")	19 1/8"
	48" (47.68")	48" (47.68")	24 1/8"
	54" (53.68")	54" (53.68")	28 1/8"
60" (59.68")	60" (59.68")	32 1/8"	

Table Heights

29" High Tables

- Seated applications.
- Specify with standard height seating (17"-18" seat heights).

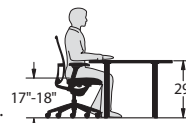

20" High Tables

- Seated/Lounge applications.
- Specify with standard/lounge height seating (14"-18" seat heights).

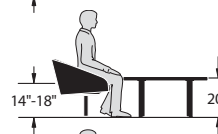

16" High Tables

- Seated/Lounge applications.
- Specify with standard/lounge height seating (14"-18" seat heights).

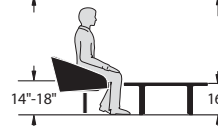

Product Details – Jive Tables

Post Round Base – Square (Top)

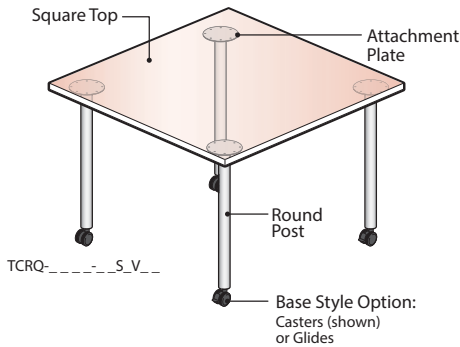

Component Materials/Finishes

COMPONENT NAME		MATERIALS/ FINISHES
Square Top Edge Option is applied to all edges.	(L) Laminate – Specify separate top and edge finish colors.	(J) Edgeband
	(W) Wood – Specify a single finish color for top and edge.	(F) Knife
		(K) Edgeband (U) Knife
Post Round Base	Round Post and Attachment Plates	Painted Metal – Specify Base Trim Color
	Base Style	Casters – Standard in black.
		Glides – Standard in black.

Wood Grain Direction

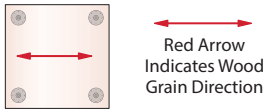

Top Cutout Options

- Power and Data access may be provided by specifying optional factory installed cutouts.
- Cutouts are designed to accommodate separately specified Flip Top Units.

Cutout Location

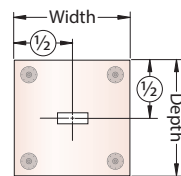

N No Cutout

- F Center Power**
Cutout for 4-Port Single Sided Flip Top Unit

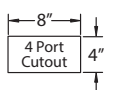

- J Center Power**
Cutout for 6-Port Single Sided Flip Top Unit

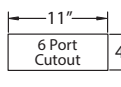

- M Center Power**
Cutout for 8-Port Double Sided Flip Top Unit

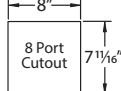

- Q Center Power**
Cutout for 12-Port Double Sided Flip Top Unit

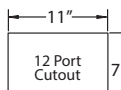

Base & Wire Management Options

Base - No Power

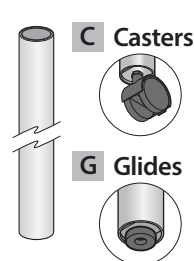

Base - Power Ready

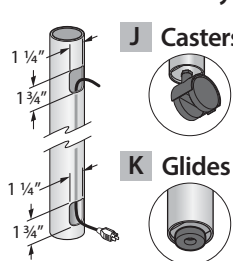

- Note**
- The finished height is the same when specified with either Casters or Glides.
 - Casters and Glides are not Interchangeable.

Sizes and Dimensions

Top View with Glides

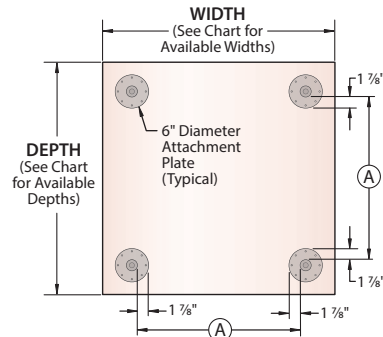

Top View with Casters

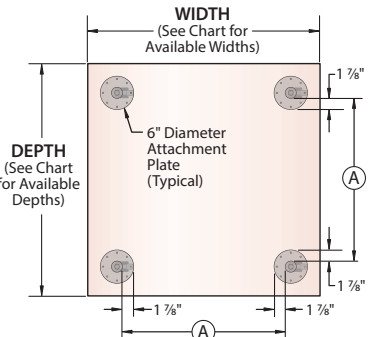

Front View with Glides

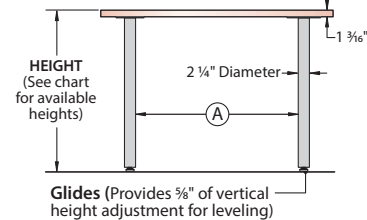

Front View with Casters

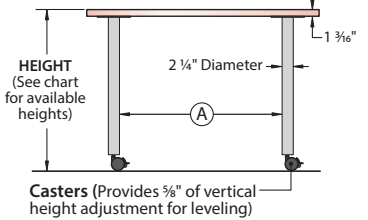

HEIGHT Nominal (Actual)	DEPTH Nominal (Actual)	WIDTH Nominal (Actual)	A
16" (15.94")	24" (23.68")	24" (23.68")	10 15/16"
	30" (29.68")	30" (29.68")	16 15/16"
	36" (35.68")	36" (35.68")	22 15/16"
	42" (41.68")	42" (41.68")	28 15/16"
	48" (47.68")	48" (47.68")	34 15/16"
20" (19.94")	24" (23.68")	24" (23.68")	10 15/16"
	30" (29.68")	30" (29.68")	16 15/16"
	36" (35.68")	36" (35.68")	22 15/16"
	42" (41.68")	42" (41.68")	28 15/16"
	48" (47.68")	48" (47.68")	34 15/16"
29" (28.94")	30" (29.68")	30" (29.68")	16 15/16"
	36" (35.68")	36" (35.68")	22 15/16"
	42" (41.68")	42" (41.68")	28 15/16"
	48" (47.68")	48" (47.68")	34 15/16"
	54" (53.68")	54" (53.68")	40 15/16"
60" (59.68")	60" (59.68")	46 15/16"	

Table Heights

29" High Tables

- Seated applications.
- Specify with standard height seating (17"-18" seat heights).

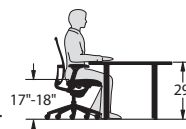

20" High Tables

- Seated/Lounge applications.
- Specify with standard/lounge height seating (14"-18" seat heights).

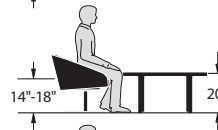

16" High Tables

- Seated/Lounge applications.
- Specify with standard/lounge height seating (14"-18" seat heights).



Product Details – Jive Tables

Post Round Base – Pebble Symmetrical (Top)

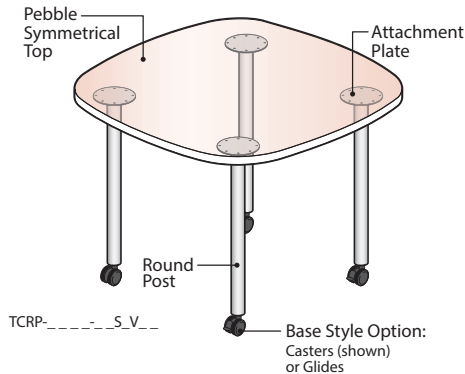

Component Materials/Finishes

COMPONENT NAME		MATERIALS/ FINISHES
Pebble Symmetrical Top Edge Option is applied to all edges.	(L) Laminate – Specify separate top and edge finish colors.	(J) Edgeband
	(W) Wood – Specify a single finish color for top and edge.	(F) Knife
		(K) Edgeband (U) Knife
Post Round Base	Round Post and Attachment Plates	Painted Metal – Specify Base Trim Color
	Base Style	Casters – Standard in black. Glides – Standard in black.

Sizes and Dimensions

Top View with Glides

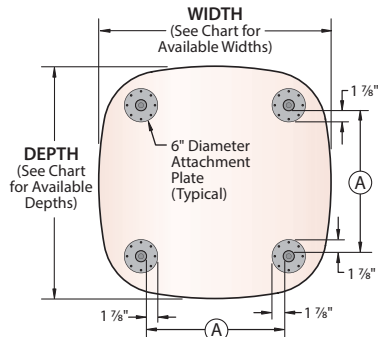

Top View with Casters

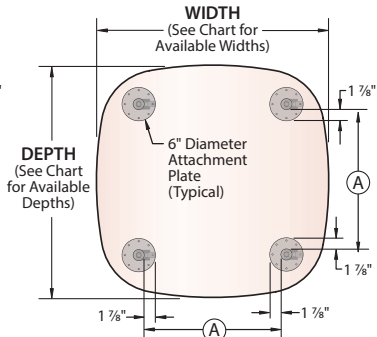

Front View with Glides

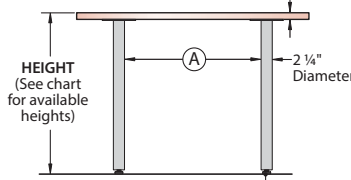

Front View with Casters

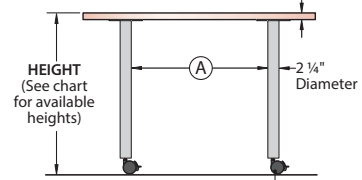

Glides (Provides 3/8" of vertical height adjustment for leveling)

Casters (Provides 3/8" of vertical height adjustment for leveling)

HEIGHT Nominal (Actual)	DEPTH Nominal (Actual)	WIDTH Nominal (Actual)	A
16" (15.94")	24" (23.68")	24" (23.68")	8 3/8"
	30" (29.68")	30" (29.68")	14 1/8"
	36" (35.68")	36" (35.68")	19 3/8"
	42" (41.68")	42" (41.68")	24 1/4"
	48" (47.68")	48" (47.68")	29"
20" (19.94")	24" (23.68")	24" (23.68")	8 3/8"
	30" (29.68")	30" (29.68")	14 1/8"
	36" (35.68")	36" (35.68")	19 3/8"
	42" (41.68")	42" (41.68")	24 1/4"
	48" (47.68")	48" (47.68")	29"
29" (28.94")	30" (29.68")	30" (29.68")	14 1/8"
	36" (35.68")	36" (35.68")	19 3/8"
	42" (41.68")	42" (41.68")	24 1/4"
	48" (47.68")	48" (47.68")	29"
	54" (53.68")	54" (53.68")	33 1/2"
	60" (59.68")	60" (59.68")	37 7/8"

Wood Grain Direction

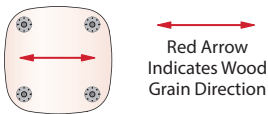

Top Cutout Options

- Power and Data access may be provided by specifying optional factory installed cutouts.
- Cutouts are designed to accommodate separately specified Flip Top Units.

Cutout Location

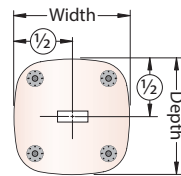

N No Cutout

- F Center Power**
Cutout for 4-Port Single Sided Flip Top Unit

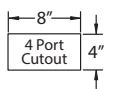

- J Center Power**
Cutout for 6-Port Single Sided Flip Top Unit

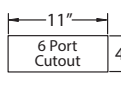

- M Center Power**
Cutout for 8-Port Double Sided Flip Top Unit

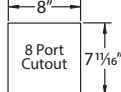

- Q Center Power**
Cutout for 12-Port Double Sided Flip Top Unit

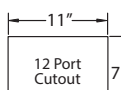

Base & Wire Management Options

Base - No Power

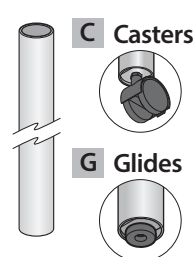

Does not provide access for cord management.

Base - Power Ready

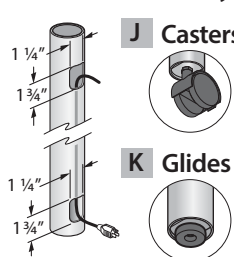

Provides access for cord management through (1) of the Round Column. Power ready leg location determined during installation.

- Note**
- The finished height is the same when specified with either Casters or Glides.
 - Casters and Glides are not interchangeable.

Table Heights

29" High Tables

- Seated applications.
- Specify with standard height seating (17"-18" seat heights).



20" High Tables

- Seated/Lounge applications.
- Specify with standard/lounge height seating (14"-18" seat heights).

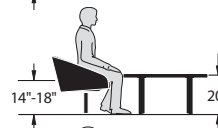

16" High Tables

- Seated/Lounge applications.
- Specify with standard/lounge height seating (14"-18" seat heights).

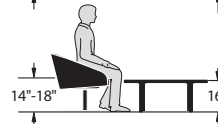

Product Details – Jive Tables

Post Round Base – Pebble Asymmetrical (Top)

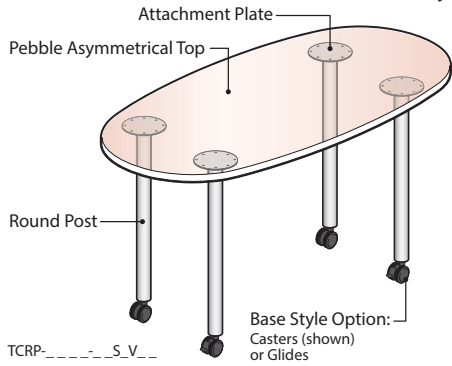

Component Materials/Finishes

COMPONENT NAME		MATERIALS/ FINISHES
Pebble Asymmetrical Top	Edge Option is applied to all edges.	(L) Laminate – Specify separate top and edge finish colors.
		(W) Wood – Specify a single finish color for top and edge.
		(U) Knife
Post Round Base	Round Post and Attachment Plates	Painted Metal – Specify Base Trim Color
	Base Style	Casters – Standard in black. Glides – Standard in black.

Wood Grain Direction

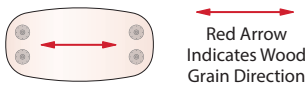

Top Cutout Options

- Power and Data access may be provided by specifying optional factory installed cutouts.
- Cutouts are designed to accommodate separately specified Flip Top Units.

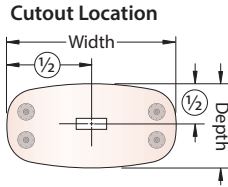

N No Cutout

F Center Power

Cutout for 4-Port Single Sided Flip Top Unit

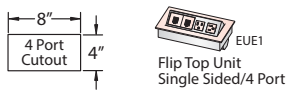

J Center Power

Cutout for 6-Port Single Sided Flip Top Unit

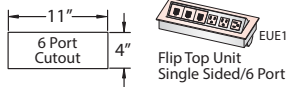

M Center Power

Cutout for 8-Port Double Sided Flip Top Unit

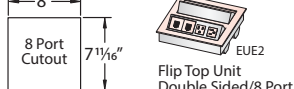

Q Center Power

Cutout for 12-Port Double Sided Flip Top Unit

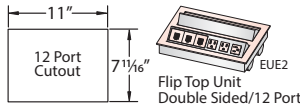

Sizes and Dimensions

Top View with Glides

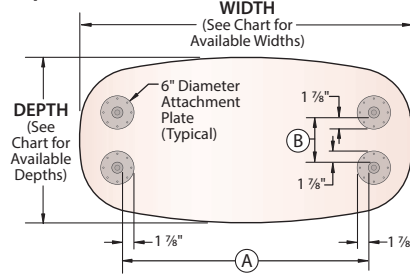

Front View with Glides

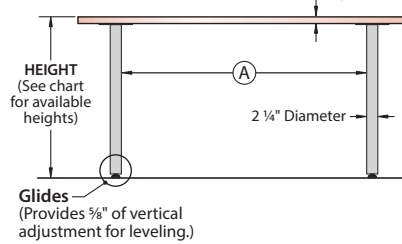

Front View with Casters

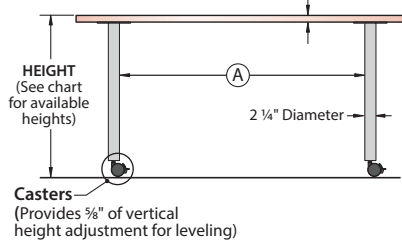

HEIGHT Nominal (Actual)	DEPTH Nominal (Actual)	WIDTH Nominal (Actual)	(A)	(B)
16" (15.94")	30" (29.68")	48" (47.68")	32"	8"
		60" (59.68")	43 3/8"	7 7/8"
		72" (71.68")	55 3/4"	7 9/16"
	36" (35.68")	60" (59.68")	42 3/8"	14 1/2"
		72" (71.68")	54 3/4"	14 3/8"
		84" (83.68")	66 3/4"	14 3/8"
20" (19.94")	30" (29.68")	48" (47.68")	32"	8"
		60" (59.68")	43 3/8"	7 7/8"
		72" (71.68")	55 3/4"	7 9/16"
	36" (35.68")	60" (59.68")	42 3/8"	14 1/2"
		72" (71.68")	54 3/4"	14 3/8"
		84" (83.68")	66 3/4"	14 3/8"
29" (28.94")	30" (29.68")	48" (47.68")	32"	8"
		60" (59.68")	43 3/8"	7 7/8"
		72" (71.68")	55 3/4"	7 9/16"
	36" (35.68")	60" (59.68")	42 3/8"	14 1/2"
		72" (71.68")	54 3/4"	14 3/8"
		84" (83.68")	66 3/4"	14 3/8"

Base & Wire Management Options

Base - No Power

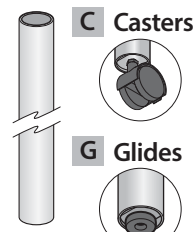

Does not provide access for cord management.

Base - Power Ready

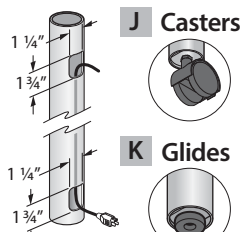

Provides access for cord management through (1) of the Round Column. Power ready leg location determined during installation.

- Note**
- The finished height is the same when specified with either Casters or Glides.
 - Casters and Glides are not interchangeable.

Table Heights

29" High Tables

- Seated applications.
- Specify with standard height seating (17"-18" seat heights).



20" High Tables

- Seated/Lounge applications.
- Specify with standard/lounge height seating (14"-18" seat heights).

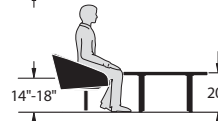

16" High Tables

- Seated/Lounge applications.
- Specify with standard/lounge height seating (14"-18" seat heights).

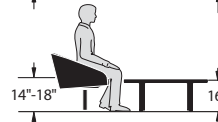

Product Details – Jive Tables

Post Round Base – Rectangle (Top)

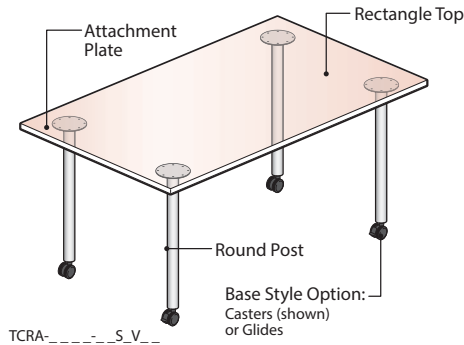

Wood Grain Direction

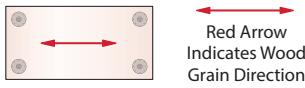

Top Cutout Options

- Power and Data access may be provided by specifying optional factory installed cutouts.
- Cutouts are designed to accommodate separately specified Flip Top Units.

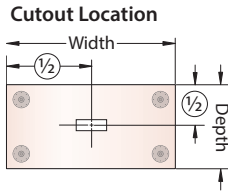

N No Cutout

- #### F Center Power
- Cutout for 4-Port Single Sided Flip Top Unit

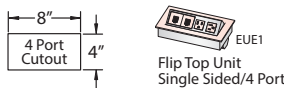

- #### J Center Power
- Cutout for 6-Port Single Sided Flip Top Unit

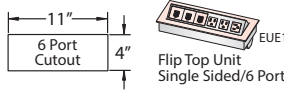

- #### M Center Power
- Cutout for 8-Port Double Sided Flip Top Unit

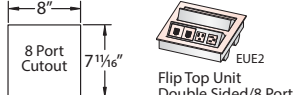

- #### Q Center Power
- Cutout for 12-Port Double Sided Flip Top Unit

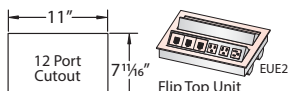

Base & Wire Management Options

Base - No Power

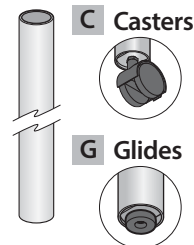

Does not provide access for cord management.

Base - Power Ready

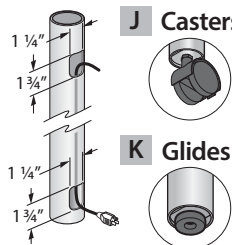

Provides access for cord management through (1) of the Round Column. Power ready leg location determined during installation.

- Note**
- The finished height is the same when specified with either Casters or Glides.
 - Casters and Glides are not interchangeable.

Component Materials/Finishes

COMPONENT NAME		MATERIALS/ FINISHES	
Rectangle Top	Edge Option is applied to all edges.	(L) Laminate – Specify separate top and edge finish colors.	(J) Edgeband
		(W) Wood – Specify a single finish color for top and edge.	(F) Knife (K) Edgeband (U) Knife
Post Round Base	Round Post and Attachment Plates	Painted Metal – Specify Base Trim Color	
	Base Style	Casters – Standard in black. Glides – Standard in black.	

Sizes and Dimensions

Top View with Glides

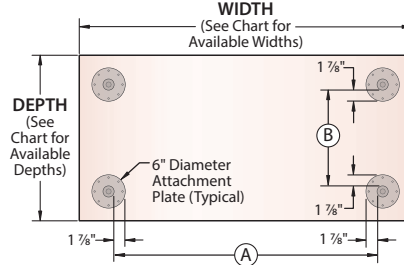

Front View with Glides

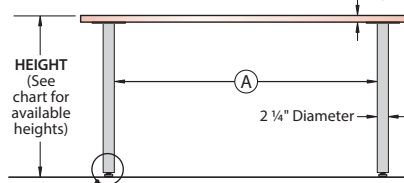

Glides (Provides 3/8" of vertical adjustment for leveling.)

Front View with Casters

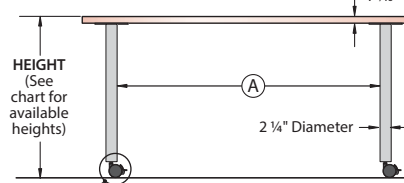

Casters (Provides 3/8" of vertical height adjustment for leveling)

HEIGHT Nominal (Actual)	DEPTH Nominal (Actual)	WIDTH Nominal (Actual)	A	B
16" (15.94")	30" (29.68")	48" (47.68")	34 1/8"	16 1/8"
		54" (53.68")	40 1/8"	16 1/8"
	36" (35.68")	60" (59.68")	46 1/8"	16 1/8"
		72" (71.68")	58 1/8"	22 1/8"
20" (19.94")	30" (29.68")	48" (47.68")	34 1/8"	16 1/8"
		54" (53.68")	40 1/8"	16 1/8"
	36" (35.68")	60" (59.68")	46 1/8"	16 1/8"
		72" (71.68")	58 1/8"	22 1/8"
18" (17.68")	36" (35.68")	48" (47.68")	34 1/8"	4 1/8"
		54" (53.68")	40 1/8"	4 1/8"
	42" (41.68")	60" (59.68")	46 1/8"	4 1/8"
		72" (71.68")	58 1/8"	10 1/8"
24" (23.68")	36" (35.68")	42" (41.68")	28 1/8"	10 1/8"
		48" (47.68")	35 3/8"	10 1/8"
	42" (41.68")	54" (53.68")	40 1/8"	10 1/8"
		60" (59.68")	46 1/8"	10 1/8"
29" (28.94")	36" (35.68")	66" (65.68")	52 1/8"	10 1/8"
		72" (71.68")	58 1/8"	10 1/8"
	42" (41.68")	48" (47.68")	34 1/8"	16 1/8"
		54" (53.68")	40 1/8"	16 1/8"
30" (29.68")	42" (41.68")	60" (59.68")	46 1/8"	16 1/8"
		72" (71.68")	58 1/8"	16 1/8"
	48" (47.68")	60" (59.68")	46 1/8"	22 1/8"
		72" (71.68")	58 1/8"	22 1/8"
36" (35.68")	48" (47.68")	66" (65.68")	52 1/8"	22 1/8"
		72" (71.68")	58 1/8"	22 1/8"
	60" (59.68")	60" (59.68")	46 1/8"	28 1/8"
		72" (71.68")	58 1/8"	28 1/8"
42" (41.68")	60" (59.68")	66" (65.68")	52 1/8"	28 1/8"
		72" (71.68")	58 1/8"	28 1/8"
	72" (71.68")	60" (59.68")	46 1/8"	28 1/8"
		72" (71.68")	58 1/8"	28 1/8"
48" (47.68")	72" (71.68")	58 1/8"	34 1/8"	

Table Heights

29" High Tables

- Seated applications.
- Specify with standard height seating (17"-18" seat heights).

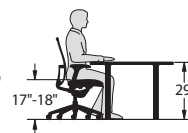

20" High Tables

- Seated/Lounge applications.
- Specify with standard/lounge height seating (14"-18" seat heights).

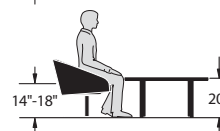

16" High Tables

- Seated/Lounge applications.
- Specify with standard/lounge height seating (14"-18" seat heights).

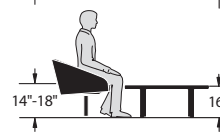

Product Details – Jive Tables

Post Round Base – Racetrack (Top)

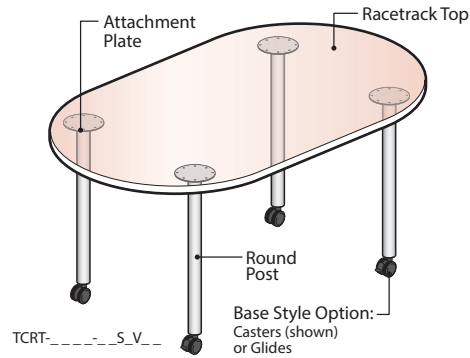

Wood Grain Direction

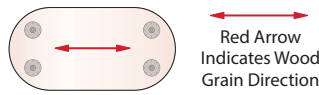

Top Cutout Options

- Power and Data access may be provided by specifying optional factory installed cutouts.
- Cutouts are designed to accommodate separately specified Flip Top Units.

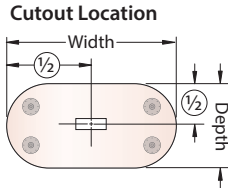

N No Cutout

F Center Power

Cutout for 4-Port Single Sided Flip Top Unit

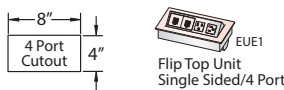

J Center Power

Cutout for 6-Port Single Sided Flip Top Unit

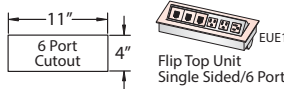

M Center Power

Cutout for 8-Port Double Sided Flip Top Unit

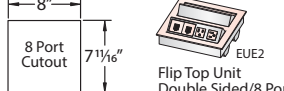

Q Center Power

Cutout for 12-Port Double Sided Flip Top Unit

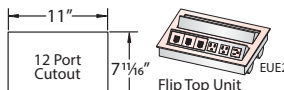

Base & Wire Management Options

Base - No Power

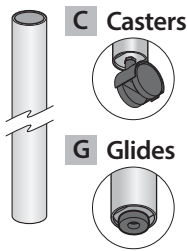

Does not provide access for cord management.

Base - Power Ready

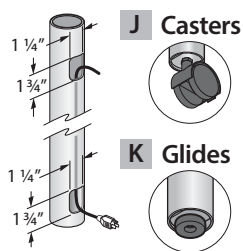

Provides access for cord management through (1) of the Round Column. Power ready leg location determined during installation.

- Note**
- The finished height is the same when specified with either Casters or Glides.
 - Casters and Glides are not interchangeable.

Component Materials/Finishes

COMPONENT NAME		MATERIALS/ FINISHES	
Rectangle Top Edge Option is applied to all edges.	(L) Laminate – Specify separate top and edge finish colors.	(J) Edgeband	(F) Knife
	(W) Wood – Specify a single finish color for top and edge.	(K) Edgeband	(U) Knife
Post Round Base	Round Post and Attachment Plates	Painted Metal – Specify Base Trim Color	
	Base Style	Casters – Standard in black. Glides – Standard in black.	

Sizes and Dimensions

Top View with Glides

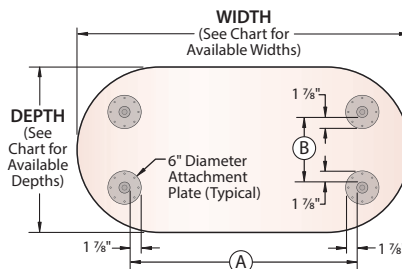

Front View with Glides

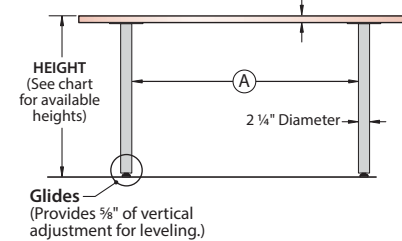

Front View with Casters

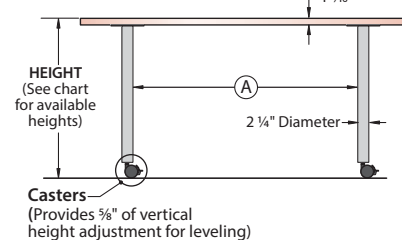

HEIGHT Nominal (Actual)	DEPTH Nominal (Actual)	WIDTH Nominal (Actual)	A	B
16" (15.94")	30" (29.68")	48" (47.68")	29 5/16"	11 5/16"
		60" (59.68")	41 5/16"	11 5/16"
	36" (35.68")	60" (59.68")	39 5/16"	15 5/16"
		72" (71.68")	51 5/16"	15 5/16"
20" (19.94")	30" (29.68")	48" (47.68")	29 5/16"	11 5/16"
		60" (59.68")	41 5/16"	11 5/16"
	36" (35.68")	60" (59.68")	39 5/16"	15 5/16"
		72" (71.68")	51 5/16"	15 5/16"
29" (28.94")	30" (29.68")	48" (47.68")	29 5/16"	11 5/16"
		60" (59.68")	41 5/16"	11 5/16"
	36" (35.68")	60" (59.68")	39 5/16"	15 5/16"
		72" (71.68")	51 5/16"	15 5/16"
42" (41.68")	72" (71.68")	49 13/16"	19 13/16"	
	48" (47.68")	72" (71.68")	48 1/16"	24 1/16"

Table Heights

29" High Tables

- Seated applications.
- Specify with standard height seating (17"-18" seat heights).

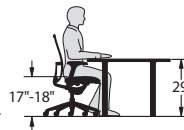

20" High Tables

- Seated/Lounge applications.
- Specify with standard/lounge height seating (14"-18" seat heights).

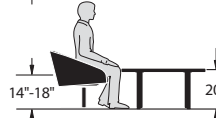

16" High Tables

- Seated/Lounge applications.
- Specify with standard/lounge height seating (14"-18" seat heights).

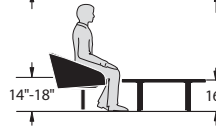

Product Details – Jive Tables

Post Round Base – Trapezoid (Top)

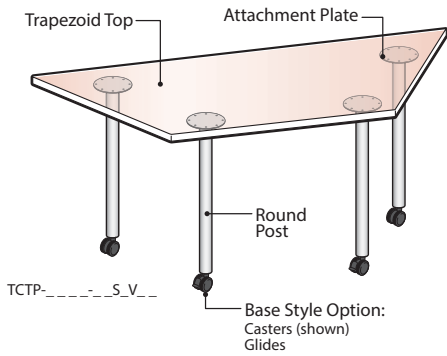

Component Materials/Finishes

COMPONENT NAME		MATERIALS/ FINISHES
Trapezoid Top	Edge Option is applied to all edges.	(L) Laminate – Specify separate top and edge finish colors.
		(W) Wood – Specify a single finish color for top and edge.
Post Round Base	Round Post and Attachment Plates	Painted Metal – Specify Base Trim Color
	Base Style	Casters – Standard in black.
		Glides – Standard in black.

Sizes and Dimensions

Top View with Glides

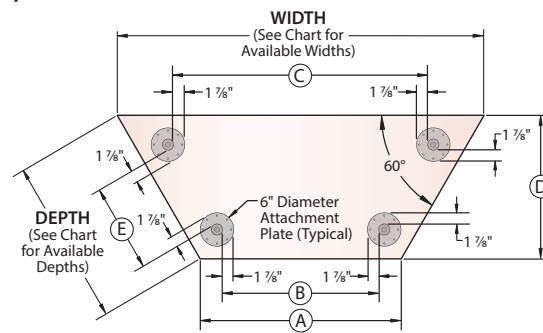

Front View with Glides

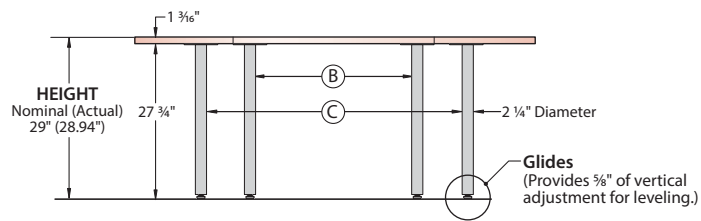

Front View with Casters

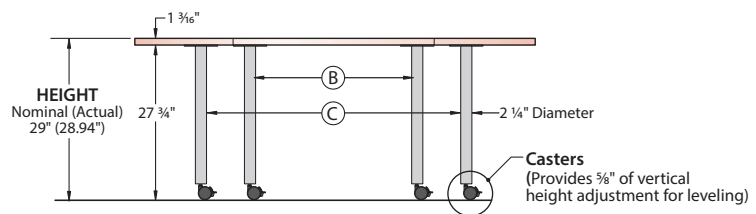

Wood Grain Direction

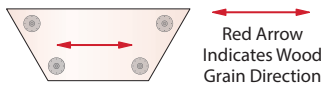

Top Cutout Options

- Power and Data access may be provided by specifying optional factory installed cutouts.
- Cutouts are designed to accommodate separately specified Flip Top Units.

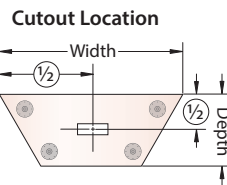

N No Cutout

F Center Power

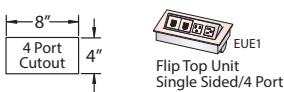

J Center Power

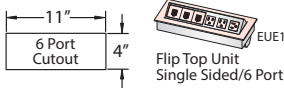

Base & Wire Management Options

Base - No Power

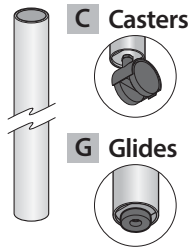

Does not provide access for cord management.

Base - Power Ready

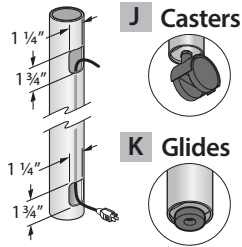

Provides access for cord management through (1) of the Round Column. Power ready leg location determined during installation.

Table Heights

29" High Tables

- Seated applications.
- Specify with standard height seating (17"-18" seat heights).

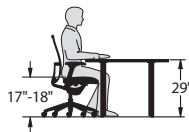

Note

- The finished height is the same when specified with either Casters or Glides.
- Casters and Glides are not Interchangeable.

HEIGHT Nominal (Actual)	DEPTH Nominal (Actual)	WIDTH Nominal (Actual)	Component Dimensions				
			(A)	(B)	(C)	(D)	(E)
29" (28.94")	24" (23.68")	48" (47.68")	24.0"	15 1/16"	27 1/4"	20 1/2"	9 9/16"
		54" (53.68")	30.0"	21 1/16"	33 1/4"	20 1/2"	9 9/16"
		60" (59.68")	36.0"	27 1/16"	39 1/4"	20 1/2"	9 9/16"
		66" (65.68")	42.0"	33 1/16"	45 1/4"	20 1/2"	9 9/16"
		72" (71.68")	48.0"	39 1/16"	51 1/4"	20 1/2"	9 9/16"
30" (29.68")	24" (23.68")	60" (59.68")	30.0"	21 1/16"	39 1/4"	25 1/16"	15 5/16"
		66" (65.68")	36.0"	27 1/16"	45 1/4"	25 1/16"	15 5/16"
		72" (71.68")	42.0"	33 1/16"	51 1/4"	25 1/16"	15 5/16"
36" (35.68")	24" (23.68")	84" (59.68")	48.0"	39 1/16"	63 1/4"	30 7/8"	21 3/16"

Product Details – Jive Tables

Post Round Base – Crescent (Top)

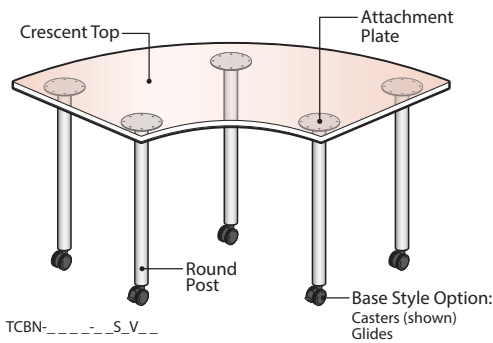

Wood Grain Direction

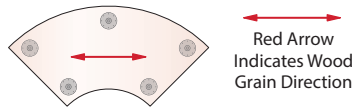

Top Cutout Options

- Power and Data access may be provided by specifying optional factory installed cutouts.
- Cutouts are designed to accommodate separately specified Flip Top Units.

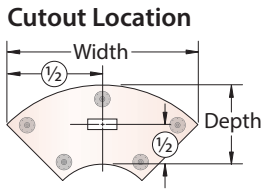

N No Cutout

F Center Power Cutout for 4-Port Single Sided Flip Top Unit

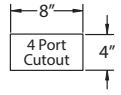

J Center Power Cutout for 6-Port Single Sided Flip Top Unit

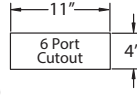

Table Heights

29" High Tables

- Seated applications.
- Specify with standard height seating (17"-18" seat heights).



Base & Wire Management Options

Base - No Power

Base - Power Ready

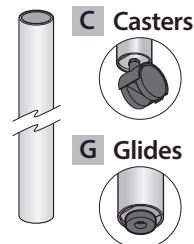

Does not provide access for cord management.

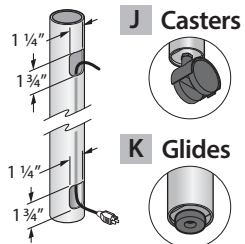

Provides access for cord management through (1) of the Round Column. Power ready leg location determined during installation.

- Note**
- The finished height is the same when specified with either Casters or Glides.
 - Casters and Glides are not Interchangeable.

Component Materials/Finishes

COMPONENT NAME		MATERIALS/ FINISHES	
Crescent Top	Edge Option is applied to all edges.	(L) Laminate – Specify separate top and edge finish colors.	(J) Edgeband
		(W) Wood – Specify a single finish color for top and edge.	(F) Knife (K) Edgeband (U) Knife
Post Round Base	Round Post and Attachment Plates	Painted Metal – Specify Base Trim Color	
	Base Style	Casters – Standard in black. Glides – Standard in black.	

Sizes and Dimensions

Top View

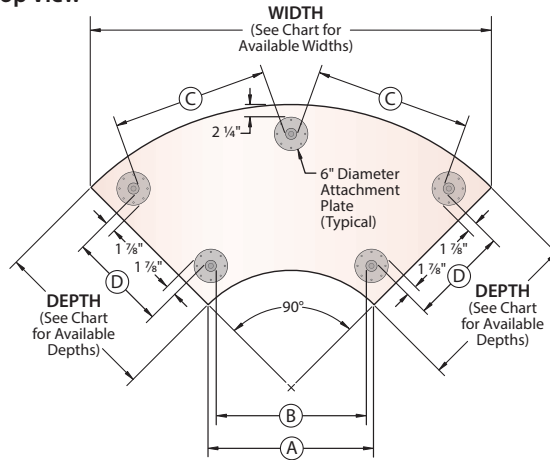

Front View with Glides

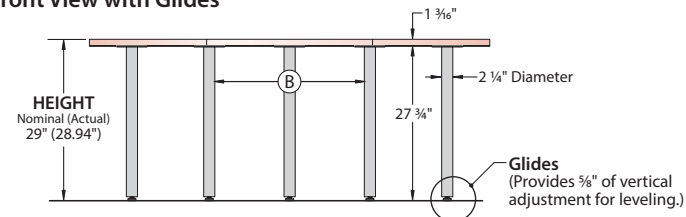

Front View with Casters

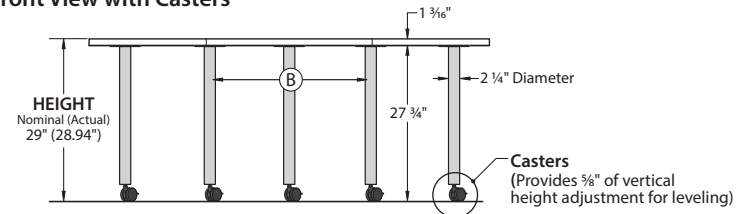

HEIGHT Nominal (Actual)	DEPTH Nominal (Actual)	WIDTH Nominal (Actual)	Number of Columns	Component Dimensions			
				A	B	C	D
29" (28.94")	24" (23.68")	60" (59.68")	5	26 3/16"	22 7/8"	21 1/8"	11 3/16"
	30" (29.68")	72" (71.68")	5	29 11/16"	25 11/16"	27 3/8"	17 3/16"
	36" (35.68")	84" (83.68")	5	33 3/16"	29 3/16"	34 1/8"	23 3/16"

Product Details – Jive Tables

Post Round Base – Half Racetrack (Top)

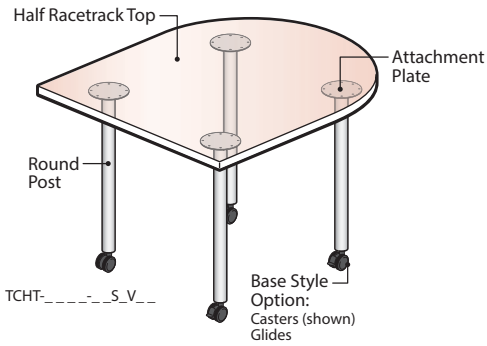

Component Materials/Finishes

COMPONENT NAME		MATERIALS/ FINISHES	
Half Racetrack Top Edge Option is applied to all edges.	(L) Laminate – Specify separate top and edge finish colors.	(J) Edgeband	(F) Knife
	(W) Wood – Specify a single finish color for top and edge.	(K) Edgeband	(U) Knife
Post Extruded Base	Round Post and Attachment Plates	Painted Metal – Specify Base Trim Color	
	Base Style	Casters – Standard in black. Glides – Standard in black.	

Wood Grain Direction

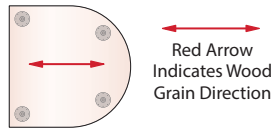

Top Cutout Options

- Power and Data access may be provided by specifying optional factory installed cutouts.
- Cutouts are designed to accommodate separately specified Flip Top Units

Cutout Location

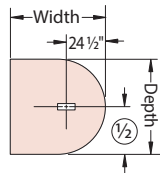

N No Cutout

F Center Power Cutout for 4 Port Single Sided Flip Top Unit

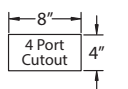

J Center Power Cutout for 6 Port Single Sided Flip Top Unit

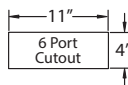

M Center Power Cutout for 8 Port Double Sided Flip Top Unit

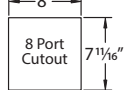

Q Center Power Cutout for 12 Port Double Sided Flip Top Unit

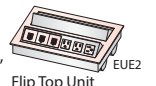
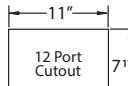

Sizes and Dimensions

Top View with Glides

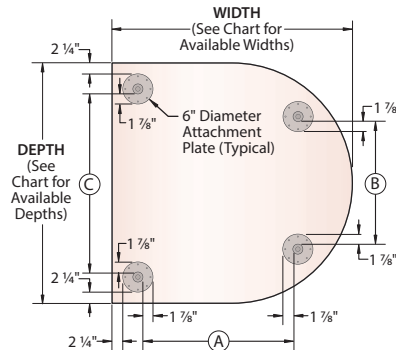

Front View with Glides

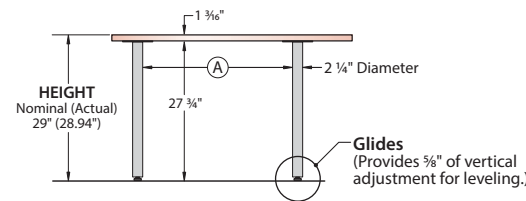

Front View with Casters

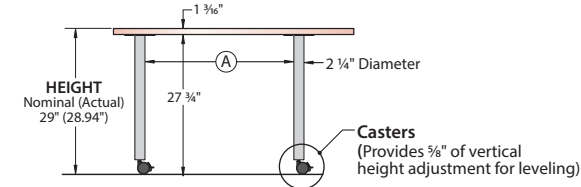

Base & Wire Management Options

Base - No Power

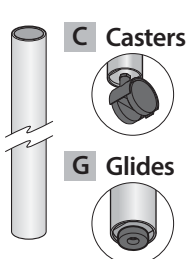

Does not provide access for cord management.

Base - Power Ready

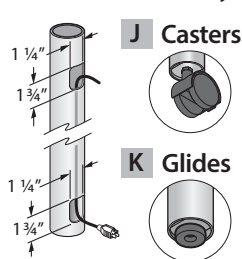

Provides access for cord management through (1) of the Round Column. Power ready leg location determined during installation.

Note

- The finished height is the same when specified with either Casters or Glides.
- Casters and Glides are not Interchangeable.

HEIGHT Nominal (Actual)	DEPTH Nominal (Actual)	WIDTH Nominal (Actual)	Component Dimensions			Caster/Glide Availability	
			A	B	C	Casters	Glides
29" (28.94")	42" (41.68")	42" (41.68")	24 3/8"	19 13/16"	28 19/16"	Yes	Yes
	48" (47.68")	48" (47.68")	29 1/2"	24 1/8"	34 15/16"	Yes	Yes
	54" (53.68")	54" (53.68")	34 5/8"	28 3/8"	40 19/16"	Yes	Yes
	60" (59.68")	60" (59.68")	39 3/4"	32 3/8"	46 15/16"	Yes	Yes

Table Heights

29" High Tables

- Seated height applications.
- Specify with standard height seating (17"-18" seat heights).

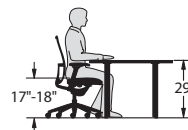

Product Details – Jive Tables

Post Extruded Base – Half Pebble (Top)

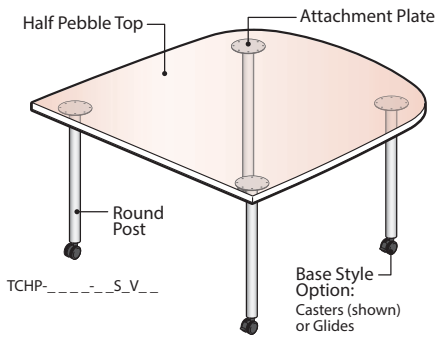

Component Materials/Finishes

COMPONENT NAME		MATERIALS/ FINISHES
Half Pebble Top	Edge Option is applied to all edges.	(L) Laminate – Specify separate top and edge finish colors.
		(W) Wood – Specify a single finish color for top and edge.
		(J) Edgeband (F) Knife (K) Edgeband (U) Knife
Post Extruded Base	Round Post and Attachment Plates	Painted Metal – Specify Base Trim Color
	Base Style	Casters – Standard in black. Glides – Standard in black.

Wood Grain Direction

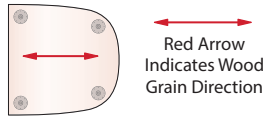

Top Cutout Options

- Power and Data access may be provided by specifying optional factory installed cutouts.
- Cutouts are designed to accommodate separately specified Flip Top Units

Cutout Location

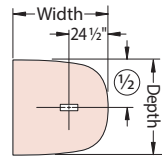

N No Cutout

F Center Power

Cutout for 4 Port Single Sided Flip Top Unit

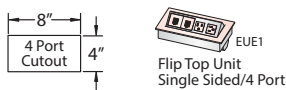

J Center Power

Cutout for 6 Port Single Sided Flip Top Unit

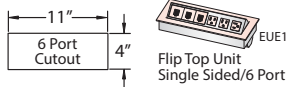

M Center Power

Cutout for 8 Port Double Sided Flip Top Unit

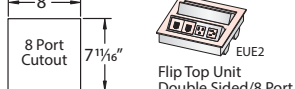

Q Center Power

Cutout for 12 Port Double Sided Flip Top Unit

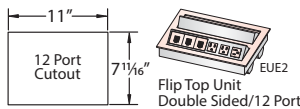

Sizes and Dimensions

Top View with Glides

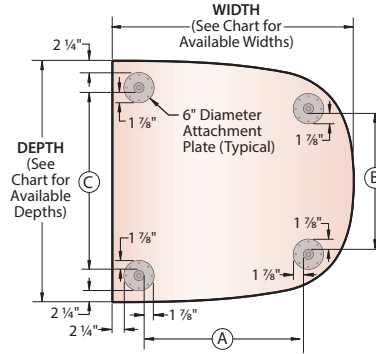

Front View with Glides

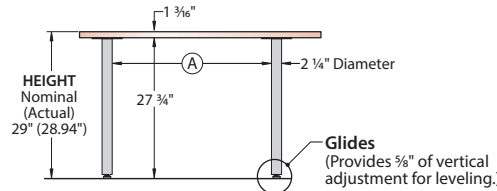

Front View with Casters

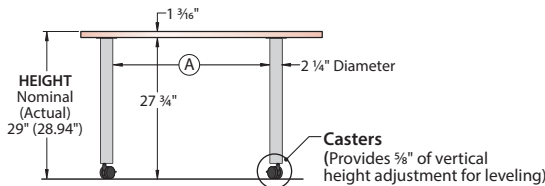

Base & Wire Management Options

Base - No Power

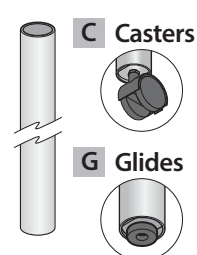

Does not provide access for cord management.

Base - Power Ready

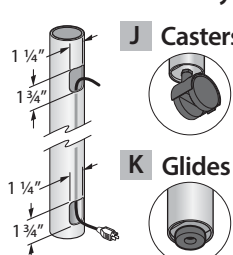

Provides access for cord management through (1) of the Round Column. Power ready leg location determined during installation.

- Note**
- The finished height is the same when specified with either Casters or Glides.
 - Casters and Glides are not Interchangeable.

HEIGHT Nominal (Actual)	DEPTH Nominal (Actual)	WIDTH Nominal (Actual)	Component Dimensions			Caster/Glide Availability	
			(A)	(B)	(C)	Casters	Glides
29" (28.94")	42" (41.68")	42" (41.68")	26 1/4"	20 1/2"	28 15/16"	Yes	Yes
	48" (47.68")	48" (47.68")	31 1/4"	26 15/16"	34 15/16"	Yes	Yes
	54" (53.68")	54" (53.68")	35 7/8"	33 3/8"	40 15/16"	Yes	Yes
	60" (59.68")	60" (59.68")	40 3/16"	39 3/4"	46 15/16"	Yes	Yes

Table Heights

29" High Tables

- Seated applications.
- Specify with standard height seating (17"-18" seat heights).

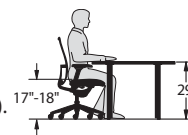

Product Details – Jive Tables

X-Base – Round (Top)

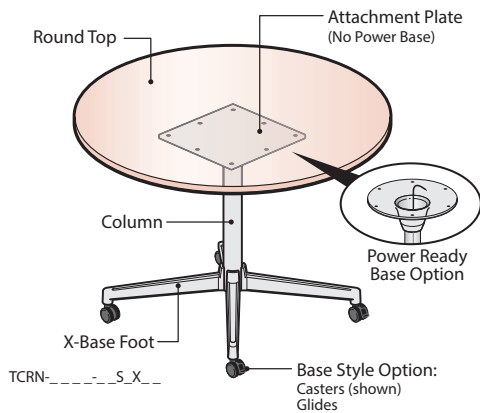

Wood Grain Direction

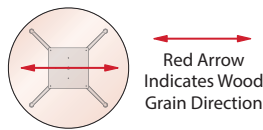

Top Cutout Options

- Power and Data access may be provided by specifying an optional factory installed cutout.
- Cutouts are designed to accommodate separately specified Grommets or Power/Data Dome.

Cutout Location

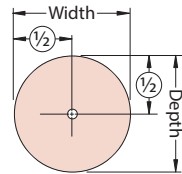

N No Cutout

- R 3" Cutout** (With Power Ready Base Option only)



Base & Wire Management Options

Base - No Power
Does not provide access for cord management.

Base - Power Ready
Provides access for cord management through the top to the bottom of the column.

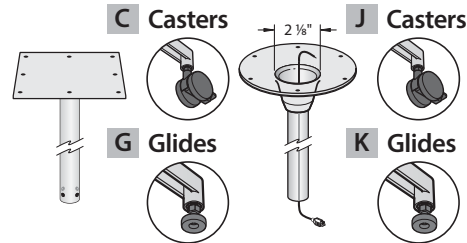

Component Materials/Finishes

COMPONENT NAME		MATERIALS/ FINISHES	
Round Top	Edge Option is applied to all edges.	(L) Laminate – Specify separate top and edge finish colors.	(J) Edgeband
		(W) Wood – Specify a single finish color for top and edge.	(F) Knife (K) Edgeband (U) Knife
X Base	Foot, Column and Attachment Plate	(A) Painted – The Foot, Column and Attachment Plate are painted metal, specify base trim color.	
		(B) Polished – The Foot is polished aluminum. The Column and Attachment Plate are painted metal, specify base trim color.	
	Base Style	Casters – Standard in black.	
		Glides – Standard in black.	

Sizes and Dimensions

Top View – No Power with Casters

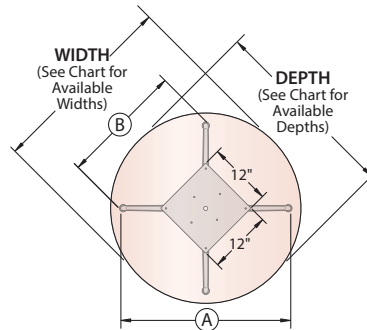

Top View – Power Ready with Glides

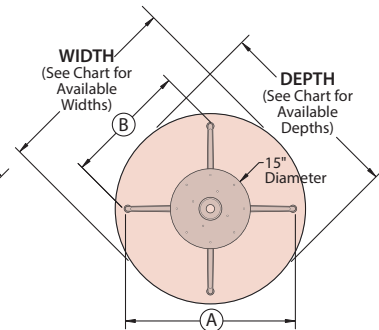

Front View – No Power with Casters

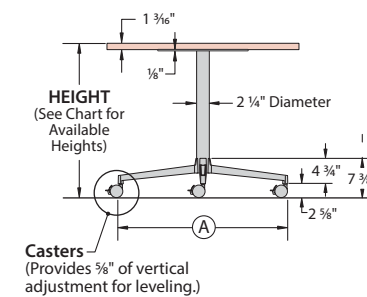

Front View – Power Ready with Glides

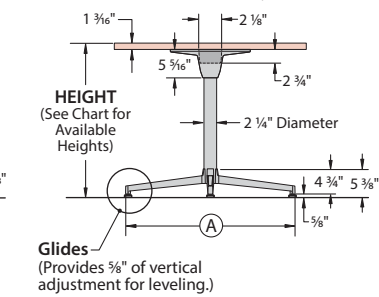
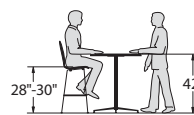

Table Heights

42" High Tables

- Seated or standing applications.
- Specify with bar height stools (28"-30" seat heights).



36" High Tables

- Seated or standing applications.
- Specify with counter height stools (24"-26" seat heights).

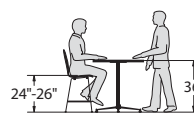

29" High Tables

- Seated applications.
- Specify with standard height seating (17"-18" seat heights).



20" High Tables

- Seated or lounge applications.
- Specify with standard or lounge height seating (14"-18" seat heights).

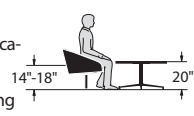

16" High Tables

- Seated or lounge applications.
- Specify with standard or lounge height seating (14"-18" seat heights).

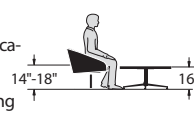

HEIGHT Nominal (Actual)	WIDTH/ DEPTH Nominal (Actual)	A	B
16" (15.94")	24" (23.68")	22 7/8"	16 7/16"
	30" (29.68")	28 7/8"	20 11/16"
	36" (35.68")	31 7/8"	22 13/16"
	42" (41.68")	37 7/8"	27 1/16"
20" (19.94")	24" (23.68")	22 7/8"	16 7/16"
	30" (29.68")	28 7/8"	20 11/16"
	36" (35.68")	31 7/8"	22 13/16"
	42" (41.68")	37 7/8"	27 1/16"
29" (28.94")	24" (23.68")	22 7/8"	16 7/16"
	30" (29.68")	28 7/8"	20 11/16"
	36" (35.68")	31 7/8"	22 13/16"
	42" (41.68")	37 7/8"	27 1/16"
36" (35.94")	24" (23.68")	22 7/8"	16 7/16"
	30" (29.68")	28 7/8"	20 11/16"
	36" (35.68")	31 7/8"	22 13/16"
	42" (41.68")	37 7/8"	27 1/16"
42" (41.94")	24" (23.68")	22 7/8"	16 7/16"
	30" (29.68")	28 7/8"	20 11/16"
	36" (35.68")	31 7/8"	22 13/16"
	42" (41.68")	37 7/8"	27 1/16"

Product Details – Jive Tables

X-Base – Square (Top)

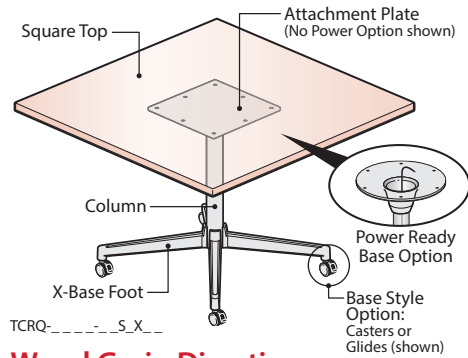

Wood Grain Direction

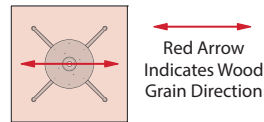

Top Cutout Options

- Power and Data access may be provided by specifying optional factory installed cutout.
- Cutouts are designed to accommodate separately specified Grommets or Power/Data Dome.

Cutout Location

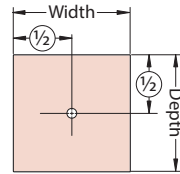

N No Cutout

- R 3" Cutout** (With Power Ready Base Option only)



Base & Wire Management Options

Base - No Power

Does not provide access for cord management.

Base - Power Ready

Provides access for cord management through the top to the bottom of the column.

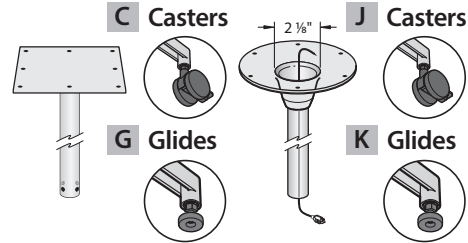

Component Materials/Finishes

COMPONENT NAME		MATERIALS/ FINISHES	
Square Top	Edge Option is applied to all edges.	(L) Laminate – Specify separate top and edge finish colors.	(J) Edgeband
		(W) Wood – Specify a single finish color for top and edge.	(F) Knife (K) Edgeband (U) Knife
X Base	Foot, Column and Attachment Plate	(A) Painted – The Foot, Column and Attachment Plate are painted metal, specify base trim color.	
		(B) Polished – The Foot is polished aluminum. The Column and Attachment Plate are painted metal, specify base trim color.	
	Base Style	Casters – Standard in black.	
		Glides – Standard in black.	

Sizes and Dimensions

Top View – No Power with Casters

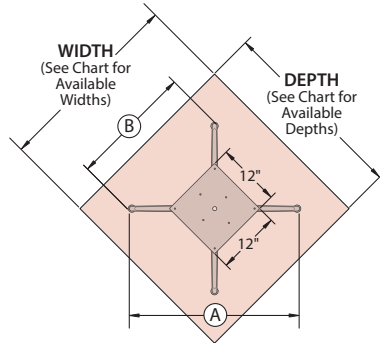

Top View – Power Ready with Glides

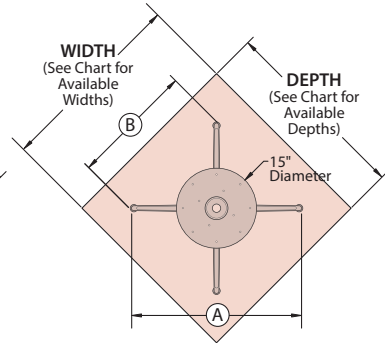

Front View – Power Ready with Glides

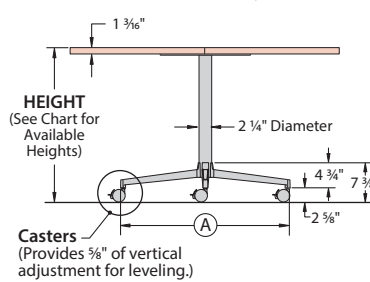

Front View – No Power with Casters

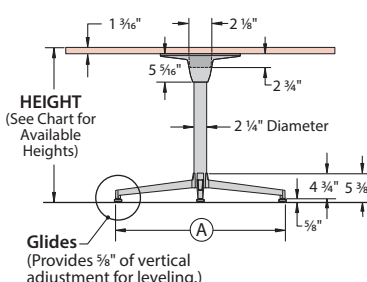
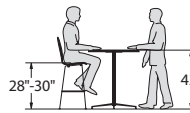

Table Heights

42" High Tables

- Seated or standing applications.
- Specify with bar height stools (28"-30" seat heights).



36" High Tables

- Seated or standing applications.
- Specify with counter height stools (24"-26" seat heights).

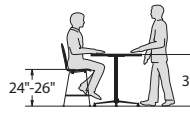

29" High Tables

- Seated applications.
- Specify with standard height seating (17"-18" seat heights).



20" High Tables

- Seated or lounge applications.
- Specify with standard or lounge height seating (14"-18" seat heights).

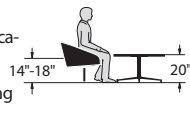

16" High Tables

- Seated or lounge applications.
- Specify with standard or lounge height seating (14"-18" seat heights).

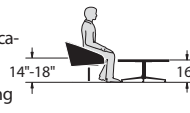

HEIGHT Nominal (Actual)	WIDTH/ DEPTH Nominal (Actual)	(A)	(B)
16" (15.94")	24" (23.68")	22 7/8"	16 7/16"
	30" (29.68")	28 7/8"	20 11/16"
	36" (35.68")	31 7/8"	22 13/16"
	42" (41.68")	37 7/8"	27 1/16"
20" (19.94")	24" (23.68")	22 7/8"	16 7/16"
	30" (29.68")	28 7/8"	20 11/16"
	36" (35.68")	31 7/8"	22 13/16"
	42" (41.68")	37 7/8"	27 1/16"
29" (28.94")	24" (23.68")	22 7/8"	16 7/16"
	30" (29.68")	28 7/8"	20 11/16"
	36" (35.68")	31 7/8"	22 13/16"
	42" (41.68")	37 7/8"	27 1/16"
36" (35.94")	24" (23.68")	22 7/8"	16 7/16"
	30" (29.68")	28 7/8"	20 11/16"
	36" (35.68")	31 7/8"	22 13/16"
	42" (41.68")	37 7/8"	27 1/16"
42" (41.94")	24" (23.68")	22 7/8"	16 7/16"
	30" (29.68")	28 7/8"	20 11/16"
	36" (35.68")	31 7/8"	22 13/16"
	42" (41.68")	37 7/8"	27 1/16"

Product Details – Jive Tables

X-Base – No Power Ready Base Option – Pebble (Top)

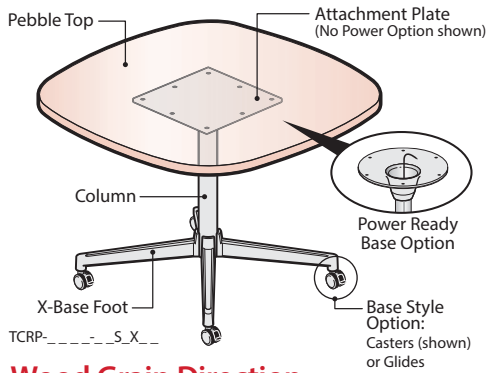

Component Materials/Finishes

COMPONENT NAME		MATERIALS/ FINISHES	
Pebble Top	Edge Option is applied to all edges.	(L) Laminate – Specify separate top and edge finish colors.	(J) Edgeband
		(W) Wood – Specify a single finish color for top and edge.	(F) Knife (K) Edgeband (U) Knife
X Base	Foot, Column and Attachment Plate	(A) Painted – The Foot, Column and Attachment Plate are painted metal, specify base trim color. (B) Polished – The Foot is polished aluminum. The Column and Attachment Plate are painted metal, specify base trim color.	
	Base Style	Casters – Standard in black. Glides – Standard in black.	

Wood Grain Direction

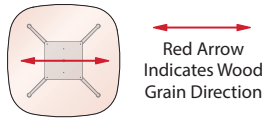

Top Cutout Options

- Power and Data access may be provided by specifying optional factory installed cutout.
- Cutouts are designed to accommodate separately specified Grommets or Power/Data Dome.

Cutout Location

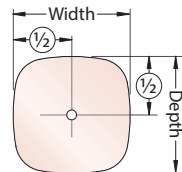

N No Cutout

- R 3" Cutout** (With Power Ready Base Option only) – 3" Diameter Round Cutout



Base & Wire Management Options

Base - No Power

Does not provide access for cord management.

Base - Power Ready

Provides access for cord management through the top to the bottom of the column.

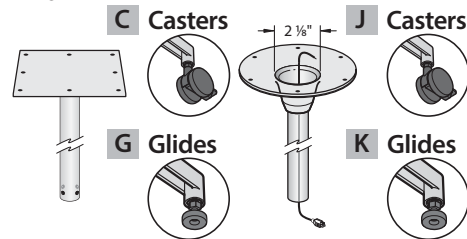

Sizes and Dimensions

Top View – No Power with Casters

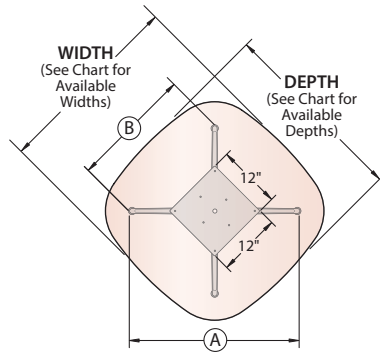

Top View – Power Ready with Glides

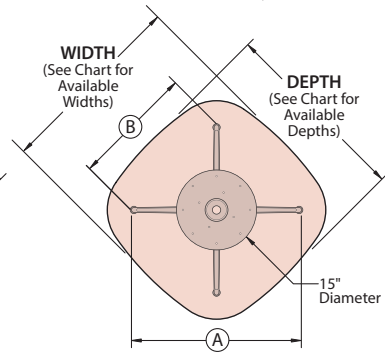

Front View – Power Ready with Glides

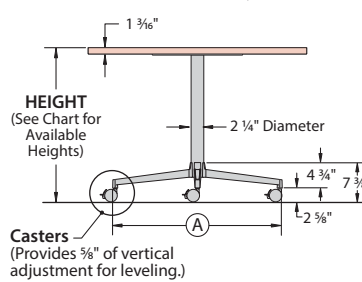

Front View – No Power with Casters

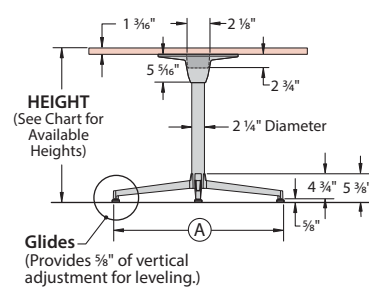

Table Heights

42" High Tables

- Seated or standing applications.
- Specify with bar height stools (28"-30" seat heights).



36" High Tables

- Seated or standing applications.
- Specify with counter height stools (24"-26" seat heights).

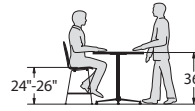

29" High Tables

- Seated applications.
- Specify with standard height seating (17"-18" seat heights).



20" High Tables

- Seated or lounge applications.
- Specify with standard or lounge height seating (14"-18" seat heights).

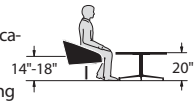

16" High Tables

- Seated or lounge applications.
- Specify with standard or lounge height seating (14"-18" seat heights).

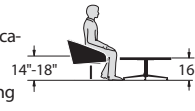

HEIGHT Nominal (Actual)	WIDTH/ DEPTH Nominal (Actual)	A	B
16" (15.94")	24" (23.68")	22 7/8"	16 7/16"
	30" (29.68")	28 7/8"	20 11/16"
	36" (35.68")	31 7/8"	22 13/16"
	42" (41.68")	37 7/8"	27 1/16"
20" (19.94")	24" (23.68")	22 7/8"	16 7/16"
	30" (29.68")	28 7/8"	20 11/16"
	36" (35.68")	31 7/8"	22 13/16"
	42" (41.68")	37 7/8"	27 1/16"
29" (28.94")	24" (23.68")	22 7/8"	16 7/16"
	30" (29.68")	28 7/8"	20 11/16"
	36" (35.68")	31 7/8"	22 13/16"
	42" (41.68")	37 7/8"	27 1/16"
36" (35.94")	24" (23.68")	22 7/8"	16 7/16"
	30" (29.68")	28 7/8"	20 11/16"
	36" (35.68")	31 7/8"	22 13/16"
	42" (41.68")	37 7/8"	27 1/16"
42" (41.94")	24" (23.68")	22 7/8"	16 7/16"
	30" (29.68")	28 7/8"	20 11/16"
	36" (35.68")	31 7/8"	22 13/16"
	42" (41.68")	37 7/8"	27 1/16"

Product Details – Jive Tables

X-Base – Rectangle (Top)

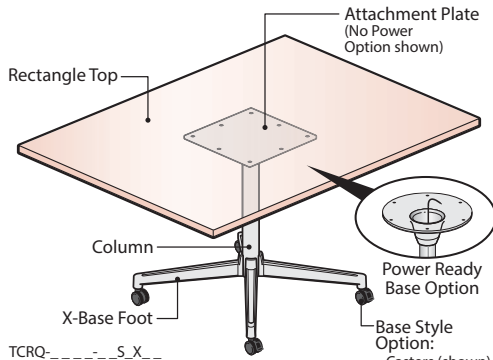

Wood Grain Direction

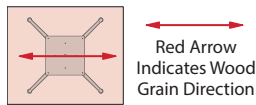

Top Cutout Options

- Power and Data access may be provided by specifying optional factory installed cutout.
- Cutouts are designed to accommodate separately specified Grommets or Power/Data Dome.

Cutout Location

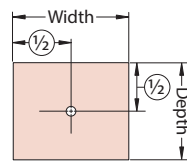

N No Cutout

- R 3" Cutout** (With Power Ready Base Option only) - 3" Diameter Round Cutout



Base & Wire Management Options

Base - No Power

Does not provide access for cord management.

Base - Power Ready

Provides access for cord management through the top to the bottom of the column.

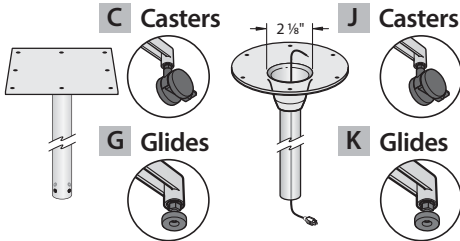

Component Materials/Finishes

COMPONENT NAME		MATERIALS/ FINISHES	
Square Top	Edge Option is applied to all edges.	(L) Laminate – Specify separate top and edge finish colors.	(J) Edgeband
		(W) Wood – Specify a single finish color for top and edge.	(F) Knife (K) Edgeband (U) Knife
X Base	Foot, Column and Attachment Plate	(A) Painted – The Foot, Column and Attachment Plate are painted metal, specify base trim color. (B) Polished – The Foot is polished aluminum. The Column and Attachment Plate are painted metal, specify base trim color.	
	Base Style	Casters – Standard in black. Glides – Standard in black.	

Sizes and Dimensions

Top View – No Power with Casters

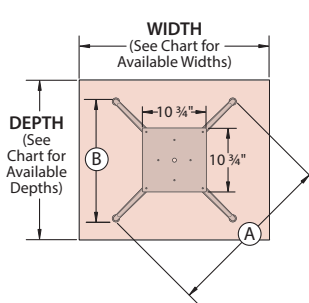

Front View – No Power with Casters

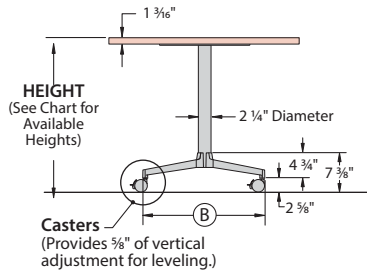

Top View – Power Ready with Glides

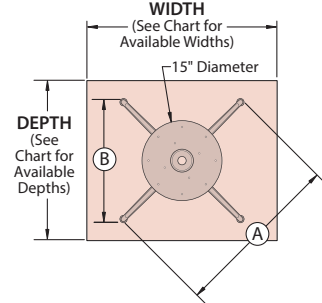

Front View – Power Ready with Glides

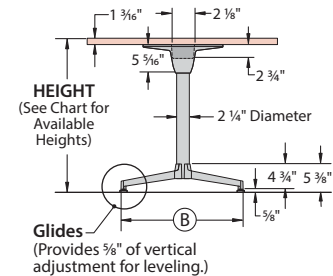

Table Heights

42" High Tables

- Seated or standing applications.
- Specify with bar height stools (28"-30" seat heights).



36" High Tables

- Seated or standing applications.
- Specify with counter height stools (24"-26" seat heights).



29" High Tables

- Seated applications.
- Specify with standard height seating (17"-18" seat heights).



20" High Tables

- Seated or lounge applications.
- Specify with standard or lounge height seating (14"-18" seat heights).

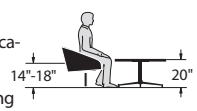

16" High Tables

- Seated or lounge applications.
- Specify with standard or lounge height seating (14"-18" seat heights).

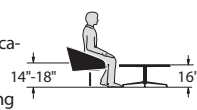

HEIGHT Nominal (Actual)	WIDTH Nominal (Actual)	DEPTH Nominal (Actual)	(A)	(B)
16" (15.94")	24" (23.68")	30" (29.68")	28 7/8"	20 1/16"
	30" (29.68")	36" (35.68")	31 7/8"	22 13/16"
	42" (41.68")	42" (41.68")	37 7/8"	27 1/16"
20" (19.94")	24" (23.68")	30" (29.68")	28 7/8"	20 1/16"
	30" (29.68")	36" (35.68")	31 7/8"	22 13/16"
	42" (41.68")	42" (41.68")	37 7/8"	27 1/16"
29" (28.94")	24" (23.68")	30" (29.68")	28 7/8"	20 1/16"
	30" (29.68")	36" (35.68")	31 7/8"	22 13/16"
	42" (41.68")	42" (41.68")	37 7/8"	27 1/16"
36" (35.94")	24" (23.68")	30" (29.68")	28 7/8"	20 1/16"
	30" (29.68")	36" (35.68")	31 7/8"	22 13/16"
	42" (41.68")	42" (41.68")	37 7/8"	27 1/16"
42" (41.94")	24" (23.68")	30" (29.68")	28 7/8"	20 1/16"
	30" (29.68")	36" (35.68")	31 7/8"	22 13/16"
	42" (41.68")	42" (41.68")	37 7/8"	27 1/16"

Product Details – Jive Tables

Bridge Base (4 Columns) – Round (Top)

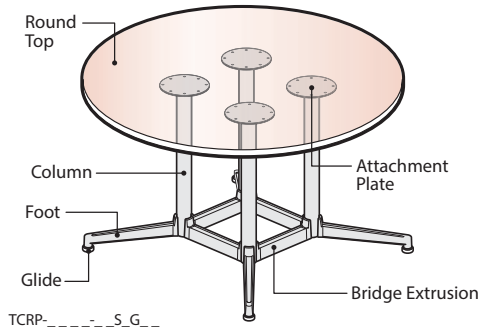

Component Materials/Finishes

COMPONENT NAME		MATERIALS/ FINISHES	
Round Top	Edge Option is applied to all edges.	(L) Laminate – Specify separate top and edge finish colors.	(J) Edgeband
		(W) Wood – Specify a single finish color for top and edge.	(F) Knife (K) Edgeband (U) Knife
Bridge Base	Feet, Bridge Extrusion Columns and Attachment Plates	(A) Painted – The Foot, Bridge Extrusion, Column and Attachment Plate are painted metal, specify base trim color.	
		(B) Polished – The Foot and Bridge Extrusion is polished aluminum. The Column and Attachment Plate are painted metal, specify base trim color.	
	Base Style	Glides – Standard in black.	

Wood Grain Direction

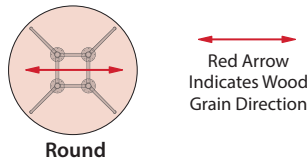

Top Cutout Options

- Power and Data access may be provided by specifying optional factory installed cutouts.
- Cutouts are designed to accommodate separately specified Flip Top Units.

Cutout Location

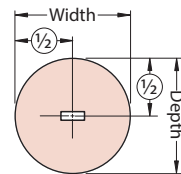

N No Cutout

F Center Power

Cutout for 4-Port Single Sided Flip Top Unit

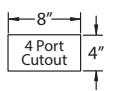

J Center Power

Cutout for 6-Port Single Sided Flip Top Unit

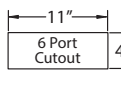

M Center Power

Cutout for 8-Port Double Sided Flip Top Unit

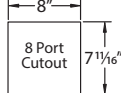

Sizes and Dimensions

Top View

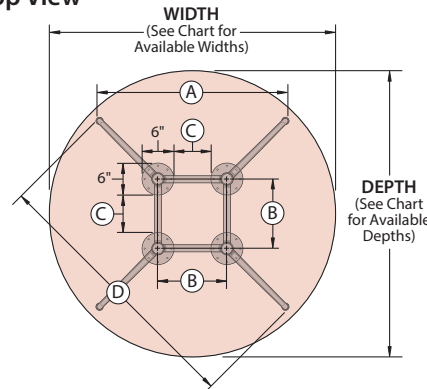

Front View

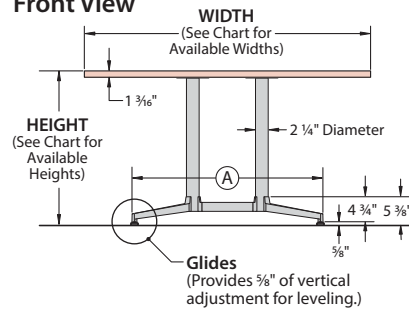

Base & Wire Management Options

- The 4 Column Bridge Base is standard with glides only, casters are not available.
- Casters and glides are not interchangeable.

Base - No Power

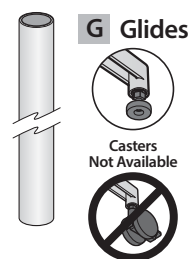

Does not provide access for cord management.

Base - Power Ready

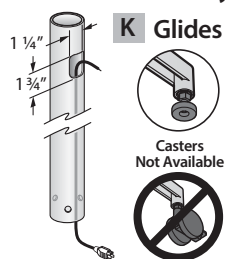

Provides access for cord management through (1) of the Round Columns. Power ready leg location determined during installation.

HEIGHT Nominal (Actual)	WIDTH/ DEPTH Nominal (Actual)	Component Dimensions				Caster/Glide Availability	
		A	B	C	D	Casters	Glides
20" (19.94")	48" (47.68")	33 1/16"	13"	7"	47 1/4"	No	Yes
	54" (53.68")	35 1/16"	13"	7"	50 1/4"	No	Yes
	60" (59.68")	40 1/16"	18"	12"	57 5/16"	No	Yes
29" (28.94")	48" (47.68")	33 1/16"	13"	7"	50 1/4"	No	Yes
	54" (53.68")	35 1/16"	13"	7"	50 1/4"	No	Yes
	60" (59.68")	40 1/16"	18"	12"	57 5/16"	No	Yes

Table Heights

29" High Tables

- Seated applications.
- Specify with standard height seating (17"-18" seat heights).



20" High Tables

- Seated or lounge applications.
- Specify with standard or lounge height seating (14"-18" seat heights).

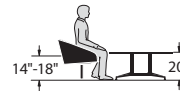

Seating Capacity

- Recommended seating capacity is based upon a width of 27" per chair.

WIDTH/DEPTH		
48"	54"	60"
5 Chairs Maximum	6 Chairs Maximum	7 Chairs Maximum

Product Details – Jive Tables

Bridge Base (4 Columns) – Square (Top)

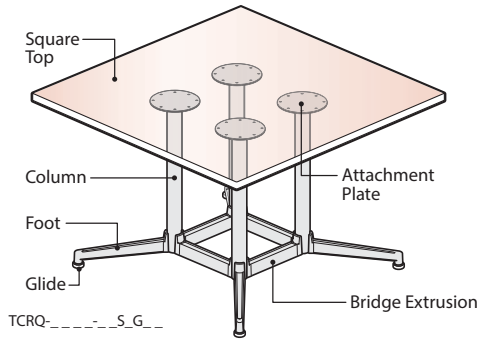

Component Materials/Finishes

COMPONENT NAME	MATERIALS/ FINISHES	
Square Top Edge Option is applied to all edges.	(L) Laminate – Specify separate top and edge finish colors.	(J) Edgeband
	(W) Wood – Specify a single finish color for top and edge.	(F) Knife (K) Edgeband (U) Knife
Bridge Base	(A) Painted – The Foot, Bridge Extrusion, Column and Attachment Plate are painted metal, specify base trim color.	
	(B) Polished – The Foot and Bridge Extrusion is polished aluminum. The Column and Attachment Plate are painted metal, specify base trim color.	
Base Style	Glides – Standard in black.	

Wood Grain Direction

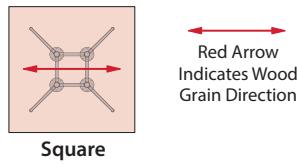

Top Cutout Options

- Power and Data access may be provided by specifying optional factory installed cutouts.
- Cutouts are designed to accommodate separately specified Flip Top Units.

N No Cutout

F Center Power Cutout for 4-Port Single Sided Flip Top Unit



J Center Power Cutout for 6-Port Single Sided Flip Top Unit

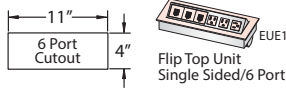

M Center Power Cutout for 8-Port Double Sided Flip Top Unit

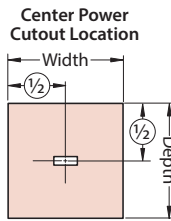
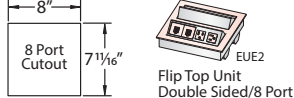

Sizes and Dimensions

Top View

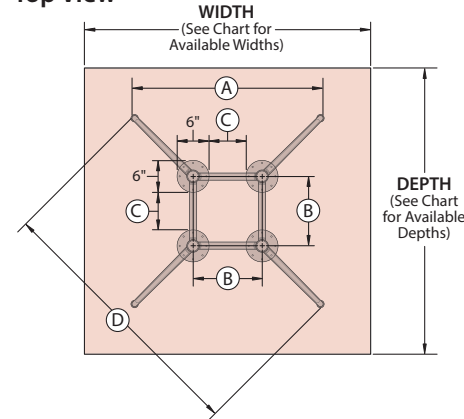

Front View

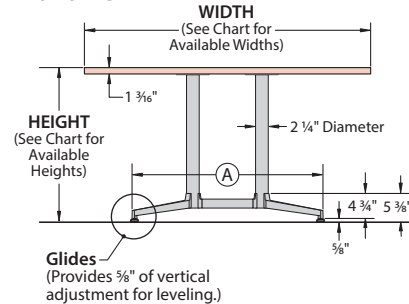

Base & Wire Management Options

- The 4 Column Bridge Base is standard with glides only, casters are not available.
- Casters and glides are not interchangeable.

Base - No Power

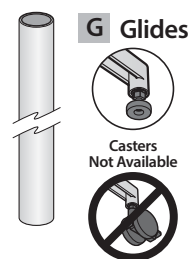

Does not provide access for cord management.

Base - Power Ready

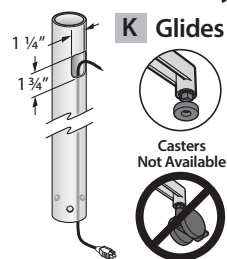

Provides access for cord management through (1) of the Round Columns. Power ready leg location determined during installation.

HEIGHT Nominal (Actual)	WIDTH/ DEPTH Nominal (Actual)	Component Dimensions				Caster/Glide Availability	
		A	B	C	D	Casters	Glides
20" (19.94")	48" (47.68")	35 13/16"	13"	7"	50 1/4"	No	Yes
	54" (53.68")	35 13/16"	13"	7"	50 1/4"	No	Yes
	60" (59.68")	40 13/16"	18"	12"	57 3/8"	No	Yes
29" (28.94")	48" (47.68")	35 13/16"	13"	7"	50 1/4"	No	Yes
	54" (53.68")	35 13/16"	13"	7"	50 1/4"	No	Yes
	60" (59.68")	40 13/16"	18"	12"	57 3/8"	No	Yes

Table Heights

29" High Tables

- Seated applications.
- Specify with standard height seating (17"-18" seat heights).



20" High Tables

- Seated or lounge applications.
- Specify with standard or lounge height seating (14"-18" seat heights).



Seating Capacity

- Recommended seating capacity is based upon a width of 27" per chair.

WIDTH/DEPTH		
48"	54"	60"
4 Chairs Maximum	4 Chairs Maximum	8 Chairs Maximum

Product Details – Jive Tables

Bridge Base (4 Column) – Symmetrical Pebble (Top)

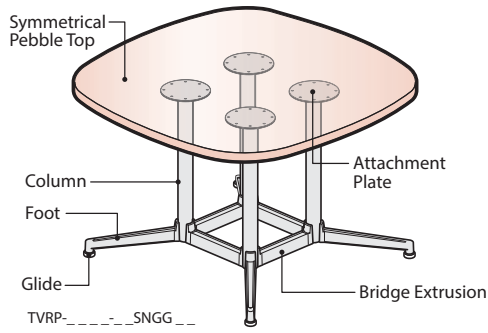

Component Materials/Finishes

COMPONENT NAME		MATERIALS/ FINISHES	
Round Top Edge Option is applied to all edges.	(L) Laminate – Specify separate top and edge finish colors.	(J) Edgeband	(F) Knife
	(W) Wood – Specify a single finish color for top and edge.	(K) Edgeband	(U) Knife
Bridge Base	Feet, Bridge Extrusion Columns and Attachment Plates	(A) Painted – The Foot, Bridge Extrusion, Column and Attachment Plate are painted metal, specify base trim color.	
		(B) Polished – The Foot and Bridge Extrusion is polished aluminum. The Column and Attachment Plate are painted metal, specify base trim color.	
Base Style	Casters – Standard in black.		
	Glides – Standard in black.		

Wood Grain Direction

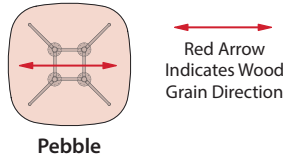

Sizes and Dimensions

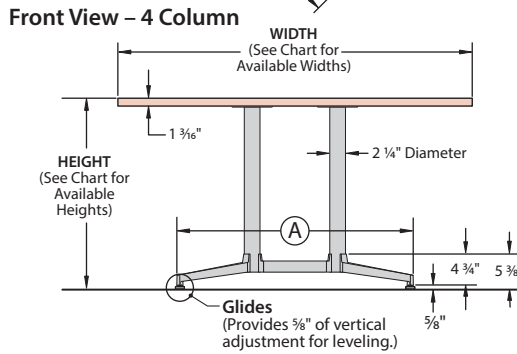
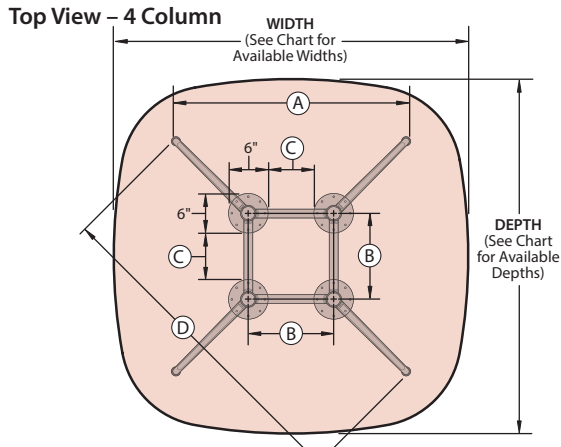

Top Cutout Options

- Power and Data access may be provided by specifying optional factory installed cutouts.
- Cutouts are designed to accommodate separately specified Flip Top Units.

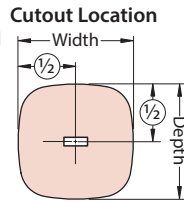

N No Cutout

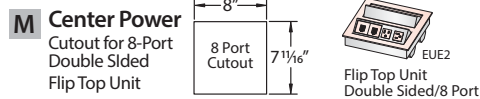
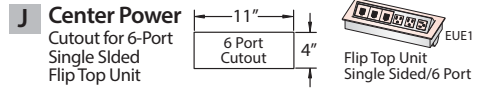
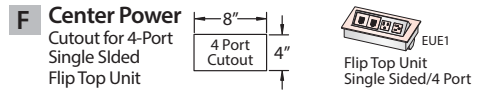

Base & Wire Management Options

Base - No Power

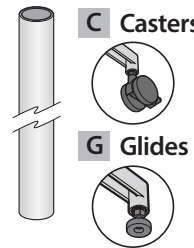

Does not provide access for cord management.

Base - Power Ready

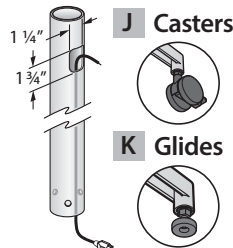

Provides access for cord management through (1) of the Round Columns. Power ready leg location determined during installation.

- Note**
- Only the 29" high Tables may be specified with the caster option. 20" high Tables are standard with Glides only.
 - Casters and glides are not interchangeable.

HEIGHT Nominal (Actual)	WIDTH/DEPTH Nominal (Actual)	Component Dimensions				Caster/Glide Availability	
		A	B	C	D	Casters	Glides
20" (19.94")	48" (47.68")	35 13/16"	13"	7"	50 1/4"	No	Yes
	54" (53.68")	35 13/16"	13"	7"	50 1/4"	No	Yes
	60" (59.68")	40 13/16"	18"	12"	57 3/8"	No	Yes
29" (28.94")	48" (47.68")	35 13/16"	13"	7"	50 1/4"	Yes	Yes
	54" (53.68")	35 13/16"	13"	7"	50 1/4"	Yes	Yes
	60" (59.68")	40 13/16"	18"	12"	57 3/8"	Yes	Yes

Table Heights

29" High Tables

- Seated applications.
- Specify with standard height seating (17"-18" seat heights).



20" High Tables

- Seated or lounge applications.
- Specify with standard or lounge height seating (14"-18" seat heights).



Seating Capacity

- Recommended seating capacity is based upon a width of 27" per chair.

WIDTH/DEPTH		
48"	54"	60"
4 Chairs Maximum	4 Chairs Maximum	8 Chairs Maximum

Product Details – Jive Tables

Bridge Base (2 Columns) – Asymmetrical Pebble (Top)

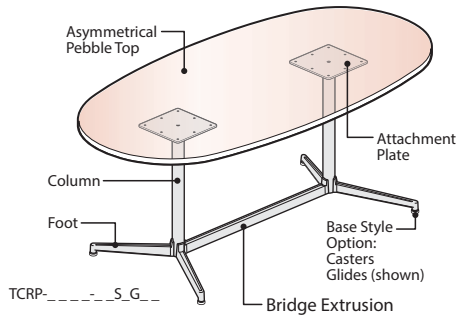

Wood Grain Direction



Top Cutout Options

- Power and Data access may be provided by specifying optional factory installed cutouts.
- Cutouts are designed to accommodate separately specified Flip Top Units.

Cutout Location

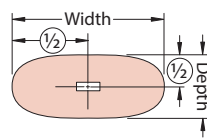

N No Cutout

F Center Power
Cutout for 4-Port Single Sided Flip Top Unit

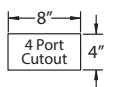

J Center Power
Cutout for 6-Port Single Sided Flip Top Unit

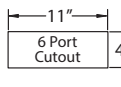

M Center Power
Cutout for 8-Port Double Sided Flip Top Unit

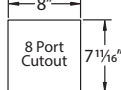

Q Center Power
Cutout for 12-Port Double Sided Flip Top Unit

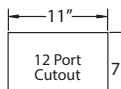

Base & Wire Management Options

Base - No Power

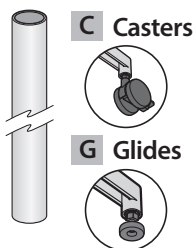

Does not provide access for cord management.

Base - Power Ready

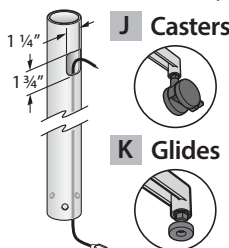

Provides access for cord management through (1) of the Round Column. Power ready leg location determined during installation.

Note Only the 29" and 42" high Tables may be specified with the caster option. All other heights are standard with Glides only.

Component Materials/Finishes

COMPONENT NAME		MATERIALS/ FINISHES	
Round Top Edge Option is applied to all edges.		(L) Laminate – Specify separate top and edge finish colors.	(J) Edgeband
		(W) Wood – Specify a single finish color for top and edge.	(F) Knife (K) Edgeband (U) Knife
Bridge Base	Feet, Bridge Extrusion Columns and Attachment Plates	(A) Painted – The Foot, Bridge Extrusion, Column and Attachment Plate are painted metal, specify base trim color.	
	Base Style	(B) Polished – The Foot and Bridge Extrusion is polished aluminum. The Column and Attachment Plate are painted metal, specify base trim color.	
		Casters – Standard in black.	
		Glides – Standard in black.	

Sizes and Dimensions

Top View – 2 Column

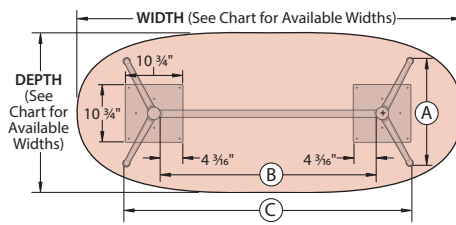

Front View – 2 Column with Glides

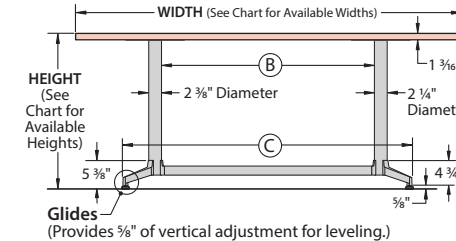

Front View – 2 Column with Casters

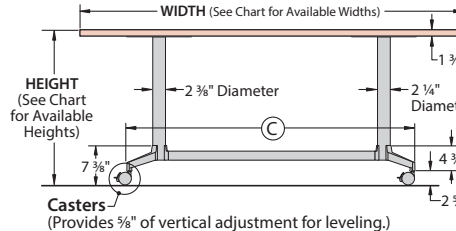

Table Heights

42" High Tables

- Seated or standing applications.
- Specify with bar height stools (28"-30" seat heights).



36" High Tables

- Seated or standing applications.
- Specify with counter height stools (24"-26" seat heights).



29" High Tables

- Seated applications.
- Specify with standard height seating (17"-18" seat heights).

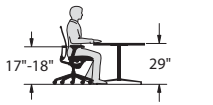

20" High Tables

- Seated or lounge applications.
- Specify with standard/lounge seating (14"-18" seat heights).



16" High Tables

- Seated or lounge applications.
- Specify with standard/lounge seating (14"-18" seat heights).



Seating Capacity

Recommended seating capacity based upon a width of 27" per chair.

Table Height	Table Width	Seating Capacity
30" Deep	48" Wide	(4) Chairs Max.
30" Deep	60" Wide	(6) Chairs Max.
30" Deep	72" Wide	(6) Chairs Max.
36" Deep	60" Wide	(6) Chairs Max.
36" Deep	72" Wide	(6) Chairs Max.

HEIGHT Nominal (Actual)	DEPTH Nominal (Actual)	WIDTH Nominal (Actual)	Component Dimensions			Caster/Glide Availability	
			A	B	C	Casters	Glides
16" (15.94")	30" (29.68")	48" (47.68")	19 1/16"	21 3/4"	35 3/8"	No	Yes
	60" (59.68")	19 1/16"	27 3/4"	41 7/8"	No	Yes	
	72" (71.68")	19 1/16"	39 3/4"	53 7/8"	No	Yes	
	36" (35.68")	60" (59.68")	27 3/4"	27 3/4"	46 7/8"	No	Yes
20" (19.94")	30" (29.68")	48" (47.68")	19 1/16"	21 3/4"	35 3/8"	No	Yes
	60" (59.68")	19 1/16"	27 3/4"	41 7/8"	No	Yes	
	72" (71.68")	19 1/16"	39 3/4"	53 7/8"	No	Yes	
	36" (35.68")	60" (59.68")	27 3/4"	27 3/4"	46 7/8"	No	Yes
29" (28.94")	30" (29.68")	48" (47.68")	19 1/16"	21 3/4"	35 3/8"	Yes	Yes
	60" (59.68")	19 1/16"	27 3/4"	41 7/8"	Yes	Yes	
	72" (71.68")	19 1/16"	39 3/4"	53 7/8"	Yes	Yes	
	36" (35.68")	60" (59.68")	27 3/4"	27 3/4"	46 7/8"	Yes	Yes
36" (35.94")	30" (29.68")	48" (47.68")	19 1/16"	21 3/4"	35 3/8"	No	Yes
	60" (59.68")	19 1/16"	27 3/4"	41 7/8"	No	Yes	
	72" (71.68")	19 1/16"	39 3/4"	53 7/8"	No	Yes	
	36" (35.68")	60" (59.68")	27 3/4"	27 3/4"	46 7/8"	No	Yes
42" (41.94")	30" (29.68")	48" (47.68")	19 1/16"	21 3/4"	35 3/8"	Yes	Yes
	60" (59.68")	19 1/16"	27 3/4"	41 7/8"	Yes	Yes	
	72" (71.68")	19 1/16"	39 3/4"	53 7/8"	Yes	Yes	
	36" (35.68")	60" (59.68")	27 3/4"	27 3/4"	46 7/8"	Yes	Yes

Product Details – Jive Tables

Bridge Base (3 Columns) – Asymmetrical Pebble (Top)

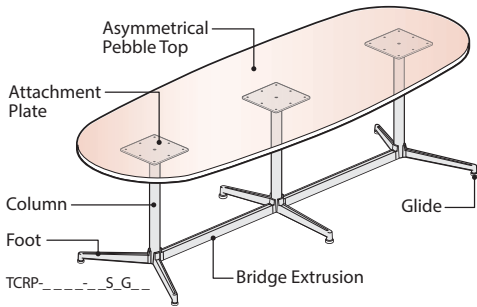

Component Materials/Finishes

COMPONENT NAME	MATERIALS/ FINISHES	
Pebble Top Edge Option is applied to all edges.	(L) Laminate – Specify separate top and edge finish colors.	(J) Edgeband
	(W) Wood – Specify a single finish color for top and edge.	(F) Knife (K) Edgeband (U) Knife
Bridge Base	(A) Painted – The Foot, Bridge Extrusion, Column and Attachment Plate are painted metal, specify base trim color.	
	(B) Polished – The Foot and Bridge Extrusion is polished aluminum. The Column and Attachment Plate are painted metal, specify base trim color.	
Base Style	Casters – Standard in black.	
	Glides – Standard in black.	

Wood Grain Direction

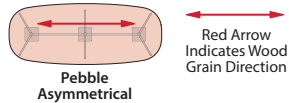

Top Cutout Options

- Power and Data access may be provided by specifying optional factory installed cutouts.
- Cutouts are designed to accommodate separately specified Flip Top Units.

Left/Right Power Cutout Locations

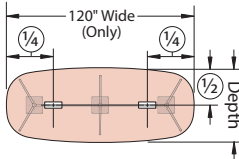

N No Cutout

V Left/Right Power Cutout for 4-Port Single Slided Flip Top Unit

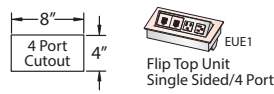

K Left/Right Power Cutout for 6-Port Single Slided Flip Top Unit

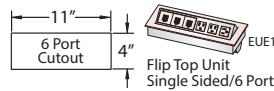

Note 84", 96" and 108" Wide Tables are standard with (N) No Cutout, due to interference with the attachment plates.

Base & Wire Management Options

- The 3 Column Bridge Base is standard with glides only, casters are not available.
- Casters and glides are not interchangeable.

Base - No Power

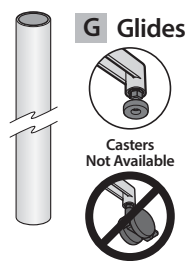

Does not provide access for cord management.

Base - Power Ready

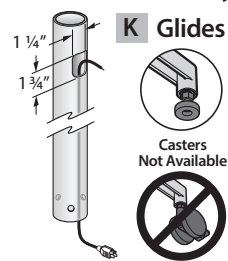

Provides access for cord management through (1) of the Round Column. Power ready leg location determined during installation.

Table Heights

29" High Tables

- Seated applications.
- Specify with standard height seating (17"-18" seat heights).



Sizes and Dimensions

Top View – 3 Column

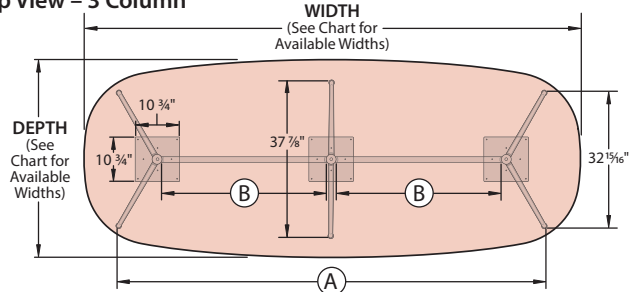

Front View – 3 Column (Shown with Glides)

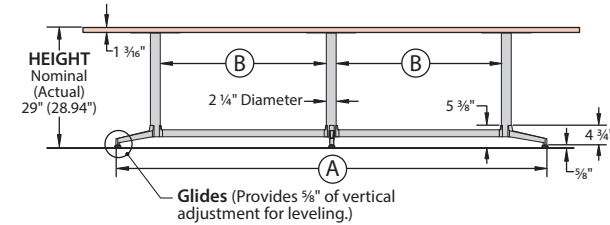

HEIGHT Nominal (Actual)	DEPTH Nominal (Actual)	WIDTH Nominal (Actual)	Number of Columns	Component Dimensions		Cutout Option Availability	Caster/Glide Availability	
				A	B		Casters	Glides
29" (28.94")	42" (41.68")	84" (83.68")	3	67 3/8"	21 3/4"	(N) No Cutout	Yes	Yes
		96" (95.68")	3	79 3/8"	27 3/4"	(N) No Cutout	Yes	Yes
	96" (95.68")	3	79 3/8"	27 3/4"	(N) No Cutout	Yes	Yes	
	108" (107.68")	3	91 3/8"	33 3/4"	(N) No Cutout	Yes	Yes	
	120" (119.68")	3	103 3/8"	39 3/4"	(N), (V) or (K) Cutout Options	Yes	Yes	

Seating Capacity

Recommended seating capacity based upon a width of 27" per chair.

DEPTH	WIDTH			
	84" Wide	96" Wide	108" Wide	120" Wide
42" Deep	6 Chairs Maximum	8 Chairs Maximum	N/A	N/A
48" Deep	N/A	8 Chairs Maximum	8 Chairs Maximum	10 Chairs Maximum

Product Details – Jive Tables

Bridge Base (6 Columns) – Asymmetrical Pebble (Top)

1-Piece Top (96", 108" and 120" wide)

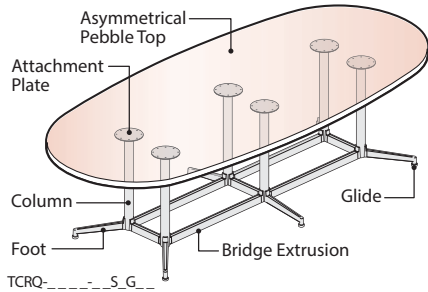

2-Piece Top (144" wide)

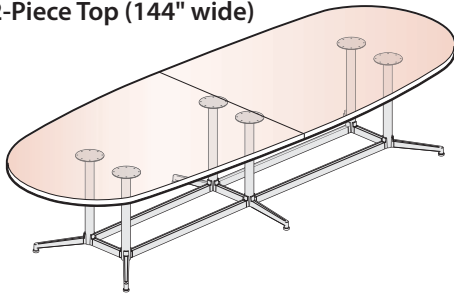

TCQR-...S.G.

Wood Grain Direction

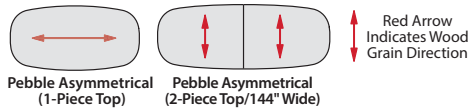
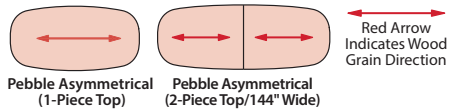
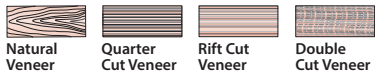

Note When laminate wood grain is specified for multi-piece tops the grain may not match.

Base & Wire Management Options

- The 4 Column Bridge Base is standard with glides only, casters are not available.
- Casters and glides are not interchangeable.

Base - No Power

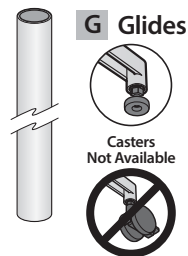

Does not provide access for cord management.

Base - Power Ready

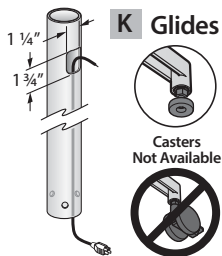

Provides access for cord management through (1) of the Round Column. Power ready leg location determined during installation.

Component Materials/Finishes

COMPONENT NAME		MATERIALS/ FINISHES	
Asymmetrical Pebble Top	Edge Option is applied to all edges.	(L) Laminate – Specify separate top and edge finish colors.	(J) Edgeband
		(W) Wood – Specify a single finish color for top and edge.	(F) Knife (K) Edgeband (U) Knife
Bridge Base	Feet, Bridge Extrusion Columns and Attachment Plates	(A) Painted – The Foot, Bridge Extrusion, Column and Attachment Plate are painted metal, specify base trim color.	(B) Polished – The Foot and Bridge Extrusion is polished aluminum. The Column and Attachment Plate are painted metal, specify base trim color.
		Base Style	

Top Cutout Options

- Power and Data access may be provided by specifying optional factory installed cutouts.
- Cutouts are designed to accommodate separately specified Flip Top Units.

N No Cutout

Center Power Cutout Locations

1-Piece Top – (1) Cutout

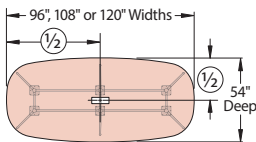

F Center Power

Cutout for 4-Port Single Slided Flip Top Unit



Flip Top Unit Single Sided/4 Port

J Center Power

Cutout for 6-Port Single Slided Flip Top Unit

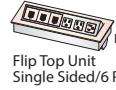
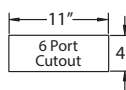

Flip Top Unit Single Sided/6 Port

M Center Power

Cutout for 8-Port Double Slided Flip Top Unit

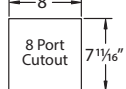

Flip Top Unit Double Sided/8 Port

Q Center Power

Cutout for 12-Port Double Slided Flip Top Unit

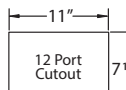

Flip Top Unit Double Sided/12 Port

Left/Right Power Cutout Locations

1-Piece Top – (2) Cutouts

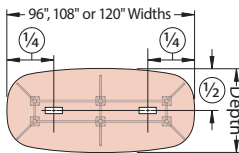

V Left/Right Power

Cutout for 4-Port Single Slided Flip Top Unit

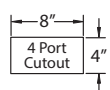

Flip Top Unit Single Sided/4 Port

K Left/Right Power

Cutout for 6-Port Single Slided Flip Top Unit

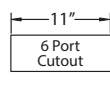

Flip Top Unit Single Sided/6 Port

Table Heights

29" High Tables

- Seated applications.
- Specify with standard height seating (17"-18" seat heights).



Product Details – Jive Tables

Bridge Base (6 Columns) – Asymmetrical Pebble (Top)

Sizes and Dimensions

1-Piece Top (96", 108" and 120" wide) – Shown with Glides

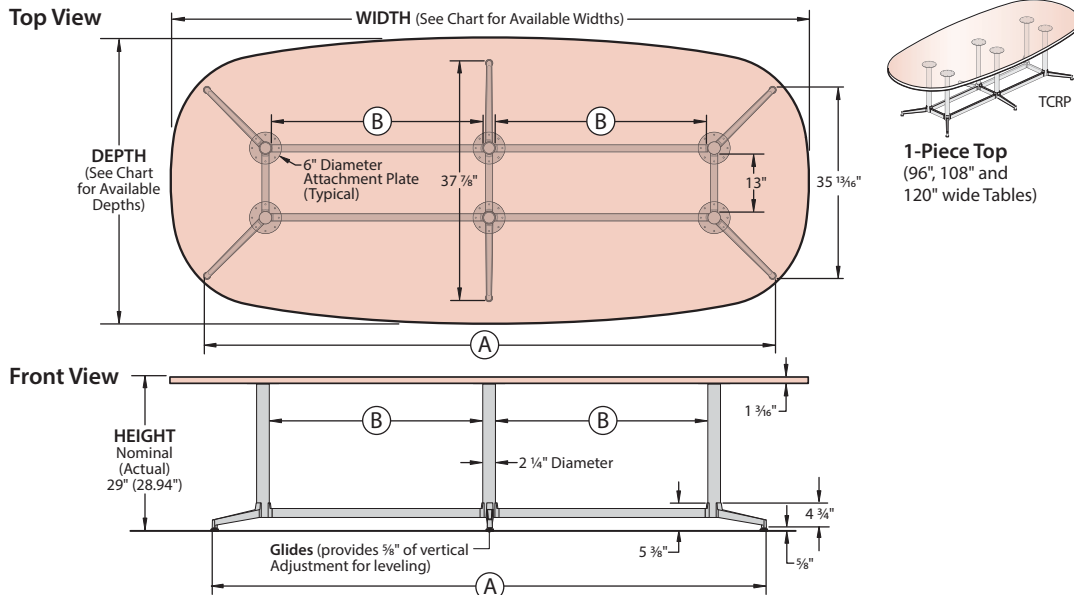

2-Piece Top (144" wide) – Shown with Casters

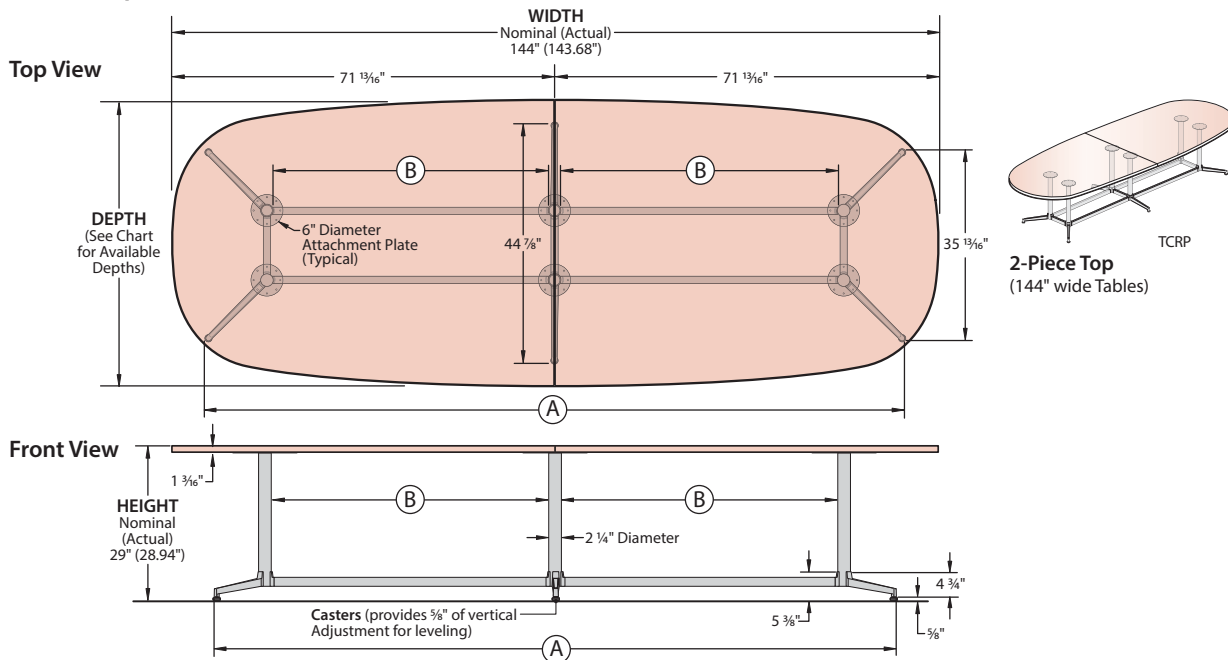

HEIGHT Nominal (Actual)	DEPTH Nominal (Actual)	WIDTH Nominal (Actual)	Number of Columns	Number of Top Pieces	Component Dimensions		Caster/Glide Availability	
					(A)	(B)	Casters	Glides
29" (28.94")	54" (53.68")	96" (95.68")	6	1	82 13/16"	27 3/4"	Yes	Yes
		108" (107.68")	6	1	94 13/16"	33 3/4"	Yes	Yes
		120" (119.68")	6	1	106 13/16"	39 3/4"	Yes	Yes
		144" (143.68")	6	2	118 13/16"	45 3/4"	Yes	Yes

Seating Capacity

Recommended seating capacity based upon a width of 27" per chair.

DEPTH	WIDTH			
	96" Wide	108" Wide	120" Wide	144" Wide
54" Deep	 8 Chairs Maximum	 8 Chairs Maximum	 10 Chairs Maximum	 12 Chairs Maximum

Product Details – Jive Tables

Bridge Base (8 Columns) – Asymmetrical Pebble (Top)

2-Piece Top (180" wide)

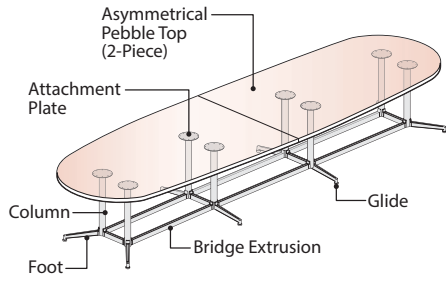

TCRQ-----S_G---

3-Piece Top (216" wide)

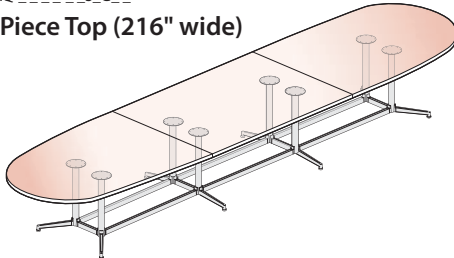

TCRQ-----S_G---

Wood Grain Direction

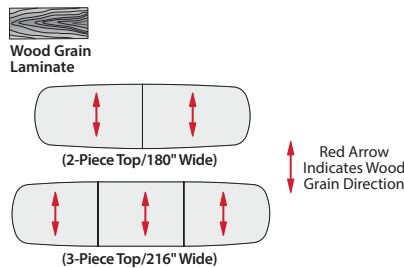
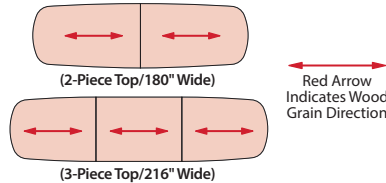
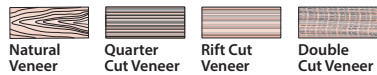

Note When laminate wood grain is specified for multi-piece tops the grain may not match.

Base & Wire Management Options

Base – No Power

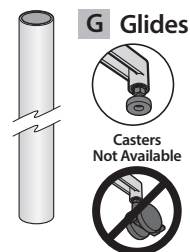

Does not provide access for cord management.

Base – Power Ready

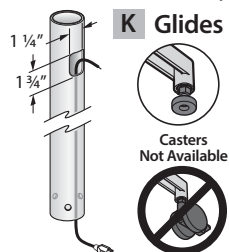

Provides access for cord management through (1) of the Round Column. Power ready leg location determined during installation.

Component Materials/Finishes

COMPONENT NAME		MATERIALS/ FINISHES	
Asymmetrical Pebble Top	Edge Option is applied to all edges.	(L) Laminate – Specify separate top and edge finish colors.	(J) Edgeband
		(W) Wood – Specify a single finish color for top and edge.	(F) Knife (K) Edgeband (U) Knife
Bridge Base	Feet, Bridge Extrusion Columns and Attachment Plates	(A) Painted – The Foot, Bridge Extrusion, Column and Attachment Plate are painted metal, specify base trim color.	(B) Polished – The Foot and Bridge Extrusion is polished aluminum. The Column and Attachment Plate are painted metal, specify base trim color.
		Base Style	

Top Cutout Options

- Power and Data access may be provided by specifying optional factory installed cutouts.
- Cutouts are designed to accommodate separately specified Flip Top Units.

N No Cutout

Center Power Cutout Locations

1-Piece Top – (2) Cutouts

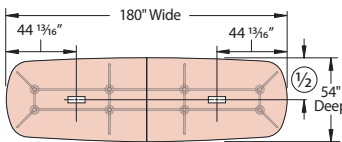

2-Piece Top – (3) Cutouts

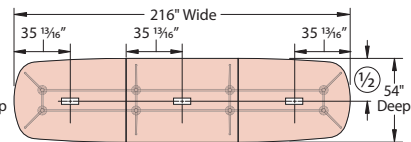

F Center Power Cutout for 4-Port Single Slided Flip Top Unit

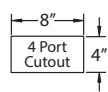

J Center Power Cutout for 6-Port Single Slided Flip Top Unit

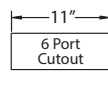

M Center Power Cutout for 8-Port Double Slided Flip Top Unit

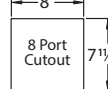

Q Center Power Cutout for 12-Port Double Slided Flip Top Unit

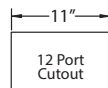

Left/Right Power Cutout Locations

2-Piece Top – (4) Cutouts

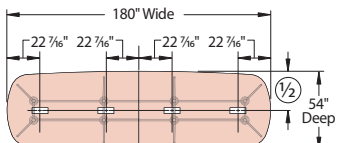

2-Piece Top – (6) Cutouts

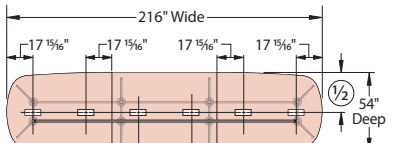

V Left/Right Power Cutout for 4-Port Single Slided Flip Top Unit

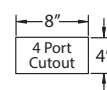

K Left/Right Power Cutout for 6-Port Single Slided Flip Top Unit

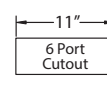

Table Heights

29" High Tables

- Seated applications.
- Specify with standard height seating (17"-18" seat heights).



Product Details – Jive Tables

Bridge Base (8 Columns) – Asymmetrical Pebble (Top)

Sizes and Dimensions

2-Piece Top (180" Wide)

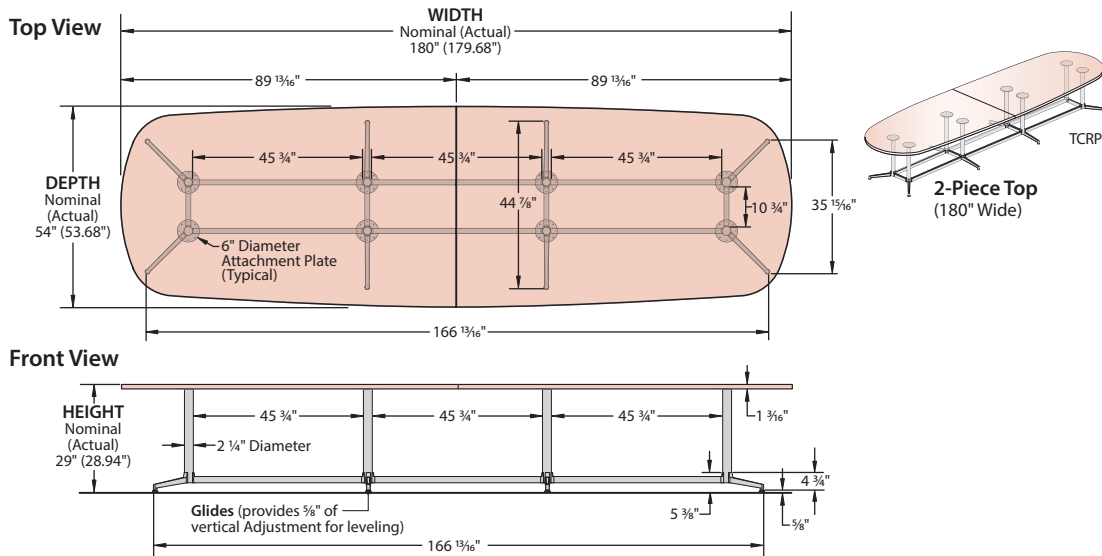

3-Piece Top (216" wide)

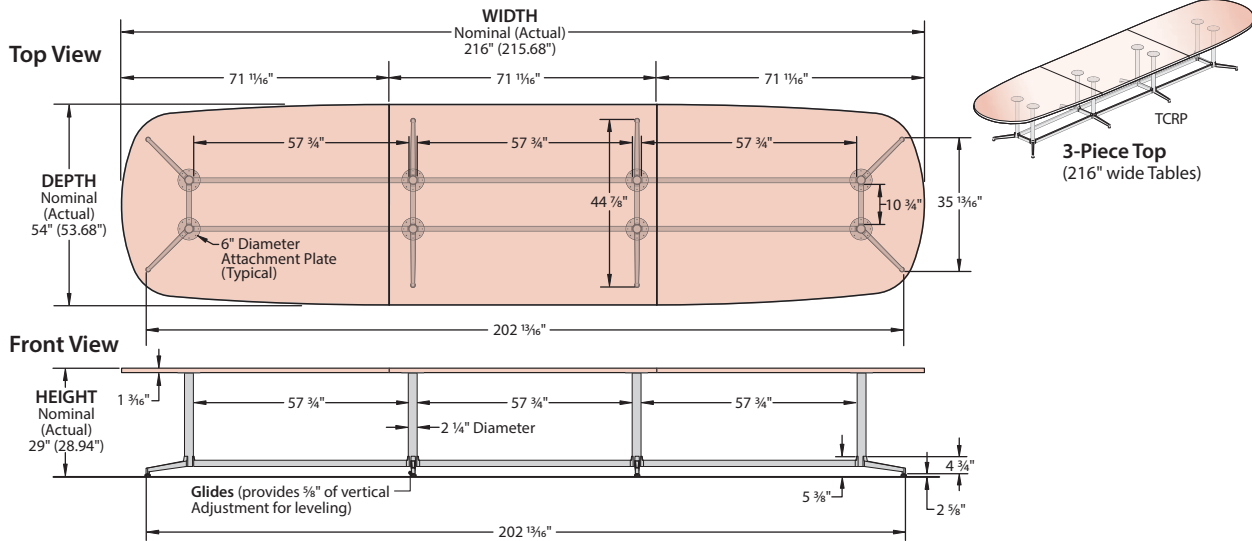

HEIGHT Nominal (Actual)	DEPTH Nominal (Actual)	WIDTH Nominal (Actual)	Number of Columns	Number of Top Pieces	Caster/Glide Availability	
					Casters	Glides
29" (28.94")	54" (53.68")	180" (179.68")	8	2	Yes	Yes
		216" (215.68")	8	3	Yes	Yes

Seating Capacity

Recommended seating capacity based upon a width of 27" per chair.

DEPTH	WIDTH	
	180" Wide	216" Wide
54" Deep	<p>14 Chairs Maximum</p>	<p>16 Chairs Maximum</p>

Product Details – Jive Tables

Bridge Base (2 Columns) – Rectangle (Top)

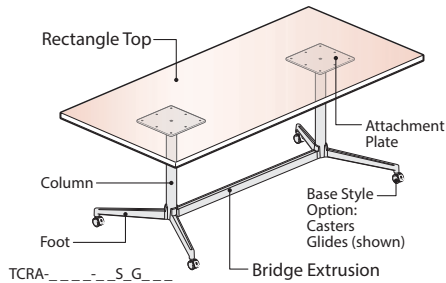

Wood Grain Direction



Top Cutout Options

- Power and Data access may be provided by specifying optional factory installed cutouts.
- Cutouts are designed to accommodate separately specified Flip Top Units.

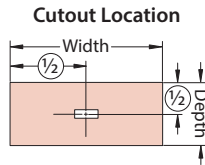

N No Cutout

F Center Power
Cutout for 4-Port Single Sided Flip Top Unit

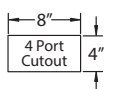

J Center Power
Cutout for 6-Port Single Sided Flip Top Unit

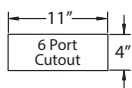

M Center Power
Cutout for 8-Port Double Sided Flip Top Unit

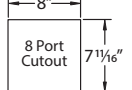

Q Center Power
Cutout for 12-Port Double Sided Flip Top Unit

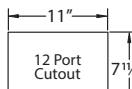

Base & Wire Management Options

Base - No Power

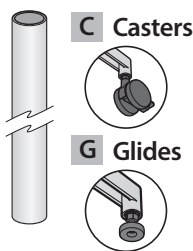

Does not provide access for cord management.

Base - Power Ready

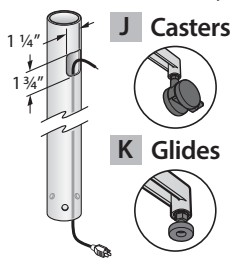

Provides access for cord management through (1) of the Round Column. Power ready leg location determined during installation.

Note Only the 29" and 42" high Tables may be specified with the caster option. All other heights are standard with Glides only.

Component Materials/Finishes

COMPONENT NAME		MATERIALS/ FINISHES	
Rectangle Top	Edge Option is applied to all edges.	(L) Laminate – Specify separate top and edge finish colors.	(J) Edgeband
		(W) Wood – Specify a single finish color for top and edge.	(F) Knife (K) Edgeband (U) Knife
Bridge Base	Feet, Bridge Extrusion Columns and Attachment Plates	(A) Painted – The Foot, Bridge Extrusion, Column and Attachment Plate are painted metal, specify base trim color.	
		(B) Polished – The Foot and Bridge Extrusion is polished aluminum. The Column and Attachment Plate are painted metal, specify base trim color.	
	Base Style	Casters – Standard in black.	
		Glides – Standard in black.	

Sizes and Dimensions

Top View – 2 Column

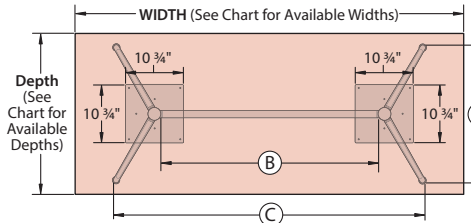

Front View – 2 Column with Glides

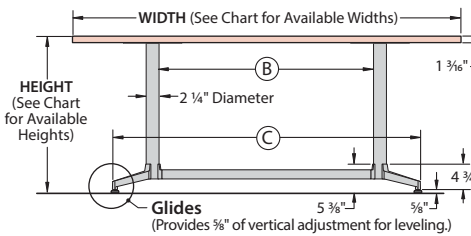

Front View - 2 Column with Casters

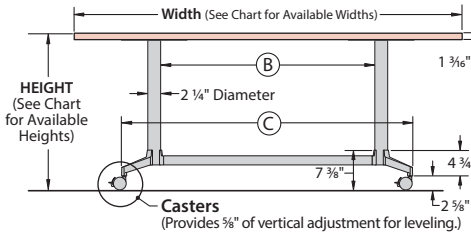
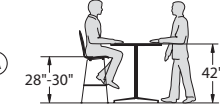

Table Heights

42" High Tables

- Seated or standing applications.
- Specify with bar height stools (28"-30" seat heights).



36" High Tables

- Seated or standing applications.
- Specify with counter height stools (24"-26" seat heights).

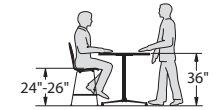

29" High Tables

- Seated applications.
- Specify with standard height seating (17"-18" seat heights).

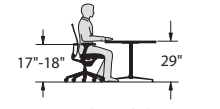

20" High Tables

- Seated or lounge applications.
- Specify with standard/lounge seating (14"-18" seat heights).



16" High Tables

- Seated or lounge applications.
- Specify with standard/lounge seating (14"-18" seat heights).



Seating Capacity

Recommended seating capacity based upon a width of 27" per chair.

Table Height	Table Width	Seating Capacity
30" Deep	48" Wide	(4) Chairs Max.
30" Deep	60" Wide	(6) Chairs Max.
30" Deep	72" Wide	(6) Chairs Max.
36" Deep	60" Wide	(6) Chairs Max.
36" Deep	72" Wide	(6) Chairs Max.

HEIGHT Nominal (Actual)	DEPTH Nominal (Actual)	WIDTH Nominal (Actual)	Component Dimensions			Caster/Glide Availability	
			A	B	C	Casters	Glides
16" (15.94")	30" (29.68")	48" (47.68")	25 1/8"	27 3/4"	44 7/8"	No	Yes
		60" (59.68")	25 1/8"	33 3/4"	50 7/8"	No	Yes
		72" (71.68")	25 1/8"	39 3/4"	56 7/8"	No	Yes
20" (19.94")	30" (29.68")	48" (47.68")	25 1/8"	27 3/4"	44 7/8"	No	Yes
		60" (59.68")	25 1/8"	33 3/4"	50 7/8"	No	Yes
		72" (71.68")	25 1/8"	39 3/4"	56 7/8"	No	Yes
29" (28.94")	30" (29.68")	48" (47.68")	25 1/8"	27 3/4"	44 7/8"	Yes	Yes
		60" (59.68")	25 1/8"	33 3/4"	50 7/8"	Yes	Yes
		72" (71.68")	25 1/8"	39 3/4"	56 7/8"	Yes	Yes
36" (35.94")	30" (29.68")	48" (47.68")	25 1/8"	27 3/4"	44 7/8"	No	Yes
		60" (59.68")	25 1/8"	33 3/4"	50 7/8"	No	Yes
		72" (71.68")	25 1/8"	39 3/4"	56 7/8"	No	Yes
42" (41.94")	30" (29.68")	48" (47.68")	25 1/8"	27 3/4"	44 7/8"	Yes	Yes
		60" (59.68")	25 1/8"	33 3/4"	50 7/8"	Yes	Yes
		72" (71.68")	25 1/8"	39 3/4"	56 7/8"	Yes	Yes

Product Details – Jive Tables

Bridge Base (3 Columns) – Rectangle (Top)

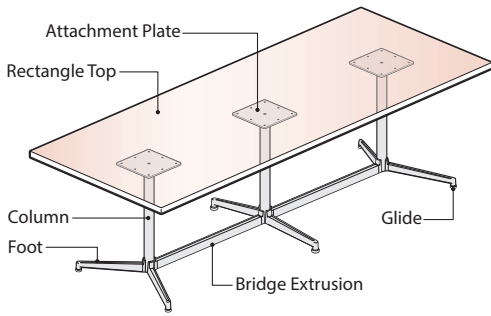

TCRA-____S_G_

Component Materials/Finishes

COMPONENT NAME	MATERIALS/ FINISHES	
Rectangle Top Edge Option is applied to all edges.	(L) Laminate – Specify separate top and edge finish colors.	(J) Edgeband
	(W) Wood – Specify a single finish color for top and edge.	(F) Knife (K) Edgeband (U) Knife
Bridge Base	(A) Painted – The Foot, Bridge Extrusion, Column and Attachment Plate are painted metal, specify base trim color.	
	(B) Polished – The Foot and Bridge Extrusion is polished aluminum. The Column and Attachment Plate are painted metal, specify base trim color.	
Base Style	Glides – Standard in black.	

Wood Grain Direction

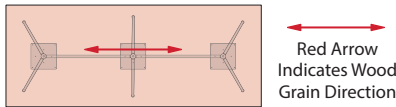

Rectangle (3 Column)

Top Cutout Options

- Power and Data access may be provided by specifying optional factory installed cutouts.
- Cutouts are designed to accommodate separately specified Flip Top Units.

Left/Right Power Cutout Locations

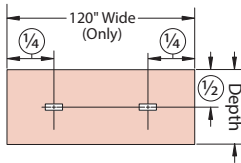

N No Cutout

V Left/Right Power Cutout for 4-Port Single Sided Flip Top Unit

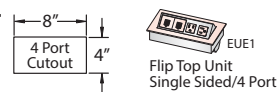

K Left/Right Power Cutout for 6-Port Single Sided Flip Top Unit

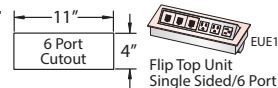

Note 84", 96" and 108" Wide Tables are standard with (N) No Cutout, due to interference with the attachment plates.

Base & Wire Management Options

- The 4 Column Bridge Base is standard with glides only, casters are not available.
- Casters and glides are not interchangeable.

Base - No Power

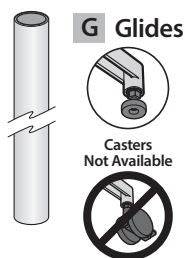

Does not provide access for cord management.

Base - Power Ready

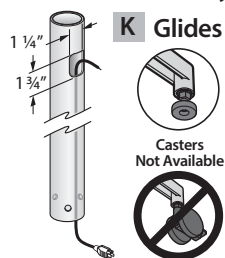

Provides access for cord management through (1) of the Round Column. Power ready leg location determined during installation.

Table Heights

29" High Tables

- Seated applications.
- Specify with standard height seating (17"-18" seat heights).

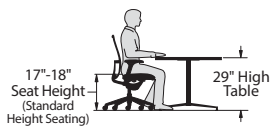

Sizes and Dimensions

Top View – 3 Column

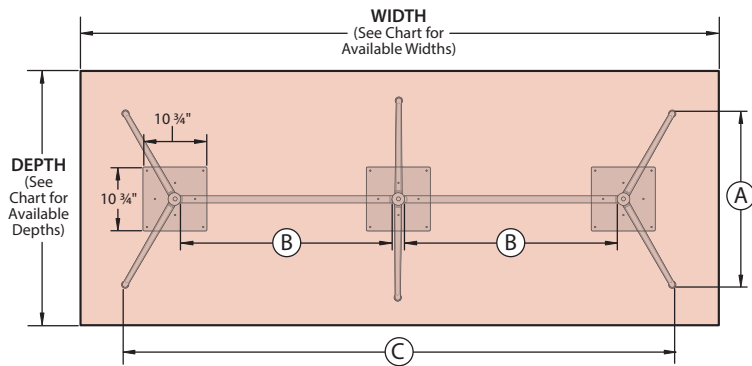

Front View – 3 Column

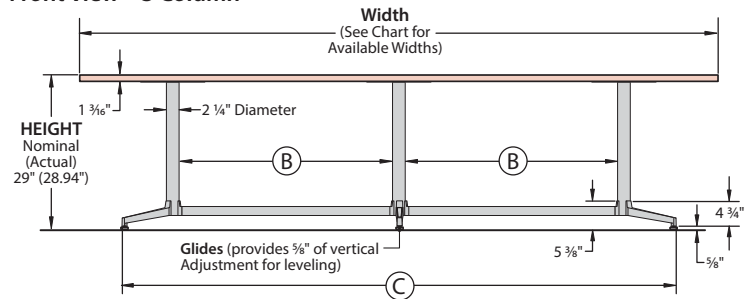

HEIGHT Nominal (Actual)	DEPTH Nominal (Actual)	WIDTH Nominal (Actual)	Number of Columns	Component Dimensions			Caster/Glide Availability	
				A	B	C	Casters	Glides
29" (28.94")	42" (41.68")	84" (83.68")	3	32 1/16"	21 3/4"	67 3/8"	No	Yes
		96" (95.68")	3	32 1/16"	27 3/4"	79 3/8"	No	Yes
	48" (47.68")	96" (95.68")	3	32 1/16"	27 3/4"	79 3/8"	No	Yes
		108" (107.68")	3	32 1/16"	33 3/4"	91 3/8"	No	Yes
		120" (119.68")	3	32 1/16"	39 3/4"	103 3/8"	No	Yes

Seating Capacity

- Recommended seating capacity based upon a width of 27" per chair.

DEPTH	WIDTH			
	84" Wide	96" Wide	108" Wide	120" Wide
42" Deep	6 Chairs Maximum	8 Chairs Maximum	N/A	N/A
48" Deep	N/A	8 Chairs Maximum	10 Chairs Maximum	10 Chairs Maximum

Product Details – Jive Tables

Bridge Base (6 Columns) – Rectangle (Top)

1-Piece Top (96", 108" and 120" wide)

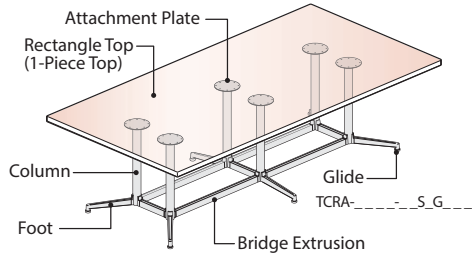

2-Piece Top (144" wide)

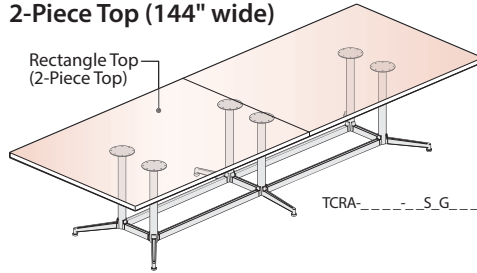

Wood Grain Direction

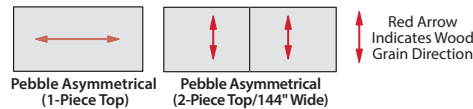
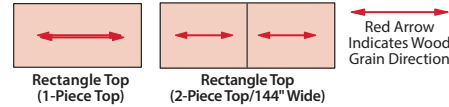
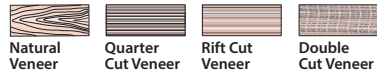

Note When laminate wood grain is specified for multi-piece tops the grain may not match.

Base & Wire Management Options

- The 4 Column Bridge Base is standard with glides only, casters are not available.
- Casters and glides are not interchangeable.

Base - No Power

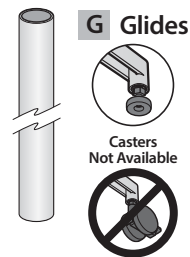

Does not provide access for cord management.

Base - Power Ready

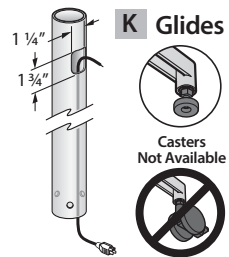

Provides access for cord management through (1) of the Round Column. Power ready leg location determined during installation.

Component Materials/Finishes

COMPONENT NAME		MATERIALS/ FINISHES	
Bridge Base	Rectangle Top Edge Option is applied to all edges.	(L) Laminate – Specify separate top and edge finish colors.	(J) Edgeband
		(W) Wood – Specify a single finish color for top and edge.	(F) Knife (K) Edgeband (U) Knife
Bridge Base	Feet, Bridge Extrusion, Columns and Attachment Plates	(A) Painted – The Foot, Bridge Extrusion, Column and Attachment Plate are painted metal, specify base trim color.	
		(B) Polished – The Foot and Bridge Extrusion is polished aluminum. The Column and Attachment Plate are painted metal, specify base trim color.	
	Base Style	Glides – Standard in black.	

Top Cutout Options

- Power and Data access may be provided by specifying optional factory installed cutouts.
- Cutouts are designed to accommodate separately specified Flip Top Units.

N No Cutout

Center Power Cutout Locations

1-Piece Top – (1) Cutout

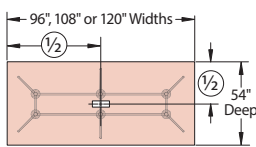

F Center Power
Cutout for 4-Port Single Sided Flip Top Unit

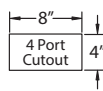

2-Piece Top – (2) Cutouts

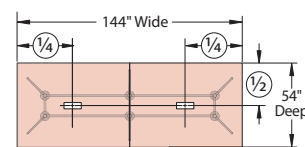

J Center Power
Cutout for 6-Port Single Sided Flip Top Unit

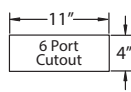

M Center Power
Cutout for 8-Port Double Sided Flip Top Unit

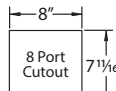

Q Center Power
Cutout for 12-Port Double Sided Flip Top Unit

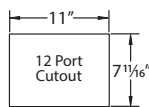

V Left/Right Power
Cutout for 4-Port Single Sided Flip Top Unit

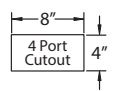

K Left/Right Power
Cutout for 6-Port Single Sided Flip Top Unit

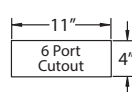

V Left/Right Power
Cutout for 4-Port Single Sided Flip Top Unit

Left/Right Power Cutout Locations

1-Piece Top – (2) Cutouts

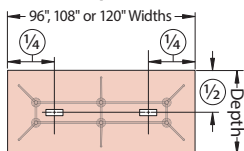

V Left/Right Power
Cutout for 4-Port Single Sided Flip Top Unit

K Left/Right Power
Cutout for 6-Port Single Sided Flip Top Unit

2-Piece Top – (4) Cutouts

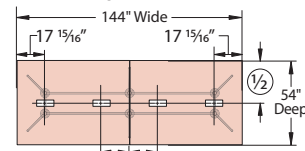

V Left/Right Power
Cutout for 4-Port Single Sided Flip Top Unit

K Left/Right Power
Cutout for 6-Port Single Sided Flip Top Unit

Table Heights

29" High Tables

- Seated applications.
- Specify with standard height seating (17"-18" seat heights).



Product Details – Jive Tables

Bridge Base (6 Columns) – Rectangle (Top)

Sizes and Dimensions

1-Piece Top (96", 108" and 120" wide)

Top View

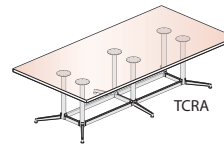
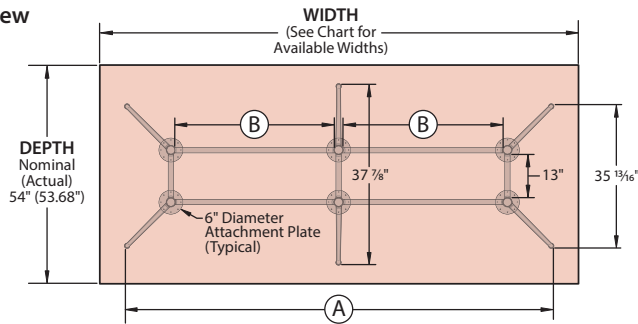

1-Piece Top
(96", 108" and
120" wide Tables)

Front View

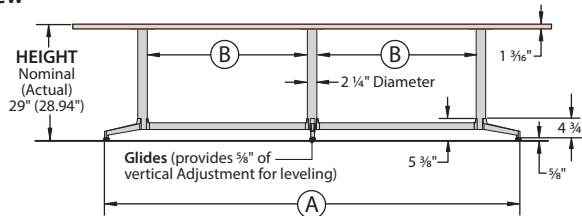

2-Piece Top (144" wide)

Top View

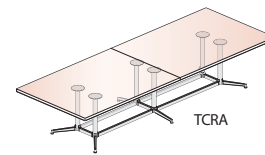
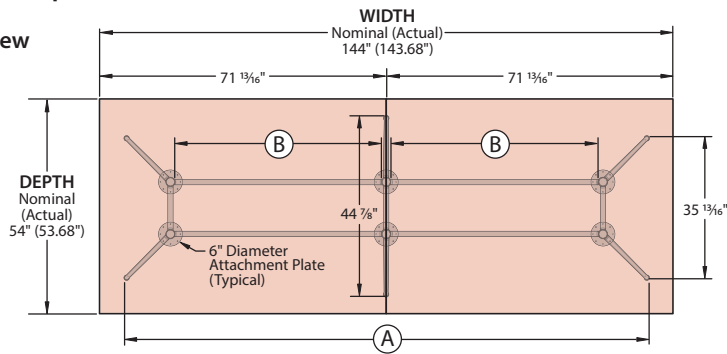

2-Piece Top
(144" wide Tables)

Front View

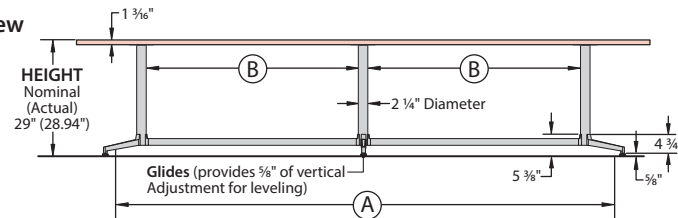

HEIGHT Nominal (Actual)	DEPTH Nominal (Actual)	WIDTH Nominal (Actual)	Number of Columns	Number of Top Pieces	Component Dimensions		Caster/Glide Availability	
					A	B	Casters	Glides
29" (28.94")	54" (53.68")	96" (95.68")	6	1	82 13/16"	27 3/4"	No	Yes
		108" (107.68")	6	1	94 13/16"	33 3/4"	No	Yes
		120" (119.68")	6	1	106 13/16"	39 3/4"	No	Yes
		144" (143.68")	6	2	118 13/16"	45 3/4"	No	Yes

Seating Capacity

Recommended seating capacity based upon a width of 27" per chair.

DEPTH	WIDTH			
	96" Wide	108" Wide	120" Wide	144" Wide
54" Deep	 10 Chairs Maximum	 12 Chairs Maximum	 12 Chairs Maximum	 14 Chairs Maximum

Product Details – Jive Tables

Bridge Base (8 Columns) – Rectangle (Top)

2-Piece Top (180" wide)

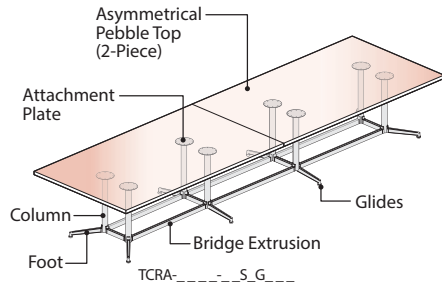

3-Piece Top (216" wide)

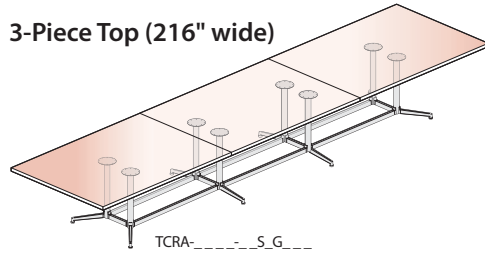

Wood Grain Direction

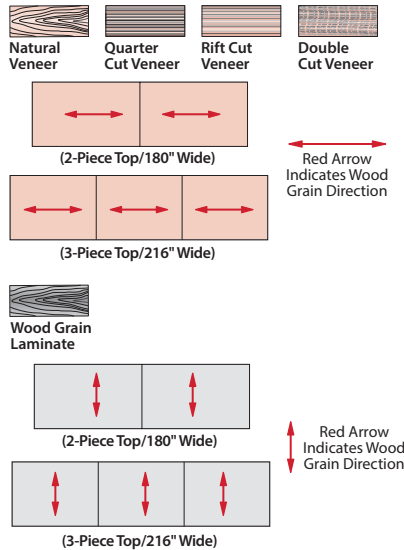

Note When laminate wood grain is specified for multi-piece tops the grain may not match.

Base & Wire Management Options

- The 4 Column Bridge Base is standard with glides only, casters are not available.
- Casters and glides are not interchangeable.

Base - No Power

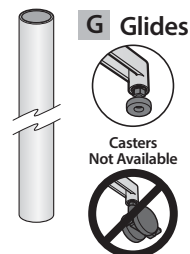

Does not provide access for cord management.

Base - Power Ready

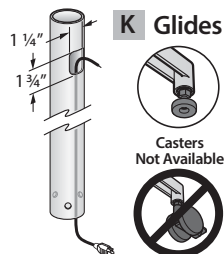

Provides access for cord management through (1) of the Round Column. Power ready leg location determined during installation.

Component Materials/Finishes

COMPONENT NAME		MATERIALS/ FINISHES	
Rectangle Top	Edge Option is applied to all edges.	(L) Laminate – Specify separate top and edge finish colors.	(J) Edgeband
		(W) Wood – Specify a single finish color for top and edge.	(F) Knife (K) Edgeband (U) Knife
Bridge Base	Feet, Bridge Extrusion Columns and Attachment Plates	(A) Painted – The Foot, Bridge Extrusion, Column and Attachment Plate are painted metal, specify base trim color.	(B) Polished – The Foot and Bridge Extrusion is polished aluminum. The Column and Attachment Plate are painted metal, specify base trim color.
		Glides – Standard in black.	
	Base Style		

Top Cutout Options

- Power and Data access may be provided by specifying optional factory installed cutouts.
- Cutouts are designed to accommodate separately specified Flip Top Units.

N No Cutout

Center Power Cutout Locations

1-Piece Top – (2) Cutouts

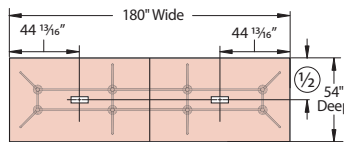

2-Piece Top – (3) Cutouts

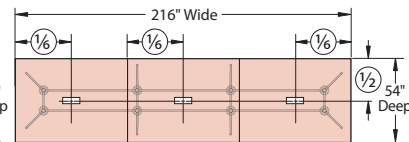

F Center Power

Cutout for 4-Port Single Sided Flip Top Unit

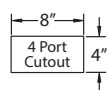

J Center Power

Cutout for 6-Port Single Sided Flip Top Unit

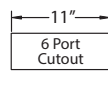

M Center Power

Cutout for 8-Port Double Sided Flip Top Unit

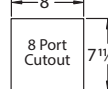

Q Center Power

Cutout for 12-Port Double Sided Flip Top Unit

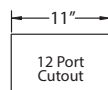

Left/Right Power Cutout Locations

2-Piece Top – (4) Cutouts

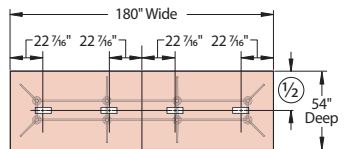

2-Piece Top – (6) Cutouts

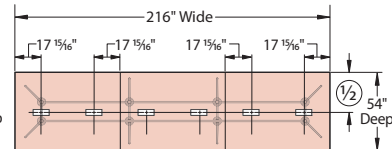

V Left/Right Power

Cutout for 4-Port Single Sided Flip Top Unit

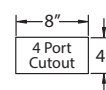

K Left/Right Power

Cutout for 6-Port Single Sided Flip Top Unit

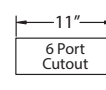

Table Heights

29" High Tables

- Seated applications.
- Specify with standard height seating (17"-18" seat heights).



Product Details – Jive Tables

Bridge Base (8 Columns) – Asymmetrical Pebble (Top)

Sizes and Dimensions

2-Piece Top (180" Wide)

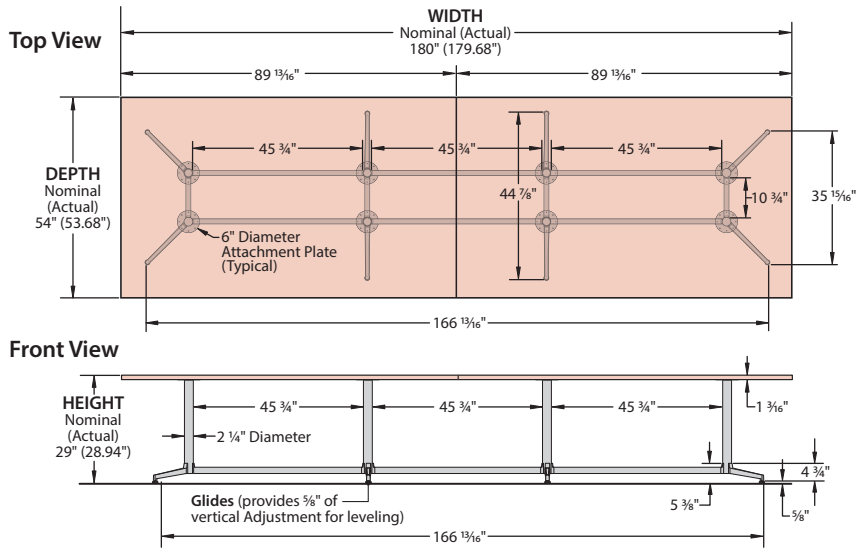

3-Piece Top (216" wide)

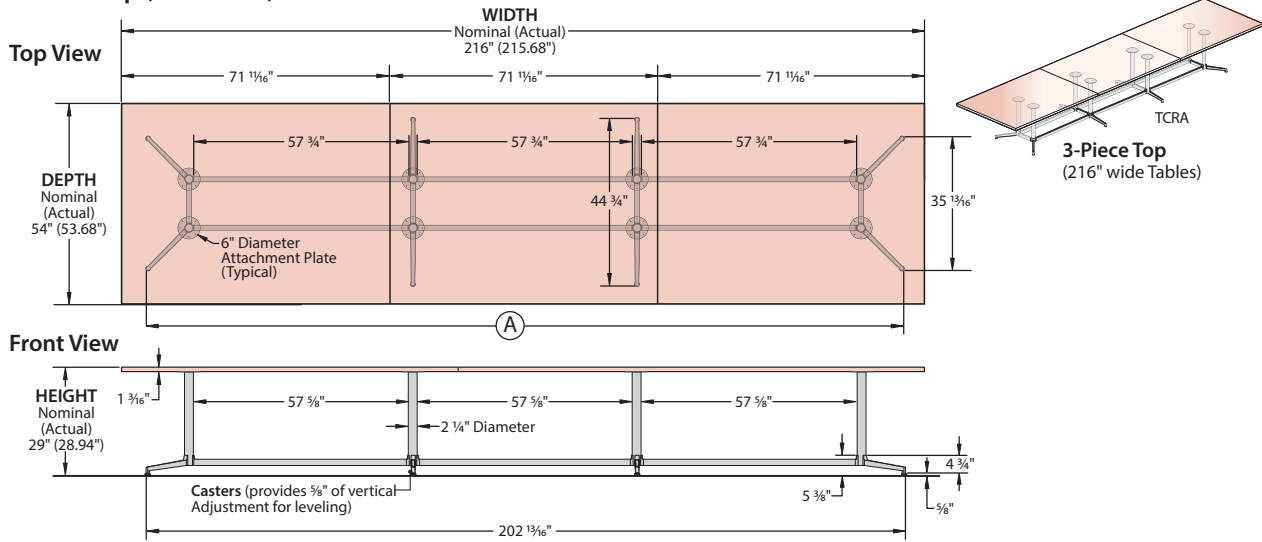

HEIGHT Nominal (Actual)	DEPTH Nominal (Actual)	WIDTH Nominal (Actual)	Number of Columns	Number of Top Pieces	Caster/Glide Availability	
					Casters	Glides
29" (28.94")	54" (53.68")	180" (179.68")	8	2	Yes	Yes
		216" (215.68")	8	3	Yes	Yes

Seating Capacity

Recommended seating capacity based upon a width of 27" per chair.

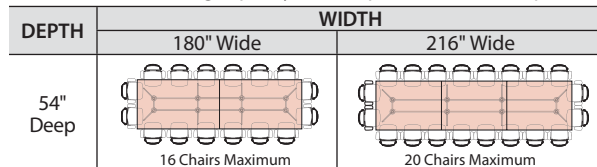

Product Details – Jive Tables

Bridge Base (2 Columns) – Asymmetrical Pebble (Top)

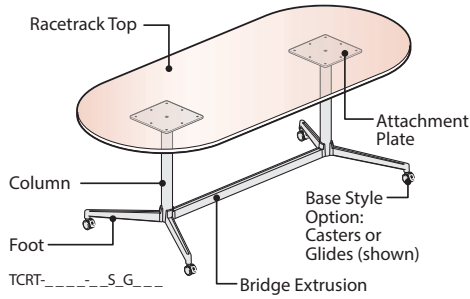

Wood Grain Direction

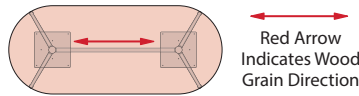

Top Cutout Options

- Power and Data access may be provided by specifying optional factory installed cutouts.
- Cutouts are designed to accommodate separately specified Flip Top Units.

Center Power Cutout Location

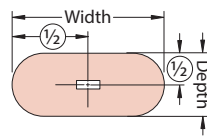

N No Cutout

F Center Power
Cutout for 4-Port Single Sided Flip Top Unit

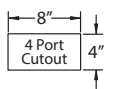

J Center Power
Cutout for 6-Port Single Sided Flip Top Unit

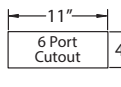

M Center Power
Cutout for 8-Port Double Sided Flip Top Unit

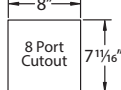

Q Center Power
Cutout for 12-Port Double Sided Flip Top Unit

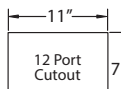

Base & Wire Management Options

Base - No Power

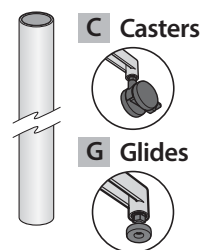

Does not provide access for cord management.

Base - Power Ready

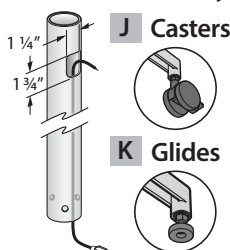

Provides access for cord management through (1) of the Round Column. Power ready leg location determined during installation.

Note Only the 29" and 42" high Tables may be specified with the caster option. All other heights are standard with Glides only.

Component Materials/Finishes

COMPONENT NAME		MATERIALS/ FINISHES	
Round Top Edge Option is applied to all edges.		(L) Laminate – Specify separate top and edge finish colors.	(J) Edgeband
		(W) Wood – Specify a single finish color for top and edge.	(F) Knife (K) Edgeband (U) Knife
Bridge Base	Feet, Bridge Extrusion Columns and Attachment Plates	(A) Painted – The Foot, Bridge Extrusion, Column and Attachment Plate are painted metal, specify base trim color.	
	Base Style	(B) Polished – The Foot and Bridge Extrusion is polished aluminum. The Column and Attachment Plate are painted metal, specify base trim color.	
		Casters – Standard in black.	
		Glides – Standard in black.	

Sizes and Dimensions

Top View – 2 Column

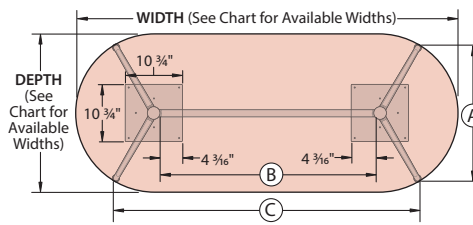

Front View – 2 Column with Glides

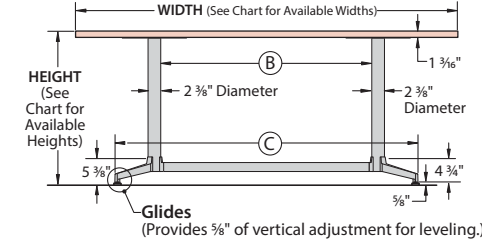

Front View – 2 Column with Casters

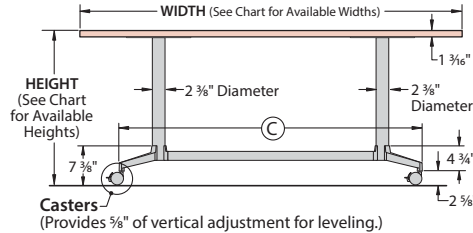

Table Heights

42" High Tables
• Seated or standing applications.
• Specify with bar height stools (28"-30" seat heights).



36" High Tables
• Seated or standing applications.
• Specify with counter height stools (24"-26" seat heights).



29" High Tables
• Seated applications.
• Specify with standard height seating (17"-18" seat heights).

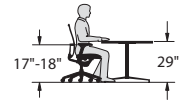

20" High Tables
• Seated or lounge applications.
• Specify with standard/lounge seating (14"-18" seat heights).



16" High Tables
• Seated or lounge applications.
• Specify with standard/lounge seating (14"-18" seat heights).



Seating Capacity

Recommended seating capacity based upon a width of 27" per chair.

Table Height	Table Width	Seating Capacity
30" Deep	48" Wide	(4) Chairs Max.
30" Deep	60" Wide	(6) Chairs Max.
30" Deep	72" Wide	(6) Chairs Max.
36" Deep	60" Wide	(6) Chairs Max.
36" Deep	72" Wide	(6) Chairs Max.

HEIGHT Nominal (Actual)	DEPTH Nominal (Actual)	WIDTH Nominal (Actual)	Component Dimensions			Caster/Glide Availability	
			A	B	C	Casters	Glides
16" (15.94")	30" (29.68")	48" (47.68")	25 1/8"	15 3/4"	35 3/8"	No	Yes
	60" (59.68")	72" (71.68")	25 1/8"	27 3/4"	41 1/8"	No	Yes
	36" (35.68")	60" (59.68")	27 3/4"	27 3/4"	46 7/8"	No	Yes
	72" (71.68")	27 3/4"	33 3/4"	52 3/8"	No	Yes	
20" (19.94")	30" (29.68")	48" (47.68")	25 1/8"	15 3/4"	35 3/8"	No	Yes
	60" (59.68")	72" (71.68")	25 1/8"	27 3/4"	41 1/8"	No	Yes
	36" (35.68")	60" (59.68")	27 3/4"	27 3/4"	46 7/8"	No	Yes
	72" (71.68")	27 3/4"	33 3/4"	52 3/8"	No	Yes	
29" (28.94")	30" (29.68")	48" (47.68")	25 1/8"	15 3/4"	35 3/8"	Yes	Yes
	60" (59.68")	72" (71.68")	25 1/8"	27 3/4"	41 1/8"	Yes	Yes
	36" (35.68")	60" (59.68")	27 3/4"	27 3/4"	46 7/8"	Yes	Yes
	72" (71.68")	27 3/4"	33 3/4"	52 3/8"	Yes	Yes	
36" (35.94")	30" (29.68")	48" (47.68")	25 1/8"	15 3/4"	35 3/8"	No	Yes
	60" (59.68")	72" (71.68")	25 1/8"	27 3/4"	41 1/8"	No	Yes
	36" (35.68")	60" (59.68")	27 3/4"	27 3/4"	46 7/8"	No	Yes
	72" (71.68")	27 3/4"	33 3/4"	52 3/8"	No	Yes	
42" (41.94")	30" (29.68")	48" (47.68")	25 1/8"	15 3/4"	35 3/8"	Yes	Yes
	60" (59.68")	72" (71.68")	25 1/8"	27 3/4"	41 1/8"	Yes	Yes
	36" (35.68")	60" (59.68")	27 3/4"	27 3/4"	46 7/8"	Yes	Yes
	72" (71.68")	27 3/4"	33 3/4"	52 3/8"	Yes	Yes	

Product Details – Jive Tables

Bridge Base (3 Columns) – Racetrack (Top)

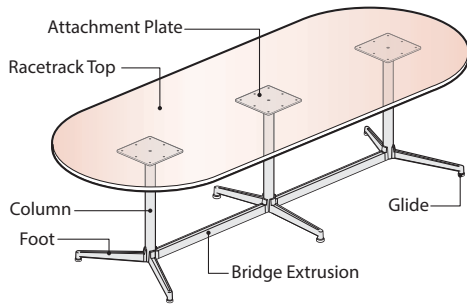

TCRT_..._S_G_...

Component Materials/Finishes

COMPONENT NAME	MATERIALS/ FINISHES	
Racetrack Top Edge Option is applied to all edges.	(L) Laminate – Specify separate top and edge finish colors.	(J) Edgeband
	(W) Wood – Specify a single finish color for top and edge.	(F) Knife (K) Edgeband (U) Knife
Bridge Base	(A) Painted – The Foot, Bridge Extrusion, Column and Attachment Plate are painted metal, specify base trim color.	
	(B) Polished – The Foot and Bridge Extrusion is polished aluminum. The Column and Attachment Plate are painted metal, specify base trim color.	
Base Style	Glides – Standard in black.	

Wood Grain Direction

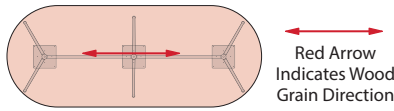

Top Cutout Options

- Power and Data access may be provided by specifying optional factory installed cutouts.
- Cutouts are designed to accommodate separately specified Flip Top Units.

Left/Right Power Cutout Locations

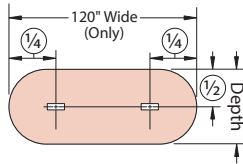

N No Cutout

V Left/Right Power

Cutout for 4-Port Single Sided Flip Top Unit

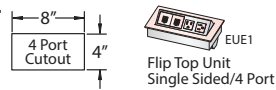

K Left/Right Power

Cutout for 6-Port Single Sided Flip Top Unit

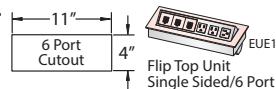

Note 84", 96" and 108" Wide Tables are standard with (N) No Cutout, due to interference with the attachment plates.

Sizes and Dimensions

Top View – 3 Column

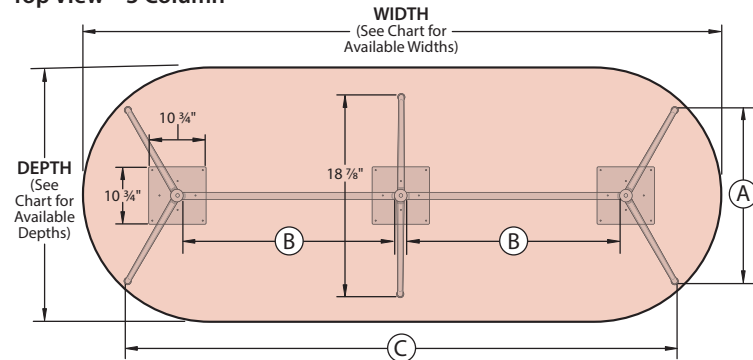

Front View – 3 Column

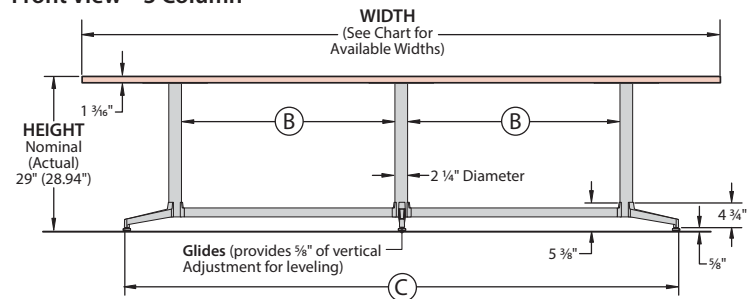

Base & Wire Management Options

- The 4 Column Bridge Base is standard with glides only, casters are not available.
- Casters and glides are not interchangeable.

Base - No Power

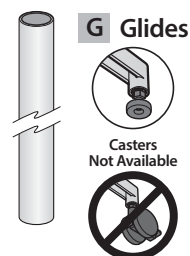

Does not provide access for cord management.

Base - Power Ready

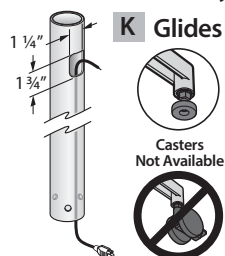

Provides access for cord management through (1) of the Round Column. Power ready leg location determined during installation.

HEIGHT Nominal (Actual)	DEPTH Nominal (Actual)	WIDTH Nominal (Actual)	Number of Columns	Component Dimensions			Caster/Glide Availability	
				A	B	C	Casters	Glides
29" (28.94")	42" (41.68")	84" (83.68")	3	32 1/16"	21 3/4"	67 3/8"	No	Yes
		96" (95.68")	3	32 1/16"	27 3/4"	79 3/8"	No	Yes
	48" (47.68")	96" (95.68")	3	32 1/16"	27 3/4"	79 3/8"	No	Yes
		108" (107.68")	3	32 1/16"	33 3/4"	91 3/8"	No	Yes
		120" (119.68")	3	32 1/16"	39 3/4"	103 3/8"	No	Yes

Seating Capacity

- Recommended seating capacity based upon a width of 27" per chair.

DEPTH	WIDTH			
	84" Wide	96" Wide	108" Wide	120" Wide
42" Deep	6 Chairs Maximum	8 Chairs Maximum	N/A	N/A
48" Deep	N/A	N/A	10 Chairs Maximum	10 Chairs Maximum

Table Heights

29" High Tables

- Seated applications.
- Specify with standard height seating (17"-18" seat heights).



Product Details – Jive Tables

Bridge Base (6 Columns) – Racetrack (Top)

1-Piece Top (96", 108" and 120" wide)

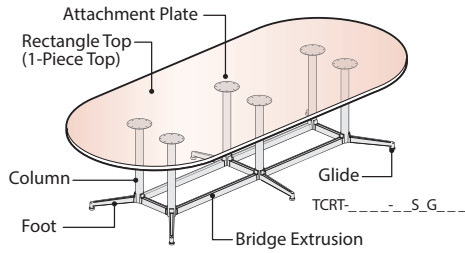

2-Piece Top (144" wide)

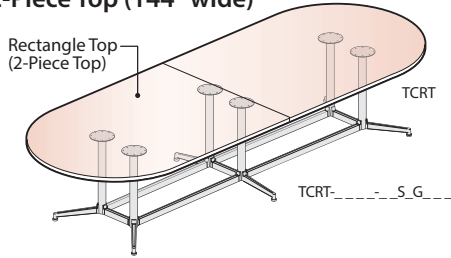

Wood Grain Direction

Wood Grain Direction for One-Piece Tops

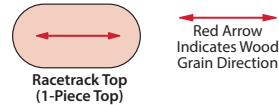
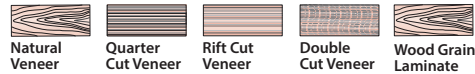

Wood Grain Direction for Two-Piece Tops

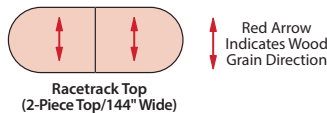
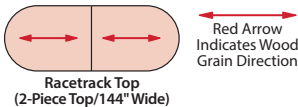
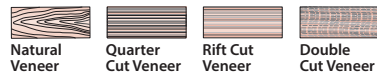

Base & Wire Management Options

- The 4 Column Bridge Base is standard with glides only, casters are not available.
- Casters and glides are not interchangeable.

Base - No Power

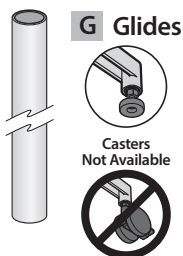

Does not provide access for cord management.

Base - Power Ready

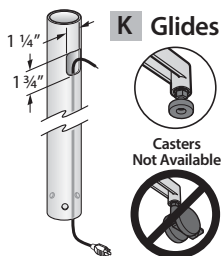

Provides access for cord management through (1) of the Round Column. Power ready leg location determined during installation.

Component Materials/Finishes

COMPONENT NAME		MATERIALS/ FINISHES	
Racetrack Top	Edge Option is applied to all edges.	(L) Laminate – Specify separate top and edge finish colors.	(J) Edgeband
		(W) Wood – Specify a single finish color for top and edge.	(K) Edgeband (U) Knife
Bridge Base	Feet, Bridge Extrusion, Columns and Attachment Plates	(A) Painted – The Foot, Bridge Extrusion, Column and Attachment Plate are painted metal, specify base trim color.	
		(B) Polished – The Foot and Bridge Extrusion is polished aluminum. The Column and Attachment Plate are painted metal, specify base trim color.	
	Base Style	Glides – Standard in black.	

Top Cutout Options

- Power and Data access may be provided by specifying optional factory installed cutouts.
- Cutouts are designed to accommodate separately specified Flip Top Units.

N No Cutout

Center Power Cutout Locations

1-Piece Top – (1) Cutout

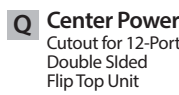
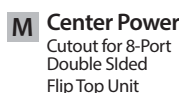
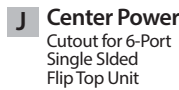
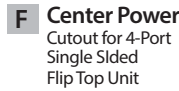
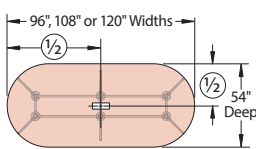

2-Piece Top – (2) Cutouts

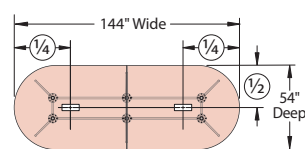

Left/Right Power Cutout Locations

1-Piece Top – (2) Cutouts

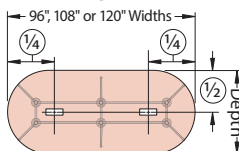

2-Piece Top – (4) Cutouts

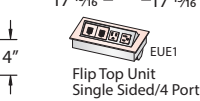
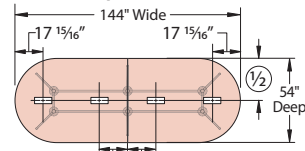

Table Heights

29" High Tables

- Seated applications.
- Specify with standard height seating (17"-18" seat heights).



Product Details – Jive Tables

Bridge Base (6 Columns) – Racetrack (Top)

Sizes and Dimensions

1-Piece Top (96", 108" and 120" wide)

Top View

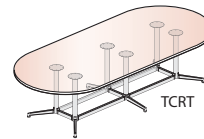
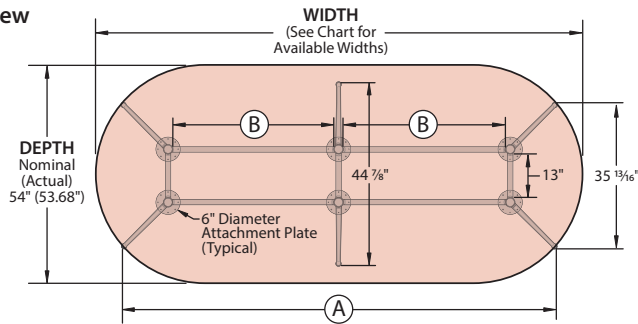

1-Piece Top
(96", 108" and
120" wide Tables)

Front View

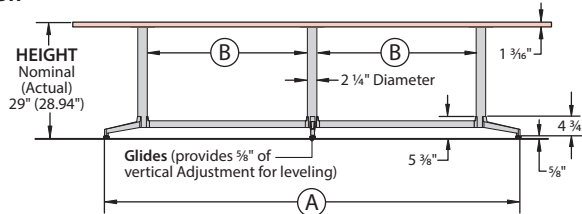

2-Piece Top (144" wide)

Top View

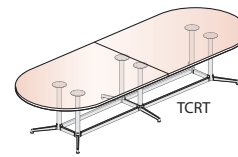
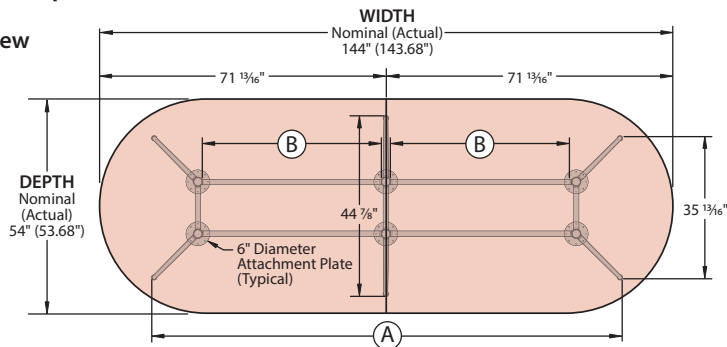

2-Piece Top
(144" wide Tables)

Front View

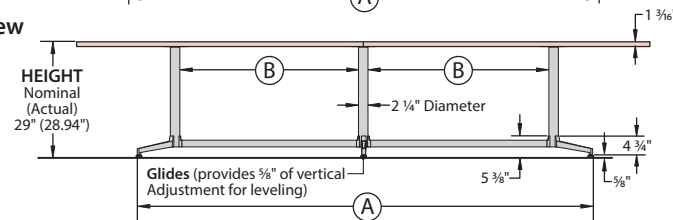

HEIGHT Nominal (Actual)	DEPTH Nominal (Actual)	WIDTH Nominal (Actual)	Number of Columns	Number of Top Pieces	Component Dimensions		Caster/Glide Availability	
					A	B	Casters	Glides
29" (28.94")	54" (53.68")	96" (95.68")	6	1	82 13/16"	27 3/4"	No	Yes
		108" (107.68")	6	1	94 13/16"	33 3/4"	No	Yes
		120" (119.68")	6	1	106 13/16"	39 3/4"	No	Yes
		144" (143.68")	6	2	118 13/16"	45 3/4"	No	Yes

Seating Capacity

• Recommended seating capacity based upon a width of 27" per chair.

DEPTH	WIDTH			
	96" Wide	108" Wide	120" Wide	144" Wide
54" Deep	10 Chairs Maximum	10 Chairs Maximum	10 Chairs Maximum	12 Chairs Maximum

Product Details – Jive Tables

Bridge Base (8 Columns) – Racetrack (Top)

2-Piece Top (180" wide)

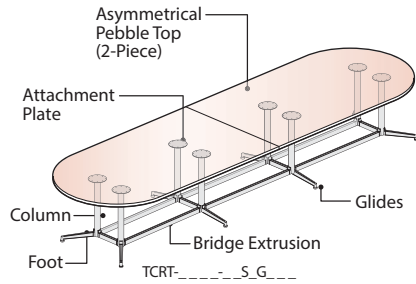

3-Piece Top (216" wide)

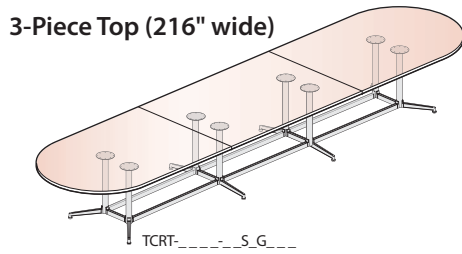

Wood Grain Direction

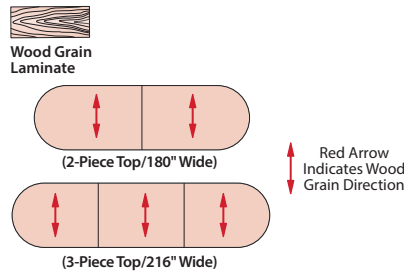
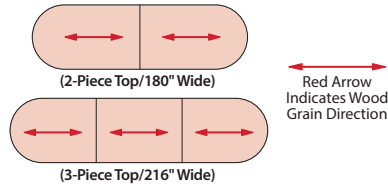
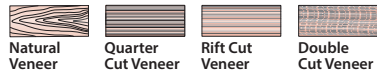

Note When laminate wood grain is specified for multi-piece tops the grain may not match.

Base & Wire Management Options

- The 4 Column Bridge Base is standard with glides only, casters are not available.
- Casters and glides are not interchangeable.

Base - No Power

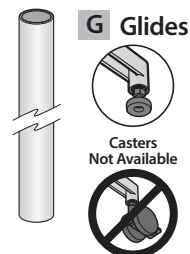

Does not provide access for cord management.

Base - Power Ready

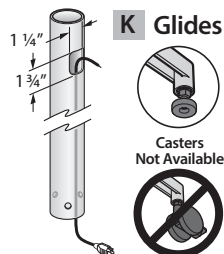

Provides access for cord management through (1) of the Round Column. Power ready leg location determined during installation.

Component Materials/Finishes

COMPONENT NAME		MATERIALS/ FINISHES	
Racetrack Top	Edge Option is applied to all edges.	(L) Laminate – Specify separate top and edge finish colors.	(J) Edgeband
		(W) Wood – Specify a single finish color for top and edge.	(F) Knife (K) Edgeband (U) Knife
Bridge Base	Feet, Bridge Extrusion Columns and Attachment Plates	(A) Painted – The Foot, Bridge Extrusion, Column and Attachment Plate are painted metal, specify base trim color.	(B) Polished – The Foot and Bridge Extrusion is polished aluminum. The Column and Attachment Plate are painted metal, specify base trim color.
		Base Style	

Top Cutout Options

- Power and Data access may be provided by specifying optional factory installed cutouts.
- Cutouts are designed to accommodate separately specified Flip Top Units.

N No Cutout

Center Power Cutout Locations

1-Piece Top – (2) Cutouts

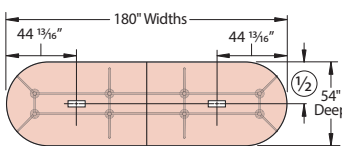

2-Piece Top – (3) Cutouts

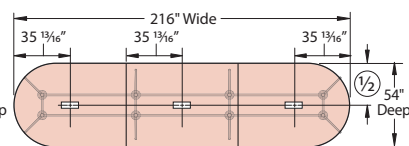

F Center Power Cutout for 4-Port Single Sided Flip Top Unit

EUE1 Flip Top Unit Single Sided/4 Port

J Center Power Cutout for 6-Port Single Sided Flip Top Unit

EUE1 Flip Top Unit Single Sided/6 Port

M Center Power Cutout for 8-Port Double Sided Flip Top Unit

EUE2 Flip Top Unit Double Sided/8 Port

Q Center Power Cutout for 12-Port Double Sided Flip Top Unit

EUE2 Flip Top Unit Double Sided/12 Port

Left/Right Power Cutout Locations

2-Piece Top – (4) Cutouts

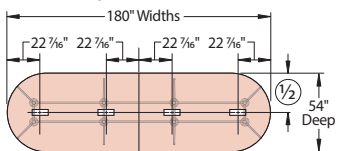

2-Piece Top – (6) Cutouts

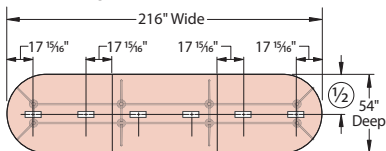

V Left/Right Power Cutout for 4-Port Single Sided Flip Top Unit

EUE1 Flip Top Unit Single Sided/4 Port

K Left/Right Power Cutout for 6-Port Single Sided Flip Top Unit

EUE1 Flip Top Unit Single Sided/6 Port

Table Heights

29" High Tables

- Seated applications.
- Specify with standard height seating (17"-18" seat heights).



Product Details – Jive Tables

Bridge Base (8 Columns) – Asymmetrical Pebble (Top)

Sizes and Dimensions

2-Piece Top (180" Wide)

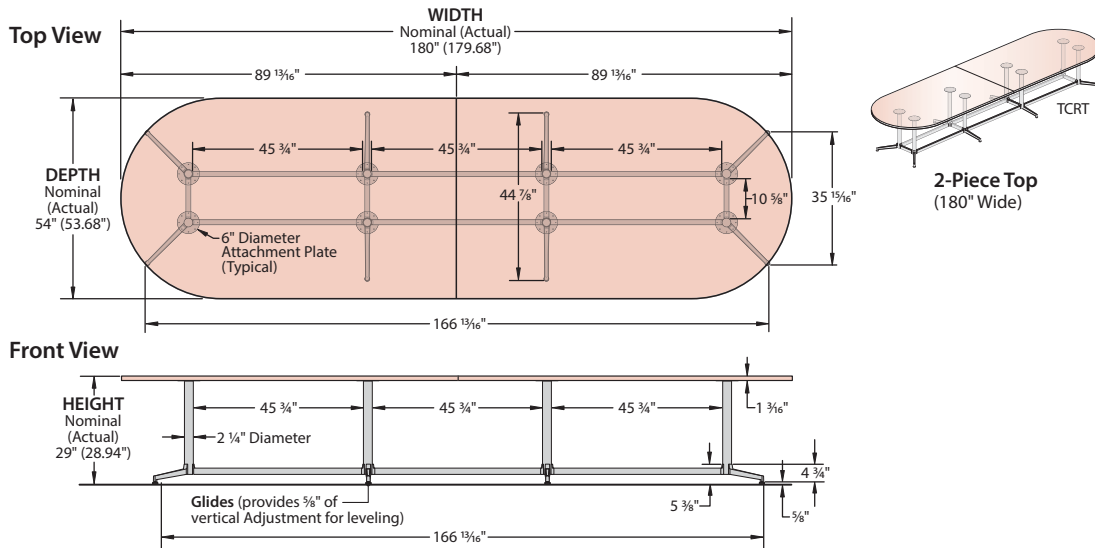

3-Piece Top (216" wide)

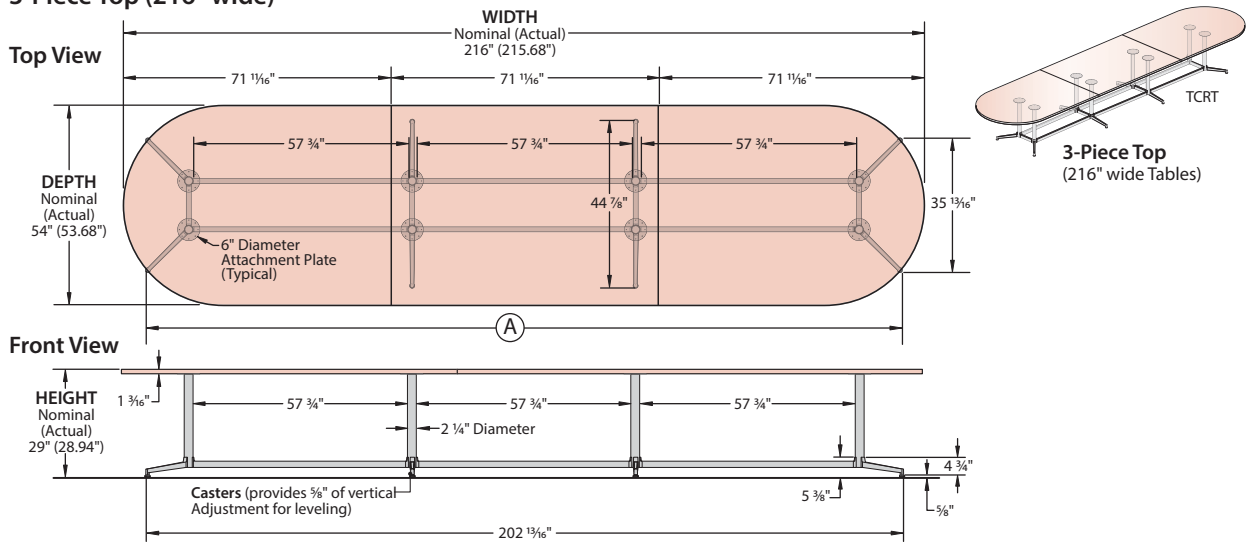

HEIGHT Nominal (Actual)	DEPTH Nominal (Actual)	WIDTH Nominal (Actual)	Number of Columns	Number of Top Pieces	Caster/Glide Availability	
					Casters	Glides
29" (28.94")	54" (53.68")	180" (179.68")	8	2	Yes	Yes
		216" (215.68")	8	3	Yes	Yes

Seating Capacity

Recommended seating capacity based upon a width of 27" per chair.

DEPTH	WIDTH	
	180" Wide	216" Wide
54" Deep	<p>16 Chairs Maximum</p>	<p>18 Chairs Maximum</p>

Product Details – Jive Tables

Bridge Base (2 Column) – Half Racetrack (Top)

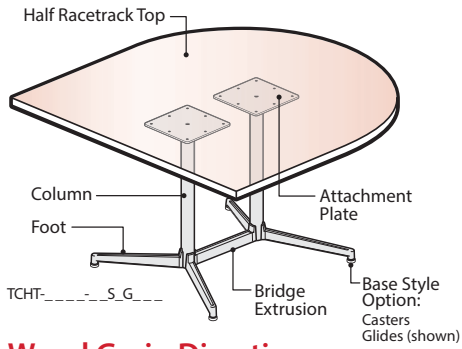

Wood Grain Direction

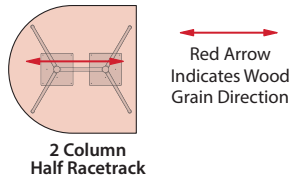

Base & Wire Management Options

Base - No Power

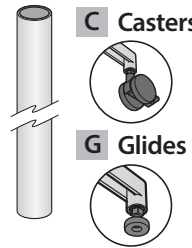

Does not provide access for cord management.

Base - Power Ready

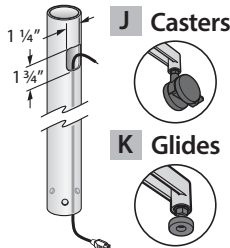

Provides access for cord management through (1) of the Round Column. Power ready leg location determined during installation.

Table Heights

42" High Tables

- Seated or standing applications.
- Specify with bar height stools (28"-30" seat heights).

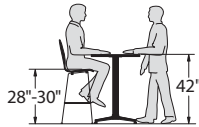

29" High Tables

- Seated applications.
- Specify with standard height seating (17"-18" seat heights).



Seating Capacity

- Recommended seating capacity based upon a width of 27" per chair.

WIDTH/DEPTH	
42" Wide/ 36" Deep	48" Wide/48" Deep
4 Chairs Maximum	5 Chairs Maximum

Component Materials/Finishes

COMPONENT NAME	MATERIALS/ FINISHES	
Half Racetrack Top Edge Option is applied to all edges.	(L) Laminate – Specify separate top and edge finish colors.	(J) Edgeband
	(W) Wood – Specify a single finish color for top and edge.	(F) Knife (K) Edgeband (U) Knife
Bridge Base	(A) Painted – The Foot, Bridge Extrusion, Column and Attachment Plate are painted metal, specify base trim color.	
	(B) Polished – The Foot and Bridge Extrusion is polished aluminum. Column and Attachment Plate are painted metal, specify base trim color.	
Base Style	Casters – Standard in black.	
	Glides – Standard in black.	

Sizes and Dimensions

Top View – 2 Column

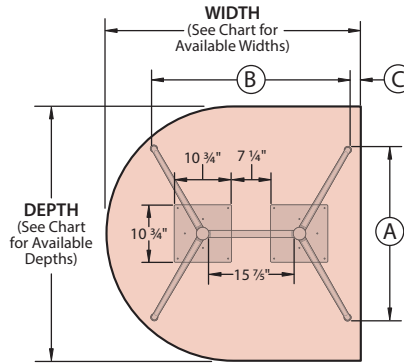

Front View – 2 Column with Glides

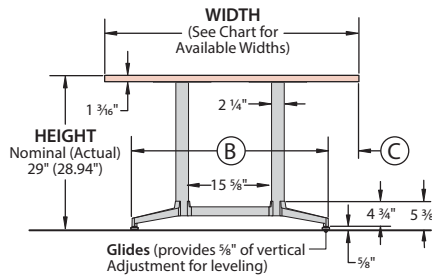

Front View – 2 Column with Casters

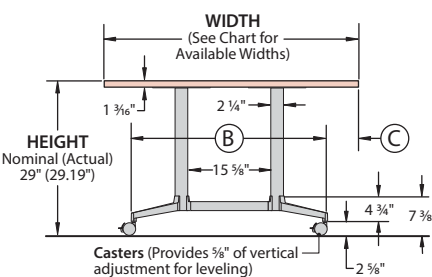

HEIGHT Nominal (Actual)	DEPTH Nominal (Actual)	WIDTH Nominal (Actual)	Number of Columns	Component Dimensions			Caster/Glide Availability	
				A	B	C	Casters	Glides
29" (28.94")	42" (42.68")	42" (41.68")	2	26 7/8"	33 1/2"	1 1/4"	Yes	Yes
	48" (47.68")	48" (47.68")	2	32 1/8"	36 1/2"	2 3/4"	Yes	Yes
42" (41.94")	42" (42.68")	42" (41.68")	2	26 7/8"	33 1/2"	1 1/4"	Yes	Yes
	48" (47.68")	48" (47.68")	2	32 1/8"	36 1/2"	2 3/4"	Yes	Yes

Product Details – Jive Tables

Bridge Base (4 Column) – Half Racetrack (Top)

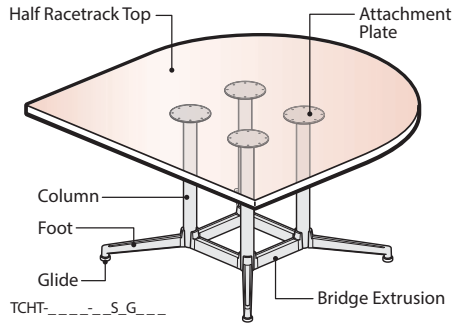

Wood Grain Direction

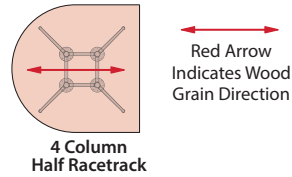

Top Cutout Options

- Power and Data access may be provided by specifying optional factory installed cutouts.
- Cutouts are designed to accommodate separately specified Flip Top Units

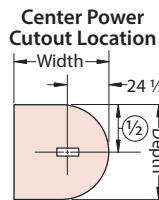

N No Cutout

F Center Power Cutout for 4 Port Single Sided Flip Top Unit

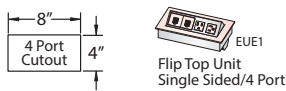

J Center Power Cutout for 6 Port Single Sided Flip Top Unit

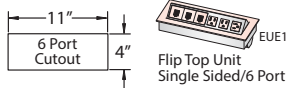

M Center Power Cutout for 8 Port Double Sided Flip Top Unit

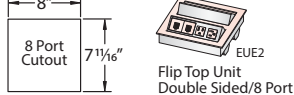

Base & Wire Management Options

- The 4 Column Bridge Base is standard with glides only, casters are not available.
- Casters and glides are not interchangeable.

Base - No Power

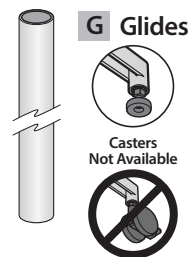

Does not provide access for cord management.

Base - Power Ready

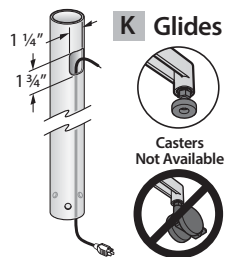

Provides access for cord management through (1) of the Round Column. Power ready leg location determined during installation.

Component Materials/Finishes

COMPONENT NAME		MATERIALS/ FINISHES
Half Racetrack Top	Edge Option is applied to all edges.	(L) Laminate – Specify separate top and edge finish colors. (W) Wood – Specify a single finish color for top and edge.
		(J) Edgeband (F) Knife (K) Edgeband (U) Knife
Bridge Base	Feet, Bridge Extrusion, Columns and Attachment Plates	(A) Painted – The Foot, Bridge Extrusion, Column and Attachment Plate are painted metal, specify base trim color. (B) Polished – The Foot and Bridge Extrusion is polished aluminum. Column and Attachment Plate are painted metal, specify base trim color.
	Glides	Standard In Black.

Sizes and Dimensions

Top View – 4 Column

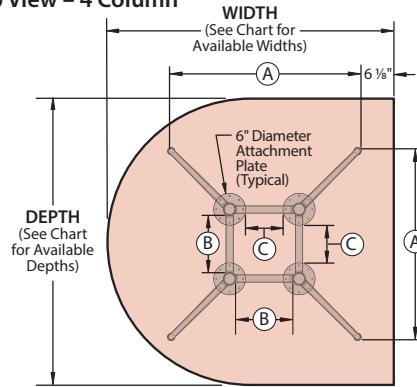

Front View – 4 Column with Glides

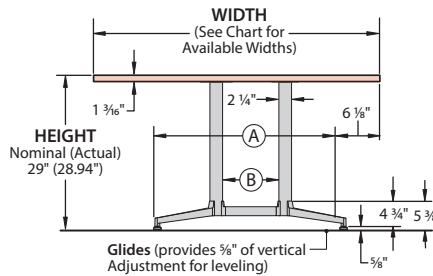

HEIGHT Nominal (Actual)	DEPTH Nominal (Actual)	WIDTH Nominal (Actual)	Number of Columns	Component Dimensions			Caster/Glide Availability	
				A	B	C	Casters	Glides
29" (28.94")	54" (53.68")	54" (53.68")	4	35 13/16"	10 3/4"	7"	No	Yes
	60" (59.68")	60" (59.68")	4	40 13/16"	15 3/4"	12"	No	Yes
42" (41.94")	54" (53.68")	54" (53.68")	4	35 13/16"	10 3/4"	7"	No	Yes
	60" (59.68")	60" (59.68")	4	40 13/16"	15 3/4"	12"	No	Yes

Table Heights

29" High Tables

- Seated applications.
- Specify with standard height seating (17"-18" seat heights).



42" High Tables

- Seated or standing applications.
- Specify with bar height stools (28"-30" seat heights).



Seating Capacity

- Recommended seating capacity based upon a width of 27" per chair.

WIDTH/DEPTH	
54" Wide / 54" Deep	60" Wide/ 60" Deep
 7 Chairs Maximum	 8 Chairs Maximum

Product Details – Jive Tables

Bridge Base (2 Column) – Half Pebble (Top)

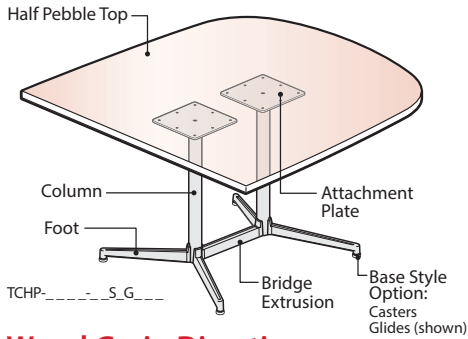

Wood Grain Direction

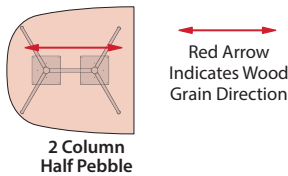

Base & Wire Management Options

Base – No Power

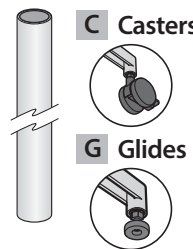

Does not provide access for cord management.

Base – Power Ready

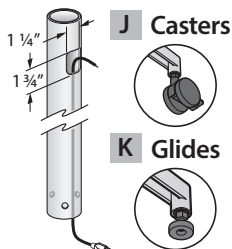

Provides access for cord management through (1) of the Round Column. Power ready leg location determined during installation.

Table Heights

42" High Tables

- Seated or standing applications.
- Specify with bar height stools (28"-30" seat heights).

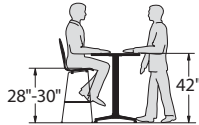

29" High Tables

- Seated applications.
- Specify with standard height seating (17"-18" seat heights).



Seating Capacity

- Recommended seating capacity based upon a width of 27" per chair.

WIDTH/DEPTH	
42" Wide/ 36" Deep	48" Wide/48" Deep
4 Chairs Maximum	5 Chairs Maximum

Component Materials/Finishes

COMPONENT NAME	MATERIALS/ FINISHES	
Half Pebble Top Edge Option is applied to all edges.	(L) Laminate – Specify separate top and edge finish colors.	(J) Edgeband
	(W) Wood – Specify a single finish color for top and edge.	(K) Edgeband (U) Knife
Bridge Base	(A) Painted – The Foot, Bridge Extrusion, Column and Attachment Plate are painted metal, specify base trim color.	
	(B) Polished – The Foot and Bridge Extrusion is polished aluminum. Column and Attachment Plate are painted metal, specify base trim color.	
Base Style	Casters – Standard in black.	
	Glides – Standard in black.	

Sizes and Dimensions

Top View – 2 Column

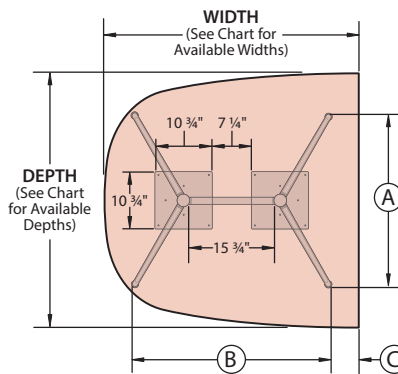

Front View – 2 Column with Glides

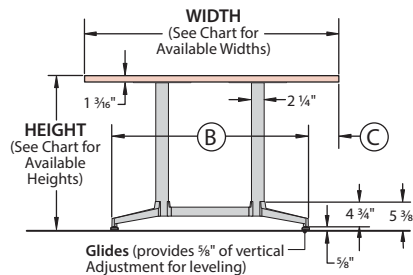

Front View – 2 Column with Casters

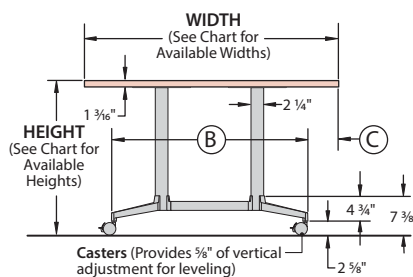

HEIGHT Nominal (Actual)	DEPTH Nominal (Actual)	WIDTH Nominal (Actual)	Number of Columns	Component Dimensions			Caster/Glide Availability	
				(A)	(B)	(C)	Casters	Glides
29" (28.94")	42" (41.68")	42" (41.68")	2	27 3/4"	34 3/8"	3 5/8"	Yes	Yes
	48" (47.68")	48" (47.68")	2	32 7/8"	37 3/8"	5 1/8"	Yes	Yes
42" (41.94")	42" (35.68")	42" (41.68")	2	27 3/4"	34 3/8"	3 5/8"	Yes	Yes
	48" (.68")	48" (47.68")	2	32 7/8"	37 3/8"	5 1/8"	Yes	Yes

Product Details – Jive Tables

Bridge Base (4 Column) – Half Pebble (Top)

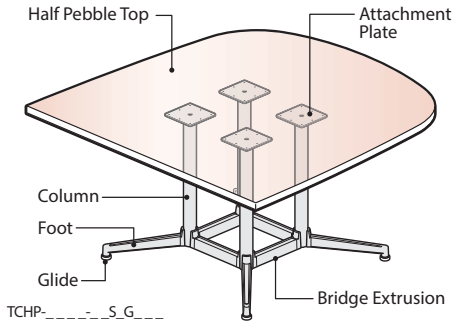

Wood Grain Direction

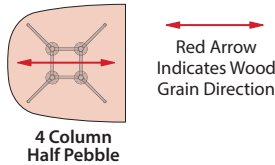

Top Cutout Options

- Power and Data access may be provided by specifying optional factory installed cutouts.
- Cutouts are designed to accommodate separately specified Flip Top Units

Cutout Location

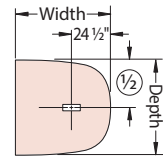

N No Cutout

F Center Power

Cutout for 4 Port Single Sided Flip Top Unit

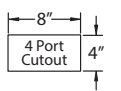

J Center Power

Cutout for 6 Port Single Sided Flip Top Unit

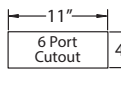

M Center Power

Cutout for 8 Port Double Sided Flip Top Unit

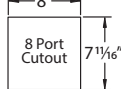

Base & Wire Management Options

- The 4 Column Bridge Base is standard with glides only, casters are not available.
- Casters and glides are not interchangeable.

Base - No Power

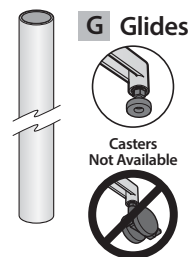

Does not provide access for cord management.

Base - Power Ready

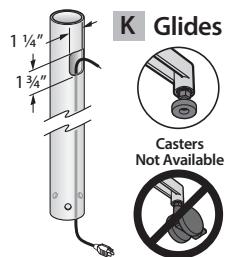

Provides access for cord management through (1) of the Round Column. Power ready leg location determined during installation.

Component Materials/Finishes

COMPONENT NAME		MATERIALS/ FINISHES	
Half Pebble Top	Edge Option is applied to all edges.	(L) Laminate – Specify separate top and edge finish colors.	(J) Edgeband
		(W) Wood – Specify a single finish color for top and edge.	(F) Knife (K) Edgeband (U) Knife
Bridge Base	Feet, Bridge Extrusion, Columns and Attachment Plates	(A) Painted – The Foot, Bridge Extrusion, Column and Attachment Plate are painted metal, specify base trim color.	
		(B) Polished – The Foot and Bridge Extrusion is polished aluminum. Column and Attachment Plate are painted metal, specify base trim color.	
	Glides	Standard In Black.	

Sizes and Dimensions

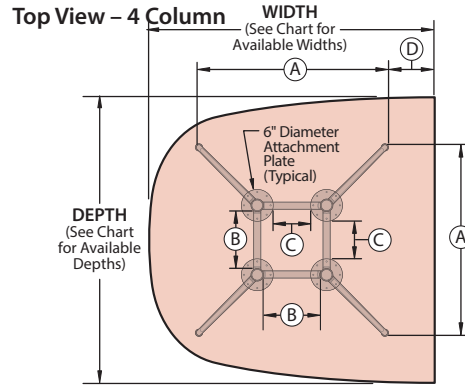

Front View – 4 Column with Glides

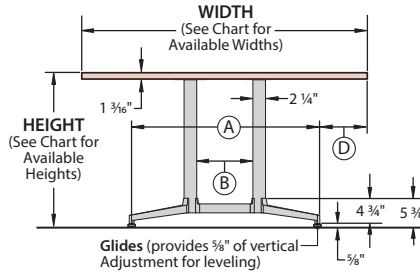

HEIGHT Nominal (Actual)	DEPTH Nominal (Actual)	WIDTH Nominal (Actual)	Number of Columns	Component Dimensions				Caster/Glide Availability	
				A	B	C	D	Casters	Glides
29" (28.94")	54" (53.68")	54" (53.68")	4	35 13/16"	10 3/4"	7"	8 15/16"	No	Yes
	60" (59.68")	60" (59.68")	4	40 13/16"	15 3/4"	12"	9 7/16"	No	Yes
42" (41.94")	54" (53.68")	54" (53.68")	4	35 13/16"	10 3/4"	7"	8 15/16"	No	Yes
	60" (59.68")	60" (59.68")	4	40 13/16"	15 3/4"	12"	9 7/16"	No	Yes

Table Heights

29" High Tables

- Seated applications.
- Specify with standard height seating (17"-18" seat heights).



42" High Tables

- Seated or standing applications.
- Specify with bar height stools (28"-30" seat heights).



Seating Capacity

- Recommended seating capacity based upon a width of 27" per chair.

WIDTH/DEPTH	
54" Wide / 54" Deep	60" Wide/ 60" Deep
7 Chairs Maximum	8 Chairs Maximum

Product Details – Jive Tables

Bridge Base (2 Column) – Half Hexagon (Top)

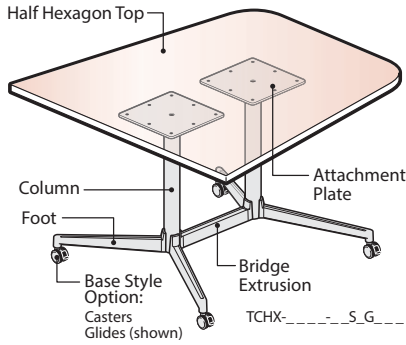

Component Materials/Finishes

COMPONENT NAME	MATERIALS/ FINISHES	
Half Hexagon Top Edge Option is applied to all edges.	(L) Laminate – Specify separate top and edge finish colors.	(J) Edgeband
	(W) Wood – Specify a single finish color for top and edge.	(F) Knife (K) Edgeband (U) Knife
Bridge Base	Feet, Bridge Extrusion Columns and Attachment Plates	(A) Painted – The Foot, Bridge Extrusion, Column and Attachment Plate are painted metal, specify base trim color.
		(B) Polished – The Foot and Bridge Extrusion is polished aluminum. Column and Attachment Plate are painted metal, specify base trim color.
Base Style	Casters – Standard in black.	
	Glides – Standard in black.	

Wood Grain Direction

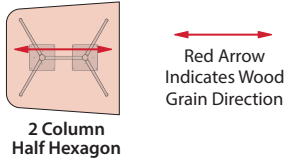

Sizes and Dimensions

Top View – 2 Column

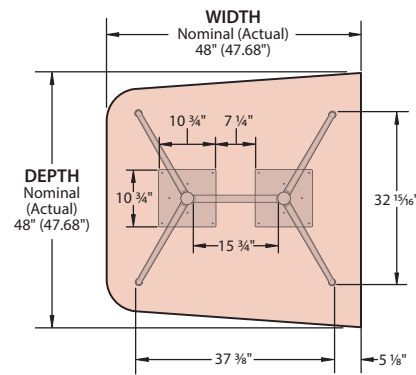

Base & Wire Management Options

Base - No Power

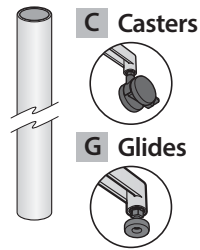

Does not provide access for cord management.

Base - Power Ready

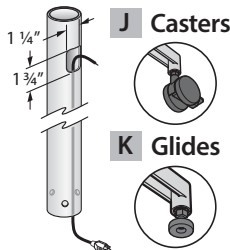

Provides access for cord management through (1) of the Round Column. Power ready leg location determined during installation.

Front View – 2 Column with Glides

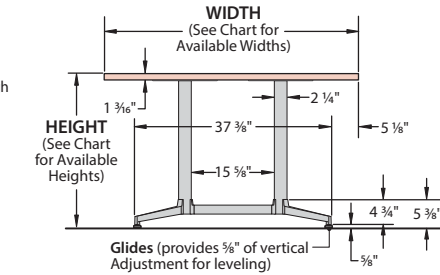
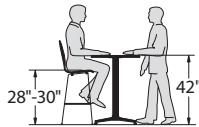

Table Heights

42" High Tables

- Seated or standing applications.
- Specify with bar height stools (28"-30" seat heights).



29" High Tables

- Seated applications.
- Specify with standard height seating (17"-18" seat heights).



Front View – 2 Column with Casters

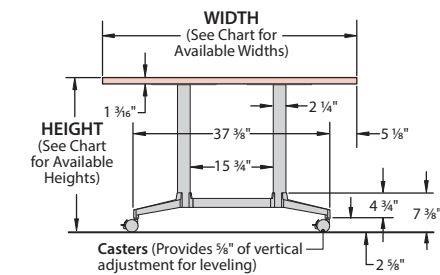

Seating Capacity

- Recommended seating capacity based upon a width of 27" per chair.

WIDTH/DEPTH
48" Wide / 48" Deep

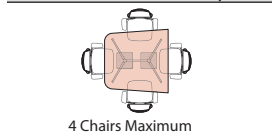

HEIGHT Nominal (Actual)	DEPTH Nominal (Actual)	WIDTH Nominal (Actual)	Number of Columns	Caster/Glide Availability	
				Casters	Glides
29" (28.94")	48" (47.68")	48" (47.68")	2	Yes	Yes
42" (41.94")	48" (47.68")	48" (47.68")	2	Yes	Yes

Product Details – Jive Tables

C-Leg – Extruded (Column) – Rectangle (Top)

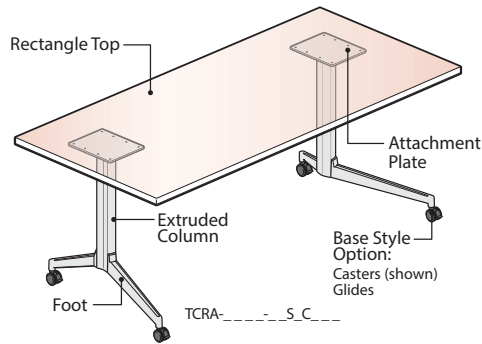

Component Materials/Finishes

COMPONENT NAME		MATERIALS/ FINISHES	
Rectangle Top	Edge option (Knife or Edgeband) is applied to user edge only, all other edges have 1mm edgeband.	(L) Laminate – Specify separate top and edge finish colors.	(J) Edgeband
		(W) Wood – Specify a single finish color for top and edge.	(F) Knife (K) Edgeband (U) Knife
C-Leg Extruded Base	Feet, Columns and Attachment Plates	(A) Painted – The Foot and Column are painted metal, specify base trim color. (B) Polished – The Foot is polished aluminum. The Column is painted metal with a specified base trim color.	
	Attachment Plates	Painted Metal – Standard in black.	
	Base Style	Casters – Standard in black. Glides – Standard in black.	

Wood Grain Direction

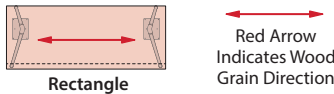

Base & Wire Management Options

Base - No Power

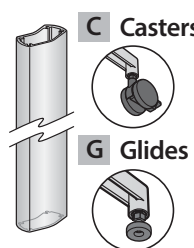

Does not provide access for cord management.

Base - Power Ready

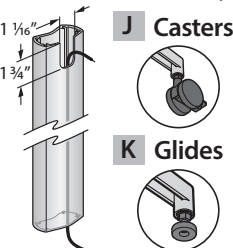

Provides access for cord management through (1) of the Post Extruded Legs. Power ready leg location determined during installation.

- Note**
- Only the 29" high Tables may be specified with the caster option. 42" high Tables are standard with Glides only.
 - Casters and glides are not interchangeable.

Top Cutout Options

- Power and Data access may be provided by specifying optional factory installed cutouts.
- Cutouts are designed to accommodate separately specified Flip Top Units.

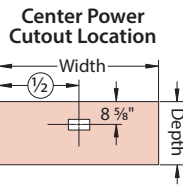

N No Cutout

A Center Power
Cutout for 4-Port Single Sided Flip Top Unit



F Center Power
Cutout for 4-Port Single Sided Flip Top Unit

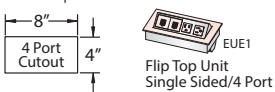

J Center Power
Cutout for 6-Port Single Sided Flip Top Unit

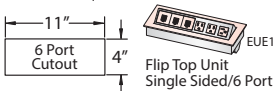
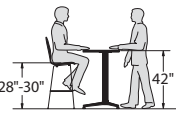

Table Heights

42" High Tables

- Seated or standing applications.
- Specify with bar height stools (28"-30" seat heights).



29" High Tables

- Seated applications.
- Specify with standard height seating (17"-18" seat heights).



Sizes and Dimensions

Top View

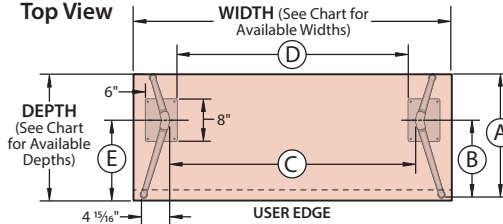

Front View with Glides

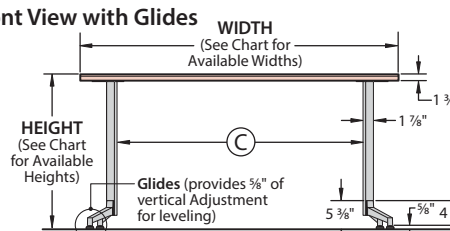

Side View with Glides

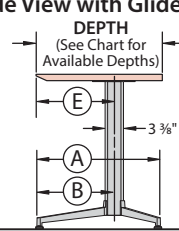

Front View with Casters

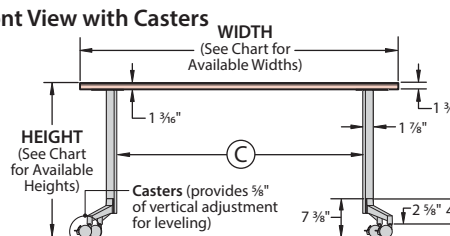

Side View with Casters

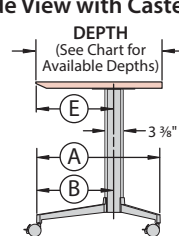

HEIGHT Nominal (Actual)	DEPTH Nominal (Actual)	WIDTH Nominal (Actual)	Number of Columns	Component Dimensions					Caster/Glide Availability	
				(A)	(B)	(C)	(D)	(E)	Casters	Glides
24" (23.68")	24" (23.68")	36" (35.68")	2	23 3/8"	14 1/2"	19 7/8"	16 1/8"	14 7/8"	Yes	Yes
		42" (41.68")	2	23 3/8"	14 1/2"	25 7/8"	22 1/8"	14 7/8"	Yes	Yes
		48" (47.68")	2	23 3/8"	14 1/2"	31 7/8"	28 1/8"	14 7/8"	Yes	Yes
		54" (53.68")	2	23 3/8"	14 1/2"	37 7/8"	34 1/8"	14 7/8"	Yes	Yes
		60" (59.68")	2	23 3/8"	14 1/2"	43 7/8"	40 1/8"	14 7/8"	Yes	Yes
		66" (65.68")	2	23 3/8"	14 1/2"	49 7/8"	46 1/8"	14 7/8"	Yes	Yes
29" (28.94")	29" (28.94")	36" (35.68")	2	23 3/8"	14 1/2"	19 7/8"	16 1/8"	14 7/8"	Yes	Yes
		42" (41.68")	2	27 1/2"	15 1/8"	25 7/8"	25.2"	17 7/8"	Yes	Yes
		48" (47.68")	2	27 1/2"	15 1/8"	31 7/8"	31.2"	17 7/8"	Yes	Yes
		54" (53.68")	2	27 1/2"	15 1/8"	37 7/8"	37.2"	17 7/8"	Yes	Yes
		60" (59.68")	2	27 1/2"	15 1/8"	43 7/8"	43.2"	17 7/8"	Yes	Yes
		66" (65.68")	2	27 1/2"	15 1/8"	49 7/8"	49.2"	17 7/8"	Yes	Yes
42" (41.94")	24" (23.68")	36" (35.68")	2	23 3/8"	14 1/2"	19 7/8"	16 1/8"	14 7/8"	No	Yes
		42" (41.68")	2	23 3/8"	14 1/2"	25 7/8"	22 1/8"	14 7/8"	No	Yes
		48" (47.68")	2	23 3/8"	14 1/2"	31 7/8"	28 1/8"	14 7/8"	No	Yes
		54" (53.68")	2	23 3/8"	14 1/2"	37 7/8"	34 1/8"	14 7/8"	No	Yes
		60" (59.68")	2	23 3/8"	14 1/2"	43 7/8"	40 1/8"	14 7/8"	No	Yes
		66" (65.68")	2	23 3/8"	14 1/2"	49 7/8"	46 1/8"	14 7/8"	No	Yes
	30" (29.68")	36" (35.68")	2	27 1/2"	15 1/8"	19 7/8"	19.2"	17 7/8"	No	Yes
		42" (41.68")	2	27 1/2"	15 1/8"	25 7/8"	25.2"	17 7/8"	No	Yes
		48" (47.68")	2	27 1/2"	15 1/8"	31 7/8"	31.2"	17 7/8"	No	Yes
		54" (53.68")	2	27 1/2"	15 1/8"	37 7/8"	37.2"	17 7/8"	No	Yes
		60" (59.68")	2	27 1/2"	15 1/8"	43 7/8"	43.2"	17 7/8"	No	Yes
		66" (65.68")	2	27 1/2"	15 1/8"	49 7/8"	49.2"	17 7/8"	No	Yes

Product Details – Jive Tables

C-Leg – Round (Column) – Rectangle (Top)

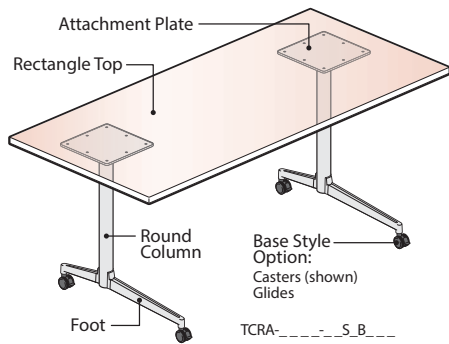

Component Materials/Finishes

COMPONENT NAME		MATERIALS/ FINISHES	
C-Leg Round Base	Rectangle Top	(L) Laminate – Specify separate top and edge finish colors. Edge option (Knife or Edgeband) is applied to user edge only, all other edges have 1mm edgeband.	(J) Edgeband (F) Knife (K) Edgeband (U) Knife
	Feet, Columns and Attachment Plates	(W) Wood – Specify a single finish color for top and edge. (A) Painted – The Foot, Column and Attachment Plate are painted metal, specify base trim color. (B) Polished – The Foot is polished aluminum. Column and Attachment Plate are painted metal, specify base trim color.	
	Base Style	Casters – Standard in black. Glides – Standard in black.	

Wood Grain Direction

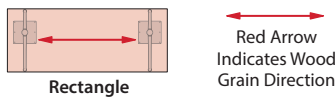

Top Cutout Options

- Power and Data access may be provided by specifying optional factory installed cutouts.
- Cutouts are designed to accommodate separately specified Flip Top Units.

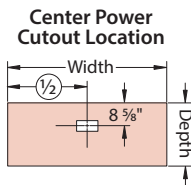

N No Cutout

A Center Power
Cutout for 4-Port Single Sided Flip Top Unit



F Center Power
Cutout for 4-Port Single Sided Flip Top Unit



J Center Power
Cutout for 6-Port Single Sided Flip Top Unit

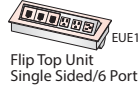

Base & Wire Management Options

Base - No Power

Base - Power Ready

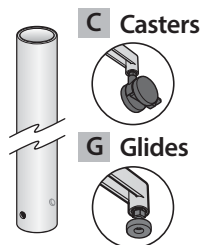

Does not provide access for cord management.

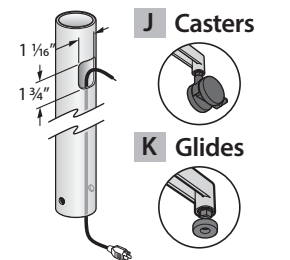

Provides access for cord management through (1) of the Round Column. Power ready leg location determined during installation.

- Note**
- Only the 29" high Tables may be specified with the caster option. 42" high Tables are standard with Glides only.
 - Casters and glides are not interchangeable.

Table Heights

42" High Tables

- Seated or standing applications.
- Specify with bar height stools (28"-30" seat heights).

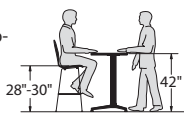

29" High Tables

- Seated applications.
- Specify with standard height seating (17"-18" seat heights).

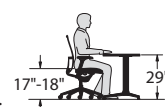

Sizes and Dimensions

Top View

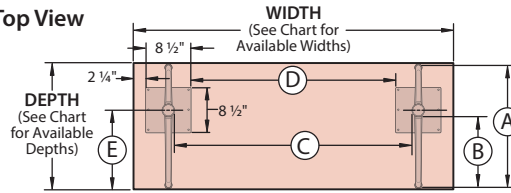

Front View with Glides

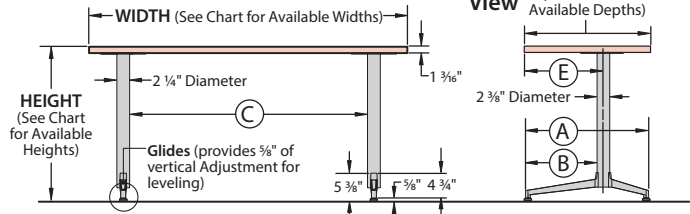

Front View with Casters

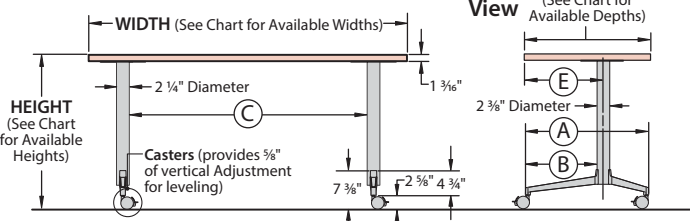

HEIGHT Nominal (Actual)	DEPTH Nominal (Actual)	WIDTH Nominal (Actual)	Number of Columns	Component Dimensions					Caster/Glide Availability		
				(A)	(B)	(C)	(D)	(E)	Casters	Glides	
24" (23.68")	24" (23.68")	36" (35.68")	2	22 7/8"	13 1/4"	20 7/8"	14 3/16"	14 7/8"	Yes	Yes	
		42" (41.68")	2	22 7/8"	13 1/4"	26 7/8"	20 3/16"	14 7/8"	Yes	Yes	
		48" (47.68")	2	22 7/8"	13 1/4"	32 7/8"	26 3/16"	14 7/8"	Yes	Yes	
		54" (53.68")	2	22 7/8"	13 1/4"	38 7/8"	32 3/16"	14 7/8"	Yes	Yes	
		60" (59.68")	2	22 7/8"	13 1/4"	44 7/8"	38 3/16"	14 7/8"	Yes	Yes	
		66" (65.68")	2	22 7/8"	13 1/4"	50 7/8"	44 3/16"	14 7/8"	Yes	Yes	
29" (28.94")	29" (28.94")	72" (71.68")	2	22 7/8"	13 1/4"	56 7/8"	50 3/16"	14 7/8"	Yes	Yes	
		36" (35.68")	2	27 3/8"	14 3/4"	20 7/8"	14 3/16"	17 7/8"	Yes	Yes	
		42" (41.68")	2	27 3/8"	14 3/4"	26 7/8"	20 3/16"	17 7/8"	Yes	Yes	
		48" (47.68")	2	27 3/8"	14 3/4"	32 7/8"	26 3/16"	17 7/8"	Yes	Yes	
		54" (53.68")	2	27 3/8"	14 3/4"	38 7/8"	32 3/16"	17 7/8"	Yes	Yes	
		60" (59.68")	2	27 3/8"	14 3/4"	44 7/8"	38 3/16"	17 7/8"	Yes	Yes	
42" (41.94")	24" (23.68")	66" (65.68")	2	27 3/8"	14 3/4"	50 7/8"	44 3/16"	17 7/8"	Yes	Yes	
		72" (71.68")	2	27 3/8"	14 3/4"	56 7/8"	50 3/16"	17 7/8"	Yes	Yes	
		36" (35.68")	2	22 7/8"	13 1/4"	20 7/8"	14 3/16"	14 7/8"	No	Yes	
		42" (41.68")	2	22 7/8"	13 1/4"	26 7/8"	20 3/16"	14 7/8"	No	Yes	
		48" (47.68")	2	22 7/8"	13 1/4"	32 7/8"	26 3/16"	14 7/8"	No	Yes	
		54" (53.68")	2	22 7/8"	13 1/4"	38 7/8"	32 3/16"	14 7/8"	No	Yes	
	30" (29.68")	30" (29.68")	60" (59.68")	2	22 7/8"	13 1/4"	44 7/8"	38 3/16"	14 7/8"	No	Yes
			66" (65.68")	2	22 7/8"	13 1/4"	50 7/8"	44 3/16"	14 7/8"	No	Yes
			72" (71.68")	2	22 7/8"	13 1/4"	56 7/8"	50 3/16"	14 7/8"	No	Yes
			36" (35.68")	2	27 3/8"	14 3/4"	20 7/8"	14 3/16"	17 7/8"	No	Yes
			42" (41.68")	2	27 3/8"	14 3/4"	26 7/8"	20 3/16"	17 7/8"	No	Yes
			48" (47.68")	2	27 3/8"	14 3/4"	32 7/8"	26 3/16"	17 7/8"	No	Yes

Product Details – Jive Tables

C-Leg Extruded (Column) – Flip Base (Rectangle Top)

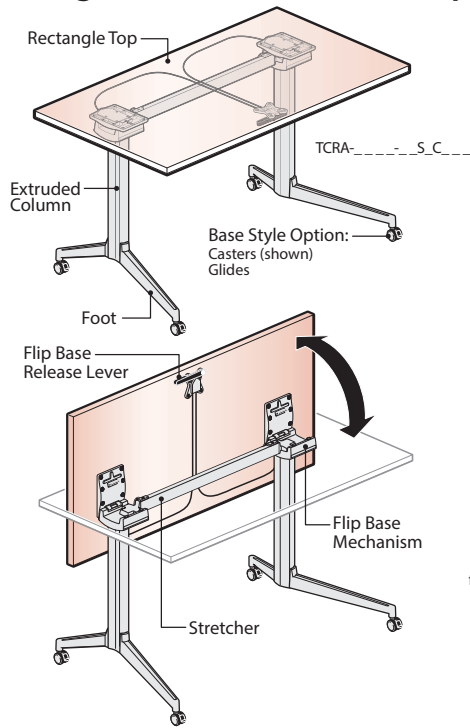

Component Materials/Finishes

COMPONENT NAME		MATERIALS/ FINISHES	
C-Leg Extruded Base	Rectangle Top Edge option (Knife or Edgeband) is applied to user edge only, all other edges have 1mm edgeband.	(L) Laminate – Specify separate top and edge finish colors.	(J) Edgeband
		(W) Wood – Specify a single finish color for top and edge.	(F) Knife (K) Edgeband (U) Knife
		(A) Painted – The Foot, Column and stretcher are painted metal, specify base trim color. (B) Polished – The Foot is polished aluminum. The Column and Stretcher are painted metal, specify base trim color.	
	Flip Base Mechanism	Painted Metal – Standard in black.	
	Release Lever	Plastic lever standard in black.	
	Base Style	Casters – Standard in black. Glides – Standard in black.	

Sizes and Dimensions

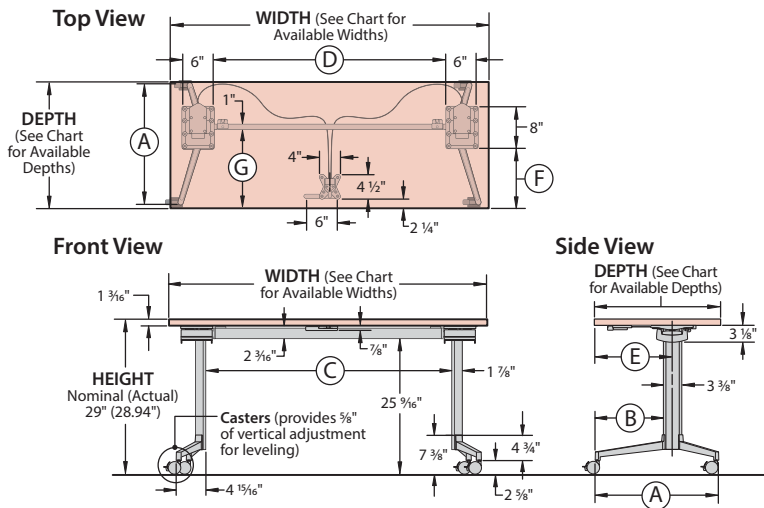

Wood Grain Direction

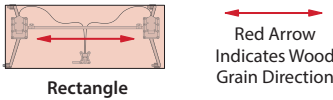

Top Cutout Options

- Power and Data access may be provided by specifying optional factory installed cutouts.
- Cutouts are designed to accommodate separately specified Flip Top Units.

N No Cutout

- A Center Power**
Cutout for 2-Port Single Sided Flip Top Unit

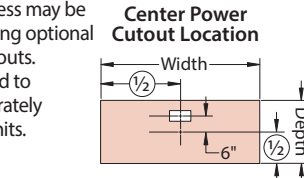

- F Center Power**
Cutout for 4-Port Single Sided Flip Top Unit



- J Center Power**
Cutout for 6-Port Single Sided Flip Top Unit

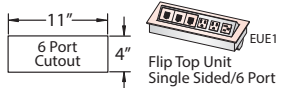

Nesting Flip Tables

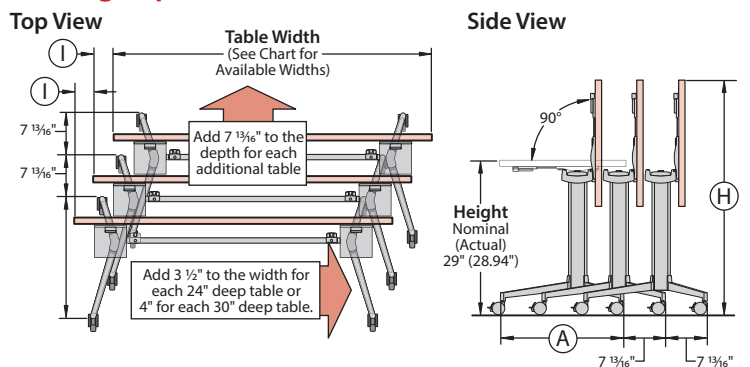

Base & Wire Management Options

Base - No Power Base - Power Ready

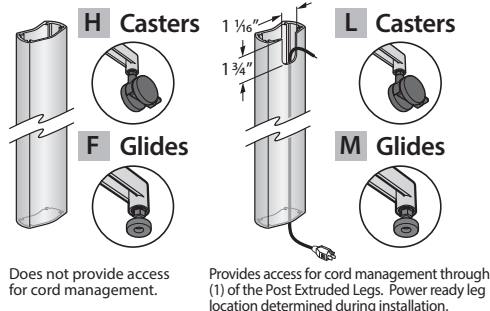

HEIGHT Nominal (Actual)	DEPTH Nominal (Actual)	WIDTH Nominal (Actual)	Component Dimensions									Caster/Glide Availability	
			A	B	C	D	E	F	G	H	I	Casters	Glides
29" (28.94")	24" (23.68")	48" (47.68")	23 3/8"	12 3/4"	32 1/4"	28"	14 13/16"	10 13/16"	14 3/8"	44 1/2"	3 1/2"	Yes	Yes
		60" (59.68")	23 3/8"	12 3/4"	44 1/4"	40"	14 13/16"	10 13/16"	14 3/8"	44 1/2"	3 1/2"	Yes	Yes
		72" (71.68")	23 3/8"	12 3/4"	56 1/4"	52"	14 13/16"	10 13/16"	14 3/8"	44 1/2"	3 1/2"	Yes	Yes
	30" (29.68")	48" (47.68")	27 1/2"	14 1/4"	32 1/4"	28"	17 13/16"	13 13/16"	17 5/8"	47 1/2"	4"	Yes	Yes
		60" (59.68")	27 1/2"	14 1/4"	44 1/4"	40"	17 13/16"	13 13/16"	17 5/8"	47 1/2"	4"	Yes	Yes
		72" (71.68")	27 1/2"	14 1/4"	56 1/4"	52"	17 13/16"	13 13/16"	17 5/8"	47 1/2"	4"	Yes	Yes

Table Heights

29" High Tables

- Seated applications.
- Specify with standard height seating (17"-18" seat heights).



Product Details – Jive Tables

C-Leg Round (Column) – Flip Base (Rectangle Top)

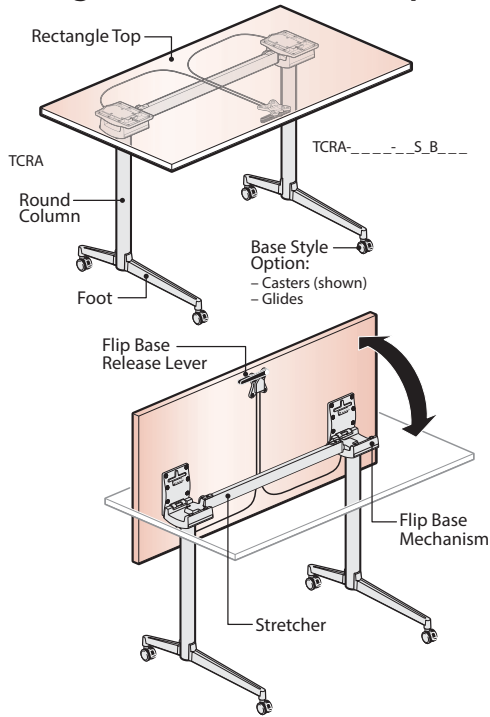

Wood Grain Direction

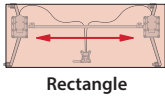

Red Arrow Indicates Wood Grain Direction

Top Cutout Options

- Power and Data access may be provided by specifying optional factory installed cutouts.
- Cutouts are designed to accommodate separately specified Flip Top Units.

N No Cutout

A Center Power
Cutout for 2-Port Single Sided Flip Top Unit



EUE1
Flip Top Unit Single Sided/4 Port

F Center Power
Cutout for 4-Port Single Sided Flip Top Unit



EUE1
Flip Top Unit Single Sided/4 Port

J Center Power
Cutout for 6-Port Single Sided Flip Top Unit



EUE1
Flip Top Unit Single Sided/6 Port

Base & Wire Management Options

Base - No Power

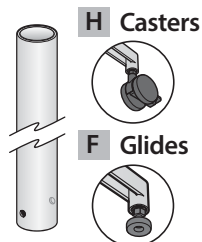

Does not provide access for cord management.

Base - Power Ready

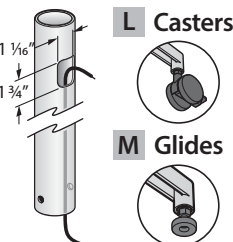

Provides access for cord management through (1) of the Round Column. Power ready leg location determined during installation.

Component Materials/Finishes

COMPONENT NAME	MATERIALS/ FINISHES	
Rectangle Top Edge option (Knife or Edgeband) is applied to user edge only, all other edges have 1mm edgeband.	(L) Laminate – Specify separate top and edge finish colors.	(J) Edgeband
	(W) Wood – Specify a single finish color for top and edge.	(F) Knife (K) Edgeband (U) Knife
C-Leg Round Base	Feet, Round Columns, and Stretcher	(A) Painted – The Foot, Column and stretcher are painted metal, specify base trim color. (B) Polished – The Foot is polished aluminum. The Column and Stretcher are painted metal, specify base trim color.
	Flip Base Mechanism	Painted Metal – Standard in black.
	Release Lever	Plastic lever standard in black.
	Casters	Standard In Black.

Sizes and Dimensions

Top View

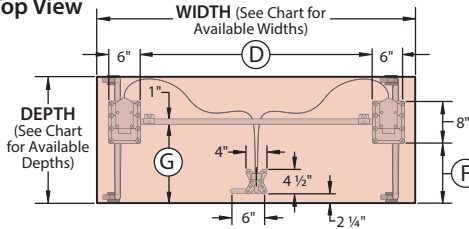

Front View

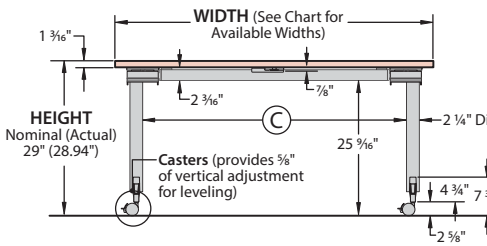

Side View

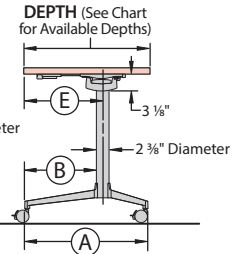

Nesting Flip Tables

Top View

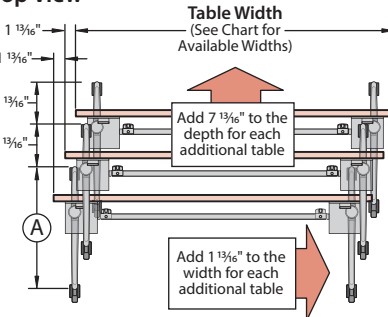

Side View

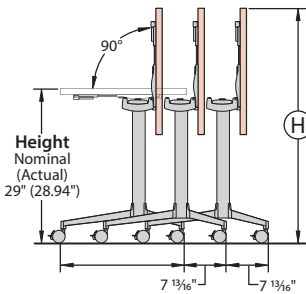

HEIGHT Nominal (Actual)	DEPTH Nominal (Actual)	WIDTH Nominal (Actual)	Component Dimensions								Caster/Glide Availability	
			A	B	C	D	E	F	G	H	Casters	Glides
29" (28.94")	24" (23.68")	48" (47.68")	22 7/8"	13 1/4"	31 3/4"	28"	14 13/16"	10 13/16"	14 3/16"	44 1/2"	Yes	Yes
	60" (59.68")	22 7/8"	13 1/4"	43 3/4"	40"	14 13/16"	10 13/16"	14 3/16"	44 1/2"	Yes	Yes	
	72" (71.68")	22 7/8"	13 1/4"	55 3/4"	52"	14 13/16"	10 13/16"	14 3/16"	44 1/2"	Yes	Yes	
30 (29.68")	48" (47.68")	27 3/8"	14 3/4"	31 3/4"	28"	17 13/16"	13 13/16"	17 3/16"	47 1/2"	Yes	Yes	
	60" (59.68")	27 3/8"	14 3/4"	43 3/4"	40"	17 13/16"	13 13/16"	17 3/16"	47 1/2"	Yes	Yes	
	72" (71.68")	27 3/8"	14 3/4"	55 3/4"	52"	17 13/16"	13 13/16"	17 3/16"	47 1/2"	Yes	Yes	

Table Heights

29" High Tables

- Seated applications.
- Specify with standard height seating (17"-18" seat heights).



Product Details – Jive Tables

Disc Base – Round (Top)

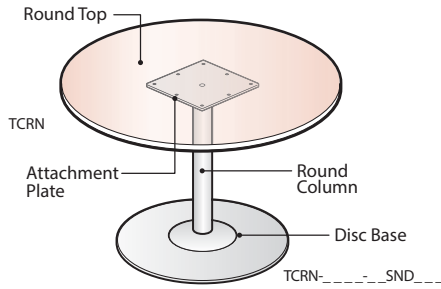

Component Materials/Finishes

COMPONENT NAME		MATERIALS/ FINISHES	
Round Top	Edge option (Knife or Edgeband) is applied to all edges.	(L) Laminate Specify separate top and edge finish colors.	(J) Edgeband (F) Knife
		(W) Wood Specify a single finish color for top and edge.	(K) Edgeband (U) Knife
Disc Base	Disc Base, Round Column and Attachment Plates	Painted – Specify Base Trim Color	
	Glides (Non-Adjustable)	Plastic	

Wood Grain Direction

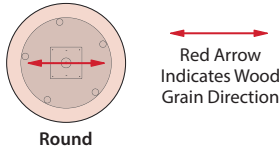

Base & Wire Management Options

Base - No Power

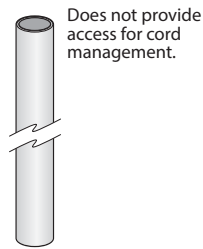

Does not provide access for cord management.

Base - Power Ready

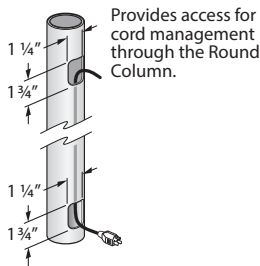

Provides access for cord management through the Round Column.

Table Heights

36" High Tables

- Seated or standing applications.
- Specify with counter height stools (24"-26" seat heights).

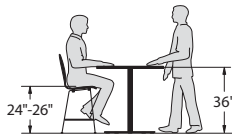

29" High Tables

- Seated applications.
- Specify with standard height seating (17"-18" seat heights).



20" High Tables

- Seated or lounge applications.
- Specify with standard or lounge height seating (14"-18" seat heights).

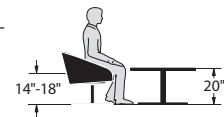

16" High Tables

- Seated or lounge applications.
- Specify with standard or lounge height seating (14"-18" seat heights).



Sizes and Dimensions

Top View

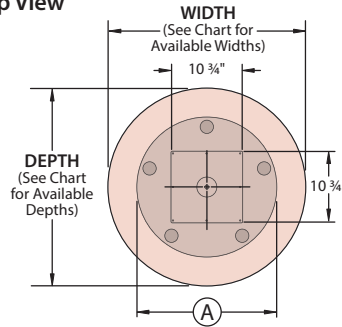

Front View – 29" High

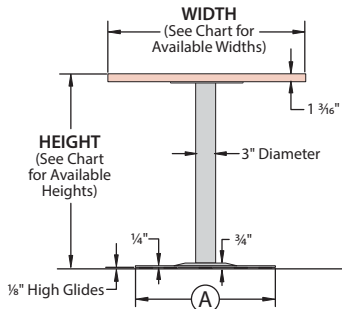

HEIGHT Nominal (Actual)	WIDTH/DEPTH Nominal (Actual)	Component Dimensions
		(A)
16" (15.94")	24" (23.68")	21"
	30" (29.68")	21"
	36" (35.68")	27 3/16"
	42" (41.68")	27 3/16"
20" (19.94")	24" (23.68")	21"
	30" (29.68")	21"
	36" (35.68")	27 3/16"
	42" (41.68")	27 3/16"
29" (28.94")	24" (23.68")	21"
	30" (29.68")	21"
	36" (35.68")	27 3/16"
	42" (41.68")	27 3/16"
36" (35.94")	24" (23.68")	21"
	30" (29.68")	21"
	36" (35.68")	27 3/16"
	42" (41.68")	27 3/16"

Product Details – Jive Tables

Disc Base – Square (Top)

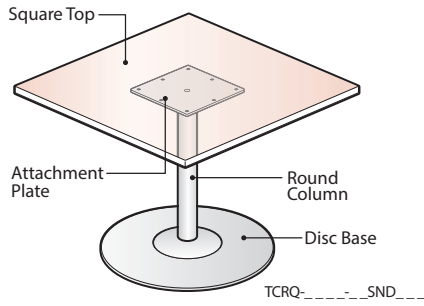

Wood Grain Direction

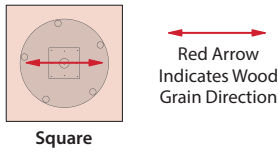

Base & Wire Management Options

Base - No Power

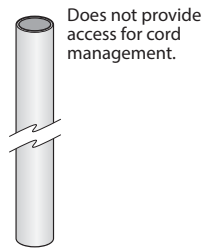

Does not provide access for cord management.

Base - Power Ready

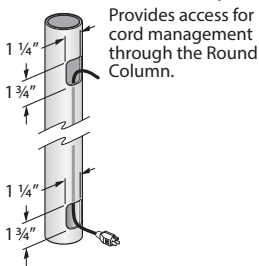

Provides access for cord management through the Round Column.

Table Heights

36" High Tables

- Seated or standing applications.
- Specify with counter height stools (24"-26" seat heights).

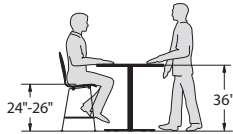

29" High Tables

- Seated applications.
- Specify with standard height seating (17"-18" seat heights).



20" High Tables

- Seated or lounge applications.
- Specify with standard or lounge height seating (14"-18" seat heights).



16" High Tables

- Seated or lounge applications.
- Specify with standard or lounge height seating (14"-18" seat heights).



Component Materials/Finishes

COMPONENT NAME		MATERIALS/ FINISHES	
Square Top Edge option (Knife or Edgeband) is applied to all edges.		(L) Laminate Specify separate top and edge finish colors.	(J) Edgeband
		(W) Wood Specify a single finish color for top and edge.	(F) Knife (K) Edgeband (U) Knife
Disc Base	Disc Base, Round Column and Attachment Plates	Painted – Specify Base Trim Color	
	Glides (Non-Adjustable)	Standard In Black.	

Sizes and Dimensions

Top View

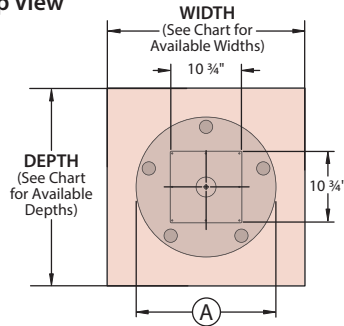

Front View – 29" High

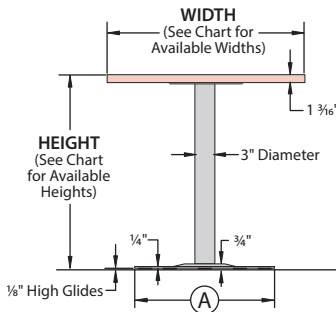

HEIGHT Nominal (Actual)	WIDTH/DEPTH Nominal (Actual)	Component Dimensions
		(A)
16" (15.94")	24" (23.68")	21"
	30" (29.68")	21"
	36" (35.68")	27 3/16"
	42" (41.68")	27 3/16"
20" (19.94")	24" (23.68")	21"
	30" (29.68")	21"
	36" (35.68")	27 3/16"
	42" (41.68")	27 3/16"
29" (28.94")	24" (23.68")	21"
	30" (29.68")	21"
	36" (35.68")	27 3/16"
	42" (41.68")	27 3/16"
36" (35.94")	24" (23.68")	21"
	30" (29.68")	21"
	36" (35.68")	27 3/16"

Product Details – Jive Tables

Disc Base – Pebble (Top)

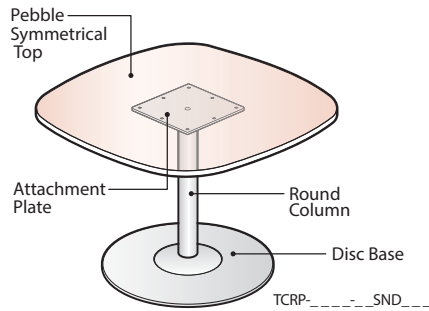

Wood Grain Direction

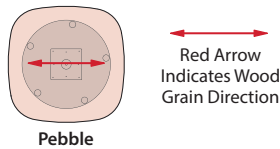

Base & Wire Management Options

Base - No Power

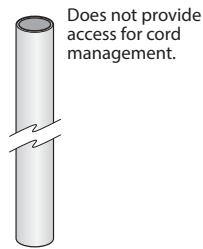

Does not provide access for cord management.

Base - Power Ready

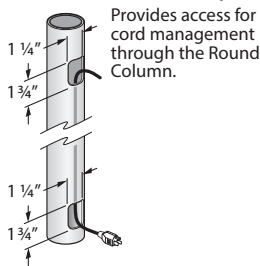

Provides access for cord management through the Round Column.

Table Heights

36" High Tables

- Seated or standing applications.
- Specify with counter height stools (24"-26" seat heights).

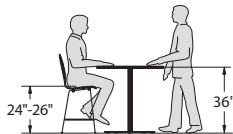

29" High Tables

- Seated applications.
- Specify with standard height seating (17"-18" seat heights).



20" High Tables

- Seated or lounge applications.
- Specify with standard or lounge height seating (14"-18" seat heights).



16" High Tables

- Seated or lounge applications.
- Specify with standard or lounge height seating (14"-18" seat heights).



Component Materials/Finishes

COMPONENT NAME		MATERIALS/ FINISHES	
Pebble Symmetrical Top	Edge option (Knife or Edgeband) is applied to all edges.	(L) Laminate Specify separate top and edge finish colors.	(J) Edgeband (F) Knife
		(W) Wood Specify a single finish color for top and edge.	(K) Edgeband (U) Knife
Disc Base	Disc Base, Round Column and Attachment Plates	Painted – Specify Base Trim Color	
	Glides (Non-Adjustable)	Standard In Black.	

Sizes and Dimensions

Top View

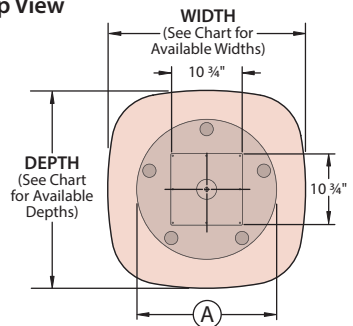

Front View – 29" High

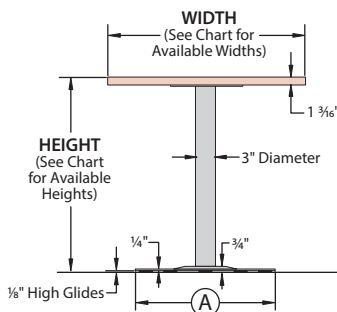

HEIGHT Nominal (Actual)	WIDTH/DEPTH Nominal (Actual)	Component Dimensions
		(A)
16" (15.94")	24" (23.68")	21"
	30" (29.68")	21"
	36" (35.68")	27 3/16"
	42" (41.68")	27 3/16"
20" (19.94")	24" (23.68")	21"
	30" (29.68")	21"
	36" (35.68")	27 3/16"
	42" (41.68")	27 3/16"
29" (28.94")	24" (23.68")	21"
	30" (29.68")	21"
	36" (35.68")	27 3/16"
	42" (41.68")	27 3/16"
36" (35.94")	24" (23.68")	21"
	30" (29.68")	21"
	36" (35.68")	27 3/16"
	42" (41.68")	27 3/16"

Product Details – Jive Tables

Disc Base – Rectangle (Top)

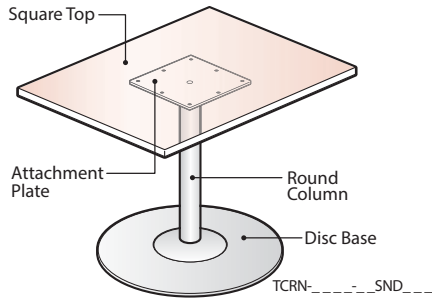

Wood Grain Direction

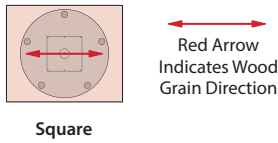

Base & Wire Management Options

Base - No Power

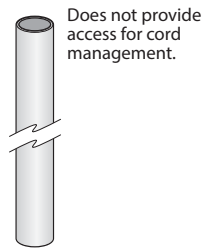

Base - Power Ready

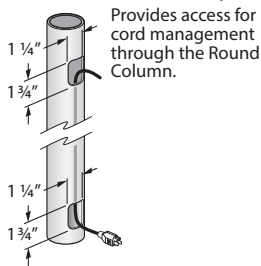
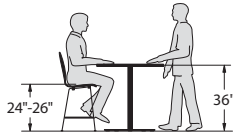

Table Heights

36" High Tables

- Seated or standing applications.
- Specify with counter height stools (24"-26" seat heights).



29" High Tables

- Seated applications.
- Specify with standard height seating (17"-18" seat heights).



20" High Tables

- Seated or lounge applications.
- Specify with standard or lounge height seating (14"-18" seat heights).

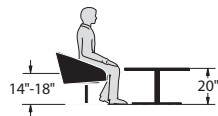

16" High Tables

- Seated or lounge applications.
- Specify with standard or lounge height seating (14"-18" seat heights).

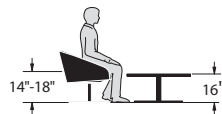

Component Materials/Finishes

COMPONENT NAME		MATERIALS/ FINISHES	
Rectangle Top Edge option (Knife or Edgeband) is applied to all edges.		(L) Laminate Specify separate top and edge finish colors.	(J) Edgeband
		(W) Wood Specify a single finish color for top and edge.	(F) Knife (K) Edgeband (U) Knife
Disc Base	Disc Base, Round Column and Attachment Plates	Painted – Specify Base Trim Color	
	Glides (Non-Adjustable)	Standard In Black.	

Sizes and Dimensions

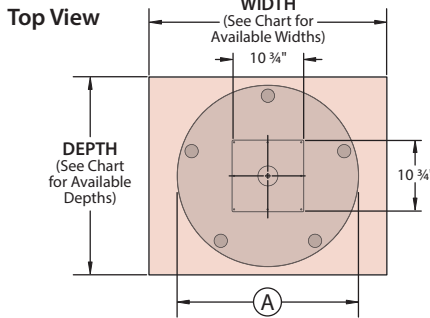

Front View – 29" High

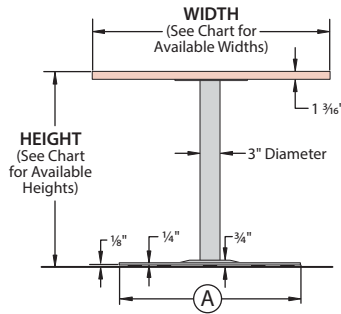

HEIGHT Nominal (Actual)	DEPTH Nominal (Actual)	WIDTH Nominal (Actual)	Component Dimensions
			(A)
16" (15.94")	30" (29.68")	36" (35.68")	27 3/16"
20" (19.94")	30" (29.68")	36" (35.68")	27 3/16"
29" (28.94")	30" (29.68")	36" (35.68")	27 3/16"
36" (35.94")	30" (29.68")	36" (35.68")	27 3/16"

Product Details – Jive Tables

Dual Disc Base – Pebble Asymmetrical (Top)

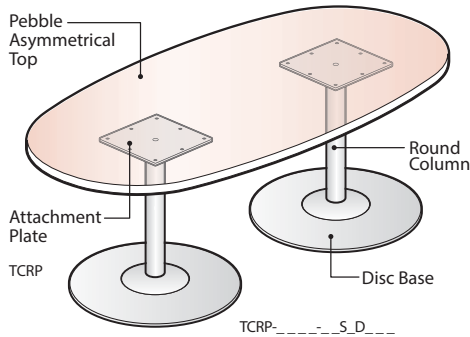

Component Materials/Finishes

COMPONENT NAME		MATERIALS/ FINISHES	
Pebble Asymmetrical Top	Edge option (Knife or Edgeband) is applied to all edges.	(L) Laminate Specify separate top and edge finish colors.	(J) Edgeband (F) Knife
		(W) Wood Specify a single finish color for top and edge.	(K) Edgeband (U) Knife
Disc Base	Disc Base, Round Column and Attachment Plates	Painted – Specify Base Trim Color	
	Glides (Non-Adjustable)	Standard In Black.	

Wood Grain Direction

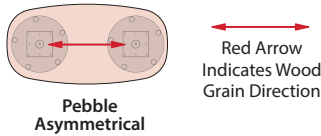

Top Cutout Options

- Power and Data access may be provided by specifying optional factory installed cutouts.
- Cutouts are designed to accommodate separately specified Flip Top Units.

Center Power Cutout Location

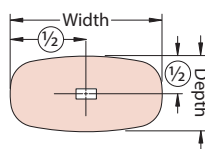

N No Cutout

F Center Power Cutout for 4-Port Single Sided Flip Top Unit

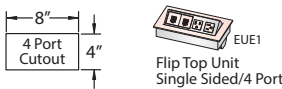

J Center Power Cutout for 6-Port Single Sided Flip Top Unit

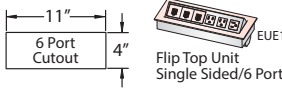

M Center Power Cutout for 8-Port Double Sided Flip Top Unit

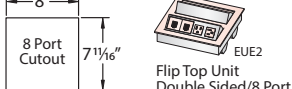

Q Center Power Cutout for 12-Port Double Sided Flip Top Unit

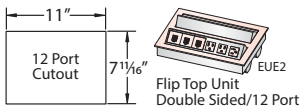

Base & Wire Management Options

Base - No Power

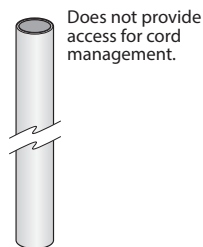

Base - Power Ready

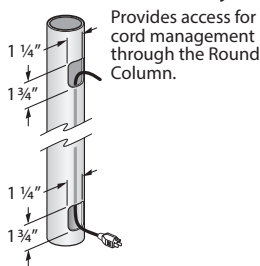

Sizes and Dimensions

Top View

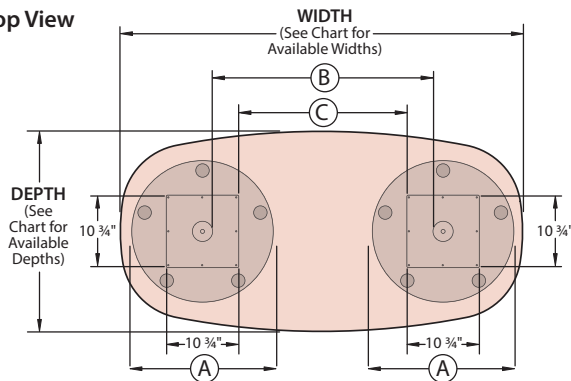

Front View

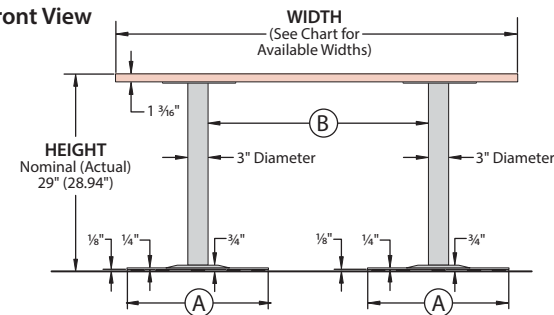

HEIGHT Nominal (Actual)	DEPTH Nominal (Actual)	WIDTH Nominal (Actual)	Component Dimensions		
			A	B	C
29" (28.94")	30" (29.68")	60" (59.68")	21"	21"	20 1/2"
		72" (71.68")	21"	39"	32 1/2"
	36" (35.68")	72" (71.68")	27 3/16"	33"	26 1/2"
		84" (83.68")	27 3/16"	45"	38 1/2"
		96" (95.68")	27 3/16"	51"	44 1/2"
36" (35.94")	30" (29.68")	60" (59.68")	21"	21"	20 1/2"
		72" (71.68")	21"	39"	32 1/2"
	36" (35.68")	72" (71.68")	27 3/16"	33"	26 1/2"
		84" (83.68")	27 3/16"	45"	38 1/2"
		96" (95.68")	27 3/16"	51"	44 1/2"

Table Heights

36" High Tables

- Seated or standing applications.
- Specify with counter height stools (24"-26" seat heights).

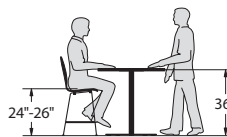

29" High Tables

- Seated applications.
- Specify with standard height seating (17"-18" seat heights).



Product Details – Jive Tables

Dual Disc Base – Rectangle (Top)

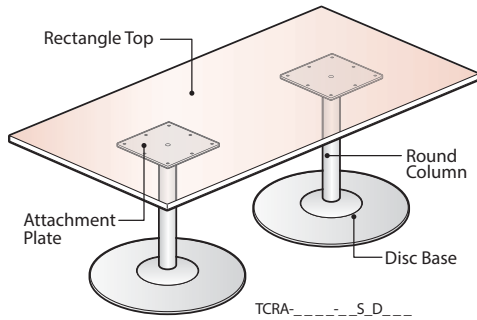

Wood Grain Direction

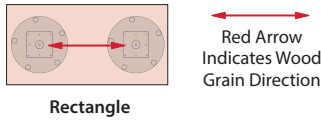

Top Cutout Options

- Power and Data access may be provided by specifying optional factory installed cutouts.
- Cutouts are designed to accommodate separately specified Flip Top Units.

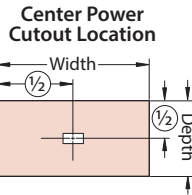

N No Cutout

F Center Power Cutout for 4-Port Single Sided Flip Top Unit

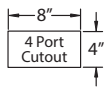

J Center Power Cutout for 6-Port Single Sided Flip Top Unit

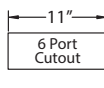

M Center Power Cutout for 8-Port Double Sided Flip Top Unit

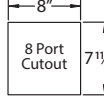

Q Center Power Cutout for 12-Port Double Sided Flip Top Unit

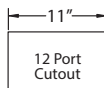

Base & Wire Management Options

Base - No Power

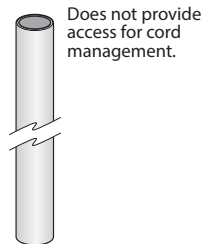

Base - Power Ready

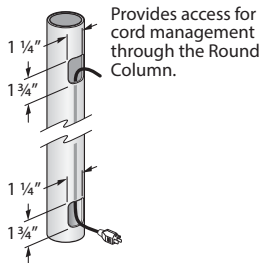

Component Materials/Finishes

COMPONENT NAME		MATERIALS/ FINISHES
Rectangle Top	Edge option (Knife or Edgeband) is applied to all edges.	(L) Laminate – Specify separate top and edge finish colors. (W) Wood – Specify a single finish color for top and edge.
		(J) Edgeband (F) Knife (K) Edgeband (U) Knife
Disc Base	Disc Base, Round Column and Attachment Plates	Painted – Specify Base Trim Color
	Glides (Non-Adjustable)	Standard In Black.

Sizes and Dimensions

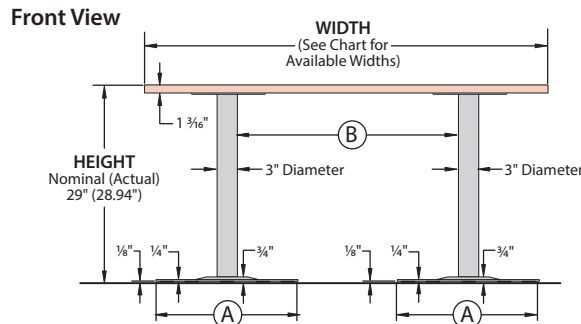
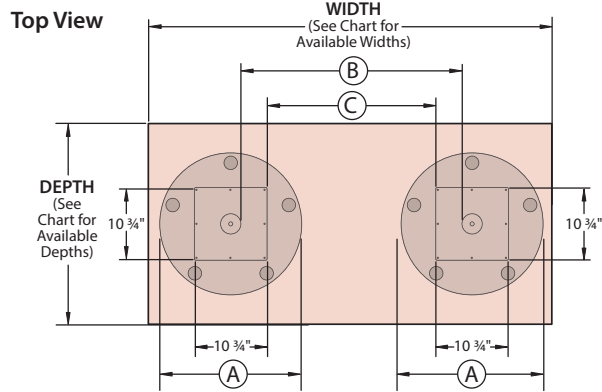

HEIGHT Nominal (Actual)	DEPTH Nominal (Actual)	WIDTH Nominal (Actual)	Component Dimensions		
			A	B	C
29" (28.94")	30" (29.68")	60" (59.68")	21"	30"	20 1/2"
		72" (71.68")	21"	42"	32 1/2"
	36" (35.68")	72" (71.68")	27 3/8"	33"	26 1/2"
		84" (83.68")	27 3/8"	48"	38 1/2"
36" (35.94")	42" (41.68")	84" (83.68")	27 3/8"	39"	32 1/2"
		96" (95.68")	27 3/8"	51"	44 1/2"
	30" (29.68")	60" (59.68")	21"	30"	20 1/2"
		72" (71.68")	21"	42"	32 1/2"
36" (35.94")	36" (35.68")	72" (71.68")	27 3/8"	33"	26 1/2"
		84" (83.68")	27 3/8"	48"	38 1/2"
	42" (41.68")	84" (83.68")	27 3/8"	39"	32 1/2"
		96" (95.68")	27 3/8"	51"	44 1/2"

Table Heights

36" High Tables

- Seated or standing applications.
- Specify with counter height stools (24"-26" seat heights).

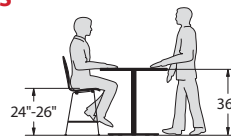

29" High Tables

- Seated applications.
- Specify with standard height seating (17"-18" seat heights).



Product Details – Jive Tables

Dual Disc Base – Racetrack (Top)

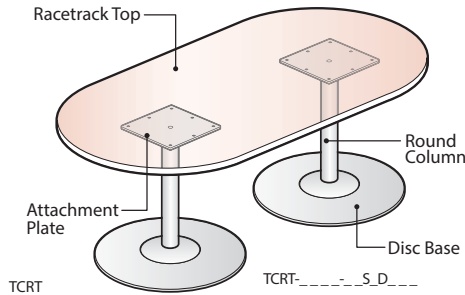

Wood Grain Direction

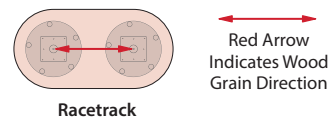

Top Cutout Options

- Power and Data access may be provided by specifying optional factory installed cutouts.
- Cutouts are designed to accommodate separately specified Flip Top Units.

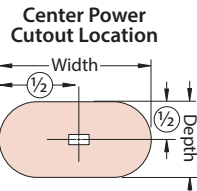

N No Cutout

F Center Power
Cutout for 4-Port Single Sided Flip Top Unit

8" x 4" Cutout

Flip Top Unit Single Sided/4 Port

EUE1

J Center Power
Cutout for 6-Port Single Sided Flip Top Unit

11" x 4" Cutout

Flip Top Unit Single Sided/6 Port

EUE1

M Center Power
Cutout for 8-Port Double Sided Flip Top Unit

8" x 7 1/16" Cutout

Flip Top Unit Double Sided/8 Port

EUE2

Q Center Power
Cutout for 12-Port Double Sided Flip Top Unit

11" x 7 1/16" Cutout

Flip Top Unit Double Sided/12 Port

EUE2

Base & Wire Management Options

Base - No Power

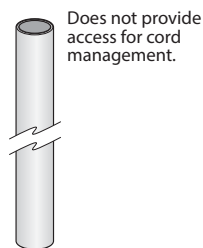

Base - Power Ready

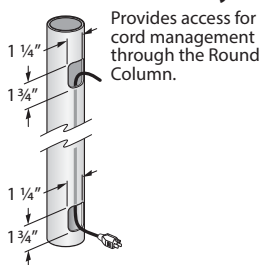

Component Materials/Finishes

COMPONENT NAME		MATERIALS/ FINISHES
Racetrack Top	Edge option (Knife or Edgeband) is applied to all edges.	(L) Laminate – Specify separate top and edge finish colors.
		(W) Wood – Specify a single finish color for top and edge.
Disc Base	Disc Base, Round Column and Attachment Plates	Painted – Specify Base Trim Color
	Glides (Non-Adjustable)	Standard In Black.

Sizes and Dimensions

Top View

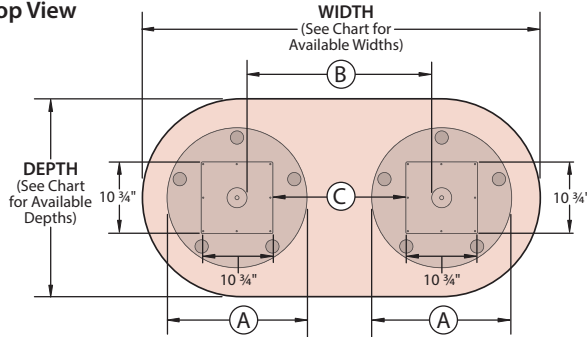

Front View

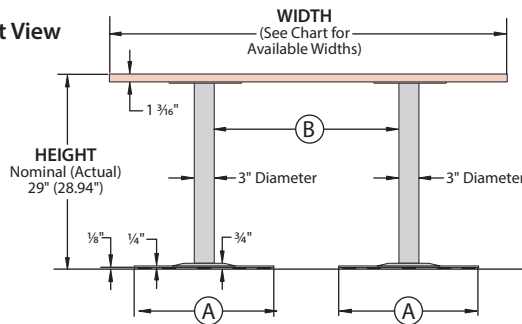

HEIGHT Nominal (Actual)	DEPTH Nominal (Actual)	WIDTH Nominal (Actual)	Component Dimensions		
			A	B	C
29" (28.94")	30" (29.68")	60" (59.68")	21"	30"	20 1/2"
		72" (71.68")	21"	36"	26 1/2"
	72" (71.68")	27 3/8"	36"	26 1/2"	
	84" (83.68")	27 3/8"	42"	32 1/2"	
	84" (83.68")	27 3/8"	42"	32 1/2"	
36" (35.94")	30" (29.68")	60" (59.68")	21"	30"	20 1/2"
		72" (71.68")	21"	36"	26 1/2"
	72" (71.68")	27 3/8"	36"	26 1/2"	
	84" (83.68")	27 3/8"	42"	32 1/2"	
	84" (83.68")	27 3/8"	42"	32 1/2"	

Table Heights

36" High Tables

- Seated or standing applications.
- Specify with counter height stools (24"-26" seat heights).

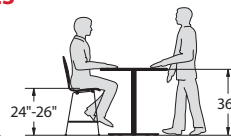

29" High Tables

- Seated applications.
- Specify with standard height seating (17"-18" seat heights).



Product Details – Jive Tables

T-Leg – Extruded (Column) – Rectangle (Top)

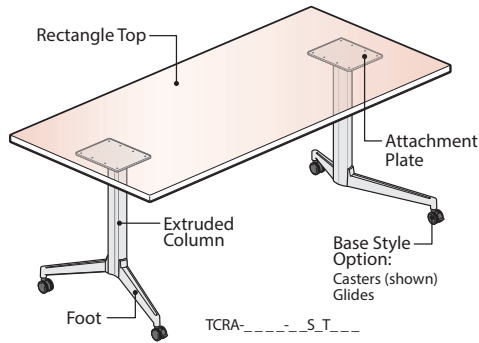

Component Materials/Finishes

COMPONENT NAME		MATERIALS/ FINISHES
Rectangle Top	Edge option (Knife or Edgeband) is applied to all edges.	(L) Laminate – Specify separate top and edge finish colors.
		(J) Edgeband
T-Leg Extruded Base	Feet and Columns	(W) Wood – Specify a single finish color for top and edge.
		(F) Knife
T-Leg Extruded Base	Attachment Plates	(K) Edgeband
		(U) Knife
T-Leg Extruded Base	Base Style	(A) Painted – The Foot, Column, Post Leg and Attachment Plate are painted metal, specify base trim color.
		(B) Polished – The Foot is polished aluminum. The Column is painted metal with a specified base trim color.
T-Leg Extruded Base	Casters	Painted Metal – Standard in black.
		Glides – Standard in black.

Wood Grain Direction

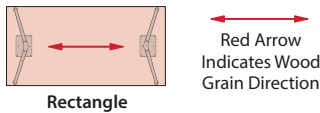

Top Cutout Options

- Power and Data access may be provided by specifying optional factory installed cutouts.
- Cutouts are designed to accommodate separately specified Flip Top Units.

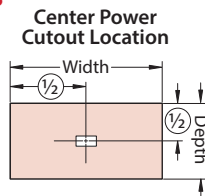

N No Cutout

F Center Power Cutout for 4-Port Single Sided Flip Top Unit

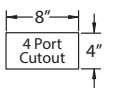

J Center Power Cutout for 6-Port Single Sided Flip Top Unit

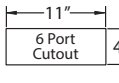

Base & Wire Management Options

Base - No Power

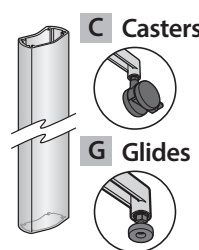

Does not provide access for cord management.

Base - Power Ready

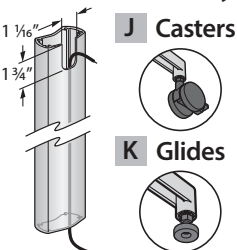

Provides access for cord management through (1) of the Post Extruded Legs. Power ready leg location determined during installation.

- Note**
- Only the 29" high Tables may be specified with the caster option. 42" and 36" high Tables are standard with Glides only.
 - Casters and glides are not interchangeable.

Sizes and Dimensions

Top View

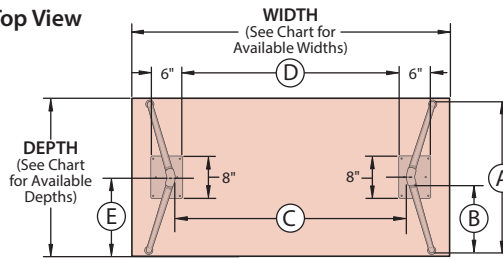

Front View with Glides

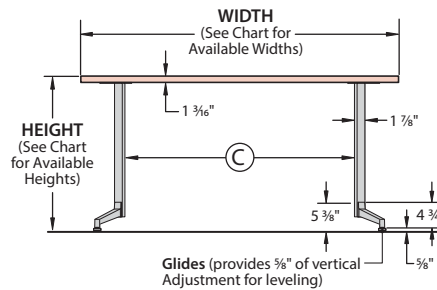

Side View with Glides

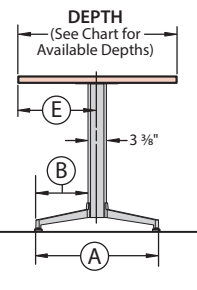

Front View with Casters

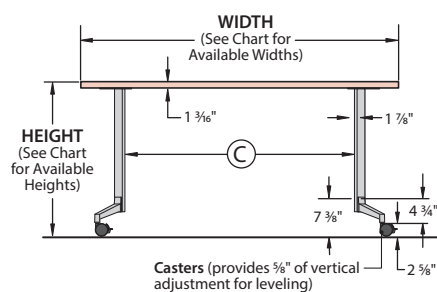

Side View with Casters

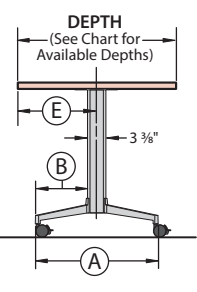

Note • See the following page for the sizes and dimensions chart.

Table Heights

42" High Tables

- Seated or standing applications.
- Specify with bar height stools (28"-30" seat heights).

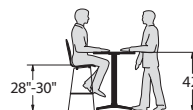

36" High Tables

- Seated or standing applications.
- Specify with counter height stools (24"-26" seat heights).



29" High Tables

- Seated applications.
- Specify with standard height seating (17"-18" seat heights).



Product Details – Jive Tables

T-Leg – Extruded (Column) – Rectangle (Top)

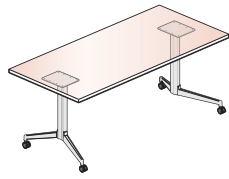

Sizes and Dimensions

HEIGHT Nominal (Actual)	DEPTH Nominal (Actual)	WIDTH Nominal (Actual)	Component Dimensions					Caster/Glide Availability		
			(A)	(B)	(C)	(D)	(E)	Casters	Glides	
29" (28.94")	18" (17.68")	48" (47.68")	17 3/8"	7"	31 7/16"	28 13/16"	8 13/16"	Yes	Yes	
		54" (53.68")	17 3/8"	7"	37 7/16"	34 13/16"	8 13/16"	Yes	Yes	
		60" (59.68")	17 3/8"	7"	43 7/16"	40 13/16"	8 13/16"	Yes	Yes	
		66" (65.68")	17 3/8"	7"	49 7/16"	46 13/16"	8 13/16"	Yes	Yes	
		72" (71.68")	17 3/8"	7"	55 7/16"	52 13/16"	8 13/16"	Yes	Yes	
	24" (23.68")	36" (35.68")	23 3/16"	9 7/8"	19 7/16"	16 13/16"	11 13/16"	Yes	Yes	
		42" (41.68")	23 3/16"	9 7/8"	25 7/16"	22 13/16"	11 13/16"	Yes	Yes	
		48" (47.68")	23 3/16"	9 7/8"	31 7/16"	26 13/16"	11 13/16"	Yes	Yes	
		54" (53.68")	23 3/16"	9 7/8"	37 7/16"	34 13/16"	11 13/16"	Yes	Yes	
		60" (59.68")	23 3/16"	9 7/8"	43 7/16"	40 13/16"	11 13/16"	Yes	Yes	
		66" (65.68")	23 3/16"	9 7/8"	49 7/16"	46 13/16"	11 13/16"	Yes	Yes	
	30" (29.68")	72" (71.68")	23 3/16"	9 7/8"	55 7/16"	52 13/16"	11 13/16"	Yes	Yes	
		36" (35.68")	28 15/16"	12 3/4"	19 7/16"	16 13/16"	14 13/16"	Yes	Yes	
		42" (41.68")	28 15/16"	12 3/4"	25 7/16"	22 13/16"	14 13/16"	Yes	Yes	
		48" (47.68")	28 15/16"	12 3/4"	31 7/16"	26 13/16"	14 13/16"	Yes	Yes	
		54" (53.68")	28 15/16"	12 3/4"	37 7/16"	34 13/16"	14 13/16"	Yes	Yes	
		60" (59.68")	28 15/16"	12 3/4"	43 7/16"	40 13/16"	14 13/16"	Yes	Yes	
	36" (35.68")	66" (65.68")	28 15/16"	12 3/4"	49 7/16"	46 13/16"	14 13/16"	Yes	Yes	
		72" (71.68")	28 15/16"	12 3/4"	55 7/16"	52 13/16"	14 13/16"	Yes	Yes	
		60" (59.68")	31 7/8"	14 1/4"	43 7/16"	43 13/16"	17 13/16"	Yes	Yes	
	36" (35.94")	24" (23.68")	36" (35.68")	23 3/16"	9 7/8"	19 7/16"	16 13/16"	11 13/16"	No	Yes
			42" (41.68")	23 3/16"	9 7/8"	25 7/16"	22 13/16"	11 13/16"	No	Yes
			48" (47.68")	23 3/16"	9 7/8"	31 7/16"	26 13/16"	11 13/16"	No	Yes
			54" (53.68")	23 3/16"	9 7/8"	37 7/16"	34 13/16"	11 13/16"	No	Yes
60" (59.68")			23 3/16"	9 7/8"	43 7/16"	40 13/16"	11 13/16"	No	Yes	
66" (65.68")			23 3/16"	9 7/8"	49 7/16"	46 13/16"	11 13/16"	No	Yes	
30" (29.68")		72" (71.68")	23 3/16"	9 7/8"	55 7/16"	52 13/16"	11 13/16"	No	Yes	
		36" (35.68")	28 15/16"	12 3/4"	19 7/16"	16 13/16"	14 13/16"	No	Yes	
		42" (41.68")	28 15/16"	12 3/4"	25 7/16"	22 13/16"	14 13/16"	No	Yes	
		48" (47.68")	28 15/16"	12 3/4"	31 7/16"	26 13/16"	14 13/16"	No	Yes	
		54" (53.68")	28 15/16"	12 3/4"	37 7/16"	34 13/16"	14 13/16"	No	Yes	
		60" (59.68")	28 15/16"	12 3/4"	43 7/16"	40 13/16"	14 13/16"	No	Yes	
36" (35.68")		66" (65.68")	28 15/16"	12 3/4"	49 7/16"	46 13/16"	14 13/16"	No	Yes	
		72" (71.68")	28 15/16"	12 3/4"	55 7/16"	52 13/16"	14 13/16"	No	Yes	
42" (41.94")		24" (23.68")	36" (35.68")	23 3/16"	9 7/8"	19 7/16"	16 13/16"	11 13/16"	No	Yes
			42" (41.68")	23 3/16"	9 7/8"	25 7/16"	22 13/16"	11 13/16"	No	Yes
			48" (47.68")	23 3/16"	9 7/8"	31 7/16"	26 13/16"	11 13/16"	No	Yes
			54" (53.68")	23 3/16"	9 7/8"	37 7/16"	34 13/16"	11 13/16"	No	Yes
			60" (59.68")	23 3/16"	9 7/8"	43 7/16"	40 13/16"	11 13/16"	No	Yes
			66" (65.68")	23 3/16"	9 7/8"	49 7/16"	46 13/16"	11 13/16"	No	Yes
		30" (29.68")	72" (71.68")	23 3/16"	9 7/8"	55 7/16"	52 13/16"	11 13/16"	No	Yes
			36" (35.68")	28 15/16"	12 3/4"	19 7/16"	16 13/16"	14 13/16"	No	Yes
			42" (41.68")	28 15/16"	12 3/4"	25 7/16"	22 13/16"	14 13/16"	No	Yes
			48" (47.68")	28 15/16"	12 3/4"	31 7/16"	26 13/16"	14 13/16"	No	Yes
	54" (53.68")		28 15/16"	12 3/4"	37 7/16"	34 13/16"	14 13/16"	No	Yes	
	60" (59.68")		28 15/16"	12 3/4"	43 7/16"	40 13/16"	14 13/16"	No	Yes	
	36" (35.68")	66" (65.68")	28 15/16"	12 3/4"	49 7/16"	46 13/16"	14 13/16"	No	Yes	
		72" (71.68")	28 15/16"	12 3/4"	55 7/16"	52 13/16"	14 13/16"	No	Yes	

Product Details – Jive Tables

T-Leg – Extruded (Column) – Pebble (Top)

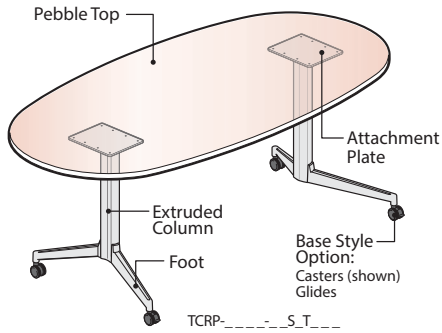

Component Materials/Finishes

COMPONENT NAME		MATERIALS/ FINISHES
Pebble Top	Edge option (Knife or Edgeband) is applied to all edges.	(L) Laminate – Specify separate top and edge finish colors.
		(W) Wood – Specify a single finish color for top and edge.
T-Leg Extruded Base	Feet and Columns	(A) Painted – The Foot, Column, Post Leg and Attachment Plate are painted metal, specify base trim color. (B) Polished – The Foot is polished aluminum. The Column is painted metal with a specified base trim color.
	Attachment Plates	Painted Metal – Standard in black.
	Base Style	Casters – Standard in black. Glides – Standard in black.

Wood Grain Direction

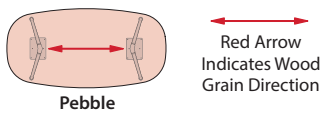

Top Cutout Options

- Power and Data access may be provided by specifying optional factory installed cutouts.
- Cutouts are designed to accommodate separately specified Flip Top Units.

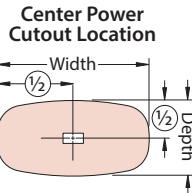

N No Cutout

F Center Power
Cutout for 4-Port Single Sided Flip Top Unit

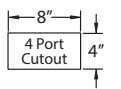

J Center Power
Cutout for 6-Port Single Sided Flip Top Unit

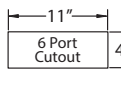

Base & Wire Management Options

Base - No Power

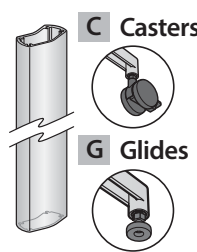

Does not provide access for cord management.

Base - Power Ready

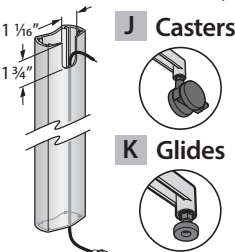

Provides access for cord management through (1) of the Post Extruded Legs. Power ready leg location determined during installation.

Note • Casters and glides are not interchangeable.

Table Heights

29" High Tables

- Seated applications.
- Specify with standard height seating (17"-18" seat heights).



Sizes and Dimensions

Top View

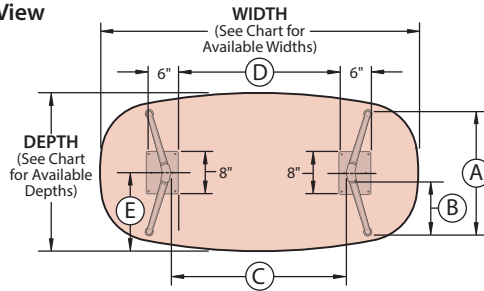

Front View with Glides

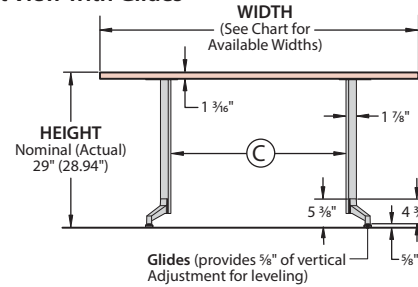

Side View with Glides

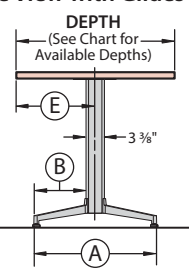

Front View with Casters

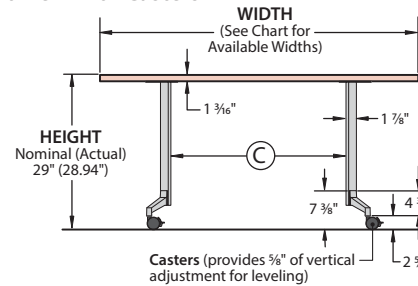

Side View with Casters

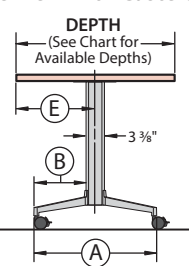

HEIGHT Nominal (Actual)	DEPTH Nominal (Actual)	WIDTH Nominal (Actual)	T-Leg Base / Pebble Top					Caster/Glide Availability	
			A	B	C	D	E	Casters	Glides
29" (28.94")	30" (23.68")	48" (47.68")	23 3/16"	9 7/8"	22 7/16"	19 13/16"	14 13/16"	Yes	Yes
		60" (59.68")	23 3/16"	9 7/8"	34 7/16"	31 13/16"	14 13/16"	Yes	Yes
	36" (35.68")	72" (71.68")	23 3/16"	9 7/8"	46 7/16"	43 13/16"	17 13/16"	Yes	Yes
		72" (71.68")	28 13/16"	12 3/4"	34 7/16"	31 13/16"	17 13/16"	Yes	Yes

Product Details – Jive Tables

T-Leg – Extruded (Column) – Racetrack (Top)

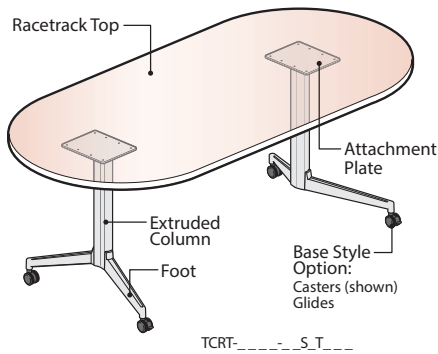

Component Materials/Finishes

COMPONENT NAME		MATERIALS/ FINISHES
Racetrack Top	Edge option (Knife or Edgeband) is applied to all edges.	(L) Laminate – Specify separate top and edge finish colors.
		(J) Edgeband
T-Leg Extruded Base	Feet and Columns	(W) Wood – Specify a single finish color for top and edge.
		(F) Knife
Attachment Plates	Base Style	(A) Painted – The Foot, Column, Post Leg and Attachment Plate are painted metal, specify base trim color.
		(B) Polished – The Foot is polished aluminum. The Column is painted metal with a specified base trim color.
Attachment Plates	Base Style	(K) Edgeband
		(U) Knife
Attachment Plates	Base Style	Painted Metal – Standard in black.
		Casters – Standard in black.
Attachment Plates	Base Style	Glides – Standard in black.

Wood Grain Direction

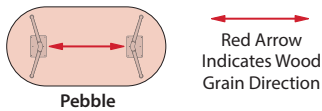

Top Cutout Options

- Power and Data access may be provided by specifying optional factory installed cutouts.
- Cutouts are designed to accommodate separately specified Flip Top Units.

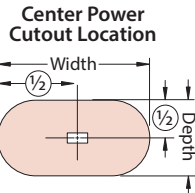

N No Cutout

- F Center Power**
Cutout for 4-Port Single Sided Flip Top Unit

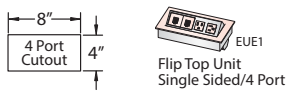

- J Center Power**
Cutout for 6-Port Single Sided Flip Top Unit

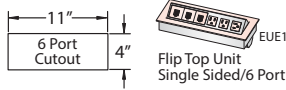

Base & Wire Management Options

Base - No Power

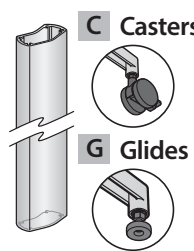

Does not provide access for cord management.

Base - Power Ready

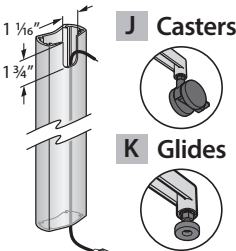

Provides access for cord management through (1) of the Post Extruded Legs. Power ready leg location determined during installation.

Note • Casters and glides are not interchangeable.

Table Heights

29" High Tables

- Seated applications.
- Specify with standard height seating (17"-18" seat heights).



Sizes and Dimensions

Top View

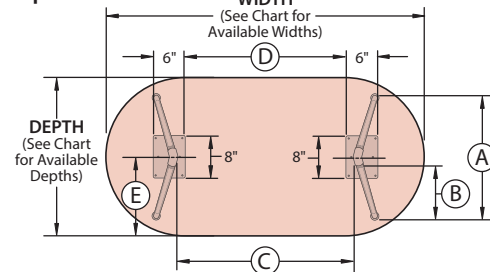

Front View with Glides

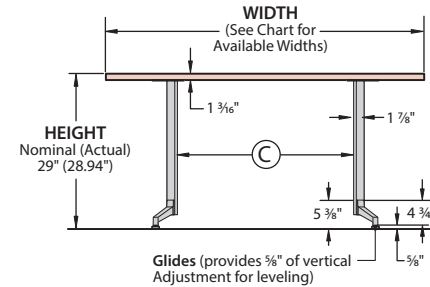

Side View with Glides

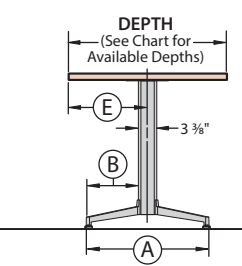

Front View with Casters

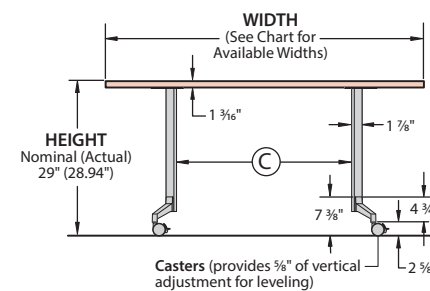

Side View with Casters

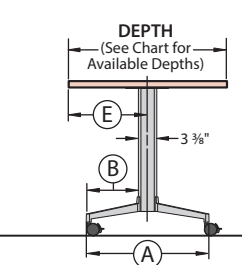

HEIGHT Nominal (Actual)	DEPTH Nominal (Actual)	WIDTH Nominal (Actual)	T-Leg Base / Pebble Top					Caster/Glide Availability	
			(A)	(B)	(C)	(D)	(E)	Casters	Glides
29" (28.94")	30" (23.68")	48" (47.68")	23 3/16"	9 7/8"	16 3/4"	14"	14 13/16"	Yes	Yes
		60" (59.68")	23 3/16"	9 7/8"	28 3/4"	26"	14 13/16"	Yes	Yes
	72" (71.68")	23 3/16"	9 7/8"	40 3/4"	38"	14 13/16"	Yes	Yes	
36" (35.68")	60" (59.68")	28 15/16"	12 3/4"	28 3/4"	26"	17 13/16"	Yes	Yes	
	72" (71.68")	28 15/16"	12 3/4"	40 3/4"	38"	17 13/16"	Yes	Yes	

Product Details – Jive Tables

T-Leg – Extruded (Column) – Trapezoid (Top)

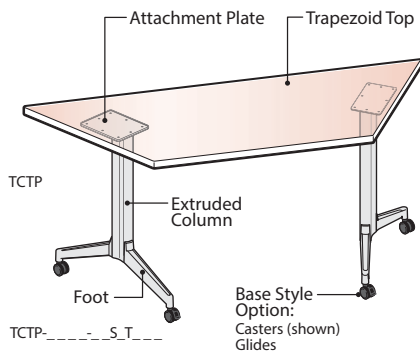

Component Materials/Finishes

COMPONENT NAME		MATERIALS/ FINISHES
Trapezoid Top	Edge option (Knife or Edgeband) is applied to all edges.	(L) Laminate – Specify separate top and edge finish colors.
		(W) Wood – Specify a single finish color for top and edge.
T-Leg Extruded Base	Feet and Columns	(J) Edgeband (F) Knife (K) Edgeband (U) Knife
		(A) Painted – The Foot, Column, Post Leg and Attachment Plate are painted metal, specify base trim color. (B) Polished – The Foot is polished aluminum. The Column is painted metal with a specified base trim color.
	Attachment Plates	Painted Metal – Standard in black.
	Base Style	Casters – Standard in black. Glides – Standard in black.

Wood Grain Direction

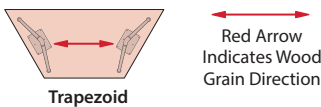

Top Cutout Options

- Power and Data access may be provided by specifying optional factory installed cutouts.
- Cutouts are designed to accommodate separately specified Flip Top Units.

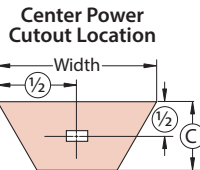

N No Cutout

F Center Power Cutout for 4-Port Single Sided Flip Top Unit

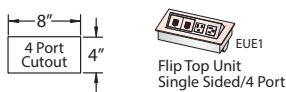

J Center Power Cutout for 6-Port Single Sided Flip Top Unit

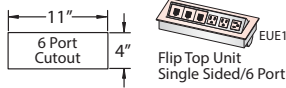

Base & Wire Management Options

Base - No Power

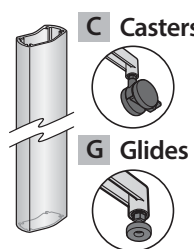

Does not provide access for cord management.

Base - Power Ready

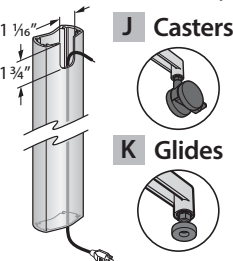

Provides access for cord management through (1) of the Post Extruded Legs. Power ready leg location determined during installation.

Note • Casters and glides are not interchangeable.

Table Heights

29" High Tables

- Seated applications.
- Specify with standard height seating (17"-18" seat heights).



Sizes and Dimensions

Top View

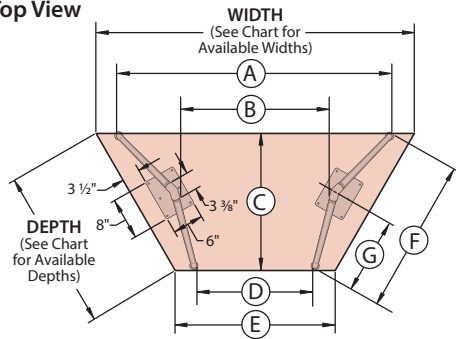

Front View with Glides

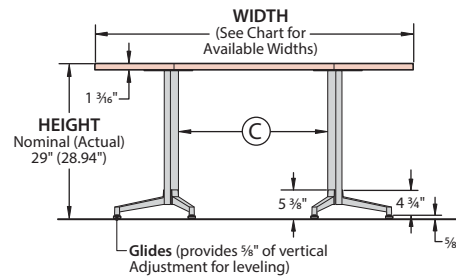

Side View with Glides

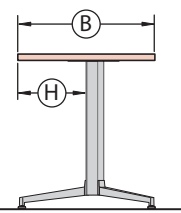

Front View with Casters

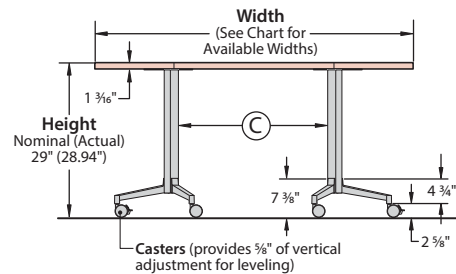

Side View with Casters

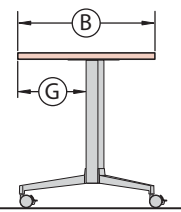

HEIGHT Nominal (Actual)	DEPTH Nominal (Actual)	WIDTH Nominal (Actual)	Component Dimensions								Caster/Glide Availability	
			A	B	C	D	E	F	G	H	Casters	Glides
29" (28.94")	24" (23.68")	48" (47.68")	37 7/8"	20 1/2"	20 1/2"	18 1/2"	24"	23 1/8"	11 1/16"	7 1/16"	Yes	Yes
		54" (53.68")	43 7/8"	20 1/2"	20 1/2"	24 1/2"	30"	23 1/8"	11 1/16"	7 1/16"	Yes	Yes
		60" (59.68")	49 7/8"	20 1/2"	20 1/2"	30 1/2"	36"	23 1/8"	11 1/16"	7 1/16"	Yes	Yes
		66" (65.68")	55 7/8"	20 1/2"	20 1/2"	36 1/2"	42"	23 1/8"	11 1/16"	7 1/16"	Yes	Yes
29" (28.94")	30" (29.68")	72" (71.68")	61 7/8"	20 1/2"	20 1/2"	42 1/2"	48"	23 1/8"	11 1/16"	7 1/16"	Yes	Yes
		60" (59.68")	51 7/8"	25 1/16"	25 1/16"	27 1/16"	30"	28 1/16"	14 1/2"	9 1/4"	Yes	Yes
		66" (65.68")	57 7/8"	25 1/16"	25 1/16"	33 1/16"	36"	28 1/16"	14 1/2"	9 1/4"	Yes	Yes
29" (28.94")	36" (35.68")	72" (71.68")	63 7/8"	25 1/16"	25 1/16"	39 1/16"	42"	28 1/16"	14 1/2"	9 1/4"	Yes	Yes
		84" (83.68")	75 1/4"	30 7/8"	30 7/8"	49 1/2"	48"	31 7/8"	15 1/16"	11 3/8"	Yes	Yes

This page intentionally left blank.

Product Details – Jive Tables

T-Leg – Round (Column) – Rectangle (Top)

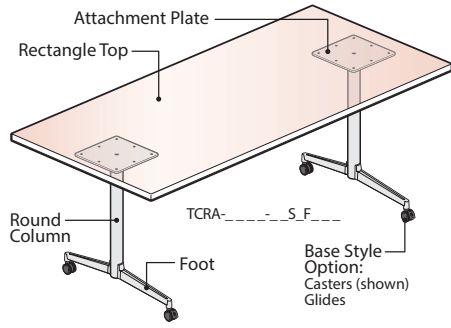

Wood Grain Direction

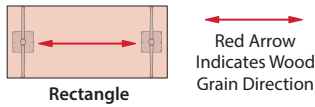

Top Cutout Options

- Power and Data access may be provided by specifying optional factory installed cutouts.
- Cutouts are designed to accommodate separately specified Flip Top Units.

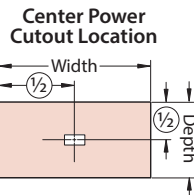

N No Cutout

F Center Power
Cutout for 4-Port Single Sided Flip Top Unit

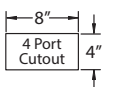

J Center Power
Cutout for 6-Port Single Sided Flip Top Unit

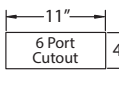

Base & Wire Management Options

Base - No Power

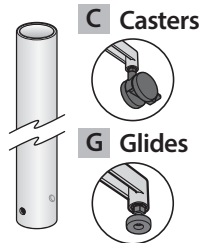

Does not provide access for cord management.

Base - Power Ready

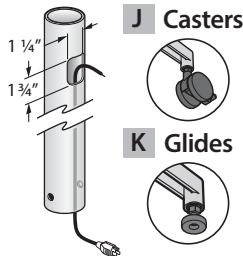

Provides access for cord management through (1) of the Round Column. Power ready leg location determined during installation.

Note

- Only the 29" high Tables may be specified with the caster option. 42" high Tables are standard with Glides only.
- Casters and glides are not interchangeable.

Component Materials/Finishes

COMPONENT NAME	MATERIALS/ FINISHES	
Rectangle Top Edge option (Knife or Edgeband) is applied to all edges.	(L) Laminate – Specify separate top and edge finish colors.	(J) Edgeband
	(W) Wood – Specify a single finish color for top and edge.	(F) Knife (K) Edgeband (U) Knife
T-Leg Round Base	(A) Painted – The Foot, Column and Attachment Plate are painted metal, specify base trim color.	
	(B) Polished – The Foot is polished aluminum. Column and Attachment Plate are painted metal, specify base trim color.	
Base Style	Casters – Standard in black.	
	Glides – Standard in black.	

Sizes and Dimensions

Top View

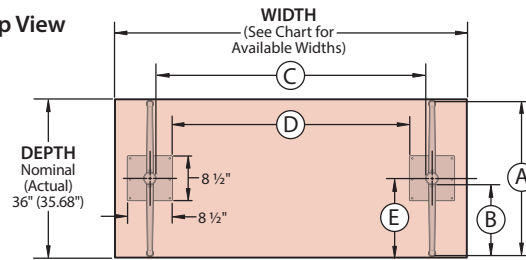

Front View with Glides

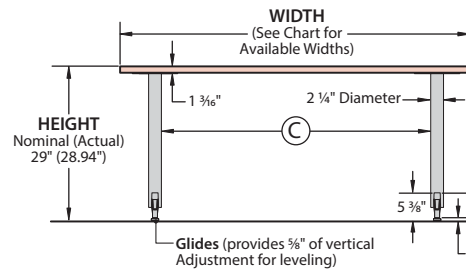

Side View with Glides

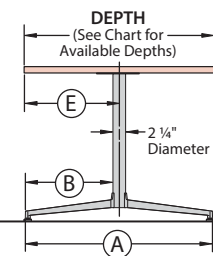

Front View with Casters

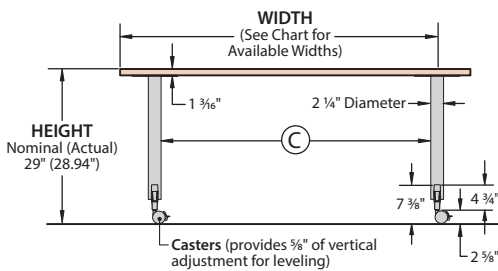

Side View with Casters

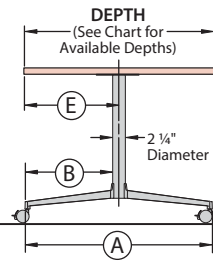

Note • See the following page for the sizes and dimensions chart.

Table Heights

42" High Tables

- Seated or standing applications.
- Specify with bar height stools (28"-30" seat heights).

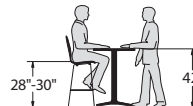

36" High Tables

- Seated or standing applications.
- Specify with counter height stools (24"-26" seat heights).



29" High Tables

- Seated applications.
- Specify with standard height seating (17"-18" seat heights).



Product Details – Jive Tables

T-Leg – Extruded (Column) – Rectangle (Top)

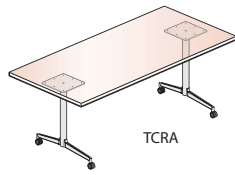

Sizes and Dimensions

HEIGHT Nominal (Actual)	DEPTH Nominal (Actual)	WIDTH Nominal (Actual)	Component Dimensions					Caster/Glide Availability		
			(A)	(B)	(C)	(D)	(E)	Casters	Glides	
29" (28.94")	18" (17.68")	48" (47.68")	16 7/8"	7 1/4"	32 3/16"	26 3/16"	8 13/16"	Yes	Yes	
		54" (53.68")	16 7/8"	7 1/4"	38 7/16"	32 3/16"	8 13/16"	Yes	Yes	
		60" (59.68")	16 7/8"	7 1/4"	44 7/16"	38 3/16"	8 13/16"	Yes	Yes	
		66" (65.68")	16 7/8"	7 1/4"	50 7/16"	44 3/16"	8 13/16"	Yes	Yes	
		72" (71.68")	16 7/8"	7 1/4"	56 7/16"	50 3/16"	8 13/16"	Yes	Yes	
	24" (23.68")	36" (35.68")	22 7/8"	10 1/4"	20 7/16"	14 3/16"	11 13/16"	Yes	Yes	
		42" (41.68")	22 7/8"	10 1/4"	26 7/16"	20 3/16"	11 13/16"	Yes	Yes	
		48" (47.68")	22 7/8"	10 1/4"	32 7/16"	26 3/16"	11 13/16"	Yes	Yes	
		54" (53.68")	22 7/8"	10 1/4"	38 7/16"	32 3/16"	11 13/16"	Yes	Yes	
		60" (59.68")	22 7/8"	10 1/4"	44 7/16"	38 3/16"	11 13/16"	Yes	Yes	
		66" (65.68")	22 7/8"	10 1/4"	50 7/16"	44 3/16"	11 13/16"	Yes	Yes	
	30" (29.68")	36" (35.68")	28 7/8"	13 1/4"	20 7/16"	14 3/16"	14 13/16"	Yes	Yes	
		42" (41.68")	28 7/8"	13 1/4"	26 7/16"	20 3/16"	14 13/16"	Yes	Yes	
		48" (47.68")	28 7/8"	13 1/4"	32 7/16"	26 3/16"	14 13/16"	Yes	Yes	
		54" (53.68")	28 7/8"	13 1/4"	38 7/16"	32 3/16"	14 13/16"	Yes	Yes	
		60" (59.68")	28 7/8"	13 1/4"	44 7/16"	38 3/16"	14 13/16"	Yes	Yes	
	36" (35.68")	66" (65.68")	28 7/8"	13 1/4"	50 7/16"	44 3/16"	14 13/16"	Yes	Yes	
		72" (71.68")	28 7/8"	13 1/4"	56 7/16"	50 3/16"	14 13/16"	Yes	Yes	
		60" (59.68")	31 3/4"	14 11/16"	44 7/16"	38 3/16"	17 13/16"	Yes	Yes	
		66" (65.68")	31 3/4"	14 11/16"	50 7/16"	44 3/16"	17 13/16"	Yes	Yes	
	36" (35.94")	24" (23.68")	36" (35.68")	22 7/8"	10 1/4"	20 7/16"	14 3/16"	11 13/16"	No	Yes
			42" (41.68")	22 7/8"	10 1/4"	26 7/16"	20 3/16"	11 13/16"	No	Yes
			48" (47.68")	22 7/8"	10 1/4"	32 7/16"	26 3/16"	11 13/16"	No	Yes
			54" (53.68")	22 7/8"	10 1/4"	38 7/16"	32 3/16"	11 13/16"	No	Yes
60" (59.68")			22 7/8"	10 1/4"	44 7/16"	38 3/16"	11 13/16"	No	Yes	
66" (65.68")			22 7/8"	10 1/4"	50 7/16"	44 3/16"	11 13/16"	No	Yes	
30" (29.68")		72" (71.68")	22 7/8"	10 1/4"	56 7/16"	50 3/16"	11 13/16"	No	Yes	
		36" (35.68")	28 7/8"	13 1/4"	20 7/16"	14 3/16"	14 13/16"	No	Yes	
		42" (41.68")	28 7/8"	13 1/4"	26 7/16"	20 3/16"	14 13/16"	No	Yes	
		48" (47.68")	28 7/8"	13 1/4"	32 7/16"	26 3/16"	14 13/16"	No	Yes	
		54" (53.68")	28 7/8"	13 1/4"	38 7/16"	32 3/16"	14 13/16"	No	Yes	
36" (35.68")		60" (59.68")	28 7/8"	13 1/4"	44 7/16"	38 3/16"	14 13/16"	No	Yes	
		66" (65.68")	28 7/8"	13 1/4"	50 7/16"	44 3/16"	14 13/16"	No	Yes	
		72" (71.68")	28 7/8"	13 1/4"	56 7/16"	50 3/16"	14 13/16"	No	Yes	
42" (41.94")	24" (23.68")	66" (65.68")	31 3/4"	14 11/16"	50 7/16"	44 3/16"	17 13/16"	No	Yes	
		72" (71.68")	31 3/4"	14 11/16"	56 7/16"	50 3/16"	17 13/16"	No	Yes	
		36" (35.68")	22 7/8"	10 1/4"	20 7/16"	14 3/16"	11 13/16"	No	Yes	
		42" (41.68")	22 7/8"	10 1/4"	26 7/16"	20 3/16"	11 13/16"	No	Yes	
		48" (47.68")	22 7/8"	10 1/4"	32 7/16"	26 3/16"	11 13/16"	No	Yes	
		54" (53.68")	22 7/8"	10 1/4"	38 7/16"	32 3/16"	11 13/16"	No	Yes	
		60" (59.68")	22 7/8"	10 1/4"	44 7/16"	38 3/16"	11 13/16"	No	Yes	
	30" (29.68")	66" (65.68")	22 7/8"	10 1/4"	50 7/16"	44 3/16"	11 13/16"	No	Yes	
		72" (71.68")	22 7/8"	10 1/4"	56 7/16"	50 3/16"	11 13/16"	No	Yes	
		36" (35.68")	28 7/8"	13 1/4"	20 7/16"	14 3/16"	14 13/16"	No	Yes	
		42" (41.68")	28 7/8"	13 1/4"	26 7/16"	20 3/16"	14 13/16"	No	Yes	
		48" (47.68")	28 7/8"	13 1/4"	32 7/16"	26 3/16"	14 13/16"	No	Yes	
		54" (53.68")	28 7/8"	13 1/4"	38 7/16"	32 3/16"	14 13/16"	No	Yes	
	36" (35.68")	60" (59.68")	28 7/8"	13 1/4"	44 7/16"	38 3/16"	14 13/16"	No	Yes	
		66" (65.68")	28 7/8"	13 1/4"	50 7/16"	44 3/16"	14 13/16"	No	Yes	
		72" (71.68")	28 7/8"	13 1/4"	56 7/16"	50 3/16"	14 13/16"	No	Yes	
		66" (65.68")	31 3/4"	14 11/16"	50 7/16"	44 3/16"	17 13/16"	No	Yes	
		72" (71.68")	31 3/4"	14 11/16"	56 7/16"	50 3/16"	17 13/16"	No	Yes	

Product Details – Jive Tables

T-Leg – Round (Column) – Pebble (Top)

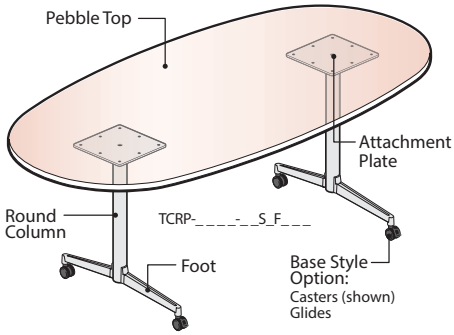

Component Materials/Finishes

COMPONENT NAME		MATERIALS/ FINISHES
Pebble Top	Edge option (Knife or Edgeband) is applied to all edges.	(L) Laminate – Specify separate top and edge finish colors.
		(W) Wood – Specify a single finish color for top and edge.
T-Leg Round Base	Feet, Columns and Attachment Plates	(A) Painted – The Foot, Column, Post Leg and Attachment Plate are painted metal, specify base trim color.
		(B) Polished – The Foot is polished aluminum. The Attachment Plate is painted metal standard in black. The Column is painted metal with a specified base trim color.
Base Style	Base Style	Casters – Standard in black.
		Glides – Standard in black.

Wood Grain Direction

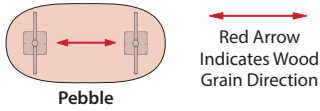

Top Cutout Options

- Power and Data access may be provided by specifying optional factory installed cutouts.
- Cutouts are designed to accommodate separately specified Flip Top Units.

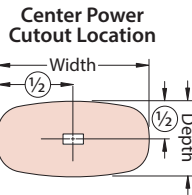

N No Cutout

F Center Power Cutout for 4-Port Single Sided Flip Top Unit

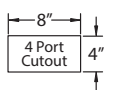

J Center Power Cutout for 6-Port Single Sided Flip Top Unit

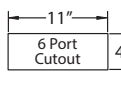

Base & Wire Management Options

Base – No Power

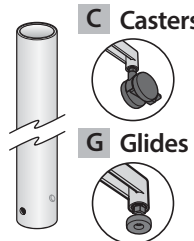

Does not provide access for cord management.

Base – Power Ready

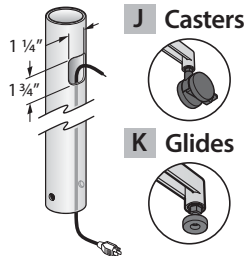

Provides access for cord management through (1) of the Round Column. Power ready leg location determined during installation.

Note • Casters and glides are not interchangeable.

Table Heights

29" High Tables

- Seated applications.
- Specify with standard height seating (17"-18" seat heights).

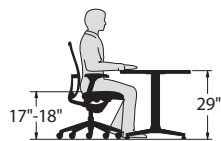

Sizes and Dimensions

Top View

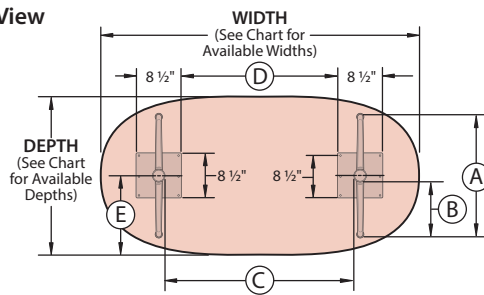

Front View with Glides

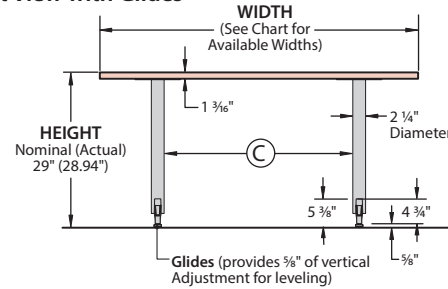

Side View with Glides

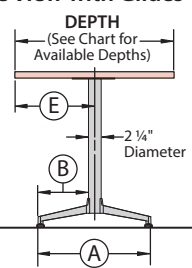

Front View with Casters

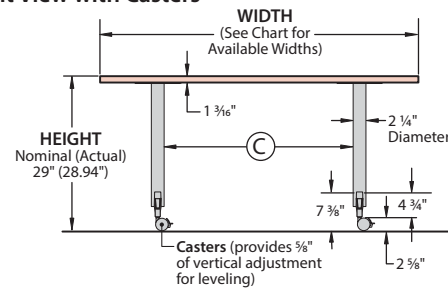

Side View with Casters

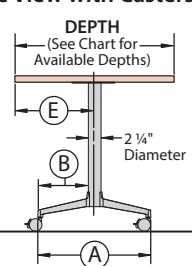

HEIGHT Nominal (Actual)	DEPTH Nominal (Actual)	WIDTH Nominal (Actual)	T-Leg Base / Pebble Top					Caster/Glide Availability	
			A	B	C	D	E	Casters	Glides
29" (28.94")	30" (23.68")	48" (47.68")	22 7/8"	10 1/4"	23 7/16"	17 3/16"	14 13/16"	Yes	Yes
		60" (59.68")	22 7/8"	10 1/4"	35 7/16"	29 3/16"	14 13/16"	Yes	Yes
	36" (35.68")	72" (71.68")	22 7/8"	10 1/4"	23 7/16"	39 5/8"	14 13/16"	Yes	Yes
		60" (59.68")	28 7/8"	13 1/4"	23 7/16"	35 3/16"	17 13/16"	Yes	Yes
		72" (71.68")	28 7/8"	13 1/4"	47 7/16"	41 3/16"	17 13/16"	Yes	Yes

Product Details – Jive Tables

T-Leg – Extruded (Column) – Racetrack (Top)

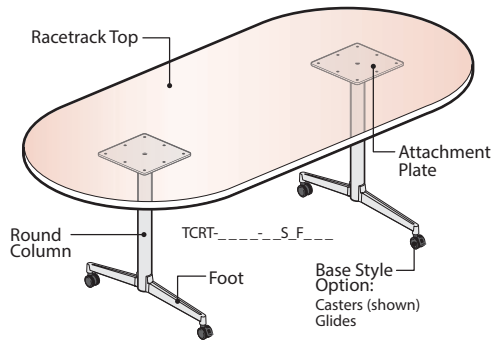

Component Materials/Finishes

COMPONENT NAME		MATERIALS/ FINISHES	
Racetrack Top	Edge option (Knife or Edgeband) is applied to all edges.	(L) Laminate – Specify separate top and edge finish colors.	(J) Edgeband
		(W) Wood – Specify a single finish color for top and edge.	(F) Knife (K) Edgeband (U) Knife
T-Leg Extruded Base	Feet, Columns and	(A) Painted – The Foot, Column, Post Leg and Attachment Plate are painted metal, specify base trim color.	(B) Polished – The Foot is polished aluminum. The Attachment Plate is painted metal standard in black. The Column is painted metal with a specified base trim color.
		Base Style	

Wood Grain Direction

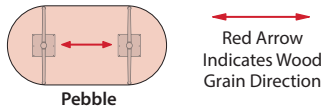

Top Cutout Options

- Power and Data access may be provided by specifying optional factory installed cutouts.
- Cutouts are designed to accommodate separately specified Flip Top Units.

Center Power Cutout Location

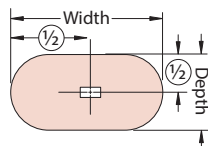

N No Cutout

F Center Power Cutout for 4-Port Single Sided Flip Top Unit

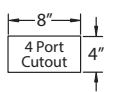

J Center Power Cutout for 6-Port Single Sided Flip Top Unit

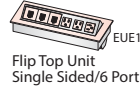
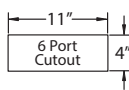

Base & Wire Management Options

Base – No Power

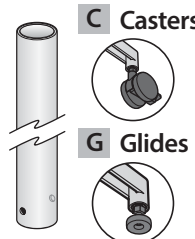

Does not provide access for cord management.

Base – Power Ready

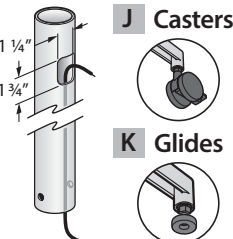

Provides access for cord management through (1) of the Round Column. Power ready leg location determined during installation.

Note • Casters and glides are not interchangeable.

Table Heights

29" High Tables

- Seated applications.
- Specify with standard height seating (17"-18" seat heights).



Sizes and Dimensions

Top View

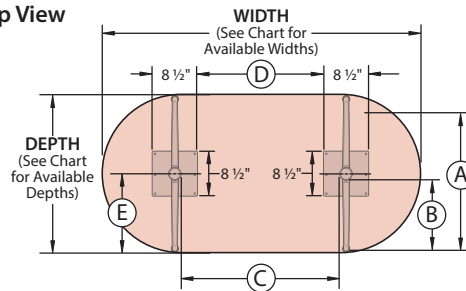

Front View with Glides

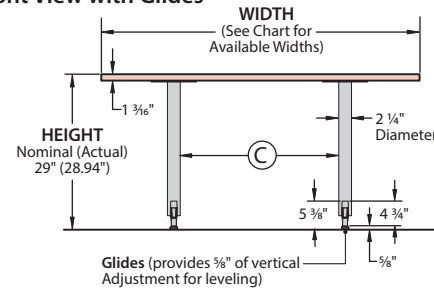

Side View with Glides

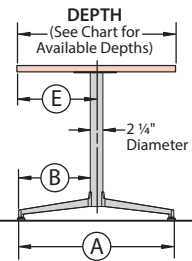

Front View with Casters

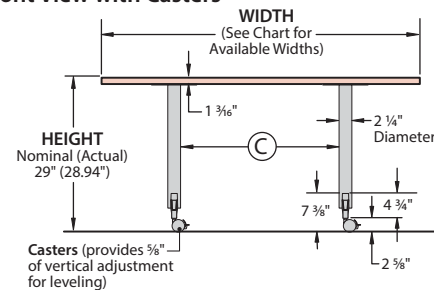

Side View with Casters

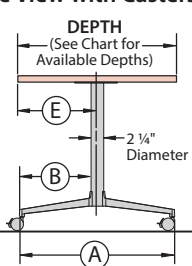

HEIGHT Nominal (Actual)	DEPTH Nominal (Actual)	WIDTH Nominal (Actual)	T-Leg Base / Pebble Top					Caster/Glide Availability	
			(A)	(B)	(C)	(D)	(E)	Casters	Glides
29" (28.94")	30" (23.68")	48" (47.68")	28 7/8"	13 1/4"	17 3/4"	14"	11 1/2"	Yes	Yes
		60" (59.68")	28 7/8"	13 1/4"	29 3/4"	26"	23 1/2"	Yes	Yes
	36" (35.68")	60" (59.68")	31 7/8"	14 3/4"	29 3/4"	26"	23 1/2"	Yes	Yes
		72" (71.68")	31 7/8"	14 3/4"	41 3/4"	38"	35 1/2"	Yes	Yes

Product Details – Jive Tables

T-Leg – Round (Column) – Trapezoid (Top)

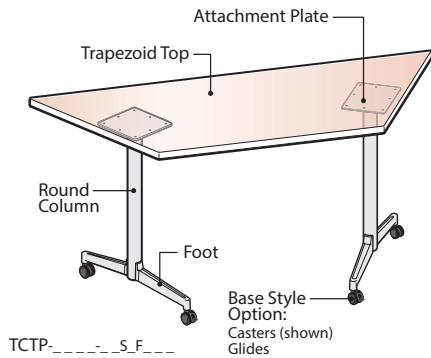

Component Materials/Finishes

COMPONENT NAME		MATERIALS/ FINISHES	
Trapezoid Top	Edge option (Knife or Edgeband) is applied to all edges.	(L) Laminate – Specify separate top and edge finish colors.	(J) Edgeband
		(W) Wood – Specify a single finish color for top and edge.	(F) Knife (K) Edgeband (U) Knife
T-Leg Round Base	Foot, Round Column and Attachment Plate	(A) Painted – The Foot, Column and Attachment Plate are painted metal, specify base trim color.	
	Base Style	(B) Polished – The Foot is polished aluminum. Column and Attachment Plate are painted metal, specify base trim color.	
		Casters – Standard in black.	
		Glides – Standard in black.	

Wood Grain Direction

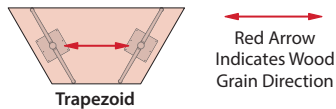

Top Cutout Options

- Power and Data access may be provided by specifying optional factory installed cutouts.
- Cutouts are designed to accommodate separately specified Flip Top Units.

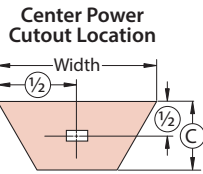

N No Cutout

F Center Power Cutout for 4-Port Single Sided Flip Top Unit

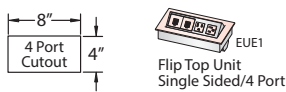

J Center Power Cutout for 6-Port Single Sided Flip Top Unit

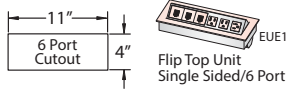

Base & Wire Management Options

Base - No Power

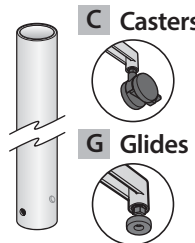

Does not provide access for cord management.

Base - Power Ready

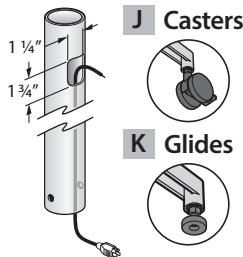

Provides access for cord management through (1) of the Round Column. Power ready leg location determined during installation.

Note • Casters and glides are not interchangeable.

Table Heights

29" High Tables

- Seated applications.
- Specify with standard height seating (17"-18" seat heights).



Sizes and Dimensions

Top View

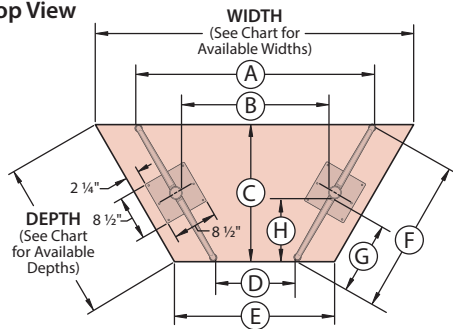

Front View with Glides

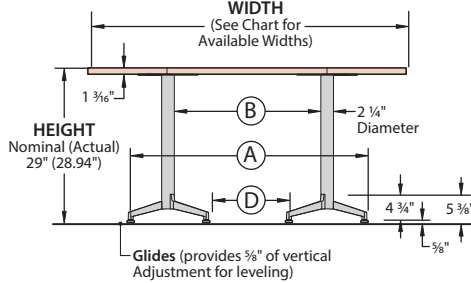

Side View with Glides

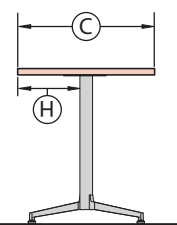

Front View with Casters

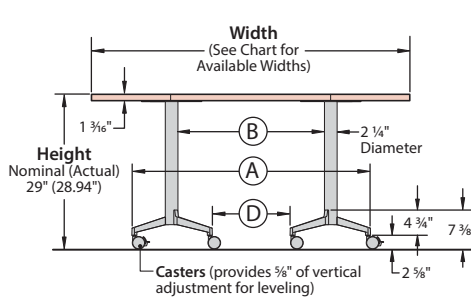

Side View with Casters

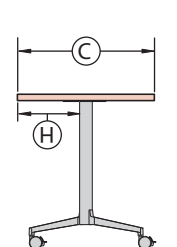

HEIGHT Nominal (Actual)	DEPTH Nominal (Actual)	WIDTH Nominal (Actual)	Component Dimensions								Caster/Glide Availability	
			A	B	C	D	E	F	G	H	Casters	Glides
29" (28.94")	24" (23.68")	48" (47.68")	32 1/16"	18 1/2"	20 1/2"	8 1/16"	24"	22 7/8"	10 1/4"	9 3/8"	Yes	Yes
		54" (53.68")	38 1/16"	24 1/2"	20 1/2"	14 1/16"	30"	22 7/8"	10 1/4"	9 3/8"	Yes	Yes
		60" (59.68")	44 1/16"	30 1/2"	20 1/2"	20 1/16"	36"	22 7/8"	10 1/4"	9 3/8"	Yes	Yes
		66" (65.68")	50 1/16"	36 1/2"	20 1/2"	26 1/16"	42"	22 7/8"	10 1/4"	9 3/8"	Yes	Yes
		72" (71.68")	56 1/16"	42 1/2"	20 1/2"	32 1/16"	48"	22 7/8"	10 1/4"	9 3/8"	Yes	Yes
30" (29.68")	24" (23.68")	60" (59.68")	44 1/16"	27 1/2"	25 1/16"	14 1/16"	30"	28 7/8"	13 1/4"	11 1/16"	Yes	Yes
		66" (65.68")	50 1/16"	33 1/2"	25 1/16"	20 1/16"	36"	28 7/8"	13 1/4"	11 1/16"	Yes	Yes
		72" (71.68")	56 1/16"	39 1/2"	25 1/16"	26 1/16"	42"	28 7/8"	13 1/4"	11 1/16"	Yes	Yes
36" (35.68")	24" (23.68")	84" (83.68")	67 1/4"	48 3/4"	30 7/8"	34 1/16"	48"	31 3/4"	14 1/16"	14 7/8"	Yes	Yes

Product Details – Jive Tables

T-Leg Extruded (Column) – Flip Base (Rectangle Top)

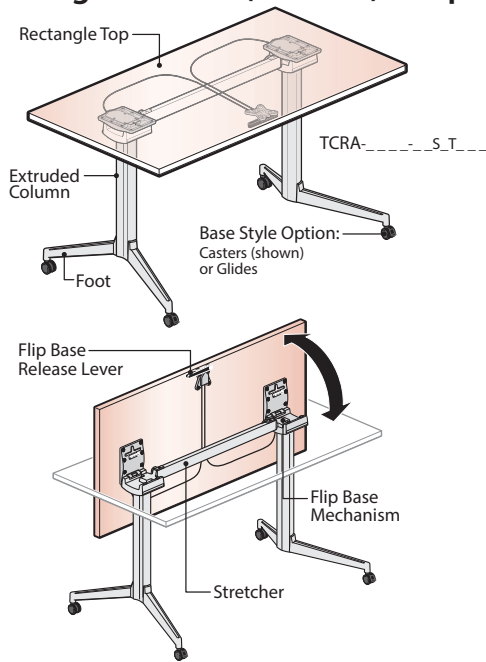

Wood Grain Direction

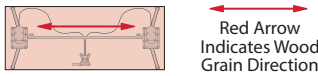

Top Cutout Options

- Power and Data access may be provided by specifying optional factory installed cutouts.
- Cutouts are designed to accommodate separately specified Flip Top Units.

N No Cutout

A Center Power Cutout for 4-Port Single Sided Flip Top Unit



Center Power Cutout Location

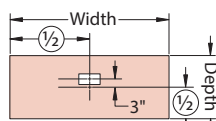

EUE1 Flip Top Unit Single Sided/2 Port

F Center Power Cutout for 4-Port Single Sided Flip Top Unit



EUE1 Flip Top Unit Single Sided/4 Port

J Center Power Cutout for 6-Port Single Sided Flip Top Unit



EUE1 Flip Top Unit Single Sided/6 Port

Base & Wire Management Options

Base - No Power

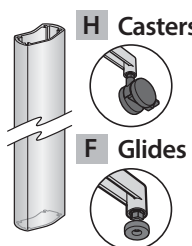

Base - Power Ready

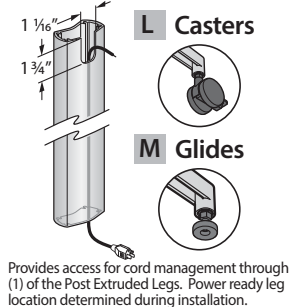

Table Heights

29" High Tables

- Seated applications.
- Specify with standard height seating (17"-18" seat heights).



Component Materials/Finishes

COMPONENT NAME		MATERIALS/ FINISHES
Rectangle Top	Edge option (Knife or Edgeband) is applied to all edges.	(L) Laminate – Specify separate top and edge finish colors. (J) Edgeband (F) Knife
		(W) Wood – Specify a single finish color for top and edge. (K) Edgeband (U) Knife
T-Leg Extruded Base	Feet, Extruded Columns, and Stretcher	(A) Painted – The Foot, Column and Flip Base Mechanism and Stretcher are painted metal, specify base trim color. (B) Polished – The Foot is polished aluminum. The Column, Flip Base Mechanism and Stretcher are painted metal, specify base trim color.
	Flip Base Mechanism	Painted Metal – Standard in black.
	Casters	Standard in black.

Sizes and Dimensions

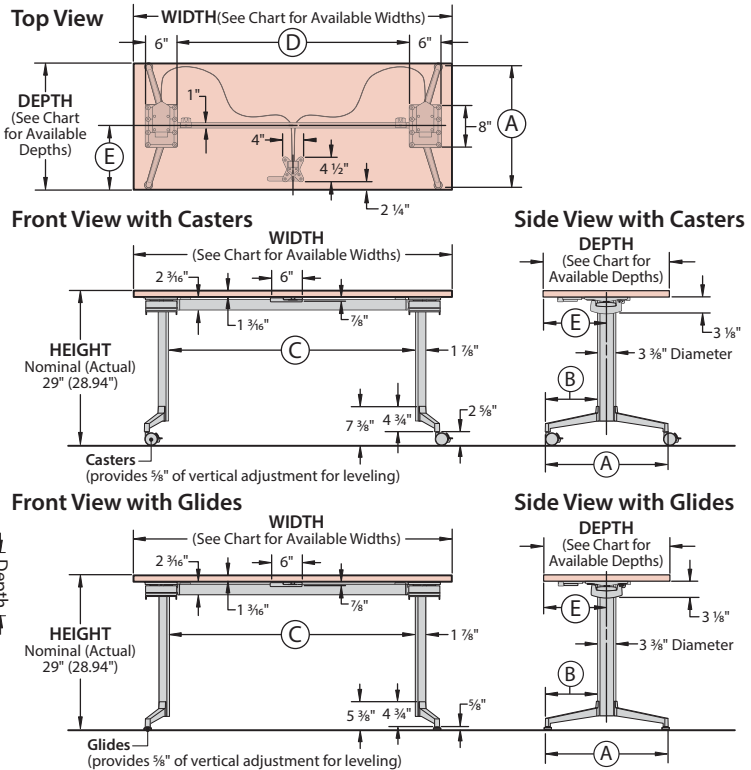

Nesting Flip Tables

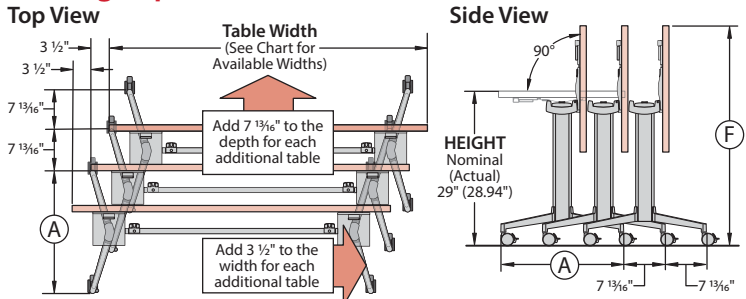

HEIGHT Nominal (Actual)	DEPTH Nominal (Actual)	WIDTH Nominal (Actual)	Component Dimensions						Caster/Glide Availability	
			A	B	C	D	E	F	Casters	Glides
29" (28.94")	18" (17.68")	48" (47.68")	17 3/8"	7 1/8"	32 1/4"	28"	8 13/16"	38 1/2"	Yes	Yes
		60" (59.68")	17 3/8"	7 1/8"	44 1/4"	40"	8 13/16"	38 1/2"	Yes	Yes
		72" (71.68")	17 3/8"	7 1/8"	56 1/4"	52"	8 13/16"	38 1/2"	Yes	Yes
	24" (23.68")	48" (47.68")	23 3/8"	9 7/8"	32 1/4"	28"	11 13/16"	41 1/2"	Yes	Yes
		60" (59.68")	23 3/8"	9 7/8"	44 1/4"	40"	11 13/16"	41 1/2"	Yes	Yes
		72" (71.68")	23 3/8"	9 7/8"	56 1/4"	52"	11 13/16"	41 1/2"	Yes	Yes
30" (29.68")	48" (47.68")	28 13/16"	12 3/4"	32 1/4"	28"	14 13/16"	44 1/2"	Yes	Yes	
	60" (59.68")	28 13/16"	12 3/4"	44 1/4"	40"	14 13/16"	44 1/2"	Yes	Yes	
	72" (71.68")	28 13/16"	12 3/4"	56 1/4"	52"	14 13/16"	44 1/2"	Yes	Yes	
36" (35.68")	60" (59.68")	31 7/8"	14 3/4"	44 1/4"	40"	17 13/16"	47 1/2"	Yes	Yes	
	72" (71.68")	31 7/8"	14 3/4"	56 1/4"	52"	17 13/16"	47 1/2"	Yes	Yes	

Product Details – Jive Tables

Product Details | Jive Tables – T-Leg – Round (Column) – Flip Base (Rectangle Top)

T-Leg Round (Column) – Flip Base (Rectangle Top)

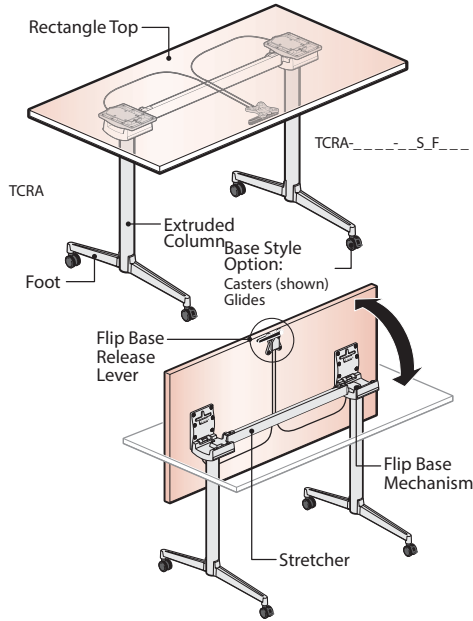

Wood Grain Direction

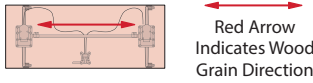

Top Cutout Options

- Power and Data access may be provided by specifying optional factory installed cutouts.
- Cutouts are designed to accommodate separately specified Flip Top Units.

N No Cutout

A Center Power
Cutout for 4-Port Single Sided Flip Top Unit



F Center Power
Cutout for 4-Port Single Sided Flip Top Unit



J Center Power
Cutout for 6-Port Single Sided Flip Top Unit

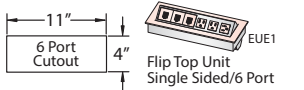

Base & Wire Management Options

Base - No Power

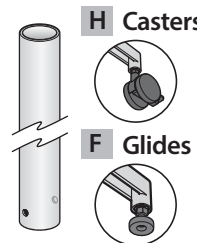

Does not provide access for cord management.

Base - Power Ready

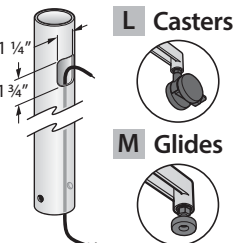

Provides access for cord management through (1) of the Round Column. Power ready leg location determined during installation.

Table Heights

29" High Tables

- Seated applications.
- Specify with standard height seating (17"-18" seat heights).



Component Materials/Finishes

COMPONENT NAME		MATERIALS/ FINISHES	
Rectangle Top	Edge option (Knife or Edgeband) is applied to all edges.	(L) Laminate – Specify separate top and edge finish colors.	(J) Edgeband
		(W) Wood – Specify a single finish color for top and edge.	(F) Knife
			(K) Edgeband
T-Leg Round Base	Feet, Round Columns, Flip Base Mechanism and Stretcher	(A) Painted – The Foot, Column and Flip Base Mechanism and Stretcher are painted metal, specify base trim color.	(U) Knife
		(B) Polished – The Foot is polished aluminum. The Column, Flip Base Mechanism and Stretcher are painted metal, specify base trim color.	
	Casters	Standard in black.	

Sizes and Dimensions

Top View

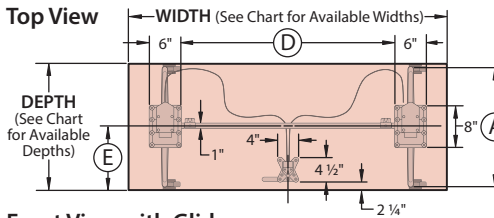

Front View with Glides

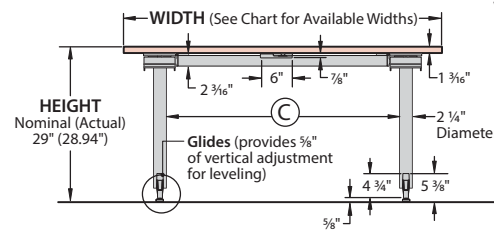

Side View

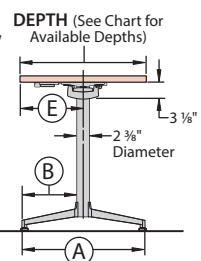

Front View with Casters

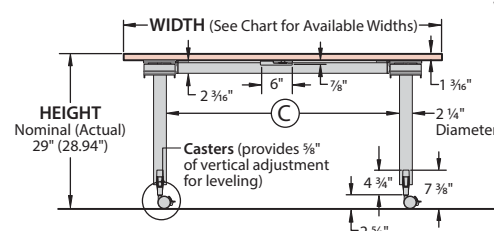

Side View

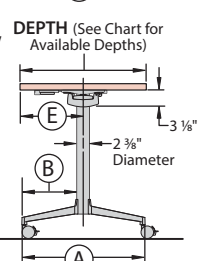

Nesting Flip Tables

Top View

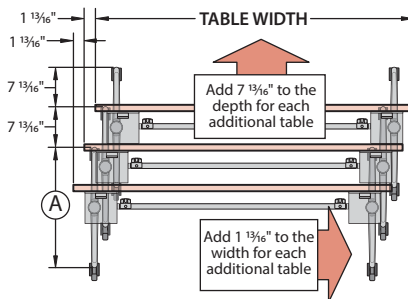

Side View

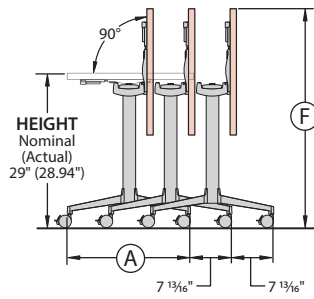

HEIGHT Nominal (Actual)	DEPTH Nominal (Actual)	WIDTH Nominal (Actual)	Component Dimensions						Caster/Glide Availability	
			(A)	(B)	(C)	(D)	(E)	(F)	Casters	Glides
29" (28.94")	18" (17.68")	48" (47.68")	16 7/8"	7 1/4"	31 3/4"	28"	8 13/16"	38 1/2"	Yes	Yes
		60" (59.68")	16 7/8"	7 1/4"	43 3/4"	40"	8 13/16"	38 1/2"	Yes	Yes
		72" (71.68")	16 7/8"	7 1/4"	55 3/4"	52"	8 13/16"	38 1/2"	Yes	Yes
29" (28.94")	24" (23.68")	48" (47.68")	22 7/8"	10 1/4"	31 3/4"	28"	11 13/16"	41 1/2"	Yes	Yes
		60" (59.68")	22 7/8"	10 1/4"	43 3/4"	40"	11 13/16"	41 1/2"	Yes	Yes
		72" (71.68")	22 7/8"	10 1/4"	55 3/4"	52"	11 13/16"	41 1/2"	Yes	Yes
29" (28.94")	30" (29.68")	48" (47.68")	28 7/8"	13 1/4"	31 3/4"	28"	14 13/16"	44 1/2"	Yes	Yes
		60" (59.68")	28 7/8"	13 1/4"	43 3/4"	40"	14 13/16"	44 1/2"	Yes	Yes
		72" (71.68")	28 7/8"	13 1/4"	55 3/4"	52"	14 13/16"	44 1/2"	Yes	Yes
29" (28.94")	36" (35.68")	60" (59.68")	31 7/8"	14 3/4"	43 3/4"	40"	17 13/16"	47 1/2"	Yes	Yes
		72" (71.68")	31 7/8"	14 3/4"	55 3/4"	52"	17 13/16"	47 1/2"	Yes	Yes

Product Details – Jive Tables

Swivel Base – Square (Top)

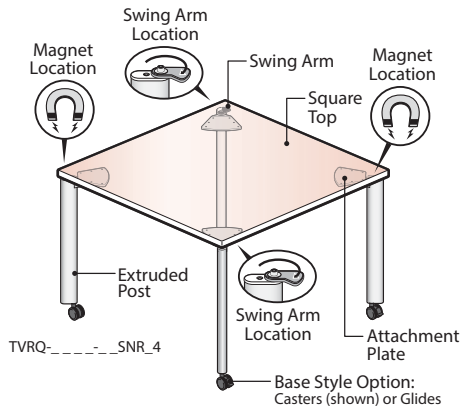

Wood Grain Direction

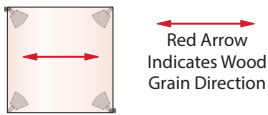

Base Style Options

Swivel Base (No Power)

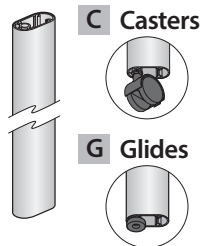

Does not provide access for cord management through the leg.

MagneLine™ Swivel Magnetic Ganging Mechanism

- Each Swivel Base table includes an integrated Magnetic ganging mechanism to easily connects tables together.
- Swing Arms swivel out to attach to magnet locations on adjacent Swivel Base Tables.

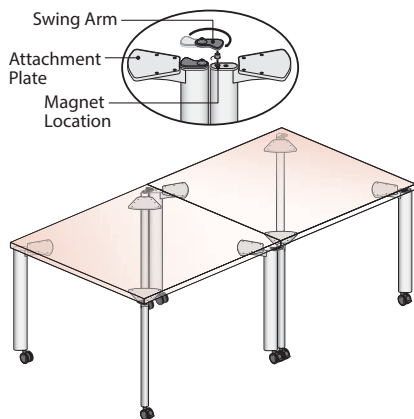

Component Materials/Finishes

COMPONENT NAME		MATERIALS/ FINISHES
Square Top	(L) Laminate – Specify separate top and edge finish colors.	(J) Laminate Edgeband
	(W) Wood – Specify a single finish color for top and edge.	(K) Wood Edgeband
Post Extruded Base	Extruded Post and Attachment Plates	Painted Metal – Specify Base Trim Color
	Swing Arm	Plastic - Standard in red.
	Base Styles	Casters – Standard in black. Glides – Standard in black.

Sizes and Dimensions

Top View

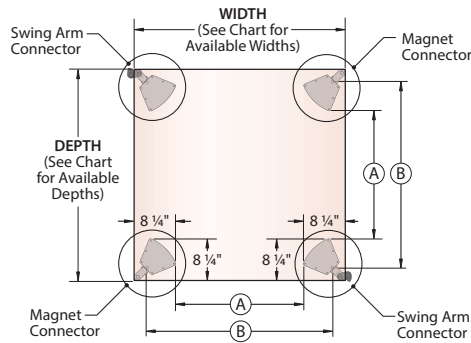

Front View with Glides

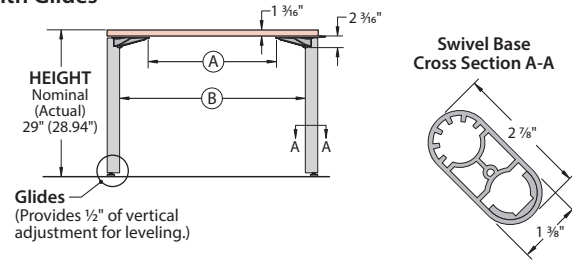

Front View with Casters

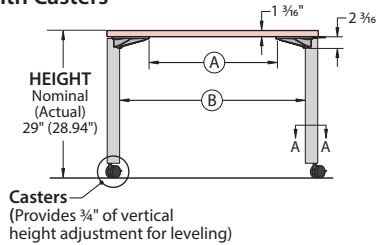

HEIGHT Nominal (Actual)	DEPTH Nominal (Actual)	WIDTH Nominal (Actual)	(A)	(B)
29" (28.94")	24" (23.68")	24" (23.68")	7 1/4"	18 1/16"
	30" (29.68")	30" (29.68")	13 1/4"	24 1/16"
	36" (35.68")	36" (35.68")	19 1/4"	30 1/16"
	42" (41.68")	42" (41.68")	25 1/4"	36 1/16"
	48" (47.68")	48" (47.68")	31 1/4"	42 1/16"

Table Heights

29" High Tables

- Seated applications.
- Specify with standard height seating (17"-18" seat heights).

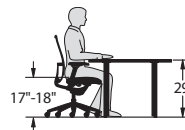

Product Details – Jive Tables

Swivel Base – Square (Top)

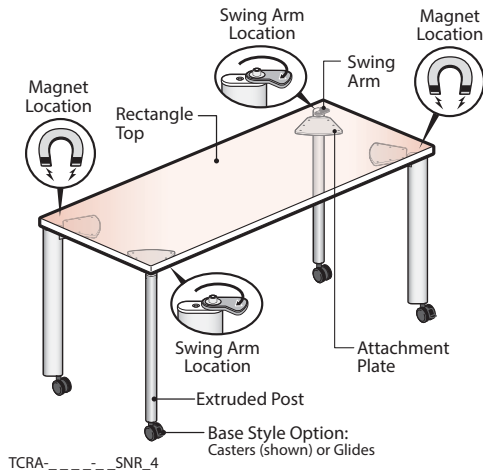

Wood Grain Direction

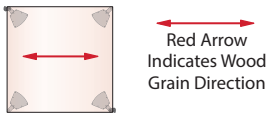

Base Style Options

Swivel Base (No Power)

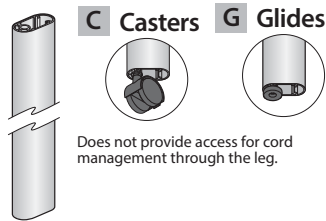

MagneLine™ Swivel Magnetic Ganging Mechanism

- Each Swivel Base table includes an integrated Magnetic ganging mechanism to easily connect tables together.
- Swing Arms swivel out to attach to magnet locations on adjacent Swivel Base Tables.

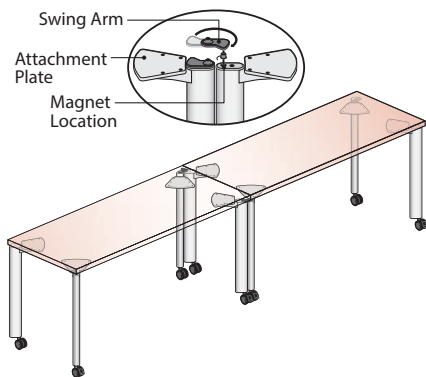
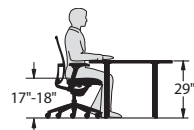

Table Heights

29" High Tables

- Seated applications.
- Specify with standard height seating (17"-18" seat heights).



Component Materials/Finishes

COMPONENT NAME	MATERIALS/ FINISHES	
Rectangle Top Edge Option is applied to all edges.	(L) Laminate – Specify separate top and edge finish colors.	(J) Laminate Edgeband
	(W) Wood – Specify a single finish color for top and edge.	(K) Wood Edgeband
Post Extruded Base	Extruded Post and Attachment Plates	Painted Metal – Specify Base Trim Color
	Swing Arm	Plastic – Standard in red.
	Base Styles	Casters – Standard in black. Glides – Standard in black.

Sizes and Dimensions

Top View

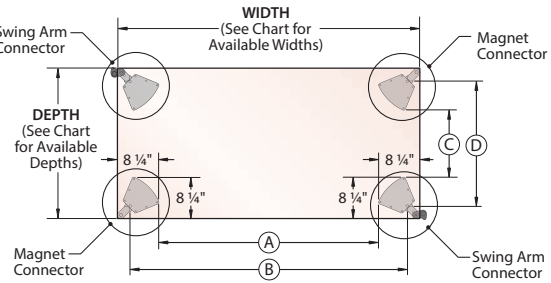

Front View with Glides

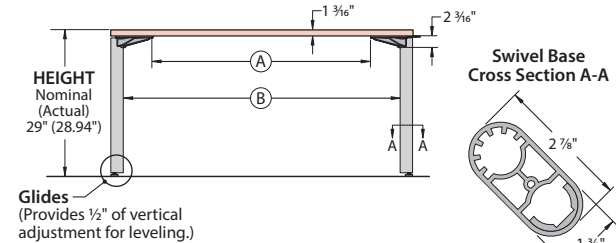

Front View with Casters

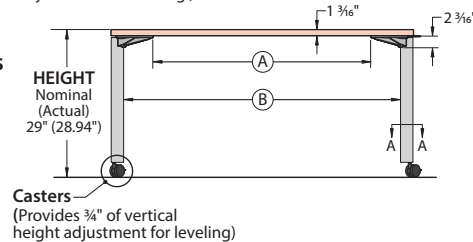

HEIGHT Nominal (Actual)	DEPTH Nominal (Actual)	WIDTH Nominal (Actual)	Component Dimensions			
			(A)	(B)	(C)	(D)
29" (28.94")	18" (17.68")	48" (47.68")	31 1/4"	42 1/16"	1 1/4"	12 1/16"
		54" (53.68")	37 1/4"	48 1/16"	1 1/4"	12 1/16"
		60" (59.68")	43 1/4"	54 1/16"	1 1/4"	12 1/16"
		66" (65.68")	49 1/4"	60 1/16"	1 1/4"	12 1/16"
		72" (71.68")	55 1/4"	66 1/16"	1 1/4"	12 1/16"
29" (28.94")	24" (23.68")	36" (35.68")	19 1/4"	30 1/16"	7 1/4"	18 1/16"
		42" (41.68")	25 1/4"	36 1/16"	7 1/4"	18 1/16"
		48" (47.68")	31 1/4"	42 1/16"	7 1/4"	18 1/16"
		54" (53.68")	37 1/4"	48 1/16"	7 1/4"	18 1/16"
		60" (59.68")	43 1/4"	54 1/16"	7 1/4"	18 1/16"
		66" (65.68")	49 1/4"	60 1/16"	7 1/4"	18 1/16"
29" (28.94")	30" (29.68")	36" (35.68")	19 1/4"	30 1/16"	13 1/4"	24 1/16"
		42" (41.68")	25 1/4"	36 1/16"	13 1/4"	24 1/16"
		48" (47.68")	31 1/4"	42 1/16"	13 1/4"	24 1/16"
		54" (53.68")	37 1/4"	48 1/16"	13 1/4"	24 1/16"
		60" (59.68")	43 1/4"	54 1/16"	13 1/4"	24 1/16"
		66" (65.68")	49 1/4"	60 1/16"	13 1/4"	24 1/16"
29" (28.94")	36" (35.68")	66" (65.68")	49 1/4"	60 1/16"	19 1/4"	30 1/16"
		72" (71.68")	55 1/4"	66 1/16"	19 1/4"	30 1/16"

Product Details – Jive Tables

Swivel Base – Trapezoid (Top)

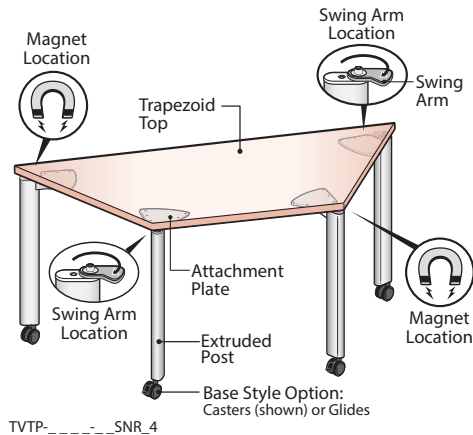

Wood Grain Direction

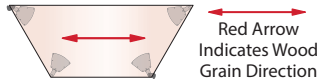

Base Style Options

Swivel Base (No Power)

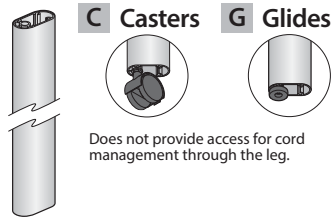

MagneLine™ Swivel Magnetic Ganging Mechanism

- Each Swivel Base table includes an integrated Magnetic ganging mechanism to easily connect tables together.
- Swing Arms swivel out to attach to magnet locations on adjacent Swivel Base Tables.

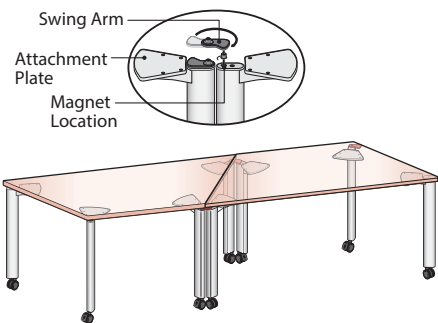

Table Heights

29" High Tables

- Seated applications.
- Specify with standard height seating (17"-18" seat heights).



Component Materials/Finishes

COMPONENT NAME	MATERIALS/ FINISHES	
Trapezoid Top Edge Option is applied to all edges.	(L) Laminate – Specify separate top and edge finish colors.	(J) Laminate Edgeband
	(W) Wood – Specify a single finish color for top and edge.	(K) Wood Edgeband
Post Extruded Base	Extruded Post and Attachment Plates	Painted Metal – Specify Base Trim Color
	Swing Arm	Plastic – Standard in red.
	Base Styles	Casters – Standard in black. Glides – Standard in black.

Sizes and Dimensions

Top View

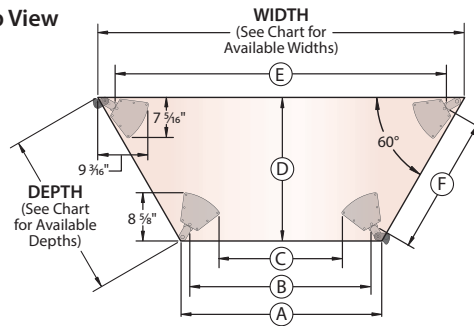

Front View with Glides

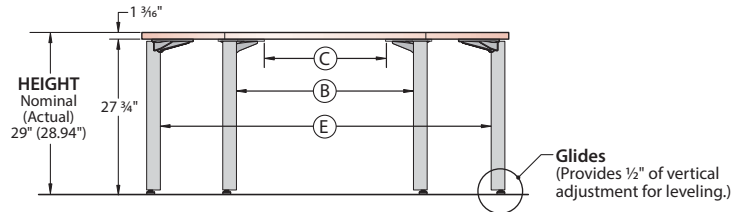

Front View with Casters

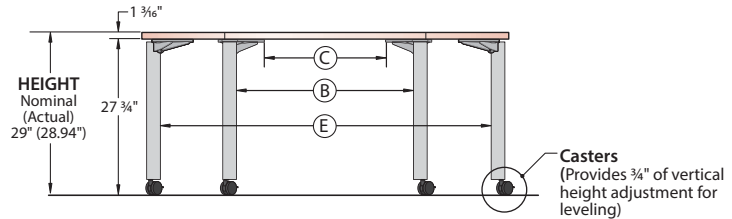

HEIGHT Nominal (Actual)	DEPTH Nominal (Actual)	WIDTH Nominal (Actual)	Component Dimensions					
			A	B	C	D	E	F
29" (28.94")	24" (23.68")	48" (47.68")	24"	20 1/4"	9 15/16"	20 1/2"	41 1/8"	21 1/4"
		54" (53.68")	30"	26 1/4"	15 15/16"	20 1/2"	47 1/8"	21 1/4"
		60" (59.68")	36"	32 1/4"	21 15/16"	20 1/2"	53 1/8"	21 1/4"
		66" (65.68")	42"	38 1/4"	27 15/16"	20 1/2"	59 1/8"	21 1/4"
30" (29.68")	60" (59.68")	72" (71.68")	48"	44 1/4"	33 15/16"	20 1/2"	65 1/8"	21 1/4"
		60" (59.68")	30"	26 1/4"	15 15/16"	25 11/16"	53 1/8"	27 1/4"
		66" (65.68")	36"	32 1/4"	21 15/16"	25 11/16"	59 1/8"	27 1/4"
		72" (71.68")	42"	38 1/4"	27 15/16"	25 11/16"	65 1/8"	27 1/4"

Product Details – Jive Tables

Swivel Base – Crescent (Top)

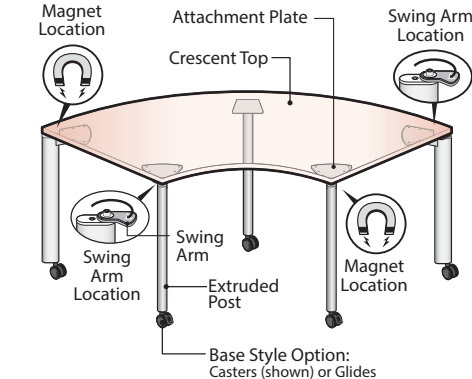

Wood Grain Direction

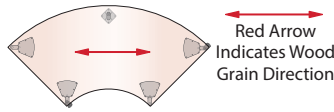

Base Style Options

Swivel Base (No Power)

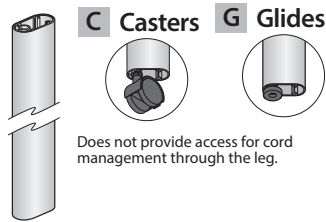

MagneLine™ Swivel Magnetic Ganging Mechanism

- Each Swivel Base table includes an integrated Magnetic ganging mechanism to easily connect tables together.
- Swing Arms swivel out to attach to magnet locations on adjacent Swivel Base Tables.

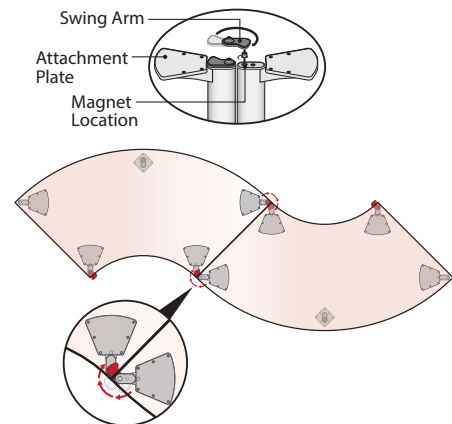

Component Materials/Finishes

COMPONENT NAME		MATERIALS/ FINISHES
Crescent Top	Edge Option is applied to all edges.	(L) Laminate – Specify separate top and edge finish colors. (J) Laminate Edgeband (W) Wood – Specify a single finish color for top and edge. (K) Wood Edgeband
Post Extruded Base	Extruded Post and Attachment Plates	Painted Metal – Specify Base Trim Color
	Swing Arm	???
	Base Styles	Casters – Standard in black. Glides – Standard in black.

Sizes and Dimensions

Top View

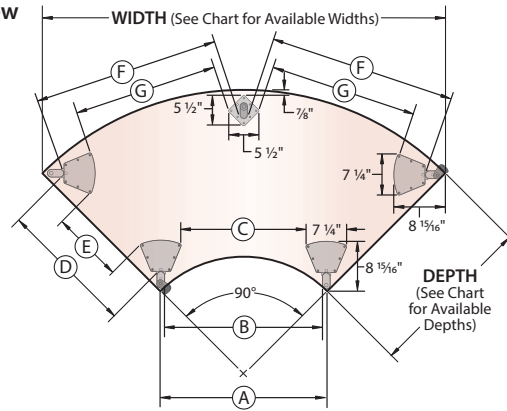

Front View with Glides

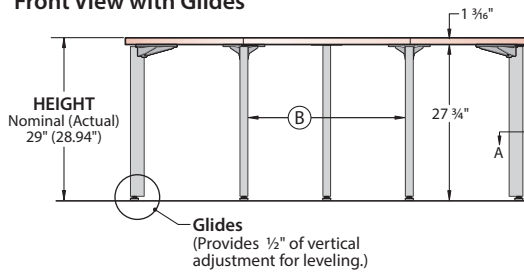

Swivel Base Cross Section A-A

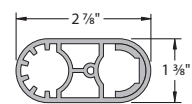

Front View with Casters

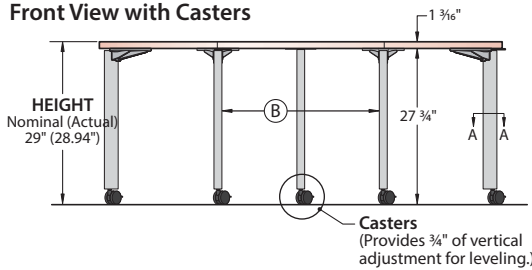

HEIGHT Nominal (Actual)	DEPTH Nominal (Actual)	WIDTH Nominal (Actual)	Component Dimensions						
			A	B	C	D	E	F	G
24" (23.68")	24" (23.68")	60" (59.68")	26 3/16"	24 13/16"	18 15/16"	18 11/16"	7 1/4"	27 1/16"	19 9/16"
29" (28.94")	30" (29.68")	72" (71.68")	29 11/16"	28 3/16"	27 3/4"	24 11/16"	13 1/4"	33 1/2"	26 1/16"
	36" (35.68")	84" (83.68")	33 3/16"	31 13/16"	34 1/4"	30 11/16"	19 1/4"	27 1/16"	32 1/2"

Table Heights

29" High Tables

- Seated applications.
- Specify with standard height seating (17"-18" seat heights).

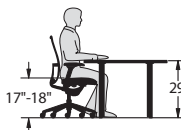

Product Details – Jive Tables

Swivel Base – Corner, Transitional Extended (Top)

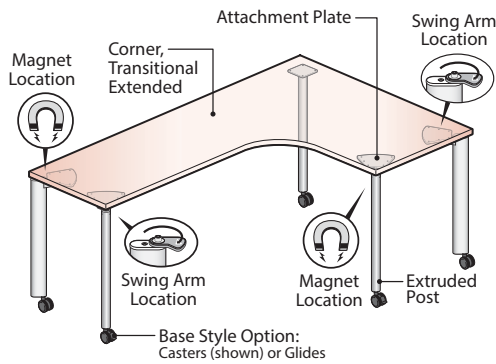

TVCX-_-_-_-SNR-_-

Wood Grain Direction and Handedness

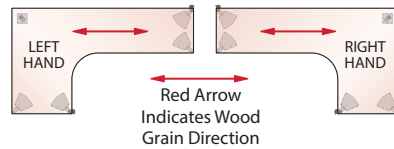

Base Style Options

Swivel Base (No Power)

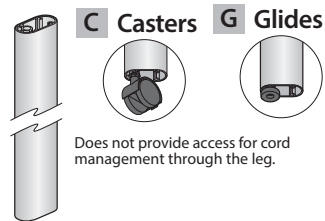

MagneLine™ Swivel Magnetic Ganging Mechanism

- Each Swivel Base table includes an integrated Magnetic ganging mechanism to easily connect tables together.
- Swing Arms swivel out to attach to magnet locations on adjacent Swivel Base Tables.

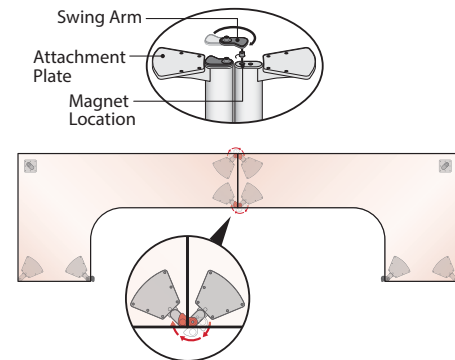
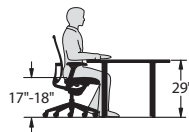

Table Heights

29" High Tables

- Seated applications.
- Specify with standard height seating (17"-18" seat heights).



Component Materials/Finishes

COMPONENT NAME		MATERIALS/ FINISHES
Corner, Transitional Extended Top	Edge Option is applied to all edges.	(L) Laminate – Specify separate top and edge finish colors.
		(J) Laminate Edgeband
Post Extruded Base	Extruded Post and Attachment Plates	(W) Wood – Specify a single finish color for top and edge.
	Swing Arm	(K) Wood Edgeband
	Base Styles	Painted Metal – Specify Base Trim Color
		Plastic - Standard in red.
		Casters – Standard in black.
		Glides – Standard in black.

Sizes and Dimensions

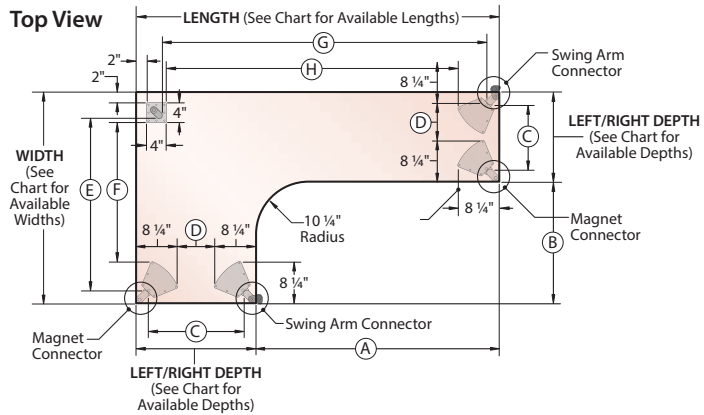

Front View with Glides

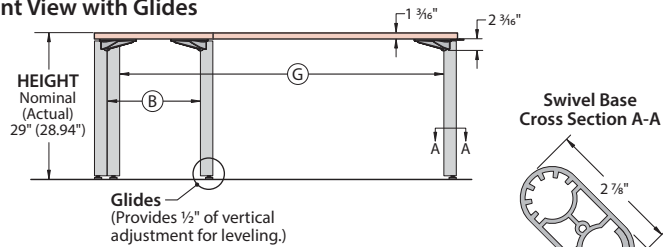

Front View with Casters

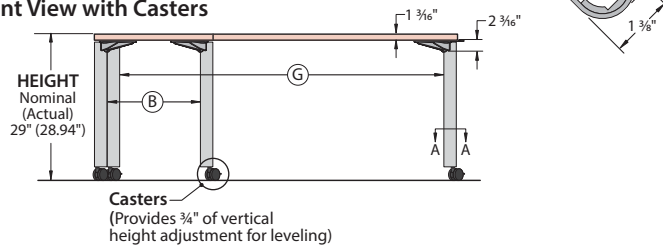

HEIGHT Nominal (Actual)	LEFT/RIGHT DEPTH Nominal (Actual)	WIDTH Nominal (Actual)	LENGTH Nominal (Actual)	Component Dimensions							
				A	B	C	D	E	F	G	H
29" (28.94")	18" (17.68")/ 24" (23.68")	42" (41.68")	60" (59.68")	36"	18"	18 1/16"	7 1/4"	34"	27 7/16"	52"	45 1/16"
			72" (71.68")	48"	18"	18 1/16"	7 1/4"	34"	27 7/16"	64"	57 1/16"
	24" (23.68")/ 18" (17.68")	42" (41.68")	60" (59.68")	36"	24"	18 1/16"	7 1/4"	40"	33 7/16"	52"	45 1/16"
			72" (71.68")	48"	24"	18 1/16"	7 1/4"	40"	33 7/16"	64"	57 1/16"
	24" (23.68")/ 30" (29.68")	48" (47.68")	60" (59.68")	30"	24"	24 1/16"	13 1/4"	34"	27 7/16"	52"	45 1/16"
			72" (71.68")	42"	24"	24 1/16"	13 1/4"	34"	27 7/16"	64"	57 1/16"
	30" (29.68")/ 24" (23.68")	48" (47.68")	60" (59.68")	30"	30"	24 1/16"	13 1/4"	40"	33 7/16"	52"	45 1/16"
			72" (71.68")	42"	30"	24 1/16"	13 1/4"	40"	33 7/16"	64"	57 1/16"

Product Details – Jive Tables

Swivel Base – Corner, Extended (Top)

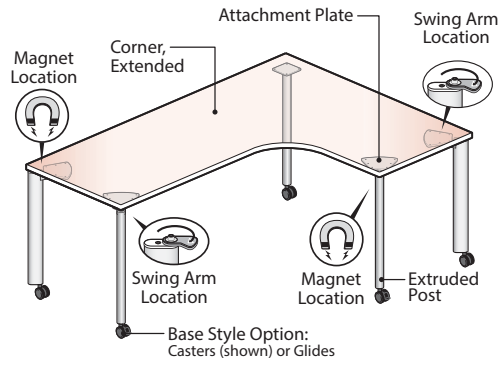

TVCE-----SNR---

Wood Grain Direction and Handedness

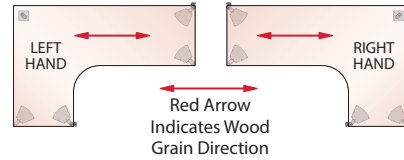

Base Style Options

Swivel Base (No Power)

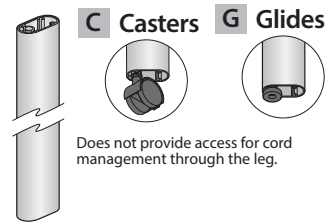

MagneLine™ Swivel Magnetic Ganging Mechanism

- Each Swivel Base table includes an integrated Magnetic ganging mechanism to easily connect tables together.
- Swing Arms swivel out to attach to magnet locations on adjacent Swivel Base Tables.

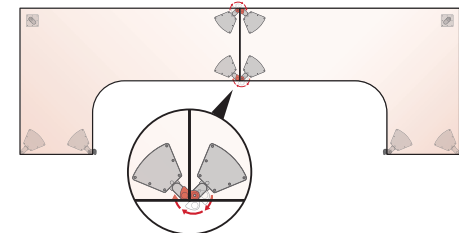
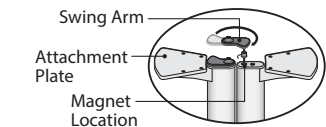
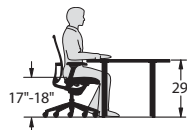

Table Heights

29" High Tables

- Seated applications.
- Specify with standard height seating (17"-18" seat heights).



Component Materials/Finishes

COMPONENT NAME		MATERIALS/ FINISHES
Corner, Transitional Extended Top	Edge Option is applied to all edges.	(L) Laminate – Specify separate top and edge finish colors. (J) Laminate Edgeband (W) Wood – Specify a single finish color for top and edge. (K) Wood Edgeband
Post Extruded Base	Extruded Post and Attachment Plates	Painted Metal – Specify Base Trim Color
	Swing Arm	Plastic - Standard in red.
	Base Styles	Casters – Standard in black. Glides – Standard in black.

Sizes and Dimensions

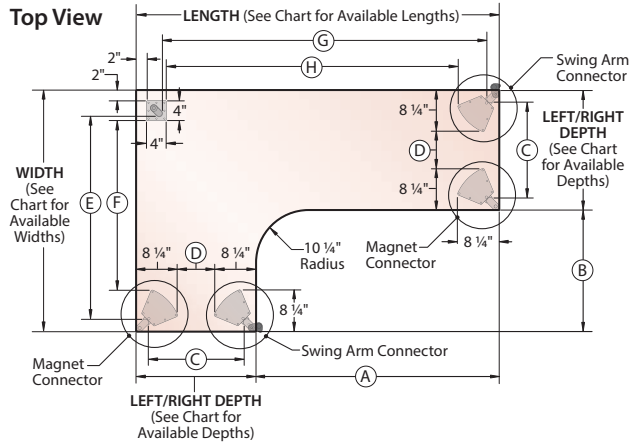

Front View with Glides

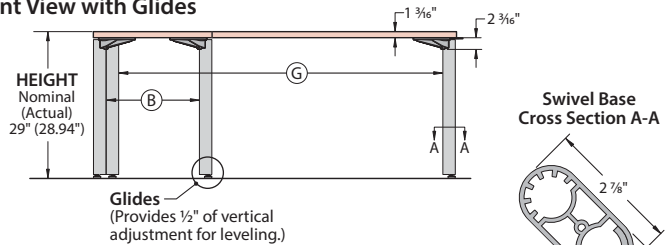

Front View with Casters

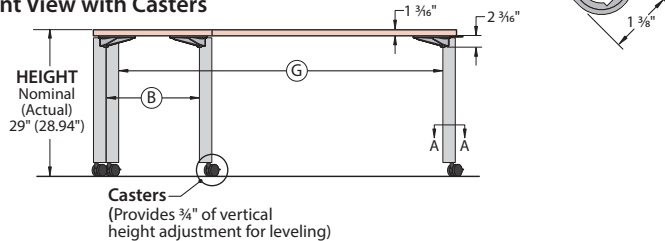

HEIGHT Nominal (Actual)	LEFT/RIGHT DEPTH Nominal (Actual)	WIDTH Nominal (Actual)	LENGTH Nominal (Actual)	Component Dimensions							
				A	B	C	D	E	F	G	H
29" (28.94")	24" (23.68")/ 24" (23.68")	42" (41.68")	60" (59.68")	36"	18"	18 1/16"	7 1/4"	34"	27 7/16"	52"	45 7/16"
			72" (71.68")	48"	18"	18 1/16"	7 1/4"	34"	27 7/16"	64"	57 7/16"
	24" (23.68")/ 24" (23.68")	48" (47.68")	60" (59.68")	36"	24"	18 1/16"	7 1/4"	40"	33 7/16"	52"	45 7/16"
			72" (71.68")	48"	24"	18 1/16"	7 1/4"	40"	33 7/16"	64"	57 7/16"
	30" (29.68")/ 30" (29.68")	42" (41.68")	60" (59.68")	30"	24"	24 1/16"	13 1/4"	34"	27 7/16"	52"	45 7/16"
			72" (71.68")	42"	24"	24 1/16"	13 1/4"	34"	27 7/16"	64"	57 7/16"
	30" (29.68")/ 30" (29.68")	48" (47.68")	60" (59.68")	30"	30"	24 1/16"	13 1/4"	40"	33 7/16"	52"	45 7/16"
			72" (71.68")	42"	30"	24 1/16"	13 1/4"	40"	33 7/16"	64"	57 7/16"

Specification Guide – Planes Tables

Product Details Section

Product Details – Planes Collaborative Tables

Planes Tables Introduction

Planes is a compelling table and ancillary product line that supports a wide variety of spaces with easy and effortless functionality. From conference rooms to individual workstations, Planes enables visual consistency throughout any work environment with its application breadth, top shapes, size range, and base choices. In addition, Planes is part of Haworth's Integrated Palette, which provides a holistic design and finish offering for effective solutions.

The Planes Collection is more than just tables, Planes offers:

- Collaborative Tables: Y-Leg, X-Base, and Disc Base
- Training Tables: C-Leg
- Conference Tables: Interior Leg, Perimeter Leg, and Column Base
- Carts
- Credenzas
- Height Adjustable Tables: Freestanding and Bench (See Height Adjustable Tables Price Book)
- Easels, Information Boards, Horizontal Wall Rail System (See Accessories Price List)

Planes allows easy functionality with the ability to flip, store, conceal, connect, adjust, and plug in effortlessly:

- Flip – Reconfigure spaces with the flip top option
- Store – Save valuable floor space with the nesting feature
- Conceal – Cleanly manage wires and cables
- Connect – Gang tables together effortlessly
- Adjust – Raise and lower worksurfaces with manual or electrical height adjustment mechanisms
- Plug In – Power tables individually or distribute between

Global Design:

Planes offers a clean, simple, crisp aesthetic; designed in conjunction with Haworth Design Studio and Daniel Figueroa of Bad Munder, Germany. Planes is truly a global product line.

Sustainability:

Planes is BIFMA level® 3, GREENGUARD certified, contributes LEED points, and includes FSC wood.

Product Details – Planes Collaborative Tables

Y-Leg Collaborative Tables – Overview

Collaborative tables are ideal for a room whose purpose is constantly changing. The tables can be reconfigured for multiple uses ranging from conferencing to collaborative to dining and everything in between. The base is available with optional casters for easy mobility. The tops, up to 72" wide, also have the option to flip for optimum mobility and storage. The possibilities are endless with the collaborative table offering.

Features:

• Flip Top and Non-Flip Top Tables

- Y-Leg Tables are available with a flip top that allows the tables to nest together for easy storage.
- To flip the table top to the 90° position, pull the left and right side finger pulls that release locks to allow pneumatic assisted flip action.
- To return top to horizontal position, pull down on table top edge and top locks back into horizontal position.

• Cable Management

- The Stretcher runs between the two Y-legs in the base of the collaborative tables provides lay-in cable management.
- The Stretcher includes a grommet, approximately 2 ½" in diameter, in one side to allow access to an outside power source.
- Wires can be routed vertically using the separately specified Y-Leg Vertical Wire Manager.

• Base Options:

- The Y-Leg Base is painted aluminum and may be specified with Casters or Glides.

• Caster and Glide Options:

- Optional casters or glides are field interchangeable. (heights are the same).
- Caster option includes (2) locking and (2) non-locking casters.
- Casters have light platinum hub with graphite tread
- Glides are light platinum.
- Glides provide 1/2" of vertical adjustment for leveling.

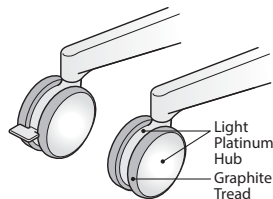

Casters
(includes 2 locking and 2 non-locking)

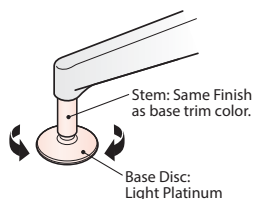

Glides
(Provides ½" of vertical adjustment for leveling)

Wood Grain Direction



Rectangular



Pebble



Hexagon



Polygon



Half Round

Y-Leg Table (shown in horizontal position)

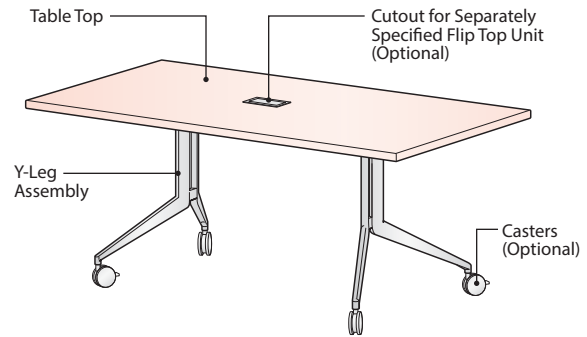

Y-Leg Flip Top Table (shown in 90° position)

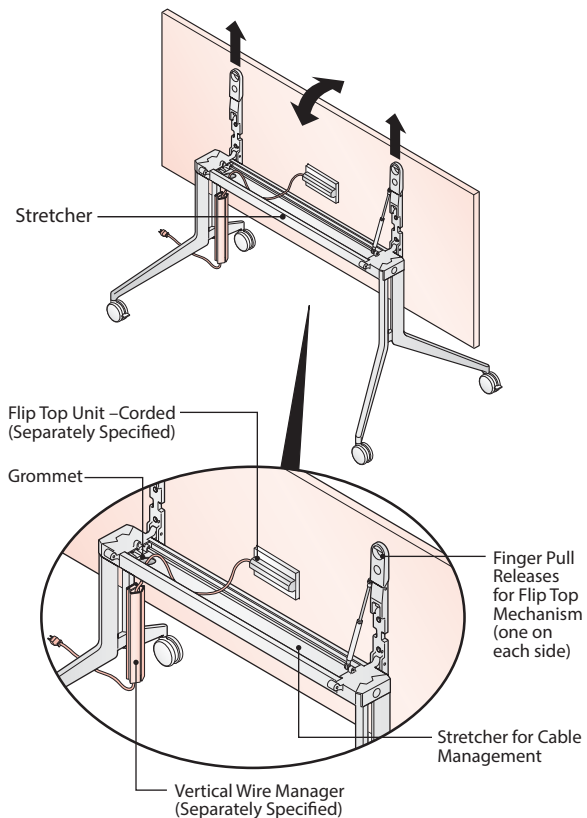

Product Details – Planes Collaborative Tables

Y-Leg Table – Rectangular Flip Top or Non-Flip Top

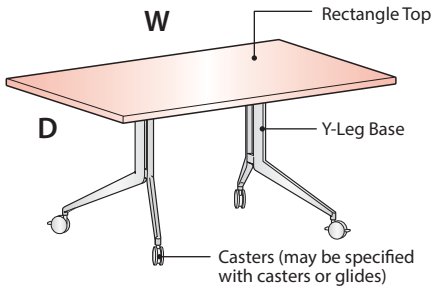

Non-Flip Top Table Sizes

		Width						
		60"	66"	72"	78"	84"	90"	96"
Depth	30"	●	●	●	N/A	N/A	N/A	N/A
	36"	●	●	●	●	●	●	●

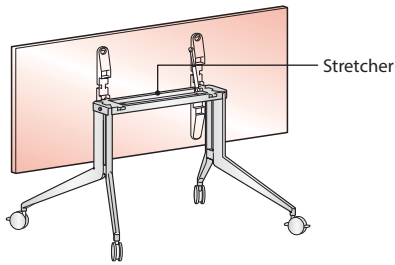

Flip Top Table Sizes

		Width		
		60"	66"	72"
Depth	30"	●	●	●
	36"	●	●	●

Edge Options for Laminate Tops

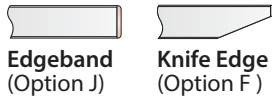

Edge Options for Wood Tops

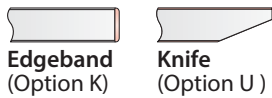

Component Materials/Finishes

COMPONENT NAME	MATERIALS/FINISHES	
Rectangle Top • Flip Top or Non-Flip Top • (S) Standard core only • Cutouts for Flip Top Units: (N) None (F) 4 Ports - Centered (J) 6 Ports - Centered	Laminate Top – Specify surface color and separate edge finish color	(J) 3mm Edgeband (F) Knife Edge
	Wood Top – Specify surface and edge finish color	(K) Wood Edgeband (U) Wood Knife Edge
Y-Leg Base and Stretcher	Painted Aluminum – Specify Base/Stretcher Trim Color	
Casters (Optional)	Casters are light platinum hub with graphite tread	
Glides (Optional)	Glides are light platinum, Stem is same finish as base trim color.	

Dimensions

Top View

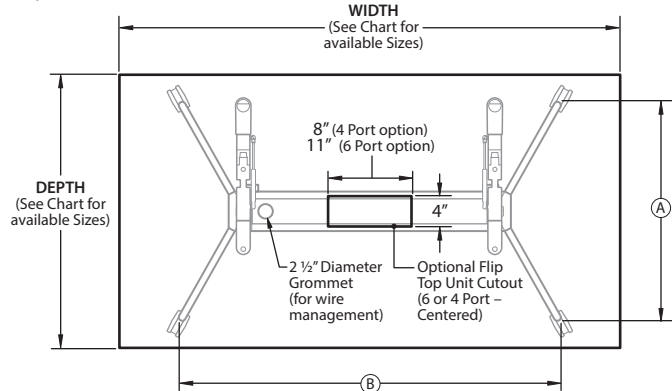

Front View

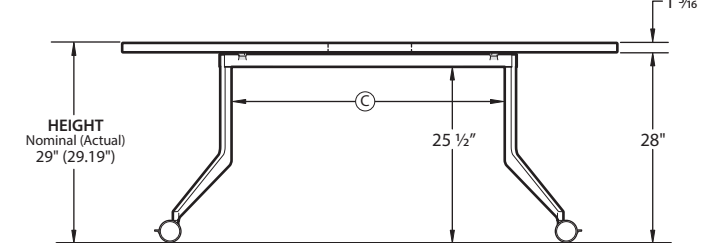

Note • Optional Glides provide a 1/2" of adjustment for vertical leveling.
 • A panel mounted worksurface and an adjacent freestanding table do not have the same level of adjustment to horizontally align worktops. Building floors with inherently uneven characteristics may also contribute this planning condition; plan accordingly.

Dimensions

TABLETOP		Y-LEG BASE		
Depth Nominal (Actual)	Width Nominal (Actual)	(A)	(B)	(C)
30" (29.68")	60" (59.68")	22 1/4"	45 7/8"	32 3/16"
	66" (65.68")	22 1/4"	47 7/8"	34 3/16"
	72" (71.68")	22 1/4"	53 7/8"	40 3/16"
36" (35.68")	60" (59.68")	28 1/2"	49 1/2"	32 3/16"
	66" (65.68")	28 1/2"	51 1/2"	34 3/16"
	72" (71.68")	28 1/2"	57 1/2"	40 3/16"
	78" (77.68")*	28 1/2"*	63 1/2"*	46 3/16"*
	84" (83.68")*	28 1/2"*	69 1/2"*	52 3/16"*
	90" (89.68")*	28 1/2"*	75 1/2"*	58 3/16"*
96" (95.68")*	28 1/2"*	77 1/2"*	60 3/16"*	

* Sizes only available with Non-Flip Table Tops

Product Details – Planes Collaborative Tables

Y-Leg Table – Pebble Flip Top or Non-Flip Top

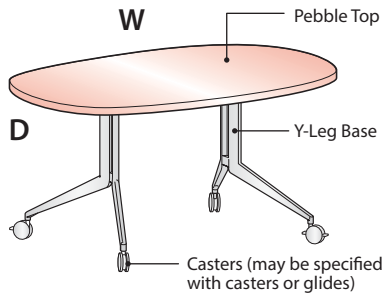

Non-Flip Top Table Sizes

		Width						
		60"	66"	72"	78"	84"	90"	96"
Depth	30"	●	●	●	N/A	N/A	N/A	N/A
	36"	●	●	●	●	●	●	●

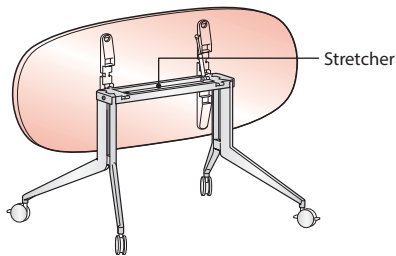

Flip Top Table Sizes

		Width		
		60"	66"	72"
Depth	30"	●	●	●
	36"	●	●	●

Edge Options for Laminate Tops

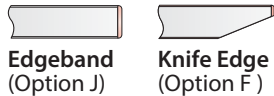

Edge Options for Wood Tops



Component Materials/Finishes

COMPONENT NAME	MATERIALS/FINISHES	
Pebble Top • Flip Top or Non-Flip Top • (S) Standard core only • Cutouts for Flip Top Units: (N) None (F) 4 Ports - Centered (J) 6 Ports - Centered	Laminate Top – Specify surface color and separate edge finish color (J) 3mm Edgeband (F) Knife Edge	
	Wood Top – Specify surface and edge finish color (K) Wood Edgeband (U) Wood Knife Edge	
Y-Leg Base and Stretcher	Painted Aluminum – Specify Base/Stretcher Trim Color	
Casters (Optional)	Casters are light platinum hub with graphite tread	
Glides (Optional)	Glides are light platinum, Stem is same finish as base trim color.	

Dimensions

Top View

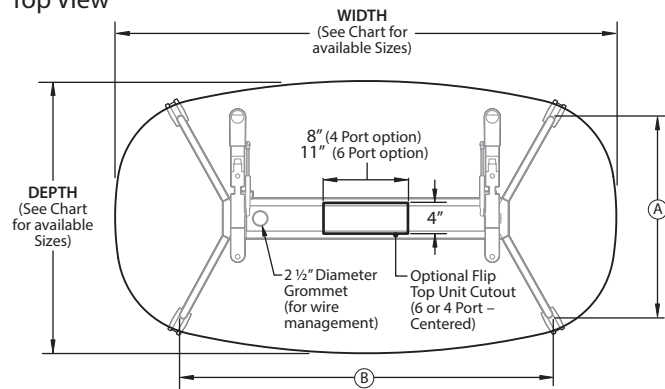

Front View

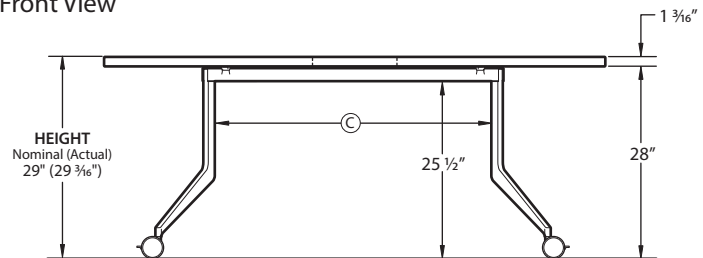

Note

- Optional Glides provide a 1/2" of adjustment for vertical leveling.
- A panel mounted worksurface and an adjacent freestanding table do not have the same level of adjustment to horizontally align worktops. Building floors with inherently uneven characteristics may also contribute this planning condition; plan accordingly.

Dimensions

TABLETOP		Y-LEG BASE		
Depth Nominal (Actual)	Width Nominal (Actual)	(A)	(B)	(C)
30" (29.68")	60" (59.68")	22 1/4"	45 7/8"	32 3/16"
	66" (65.68")	22 1/4"	47 7/8"	34 3/16"
	72" (71.68")	22 1/4"	53 7/8"	40 3/16"
36" (35.68")	60" (59.68")	28 1/2"	49 1/2"	32 3/16"
	66" (65.68")	28 1/2"	51 1/2"	34 3/16"
	72" (71.68")	28 1/2"	57 1/2"	40 3/16"
	78" (77.68")*	28 1/2"*	63 1/2"*	46 3/16"*
	84" (83.68")*	28 1/2"*	69 1/2"*	52 3/16"*
	90" (89.68")*	28 1/2"*	75 1/2"*	58 3/16"*
96" (95.68")*	28 1/2"*	77 1/2"*	60 3/16"*	

* Sizes only available with Non-Flip Table Tops

Product Details – Planes Collaborative Tables

Y-Leg Table – Hexagon Flip Top or Non-Flip Top

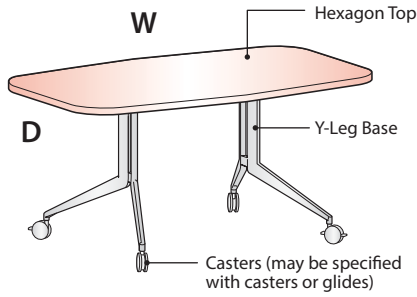

Non-Flip Top Table Sizes

		Width						
		60"	66"	72"	78"	84"	90"	96"
Depth	30"	●	●	●	N/A	N/A	N/A	N/A
	36"	●	●	●	●	●	●	●

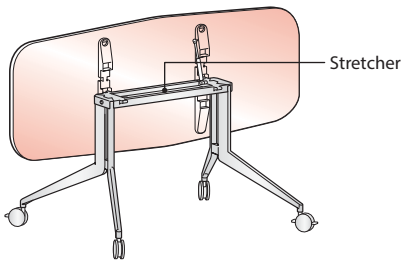

Flip Top Table Sizes

		Width		
		60"	66"	72"
Depth	30"	●	●	●
	36"	●	●	●

Edge Options for Laminate Tops

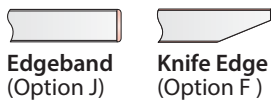

Edge Options for Wood Tops

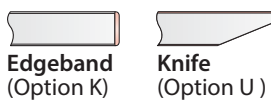

Component Materials/Finishes

COMPONENT NAME	MATERIALS/FINISHES	
Hexagon Top • Flip Top or Non-Flip Top • (S) Standard core only • Cutouts for Flip Top Units: (N) None (F) 4 Ports - Centered (J) 6 Ports - Centered	Laminate Top – Specify surface color and separate edge finish color	(J) 3mm Edgeband (F) Knife Edge
	Wood Top – Specify surface and edge finish color	(K) Wood Edgeband (U) Wood Knife Edge
Y-Leg Base and Stretcher	Painted Aluminum – Specify Base/Stretcher Trim Color	
Casters (Optional)	Casters are light platinum hub with graphite tread	
Glides (Optional)	Glides are light platinum, Stem is same finish as base trim color.	

Dimensions

Top View

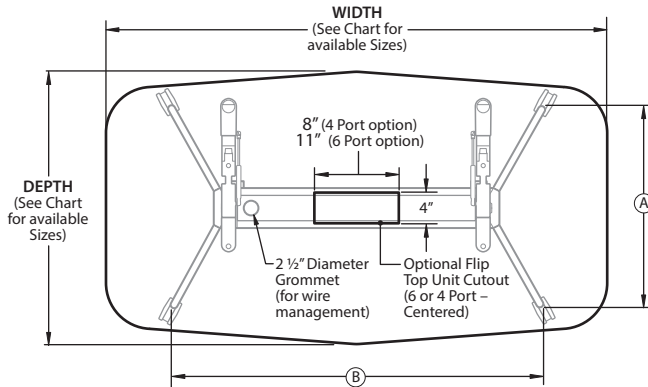

Front View

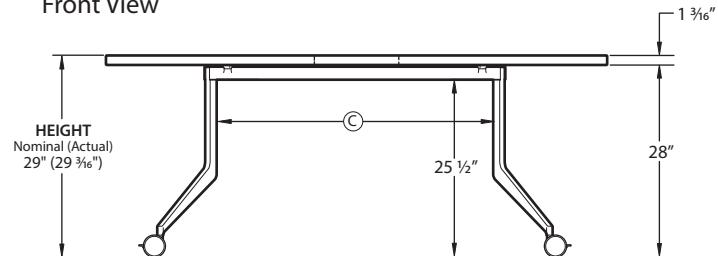

Note

- Optional Glides provide a 1/2" of adjustment for vertical leveling.
- A panel mounted worksurface and an adjacent freestanding table do not have the same level of adjustment to horizontally align worktops. Building floors with inherently uneven characteristics may also contribute this planning condition; plan accordingly.

Dimensions

TABLETOP		Y-LEG BASE		
Depth Nominal (Actual)	Width (Actual)	(A)	(B)	(C)
30" (29.68")	60" (59.68")	22 1/4"	45 7/8"	32 3/16"
	66" (65.68")	22 1/4"	47 7/8"	34 3/16"
	72" (71.68")	22 1/4"	53 7/8"	40 3/16"
36" (35.68")	60" (59.68")	28 1/2"	49 1/2"	32 3/16"
	66" (65.68")	28 1/2"	51 1/2"	34 3/16"
	72" (71.68")	28 1/2"	57 1/2"	40 3/16"
	78" (77.68")*	28 1/2"*	63 1/2"*	46 3/16"*
	84" (83.68")*	28 1/2"*	69 1/2"*	52 3/16"*
	90" (89.68")*	28 1/2"*	75 1/2"*	58 3/16"*
96" (95.68")*	28 1/2"*	77 1/2"*	60 3/16"*	

* Sizes only available with Non-Flip Table Tops

Product Details – Planes Collaborative Tables

Y-Leg Table – Half Round Flip Top or Non-Flip Top

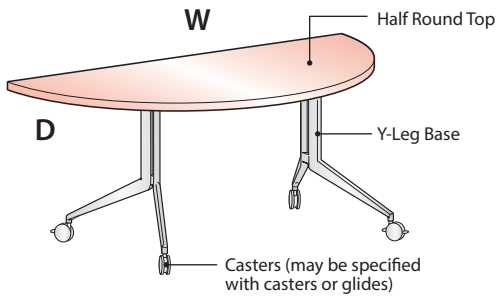

Non-Flip Top Table Sizes

		Width
		72"
Depth	36"	●

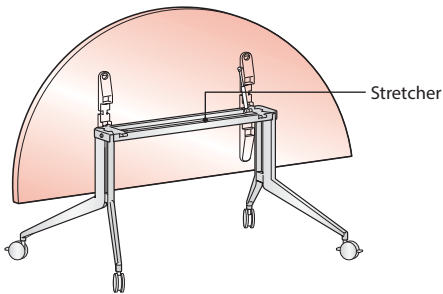

Flip Top Table Sizes

		Width
		72"
Depth	36"	●

Edge Options for Laminate Tops

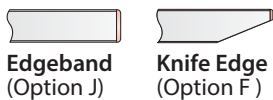

Edge Options for Wood Tops

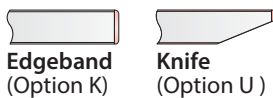

Component Materials/Finishes

COMPONENT NAME	MATERIALS/FINISHES	
Half Round Top • Flip Top or Non-Flip Top • (S) Standard core only • Cutouts for Flip Top Units: (N) None (F) 4 Ports - Centered (J) 6 Ports - Centered	Laminate Top – Specify surface color and separate edge finish color	(J) 3mm Edgeband (F) Knife Edge
	Wood Top – Specify surface and edge finish color	(K) Wood Edgeband (U) Wood Knife Edge
Y-Leg Base and Stretcher	Painted Aluminum – Specify Base/Stretcher Trim Color	
Casters (Optional)	Casters are light platinum hub with graphite tread	
Glides (Optional)	Glides are light platinum, Stem is same finish as base trim color.	

Dimensions

Top View

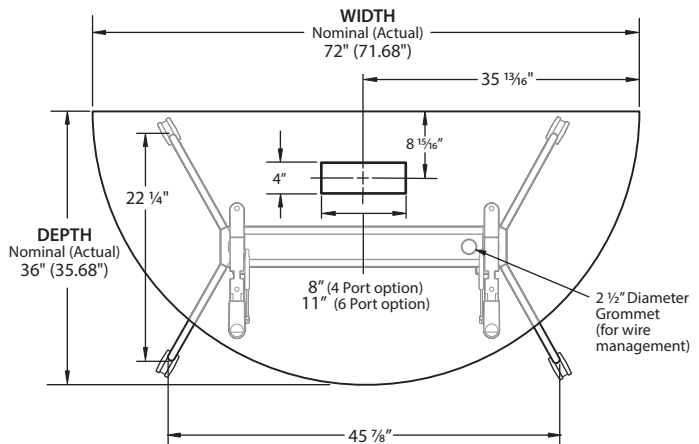

Front View

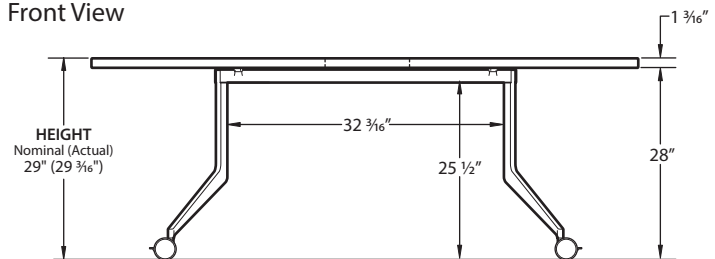

Note

- Optional Glides provide a 1/2" of adjustment for vertical leveling.
- A panel mounted worksurface and an adjacent freestanding table do not have the same level of adjustment to horizontally align worktops. Building floors with inherently uneven characteristics may also contribute this planning condition; plan accordingly.

Product Details – Planes Collaborative Tables

Y-Leg Table – Polygon Flip Top or Non-Flip Top

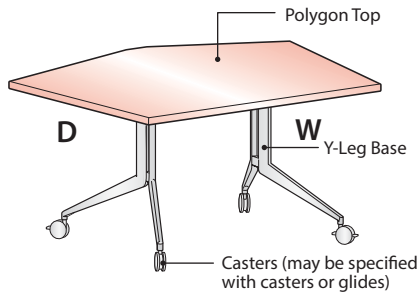

Non-Flip Top Table Sizes

		Width	
		60"	72"
Depth	30"	●	N/A
	36"	N/A	●

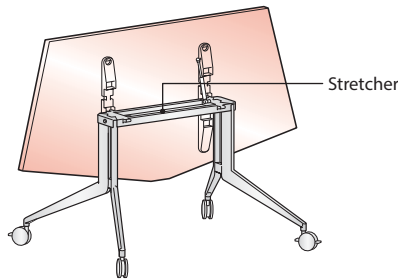

Flip Top Table Sizes

		Width	
		60"	72"
Depth	30"	●	N/A
	36"	N/A	●

Edge Options for Laminate Tops

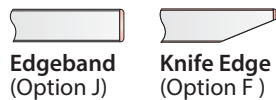

Edge Options for Wood Tops



Component Materials/Finishes

COMPONENT NAME	MATERIALS/FINISHES	
Polygon Top • Flip Top or Non-Flip Top • (S) Standard core only • Cutouts for Flip Top Units: (N) None (F) 4 Ports - Centered (J) 6 Ports - Centered	Laminate Top – Specify surface color and separate edge finish color	(J) 3mm Edgeband (F) Knife Edge
	Wood Top – Specify surface and edge finish color	(K) Wood Edgeband (U) Wood Knife Edge
Y-Leg Base and Stretcher	Painted Aluminum – Specify Base/Stretcher Trim Color	
Casters (Optional)	Casters are light platinum hub with graphite tread	
Glides (Optional)	Glides are light platinum, Stem is same finish as base trim color.	

Dimensions

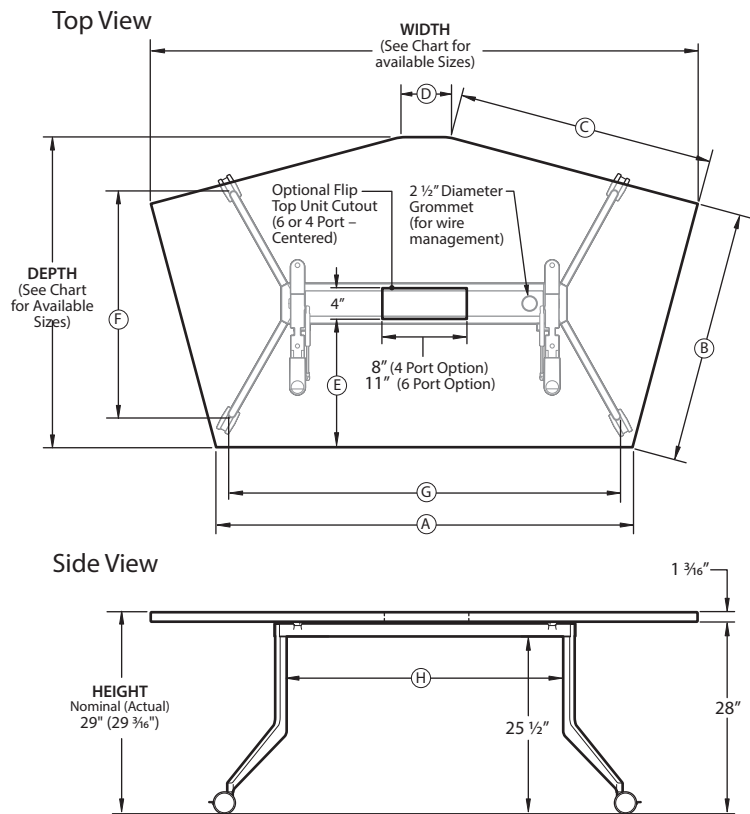

Note

- Optional Glides provide a 1/2" of adjustment for vertical leveling.
- A panel mounted worksurface and an adjacent freestanding table do not have the same level of adjustment to horizontally align worktops. Building floors with inherently uneven characteristics may also contribute this planning condition; plan accordingly.

Dimensions

TABLETOP		Y-LEG BASE							
Depth Nominal (Actual)	Width Nominal (Actual)	(A)	(B) Nominal (Actual)	(C) Nominal (Actual)	(D)	(E)	(F)	(G)	(H)
30"(36.56")	60"(65.90")	50 1/2"	30"(29.68")	30"(29.68")	8 1/2"	16 3/16"	22 1/4"	47 7/8"	34 1/4"
36"(43.90")	72"(77.43")	59"	36"(35.68")	36"(35.68")	8 1/2"	20"	28 1/2"	57 1/2"	40 1/4"

Product Details – Planes Collaborative Tables

Y-Leg Table – Sizes and Dimensions For Nested Tables in Flipped Position

Y-Leg Table Heights in the Flipped Position

Top Shape	30" Deep Table Height	36" Deep Table Height
Rectangle	46" High	49" High
Pebble	46" High	49" High
Hexagon	46" High	49" High
Half Round	46" High	49" High
Polygon	46 ¾" High	49 ¾" High

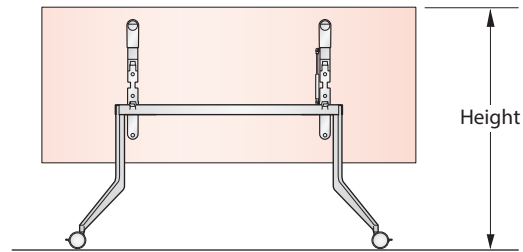

Nesting Tables in Flipped Position

When tables are nested in a staggered manner, it adds 10" to the depth and 4" to the width of the overall footprint for each table.

Example: If you have three 72" wide tables staggered, one table footprint is 30" deep and 72" wide. Each additional table adds 10" to the depth and 4" to the width. Three tables would have an overall footprint of 50" deep and 80" wide.

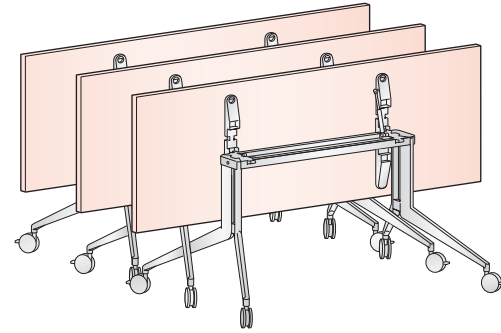

Dimensions for Three Nesting Tables

- Ⓐ = Depth of Y-Leg base
- Ⓑ = Additional depth for each nesting table
- Ⓒ = Additional width for each nesting table
- Ⓓ = Overall width of tables nesting
(will vary based on the width of the tables being nested)
- Ⓔ = Overall depth of tables nested
(will vary based on the number of tables being nested)

Table Width	Ⓐ	Ⓑ	Ⓒ	Ⓓ	Ⓔ
60"	30"	10"	4"	68"	50"
66"	30"	10"	4"	74"	50"
72"	30"	10"	4"	80"	50"

Top View

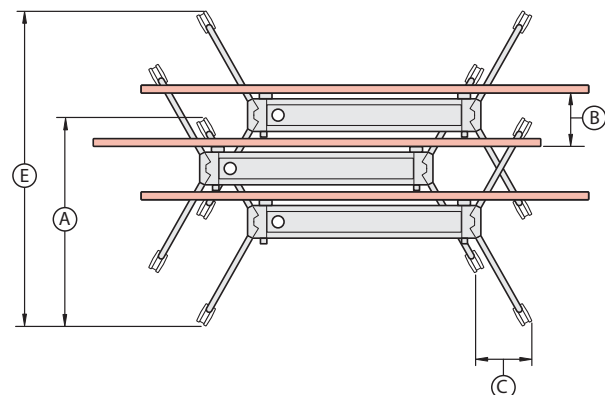
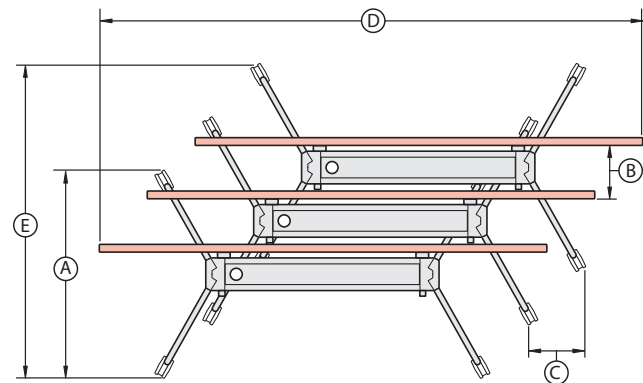

Note Example based upon nesting tables of same depths.

- Tips**
- Collaborative tables always have two Y-legs at the base.
 - Standard table height is 29" with 27 7/8" knee clearance.
 - Knee clearance under trough is 25 1/2".
 - 3mm edgeband is recommended for Collaborative Tables to allow for flat seams when pushing tables together.
 - Glides and casters are field interchangeable.
 - Optional Y-Leg bumper should be specified separately for nesting tables.

Product Details – Planes Collaborative Tables

X Base Tables – Overview

Planes X Base Collaborative Tables are ideal for a room whose purpose is constantly changing. X Base tables are available with single base and dual base tables in a wide variety of heights and top shapes. The tables can be reconfigured for multiple uses ranging from conferencing to collaborative to dining and everything in between.

X Base Table – Single Base

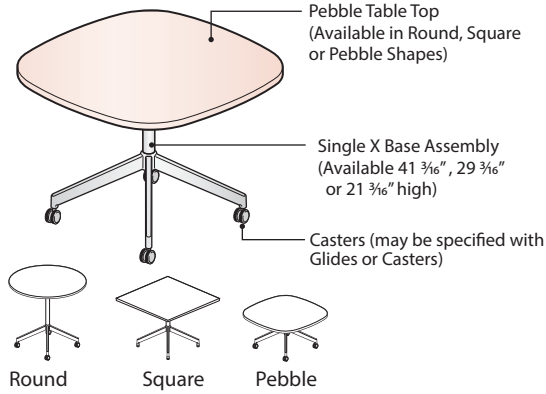

Wood Grain Direction

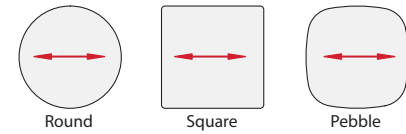

X Base Table – Dual Base

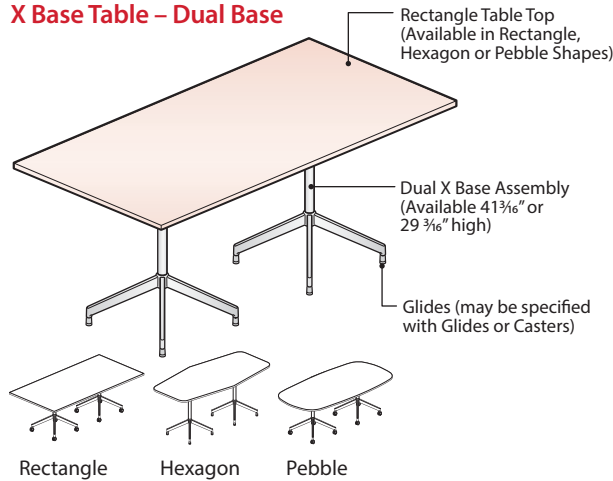

Wood Grain Direction

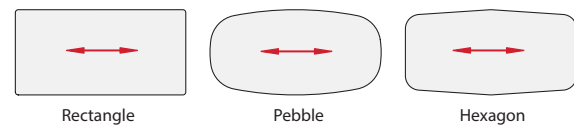

Edge Options for Laminate Tops

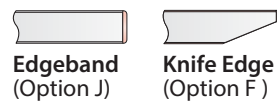

Edge Options for Wood Tops

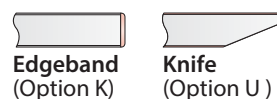

X Base Sizes

- The X Base is available with (2) sizes base sizes to accommodate small and large tops.

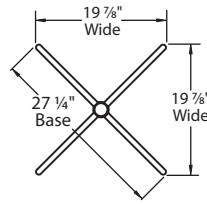

- Small X Base (27 1/4" Base)**
- 19 7/8" wide x 19 7/8" deep
 - For 30" and 36" deep tops

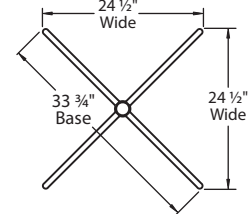

- Large X Base (33 3/4" Base)**
- 24 1/2" wide x 24 1/2" deep
 - For 42" and 48" deep tops

X Base Heights

- Single X Base Tables** are available in (3) heights: 41" (Standing), 29" (Seated) or 21" (Lounge)
- Dual X Base Tables** are available in (2) heights: 41" (Standing) or 29" (Seated)

41" High Tables

(Standing Height/Bar Height)

For use with most bar height seating (28"-30" seat heights) or standing applications.

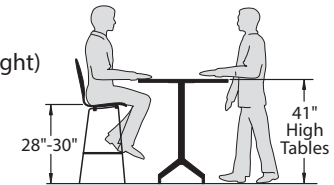

29" High Tables

(Seated Height)

For use with most standard seating (17"-18" seat heights).

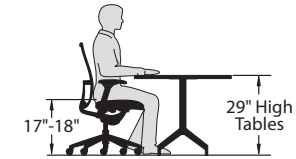

21" High Tables

(Lounge Height)

For use with most lounge seating (17"-18" seat heights).

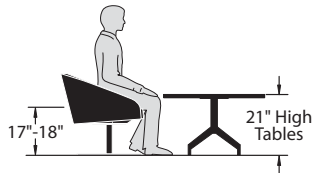

Caster/Glide Base Options

- X Base Tables may be specified with Glides or Casters.
- Glides and Casters are NOT field interchangeable.

(C) Caster Option

- Includes (2) locking and (2) non-locking casters for each base.

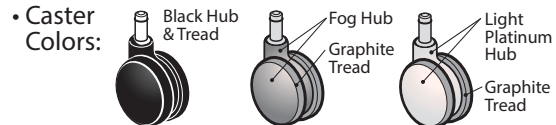

(G) Glide Option

- Includes (4) glides for each X Base, each glide provides 1/2" of vertical adjustment for leveling.

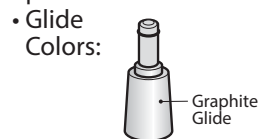

Product Details – Planes Collaborative Tables

X Base Table – Single Base

Round Top (41" high with Casters version shown)

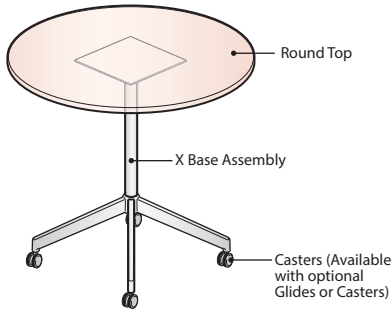

Square Top (29" high with Glides version shown)

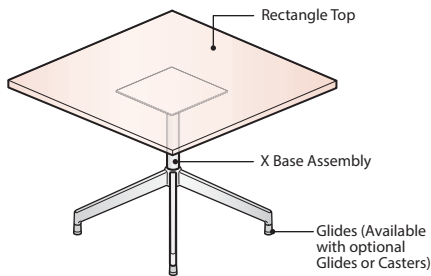

Pebble Top (21" high with Casters version shown)

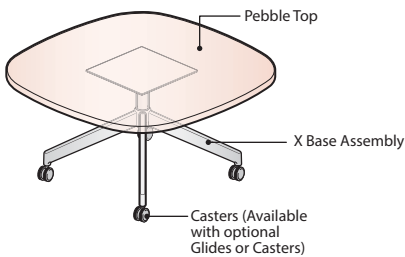

Component Materials/Finishes

COMPONENT NAME	MATERIALS/FINISHES	
Table Top • Top Shapes: – Round – Square – Pebble • (S) Standard core only	Laminate Top – Specify surface color and separate edge finish color	(J) Edgeband (F) Knife
	Wood Top – Specify a single surface and edge finish color	(K) Edgeband (U) Knife
X Base Assembly • Includes X Base and Post	Painted Aluminum – Specify Base trim color	
Casters (Optional)	Black hub with black tread	
	Fog hub with graphite tread	
	Light platinum hub with graphite tread	
Glides (Optional)	Glides standard in graphite finish	

Sizes and Dimensions

Tabletops (Round, Square or Pebble Shapes)		X Base Assembly		
Depth Nominal (Actual)	Width Nominal (Actual)	A	B	
			With Casters	With Glides
30" (29.68")	30" (29.68")	19 7/8"	10 9/16"	12 1/16"
36" (35.68")	36" (35.68")	19 7/8"	10 9/16"	12 1/16"
42" (41.68")	42" (41.68")	24 1/2"	12 1/16"	13 1/2"
48" (47.68")	48" (47.68")	24 1/2"	12 1/16"	13 1/2"

- Note**
- All Round, Square and Pebble shaped Single Base Tables may be specified in three heights (41", 29" or 21" high).
 - Glides and Casters are NOT field interchangeable.
 - Optional Glides provide a 1/2" of adjustment for vertical leveling.
 - A panel mounted worksurface and an adjacent freestanding table do not have the same level of adjustment to horizontally align worktops. Building floors with inherently uneven characteristics may also contribute this planning condition; plan accordingly.

Dimensions

Top View

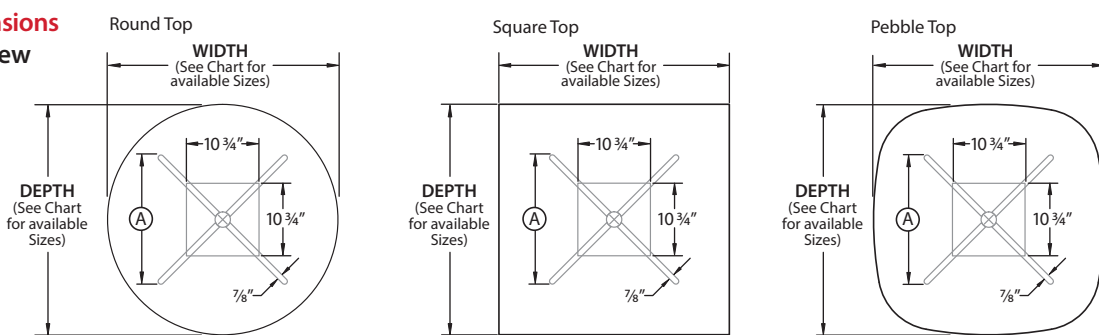

Front View

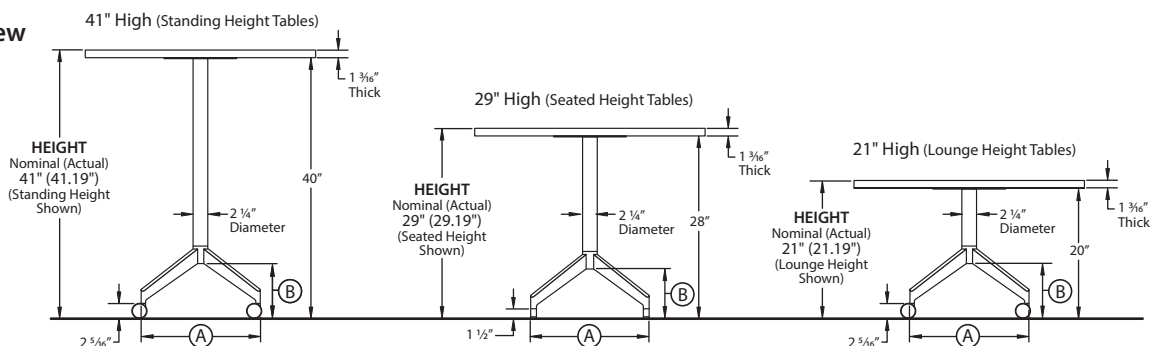

Product Details – Planes Collaborative Tables

X Base Table – Dual Base

Rectangle Top (41" high with Glides version shown)

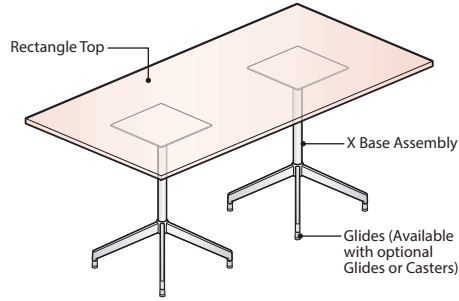

Hexagon Top (29" high with Casters version shown)

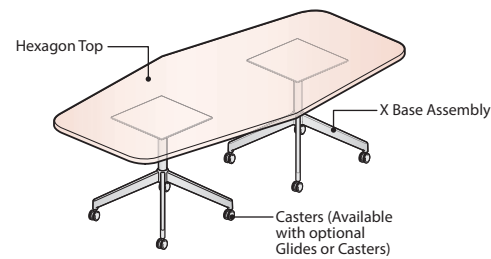

Pebble Top (29" high with Casters version shown)

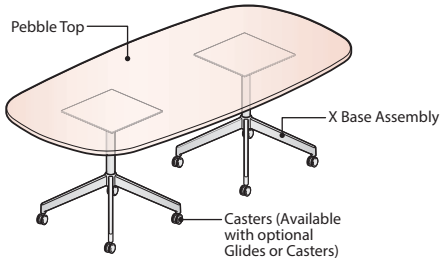

- Note**
- All X-Base Tables with Dual Bases may be specified with two heights (41" or 29" high).
 - A panel mounted worksurface and an adjacent freestanding table do not have the same level of adjustment to horizontally align worktops. Building floors with inherently uneven characteristics may also contribute this planning condition; plan accordingly.
 - Glides and Casters are NOT field interchangeable.

Dimensions

Top View

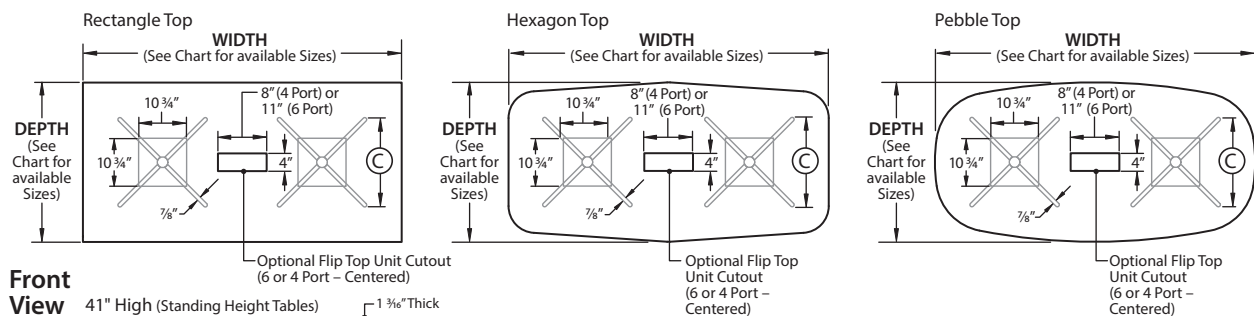

Front View

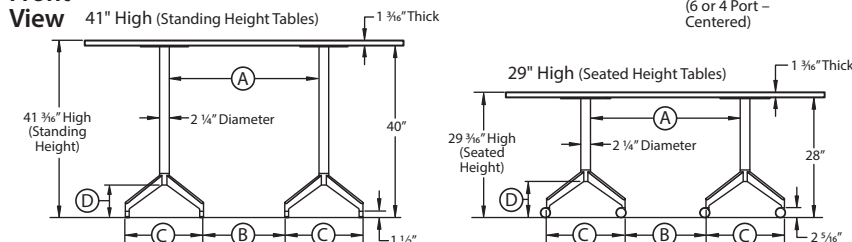

Component Materials/Finishes

COMPONENT NAME	MATERIALS/FINISHES	
Table Top • Top Shapes: – Rectangle – Hexagon – Pebble	Laminate Top – Specify surface color and separate edge finish color	(J) Edgeband (F) Knife
	Wood Top – Specify a single surface and edge finish color	(K) Edgeband (U) Knife
X Base Assembly • Includes X Base and Post	Painted Aluminum – Specify Base trim color	
Casters (Optional)	Black hub with black tread	
	Fog hub with graphite tread	
	Light platinum hub with graphite tread	
Glides (Optional)	Glides standard in graphite finish	

Sizes and Dimensions

Tabletops (Round, Square or Pebble Shapes)		Dual X Base Assembly				
Depth Nominal (Actual)	Widths Nominal (Actual)	A	B	C	D	
					With Casters	With Glides
30" (29.68")	60" (59.68")	27 9/16"	9 15/16"	19 7/8"	10 9/16"	12 1/16"
	66" (65.68")	30 9/16"	12 15/16"			
	72" (71.68")	33 9/16"	15 15/16"			
	78" (77.68")	36 9/16"	18 15/16"			
	84" (83.68")	39 9/16"	21 15/16"			
	90" (89.68")	42 9/16"	24 15/16"			
36" (35.68")	60" (59.68")	27 9/16"	9 15/16"	19 7/8"	10 9/16"	12 1/16"
	66" (65.68")	30 9/16"	12 15/16"			
	72" (71.68")	33 9/16"	15 15/16"			
	78" (77.68")	36 9/16"	18 15/16"			
	84" (83.68")	39 9/16"	21 15/16"			
	90" (89.68")	42 9/16"	24 15/16"			
42" (41.68")	60" (59.68")	27 9/16"	5 5/16"	24 1/2"	12 1/16"	13 1/2"
	66" (65.68")	30 9/16"	8 15/16"			
	72" (71.68")	33 9/16"	11 15/16"			
	78" (77.68")	36 9/16"	14 15/16"			
	84" (83.68")	39 9/16"	17 15/16"			
	90" (89.68")	42 9/16"	20 15/16"			
48" (47.68")	60" (59.68")	27 9/16"	5 5/16"	24 1/2"	12 1/16"	13 1/2"
	66" (65.68")	30 9/16"	8 15/16"			
	72" (71.68")	33 9/16"	11 15/16"			
	78" (77.68")	36 9/16"	14 15/16"			
	84" (83.68")	39 9/16"	17 15/16"			
	90" (89.68")	42 9/16"	20 15/16"			
96" (95.68")	60" (59.68")	27 9/16"	5 5/16"	24 1/2"	12 1/16"	13 1/2"
	66" (65.68")	30 9/16"	8 15/16"			
	72" (71.68")	33 9/16"	11 15/16"			
	78" (77.68")	36 9/16"	14 15/16"			
	84" (83.68")	39 9/16"	17 15/16"			
	90" (89.68")	42 9/16"	20 15/16"			

Product Details – Planes Collaborative Tables

Disc Base Tables – Overview

Planes Disc Base Collaborative Tables are ideal for a room whose purpose is constantly changing. Disc Base tables are available with single disc base tables and larger dual disc base tables with a wide variety of heights and top shapes. The tables can be reconfigured for multiple uses ranging from conferencing to collaborative to dining and everything in between.

Disc Base Table – Single Base

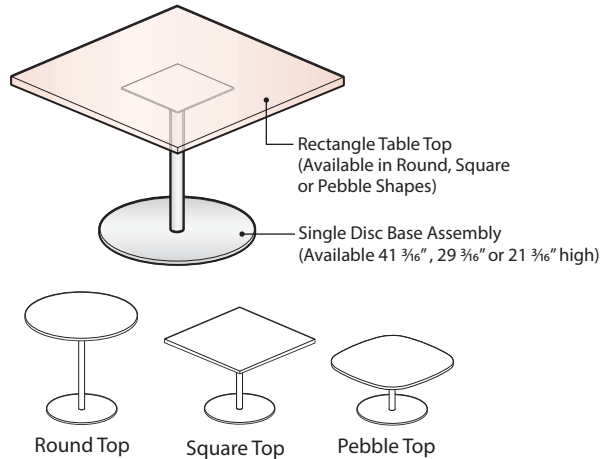

Wood Grain Direction

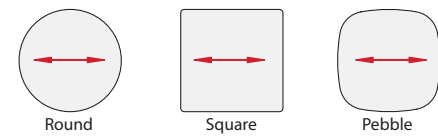

Disc Base Table – Dual Base

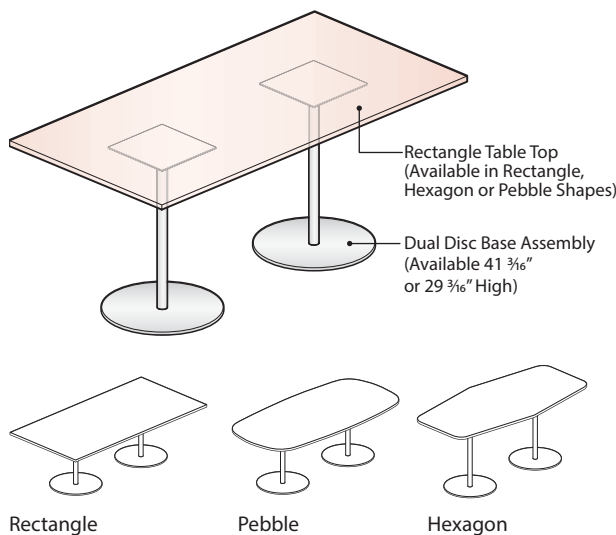

Wood Grain Direction

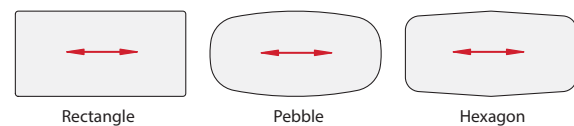

Disc Base Sizes

- The Disc Base is available with (2) sizes base sizes to accommodate small and large tops.

Top View

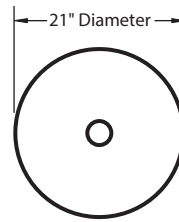

Small Disc Base

- 21" Diameter
- Included with 30" and 36" deep tops

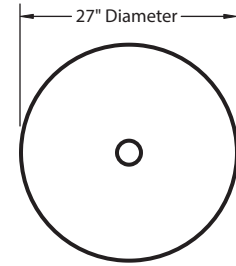

Large Disc Base

- 27" Diameter
- Included with all 42" and 48" deep tops

Disc Base Heights

- Single Disk Base Tables**
(3) heights: 41" (Standing), 29" (Seated) or 21" (Lounge)
- Dual Disk Base Tables**
(2) heights: 41" (Standing) or 29" (Seated)

41" High Tables (Standing Height/Bar Height)

For use with most bar height seating (28"-30" seat heights) or standing applications.

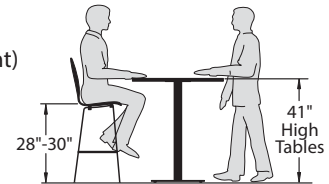

29" High Tables (Seated Height)

For use with most standard seating (17"-18" seat heights).

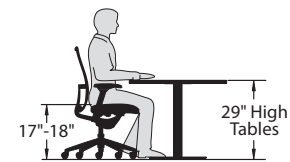

21" High Tables (Lounge Height)

For use with most lounge seating (17"-18" seat heights).

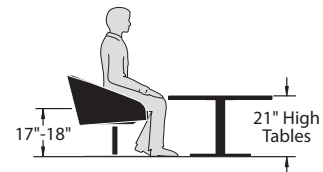

Edge Options for Laminate Tops



Edge Options for Wood Tops



Product Details – Planes Collaborative Tables

Disc Base Table – Single Base

Round Top (41" high version shown)

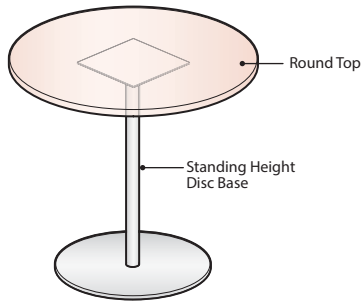

Square Top (29" high version shown)

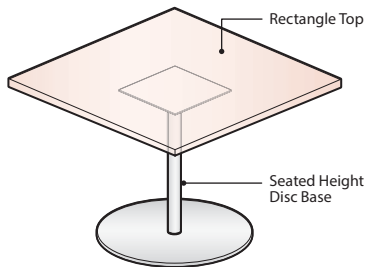

Pebble Top (21" high version shown)

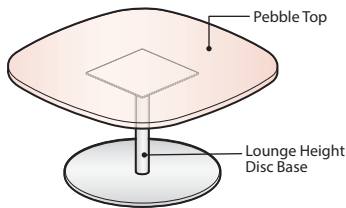

Component Materials/Finishes

COMPONENT NAME	MATERIALS/FINISHES	
Table Top • Top Shapes: – Round – Square – Pebble • (S) Standard core only	Laminate Top – Specify surface color and separate edge finish color	(J) Edgeband (F) Knife
	Wood Top – Specify surface and edge finish color	(K) Edgeband (U) Knife
Disc Base Assembly • Includes Disc Base, Center Post	Painted Aluminum – Specify Base trim color	

Sizes and Dimensions

Tabletops (Round, Square or Pebble Shapes)		Disc Base
Depth Nominal (Actual)	Width Nominal (Actual)	(A)
30" (29.68")	30" (29.68")	21"
36" (35.68")	36" (35.68")	21"
42" (41.68")	42" (41.68")	27"
48" (47.68")	48" (47.68")	27"

Note • A panel mounted worksurface and an adjacent freestanding table do not have the same level of adjustment to horizontally align worktops. Building floors with inherently uneven characteristics may also contribute this planning condition; plan accordingly.

Dimensions

Top View

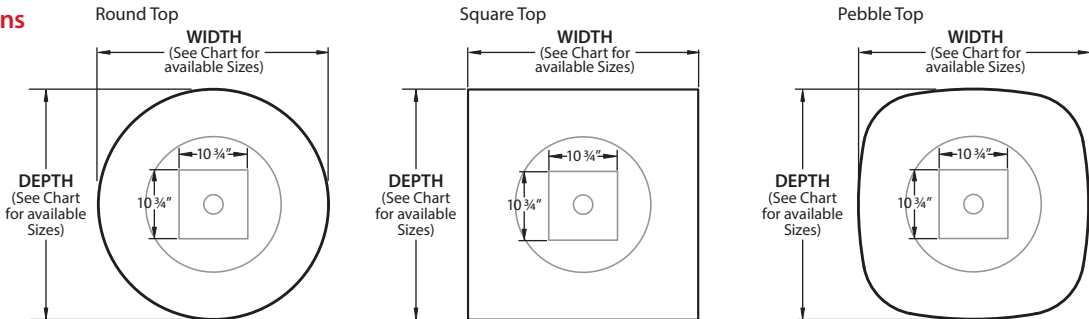

Front View

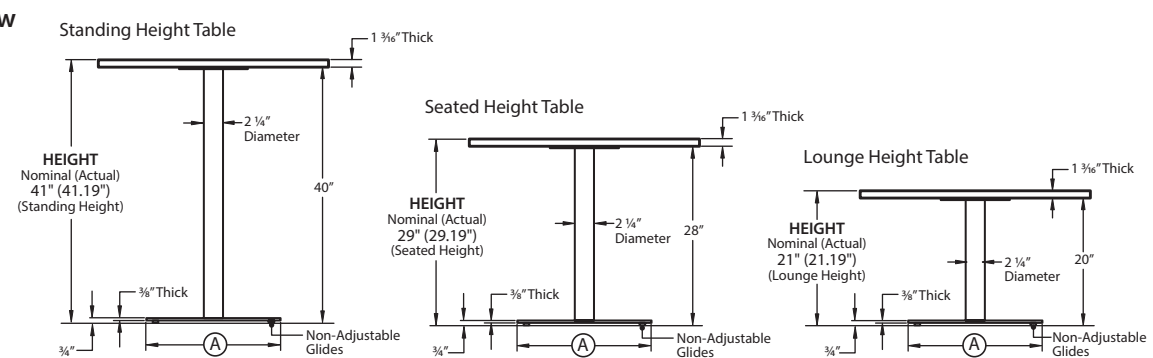

Product Details – Planes Collaborative Tables

Disc Base Table – Dual Base

Rectangle Top (41" high version shown)

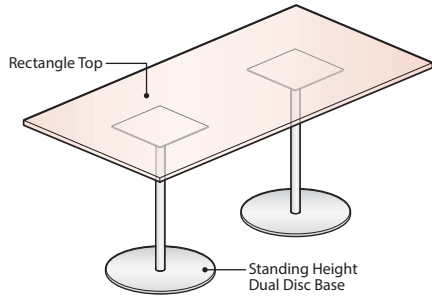

Hexagon Top (29" high version shown)

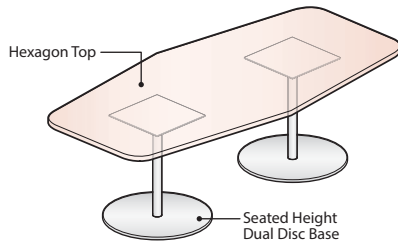

Pebble Top (29" high version shown)

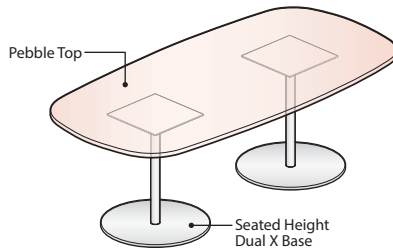

- Note**
- All Disc Base Tables with Dual Bases may be specified in two heights (41" or 29" high).
 - A panel mounted worksurface and an adjacent freestanding table do not have the same level of adjustment to horizontally align worktops. Building floors with inherently uneven characteristics may also contribute this planning condition; plan accordingly.

Dimensions

Top View

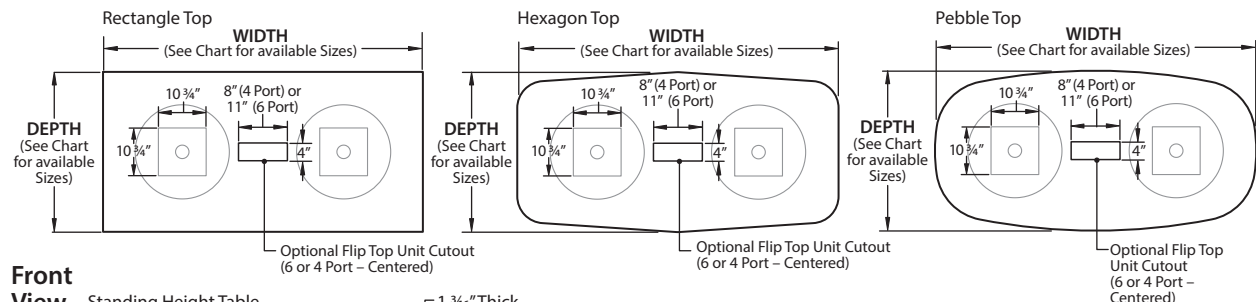

Front View

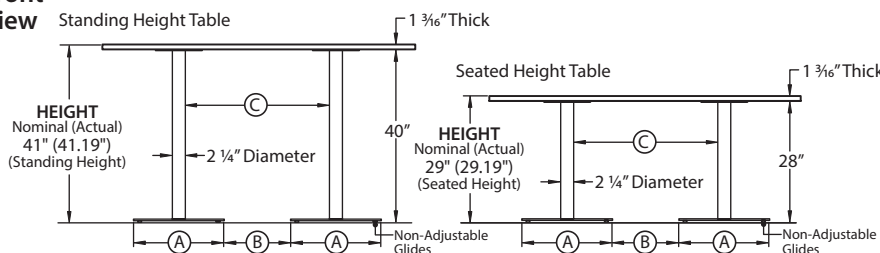

Component Materials/Finishes

COMPONENT NAME	MATERIALS/FINISHES	
Table Top • Top Shapes: – Rectangle – Hexagon – Pebble • (S) Standard core only	Laminate Top – Specify surface color and separate edge finish color	(J) Edgeband (F) Knife
	Wood Top – Specify surface and edge finish color	(K) Edgeband (U) Knife
Disc Base Assembly • Includes Disc Base, Center Post	Painted Aluminum – Specify Base trim color	

Sizes and Dimensions

Tabletops (Round, Square or Pebble Shapes)		Dual Disc Base		
Depth Nominal (Actual)	Widths Nominal (Actual)	(A)	(B)	(C)
30" (29.68")	60" (59.68")	21"	8 13/16"	26 7/8"
	66" (65.68")	21"	11 13/16"	29 7/8"
	72" (71.68")	21"	14 13/16"	32 7/8"
	78" (77.68")	21"	17 13/16"	35 7/8"
	84" (83.68")	21"	20 13/16"	38 7/8"
	90" (89.68")	21"	23 13/16"	41 7/8"
36" (35.68")	60" (59.68")	21"	8 13/16"	26 7/8"
	66" (65.68")	21"	11 13/16"	29 7/8"
	72" (71.68")	21"	14 13/16"	32 7/8"
	78" (77.68")	21"	17 13/16"	35 7/8"
	84" (83.68")	21"	20 13/16"	38 7/8"
	90" (89.68")	21"	23 13/16"	41 7/8"
42" (41.68")	60" (59.68")	27"	2 13/16"	26 7/8"
	66" (65.68")	27"	5 13/16"	29 7/8"
	72" (71.68")	27"	8 13/16"	32 7/8"
	78" (77.68")	27"	11 13/16"	35 7/8"
	84" (83.68")	27"	14 13/16"	38 7/8"
	90" (89.68")	27"	17 13/16"	41 7/8"
48" (47.68")	60" (59.68")	27"	2 13/16"	26 7/8"
	66" (65.68")	27"	5 13/16"	29 7/8"
	72" (71.68")	27"	8 13/16"	32 7/8"
	78" (77.68")	27"	11 13/16"	35 7/8"
	84" (83.68")	27"	14 13/16"	38 7/8"
	90" (89.68")	27"	17 13/16"	41 7/8"
96" (95.68")	60" (59.68")	27"	20 13/16"	44 7/8"
	96" (95.68")	27"	20 13/16"	44 7/8"

Product Details – Planes Collaborative Tables

Options and Features – Edge Options for Laminate and Wood Table Tops

Laminate Table Tops: 1 3/16" Thick

3mm Edgeband (J or F)

(Option J) Edgeband Side View

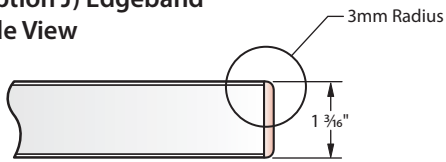

(Option F) Knife Side View

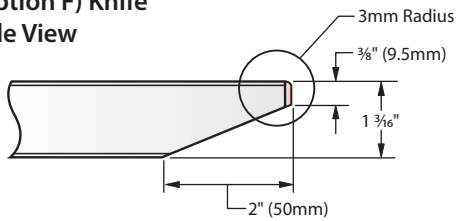

Wood Table Tops: 1 3/16" Thick

3mm Edgeband (K or U)

(Option K) Edgeband Side View

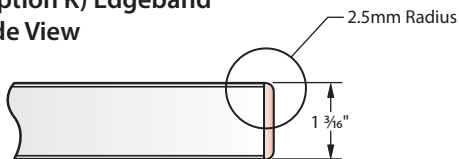

(Option U) Knife Side View

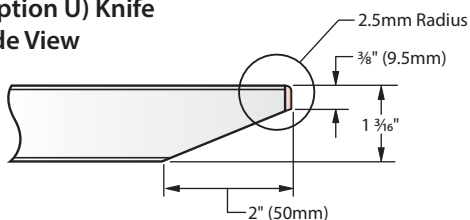

Note • Specified Edge Option on all sides.

Product Details – Planes Collaborative Tables

Power Components – Flip Top Units

- Planes Collaborative Tables may be specified with an optional Flip Top Unit Cutout, which requires a separately specified Single Sided Flip Top Unit to provide power on the table top.
- The Flip Top Unit spring release cover offers two positions; closed or fully open.
- Order Flip Top Units to match flip top unit cutout option specified for each table.
- Flip Top Unit: bezel and pop-up portion are proud to table top
- When installed into a 1 3/16" thick table top:
 - Receptacles project 1" above the table top when fully opened
 - The Flip Top Unit will extend below the top
- Available with reduced PVC content.

Flip Top Unit – 8 5/16" Wide (4 Ports)

Closed

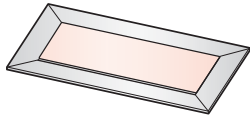

Fully Open

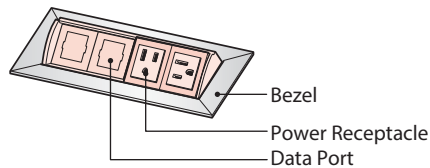

Flip Top Unit – 11 1/4" Wide (6 Ports)

Closed

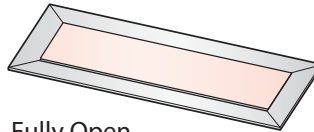

Fully Open

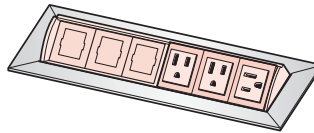

Dimensions – Top View

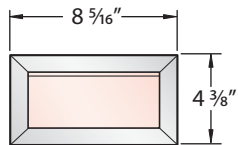

4 Port Flip Top Unit

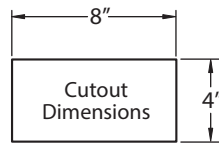

Cutout Option (F)
Centered – Single-Sided
4 Ports

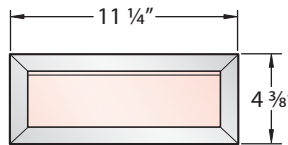

6 Port Flip Top Unit

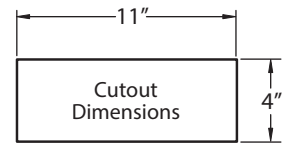

Cutout Option (J)
Centered – Single-Sided
6 Ports

Dimensions – End View

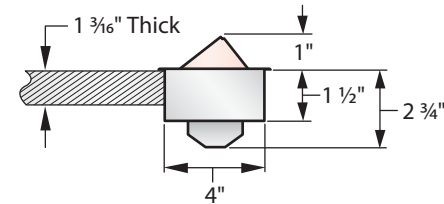

Single Sided Flip Top Units for use with Planes Collaborative Tables

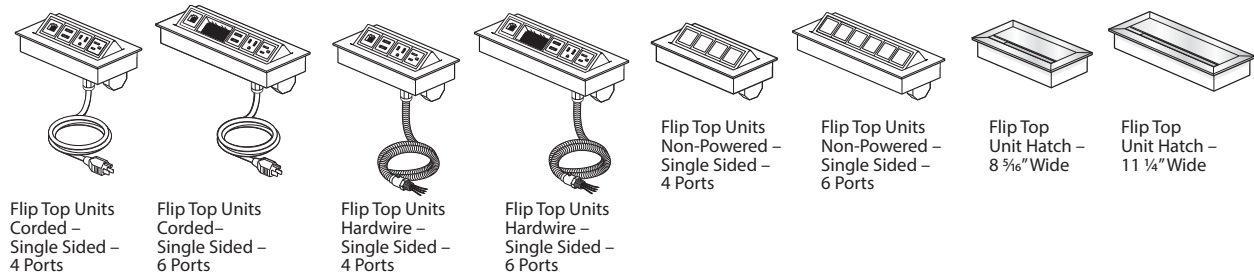

Note Additional Power Modules may be used with Collaborative Tables. The cutouts must be field cut or ordered through tailored solutions. See Power Module Price List page for specific cut out sizes.

- Tips**
- Flip Top Unit is field installed into a factory cut opening.
 - For use with 120 volt 60 hertz power source only.
 - Application may require approval of local authority having jurisdiction (AHJ); ensure compliance before ordering and installation.

Product Details – Planes Collaborative Tables

Power Components – Flip Top Units

Wire Management Guidelines for Y Leg Tables with Flip Top Units

- Specify Y-Leg Table with desired Flip Top Unit cutout size.
- Separately specify Flip-top Unit(s) to match cutout size.
- Position Flip Top Unit in cutout and route cord into the stretcher and out through one of the Grommets on either side of the stretcher.
- Vertical Wire Management (TAO1-0212) may be separately specified to conceal the cord through the Leg.

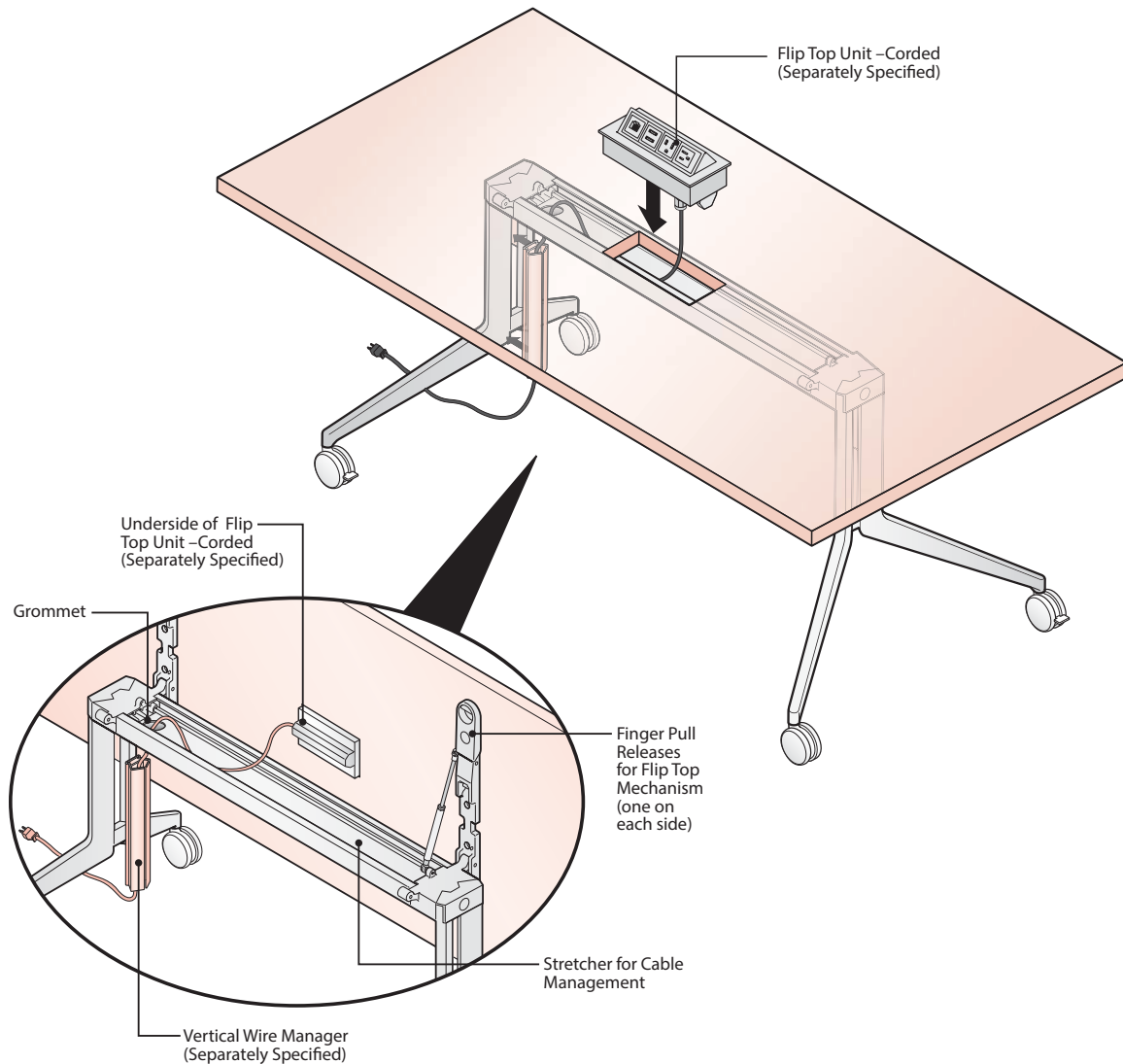

Product Details – Planes Collaborative Tables

Power Components – Flush Mount Power Module

Flush Mounted Power Modules Configurations

- The Flush Mount Power Module are available in 3, 4 or 6 Port configurations and can be configured with several combinations of power receptacles, USB charging, data ports or cable bays (See price list for available port configurations).
- Power port includes 15 Amp 120V 60Hertz rated receptacle NEMA 5-15R configuration
- USB charger port includes two USB 2.0 style A outlets with 4.0 Amp (shared) charging capacity
- Data Port accommodates various data and A/V connector with provided adapters.
- Cable Bay uses two port locations and provides two 9/16" grommets for routing cables through Flush Mount body. Recessed cavity provides 2" deep cavity to stow cable head.
- Port configurations may NOT be modified in the field.
- Provided with brackets to mount to 3/4" - 1 3/4" thick surface
- Color option of black painted bezel with black receptacles or white painted bezel with white receptacles.
- Installation requires field installed cutout on table top.
- Corded configurations are available with SJT power cord with 15A plug (NEMA 5-15P) 6' or 12' long. Corded modules with 4 or more power receptacle ports are standard with Circuit Breaker Plug.
- Hardwired configurations are available with flexible galvanized steel conduit 6' or 12' long with fitting for 1/2" knockout.

3-Port Flush Mounted Power Module

- Optional hardwired version shown.
- Shown (2) Power Receptacles and (1) USB Charging port

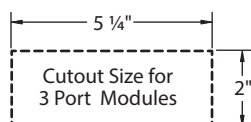
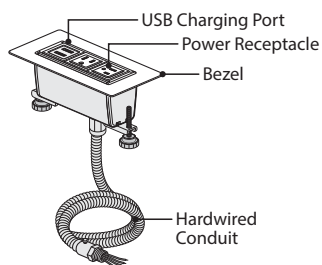

4-Port Flush Mounted Power Module

- Optional corded version with Circuit Breaker Plug shown.
- Shown with (4) Power Receptacles.

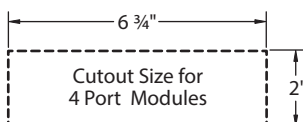
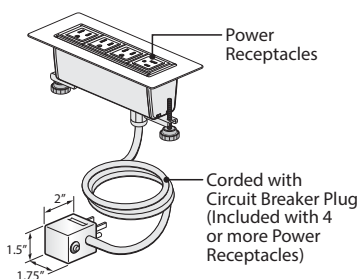

6-Port Flush Mounted Power Module

- Optional corded version shown.
- Shown with (1) Cable Bay, (1) Data Port, (1) USB Charging Port, and (2) Power Receptacles

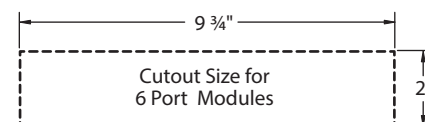
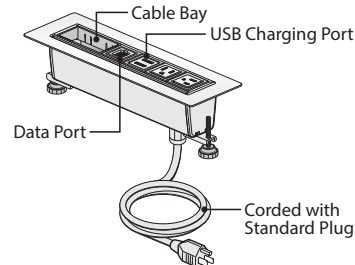

Flush Mounted Power Module Dimensions

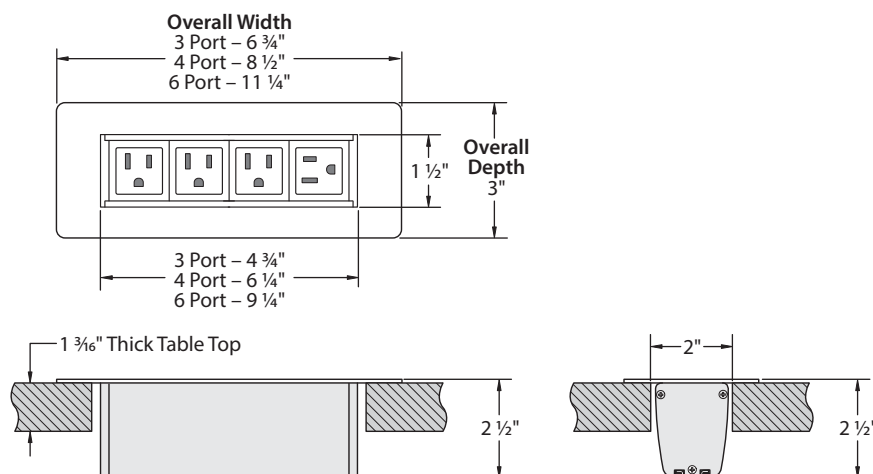

Product Details – Planes Collaborative Tables

Power Components – Bezel Utility Module

- Includes: Either a round or square faced Power Module and mounting hardware.
- Power configuration includes one cord with plug (NEMA 5-15P) round or square faced Power Module and mounting hardware (6' or 12' cord available).
- USB configuration includes one cord with voltage transformer plug round or square faced Power Module with two USB ports providing 1000mA of charging power (5 volts) per USB outlet and mounting hardware.
- For use on surfaces $\frac{3}{4}$ "-2" thick.
- For use with 120 volt 60 hertz power source only.
- Requires field cut $1\frac{3}{4}$ " hole and field installation.
- Application may require approval of local authority having jurisdiction (AHJ); ensure compliance before placing orders and installing.

Component Materials/Finishes

COMPONENT NAME	MATERIALS/ FINISHES
USB Outlet	<ul style="list-style-type: none"> • Available with a (B) Black or (W) White Bezel. • UL Listed provides one NEMA 5-15R Outlet.
Power Outlet	<ul style="list-style-type: none"> • Available with a (B) Black or (W) White Bezel. • USB outlet consists of two USB outlets with 1000mA of charging per USB outlet powered from UL listed transformer.
Cord with Voltage Transformer and Plug	<ul style="list-style-type: none"> • Black cord, transformer/plug
Cord with Plug	<ul style="list-style-type: none"> • White cord/plug

Bezel Utility Module – Power

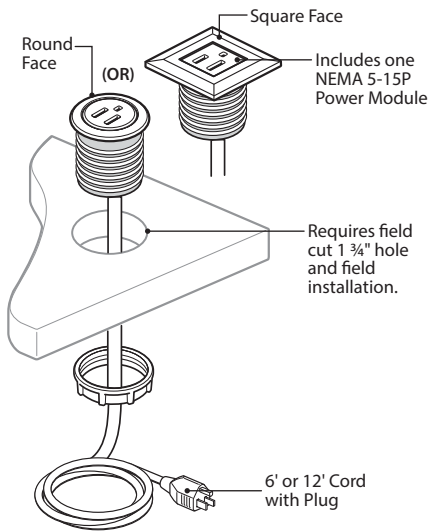

Bezel Utility Module – USB

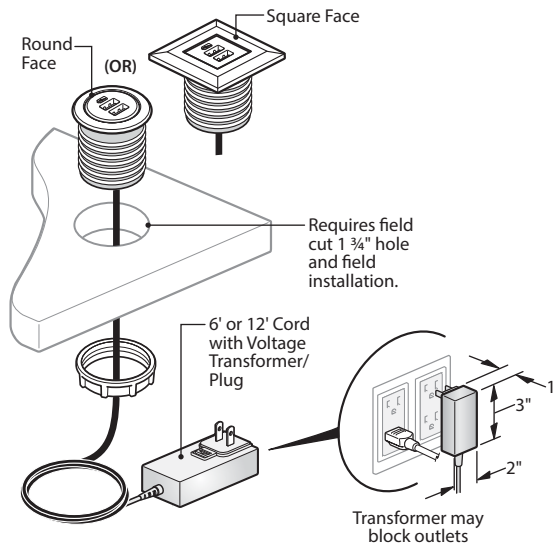

Power Receptacle

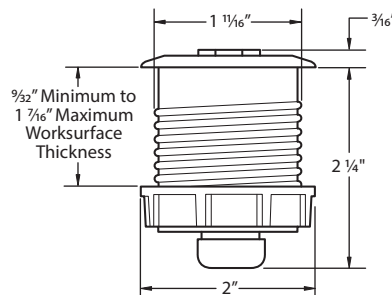
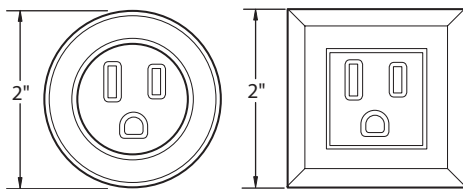

USB Charger

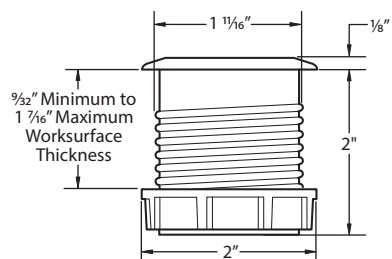
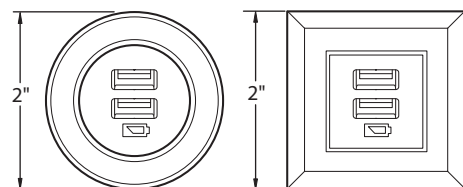

Product Details – Planes Collaborative Tables

Power Components – Power Tap – Corded

- A Power Tap includes three 15A receptacle outlets (MEMA 5-15R) with cord and plug (15A NEMA 5-15-P).
- Requires separately specified mounting brackets to provide above or below worksurface power access.
- For use with 120 volt 60 hertz power source only.
- Available with cord lengths of 6', 9', 15' or 25'.
- Power Tap applications should be reviewed by local authorities (electrical inspector) prior to ordering due to varying local codes.

Component Materials/Finishes

COMPONENT NAME	MATERIALS/ FINISHES
Power Tap Housing and Receptacles	Available Trim Colors: • (TR-K) Charcoal • (TR-J) Graphite
Cord with Plug	• Standard in black

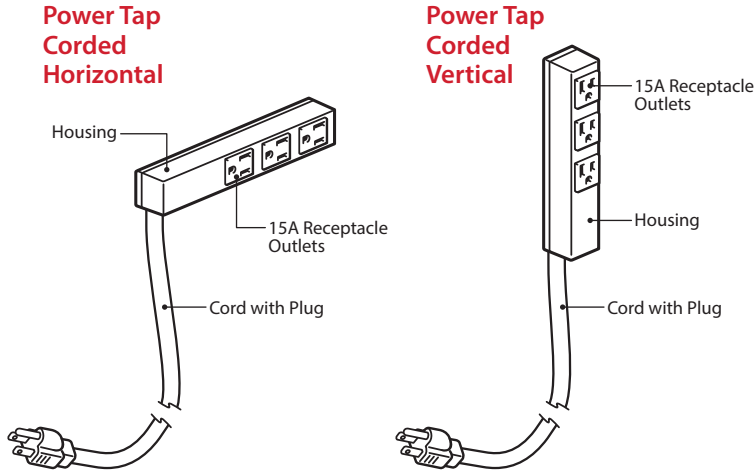

Dimensions

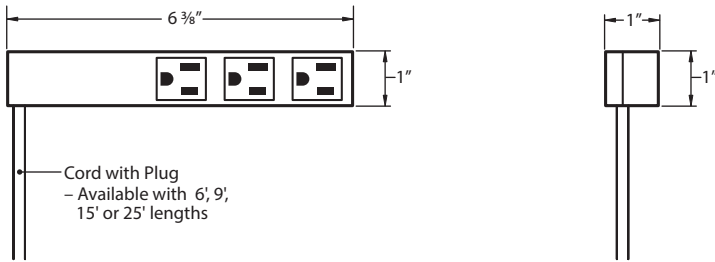

Mounting Options

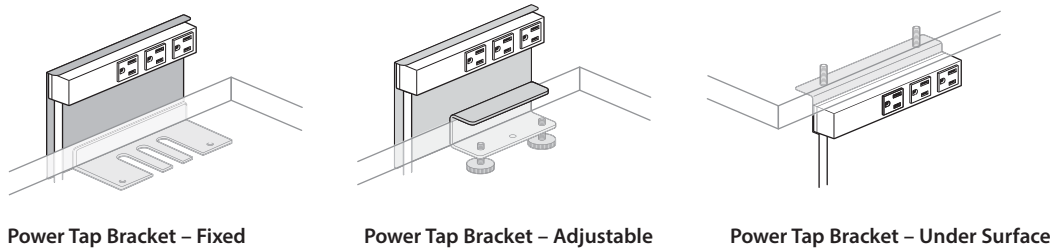

Product Details – Planes Collaborative Tables

Power Components – workware Interface Module – Non-Switching

workware Interface Module – Non-Switching Configurations

- The Workware Interface Module can be configured with several combinations of power receptacles, USB charging, data ports or cable bays. See price book for specific combinations available.
- Power receptacle ports include 15 Amp 120V 60Hertz rated receptacle NEMA 5-15R configuration.
- USB charger port includes two USB 2.0 style A outlets with 4.0 Amp (shared) charging capacity.
- Data Ports accommodate various data and A/V connector with provided adapters.
- Cable Bays use two port locations and provides two $\frac{9}{16}$ " grommets for routing cables through Flush Mount body. Recessed cavity provides 2" deep cavity to stow cable head.
- Port configurations may NOT be modified in the field.
- Corded configurations are available with SJT power cord with 15A plug (NEMA 5-15P) 6' or 12' long. Corded modules with 4 or more power receptacle ports are standard with Circuit Breaker Plug.
- Hardwired configurations are available with flexible galvanized steel conduit 6' or 12' long.
- Provided with mounting brackets to mount to $\frac{3}{4}$ " thick or greater wood, particle board or MDF worksurface.
- Available in clear anodized aluminum body with black ports or painted exterior with black ports.
- Requires field cutting or specification of factory cut option.

4-Port – Narrow

- Corded version shown.
- Port Configuration:
(2) Power Receptacles
(2) Data Ports

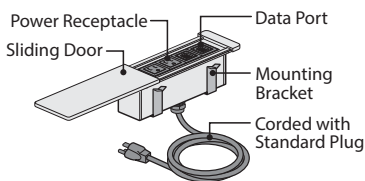

Top View

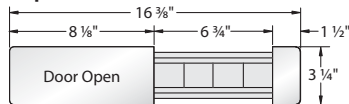

Cutout Dimensions

Cutout must be field cut.

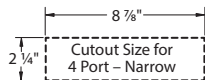

Front View

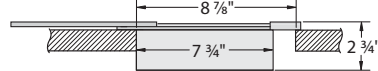

6-Port – Narrow

- Corded version with Circuit Breaker Plug shown.
- Port Configuration:
(4) Power Receptacles
(1) Cable Bay

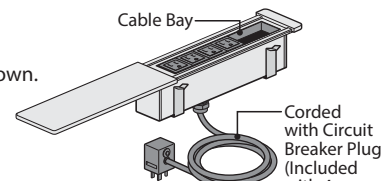

Top View

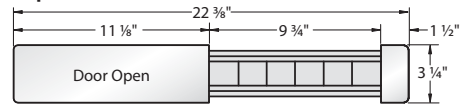

Cutout Dimensions

• Cutout must be field cut.

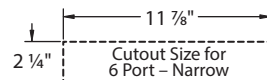

Front View

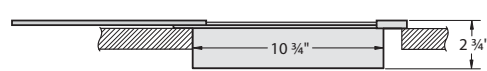

4-Port – Wide

- Hardwired version shown.
- Port Configuration:
(2) Power Receptacles
(1) USB Charging Port
(1) Data Port

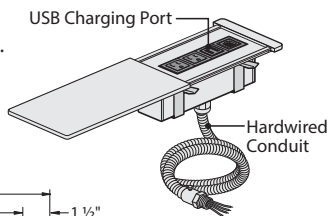

Top View

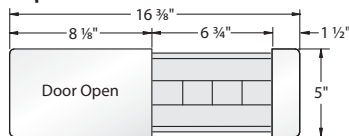

Cutout Dimensions

Factory Cutout Option:

(F) Center – Single-Sided/4 Ports

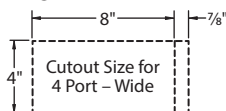

Front View



6-Port – Wide

- Corded version with Circuit Breaker Plug shown.
- Port Configuration:
(4) Power Receptacles
(1) Cable Bay

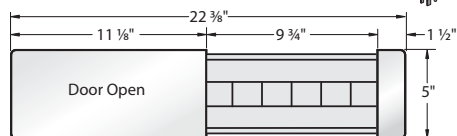
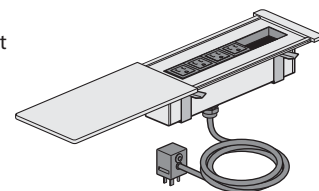

Cutout Dimensions

Factory Cutout Option:

(J) Center – Single-Sided/6 Ports

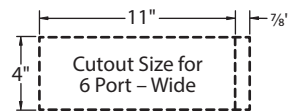

Front View



Note If a phone line needs to be routed through the communication opening on the end of the unit, the standard cutouts must be field modified to add $\frac{7}{8}$ " to the width of the cutout.

Product Details – Planes Training Tables

Overview

Create effective education environments with Planes Training Tables. From dedicated training rooms to multi-purpose spaces, Planes Training Tables provide the top shapes, sizes and options to support a variety of instructional applications and settings. With table options that include casters, tops that flip and hinged modesty panels, Planes Training Tables provide easy mobility. In addition, Planes Training Tables blend technology and reconfiguration needs by offering power distribution system options with integrated wire management.

Training Table Top Shapes

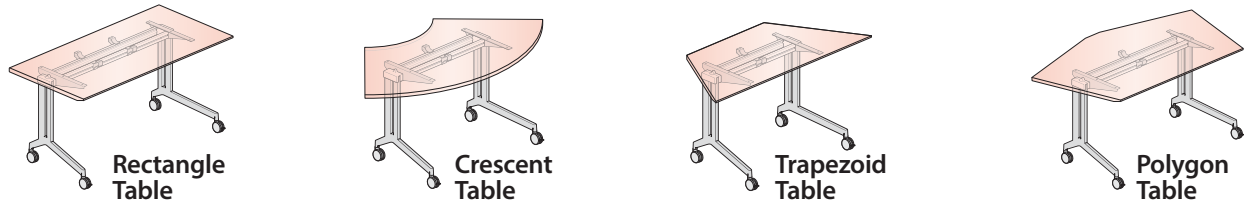

Flip Top Tables

- Training Tables are available with a flip top option that allows the tops to flip up so tables can nest for easy storage.
- To flip the table top to the upright position, pull the left and right side finger pulls that release locks to allow pneumatic assisted flip action.
- To return top to horizontal position, push/pull down on table top edge and top locks back into horizontal position.

Integrated Wire Management

- A Stretcher runs between the two C-legs in the base of the Training Tables for lay-in cable management.
- This Stretcher has an elliptical shaped grommet on each side, approximately 3/4" x 1 7/8", to allow access to an outside power source or to distribute power between tables when one of the power distribution systems is in use.
- Wires can be routed vertically using the optional C-leg Vertical Wire Manager.

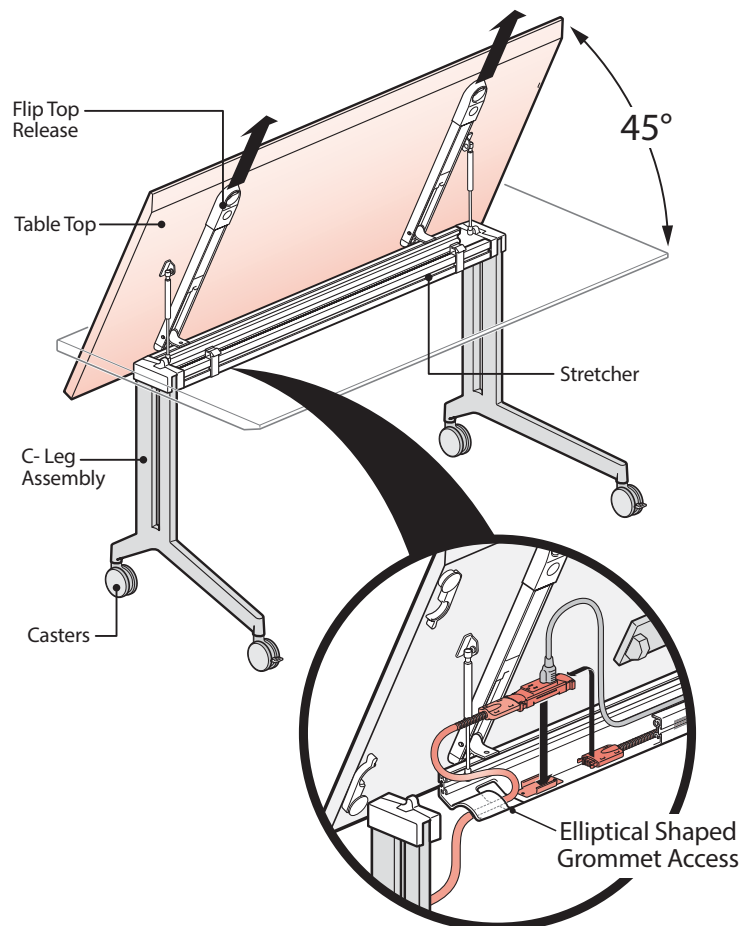

Stretcher detail with integrated wire management (shown with 2-Circuit Power)

Product Details – Planes Training Tables

Overview

Leg Options

- The leg may be specified with a (A) Painted or (B) Polished Aluminum Finish. The stretcher and support arms will be powdercoat painted.
- Tables specified with casters come with 2 locking casters and two non-locking casters. Casters are available in three color combinations: light platinum hub with graphite tread, fog hub with graphite tread or black hub with black tread.
- Tables specified with glides come with 4 glides with ½" adjustment.

Caster Finish Options

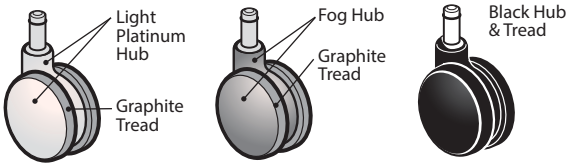

Glide Finish Options

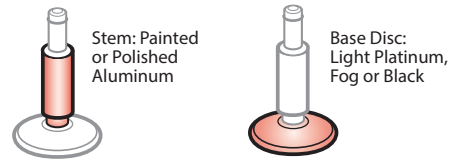

Wood Grain Direction

- The red arrows indicate wood grain direction for each of the top shapes.
- Fore additional finish information see the Planes Table Finish/Color Legend at the back of the price book

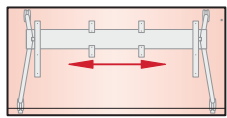

Rectangle

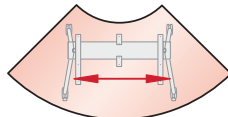

Crescent

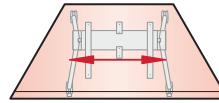

Trapezoid

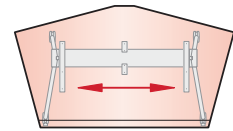

Polygon

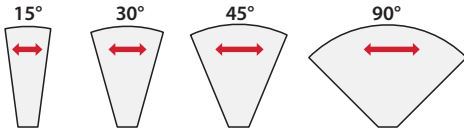

Pie Connectors

Product Details – Planes Training Tables

Rectangular – Flip Top or Non-Flip Top Training Table

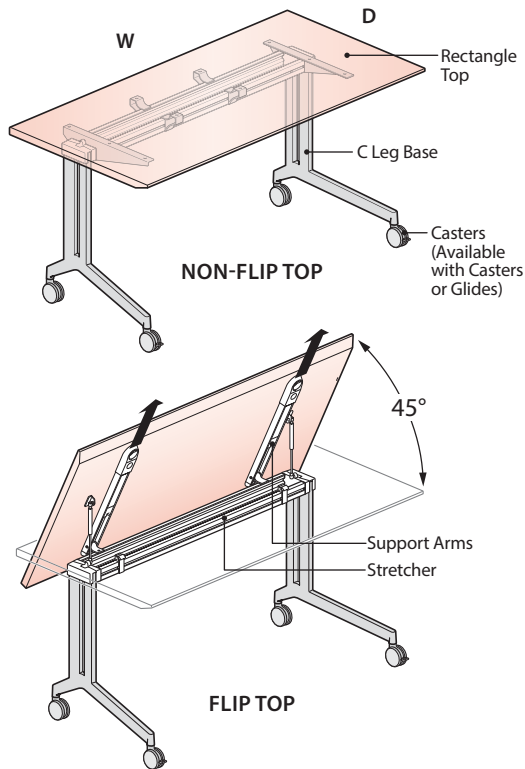

Component Materials/Finishes

COMPONENT NAME		MATERIALS/FINISHES
Rectangle Table Top	• Flip Top or Non-Flip Top	Laminate Top • Specify surface color and separate edge trim color. (J) Edgeband • 3mm edgeband on all edges. (F) Knife Edge • Knife Edge on user edge only 3mm edgeband on sides and back.
		Wood Top • Specify wood finish color for surface and edgeband. (K) Wood Edgeband • 3mm edgeband on all edges. (U) Wood Knife Edge • Knife Edge on user edge only 3mm edgeband on sides and back.
C Leg Base, Stretcher, Brackets and Support Arms		(A) Painted Aluminum • C Leg, stretcher, brackets and support arms are painted and require a trim color specification.
		(B) Polished Aluminum • C Leg base and glide stem are polished aluminum. • Stretcher, brackets and support arms are painted and require a trim color specification.
Casters (Optional)		Black hub with black tread
		Fog hub with graphite tread
		Light platinum hub with graphite tread
Glides (Optional)	Glide Disc Base	Available in black, fog, or light platinum.
	Glide Stem	Painted or polished to match base.

Available Sizes and Dimensions

TABLETOP		C-LEG BASE			
Depth Nominal (Actual)	Width Nominal (Actual)	(A)	(B)	(C)	(D)
20" (19.68")	36" (35.68")	8 7/16"	20 7/8"	25 7/16"	18 1/8"
	42" (41.68")	8 7/16"	26 7/8"	31 7/16"	18 1/8"
	48" (47.68")	8 7/16"	32 7/8"	37 7/16"	18 1/8"
	54" (53.68")	8 7/16"	38 7/8"	43 7/16"	18 1/8"
	60" (59.68")	8 7/16"	44 7/8"	49 7/16"	18 1/8"
	66" (65.68")	8 7/16"	50 7/8"	55 7/16"	18 1/8"
	72" (71.68")	8 7/16"	56 7/8"	61 7/16"	18 1/8"
	78" (77.68")	8 7/16"	62 7/8"	67 7/16"	18 1/8"
	84" (83.68")	8 7/16"	68 7/8"	73 7/16"	18 1/8"
	90" (89.68")	8 7/16"	74 7/8"	79 7/16"	18 1/8"
24" (23.68")	36" (35.68")	12 7/16"	20 7/8"	25 7/16"	18 1/8"
	42" (41.68")	12 7/16"	26 7/8"	31 7/16"	18 1/8"
	48" (47.68")	12 7/16"	32 7/8"	37 7/16"	18 1/8"
	54" (53.68")	12 7/16"	38 7/8"	43 7/16"	18 1/8"
	60" (59.68")	12 7/16"	44 7/8"	49 7/16"	18 1/8"
	66" (65.68")	12 7/16"	50 7/8"	55 7/16"	18 1/8"
	72" (71.68")	12 7/16"	56 7/8"	61 7/16"	18 1/8"
	78" (77.68")	12 7/16"	62 7/8"	67 7/16"	18 1/8"
	84" (83.68")	12 7/16"	68 7/8"	73 7/16"	18 1/8"
	90" (89.68")	12 7/16"	74 7/8"	79 7/16"	18 1/8"
30" (29.68")	36" (35.68")	18 7/16"	20 7/8"	25 7/16"	24 1/8"
	42" (41.68")	18 7/16"	26 7/8"	31 7/16"	24 1/8"
	48" (47.68")	18 7/16"	32 7/8"	37 7/16"	24 1/8"
	54" (53.68")	18 7/16"	38 7/8"	43 7/16"	24 1/8"
	60" (59.68")	18 7/16"	44 7/8"	49 7/16"	24 1/8"
	66" (65.68")	18 7/16"	50 7/8"	55 7/16"	24 1/8"
	72" (71.68")	18 7/16"	56 7/8"	61 7/16"	24 1/8"
	78" (77.68")	18 7/16"	62 7/8"	67 7/16"	24 1/8"
	84" (83.68")	18 7/16"	68 7/8"	73 7/16"	24 1/8"
	90" (89.68")	18 7/16"	74 7/8"	79 7/16"	24 1/8"
96" (95.68")	18 7/16"	80 7/8"	85 7/16"	24 1/8"	

Dimensions

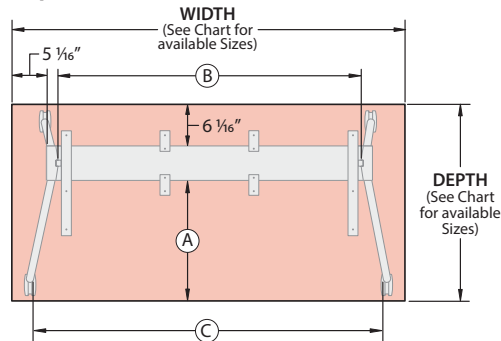

Front View

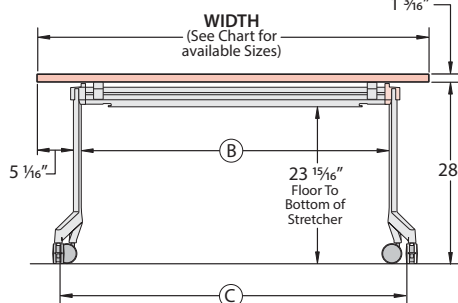

Side View

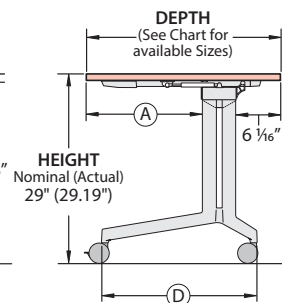

Note

A panel mounted worksurface and an adjacent freestanding table do not have the same level of adjustment to horizontally align worktops. Building floors with inherently uneven characteristics may also contribute this planning condition; plan accordingly.

Product Details – Planes Training Tables

Crescent – Flip Top or Non-Flip Top Training Table

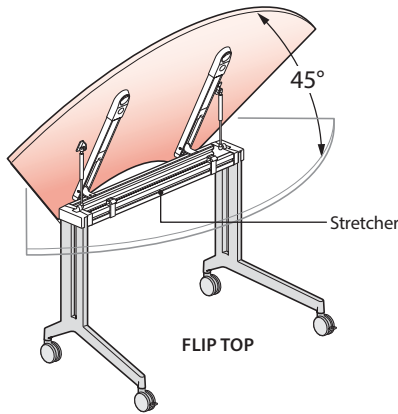
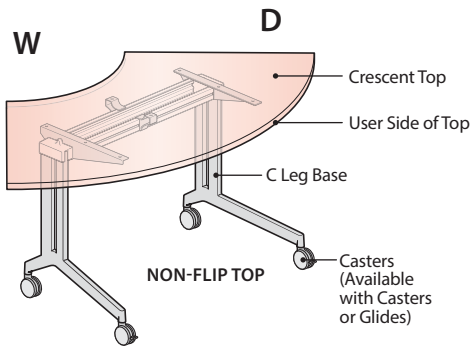

Component Materials/Finishes

COMPONENT NAME		MATERIALS/FINISHES
Crescent Table Top • Flip Top or Non-Flip Top	Laminate Top • Specify surface color and separate edge trim color.	(J) Edgeband • 3mm edgeband on all edges. (F) Knife Edge • Knife Edge on user edge only 3mm edgeband on sides and back.
	Wood Top • Specify wood finish color for surface and edgeband.	(K) Wood Edgeband • 3mm edgeband on all edges. (U) Wood Knife Edge • Knife Edge on user edge only 3mm edgeband on sides and back.
C Leg Base, Stretcher, Brackets and Support Arms	(A) Painted Aluminum • C Leg, stretcher, brackets and support arms are painted and require a trim color specification.	
	(B) Polished Aluminum • C Leg base and glide stem are polished aluminum. • Stretcher, brackets and support arms are painted and require a trim color specification.	
Casters (Optional)		Black hub with black tread
		Fog hub with graphite tread
		Light platinum hub with graphite tread
Glides (Optional)	Glide Disc Base	Available in black, fog, or light platinum.
	Glide Stem	Painted or polished to match base.

Available Sizes

TABLETOP (Non-Flip and Flip)	
Depth Nominal (Actual)	Width Nominal (Actual)
30" (29.68")	60" (59.68")

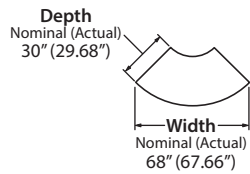

Dimensions Top View

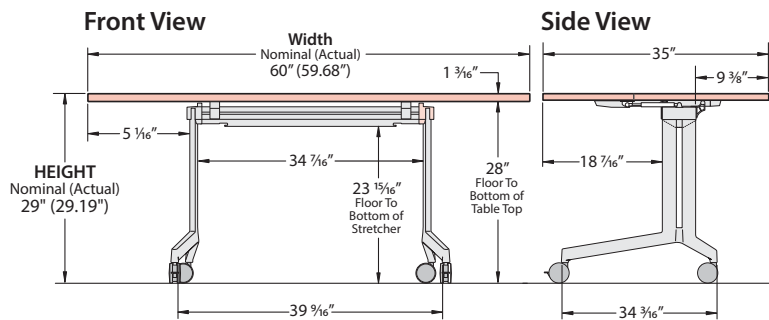
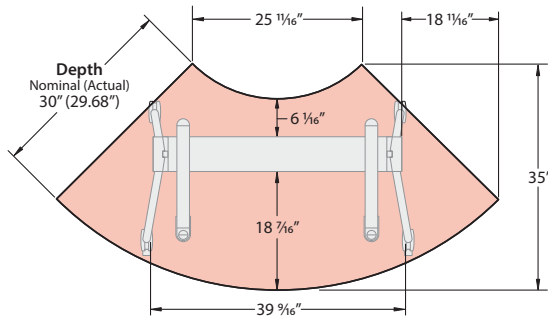

Note A panel mounted worksurface and an adjacent freestanding table do not have the same level of adjustment to horizontally align worktops. Building floors with inherently uneven characteristics may also contribute this planning condition; plan accordingly.

Product Details – Planes Training Tables

Trapezoid – Flip Top or Non-Flip Top Training Table

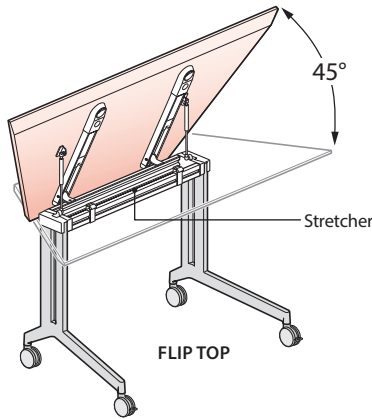
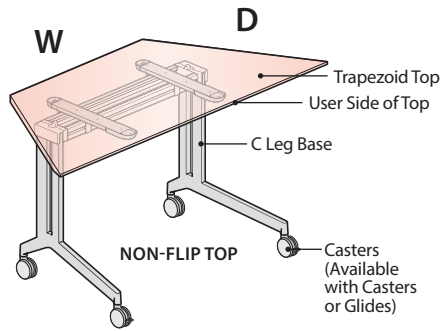

Available Sizes

TABLETOP (Non-Flip and Flip)	
Depth Nominal (Actual)	Width Nominal (Actual)
30" (29.68")	60" (59.68")

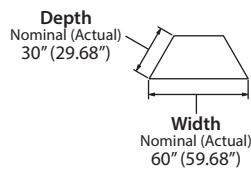

Component Materials/Finishes

COMPONENT NAME	MATERIALS/FINISHES	
Trapezoid Table Top • Flip Top or Non-Flip Top	Laminate Top • Specify surface color and separate edge trim color.	(J) Edgeband • 3mm edgeband on all edges. (F) Knife Edge • Knife Edge on user edge only 3mm edgeband on sides and back.
	Wood Top • Specify wood finish color for surface and edgeband.	(K) Wood Edgeband • 3mm edgeband on all edges. (U) Wood Knife Edge • Knife Edge on user edge only 3mm edgeband on sides and back.
C Leg Base, Stretcher, Brackets and Support Arms	(A) Painted Aluminum • C Leg, stretcher, brackets and support arms are painted and require a trim color specification.	
	(B) Polished Aluminum • C Leg base and glide stem are polished aluminum. • Stretcher, brackets and support arms are painted and require a trim color specification.	
Casters (Optional)		Black hub with black tread
		Fog hub with graphite tread
		Light platinum hub with graphite tread
Glides (Optional)	Glide Disc Base	Available in black, fog, or light platinum.
	Glide Stem	Painted or polished to match base.

Dimensions Top View

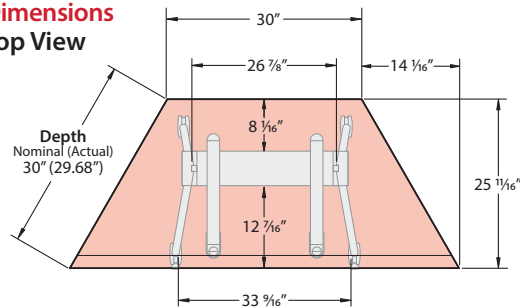

Front View

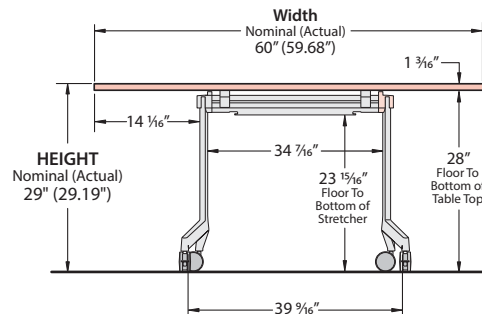

Side View

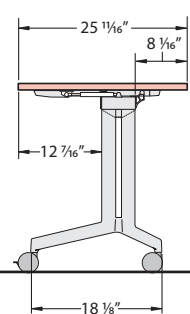

Note A panel mounted worksurface and an adjacent freestanding table do not have the same level of adjustment to horizontally align worktops. Building floors with inherently uneven characteristics may also contribute this planning condition; plan accordingly.

Product Details – Planes Training Tables

Polygon – Flip Top or Non-Flip Top Training Table

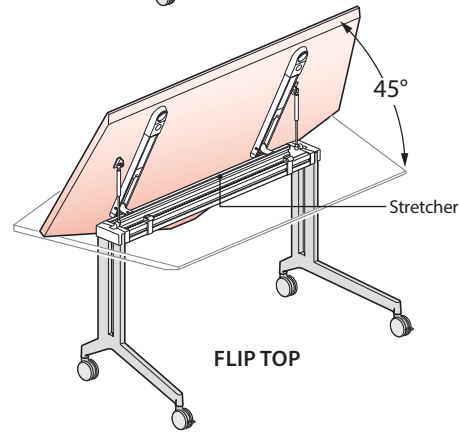
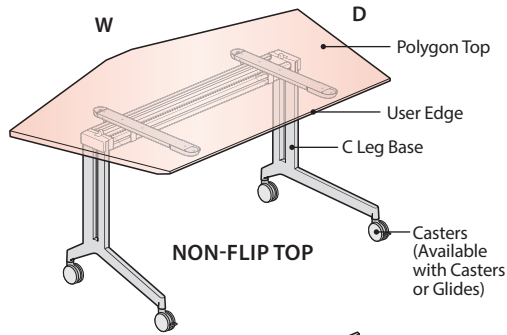

Available Sizes

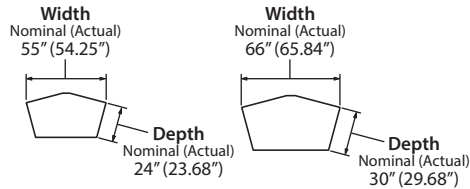

Component Materials/Finishes

COMPONENT NAME		MATERIALS/FINISHES
Polygon Table Top	• Flip Top or Non-Flip Top	(J) Edgeband • 3mm edgeband on all edges.
		(F) Knife Edge • Knife Edge on user edge only 3mm edgeband on sides and back.
C Leg Base, Stretcher, Brackets and Support Arms		(K) Wood Edgeband • 3mm edgeband on all edges.
		(U) Wood Knife Edge • Knife Edge on user edge only 3mm edgeband on sides and back.
Casters (Optional)		(A) Painted Aluminum • C Leg, stretcher, brackets and support arms are painted and require a trim color specification.
		(B) Polished Aluminum • C Leg base and glide stem are polished aluminum. • Stretcher, brackets and support arms are painted and require a trim color specification.
		Black hub with black tread
Glides (Optional)	Glide Disc Base Glide Stem	Fog hub with graphite tread
		Light platinum hub with graphite tread
		Available in black, fog, or light platinum.
		Painted or polished to match base.

Dimensions

Top View

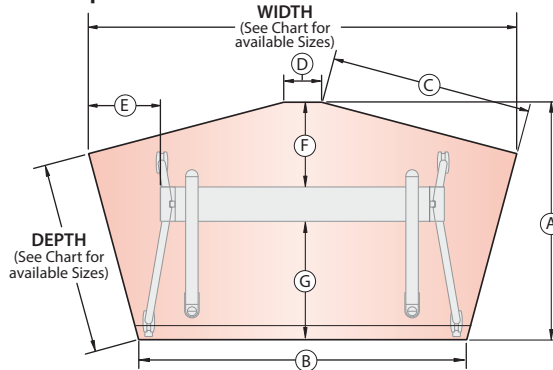

Front View

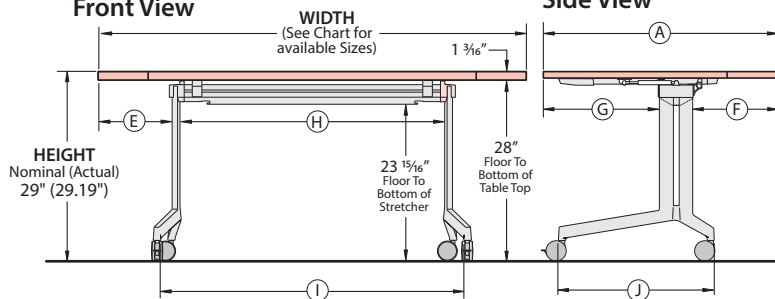

Side View

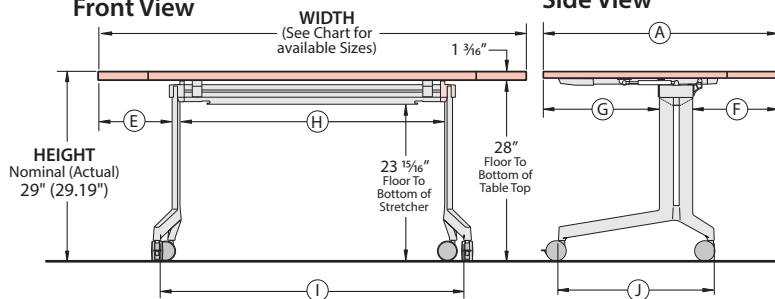

TABLETOP		C-LEG BASE									
Depth Nominal (Actual)	Width Nominal (Actual)	A	B	C	D	E	F	G	H	I	J
24" (23.68")	55" (54.25")	29 3/16"	42"	24 1/2"	8 3/8"	8 5/16"	9 9/16"	14 7/16"	32 7/8"	37 7/16"	18 1/8"
30" (29.68")	66" (65.84")	36 1/2"	50 1/2"	30 1/2"	11 3/16"	11 1/8"	10 7/8"	20 7/16"	38 7/8"	45 9/16"	24 1/8"

Note A panel mounted worksurface and an adjacent freestanding table do not have the same level of adjustment to horizontally align worktops. Building floors with inherently uneven characteristics may also contribute this planning condition; plan accordingly.

Product Details – Planes Training Tables

Pie Connector

- Includes 1 3/16" thick top and Two sets of ganging mechanisms required for support.

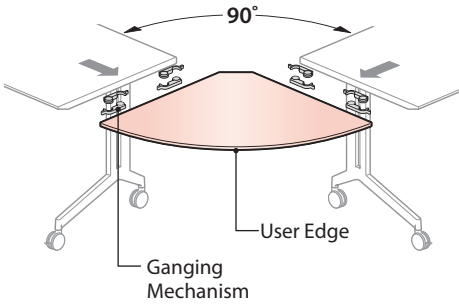

Component Materials/Finishes

COMPONENT NAME	MATERIALS/FINISHES	
Pie Connector Top • Flip Top or Non-Flip Top	Laminate Top • Specify surface color and separate edge trim color.	(J) Edgeband • 3mm edgeband on all edges. (F) Knife Edge • Knife Edge on user edge only 3mm edgeband on sides and back.
	Wood Top • Specify wood finish color for surface and edgeband.	(K) Wood Edgeband • 3mm edgeband on all edges. (U) Wood Knife Edge • Knife Edge on user edge only 3mm edgeband on sides and back.
Ganging Mechanism	Black plastic	

Available Sizes and Dimensions

90° Pie Connector

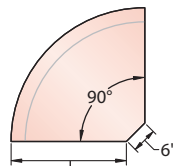

Depth
Nominal (Actual)
20" (19.68")

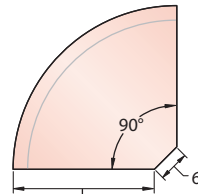

Depth
Nominal (Actual)
24" (23.68")

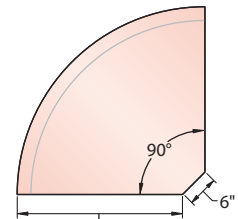

Depth
Nominal (Actual)
30" (29.68")

45° Pie Connector

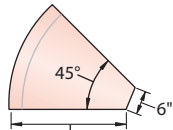

Depth
Nominal (Actual)
20" (19.68")

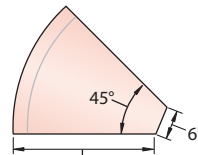

Depth
Nominal (Actual)
24" (23.68")

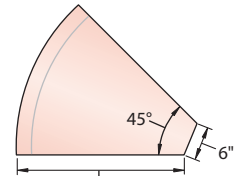

Depth
Nominal (Actual)
30" (29.68")

30° Pie Connector

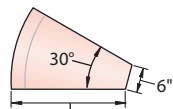

Depth
Nominal (Actual)
20" (19.68")

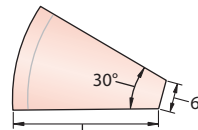

Depth
Nominal (Actual)
24" (23.68")

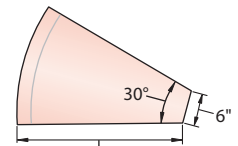

Depth
Nominal (Actual)
30" (29.68")

15° Pie Connector

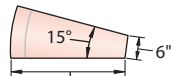

Depth
Nominal (Actual)
20" (19.68")

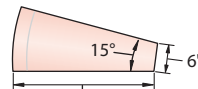

Depth
Nominal (Actual)
24" (23.68")

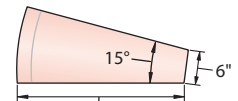

Depth
Nominal (Actual)
30" (29.68")

Product Details – Planes Training Tables

Modesty Panels

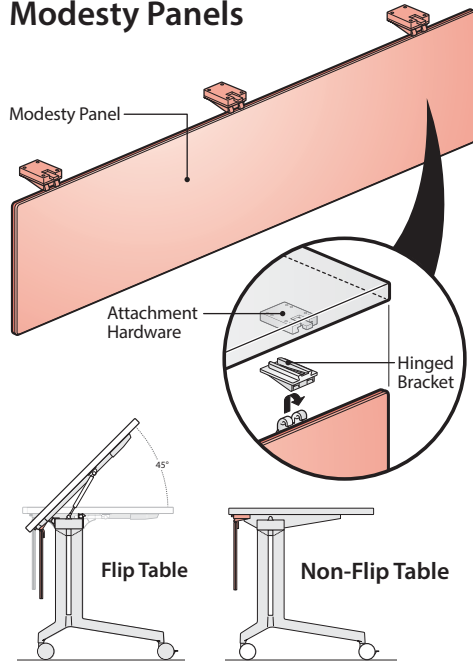

- The modesty panel features a hinged bracket for ease of nesting and storing tables without removing the Modesty Panel.
- Hinged bracket allows Modesty Panel to be easily removed without tools.

Dimensions

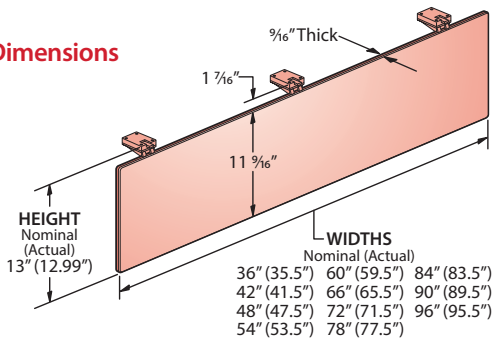

Wood Grain Direction

Natural, Quarter Cut or Rift Cut Veneer

- Wood grain is applied vertically.

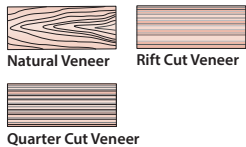

Double Cut Veneer

- Wood grain is applied horizontally.



Wood Grain Laminate

- 36"-60" Wide—Vertical wood grain
- 66"-96" Wide—Horizontal wood grain

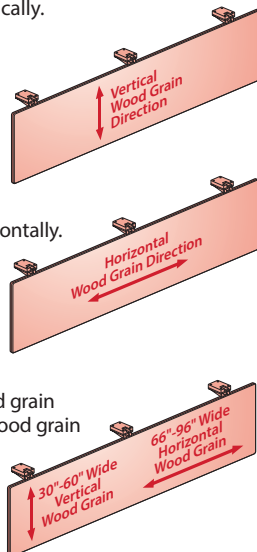

Component Materials/Finishes

COMPONENT NAME	MATERIALS/FINISHES	
Modesty Panel	Fabric	Specify fabric color.
	Laminate	Specify laminate trim color for the surface, and a separate specification for the edgeband.
	Wood	Specify wood finish for surface and edgeband color.
Hinged Bracket and Attachment Hardware	Black plastic	

Full Width Modesty Panel – Option (F)

- (F) Full-width modesty panel will be width of the rectangular table and are not for use with tables that are connected with 2-Circuit Modular Power or Quick Connect electrical components.

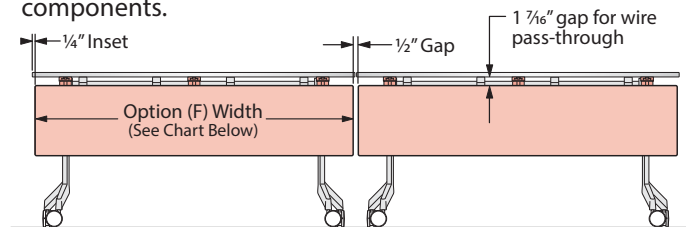

Powered Table Modesty Panel – Option (P)

- Code Compliance requires a 6" gap between modesty panels for all powered Planes Training Tables using Quick Connect or 2-Circuit Power.

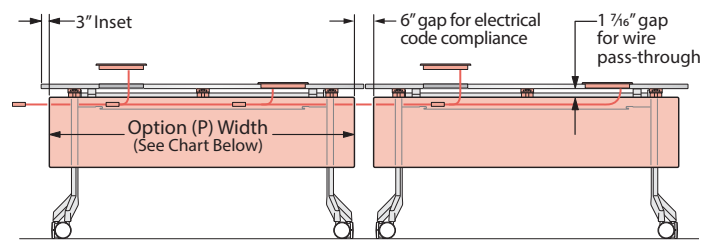

Training Table Specification Matrix

TOP SHAPE	TRAINING TABLES WIDTHS	MODESTY PANEL WIDTHS	
	WIDTH Nominal (Actual)	Option (F) Full Width Modesty Panel Width	Option (P) Powered Table Modesty Panel Width
Rectangular	36" (35.68")	35.5" Wide	29.5" Wide
	42" (41.68")	41.5" Wide	35.5" Wide
	48" (47.68")	47.5" Wide	41.5" Wide
	54" (53.68")	53.5" Wide	47.5" Wide
	60" (59.68")	59.5" Wide	53.5" Wide
	66" (65.68")	65.5" Wide	59.5" Wide
	72" (71.68")	71.5" Wide	65.5" Wide
	78" (77.68")	77.5" Wide	71.5" Wide
	84" (83.68")	83.5" Wide	77.5" Wide
	90" (89.68")	89.5" Wide	83.5" Wide
	96" (95.68")	95.5" Wide	89.5" Wide
Crescent	60" (59.68")	N/A	N/A
Trapezoid	60" (59.68")	N/A	29.5" Wide
Polygon	55" (54.25")	N/A	41.5" Wide
	66" (65.84")	53.5"	47.5" Wide

Product Details – Planes Training Tables

Flip Top Table Heights and Nesting

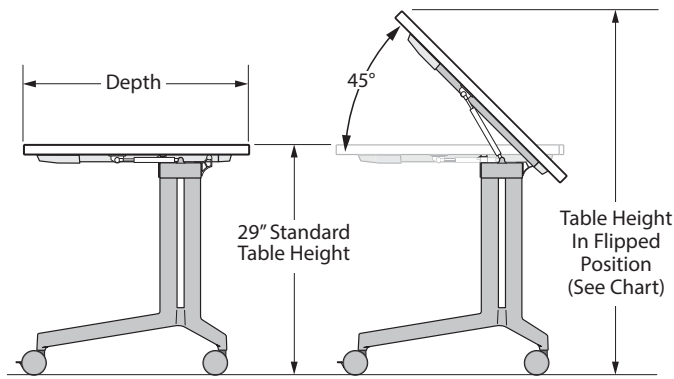

TABLE TOP SHAPE	FLIPPED HEIGHT (24" Deep Table)	FLIPPED HEIGHT (30" Deep Table)
Rectangle	41 7/8"	41 1/8"
Crescent	N/A	47 1/2"
Trapezoid	N/A	41 13/16"
Polygon	43 1/4"	47 7/16"



- Training tables always have two C-legs at the base.
- Standard table height is 29" nominal with 28" knee clearance.
- Knee clearance under stretcher is 23.98"

Nesting Training Tables in the Flipped Position

Calculating overall WIDTH of nested tables:

- **Staggered Table Nesting:** Width of table 60" plus 3.25" for each additional table.
- **Zigzag Table Nesting:** Width of table plus 3.25" for 2nd table.

Calculating overall DEPTH of nested tables:

- **Staggered or Zigzag Table Nesting:** Overall depth of table in flipped position (A) plus 3.25" for each additional table.

Example: (3) 60" wide x 24" deep nested tables

Staggered Table Nesting Example:

Total Width: 60" (Table 1 Width) + 3.25" (for Table 2) + 3.25" (for Table 3) = **66.50"**
Total Depth: 24" (Table 1 Depth) + 12.19" (for Table 2) + 12.19" (for Table 3) = **48.37"**

Zigzag Table Nesting Example:

Total Width: 60" (Table 1 Width) + 3.25" (for 2nd Table) = **63.25"**
Total Depth: 24" (Table 1 Depth) + 12.19" (for Table 2) + 12.19" (for Table 3) = **48.37"**



3.25" (width) and 12.19" (depth) are constant dimensions for nesting all table shapes, widths and depths

Training Table Depths in the Flipped Position

TABLE TOP SHAPE	TOP DEPTHS	(A) Overall Depth of Table in the Flipped Position	(B) Depth of C Leg Base
Rectangle	24" Deep	21 1/2"	21 1/4"
	30" Deep	27 1/2"	27 1/4"
Crescent	30" Deep	28 1/4"	27 1/4"
Trapezoid	30" Deep	28 1/4"	27 1/4"
Polygon	24" Deep	21 1/2"	21 1/4"
	30" Deep	27 1/2"	27 1/4"



Example based upon nesting tables of same depths and widths.

Top View – Staggered Table Nesting

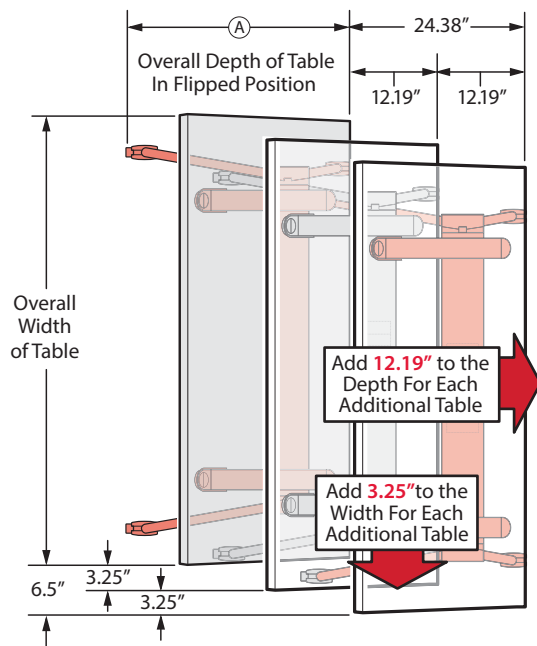

Top View – Zigzag Table Nesting

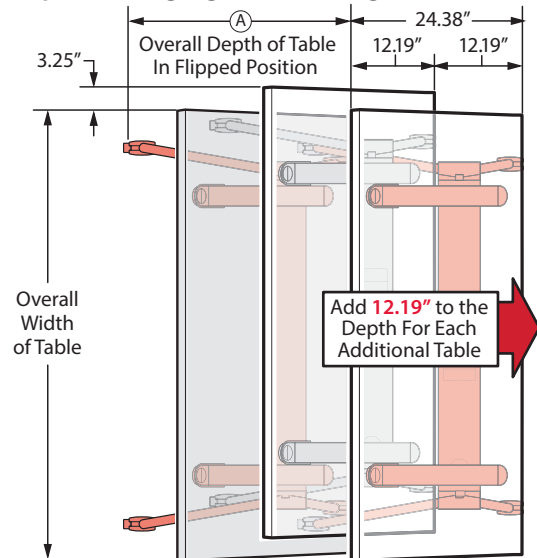

Side View

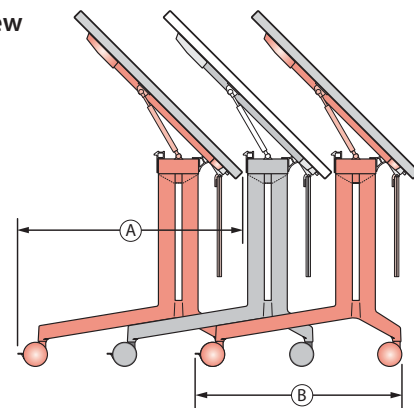

Product Details – Planes Training Tables

Edge Options – 3mm Edgeband

Laminate Edgeband (Option J)

Wood Edgeband (Option K)

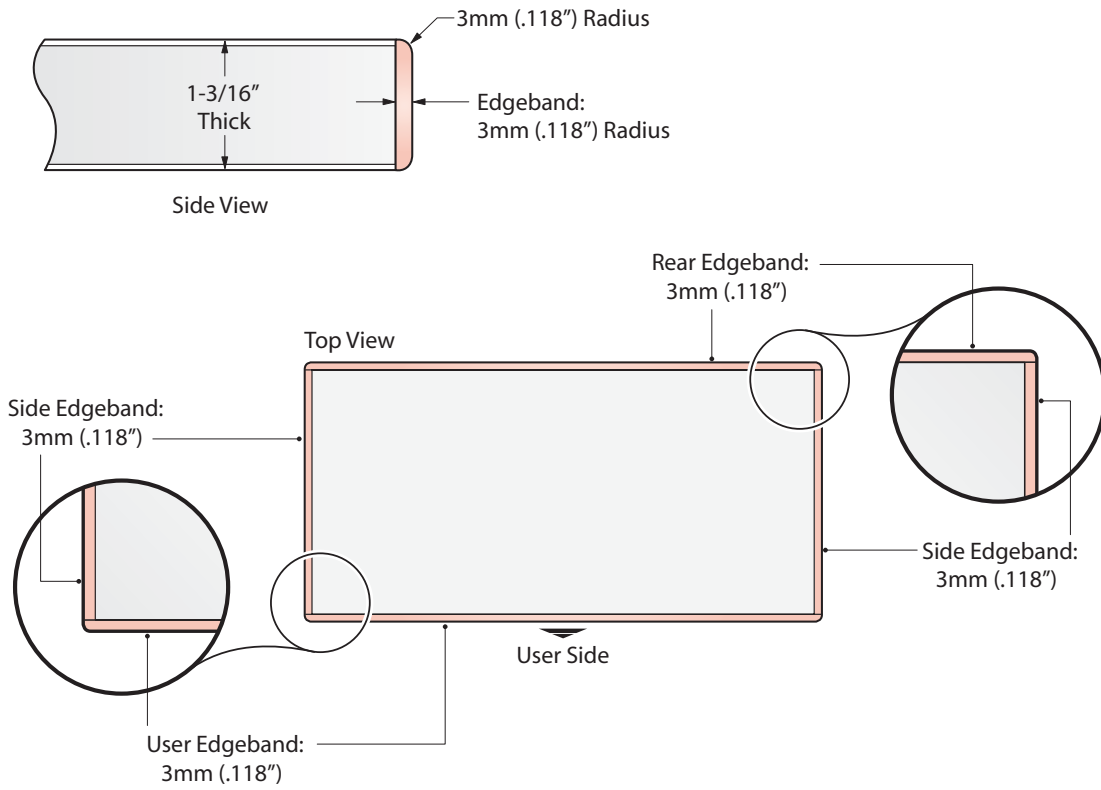

Product Details – Planes Training Tables – Edge Options

Edge Options – Knife Edge

Laminate Edgeband (Option F)

Wood Edgeband (Option U)

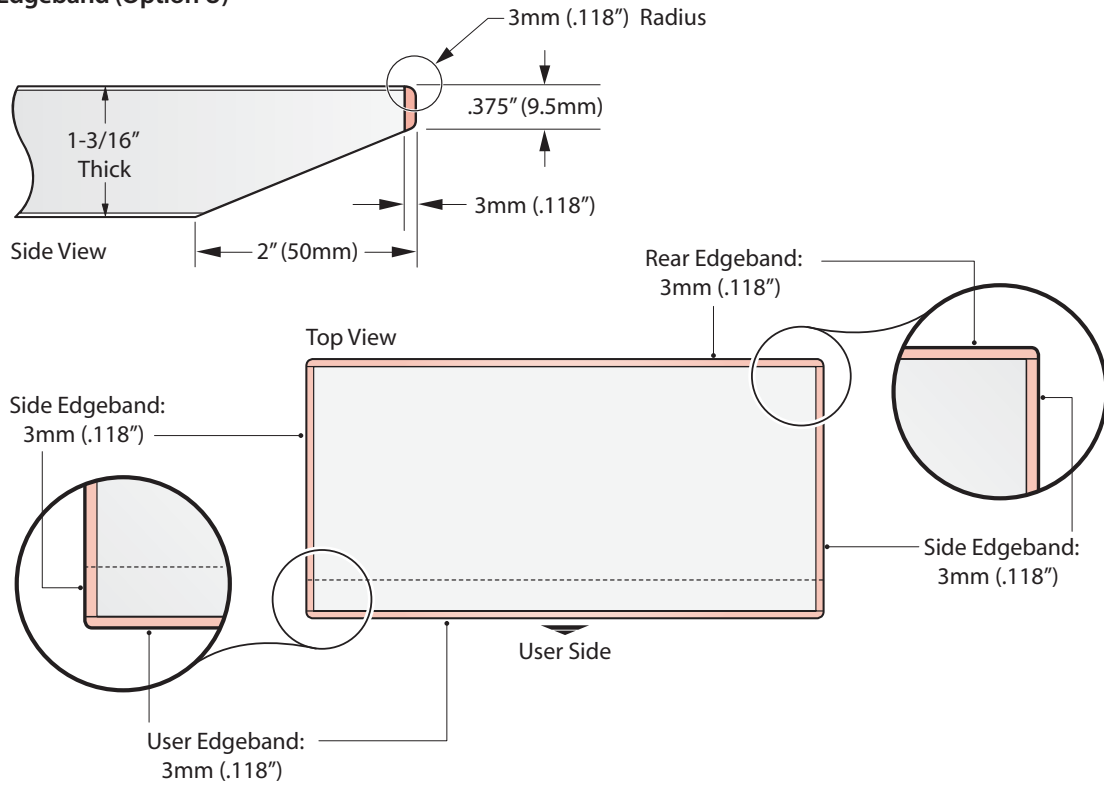

Product Details – Planes Training Tables

Flip Top Unit Centered Back Cutout Locations

- The centered back cutout option can be specified for all training table shapes.
- The cutout is centered on the table top.
- The distance from the back edge of the cutout to the back edge of the table top varies depending on the table shape.
- Locations are for cutout (not bezel of flip top unit).
- Cut-out sizes will vary to match separately specified Flip Top Units (2, 4 or 6 Port cutouts sizes available).

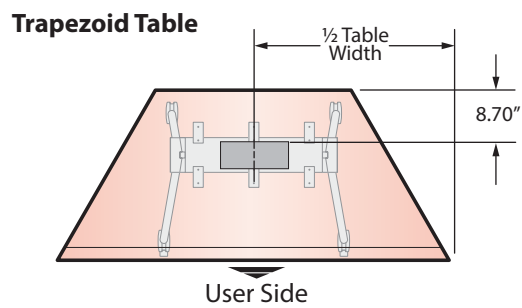
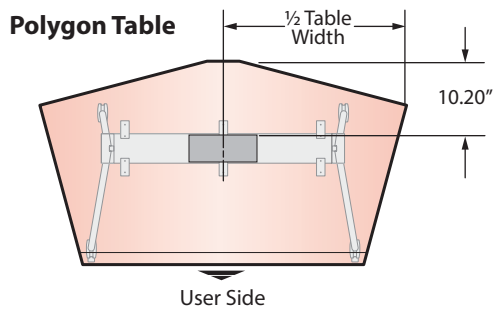
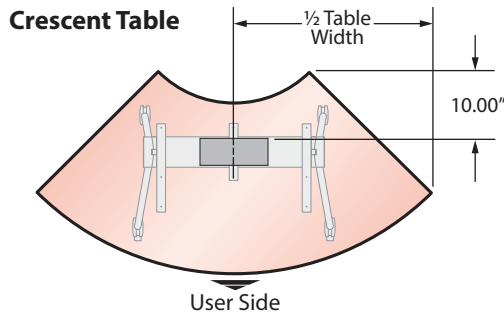
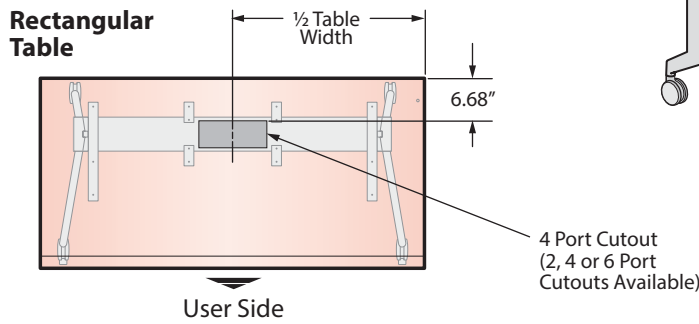
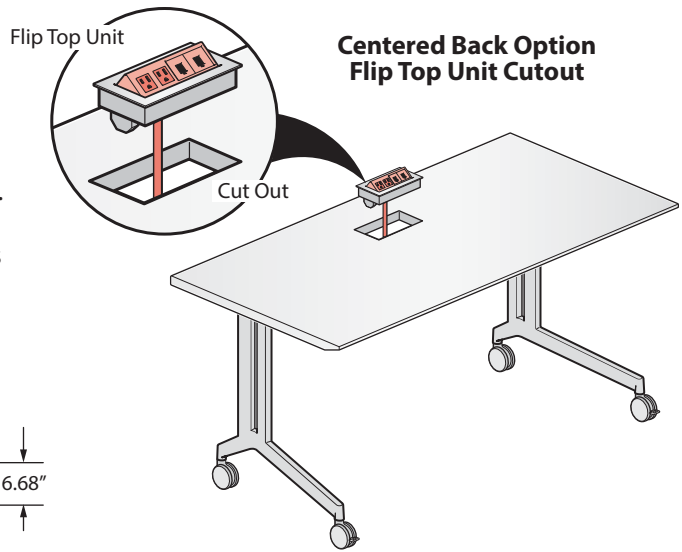

Cutout / Port Options:

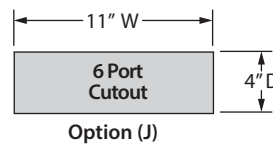
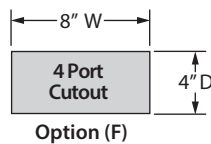
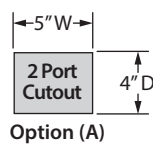

Product Details – Planes Training Tables

Flip Top Unit Left and Right Back Cutout Locations

- The left and right back cutout option consists of two cutouts per table, one left hand and one right hand, this option may be specified for 60", 66", 72", 78", 84", 90" and 96" Rectangular Tables only.
- Centerline of the cutouts will be $\frac{3}{8}$ and $\frac{5}{8}$ of the table width from the side edge of the table.
- Cutouts will be located 6.68" from the back edge of the table to the back edge of the cutouts.
- Locations are for cutout (not bezel of flip top unit).
- Cut-out sizes will vary to match separately specified Flip Top Unit (2, 4 or 6 Port cutouts sizes available).

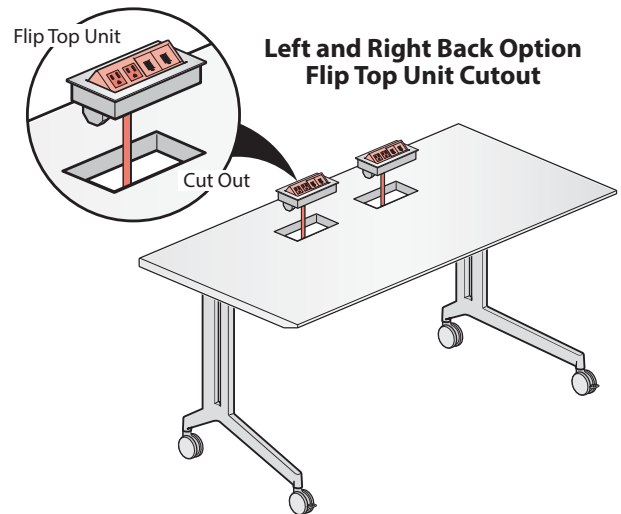

60"W Rectangular Table

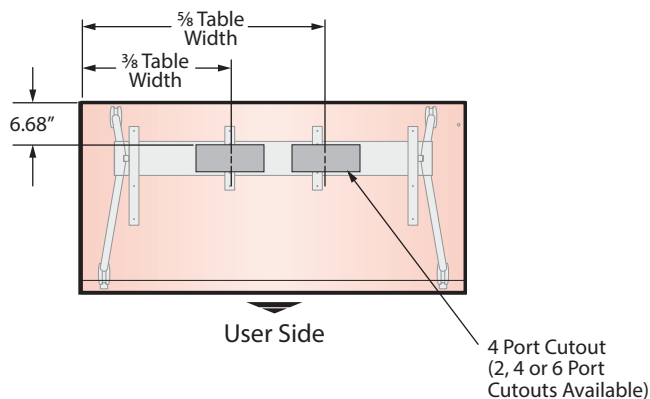

96"W Rectangular Table

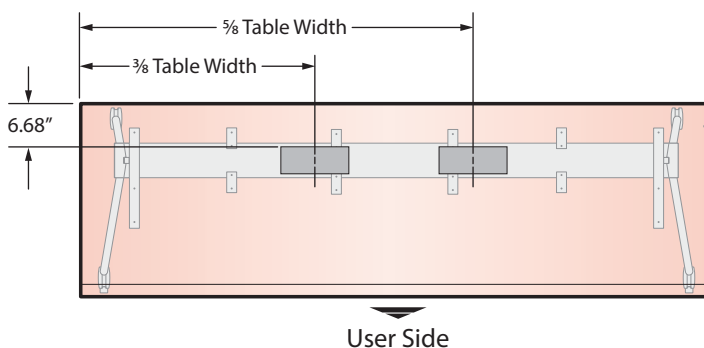

Cutout / Port Options:

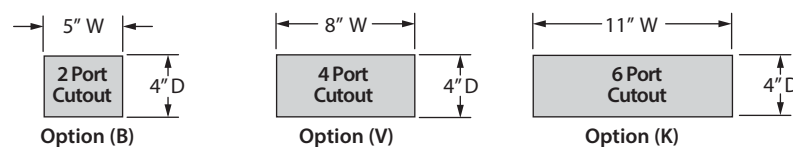

Note • Left / right back option is not available for 36"W-54"W Rectangle Tables, Trapezoid Tables, Polygon Tables and Crescent Tables.

• Spacing for left / right back option is $\frac{3}{8}$ and $\frac{5}{8}$ of the table width to the centerline of the cutout. Cut out sizes will vary.

Product Details – Planes Training Tables

Electrical Components – Flip Top Units

- Training Tables are available with optional cutouts for housing separately specified Single-Sided Flip Top Units.
- Specify Flip Top Unit to match cutout configuration, cutouts are available in 2, 4 or 6 port configurations.
- Flip Top Units may be specified with corded, hardwired or Quick Connect Power connections.
- To provide distribution of power between tables and to facilitate frequent room reconfigurations, Training Tables may be specified with Quick Connect Power or 2-Circuit modular power components.

Corded Flip Top Unit

- Includes 6' or 12' long, 15 amp black cord with plug, singled sided units may be specified with 2, 4 or 6 ports.
- Designed for use with building receptacles or with 2-Circuit Modular Power Kits.
- Corded flip top units with four receptacles or more utilize a fused plug that may block adjacent building receptacle Port.

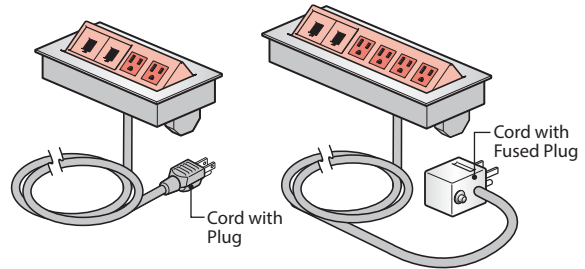

Hardwired Flip Top Unit

- Includes 6' or 12' flexible metal conduit feed with wires for hardwire connection, singled sided units may be specified with 2, 4 or 6 ports.
- Must be hardwired to building power.

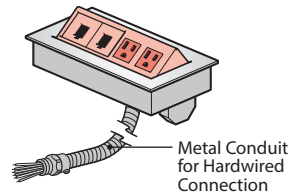

Quick Connect Power – Flip Top Unit

- Includes a 60" cord with two Quick Connect modular connectors, may be specified with 2, 4 or 6 ports.
- Only for use with Planes Training Tables.
- **Only for use with other Quick Connect Power components.**

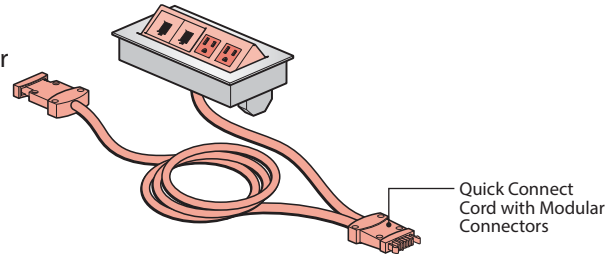

Flip Top Unit: Bezel / Cutout Dimensions

2 Port Flip Top Unit

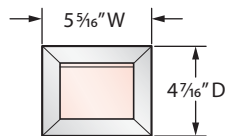

4 Port Flip Top Unit

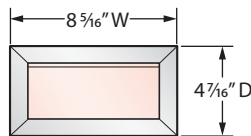

6 Port Flip Top Unit

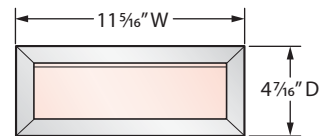

2 Port Cutout Option (A or B)

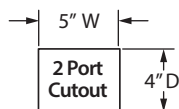

4 Port Cutout Option (F or V)

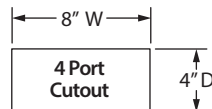

6 Port Cutout Option (J or K)

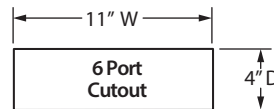

- Flip Top Unit is field installed into a factory cut opening. Specify the number of cutouts needed per table top when ordering the table.
- Corded Flip Top Unit applications should be reviewed by local authorities (electrical inspector) prior to ordering this product.
- For use with 120 volt 60 hertz power source only.

Product Details – Planes Training Tables

Electrical Components – Flip Top Units

Flip Top Units

- The Flip Top Unit spring release cover offers two positions, closed and fully open.
- Order Flip Top Units to match Flip Top Unit cutout option specified for each table.
- The Flip Top Unit spring release cover offers two positions; closed or fully open.
- Flip Top Unit: bezel and pop-up portion are proud to table top when installed into a 1 3/16" or 2" thick table top, the Flip Top Unit will extend below the top.

Fully Open Position

- When open the Flip Top Unit projects 1" above the table top.

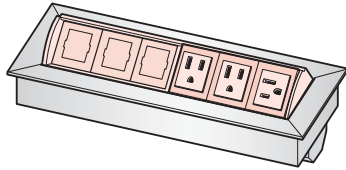

Closed Position

- When closed the flip top bezel is proud to the table top.

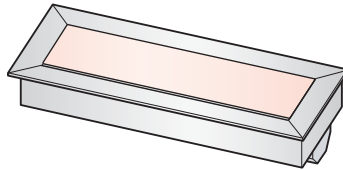

Dimensions – Side View Single Sided

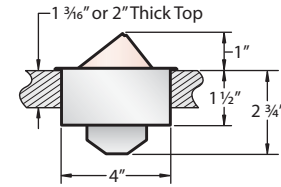

Flip Top Unit Configurations

- The Flip Top Power Module body can be specified with several combinations of Power Ports, USB Charging Ports, Data Ports or Cable Bays. See Price List for available combinations.



Power Ports

- 120V AC 15A (NEMA 5-15R) Configuration



USB Port

- Two USB 2.0 style A charger Ports with 20 Watt capacity



Data Port

- Data Ports include Data Jack Adaptors to mount RJ-45, HDMI Couplers, etc.



Cable Bay

- Provides cavity to stow connector head of HDMI, VGA, or Network Cables when not in use.

Component Materials/Finishes

COMPONENT NAME	MATERIALS/ FINISHES	
Spring Release Cover, Bezel and Housing	Aluminum with a clear or black anodized finish.	
Power Ports, Communication Opening and Data Blank Covers	Plastic in white or black.	
Power Connectors	Cord with Plug	6' or 12' Long standard in black.
	Hardwired	6' or 12' flexible galvanized metal conduit.

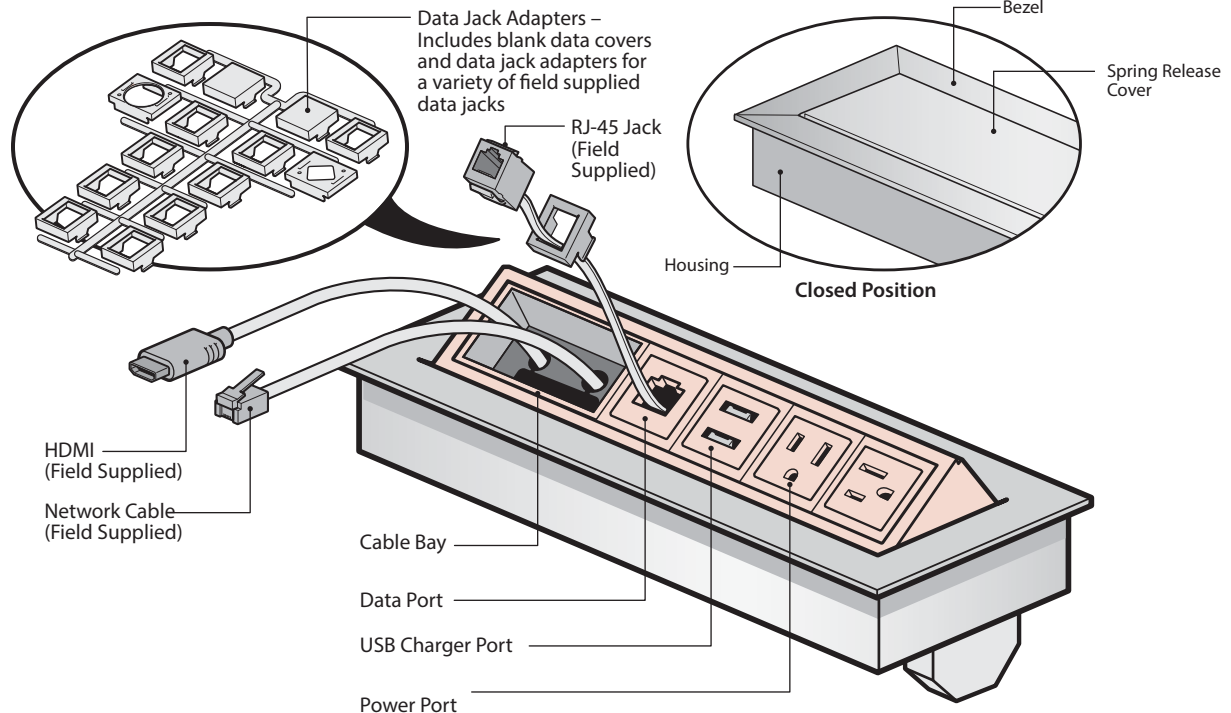

- Note**
- Configuration and quantity of Power Ports, USB Charging Ports, Data Ports, and Cable Bays can not be modified in the field.
 - Cable Bays cannot be retro-fitted with data ports.

Product Details – Planes Training Tables

Electrical Components – Quick Connect Power Flip Top Unit

Quick Connect Power enables power distribution between tables by providing single circuit, corded access to building power. Select this system for frequent room reconfiguration and/or where corded building access is necessary.

- Provides single circuit, 15 Amp power distribution between tables using modular connections.
- Non-sequential: arrange and rearrange quickly and easily
- Starter Box indicator shows green for up to 8 connections (Flip Top Units or Pass Through Connectors), red light indicates too many units
- Connect up to 8 Flip Top Units and/or Table Pass Through Connectors per starter box. Starter Box Indicator shows green for up to 8 connections (Flip Top Units or Pass Through Connectors). Red light indicates too many connections.
- UL recognized - pair with Planes C-Leg Training Tables only.

Quick Connect Power Modular Connection

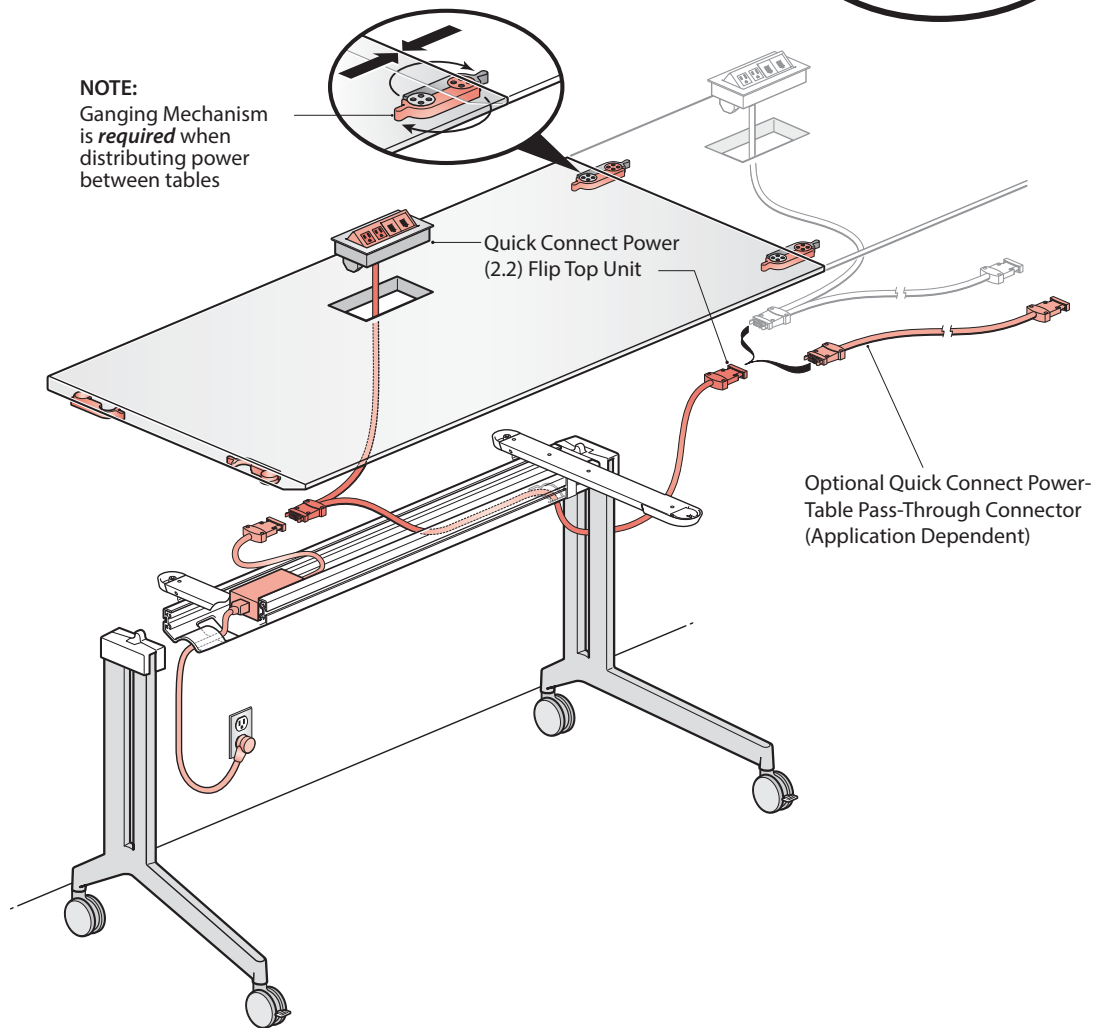
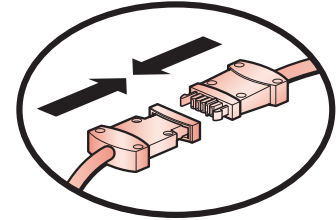

Quick Connect Power — Overview

1. Determine the user's power and data requirements; this will determine the number of cutouts required per table and the power/data configuration for each table cut out.
2. Table top cutouts and the flip top unit which occupies the cut out are separately specified; be certain to specify table cut out and the flip top unit the same size.
3. Table Pass-Through Connectors may be used to route power from table to table. The quantity of connectors is determined by the table width and the table configuration.
4. Separately specified Ganging Mechanisms are required to connect tables together in a table-to-table powered configuration.

Tips To maintain access to the stretcher, the flip top version of Planes Training Tables is recommended

Product Details – Planes Training Tables

Training Tables Electrical – 2-Circuit Power Distribution System

The 2-Circuit Power system enables power distribution between tables by providing two-circuit power with modular, corded or hardwire access to building power. Select this system for occasional room reconfiguration and moderate power demand is planned. Use with separately specified power modules such as the Flip Top Units.

- Two-circuit, 20 amp power distribution between tables
- 10 duplex receptacles per circuit, 20 - 15 amp receptacles per power infeed maximum
- Modular connections between tables
- PVC-free
- UL listed

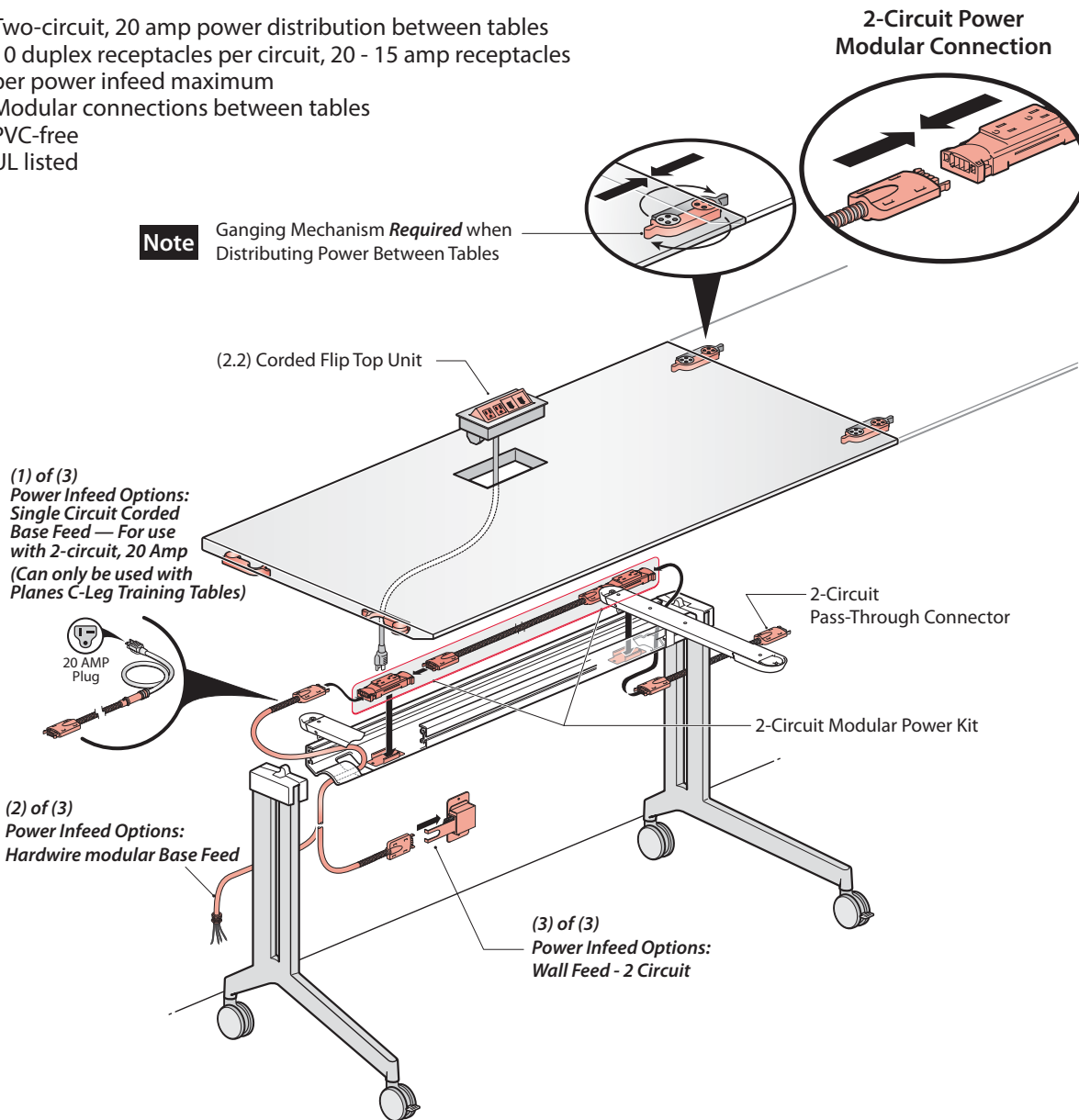

How To Specify 2-Circuit Power

1. Determine the user's power and data requirements; this will determine the number of cutouts required per table and the power/data configuration for each table cut out.
2. Table top cutouts and the flip top unit which occupies the cut out are separately specified; be certain to specify table cut out and the flip top unit the same size.
3. 2-Circuit Modular Power Kits may be used to route power from table to table. 2-Circuit Modular Power Kits based on table size - see price list.
4. Separately specified Ganging Mechanisms are required to connect tables together in a table-to-table powered configuration.

Tips To maintain access to the stretcher, the flip top version of Planes Training tables is required.

Product Details – Planes Training Tables

Wire Management Through the Stretcher

Planes Training Tables feature horizontal wire management for power and data through the stretcher. The flip top table provides the most flexibility for reconfiguration. Whether tables are individually powered or are specified with one of the power distribution systems, Planes Training Tables provide easy wire management.

Quick Connect Power — Wire Management Through the Stretcher

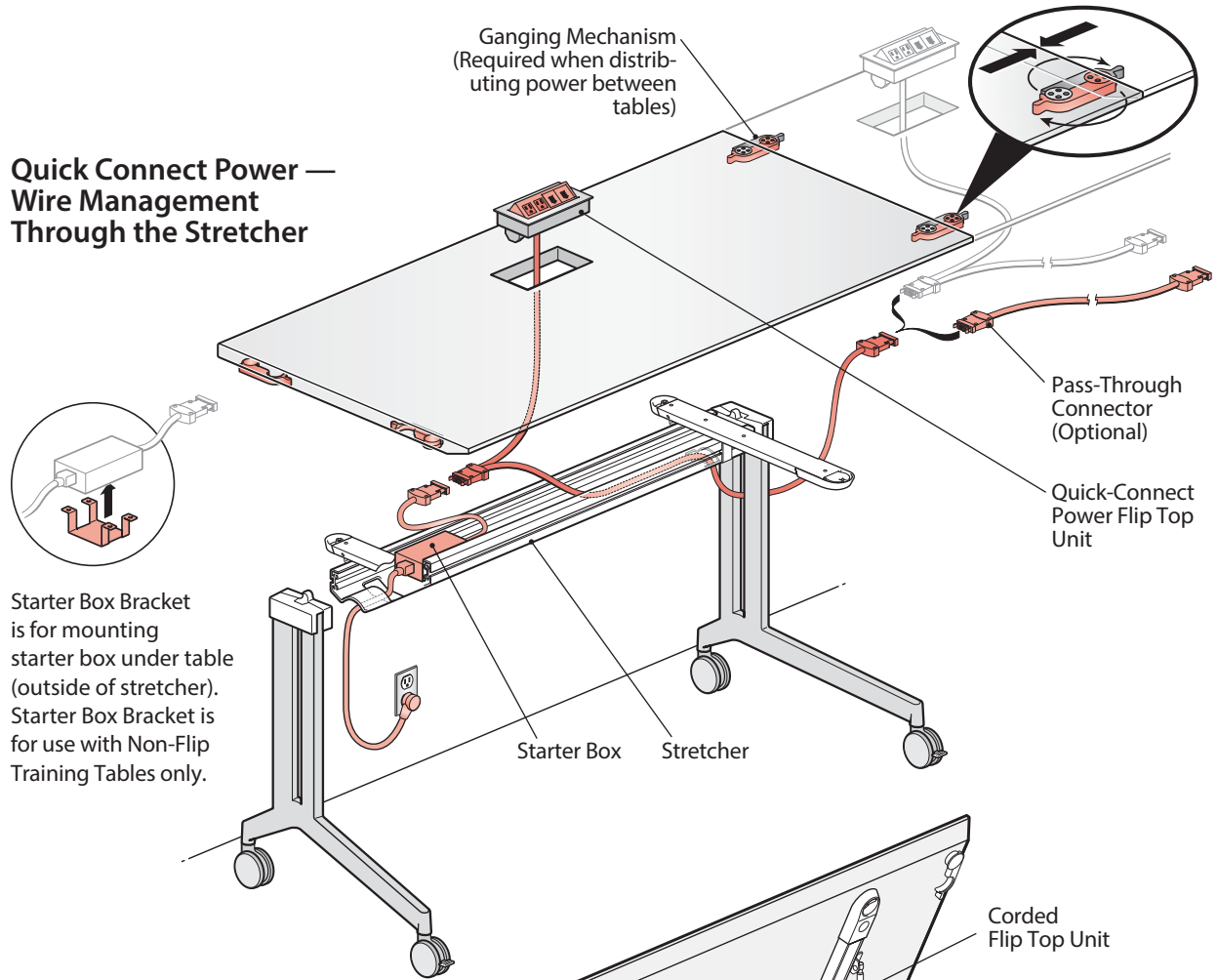

2-Circuit Power — Wire Management Through the Stretcher

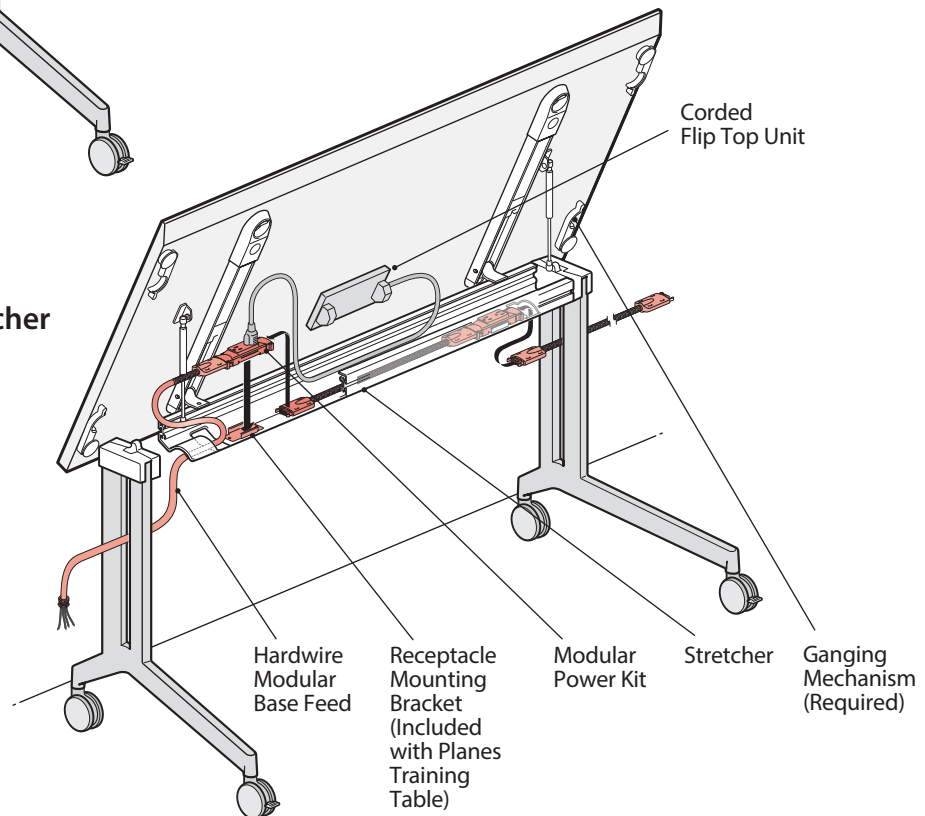

Product Details – Planes Training Tables

Training Tables Electrical – Power Distribution System Planning

Basic Circuit Planning

Quick Connect Power and 2-Circuit Power products are listed for use with multiple power sources. The power sources may be from standard building power or other quality enhanced power systems such as an uninterruptable power supply. Individual power sources must be grounded and connected to the same grounding electrode or a single grounding electrode system. Be sure of ground continuity when using uninterruptable power supplies and isolation transformers.

Circuit Capabilities and Code Restrictions

Quick Connect Power carries a maximum rated load of 15 amps in a single circuit while 2-Circuit Power is rated at 20 amps per each of its two circuits. However, applicable national and local building and electrical codes may further restrict the current usage of this or any other power distribution system. For example, the National Electrical Code (NEC) dictates a load requirement of no more than 80% capacity for continuous load situations (constant use of a circuit for a period of three or more hours). Examples of continuous loading include circuits that supply lighting, computers and printers with power throughout the day. In practice, most circuits are subjected to continuous load.

Planning Guidelines

Haworth recommends planning the initial loading of each circuit below the NEC guideline of 80% of rated amperage. This initial planning limitation permits the user to add or change electrical equipment within the guidelines of local amperage limits. If the system is initially loaded at 80% of rated amperage, the future addition of equipment will be restricted and may force a redesign of the electrical layout.



- Be sure to create an accurate plan illustrating the electrical layout. To ensure safety and compliance, be sure that your plans are pre-approved by the authority having jurisdiction (AHJ).
- All circuit plans should be based on the anticipated equipment load.
- The person or group planning and supervising the installation of electrical components is responsible for complying with all applicable national and local electrical codes.

Product Details – Planes Training Tables

Electrical Components– 2-Circuit Power Applications

Perpendicular Applications

Planning Model:

Rectangular Flip-Top Planes Training Tables perpendicular to each other

- Tables may be the same or different depths
- Tables widths may be the same or different
- Table Widths: 36" – 72"
- Tables Depths: 24" or 30"
- Cutout Option: Centered Back or Left & Right Back; cutout option is dependant on table width

Pass-Through Connector Size:

48" Wide Modular Pass-Through Connector (EAEJ-0048-2)

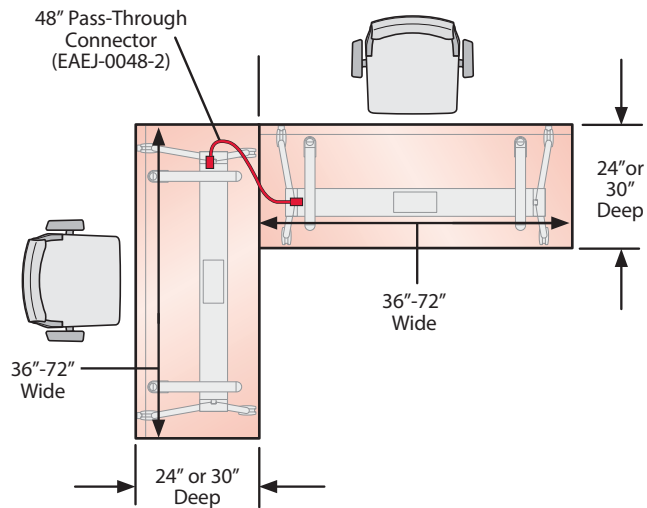

Back to Back Applications

Planning Model:

Rectangular, Trapezoid or Crescent Flip-Top Planes Training Tables positioned back to back

Rectangular Flip-Top Tables:

- Both tables are the same depth
- Tables widths may be different
- Table Widths: 36" – 72"

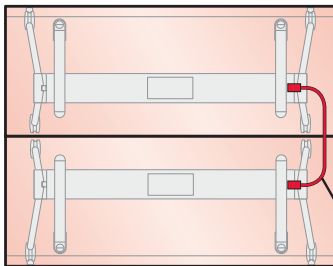

30" Pass-Through Connector (EAEJ-0030-2)

Trapezoid Flip-Top Tables:

- 60" wide x 30" deep, only

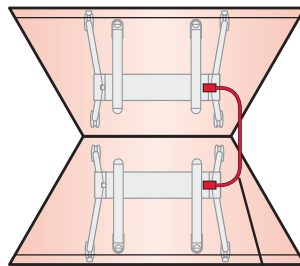

30" Pass-Through Connector (EAEJ-0030-2)

Crescent Flip-Top Tables:

- 68" wide x 30" deep, only

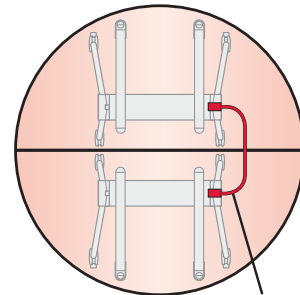

30" Pass-Through Connector (EAEJ-0030-2)

Pass-Through Connector Size:

30" Wide Modular Pass-Through Connector (EAEJ-0030-2)

In-Line Applications

Planning Model:

Rectangular Flip-Top Tables in a straight in-line condition

- Both tables are the same depth
- Tables widths may be the same or different
- Table Widths: 36" – 72"
- Tables Depths: 24" or 30"

Pass-Through Connector Size:

24" Jumper (Included with kit)

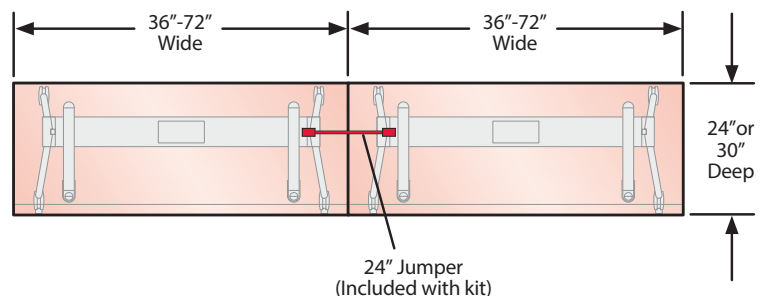

- To maintain utility access within the table stretcher the flip top version of the Planes Training Table is required.
- Separately specified Ganging Mechanisms are required when distributing power between tables.

Product Details – Planes Training Tables

Electrical Components – 2-Circuit Power Applications

Pie Connector / Training Tables – Applications

Planning Model:

- Rectangular Flip-Top Tables with adjoining Pie Connector
- Rectangular Tables and the Pie Connector are the same depth
- Rectangular Table Widths: 36" – 72"
- Rectangular Table & Pie Connector Depths: 24" or 30"
- Pie Connector: 15°, 30°, 45° and 90° angles
- Cutout Option Rectangular Training Table Rectangular Training Table:
 - Centered Back or Left and Right Back;
 - cutout option is dependant on table width.
 - Cutout not available for Pie Connector.

Pie Connector 15°

Pass-Through Connector Size:

36" Wide Modular Pass-Through Connector (EAEJ-0036-2)

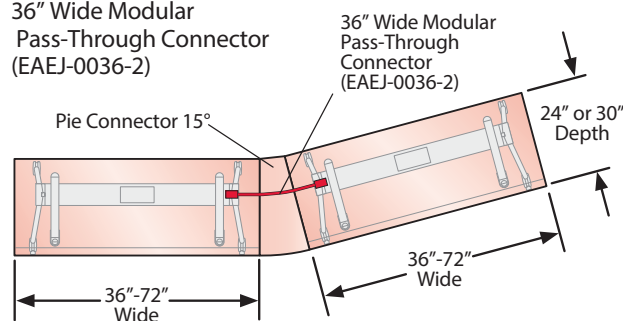

Pie Connector 45°

Pass-Through Connector Size:

42" Wide Modular Pass-Through Connector (EAEJ-0042-2)

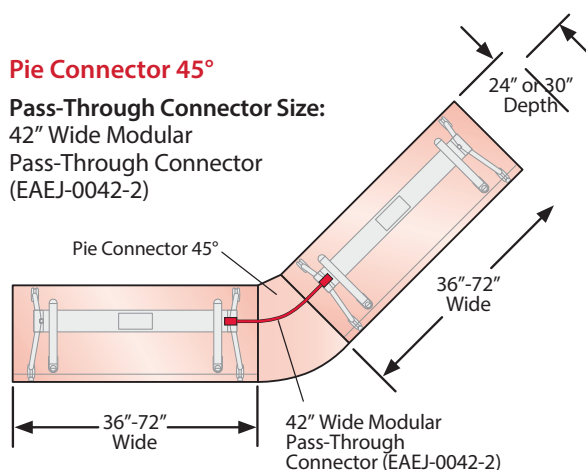

Pie Connector 30°

Pass-Through Connector Size:

42" Wide Modular Pass-Through Connector (EAEJ-0042-2)

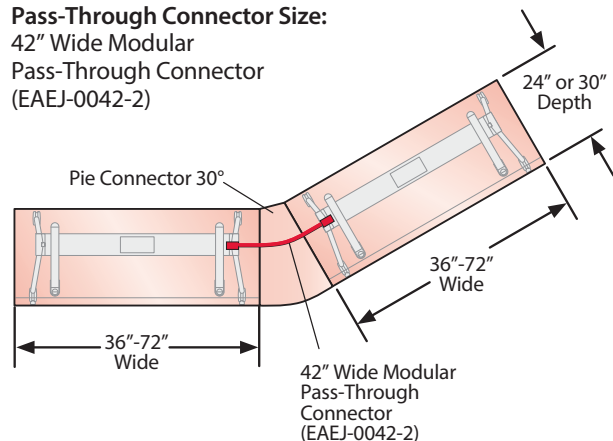

Pie Connector 90°

Pass-Through Connector Size:

54" Wide Modular Pass-Through Connector (EAEJ-0054-2)

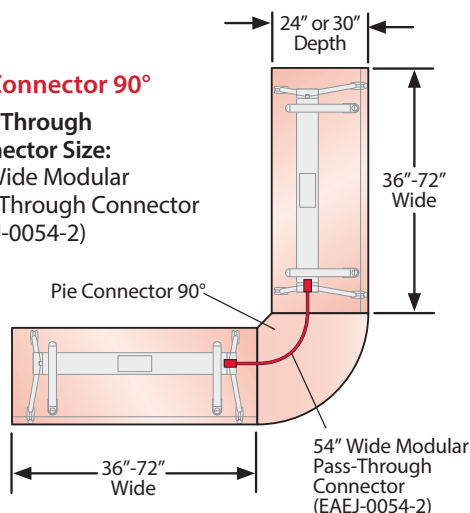

- To maintain utility access within the table stretcher the flip top version of the Planes Training Table is required.
- Ganging Mechanisms are required when distributing power between tables; ganging mechanisms are included with the Pie Connector.

Product Details – Planes Training Tables

Electrical Components – 2-Circuit Power Applications

Crescent Training Tables – Applications

Planning Model:

- Crescent Flip-Top Training Tables only; or Crescent & Rectangular Flip-Top Training Tables
- Crescent & Rectangular Tables are the same depth
- Rectangular Table Widths: 36" – 72"
- Crescent Table: 68" w x 30" d, only
- Crescent Table available with Centered Back Cutout, only
- Rectangular Table - Cutout Option: Centered Back or Left & Right Back; cutout option is dependant on table width.

Pass-Through Connector Size:

24" Jumper Required (Included with kit)

Crescent Training Tables

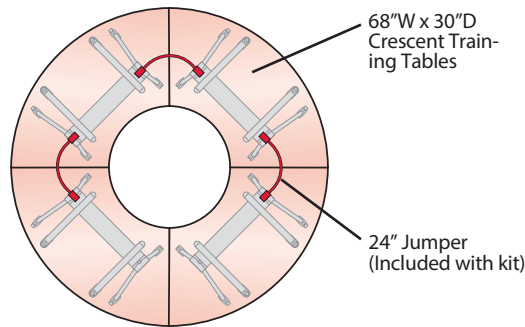

Crescent and Rectangular Training Tables

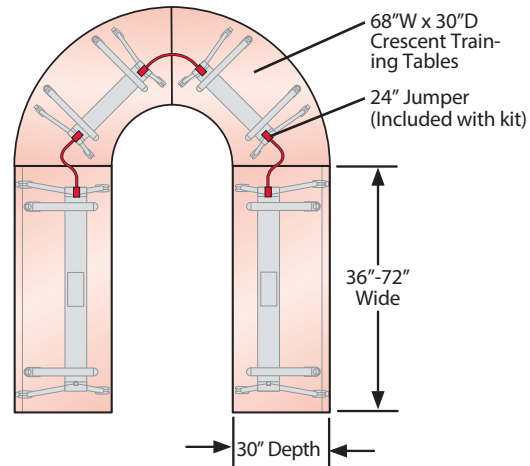

Trapezoid Training Table – Applications

Planning Model:

- Trapezoid Flip-Top Training Tables only; or Trapezoid & Rectangular Flip-Top Training Tables
- Trapezoid & Rectangular Tables are the same depth
- Rectangular Table Widths: 36" – 72"
- Trapezoid Table: 60" w x 30" d, only
- Rectangular Table - Cutout Option: Centered Back or Left & Right Back; cutout option is dependant on table width.

Pass-Through Connector Size:

24" Jumper Required (Included with kit)

Trapezoid Training Tables

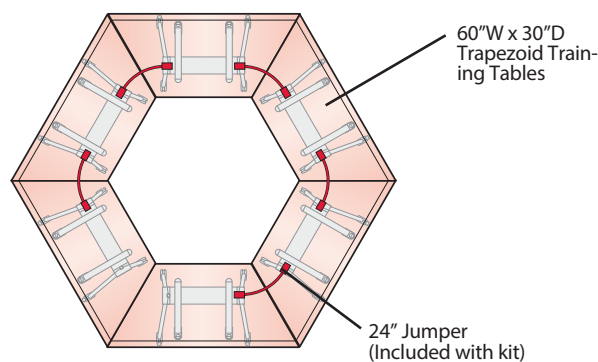

Trapezoid and Rectangular Training Tables

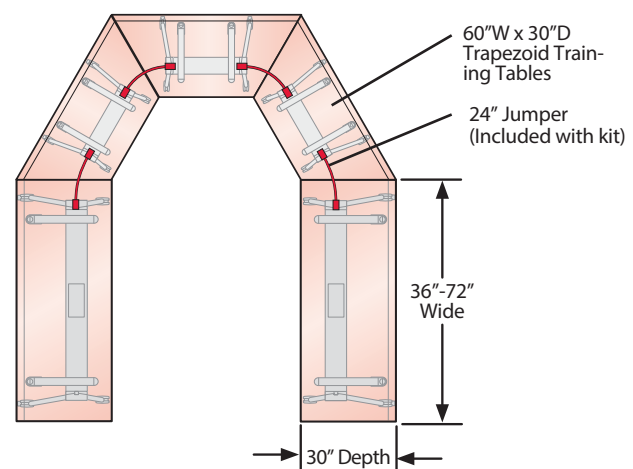

- To maintain utility access within the table stretcher the flip top version of the Planes Training Table is required.
- Separately specified Ganging Mechanisms are required when distributing power between tables.

Product Details – Planes Training Tables

Planes Training Table Applications

Flexible Table Configurations (Non-Powered)

Planes Training tables facilitate dynamic training environments. Here are four layouts using the same set of nine 24" x 60" tables with casters and hinged modesty panel options.

A — Rows

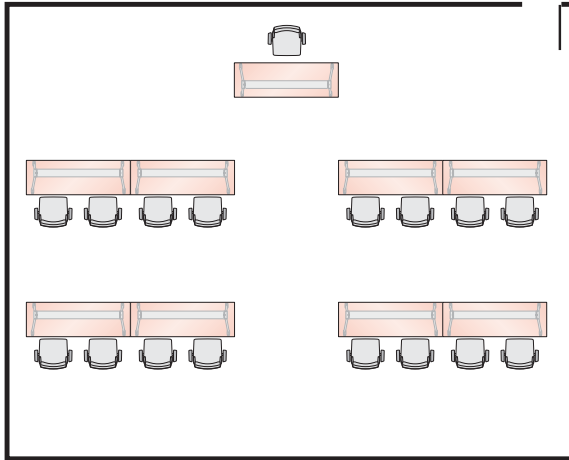

B — U-Shape

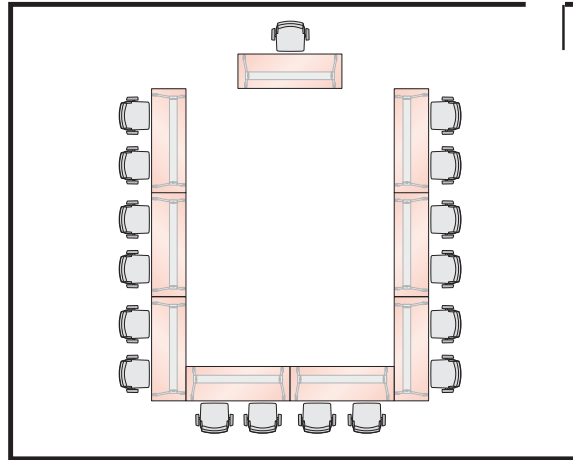

C — Octagon

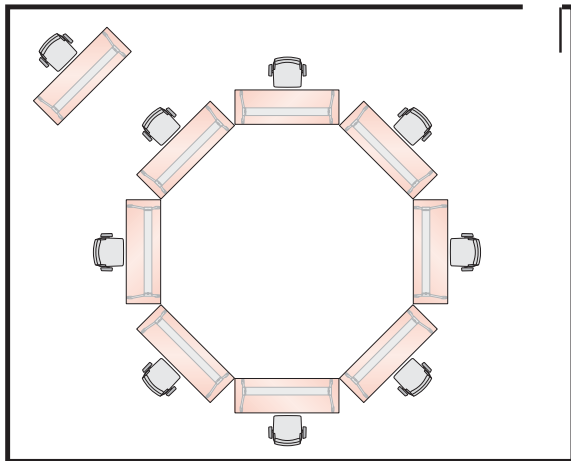

D — Clusters

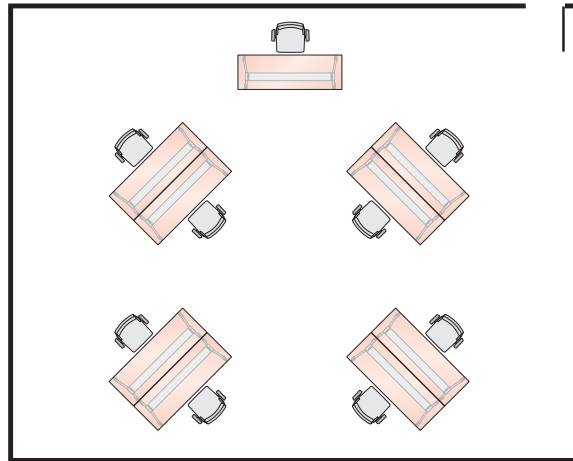

Note

- Power distribution between tables may not be available with some table configurations.
- Some configurations may require additional jumpers and ganging mechanisms for power distribution.

Product Details – Planes Training Tables

Planes Training Table Applications

Theater Style Classroom

- (14) 24" x 60" Rectangle Tables
- (1) 24" x 36" Rectangle Table

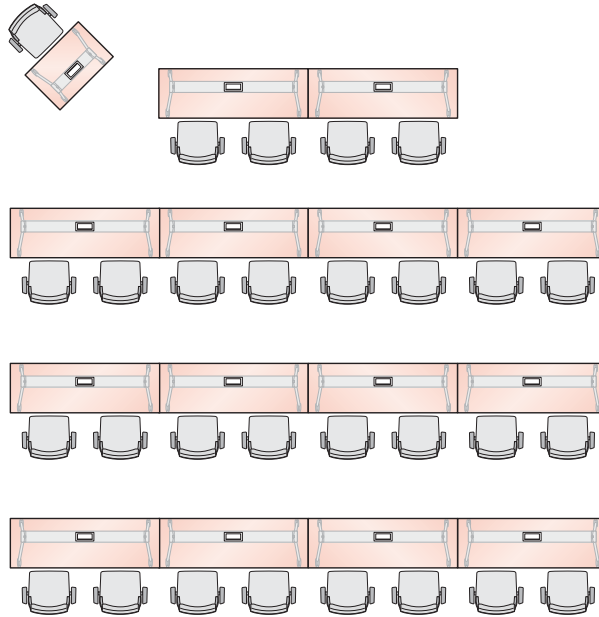

Break-Out Areas

- (6) 30" x 60" Trapezoid Tables

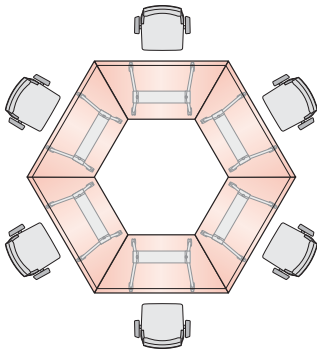

- (4) 30" x 68" Crescent Tables

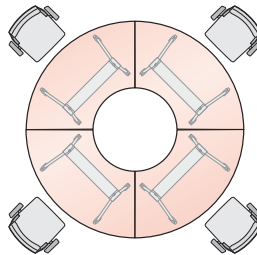

V-Shape

- (1) 24" x 55" Polygon Tables
- (4) 24" x 60" Rectangle Tables

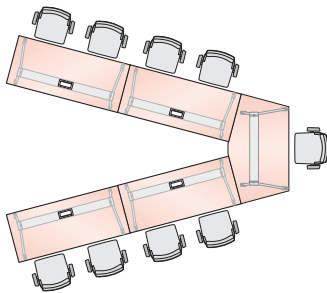

Open Square

- (4) 24" x 60" Rectangle Tables

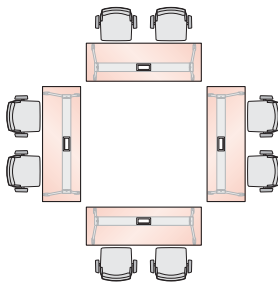

Note • Power distribution between tables may not be available with some table configurations.
• Some configurations may require additional jumpers and ganging mechanisms for power distribution.

Product Details – Planes Carts

Overview

- The Planes Cart Collection is the perfect way to make your meeting area mobile with optional casters.
- The Cart collection can help with all of your media and catering needs.

Wood Grain Direction – Natural Veneer, Quarter Cut Veneer, Rift Cut Veneer and Wood Grain Laminate

Vertical Surfaces – Wood grain direction runs top-to-bottom on door fronts, back panels, side panels and most vertical surfaces.

Horizontal Surfaces – Wood grain direction runs side-to-side on tops, shelves and most horizontal surfaces.

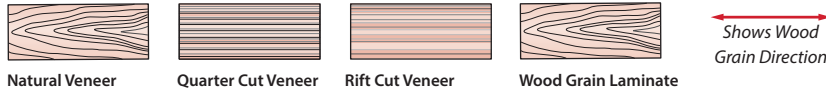

Natural Veneer

Quarter Cut Veneer

Rift Cut Veneer

Wood Grain Laminate

Shows Wood Grain Direction

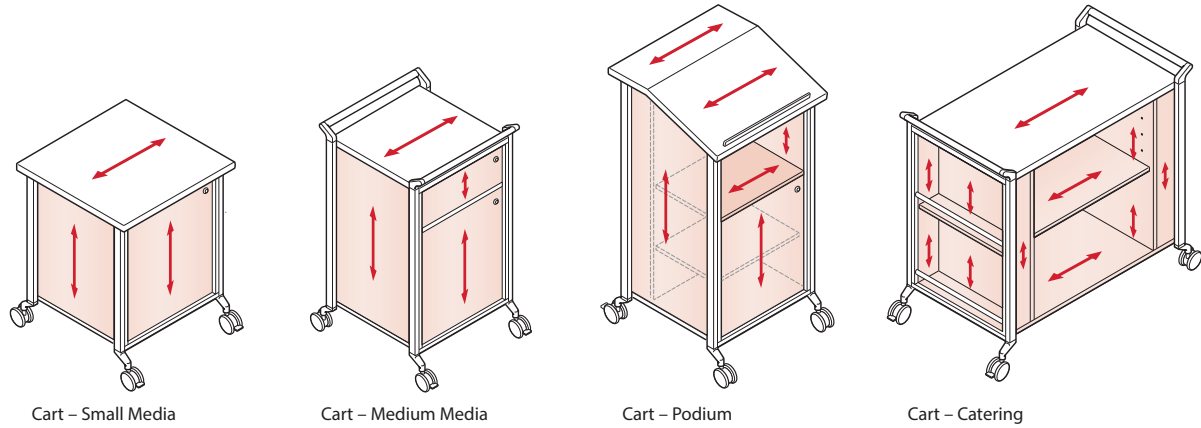

Cart – Small Media

Cart – Medium Media

Cart – Podium

Cart – Catering

Note • Cart – Catering is only available with Laminate finish.

Wood Grain Direction – Double Cut Veneer

Vertical Surfaces – Wood grain direction runs side-to-side on door fronts, back panels, side panels and most vertical surfaces.

Horizontal Surfaces – Wood grain direction runs side-to-side on tops, shelves and most horizontal surfaces.

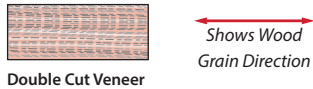

Double Cut Veneer

Shows Wood Grain Direction

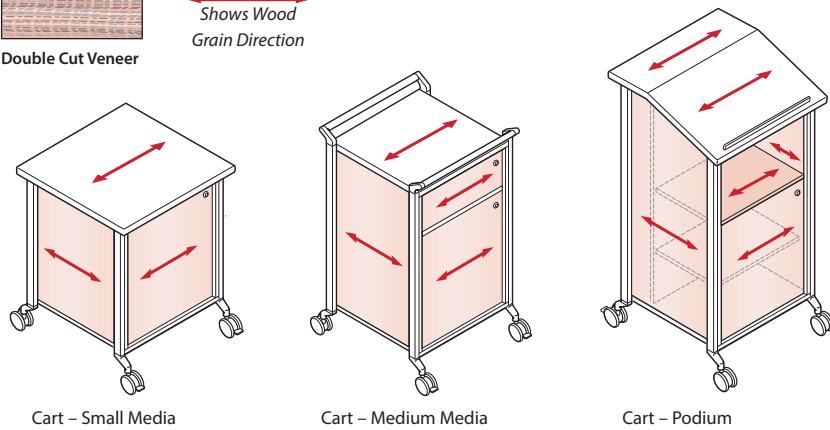

Cart – Small Media

Cart – Medium Media

Cart – Podium

Product Details – Planes Carts

Cart – Small Media

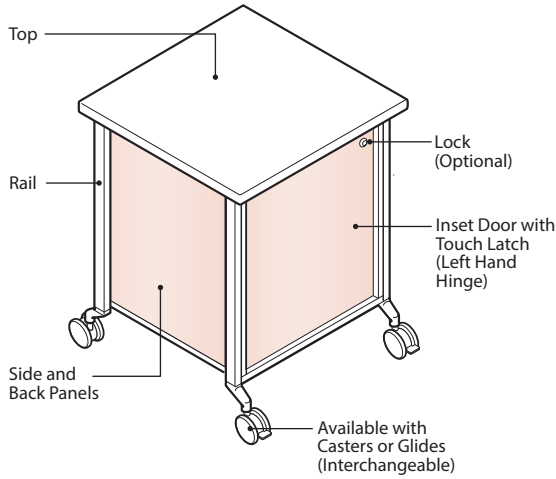

Component Materials/Finishes

COMPONENT NAME	MATERIALS/ FINISHES
Door, Top, Adjustable Shelf, Bottom, Sides, and Back Panels	Laminate – Specify surface color and separate edge color.
	Wood – Specify surface and edge wood finish color.
Rail	Painted Aluminum – Specify trim color
Casters (Optional)	(TR-F) Black hub with black tread
	(TR-7) Fog hub with graphite tread
	(TR-LPL) Light platinum hub with Graphite Tread
Glides (Optional)	(TR-F) Black Base Disk – Glide stem is painted to match base
	(TR-7) Fog Base Disk – Glide stem is painted to match base
	(TR-LPL) Light platinum Base Disk – Glide stem is painted to match base
Lock (Optional)	Available in Black or Chrome

Caster and Glide Options

- Optional casters or glides are field interchangeable.
- Casters include two locking and two non-locking.
- Heights are the same for Carts with Casters or Glides (Glides provide 1/2" of vertical adjustment for leveling).
- Casters/Glides Finish options:

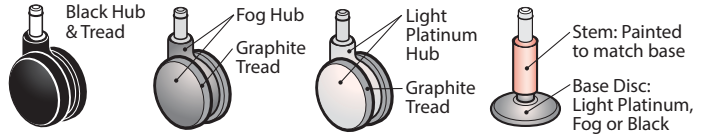

Cart Dimensions

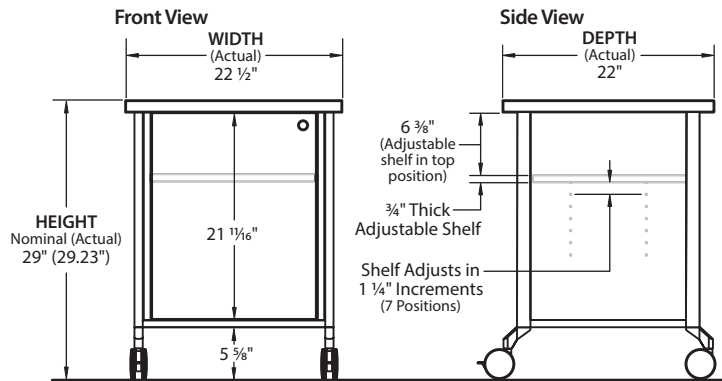

Interior Dimensions

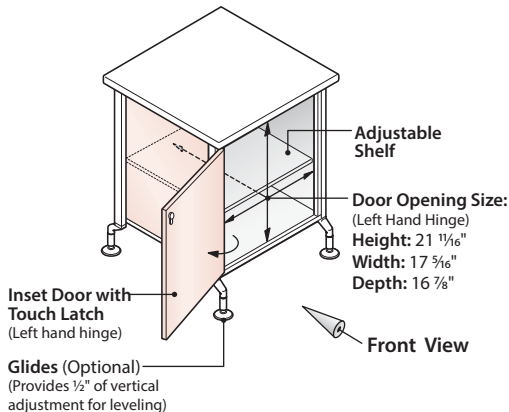

Product Details – Planes Carts

Cart – Medium Media

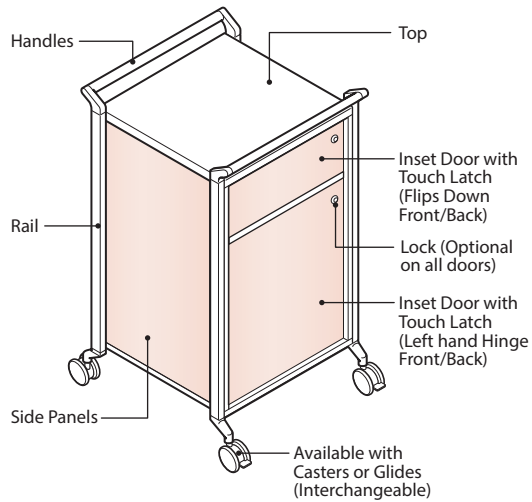

Component Materials/Finishes

COMPONENT NAME	MATERIALS/ FINISHES
Door, Top, Adjustable Shelf, Bottom, Sides, and Back Panels • Includes 1mm laminate or wood edgeband.	Laminate – Specify surface color and separate edge color.
	Wood – Specify surface and edge wood finish color.
Rails and Handles	Painted Aluminum – Specify trim color
Casters (Optional)	(TR-F) Black hub with black tread
	(TR-7) Fog hub with graphite tread
	(TR-LPL) Light platinum hub with Graphite Tread
Glides (Optional)	(TR-F) Black Base Disk – Glide stem is painted to match base
	(TR-7) Fog Base Disk – Glide stem is painted to match base
	(TR-LPL) Light platinum Base Disk – Glide stem is painted to match base
Lock (Optional on all Doors)	Available in Black or Chrome

Caster and Glide Options

- Optional casters or glides are field interchangeable.
- Casters include two locking and two non-locking.
- Heights are the same for Carts with Casters or Glides (Glides provide ½" of vertical adjustment for leveling).
- Casters/Glides Finish options:

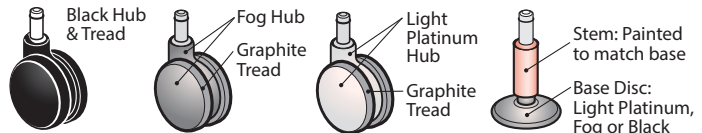

Interior Dimensions

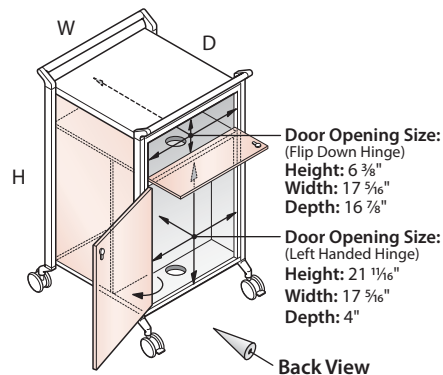
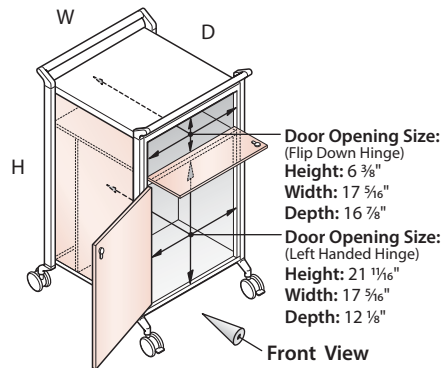

Dimensions

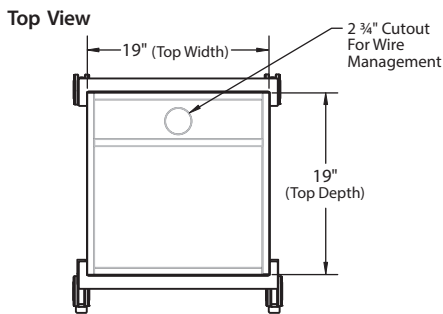

Front View

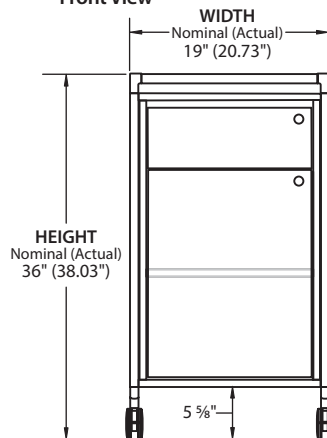

Side View

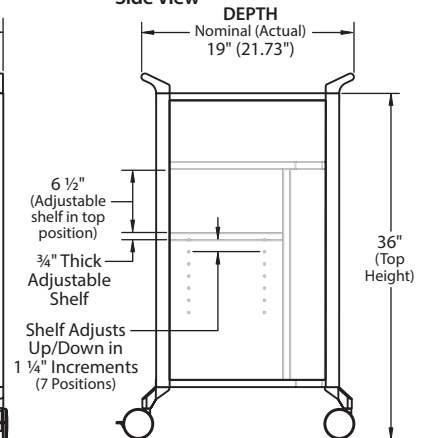

Product Details – Planes Carts

Cart – Catering

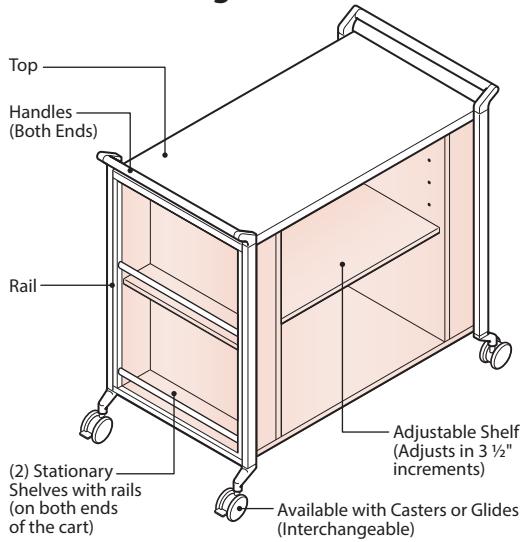

Component Materials/Finishes

COMPONENT NAME	MATERIALS/ FINISHES
Top, Shelves, Bottom, Sides and Back Panels • Includes 1mm laminate or edgeband.	Laminate – Specify surface color and separate edge color.
Rails and Handles	Painted Aluminum – Specify trim color.
Casters (Optional)	(TR-F) Black hub with black tread
	(TR-7) Fog hub with graphite tread
	(TR-LPL) Light platinum hub with Graphite Tread
Glides (Optional)	(TR-F) Black Base Disk – Glide stem is painted to match base
	(TR-7) Fog Base Disk – Glide stem is painted to match base
	(TR-LPL) Light platinum Base Disk – Glide stem is painted to match base

Caster and Glide Options

- Optional casters or glides are field interchangeable.
- Casters include two locking and two non-locking.
- Heights are the same for Carts with Casters or Glides (Glides provide 1/2" of vertical adjustment for leveling).
- Casters/Glides Finish options:

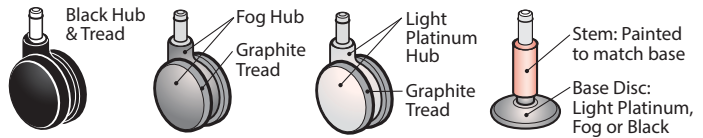

Interior Dimensions

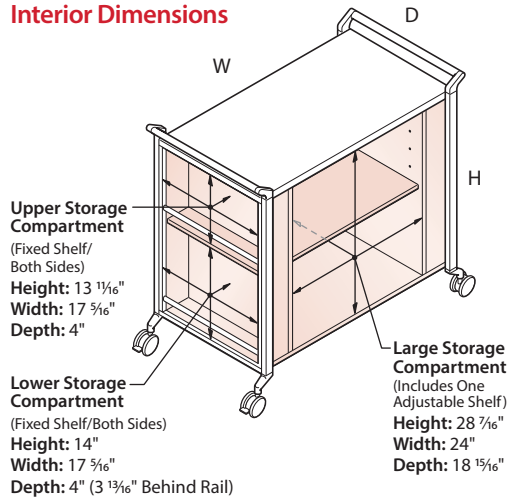

Dimensions

Top View

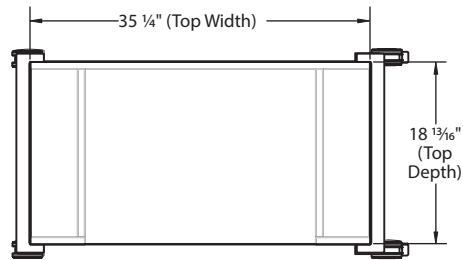

Front View

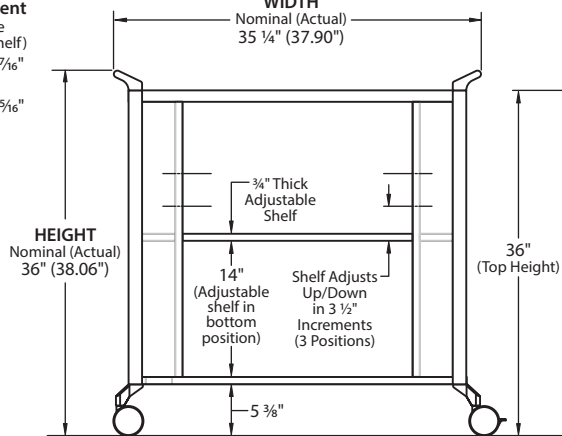

Side View

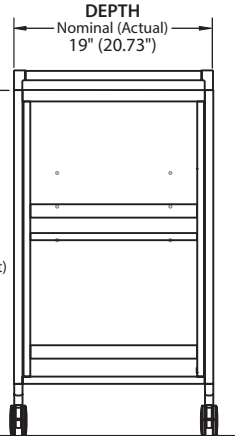

Product Details – Planes Carts

Cart – Podium

User Side

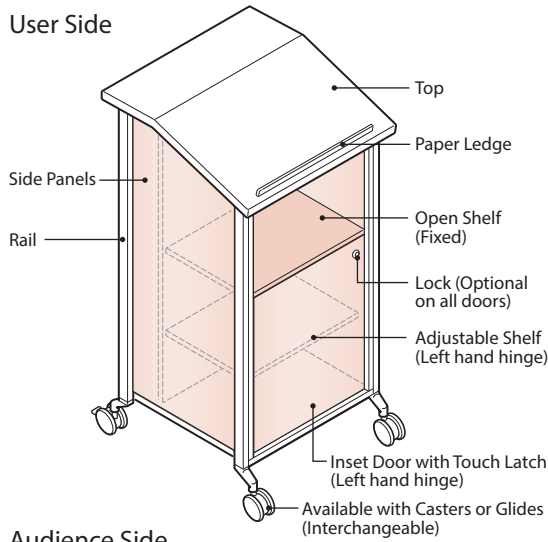

Audience Side

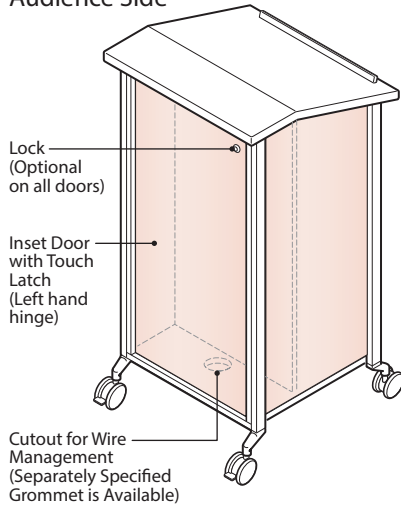

Dimensions

Top View

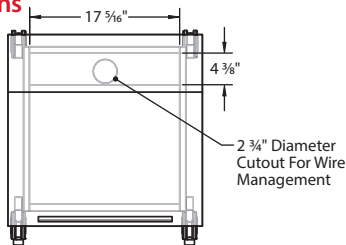

Front View

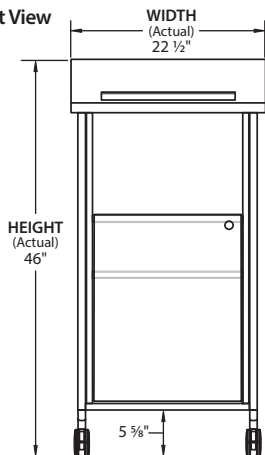

Side View

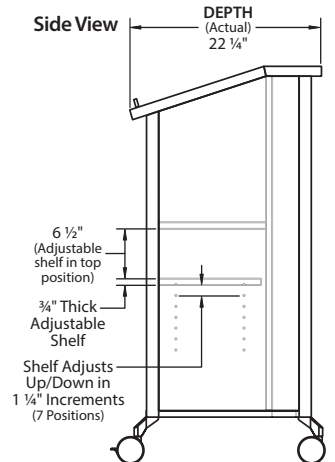

Component Materials/Finishes

COMPONENT NAME	MATERIALS/ FINISHES
Top, Doors, Shelves and Sides • Includes 1mm laminate or wood edgeband.	Laminate – Specify surface color and separate edge color.
	Wood – Specify surface and edge wood finish color.
Rails / Paper Ledge	Painted Aluminum – Specify trim color.
Casters (Optional)	(TR-F) Black hub with black tread
	(TR-7) Fog hub with graphite tread
	(TR-LPL) Light platinum hub with Graphite Tread
Glides (Optional)	(TR-F) Black Base Disk – Glide stem is painted to match base
	(TR-7) Fog Base Disk – Glide stem is painted to match base
	(TR-LPL) Light platinum Base Disk –Glide stem is painted to match base
Lock (Optional)	Available in Black or Chrome

Caster and Glide Options

- Optional casters or glides are field interchangeable.
- Casters include two locking and two non-locking.
- Heights are the same for Carts with Casters or Glides (Glides provide 1/2" of vertical adjustment for leveling).
- Casters/Glides Finish options:

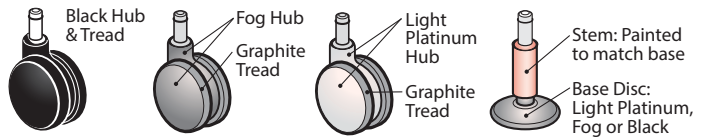

Interior Dimensions

User Side

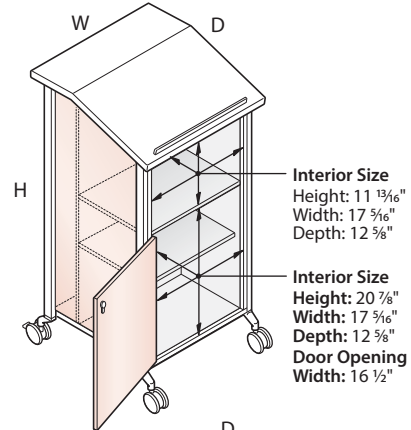

Audience Side

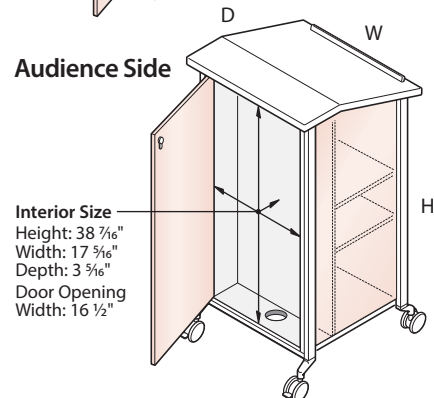

Product Details – Credenzas

Overview

- Planes offers a wide variety of sizes of Credenzas for your storage needs.
- Credenzas have the option of laminate or wood and the Slider Unit has glass and translucent door options.

Wood Grain Direction – Natural Veneer, Quarter Cut Veneer, Rift Cut Veneer and Wood Grain Laminate

Vertical Surfaces – Wood grain direction runs top-to-bottom on door fronts, back panels, side panels and most vertical surfaces.

Horizontal Surfaces – Wood grain direction runs side-to-side on tops, shelves and most horizontal surfaces.

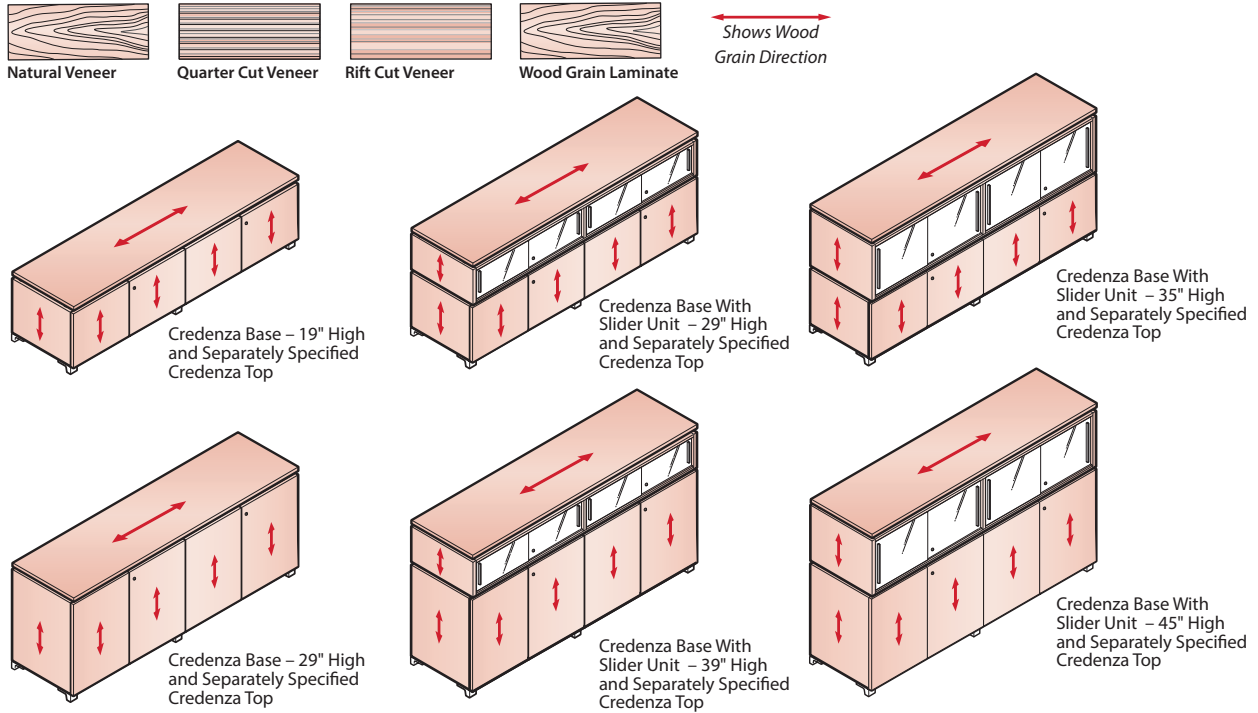

Wood Grain Direction – Double Cut Veneer

Vertical Surfaces – Wood grain direction runs side-to-side on door fronts, back panels, side panels and most vertical surfaces.

Horizontal Surfaces – Wood grain direction runs side-to-side on tops, shelves and most horizontal surfaces.

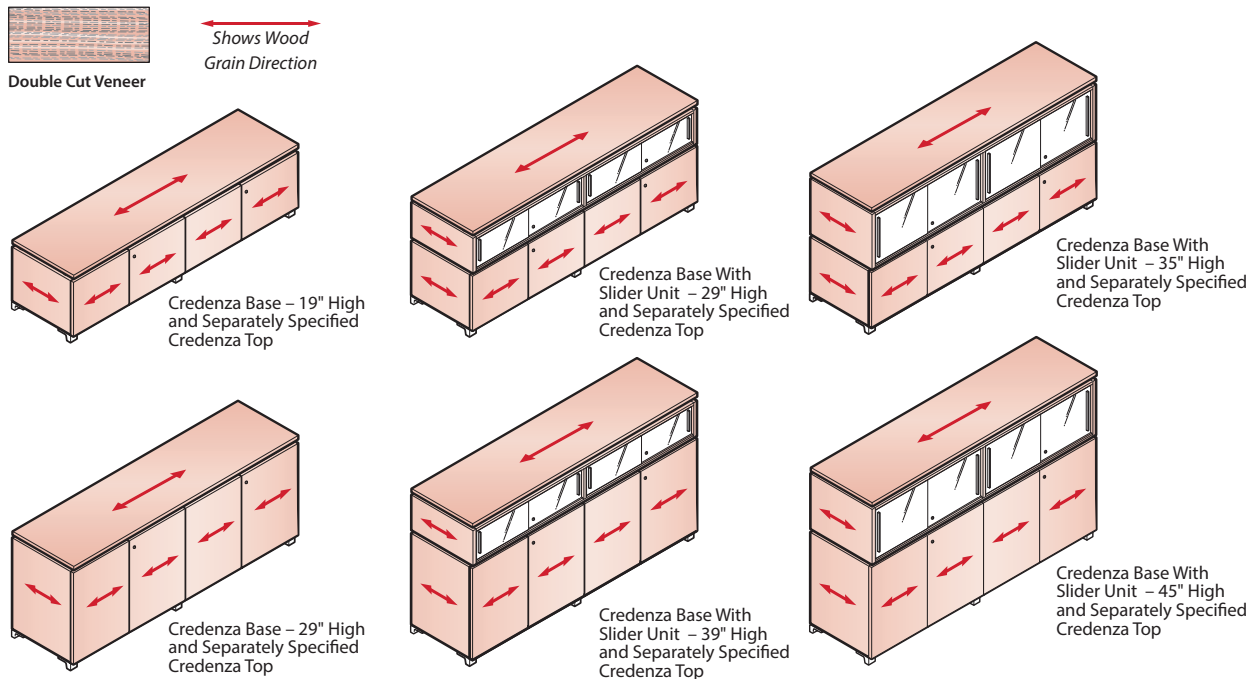

Product Details – Credenzas

Credenza Tops

- Planes Credenzas Bases and Credenza Bases with Slider Unit require a separately specified Credenza Top for a finished aesthetic.
- Specify the Credenza Top the same width as the Credenza Base.
- The hardware to install the Credenza Top is included and the attachment locations are factory drilled in the base or slider units.

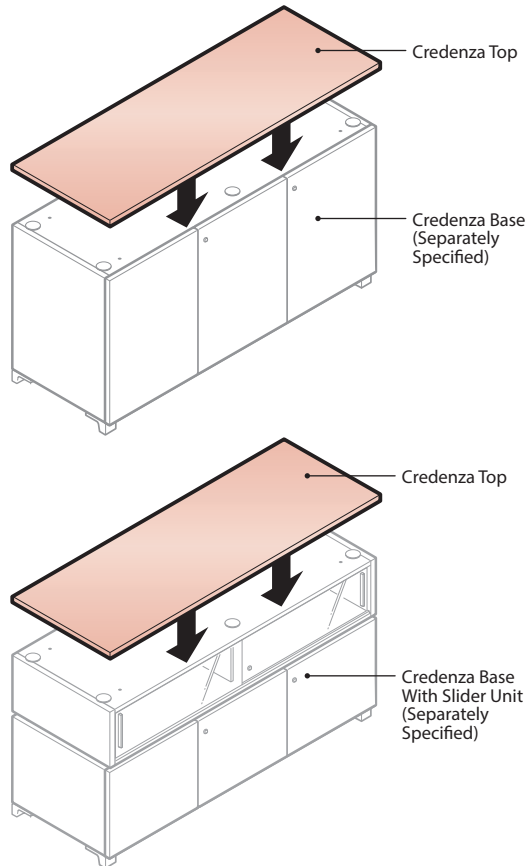

Component Materials/Finishes

COMPONENT NAME	MATERIALS/ FINISHES
Credenza Top • Includes laminate or wood edgeband.	Laminate – Specify surface color and separate edge color.
	Wood – Specify surface and edge wood finish color.

Dimensions

Top View

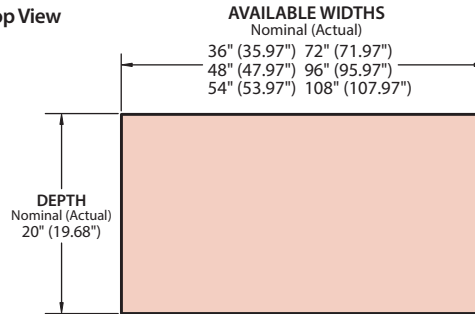

Front View

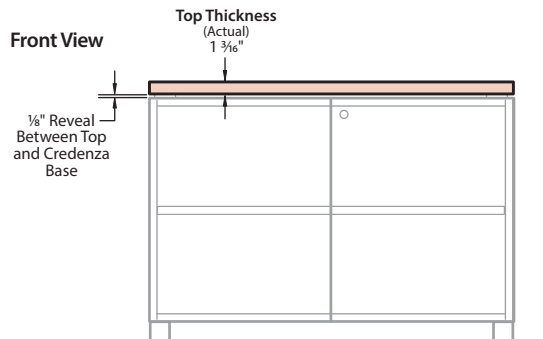

Product Details – Credenzas

Credenza Base – 19" High

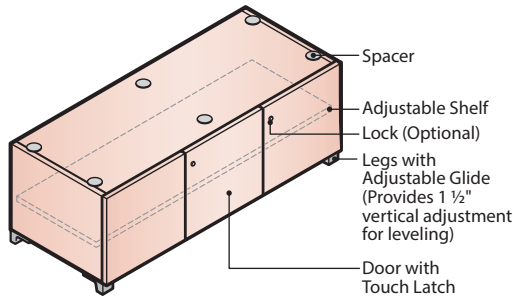

- The 19" High Credenza Base requires a separately specified Credenza Top to finish the top (Specify width of Credenza Top to match width of Credenza).
- Fixed vertical dividers are used to sub-divide interior compartments (Exception: 36" wide unit does not include vertical dividers).
- Each interior compartment in the Credenza Base includes (1) adjustable shelf.

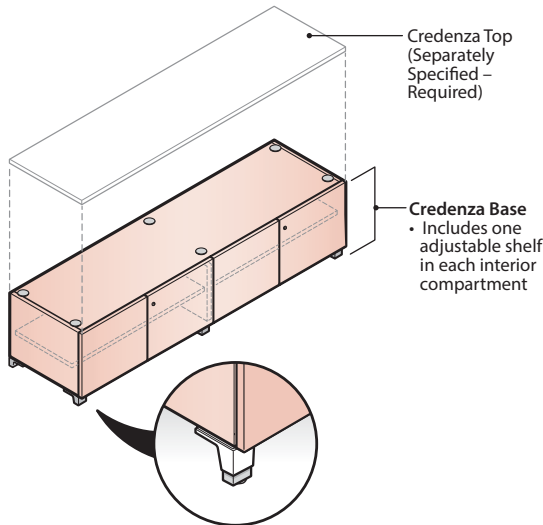

Detail of Credenza Leg

- Painted Metal with Black Glide.
- Leg is 2 1/4" High.
- Glide provides 1 1/2" of vertical adjustment for leveling.

Component Materials/Finishes

COMPONENT NAME	MATERIALS/ FINISHES
Hinged Doors, Tops, Bottoms, Sides, Backs, Shelves and Dividers Include 1mm laminate or wood edgeband.	Laminate – Specify surface color and separate edge color. Wood – Specify surface and edge wood finish color. (Door fronts are matched veneer)
Leg	Painted Aluminum – Specify trim color Glides – Standard in Black
Lock (Optional)	Locks are available in Black or Chrome.

19" High – Credenza Base Configurations

- Illustration show position and quantity of doors and locks.
- Red Arrows show door swing.

36" Wide

- 19" High Credenza Base**
- (2) Hinged Doors
 - (1) Shelf
 - (4) Legs

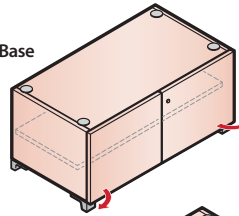

48" Wide

- 19" High Credenza Base**
- (3) Hinged Doors
 - (1) Divider
 - (2) Shelves
 - (4) Legs

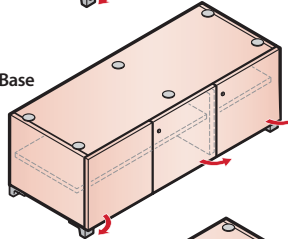

54" Wide

- 19" High Credenza Base**
- (3) Hinged Doors
 - (1) Divider
 - (2) Shelves
 - (4) Legs

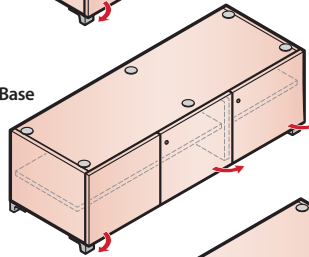

72" Wide

- 19" High Credenza Base**
- (4) Hinged Doors
 - (1) Divider
 - (2) Shelves
 - (6) Legs

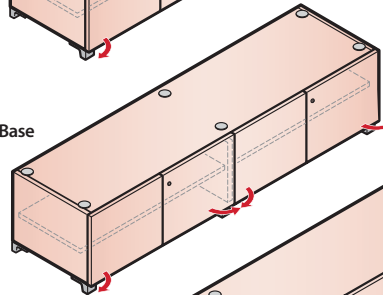

96" Wide

- 19" High Credenza Base**
- (6) Hinged Doors
 - (2) Divider
 - (3) Shelves
 - (6) Legs

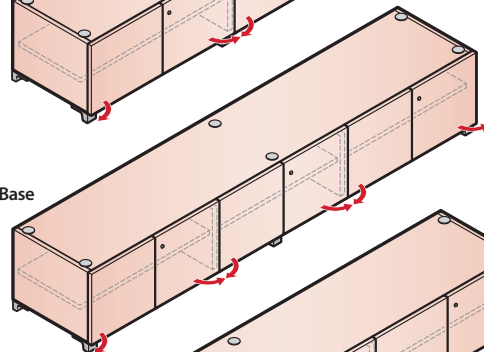

108" Wide

- 28" High Credenza Base**
- (6) Hinged Doors
 - (2) Divider
 - (3) Shelves
 - (6) Legs

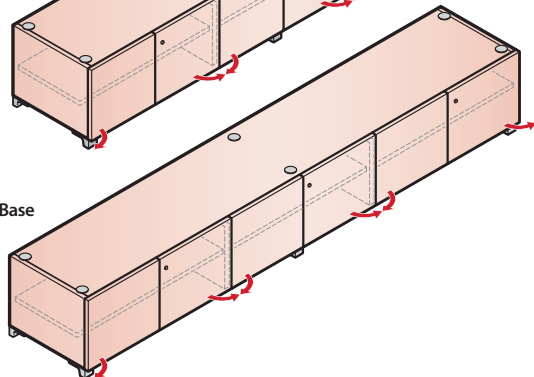

Product Details – Credenzas

Credenza Base – 19" High

Dimensions

Front View – 19" High x 36" Wide (2 Doors/4 Legs)

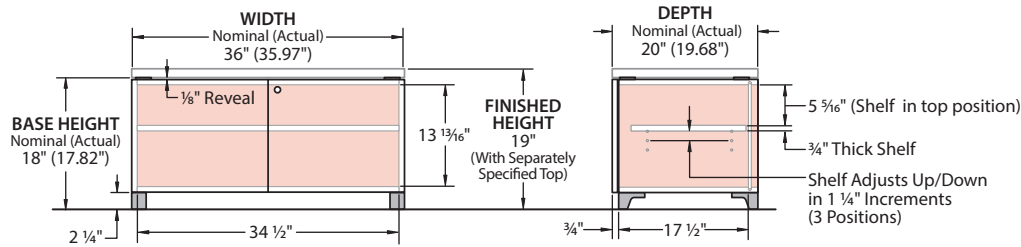

48" Wide (3 Doors/4 Legs)

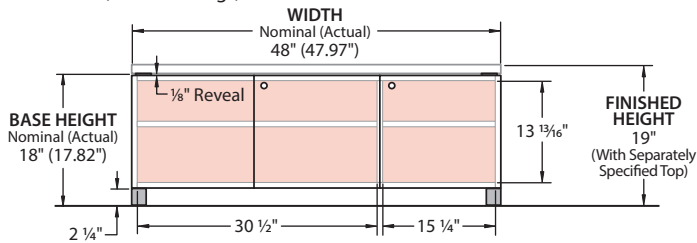

54" Wide (3 Doors/4 Legs)

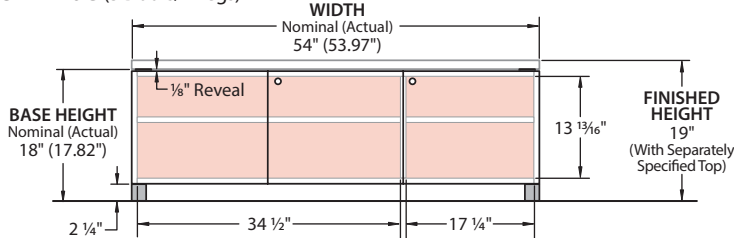

72" Wide (4 Doors/6 Legs)

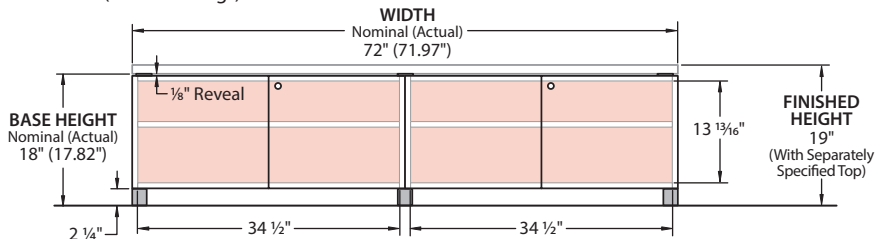

96" Wide (6 Doors/6 Legs)

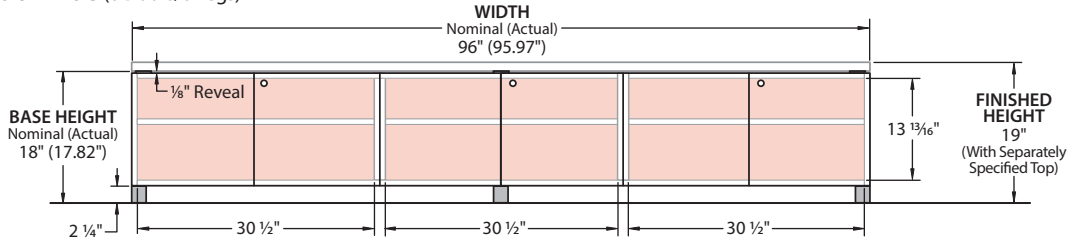

108" Wide (6 Doors/6 Legs)

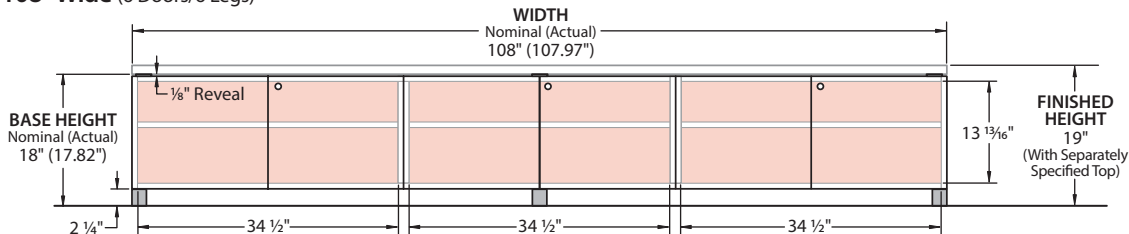

Note The side view dimensions for the 36" wide Credenza are the same for all 19" High Credenzas.

Product Details – Credenzas

Credenza Base with Slider Unit– 29" High

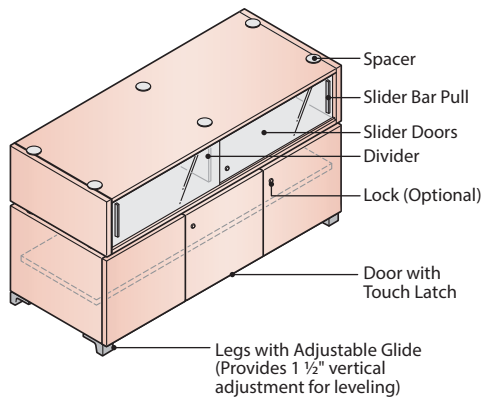

- The 29" High Credenza Base with Slider Unit includes a 10" High Slider Unit attached a 18" High Credenza Base.
- A separately specified Credenza Top is required to finish the top (Specify width of Credenza Top to match width of Credenza).
- Fixed vertical dividers are used to sub-divide interior compartments (Exception: 36" wide unit does not include vertical dividers).
- Each interior compartment in the Credenza Base includes (1) adjustable shelf (Slider Unit does not include Adjustable Shelves).

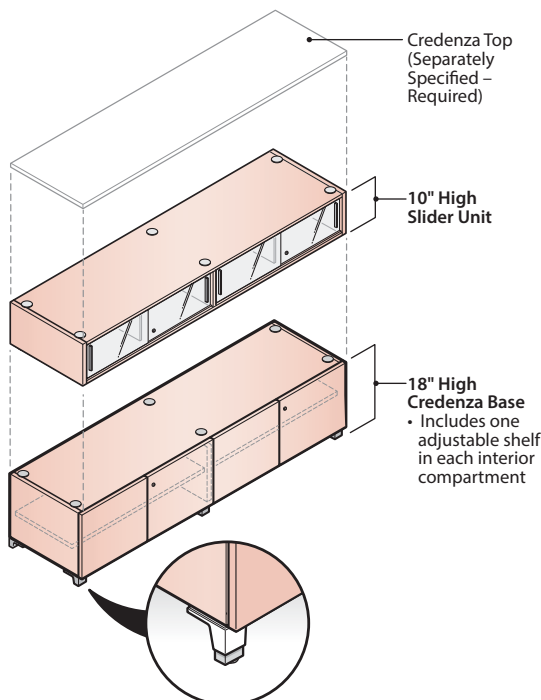

Detail of Credenza Leg

- Painted Metal with Black Glide.
- Leg is 2 1/4" High.
- Glide provides 1 1/2" of vertical adjustment for leveling.

Component Materials/Finishes

COMPONENT NAME	MATERIALS/ FINISHES
Hinged Doors, Tops, Bottoms, Sides, Backs, Shelves and Dividers Include 1mm laminate or wood edgeband.	Laminate – Specify surface color and separate edge color. Wood – Specify surface and edge wood finish color. (Base Door fronts are matched veneer)
Leg	Painted Aluminum – Specify trim color (matches Slider Bar Pull) Glides – Standard in Black
Slider Bar Pull	Painted Aluminum – Specify trim color (matches Leg)
Slider Doors	Available in Glass or Translucent
Lock (Optional)	Locks are available in Black or Chrome.

29" High – Credenza Base with Slider Unit Configurations

- Illustration show position and quantity of doors and locks.
- Red Arrows show door swing.

36" Wide

- 10" High Slider Unit
- (2) Slider Doors
- 18" High Credenza Base
- (2) Hinged Doors
- (1) Shelf
- (4) Legs

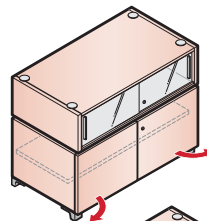

48" Wide

- 10" High Slider Unit
- (2) Slider Doors
- (1) Divider
- 18" High Credenza Base
- (3) Hinged Doors
- (1) Divider
- (2) Shelves
- (4) Legs

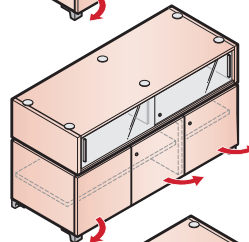

54" Wide

- 10" High Slider Unit
- (2) Slider Doors
- (1) Divider
- 18" High Credenza Base
- (3) Hinged Doors
- (1) Divider
- (2) Shelves
- (4) Legs

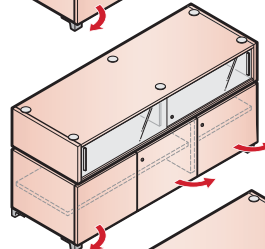

72" Wide

- 10" High Slider Unit
- (4) Slider Doors
- (1) Divider
- 18" High Credenza Base
- (4) Hinged Doors
- (1) Divider
- (2) Shelves
- (6) Legs

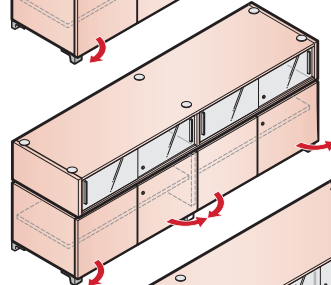

96" Wide

- 10" High Slider Unit
- (4) Slider Doors
- (3) Dividers
- 18" High Credenza Base
- (6) Hinged Doors
- (2) Divider
- (3) Shelves
- (6) Legs

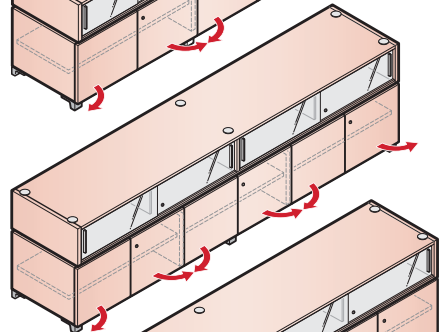

108" Wide

- 10" High Slider Unit
- (4) Slider Doors
- (3) Dividers
- 18" High Credenza Base
- (6) Hinged Doors
- (2) Divider
- (3) Shelves
- (6) Legs

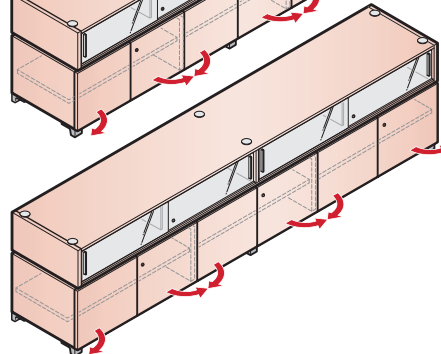

Product Details – Credenzas

Credenza Base with Slider Unit – 29" High

Dimensions

Front View – 29" High x 36" Wide (2 Doors/4 Legs)

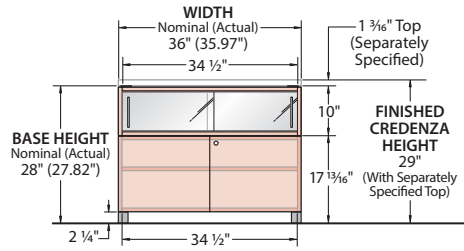

Side View – 29" High Credenza (All Widths)

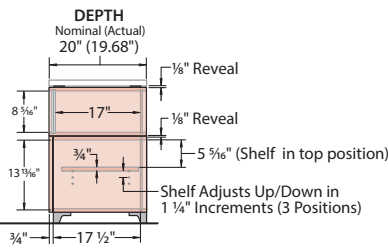

Front View – 29" High x 48" Wide (3 Doors/4 Legs)

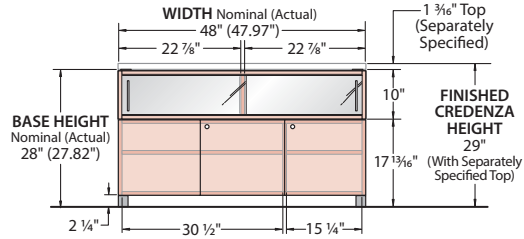

Front View – 29" High x 54" Wide (3 Doors/4 Legs)

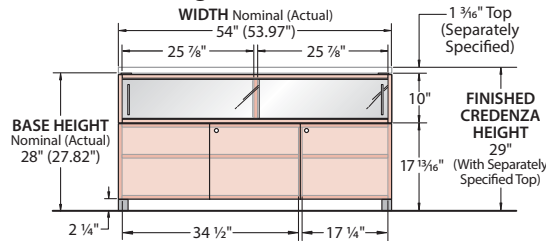

Front View – 29" High x 72" Wide (4 Doors/6 Legs)

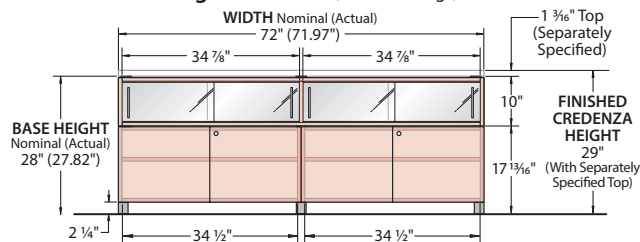

Front View – 29" High x 96" Wide (6 Doors/6 Legs)

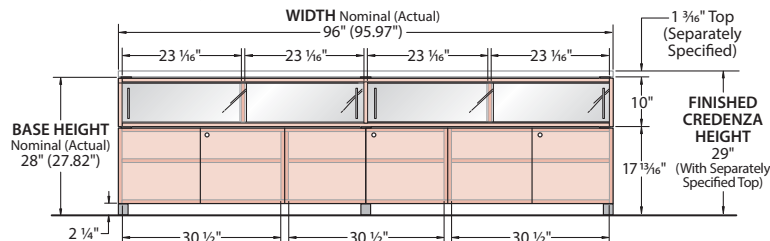

Front View – 29" High x 108" Wide (6 Doors/6 Legs)

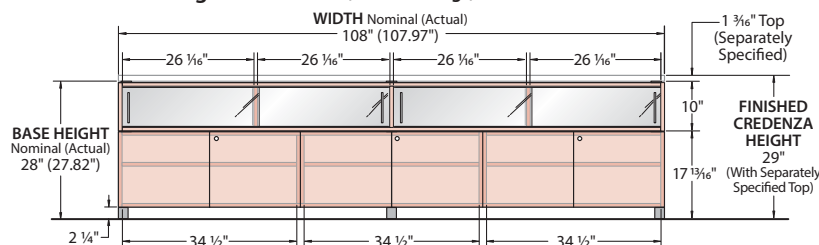

Note The side view dimensions for the 36" wide Credenza are the same for all 29" High Credenzas.

Product Details – Credenzas

Credenza Base with Slider Unit– 35" High

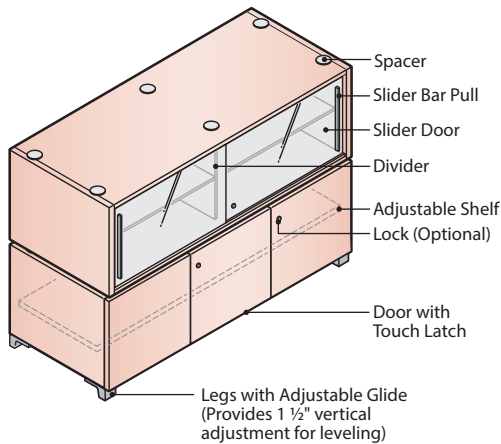

- The 29" High Credenza Base with Slider Unit includes a 10" High Slider Unit attached a 18" High Credenza Base.
- A separately specified Credenza Top is required to finish the top (Specify width of Credenza Top to match width of Credenza).
- Fixed vertical dividers are used to sub-divide interior compartments (Exception: 36" wide unit does not include vertical dividers).
- Each interior compartment in the Slider Unit and Credenza Base includes (1) adjustable shelf.

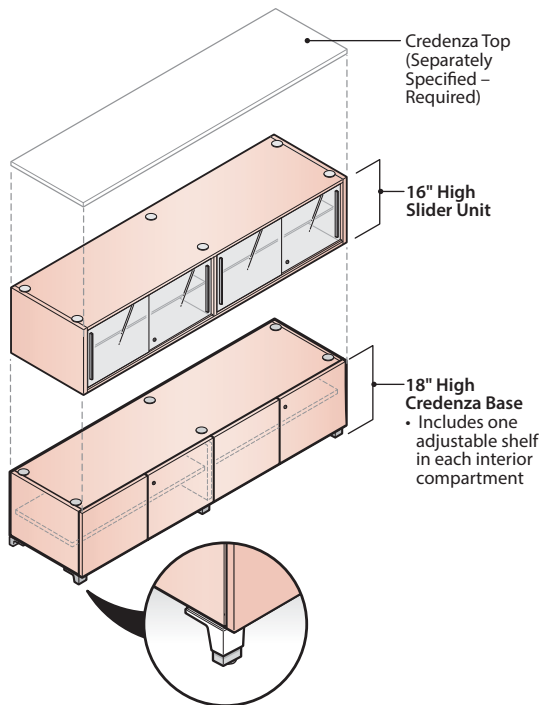

Detail of Credenza Leg

- Painted Metal with Black Glide.
- Leg is 2 ¼" High.
- Glide provides 1 ½" of vertical adjustment for leveling.

Component Materials/Finishes

COMPONENT NAME	MATERIALS/ FINISHES
Hinged Doors, Tops, Bottoms, Sides, Backs, Shelves and Dividers Include 1mm laminate or wood edgeband.	Laminate – Specify surface color and separate edge color.
	Wood – Specify surface and edge wood finish color. (Door fronts are matched veneer)
Leg	Painted Aluminum – Specify trim color (matches Slider Bar Pull) Glides – Standard in Black
Slider Bar Pull	Painted Aluminum – Specify trim color (matches Leg)
Slider Doors	Available in Glass or Translucent
Lock (Optional)	Locks are available in Black or Chrome.

19" High Credenza Base Configurations

- Illustration show position and quantity of doors and locks.
- Red Arrows show door swing.

36" Wide

- 16" High Slider Unit**
 - (2) Slider Doors
 - (1) Shelf
- 18" High Credenza Base**
 - (2) Hinged Doors
 - (1) Shelf
 - (4) Legs

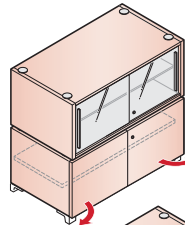

48" Wide

- 16" High Slider Unit**
 - (2) Slider Doors
 - (1) Divider
 - (2) Shelves
- 18" High Credenza Base**
 - (3) Hinged Doors
 - (1) Divider
 - (2) Shelves
 - (4) Legs

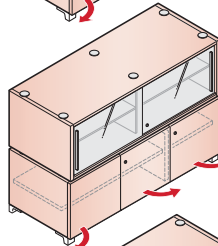

54" Wide

- 16" High Slider Unit**
 - (2) Slider Doors
 - (1) Divider
 - (2) Shelves
- 18" High Credenza Base**
 - (3) Hinged Doors
 - (1) Divider
 - (2) Shelves
 - (4) Legs

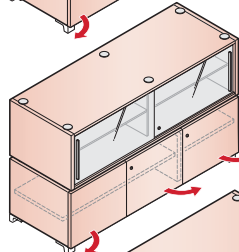

72" Wide

- 16" High Slider Unit**
 - (4) Slider Doors
 - (1) Divider
 - (2) Shelves
- 18" High Credenza Base**
 - (4) Hinged Doors
 - (1) Divider
 - (2) Shelves
 - (6) Legs

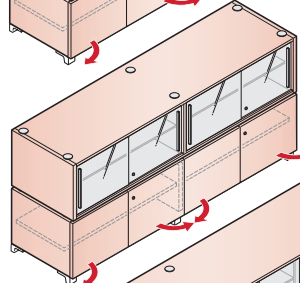

96" Wide

- 16" High Slider Unit**
 - (4) Slider Doors
 - (3) Dividers
 - (4) Shelves
- 18" High Credenza Base**
 - (6) Hinged Doors
 - (2) Dividers
 - (3) Shelves
 - (6) Legs

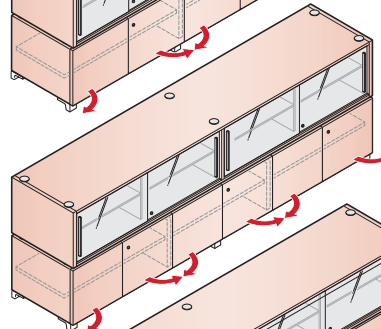

108" Wide

- 16" High Slider Unit**
 - (4) Slider Doors
 - (3) Dividers
 - (4) Shelves
- 18" High Credenza Base**
 - (6) Hinged Doors
 - (2) Dividers
 - (3) Shelves
 - (6) Legs

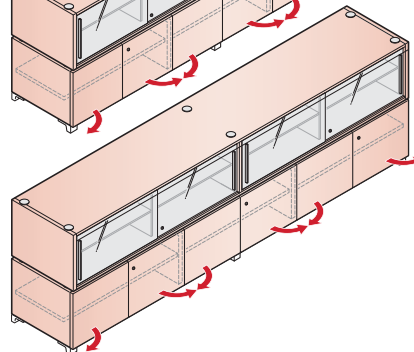

Product Details – Credenzas

Credenza Base with Slider Unit– 35" High

Dimensions

Front View – 35" High x 36" Wide (2 Doors/4 Legs)

Side View – 35" High Credenza (All Widths)

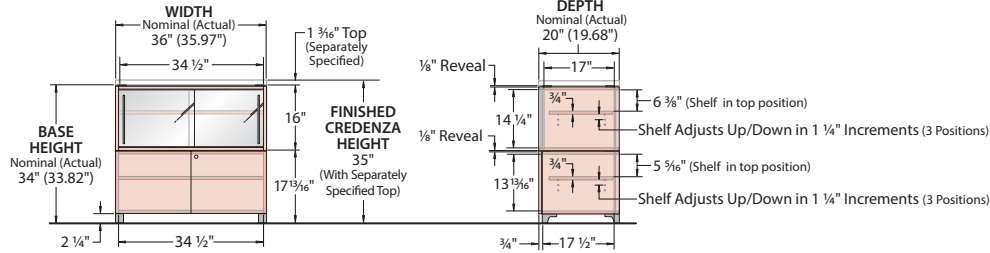

Front View – 35" High x 48" Wide (3 Doors/4 Legs)

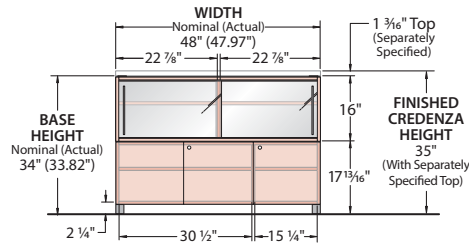

Front View – 35" High x 54" Wide (3 Doors/4 Legs)

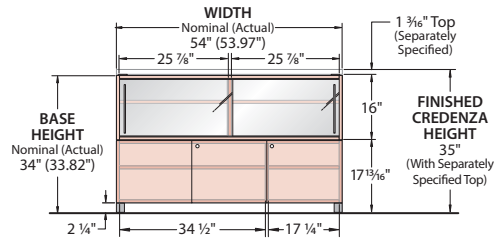

Front View – 35" High x 72" Wide (4 Doors/6 Legs)

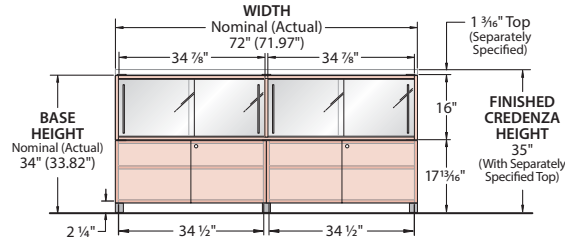

Front View – 35" High x 96" Wide (6 Doors/6 Legs)

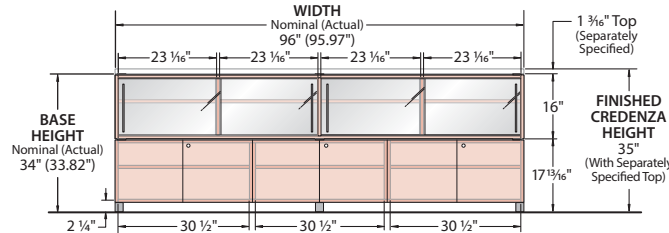

Front View – 35" High x 108" Wide (6 Doors/6 Legs)

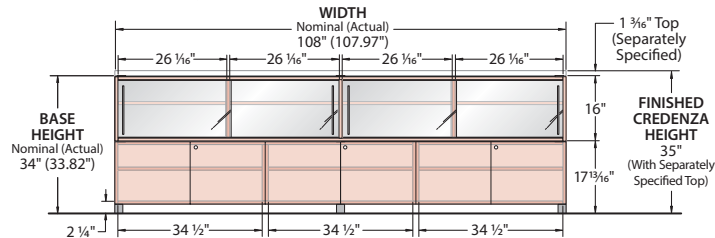

Note The side view dimensions for the 36" wide Credenza are the same for all 35" High Credenzas.

Product Details – Credenzas

Credenza Base – 29" High

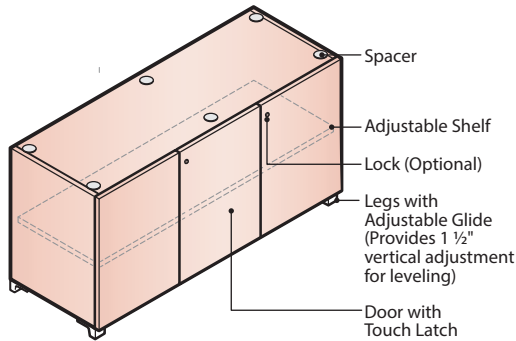

- The 29" High Credenza Base requires a separately specified Credenza Top to finish the top (Specify width of Credenza Top to match width of Credenza).
- Fixed vertical dividers are used to sub-divide interior compartments (Exception: 36" wide unit does not include vertical dividers).
- Each interior compartment in the Credenza Base includes (1) adjustable shelf.

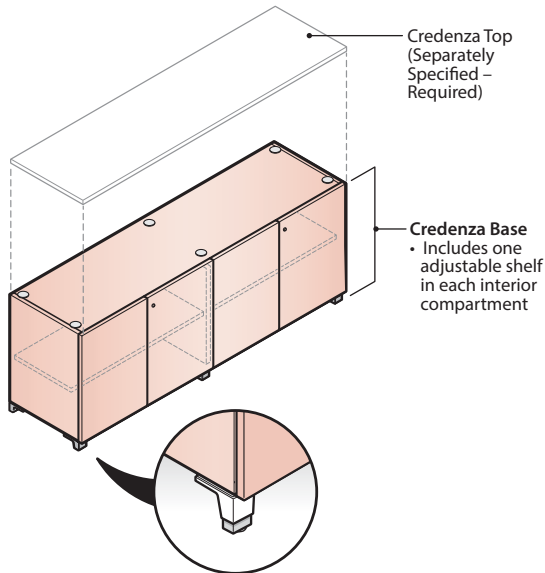

Detail of Credenza Leg

- Painted Metal with Black Glide.
- Leg is 2 1/4" High.
- Glide provides 1 1/2" of vertical adjustment for leveling.

Component Materials/Finishes

COMPONENT NAME	MATERIALS/ FINISHES
Hinged Doors, Tops, Bottoms, Sides, Backs, Shelves and Dividers Include 1mm laminate or wood edgeband.	Laminate – Specify surface color and separate edge color. Wood – Specify surface and edge wood finish color. (Door fronts are matched veneer)
Leg	Painted Aluminum – Specify trim color (matches Slider Bar Pull) Glides – Standard in Black
Lock (Optional)	Locks are available in Black or Chrome.

29" High Credenza Base Configurations

- Illustration show position and quantity of doors and locks.
- Red Arrows show door swing.

36" Wide

- 29" High Credenza Base
- (2) Hinged Doors
 - (1) Shelf
 - (4) Legs

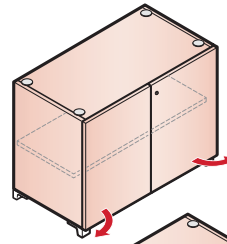

48" Wide

- 29" High Credenza Base
- (3) Hinged Doors
 - (1) Divider
 - (2) Shelves
 - (4) Legs

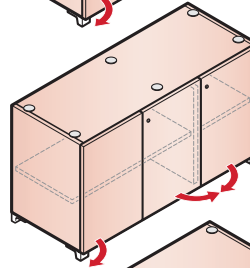

54" Wide

- 29" High Credenza Base
- (3) Hinged Doors
 - (1) Divider
 - (2) Shelves
 - (4) Legs

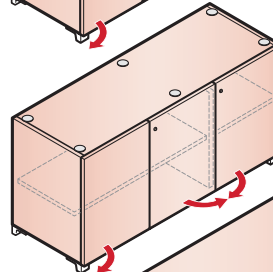

72" Wide

- 29" High Credenza Base
- (4) Hinged Doors
 - (1) Divider
 - (2) Shelves
 - (6) Legs

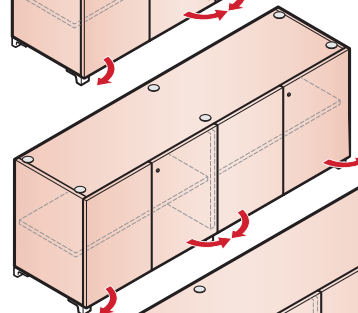

96" Wide

- 29" High Credenza Base
- (6) Hinged Doors
 - (2) Divider
 - (3) Shelves
 - (6) Legs

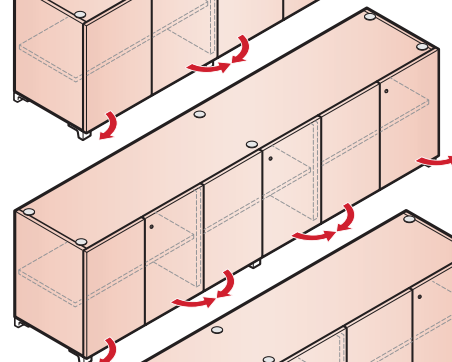

108" Wide

- 29" High Credenza Base
- (6) Hinged Doors
 - (2) Divider
 - (3) Shelves
 - (6) Legs

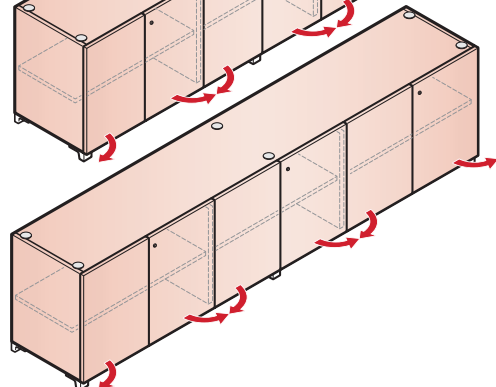

Product Details – Credenzas

Credenza Base – 29" High

Dimensions

Front View – 29" High x 36" Wide (2 Doors/4 Legs)

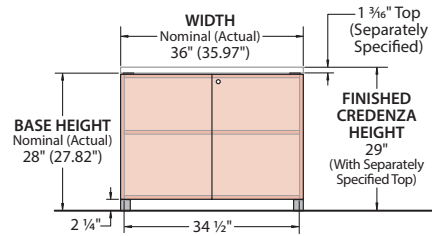

Side View – 29" High Credenza (All Widths)

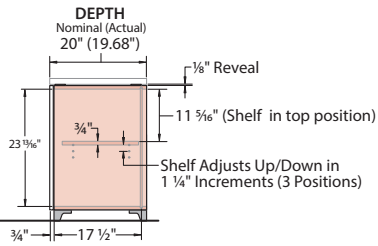

Front View – 29" High x 48" Wide (3 Doors/4 Legs)

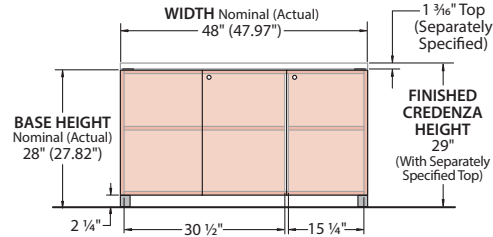

Front View – 29" High x 54" Wide (3 Doors/4 Legs)

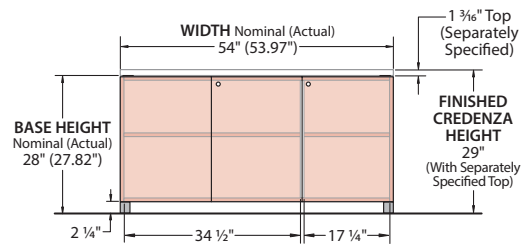

Front View – 29" High x 72" Wide (4 Doors/6 Legs)

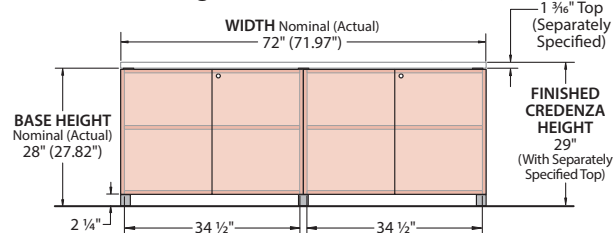

Front View – 29" High x 96" Wide (6 Doors/6 Legs)

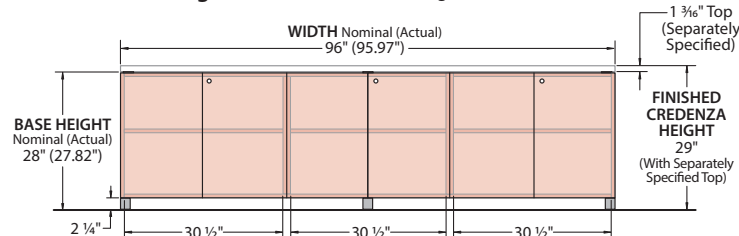

Front View – 29" High x 108" Wide (6 Doors/6 Legs)

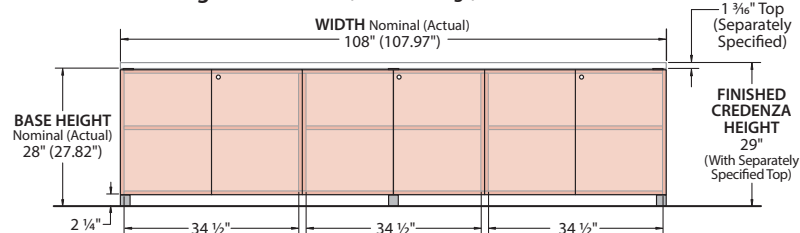

Note The side view dimensions for the 36" wide Credenza are the same for all 29" High Credenzas.

Product Details – Credenzas

Credenza Base with Slider Unit– 39" High

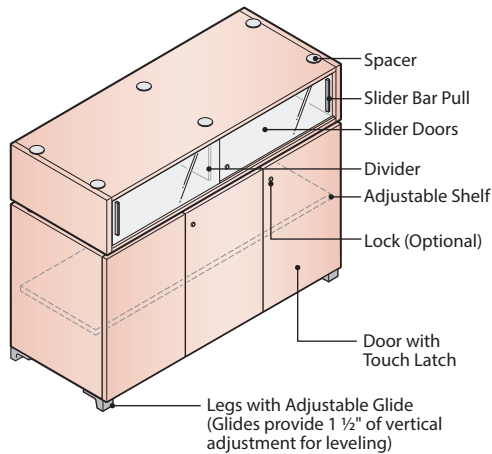

- The 39" High Credenza Base with Slider Unit includes a 10" High Slider Unit attached a 28" High Credenza Base.
- A separately specified Credenza Top is required to finish the top (Specify width of Credenza Top to match width of Credenza).
- Fixed vertical dividers are used to sub-divide interior compartments (Exception: 36" wide unit does not include vertical dividers).
- Each interior compartment in the Credenza Base includes (1) adjustable shelf (Slider Unit does not include Adjustable Shelves).

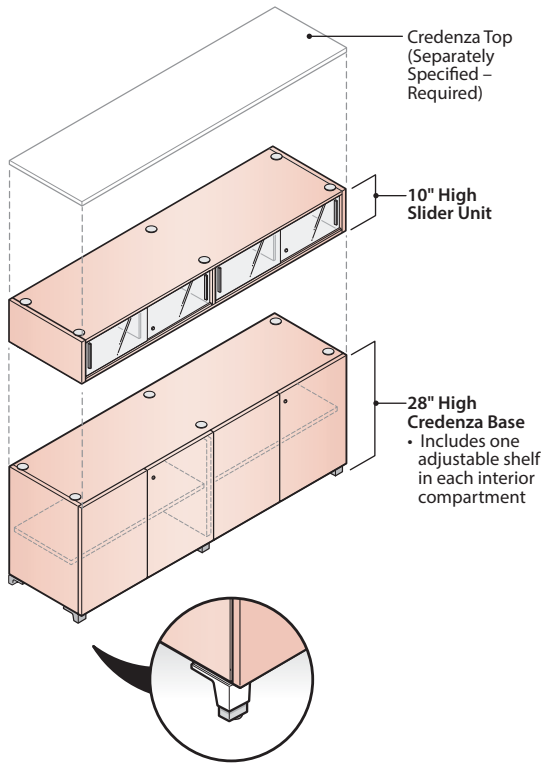

Detail of Credenza Leg

- Painted Metal with Black Glide.
- Leg is 2 1/4" High.
- Glide provides 1 1/2" of vertical adjustment for leveling.

Component Materials/Finishes

COMPONENT NAME	MATERIALS/ FINISHES
Hinged Doors, Tops, Bottoms, Sides, Backs, Shelves and Dividers Include 1mm laminate or wood edgeband.	Laminate – Specify surface color and separate edge color.
	Wood – Specify surface and edge wood finish color. (Door fronts are matched veneer)
Leg	Painted Aluminum – Specify trim color (matches Slider Bar Pull) Glides – Standard in Black
Slider Bar Pull	Painted Aluminum – Specify trim color (matches Leg)
Slider Doors	Available in Glass or Translucent
Lock (Optional)	Locks are available in Black or Chrome.

39" High Credenza Base with Slider Unit Configurations

- Illustration show position and quantity of doors and locks.
- Red Arrows show door swing.

36" Wide

- 10" High Slider Unit
- (2) Slider Doors
- 28" High Credenza Base
- (2) Hinged Doors
- (1) Shelf
- (4) Legs

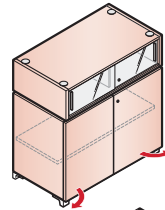

48" Wide

- 10" High Slider Unit
- (2) Slider Doors
- (1) Divider
- 28" High Credenza Base
- (3) Hinged Doors
- (1) Divider
- (2) Shelves
- (4) Legs

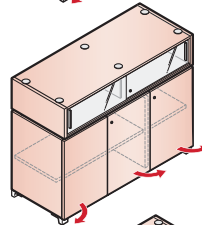

54" Wide

- 10" High Slider Unit
- (2) Slider Doors
- (1) Divider
- 28" High Credenza Base
- (3) Hinged Doors
- (1) Divider
- (2) Shelves
- (4) Legs

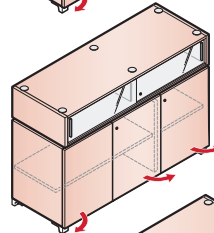

72" Wide

- 10" High Slider Unit
- (4) Slider Doors
- (1) Divider
- 28" High Credenza Base
- (4) Hinged Doors
- (1) Divider
- (2) Shelves
- (6) Legs

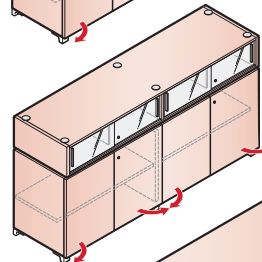

96" Wide

- 10" High Slider Unit
- (4) Slider Doors
- (3) Dividers
- 28" High Credenza Base
- (6) Hinged Doors
- (2) Divider
- (3) Shelves
- (6) Legs

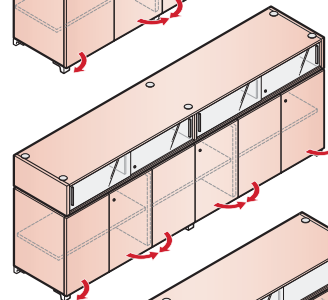

108" Wide

- 10" High Slider Unit
- (4) Slider Doors
- (3) Dividers
- 28" High Credenza Base
- (6) Hinged Doors
- (2) Divider
- (3) Shelves
- (6) Legs

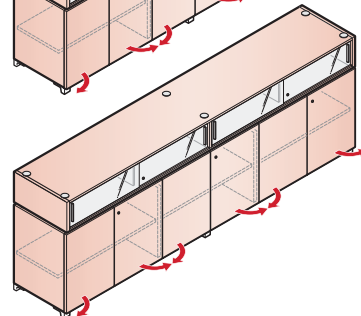

Product Details – Credenzas

Credenza Base with Slider Unit– 39" High

Dimensions

Front View – 39" High x 36" Wide (2 Doors/4 Legs)

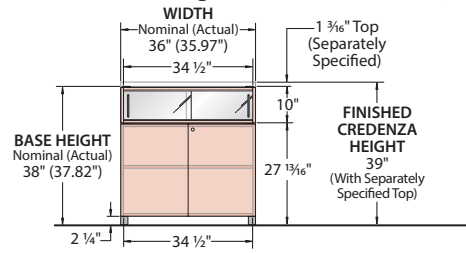

Side View – 39" High Credenza (All Widths)

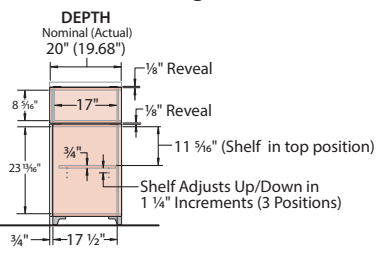

Front View – 39" High x 48" Wide (3 Doors/4 Legs)

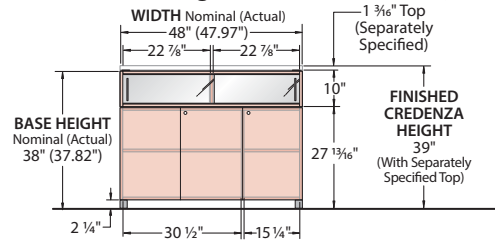

Front View – 39" High x 54" Wide (3 Doors/4 Legs)

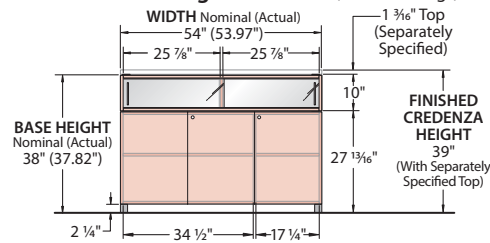

Front View – 39" High x 72" Wide (4 Doors/6 Legs)

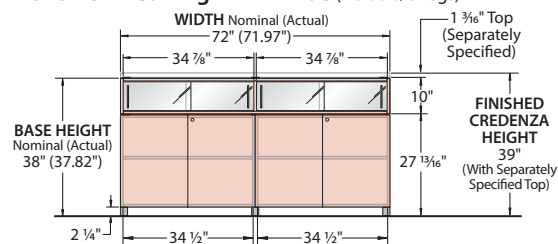

Front View – 39" High x 96" Wide (6 Doors/6 Legs)

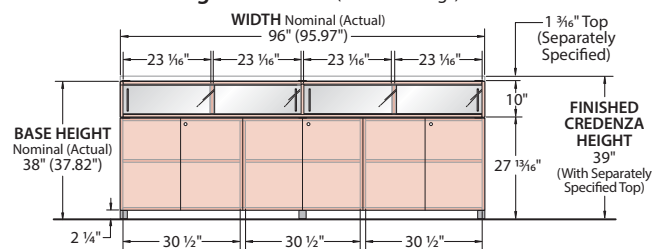

Front View – 39" High x 108" Wide (6 Doors/6 Legs)

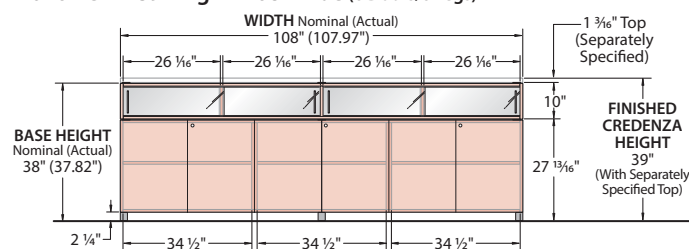

Note The side view dimensions for the 36" wide Credenza are the same for all 39" High Credenzas.

Product Details – Credenzas

Credenza Base with Slider Unit– 45" High

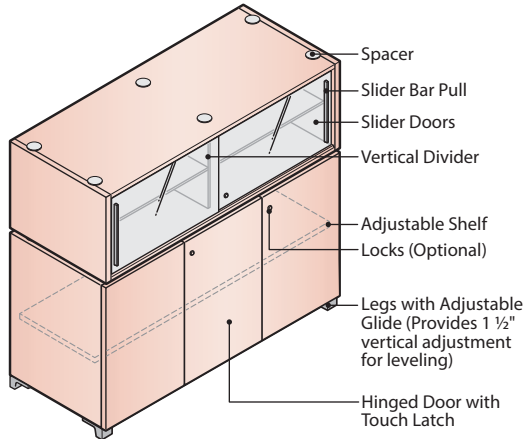

- The 45" High Credenza Base with Slider Unit includes a 16" High Slider Unit attached a 28" High Credenza Base.
- A separately specified Credenza Top is required to finish the top (Specify width of Credenza Top to match width of Credenza).
- Fixed Vertical Dividers are used to sub-divide interior compartments (Exception: 36" wide unit does not include vertical dividers).
- Each interior compartment in the Slider Unit and Credenza Base includes (1) adjustable shelf.

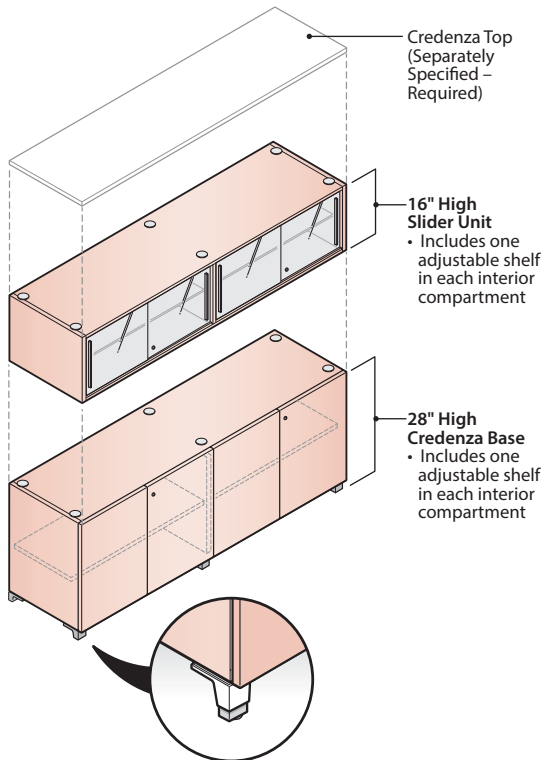

Detail of Credenza Leg

- Painted Metal with Black Glide.
- Leg is 2 1/4" High.
- Glide provides 1 1/2" of vertical adjustment for leveling.

Component Materials/Finishes

COMPONENT NAME	MATERIALS/ FINISHES
Hinged Doors, Tops, Bottoms, Sides, Backs, Shelves and Dividers Include 1mm laminate or wood edgeband.	Laminate – Specify surface color and separate edge color. Wood – Specify surface and edge wood finish color. (Door fronts are matched veneer)
Leg	Painted Aluminum – Specify trim color (matches Slider Bar Pull) Glides – Standard in Black
Slider Bar Pull	Painted Aluminum – Specify trim color (matches Leg)
Slider Doors	Available in Glass or Translucent
Lock (Optional)	Locks are available in Black or Chrome.

45" High Credenza Base with Slider Unit Configurations

- Illustrations show configurations and component quantities.
- Red Arrows show door swing.

36" Wide

- 16" High Slider Unit
- (2) Slider Doors
- (1) Shelf

- 28" High Credenza Base
- (2) Hinged Doors
- (1) Shelf
- (4) Legs

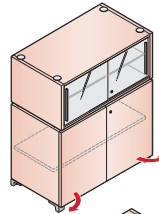

48" Wide

- 16" High Slider Unit
- (2) Slider Doors
- (1) Divider
- (2) Shelves

- 28" High Credenza Base
- (3) Hinged Doors
- (1) Divider
- (2) Shelves
- (4) Legs

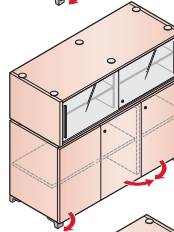

54" Wide

- 16" High Slider Unit
- (2) Slider Doors
- (1) Divider
- (2) Shelves

- 28" High Credenza Base
- (3) Hinged Doors
- (1) Divider
- (2) Shelves
- (4) Legs

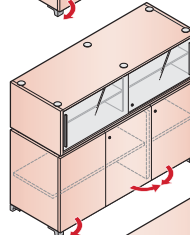

72" Wide

- 16" High Slider Unit
- (4) Slider Doors
- (1) Divider
- (2) Shelves

- 28" High Credenza Base
- (4) Hinged Doors
- (1) Divider
- (2) Shelves
- (6) Legs

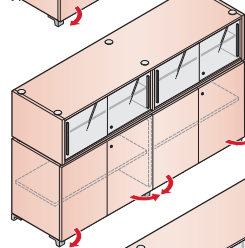

96" Wide

- 16" High Slider Unit
- (4) Slider Doors
- (3) Dividers
- (4) Shelves

- 28" High Credenza Base
- (6) Hinged Doors
- (2) Divider
- (3) Shelves
- (6) Legs

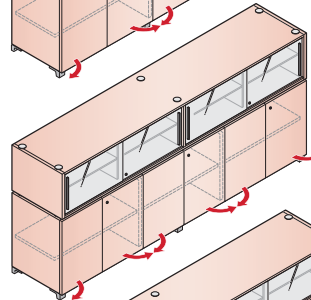

108" Wide

- 16" High Slider Unit
- (4) Slider Doors
- (3) Dividers
- (4) Shelves

- 28" High Credenza Base
- (6) Hinged Doors
- (2) Divider
- (3) Shelves
- (6) Legs

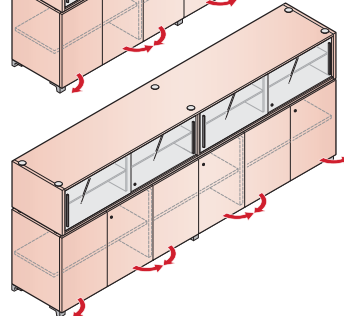

Product Details – Credenzas

Credenza Base with Slider Unit– 45" High

Dimensions

Front View – 45" High x 36" Wide (2 Doors/4 Legs)

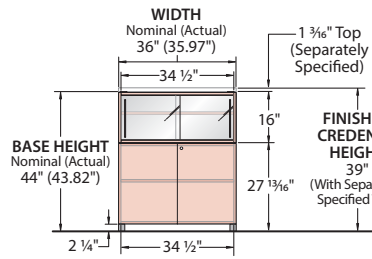

Side View – 45" High Credenza (All Widths)

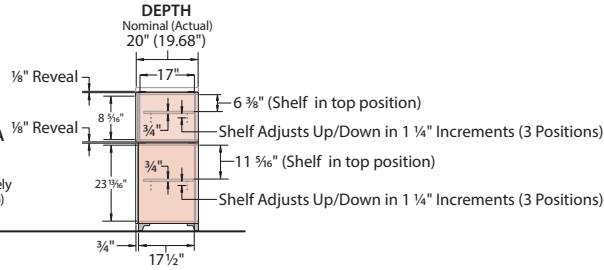

Front View – 45" High x 48" Wide (3 Doors/4 Legs)

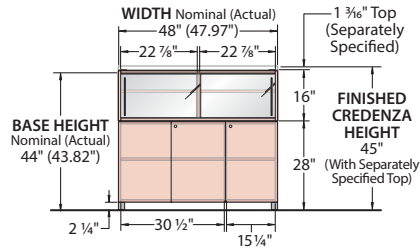

Front View – 45" High x 54" Wide (3 Doors/4 Legs)

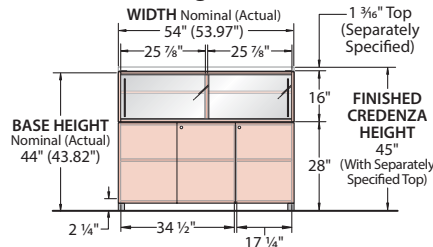

Front View – 45" High x 72" Wide (4 Doors/6 Legs)

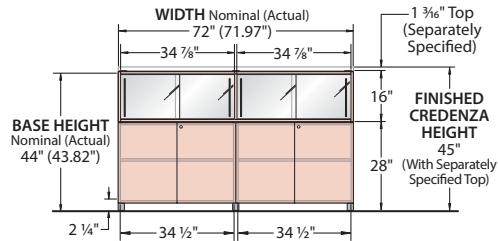

Front View – 45" High x 96" Wide (6 Doors/6 Legs)

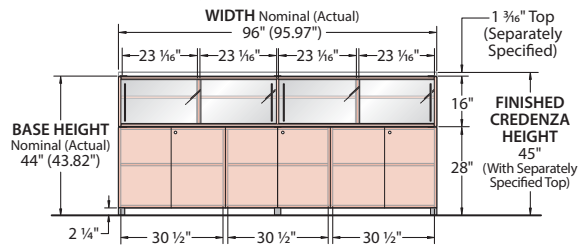

Front View – 45" High x 108" Wide (6 Doors/6 Legs)

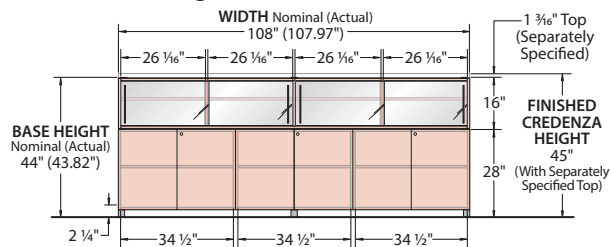

Note The side view dimensions for the 36" wide Credenza are the same for all 45" High Credenzas.

Product Details – Planes Interior Leg Conference Tables

Overview

Interior Leg Conference Tables can be specified with a variety of sizes and shapes to accommodate any conference room and any conferencing style. The rectilinear design of the interior Legs, along with the sleek profile of the top, give the table a clean, contemporary aesthetic.

Table Components

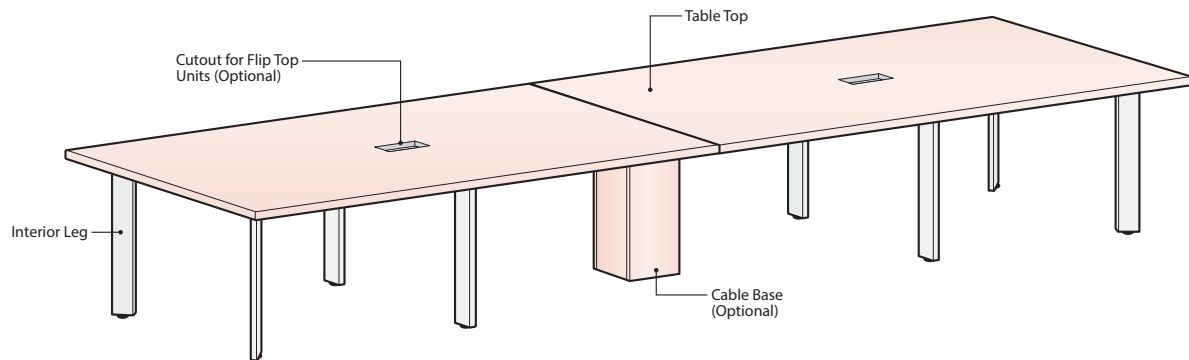

Features

- The rectangular shaped Interior Legs are inset from the edges and the corner legs are turned at a 45° angle.
- Legs are painted aluminum and include an adjustable glide that provides ½" of vertical adjustment for leveling.
- The tops are available in wood or laminate with edgeband or knife edge options.
- Tables may be specified with optional factory cutouts for separately specified Flip Top Units for power.
- Most tables are available with optional Cable Bases for Power Management. Cable Bases may be also be used to support the top and reduce the number of legs needed (If Cable Base is removed during reconfiguration, ensure top is properly supported with legs at each corner and vertical support every 60").
- For additional wire management capabilities the seated height Column Base may be separately specified.

Product Details – Planes Interior Leg Conference Tables

Overview

Edge Options for Laminate Tops

3mm Edgeband Edge (Option J)

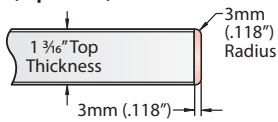

Top View Detail

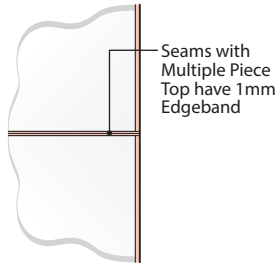

Knife Edge (Option F)

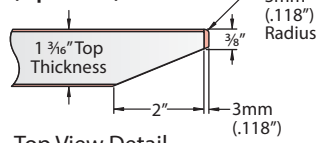

Top View Detail

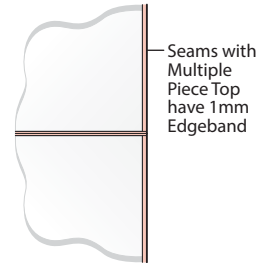

Edge Options for Wood Tops

3mm Edgeband Edge (Option K)

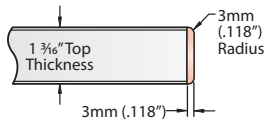

Top View Detail

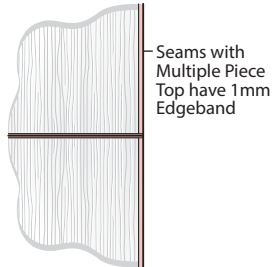

Knife Edge (Option U)

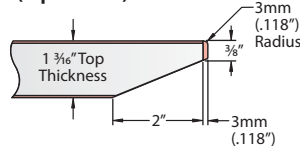

Top View Detail

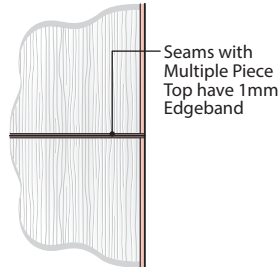

- Note**
- Refer to Price List for edge availability.
 - Multiple piece tops with Cascade edge option will require an additional specification for the 1mm edgeband seam.

Product Details – Planes Interior Leg Conference Tables

Overview

Wood Grain Direction for Natural, Quarter Cut, Rift Cut and Double Cut Wood Veneer

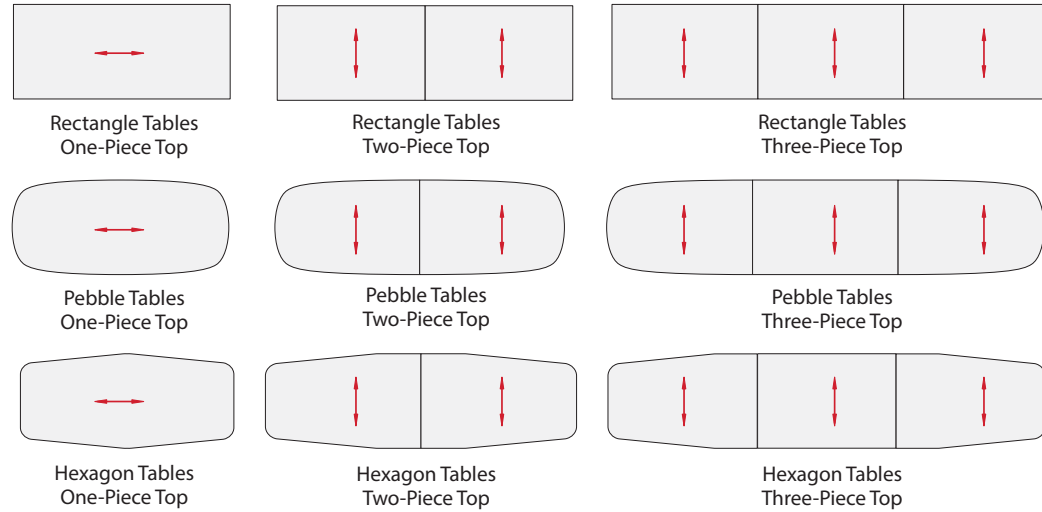
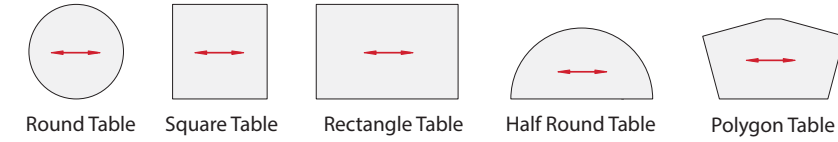
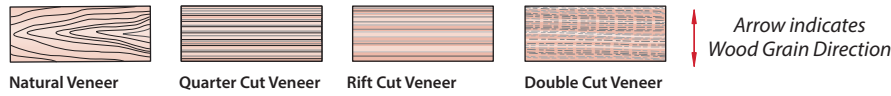

Wood Grain Direction for Wood Grain Laminate

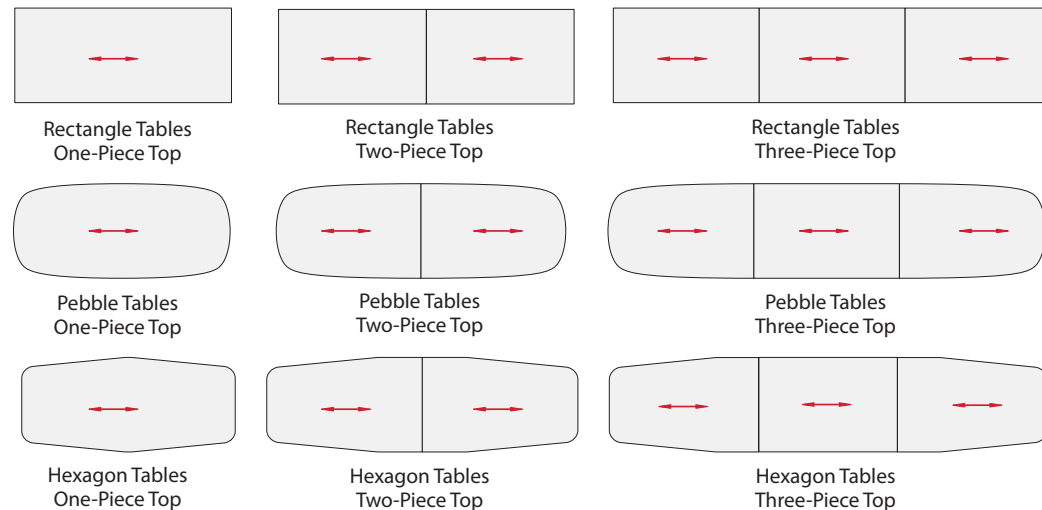
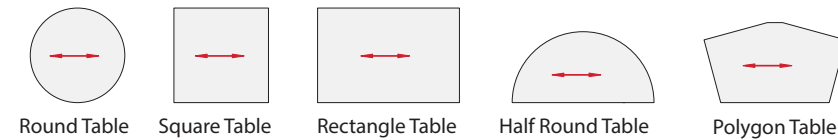

Note Laminate wood grain on multi-piece tops may not match.

Product Details – Planes Interior Leg Conference Tables

Round (One-Piece Top)

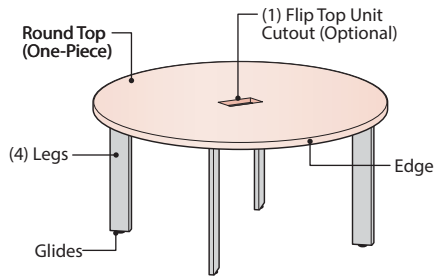

Edge Options for Laminate Tops

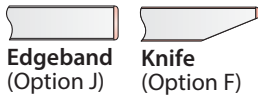

Note Knife Edge or 3mm Edgeband options are not available on 42"-60" round 1-piece Tables.

Edge Options for Wood Tops

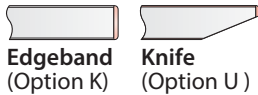

Flip Top Unit Cutout Options

Center Cutout Option
Includes 1 Flip Top Unit cutout (centered on top)

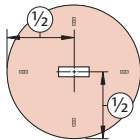

Cutout Option (F)
For use with Single Sided/ 4 Port Flip Top Unit

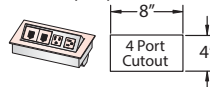

Cutout Option (J)
For use with Single Sided/ 6 Ports Flip Top Unit

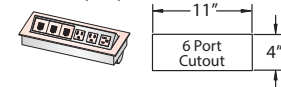

Cutout Option (M)
For use with Double Sided/ 8 Ports Flip Top Unit

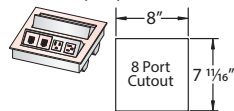

Cutout Option (Q)
For use with Double Sided/ 12 Ports Flip Top Unit

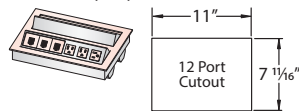

Note

- Flip Top Units are separately specified.
- Cutouts may work with some workware Interface Modules, see workware price book for details.

Component Materials/Finishes

COMPONENT NAME	MATERIALS/ FINISHES
Round Top 1-Piece top	Laminate Top – Specify separate finish colors for top and edge trim • Edge Options: (J) Edgeband, (F) Knife
	Wood Top – Specify a single finish color for the top and edge trim • Edge Options: (K) Edgeband, (U) Knife
Interior Legs	Painted Metal – Specified Trim Color
Glides	Standard in Black

Dimensions

TABLETOP		KNEESPACE (Nominal)	
Diameter Nominal (Actual)	Number of Legs Included	(A)	(B)
42" (41.68")	(4) Legs	21"	19"
48" (47.68")	(4) Legs	24"	24"
54" (53.68")	(4) Legs	27"	28"
60" (59.68")	(4) Legs	30"	32"

Top View

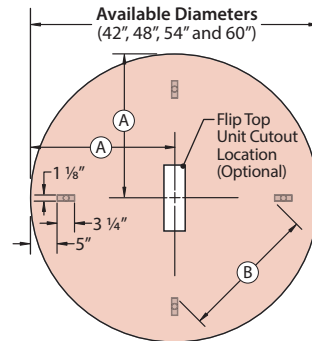

Front View

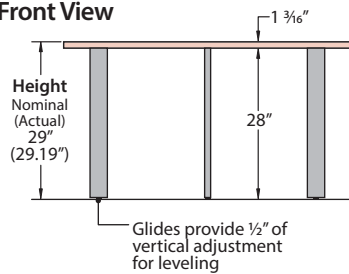
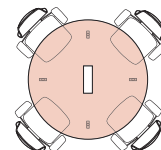

Table Sizes and Seating Capacities

TABLE SIZES	MAXIMUM NUMBER OF CHAIRS
42" Diameter	4 Chairs Maximum (4 Legs)
48" Diameter	4 Chairs Maximum (4 Legs)
54" Diameter	4 Chairs Maximum (4 Legs)
60" Diameter	4 Chairs Maximum (4 Legs)



Note

- Cable Bases are not recommended One-Piece Round Tables, due to lack of kneespace clearance. Consider kneespace when specifying cable management components.
- Recommended seating capacity based upon a width of 27" per chair.

Product Details – Planes Interior Leg Conference Tables

Round (Two-Piece Top)

No Cable Base (Includes 6 Legs)

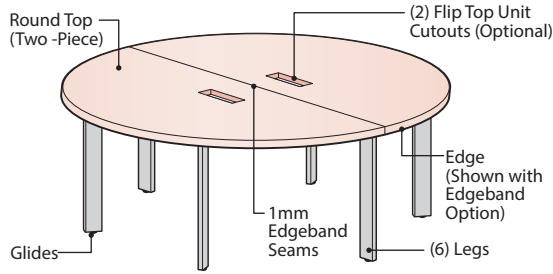

With Cable Base (Includes 4 Legs)

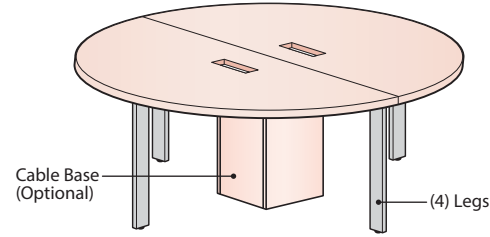

Edge Options for Laminate Tops

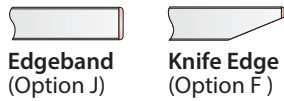

Edge Options for Wood Tops



Flip Top Unit Cutout Options

Center Cutout Locations
Includes 2 Flip Top Unit cutouts (One cutout in each top piece)

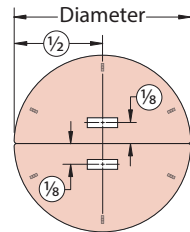

Cutout Option (F)
For use with Single Sided/ 4 Port Flip Top Unit

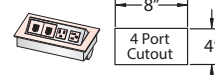

Cutout Option (J)
For use with Single Sided/ 6 Ports Flip Top Unit

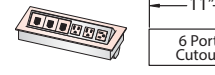

Note

- Double sided flip top units are not recommended with 2-Piece Round Tables.
- Flip Top Units are separately specified.

Cable Base Options

- Two-Piece round tables may be specified with or without Cable Bases
 - (Option N) No Cable Base.
 - (Option C) Cable Base

Cable Base Size and Location

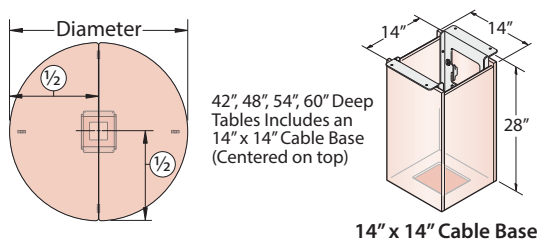

14" x 14" Cable Base

Component Materials/Finishes

COMPONENT NAME	MATERIALS/ FINISHES
Round Top 2-Piece top with 1mm edgeband seams.	Laminate Top – Specify separate finish colors for top and edge trim • Edge Options: (J) Edgeband, (F) Knife Wood Top – Specify a single finish color for the top and edge trim • Edge Options: (K) Edgeband, (U) Knife
Interior Legs	Painted Metal – Specified Trim Color
Cable Base (Optional)	Panels Laminate Panels – Specified surface and edge trim colors Wood Panels – Specified top and edge trim wood finish color
	Frame Painted Metal – Standard in Black
Glides	Standard in Black

Dimensions

TABLETOP Diameter (Width/Depth) Nominal (Actual)	KNEESPACE (Nominal)				
	A	B	C	D	E
66" (65.68")	33"	8 1/4"	24"	19"	37"
72" (71.68")	36"	9"	31"	24"	41"

No Cable Base – Includes (6) Legs

Top View

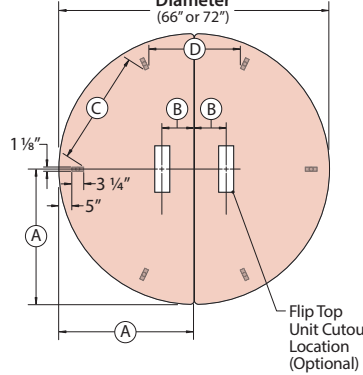

With Cable Base – Includes (4) Legs

Top View

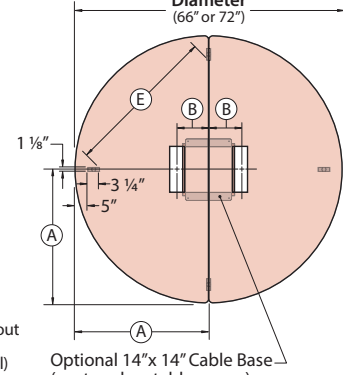

Front View

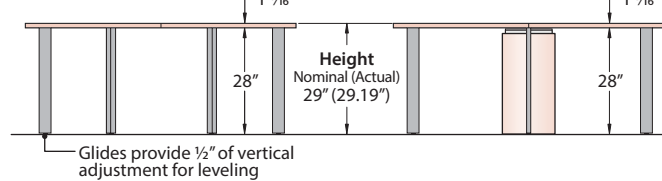

Table Sizes and Seating Capacities – Without Cable Base

TABLE SIZE	MAXIMUM NUMBER OF CHAIRS
66" Diameter	6 Chairs Maximum (6 Legs)
72" Diameter	6 Chairs Maximum (6 Legs)

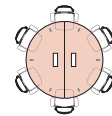
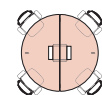

Table Sizes and Seating Capacities – With Cable Base

TABLE SIZE	MAXIMUM NUMBER OF CHAIRS
66" Diameter	4 Chairs Maximum (4 Legs)
72" Diameter	4 Chairs Maximum (4 Legs)



Note Recommended seating capacity based upon a width of 27" per chair.

Product Details – Planes Interior Leg Conference Tables

Square (One-Piece Top)

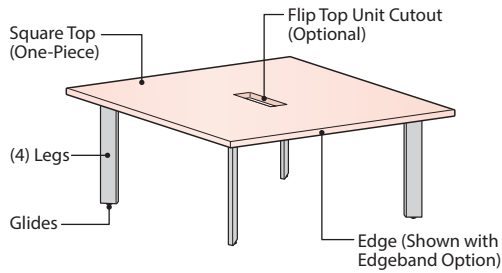

Edge Options for Laminate Tops

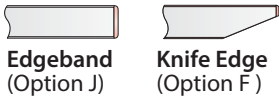

Edge Options for Wood Tops

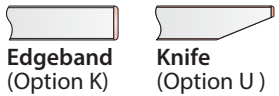

Flip Top Unit Cutout Options

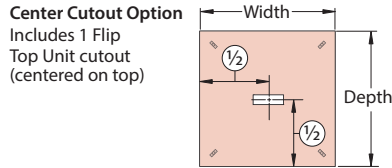

Cutout Option (F or V)
For use with Single Sided/
4 Port Flip Top Unit

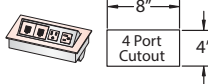

Cutout Option (J or K)
For use with Single Sided/
6 Ports Flip Top Unit

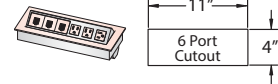

Cutout Option (M or P)
For use with Double Sided/
8 Ports Flip Top Unit

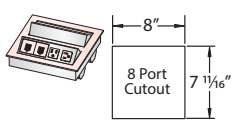

Cutout Option (Q or T)
For use with Double Sided/
12 Ports Flip Top Unit

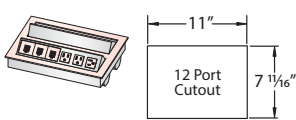

Note Flip Top Units are separately specified.

Component Materials/Finishes

COMPONENT NAME	MATERIALS/ FINISHES
Round Top 1-Piece top.	Laminate Top – Specify separate finish colors for top and edge trim • Edge Options: (J) Edgeband, (F) Knife
	Wood Top – Specify a single finish color for the top and edge trim • Edge Options: (K) Edgeband, (U) Knife
Interior Legs	Painted Metal – Specified Trim Color
Glides	Standard in Black

Dimensions

TABLETOP			KNEESPACE (Nominal)
Width Nominal (Actual)	Depth Nominal (Actual)	(A)	(B)
42" (41.68")	42" (41.68")	21"	27"
48" (47.68")	48" (47.68")	24"	33"
54" (53.68")	54" (53.68")	27"	39"
60" (59.68")	60" (59.68")	30"	45"

Top View

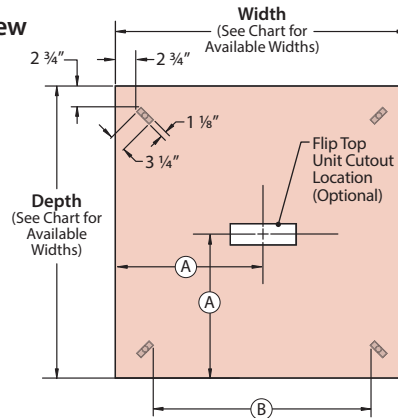

Front View

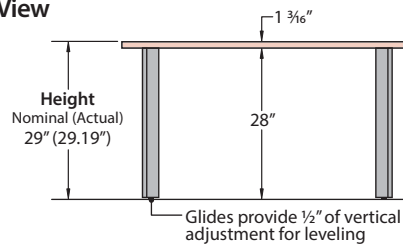

Table Sizes and Seating Capacities

TABLE SIZES		MAXIMUM NUMBER OF CHAIRS	
Depth	Wide		
42" Deep	42" Wide	4 Chairs Maximum (4 Legs)	
48" Deep	48" Wide	4 Chairs Maximum (4 Legs)	
54" Deep	54" Wide	4 Chairs Maximum (4 Legs)	
60" Deep	60" Wide	8 Chairs Maximum (4 Legs)	

Note • Recommended seating capacity based upon a width of 27" per chair.
• Cable Bases are not recommended for One-Piece Square Tables, due to lack of kneespace clearance. Consider the separately specified Cable Column for cable management.

Product Details – Planes Interior Leg Conference Tables

Square (Two-Piece Top)

No Cable Base (Includes 6 Legs)

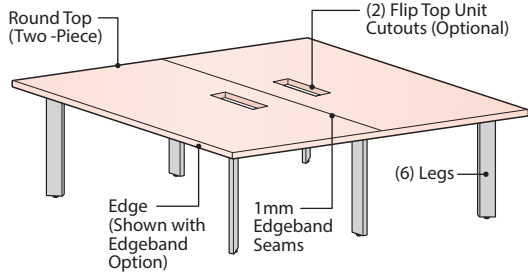

With Cable Base (Includes 4 Legs)

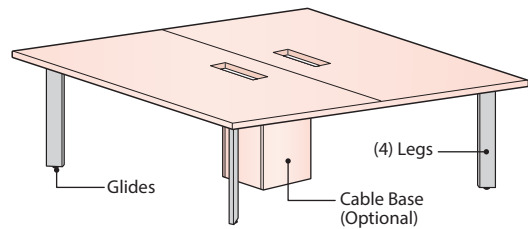

Edge Options for Laminate Tops

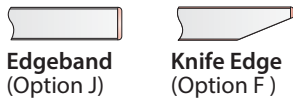

Edge Options for Wood Tops



Flip Top Unit Cutout Options

Center Cutout Locations
Includes 2 Flip Top Unit cutouts (One cutout in each top piece)

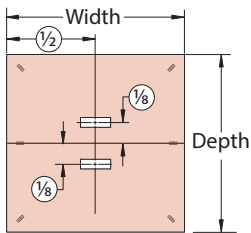

Cutout Option (F)
For use with Single Sided/4 Port

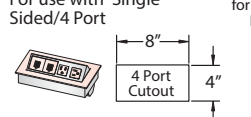

Cutout Option (J)
For use with Single Sided / 6 Ports Flip Top Unit

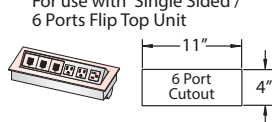

Note • Double sided flip top units are not recommended with 2-Piece Round Tables.
• Flip Top Units are separately specified.

Cable Base Options

- Two-Piece round tables may be specified with or without Cable Bases
 - (Option N) No Cable Base.
 - (Option C) Cable Base

Cable Base Size and Location

42", 48", 54", 60" Deep Tables Includes a 14" x 14" Cable Base (Centered on top)

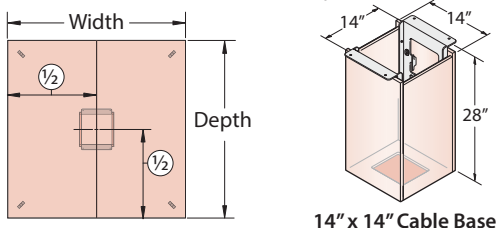

14" x 14" Cable Base

Component Materials/Finishes

COMPONENT NAME	MATERIALS/ FINISHES
Square Top 2-Piece top with 1mm edgeband seams.	Laminate Top – Specify separate finish colors for top and edge trim • Edge Options: (J) Edgeband, (F) Knife
	Wood Top – Specify a single finish color for the top and edge trim • Edge Options: (K) Edgeband, (U) Knife
Interior Legs	Painted Metal – Specified Trim Color
Cable Base (Optional)	Panels Laminate Panels – Specified surface and edge trim colors Wood Panels – Specified top and edge trim wood finish color
	Frame Painted Metal – Standard in Black
Glides	Standard in Black

Dimensions

Diameter (Width/Depth) Nominal (Actual)	TABLETOP		KNEESPACE (Nominal)	
	A	B	C	D
66" (65.68")	33"	8 1/4"	51"	25"
72" (71.68")	36"	9"	57"	28"

No Cable Base – Includes (6) Legs
Top View

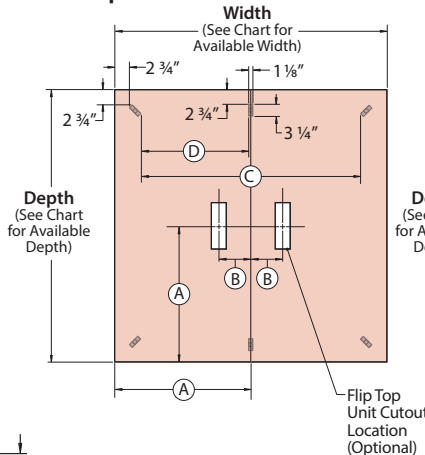

Front View

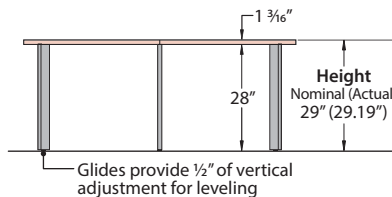

With Cable Base – Includes (4) Legs
Top View

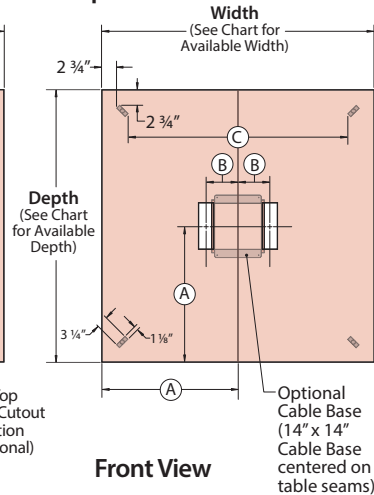

Front View

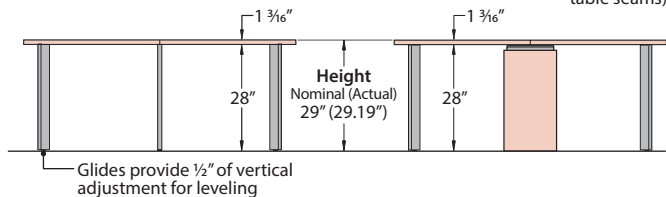

Table Sizes and Seating Capacities

TABLE SIZE	MAXIMUM NUMBER OF CHAIRS
With or Without Cable Base	8 Chairs Maximum
66" Wide/ 66" Deep	
72" Wide/ 72" Deep	

Note • Recommended seating capacity based upon a width of 27" per chair.

Product Details – Planes Interior Leg Conference Tables

Rectangular

48"/54"/60"/66" Wide – Without Cable Base
Includes (4) Legs

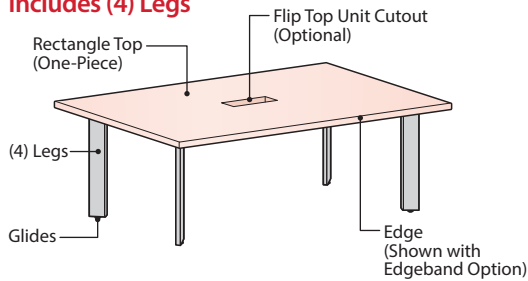

48"/54"/60"/66" Wide – With Cable Base
Includes (4) Legs

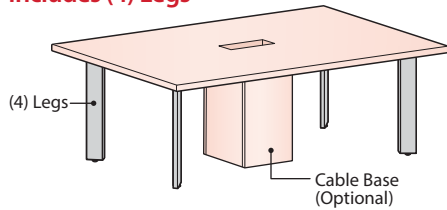

72"/78" Wide – Without Cable Base
Includes (6) Legs

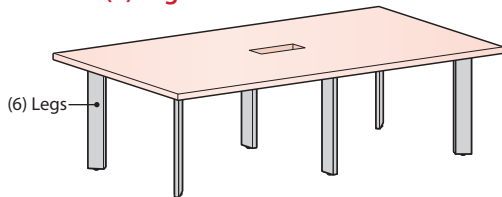

72"/78" Wide – With Cable Base
Includes (4) Legs

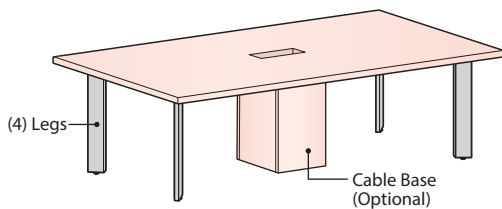

Edge Options for Laminate Tops

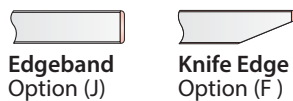

Edge Options for Wood Tops

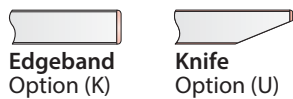

Component Materials/Finishes

COMPONENT NAME	MATERIALS/ FINISHES
Rectangle Top 1-Piece top	Laminate Top – Specify separate finish colors for top and edge trim • Edge Options: (T) T-Mold, (J) Edgeband, (V) Cascade, (F) Knife
	Wood Top – Specify a single finish color for the top and edge trim • Edge Options: (K) Edgeband, (M) Cascade*, (U) Knife
Interior Legs	Painted Metal – Specified Trim Color
Glides	Standard in Black
Cable Base (Optional)	Panels Laminate Panels – Specified surface and edge trim colors Wood Panels – Specified top and edge trim wood finish color
	Frame Painted Metal – Standard in Black

Flip Top Unit Cutout Options

Center Cutout Option

- Includes 1 Flip Top Unit cutout (centered on top)

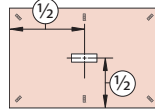

Left/Right Cutout Option

- Includes 2 Flip Top Unit cutouts (1 Left Cutout and 1 Right Cutout)

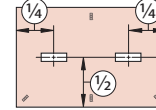

Cutout Option (F or V)

- For use with Single Sided/ 4 Port Flip Top Unit

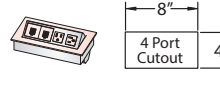

Cutout Option (J or K)

- For use with Single Sided/ 6 Ports Flip Top Unit

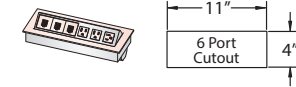

Cutout Option (M or P)

- For use with Double Sided/ 8 Ports Flip Top Unit

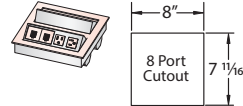

Cutout Option (Q or T)

- For use with Double Sided/ 12 Ports Flip Top Unit

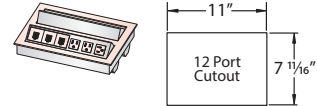

Note Flip Top Units are separately specified.

Cable Base Options

- Tables may be specified with or without Cable Bases
 - (Option N) No Cable Base.
 - (Option C) Cable Base

One-Piece Table with Cable Base option (Top View)

36" Deep Table
Includes an 8" x 14" Cable Base (Centered on top)

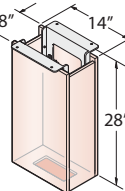
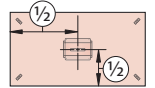

8" x 14" Cable Base

42", 48", 54", 60" Deep
Tables Includes an 8" x 14" Cable Base (Centered on top)

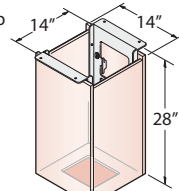
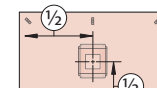

14" x 14" Cable Base

- Note**
- Cable Base option not recommended for 30" deep tables.
 - Cable base and table tops may be specified with different surface colors and edge trim colors.

Product Details – Planes Interior Leg Conference Tables

Rectangular

48"/54"/60"/66" Wide – Without Cable Base (Includes 4 Legs)

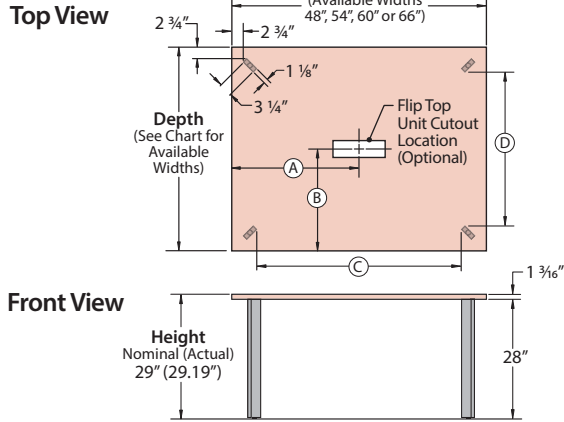

72"/78" Wide – Without Cable Base (Includes 6 Legs)

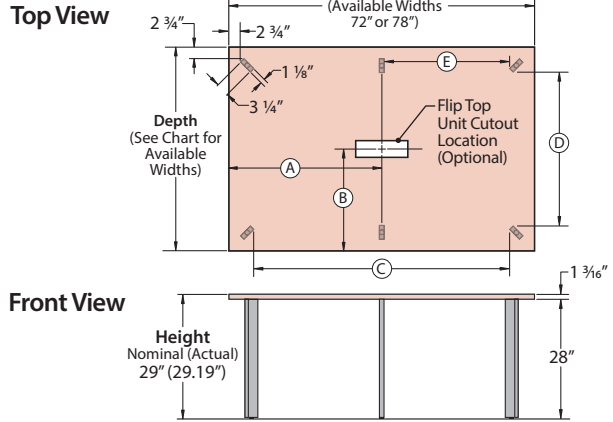

48"/54"/60"/66" Wide – With Cable Base (Includes 4 Legs)

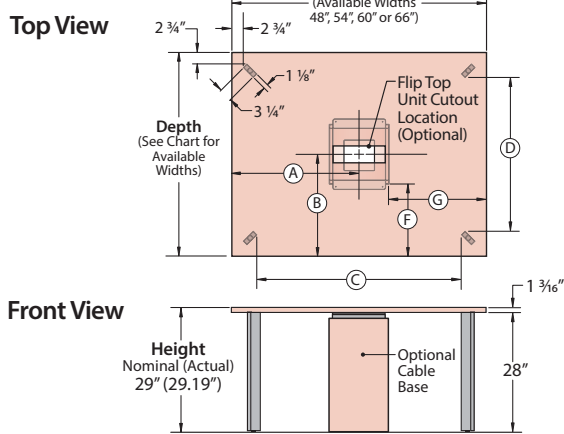

72"/78" Wide – With Cable Base (Includes 4 Legs)

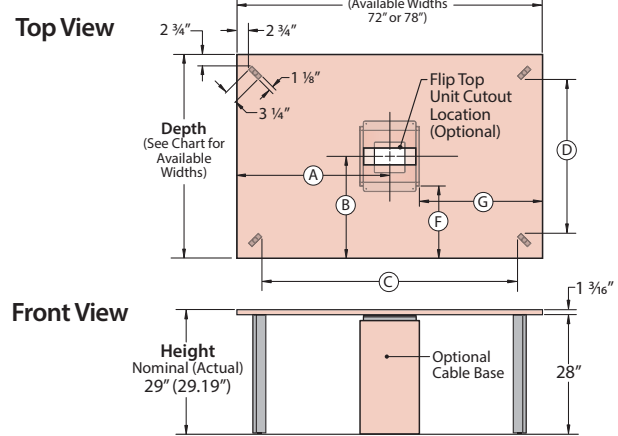

Note The optional Cable Base reduces the number of legs shipped with 72" and 78" Wide Tables to (4) legs.

Dimensions

TABLETOP					KNEESPACE (Nominal)					CABLE BASE		
Depth Nominal (Actual)	Width Nominal (Actual)	Number of Top Pieces	A	B	C	D	E	F	G	Optional Cable Base Size/ Availability	Number of Legs Without Cable Base	Number of Legs With Cable Base
30" (29.68")	60" (59.68")	1	30"	15"	45"	15"	N/A	N/A	N/A	N/A	4	N/A
	66" (65.68")	1	33"	15"	51"	15"	N/A	N/A	N/A	N/A	4	N/A
36" (35.68")	72" (71.68")	1	36"	15"	57"	15"	28"	N/A	N/A	N/A	6	N/A
	60" (59.68")	1	30"	16"	45"	21"	N/A	14"	23"	8" D x 14"W	4	4
42" (41.68")	66" (65.68")	1	33"	16"	51"	21"	N/A	14"	26"	8" D x 14"W	4	4
	48" (47.68")	1	24"	21"	33"	27"	N/A	14"	17"	14" D x 14"W	4	4
	54" (53.68")	1	27"	21"	39"	27"	N/A	14"	20"	14" D x 14"W	4	4
	60" (59.68")	1	30"	21"	45"	27"	N/A	14"	23"	14" D x 14"W	4	4
	66" (65.68")	1	33"	21"	51"	27"	N/A	14"	26"	14" D x 14"W	4	4
	72" (71.68")	1	36"	21"	57"	27"	28"	14"	29"	14" D x 14"W	6	4
	78" (77.68")	1	39"	21"	63"	27"	31"	14"	32"	14" D x 14"W	6	4
48" (47.68")	54" (53.68")	1	27"	24"	39"	33"	N/A	17"	20"	14" D x 14"W	4	4
	60" (59.68")	1	30"	24"	45"	33"	N/A	17"	23"	14" D x 14"W	4	4
	66" (65.68")	1	33"	24"	51"	33"	N/A	17"	26"	14" D x 14"W	4	4
	72" (71.68")	1	36"	24"	57"	33"	28"	17"	29"	14" D x 14"W	6	4
54" (53.68")	78" (77.68")	1	39"	24"	63"	33"	31"	17"	32"	14" D x 14"W	6	4
	60" (59.68")	1	30"	27"	45"	39"	N/A	20"	23"	14" D x 14"W	4	4
	66" (65.68")	1	33"	27"	51"	39"	N/A	20"	26"	14" D x 14"W	4	4
	72" (71.68")	1	36"	27"	57"	39"	28"	20"	29"	14" D x 14"W	6	4
60" (59.68")	78" (77.68")	1	39"	27"	63"	39"	31"	20"	32"	14" D x 14"W	6	4
	66" (65.68")	1	33"	30"	51"	45"	N/A	23"	26"	14" D x 14"W	4	4
	72" (71.68")	1	36"	30"	57"	45"	28"	23"	29"	14" D x 14"W	6	4
60" (59.68")	78" (77.68")	1	39"	30"	63"	45"	31"	23"	32"	14" D x 14"W	6	4

Note

- For optional Flip Top Unit Cutout sizes and dimensions see previous page.
- 36" tables are available with 8"D x 16"W Cable Bases, which are not compatible with Double Sided Flip Top Unit Cutouts (M) or (Q).
- Cable Base option not recommended for 30" deep tables, consider the separately specified Cable Column for cable management.

Product Details – Planes Interior Leg Conference Tables

Rectangular

Table Sizes and Seating Capacities – Without Cable Bases

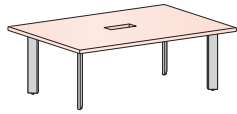

48"-66" wide Rectangle Tables specified without a Cable Base are standard with 4 Legs.

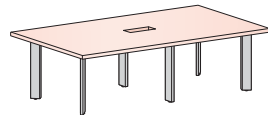

72"-78" wide Rectangle Tables specified without a Cable Base are standard with 6 Legs.

		WIDTHS					
		48" Wide	54" Wide	60" Wide	66" Wide	72" Wide	78" Wide
DEPTHS	30" Deep			6 Chairs Max. (4 Legs)	6 Chairs Max. (4 Legs)	6 Chairs Max. (6 Legs)	
	36" Deep			6 Chairs Max. (4 Legs)	6 Chairs Max. (4 Legs)		
	42" Deep	4 Chairs Max. (4 Legs)	4 Chairs Max. (4 Legs)	6 Chairs Max. (4 Legs)	6 Chairs Max. (4 Legs)	6 Chairs Max. (6 Legs)	6 Chairs Max. (6 Legs)
	48" Deep		4 Chairs Max. (4 Legs)	6 Chairs Max. (4 Legs)	6 Chairs Max. (4 Legs)	6 Chairs Max. (6 Legs)	6 Chairs Max. (6 Legs)
	54" Deep			6 Chairs Max. (6 Legs)	6 Chairs Max. (4 Legs)	6 Chairs Max. (6 Legs)	6 Chairs Max. (6 Legs)
	60" Deep				8 Chairs Max. (4 Legs)	8 Chairs Max. (6 Legs)	8 Chairs Max. (6 Legs)

Table Sizes and Seating Capacities – With Cable Bases

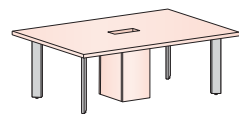

48"-66" wide Rectangle Tables specified without a Cable Base are standard with 4 Legs.

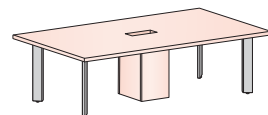

72"-78" wide Rectangle Tables specified without a Cable Base are standard with 4 Legs.

		WIDTHS					
		48" Wide	54" Wide	60" Wide	66" Wide	72" Wide	78" Wide
DEPTHS	30" Deep			Cable Base Not Recommended	Cable Base Not Recommended	Cable Base Not Recommended	
	36" Deep			6 Chairs Max. (4) Legs/ (1) 8"x14" Cable Base	6 Chairs Max. (4) Legs/ (1) 8"x14" Cable Base		
	42" Deep	4 Chairs Max. (4) Legs/ (1) 14"x14" Cable Base	4 Chairs Max. (4) Legs/ (1) 14"x14" Cable Base	6 Chairs Max. (4) Legs/ (1) 14"x14" Cable Base	6 Chairs Max. (4) Legs/ (1) 14"x14" Cable Base	6 Chairs Max. (4) Legs/ (1) 14"x14" Cable Base	6 Chairs Max. (4) Legs/ (1) 14"x14" Cable Base
	48" Deep		4 Chairs Max. (4) Legs/ (1) 14"x14" Cable Base	6 Chairs Max. (4) Legs/ (1) 14"x14" Cable Base	6 Chairs Max. (4) Legs/ (1) 14"x14" Cable Base	6 Chairs Max. (4) Legs/ (1) 14"x14" Cable Base	6 Chairs Max. (4) Legs/ (1) 14"x14" Cable Base
	54" Deep			6 Chairs Max. (4) Legs/ (1) 14"x14" Cable Base	6 Chairs Max. (4) Legs/ (1) 14"x14" Cable Base	6 Chairs Max. (4) Legs/ (1) 14"x14" Cable Base	6 Chairs Max. (4) Legs/ (1) 14"x14" Cable Base
	60" Deep				8 Chairs Max. (4) Legs/ (1) 14"x14" Cable Base	8 Chairs Max. (4) Legs/ (1) 14"x14" Cable Base	8 Chairs Max. (4) Legs/ (1) 14"x14" Cable Base

Note • Recommended seating capacity based upon a width of 27" per chair.

Product Details – Planes Interior Leg Conference Tables

Half Round

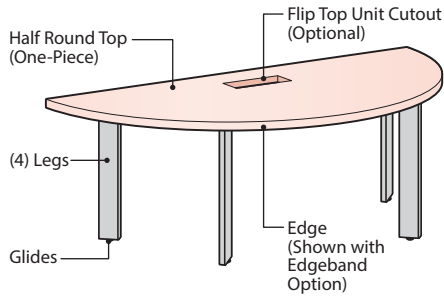

Edge Options for Laminate Tops

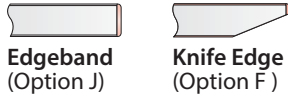

Edge Options for Wood Tops



Flip Top Unit Cutout Options

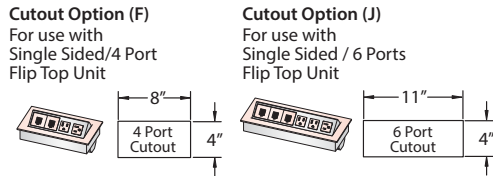

- Note**
- Double sided flip top units are not recommended for use with Half Round Tables.
 - Flip Top Units are separately specified.

Table Sizes and Seating Capacities

		WIDTHS	
		60" Wide	72" Wide
DEPTH	30" Deep	<p>5 Chairs Maximum (Includes 4 Legs)</p>	N/A
	36" Deep	N/A	<p>5 Chairs Maximum (Includes 4 Legs)</p>

- Note**
- Recommended seating capacity based upon a width of 27" per chair.
 - Cable Bases are not recommended for Half Round Tables, due to lack of kneespace clearance. Consider the separately specified Cable Column for cable management.

Component Materials/Finishes

COMPONENT NAME	MATERIALS/ FINISHES
Half Round Top (1-Piece top)	Laminate Top – Specify separate finish colors for top and edge trim • Edge Options: (J) Edgeband, (F) Knife
	Wood Top – Specify a single finish color for the top and edge trim • Edge Options: (K) Edgeband, (U) Knife
Interior Legs	Painted Metal – Specified Trim Color
Glides	Standard in Black

Dimensions

TABLETOP				KNEESPACE		
Width Nominal (Actual)	Depth Nominal (Actual)	(A)	(B)	(C)	(D)	(E)
60" (59.68")	30" (29.68")	30"	15"	19"	19"	45"
72" (71.68")	36" (35.68")	36"	18"	24"	25"	57"

Top View

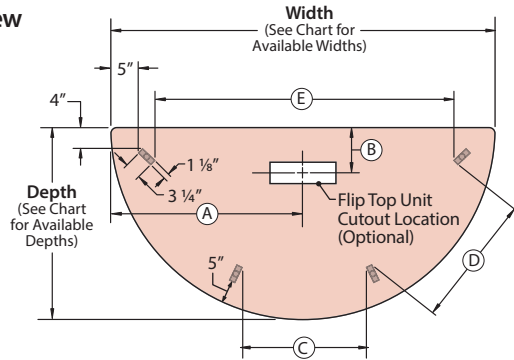

Front View

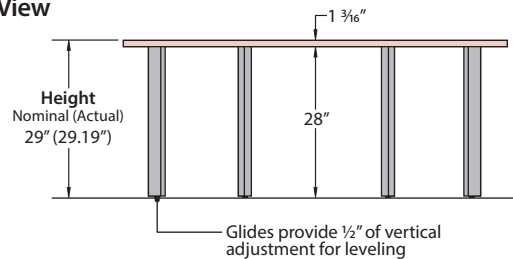

Product Details – Planes Interior Leg Conference Tables

Polygon

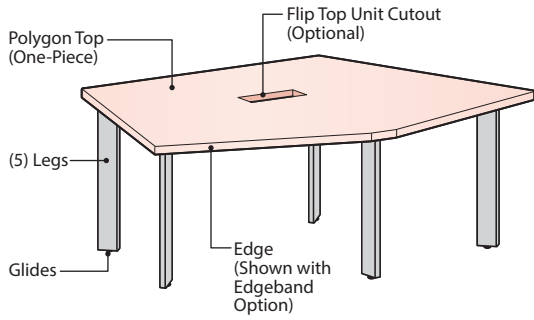

Edge Options for Laminate Tops



Edge Options for Wood Tops



Flip Top Unit Cutout Options

Cutout Option (F)
For use with Single Sided / 4 Port Flip Top Unit

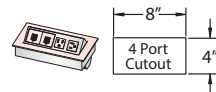

Cutout Option (J)
For use with Single Sided / 6 Ports Flip Top Unit

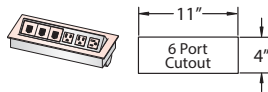

- Note**
- Double sided flip top units are not recommended for use with Polygon Tables.
 - Flip Top Units are separately specified.

Table Sizes and Seating Capacities

		WIDTHS	
		60" Wide	72" Wide
DEPTHS	30" Deep	 5 Chairs Maximum (Includes 5 Legs)	N/A
	36" Deep	N/A	 6 Chairs Maximum (Includes 5 Legs)

- Note**
- Recommended seating capacity based upon a width of 27" per chair.
 - Cable Bases are not recommended for Polygon Tables, due to lack of kneespace clearance. Consider the separately specified Cable Column for cable management.

Component Materials/Finishes

COMPONENT NAME	MATERIALS/ FINISHES
Polygon Top (1-Piece top)	Laminate Top – Specify separate finish colors for top and edge trim • Edge Options: (J) Edgeband, (F) Knife
	Wood Top – Specify a single finish color for the top and edge trim • Edge Options: (K) Edgeband, (U) Wood
Interior Legs	Painted Metal – Specified Trim Color
Glides	Standard in Black

Dimensions

TABLETOP							KNEESPACE			
Width Nominal (Actual)	Depth Nominal (Actual)	(A)	(B)	(C)	(D)	(E)	(F)	(G)	(H)	(I)
60" (65.84")	30" (29.68")	50 1/2"	29 1/16"	36 9/16"	8 1/2"	32 1/16"	18 1/4"	39"	17"	24"
72" (77.43")	36" (35.68")	58 1/16"	35 1/16"	43 7/8"	8 1/2"	38 3/4"	21 1/16"	47"	23"	30"

Top View

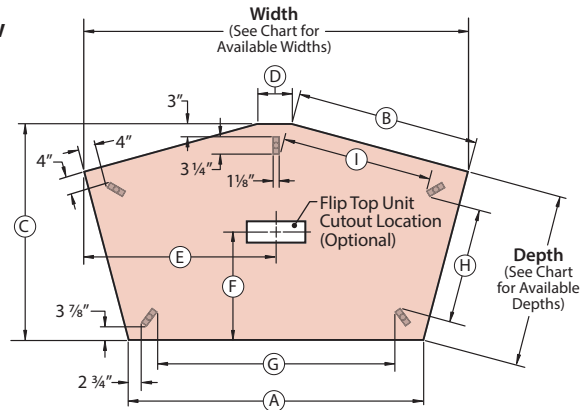

Front View

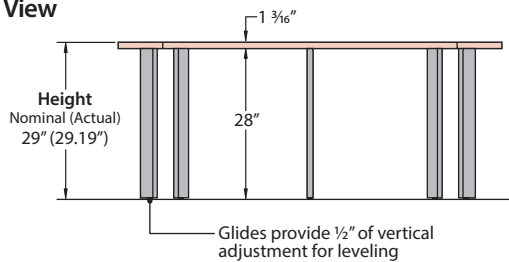

Product Details – Planes Interior Leg Conference Tables

Rectangular (One-Piece Top)

Without Cable Base – Includes (6) Legs

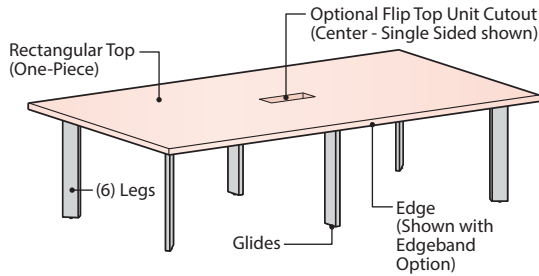

With Cable Base – Includes (4) Legs

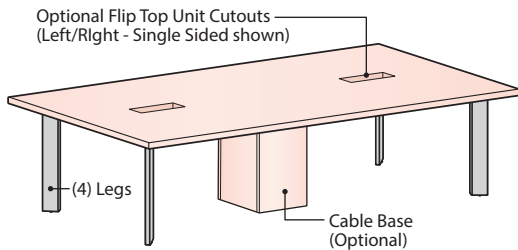

Edge Options for Laminate Tops



Edgeband Option (J)



Knife Edge Option (F)

Edge Options for Wood Tops



Edgeband Option (K)



Knife Option (U)

Component Materials/Finishes

COMPONENT NAME	MATERIALS/ FINISHES
Rectangle Top 1-Piece top	Laminate Top – Specify separate finish colors for top and edge trim • Edge Options: (J) Edgeband, (F) Knife
	Wood Top – Specify a single finish color for the top and edge trim • Edge Options: (K) Edgeband, (U) Knife
Interior Legs	Painted Metal – Specified Trim Color
Glides	Standard in Black
Cable Base (Optional)	Panels Laminate Panels – Specified surface and edge trim colors
	Wood Panels – Specified top and edge trim wood finish color
Frame	Painted Metal – Standard in Black

Flip Top Unit Cutout Options

Center Cutout Option

- Includes 1 Flip Top Unit cutout (centered on top)

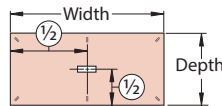

Left/Right Cutout Option

- Includes 2 Flip Top Unit cutouts (1 Left Cutout and 1 Right Cutout)

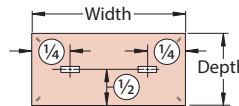

Cutout Option (F or V)

- For use with Single Sided/ 4 Port Flip Top Unit

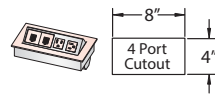

Cutout Option (J or K)

- For use with Single Sided/ 6 Ports Flip Top Unit

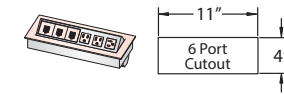

Cutout Option (M or P)

- For use with Double Sided/ 8 Ports Flip Top Unit

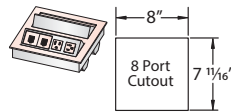

Cutout Option (Q or T)

- For use with Double Sided/ 12 Ports Flip Top Unit

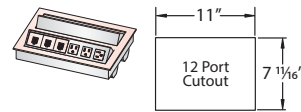

Note Flip Top Units are separately specified.

Cable Base Options

- Tables may be specified with or without Cable Bases
 - (Option N) No Cable Base.
 - (Option C) 36" deep – Includes 8" x 14" Cable Bases
 - 42", 48", 54" and 60" deep – Includes 14" x 14" Cable Bases

One-Piece Table with Cable Base option (Top View)

36" Deep Table
Includes an
8" x 14" Cable Base
(Centered on top)

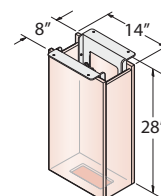
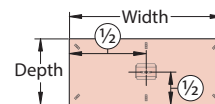

8" x 14"
Cable Base

42", 48", 54", 60" Deep
Tables Includes an
8" x 14" Cable Base
(Centered on top)

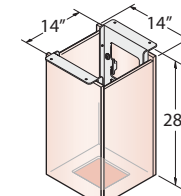
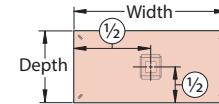

14" x 14"
Cable Base

Product Details – Planes Interior Leg Conference Tables

Rectangular (One-Piece Top)

Dimensions – Without Cable Base – Includes (6) Legs

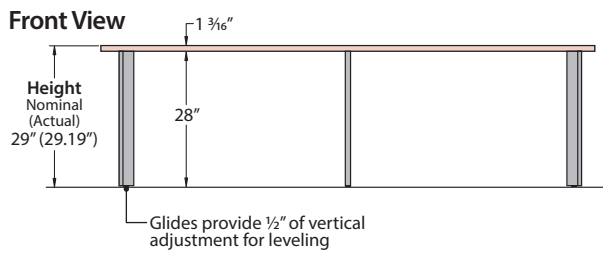
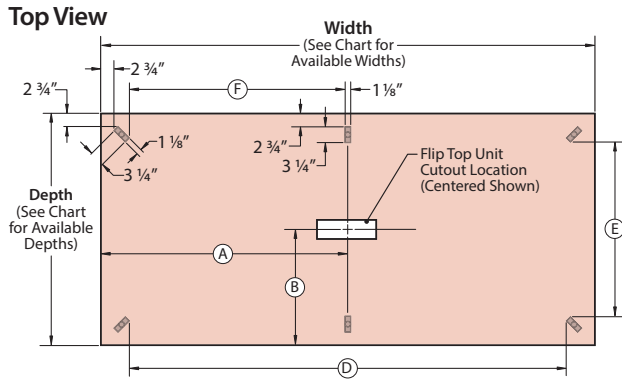

Dimensions – With Cable Base – Includes (4) Legs

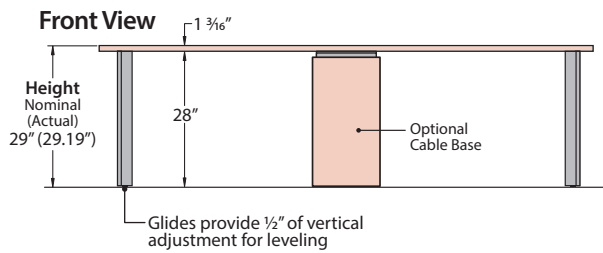
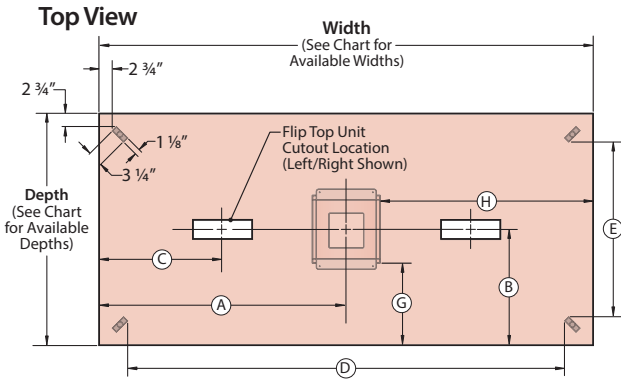

Dimensions

TABLETOP			KNEESPACE (Nominal)			LEGS		CABLE BASE					
Depth Nominal (Actual)	Width Nominal (Actual)	Number of Top Pieces	A	B	C	D	E	F	Number of Legs Without Cable Base	Number of Legs With Cable Base	Optional Cable Base Sizes	G	H
36" (35.68")	72" (71.68")	1	36"	18"	18"	57"	21"	28"	6	4	8" D x 14" W	14"	29"
	78" (77.68")	1	39"	18"	19 1/2"	63"	21"	31"	6	4	8" D x 14" W	14"	32"
	84" (83.68")	1	42"	18"	21"	69"	21"	34"	6	4	8" D x 14" W	14"	35"
	90" (89.68")	1	45"	18"	22 1/2"	75"	21"	37"	6	4	8" D x 14" W	14"	38"
42" (41.68")	96" (95.68")	1	48"	18"	24"	81"	21"	40"	6	4	8" D x 14" W	14"	41"
	84" (83.68")	1	42"	21"	21"	69"	27"	34"	6	4	14" D x 14" W	14"	32"
	90" (89.68")	1	45"	21"	22 1/2"	75"	27"	37"	6	4	14" D x 14" W	14"	35"
	96" (95.68")	1	48"	21"	24"	81"	27"	40"	6	4	14" D x 14" W	14"	38"
	102" (101.68")	1	51"	21"	25 1/2"	87"	27"	43"	6	4	14" D x 14" W	14"	41"
	108" (107.68")	1	54"	21"	27"	93"	27"	46"	6	4	14" D x 14" W	14"	47"
48" (47.68")	114" (113.68")	1	57"	21"	28 1/2"	99"	27"	49"	6	4	14" D x 14" W	14"	50"
	120" (119.68")	1	60"	21"	30"	105"	27"	52"	6	4	14" D x 14" W	14"	53"
	84" (83.68")	1	42"	24"	21"	69"	33"	34"	6	4	14" D x 14" W	17"	32"
	90" (89.68")	1	45"	24"	22 1/2"	75"	33"	37"	6	4	14" D x 14" W	17"	35"
	96" (95.68")	1	48"	24"	24"	81"	33"	40"	6	4	14" D x 14" W	17"	38"
	102" (101.68")	1	51"	24"	25 1/2"	87"	33"	43"	6	4	14" D x 14" W	17"	41"
54" (53.68")	108" (107.68")	1	54"	24"	27"	93"	33"	46"	6	4	14" D x 14" W	17"	47"
	114" (113.68")	1	57"	24"	28 1/2"	99"	33"	49"	6	4	14" D x 14" W	17"	50"
	120" (119.68")	1	60"	24"	30"	105"	33"	52"	6	4	14" D x 14" W	17"	53"
	84" (83.68")	1	42"	27"	21"	69"	39"	34"	6	4	14" D x 14" W	20"	32"
	90" (89.68")	1	45"	27"	22 1/2"	75"	39"	37"	6	4	14" D x 14" W	20"	35"
	96" (95.68")	1	48"	27"	24"	81"	39"	40"	6	4	14" D x 14" W	20"	38"
60" (59.68")	102" (101.68")	1	51"	27"	25 1/2"	87"	39"	43"	6	4	14" D x 14" W	20"	41"
	108" (107.68")	1	54"	27"	27"	93"	39"	46"	6	4	14" D x 14" W	20"	47"
	114" (113.68")	1	57"	27"	28 1/2"	99"	39"	49"	6	4	14" D x 14" W	20"	50"
	120" (119.68")	1	60"	27"	30"	105"	39"	52"	6	4	14" D x 14" W	20"	53"
	84" (83.68")	1	42"	30"	21"	69"	45"	34"	6	4	14" D x 14" W	23"	32"
	90" (89.68")	1	45"	30"	22 1/2"	75"	45"	37"	6	4	14" D x 14" W	23"	35"
60" (59.68")	96" (95.68")	1	48"	30"	24"	81"	45"	40"	6	4	14" D x 14" W	23"	38"
	102" (101.68")	1	51"	30"	25 1/2"	87"	45"	43"	6	4	14" D x 14" W	23"	41"
	108" (107.68")	1	54"	30"	27"	93"	45"	46"	6	4	14" D x 14" W	23"	47"
	114" (113.68")	1	57"	30"	28 1/2"	99"	45"	49"	6	4	14" D x 14" W	23"	50"
	120" (119.68")	1	60"	30"	30"	105"	45"	52"	6	4	14" D x 14" W	23"	53"

Product Details – Planes Interior Leg Conference Tables

Rectangular (One-Piece Top)

Table Sizes and Seating Capacities – Without Cable Bases – Includes (6) Legs

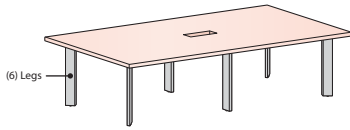

• One-Piece Top Tables specified without a Cable Base are standard with 6 Legs.

		WIDTHS								
		72" Wide	78" Wide	84" Wide	90" Wide	96" Wide	102" Wide	108" Wide	114" Wide	120" Wide
DEPTHS	36" Deep	6 Chairs Max (6 Legs)	6 Chairs Max (6 Legs)	6 Chairs Max (6 Legs)	6 Chairs Max (6 Legs)	6 Chairs Max (6 Legs)	N/A	N/A	N/A	N/A
	42" Deep	N/A	N/A	6 Chairs Max (6 Legs)	6 Chairs Max (6 Legs)	6 Chairs Max (6 Legs)	6 Chairs Max (6 Legs)	6 Chairs Max (6 Legs)	10 Chairs Max (6 Legs)	10 Chairs Max (6 Legs)
	48" Deep	N/A	N/A	6 Chairs Max (6 Legs)	6 Chairs Max (6 Legs)	6 Chairs Max (6 Legs)	6 Chairs Max (6 Legs)	6 Chairs Max (6 Legs)	10 Chairs Max (6 Legs)	10 Chairs Max (6 Legs)
	54" Deep	N/A	N/A	6 Chairs Max (6 Legs)	6 Chairs Max (6 Legs)	6 Chairs Max (6 Legs)	6 Chairs Max (6 Legs)	6 Chairs Max (6 Legs)	10 Chairs Max (6 Legs)	10 Chairs Max (6 Legs)
	60" Deep	N/A	N/A	8 Chairs Max (6 Legs)	8 Chairs Max (6 Legs)	8 Chairs Max (6 Legs)	8 Chairs Max (6 Legs)	8 Chairs Max (6 Legs)	12 Chairs Max (6 Legs)	12 Chairs Max (6 Legs)

Table Sizes and Seating Capacities – With Cable Bases – Includes (4) Legs

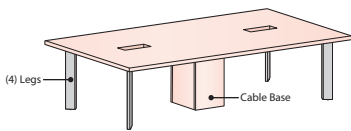

- Optional Cable Bases function as a top support allowing the number of legs to be reduced from (6) Legs down to (4) Legs.
- 36" Deep Tables specified with a Cable Base are ship with a 8" x 14" Cable Base.
- 42"-60" Deep Tables specified with a Cable Base are ship with a 14" x 14" Cable Base.

		WIDTHS								
		72" Wide	78" Wide	84" Wide	90" Wide	96" Wide	102" Wide	108" Wide	114" Wide	120" Wide
DEPTHS	36" Deep	6 Chairs Max (4 Legs/1 Cable Base)	6 Chairs Max (4 Legs/1 Cable Base)	8 Chairs Max (4 Legs/1 Cable Base)	8 Chairs Max (4 Legs/1 Cable Base)	8 Chairs Max (4 Legs/1 Cable Base)	N/A	N/A	N/A	N/A
	42" Deep	N/A	N/A	8 Chairs Max (4 Legs/1 Cable Base)	8 Chairs Max (4 Legs/1 Cable Base)	8 Chairs Max (4 Legs/1 Cable Base)	8 Chairs Max (4 Legs/1 Cable Base)	8 Chairs Max (4 Legs/1 Cable Base)	10 Chairs Max (4 Legs/1 Cable Base)	10 Chairs Max (4 Legs/1 Cable Base)
	48" Deep	N/A	N/A	8 Chairs (4 Legs/1 Cable Base)	8 Chairs (4 Legs/1 Cable Base)	8 Chairs Max (4 Legs/1 Cable Base)	8 Chairs Max (4 Legs/1 Cable Base)	8 Chairs Max (4 Legs/1 Cable Base)	10 Chairs Max (4 Legs/1 Cable Base)	10 Chairs Max (4 Legs/1 Cable Base)
	54" Deep	N/A	N/A	8 Chairs (4 Legs/1 Cable Base)	8 Chairs (4 Legs/1 Cable Base)	8 Chairs Max (4 Legs/1 Cable Base)	8 Chairs Max (4 Legs/1 Cable Base)	8 Chairs Max (4 Legs/1 Cable Base)	10 Chairs Max (4 Legs/1 Cable Base)	10 Chairs Max (4 Legs/1 Cable Base)
	60" Deep	N/A	N/A	10 Chairs (4 Legs/1 Cable Base)	10 Chairs (4 Legs/1 Cable Base)	10 Chairs Max (4 Legs/1 Cable Base)	10 Chairs Max (4 Legs/1 Cable Base)	10 Chairs Max (4 Legs/1 Cable Base)	12 Chairs Max (4 Legs/1 Cable Base)	12 Chairs Max (4 Legs/1 Cable Base)

Note Recommended seating capacity based upon a width of 27" per chair.

Product Details – Planes Interior Leg Conference Tables

Pebble (One-Piece Top)

Without Cable Base – Includes (6) Legs

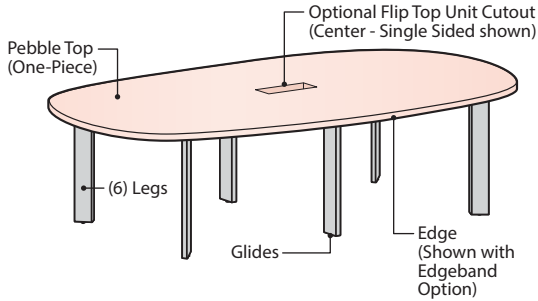

With Cable Base – Includes (4) Legs

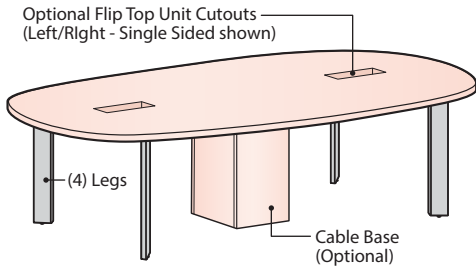

Edge Options for Laminate Tops

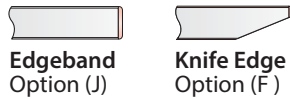

Edge Options for Wood Tops

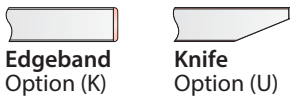

Component Materials/Finishes

COMPONENT NAME	MATERIALS/ FINISHES				
Pebble Top 1-Piece top	Laminate Top – Specify separate finish colors for top and edge trim • Edge Options: (J) Edgeband, (F) Knife				
	Wood Top – Specify a single finish color for the top and edge trim • Edge Options: (K) Edgeband, (U) Knife				
Interior Legs	Painted Metal – Specified Trim Color				
Glides	Standard in Black				
Cable Base (Optional)	<table border="1"> <tr> <td>Panels</td> <td>Laminate Panels – Specified surface and edge trim colors</td> </tr> <tr> <td>Wood Panels</td> <td>Specified top and edge trim wood finish color</td> </tr> </table>	Panels	Laminate Panels – Specified surface and edge trim colors	Wood Panels	Specified top and edge trim wood finish color
	Panels	Laminate Panels – Specified surface and edge trim colors			
Wood Panels	Specified top and edge trim wood finish color				
Frame	Painted Metal – Standard in Black				

Flip Top Unit Cutout Options

Center Cutout Option

- Includes 1 Flip Top Unit cutout (centered on top)

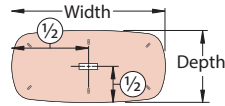

Cutout Option (F or V)

- For use with Single Sided/ 4 Port Flip Top Unit

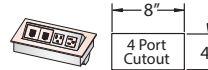

Cutout Option (M or P)

- For use with Double Sided/ 8 Ports Flip Top Unit

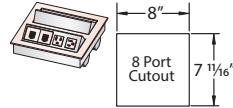

Left/Right Cutout Option

- Includes 2 Flip Top Unit cutouts (1 Left Cutout and 1 Right Cutout)

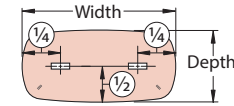

Cutout Option (J or K)

- For use with Single Sided/ 6 Ports Flip Top Unit

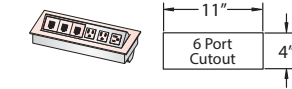

Cutout Option (Q or T)

- For use with Double Sided/ 12 Ports Flip Top Unit

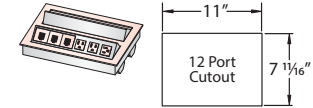

Note Flip Top Units are separately specified.

Cable Base Options

- Tables may be specified with or without Cable Bases
 - (Option N) No Cable Base.
 - (Option C) 36" deep includes 8" x 14" Cable Bases
 - 42", 48", 54" and 60" deep includes 14" x 14" Cable Bases

One-Piece Table with Cable Base Option (Top View)

36" Deep Table
Includes an
8" x 14" Cable Base
(Centered on top)

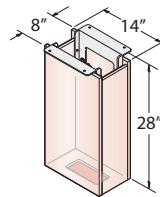
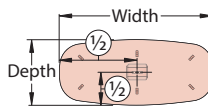

8" x 14" Cable Base

42", 48", 54", 60" Deep
Tables Includes an
8" x 14" Cable Base
(Centered on top)

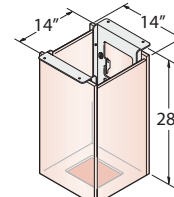
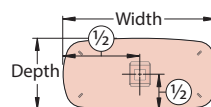

14" x 14" Cable Base

Product Details – Planes Interior Leg Conference Tables

Pebble (One-Piece Top)

Dimensions – Without Cable Base – Includes (6) Legs

Top View

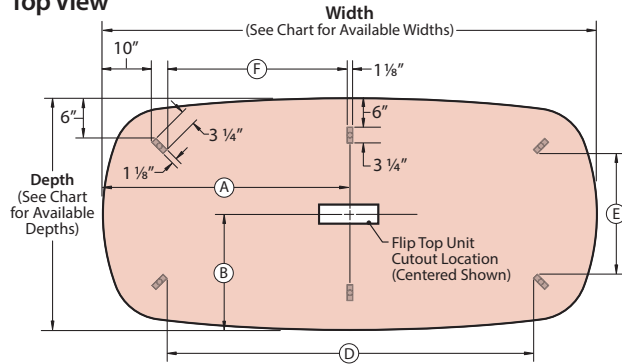

Front View

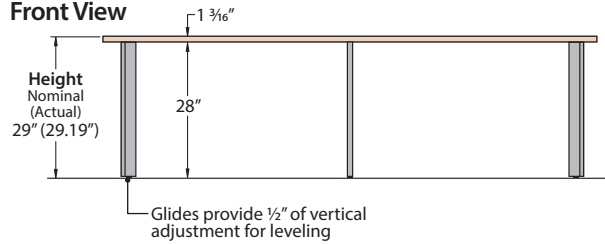

Dimensions With Cable Base – Includes (4) Legs

Top View

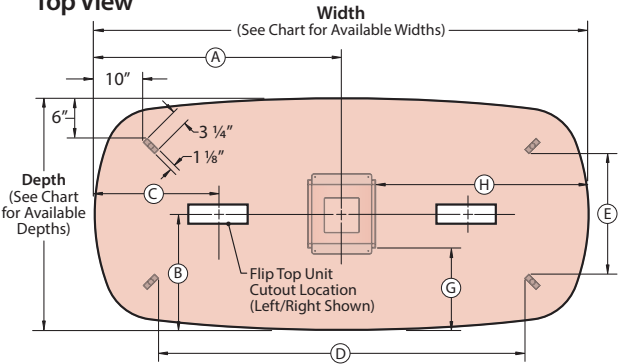

Front View

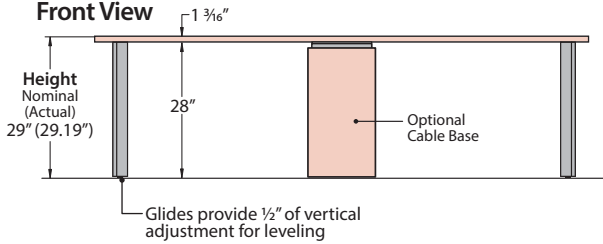

Dimensions

TABLETOP				KNEESPACE (Nominal)			LEGS		CABLE BASE				
Depth Nominal (Actual)	Width Nominal (Actual)	Number of Top Pieces	A	B	C	D	E	F	Number of Legs Without Cable Base	Number of Legs With Cable Base	Optional Cable Base Sizes	G	H
36" (35.68")	72" (71.68")	1	36"	18"	18"	46"	17"	22"	6	4	8" D x 14" W	14"	29"
	78" (77.68")	1	39"	18"	19 1/2"	52"	17"	25"	6	4	8" D x 14" W	14"	32"
	84" (83.68")	1	42"	18"	21"	58"	17"	28"	6	4	8" D x 14" W	14"	35"
	90" (89.68")	1	45"	18"	22 1/2"	64"	17"	31"	6	4	8" D x 14" W	14"	38"
	96" (95.68")	1	48"	18"	24"	70"	17"	34"	6	4	8" D x 14" W	14"	41"
42" (41.68")	84" (83.68")	1	42"	21"	21"	58"	22"	28"	6	4	14" D x 14" W	14"	35"
	90" (89.68")	1	45"	21"	22 1/2"	64"	22"	31"	6	4	14" D x 14" W	14"	38"
	96" (95.68")	1	48"	21"	24"	70"	22"	34"	6	4	14" D x 14" W	14"	41"
	102" (101.68")	1	51"	21"	25 1/2"	76"	22"	37"	6	4	14" D x 14" W	14"	47"
	108" (107.68")	1	54"	21"	27"	82"	22"	40"	6	4	14" D x 14" W	14"	50"
48" (47.68")	114" (113.68")	1	57"	21"	28 1/2"	88"	22"	43"	6	4	14" D x 14" W	14"	53"
	120" (119.68")	1	60"	21"	30"	94"	22"	46"	6	4	14" D x 14" W	14"	56"
	84" (83.68")	1	42"	24"	21"	58"	28"	28"	6	4	14" D x 14" W	17"	35"
	90" (89.68")	1	45"	24"	22 1/2"	64"	28"	31"	6	4	14" D x 14" W	17"	38"
	96" (95.68")	1	48"	24"	24"	70"	28"	34"	6	4	14" D x 14" W	17"	41"
54" (53.68")	102" (101.68")	1	51"	24"	25 1/2"	76"	28"	37"	6	4	14" D x 14" W	17"	47"
	108" (107.68")	1	54"	24"	27"	82"	28"	40"	6	4	14" D x 14" W	17"	50"
	114" (113.68")	1	57"	24"	28 1/2"	88"	28"	43"	6	4	14" D x 14" W	17"	53"
	120" (119.68")	1	60"	24"	30"	94"	28"	46"	6	4	14" D x 14" W	17"	56"
	84" (83.68")	1	42"	27"	21"	58"	34"	28"	6	4	14" D x 14" W	20"	35"
60" (59.68")	90" (89.68")	1	45"	27"	22 1/2"	64"	34"	31"	6	4	14" D x 14" W	20"	38"
	96" (95.68")	1	48"	27"	24"	70"	34"	34"	6	4	14" D x 14" W	20"	41"
	102" (101.68")	1	51"	27"	25 1/2"	76"	34"	37"	6	4	14" D x 14" W	20"	47"
	108" (107.68")	1	54"	27"	27"	82"	34"	40"	6	4	14" D x 14" W	20"	50"
	114" (113.68")	1	57"	27"	28 1/2"	88"	34"	43"	6	4	14" D x 14" W	20"	53"
120" (119.68")	1	60"	27"	30"	94"	34"	46"	6	4	14" D x 14" W	20"	56"	
60" (59.68")	84" (83.68")	1	42"	30"	21"	58"	39"	28"	6	4	14" D x 14" W	23"	35"
	90" (89.68")	1	45"	30"	22 1/2"	64"	39"	31"	6	4	14" D x 14" W	23"	38"
	96" (95.68")	1	48"	30"	24"	70"	39"	34"	6	4	14" D x 14" W	23"	41"
	102" (101.68")	1	51"	30"	25 1/2"	76"	39"	37"	6	4	14" D x 14" W	23"	47"
	108" (107.68")	1	54"	30"	27"	82"	39"	40"	6	4	14" D x 14" W	23"	50"
114" (113.68")	1	57"	30"	28 1/2"	88"	39"	43"	6	4	14" D x 14" W	23"	53"	
120" (119.68")	1	60"	30"	30"	94"	39"	46"	6	4	14" D x 14" W	23"	56"	

Product Details – Planes Interior Leg Conference Tables

Pebble (One-Piece Top)

Table Sizes and Seating Capacities – Without Cable Bases – Includes (6) Legs

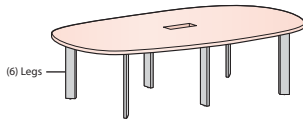

- One-Piece Top Tables specified without a Cable Base are standard with 6 Legs.

		WIDTHS								
		72" Wide	78" Wide	84" Wide	90" Wide	96" Wide	102" Wide	108" Wide	114" Wide	120" Wide
DEPTHS	36" Deep	6 Chairs Maximum	6 Chairs Maximum	6 Chairs Maximum	6 Chairs Maximum	6 Chairs Maximum	N/A	N/A	N/A	N/A
	42" Deep	N/A	N/A	6 Chairs Maximum	6 Chairs Maximum	6 Chairs Maximum	6 Chairs Maximum	6 Chairs Maximum	6 Chairs Maximum	6 Chairs Maximum
	48" Deep	N/A	N/A	6 Chairs Maximum	6 Chairs Maximum	6 Chairs Maximum	6 Chairs Maximum	6 Chairs Maximum	6 Chairs Maximum	6 Chairs Maximum
	54" Deep	N/A	N/A	8 Chairs Maximum	8 Chairs Maximum	8 Chairs Maximum	8 Chairs Maximum	6 Chairs Maximum	6 Chairs Maximum	6 Chairs Maximum
	60" Deep	N/A	N/A	6 Chairs Maximum	6 Chairs Maximum	6 Chairs Maximum	6 Chairs Maximum	6 Chairs Maximum	6 Chairs Maximum	6 Chairs Maximum

Table Sizes and Seating Capacities – With Cable Bases – Includes (4) Legs

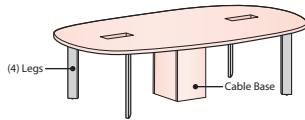

- One-Piece Top Tables specified with a Cable Base are standard with 4 Legs instead of 6 Legs because the Cable Base functions as a support for the center of the top.
- 36" Deep Tables specified with a Cable Base are ship with a 8" x 14" Cable Base.
- 42"-60" Deep Tables specified with a Cable Base are ship with a 14" x 14" Cable Base.

		WIDTHS								
		72" Wide	78" Wide	84" Wide	90" Wide	96" Wide	102" Wide	108" Wide	114" Wide	120" Wide
DEPTHS	36" Deep	6 Chairs Max (4 Legs/1 Cable Base)	6 Chairs Max (4 Legs/1 Cable Base)	6 Chairs Max (4 Legs/1 Cable Base)	6 Chairs Max (4 Legs/1 Cable Base)	8 Chairs Max (4 Legs/1 Cable Base)	N/A	N/A	N/A	N/A
	42" Deep	N/A	N/A	6 Chairs Max (4 Legs/1 Cable Base)	6 Chairs Max (4 Legs/1 Cable Base)	8 Chairs Max (4 Legs/1 Cable Base)	8 Chairs Max (4 Legs/1 Cable Base)	8 Chairs Max (4 Legs/1 Cable Base)	8 Chairs Max (4 Legs/1 Cable Base)	8 Chairs Max (4 Legs/1 Cable Base)
	48" Deep	N/A	N/A	6 Chairs (4 Legs/1 Cable Base)	6 Chairs (4 Legs/1 Cable Base)	8 Chairs Max (4 Legs/1 Cable Base)	8 Chairs Max (4 Legs/1 Cable Base)	8 Chairs Max (4 Legs/1 Cable Base)	8 Chairs Max (4 Legs/1 Cable Base)	8 Chairs Max (4 Legs/1 Cable Base)
	54" Deep	N/A	N/A	6 Chairs (4 Legs/1 Cable Base)	6 Chairs (4 Legs/1 Cable Base)	8 Chairs Max (4 Legs/1 Cable Base)	8 Chairs Max (4 Legs/1 Cable Base)	8 Chairs Max (4 Legs/1 Cable Base)	8 Chairs Max (4 Legs/1 Cable Base)	8 Chairs Max (4 Legs/1 Cable Base)
	60" Deep	N/A	N/A	6 Chairs (4 Legs/1 Cable Base)	6 Chairs (4 Legs/1 Cable Base)	8 Chairs Max (4 Legs/1 Cable Base)	8 Chairs Max (4 Legs/1 Cable Base)	8 Chairs Max (4 Legs/1 Cable Base)	8 Chairs Max (4 Legs/1 Cable Base)	8 Chairs Max (4 Legs/1 Cable Base)

Note Recommended seating capacity based upon a width of 27" per chair.

Product Details – Planes Interior Leg Conference Tables

Hexagon (One-Piece Top)

Without Cable Base – Includes (6) Legs

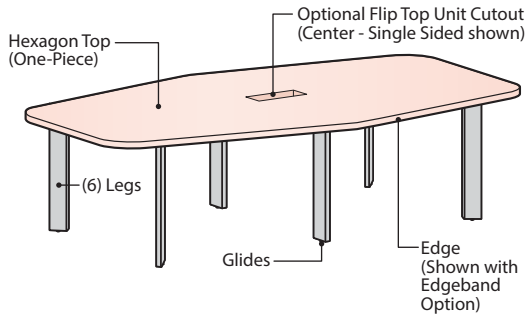

With Cable Base – Includes (4) Legs

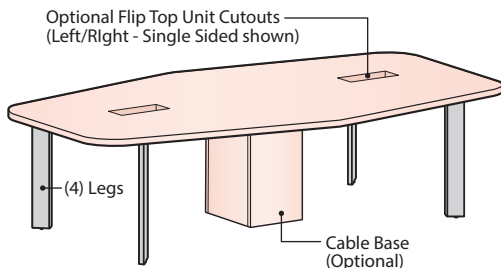

Edge Options for Laminate Tops



Edgeband
Option (J)



Knife Edge
Option (F)

Edge Options for Wood Tops

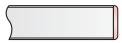

Edgeband
Option (K)



Knife
Option (U)

Component Materials/Finishes

COMPONENT NAME	MATERIALS/ FINISHES
Hexagon Top 1-Piece top	Laminate Top – Specify separate finish colors for top and edge trim • Edge Options: (J) Edgeband, (F) Knife
	Wood Top – Specify a single finish color for the top and edge trim • Edge Options: (K) Edgeband, (M) Cascade, (U) Knife
Interior Legs	Painted Metal – Specified Trim Color
Glides	Standard in Black
Cable Base (Optional)	Panels
	Frame
	Laminate Panels – Specified surface and edge trim colors
	Wood Panels – Specified top and edge trim wood finish color
	Painted Metal – Standard in Black

Flip Top Unit Cutout Options

Center Cutout Option

- Includes 3 Flip Top Unit cutouts
(1 Cutout centered on each top piece)

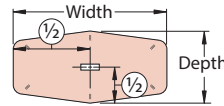

Cutout Option (F or V)

- For use with Single Sided/
4 Port Flip Top Unit

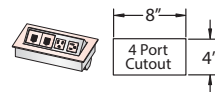

Cutout Option (M or P)

- For use with Double Sided/
8 Ports Flip Top Unit

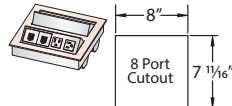

Left/Right Cutout Option

- Includes 6 Flip Top Unit cutouts
(2 Cutouts on each top piece)

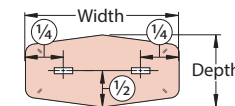

Cutout Option (J or K)

- For use with Single Sided/
6 Ports Flip Top Unit

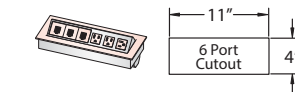

Cutout Option (Q or T)

- For use with Double Sided/
12 Ports Flip Top Unit

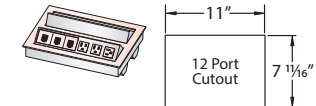

Note Flip Top Units are separately specified.

Cable Base Options

- Tables may be specified with or without Cable Bases
 - (Option N) No Cable Base.
 - (Option C) 36" deep includes 8" x 14" Cable Bases
42", 48", 54" and 60" table includes 14" x 14" Cable Bases

One-Piece Table with Cable Base option (Top View)

36" Deep Table
Includes an
8" x 14" Cable Base
(Centered on top)

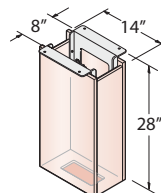
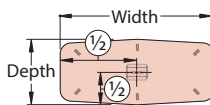

8" x 14"
Cable Base

42", 48", 54", 60" Deep
Tables Includes an
8" x 14" Cable Base
(Centered on top)

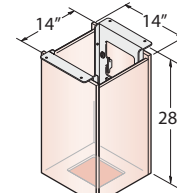
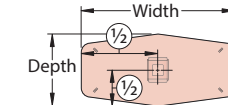

14" x 14"
Cable Base

Product Details – Planes Interior Leg Conference Tables

Hexagon (One-Piece Top)

Dimensions – Without Cable Base – Includes (6) Legs

Top View

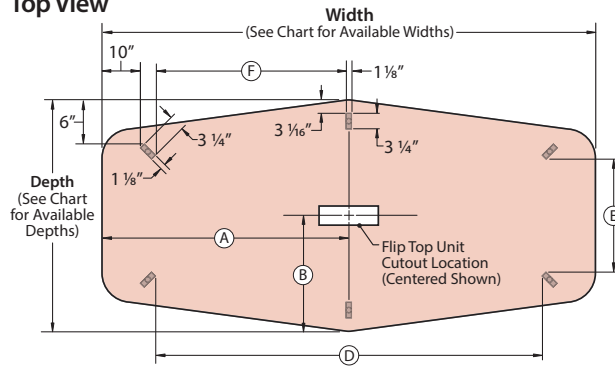

Front View

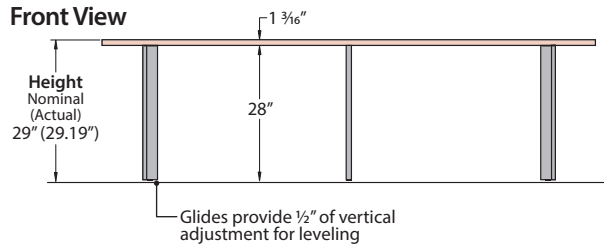

Dimensions – With Cable Base – Includes (4) Legs

Top View

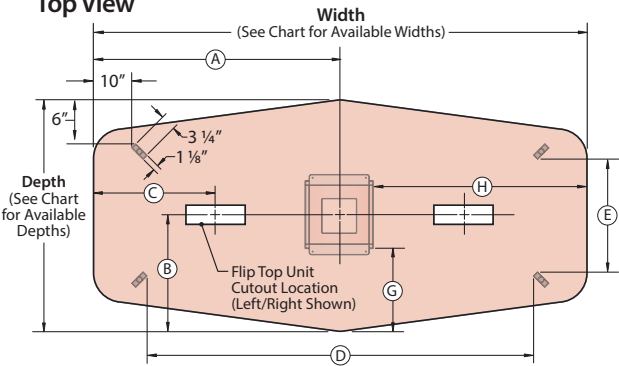

Front View

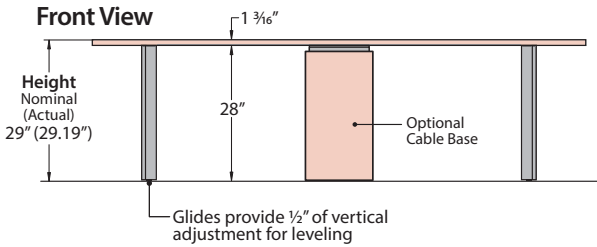

Dimensions

TABLETOP				KNEESPACE (Nominal)			LEGS		CABLE BASE				
Depth Nominal (Actual)	Width Nominal (Actual)	Number of Top Pieces	A	B	C	D	E	F	Number of Legs Without Cable Base	Number of Legs With Cable Base	Optional Cable Base Sizes	G	H
36" (35.68")	72" (71.68")	1	36"	18"	18"	50"	18"	24"	6	4	8" D x 14" W	14"	29"
	78" (77.68")	1	39"	18"	19 1/2"	56"	18"	27"	6	4	8" D x 14" W	14"	32"
	84" (83.68")	1	42"	18"	21"	62"	18"	30"	6	4	8" D x 14" W	14"	35"
	90" (89.68")	1	45"	18"	22 1/2"	68"	18"	33"	6	4	8" D x 14" W	14"	38"
	96" (95.68")	1	48"	18"	24"	74"	18"	36"	6	4	8" D x 14" W	14"	41"
42" (41.68")	84" (83.68")	1	42"	21"	21"	62"	24"	30"	6	4	14" D x 14" W	14"	35"
	90" (89.68")	1	45"	21"	22 1/2"	68"	24"	33"	6	4	14" D x 14" W	14"	38"
	96" (95.68")	1	48"	21"	24"	74"	24"	36"	6	4	14" D x 14" W	14"	41"
	102" (101.68")	1	51"	21"	25 1/2"	80"	24"	39"	6	4	14" D x 14" W	14"	47"
	108" (107.68")	1	54"	21"	27"	86"	24"	42"	6	4	14" D x 14" W	14"	50"
	114" (113.68")	1	57"	21"	28 1/2"	92"	24"	45"	6	4	14" D x 14" W	14"	53"
48" (47.68")	120" (119.68")	1	60"	21"	30"	98"	24"	48"	6	4	14" D x 14" W	14"	56"
	84" (83.68")	1	42"	24"	21"	62"	23"	30"	6	4	14" D x 14" W	17"	35"
	90" (89.68")	1	45"	24"	22 1/2"	68"	23"	33"	6	4	14" D x 14" W	17"	38"
	96" (95.68")	1	48"	24"	24"	74"	23"	36"	6	4	14" D x 14" W	17"	41"
	102" (101.68")	1	51"	24"	25 1/2"	80"	23"	39"	6	4	14" D x 14" W	17"	47"
	108" (107.68")	1	54"	24"	27"	86"	23"	42"	6	4	14" D x 14" W	17"	50"
	114" (113.68")	1	57"	24"	28 1/2"	92"	23"	45"	6	4	14" D x 14" W	17"	53"
54" (53.68")	120" (119.68")	1	60"	24"	30"	98"	23"	48"	6	4	14" D x 14" W	17"	56"
	84" (83.68")	1	42"	27"	21"	62"	29"	30"	6	4	14" D x 14" W	20"	35"
	90" (89.68")	1	45"	27"	22 1/2"	68"	29"	33"	6	4	14" D x 14" W	20"	38"
	96" (95.68")	1	48"	27"	24"	74"	29"	36"	6	4	14" D x 14" W	20"	41"
	102" (101.68")	1	51"	27"	25 1/2"	80"	29"	39"	6	4	14" D x 14" W	20"	47"
	108" (107.68")	1	54"	27"	27"	86"	29"	42"	6	4	14" D x 14" W	20"	50"
60" (59.68")	114" (113.68")	1	57"	27"	28 1/2"	92"	29"	45"	6	4	14" D x 14" W	20"	53"
	120" (119.68")	1	60"	27"	30"	98"	29"	48"	6	4	14" D x 14" W	20"	56"
	84" (83.68")	1	42"	30"	21"	62"	35"	30"	6	4	14" D x 14" W	23"	35"
	90" (89.68")	1	45"	30"	22 1/2"	68"	35"	33"	6	4	14" D x 14" W	23"	38"
	96" (95.68")	1	48"	30"	24"	74"	35"	36"	6	4	14" D x 14" W	23"	41"
	102" (101.68")	1	51"	30"	25 1/2"	80"	35"	39"	6	4	14" D x 14" W	23"	47"
	108" (107.68")	1	54"	30"	27"	86"	35"	42"	6	4	14" D x 14" W	23"	50"
114" (113.68")	1	57"	30"	28 1/2"	92"	35"	45"	6	4	14" D x 14" W	23"	53"	
120" (119.68")	1	60"	30"	30"	98"	35"	48"	6	4	14" D x 14" W	23"	56"	

Product Details – Planes Interior Leg Conference Tables

Hexagon (One-Piece Top)

Table Sizes and Seating Capacities – Without Cable Bases – Includes (6) Legs

• One-Piece Top Tables specified without a Cable Base are standard with 6 Legs.

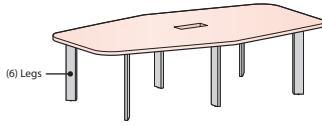

		WIDTHS								
		72" Wide	78" Wide	84" Wide	90" Wide	96" Wide	102" Wide	108" Wide	114" Wide	120" Wide
DEPTHS	36" Deep	6 Chairs Maximum	6 Chairs Maximum	6 Chairs Maximum	6 Chairs Maximum	6 Chairs Maximum	N/A	N/A	N/A	N/A
	42" Deep	N/A	N/A	6 Chairs Maximum	6 Chairs Maximum	6 Chairs Maximum	6 Chairs Maximum	6 Chairs Maximum	6 Chairs Maximum	10 Chairs Maximum
	48" Deep	N/A	N/A	6 Chairs Maximum	6 Chairs Maximum	6 Chairs Maximum	6 Chairs Maximum	6 Chairs Maximum	6 Chairs Maximum	10 Chairs Maximum
	54" Deep	N/A	N/A	6 Chairs Maximum	6 Chairs Maximum	6 Chairs Maximum	6 Chairs Maximum	6 Chairs Maximum	6 Chairs Maximum	10 Chairs Maximum
	60" Deep	N/A	N/A	6 Chairs Maximum	6 Chairs Maximum	6 Chairs Maximum	6 Chairs Maximum	6 Chairs Maximum	6 Chairs Maximum	10 Chairs Maximum

Table Sizes and Seating Capacities – With Cable Bases – Includes (4) Legs

• One-Piece Top Tables specified with a Cable Base are standard with 4 Legs instead of 6 Legs because the Cable Base functions as a support for the center of the top.
 • 36" Deep Tables specified with a Cable Base are ship with a 8" x 14" Cable Base.
 • 42"-60" Deep Tables specified with a Cable Base are ship with a 14" x 14" Cable Base.

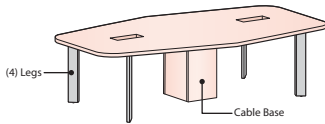

		WIDTHS								
		72" Wide	78" Wide	84" Wide	90" Wide	96" Wide	102" Wide	108" Wide	114" Wide	120" Wide
DEPTHS	36" Deep	6 Chairs Max. (4 Legs/ 1 Cable Base)	6 Chairs Max. (4 Legs/ 1 Cable Base)	6 Chairs Max. (4 Legs/ 1 Cable Base)	6 Chairs Max. (4 Legs/ 1 Cable Base)	8 Chairs Max. (4 Legs/ 1 Cable Base)	N/A	N/A	N/A	N/A
	42" Deep	N/A	N/A	6 Chairs Max. (4 Legs/ 1 Cable Base)	6 Chairs Max. (4 Legs/ 1 Cable Base)	8 Chairs Max. (4 Legs/ 1 Cable Base)	8 Chairs Max. (4 Legs/ 1 Cable Base)	10 Chairs Max. (4 Legs/ 1 Cable Base)	8 Chairs Max. (4 Legs/ 1 Cable Base)	8 Chairs Max. (4 Legs/ 1 Cable Base)
	48" Deep	N/A	N/A	6 Chairs Max. (4 Legs/ 1 Cable Base)	6 Chairs Max. (4 Legs/ 1 Cable Base)	8 Chairs Max. (4 Legs/ 1 Cable Base)	8 Chairs Max. (4 Legs/ 1 Cable Base)	10 Chairs Max. (4 Legs/ 1 Cable Base)	8 Chairs Max. (4 Legs/ 1 Cable Base)	8 Chairs Max. (4 Legs/ 1 Cable Base)
	54" Deep	N/A	N/A	6 Chairs Max. (4 Legs/ 1 Cable Base)	6 Chairs Max. (4 Legs/ 1 Cable Base)	8 Chairs Max. (4 Legs/ 1 Cable Base)	8 Chairs Max. (4 Legs/ 1 Cable Base)	8 Chairs Max. (4 Legs/ 1 Cable Base)	8 Chairs Max. (4 Legs/ 1 Cable Base)	8 Chairs Max. (4 Legs/ 1 Cable Base)
	60" Deep	N/A	N/A	6 Chairs Max. (4 Legs/ 1 Cable Base)	6 Chairs Max. (4 Legs/ 1 Cable Base)	8 Chairs Max. (4 Legs/ 1 Cable Base)	8 Chairs Max. (4 Legs/ 1 Cable Base)	8 Chairs Max. (4 Legs/ 1 Cable Base)	8 Chairs Max. (4 Legs/ 1 Cable Base)	8 Chairs Max. (4 Legs/ 1 Cable Base)

Note Recommended seating capacity based upon a width of 27" per chair.

Product Details – Planes Interior Leg Conference Tables

Rectangular (Two-Piece Top)

Without Cable Base

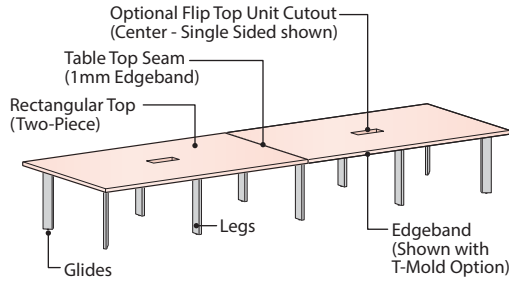

With Cable Base

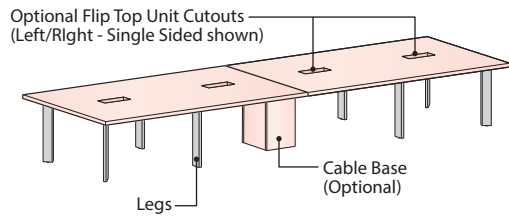

Edge Options for Laminate Tops

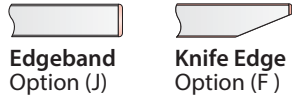

Edge Options for Wood Tops

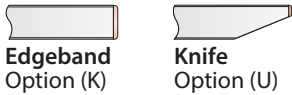

Component Materials/Finishes

COMPONENT NAME	MATERIALS/ FINISHES
Rectangle Top 2-Piece top with 1mm edgeband seam	Laminate Top – Specify separate finish colors for top and edge trim • Edge Options: (J) Edgeband, (F) Knife
	Wood Top – Specify a single finish color for the top and edge trim • Edge Options: (K) Edgeband, (U) Knife
Interior Legs	Painted Metal – Specified Trim Color
Glides	Standard in Black
Cable Base (Optional)	Panels Laminate Panels – Specified surface and edge trim colors Wood Panels – Specified top and edge trim wood finish color
	Frame Painted Metal – Standard in Black

Flip Top Unit Cutout Options

Center Cutout Option

- Includes 3 Flip Top Unit cutouts (1 Cutout centered on each top piece)

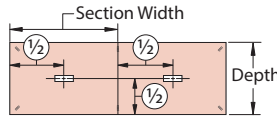

Left/Right Cutout Option

- Includes 6 Flip Top Unit cutouts (2 Cutouts on each top piece)

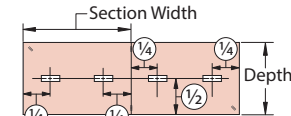

Cutout Option (F or V)

- For use with Single Sided/ 4 Port Flip Top Unit

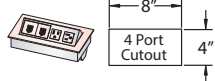

Cutout Option (J or K)

- For use with Single Sided/ 6 Ports Flip Top Unit

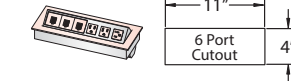

Cutout Option (M or P)

- For use with Double Sided/ 8 Ports Flip Top Unit

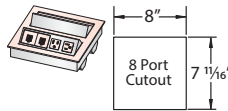

Cutout Option (Q or T)

- For use with Double Sided/ 12 Ports Flip Top Unit

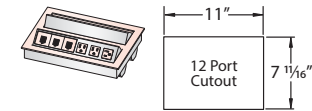

Note Flip Top Units are separately specified.

Cable Base Options

- Tables may be specified with or without Cable Bases
 - (Option N) No Cable Base.
 - (Option C) Includes 14" x 14" Cable Bases

Two-Piece Table with Cable Base option (Top View)

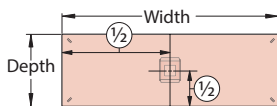

Cable Base is centered on the seam between top pieces.

14" x 14" Cable Base (42", 48", 54", 60" Deep Tables)

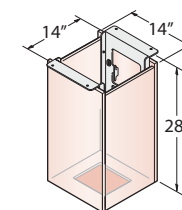

Product Details – Planes Interior Leg Conference Tables

Rectangular (Two-Piece Top)

Dimensions – 126"-132" Wide
Tables Without Cable Base
Includes (6) Legs

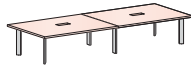

Top View

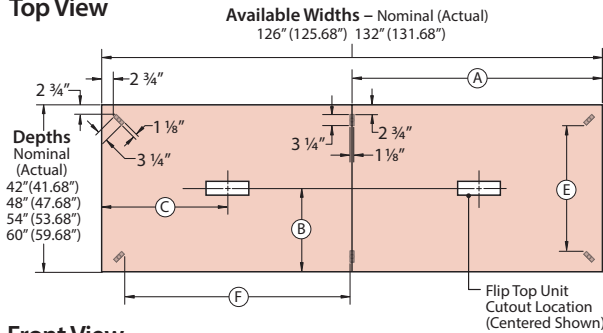

Front View

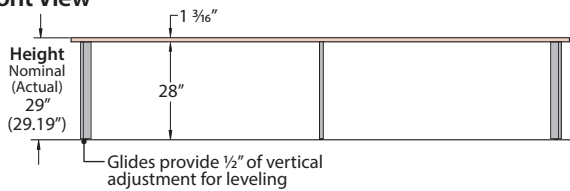

Dimensions – 138"-180" Wide
Tables Without Cable Base
Includes (10) Legs

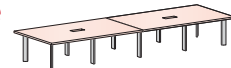

Top View

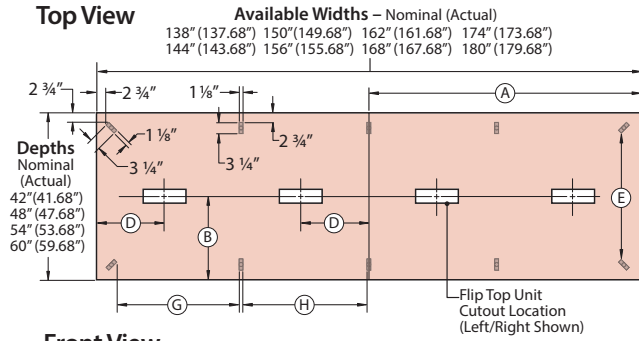

Front View

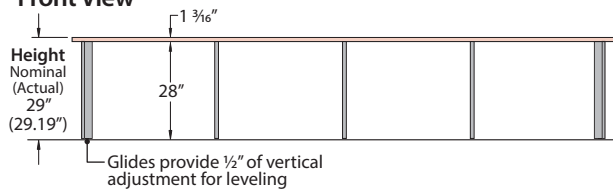

Dimensions

Depth Nominal (Actual)	TABLETOP		KNEESPACE (Nominal)								LEGS Number of Legs Without Cable Base
	Width Nominal (Actual)	Number of Top Pieces	A	B	C	D	E	F	G	H	
42" (41.68")	126" (125.68")	2	63"	21"	31 1/2"	15 3/4"	27"	55"	N/A	N/A	6
	132" (131.68")	2	66"	21"	33"	16 1/2"	27"	58"	N/A	N/A	6
	138" (137.68")	2	69"	21"	34 1/2"	17 1/4"	27"	N/A	26"	33"	10
	144" (143.68")	2	72"	21"	36"	18"	27"	N/A	28"	34"	10
	150" (149.68")	2	75"	21"	37 1/2"	18 3/4"	27"	N/A	29"	36"	10
	156" (155.68")	2	78"	21"	39"	19 1/2"	27"	N/A	31"	37"	10
	162" (161.68")	2	81"	21"	40 1/2"	20 1/4"	27"	N/A	32"	39"	10
	168" (167.68")	2	84"	21"	42"	21"	27"	N/A	34"	40"	10
	174" (173.68")	2	87"	21"	43 1/2"	21 3/4"	27"	N/A	35"	42"	10
48" (47.68")	126" (125.68")	2	63"	24"	31 1/2"	15 3/4"	33"	55"	N/A	N/A	6
	132" (131.68")	2	66"	24"	33"	16 1/2"	33"	58"	N/A	N/A	6
	138" (137.68")	2	69"	24"	34 1/2"	17 1/4"	33"	N/A	26"	33"	10
	144" (143.68")	2	72"	24"	36"	18"	33"	N/A	28"	34"	10
	150" (149.68")	2	75"	24"	37 1/2"	18 3/4"	33"	N/A	29"	36"	10
	156" (155.68")	2	78"	24"	39"	19 1/2"	33"	N/A	31"	37"	10
	162" (161.68")	2	81"	24"	40 1/2"	20 1/4"	33"	N/A	32"	39"	10
	168" (167.68")	2	84"	24"	42"	21"	33"	N/A	34"	40"	10
	174" (173.68")	2	87"	24"	43 1/2"	21 3/4"	33"	N/A	35"	42"	10
54" (53.68")	126" (125.68")	2	63"	27"	31 1/2"	15 3/4"	39"	55"	N/A	N/A	6
	132" (131.68")	2	66"	27"	33"	16 1/2"	39"	58"	N/A	N/A	6
	138" (137.68")	2	69"	27"	34 1/2"	17 1/4"	39"	N/A	26"	33"	10
	144" (143.68")	2	72"	27"	36"	18"	39"	N/A	28"	34"	10
	150" (149.68")	2	75"	27"	37 1/2"	18 3/4"	39"	N/A	29"	36"	10
	156" (155.68")	2	78"	27"	39"	19 1/2"	39"	N/A	31"	37"	10
	162" (161.68")	2	81"	27"	40 1/2"	20 1/4"	39"	N/A	32"	39"	10
	168" (167.68")	2	84"	27"	42"	21"	39"	N/A	34"	40"	10
	174" (173.68")	2	87"	27"	43 1/2"	21 3/4"	39"	N/A	35"	42"	10
60" (59.68")	126" (125.68")	2	63"	30"	31 1/2"	15 3/4"	45"	55"	N/A	N/A	6
	132" (131.68")	2	66"	30"	33"	16 1/2"	45"	58"	N/A	N/A	6
	138" (137.68")	2	69"	30"	34 1/2"	17 1/4"	45"	N/A	26"	33"	10
	144" (143.68")	2	72"	30"	36"	18"	45"	N/A	28"	34"	10
	150" (149.68")	2	75"	30"	37 1/2"	18 3/4"	45"	N/A	29"	36"	10
	156" (155.68")	2	78"	30"	39"	19 1/2"	45"	N/A	31"	37"	10
	162" (161.68")	2	81"	30"	40 1/2"	20 1/4"	45"	N/A	32"	39"	10
	168" (167.68")	2	84"	30"	42"	21"	45"	N/A	34"	40"	10
	174" (173.68")	2	87"	30"	43 1/2"	21 3/4"	45"	N/A	35"	42"	10
180" (179.68")	2	90"	30"	45"	22 1/2"	45"	N/A	37"	43"	10	

Product Details – Planes Interior Leg Conference Tables

Rectangular (Two-Piece Top)

**Dimensions – 126"-132" Wide
Tables With Cable Base
Includes (4) Legs**

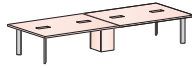

Top View

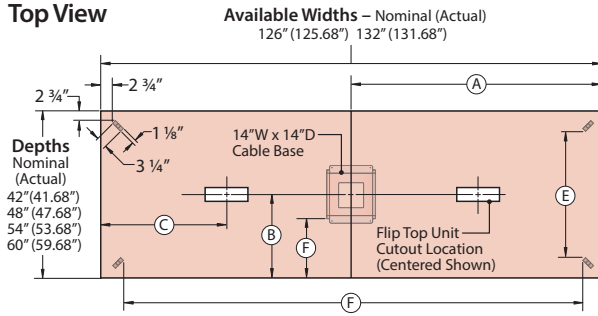

Front View

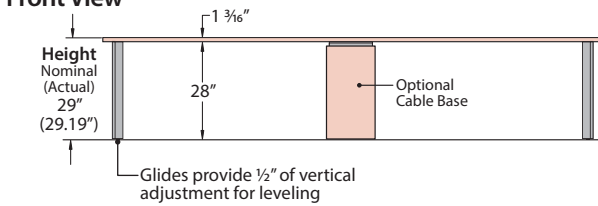

**Dimensions – 138"-180" Wide
Tables With Cable Base
Includes (8) Legs**

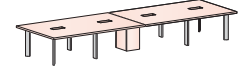

Top View

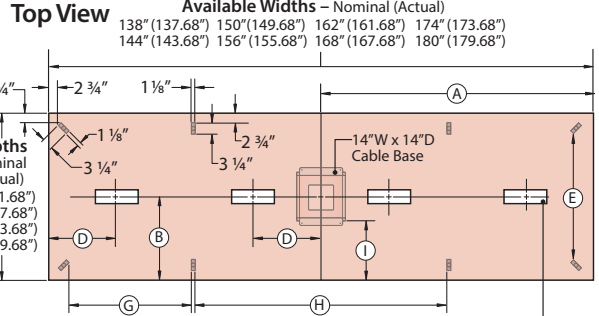

Front View

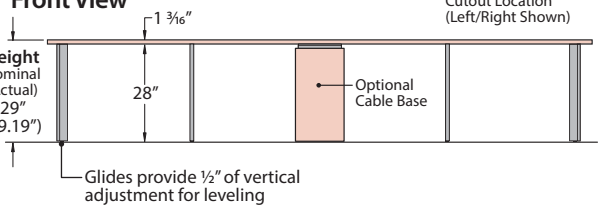

Dimensions

Depth Nominal (Actual)	TABLETOP						KNEESPACE (Nominal)					LEGS	CABLE BASE
	Width Nominal (Actual)	Number of Top Pieces	A	B	C	D	E	F	G	H	I	Number of Legs With Cable Base	Optional Cable Base Sizes
42" (41.68")	126" (125.68")	2	63"	21"	31 1/2"	15 3/4"	27"	112"	N/A	N/A	14"	4	14" D x 14" W
	132" (131.68")	2	66"	21"	33"	16 1/2"	27"	118"	N/A	N/A	14"	4	14" D x 14" W
	138" (137.68")	2	69"	21"	34 1/2"	17 1/4"	27"	N/A	26"	68"	14"	8	14" D x 14" W
	144" (143.68")	2	72"	21"	36"	18"	27"	N/A	28"	70"	14"	8	14" D x 14" W
	150" (149.68")	2	75"	21"	37 1/2"	18 3/4"	27"	N/A	29"	74"	14"	8	14" D x 14" W
	156" (155.68")	2	78"	21"	39"	19 1/2"	27"	N/A	31"	76"	14"	8	14" D x 14" W
	162" (161.68")	2	81"	21"	40 1/2"	20 1/4"	27"	N/A	32"	80"	14"	8	14" D x 14" W
	168" (167.68")	2	84"	21"	42"	21"	27"	N/A	34"	82"	14"	8	14" D x 14" W
	174" (173.68")	2	87"	21"	43 1/2"	21 3/4"	27"	N/A	35"	86"	14"	8	14" D x 14" W
180" (179.68")	2	90"	21"	45"	22 1/2"	27"	N/A	37"	88"	14"	8	14" D x 14" W	
48" (47.68")	126" (125.68")	2	63"	24"	31 1/2"	15 3/4"	33"	112"	N/A	N/A	17"	4	14" D x 14" W
	132" (131.68")	2	66"	24"	33"	16 1/2"	33"	118"	N/A	N/A	17"	4	14" D x 14" W
	138" (137.68")	2	69"	24"	34 1/2"	17 1/4"	33"	N/A	26"	68"	17"	8	14" D x 14" W
	144" (143.68")	2	72"	24"	36"	18"	33"	N/A	28"	70"	17"	8	14" D x 14" W
	150" (149.68")	2	75"	24"	37 1/2"	18 3/4"	33"	N/A	29"	74"	17"	8	14" D x 14" W
	156" (155.68")	2	78"	24"	39"	19 1/2"	33"	N/A	31"	76"	17"	8	14" D x 14" W
	162" (161.68")	2	81"	24"	40 1/2"	20 1/4"	33"	N/A	32"	80"	17"	8	14" D x 14" W
	168" (167.68")	2	84"	24"	42"	21"	33"	N/A	34"	82"	17"	8	14" D x 14" W
	174" (173.68")	2	87"	24"	43 1/2"	21 3/4"	33"	N/A	35"	86"	17"	8	14" D x 14" W
180" (179.68")	2	90"	24"	45"	22 1/2"	33"	N/A	37"	88"	17"	8	14" D x 14" W	
54" (53.68")	126" (125.68")	2	63"	27"	31 1/2"	15 3/4"	39"	112"	N/A	N/A	20"	4	14" D x 14" W
	132" (131.68")	2	66"	27"	33"	16 1/2"	39"	118"	N/A	N/A	20"	4	14" D x 14" W
	138" (137.68")	2	69"	27"	34 1/2"	17 1/4"	39"	N/A	26"	68"	20"	8	14" D x 14" W
	144" (143.68")	2	72"	27"	36"	18"	39"	N/A	28"	70"	20"	8	14" D x 14" W
	150" (149.68")	2	75"	27"	37 1/2"	18 3/4"	39"	N/A	29"	74"	20"	8	14" D x 14" W
	156" (155.68")	2	78"	27"	39"	19 1/2"	39"	N/A	31"	76"	20"	8	14" D x 14" W
	162" (161.68")	2	81"	27"	40 1/2"	20 1/4"	39"	N/A	32"	80"	20"	8	14" D x 14" W
	168" (167.68")	2	84"	27"	42"	21"	39"	N/A	34"	82"	20"	8	14" D x 14" W
	174" (173.68")	2	87"	27"	43 1/2"	21 3/4"	39"	N/A	35"	86"	20"	8	14" D x 14" W
180" (179.68")	2	90"	27"	45"	22 1/2"	39"	N/A	37"	88"	20"	8	14" D x 14" W	
60" (59.68")	126" (125.68")	2	63"	30"	31 1/2"	15 3/4"	45"	112"	N/A	N/A	23"	4	14" D x 14" W
	132" (131.68")	2	66"	30"	33"	16 1/2"	45"	118"	N/A	N/A	23"	4	14" D x 14" W
	138" (137.68")	2	69"	30"	34 1/2"	17 1/4"	45"	N/A	26"	68"	23"	8	14" D x 14" W
	144" (143.68")	2	72"	30"	36"	18"	45"	N/A	28"	70"	23"	8	14" D x 14" W
	150" (149.68")	2	75"	30"	37 1/2"	18 3/4"	45"	N/A	29"	74"	23"	8	14" D x 14" W
	156" (155.68")	2	78"	30"	39"	19 1/2"	45"	N/A	31"	76"	23"	8	14" D x 14" W
	162" (161.68")	2	81"	30"	40 1/2"	20 1/4"	45"	N/A	32"	80"	23"	8	14" D x 14" W
	168" (167.68")	2	84"	30"	42"	21"	45"	N/A	34"	82"	23"	8	14" D x 14" W
	174" (173.68")	2	87"	30"	43 1/2"	21 3/4"	45"	N/A	35"	86"	23"	8	14" D x 14" W
180" (179.68")	2	90"	30"	45"	22 1/2"	45"	N/A	37"	88"	23"	8	14" D x 14" W	

Product Details – Planes Interior Leg Conference Tables

Rectangular (Two-Piece Top)

Table Sizes and Seating Capacities – Without Cable Bases – Includes (10) Legs

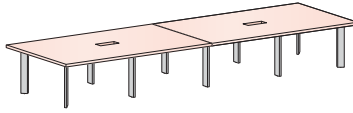

- 126" and 132" Wide Two-Piece Top Tables specified without a Cable Base are standard with 6 Legs.
- 138", 144", 150", 156", 162", 168", 174", 180" Wide Two-Piece Top Tables specified without a Cable Base are standard with 10 Legs.

		WIDTHS									
		126" Wide	132" Wide	138" Wide	144" Wide	150" Wide	156" Wide	162" Wide	168" Wide	174" Wide	180" Wide
DEPTHS	42" Deep										
	48" Deep										
	54" Deep										
	60" Deep										

Table Sizes and Seating Capacities – With Cable Bases – Includes (4) Legs

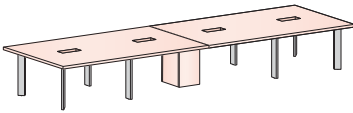

- 126" and 132" Wide Two-Piece Top Tables specified with a Cable Base are standard with 4 Legs.
- 138", 144", 150", 156", 162", 168", 174", 180" Wide Two-Piece Top Tables specified with a Cable Base are standard with 8 Legs.

		WIDTHS									
		126" Wide	132" Wide	138" Wide	144" Wide	150" Wide	156" Wide	162" Wide	168" Wide	174" Wide	180" Wide
DEPTHS	42" Deep										
	48" Deep										
	54" Deep										
	60" Deep										

Note Recommended seating capacity based upon a width of 27" per chair.

Product Details – Planes Interior Leg Conference Tables

Pebble (Two-Piece Top)

Without Cable Base

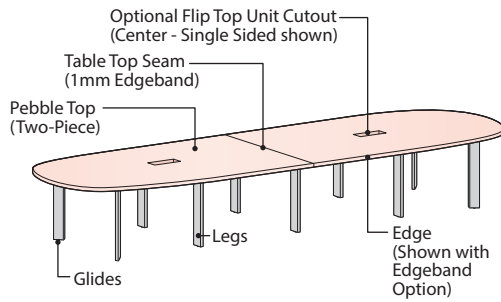

With Cable Base

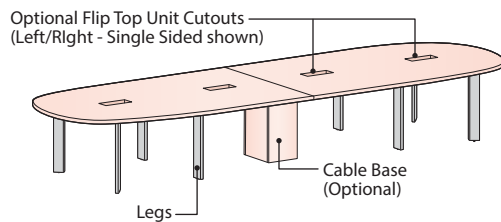

Edge Options for Laminate Tops

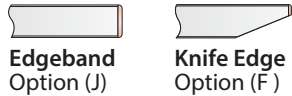

Edge Options for Wood Tops



Component Materials/Finishes

COMPONENT NAME	MATERIALS/ FINISHES
Pebble Top 2-Piece top with 1mm edgeband seam	Laminate Top – Specify separate finish colors for top and edge trim • Edge Options: (J) Edgeband, (F) Knife
	Wood Top – Specify a single finish color for the top and edge trim • Edge Options: (K) Edgeband, (U) Knife
Interior Legs	Painted Metal – Specified Trim Color
Glides	Standard in Black
Cable Base (Optional)	Panels Laminate Panels – Specified surface and edge trim colors Wood Panels – Specified top and edge trim wood finish color
	Frame Painted Metal – Standard in Black

Flip Top Unit Cutout Options

Center Cutout Option

- Includes 3 Flip Top Unit cutouts (1 Cutout centered on each top piece)

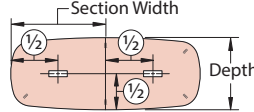

Left/Right Cutout Option

- Includes 6 Flip Top Unit cutouts (2 Cutouts on each top piece)

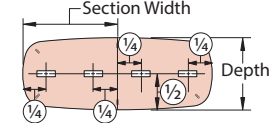

Cutout Option (F or V)

- For use with Single Sided/ 4 Port Flip Top Unit

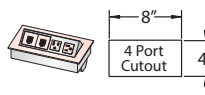

Cutout Option (J or K)

- For use with Single Sided/ 6 Ports Flip Top Unit

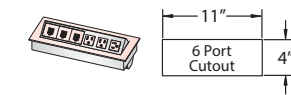

Cutout Option (M or P)

- For use with Double Sided/ 8 Ports Flip Top Unit

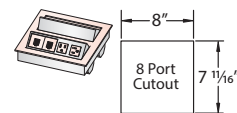

Cutout Option (Q or T)

- For use with Double Sided/ 12 Ports Flip Top Unit

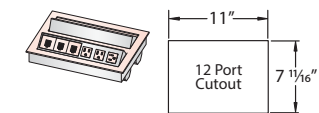

Note Flip Top Units are separately specified.

Cable Base Options

- Tables may be specified with or without Cable Bases
 - (Option N) No Cable Base.
 - (Option C) Includes 14" x 14" Cable Bases

Two-Piece Table with Cable Base option (Top View)

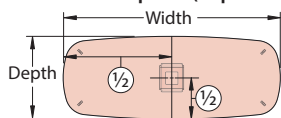

Cable Base is centered on the seam between top pieces.

14" x 14" Cable Base (42", 48", 54", 60" Deep Tables)

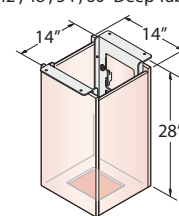

Product Details – Planes Interior Leg Conference Tables

Pebble (Two-Piece Top)

**Dimensions – 126"-144" Wide
Tables Without Cable Base
Includes (6) Legs**

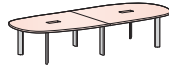

Top View

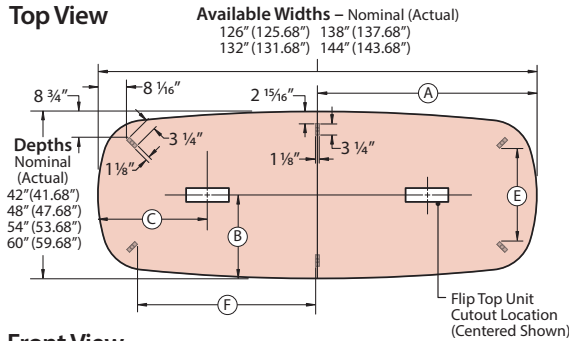

Front View

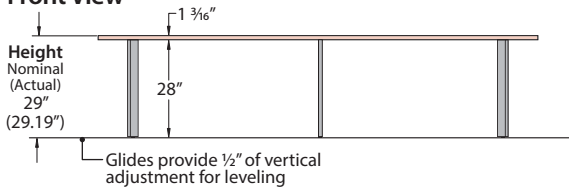

**Dimensions – 150"-180" Wide
Tables Without Cable Base
Includes (10) Legs**

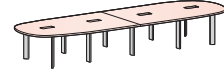

Top View

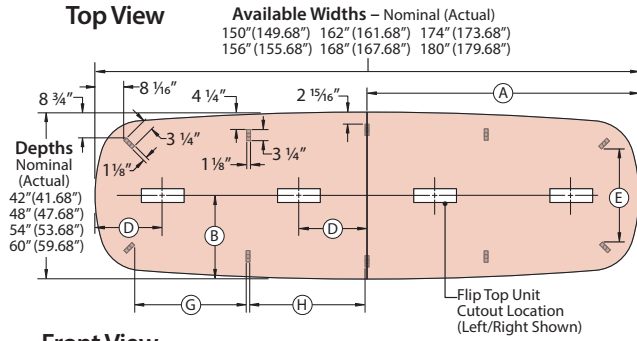

Front View

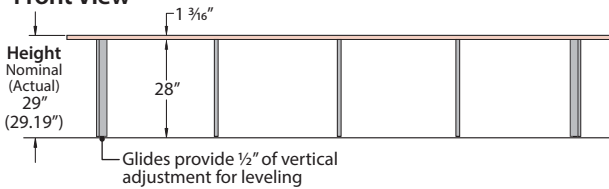

Dimensions

Depth Nominal (Actual)	TABLETOP						KNEESPACE (Nominal)				Number of Legs Without Cable Base
	Width Nominal (Actual)	Number of Top Pieces	A	B	C	D	E	F	G	H	
42" (41.68")	126" (125.68")	2	63"	21"	31 1/2"	15 3/4"	22"	51"	N/A	N/A	6
	132" (131.68")	2	66"	21"	33"	16 1/2"	22"	54"	N/A	N/A	6
	138" (137.68")	2	69"	21"	34 1/2"	17 1/4"	22"	57"	N/A	N/A	6
	144" (143.68")	2	72"	21"	36"	18"	22"	60"	N/A	N/A	6
	150" (149.68")	2	75"	21"	37 1/2"	18 3/4"	22"	N/A	30"	32"	10
	156" (155.68")	2	78"	21"	39"	19 1/2"	22"	N/A	32"	33"	10
	162" (161.68")	2	81"	21"	40 1/2"	20 1/4"	22"	N/A	33"	35"	10
	168" (167.68")	2	84"	21"	42"	21"	22"	N/A	35"	36"	10
48" (47.68")	174" (173.68")	2	87"	21"	43 1/2"	21 3/4"	22"	N/A	36"	38"	10
	180" (179.68")	2	90"	21"	45"	22 1/2"	22"	N/A	38"	39"	10
	126" (125.68")	2	63"	24"	31 1/2"	15 3/4"	27"	51"	N/A	N/A	6
	132" (131.68")	2	66"	24"	33"	16 1/2"	27"	54"	N/A	N/A	6
	138" (137.68")	2	69"	24"	34 1/2"	17 1/4"	27"	57"	N/A	N/A	6
	144" (143.68")	2	72"	24"	36"	18"	27"	60"	N/A	N/A	6
	150" (149.68")	2	75"	24"	37 1/2"	18 3/4"	27"	N/A	30"	32"	10
	156" (155.68")	2	78"	24"	39"	19 1/2"	27"	N/A	32"	33"	10
54" (53.68")	162" (161.68")	2	81"	24"	40 1/2"	20 1/4"	27"	N/A	33"	35"	10
	168" (167.68")	2	84"	24"	42"	21"	27"	N/A	35"	36"	10
	174" (173.68")	2	87"	24"	43 1/2"	21 3/4"	27"	N/A	36"	38"	10
	180" (179.68")	2	90"	24"	45"	22 1/2"	27"	N/A	38"	39"	10
	126" (125.68")	2	63"	27"	31 1/2"	15 3/4"	32"	51"	N/A	N/A	6
	132" (131.68")	2	66"	27"	33"	16 1/2"	32"	54"	N/A	N/A	6
	138" (137.68")	2	69"	27"	34 1/2"	17 1/4"	32"	57"	N/A	N/A	6
	144" (143.68")	2	72"	27"	36"	18"	32"	60"	N/A	N/A	6
60" (59.68")	150" (149.68")	2	75"	27"	37 1/2"	18 3/4"	32"	N/A	30"	32"	10
	156" (155.68")	2	78"	27"	39"	19 1/2"	32"	N/A	32"	33"	10
	162" (161.68")	2	81"	27"	40 1/2"	20 1/4"	32"	N/A	33"	35"	10
	168" (167.68")	2	84"	27"	42"	21"	32"	N/A	35"	36"	10
	174" (173.68")	2	87"	27"	43 1/2"	21 3/4"	32"	N/A	36"	38"	10
	180" (179.68")	2	90"	27"	45"	22 1/2"	32"	N/A	38"	39"	10
	126" (125.68")	2	63"	30"	31 1/2"	15 3/4"	36"	51"	N/A	N/A	6
	132" (131.68")	2	66"	30"	33"	16 1/2"	36"	54"	N/A	N/A	6
138" (137.68")	2	69"	30"	34 1/2"	17 1/4"	36"	57"	N/A	N/A	6	
144" (143.68")	2	72"	30"	36"	18"	36"	60"	N/A	N/A	6	
150" (149.68")	2	75"	30"	37 1/2"	18 3/4"	36"	N/A	30"	32"	10	
156" (155.68")	2	78"	30"	39"	19 1/2"	36"	N/A	32"	33"	10	
162" (161.68")	2	81"	30"	40 1/2"	20 1/4"	36"	N/A	33"	35"	10	
168" (167.68")	2	84"	30"	42"	21"	36"	N/A	35"	36"	10	
174" (173.68")	2	87"	30"	43 1/2"	21 3/4"	36"	N/A	36"	38"	10	
180" (179.68")	2	90"	30"	45"	22 1/2"	36"	N/A	38"	39"	10	

Product Details – Planes Interior Leg Conference Tables

Pebble (Two-Piece Top)

Dimensions – 126"-144" Wide
Tables With Cable Base
Includes (4) Legs

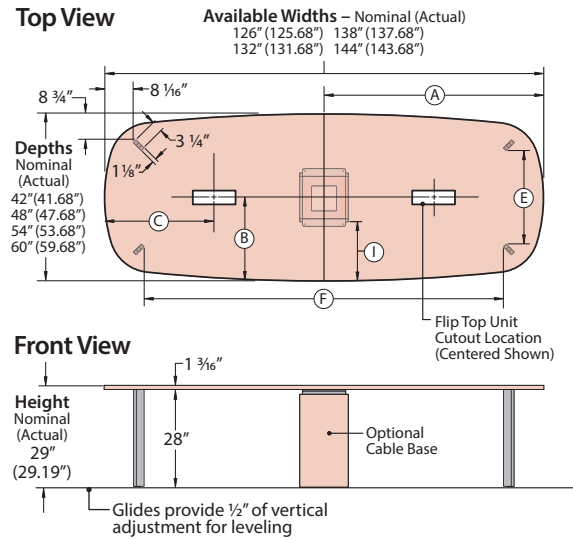
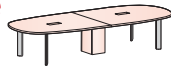

Dimensions – 150"-180" Wide
Tables With Cable Base
Includes (8) Legs

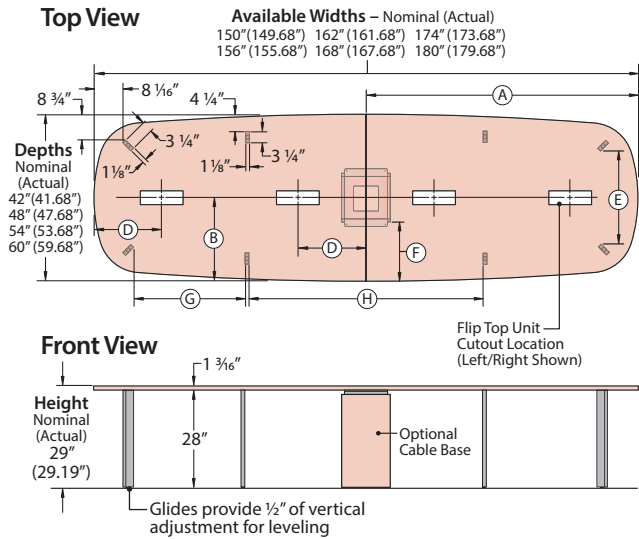
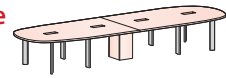

Dimensions

Depth Nominal (Actual)	TABLETOP						KNEESPACE (Nominal)					LEGS Number of Legs With Cable Base	CABLE BASE Optional Cable Base Sizes
	Width Nominal (Actual)	Number of Top Pieces	A	B	C	D	E	F	G	H	I		
42" (41.68")	126" (125.68")	2	63"	21"	31 1/2"	15 3/4"	22"	104"	N/A	N/A	14"	4	14" D x 14" W
	132" (131.68")	2	66"	21"	33"	16 1/2"	22"	110"	N/A	N/A	14"	4	14" D x 14" W
	138" (137.68")	2	69"	21"	34 1/2"	17 1/4"	22"	116"	N/A	N/A	14"	4	14" D x 14" W
	144" (143.68")	2	72"	21"	36"	18"	22"	122"	N/A	N/A	14"	4	14" D x 14" W
	150" (149.68")	2	75"	21"	37 1/2"	18 3/4"	22"	N/A	30"	66"	14"	8	14" D x 14" W
	156" (155.68")	2	78"	21"	39"	19 1/2"	22"	N/A	32"	68"	14"	8	14" D x 14" W
	162" (161.68")	2	81"	21"	40 1/2"	20 1/4"	22"	N/A	33"	72"	14"	8	14" D x 14" W
	168" (167.68")	2	84"	21"	42"	21"	22"	N/A	35"	74"	14"	8	14" D x 14" W
	174" (173.68")	2	87"	21"	43 1/2"	21 3/4"	22"	N/A	36"	78"	14"	8	14" D x 14" W
48" (47.68")	180" (179.68")	2	90"	21"	45"	22 1/2"	22"	N/A	38"	80"	14"	8	14" D x 14" W
	126" (125.68")	2	63"	24"	31 1/2"	15 3/4"	27"	104"	N/A	N/A	17"	4	14" D x 14" W
	132" (131.68")	2	66"	24"	33"	16 1/2"	27"	110"	N/A	N/A	17"	4	14" D x 14" W
	138" (137.68")	2	69"	24"	34 1/2"	17 1/4"	27"	116"	N/A	N/A	17"	4	14" D x 14" W
	144" (143.68")	2	72"	24"	36"	18"	27"	122"	N/A	N/A	17"	4	14" D x 14" W
	150" (149.68")	2	75"	24"	37 1/2"	18 3/4"	27"	N/A	30"	66"	17"	8	14" D x 14" W
	156" (155.68")	2	78"	24"	39"	19 1/2"	27"	N/A	32"	68"	17"	8	14" D x 14" W
	162" (161.68")	2	81"	24"	40 1/2"	20 1/4"	27"	N/A	33"	72"	17"	8	14" D x 14" W
	168" (167.68")	2	84"	24"	42"	21"	27"	N/A	35"	74"	17"	8	14" D x 14" W
54" (53.68")	174" (173.68")	2	87"	24"	43 1/2"	21 3/4"	27"	N/A	36"	78"	17"	8	14" D x 14" W
	180" (179.68")	2	90"	24"	45"	22 1/2"	27"	N/A	38"	80"	17"	8	14" D x 14" W
	126" (125.68")	2	63"	27"	31 1/2"	15 3/4"	32"	104"	N/A	N/A	20"	4	14" D x 14" W
	132" (131.68")	2	66"	27"	33"	16 1/2"	32"	110"	N/A	N/A	20"	4	14" D x 14" W
	138" (137.68")	2	69"	27"	34 1/2"	17 1/4"	32"	116"	N/A	N/A	20"	4	14" D x 14" W
	144" (143.68")	2	72"	27"	36"	18"	32"	122"	N/A	N/A	20"	4	14" D x 14" W
	150" (149.68")	2	75"	27"	37 1/2"	18 3/4"	32"	N/A	30"	66"	20"	8	14" D x 14" W
	156" (155.68")	2	78"	27"	39"	19 1/2"	32"	N/A	32"	68"	20"	8	14" D x 14" W
	162" (161.68")	2	81"	27"	40 1/2"	20 1/4"	32"	N/A	33"	72"	20"	8	14" D x 14" W
60" (59.68")	168" (167.68")	2	84"	27"	42"	21"	32"	N/A	35"	74"	20"	8	14" D x 14" W
	174" (173.68")	2	87"	27"	43 1/2"	21 3/4"	32"	N/A	36"	78"	20"	8	14" D x 14" W
	180" (179.68")	2	90"	27"	45"	22 1/2"	32"	N/A	38"	80"	20"	8	14" D x 14" W
	126" (125.68")	2	63"	30"	31 1/2"	15 3/4"	36"	104"	N/A	N/A	23"	4	14" D x 14" W
	132" (131.68")	2	66"	30"	33"	16 1/2"	36"	110"	N/A	N/A	23"	4	14" D x 14" W
	138" (137.68")	2	69"	30"	34 1/2"	17 1/4"	36"	116"	N/A	N/A	23"	4	14" D x 14" W
	144" (143.68")	2	72"	30"	36"	18"	36"	122"	N/A	N/A	23"	4	14" D x 14" W
	150" (149.68")	2	75"	30"	37 1/2"	18 3/4"	36"	N/A	30"	66"	23"	8	14" D x 14" W
	156" (155.68")	2	78"	30"	39"	19 1/2"	36"	N/A	32"	68"	23"	8	14" D x 14" W
60" (59.68")	162" (161.68")	2	81"	30"	40 1/2"	20 1/4"	36"	N/A	33"	72"	23"	8	14" D x 14" W
	168" (167.68")	2	84"	30"	42"	21"	36"	N/A	35"	74"	23"	8	14" D x 14" W
	174" (173.68")	2	87"	30"	43 1/2"	21 3/4"	36"	N/A	36"	78"	23"	8	14" D x 14" W
	180" (179.68")	2	90"	30"	45"	22 1/2"	36"	N/A	38"	80"	23"	8	14" D x 14" W

Product Details – Planes Interior Leg Conference Tables

Pebble (Two-Piece Top)

Table Sizes and Seating Capacities – Without Cable Bases

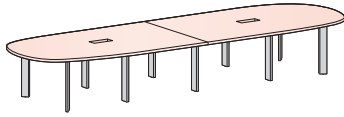

- 126", 132", 138" and 144" Wide Two-Piece Top Tables specified without a Cable Base are standard with 6 Legs.
- 150", 156", 162", 168", 174", 180" Wide Two-Piece Top Tables specified without a Cable Base are standard with 10 Legs.

		WIDTHS									
		126" Wide	132" Wide	138" Wide	144" Wide	150" Wide	156" Wide	162" Wide	168" Wide	174" Wide	180" Wide
DEPTHS	42" Deep	 10 Chairs Maximum (6 Legs)	 10 Chairs Maximum (6 Legs)	 10 Chairs Maximum (6 Legs)	 10 Chairs Maximum (6 Legs)	 10 Chairs Maximum (10 Legs)	 10 Chairs Maximum (10 Legs)	 10 Chairs Maximum (10 Legs)	 10 Chairs Maximum (10 Legs)	 10 Chairs Maximum (10 Legs)	 10 Chairs Maximum (10 Legs)
	48" Deep	 10 Chairs Maximum (6 Legs)	 10 Chairs Maximum (6 Legs)	 10 Chairs Maximum (6 Legs)	 10 Chairs Maximum (6 Legs)	 10 Chairs Maximum (10 Legs)	 10 Chairs Maximum (10 Legs)	 10 Chairs Maximum (10 Legs)	 10 Chairs Maximum (10 Legs)	 10 Chairs Maximum (10 Legs)	 10 Chairs Maximum (10 Legs)
	54" Deep	 10 Chairs Maximum (6 Legs)	 10 Chairs Maximum (6 Legs)	 10 Chairs Maximum (6 Legs)	 10 Chairs Maximum (6 Legs)	 10 Chairs Maximum (10 Legs)	 10 Chairs Maximum (10 Legs)	 10 Chairs Maximum (10 Legs)	 10 Chairs Maximum (10 Legs)	 10 Chairs Maximum (10 Legs)	 10 Chairs Maximum (10 Legs)
	60" Deep	 12 Chairs Maximum (6 Legs)	 12 Chairs Maximum (6 Legs)	 12 Chairs Maximum (6 Legs)	 12 Chairs Maximum (6 Legs)	 12 Chairs Maximum (10 Legs)	 12 Chairs Maximum (10 Legs)	 12 Chairs Maximum (10 Legs)	 12 Chairs Maximum (10 Legs)	 10 Chairs Maximum (10 Legs)	 10 Chairs Maximum (10 Legs)

Table Sizes and Seating Capacities – With Cable Bases

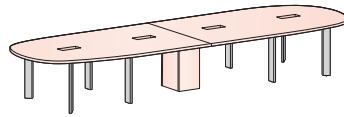

- 126", 132", 138" and 144" Wide Two-Piece Top Tables specified with a Cable Base are standard with 4 Legs.
- 150", 156", 162", 168", 174", 180" Wide Two-Piece Top Tables specified with a Cable Base are standard with 8 Legs.

		WIDTHS									
		126" Wide	132" Wide	138" Wide	144" Wide	150" Wide	156" Wide	162" Wide	168" Wide	174" Wide	180" Wide
DEPTHS	42" Deep	 10 Chairs Max. (4 Legs/ 1 Cable Base)	 10 Chairs Max. (4 Legs/ 1 Cable Base)	 10 Chairs Max. (4 Legs/ 1 Cable Base)	 10 Chairs Max. (4 Legs/ 1 Cable Base)	 10 Chairs Max. (8 Legs/ 1 Cable Base)	 10 Chairs Max. (8 Legs/ 1 Cable Base)	 10 Chairs Max. (8 Legs/ 1 Cable Base)	 12 Chairs Max. (8 Legs/ 1 Cable Base)	 12 Chairs Max. (8 Legs/ 1 Cable Base)	 12 Chairs Max. (8 Legs/ 1 Cable Base)
	48" Deep	 10 Chairs Max. (4 Legs/ 1 Cable Base)	 10 Chairs Max. (4 Legs/ 1 Cable Base)	 10 Chairs Max. (4 Legs/ 1 Cable Base)	 10 Chairs Max. (4 Legs/ 1 Cable Base)	 10 Chairs Max. (8 Legs/ 1 Cable Base)	 10 Chairs Max. (8 Legs/ 1 Cable Base)	 10 Chairs Max. (8 Legs/ 1 Cable Base)	 12 Chairs Max. (8 Legs/ 1 Cable Base)	 12 Chairs Max. (8 Legs/ 1 Cable Base)	 12 Chairs Max. (8 Legs/ 1 Cable Base)
	54" Deep	 10 Chairs Max. (4 Legs/ 1 Cable Base)	 10 Chairs Max. (4 Legs/ 1 Cable Base)	 10 Chairs Max. (4 Legs/ 1 Cable Base)	 10 Chairs Max. (4 Legs/ 1 Cable Base)	 10 Chairs Max. (8 Legs/ 1 Cable Base)	 10 Chairs Max. (8 Legs/ 1 Cable Base)	 10 Chairs Max. (8 Legs/ 1 Cable Base)	 12 Chairs Max. (8 Legs/ 1 Cable Base)	 12 Chairs Max. (8 Legs/ 1 Cable Base)	 12 Chairs Max. (8 Legs/ 1 Cable Base)
	60" Deep	 10 Chairs Max. (4 Legs/ 1 Cable Base)	 10 Chairs Max. (4 Legs/ 1 Cable Base)	 10 Chairs Max. (4 Legs/ 1 Cable Base)	 10 Chairs Max. (4 Legs/ 1 Cable Base)	 10 Chairs Max. (8 Legs/ 1 Cable Base)	 10 Chairs Max. (8 Legs/ 1 Cable Base)	 10 Chairs Max. (8 Legs/ 1 Cable Base)	 12 Chairs Max. (8 Legs/ 1 Cable Base)	 12 Chairs Max. (8 Legs/ 1 Cable Base)	 12 Chairs Max. (8 Legs/ 1 Cable Base)

Note Recommended seating capacity based upon a width of 27" per chair.

Product Details – Planes Interior Leg Conference Tables

Hexagon (Two-Piece Top)

Without Cable Base – Includes (10) Legs

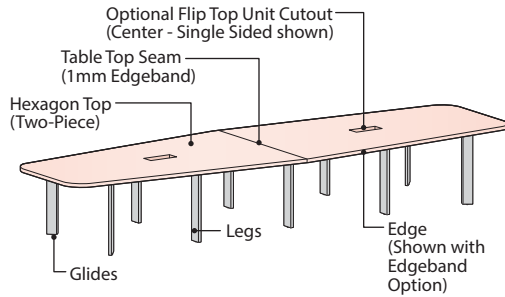

With Cable Base – Includes (8) Legs

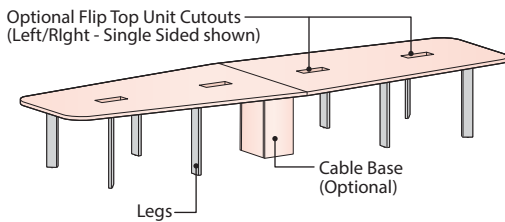

Edge Options for Laminate Tops

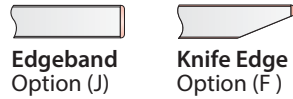

Edge Options for Wood Tops

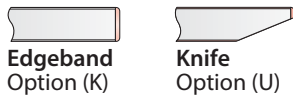

Component Materials/Finishes

COMPONENT NAME		MATERIALS/ FINISHES
Hexagon Top	2-Piece top with 1mm edgeband seam	Laminate Top – Specify separate finish colors for top and edge trim • Edge Options: (T) T-Mold, (J) Edgeband, (F) Knife
		Wood Top – Specify a single finish color for the top and edge trim • Edge Options: (K) Edgeband, (M) Cascade, (U) Knife
Interior Legs		Painted Metal – Specified Trim Color
Glides		Standard in Black
Cable Base (Optional)	Panels	Laminate Panels – Specified surface and edge trim colors Wood Panels – Specified top and edge trim wood finish color
	Frame	Painted Metal – Standard in Black

Flip Top Unit Cutout Options

Center Cutout Option

- Includes 3 Flip Top Unit cutouts (1 Cutout centered on each top piece)

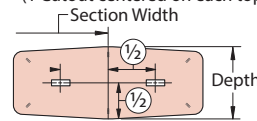

Left/Right Cutout Option

- Includes 6 Flip Top Unit cutouts (2 Cutouts on each top piece)

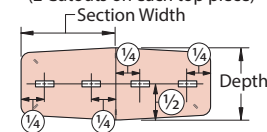

Cutout Option (F or V)

- For use with Single Sided/ 4 Port Flip Top Unit

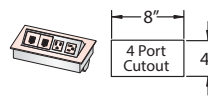

Cutout Option (J or K)

- For use with Single Sided/ 6 Port Flip Top Unit

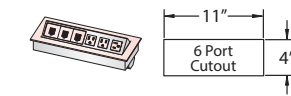

Cutout Option (M or P)

- For use with Double Sided/ 8 1/2 Ports Flip Top Unit

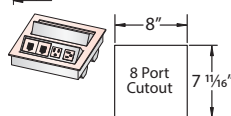

Cutout Option (Q or T)

- For use with Double Sided/ 12 Ports Flip Top Unit

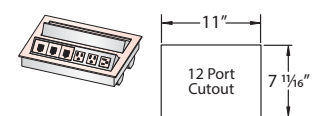

Note Flip Top Units are separately specified.

Cable Base Options

- Tables may be specified with or without Cable Bases
 - (Option N) No Cable Base.
 - (Option C) Includes (2) 14" x 14" Cable Bases

Two-Piece Table with Cable Base option (Top View)

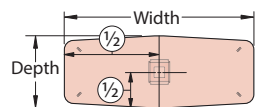

Cable Base is centered on the seam between top pieces.

14" x 14" Cable Base (42", 48", 54", 60" Deep Tables)

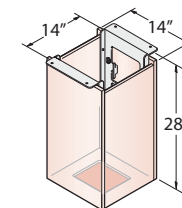

Product Details – Planes Interior Leg Conference Tables

Hexagon (Two-Piece Top)

**Dimensions – 126"-144" Wide
Tables Without Cable Base
Includes (6) Legs**

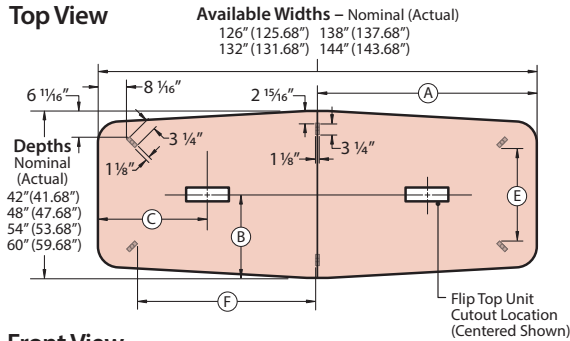
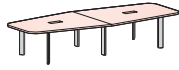

**Dimensions – 150"-180" Wide
Tables Without Cable Base
Includes (10) Legs**

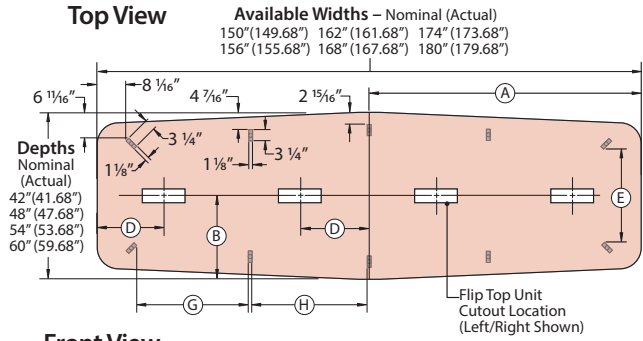
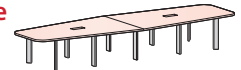

Dimensions

Depth Nominal (Actual)	TABLETOP						KNEESPACE (Nominal)				Number of Legs Without Cable Base
	Width Nominal (Actual)	Number of Top Pieces	A	B	C	D	E	F	G	H	
42" (41.68")	126" (125.68")	2	63"	21"	31 1/2"	15 3/4"	22"	51"	N/A	N/A	6
	132" (131.68")	2	66"	21"	33"	16 1/2"	22"	54"	N/A	N/A	6
	138" (137.68")	2	69"	21"	34 1/2"	17 1/4"	22"	57"	N/A	N/A	6
	144" (143.68")	2	72"	21"	36"	18"	22"	60"	N/A	N/A	6
	150" (149.68")	2	75"	21"	37 1/2"	18 3/4"	22"	N/A	30"	31"	10
	156" (155.68")	2	78"	21"	39"	19 1/2"	22"	N/A	32"	33"	10
	162" (161.68")	2	81"	21"	40 1/2"	20 1/4"	22"	N/A	33"	34"	10
	168" (167.68")	2	84"	21"	42"	21"	22"	N/A	35"	36"	10
	174" (173.68")	2	87"	21"	43 1/2"	21 3/4"	22"	N/A	36"	37"	10
48" (47.68")	180" (179.68")	2	90"	21"	45"	22 1/2"	22"	N/A	38"	39"	10
	126" (125.68")	2	63"	24"	31 1/2"	15 3/4"	28"	51"	N/A	N/A	6
	132" (131.68")	2	66"	24"	33"	16 1/2"	28"	54"	N/A	N/A	6
	138" (137.68")	2	69"	24"	34 1/2"	17 1/4"	28"	57"	N/A	N/A	6
	144" (143.68")	2	72"	24"	36"	18"	28"	60"	N/A	N/A	6
	150" (149.68")	2	75"	24"	37 1/2"	18 3/4"	28"	N/A	30"	31"	10
	156" (155.68")	2	78"	24"	39"	19 1/2"	28"	N/A	32"	33"	10
	162" (161.68")	2	81"	24"	40 1/2"	20 1/4"	28"	N/A	33"	34"	10
	168" (167.68")	2	84"	24"	42"	21"	28"	N/A	35"	36"	10
54" (53.68")	174" (173.68")	2	87"	24"	43 1/2"	21 3/4"	28"	N/A	36"	37"	10
	180" (179.68")	2	90"	24"	45"	22 1/2"	28"	N/A	38"	39"	10
	126" (125.68")	2	63"	27"	31 1/2"	15 3/4"	34"	51"	N/A	N/A	6
	132" (131.68")	2	66"	27"	33"	16 1/2"	34"	54"	N/A	N/A	6
	138" (137.68")	2	69"	27"	34 1/2"	17 1/4"	34"	57"	N/A	N/A	6
	144" (143.68")	2	72"	27"	36"	18"	34"	60"	N/A	N/A	6
	150" (149.68")	2	75"	27"	37 1/2"	18 3/4"	34"	N/A	30"	31"	10
	156" (155.68")	2	78"	27"	39"	19 1/2"	34"	N/A	32"	33"	10
	162" (161.68")	2	81"	27"	40 1/2"	20 1/4"	34"	N/A	33"	34"	10
60" (59.68")	168" (167.68")	2	84"	27"	42"	21"	34"	N/A	35"	36"	10
	174" (173.68")	2	87"	27"	43 1/2"	21 3/4"	34"	N/A	36"	37"	10
	180" (179.68")	2	90"	27"	45"	22 1/2"	34"	N/A	38"	39"	10
	126" (125.68")	2	63"	30"	31 1/2"	15 3/4"	40"	51"	N/A	N/A	6
	132" (131.68")	2	66"	30"	33"	16 1/2"	40"	54"	N/A	N/A	6
	138" (137.68")	2	69"	30"	34 1/2"	17 1/4"	40"	57"	N/A	N/A	6
	144" (143.68")	2	72"	30"	36"	18"	40"	60"	N/A	N/A	6
	150" (149.68")	2	75"	30"	37 1/2"	18 3/4"	40"	N/A	30"	31"	10
	156" (155.68")	2	78"	30"	39"	19 1/2"	40"	N/A	32"	33"	10
162" (161.68")	2	81"	30"	40 1/2"	20 1/4"	40"	N/A	33"	34"	10	
168" (167.68")	2	84"	30"	42"	21"	40"	N/A	35"	36"	10	
174" (173.68")	2	87"	30"	43 1/2"	21 3/4"	40"	N/A	36"	37"	10	
180" (179.68")	2	90"	30"	45"	22 1/2"	40"	N/A	38"	39"	10	

Product Details – Planes Interior Leg Conference Tables

Hexagon (Two-Piece Top)

Dimensions – 126"-144" Wide
Tables With Cable Base
Includes (4) Legs

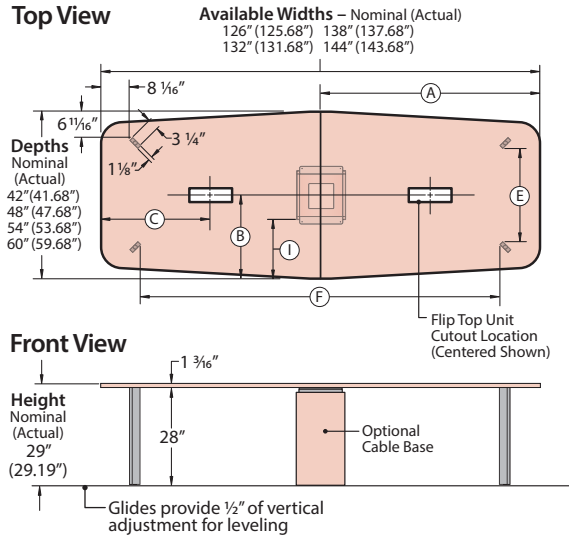
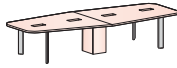

Dimensions – 150"-180" Wide
Tables With Cable Base
Includes (8) Legs

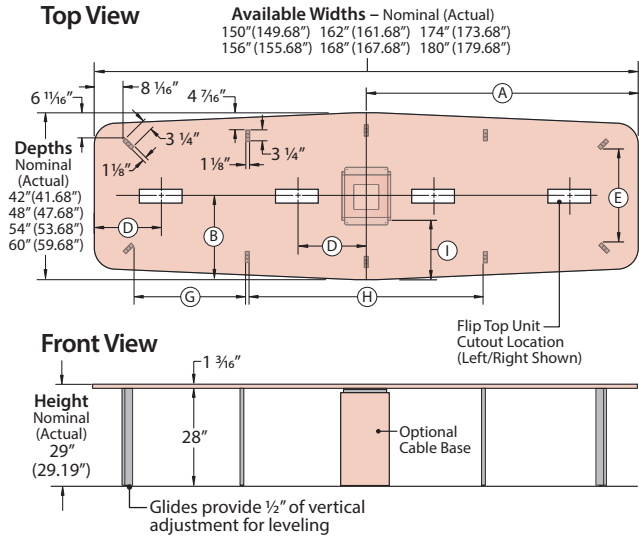
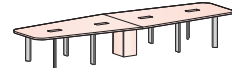

Dimensions

Depth Nominal (Actual)	TABLETOP						KNEESPACE (Nominal)					LEGS	CABLE BASE
	Width Nominal (Actual)	Number of Top Pieces	A	B	C	D	E	F	G	H	I	Number of Legs With Cable Base	Optional Cable Base Sizes
42" (41.68")	126" (125.68")	2	63"	21"	31 1/2"	15 3/4"	22"	104"	N/A	N/A	14"	4	14" D x 14" W
	132" (131.68")	2	66"	21"	33"	16 1/2"	22"	110"	N/A	N/A	14"	4	14" D x 14" W
	138" (137.68")	2	69"	21"	34 1/2"	17 1/4"	22"	116"	N/A	N/A	14"	4	14" D x 14" W
	144" (143.68")	2	72"	21"	36"	18"	22"	122"	N/A	N/A	14"	4	14" D x 14" W
	150" (149.68")	2	75"	21"	37 1/2"	18 3/4"	22"	N/A	30"	64"	14"	8	14" D x 14" W
	156" (155.68")	2	78"	21"	39"	19 1/2"	22"	N/A	32"	68"	14"	8	14" D x 14" W
	162" (161.68")	2	81"	21"	40 1/2"	20 1/4"	22"	N/A	33"	70"	14"	8	14" D x 14" W
	168" (167.68")	2	84"	21"	42"	21"	22"	N/A	35"	74"	14"	8	14" D x 14" W
	174" (173.68")	2	87"	21"	43 1/2"	21 3/4"	22"	N/A	36"	76"	14"	8	14" D x 14" W
180" (179.68")	2	90"	21"	45"	22 1/2"	22"	N/A	38"	80"	14"	8	14" D x 14" W	
48" (47.68")	126" (125.68")	2	63"	24"	31 1/2"	15 3/4"	28"	104"	N/A	N/A	17"	4	14" D x 14" W
	132" (131.68")	2	66"	24"	33"	16 1/2"	28"	110"	N/A	N/A	17"	4	14" D x 14" W
	138" (137.68")	2	69"	24"	34 1/2"	17 1/4"	28"	116"	N/A	N/A	17"	4	14" D x 14" W
	144" (143.68")	2	72"	24"	36"	18"	28"	122"	N/A	N/A	17"	4	14" D x 14" W
	150" (149.68")	2	75"	24"	37 1/2"	18 3/4"	28"	N/A	30"	64"	17"	8	14" D x 14" W
	156" (155.68")	2	78"	24"	39"	19 1/2"	28"	N/A	32"	68"	17"	8	14" D x 14" W
	162" (161.68")	2	81"	24"	40 1/2"	20 1/4"	28"	N/A	33"	70"	17"	8	14" D x 14" W
	168" (167.68")	2	84"	24"	42"	21"	28"	N/A	35"	74"	17"	8	14" D x 14" W
	174" (173.68")	2	87"	24"	43 1/2"	21 3/4"	28"	N/A	36"	76"	17"	8	14" D x 14" W
180" (179.68")	2	90"	24"	45"	22 1/2"	28"	N/A	38"	80"	17"	8	14" D x 14" W	
54" (53.68")	126" (125.68")	2	63"	27"	31 1/2"	15 3/4"	34"	104"	N/A	N/A	20"	4	14" D x 14" W
	132" (131.68")	2	66"	27"	33"	16 1/2"	34"	110"	N/A	N/A	20"	4	14" D x 14" W
	138" (137.68")	2	69"	27"	34 1/2"	17 1/4"	34"	116"	N/A	N/A	20"	4	14" D x 14" W
	144" (143.68")	2	72"	27"	36"	18"	34"	122"	N/A	N/A	20"	4	14" D x 14" W
	150" (149.68")	2	75"	27"	37 1/2"	18 3/4"	34"	N/A	30"	64"	20"	8	14" D x 14" W
	156" (155.68")	2	78"	27"	39"	19 1/2"	34"	N/A	32"	68"	20"	8	14" D x 14" W
	162" (161.68")	2	81"	27"	40 1/2"	20 1/4"	34"	N/A	33"	70"	20"	8	14" D x 14" W
	168" (167.68")	2	84"	27"	42"	21"	34"	N/A	35"	74"	20"	8	14" D x 14" W
	174" (173.68")	2	87"	27"	43 1/2"	21 3/4"	34"	N/A	36"	76"	20"	8	14" D x 14" W
180" (179.68")	2	90"	27"	45"	22 1/2"	34"	N/A	38"	80"	20"	8	14" D x 14" W	
60" (59.68")	126" (125.68")	2	63"	30"	31 1/2"	15 3/4"	40"	104"	N/A	N/A	23"	4	14" D x 14" W
	132" (131.68")	2	66"	30"	33"	16 1/2"	40"	110"	N/A	N/A	23"	4	14" D x 14" W
	138" (137.68")	2	69"	30"	34 1/2"	17 1/4"	40"	116"	N/A	N/A	23"	4	14" D x 14" W
	144" (143.68")	2	72"	30"	36"	18"	40"	122"	N/A	N/A	23"	4	14" D x 14" W
	150" (149.68")	2	75"	30"	37 1/2"	18 3/4"	40"	N/A	30"	64"	23"	8	14" D x 14" W
	156" (155.68")	2	78"	30"	39"	19 1/2"	40"	N/A	32"	68"	23"	8	14" D x 14" W
	162" (161.68")	2	81"	30"	40 1/2"	20 1/4"	40"	N/A	33"	70"	23"	8	14" D x 14" W
	168" (167.68")	2	84"	30"	42"	21"	40"	N/A	35"	74"	23"	8	14" D x 14" W
	174" (173.68")	2	87"	30"	43 1/2"	21 3/4"	40"	N/A	36"	76"	23"	8	14" D x 14" W
180" (179.68")	2	90"	30"	45"	22 1/2"	40"	N/A	38"	80"	23"	8	14" D x 14" W	

Product Details – Planes Interior Leg Conference Tables

Hexagon (Two-Piece Top)

Table Sizes and Seating Capacities – Without Cable Bases

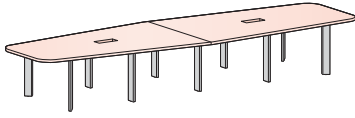

- 126", 132", 138" and 144" Wide Two-Piece Top Tables specified without a Cable Base are standard with 6 Legs.
- 150", 156", 162", 168", 174", 180" Wide Two-Piece Top Tables specified without a Cable Base are standard with 10 Legs.

		WIDTHS									
		126" Wide	132" Wide	138" Wide	144" Wide	150" Wide	156" Wide	162" Wide	168" Wide	174" Wide	180" Wide
DEPTHS	42" Deep										
	48" Deep										
	54" Deep										
	60" Deep										

Table Sizes and Seating Capacities – With Cable Bases

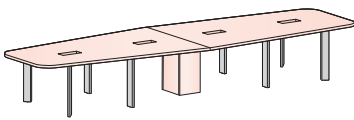

- 126", 132", 138" and 144" Wide Two-Piece Top Tables specified with a Cable Base are standard with 4 Legs.
- 150", 156", 162", 168", 174", 180" Wide Two-Piece Top Tables specified with a Cable Base are standard with 8 Legs.

		WIDTHS									
		126" Wide	132" Wide	138" Wide	144" Wide	150" Wide	156" Wide	162" Wide	168" Wide	174" Wide	180" Wide
DEPTHS	42" Deep										
	48" Deep										
	54" Deep										
	60" Deep										

Note Recommended seating capacity based upon a width of 27" per chair.

Product Details – Planes Interior Leg Conference Tables

Rectangular (Three-Piece Top)

Without Cable Base

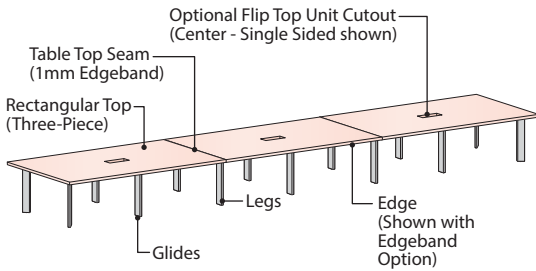

With Cable Base

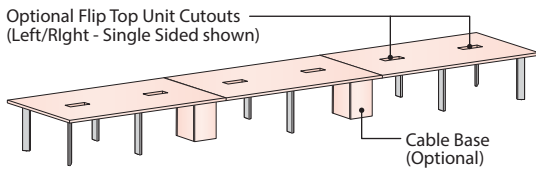

Edge Options for Laminate Tops

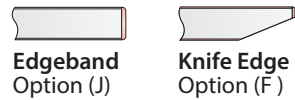

Edge Options for Wood Tops

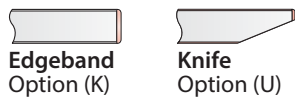

Component Materials/Finishes

COMPONENT NAME	MATERIALS/ FINISHES				
Rectangle Top 2-Piece top with 1mm edgeband seams	Laminate Top – Specify separate finish colors for top and edge trim • Edge Options: (T) T-Mold, (J) Edgeband, (F) Knife				
	Wood Top – Specify a single finish color for the top and edge trim • Edge Options: (K) Edgeband, (M) Cascade, (U) Knife				
Interior Legs	Painted Metal – Specified Trim Color				
Glides	Standard in Black				
Cable Base (Optional)	<table border="1"> <tr> <td>Panels</td> <td>Laminate Panels – Specified surface and edge trim colors</td> </tr> <tr> <td>Wood Panels</td> <td>– Specified top and edge trim wood finish color</td> </tr> </table>	Panels	Laminate Panels – Specified surface and edge trim colors	Wood Panels	– Specified top and edge trim wood finish color
	Panels	Laminate Panels – Specified surface and edge trim colors			
Wood Panels	– Specified top and edge trim wood finish color				
Frame	Painted Metal – Standard in Black				

Flip Top Unit Cutout Options

Center Cutout Option

- Includes 3 Flip Top Unit cutouts (1 Cutout centered on each top piece)

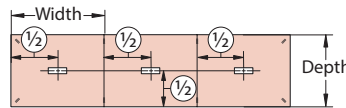

Left/Right Cutout Option

- Includes 6 Flip Top Unit cutouts (2 Cutouts on each top piece)

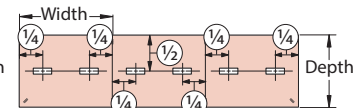

Cutout Option (F or V)

- For use with Single Sided/ 4 Port Flip Top Unit

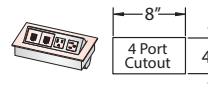

Cutout Option (J or K)

- For use with Single Sided/ 6 Ports Flip Top Unit

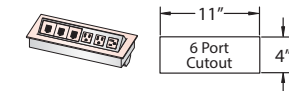

Cutout Option (M or P)

- For use with Double Sided/ 8 Ports Flip Top Unit

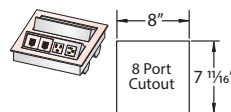

Cutout Option (Q or T)

- For use with Double Sided/ 12 Ports Flip Top Unit

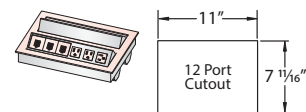

Note Flip Top Units are separately specified.

Cable Base Options

- Tables may be specified with or without Cable Bases
 - (Option N) No Cable Base.
 - (Option C) Includes (2) 14" x 14" Cable Bases

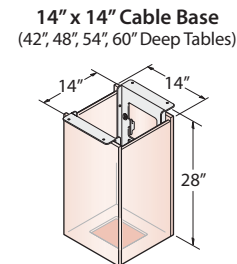
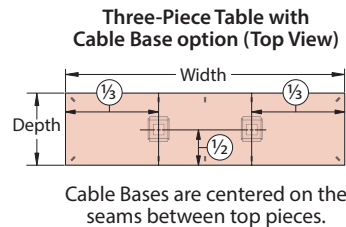

Product Details – Planes Interior Leg Conference Tables

Rectangular (Three-Piece Top)

Dimensions – 186"-198" Wide
Tables Without Cable Base
Includes (8) Legs

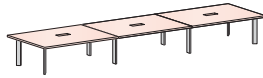

Top View

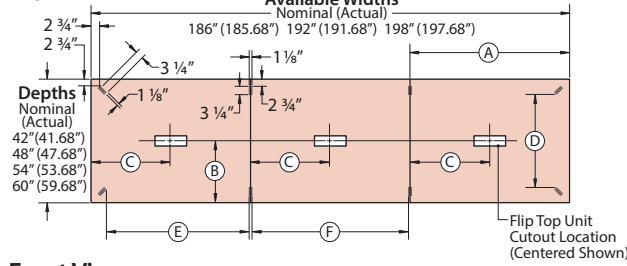

Front View

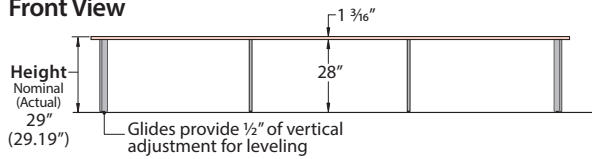

Dimensions – 204"-270" Wide
Tables Without Cable Base
Includes (14) Legs

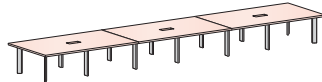

Top View

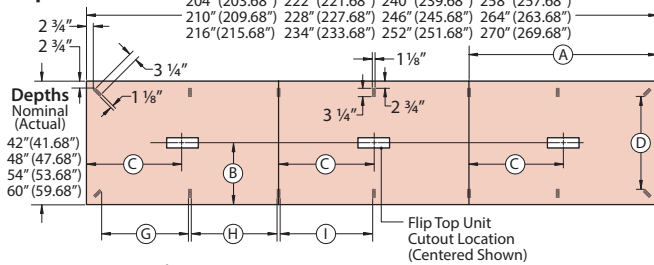

Front View

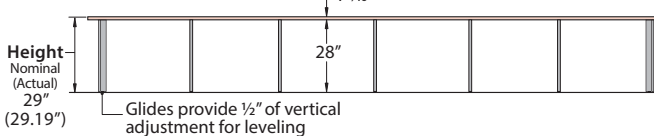

Dimensions

Depth Nominal (Actual)	TABLETOP			KNEESPACE (Nominal)									# of Legs Without Cable Base
	Width Nominal (Actual)	# of Top Pieces		A	B	C	D	E	F	G	H	I	
42" (41.68")	186" (185.68")	3	62"	21"	31"	27"	27"	60"	N/A	N/A	N/A	N/A	8
	192" (191.68")	3	64"	21"	32"	27"	33"	62"	N/A	N/A	N/A	N/A	8
	198" (197.68")	3	66"	21"	33"	27"	39"	64"	N/A	N/A	N/A	N/A	8
	204" (203.68")	3	68"	21"	34"	27"	N/A	N/A	26"	32"	32"	14	
	210" (209.68")	3	70"	21"	35"	27"	N/A	N/A	27"	33"	33"	14	
	216" (215.68")	3	72"	21"	36"	27"	N/A	N/A	28"	34"	34"	14	
	222" (221.68")	3	74"	21"	37"	27"	N/A	N/A	29"	35"	35"	14	
	228" (227.68")	3	76"	21"	38"	27"	N/A	N/A	30"	36"	36"	14	
	234" (233.68")	3	78"	21"	39"	27"	N/A	N/A	31"	37"	37"	14	
	240" (239.68")	3	80"	21"	40"	27"	N/A	N/A	32"	38"	38"	14	
	246" (245.68")	3	82"	21"	41"	27"	N/A	N/A	33"	39"	39"	14	
	252" (251.68")	3	84"	21"	42"	27"	N/A	N/A	34"	40"	40"	14	
	258" (257.68")	3	86"	21"	43"	27"	N/A	N/A	35"	41"	41"	14	
	264" (263.68")	3	88"	21"	44"	27"	N/A	N/A	36"	42"	42"	14	
270" (269.68")	3	90"	21"	45"	27"	N/A	N/A	37"	43"	43"	14		
48" (47.68")	186" (185.68")	3	62"	24"	31"	33"	27"	60"	N/A	N/A	N/A	N/A	8
	192" (191.68")	3	64"	24"	32"	33"	33"	62"	N/A	N/A	N/A	N/A	8
	198" (197.68")	3	66"	24"	33"	33"	39"	64"	N/A	N/A	N/A	N/A	8
	204" (203.68")	3	68"	24"	34"	33"	N/A	N/A	26"	32"	32"	14	
	210" (209.68")	3	70"	24"	35"	33"	N/A	N/A	27"	33"	33"	14	
	216" (215.68")	3	72"	24"	36"	33"	N/A	N/A	28"	34"	34"	14	
	222" (221.68")	3	74"	24"	37"	33"	N/A	N/A	29"	35"	35"	14	
	228" (227.68")	3	76"	24"	38"	33"	N/A	N/A	30"	36"	36"	14	
	234" (233.68")	3	78"	24"	39"	33"	N/A	N/A	31"	37"	37"	14	
	240" (239.68")	3	80"	24"	40"	33"	N/A	N/A	32"	38"	38"	14	
	246" (245.68")	3	82"	24"	41"	33"	N/A	N/A	33"	39"	39"	14	
	252" (251.68")	3	84"	24"	42"	33"	N/A	N/A	34"	40"	40"	14	
	258" (257.68")	3	86"	24"	43"	33"	N/A	N/A	35"	41"	41"	14	
	264" (263.68")	3	88"	24"	44"	33"	N/A	N/A	36"	42"	42"	14	
270" (269.68")	3	90"	24"	45"	33"	N/A	N/A	37"	43"	43"	14		
54" (53.68")	186" (185.68")	3	62"	27"	31"	39"	27"	60"	N/A	N/A	N/A	N/A	8
	192" (191.68")	3	64"	27"	32"	39"	33"	62"	N/A	N/A	N/A	N/A	8
	198" (197.68")	3	66"	27"	33"	39"	39"	64"	N/A	N/A	N/A	N/A	8
	204" (203.68")	3	68"	27"	34"	39"	N/A	N/A	26"	32"	32"	14	
	210" (209.68")	3	70"	27"	35"	39"	N/A	N/A	27"	33"	33"	14	
	216" (215.68")	3	72"	27"	36"	39"	N/A	N/A	28"	34"	34"	14	
	222" (221.68")	3	74"	27"	37"	39"	N/A	N/A	29"	35"	35"	14	
	228" (227.68")	3	76"	27"	38"	39"	N/A	N/A	30"	36"	36"	14	
	234" (233.68")	3	78"	27"	39"	39"	N/A	N/A	31"	37"	37"	14	
	240" (239.68")	3	80"	27"	40"	39"	N/A	N/A	32"	38"	38"	14	
	246" (245.68")	3	82"	27"	41"	39"	N/A	N/A	33"	39"	39"	14	
	252" (251.68")	3	84"	27"	42"	39"	N/A	N/A	34"	40"	40"	14	
	258" (257.68")	3	86"	27"	43"	39"	N/A	N/A	35"	41"	41"	14	
	264" (263.68")	3	88"	27"	44"	39"	N/A	N/A	36"	42"	42"	14	
270" (269.68")	3	90"	27"	45"	39"	N/A	N/A	37"	43"	43"	14		
60" (59.68")	186" (185.68")	3	62"	30"	31"	45"	27"	60"	N/A	N/A	N/A	N/A	8
	192" (191.68")	3	64"	30"	32"	45"	33"	62"	N/A	N/A	N/A	N/A	8
	198" (197.68")	3	66"	30"	33"	45"	39"	64"	N/A	N/A	N/A	N/A	8
	204" (203.68")	3	68"	30"	34"	45"	N/A	N/A	26"	32"	32"	14	
	210" (209.68")	3	70"	30"	35"	45"	N/A	N/A	27"	33"	33"	14	
	216" (215.68")	3	72"	30"	36"	45"	N/A	N/A	28"	34"	34"	14	
	222" (221.68")	3	74"	30"	37"	45"	N/A	N/A	29"	35"	35"	14	
	228" (227.68")	3	76"	30"	38"	45"	N/A	N/A	30"	36"	36"	14	
	234" (233.68")	3	78"	30"	39"	45"	N/A	N/A	31"	37"	37"	14	
	240" (239.68")	3	80"	30"	40"	45"	N/A	N/A	32"	38"	38"	14	
	246" (245.68")	3	82"	30"	41"	45"	N/A	N/A	33"	39"	39"	14	
	252" (251.68")	3	84"	30"	42"	45"	N/A	N/A	34"	40"	40"	14	
	258" (257.68")	3	86"	30"	43"	45"	N/A	N/A	35"	41"	41"	14	
	264" (263.68")	3	88"	30"	44"	45"	N/A	N/A	36"	42"	42"	14	
270" (269.68")	3	90"	30"	45"	45"	N/A	N/A	37"	43"	43"	14		

Product Details – Planes Interior Leg Conference Tables

Rectangular (Three-Piece Top)

Dimensions – 186"-198" Wide
Tables Without Cable Base
Includes (6) Legs

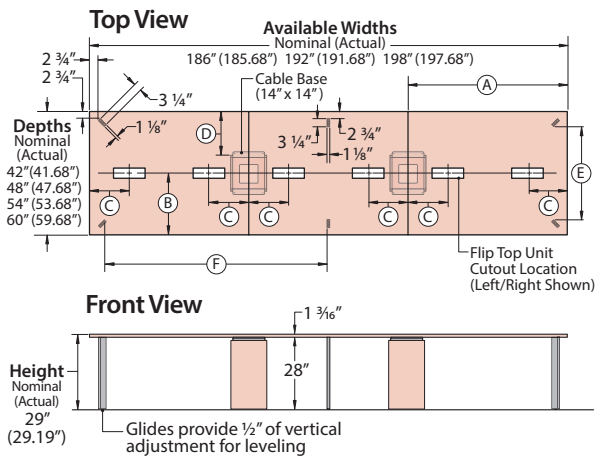

Dimensions – 204"-270" Wide
Tables Without Cable Base
Includes (10) Legs

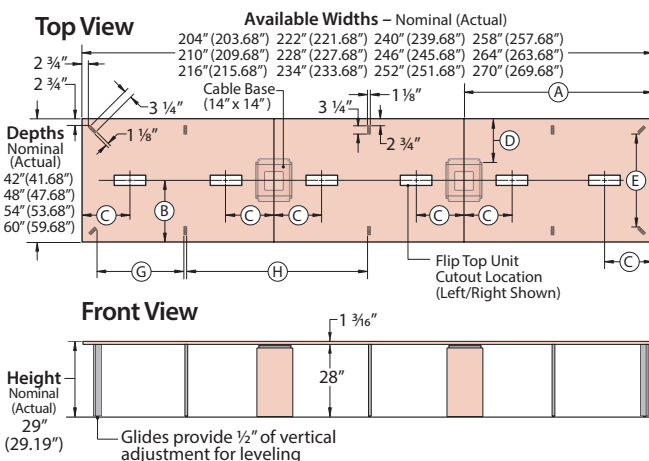

Dimensions

TABLETOP			KNEESPACE (Nominal)								# of Legs with (2) Cable Bases
Depth Nominal (Actual)	Width Nominal (Actual)	# of Top Pieces	A	B	C	D	E	F	G	H	
42" (41.68")	186"(185.68")	3	62"	21"	15 1/2"	14"	27"	85"	N/A	N/A	6
	192"(191.68")	3	64"	21"	16"	14"	27"	88"	N/A	N/A	6
	198"(197.68")	3	66"	21"	16 1/2"	14"	27"	91"	N/A	N/A	6
	204"(203.68")	3	68"	21"	17"	14"	27"	N/A	26"	66"	10
	210"(209.68")	3	70"	21"	17 1/2"	14"	27"	N/A	27"	68"	10
	216"(215.68")	3	72"	21"	18"	14"	27"	N/A	28"	70"	10
	222"(221.68")	3	74"	21"	18 1/2"	14"	27"	N/A	29"	72"	10
	228"(227.68")	3	76"	21"	19"	14"	27"	N/A	30"	74"	10
	234"(233.68")	3	78"	21"	19 1/2"	14"	27"	N/A	31"	76"	10
	240"(239.68")	3	80"	21"	20"	14"	27"	N/A	32"	78"	10
	246"(245.68")	3	82"	21"	20 1/2"	14"	27"	N/A	33"	80"	10
	252"(251.68")	3	84"	21"	21"	14"	27"	N/A	34"	82"	10
	258"(257.68")	3	86"	21"	21 1/2"	14"	27"	N/A	35"	84"	10
	264"(263.68")	3	88"	21"	22"	14"	27"	N/A	36"	86"	10
270"(269.68")	3	90"	21"	22 1/2"	14"	27"	N/A	37"	88"	10	
48" (47.68")	186"(185.68")	3	62"	24"	15 1/2"	17"	33"	85"	N/A	N/A	6
	192"(191.68")	3	64"	24"	16"	17"	33"	88"	N/A	N/A	6
	198"(197.68")	3	66"	24"	16 1/2"	17"	33"	91"	N/A	N/A	6
	204"(203.68")	3	68"	24"	17"	17"	33"	N/A	26"	66"	10
	210"(209.68")	3	70"	24"	17 1/2"	17"	33"	N/A	27"	68"	10
	216"(215.68")	3	72"	24"	18"	17"	33"	N/A	28"	70"	10
	222"(221.68")	3	74"	24"	18 1/2"	17"	33"	N/A	29"	72"	10
	228"(227.68")	3	76"	24"	19"	17"	33"	N/A	30"	74"	10
	234"(233.68")	3	78"	24"	19 1/2"	17"	33"	N/A	31"	76"	10
	240"(239.68")	3	80"	24"	20"	17"	33"	N/A	32"	78"	10
	246"(245.68")	3	82"	24"	20 1/2"	17"	33"	N/A	33"	80"	10
	252"(251.68")	3	84"	24"	21"	17"	33"	N/A	34"	82"	10
	258"(257.68")	3	86"	24"	21 1/2"	17"	33"	N/A	35"	84"	10
	264"(263.68")	3	88"	24"	22"	17"	33"	N/A	36"	86"	10
270"(269.68")	3	90"	24"	22 1/2"	17"	33"	N/A	37"	88"	10	
54" (53.68")	186"(185.68")	3	62"	27"	15 1/2"	20"	39"	85"	N/A	N/A	6
	192"(191.68")	3	64"	27"	16"	20"	39"	88"	N/A	N/A	6
	198"(197.68")	3	66"	27"	16 1/2"	20"	39"	91"	N/A	N/A	6
	204"(203.68")	3	68"	27"	17"	20"	39"	N/A	26"	66"	10
	210"(209.68")	3	70"	27"	17 1/2"	20"	39"	N/A	27"	68"	10
	216"(215.68")	3	72"	27"	18"	20"	39"	N/A	28"	70"	10
	222"(221.68")	3	74"	27"	18 1/2"	20"	39"	N/A	29"	72"	10
	228"(227.68")	3	76"	27"	19"	20"	39"	N/A	30"	74"	10
	234"(233.68")	3	78"	27"	19 1/2"	20"	39"	N/A	31"	76"	10
	240"(239.68")	3	80"	27"	20"	20"	39"	N/A	32"	78"	10
	246"(245.68")	3	82"	27"	20 1/2"	20"	39"	N/A	33"	80"	10
	252"(251.68")	3	84"	27"	21"	20"	39"	N/A	34"	82"	10
	258"(257.68")	3	86"	27"	21 1/2"	20"	39"	N/A	35"	84"	10
	264"(263.68")	3	88"	27"	22"	20"	39"	N/A	36"	86"	10
270"(269.68")	3	90"	27"	22 1/2"	20"	39"	N/A	37"	88"	10	
60" (59.68")	186"(185.68")	3	62"	30"	15 1/2"	23"	45"	85"	N/A	N/A	6
	192"(191.68")	3	64"	30"	16"	23"	45"	88"	N/A	N/A	6
	198"(197.68")	3	66"	30"	16 1/2"	23"	45"	91"	N/A	N/A	6
	204"(203.68")	3	68"	30"	17"	23"	45"	N/A	26"	66"	10
	210"(209.68")	3	70"	30"	17 1/2"	23"	45"	N/A	27"	68"	10
	216"(215.68")	3	72"	30"	18"	23"	45"	N/A	28"	70"	10
	222"(221.68")	3	74"	30"	18 1/2"	23"	45"	N/A	29"	72"	10
	228"(227.68")	3	76"	30"	19"	23"	45"	N/A	30"	74"	10
	234"(233.68")	3	78"	30"	19 1/2"	23"	45"	N/A	31"	76"	10
	240"(239.68")	3	80"	30"	20"	23"	45"	N/A	32"	78"	10
	246"(245.68")	3	82"	30"	20 1/2"	23"	45"	N/A	33"	80"	10
	252"(251.68")	3	84"	30"	21"	23"	45"	N/A	34"	82"	10
	258"(257.68")	3	86"	30"	21 1/2"	23"	45"	N/A	35"	84"	10
	264"(263.68")	3	88"	30"	22"	23"	45"	N/A	36"	86"	10
270"(269.68")	3	90"	30"	22 1/2"	23"	45"	N/A	37"	88"	10	

Product Details – Planes Interior Leg Conference Tables

Rectangular (Three-Piece Top)

Table Sizes and Seating Capacities – Without Cable Bases

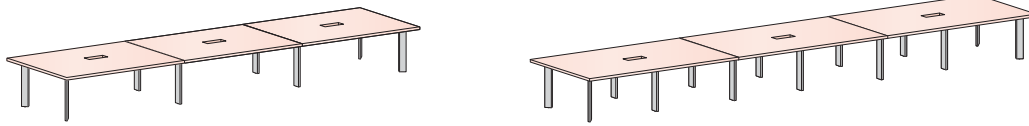

- 186", 192" and 198" Wide Three-Piece Top Tables specified without a Cable Base are standard with 8 Legs.
- 204", 210", 216", 222", 228", 234", 240", 246", 252", 258", 264" and 270" Wide Three-Piece Top Tables specified without a Cable Base are standard with 14 Legs.

		WIDTHS							
		186" Wide	192" Wide	198" Wide	204" Wide	210" Wide	216" Wide	222" Wide	228" Wide
DEPTHS	42" Deep								
	48" Deep	14 Chairs Maximum (8 Legs)	14 Chairs Maximum (8 Legs)	14 Chairs Maximum (8 Legs)	14 Chairs Maximum (14 Legs)	14 Chairs Maximum (14 Legs)	14 Chairs Maximum (14 Legs)	14 Chairs Maximum (14 Legs)	14 Chairs Maximum (14 Legs)
	54" Deep	14 Chairs Maximum (8 Legs)	14 Chairs Maximum (8 Legs)	14 Chairs Maximum (8 Legs)	14 Chairs Maximum (14 Legs)	14 Chairs Maximum (14 Legs)	14 Chairs Maximum (14 Legs)	14 Chairs Maximum (14 Legs)	14 Chairs Maximum (14 Legs)
	60" Deep	16 Chairs Maximum (8 Legs)	16 Chairs Maximum (8 Legs)	16 Chairs Maximum (8 Legs)	16 Chairs Maximum (14 Legs)	16 Chairs Maximum (14 Legs)	16 Chairs Maximum (14 Legs)	16 Chairs Maximum (14 Legs)	16 Chairs Maximum (14 Legs)

		WIDTHS						
		234" Wide	240" Wide	246" Wide	252" Wide	258" Wide	264" Wide	270" Wide
DEPTHS	42" Deep							
	48" Deep	14 Chairs Maximum (8 Legs)	14 Chairs Maximum (8 Legs)	14 Chairs Maximum (8 Legs)	14 Chairs Maximum (14 Legs)	14 Chairs Maximum (14 Legs)	14 Chairs Maximum (14 Legs)	14 Chairs Maximum (14 Legs)
	54" Deep	14 Chairs Maximum (8 Legs)	14 Chairs Maximum (8 Legs)	14 Chairs Maximum (8 Legs)	14 Chairs Maximum (14 Legs)	14 Chairs Maximum (14 Legs)	14 Chairs Maximum (14 Legs)	14 Chairs Maximum (14 Legs)
	60" Deep	16 Chairs Maximum (8 Legs)	16 Chairs Maximum (8 Legs)	16 Chairs Maximum (8 Legs)	16 Chairs Maximum (14 Legs)	16 Chairs Maximum (14 Legs)	16 Chairs Maximum (14 Legs)	16 Chairs Maximum (14 Legs)

Note Recommended seating capacity based upon a width of 27" per chair.

Product Details – Planes Interior Leg Conference Tables

Rectangular (Three-Piece Top)

Table Sizes and Seating Capacities – With Cable Bases

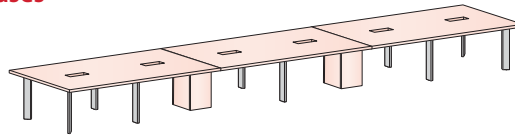
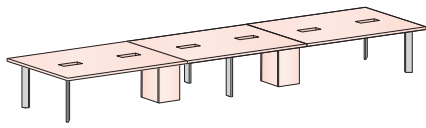

• 186", 192" and 198" Wide Three-Piece Top Tables specified with a Cable Base are standard with 2 Cable Bases and 6 Legs.

• 204", 210", 216", 222", 228", 234", 240", 246", 252", 258", 264" and 270" Wide Three-Piece Top Tables specified with a Cable Base are standard with 2 Cable Bases and 10 Legs.

		WIDTHS							
		186" Wide	192" Wide	198" Wide	204" Wide	210" Wide	216" Wide	222" Wide	228" Wide
DEPTHS	42" Deep								
	48" Deep	14 Chairs Maximum (6 Legs/2 Cable Bases)	14 Chairs Maximum (6 Legs/2 Cable Bases)	14 Chairs Maximum (6 Legs/2 Cable Bases)	14 Chairs Maximum (10 Legs/2 Cable Bases)	14 Chairs Maximum (10 Legs/2 Cable Bases)	14 Chairs Maximum (10 Legs/2 Cable Bases)	14 Chairs Maximum (10 Legs/2 Cable Bases)	14 Chairs Maximum (10 Legs/2 Cable Bases)
	54" Deep	14 Chairs Maximum (6 Legs/2 Cable Bases)	14 Chairs Maximum (6 Legs/2 Cable Bases)	14 Chairs Maximum (6 Legs/2 Cable Bases)	14 Chairs Maximum (10 Legs/2 Cable Bases)	14 Chairs Maximum (10 Legs/2 Cable Bases)	14 Chairs Maximum (10 Legs/2 Cable Bases)	14 Chairs Maximum (10 Legs/2 Cable Bases)	14 Chairs Maximum (10 Legs/2 Cable Bases)
	60" Deep	16 Chairs Maximum (6 Legs/2 Cable Bases)	16 Chairs Maximum (6 Legs/2 Cable Bases)	16 Chairs Maximum (6 Legs/2 Cable Bases)	16 Chairs Maximum (10 Legs/2 Cable Bases)	16 Chairs Maximum (10 Legs/2 Cable Bases)	16 Chairs Maximum (10 Legs/2 Cable Bases)	16 Chairs Maximum (10 Legs/2 Cable Bases)	16 Chairs Maximum (10 Legs/2 Cable Bases)

		WIDTHS						
		234" Wide	240" Wide	246" Wide	252" Wide	258" Wide	264" Wide	270" Wide
DEPTHS	42" Deep							
	48" Deep	14 Chairs Maximum (10 Legs/2 Cable Bases)	18 Chairs Maximum (10 Legs/2 Cable Bases)	18 Chairs Maximum (10 Legs/2 Cable Bases)	18 Chairs Maximum (10 Legs/2 Cable Bases)	18 Chairs Maximum (10 Legs/2 Cable Bases)	18 Chairs Maximum (10 Legs/2 Cable Bases)	18 Chairs Maximum (10 Legs/2 Cable Bases)
	54" Deep	14 Chairs Maximum (10 Legs/2 Cable Bases)	18 Chairs Maximum (10 Legs/2 Cable Bases)	18 Chairs Maximum (10 Legs/2 Cable Bases)	18 Chairs Maximum (10 Legs/2 Cable Bases)	18 Chairs Maximum (10 Legs/2 Cable Bases)	18 Chairs Maximum (10 Legs/2 Cable Bases)	18 Chairs Maximum (10 Legs/2 Cable Bases)
	60" Deep	16 Chairs Maximum (10 Legs/2 Cable Bases)	20 Chairs Maximum (10 Legs/2 Cable Bases)	20 Chairs Maximum (10 Legs/2 Cable Bases)	20 Chairs Maximum (10 Legs/2 Cable Bases)	20 Chairs Maximum (10 Legs/2 Cable Bases)	20 Chairs Maximum (10 Legs/2 Cable Bases)	20 Chairs Maximum (10 Legs/2 Cable Bases)

Note Recommended seating capacity based upon a width of 27" per chair.

Product Details – Planes Interior Leg Conference Tables

Pebble (Three-Piece Top)

Without Cable Base

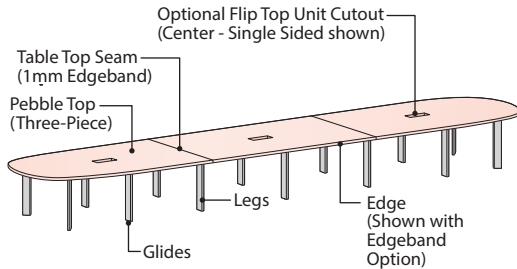

With Cable Base

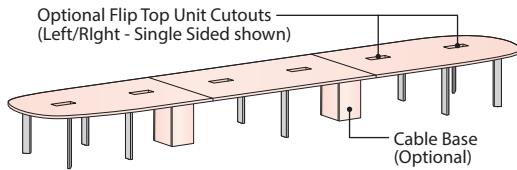

Edge Options for Laminate Tops

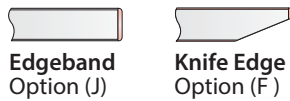

Edge Options for Wood Tops



Component Materials/Finishes

COMPONENT NAME	MATERIALS/ FINISHES
Pebble Top 3-Piece top with 1mm edgeband seams	Laminate Top – Specify separate finish colors for top and edge trim • Edge Options: (J) Edgeband, (F) Knife
	Wood Top – Specify a single finish color for the top and edge trim • Edge Options: (K) Edgeband, (U) Knife
Interior Legs	Painted Metal – Specified Trim Color
Glides	Standard in Black
Cable Base (Optional)	Panels Laminate Panels – Specified surface and edge trim colors Wood Panels – Specified top and edge trim wood finish color
	Frame Painted Metal – Standard in Black

Flip Top Unit Cutout Options

Center Cutout Option

- Includes 3 Flip Top Unit cutouts
(1 Cutout centered on each top piece)

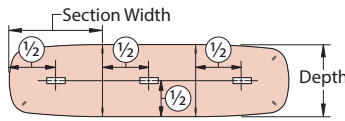

Left/Right Cutout Option

- Includes 6 Flip Top Unit cutouts
(2 Cutouts on each top piece)

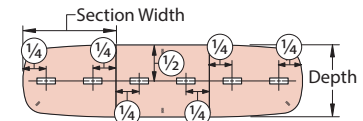

Cutout Option (F or V)

- For use with Single Sided/
4 Port Flip Top Unit

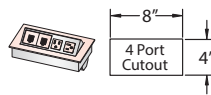

Cutout Option (J or K)

- For use with Single Sided/
6 Ports Flip Top Unit

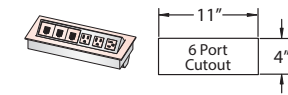

Cutout Option (M or P)

- For use with Double Sided/
8 Ports Flip Top Unit

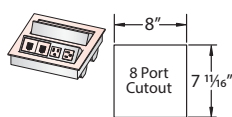

Cutout Option (Q or T)

- For use with Double Sided/
12 Ports Flip Top Unit

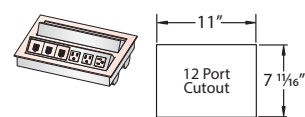

Note Flip Top Units are separately specified.

Cable Base Options

- Tables may be specified with or without Cable Bases
 - (Option N) No Cable Base.
 - (Option C) Includes (2) 14" x 14" Cable Bases

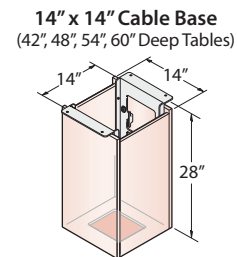
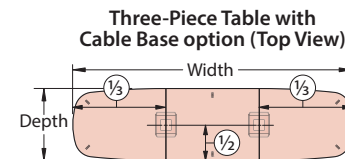

Cable Bases are centered on the seams between top pieces.

Product Details – Planes Interior Leg Conference Tables

Pebble (Three-Piece Top)

Dimensions – 186"-198" Wide
Tables Without Cable Base
Includes (8) Legs

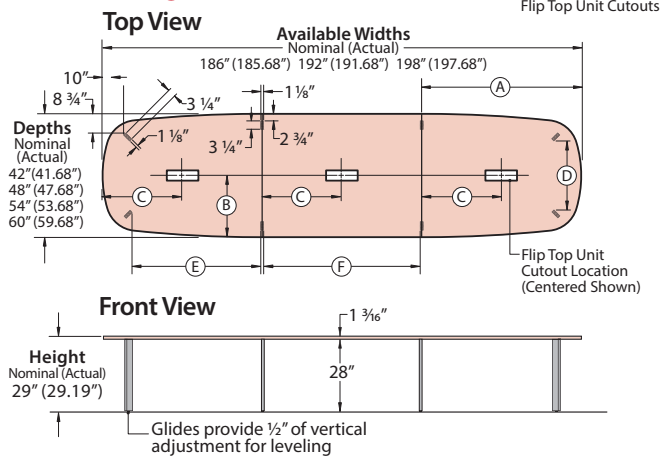

Dimensions 204"-216" Wide
Tables Without Cable Base
Includes (10) Legs

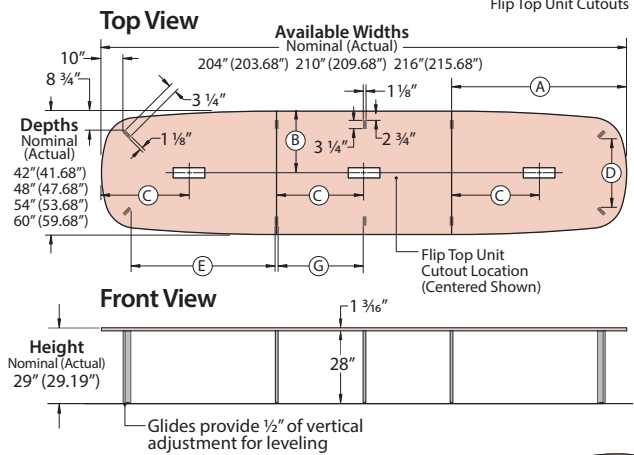

Dimensions – 222"-270" Wide
Tables Without Cable Base
Includes (14) Legs

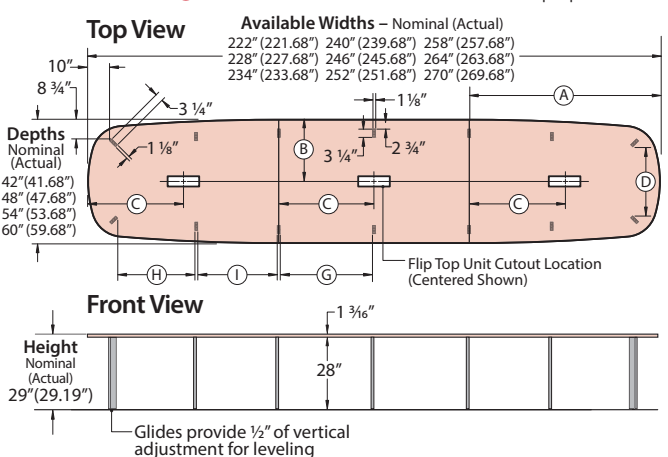

Note Tables are available with the following Flip Top Unit cutout options:
 • None – No Flip Top Unit Cutouts
 • Centered – (1) Cutout centered on each top (shown above)
 • Left/Right – (2) Cutouts on each top
 (See following page for dimensions)

Dimensions

TABLETOP				KNEESPACE (Nominal)								# of Legs	
Depth Nominal (Actual)	Width Nominal (Actual)	# of Top Pieces	A	B	C	D	E	F	G	H	I		
42" (41.68")	186"(185.68")	3	62"	21"	31"	22"	50"	60"	N/A	N/A	N/A	8	
	192"(191.68")	3	64"	21"	32"	22"	52"	62"	N/A	N/A	N/A	8	
	198"(197.68")	3	66"	21"	33"	22"	54"	64"	N/A	N/A	N/A	8	
	204"(203.68")	3	68"	21"	34"	22"	56"	N/A	32"	N/A	N/A	10	
	210"(209.68")	3	70"	21"	35"	22"	58"	N/A	33"	N/A	N/A	10	
	216"(215.68")	3	72"	21"	36"	22"	60"	N/A	34"	N/A	N/A	10	
	222"(221.68")	3	74"	21"	37"	22"	N/A	N/A	35"	31"	30"	14	
	228"(227.68")	3	76"	21"	38"	22"	N/A	N/A	36"	32"	31"	14	
	234"(233.68")	3	78"	21"	39"	22"	N/A	N/A	37"	33"	32"	14	
	240"(239.68")	3	80"	21"	40"	22"	N/A	N/A	38"	34"	33"	14	
48" (47.68")	246"(245.68")	3	82"	21"	41"	22"	N/A	N/A	39"	35"	34"	14	
	252"(251.68")	3	84"	21"	42"	22"	N/A	N/A	40"	36"	35"	14	
	258"(257.68")	3	86"	21"	43"	22"	N/A	N/A	41"	37"	36"	14	
	264"(263.68")	3	88"	21"	44"	22"	N/A	N/A	42"	38"	37"	14	
	270"(269.68")	3	90"	21"	45"	22"	N/A	N/A	43"	39"	38"	14	
	54" (53.68")	186"(185.68")	3	62"	27"	31"	32"	50"	60"	N/A	N/A	N/A	8
		192"(191.68")	3	64"	27"	32"	32"	52"	62"	N/A	N/A	N/A	8
		198"(197.68")	3	66"	27"	33"	32"	54"	64"	N/A	N/A	N/A	8
		204"(203.68")	3	68"	27"	34"	32"	56"	N/A	32"	N/A	N/A	10
		210"(209.68")	3	70"	27"	35"	32"	58"	N/A	33"	N/A	N/A	10
216"(215.68")		3	72"	27"	36"	32"	60"	N/A	34"	N/A	N/A	10	
222"(221.68")		3	74"	27"	37"	32"	N/A	N/A	35"	31"	30"	14	
228"(227.68")		3	76"	27"	38"	32"	N/A	N/A	36"	32"	31"	14	
234"(233.68")		3	78"	27"	39"	32"	N/A	N/A	37"	33"	32"	14	
240"(239.68")		3	80"	27"	40"	32"	N/A	N/A	38"	34"	33"	14	
60" (59.68")	246"(245.68")	3	82"	27"	41"	32"	N/A	N/A	39"	35"	34"	14	
	252"(251.68")	3	84"	27"	42"	32"	N/A	N/A	40"	36"	35"	14	
	258"(257.68")	3	86"	27"	43"	32"	N/A	N/A	41"	37"	36"	14	
	264"(263.68")	3	88"	27"	44"	32"	N/A	N/A	42"	38"	37"	14	
	270"(269.68")	3	90"	27"	45"	32"	N/A	N/A	43"	39"	38"	14	
	60" (59.68")	186"(185.68")	3	62"	30"	31"	36"	50"	60"	N/A	N/A	N/A	8
		192"(191.68")	3	64"	30"	32"	36"	52"	62"	N/A	N/A	N/A	8
		198"(197.68")	3	66"	30"	33"	36"	54"	64"	N/A	N/A	N/A	8
		204"(203.68")	3	68"	30"	34"	36"	56"	N/A	32"	N/A	N/A	10
		210"(209.68")	3	70"	30"	35"	36"	58"	N/A	33"	N/A	N/A	10
216"(215.68")		3	72"	30"	36"	36"	60"	N/A	34"	N/A	N/A	10	
222"(221.68")		3	74"	30"	37"	36"	N/A	N/A	35"	31"	30"	14	
228"(227.68")		3	76"	30"	38"	36"	N/A	N/A	36"	32"	31"	14	
234"(233.68")		3	78"	30"	39"	36"	N/A	N/A	37"	33"	32"	14	
240"(239.68")		3	80"	30"	40"	36"	N/A	N/A	38"	34"	33"	14	
60" (59.68")	246"(245.68")	3	82"	30"	41"	36"	N/A	N/A	39"	35"	34"	14	
	252"(251.68")	3	84"	30"	42"	36"	N/A	N/A	40"	36"	35"	14	
	258"(257.68")	3	86"	30"	43"	36"	N/A	N/A	41"	37"	36"	14	
	264"(263.68")	3	88"	30"	44"	36"	N/A	N/A	42"	38"	37"	14	
	270"(269.68")	3	90"	30"	45"	36"	N/A	N/A	43"	39"	38"	14	

Product Details – Planes Interior Leg Conference Tables

Pebble (Three-Piece Top)

Dimensions – 186"-216" Wide
Tables Without Cable Base
Includes (6) Legs

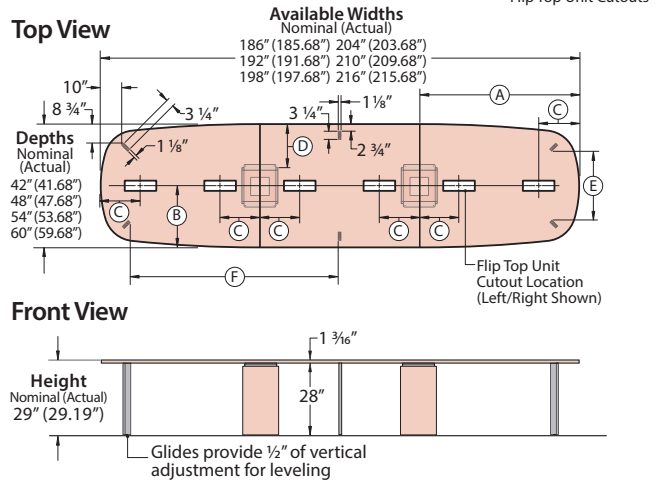

Dimensions – 222"-270" Wide
Table Without Cable Base
Includes (10) Legs

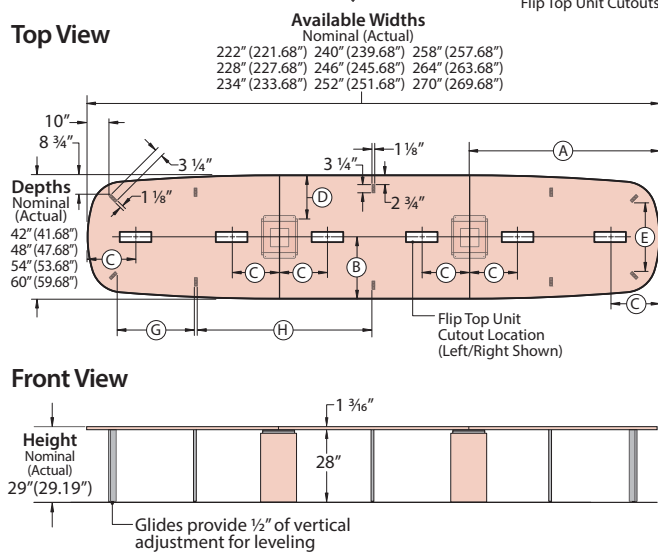

Note Tables are available with the following Flip Top Unit cutouts options:

- None – No Flip Top Unit Cutouts
- Centered – (1) Cutout centered on each top (see previous page for dimensions)
- Left/Right – (2) Cutouts on each top (shown above)

Dimensions

TABLETOP				KNEESPACE (Nominal)								
Depth Nominal (Actual)	Width Nominal (Actual)	# of Top Pieces	A	B	C	D	E	F	G	H	# of Legs with (2) Cable Bases	
42" (41.68")	186"(185.68")	3	62"	21"	31"	14"	22"	81"	N/A	N/A	6	
	192"(191.68")	3	64"	21"	32"	22"	22"	84"	N/A	N/A	6	
	198"(197.68")	3	66"	21"	33"	22"	22"	87"	N/A	N/A	6	
	204"(203.68")	3	68"	21"	34"	22"	22"	N/A	N/A	61"	6	
	210"(209.68")	3	70"	21"	35"	22"	22"	N/A	N/A	63"	6	
	216"(215.68")	3	72"	21"	36"	22"	22"	N/A	N/A	65"	6	
	222"(221.68")	3	74"	21"	37"	22"	22"	N/A	N/A	31"	67"	10
	228"(227.68")	3	76"	21"	38"	22"	22"	N/A	N/A	32"	69"	10
	234"(233.68")	3	78"	21"	39"	22"	22"	N/A	N/A	33"	71"	10
	240"(239.68")	3	80"	21"	40"	22"	22"	N/A	N/A	34"	73"	10
	246"(245.68")	3	82"	21"	41"	22"	22"	N/A	N/A	35"	75"	10
	252"(251.68")	3	84"	21"	42"	22"	22"	N/A	N/A	36"	77"	10
48" (47.68")	186"(185.68")	3	62"	24"	31"	27"	27"	81"	N/A	N/A	6	
	192"(191.68")	3	64"	24"	32"	27"	27"	84"	N/A	N/A	6	
	198"(197.68")	3	66"	24"	33"	27"	27"	87"	N/A	N/A	6	
	204"(203.68")	3	68"	24"	34"	27"	27"	N/A	N/A	61"	6	
	210"(209.68")	3	70"	24"	35"	27"	27"	N/A	N/A	63"	6	
	216"(215.68")	3	72"	24"	36"	27"	27"	N/A	N/A	65"	6	
	222"(221.68")	3	74"	24"	37"	27"	27"	N/A	N/A	31"	67"	10
	228"(227.68")	3	76"	24"	38"	27"	27"	N/A	N/A	32"	69"	10
	234"(233.68")	3	78"	24"	39"	27"	27"	N/A	N/A	33"	71"	10
	240"(239.68")	3	80"	24"	40"	27"	27"	N/A	N/A	34"	73"	10
	246"(245.68")	3	82"	24"	41"	27"	27"	N/A	N/A	35"	75"	10
	252"(251.68")	3	84"	24"	42"	27"	27"	N/A	N/A	36"	77"	10
54" (53.68")	186"(185.68")	3	62"	27"	31"	32"	32"	81"	N/A	N/A	6	
	192"(191.68")	3	64"	27"	32"	32"	32"	84"	N/A	N/A	6	
	198"(197.68")	3	66"	27"	33"	32"	32"	87"	N/A	N/A	6	
	204"(203.68")	3	68"	27"	34"	32"	32"	N/A	N/A	61"	6	
	210"(209.68")	3	70"	27"	35"	32"	32"	N/A	N/A	63"	6	
	216"(215.68")	3	72"	27"	36"	32"	32"	N/A	N/A	65"	6	
	222"(221.68")	3	74"	27"	37"	32"	32"	N/A	N/A	31"	67"	10
	228"(227.68")	3	76"	27"	38"	32"	32"	N/A	N/A	32"	69"	10
	234"(233.68")	3	78"	27"	39"	32"	32"	N/A	N/A	33"	71"	10
	240"(239.68")	3	80"	27"	40"	32"	32"	N/A	N/A	34"	73"	10
	246"(245.68")	3	82"	27"	41"	32"	32"	N/A	N/A	35"	75"	10
	252"(251.68")	3	84"	27"	42"	32"	32"	N/A	N/A	36"	77"	10
60" (59.68")	186"(185.68")	3	62"	30"	31"	36"	36"	81"	N/A	N/A	6	
	192"(191.68")	3	64"	30"	32"	36"	36"	84"	N/A	N/A	6	
	198"(197.68")	3	66"	30"	33"	36"	36"	87"	N/A	N/A	6	
	204"(203.68")	3	68"	30"	34"	36"	36"	N/A	N/A	61"	6	
	210"(209.68")	3	70"	30"	35"	36"	36"	N/A	N/A	63"	6	
	216"(215.68")	3	72"	30"	36"	36"	36"	N/A	N/A	65"	6	
	222"(221.68")	3	74"	30"	37"	36"	36"	N/A	N/A	31"	67"	10
	228"(227.68")	3	76"	30"	38"	36"	36"	N/A	N/A	32"	69"	10
	234"(233.68")	3	78"	30"	39"	36"	36"	N/A	N/A	33"	71"	10
	240"(239.68")	3	80"	30"	40"	36"	36"	N/A	N/A	34"	73"	10
	246"(245.68")	3	82"	30"	41"	36"	36"	N/A	N/A	35"	75"	10
	252"(251.68")	3	84"	30"	42"	36"	36"	N/A	N/A	36"	77"	10

Product Details – Planes Interior Leg Conference Tables

Pebble (Three-Piece Top)

Table Sizes and Seating Capacities – Without Cable Bases

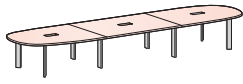

• 186", 192" and 198" Wide Three-Piece Top Tables specified without a Cable Base are standard with 8 Legs.

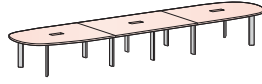

• 204", 210" and 216" Wide Three-Piece Top Tables specified without a Cable Base are standard with 10 Legs.

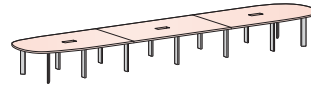

• 222", 228", 234", 240", 246", 252", 258", 264" and 270" Wide Three-Piece Top Tables specified without a Cable Base are standard with 14 Legs.

		WIDTHS							
		186" Wide	192" Wide	198" Wide	204" Wide	210" Wide	216" Wide	222" Wide	228" Wide
DEPTHS	42" Deep								
	48" Deep								
	54" Deep								
	60" Deep								

		WIDTHS						
		234" Wide	240" Wide	246" Wide	252" Wide	258" Wide	264" Wide	270" Wide
DEPTHS	42" Deep							
	48" Deep							
	54" Deep							
	60" Deep							

Note Recommended seating capacity based upon a width of 27" per chair.

Product Details – Planes Interior Leg Conference Tables

Pebble (Three-Piece Top)

Table Sizes and Seating Capacities – Without Cable Bases

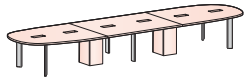

186", 192", 198", 204", 210" and 216" Wide Three-Piece Top Tables specified with Cable Bases are standard with 6 Legs and 2 Cable Bases.

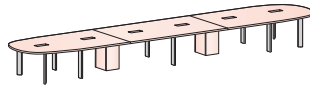

222", 228", 234", 240", 246", 252", 258", 264" and 270" Wide Three-Piece Top Tables specified with a Cable Base are standard with 10 Legs and 2 Cable Bases.

		WIDTHS							
		186" Wide	192" Wide	198" Wide	204" Wide	210" Wide	216" Wide	222" Wide	228" Wide
DEPTHS	42" Deep								
	48" Deep								
	54" Deep								
	60" Deep								

		WIDTHS						
		234" Wide	240" Wide	246" Wide	252" Wide	258" Wide	264" Wide	270" Wide
DEPTHS	42" Deep							
	48" Deep							
	54" Deep							
	60" Deep							

Note Recommended seating capacity based upon a width of 27" per chair.

Product Details – Planes Interior Leg Conference Tables

Hexagon (Three-Piece Top)

Without Cable Base

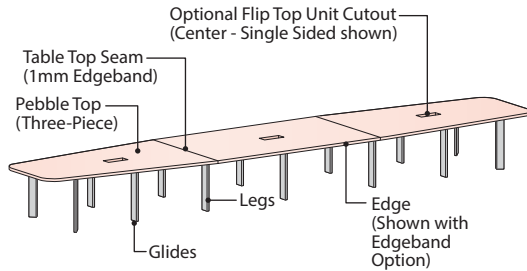

With Cable Base

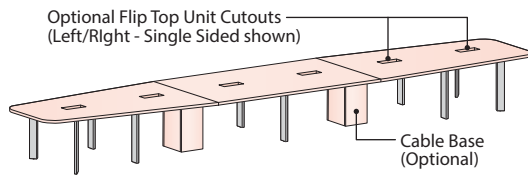

Edge Options for Laminate Tops

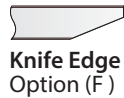
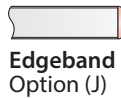

Edge Options for Wood Tops

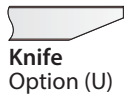
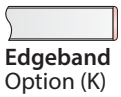

Component Materials/Finishes

COMPONENT NAME	MATERIALS/ FINISHES
Pebble Top 3-Piece top with 1mm edgeband seams	Laminate Top – Specify separate finish colors for top and edge trim • Edge Options: (J) Edgeband, (F) Knife
Interior Legs	Painted Metal – Specified Trim Color
Glides	Standard in Black
Cable Base (Optional)	Panels Laminate Panels – Specified surface and edge trim colors Wood Panels – Specified top and edge trim wood finish color
	Frame Painted Metal – Standard in Black

Flip Top Unit Cutout Options

Center Cutout Option

- Includes 3 Flip Top Unit cutouts (1 Cutout centered on each top piece)

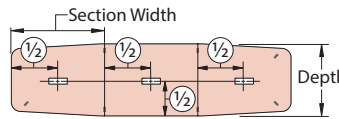

Left/Right Cutout Option

- Includes 6 Flip Top Unit cutouts (2 Cutouts on each top piece)

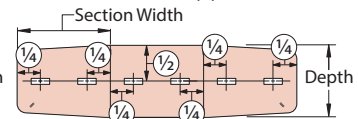

Cutout Option (F or V)

- For use with Single Sided/ 4 Port Flip Top Unit

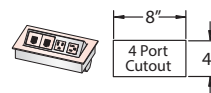

Cutout Option (J or K)

- For use with Single Sided/ 6 Ports Flip Top Unit

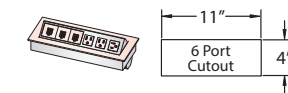

Cutout Option (M or P)

- For use with Double Sided/ 8 Ports Flip Top Unit

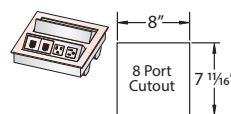

Cutout Option (Q or T)

- For use with Double Sided/ 12 Ports Flip Top Unit

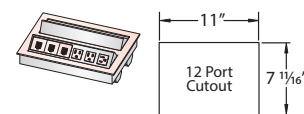

Note Flip Top Units are separately specified.

Cable Base Options

- Tables may be specified with or without Cable Bases
 - (Option N) No Cable Base.
 - (Option C) Includes (2) 14" x 14" Cable Bases

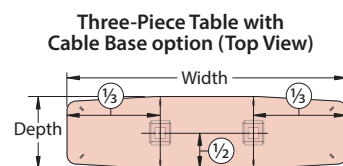

Cable Bases are centered on the seams between top pieces.

14" x 14" Cable Base (42", 48", 54", 60" Deep Tables)

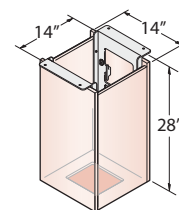

Product Details – Planes Interior Leg Conference Tables

Hexagon (Three-Piece Top)

Dimensions – 186"-198" Wide
Tables Without Cable Base
Includes (8) Legs

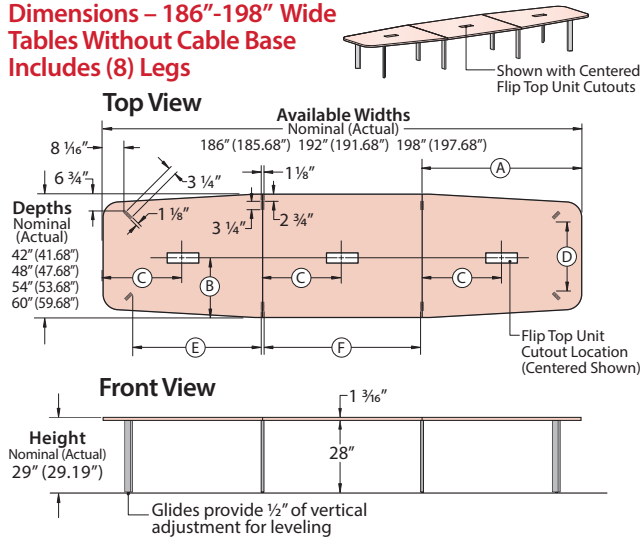

Dimensions – 204"-216" Wide
Tables Without Cable Base
Includes (10) Legs

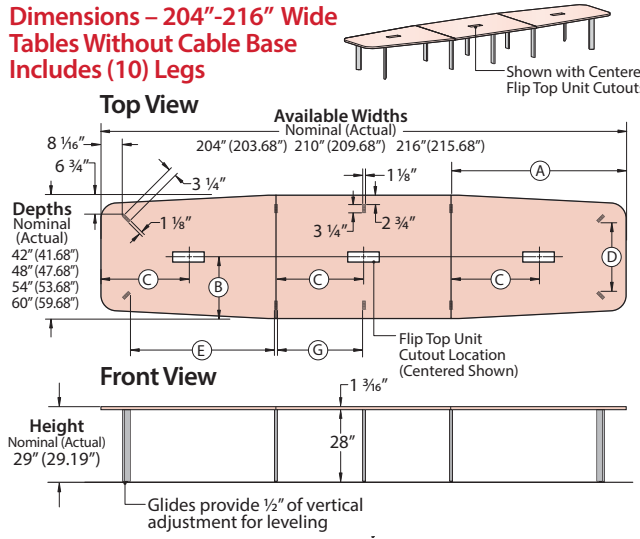

Dimensions – 222"-270" Wide
Tables Without Cable Base
Includes (14) Legs

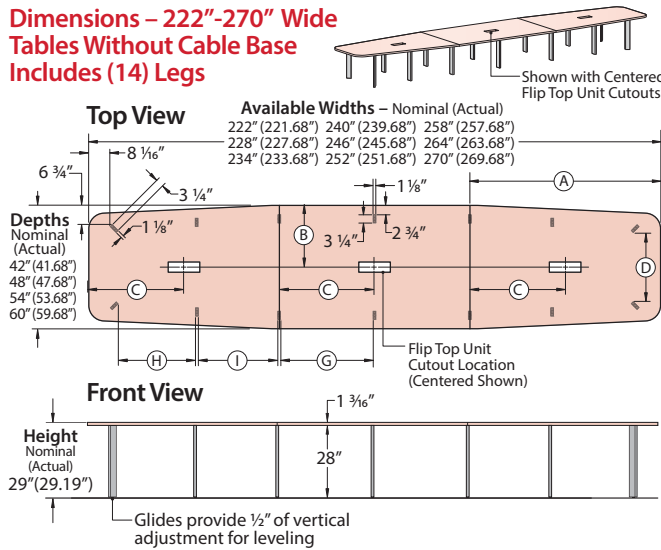

Note Tables are available with the following Flip Top Unit cutouts options:

- None – No Flip Top Unit Cutouts
- Centered – (1) Cutout centered on each top (shown above)
- Left/Right – (2) Cutouts on each top (See following page for dimensions)

Dimensions

Depth Nominal (Actual)	TABLETOP			KNEESPACE (Nominal)								# of Legs	
	Width Nominal (Actual)	# of Top Pieces		A	B	C	D	E	F	G	H		I
42" (41.68")	186"(185.68")	3		62"	21"	31"	22"	50"	60"	N/A	N/A	N/A	8
	192"(191.68")	3		64"	21"	32"	22"	52"	62"	N/A	N/A	N/A	8
	198"(197.68")	3		66"	21"	33"	22"	54"	64"	N/A	N/A	N/A	8
	204"(203.68")	3		68"	21"	34"	22"	56"	N/A	32"	N/A	N/A	10
	210"(209.68")	3		70"	21"	35"	22"	58"	N/A	33"	N/A	N/A	10
	216"(215.68")	3		72"	21"	36"	22"	60"	N/A	34"	N/A	N/A	10
	222"(221.68")	3		74"	21"	37"	22"	N/A	N/A	35"	30"	31"	14
	228"(227.68")	3		76"	21"	38"	22"	N/A	N/A	36"	31"	32"	14
	234"(233.68")	3		78"	21"	39"	22"	N/A	N/A	37"	32"	33"	14
	240"(239.68")	3		80"	21"	40"	22"	N/A	N/A	38"	33"	34"	14
	246"(245.68")	3		82"	21"	41"	22"	N/A	N/A	39"	34"	35"	14
	252"(251.68")	3		84"	21"	42"	22"	N/A	N/A	40"	35"	36"	14
	258"(257.68")	3		86"	21"	43"	22"	N/A	N/A	41"	36"	37"	14
	264"(263.68")	3		88"	21"	44"	22"	N/A	N/A	42"	37"	38"	14
270"(269.68")	3		90"	21"	45"	22"	N/A	N/A	43"	38"	39"	14	
48" (47.68")	186"(185.68")	3		62"	24"	31"	28"	50"	60"	N/A	N/A	N/A	8
	192"(191.68")	3		64"	24"	32"	28"	52"	62"	N/A	N/A	N/A	8
	198"(197.68")	3		66"	24"	33"	28"	54"	64"	N/A	N/A	N/A	8
	204"(203.68")	3		68"	24"	34"	28"	56"	N/A	32"	N/A	N/A	10
	210"(209.68")	3		70"	24"	35"	28"	58"	N/A	33"	N/A	N/A	10
	216"(215.68")	3		72"	24"	36"	28"	60"	N/A	34"	N/A	N/A	10
	222"(221.68")	3		74"	24"	37"	28"	N/A	N/A	35"	30"	31"	14
	228"(227.68")	3		76"	24"	38"	28"	N/A	N/A	36"	31"	32"	14
	234"(233.68")	3		78"	24"	39"	28"	N/A	N/A	37"	32"	33"	14
	240"(239.68")	3		80"	24"	40"	28"	N/A	N/A	38"	33"	34"	14
	246"(245.68")	3		82"	24"	41"	28"	N/A	N/A	39"	34"	35"	14
	252"(251.68")	3		84"	24"	42"	28"	N/A	N/A	40"	35"	36"	14
	258"(257.68")	3		86"	24"	43"	28"	N/A	N/A	41"	36"	37"	14
	264"(263.68")	3		88"	24"	44"	28"	N/A	N/A	42"	37"	38"	14
270"(269.68")	3		90"	24"	45"	28"	N/A	N/A	43"	38"	39"	14	
54" (53.68")	186"(185.68")	3		62"	27"	31"	34"	50"	60"	N/A	N/A	N/A	8
	192"(191.68")	3		64"	27"	32"	34"	52"	62"	N/A	N/A	N/A	8
	198"(197.68")	3		66"	27"	33"	34"	54"	64"	N/A	N/A	N/A	8
	204"(203.68")	3		68"	27"	34"	34"	56"	N/A	32"	N/A	N/A	10
	210"(209.68")	3		70"	27"	35"	34"	58"	N/A	33"	N/A	N/A	10
	216"(215.68")	3		72"	27"	36"	34"	60"	N/A	34"	N/A	N/A	10
	222"(221.68")	3		74"	27"	37"	34"	N/A	N/A	35"	30"	31"	14
	228"(227.68")	3		76"	27"	38"	34"	N/A	N/A	36"	31"	32"	14
	234"(233.68")	3		78"	27"	39"	34"	N/A	N/A	37"	32"	33"	14
	240"(239.68")	3		80"	27"	40"	34"	N/A	N/A	38"	33"	34"	14
	246"(245.68")	3		82"	27"	41"	34"	N/A	N/A	39"	34"	35"	14
	252"(251.68")	3		84"	27"	42"	34"	N/A	N/A	40"	35"	36"	14
	258"(257.68")	3		86"	27"	43"	34"	N/A	N/A	41"	36"	37"	14
	264"(263.68")	3		88"	27"	44"	34"	N/A	N/A	42"	37"	38"	14
270"(269.68")	3		90"	27"	45"	34"	N/A	N/A	43"	38"	39"	14	
60" (59.68")	186"(185.68")	3		62"	30"	31"	40"	50"	60"	N/A	N/A	N/A	8
	192"(191.68")	3		64"	30"	32"	40"	52"	62"	N/A	N/A	N/A	8
	198"(197.68")	3		66"	30"	33"	40"	54"	64"	N/A	N/A	N/A	8
	204"(203.68")	3		68"	30"	34"	40"	56"	N/A	32"	N/A	N/A	10
	210"(209.68")	3		70"	30"	35"	40"	58"	N/A	33"	N/A	N/A	10
	216"(215.68")	3		72"	30"	36"	40"	60"	N/A	34"	N/A	N/A	10
	222"(221.68")	3		74"	30"	37"	40"	N/A	N/A	35"	30"	31"	14
	228"(227.68")	3		76"	30"	38"	40"	N/A	N/A	36"	31"	32"	14
	234"(233.68")	3		78"	30"	39"	40"	N/A	N/A	37"	32"	33"	14
	240"(239.68")	3		80"	30"	40"	40"	N/A	N/A	38"	33"	34"	14
	246"(245.68")	3		82"	30"	41"	40"	N/A	N/A	39"	34"	35"	14
	252"(251.68")	3		84"	30"	42"	40"	N/A	N/A	40"	35"	36"	14
	258"(257.68")	3		86"	30"	43"	40"	N/A	N/A	41"	36"	37"	14
	264"(263.68")	3		88"	30"	44"	40"	N/A	N/A	42"	37"	38"	14
270"(269.68")	3		90"	30"	45"	40"	N/A	N/A	43"	38"	39"	14	

Product Details – Planes Interior Leg Conference Tables

Hexagon (Three-Piece Top)

Dimensions – 186"-216" Wide
Tables Without Cable Base
Includes (6) Legs

Top View

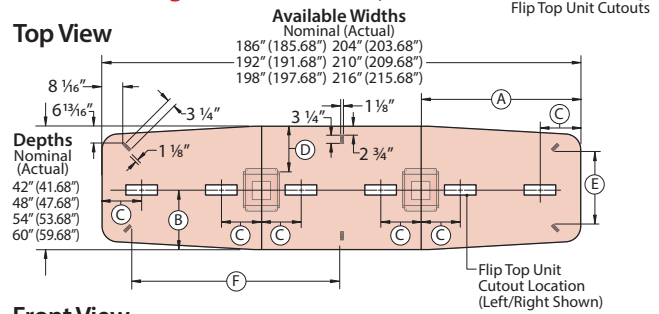

Front View

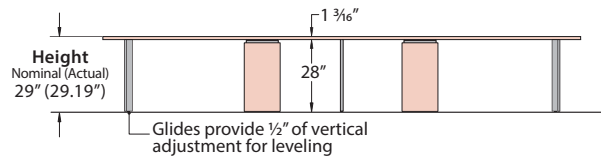

Dimensions – 222"-270" Wide
Tables Without Cable Base
Includes (10) Legs

Top View

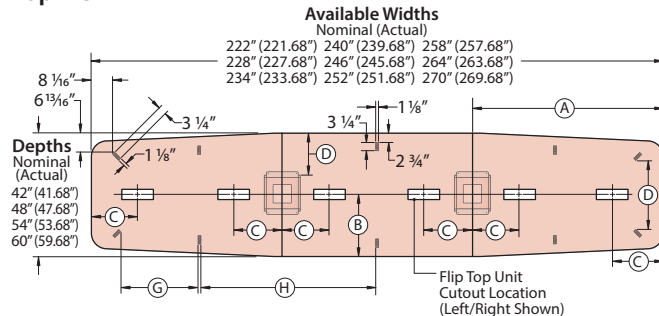

Front View

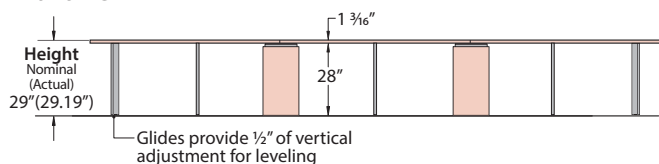

- Note** Tables are available with the following Flip Top Unit cutout options:
- None – No Flip Top Unit Cutouts
 - Centered – (1) Cutout centered on each top (see previous page for dimensions)
 - Left/Right – (2) Cutouts on each top (shown above)

Dimensions

Depth Nominal (Actual)	TABLETOP			KNEESPACE (Nominal)								# of Legs with (2) Cable Bases	
	Width Nominal (Actual)	# of Top Pieces		A	B	C	D	E	F	G	H		
42" (41.68")	186"(185.68")	3		62"	21"	31"	14"	22"	81"	N/A	N/A	6	
	192"(191.68")	3		64"	21"	32"	14"	22"	84"	N/A	N/A	6	
	198"(197.68")	3		66"	21"	33"	14"	22"	87"	N/A	N/A	6	
	204"(203.68")	3		68"	21"	34"	14"	22"	N/A	N/A	62"	6	
	210"(209.68")	3		70"	21"	35"	14"	22"	N/A	N/A	63"	6	
	216"(215.68")	3		72"	21"	36"	14"	22"	N/A	N/A	64"	6	
	222"(221.68")	3		74"	21"	37"	14"	22"	N/A	N/A	30"	65"	10
	228"(227.68")	3		76"	21"	38"	14"	22"	N/A	N/A	31"	66"	10
	234"(233.68")	3		78"	21"	39"	14"	22"	N/A	N/A	32"	67"	10
	240"(239.68")	3		80"	21"	40"	14"	22"	N/A	N/A	33"	68"	10
	246"(245.68")	3		82"	21"	41"	14"	22"	N/A	N/A	34"	69"	10
	252"(251.68")	3		84"	21"	42"	14"	22"	N/A	N/A	35"	70"	10
	258"(257.68")	3		86"	21"	43"	14"	22"	N/A	N/A	36"	71"	10
	264"(263.68")	3		88"	21"	44"	14"	22"	N/A	N/A	37"	72"	10
270"(269.68")	3		90"	21"	45"	14"	22"	N/A	N/A	38"	73"	10	
48" (47.68")	186"(185.68")	3		62"	24"	31"	17"	28"	81"	N/A	N/A	6	
	192"(191.68")	3		64"	24"	32"	17"	28"	84"	N/A	N/A	6	
	198"(197.68")	3		66"	24"	33"	17"	28"	87"	N/A	N/A	6	
	204"(203.68")	3		68"	24"	34"	17"	28"	N/A	N/A	62"	6	
	210"(209.68")	3		70"	24"	35"	17"	28"	N/A	N/A	63"	6	
	216"(215.68")	3		72"	24"	36"	17"	28"	N/A	N/A	64"	6	
	222"(221.68")	3		74"	24"	37"	17"	28"	N/A	N/A	30"	65"	10
	228"(227.68")	3		76"	24"	38"	17"	28"	N/A	N/A	31"	66"	10
	234"(233.68")	3		78"	24"	39"	17"	28"	N/A	N/A	32"	67"	10
	240"(239.68")	3		80"	24"	40"	17"	28"	N/A	N/A	33"	68"	10
	246"(245.68")	3		82"	24"	41"	17"	28"	N/A	N/A	34"	69"	10
	252"(251.68")	3		84"	24"	42"	17"	28"	N/A	N/A	35"	70"	10
	258"(257.68")	3		86"	24"	43"	17"	28"	N/A	N/A	36"	71"	10
	264"(263.68")	3		88"	24"	44"	17"	28"	N/A	N/A	37"	72"	10
270"(269.68")	3		90"	24"	45"	17"	28"	N/A	N/A	38"	73"	10	
54" (53.68")	186"(185.68")	3		62"	27"	31"	20"	34"	81"	N/A	N/A	6	
	192"(191.68")	3		64"	27"	32"	20"	34"	84"	N/A	N/A	6	
	198"(197.68")	3		66"	27"	33"	20"	34"	87"	N/A	N/A	6	
	204"(203.68")	3		68"	27"	34"	20"	34"	N/A	N/A	62"	6	
	210"(209.68")	3		70"	27"	35"	20"	34"	N/A	N/A	63"	6	
	216"(215.68")	3		72"	27"	36"	20"	34"	N/A	N/A	64"	6	
	222"(221.68")	3		74"	27"	37"	20"	34"	N/A	N/A	30"	65"	10
	228"(227.68")	3		76"	27"	38"	20"	34"	N/A	N/A	31"	66"	10
	234"(233.68")	3		78"	27"	39"	20"	34"	N/A	N/A	32"	67"	10
	240"(239.68")	3		80"	27"	40"	20"	34"	N/A	N/A	33"	68"	10
	246"(245.68")	3		82"	27"	41"	20"	34"	N/A	N/A	34"	69"	10
	252"(251.68")	3		84"	27"	42"	20"	34"	N/A	N/A	35"	70"	10
	258"(257.68")	3		86"	27"	43"	20"	34"	N/A	N/A	36"	71"	10
	264"(263.68")	3		88"	27"	44"	20"	34"	N/A	N/A	37"	72"	10
270"(269.68")	3		90"	27"	45"	20"	34"	N/A	N/A	38"	73"	10	
60" (59.68")	186"(185.68")	3		62"	30"	31"	23"	40"	81"	N/A	N/A	6	
	192"(191.68")	3		64"	30"	32"	23"	40"	84"	N/A	N/A	6	
	198"(197.68")	3		66"	30"	33"	23"	40"	87"	N/A	N/A	6	
	204"(203.68")	3		68"	30"	34"	23"	40"	N/A	N/A	62"	6	
	210"(209.68")	3		70"	30"	35"	23"	40"	N/A	N/A	63"	6	
	216"(215.68")	3		72"	30"	36"	23"	40"	N/A	N/A	64"	6	
	222"(221.68")	3		74"	30"	37"	23"	40"	N/A	N/A	30"	65"	10
	228"(227.68")	3		76"	30"	38"	23"	40"	N/A	N/A	31"	66"	10
	234"(233.68")	3		78"	30"	39"	23"	40"	N/A	N/A	32"	67"	10
	240"(239.68")	3		80"	30"	40"	23"	40"	N/A	N/A	33"	68"	10
	246"(245.68")	3		82"	30"	41"	23"	40"	N/A	N/A	34"	69"	10
	252"(251.68")	3		84"	30"	42"	23"	40"	N/A	N/A	35"	70"	10
	258"(257.68")	3		86"	30"	43"	23"	40"	N/A	N/A	36"	71"	10
	264"(263.68")	3		88"	30"	44"	23"	40"	N/A	N/A	37"	72"	10
270"(269.68")	3		90"	30"	45"	23"	40"	N/A	N/A	38"	73"	10	

Product Details – Planes Interior Leg Conference Tables

Hexagon (Three-Piece Top)

Table Sizes and Seating Capacities – Without Cable Bases

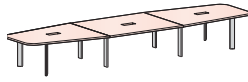

186", 192" and 198" Wide Three-Piece Top Tables specified without a Cable Base are standard with 8 Legs.

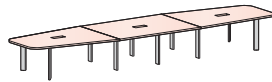

204", 210" and 216" Wide Three-Piece Top Tables specified without a Cable Base are standard with 10 Legs.

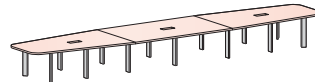

222", 228", 234", 240", 246", 252", 258", 264" and 270" Wide Three-Piece Top Tables specified without a Cable Base are standard with 14 Legs.

		WIDTHS							
		186" Wide	192" Wide	198" Wide	204" Wide	210" Wide	216" Wide	222" Wide	228" Wide
DEPTHS	42" Deep								
	48" Deep								
	54" Deep								
	60" Deep								

		WIDTHS						
		234" Wide	240" Wide	246" Wide	252" Wide	258" Wide	264" Wide	270" Wide
DEPTHS	42" Deep							
	48" Deep							
	54" Deep							
	60" Deep							

Note Recommended seating capacity based upon a width of 27" per chair.

Product Details – Planes Interior Leg Conference Tables

Hexagon (Three-Piece Top)

Table Sizes and Seating Capacities – Without Cable Bases

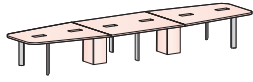

186", 192", 198", 204", 210" and 216" Wide Three-Piece Top Tables specified with Cable Bases are standard with 6 Legs and 2 Cable Bases.

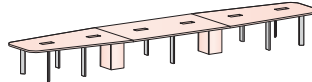

222", 228", 234", 240", 246", 252", 258", 264" and 270" Wide Three-Piece Top Tables specified with a Cable Base are standard with 10 Legs and 2 Cable Bases.

		WIDTHS							
		186" Wide	192" Wide	198" Wide	204" Wide	210" Wide	216" Wide	222" Wide	228" Wide
DEPTHS	42" Deep								
	48" Deep								
	54" Deep								
	60" Deep								

		WIDTHS						
		234" Wide	240" Wide	246" Wide	252" Wide	258" Wide	264" Wide	270" Wide
DEPTHS	42" Deep							
	48" Deep							
	54" Deep							
	60" Deep							

Note Recommended seating capacity based upon a width of 27" per chair.

Product Details – Planes Perimeter Leg Conference Tables

Overview

Conference tables with the Perimeter Leg can be specified in rectangle and square in a variety of sizes to accommodate any conference room. The rectilinear design of the Perimeter Leg, along with the sleek profile of the 2" built up edge, give the table a contemporary aesthetic.

Table Components

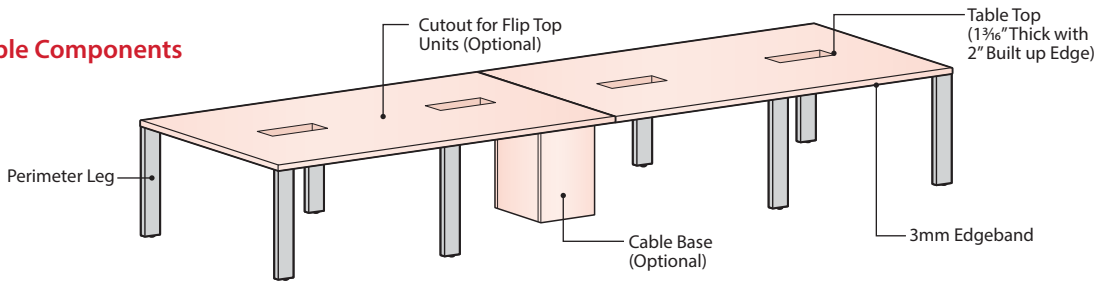

Features

- The rectangular shaped perimeter legs align with the edge of the table top at the perimeter.
- Perimeter Legs are 1 3/8" x 4" and are painted aluminum.
- Glides have a 1/2" adjustment range and are standard in black finish.
- The tops are available in wood or laminate finishes.
- Standard table height is 30" high with 28" knee clearance.
- Tables may be specified with optional factory cutouts for separately specified Flip Top Units for power.
- Most tables are available with optional Cable Bases for Power Management. Cable Bases may be also be used to support the top and reduce the number of legs needed (If Cable Base is removed during reconfiguration, ensure top is properly supported with legs at each corner and vertical support every 60").
- Perimeter Leg Conference Tables are standard with 2" thick tops.
- Tables with multiple piece tops will have equal sized pieces.
- 3mm Edgeband seams are standard on two and three-piece tops.
- Perimeter Leg Conference Tables are available with a wide variety of sizes to meet most seating capacity needs.

Edge Details

3mm Laminate Edgeband Edge

Top View

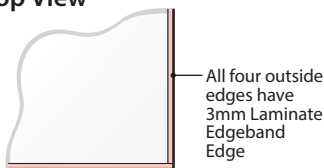

Front View

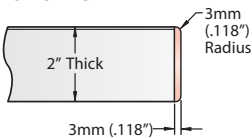

3mm Wood Edgeband Edge

Top View

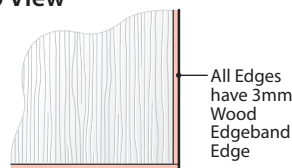

Front View

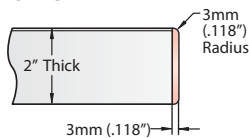

Core Material

2" Built Up Top – Engineered composite panel made with wood fiber, 100% of which is recycled fiber, bonded with resin. Table tops made with this core are compliant with GREENGUARD™ Standard for Low Emitting Products.

Product Details – Planes Perimeter Leg Conference Tables

Overview

Wood Grain Direction for Natural, Quarter Cut, Rift Cut and Double Cut Wood Veneer

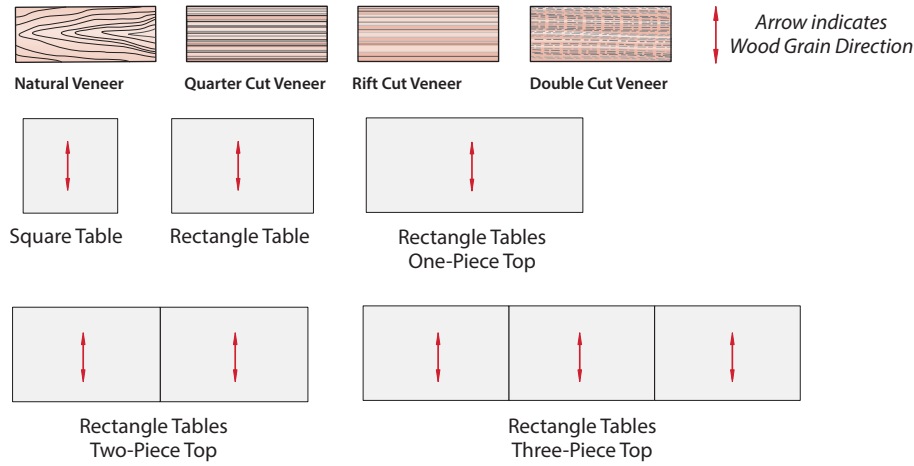

Interior Leg Conference Tables – Overview

Wood Grain Direction for Wood Grain Laminate

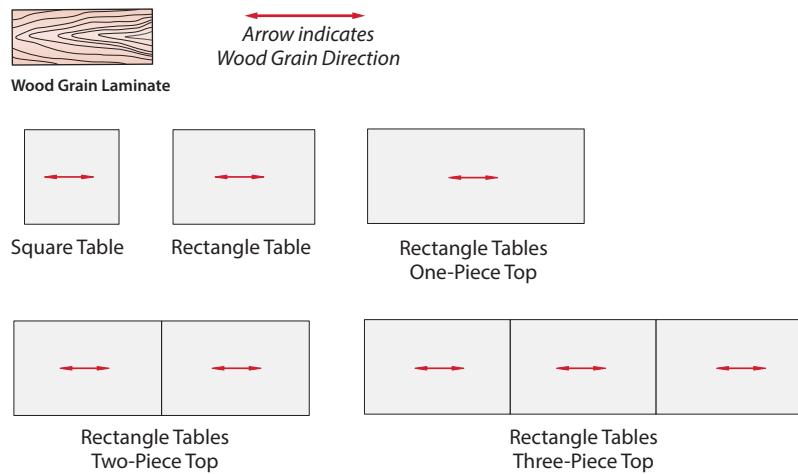

Note Laminate wood grain on multi-piece tops may not match.

Product Details – Planes Perimeter Leg Conference Tables

Square (One-Piece Top)

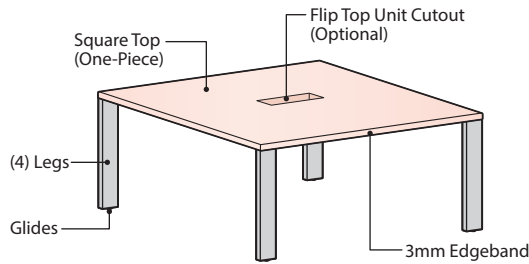

Flip Top Unit Cutout Options

Center Cutout Option
Includes 1 Flip Top Unit cutout (centered on top)

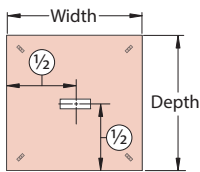

Cutout Option (F or V)
For use with Single Sided/ 4 Port Flip Top Unit

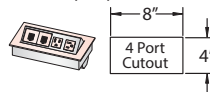

Cutout Option (J or K)
For use with Single Sided/ 6 Ports Flip Top Unit

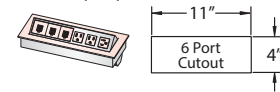

Cutout Option (M or P)
For use with Double Sided/ 8 Ports Flip Top Unit

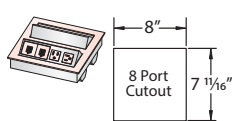

Cutout Option (Q or T)
For use with Double Sided/ 12 Ports Flip Top Unit

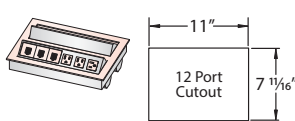

Note Flip Top Units are separately specified.

Component Materials/Finishes

COMPONENT NAME	MATERIALS/ FINISHES
Square Top Includes one-piece top.	Laminate Top – Specify separate finish colors for top and edge trim • Top is 2" thick. • Top is standard with 3mm laminate edgeband on user edges. Wood Top – Specify a single finish color for the top and edge trim • Top is 2" thick. • Top is standard with 3mm wood edgeband on user edges.
Perimeter Legs	Painted Metal – Specified Trim Color
Glides	Standard in Black

Dimensions

TABLETOP		KNEESPACE (Nominal)		
Width Nominal (Actual)	Depth Nominal (Actual)	(A)	(B)	(C)
42" (41.68")	42" (41.68")	21"	34"	39"
48" (47.68")	48" (47.68")	24"	40"	45"
54" (53.68")	54" (53.68")	27"	39"	51"
60" (59.68")	60" (59.68")	30"	52"	57"

Top View

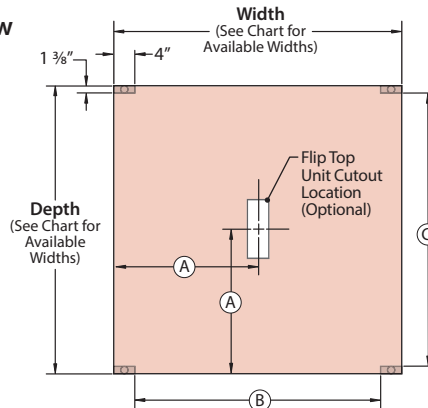

Front View

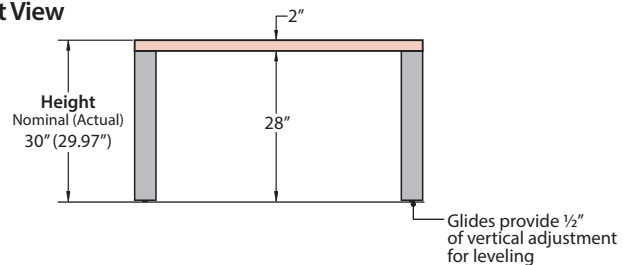

Table Sizes and Seating Capacities

TABLE SIZES		MAXIMUM NUMBER OF CHAIRS	
Depth Nominal (Actual)	Wide Nominal (Actual)		
42" (41.68")	42" (41.68")	4 Chairs Maximum (4 Legs)	
47" (46.68")	47" (46.68")	4 Chairs Maximum (4 Legs)	
54" (53.68")	54" (53.68")	4 Chairs Maximum (4 Legs)	
60" Deep	60" Wide	8 Chairs Maximum (4 Legs)	

Note

- Recommended seating capacity based upon a width of 27" per chair.
- Cable Bases are not recommended for One-Piece Square Tables, due to lack of kneespace clearance. Consider the separately specified Cable Column for cable management.

Product Details – Planes Perimeter Leg Conference Tables

Square (Two-Piece Top)

No Cable Base (Includes 6 Legs)

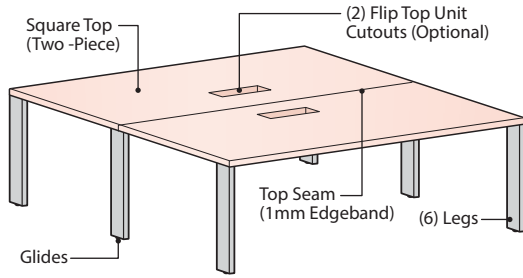

With Cable Base (Includes 4 Legs)

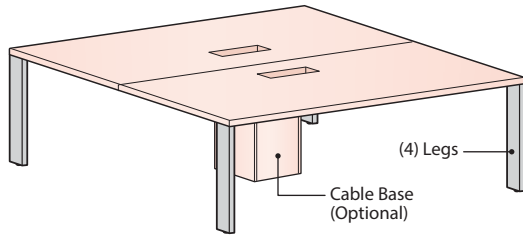

Flip Top Unit Cutout Options

Center Cutout Locations

Includes 2 Flip Top Unit cutouts (One cutout in each top piece)

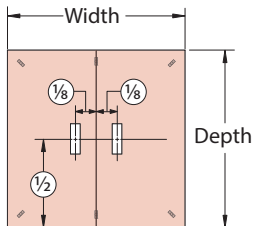

Cutout Option (F)

For use with Single Sided/4 Port

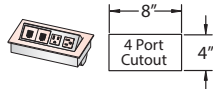

Cutout Option (J)

For use with Single Sided / 6 Ports Flip Top Unit

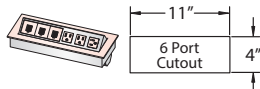

- Note**
- Double sided flip top units are not recommended with 2-Piece Square Tables.
 - Flip Top Units are separately specified.

Cable Base Options

- Two-Piece round tables may be specified with or without Cable Bases
 - (Option N) No Cable Base.
 - (Option C) Cable Base

Cable Base Size and Location

66" and 72" Deep Tables may be specified with an optional 14" x 14" Cable Base (Centered on top)

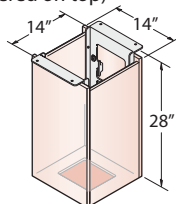
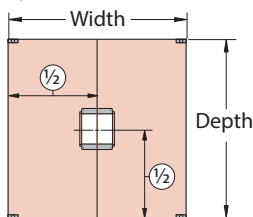

14" x 14" Cable Base

Component Materials/Finishes

COMPONENT NAME		MATERIALS/ FINISHES
Square Top Includes two-piece top.		Laminate Top – Specify separate finish colors for top and edge trim • Top is 2" thick. • Two-piece top is standard with 3mm laminate edgeband on user edges and 3mm edgeband on seam between tops.
		Wood Top – Specify a single finish color for the top and edge trim • Top is 2" thick. • Two-piece top is standard with 3mm wood edgeband on user edges and 3mm wood edgeband on seam between tops.
Perimeter Legs		Painted Metal – Specified Trim Color
Cable Base (Optional)	Panels	Laminate Panels – Specified surface and edge trim colors Wood Panels – Specified top and edge trim wood finish color
	Frame	Painted Metal – Standard in Black
Glides		Standard in Black

Dimensions

TABLETOP					KNEESPACE (Nominal)		
Width Nominal (Actual)	Depth Nominal (Actual)	A	B	C	D	E	F
66" (64.68")	66" (64.68")	33"	33"	8 1/4"	63"	27"	58"
72" (71.68")	72" (71.68")	36"	33"	9"	69"	30"	64"

No Cable Base – Includes (6) Legs
Top View

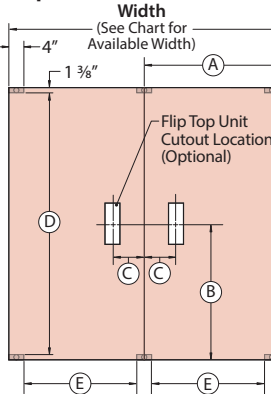

With Cable Base – Includes (4) Legs
Top View

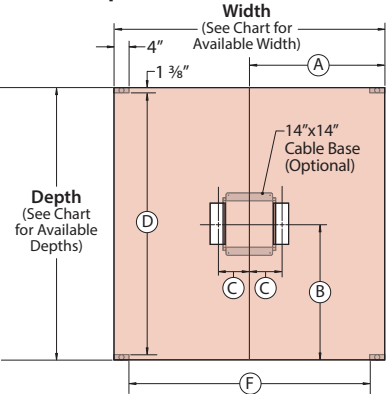

Front View

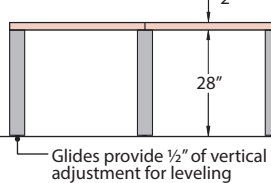

Front View

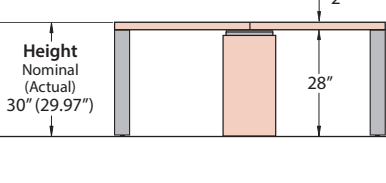
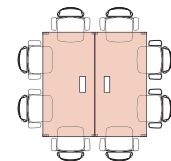

Table Sizes and Seating Capacities

TABLE SIZES		MAXIMUM NUMBER OF CHAIRS
Depth Nominal (Actual)	Wide Nominal (Actual)	
66" (65.68")	66" (65.68")	8 Chairs Maximum (6 Legs or 4 Legs/ 1 Cable Base)
72" (71.68")	72" (71.68")	8 Chairs Maximum (6 Legs or 4 Legs/ 1 Cable Base)



- Note**
- Recommended seating capacity based upon a width of 27" per chair.
 - Not recommended for use with workware switching Interface Module.

Product Details – Planes Perimeter Leg Conference Tables

Rectangular

**48"/54"/60"/66" Wide – Without Cable Base
Includes (4) Legs**

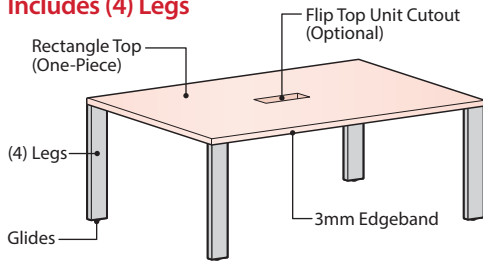

**48"/54"/60"/66" Wide – With Cable Base
Includes (4) Legs**

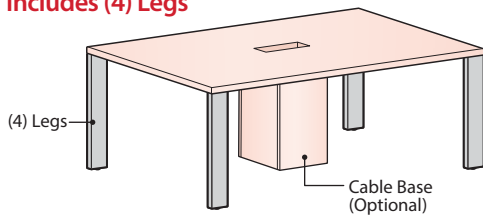

**72"/78" Wide – Without Cable Base
Includes (6) Legs**

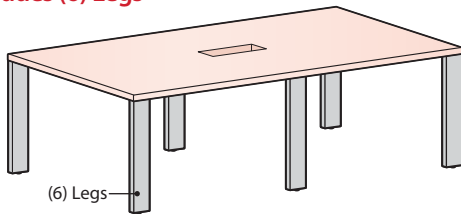

**72"/78" Wide – With Cable Base
Includes (4) Legs**

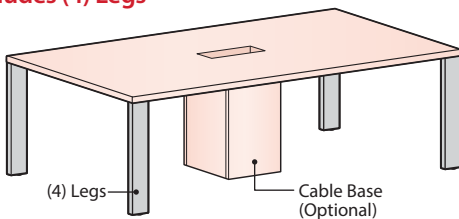

Component Materials/Finishes

COMPONENT NAME		MATERIALS/ FINISHES
Rectangle Top Includes one-piece top.		Laminate Top – Specify separate finish colors for top and edge trim • Top is 2" thick. • Top is standard with 3mm laminate edgeband on user edges.
		Wood Top – Specify a single finish color for the top and edge trim • Top is 2" thick. • Top is standard with 3mm wood edgeband on user edges.
Perimeter Legs		Painted Metal – Specified Trim Color
Glides		Standard in Black
Cable Base (Optional)	Panels	Laminate Panels – Specified surface and edge trim colors
	Frame	Painted Metal – Standard in Black

Flip Top Unit Cutout Options

Center Cutout Option

- Includes 1 Flip Top Unit cutout (centered on top)

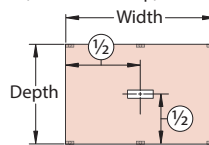

Left/Right Cutout Option

- Includes 2 Flip Top Unit cutouts (1 Left Cutout and 1 Right Cutout)

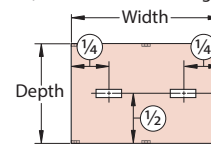

Cutout Option (F or V)

- For use with Single Sided/ 4 Port Flip Top Unit

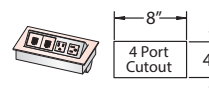

Cutout Option (J or K)

- For use with Single Sided/ 6 Ports Flip Top Unit

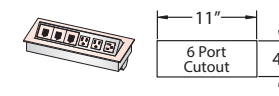

Cutout Option (M or P)

- For use with Double Sided/ 8 Ports Flip Top Unit

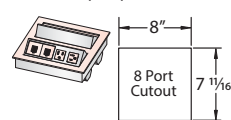

Cutout Option (Q or T)

- For use with Double Sided/ 12 Ports Flip Top Unit

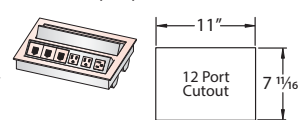

Note Flip Top Units are separately specified.

Cable Base Options

- Tables may be specified with or without Cable Bases
 - (Option N) No Cable Base.
 - (Option C) Cable Base

One-Piece Table with Cable Base option (Top View)

36" Deep Table Includes an 8" x 14" Cable Base (Centered on top)

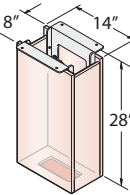
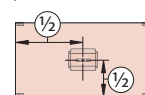

8" x 14" Cable Base

42", 48", 54", 60" Deep Tables Includes an 14" x 14" Cable Base (Centered on top)

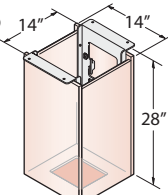
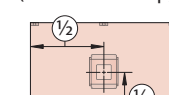

14" x 14" Cable Base

- Note**
- Cable Base option not recommended for 30" deep tables.
 - Cable base and table tops may be specified with different surface colors and edge trim colors.

Product Details – Planes Perimeter Leg Conference Tables

Rectangular

Dimensions – 48"-66" Wide – Without Cable Base
(Includes 4 Legs)

Top View

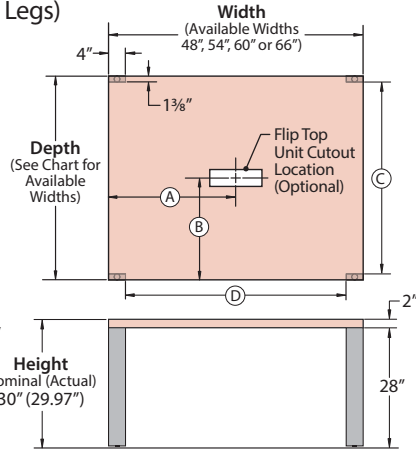

Front View

Dimensions – 72"-78" Wide – Without Cable Base
(Includes 6 Legs)

Top View

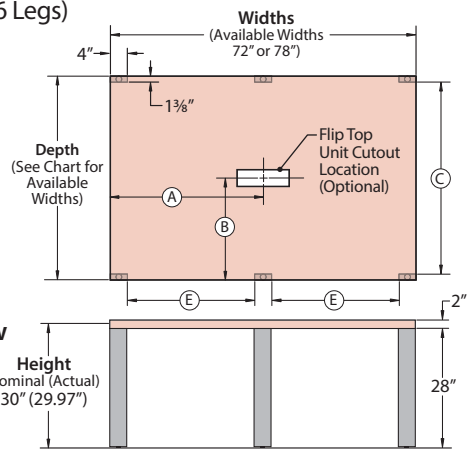

Front View

48"/54"/60"/66" Wide – With Cable Base
(Includes 4 Legs)

Top View

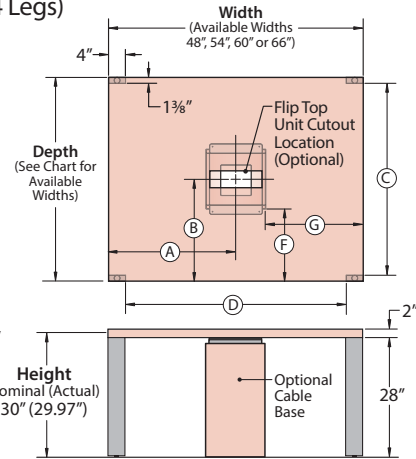

Front View

72"/78" Wide – With Cable Base
(Includes 4 Legs)

Top View

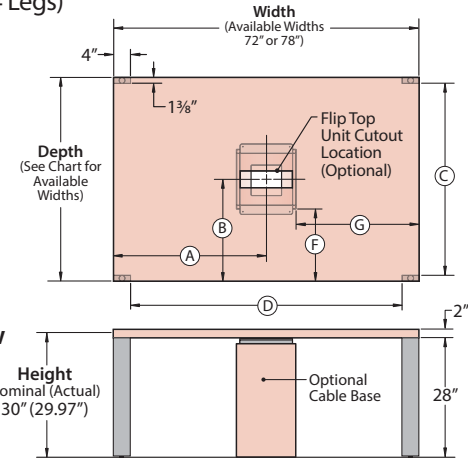

Front View

Note The optional Cable Base reduces the number of legs shipped with 72" and 78" Wide Tables to (4) legs.

Dimensions

TABLETOP				KNEESPACE (Nominal)						CABLE BASE		
Depth Nominal (Actual)	Width Nominal (Actual)	Number of Top Pieces	A	B	C	D	E	F	G	Optional Cable Base Size/ Availability	Number of Legs Without Cable Base	Number of Legs With Cable Base
30" (29.68")	60" (59.68")	1	30"	15"	27"	52"	N/A	N/A	N/A	Not Available	4	N/A
	66" (65.68")	1	33"	15"	27"	58"	N/A	N/A	N/A	Not Available	4	N/A
	72" (71.68")	1	36"	15"	27"	64"	30"	N/A	N/A	Not Available	6	N/A
36" (35.68")	60" (59.68")	1	30"	16"	33"	52"	N/A	14"	23"	8" D x 16" W	4	4
	66" (65.68")	1	33"	16"	33"	58"	N/A	14"	26"	8" D x 16" W	4	4
42" (41.68")	48" (47.68")	1	24"	21"	39"	40"	N/A	14"	17"	16" D x 16" W	4	4
	54" (53.68")	1	27"	21"	39"	46"	N/A	14"	20"	16" D x 16" W	4	4
	60" (59.68")	1	30"	21"	39"	52"	N/A	14"	23"	16" D x 16" W	4	4
	66" (65.68")	1	33"	21"	39"	58"	N/A	14"	26"	16" D x 16" W	4	4
	72" (71.68")	1	36"	21"	39"	64"	30"	14"	29"	16" D x 16" W	6	4
	78" (77.68")	1	39"	21"	39"	70"	33"	14"	32"	16" D x 16" W	6	4
48" (47.68")	54" (53.68")	1	27"	24"	45"	46"	N/A	17"	20"	16" D x 16" W	4	4
	60" (59.68")	1	30"	24"	45"	52"	N/A	17"	23"	16" D x 16" W	4	4
	66" (65.68")	1	33"	24"	45"	58"	N/A	17"	26"	16" D x 16" W	4	4
	72" (71.68")	1	36"	24"	45"	64"	30"	17"	29"	16" D x 16" W	6	4
54" (53.68")	60" (59.68")	1	30"	27"	51"	52"	N/A	20"	23"	16" D x 16" W	4	4
	66" (65.68")	1	33"	27"	51"	58"	N/A	20"	26"	16" D x 16" W	4	4
	72" (71.68")	1	36"	27"	51"	64"	30"	20"	29"	16" D x 16" W	6	4
	78" (77.68")	1	39"	27"	51"	70"	33"	20"	32"	16" D x 16" W	6	4
60" (59.68")	66" (65.68")	1	33"	30"	57"	58"	N/A	23"	26"	16" D x 16" W	4	4
	72" (71.68")	1	36"	30"	57"	64"	30"	23"	29"	16" D x 16" W	6	4
60" (59.68")	72" (71.68")	1	39"	30"	57"	70"	33"	23"	32"	16" D x 16" W	6	4

Note

- For optional Flip Top Unit Cutout sizes and dimensions see previous page.
- 36" tables are available with 8"D x 16"W Cable Bases, which are not compatible with Double Sided Flip Top Unit Cutouts (M) or (Q).
- Cable Base option not recommended for 30" deep tables, consider the separately specified Cable Column for cable management.

Product Details – Planes Perimeter Leg Conference Tables

Rectangular

Table Sizes and Seating Capacities – Without Cable Bases

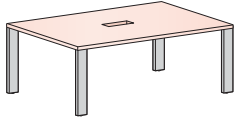

48"-66" wide Rectangle Tables specified without a Cable Base are standard with 4 Legs.

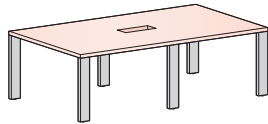

72"-78" wide Rectangle Tables specified without a Cable Base are standard with 6 Legs.

		WIDTHS					
		48" Wide	54" Wide	60" Wide	66" Wide	72" Wide	78" Wide
DEPTHS	30" Deep	N/A	N/A				N/A
	36" Deep	N/A	N/A			N/A	N/A
	42" Deep						
	48" Deep	N/A					
	54" Deep	N/A	N/A				
	60" Deep	N/A	N/A	N/A			

Table Sizes and Seating Capacities – With Cable Bases

- Optional Cable Bases function as a top support allowing tables with (6) legs to be reduced down to (4) Legs.
- 36" Deep Tables specified with a Cable Base ship with a 8" x 14" Cable Base.
- 42"-60" Deep Tables specified with a Cable Base ship with a 14" x 14" Cable Base.

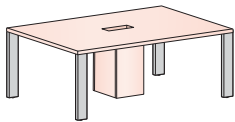

48"-66" wide Rectangle Tables specified with a Cable Base are standard with 4 Legs.

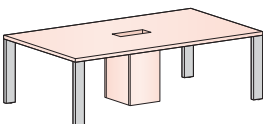

72"-78" wide Rectangle Tables specified with a Cable Base are standard with 4 Legs.

		WIDTHS					
		48" Wide	54" Wide	60" Wide	66" Wide	72" Wide	78" Wide
DEPTHS	30" Deep	N/A	N/A				N/A
	36" Deep	N/A	N/A			N/A	N/A
	42" Deep						
	48" Deep	N/A					
	54" Deep	N/A	N/A				
	60" Deep	N/A	N/A	N/A			

Note Recommended seating capacity based upon a width of 27" per chair.

Product Details – Planes Perimeter Leg Conference Tables

Rectangular (One-Piece Top)

Without Cable Base – Includes (6) Legs

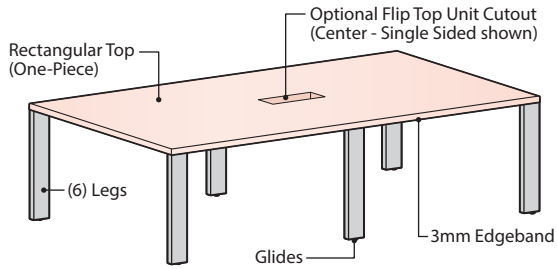

With Cable Base – Includes (4) Legs

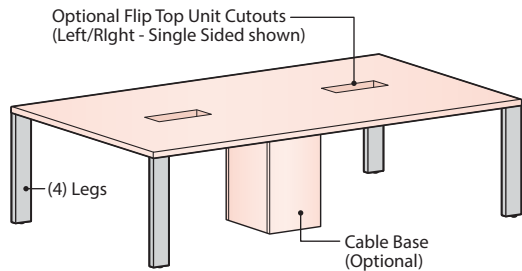

Component Materials/Finishes

COMPONENT NAME	MATERIALS/ FINISHES
Rectangle Top Includes one-piece top.	Laminate Top – Specify separate finish colors for top and edge trim • Top is 2" thick. • Top is standard with 3mm laminate edgeband on user edges.
	Wood Top – Specify a single finish color for the top and edge trim • Top is 2" thick. • Top is standard with 3mm wood edgeband on user edges.
Perimeter Legs	Painted Metal – Specified Trim Color
Glides	Standard in Black
Cable Base (Optional)	Panels Laminate Panels – Specified surface and edge trim colors Wood Panels – Specified top and edge trim wood finish color
	Frame Painted Metal – Standard in Black

Flip Top Unit Cutout Options

Center Cutout Option

- Includes 1 Flip Top Unit cutout (centered on top)

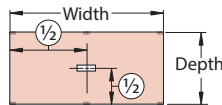

Left/Right Cutout Option

- Includes 2 Flip Top Unit cutouts (1 Left Cutout and 1 Right Cutout)

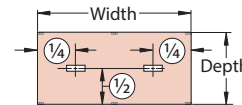

Cutout Option (F or V)

- For use with Single Sided/ 4 Port Flip Top Unit

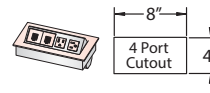

Cutout Option (J or K)

- For use with Single Sided/ 6 Ports Flip Top Unit

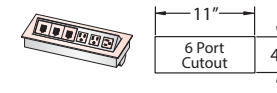

Cutout Option (M or P)

- For use with Double Sided/ 8 Ports Flip Top Unit

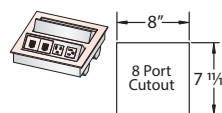

Cutout Option (Q or T)

- For use with Double Sided/ 12 Ports Flip Top Unit

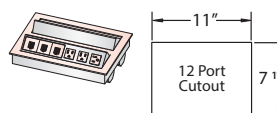

Note Flip Top Units are separately specified.

Cable Base Options

- Tables may be specified with or without Cable Bases
 - (Option N) No Cable Base.
 - (Option C) 36" deep table includes 8" x 14" Cable Base
42", 48", 54" and 60" deep table includes 14" x 14" Cable Base

One-Piece Table with Cable Base option (Top View)

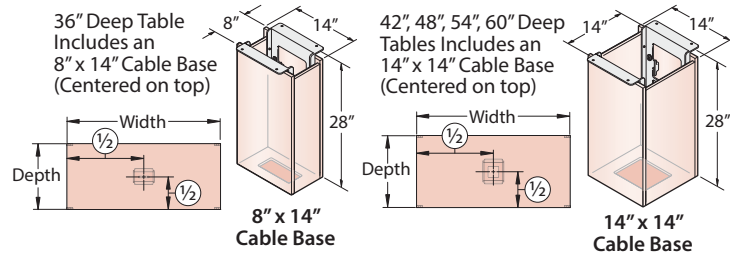

Product Details – Planes Perimeter Leg Conference Tables

Rectangular (One-Piece Top)

Dimensions – Without Cable Base – Includes (6) Legs

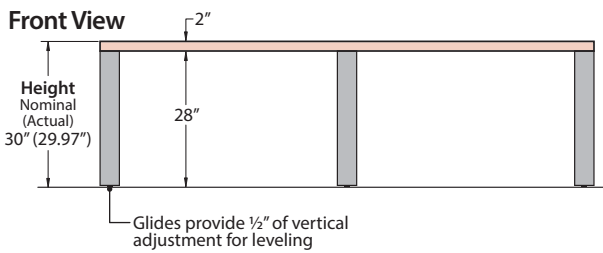
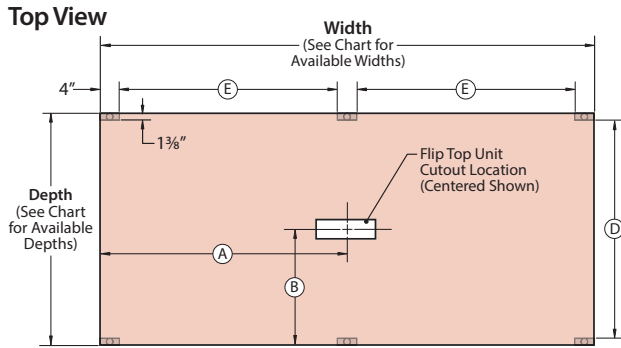

Dimensions – With Cable Base – Includes (4) Legs

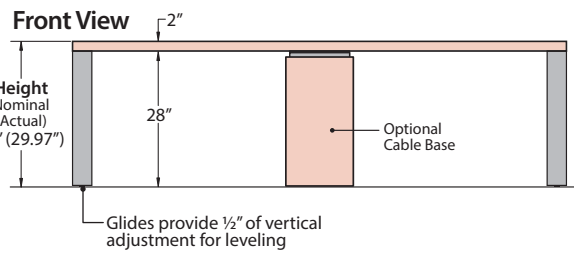
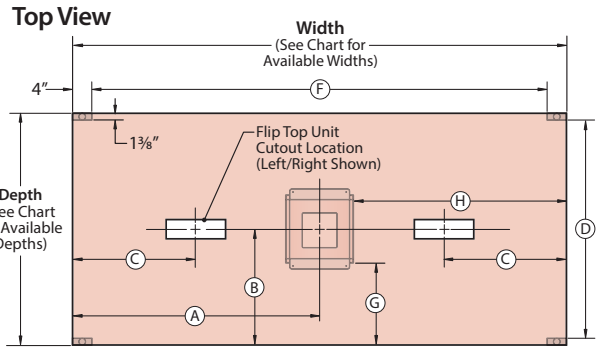

Dimensions

TABLETOP			KNEESPACE (Nominal)			LEGS		CABLE BASE					
Depth Nominal (Actual)	Width Nominal (Actual)	Number of Top Pieces	A	B	C	D	E	F	Number of Legs Without Cable Base	Number of Legs With Cable Base	Optional Cable Base Sizes	G	H
36" (35.68")	72" (71.68")	1	36"	18"	18"	33"	30"	64"	6	4	8" D x 16" W	14"	29"
	78" (77.68")	1	39"	18"	19 1/2"	33"	33"	70"	6	4	8" D x 16" W	14"	32"
	84" (83.68")	1	42"	18"	21"	33"	36"	76"	6	4	8" D x 16" W	14"	35"
	90" (89.68")	1	45"	18"	22 1/2"	33"	39"	82"	6	4	8" D x 16" W	14"	38"
	96" (95.68")	1	48"	18"	24"	33"	42"	88"	6	4	8" D x 16" W	14"	41"
42" (41.68")	84" (83.68")	1	42"	21"	21"	39"	36"	76"	6	4	16" D x 16" W	14"	32"
	90" (89.68")	1	45"	21"	22 1/2"	39"	39"	82"	6	4	16" D x 16" W	14"	35"
	96" (95.68")	1	48"	21"	24"	39"	42"	88"	6	4	16" D x 16" W	14"	38"
	102" (101.68")	1	51"	21"	25 1/2"	39"	45"	94"	6	4	16" D x 16" W	14"	41"
	108" (107.68")	1	54"	21"	27"	39"	48"	100"	6	4	16" D x 16" W	14"	47"
	114" (113.68")	1	57"	21"	28 1/2"	39"	51"	106"	6	4	16" D x 16" W	14"	50"
48" (47.68")	84" (83.68")	1	42"	24"	21"	45"	36"	76"	6	4	16" D x 16" W	17"	32"
	90" (89.68")	1	45"	24"	22 1/2"	45"	39"	82"	6	4	16" D x 16" W	17"	35"
	96" (95.68")	1	48"	24"	24"	45"	42"	88"	6	4	16" D x 16" W	17"	38"
	102" (101.68")	1	51"	24"	25 1/2"	45"	45"	94"	6	4	16" D x 16" W	17"	41"
	108" (107.68")	1	54"	24"	27"	45"	48"	100"	6	4	16" D x 16" W	17"	47"
	114" (113.68")	1	57"	24"	28 1/2"	45"	51"	106"	6	4	16" D x 16" W	17"	50"
54" (53.68")	84" (83.68")	1	42"	27"	21"	51"	36"	76"	6	4	16" D x 16" W	20"	32"
	90" (89.68")	1	45"	27"	22 1/2"	51"	39"	82"	6	4	16" D x 16" W	20"	35"
	96" (95.68")	1	48"	27"	24"	51"	42"	88"	6	4	16" D x 16" W	20"	38"
	102" (101.68")	1	51"	27"	25 1/2"	51"	45"	94"	6	4	16" D x 16" W	20"	41"
	108" (107.68")	1	54"	27"	27"	51"	48"	100"	6	4	16" D x 16" W	20"	47"
	114" (113.68")	1	57"	27"	28 1/2"	51"	51"	106"	6	4	16" D x 16" W	20"	50"
60" (59.68")	84" (83.68")	1	42"	30"	21"	57"	36"	76"	6	4	16" D x 16" W	23"	32"
	90" (89.68")	1	45"	30"	22 1/2"	57"	39"	82"	6	4	16" D x 16" W	23"	35"
	96" (95.68")	1	48"	30"	24"	57"	42"	88"	6	4	16" D x 16" W	23"	38"
	102" (101.68")	1	51"	30"	25 1/2"	57"	45"	94"	6	4	16" D x 16" W	23"	41"
	108" (107.68")	1	54"	30"	27"	57"	48"	100"	6	4	16" D x 16" W	23"	47"
	114" (113.68")	1	57"	30"	28 1/2"	57"	51"	106"	6	4	16" D x 16" W	23"	50"
120" (119.68")	1	60"	30"	30"	57"	54"	112"	6	4	16" D x 16" W	23"	53"	

Product Details – Planes Perimeter Leg Conference Tables

Rectangular (One-Piece Top)

Table Sizes and Seating Capacities – Without Cable Bases – Includes (6) Legs

• One-Piece Top Tables specified without a Cable Base are standard with 6 Legs.

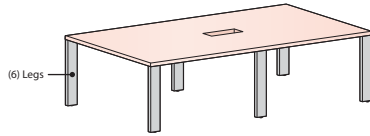

		WIDTHS								
		72" Wide	78" Wide	84" Wide	90" Wide	96" Wide	102" Wide	108" Wide	114" Wide	120" Wide
DEPTHS	36" Deep	 6 Chairs Maximum	 6 Chairs Maximum	 6 Chairs Maximum	 6 Chairs Maximum	 6 Chairs Maximum	N/A	N/A	N/A	N/A
	42" Deep	N/A	N/A	 6 Chairs Maximum	 6 Chairs Maximum	 6 Chairs Maximum	 6 Chairs Maximum	 12 Chairs Maximum	 10 Chairs Maximum	 10 Chairs Maximum
	48" Deep	N/A	N/A	 6 Chairs Maximum	 6 Chairs Maximum	 6 Chairs Maximum	 6 Chairs Maximum	 12 Chairs Maximum	 10 Chairs Maximum	 10 Chairs Maximum
	54" Deep	N/A	N/A	 8 Chairs Maximum	 8 Chairs Maximum	 8 Chairs Maximum	 8 Chairs Maximum	 12 Chairs Maximum	 12 Chairs Maximum	 12 Chairs Maximum
	60" Deep	N/A	N/A	 8 Chairs Maximum	 8 Chairs Maximum	 8 Chairs Maximum	 8 Chairs Maximum	 12 Chairs Maximum	 12 Chairs Maximum	 12 Chairs Maximum

Table Sizes and Seating Capacities – With Cable Bases – Includes (4) Legs

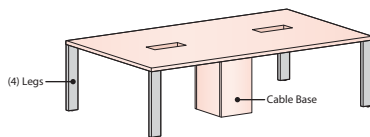

- Optional Cable Bases function as a top support allowing the number of legs to be reduced from (6) Legs down to (4) Legs.
- 36" Deep Tables specified with a Cable Base ship with a 8" x 14" Cable Base.
- 42"-60" Deep Tables specified with a Cable Base ship with a 14" x 14" Cable Base.

		WIDTHS								
		72" Wide	78" Wide	84" Wide	90" Wide	96" Wide	102" Wide	108" Wide	114" Wide	120" Wide
DEPTHS	36" Deep	 6 Chairs Maximum	 6 Chairs Maximum	 8 Chairs Maximum	 8 Chairs Maximum	 8 Chairs Maximum	N/A	N/A	N/A	N/A
	42" Deep	N/A	N/A	 8 Chairs Maximum	 8 Chairs Maximum	 8 Chairs Maximum	 8 Chairs Maximum	 10 Chairs Maximum	 10 Chairs Maximum	 10 Chairs Maximum
	48" Deep	N/A	N/A	 8 Chairs Maximum	 8 Chairs Maximum	 8 Chairs Maximum	 8 Chairs Maximum	 10 Chairs Maximum	 10 Chairs Maximum	 10 Chairs Maximum
	54" Deep	N/A	N/A	 10 Chairs Maximum	 10 Chairs Maximum	 10 Chairs Maximum	 10 Chairs Maximum	 12 Chairs Maximum	 12 Chairs Maximum	 12 Chairs Maximum
	60" Deep	N/A	N/A	 10 Chairs Maximum	 10 Chairs Maximum	 10 Chairs Maximum	 10 Chairs Maximum	 12 Chairs Maximum	 12 Chairs Maximum	 12 Chairs Maximum

Note Recommended seating capacity based upon a width of 27" per chair.

Product Details – Planes Perimeter Leg Conference Tables

Rectangular (Two-Piece Top)

Without Cable Base

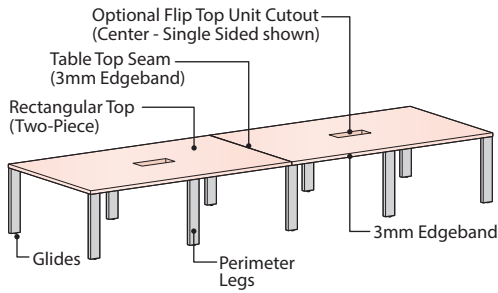

With Cable Base

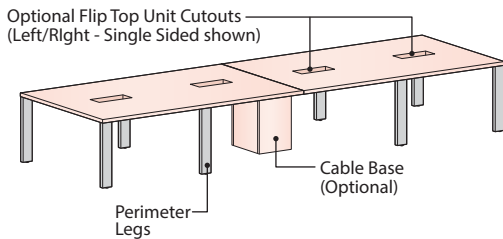

Component Materials/Finishes

COMPONENT NAME	MATERIALS/ FINISHES
Rectangle Top 2-Piece Top	Laminate Top – Specify separate finish colors for top and edge trim • Top is 2" thick. • Two-piece top is standard with 3mm laminate edgeband on user edges and 3mm edgeband on seam between tops.
	Wood Top – Specify a single finish color for the top and edge trim • Top is 2" thick. • Two-piece top is standard with 3mm wood edgeband on user edges and 3mm wood edgeband on seam between tops.
Perimeter Legs	Painted Metal – Specified Trim Color
Glides	Standard in Black
Cable Base (Optional)	Panels
	Frame
	Laminate Panels – Specified surface and edge trim colors
	Wood Panels – Specified top and edge trim wood finish color
	Painted Metal – Standard in Black

Flip Top Unit Cutout Options

Center Cutout Option

- Includes 3 Flip Top Unit cutouts (1 Cutout centered on each top piece)

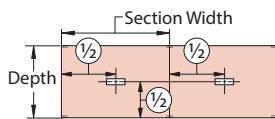

Left/Right Cutout Option

- Includes 6 Flip Top Unit cutouts (2 Cutouts on each top piece)

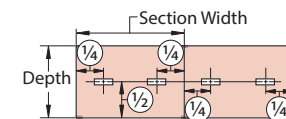

Cutout Option (F or V)

- For use with Single Sided/ 4 Port Flip Top Unit

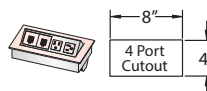

Cutout Option (J or K)

- For use with Single Sided/ 6 Ports Flip Top Unit

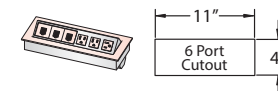

Cutout Option (M or P)

- For use with Double Sided/ 8 Ports Flip Top Unit

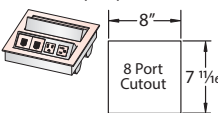

Cutout Option (Q or T)

- For use with Double Sided/ 12 Ports Flip Top Unit

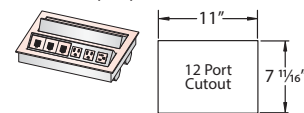

Note Flip Top Units are separately specified.

Cable Base Options

- Tables may be specified with or without Cable Bases
 - (Option N) No Cable Base.
 - (Option C) Includes 14" x 14" Cable Bases

Two-Piece Table with Cable Base option (Top View)

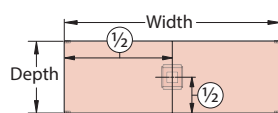

Cable Base is centered on the seam between top pieces.

14" x 14" Cable Base

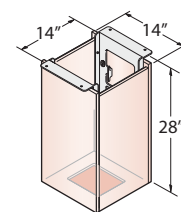

Product Details – Planes Perimeter Leg Conference Tables

Rectangular (Two-Piece Top)

**Dimensions – 126"-132" Wide
Tables Without Cable Base
Includes (6) Legs**

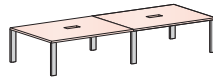

Top View

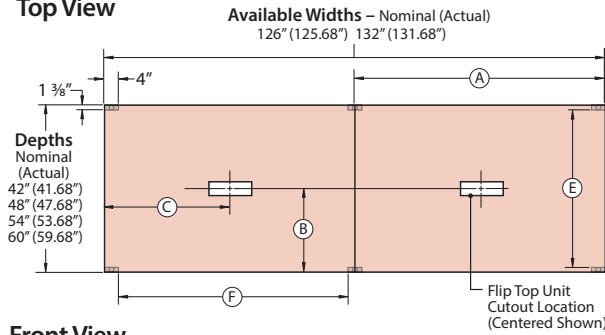

Front View

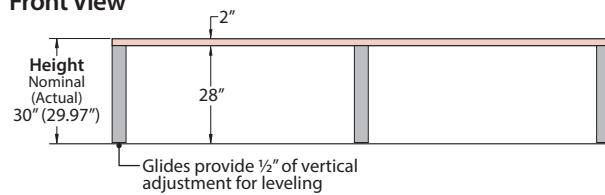

**Dimensions – 138"-180" Wide
Tables Without Cable Base
Includes (10) Legs**

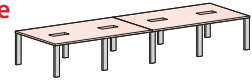

Top View

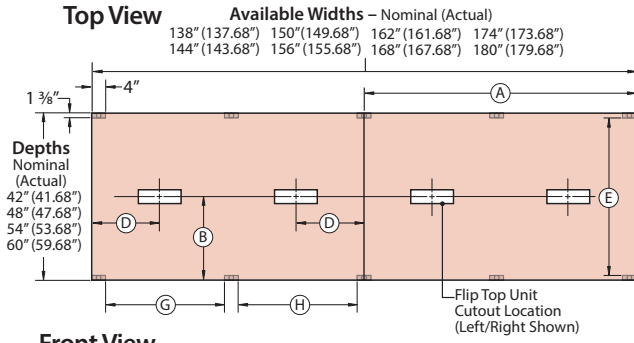

Front View

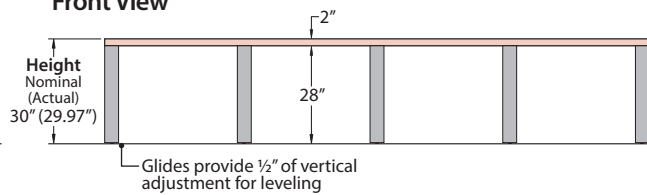

Dimensions

Depth Nominal (Actual)	TABLETOP						KNEESPACE (Nominal)				LEGS
	Width Nominal (Actual)	Number of Top Pieces	A	B	C	D	E	F	G	H	Number of Legs Without Cable Base
42" (41.68")	126" (125.68")	2	63"	21"	31 1/2"	15 3/4"	39"	57"	N/A	N/A	6
	132" (131.68")	2	66"	21"	33"	16 1/2"	39"	60"	N/A	N/A	6
	138" (137.68")	2	69"	21"	34 1/2"	17 1/4"	39"	N/A	28"	30"	10
	144" (143.68")	2	72"	21"	36"	18"	39"	N/A	30"	32"	10
	150" (149.68")	2	75"	21"	37 1/2"	18 3/4"	39"	N/A	31"	33"	10
	156" (155.68")	2	78"	21"	39"	19 1/2"	39"	N/A	33"	35"	10
	162" (161.68")	2	81"	21"	40 1/2"	20 1/4"	39"	N/A	34"	36"	10
	168" (167.68")	2	84"	21"	42"	21"	39"	N/A	36"	38"	10
	174" (173.68")	2	87"	21"	43 1/2"	21 3/4"	39"	N/A	37"	39"	10
48" (47.68")	126" (125.68")	2	63"	24"	31 1/2"	15 3/4"	45"	57"	N/A	N/A	6
	132" (131.68")	2	66"	24"	33"	16 1/2"	45"	60"	N/A	N/A	6
	138" (137.68")	2	69"	24"	34 1/2"	17 1/4"	45"	N/A	28"	30"	10
	144" (143.68")	2	72"	24"	36"	18"	45"	N/A	30"	32"	10
	150" (149.68")	2	75"	24"	37 1/2"	18 3/4"	45"	N/A	31"	33"	10
	156" (155.68")	2	78"	24"	39"	19 1/2"	45"	N/A	33"	35"	10
	162" (161.68")	2	81"	24"	40 1/2"	20 1/4"	45"	N/A	34"	36"	10
	168" (167.68")	2	84"	24"	42"	21"	45"	N/A	36"	38"	10
	174" (173.68")	2	87"	24"	43 1/2"	21 3/4"	45"	N/A	37"	39"	10
54" (53.68")	126" (125.68")	2	63"	27"	31 1/2"	15 3/4"	51"	57"	N/A	N/A	6
	132" (131.68")	2	66"	27"	33"	16 1/2"	51"	60"	N/A	N/A	6
	138" (137.68")	2	69"	27"	34 1/2"	17 1/4"	51"	N/A	28"	30"	10
	144" (143.68")	2	72"	27"	36"	18"	51"	N/A	30"	32"	10
	150" (149.68")	2	75"	27"	37 1/2"	18 3/4"	51"	N/A	31"	33"	10
	156" (155.68")	2	78"	27"	39"	19 1/2"	51"	N/A	33"	35"	10
	162" (161.68")	2	81"	27"	40 1/2"	20 1/4"	51"	N/A	34"	36"	10
	168" (167.68")	2	84"	27"	42"	21"	51"	N/A	36"	38"	10
	174" (173.68")	2	87"	27"	43 1/2"	21 3/4"	51"	N/A	37"	39"	10
60" (59.68")	126" (125.68")	2	63"	30"	31 1/2"	15 3/4"	57"	57"	N/A	N/A	6
	132" (131.68")	2	66"	30"	33"	16 1/2"	57"	60"	N/A	N/A	6
	138" (137.68")	2	69"	30"	34 1/2"	17 1/4"	57"	N/A	28"	30"	10
	144" (143.68")	2	72"	30"	36"	18"	57"	N/A	30"	32"	10
	150" (149.68")	2	75"	30"	37 1/2"	18 3/4"	57"	N/A	31"	33"	10
	156" (155.68")	2	78"	30"	39"	19 1/2"	57"	N/A	33"	35"	10
	162" (161.68")	2	81"	30"	40 1/2"	20 1/4"	57"	N/A	34"	36"	10
	168" (167.68")	2	84"	30"	42"	21"	57"	N/A	36"	38"	10
	174" (173.68")	2	87"	30"	43 1/2"	21 3/4"	57"	N/A	37"	39"	10
180" (179.68")	2	90"	30"	45"	22 1/2"	57"	N/A	39"	41"	10	

Product Details – Planes Perimeter Leg Conference Tables

Rectangular (Two-Piece Top)

**Dimensions – 126"-132" Wide
Tables With Cable Base
Includes (4) Legs**

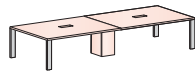

Top View

Available Widths – Nominal (Actual)
126" (125.68") 132" (131.68")

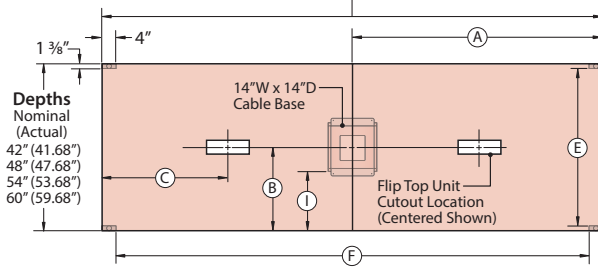

Front View

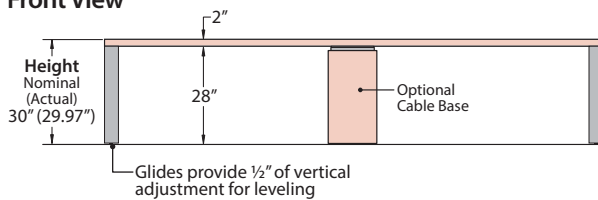

**Dimensions – 138"-180" Wide
Tables With Cable Base
Includes (8) Legs**

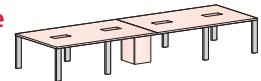

Top View

Available Widths – Nominal (Actual)
138" (137.68") 150" (149.68") 162" (161.68") 174" (176.68")
144" (143.68") 156" (155.68") 168" (167.68") 180" (179.68")

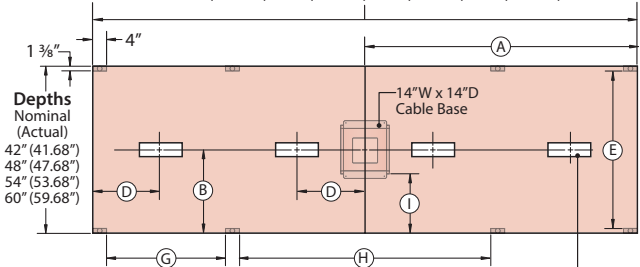

Front View

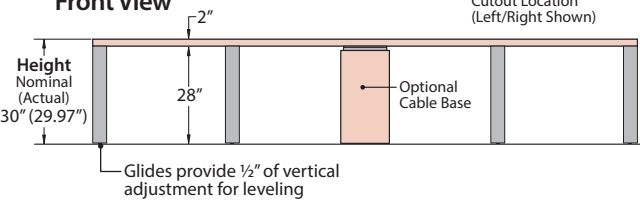

Dimensions

TABLETOP		KNEESPACE (Nominal)					LEGS		CABLE BASE				
Depth Nominal (Actual)	Width Nominal (Actual)	Number of Top Pieces	A	B	C	D	E	F	G	H	I	Number of Legs With Cable Base	Optional Cable Base Sizes
42" (41.68")	126" (125.68")	2	63"	21"	31 1/2"	15 3/4"	39"	118"	N/A	N/A	14"	4	16" D x 16" W
	132" (131.68")	2	66"	21"	33"	16 1/2"	39"	124"	N/A	N/A	14"	4	16" D x 16" W
	138" (137.68")	2	69"	21"	34 1/2"	17 1/4"	39"	N/A	28"	65"	14"	8	16" D x 16" W
	144" (143.68")	2	72"	21"	36"	18"	39"	N/A	30"	68"	14"	8	16" D x 16" W
	150" (149.68")	2	75"	21"	37 1/2"	18 3/4"	39"	N/A	31"	71"	14"	8	16" D x 16" W
	156" (155.68")	2	78"	21"	39"	19 1/2"	39"	N/A	33"	73"	14"	8	16" D x 16" W
	162" (161.68")	2	81"	21"	40 1/2"	20 1/4"	39"	N/A	34"	75"	14"	8	16" D x 16" W
	168" (167.68")	2	84"	21"	42"	21"	39"	N/A	36"	78"	14"	8	16" D x 16" W
	174" (173.68")	2	87"	21"	43 1/2"	21 3/4"	39"	N/A	37"	81"	14"	8	16" D x 16" W
48" (47.68")	126" (125.68")	2	63"	24"	31 1/2"	15 3/4"	45"	118"	N/A	N/A	17"	4	16" D x 16" W
	132" (131.68")	2	66"	24"	33"	16 1/2"	45"	124"	N/A	N/A	17"	4	16" D x 16" W
	138" (137.68")	2	69"	24"	34 1/2"	17 1/4"	45"	N/A	28"	65"	17"	8	16" D x 16" W
	144" (143.68")	2	72"	24"	36"	18"	45"	N/A	30"	68"	17"	8	16" D x 16" W
	150" (149.68")	2	75"	24"	37 1/2"	18 3/4"	45"	N/A	31"	71"	17"	8	16" D x 16" W
	156" (155.68")	2	78"	24"	39"	19 1/2"	45"	N/A	33"	73"	17"	8	16" D x 16" W
	162" (161.68")	2	81"	24"	40 1/2"	20 1/4"	45"	N/A	34"	75"	17"	8	16" D x 16" W
	168" (167.68")	2	84"	24"	42"	21"	45"	N/A	36"	78"	17"	8	16" D x 16" W
	174" (173.68")	2	87"	24"	43 1/2"	21 3/4"	45"	N/A	37"	81"	17"	8	16" D x 16" W
54" (53.68")	126" (125.68")	2	63"	27"	31 1/2"	15 3/4"	51"	118"	N/A	N/A	20"	4	16" D x 16" W
	132" (131.68")	2	66"	27"	33"	16 1/2"	51"	124"	N/A	N/A	20"	4	16" D x 16" W
	138" (137.68")	2	69"	27"	34 1/2"	17 1/4"	51"	N/A	28"	65"	20"	8	16" D x 16" W
	144" (143.68")	2	72"	27"	36"	18"	51"	N/A	30"	68"	20"	8	16" D x 16" W
	150" (149.68")	2	75"	27"	37 1/2"	18 3/4"	51"	N/A	31"	71"	20"	8	16" D x 16" W
	156" (155.68")	2	78"	27"	39"	19 1/2"	51"	N/A	33"	73"	20"	8	16" D x 16" W
	162" (161.68")	2	81"	27"	40 1/2"	20 1/4"	51"	N/A	34"	75"	20"	8	16" D x 16" W
	168" (167.68")	2	84"	27"	42"	21"	51"	N/A	36"	78"	20"	8	16" D x 16" W
	174" (173.68")	2	87"	27"	43 1/2"	21 3/4"	51"	N/A	37"	81"	20"	8	16" D x 16" W
60" (59.68")	126" (125.68")	2	63"	30"	31 1/2"	15 3/4"	57"	118"	N/A	N/A	23"	4	16" D x 16" W
	132" (131.68")	2	66"	30"	33"	16 1/2"	57"	124"	N/A	N/A	23"	4	16" D x 16" W
	138" (137.68")	2	69"	30"	34 1/2"	17 1/4"	57"	N/A	28"	65"	23"	8	16" D x 16" W
	144" (143.68")	2	72"	30"	36"	18"	57"	N/A	30"	68"	23"	8	16" D x 16" W
	150" (149.68")	2	75"	30"	37 1/2"	18 3/4"	57"	N/A	31"	71"	23"	8	16" D x 16" W
	156" (155.68")	2	78"	30"	39"	19 1/2"	57"	N/A	33"	73"	23"	8	16" D x 16" W
	162" (161.68")	2	81"	30"	40 1/2"	20 1/4"	57"	N/A	34"	75"	23"	8	16" D x 16" W
	168" (167.68")	2	84"	30"	42"	21"	57"	N/A	36"	78"	23"	8	16" D x 16" W
	174" (173.68")	2	87"	30"	43 1/2"	21 3/4"	57"	N/A	37"	81"	23"	8	16" D x 16" W
60" (59.68")	126" (125.68")	2	63"	30"	31 1/2"	15 3/4"	57"	118"	N/A	N/A	23"	4	16" D x 16" W
	132" (131.68")	2	66"	30"	33"	16 1/2"	57"	124"	N/A	N/A	23"	4	16" D x 16" W
	138" (137.68")	2	69"	30"	34 1/2"	17 1/4"	57"	N/A	28"	65"	23"	8	16" D x 16" W
	144" (143.68")	2	72"	30"	36"	18"	57"	N/A	30"	68"	23"	8	16" D x 16" W
	150" (149.68")	2	75"	30"	37 1/2"	18 3/4"	57"	N/A	31"	71"	23"	8	16" D x 16" W
	156" (155.68")	2	78"	30"	39"	19 1/2"	57"	N/A	33"	73"	23"	8	16" D x 16" W
	162" (161.68")	2	81"	30"	40 1/2"	20 1/4"	57"	N/A	34"	75"	23"	8	16" D x 16" W
	168" (167.68")	2	84"	30"	42"	21"	57"	N/A	36"	78"	23"	8	16" D x 16" W
	174" (173.68")	2	87"	30"	43 1/2"	21 3/4"	57"	N/A	37"	81"	23"	8	16" D x 16" W
60" (59.68")	126" (125.68")	2	63"	30"	31 1/2"	15 3/4"	57"	118"	N/A	N/A	23"	4	16" D x 16" W
	132" (131.68")	2	66"	30"	33"	16 1/2"	57"	124"	N/A	N/A	23"	4	16" D x 16" W
	138" (137.68")	2	69"	30"	34 1/2"	17 1/4"	57"	N/A	28"	65"	23"	8	16" D x 16" W
	144" (143.68")	2	72"	30"	36"	18"	57"	N/A	30"	68"	23"	8	16" D x 16" W
	150" (149.68")	2	75"	30"	37 1/2"	18 3/4"	57"	N/A	31"	71"	23"	8	16" D x 16" W
	156" (155.68")	2	78"	30"	39"	19 1/2"	57"	N/A	33"	73"	23"	8	16" D x 16" W
	162" (161.68")	2	81"	30"	40 1/2"	20 1/4"	57"	N/A	34"	75"	23"	8	16" D x 16" W
	168" (167.68")	2	84"	30"	42"	21"	57"	N/A	36"	78"	23"	8	16" D x 16" W
	174" (173.68")	2	87"	30"	43 1/2"	21 3/4"	57"	N/A	37"	81"	23"	8	16" D x 16" W

Product Details – Planes Perimeter Leg Conference Tables

Rectangular (Two-Piece Top)

Table Sizes and Seating Capacities– Without Cable Bases – Includes (10) Legs

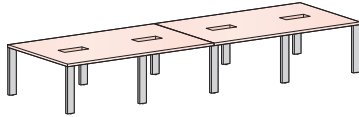

- 126" and 132" Wide Two-Piece Top Tables specified without a Cable Base are standard with 6 Legs.
- 138", 144", 150", 156", 162", 168", 174", 180" Wide Two-Piece Top Tables specified without a Cable Base are standard with 10 Legs.

		WIDTHS									
		126" Wide	132" Wide	138" Wide	144" Wide	150" Wide	156" Wide	162" Wide	168" Wide	174" Wide	180" Wide
DEPTHS	42" Deep										
	48" Deep										
	54" Deep										
	60" Deep										

Table Sizes and Seating Capacities – With Cable Bases – Includes (4) Legs

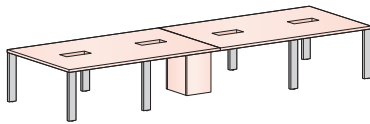

- 126" and 132" Wide Two-Piece Top Tables specified with a Cable Base are standard with 4 Legs.
- 138", 144", 150", 156", 162", 168", 174", 180" Wide Two-Piece Top Tables specified with a Cable Base are standard with 8 Legs.

		WIDTHS									
		126" Wide	132" Wide	138" Wide	144" Wide	150" Wide	156" Wide	162" Wide	168" Wide	174" Wide	180" Wide
DEPTHS	42" Deep										
	48" Deep										
	54" Deep										
	60" Deep										

Note Recommended seating capacity based upon a width of 27" per chair.

Product Details – Planes Perimeter Leg Conference Tables

Rectangular (Three-Piece Top)

Without Cable Base

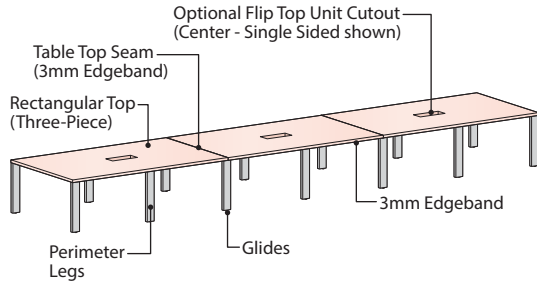

With Cable Base

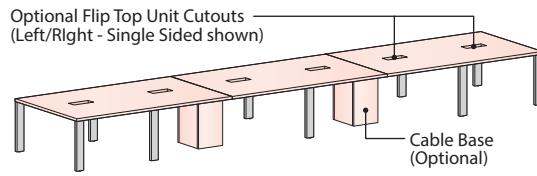

Component Materials/Finishes

COMPONENT NAME	MATERIALS/ FINISHES
Rectangle Top 3-Piece Top	Laminate Top – Specify separate finish colors for top and edge trim • Top is 2" thick. • Two-piece top is standard with 3mm laminate edgeband on user edges and 3mm edgeband on seam between tops.
	Wood Top – Specify a single finish color for the top and edge trim • Top is 2" thick. • Two-piece top is standard with 3mm wood edgeband on user edges and 3mm wood edgeband on seam between tops.
Interior Legs	Painted Metal – Specified Trim Color
Glides	Standard in Black
Cable Base (Optional)	Panels Laminate Panels – Specified surface and edge trim colors Wood Panels – Specified top and edge trim wood finish color
	Frame Painted Metal – Standard in Black

Flip Top Unit Cutout Options

Center Cutout Option

- Includes 3 Flip Top Unit cutouts (1 Cutout centered on each top piece)

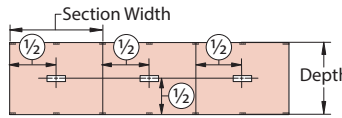

Left/Right Cutout Option

- Includes 6 Flip Top Unit cutouts (2 Cutouts on each top piece)

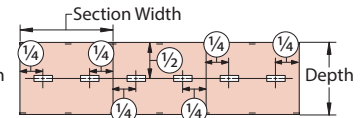

Cutout Option (F or V)

For use with Single Sided/
4 Port Flip Top Unit

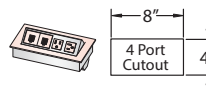

Cutout Option (J or K)

For use with Single Sided/
6 Ports Flip Top Unit

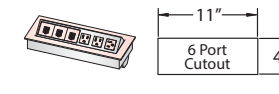

Cutout Option (M or P)

For use with Double Sided/
8 Ports Flip Top Unit

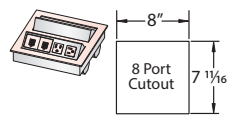

Cutout Option (Q or T)

For use with Double Sided/
12 Ports Flip Top Unit

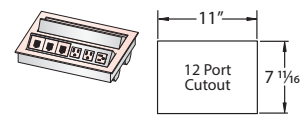

Note Flip Top Units are separately specified.

Cable Base Options

- Tables may be specified with or without Cable Bases
 - (Option N) No Cable Base.
 - (Option C) Includes (2) 14" x 14" Cable Bases

Three-Piece Table with Cable Base option (Top View)

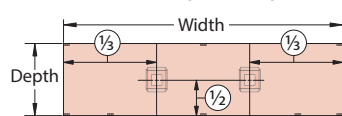

Cable Bases are centered on the seams between top pieces.

14" x 14" Cable Base

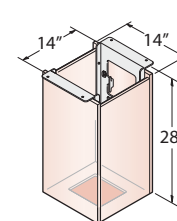

Product Details – Planes Perimeter Leg Conference Tables

Rectangular (Three-Piece Top)

Dimensions – 186"-198" Wide
Tables Without Cable Base
Includes (8) Legs

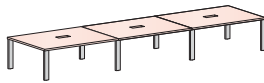

Top View

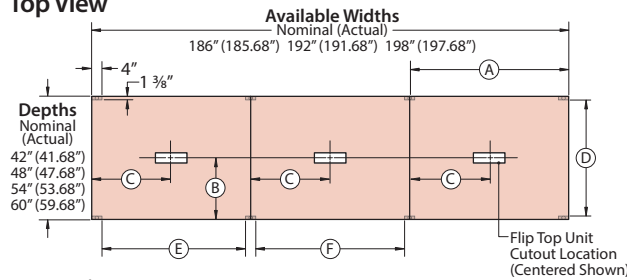

Front View

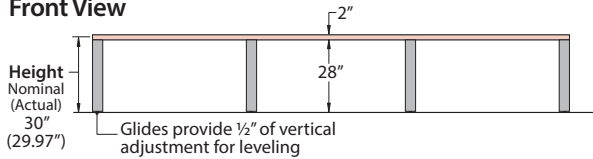

Dimensions – 204"-270" Wide
Tables Without Cable Base
Includes (14) Legs

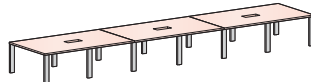

Top View

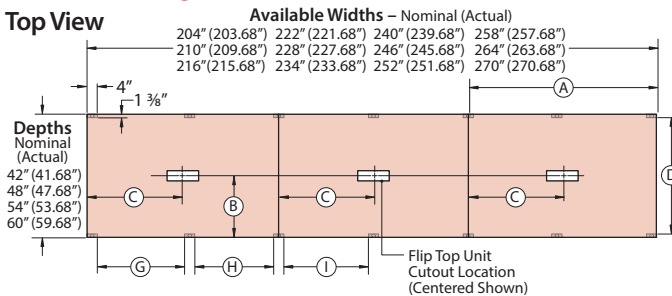

Front View

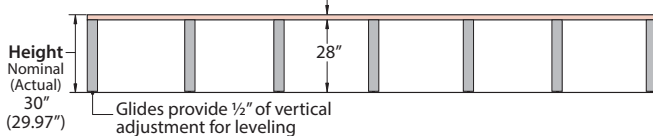

Dimensions

TABLETOP		KNEESPACE (Nominal)										
Depth Nominal (Actual)	Width Nominal (Actual)	# of Top Pieces	A	B	C	D	E	F	G	H	I	# of Legs Without Cable Base
42" (41.68")	186" (185.68")	3	62"	21"	31"	39"	56"	58"	N/A	N/A	N/A	8
	192" (191.68")	3	64"	21"	32"	39"	58"	60"	N/A	N/A	N/A	8
	198" (197.68")	3	66"	21"	33"	39"	60"	62"	N/A	N/A	N/A	8
	204" (203.68")	3	68"	21"	34"	39"	N/A	N/A	28"	30"	30"	14
	210" (209.68")	3	70"	21"	35"	39"	N/A	N/A	29"	31"	31"	14
	216" (215.68")	3	72"	21"	36"	39"	N/A	N/A	30"	32"	32"	14
	222" (221.68")	3	74"	21"	37"	39"	N/A	N/A	31"	33"	33"	14
	228" (227.68")	3	76"	21"	38"	39"	N/A	N/A	32"	34"	34"	14
	234" (233.68")	3	78"	21"	39"	39"	N/A	N/A	33"	35"	35"	14
	240" (239.68")	3	80"	21"	40"	39"	N/A	N/A	34"	36"	36"	14
	246" (245.68")	3	82"	21"	41"	39"	N/A	N/A	35"	37"	37"	14
	252" (251.68")	3	84"	21"	42"	39"	N/A	N/A	36"	38"	38"	14
	258" (257.68")	3	86"	21"	43"	39"	N/A	N/A	37"	39"	39"	14
	264" (263.68")	3	88"	21"	44"	39"	N/A	N/A	38"	40"	40"	14
270" (269.68")	3	90"	21"	45"	39"	N/A	N/A	39"	41"	41"	14	
48" (47.68")	186" (185.68")	3	62"	24"	31"	45"	56"	58"	N/A	N/A	N/A	8
	192" (191.68")	3	64"	24"	32"	45"	58"	60"	N/A	N/A	N/A	8
	198" (197.68")	3	66"	24"	33"	45"	60"	62"	N/A	N/A	N/A	8
	204" (203.68")	3	68"	24"	34"	45"	N/A	N/A	28"	30"	30"	14
	210" (209.68")	3	70"	24"	35"	45"	N/A	N/A	29"	31"	31"	14
	216" (215.68")	3	72"	24"	36"	45"	N/A	N/A	30"	32"	32"	14
	222" (221.68")	3	74"	24"	37"	45"	N/A	N/A	31"	33"	33"	14
	228" (227.68")	3	76"	24"	38"	45"	N/A	N/A	32"	34"	34"	14
	234" (233.68")	3	78"	24"	39"	45"	N/A	N/A	33"	35"	35"	14
	240" (239.68")	3	80"	24"	40"	45"	N/A	N/A	34"	36"	36"	14
	246" (245.68")	3	82"	24"	41"	45"	N/A	N/A	35"	37"	37"	14
	252" (251.68")	3	84"	24"	42"	45"	N/A	N/A	36"	38"	38"	14
	258" (257.68")	3	86"	24"	43"	45"	N/A	N/A	37"	39"	39"	14
	264" (263.68")	3	88"	24"	44"	45"	N/A	N/A	38"	40"	40"	14
270" (269.68")	3	90"	24"	45"	45"	N/A	N/A	39"	41"	41"	14	
54" (53.68")	186" (185.68")	3	62"	27"	31"	51"	56"	58"	N/A	N/A	N/A	8
	192" (191.68")	3	64"	27"	32"	51"	58"	60"	N/A	N/A	N/A	8
	198" (197.68")	3	66"	27"	33"	51"	60"	62"	N/A	N/A	N/A	8
	204" (203.68")	3	68"	27"	34"	51"	N/A	N/A	28"	30"	30"	14
	210" (209.68")	3	70"	27"	35"	51"	N/A	N/A	29"	31"	31"	14
	216" (215.68")	3	72"	27"	36"	51"	N/A	N/A	30"	32"	32"	14
	222" (221.68")	3	74"	27"	37"	51"	N/A	N/A	31"	33"	33"	14
	228" (227.68")	3	76"	27"	38"	51"	N/A	N/A	32"	34"	34"	14
	234" (233.68")	3	78"	27"	39"	51"	N/A	N/A	33"	35"	35"	14
	240" (239.68")	3	80"	27"	40"	51"	N/A	N/A	34"	36"	36"	14
	246" (245.68")	3	82"	27"	41"	51"	N/A	N/A	35"	37"	37"	14
	252" (251.68")	3	84"	27"	42"	51"	N/A	N/A	36"	38"	38"	14
	258" (257.68")	3	86"	27"	43"	51"	N/A	N/A	37"	39"	39"	14
	264" (263.68")	3	88"	27"	44"	51"	N/A	N/A	38"	40"	40"	14
270" (269.68")	3	90"	27"	45"	51"	N/A	N/A	39"	41"	41"	14	
60" (59.68")	186" (185.68")	3	62"	30"	31"	57"	56"	58"	N/A	N/A	N/A	8
	192" (191.68")	3	64"	30"	32"	57"	58"	60"	N/A	N/A	N/A	8
	198" (197.68")	3	66"	30"	33"	57"	60"	62"	N/A	N/A	N/A	8
	204" (203.68")	3	68"	30"	34"	57"	N/A	N/A	28"	30"	30"	14
	210" (209.68")	3	70"	30"	35"	57"	N/A	N/A	29"	31"	31"	14
	216" (215.68")	3	72"	30"	36"	57"	N/A	N/A	30"	32"	32"	14
	222" (221.68")	3	74"	30"	37"	57"	N/A	N/A	31"	33"	33"	14
	228" (227.68")	3	76"	30"	38"	57"	N/A	N/A	32"	34"	34"	14
	234" (233.68")	3	78"	30"	39"	57"	N/A	N/A	33"	35"	35"	14
	240" (239.68")	3	80"	30"	40"	57"	N/A	N/A	34"	36"	36"	14
	246" (245.68")	3	82"	30"	41"	57"	N/A	N/A	35"	37"	37"	14
	252" (251.68")	3	84"	30"	42"	57"	N/A	N/A	36"	38"	38"	14
	258" (257.68")	3	86"	30"	43"	57"	N/A	N/A	37"	39"	39"	14
	264" (263.68")	3	88"	30"	44"	57"	N/A	N/A	38"	40"	40"	14
270" (269.68")	3	90"	30"	45"	57"	N/A	N/A	39"	41"	41"	14	

Product Details – Planes Perimeter Leg Conference Tables

Rectangular (Three-Piece Top)

Dimensions – 186"-198" Wide
Tables Without Cable Base
Includes (6) Legs

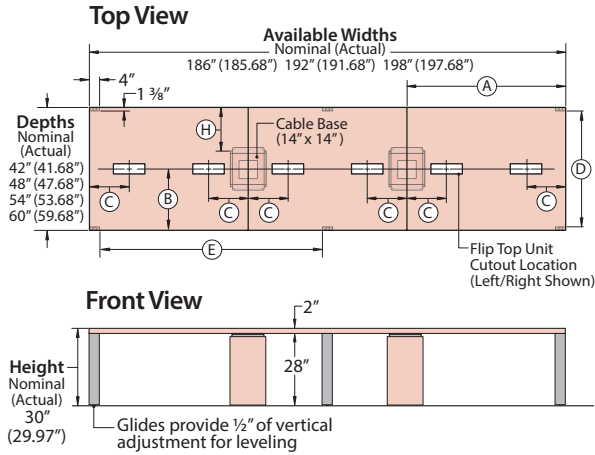
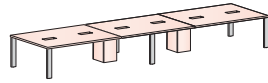

Dimensions – 204"-270" Wide
Tables Without Cable Base
Includes (10) Legs

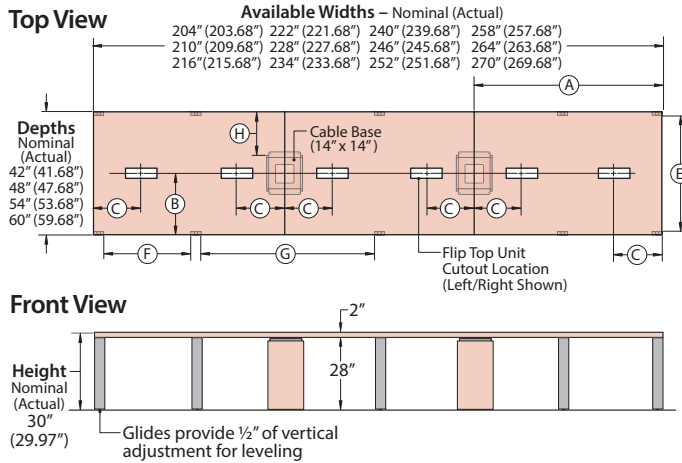
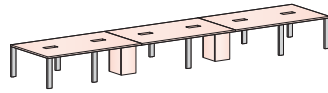

Dimensions

Depth Nominal (Actual)	TABLETOP			KNEESPACE (Nominal)								# of Legs With Cable Base
	Width Nominal (Actual)	# of Top Pieces		A	B	C	D	E	F	G	H	
42" (41.68")	186" (185.68")	3	62"	21"	15 1/2"	39"	87"	N/A	N/A	14"	6	
	192" (191.68")	3	64"	21"	16"	39"	90"	N/A	N/A	14"	6	
	198" (197.68")	3	66"	21"	16 1/2"	39"	93"	N/A	N/A	14"	6	
	204" (203.68")	3	68"	21"	17"	39"	N/A	28"	64"	14"	10	
	210" (209.68")	3	70"	21"	17 1/2"	39"	N/A	29"	66"	14"	10	
	216" (215.68")	3	72"	21"	18"	39"	N/A	30"	68"	14"	10	
	222" (221.68")	3	74"	21"	18 1/2"	39"	N/A	31"	70"	14"	10	
	228" (227.68")	3	76"	21"	19"	39"	N/A	32"	72"	14"	10	
	234" (233.68")	3	78"	21"	19 1/2"	39"	N/A	33"	74"	14"	10	
	240" (239.68")	3	80"	21"	20"	39"	N/A	34"	76"	14"	10	
	246" (245.68")	3	82"	21"	20 1/2"	39"	N/A	35"	78"	14"	10	
	252" (251.68")	3	84"	21"	21"	39"	N/A	36"	80"	14"	10	
	258" (257.68")	3	86"	21"	21 1/2"	39"	N/A	37"	82"	14"	10	
	264" (263.68")	3	88"	21"	22"	39"	N/A	38"	84"	14"	10	
270" (269.68")	3	90"	21"	22 1/2"	39"	N/A	39"	86"	14"	10		
48" (47.68")	186" (185.68")	3	62"	24"	15 1/2"	45"	87"	N/A	N/A	17"	6	
	192" (191.68")	3	64"	24"	16"	45"	90"	N/A	N/A	17"	6	
	198" (197.68")	3	66"	24"	16 1/2"	45"	93"	N/A	N/A	17"	6	
	204" (203.68")	3	68"	24"	17"	45"	N/A	28"	64"	17"	10	
	210" (209.68")	3	70"	24"	17 1/2"	45"	N/A	29"	66"	17"	10	
	216" (215.68")	3	72"	24"	18"	45"	N/A	30"	68"	17"	10	
	222" (221.68")	3	74"	24"	18 1/2"	45"	N/A	31"	70"	17"	10	
	228" (227.68")	3	76"	24"	19"	45"	N/A	32"	72"	17"	10	
	234" (233.68")	3	78"	24"	19 1/2"	45"	N/A	33"	74"	17"	10	
	240" (239.68")	3	80"	24"	20"	45"	N/A	34"	76"	17"	10	
	246" (245.68")	3	82"	24"	20 1/2"	45"	N/A	35"	78"	17"	10	
	252" (251.68")	3	84"	24"	21"	45"	N/A	36"	80"	17"	10	
	258" (257.68")	3	86"	24"	21 1/2"	45"	N/A	37"	82"	17"	10	
	264" (263.68")	3	88"	24"	22"	45"	N/A	38"	84"	17"	10	
270" (269.68")	3	90"	24"	22 1/2"	45"	N/A	39"	86"	17"	10		
54" (53.68")	186" (185.68")	3	62"	27"	15 1/2"	51"	87"	N/A	N/A	20"	6	
	192" (191.68")	3	64"	27"	16"	51"	90"	N/A	N/A	20"	6	
	198" (197.68")	3	66"	27"	16 1/2"	51"	93"	N/A	N/A	20"	6	
	204" (203.68")	3	68"	27"	17"	51"	N/A	28"	64"	20"	10	
	210" (209.68")	3	70"	27"	17 1/2"	51"	N/A	29"	66"	20"	10	
	216" (215.68")	3	72"	27"	18"	51"	N/A	30"	68"	20"	10	
	222" (221.68")	3	74"	27"	18 1/2"	51"	N/A	31"	70"	20"	10	
	228" (227.68")	3	76"	27"	19"	51"	N/A	32"	72"	20"	10	
	234" (233.68")	3	78"	27"	19 1/2"	51"	N/A	33"	74"	20"	10	
	240" (239.68")	3	80"	27"	20"	51"	N/A	34"	76"	20"	10	
	246" (245.68")	3	82"	27"	20 1/2"	51"	N/A	35"	78"	20"	10	
	252" (251.68")	3	84"	27"	21"	51"	N/A	36"	80"	20"	10	
	258" (257.68")	3	86"	27"	21 1/2"	51"	N/A	37"	82"	20"	10	
	264" (263.68")	3	88"	27"	22"	51"	N/A	38"	84"	20"	10	
270" (269.68")	3	90"	27"	22 1/2"	51"	N/A	39"	86"	20"	10		
60" (59.68")	186" (185.68")	3	62"	30"	15 1/2"	57"	87"	N/A	N/A	23"	6	
	192" (191.68")	3	64"	30"	16"	57"	90"	N/A	N/A	23"	6	
	198" (197.68")	3	66"	30"	16 1/2"	57"	93"	N/A	N/A	23"	6	
	204" (203.68")	3	68"	30"	17"	57"	N/A	28"	64"	23"	10	
	210" (209.68")	3	70"	30"	17 1/2"	57"	N/A	29"	66"	23"	10	
	216" (215.68")	3	72"	30"	18"	57"	N/A	30"	68"	23"	10	
	222" (221.68")	3	74"	30"	18 1/2"	57"	N/A	31"	70"	23"	10	
	228" (227.68")	3	76"	30"	19"	57"	N/A	32"	72"	23"	10	
	234" (233.68")	3	78"	30"	19 1/2"	57"	N/A	33"	74"	23"	10	
	240" (239.68")	3	80"	30"	20"	57"	N/A	34"	76"	23"	10	
	246" (245.68")	3	82"	30"	20 1/2"	57"	N/A	35"	78"	23"	10	
	252" (251.68")	3	84"	30"	21"	57"	N/A	36"	80"	23"	10	
	258" (257.68")	3	86"	30"	21 1/2"	57"	N/A	37"	82"	23"	10	
	264" (263.68")	3	88"	30"	22"	57"	N/A	38"	84"	23"	10	
270" (269.68")	3	90"	30"	22 1/2"	57"	N/A	39"	86"	23"	10		

Product Details – Planes Perimeter Leg Conference Tables

Rectangular (Three-Piece Top)

Table Sizes and Seating Capacities – Without Cable Bases

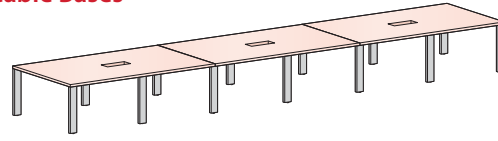
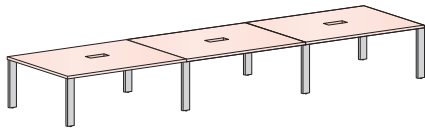

- 186", 192" and 198" Wide Three-Piece Top Tables specified without a Cable Base will include 6 Legs.
- 204", 210", 216", 222", 228", 234", 240", 246", 252", 258", 264" and 270" Wide Three-Piece Top Tables specified without a Cable Base will include 14 Legs.

		WIDTHS							
		186" Wide	192" Wide	198" Wide	204" Wide	210" Wide	216" Wide	222" Wide	228" Wide
DEPTHS	42" Deep								
	48" Deep	14 Chairs Maximum (8 Legs)	14 Chairs Maximum (8 Legs)	14 Chairs Maximum (8 Legs)	14 Chairs Maximum (14 Legs)	14 Chairs Maximum (14 Legs)	14 Chairs Maximum (14 Legs)	14 Chairs Maximum (14 Legs)	14 Chairs Maximum (14 Legs)
	54" Deep	14 Chairs Maximum (8 Legs)	14 Chairs Maximum (8 Legs)	14 Chairs Maximum (8 Legs)	14 Chairs Maximum (14 Legs)	14 Chairs Maximum (14 Legs)	14 Chairs Maximum (14 Legs)	14 Chairs Maximum (14 Legs)	14 Chairs Maximum (14 Legs)
	60" Deep	16 Chairs Maximum (8 Legs)	16 Chairs Maximum (8 Legs)	16 Chairs Maximum (8 Legs)	16 Chairs Maximum (14 Legs)	16 Chairs Maximum (14 Legs)	16 Chairs Maximum (14 Legs)	16 Chairs Maximum (14 Legs)	16 Chairs Maximum (14 Legs)

		WIDTHS						
		234" Wide	240" Wide	246" Wide	252" Wide	258" Wide	264" Wide	270" Wide
DEPTHS	42" Deep							
	48" Deep	14 Chairs Maximum (8 Legs)	14 Chairs Maximum (8 Legs)	14 Chairs Maximum (8 Legs)	14 Chairs Maximum (14 Legs)	14 Chairs Maximum (14 Legs)	14 Chairs Maximum (14 Legs)	14 Chairs Maximum (14 Legs)
	54" Deep	14 Chairs Maximum (8 Legs)	14 Chairs Maximum (8 Legs)	14 Chairs Maximum (8 Legs)	14 Chairs Maximum (14 Legs)	14 Chairs Maximum (14 Legs)	14 Chairs Maximum (14 Legs)	14 Chairs Maximum (14 Legs)
	60" Deep	16 Chairs Maximum (8 Legs)	16 Chairs Maximum (8 Legs)	16 Chairs Maximum (8 Legs)	16 Chairs Maximum (14 Legs)	16 Chairs Maximum (14 Legs)	16 Chairs Maximum (14 Legs)	16 Chairs Maximum (14 Legs)

Note Recommended seating capacity based upon a width of 27" per chair.

Product Details – Planes Perimeter Leg Conference Tables

Rectangular (Three-Piece Top)

Table Sizes and Seating Capacities – With Cable Bases

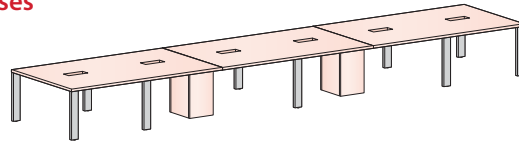
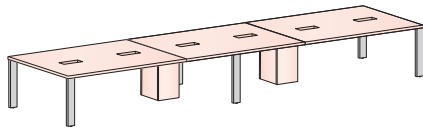

• 186", 192" and 198" Wide Three-Piece Top Tables specified with a Cable Base will include 2 Cable Bases and 6 Legs.

• 204", 210", 216", 222", 228", 234", 240", 246", 252", 258", 264" and 270" Wide Three-Piece Top Tables specified with a Cable Base will include 2 Cable Bases and 10 Legs.

		WIDTHS							
		186" Wide	192" Wide	198" Wide	204" Wide	210" Wide	216" Wide	222" Wide	228" Wide
DEPTHS	42" Deep								
	48" Deep								
	54" Deep								
	60" Deep								

		WIDTHS						
		234" Wide	240" Wide	246" Wide	252" Wide	258" Wide	264" Wide	270" Wide
DEPTHS	42" Deep							
	48" Deep							
	54" Deep							
	60" Deep							

Note Recommended seating capacity based upon a width of 27" per chair.

Product Details – Planes Conference Tables

Power Components – Flip Top Units

- Separately specified Flip Top Units are designed to be field installed into tables specified with factory cutouts (Tables must be specified with the appropriate cutouts).
- Spring release cover provides two positions; closed or fully open.
- The bezel and spring release cover are proud to table top.
- When installed into a 1 3/16" top, the Flip Top Unit will extend below the top 2 3/4"
- Flip Top Units are available with the following port options (See price list for available configurations):
 - Power Port (Simplex Outlet - NEMA5-15P)
 - USB Charging Port (with two outlets)
 - Data Port (for use with Data Jack Adapters)
 - Cable Bay (Accommodates two pull-out data/AV cables - field supplied)

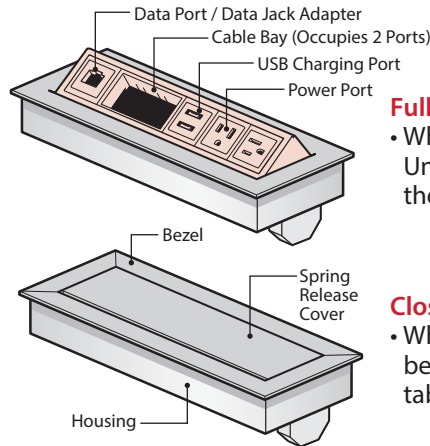

- Fully Open Position**
- When open the Flip Top Unit projects 1" above the table top.
- Closed Position**
- When closed the flip top bezel is proud to the table top.

4-Port – Single Sided
(Shown with Corded)

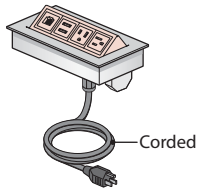

4-Port – Double Sided
(Shown with Hardwire)

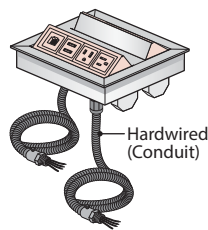

6-Port – Single Sided
(Shown with Hardwire)

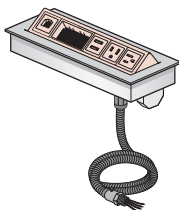

6-Port – Double Sided
(Shown with Corded)

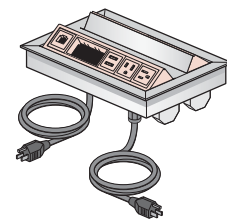

Component Materials/Finishes

COMPONENT NAME	MATERIALS/ FINISHES
Bezel/Housing/Spring Release Cover – Ports (Power/USB/Cable Bays/Data)	• Bezel/Spring Release Cover – Clear Anodized Aluminum
	• Ports (Power/USB/Cable Bays/Data) – White Plastic
Power Connectors	• Bezel/Spring Release Cover – Black Anodized Aluminum
	• Ports (Power/USB/Cable Bays/Data) – Black Plastic
Cord with Plug	6' or 12' Long – standard in black.
	Hardwired

Corded Plugs

- Corded Flip Top Units with 3 or less Power/USB Charging ports includes a standard plug (NEMA5-15P).
- Corded Flip Top Units with four or more Power or USB Charging Ports includes a fused plug that may block adjacent building receptacle outlets.

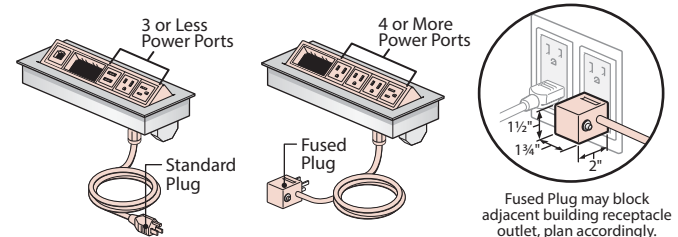

Dimensions

Side View – Single Sided

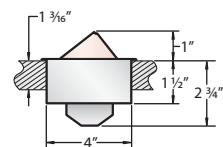

Top View – 4-Port/Single-Sided

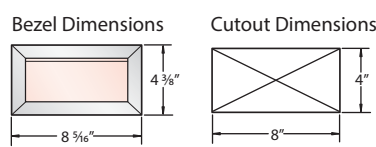

Top View – 6-Port/Single-Sided

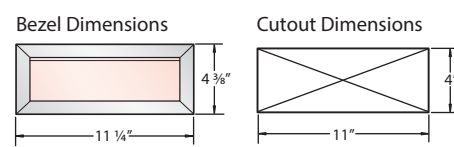

Side View – Double Sided

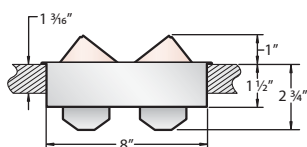

Top View – 4-Port/Double-Sided

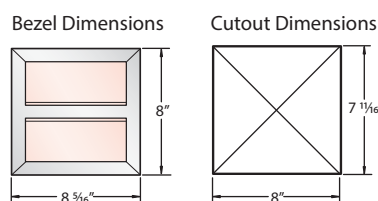

Top View – 6-Port/Double-Sided

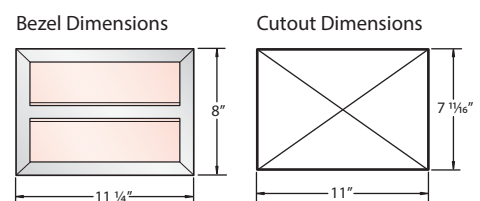

- Flip Top Units are field installed into a factory cutouts (Specify appropriate cutouts when ordering the table).
- Corded Flip Top Unit applications should be reviewed by local authorities (electrical inspector) prior to ordering this product.
- For use with 120 volt 60 hertz power source only.

Note

Configuration and quantity of power and data ports can not be modified in the field.

Product Details – Planes Conference Tables

Cable Management – Cable Bases

- Cable Bases are designed for power and data cable management and are an available option with most Interior Leg Conference Tables.
- Cable Bases are available in two sizes to accommodate different table depths.
 - 36" deep tables specified with Cable Bases includes an 8" x 14" Cable Base.
 - 42" deep and deeper tables specified with a cable base includes a 14" x 14" Cable Base.
- Cable Bases are not recommended for the following tables due to lack of kneespace clearance (Consider a separately specified Cable Column for cable management with these tables):
 - 30" Deep Tables
 - Half Round Tables
 - One-Piece Round Tables
 - Polygon Tables
 - One-Piece Square Tables
- Each Cable Base includes a cutout on the bottom of the base for routing wires and two removable side panels for access to the interior compartment.
- In addition to providing power and data cable management, the Cable Base can also provide table floor support. Depending on the shape and size of the table, it may be used in place of Interior Legs reducing the overall number of legs
- The surface and edge colors of the Cable Base are a separate specification from the table top finish.
- The Cable Base may also be ordered separately as a field installed accessory
- Cable Base locations are predetermined for support and load purposes. If the Cable Base is ordered as an option, tables are pre-drilled for field installation of legs and the Cable Base. If the Cable Base is ordered as an accessory, it must be installed according to installation instructions and field drilling is required. Refer to installation instructions for leg removal or relocation guidelines.

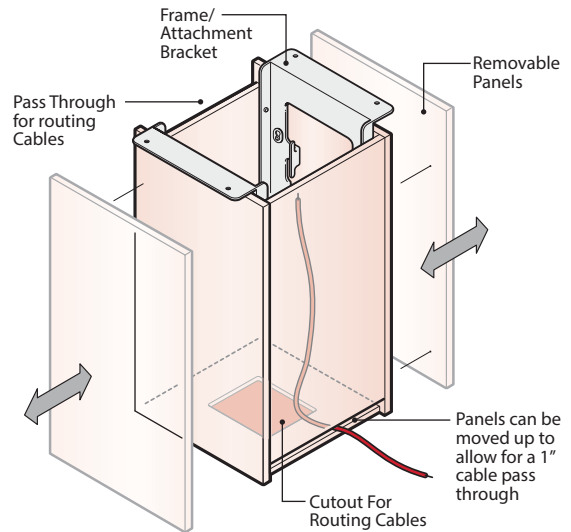

14" x 14" Cable Base – (42" Deep or Deeper Tables only)

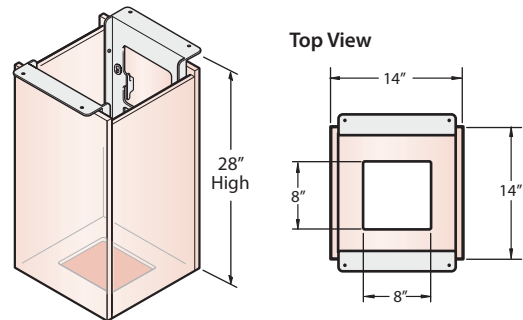

8" x 14" Cable Base – (36" Deep Tables only)

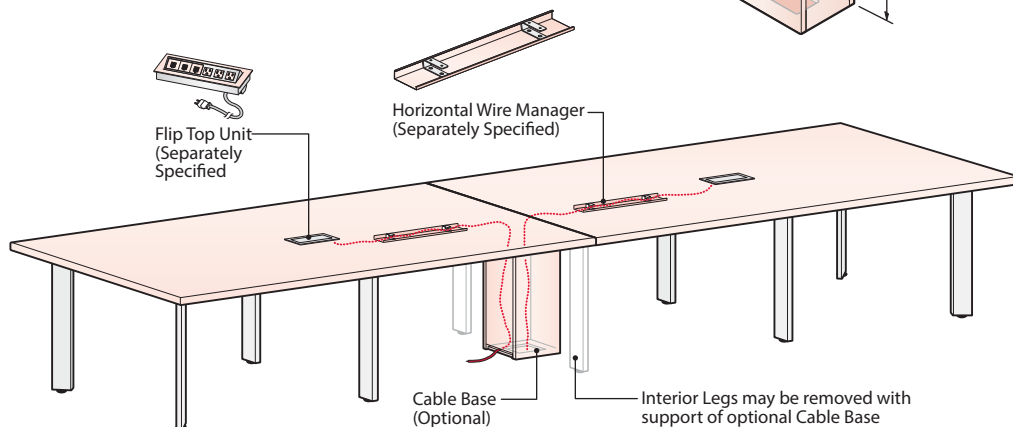
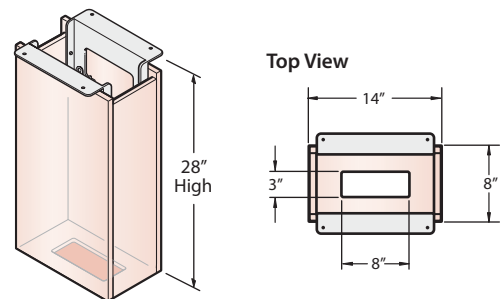

Typical Table Application with Cable Base for Wire Management

- Separately specified Flip Top Unit cables drop below the table top and can be routed via a separately specified Horizontal Wire Manager, then routed through the optional Cable Base to the building power.

Product Details – Planes Conference Tables

Cable Management – Cable Column

The Planes Cable Column provides an alternative solution to the Cable Base for vertically managing cables from beneath a Planes table to the floor. The Cable Column is ideal for tables when a Cable Base cannot be used.

- Cable Column is non-load bearing and does not replace table leg(s).
- Cable Column can be installed anywhere under a conference table unless it would interfere with table legs, Horizontal Wire Manager, or Flip Top Power/ Data Units.
- Includes one Cable Column with mounting hardware for attaching to table underside.
- Does not include hardware for attaching Cable Column to floor; field supplied.
- Floor Mount Bracket is recessed into the Cable Column with a 1" height adjustable range. When Floor Mount Bracket is fully extended the overall Cable Column height is 29" H.

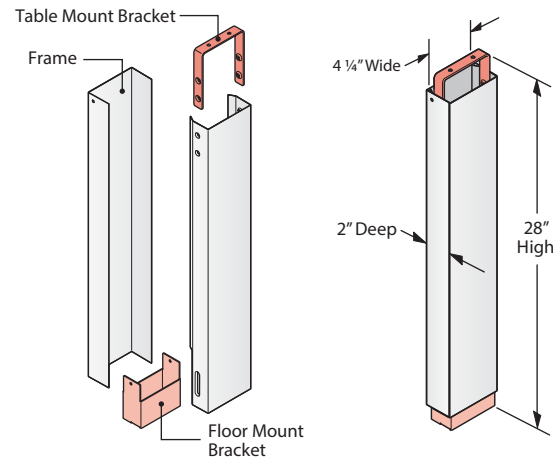

Common Cable Column Applications

The Cable Column is always attached beneath the table top and anchored to the building. Accessing the building power supply through the Cable Column can be done in two ways.

Application A

Cables exit the Cable Column directly through the bottom of the floor mount bracket. The bottom of the floor mount bracket is open.

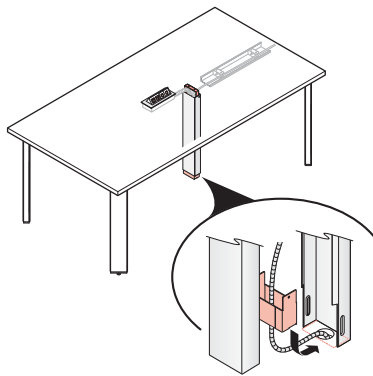

Application B

Cables exit the Cable Column through the side of the floor mount bracket. The tab located on the bracket must be field removed, resulting in a 1" H opening. The Floor Mount Bracket can be field cut, resulting in a 2.25" H opening.

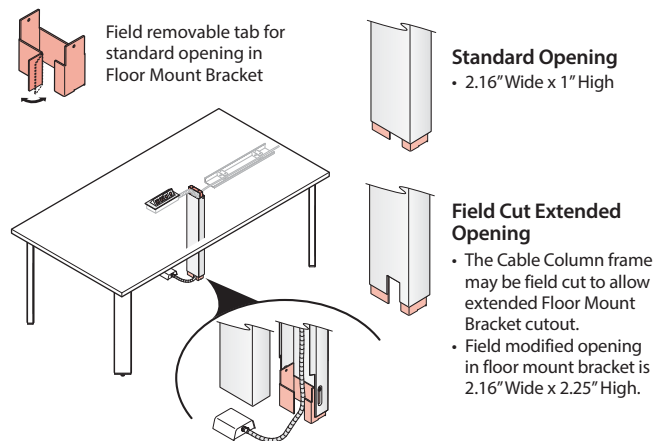

Cable Column Fill Capacity

- This chart shows the number of communication cables that can be routed through specific pathways.
- Cable capacities are based on 0.20" (5mm), 0.25" (6mm), and 0.30" (8mm) diameter cables at 60% and 40% fill capacity.
- TIA/EIA 569 suggests a cable fill of 40% for planning and up to 60% for unplanned or future additions.
- The TIA category designations for cable are not size specific but typically the higher the category number the larger the diameter the cable is.
- As a general rule a Category 5e (Enhanced) cable is approximately 0.20" in diameter, the Category 6 0.25", and a Category 6A (Augmented) 0.30". The actual diameter will vary depending on manufacturer and whether it is a plenum rated cable or riser (PVC) cable.

CABLE PATHWAY	OPENING SIZE	CABLE CAPACITY 60% FILL*			CABLE CAPACITY 40% FILL* (Cable Gauge)		
		0.20"	0.25"	0.30"	0.20"	0.25"	0.30"
Application A Routing Through Base of Floor Mount Bracket	4.95 Square Inches	94	60	42	63	40	28
Application B Routing Through Standard Opening In Floor Mount Bracket	2.17 Square Inches	41	26	18	27	17	12
Application B Routing Through Field Cut Extended Opening In Floor Mount Bracket	5.04 Square Inches	96	61	42	64	41	28

Product Details – Planes Conference Tables

Cable Management – Horizontal Wire Manager

- Recommended for use with the Flip Top Units to route power and data cabling horizontally under the tabletop.
- The cables beneath the Flip Top Unit are routed through the Horizontal Wire Manager to the Cable Base and down to the building power that is located in the floor.
- The plastic Wire Manager can be cut to length in the field to accommodate a variety of applications.
- The Wire Manager snaps over Attachment Clips to attach the unit to the underside of the table. Attachment Clips should not be spaced more than 24" apart.
- The Horizontal Wire Manager is a handed component; the cables can exit from the lower side or either end, depending on application.

Note For field cut applications, refer to chart to determine if additional attachment clips are needed.

Tip Horizontal Wire Manager is not for use with Y-Leg Tables. A trough runs between the two Y-Legs in the base of all Y-Leg tables for lay-in cable management.

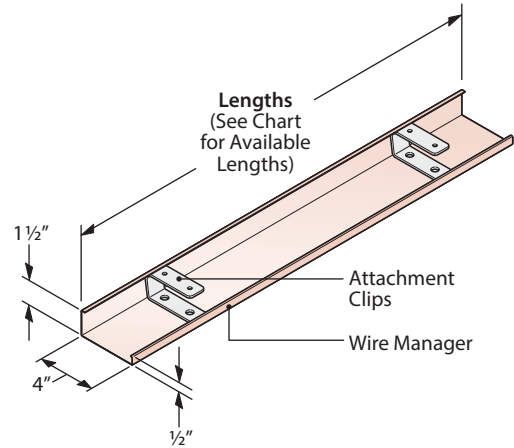

Component Materials/Finishes

COMPONENT NAME	MATERIALS/ FINISHES
Wire Manager	Plastic – Standard in Light Platinum
Attachment Clip	Metal – Standard in Black

Common Horizontal Wire Manager Applications

Adjacent to Cable Base

- Horizontal Wire Manager is mounted adjacent to the Cable Base to route cables from the Flip Top Unit.

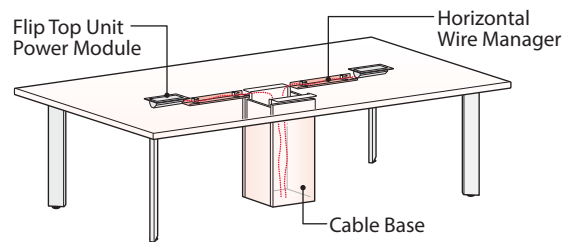

Cable Base Pass Through

- Horizontal Wire Manager passes through the Cable Base to route cables from the Flip Top Unit.

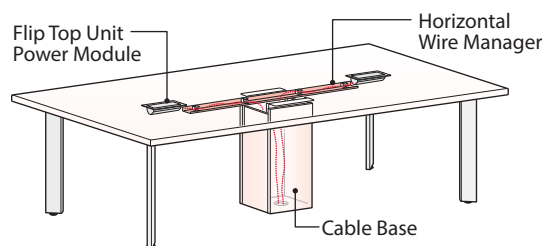

Lengths and Attachment Clip Numbers

HORIZONTAL WIRE MANAGER	
LENGTH	Included Number of Attachment Clips
48"	2 Clips
72"	3 Clips
96"	3 Clips
120"	4 Clips

Horizontal Wire Manager Fill Capacity

- This chart shows the number of communication cables that can be routed through specific pathways.
- Cable capacities are based on 0.20" (5mm), 0.25" (6mm), and 0.30" (8mm) diameter cables at 60% and 40% fill capacity.
- TIA/EIA 569 suggests a cable fill of 40% for planning and up to 60% for unplanned or future additions.
- The TIA category designations for cable are not size specific but typically the higher the category number the larger the diameter the cable is.
- As a general rule a Category 5e (Enhanced) cable is approximately 0.20" in diameter, the Category 6 0.25", and a Category 6A (Augmented) 0.30". The actual diameter will vary depending on manufacturer and whether it is a plenum rated cable or riser (PVC) cable.

CABLE PATHWAY	OPENING SIZE	CABLE CAPACITY 60% FILL* (Cable Gauge)			CABLE CAPACITY 40% FILL* (Cable Gauge)		
		0.20"	0.25"	0.30"	0.20"	0.25"	0.30"
Routing cables through the end of the Wire Manager	2 Square Inches	38	24	17	25	16	11

Product Details – Planes Conference Tables

Cable Management – Horizontal Wire Manager – Planning Guidelines

- The Horizontal Wire Manager may be cut shorter or extend past the distance being spanned.
- All routing methods require field drilling for the attachment clips.
- The Horizontal Wire Manager should not be mounted under the Flip Top Units as it could interfere with operation of the flip top mechanism.

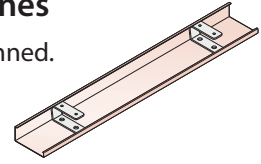

Adjacent To Cable Base Application

- Horizontal Wire Manager is mounted next to the Cable Base, with the lower side of the Horizontal Wire Manager positioned toward the Flip Top Unit.

Adjacent to Cable Base Planning Example:

- One-Piece Table (120" wide) with 14" x 14" Cable Base and Center Flip Top Unit Cutouts.
- Specify (1) 48" Horizontal Wire Manager (cut to fit).

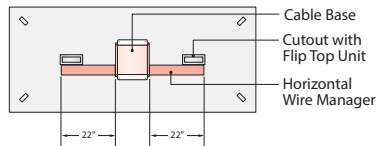

Adjacent to Cable Base Planning Example:

- Two-Piece Table (150" Wide) with 14" x 14" Cable Base and Center Flip Top Unit Cutouts.
- Specify (1) 72" Horizontal Wire Manager (cut to fit).

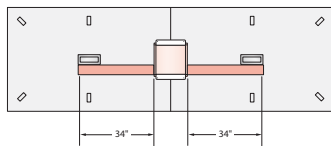

Adjacent to Cable Base Planning Example:

- Two-Piece Table (150" Wide) with 14" x 14" Cable Base and Left/Right Flip Top Unit Cutouts.
- Specify (2) 48" Horizontal Wire Manager (cut to fit).

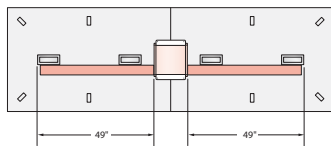

Adjacent to Cable Base Planning Example:

- Three-Piece Table (222" Wide) with 14" x 14" Cable Base and Center Flip Top Unit Cutouts.
- Specify (2) 72" Horizontal Wire Managers (cut to fit).

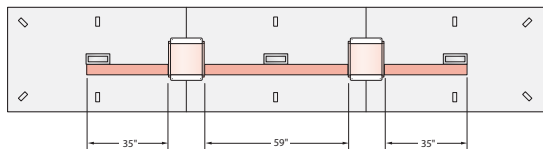

Adjacent to Cable Base Planning Example:

- Three-Piece Table (222" Wide) with 14" x 14" Cable Base and Left/Right Flip Top Unit Cutouts.
- Specify (1) 72" and (2) 48" Horizontal Wire Managers (cut to fit).

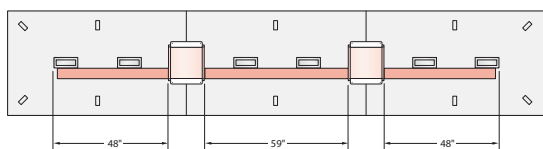

Cable Base Pass Through Application

- Horizontal Wire Manager is mounted between the Flip Top Units and passes through the top opening of the Cable Base.
- This application cannot be used if the side panels of the Cable Base are raised to utilize the 1" pass through at the bottom.

Cable Base Pass Through Planning Example:

- One-Piece Table (120" wide) with 14" x 14" Cable Base and Center Flip Top Unit Cutouts.
- Specify (1) 48" Horizontal Wire Manager (cut to fit).

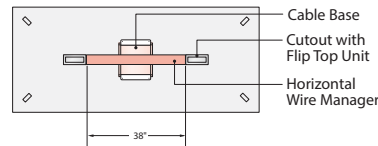

Cable Base Pass Through Planning Example:

- Two-Piece Table (150" Wide) with 14" x 14" Cable Base and Center Flip Top Unit Cutouts.
- Specify (1) 72" Horizontal Wire Manager (cut to fit).

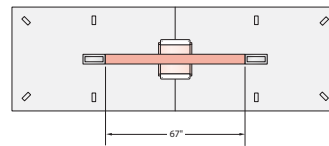

Cable Base Pass Through Planning Example:

- Two-Piece Table (150" Wide) with 14" x 14" Cable Base and Left/Right Flip Top Unit Cutouts.
- Specify (1) 72" Horizontal Wire Managers (cut to fit).

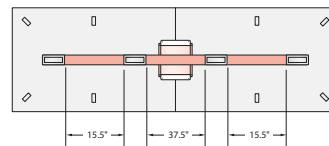

Cable Base Pass Through Planning Example:

- Three-Piece Table (222" Wide) with 14" x 14" Cable Base and Center Flip Top Unit Cutouts.
- Specify (2) 72" Horizontal Wire Managers (cut to fit).

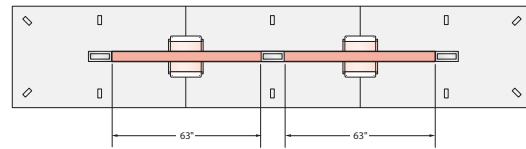

Cable Base Pass Through Planning Example:

- Three-Piece Table (222" Wide) with 14" x 14" Cable Base and Left/Right Flip Top Unit Cutouts.
- Specify (1) 72" and (1) 48" Horizontal Wire Managers (cut to fit).

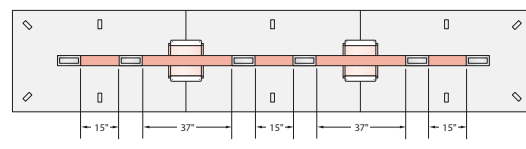

Product Details – Planes Conference Table Top (for use with Column Base)

Overview

The Conference Top with Cable Column fits the needs of any conference room or conferencing style. First select a top from wide variety of table top sizes and shapes, next combine it with a column base assembly to support the top in a range of heights. The rectilinear design, along with the sleek open profile, give this conference table a clean, contemporary aesthetic.

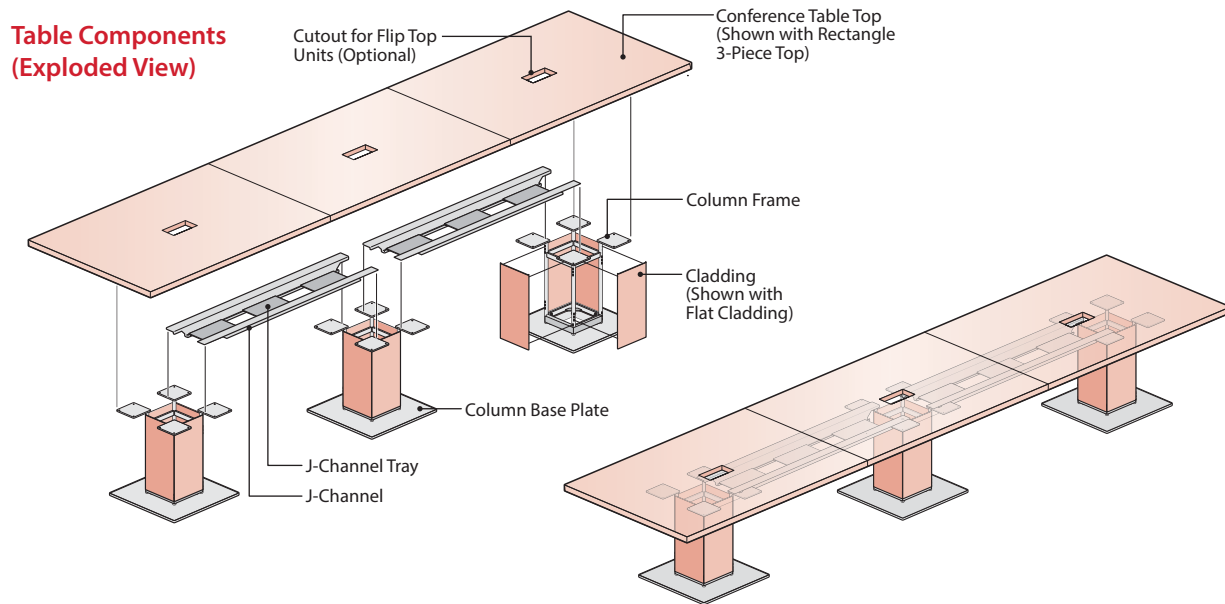

Steps to Specifying a Conference Table with Cable Base

Step 1 | Conference Top

- The number of tops depend on the width of the conference table.
- Top options include a 1-piece top, 2-piece top or 3-piece top.

Step 2 | Column Base Assembly

- Each Column Base requires separately specified components: Column Frame, Column Base Plate, and Cladding.

A. Column Frame

- Column Frames are square and are available in two sizes, 9" and 12" square, and three heights, 20" lounge height , 28" seated height and 40" standing height.
 - The table top width and the number of pieces dictate the quantity of column frame(s).
 - The table top depth dictates the column frame size, 9" or 12" square.

B. Column Base Plate

- Round or Square Column Base Plates are available in four sizes: 21", 24", 27" and 30".
- The column base plate size is specific to the column frame size of 9" or 12"; specify accordingly.
- The column frame width and the table top depth dictate the size of the column base plate.

C. Cladding

- Round or Flat Cladding is available in two widths, 9" & 12", and three heights, 20" lounge height, 28" seated height and 40" standing height. (Exception: Round cladding is not available 40" high)
 - Cladding is specified as one single piece per catalog number. A quantity of (4) pieces are required per each Column Frame. Note: All round or flat, or a combination of round and flat cladding may be used on a column frame.
 - Specify cladding to match the column frame width and height.

D. J-Channel

- Provides wire management and the required support below the Conference Table Top.
 - J-Channel is specified as one pair per catalog number. A pair of J-Channels are used between each column base.
 - The table top width and column size dictate the number of pairs and length of J-Channel.

E. J-Channel Tray (Optional)

- J-Channel Trays are optional and provide additional wire management between columns; lays in J-Channels.
 - Specify J-Channel Tray width to match Column Frame size.
 - The J-Channel length dictates the maximum number of J-Channel Trays.

Product Details – Planes Conference Table Top (for use with Column Base)

Overview

Edge Details for Laminate Conference Table Tops

3mm Edgeband Edge (Option J)

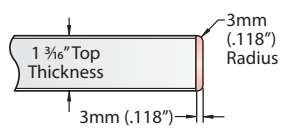

Top View Detail

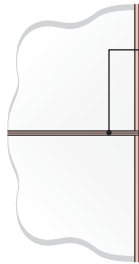

Seams with Multiple Piece Top have 1mm Edgeband

Knife Edge (Option F)

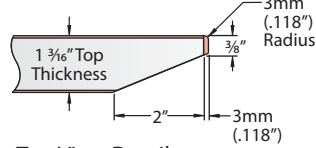

Top View Detail



Seams with Multiple Piece Top have 1mm Edgeband

Edge Details for Wood Conference Table Tops

3mm Edgeband Edge (Option K)

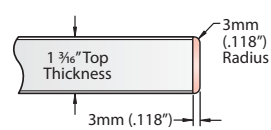

Top View Detail



Seams with Multiple Piece Top have 1mm Edgeband

Knife Edge (Option U)

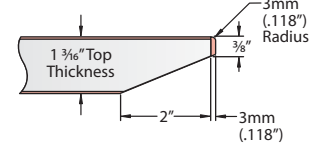

Top View Detail



Seams with Multiple Piece Top have 1mm Edgeband

- Note**
- Refer to Price List for edge availability.
 - Specified Edgeband option is applied to all outside edges of the top.
 - Multiple piece tops with Cascade edge option will require an additional specification for the 1mm edgeband seam.

Product Details – Planes Conference Table Top (for use with Column Base)

Round, Square and Pebble Tops

Round

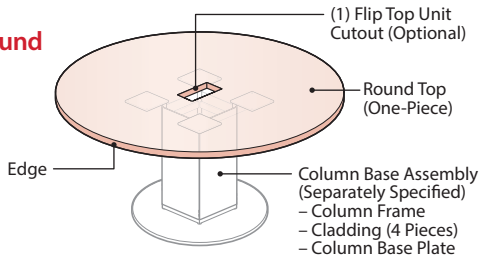

Square

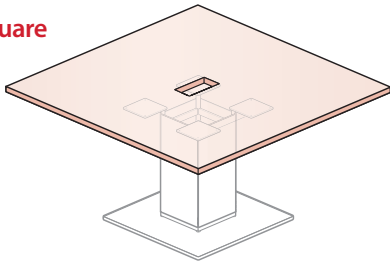

Pebble

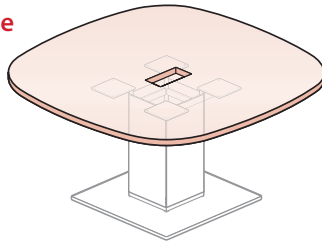

Component Materials/Finishes

COMPONENT NAME	MATERIALS/ FINISHES
Round, Square and Pebble 1-Piece Top	Laminate Top – Specified top color and specified edge trim color • Edge Options: (J) Edgeband, (F) Knife
	Wood Top – Specified top and edge trim wood finish color • Edge Options: (K) Edgeband, (U) Knife

Edge Options for Laminate Tops

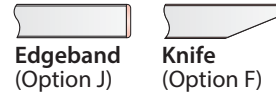

Edge Options for Wood Tops



Flip Top Unit Cutout Options

Cutout Location – Center Cutout Option

- Includes 1 Flip Top Unit cutout (centered on top)

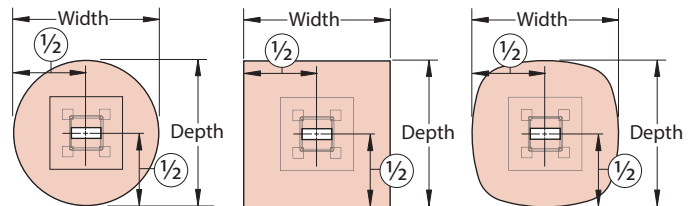

Center Cutout Options

- Includes 1 Flip Top Unit cutout (centered on top)
- Cutouts require separately specified Flip Top Unit.

Cutout Option (F)

For use with Single Sided/ 4 Port Flip Top Unit

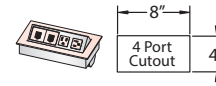

Cutout Option (J)

For use with Single Sided/ 6 Ports Flip Top Unit

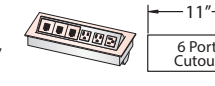

Cutout Option (M)

For use with Double Sided/ 8 Ports Flip Top Unit

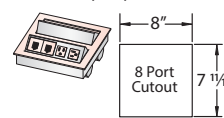

Cutout Option (Q)

For use with Double Sided/ 12 Ports Flip Top Unit

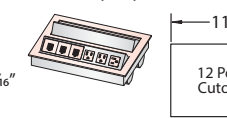

Note Double-Sided Flip Top Units cannot be placed over the 9" x 9" Column Frame.

Separately Specified Components

- One Piece Round, Square and Pebble Tops requires a separately specified Column Base.
- A Column Base is comprised of a separately specified Column Frame, Column Base Plate and Cladding.
- Column Frames are available with 20", 28" and 40" heights.

Cable Column Heights

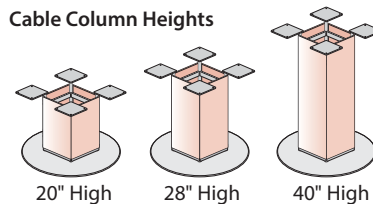

Note See the Floor Support Requirements – Specification Matrix, for Column Frames and Column Base Plates specification requirements.

Product Details – Planes Conference Table Top (for use with Column Base)

Round, Square and Pebble Tops – Dimensions

Dimensions

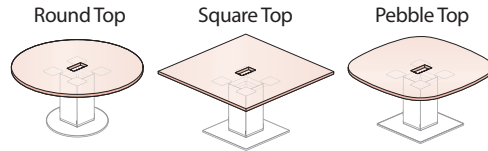
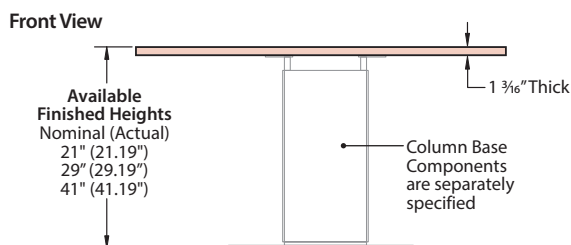
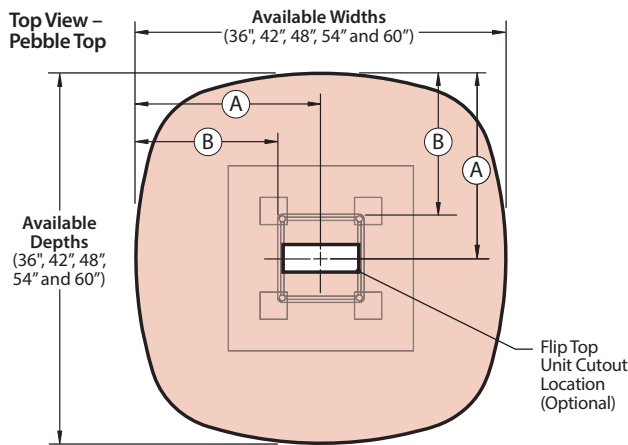
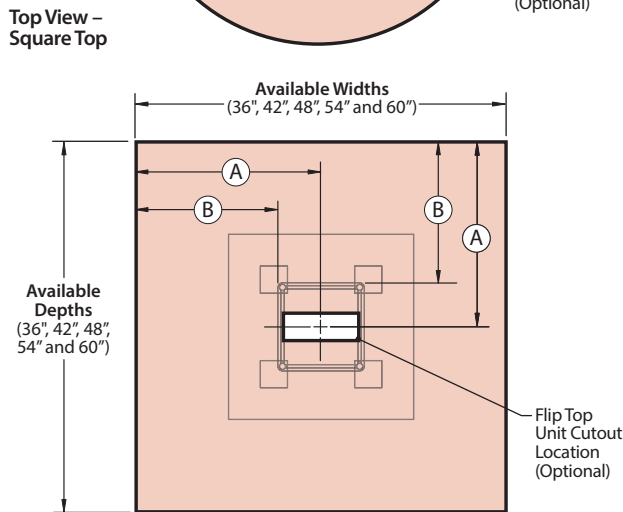
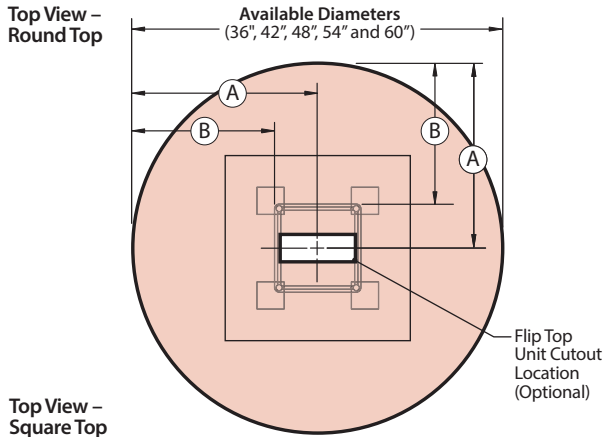

Dimensions

TABLETOP			KNEESPACE			
Width Nominal (Actual)	Depth Nominal (Actual)	A	B			
			With 9" x 9" Column Frame		With 12" x 12" Column Frame	
			Flat Cladding	Round Cladding	Flat Cladding	Round Cladding
36" (35.68")	36" (35.68")	18"	13"	11 1/4"	11 1/2"	9 1/8"
42" (41.68")	42" (41.68")	21"	16"	14 1/4"	14 1/2"	12 1/8"
48" (47.68")	48" (47.68")	24"	N/A	N/A	17 1/2"	15 1/8"
54" (53.68")	54" (53.68")	27"	N/A	N/A	20 1/2"	18 1/8"
60" (59.68")	60" (59.68")	30"	N/A	N/A	23 1/2"	21 1/8"

Table Top Sizes and Seating Capacities

Round Top

DIAMETER				
36" Diameter	42" Diameter	48" Diameter	54" Diameter	60" Diameter
4 Chairs Maximum (1 Cable Column)	4 Chairs Maximum (1 Cable Column)	5 Chairs Maximum (1 Cable Column)	6 Chairs Maximum (1 Cable Column)	7 Chairs Maximum (1 Cable Column)

Square Top

TOP SIZES – WIDTH x DEPTH				
36" W x 36" D	42" W x 42" D	48" W x 48" D	54" W x 54" D	60" W x 60" D
4 Chairs Maximum (1 Column Base)	4 Chairs Maximum (1 Column Base)	4 Chairs Maximum (1 Column Base)	6 Chairs Maximum (1 Column Base)	8 Chairs Maximum (1 Column Base)

Pebble Top

TOP SIZES – WIDTH x DEPTH				
36" W x 36" D	42" W x 42" D	48" W x 48" D	54" W x 54" D	60" W x 60" D
4 Chairs Maximum (1 Column Base)	4 Chairs Maximum (1 Column Base)	4 Chairs Maximum (1 Column Base)	6 Chairs Maximum (1 Column Base)	8 Chairs Maximum (1 Column Base)

Note Recommended seating capacity based upon a width of 27" per chair.

Product Details – Planes Conference Table Top (for use with Column Base)

Round, Square and Pebble Tops – Floor Support Requirements

Round Top / Column Frame with Round Base Plate

ROUND TOP SIZES	COLUMN FRAME/BASE PLATE COMBINATIONS				
	9" x 9" Column Frame		12" x 12" Column Frame		
	21" Round Base Plate	24" Round Base Plate	24" Round Base Plate	27" Round Base Plate	30" Round Base Plate
36" Diameter Top					
42" Diameter Top	⊗ Don't				
48" Diameter Top	⊗ Don't	⊗ Don't	⊗ Don't		
54" Diameter Top	⊗ Don't	⊗ Don't	⊗ Don't	⊗ Don't	
60" Diameter Top	⊗ Don't	⊗ Don't	⊗ Don't	⊗ Don't	

Round Top / Column Frame with Square Base Plate

ROUND TOP SIZES	COLUMN FRAME/BASE PLATE COMBINATIONS				
	9" x 9" Column Frame		12" x 12" Column Frame		
	21" Square Base Plate	24" Square Base Plate	24" Square Base Plate	27" Square Base Plate	30" Square Base Plate
36" Diameter Top				⊗ Don't	⊗ Don't
42" Diameter Top	⊗ Don't				
48" Diameter Top	⊗ Don't	⊗ Don't	⊗ Don't		
54" Diameter Top	⊗ Don't	⊗ Don't	⊗ Don't		
60" Diameter Top	⊗ Don't	⊗ Don't	⊗ Don't		

Square Top / Column Frame with Round Base Plate

SQUARE TOP SIZES	COLUMN FRAME/BASE PLATE COMBINATIONS				
	9" x 9" Column Frame		12" x 12" Column Frame		
	21" Round Base Plate	24" Round Base Plate	24" Round Base Plate	27" Round Base Plate	30" Round Base Plate
36" Wide x 36" Deep					
42" Wide x 42" Deep	⊗ Don't				
48" Wide x 48" Deep	⊗ Don't	⊗ Don't	⊗ Don't		
54" Wide x 54" Deep	⊗ Don't	⊗ Don't	⊗ Don't	⊗ Don't	
60" Wide x 60" Deep	⊗ Don't	⊗ Don't	⊗ Don't	⊗ Don't	

Square Top / Column Frame with Square Base Plate

SQUARE TOP SIZES	COLUMN FRAME/BASE PLATE COMBINATIONS				
	9" x 9" Column Frame		12" x 12" Column Frame		
	21" Square Base Plate	24" Square Base Plate	24" Square Base Plate	27" Square Base Plate	30" Square Base Plate
36" Wide x 36" Deep					
42" Wide x 42" Deep	⊗ Don't				
48" Wide x 48" Deep	⊗ Don't	⊗ Don't	⊗ Don't		
54" Wide x 54" Deep	⊗ Don't	⊗ Don't	⊗ Don't		
60" Wide x 60" Deep	⊗ Don't	⊗ Don't	⊗ Don't		

Pebble Top / Column Frame with Round Base Plate

PEBBLE TOP SIZES	COLUMN FRAME/BASE PLATE COMBINATIONS				
	9" x 9" Column Frame		12" x 12" Column Frame		
	21" Round Base Plate	24" Round Base Plate	24" Round Base Plate	27" Round Base Plate	30" Round Base Plate
36" Wide x 36" Deep					
42" Wide x 42" Deep	⊗ Don't				
48" Wide x 48" Deep	⊗ Don't	⊗ Don't	⊗ Don't		
54" Wide x 54" Deep	⊗ Don't	⊗ Don't	⊗ Don't	⊗ Don't	
60" Wide x 60" Deep	⊗ Don't	⊗ Don't	⊗ Don't	⊗ Don't	

Pebble Top / Column Frame with Square Base Plate

PEBBLE TOP SIZES	COLUMN FRAME/BASE PLATE COMBINATIONS				
	9" x 9" Column Frame		12" x 12" Column Frame		
	21" Square Base Plate	24" Square Base Plate	24" Square Base Plate	27" Square Base Plate	30" Square Base Plate
36" Wide x 36" Deep					⊗ Don't
42" Wide x 42" Deep	⊗ Don't				
48" Wide x 48" Deep	⊗ Don't	⊗ Don't	⊗ Don't		
54" Wide x 54" Deep	⊗ Don't	⊗ Don't	⊗ Don't		
60" Wide x 60" Deep	⊗ Don't	⊗ Don't	⊗ Don't		

Note • Double-Sided Flip Top Units cannot be placed over the 9" x 9" Column Frames.

Product Details – Planes Conference Table Top (for use with Column Base)

Rectangle, Pebble and Hexagon (One-Piece Top)

Rectangle

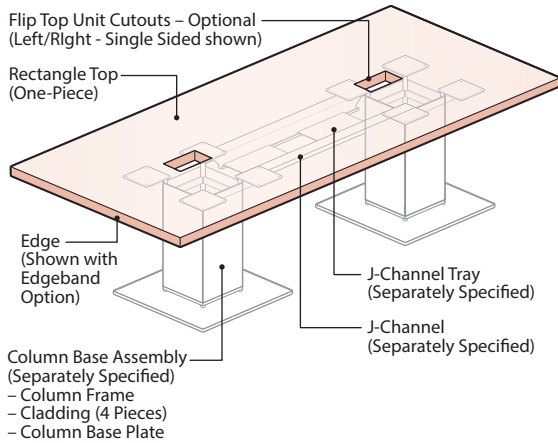

Pebble

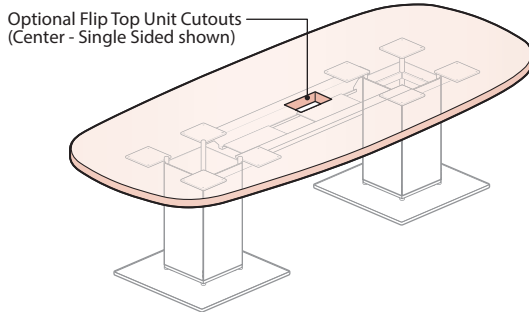

Hexagon

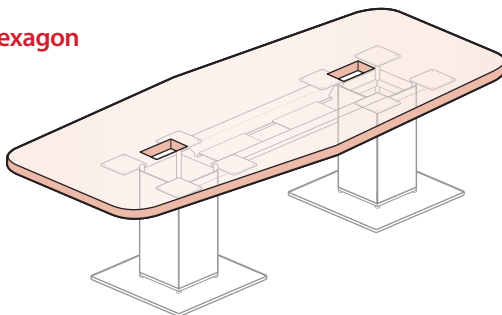

Component Materials/Finishes

COMPONENT NAME	MATERIALS/ FINISHES
1-Piece Top – Rectangle, Pebble, Hexagon	Laminate Top – Specified top color and specified edge trim color • Edge Options: (J) Edgeband, (F) Knife
	Wood Top – Specified top and edge trim wood finish color • Edge Options: (K) Edgeband, (U) Knife

Edge Options for Laminate Tops

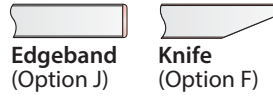

Edge Options for Wood Tops

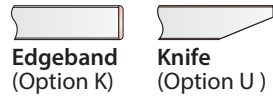

Note One Piece Laminate Tops are not available with (Option J) 3mm Laminate Edgeband or (Option F) Laminate Knife Edge.

Flip Top Unit Cutout Options

- Center Cutout Option**
• Includes 1 Flip Top Unit cutout (centered on top)
- Left/Right Cutout Option**
• Includes 2 Flip Top Unit cutouts (1 Left Cutout and 1 Right Cutout)

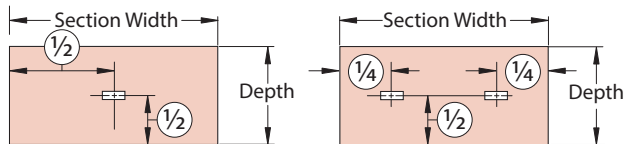

Note Cutout locations for Rectangle, Pebble and Hexagon Tops are the same.

Flip Top Unit Cutout Dimensions

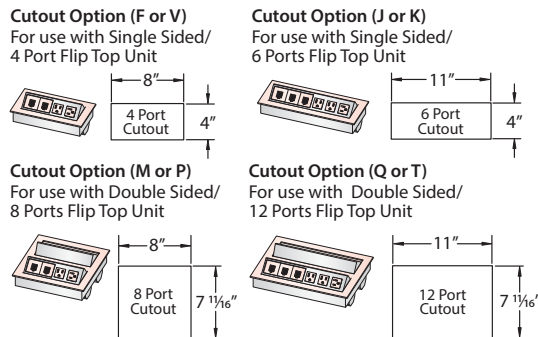

Note • Flip Top Units are separately specified.
• Double-Sided Flip Top Units cannot be placed over the 9" x 9" Column Frame.

Separately Specified Components

- One Piece Rectangle, Pebble and Hexagon Tops require a separately specified J Channel and (2) Column Bases.
- A Column Base is comprised of a separately specified Column Frame, Column Base Plates, and Cladding.
- Column Frames are available with 20", 28" and 40" heights.
- Optional J Channel Trays may be specified to provide additional wire management.

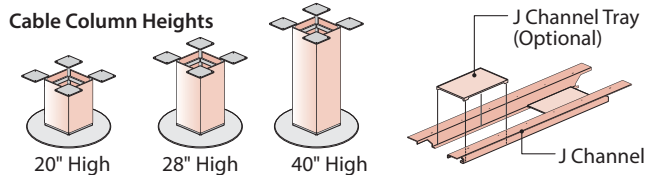

Note See the Floor Support Requirements – Specification Matrix, for Column Frames and Column Base Plates specification requirements.

Product Details – Planes Conference Table Top (for use with Column Base)

Rectangle, Pebble and Hexagon (One-Piece Top) – Dimensions

Dimensions

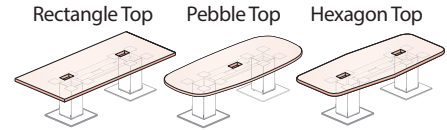
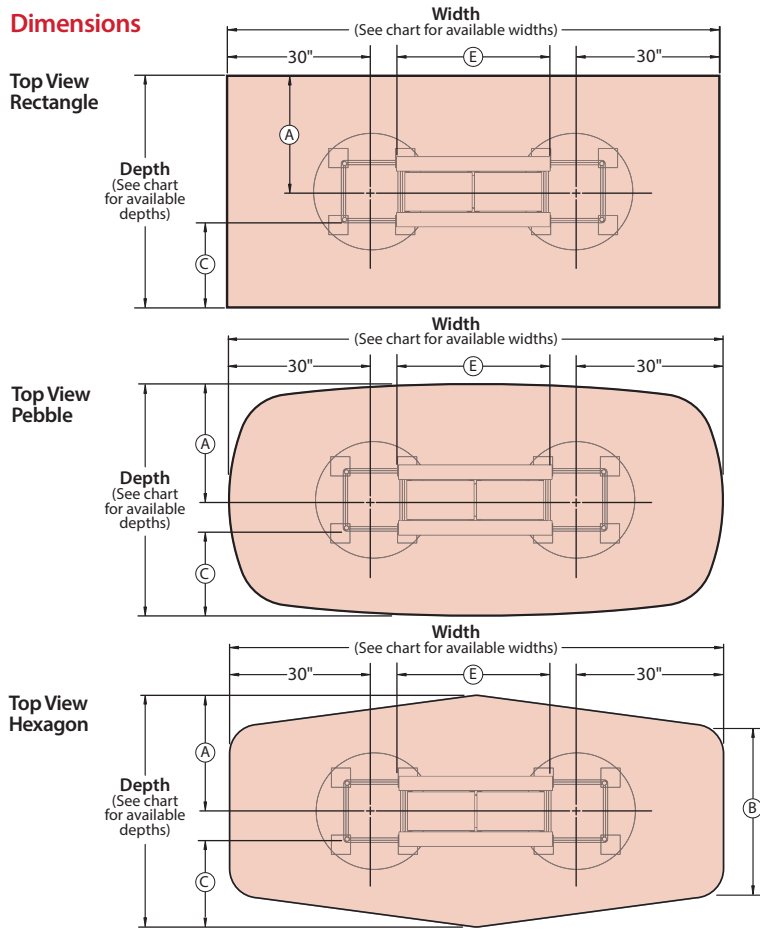

Flip Top Unit Cutout Location Centered Option (Top View)

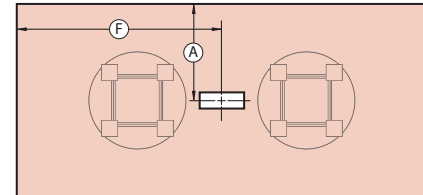

Flip Top Unit Cutout Location Left/Right Option (Top View)

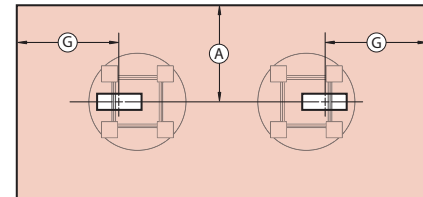

- Note**
- Cutout locations for Rectangle, Pebble and Hexagon Tops are the same.
 - Double-Sided Flip Top Units cannot be placed over the 9" x 9" Column Frames.

Front View

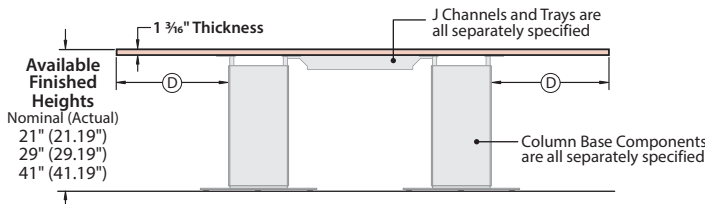

Dimensions

TABLE TOP				KNEESPACE								J CHANNEL / TRAYS				CUTOUTS	
Depth Nominal (Actual)	Width Nominal (Actual)	A	B	C				D				E				F	G
				Flat Cladding	Round Cladding	Flat Cladding	Round Cladding	9" x 9" Column Frames	12" x 12" Column Frames	9" x 9" Column Frames	12" x 12" Column Frames	J Channel Width	Maximum Number of Trays	J Channel Width	Maximum Number of Trays		
42" (41.68")	96" (95.68")	21"	38"	16"	14 1/2"	14 1/4"	12 1/2"	25"	23 1/2"	23 1/4"	21 1/8"	29"	1	26"	1	48"	24"
	102" (101.68")	21"	38"	16"	14 1/2"	14 1/4"	12 1/2"	25"	23 1/2"	23 1/4"	21 1/8"	35"	1	32"	1	51"	25 1/2"
	108" (107.68")	21"	38"	16"	14 1/2"	14 1/4"	12 1/2"	25"	23 1/2"	23 1/4"	21 1/8"	41"	2	38"	2	54"	27"
	114" (113.68")	21"	38"	16"	14 1/2"	14 1/4"	12 1/2"	25"	23 1/2"	23 1/4"	21 1/8"	47"	2	44"	2	57"	28 1/2"
	120" (119.68")	21"	38"	16"	14 1/2"	14 1/4"	12 1/2"	25"	23 1/2"	23 1/4"	21 1/8"	53"	3	50"	2	60"	30"
48" (47.68")	96" (95.68")	24"	44"	N/A	17 1/2"	N/A	15 1/8"	N/A	23 1/2"	N/A	21 1/8"	29"	1	26"	1	48"	24"
	102" (101.68")	24"	44"	N/A	17 1/2"	N/A	15 1/8"	N/A	23 1/2"	N/A	21 1/8"	35"	1	32"	1	51"	25 1/2"
	108" (107.68")	24"	44"	N/A	17 1/2"	N/A	15 1/8"	N/A	23 1/2"	N/A	21 1/8"	41"	2	38"	2	54"	27"
	114" (113.68")	24"	44"	N/A	17 1/2"	N/A	15 1/8"	N/A	23 1/2"	N/A	21 1/8"	47"	2	44"	2	57"	28 1/2"
	120" (119.68")	24"	44"	N/A	17 1/2"	N/A	15 1/8"	N/A	23 1/2"	N/A	21 1/8"	53"	3	50"	2	60"	30"
54" (53.68")	96" (95.68")	27"	50"	N/A	20 1/2"	N/A	18 1/8"	N/A	23 1/2"	N/A	21 1/8"	29"	1	26"	1	48"	24"
	102" (101.68")	27"	50"	N/A	20 1/2"	N/A	18 1/8"	N/A	23 1/2"	N/A	21 1/8"	35"	1	32"	1	51"	25 1/2"
	108" (107.68")	27"	50"	N/A	20 1/2"	N/A	18 1/8"	N/A	23 1/2"	N/A	21 1/8"	41"	2	38"	2	54"	27"
	114" (113.68")	27"	50"	N/A	20 1/2"	N/A	18 1/8"	N/A	23 1/2"	N/A	21 1/8"	47"	2	44"	2	57"	28 1/2"
	120" (119.68")	27"	50"	N/A	20 1/2"	N/A	18 1/8"	N/A	23 1/2"	N/A	21 1/8"	53"	3	50"	2	60"	30"
60" (59.68")	96" (95.68")	30"	56"	N/A	23 1/2"	N/A	21 1/8"	N/A	23 1/2"	N/A	21 1/8"	29"	1	26"	1	48"	24"
	102" (101.68")	30"	56"	N/A	23 1/2"	N/A	21 1/8"	N/A	23 1/2"	N/A	21 1/8"	35"	1	32"	1	51"	25 1/2"
	108" (107.68")	30"	56"	N/A	23 1/2"	N/A	21 1/8"	N/A	23 1/2"	N/A	21 1/8"	41"	2	38"	2	54"	27"
	114" (113.68")	30"	56"	N/A	23 1/2"	N/A	21 1/8"	N/A	23 1/2"	N/A	21 1/8"	47"	2	44"	2	57"	28 1/2"
	120" (119.68")	30"	56"	N/A	23 1/2"	N/A	21 1/8"	N/A	23 1/2"	N/A	21 1/8"	53"	3	50"	2	60"	30"

Product Details – Planes Conference Table Top (for use with Column Base)

Rectangle, Pebble and Hexagon (One-Piece Top) – Seating Capacity

Rectangle Top

		WIDTHS				
		96" Wide	102" Wide	108" Wide	114" Wide	120" Wide
DEPTHS	42" Deep	 8 Chairs Maximum	 8 Chairs Maximum	 10 Chairs Maximum	 10 Chairs Maximum	 10 Chairs Maximum
	48" Deep	 8 Chairs Maximum	 8 Chairs Maximum	 10 Chairs Maximum	 10 Chairs Maximum	 10 Chairs Maximum
	54" Deep	 10 Chairs Maximum	 10 Chairs Maximum	 12 Chairs Maximum	 12 Chairs Maximum	 12 Chairs Maximum
	60" Deep	 10 Chairs Maximum	 10 Chairs Maximum	 12 Chairs Maximum	 12 Chairs Maximum	 12 Chairs Maximum

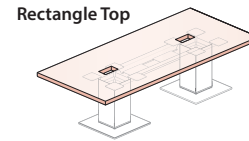

Pebble Top

		WIDTHS				
		96" Wide	102" Wide	108" Wide	114" Wide	120" Wide
DEPTHS	42" Deep	 8 Chairs Maximum	 8 Chairs Maximum	 10 Chairs Maximum	 10 Chairs Maximum	 10 Chairs Maximum
	48" Deep	 8 Chairs Maximum	 8 Chairs Maximum	 10 Chairs Maximum	 10 Chairs Maximum	 10 Chairs Maximum
	54" Deep	 10 Chairs Maximum	 10 Chairs Maximum	 12 Chairs Maximum	 12 Chairs Maximum	 12 Chairs Maximum
	60" Deep	 10 Chairs Maximum	 10 Chairs Maximum	 12 Chairs Maximum	 12 Chairs Maximum	 12 Chairs Maximum

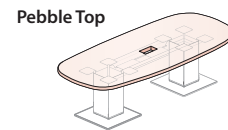

Hexagon Top

		WIDTHS				
		96" Wide	102" Wide	108" Wide	114" Wide	120" Wide
DEPTHS	42" Deep	 8 Chairs Maximum	 8 Chairs Maximum	 10 Chairs Maximum	 10 Chairs Maximum	 10 Chairs Maximum
	48" Deep	 8 Chairs Maximum	 8 Chairs Maximum	 10 Chairs Maximum	 10 Chairs Maximum	 10 Chairs Maximum
	54" Deep	 8 Chairs Maximum	 8 Chairs Maximum	 10 Chairs Maximum	 10 Chairs Maximum	 10 Chairs Maximum
	60" Deep	 10 Chairs Maximum	 10 Chairs Maximum	 12 Chairs Maximum	 12 Chairs Maximum	 12 Chairs Maximum

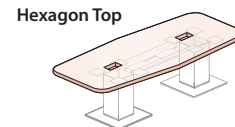

Note Recommended seating capacity based upon a width of 27" per chair.

Product Details – Planes Conference Table Top (for use with Column Base)

Rectangle, Pebble and Hexagon (One Piece Top) – Floor Support Requirements

- One Piece Rectangle, Pebble and Hexagon Tops require separately specified J Channels and (2) Column Bases.
- A Column Base is comprised of a separately specified Column Frame, Column Base Plate and Cladding.

Column Frame with Square Column Base Plate Specification Matrix

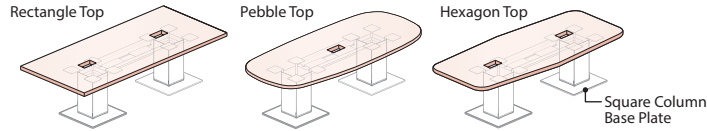

TABLE TOP DEPTH (Rectangle, Pebble or Hexagon)	COLUMN FRAME/COLUMN BASE PLATE SIZE COMBINATIONS				
	9" x 9" Column Frame		12" x 12" Column Frame		
	21" Square Base Plate	24" Square Base Plate	24" Square Base Plate	27" Square Base Plate	30" Square Base Plate
	⊘ Don't				
42" Deep Tops	⊘ Don't				
48" Deep Tops	⊘ Don't	⊘ Don't	⊘ Don't		
54" Deep Tops	⊘ Don't	⊘ Don't	⊘ Don't		
60" Deep Tops	⊘ Don't	⊘ Don't	⊘ Don't		

Column Frame with Round Column Base Plate Specification Matrix

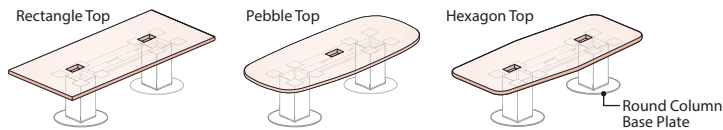

TABLE TOP DEPTH (Rectangle, Pebble or Hexagon)	COLUMN FRAME/COLUMN BASE PLATE SIZE COMBINATIONS				
	9" x 9" Column Frame		12" x 12" Column Frame		
	21" Round Base Plate	24" Round Base Plate	24" Round Base Plate	27" Round Base Plate	30" Round Base Plate
	⊘ Don't				
42" Deep Tops	⊘ Don't				
48" Deep Tops	⊘ Don't	⊘ Don't	⊘ Don't		
54" Deep Tops	⊘ Don't	⊘ Don't	⊘ Don't	⊘ Don't	
60" Deep Tops	⊘ Don't	⊘ Don't	⊘ Don't	⊘ Don't	

Note • Double-Sided Flip Top Units cannot be placed over the 9" Column Frame.

Product Details – Planes Conference Table Top (for use with Column Base)

Rectangle, Pebble and Hexagon (2-Piece Top)

Rectangle

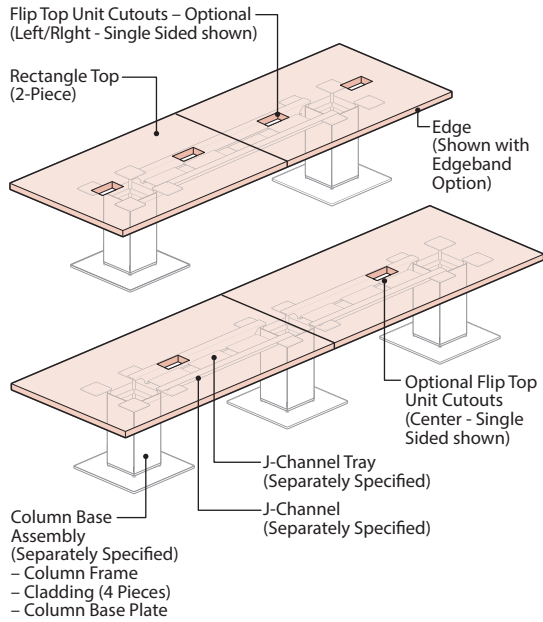

Pebble

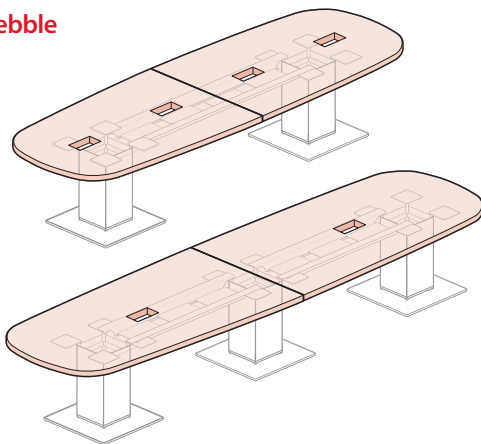

Hexagon

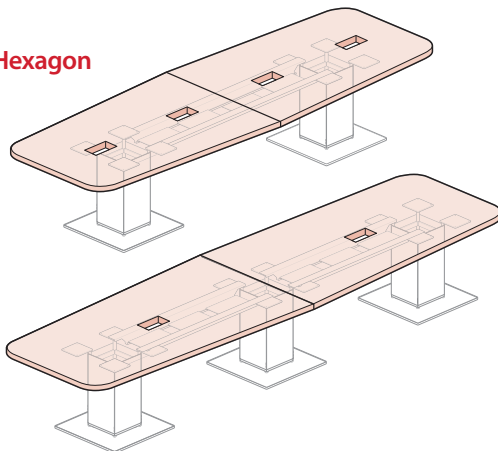

Component Materials/Finishes

COMPONENT NAME	MATERIALS/ FINISHES
2-Piece Top – Rectangle, Pebble, Hexagon	Laminate Top – Specified top color and specified edge trim color • Edge Options: (J) Edgeband, (F) Knife
	Wood Top – Specified top and edge trim wood finish color • Edge Options: (K) Edgeband, (U) Knife

Edge Options for Laminate Tops

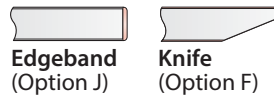

Edge Options for Wood Tops

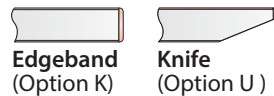

Flip Top Unit Cutout Options

Center Cutout Option

- Includes 1 Flip Top Unit Cutout (centered on each top piece)

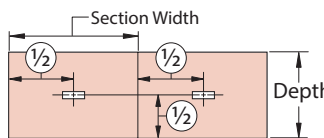

Left/Right Cutout Option

- Includes 2 Flip Top Unit Cutouts (1 left cutout and 1 right cutout on each top piece)

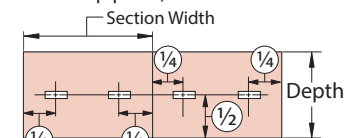

Note Cutout locations for Rectangle, Pebble and Hexagon Tops are the same.

Flip Top Unit Cutout Dimensions

Cutout Option (F or V)

- For use with Single Sided/ 4 Port Flip Top Unit

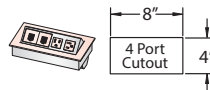

Cutout Option (J or K)

- For use with Single Sided/ 6 Ports Flip Top Unit

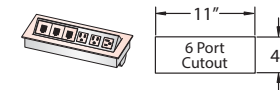

Cutout Option (M or P)

- For use with Double Sided/ 8 Ports Flip Top Unit

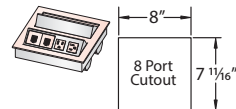

Cutout Option (Q or T)

- For use with Double Sided/ 12 Ports Flip Top Unit

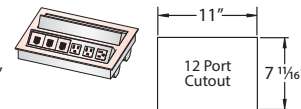

Note Flip Top Units are separately specified.

Separately Specified Components

- Two Piece Rectangle, Pebble and Hexagon Tops require a separately specified J Channel and (2 or 3) Column Bases.
- 126"-168" Wide Tops require (2) Column Bases for Floor Support
- 174"-180" Wide Tops require (3) Column Bases for Floor Support
- A Column Base is comprised of a separately specified Column Frame, Column Base Plate and Cladding.
- Column Frames are available with 20", 28", and 40" heights.

Cable Column Heights

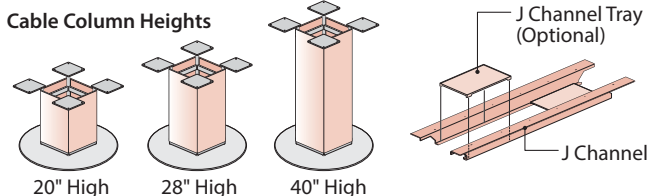

Note See the Floor Support Requirements – Specification Matrix, for Column Frames and Column Base Plates specification requirements.

Product Details – Planes Conference Table Top (for use with Column Base)

Rectangle, Pebble and Hexagon Tops (2-Piece Top) – Dimensions

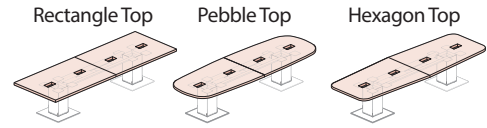
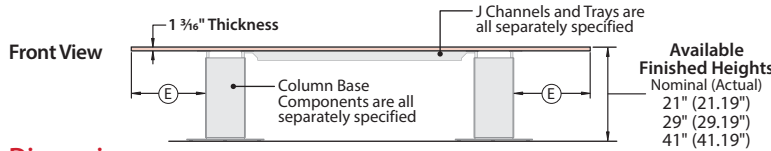
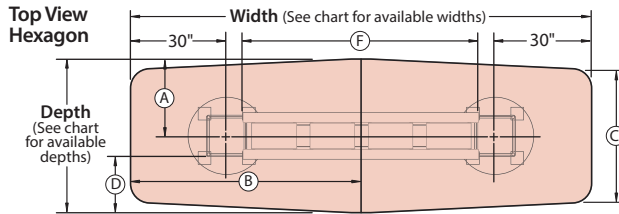
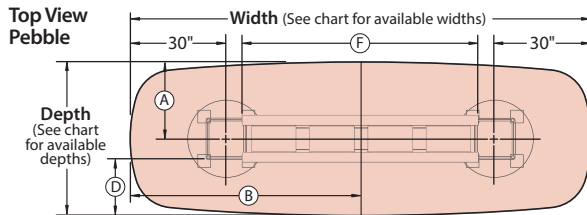
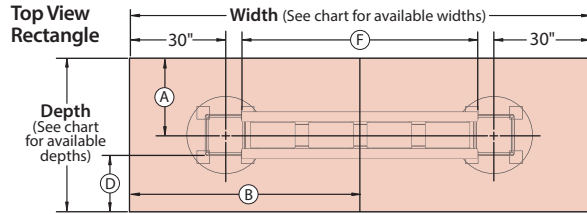

Flip Top Unit Cutout Locations Centered Option (Top View)

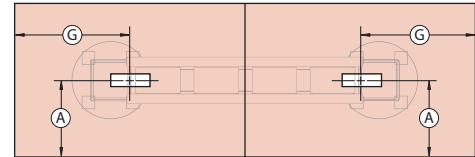

Left/Right Option (Top View)

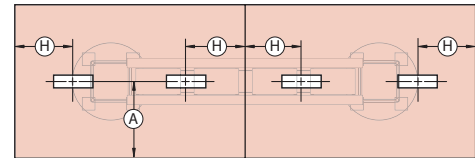

- Note**
- Cutout locations for Rectangle, Pebble and Hexagon Tops are the same.
 - Reference workware planning page when using workware products.

Dimensions

TABLE TOP					KNEESPACE								J CHANNEL / TRAYS				CUTOUTS	
Depth Nominal (Actual)	Width Nominal (Actual)	A	B	C	D				E				F				G	H
					Flat Cladding		Round Cladding		Flat Cladding		Round Cladding		9" x 9" Column Frames		12" x 12" Column Frames			
					9" x 9" Column Frames	12" x 12" Column Frames	9" x 9" Column Frames	12" x 12" Column Frames	9" x 9" Column Frames	12" x 12" Column Frames	9" x 9" Column Frames	12" x 12" Column Frames	J Channel Width	Maximum Number of Trays	J Channel Width	Maximum Number of Trays		
42" (41.68")	126" (125.36")	21"	63"	36"	16"	14 1/2"	14 1/4"	12 1/8"	24 13/16"	23 3/16"	23 1/8"	21"	59"	3	56"	3	31 1/2"	15 3/4"
	132" (131.36")	21"	66"	36"	16"	14 1/2"	14 1/4"	12 1/8"	24 13/16"	23 3/16"	23 1/8"	21"	65"	3	62"	3	33"	16 1/2"
	138" (137.36")	21"	69"	36"	16"	14 1/2"	14 1/4"	12 1/8"	24 13/16"	23 3/16"	23 1/8"	21"	71"	4	68"	4	34 1/2"	17 1/4"
	144" (143.36")	21"	72"	36"	16"	14 1/2"	14 1/4"	12 1/8"	24 13/16"	23 3/16"	23 1/8"	21"	77"	4	74"	4	36"	18"
	150" (149.36")	21"	75"	36"	16"	14 1/2"	14 1/4"	12 1/8"	24 13/16"	23 3/16"	23 1/8"	21"	83"	5	80"	5	37 1/2"	18 3/4"
	156" (155.36")	21"	78"	36"	16"	14 1/2"	14 1/4"	12 1/8"	24 13/16"	23 3/16"	23 1/8"	21"	89"	5	86"	5	39"	19 1/2"
	162" (161.36")	21"	81"	36"	16"	14 1/2"	14 1/4"	12 1/8"	24 13/16"	23 3/16"	23 1/8"	21"	95"	6	92"	6	40 1/2"	20 1/4"
48" (47.68")	168" (167.36")	21"	84"	36"	16"	14 1/2"	14 1/4"	12 1/8"	24 13/16"	23 3/16"	23 1/8"	21"	101"	6	98"	6	42"	21"
	126" (125.36")	24"	63"	42"	N/A	17 1/2"	N/A	15 1/8"	N/A	23 3/16"	N/A	21"	59"	3	56"	3	31 1/2"	15 3/4"
	132" (131.36")	24"	66"	42"	N/A	17 1/2"	N/A	15 1/8"	N/A	23 3/16"	N/A	21"	65"	3	62"	3	33"	16 1/2"
	138" (137.36")	24"	69"	42"	N/A	17 1/2"	N/A	15 1/8"	N/A	23 3/16"	N/A	21"	71"	4	68"	4	34 1/2"	17 1/4"
	144" (143.36")	24"	72"	42"	N/A	17 1/2"	N/A	15 1/8"	N/A	23 3/16"	N/A	21"	77"	4	74"	4	36"	18"
	150" (149.36")	24"	75"	42"	N/A	17 1/2"	N/A	15 1/8"	N/A	23 3/16"	N/A	21"	83"	5	80"	5	37 1/2"	18 3/4"
	156" (155.36")	24"	78"	42"	N/A	17 1/2"	N/A	15 1/8"	N/A	23 3/16"	N/A	21"	89"	5	86"	5	39"	19 1/2"
54" (53.68")	162" (161.36")	24"	81"	42"	N/A	17 1/2"	N/A	15 1/8"	N/A	23 3/16"	N/A	21"	95"	6	92"	6	40 1/2"	20 1/4"
	168" (167.36")	24"	84"	42"	N/A	17 1/2"	N/A	15 1/8"	N/A	23 3/16"	N/A	21"	101"	6	98"	6	42"	21"
	126" (125.36")	27"	63"	48"	N/A	20 1/2"	N/A	18 1/8"	N/A	23 3/16"	N/A	21"	59"	3	56"	3	31 1/2"	15 3/4"
	132" (131.36")	27"	66"	48"	N/A	20 1/2"	N/A	18 1/8"	N/A	23 3/16"	N/A	21"	65"	3	62"	3	33"	16 1/2"
	138" (137.36")	27"	69"	48"	N/A	20 1/2"	N/A	18 1/8"	N/A	23 3/16"	N/A	21"	71"	4	68"	4	34 1/2"	17 1/4"
	144" (143.36")	27"	72"	48"	N/A	20 1/2"	N/A	18 1/8"	N/A	23 3/16"	N/A	21"	77"	4	74"	4	36"	18"
	150" (149.36")	27"	75"	48"	N/A	20 1/2"	N/A	18 1/8"	N/A	23 3/16"	N/A	21"	83"	5	80"	5	37 1/2"	18 3/4"
60" (59.68")	156" (155.36")	27"	78"	48"	N/A	20 1/2"	N/A	18 1/8"	N/A	23 3/16"	N/A	21"	89"	5	86"	5	39"	19 1/2"
	162" (161.36")	27"	81"	48"	N/A	20 1/2"	N/A	18 1/8"	N/A	23 3/16"	N/A	21"	95"	6	92"	6	40 1/2"	20 1/4"
	168" (167.36")	27"	84"	48"	N/A	20 1/2"	N/A	18 1/8"	N/A	23 3/16"	N/A	21"	101"	6	98"	6	42"	21"
	126" (125.36")	30"	63"	54"	N/A	23 1/2"	N/A	21 1/8"	N/A	23 3/16"	N/A	21"	59"	3	56"	3	31 1/2"	15 3/4"
	132" (131.36")	30"	66"	54"	N/A	23 1/2"	N/A	21 1/8"	N/A	23 3/16"	N/A	21"	65"	3	62"	3	33"	16 1/2"
	138" (137.36")	30"	69"	54"	N/A	23 1/2"	N/A	21 1/8"	N/A	23 3/16"	N/A	21"	71"	4	68"	4	34 1/2"	17 1/4"
	144" (143.36")	30"	72"	54"	N/A	23 1/2"	N/A	21 1/8"	N/A	23 3/16"	N/A	21"	77"	4	74"	4	36"	18"
150" (149.36")	30"	75"	54"	N/A	23 1/2"	N/A	21 1/8"	N/A	23 3/16"	N/A	21"	83"	5	80"	5	37 1/2"	18 3/4"	
156" (155.36")	30"	78"	54"	N/A	23 1/2"	N/A	21 1/8"	N/A	23 3/16"	N/A	21"	89"	5	86"	5	39"	19 1/2"	
162" (161.36")	30"	81"	54"	N/A	23 1/2"	N/A	21 1/8"	N/A	23 3/16"	N/A	21"	95"	6	92"	6	40 1/2"	20 1/4"	
168" (167.36")	30"	84"	54"	N/A	23 1/2"	N/A	21 1/8"	N/A	23 3/16"	N/A	21"	101"	6	98"	6	42"	21"	

Product Details – Planes Conference Table Top (for use with Column Base)

Rectangle, Pebble and Hexagon (2-Piece Top) – Dimensions

Dimensions – 2-Piece Top / Requires Three Column Bases (174"-180" Wide Tops)

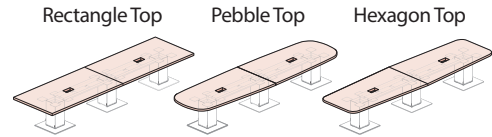
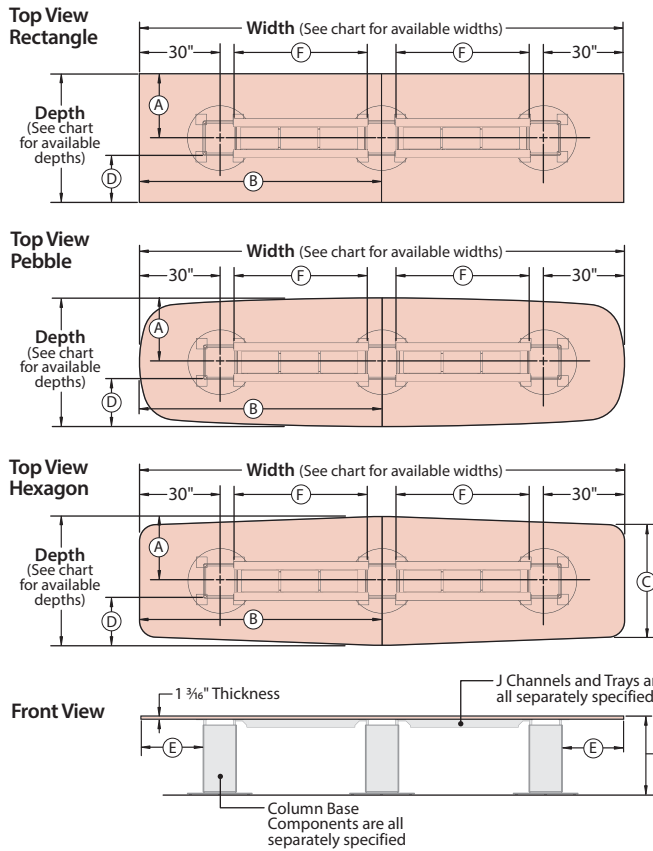

Flip Top Unit Cutout Locations Centered Option (Top View)

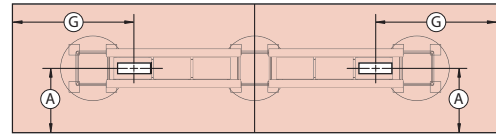

Left/Right Option (Top View)

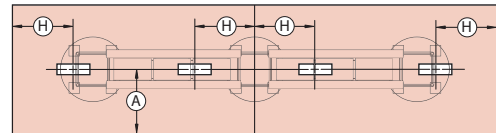

- Note**
- Cutout locations for Rectangle, Pebble and Hexagon Tops are the same.
 - Reference workware planning page when using workware products.

Dimensions

TABLE TOP					KNEESPACE								J CHANNEL / TRAYS				CUTOUTS	
Depth Nominal (Actual)	Width Nominal (Actual)	A	B	C	D				E				F				G	H
					Flat Cladding		Round Cladding		Flat Cladding		Round Cladding		9" x 9" Column Frames		12" x 12" Column Frames			
					9" x 9" Column Frames	12" x 12" Column Frames	9" x 9" Column Frames	12" x 12" Column Frames	9" x 9" Column Frames	12" x 12" Column Frames	9" x 9" Column Frames	12" x 12" Column Frames	J Channel Width	Maximum Number of Trays	J Channel Width	Maximum Number of Trays		
42" (41.68")	174" (173.36")	21"	87"	36"	16"	14 1/2"	14 1/4"	12 1/8"	24 13/16"	23 3/16"	23 1/8"	20 15/16"	59"	3	56"	3	31 1/2"	15 3/4"
	180" (179.36")	21"	90"	36"	16"	14 1/2"	14 1/4"	12 1/8"	24 13/16"	23 3/16"	23 1/8"	20 15/16"	65"	3	62"	3	33"	16 1/2"
48" (47.68")	174" (173.36")	24"	87"	42"	N/A	17 1/2"	N/A	15 1/8"	N/A	23 3/16"	N/A	20 15/16"	59"	3	56"	3	31 1/2"	15 3/4"
	180" (179.36")	24"	90"	42"	N/A	17 1/2"	N/A	15 1/8"	N/A	23 3/16"	N/A	20 15/16"	65"	3	62"	3	33"	16 1/2"
54" (53.68")	174" (173.36")	27"	87"	48"	N/A	20 1/2"	N/A	18 3/8"	N/A	23 3/16"	N/A	20 15/16"	59"	3	56"	3	31 1/2"	15 3/4"
	180" (179.36")	27"	90"	48"	N/A	20 1/2"	N/A	18 3/8"	N/A	23 3/16"	N/A	20 15/16"	65"	3	62"	3	33"	16 1/2"
60" (59.68")	174" (173.36")	30"	87"	54"	N/A	23 1/2"	N/A	21 1/8"	N/A	23 3/16"	N/A	20 15/16"	59"	3	56"	3	31 1/2"	15 3/4"
	180" (179.36")	30"	90"	54"	N/A	23 1/2"	N/A	21 1/8"	N/A	23 3/16"	N/A	20 15/16"	65"	3	62"	3	33"	16 1/2"

Product Details – Planes Conference Table Top (for use with Column Base)

Rectangle, Pebble and Hexagon (2-Piece Top) – Seating Capacity

Table Sizes and Seating Capacities

Rectangle Top

- 126"-168" wide requires (2) separately specified Column Bases.
- 174"-180" wide requires (3) separately specified Column Bases.

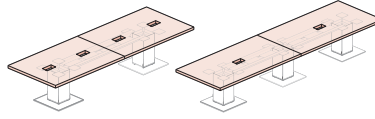

		WIDTHS									
		126" Wide	132" Wide	138" Wide	144" Wide	150" Wide	156" Wide	162" Wide	168" Wide	174" Wide	180" Wide
DEPTHS	42" Deep	10 Chairs Maximum (2 Columns)	10 Chairs Maximum (2 Columns)	12 Chairs Maximum (2 Columns)	12 Chairs Maximum (2 Columns)	12 Chairs Maximum (2 Columns)	12 Chairs Maximum (2 Columns)	14 Chairs Maximum (2 Columns)	14 Chairs Maximum (2 Columns)	14 Chairs Maximum (3 Columns)	14 Chairs Maximum (3 Columns)
	48" Deep	10 Chairs Maximum (2 Columns)	10 Chairs Maximum (2 Columns)	12 Chairs Maximum (2 Columns)	12 Chairs Maximum (2 Columns)	12 Chairs Maximum (2 Columns)	12 Chairs Maximum (2 Columns)	14 Chairs Maximum (2 Columns)	14 Chairs Maximum (2 Columns)	14 Chairs Maximum (3 Columns)	14 Chairs Maximum (3 Columns)
	54" Deep	10 Chairs Maximum (2 Columns)	10 Chairs Maximum (2 Columns)	12 Chairs Maximum (2 Columns)	12 Chairs Maximum (2 Columns)	12 Chairs Maximum (2 Columns)	12 Chairs Maximum (2 Columns)	14 Chairs Maximum (2 Columns)	14 Chairs Maximum (2 Columns)	14 Chairs Maximum (3 Columns)	14 Chairs Maximum (3 Columns)
	60" Deep	12 Chairs Maximum (2 Columns)	12 Chairs Maximum (2 Columns)	14 Chairs Maximum (2 Columns)	14 Chairs Maximum (2 Columns)	14 Chairs Maximum (2 Columns)	14 Chairs Maximum (2 Columns)	16 Chairs Maximum (2 Columns)	16 Chairs Maximum (2 Columns)	16 Chairs Maximum (3 Columns)	16 Chairs Maximum (3 Columns)

Pebble Top

- 126"-168" wide requires (2) separately specified Column Bases.
- 174"-180" wide requires (3) separately specified Column Bases.

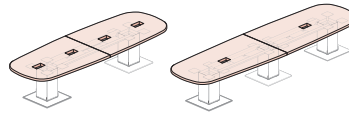

		WIDTHS									
		126" Wide	132" Wide	138" Wide	144" Wide	150" Wide	156" Wide	162" Wide	168" Wide	174" Wide	180" Wide
DEPTHS	42" Deep	10 Chairs Maximum (2 Columns)	10 Chairs Maximum (2 Columns)	10 Chairs Maximum (2 Columns)	10 Chairs Maximum (2 Columns)	10 Chairs Maximum (2 Columns)	12 Chairs Maximum (2 Columns)	14 Chairs Maximum (2 Columns)	16 Chairs Maximum (2 Columns)	14 Chairs Maximum (3 Columns)	14 Chairs Maximum (3 Columns)
	48" Deep	10 Chairs Maximum (2 Columns)	10 Chairs Maximum (2 Columns)	10 Chairs Maximum (2 Columns)	10 Chairs Maximum (2 Columns)	10 Chairs Maximum (2 Columns)	12 Chairs Maximum (2 Columns)	14 Chairs Maximum (2 Columns)	16 Chairs Maximum (2 Columns)	14 Chairs Maximum (3 Columns)	14 Chairs Maximum (3 Columns)
	54" Deep	10 Chairs Maximum (2 Columns)	10 Chairs Maximum (2 Columns)	12 Chairs Maximum (2 Columns)	12 Chairs Maximum (2 Columns)	12 Chairs Maximum (2 Columns)	12 Chairs Maximum (2 Columns)	14 Chairs Maximum (2 Columns)	14 Chairs Maximum (2 Columns)	14 Chairs Maximum (3 Columns)	14 Chairs Maximum (3 Columns)
	60" Deep	12 Chairs Maximum (2 Columns)	12 Chairs Maximum (2 Columns)	12 Chairs Maximum (2 Columns)	12 Chairs Maximum (2 Columns)	14 Chairs Maximum (2 Columns)	14 Chairs Maximum (2 Columns)	16 Chairs Maximum (2 Columns)	16 Chairs Maximum (2 Columns)	16 Chairs Maximum (3 Columns)	16 Chairs Maximum (3 Columns)

Note Recommended seating capacity based upon a width of 27" per chair.

Product Details – Planes Conference Table Top (for use with Column Base)

Rectangle, Pebble and Hexagon (2-Piece Top) – Seating Capacity

Table Sizes and Seating Capacities

Hexagon Top

- 126"-168" wide requires (2) separately specified Column Bases.
- 174"-180" wide requires (3) separately specified Column Bases.

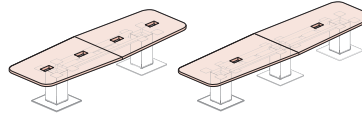

		WIDTHS									
		126" Wide	132" Wide	138" Wide	144" Wide	150" Wide	156" Wide	162" Wide	168" Wide	174" Wide	180" Wide
DEPTHS	42" Deep	10 Chairs Maximum (2 Columns)	10 Chairs Maximum (2 Columns)	12 Chairs Maximum (2 Columns)	12 Chairs Maximum (2 Columns)	12 Chairs Maximum (2 Columns)	12 Chairs Maximum (2 Columns)	14 Chairs Maximum (2 Columns)	14 Chairs Maximum (2 Columns)	14 Chairs Maximum (3 Columns)	14 Chairs Maximum (3 Columns)
	48" Deep	10 Chairs Maximum (2 Columns)	10 Chairs Maximum (2 Columns)	12 Chairs Maximum (2 Columns)	12 Chairs Maximum (2 Columns)	12 Chairs Maximum (2 Columns)	12 Chairs Maximum (2 Columns)	14 Chairs Maximum (2 Columns)	14 Chairs Maximum (2 Columns)	14 Chairs Maximum (3 Columns)	14 Chairs Maximum (3 Columns)
	54" Deep	10 Chairs Maximum (2 Columns)	10 Chairs Maximum (2 Columns)	12 Chairs Maximum (2 Columns)	12 Chairs Maximum (2 Columns)	12 Chairs Maximum (2 Columns)	12 Chairs Maximum (2 Columns)	14 Chairs Maximum (2 Columns)	14 Chairs Maximum (2 Columns)	14 Chairs Maximum (3 Columns)	14 Chairs Maximum (3 Columns)
	60" Deep	12 Chairs Maximum (2 Columns)	12 Chairs Maximum (2 Columns)	14 Chairs Maximum (2 Columns)	14 Chairs Maximum (2 Columns)	14 Chairs Maximum (2 Columns)	14 Chairs Maximum (2 Columns)	16 Chairs Maximum (2 Columns)	16 Chairs Maximum (2 Columns)	16 Chairs Maximum (3 Columns)	16 Chairs Maximum (3 Columns)

Note Recommended seating capacity based upon a width of 27" per chair.

Product Details – Planes Conference Table Top (for use with Column Base)

Rectangle, Pebble and Hexagon (2-Piece Top) – Floor Support Requirements

- 2-Piece Rectangle, Pebble and Hexagon Tops require separately specified J Channel and Column Bases.
- 126"-168" wide 2-Piece Tops require (2) separately specified Column Bases.
- 174"-180" wide 2-Piece Tops require (3) separately specified Column Bases.
- A Column Base is comprised of a separately specified Column Frame, Column Base Plate and Cladding.

Column Frame with Square Column Base Plate Specification Matrix

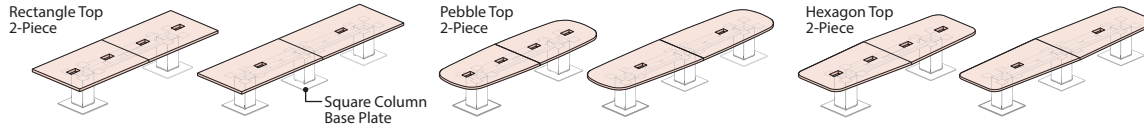

TABLE TOP DEPTH (Rectangle, Pebble or Hexagon)	COLUMN FRAME/COLUMN BASE PLATE SIZE COMBINATIONS				
	9" x 9" Column Frame		12" x 12" Column Frame		
	21" Square Base Plate	24" Square Base Plate	24" Square Base Plate	27" Square Base Plate	30" Square Base Plate
	⊘ Don't				
42" Deep Tops	⊘ Don't				
48" Deep Tops	⊘ Don't	⊘ Don't	⊘ Don't		
54" Deep Tops	⊘ Don't	⊘ Don't	⊘ Don't		
60" Deep Tops	⊘ Don't	⊘ Don't	⊘ Don't		

Column Frame with Round Column Base Plate Specification Matrix

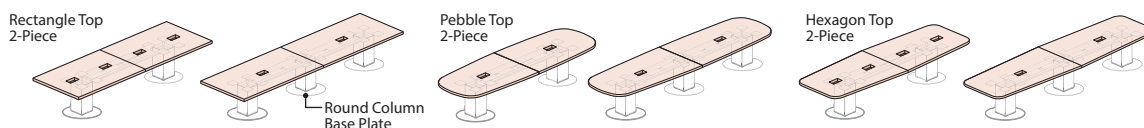

TABLE TOP DEPTH (Rectangle, Pebble or Hexagon)	COLUMN FRAME/COLUMN BASE PLATE SIZE COMBINATIONS				
	9" x 9" Column Frame		12" x 12" Column Frame		
	21" Round Base Plate	24" Round Base Plate	24" Round Base Plate	27" Round Base Plate	30" Round Base Plate
	⊘ Don't				
42" Deep Tops	⊘ Don't				
48" Deep Tops	⊘ Don't	⊘ Don't	⊘ Don't		
54" Deep Tops	⊘ Don't	⊘ Don't	⊘ Don't	⊘ Don't	
60" Deep Tops	⊘ Don't	⊘ Don't	⊘ Don't	⊘ Don't	

Note • Double-Sided Flip Top Units cannot be placed over the 9" Column Frame.

Product Details – Planes Conference Table Top (for use with Column Base)

Rectangle, Pebble and Hexagon (3-Piece Top)

Rectangle

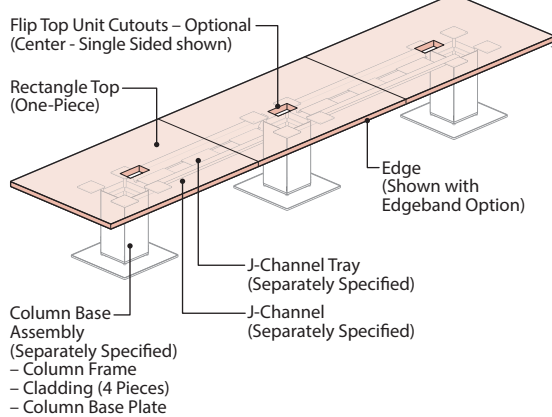

Pebble

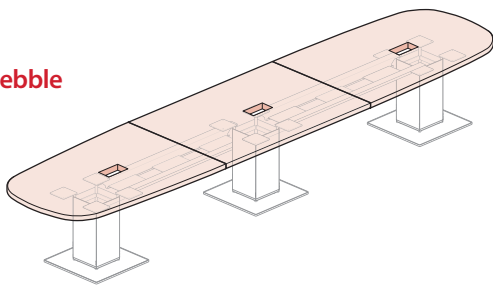

Hexagon

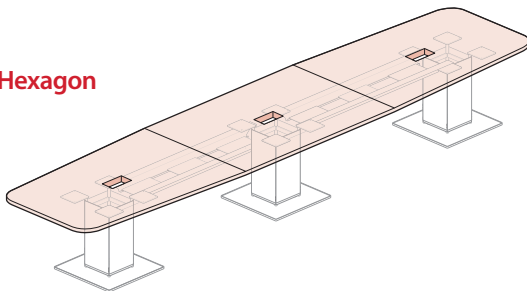

Component Materials/Finishes

COMPONENT NAME	MATERIALS/ FINISHES
3-Piece Top – Rectangle, Pebble, Hexagon	Laminate Top – Specified top color and specified edge trim color • Edge Options: (J) Edgeband, (F) Knife
	Wood Top – Specified top and edge trim wood finish color • Edge Options: (K) Edgeband, (U) Knife

Edge Options for Laminate Tops

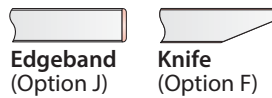

Edge Options for Wood Tops

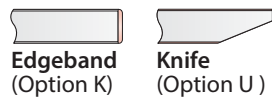

Flip Top Unit Cutout Options

Center Cutout Option

- Includes 1 Flip Top Unit cutout (centered on top)

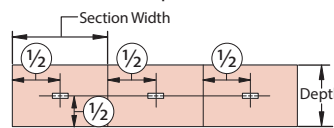

Left/Right Cutout Option

- Includes 2 Flip Top Unit cutouts (1 Left Cutout and 1 Right Cutout)

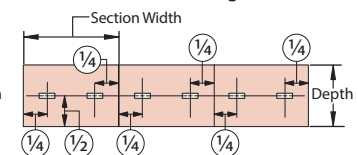

Note Cutout locations for Rectangle, Pebble and Hexagon Tops are the same.

Flip Top Unit Cutout Dimensions

Cutout Option (F or V)

- For use with Single Sided/ 4 Port Flip Top Unit

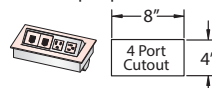

Cutout Option (J or K)

- For use with Single Sided/ 6 Ports Flip Top Unit

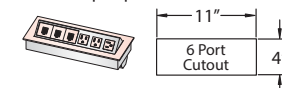

Cutout Option (M or P)

- For use with Double Sided/ 8 Ports Flip Top Unit

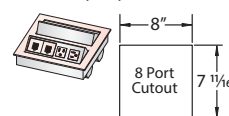

Cutout Option (Q or T)

- For use with Double Sided/ 12 Ports Flip Top Unit

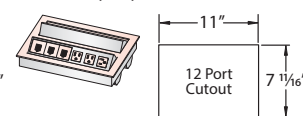

Note Flip Top Units are separately specified.

Separately Specified Components

- Two Piece Rectangle, Pebble and Hexagon Tops require a separately specified J Channel and (3) Column Bases.
- A Column Base is comprised of a separately specified Column Frame, Column Base Plate and Cladding.
- Column Frames are available with 20", 28" and 40" heights.

Cable Column Heights

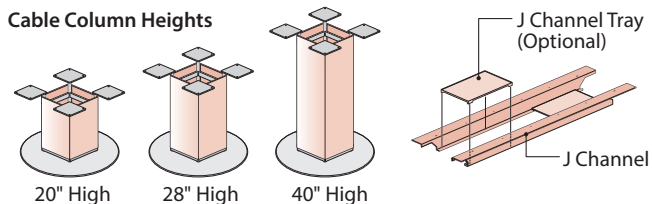

Note See the Floor Support Requirements – Specification Matrix, for Column Frames and Column Base Plates specification requirements.

Product Details – Planes Conference Table Top (for use with Column Base)

Rectangle, Pebble and Hexagon (3-Piece Top) – Dimensions

(See the chart on the following page specific Dimensions)

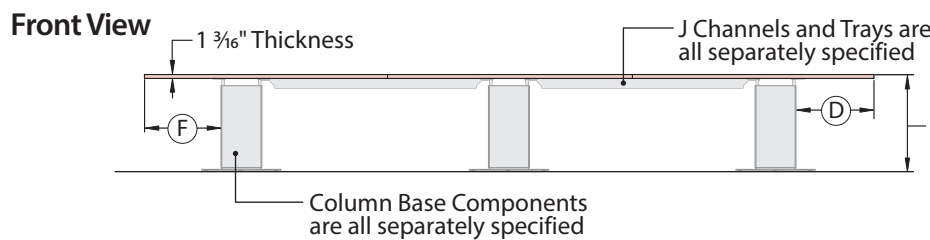
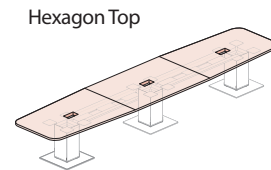
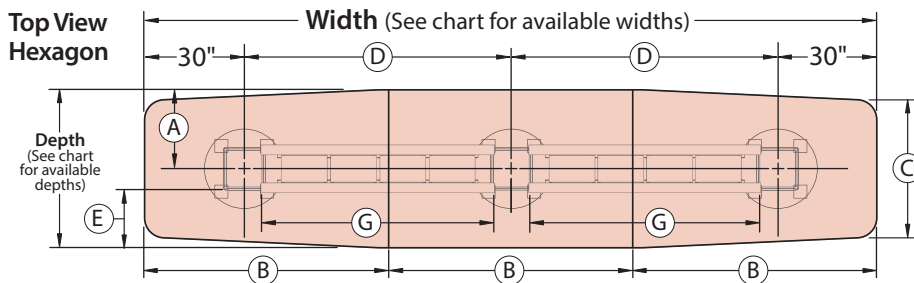
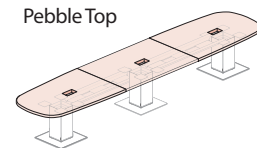
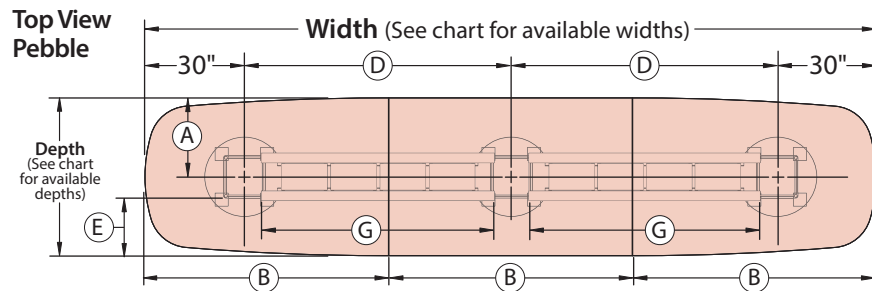
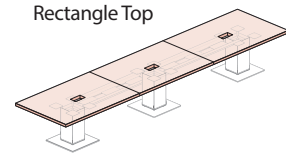
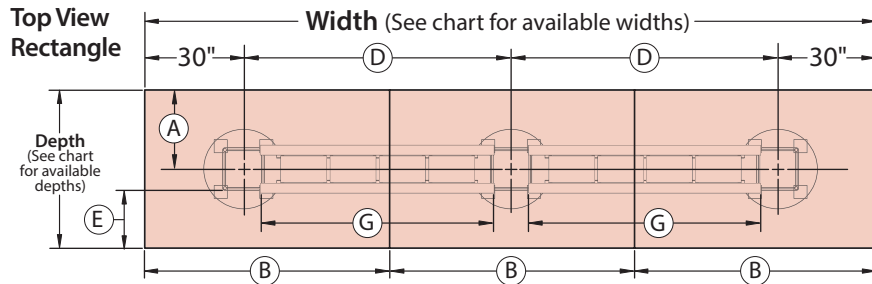

Available Finished Heights

Nominal	(Actual)
21"	(21.19")
29"	(29.19")
41"	(41.19")

Flip Top Unit Cutout Locations

Centered Option (Top View)

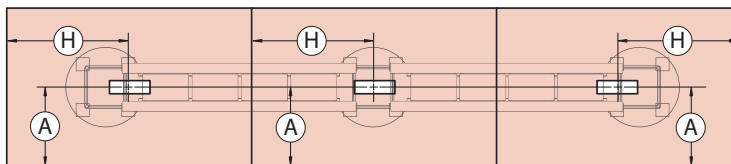

Left/Right Option (Top View)

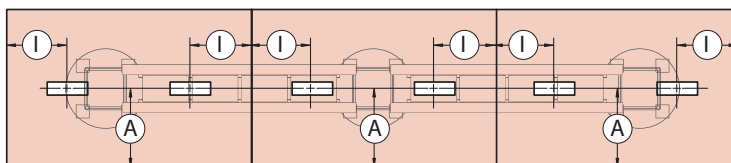

Note • Cutout locations for Rectangle, Pebble and Hexagon Tops are the same.
• Reference workware planning page when using workware products.

Product Details – Planes Conference Table Top (for use with Column Base)

Rectangle, Pebble and Hexagon (3-Piece Top) – Dimensions

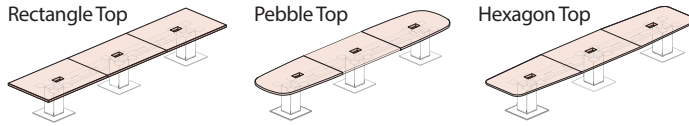

TABLE TOP						KNEESPACE								J CHANNEL / TRAYS				CUTOUPS			
Depth Nominal (Actual)	Width Nominal (Actual)	A	B	C	D	E				F				G				H	I		
						Flat Cladding		Round Cladding		Flat Cladding		Round Cladding		9" x 9" Column Frames		12" x 12" Column Frames				Centered Cutout Option	Left/Right Cutouts Option
						9" x 9" Column Frames	12" x 12" Column Frames	9" x 9" Column Frames	12" x 12" Column Frames	9" x 9" Column Frames	12" x 12" Column Frames	9" x 9" Column Frames	12" x 12" Column Frames	J Channel Width	Max. Number of Trays	J Channel Width	Max. Number of Trays				
42" (41.68")	186" (185.04")	21"	62"	36"	62 13/16"	16"	14 1/2"	14 1/4"	12 1/8"	24 13/16"	23 3/16"	23 1/8"	20 15/16"	56"	3	53"	3	31"	15 1/2"		
	192" (191.04")	21"	64"	36"	65 13/16"	16"	14 1/2"	14 1/4"	12 1/8"	24 13/16"	23 3/16"	23 1/8"	20 15/16"	59"	3	56"	3	32"	16"		
	198" (197.04")	21"	66"	36"	68 13/16"	16"	14 1/2"	14 1/4"	12 1/8"	24 13/16"	23 3/16"	23 1/8"	20 15/16"	62"	3	59"	3	33"	16 1/2"		
	204" (203.04")	21"	68"	36"	71 13/16"	16"	14 1/2"	14 1/4"	12 1/8"	24 13/16"	23 3/16"	23 1/8"	20 15/16"	65"	3	62"	3	34"	17"		
	210" (219.04")	21"	70"	36"	74 13/16"	16"	14 1/2"	14 1/4"	12 1/8"	24 13/16"	23 3/16"	23 1/8"	20 15/16"	68"	4	65"	3	35"	17 1/2"		
	216" (215.04")	21"	72"	36"	77 13/16"	16"	14 1/2"	14 1/4"	12 1/8"	24 13/16"	23 3/16"	23 1/8"	20 15/16"	71"	4	68"	4	36"	18"		
	222" (221.04")	21"	74"	36"	80 13/16"	16"	14 1/2"	14 1/4"	12 1/8"	24 13/16"	23 3/16"	23 1/8"	20 15/16"	74"	4	71"	4	37"	18 1/2"		
	228" (227.04")	21"	76"	36"	83 13/16"	16"	14 1/2"	14 1/4"	12 1/8"	24 13/16"	23 3/16"	23 1/8"	20 15/16"	77"	4	74"	4	38"	19		
	234" (233.04")	21"	78"	36"	86 13/16"	16"	14 1/2"	14 1/4"	12 1/8"	24 13/16"	23 3/16"	23 1/8"	20 15/16"	80"	5	77"	4	39"	19 1/2"		
	240" (239.04")	21"	80"	36"	89 13/16"	16"	14 1/2"	14 1/4"	12 1/8"	24 13/16"	23 3/16"	23 1/8"	20 15/16"	83"	5	80"	5	40"	20"		
	246" (245.04")	21"	82"	36"	92 13/16"	16"	14 1/2"	14 1/4"	12 1/8"	24 13/16"	23 3/16"	23 1/8"	20 15/16"	86"	5	83"	5	41"	20 1/2"		
	252" (251.04")	21"	84"	36"	95 13/16"	16"	14 1/2"	14 1/4"	12 1/8"	24 13/16"	23 3/16"	23 1/8"	20 15/16"	89"	5	86"	5	42"	21"		
	258" (257.04")	21"	86"	36"	98 13/16"	16"	14 1/2"	14 1/4"	12 1/8"	24 13/16"	23 3/16"	23 1/8"	20 15/16"	92"	5	89"	5	43"	21 1/2"		
	264" (263.04")	21"	88"	36"	101 13/16"	16"	14 1/2"	14 1/4"	12 1/8"	24 13/16"	23 3/16"	23 1/8"	20 15/16"	92"	6	92"	5	44"	22		
	270" (269.04")	21"	90"	36"	104 13/16"	16"	14 1/2"	14 1/4"	12 1/8"	24 13/16"	23 3/16"	23 1/8"	20 15/16"	98"	6	95"	6	45"	23 1/2"		
48" (47.68")	186" (185.04")	24"	62"	42"	62 13/16"	N/A	17 1/2"	N/A	15 1/8"	N/A	23 3/16"	N/A	20 15/16"	56"	3	53"	3	31"	15 1/2"		
	192" (191.04")	24"	64"	42"	65 13/16"	N/A	17 1/2"	N/A	15 1/8"	N/A	23 3/16"	N/A	20 15/16"	59"	3	56"	3	32"	16"		
	198" (197.04")	24"	66"	42"	68 13/16"	N/A	17 1/2"	N/A	15 1/8"	N/A	23 3/16"	N/A	20 15/16"	62"	3	59"	3	33"	16 1/2"		
	204" (203.04")	24"	68"	42"	71 13/16"	N/A	17 1/2"	N/A	15 1/8"	N/A	23 3/16"	N/A	20 15/16"	65"	3	62"	3	34"	17"		
	210" (219.04")	24"	70"	42"	74 13/16"	N/A	17 1/2"	N/A	15 1/8"	N/A	23 3/16"	N/A	20 15/16"	68"	4	65"	3	35"	17 1/2"		
	216" (215.04")	24"	72"	42"	77 13/16"	N/A	17 1/2"	N/A	15 1/8"	N/A	23 3/16"	N/A	20 15/16"	71"	4	68"	4	36"	18"		
	222" (221.04")	24"	74"	42"	80 13/16"	N/A	17 1/2"	N/A	15 1/8"	N/A	23 3/16"	N/A	20 15/16"	74"	4	71"	4	37"	18 1/2"		
	228" (227.04")	24"	76"	42"	83 13/16"	N/A	17 1/2"	N/A	15 1/8"	N/A	23 3/16"	N/A	20 15/16"	77"	4	74"	4	38"	19		
	234" (233.04")	24"	78"	42"	86 13/16"	N/A	17 1/2"	N/A	15 1/8"	N/A	23 3/16"	N/A	20 15/16"	80"	5	77"	4	39"	19 1/2"		
	240" (239.04")	24"	80"	42"	89 13/16"	N/A	17 1/2"	N/A	15 1/8"	N/A	23 3/16"	N/A	20 15/16"	83"	5	80"	5	40"	20"		
	246" (245.04")	24"	82"	42"	92 13/16"	N/A	17 1/2"	N/A	15 1/8"	N/A	23 3/16"	N/A	20 15/16"	86"	5	83"	5	41"	20 1/2"		
	252" (251.04")	24"	84"	42"	95 13/16"	N/A	17 1/2"	N/A	15 1/8"	N/A	23 3/16"	N/A	20 15/16"	89"	5	86"	5	42"	21"		
	258" (257.04")	24"	86"	42"	98 13/16"	N/A	17 1/2"	N/A	15 1/8"	N/A	23 3/16"	N/A	20 15/16"	92"	5	89"	5	43"	21 1/2"		
	264" (263.04")	24"	88"	42"	101 13/16"	N/A	17 1/2"	N/A	15 1/8"	N/A	23 3/16"	N/A	20 15/16"	92"	6	92"	5	44"	22		
	270" (269.04")	24"	90"	42"	104 13/16"	N/A	17 1/2"	N/A	15 1/8"	N/A	23 3/16"	N/A	20 15/16"	98"	6	95"	6	45"	23 1/2"		
54" (53.68")	186" (185.04")	27"	62"	48"	62 13/16"	N/A	20 1/2"	N/A	18 1/8"	N/A	23 3/16"	N/A	20 15/16"	56"	3	53"	3	31"	15 1/2"		
	192" (191.04")	27"	64"	48"	65 13/16"	N/A	20 1/2"	N/A	18 1/8"	N/A	23 3/16"	N/A	20 15/16"	59"	3	56"	3	32"	16"		
	198" (197.04")	27"	66"	48"	68 13/16"	N/A	20 1/2"	N/A	18 1/8"	N/A	23 3/16"	N/A	20 15/16"	62"	3	59"	3	33"	16 1/2"		
	204" (203.04")	27"	68"	48"	71 13/16"	N/A	20 1/2"	N/A	18 1/8"	N/A	23 3/16"	N/A	20 15/16"	65"	3	62"	3	34"	17"		
	210" (219.04")	27"	70"	48"	74 13/16"	N/A	20 1/2"	N/A	18 1/8"	N/A	23 3/16"	N/A	20 15/16"	68"	4	65"	3	35"	17 1/2"		
	216" (215.04")	27"	72"	48"	77 13/16"	N/A	20 1/2"	N/A	18 1/8"	N/A	23 3/16"	N/A	20 15/16"	71"	4	68"	4	36"	18"		
	222" (221.04")	27"	74"	48"	80 13/16"	N/A	20 1/2"	N/A	18 1/8"	N/A	23 3/16"	N/A	20 15/16"	74"	4	71"	4	37"	18 1/2"		
	228" (227.04")	27"	76"	48"	83 13/16"	N/A	20 1/2"	N/A	18 1/8"	N/A	23 3/16"	N/A	20 15/16"	77"	4	74"	4	38"	19		
	234" (233.04")	27"	78"	48"	86 13/16"	N/A	20 1/2"	N/A	18 1/8"	N/A	23 3/16"	N/A	20 15/16"	80"	5	77"	4	39"	19 1/2"		
	240" (239.04")	27"	80"	48"	89 13/16"	N/A	20 1/2"	N/A	18 1/8"	N/A	23 3/16"	N/A	20 15/16"	83"	5	80"	5	40"	20"		
	246" (245.04")	27"	82"	48"	92 13/16"	N/A	20 1/2"	N/A	18 1/8"	N/A	23 3/16"	N/A	20 15/16"	86"	5	83"	5	41"	20 1/2"		
	252" (251.04")	27"	84"	48"	95 13/16"	N/A	20 1/2"	N/A	18 1/8"	N/A	23 3/16"	N/A	20 15/16"	89"	5	86"	5	42"	21"		
	258" (257.04")	27"	86"	48"	98 13/16"	N/A	20 1/2"	N/A	18 1/8"	N/A	23 3/16"	N/A	20 15/16"	92"	5	89"	5	43"	21 1/2"		
	264" (263.04")	27"	88"	48"	101 13/16"	N/A	20 1/2"	N/A	18 1/8"	N/A	23 3/16"	N/A	20 15/16"	92"	6	92"	5	44"	22		
	270" (269.04")	27"	90"	48"	104 13/16"	N/A	20 1/2"	N/A	18 1/8"	N/A	23 3/16"	N/A	20 15/16"	98"	6	95"	6	45"	23 1/2"		
60" (59.68")	186" (185.04")	30"	62"	54"	62 13/16"	N/A	23 1/2"	N/A	21 1/8"	N/A	23 3/16"	N/A	20 15/16"	56"	3	53"	3	31"	15 1/2"		
	192" (191.04")	30"	64"	54"	65 13/16"	N/A	23 1/2"	N/A	21 1/8"	N/A	23 3/16"	N/A	20 15/16"	59"	3	56"	3	32"	16"		
	198" (197.04")	30"	66"	54"	68 13/16"	N/A	23 1/2"	N/A	21 1/8"	N/A	23 3/16"	N/A	20 15/16"	62"	3	59"	3	33"	16 1/2"		
	204" (203.04")	30"	68"	54"	71 13/16"	N/A	23 1/2"	N/A	21 1/8"	N/A	23 3/16"	N/A	20 15/16"	65"	3	62"	3	34"	17"		
	210" (219.04")	30"	70"	54"	74 13/16"	N/A	23 1/2"	N/A	21 1/8"	N/A	23 3/16"	N/A	20 15/16"	68"	4	65"	3	35"	17 1/2"		
	216" (215.04")	30"	72"	54"	77 13/16"	N/A	23 1/2"	N/A	21 1/8"	N/A	23 3/16"	N/A	20 15/16"	71"	4	68"	4	36"	18"		
	222" (221.04")	30"	74"	54"	80 13/16"	N/A	23 1/2"	N/A	21 1/8"	N/A	23 3/16"	N/A	20 15/16"	74"	4	71"	4	37"	18 1/2"		
	228" (227.04")	30"	76"	54"	83 13/16"	N/A	23 1/2"	N/A	21 1/8"	N/A	23 3/16"	N/A	20 15/16"	77"	4	74"	4	38"	19		
	234" (233.04")	30"	78"	54"	86 13/16"	N/A	23 1/2"	N/A	21 1/8"	N/A	23 3/16"	N/A	20 15/16"	80"	5	77"	4	39"	19 1/2"		
	240" (239.04")	30"	80"	54"	89 13/16"	N/A	23 1/2"	N/A	21 1/8"	N/A	23 3/16"	N/A	20 15/16"	83"	5	80"	5	40"	20"		
	246" (245.04")	30"	82"	54"	92 13/16"	N/A	23 1/2"	N/A	21 1/8"	N/A	23 3/16"	N/A	20 15/16"	86"	5	83"	5	41"	20 1/2"		
	252" (251.04")	30"	84"	54"	95 13/16"	N/A	23 1/2"	N/A	21 1/8"	N/A	23 3/16"	N/A	20 15/16"	89"	5	86"	5	42"	21"		
	258" (257.04")	30"	86"	54"	98 13/16"	N/A	23 1/2"	N/A	21 1/8"	N/A	23 3/16"	N/A	20 15/16"	92"	5	89"	5	43"	21 1/2"		
	264" (263.04")	30"	88"	54"	101 13/16"	N/A	23 1/2"	N/A	21 1/8"	N/A	23 3/16"	N/A	20 15/16"	92"	6	92"	5	44"	22		
	270" (269.04")	30"	90"	54"	104 13/16"	N/A	23 1/2"	N/A	21 1/8"	N/A											

Product Details – Planes Conference Table Top (for use with Column Base)

Rectangle, Pebble and Hexagon (3-Piece Top) – Seating Capacity

Rectangle Top

- 186"-270" wide requires (3) separately specified Column Bases.

Rectangle Top

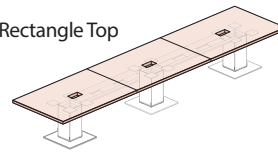

		WIDTHS							
		186" Wide	192" Wide	198" Wide	204" Wide	210" Wide	216" Wide	222" Wide	228" Wide
DEPTHS	42" Deep								
	48" Deep								
	54" Deep								
	60" Deep								

		WIDTHS						
		234" Wide	240" Wide	246" Wide	252" Wide	258" Wide	264" Wide	270" Wide
DEPTHS	42" Deep							
	48" Deep							
	54" Deep							
	60" Deep							

Note Recommended seating capacity based upon a width of 27" per chair.

Product Details – Planes Conference Table Top (for use with Column Base)

Rectangle, Pebble and Hexagon (3-Piece Top) – Seating Capacity

Pebble Top

- 186"-270" wide requires (3) separately specified Column Bases.

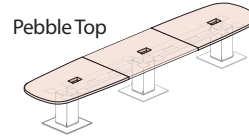

		WIDTHS							
		186" Wide	192" Wide	198" Wide	204" Wide	210" Wide	216" Wide	222" Wide	228" Wide
DEPTHS	42" Deep	14 Chairs Maximum (3 Columns)	16 Chairs Maximum (3 Columns)	16 Chairs Maximum (3 Columns)	16 Chairs Maximum (3 Columns)	16 Chairs Maximum (3 Columns)	18 Chairs Maximum (3 Columns)	18 Chairs Maximum (3 Columns)	18 Chairs Maximum (3 Columns)
	48" Deep	14 Chairs Maximum (3 Columns)	16 Chairs Maximum (3 Columns)	16 Chairs Maximum (3 Columns)	16 Chairs Maximum (3 Columns)	16 Chairs Maximum (3 Columns)	18 Chairs Maximum (3 Columns)	18 Chairs Maximum (3 Columns)	18 Chairs Maximum (3 Columns)
	54" Deep	14 Chairs Maximum (3 Columns)	16 Chairs Maximum (3 Columns)	16 Chairs Maximum (3 Columns)	16 Chairs Maximum (3 Columns)	16 Chairs Maximum (3 Columns)	18 Chairs Maximum (3 Columns)	18 Chairs Maximum (3 Columns)	18 Chairs Maximum (3 Columns)
	60" Deep	16 Chairs Maximum (3 Columns)	18 Chairs Maximum (3 Columns)	18 Chairs Maximum (3 Columns)	18 Chairs Maximum (3 Columns)	18 Chairs Maximum (3 Columns)	20 Chairs Maximum (3 Columns)	20 Chairs Maximum (3 Columns)	20 Chairs Maximum (3 Columns)

		WIDTHS						
		234" Wide	240" Wide	246" Wide	252" Wide	258" Wide	264" Wide	270" Wide
DEPTHS	42" Deep	18 Chairs Maximum (3 Columns)	18 Chairs Maximum (3 Columns)	20 Chairs Maximum (3 Columns)	20 Chairs Maximum (3 Columns)	20 Chairs Maximum (3 Columns)	20 Chairs Maximum (3 Columns)	22 Chairs Maximum (3 Columns)
	48" Deep	18 Chairs Maximum (3 Columns)	18 Chairs Maximum (3 Columns)	20 Chairs Maximum (3 Columns)	20 Chairs Maximum (3 Columns)	20 Chairs Maximum (3 Columns)	20 Chairs Maximum (3 Columns)	22 Chairs Maximum (3 Columns)
	54" Deep	18 Chairs Maximum (3 Columns)	18 Chairs Maximum (3 Columns)	20 Chairs Maximum (3 Columns)	20 Chairs Maximum (3 Columns)	20 Chairs Maximum (3 Columns)	20 Chairs Maximum (3 Columns)	22 Chairs Maximum (3 Columns)
	60" Deep	20 Chairs Maximum (3 Columns)	20 Chairs Maximum (3 Columns)	22 Chairs Maximum (3 Columns)	22 Chairs Maximum (3 Columns)	22 Chairs Maximum (3 Columns)	22 Chairs Maximum (3 Columns)	24 Chairs Maximum (3 Columns)

Note Recommended seating capacity based upon a width of 27" per chair.

Product Details – Planes Conference Table Top (for use with Column Base)

Rectangle, Pebble and Hexagon (3-Piece Top) – Seating Capacity

Hexagon Top

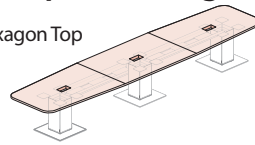

Hexagon Top

- 186"-270" wide requires (3) separately specified Column Bases.

		WIDTHS							
		186" Wide	192" Wide	198" Wide	204" Wide	210" Wide	216" Wide	222" Wide	228" Wide
DEPTHS	42" Deep	14 Chairs Maximum (3 Columns)	16 Chairs Maximum (3 Columns)	16 Chairs Maximum (3 Columns)	16 Chairs Maximum (3 Columns)	16 Chairs Maximum (3 Columns)	18 Chairs Maximum (3 Columns)	18 Chairs Maximum (3 Columns)	18 Chairs Maximum (3 Columns)
	48" Deep	14 Chairs Maximum (3 Columns)	16 Chairs Maximum (3 Columns)	16 Chairs Maximum (3 Columns)	16 Chairs Maximum (3 Columns)	16 Chairs Maximum (3 Columns)	18 Chairs Maximum (3 Columns)	18 Chairs Maximum (3 Columns)	18 Chairs Maximum (3 Columns)
	54" Deep	14 Chairs Maximum (3 Columns)	16 Chairs Maximum (3 Columns)	16 Chairs Maximum (3 Columns)	16 Chairs Maximum (3 Columns)	16 Chairs Maximum (3 Columns)	18 Chairs Maximum (3 Columns)	18 Chairs Maximum (3 Columns)	18 Chairs Maximum (3 Columns)
	60" Deep	16 Chairs Maximum (3 Columns)	18 Chairs Maximum (3 Columns)	18 Chairs Maximum (3 Columns)	18 Chairs Maximum (3 Columns)	18 Chairs Maximum (3 Columns)	20 Chairs Maximum (3 Columns)	20 Chairs Maximum (3 Columns)	20 Chairs Maximum (3 Columns)

		WIDTHS						
		234" Wide	240" Wide	246" Wide	252" Wide	258" Wide	264" Wide	270" Wide
DEPTHS	42" Deep	18 Chairs Maximum (3 Columns)	18 Chairs Maximum (3 Columns)	20 Chairs Maximum (3 Columns)	20 Chairs Maximum (3 Columns)	20 Chairs Maximum (3 Columns)	20 Chairs Maximum (3 Columns)	22 Chairs Maximum (3 Columns)
	48" Deep	18 Chairs Maximum (3 Columns)	18 Chairs Maximum (3 Columns)	20 Chairs Maximum (3 Columns)	20 Chairs Maximum (3 Columns)	20 Chairs Maximum (3 Columns)	20 Chairs Maximum (3 Columns)	22 Chairs Maximum (3 Columns)
	54" Deep	18 Chairs Maximum (3 Columns)	18 Chairs Maximum (3 Columns)	20 Chairs Maximum (3 Columns)	20 Chairs Maximum (3 Columns)	20 Chairs Maximum (3 Columns)	20 Chairs Maximum (3 Columns)	22 Chairs Maximum (3 Columns)
	60" Deep	20 Chairs Maximum (3 Columns)	20 Chairs Maximum (3 Columns)	22 Chairs Maximum (3 Columns)	22 Chairs Maximum (3 Columns)	22 Chairs Maximum (3 Columns)	22 Chairs Maximum (3 Columns)	24 Chairs Maximum (3 Columns)

Note Recommended seating capacity based upon a width of 27" per chair.

Product Details – Planes Conference Table Top (for use with Column Base)

Rectangle, Pebble and Hexagon (3-Piece Top) – Floor Support Requirements

- 3-Piece Rectangle, Pebble and Hexagon Tops require a separately specified J Channel and Column Bases.
- 186"-270" wide 3-Piece Tops require (3) separately specified Column Bases.
- A Column Base is comprised of a separately specified Column Frame, Column Base Plate and Cladding.

Column Frame with Square Column Base Plate Specification Matrix

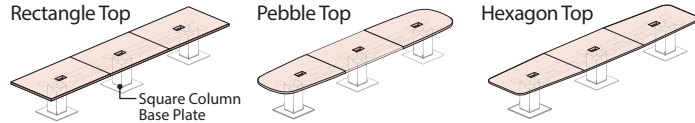

TABLE TOP DEPTH (Rectangle, Pebble or Hexagon)	COLUMN FRAME/COLUMN BASE SIZE COMBINATIONS				
	9" x 9" Column Frame		12" x 12" Column Frame		
	21" Square Base Plate	24" Square Base Plate	24" Square Base Plate	27" Square Base Plate	30" Square Base Plate
	⊘ Don't				
42" Deep Tops	⊘ Don't				
48" Deep Tops	⊘ Don't	⊘ Don't	⊘ Don't		
54" Deep Tops	⊘ Don't	⊘ Don't	⊘ Don't		
60" Deep Tops	⊘ Don't	⊘ Don't	⊘ Don't		

Column Frame with Round Column Base Plate Specification Matrix

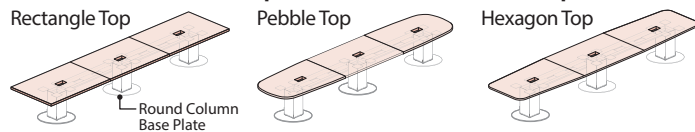

TABLE TOP DEPTH (Rectangle, Pebble or Hexagon)	COLUMN FRAME/COLUMN BASE SIZE COMBINATIONS				
	9" x 9" Column Frame		12" x 12" Column Frame		
	21" Round Base Plate	24" Round Base Plate	24" Round Base Plate	27" Round Base Plate	30" Round Base Plate
	⊘ Don't				
42" Deep Tops	⊘ Don't				
48" Deep Tops	⊘ Don't	⊘ Don't	⊘ Don't		
54" Deep Tops	⊘ Don't	⊘ Don't	⊘ Don't		
60" Deep Tops	⊘ Don't	⊘ Don't	⊘ Don't		

Note • Double-Sided Flip Top Units cannot be placed over the 9" Column Frame.

Product Details – Planes End Supported Top (for use with Column Bases)

Overview

The End Supported Top is designed to be supported on one end with a Cable Column Assembly and on the other end with brackets that attached to a structural wall, an Enclose Wall or a Compose Panel. To specify an End supported Table select a top from wide variety of sizes and shapes, next combine it with a column base assembly to support the top in a range of heights, finally select the appropriate attachment bracket for each application.

Table Components (Exploded View)

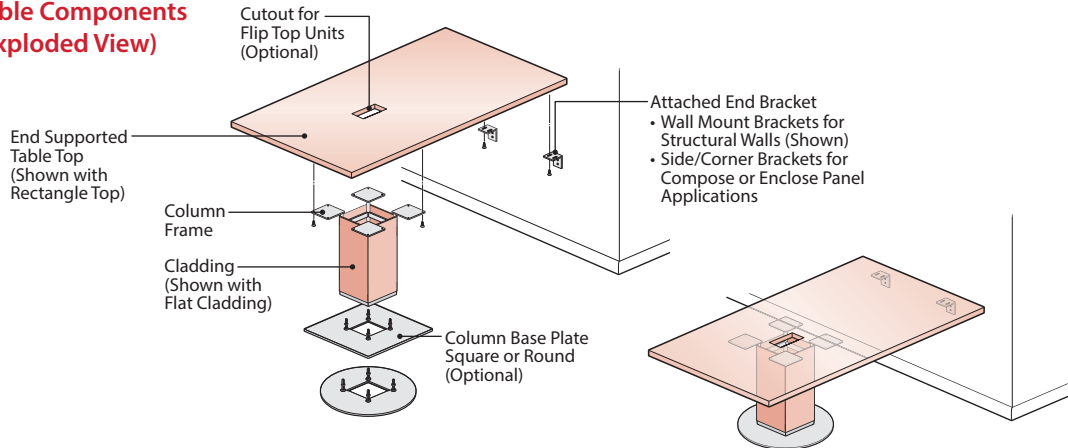

Steps to Specifying a Conference Table with Cable Base

Step 1 | End Supported Top

- Select desired top size and shape.
- Choose from rectangle, D-shape or Key shaped tops (always 1-piece top).

Step 2 | Floor Support – Column Base Assembly/Attached End Bracket

- End Supported Tables require a Column Base Assembly for floor support on one end and brackets for attachment to a structural building wall, Compose or Enclose panel on the other end.

A. Column Frame

- Column Frames are square and are available in two sizes, 9" and 12" square, and three heights, 20" lounge height, 28" seated height and 40" standing height.
 - One Column Frame is required per End Supported Top.
 - The table top depth dictates the column frame size, 9" or 12" square.

B. Column Base Plate (Optional)

- Column Base Plate is an optional component for an End Support Top. (Note: Required for a Conference Table with Column Base)
- Round or Square Column Base Plates are available in four sizes: 21", 24", 27" and 30".
- The column base plate size is specific to the column frame size of 9" or 12"; specify accordingly.
- The column frame width and the table top depth dictate the size of the column base plate.

C. Cladding

- Round or Flat Cladding is available in two widths, 9" & 12", and three heights, 20" lounge height, 28" seated height and 40" standing height. (Exception: Round cladding is not available 40" high)
 - Cladding is specified as one single piece per catalog number. A quantity of (4) pieces are required per each Column Frame.
 - Note: All round or flat, or a combination of round and flat cladding may be used on a column frame.
 - Specify cladding to match the column frame width and height.

Note J-Channel and J-Channel Tray are not required for an End Supported Top.

Product Details – Planes End Supported Top (for use with Column Bases)

D-Shape Convergent, Rectangle and Key Conference Tops

D-Shape Convergent

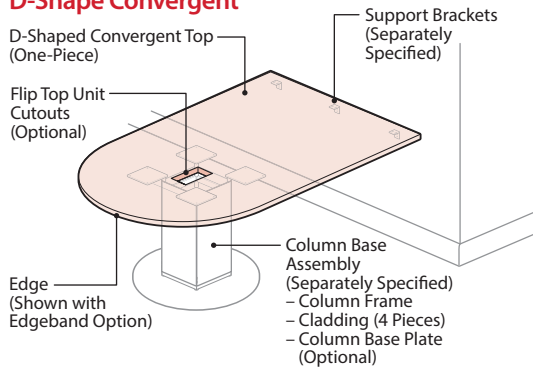

Rectangle Conference Top

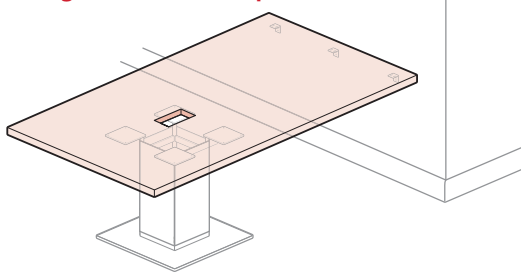

Key Conference Top

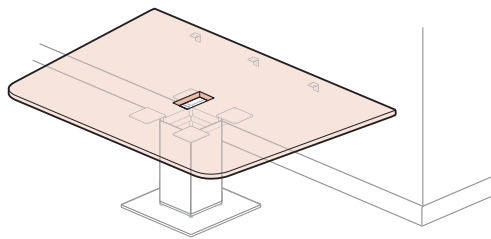

Separately Specified Components

- End Supported Tops require a separately specified Column Base on user end and support brackets for wall mounted end.

Column Base

- A Column Base is comprised of a separately specified Column Frame and Cladding. Optional Column Base Plate may also be specified.
- Column Frames are available with 20", 28" and 40" heights.

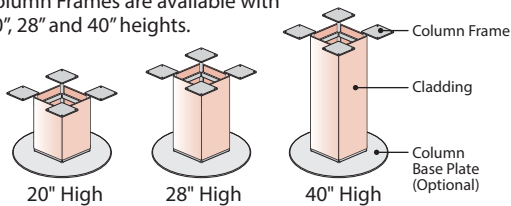

Support Brackets

- Support brackets for attachment to the building wall or support brackets for Enclose or Compose.

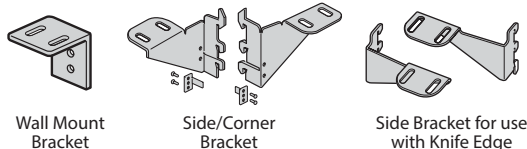

Component Materials/Finishes

COMPONENT NAME	MATERIALS/ FINISHES
End Supported Top – D-Shape, Rectangle, Key	Laminate Top – Specified top color and specified edge trim color • Edge Options: (J) Edgeband, (F) Knife • 1mm edgeband on wall mounted edge.
	Wood Top – Specified top and edge trim wood finish color • Edge Options: (K) Edgeband, (U) Knife • 1mm edgeband on wall mounted edge.

Edge Options for Laminate Tops

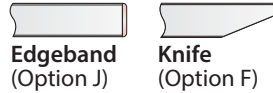

Edge Options for Wood Tops

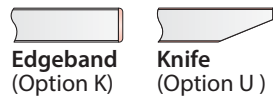

Note The specified edge option is applied only to the user edges, the wall mounted edge is standard with 1mm Edgeband.

Flip Top Unit Cutout Options

Center Cutout Option

- Includes 1 Flip Top Unit Cutout (centered on top)

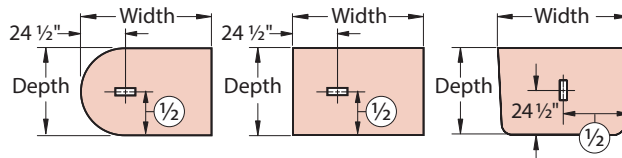

Flip Top Unit Cutout Dimensions

Cutout Option (F)

- For use with Single Sided/ 4 Port Flip Top Unit (Centered)

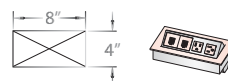

Cutout Option (J)

- For use with Single Sided/ 6 Ports Flip Top Unit (Centered)

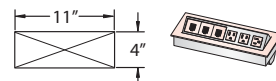

Cutout Option (M)

- For use with Double Sided/ 8 Ports Flip Top Unit (Centered)

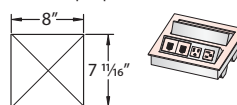

Cutout Option (Q)

- For use with Double Sided/ 12 Ports Flip Top Unit (Centered)

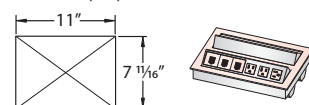

workware Interface Module Cutout Dimensions

Cutout Option (D)

- For use with workware 4 Port Narrow Non-Switching Interface Module (Centered)

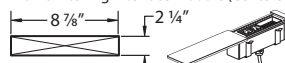

Cutout Option (W)

- For use with workware 4 Port Wide Non-Switching Interface Module (Centered)

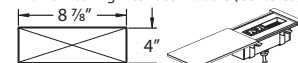

Cutout Option (C)

- For use with:
 - workware 6 Port Narrow Non-Switching Interface Module (Centered)
 - workware 4 Port Narrow Switching Interface Module (Centered)

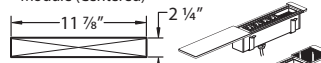

Cutout Option (H)

- For use with:
 - workware 6 Port Wide Non-Switching Interface Module (Centered)
 - workware 4 Port Wide Switching Interface Module (Centered)

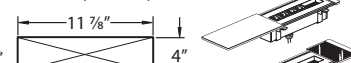

Cutout Option (E)

- For use with workware 6 Port Narrow Switching Interface Module (Centered)

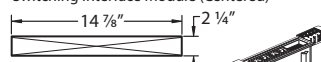

Cutout Option (L)

- For use with workware 6 Port Wide Switching Interface Module (Centered)



Note Flip Top Units and Interface Modules are all separately specified.

Product Details – Planes End Supported Top (for use with Column Bases)

D-Shape Convergent, Rectangle and Key Conference Tops – Dimensions

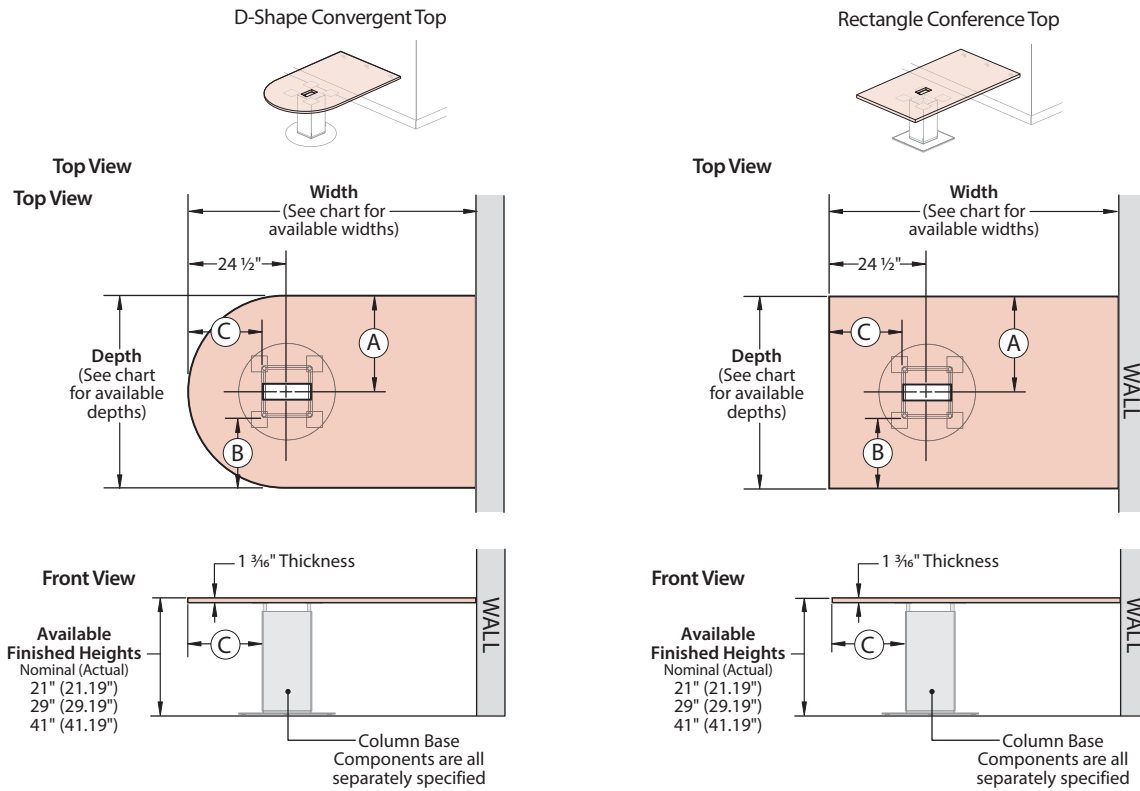

Dimensions

TABLE TOP			KNEESPACE							
Depth Nominal (Actual)	Width Nominal (Actual)	A	B				C			
			Flat Cladding		Round Cladding		Flat Cladding		Round Cladding	
			9" x 9" Column Frames	12" x 12" Column Frames	9" x 9" Column Frames	12" x 12" Column Frames	9" x 9" Column Frames	12" x 12" Column Frames	9" x 9" Column Frames	12" x 12" Column Frames
36" (35.68") (Only available with the Rectangle Top)	48" (47.68")	18"	13"	11 1/2"	11 1/4"	9 1/8"	19 5/8"	18 1/8"	17.91"	15.77"
	54" (53.68")	18"	13"	11 1/2"	11 1/4"	9 1/8"	19 5/8"	18 1/8"	17.91"	15.77"
	60" (59.68")	18"	13"	11 1/2"	11 1/4"	9 1/8"	19 5/8"	18 1/8"	17.91"	15.77"
	66" (65.68")	18"	13"	11 1/2"	11 1/4"	9 1/8"	19 5/8"	18 1/8"	17.91"	15.77"
	72" (71.68")	18"	13"	11 1/2"	11 1/4"	9 1/8"	19 5/8"	18 1/8"	17.91"	15.77"
42" (41.68")	48" (47.68")	21"	16"	14 1/2"	14 1/4"	12 1/8"	19 5/8"	18 1/8"	17.91"	15.77"
	54" (53.68")	21"	16"	14 1/2"	14 1/4"	12 1/8"	19 5/8"	18 1/8"	17.91"	15.77"
	60" (59.68")	21"	16"	14 1/2"	14 1/4"	12 1/8"	19 5/8"	18 1/8"	17.91"	15.77"
	66" (65.68")	21"	16"	14 1/2"	14 1/4"	12 1/8"	19 5/8"	18 1/8"	17.91"	15.77"
	72" (71.68")	21"	16"	14 1/2"	14 1/4"	12 1/8"	19 5/8"	18 1/8"	17.91"	15.77"
48" (47.68")	48" (47.68")	24"	N/A	17 1/2"	N/A	15 1/8"	N/A	18 1/8"	N/A	15.77"
	54" (53.68")	24"	N/A	17 1/2"	N/A	15 1/8"	N/A	18 1/8"	N/A	15.77"
	60" (59.68")	24"	N/A	17 1/2"	N/A	15 1/8"	N/A	18 1/8"	N/A	15.77"
	66" (65.68")	24"	N/A	17 1/2"	N/A	15 1/8"	N/A	18 1/8"	N/A	15.77"
	72" (71.68")	24"	N/A	17 1/2"	N/A	15 1/8"	N/A	18 1/8"	N/A	15.77"
54" (53.68")	54" (53.68")	27"	N/A	20 1/2"	N/A	18 1/8"	N/A	18 1/8"	N/A	15.77"
	60" (59.68")	27"	N/A	20 1/2"	N/A	18 1/8"	N/A	18 1/8"	N/A	15.77"
	66" (65.68")	27"	N/A	20 1/2"	N/A	18 1/8"	N/A	18 1/8"	N/A	15.77"
	72" (71.68")	27"	N/A	20 1/2"	N/A	18 1/8"	N/A	18 1/8"	N/A	15.77"
	60" (59.68")	60" (59.68")	30"	N/A	23 1/2"	N/A	21 1/8"	N/A	18 1/8"	N/A
66" (65.68")		30"	N/A	23 1/2"	N/A	21 1/8"	N/A	18 1/8"	N/A	15.77"
72" (71.68")		30"	N/A	23 1/2"	N/A	21 1/8"	N/A	18 1/8"	N/A	15.77"
78" (77.68")		30"	N/A	23 1/2"	N/A	21 1/8"	N/A	18 1/8"	N/A	15.77"
84" (83.68")		30"	N/A	23 1/2"	N/A	21 1/8"	N/A	18 1/8"	N/A	15.77"

Product Details – Planes End Supported Top (for use with Column Bases)

D-Shape Convergent, Rectangle and Key Conference Tops – Dimensions

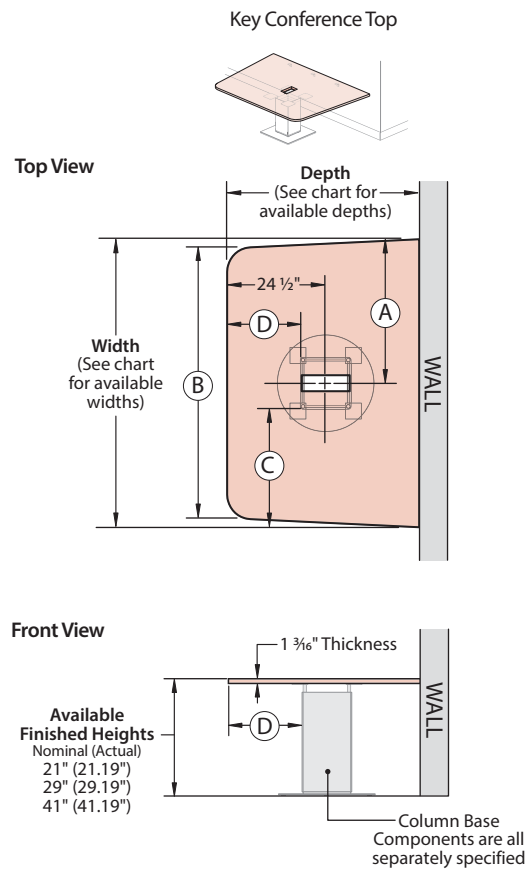

Dimensions

TABLE TOP				KNEESPACE							
Depth Nominal (Actual)	Width Nominal (Actual)	A	B	C				D			
				Flat Cladding		Round Cladding		Flat Cladding		Round Cladding	
				9" x 9" Column Frames	12" x 12" Column Frames	9" x 9" Column Frames	12" x 12" Column Frames	9" x 9" Column Frames	12" x 12" Column Frames	9" x 9" Column Frames	12" x 12" Column Frames
42" (41.68")	42" (41.68")	21"	38"	15.97"	14.47"	16.25"	12.11"	19.63"	18.13"	17.91"	15.77"
	48" (47.68")	21"	38"	18.97"	17.47"	19.25"	15.11"	19.63"	18.13"	17.91"	15.77"
	54" (53.68")	21"	38"	21.97"	20.47"	20.25"	18.11"	19.63"	18.13"	17.91"	15.77"
	60" (59.68")	21"	38"	24.97"	23.47"	23.25"	21.11"	19.63"	18.13"	17.91"	15.77"
48" (47.68")	48" (47.68")	24"	44"	N/A	17.47"	N/A	15.11"	N/A	18.13"	N/A	15.77"
	54" (53.68")	24"	44"	N/A	20.47"	N/A	18.11"	N/A	18.13"	N/A	15.77"
	60" (59.68")	24"	44"	N/A	23.47"	N/A	21.11"	N/A	18.13"	N/A	15.77"
	66" (65.68")	24"	44"	N/A	26.47"	N/A	24.11"	N/A	18.13"	N/A	15.77"
	72" (71.68")	24"	44"	N/A	29.47"	N/A	27.11"	N/A	18.13"	N/A	15.77"
54" (53.68")	54" (53.68")	27"	50"	N/A	20.47"	N/A	18.11"	N/A	18.13"	N/A	15.77"
	60" (59.68")	27"	50"	N/A	23.47"	N/A	21.11"	N/A	18.13"	N/A	15.77"
	66" (65.68")	27"	50"	N/A	26.47"	N/A	24.11"	N/A	18.13"	N/A	15.77"
	72" (71.68")	27"	50"	N/A	29.47"	N/A	27.11"	N/A	18.13"	N/A	15.77"
60" (59.68")	60" (59.68")	30"	56"	N/A	23.47"	N/A	21.11"	N/A	18.13"	N/A	15.77"
	66" (65.68")	30"	56"	N/A	26.47"	N/A	24.11"	N/A	18.13"	N/A	15.77"
	72" (71.68")	30"	56"	N/A	29.47"	N/A	27.11"	N/A	18.13"	N/A	15.77"
	78" (77.68")	30"	56"	N/A	32.47"	N/A	30.11"	N/A	18.13"	N/A	15.77"
	84" (83.68")	30"	56"	N/A	35.47"	N/A	33.11"	N/A	18.13"	N/A	15.77"

Product Details – Planes End Supported Top (for use with Column Bases)

D-Shape Convergent, Rectangle and Key Conference Tops – Seating Capacity

D-Shape Convergent

D-Shape Convergent Top

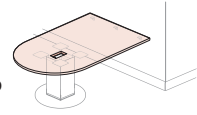

		WIDTHS						
		48" Wide	54" Wide	60" Wide	66" Wide	72" Wide	78" Wide	84" Wide
DEPTHS	42" Deep						N/A	N/A
	48" Deep						N/A	N/A
	54" Deep	N/A					N/A	N/A
	60" Deep	N/A	N/A					

Rectangle Conference Top

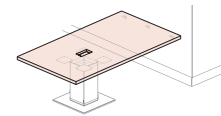

Rectangle

		WIDTHS						
		48" Wide	54" Wide	60" Wide	66" Wide	72" Wide	78" Wide	84" Wide
DEPTHS	36" Deep						N/A	N/A
	42" Deep						N/A	N/A
	48" Deep						N/A	N/A
	54" Deep	N/A					N/A	N/A
	60" Deep	N/A	N/A					

Note Recommended seating capacity based upon a width of 27" per chair.

Product Details – Planes End Supported Top (for use with Column Bases)

D-Shape Convergent, Rectangle and Key Conference Tops – Seating Capacity

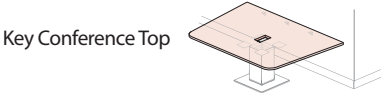

Key Conference Top

		WIDTHS							
		42" Wide	48" Wide	54" Wide	60" Wide	66" Wide	72" Wide	78" Wide	84" Wide
DEPTHS	42" Deep	3 Chairs Maximum	3 Chairs Maximum	3 Chairs Maximum	4 Chairs Maximum	N/A	N/A	N/A	N/A
	48" Deep	N/A	3 Chairs Maximum	3 Chairs Maximum	4 Chairs Maximum	4 Chairs Maximum	4 Chairs Maximum	N/A	N/A
	54" Deep	N/A	N/A	5 Chairs Maximum	6 Chairs Maximum	6 Chairs Maximum	6 Chairs Maximum	N/A	N/A
	60" Deep	N/A	N/A	N/A	6 Chairs Maximum	6 Chairs Maximum	6 Chairs Maximum	6 Chairs Maximum	7 Chairs Maximum

Note Recommended seating capacity based upon a width of 27" per chair.

Product Details – Planes End Supported Top (for use with Column Bases)

D-Shape Convergent, Rectangle and Key Conference Tops – Floor Support Requirements

- Requires one column base for floor support and brackets for attachment to a structural building wall, Compose or Enclose panel.
- Each Column Base requires separately specified components: Column Frame and Cladding (The Column Base Plate is optional).

Column Frame with Square Column Base Plate Specification Matrix

TABLE TOP DEPTH (Rectangle, Pebble or Hexagon)	COLUMN FRAME/COLUMN BASE PLATE SIZE COMBINATIONS				
	9" x 9" Column Frame		12" x 12" Column Frame		
	21" Square Base Plate	24" Square Base Plate	24" Square Base Plate	27" Square Base Plate	30" Square Base Plate
36" Deep Tops					
42" Deep Tops					
48" Deep Tops	⊘ Don't	⊘ Don't	⊘ Don't		
54" Deep Tops	⊘ Don't	⊘ Don't	⊘ Don't		
60" Deep Tops	⊘ Don't	⊘ Don't	⊘ Don't		

Rectangle Conference Top

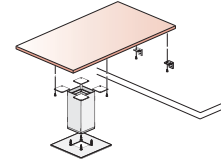

Square Column Base Plate (Optional)

Column Frame with Square Column Base Plate Specification Matrix

TABLE TOP DEPTH (Rectangle, Pebble or Hexagon)	COLUMN FRAME/COLUMN BASE PLATE SIZE COMBINATIONS				
	9" x 9" Column Frame		12" x 12" Column Frame		
	21" Round Base Plate	24" Round Base Plate	24" Round Base Plate	27" Round Base Plate	30" Round Base Plate
36" Deep Tops					
42" Deep Tops					
48" Deep Tops	⊘ Don't	⊘ Don't	⊘ Don't		
54" Deep Tops	⊘ Don't	⊘ Don't	⊘ Don't		
60" Deep Tops	⊘ Don't	⊘ Don't	⊘ Don't		

Rectangle Conference Top

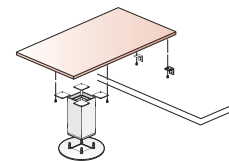

Round Column Base Plate (Optional)

- Note**
- J-Channel and J-Channel Tray are not required for End Supported Tops.
 - Double-Sided Flip Top Units cannot be placed over the 9" Column Frame.

Product Details – Planes End Supported Top (for use with Column Bases)

D-Shape Convergent, Rectangle and Key Conference Tops – Floor Support Requirements

- Requires one column base for floor support and brackets for attachment to a structural building wall, Compose or Enclose panel.
- Each Column Base requires separately specified components: Column Frame and Cladding (The Column Base Plate is optional).

Column Frame with Square Column Base Plate Specification Matrix

TABLE TOP DEPTH (Rectangle, Pebble or Hexagon)	COLUMN FRAME/COLUMN BASE PLATE SIZE COMBINATIONS				
	9" x 9" Column Frame		12" x 12" Column Frame		
	21" Square Base Plate	24" Square Base Plate	24" Square Base Plate	27" Square Base Plate	30" Square Base Plate
42" Deep Tops					
48" Deep Tops	⊘ Don't	⊘ Don't	⊘ Don't		
54" Deep Tops	⊘ Don't	⊘ Don't	⊘ Don't		
60" Deep Tops	⊘ Don't	⊘ Don't	⊘ Don't		

D-Shaped Convergent Top

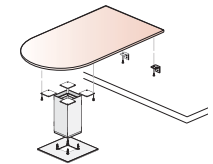

Square Column Base Plate (Optional)

Column Frame with Square Column Base Plate Specification Matrix

TABLE TOP DEPTH (Rectangle, Pebble or Hexagon)	COLUMN FRAME/COLUMN BASE PLATE SIZE COMBINATIONS				
	9" x 9" Column Frame		12" x 12" Column Frame		
	21" Round Base Plate	24" Round Base Plate	24" Round Base Plate	27" Round Base Plate	30" Round Base Plate
42" Deep Tops					
48" Deep Tops	⊘ Don't	⊘ Don't	⊘ Don't		
54" Deep Tops	⊘ Don't	⊘ Don't	⊘ Don't		
60" Deep Tops	⊘ Don't	⊘ Don't	⊘ Don't		

D-Shaped Convergent Top

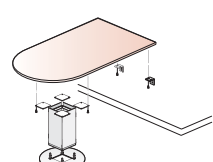

Round Column Base Plate (Optional)

- Note**
- J-Channel and J-Channel Tray are not required for an End Supported Tops.
 - Double-Sided Flip Top Units cannot be placed over the 9" Column Frame.

Product Details – Planes End Supported Top (for use with Column Bases)

D-Shape Convergent, Rectangle and Key Conference Tops – Floor Support Requirements

- End Supported Tops require one column base assembly for floor support and brackets for attachment to a structural building wall, Compose or Enclose panel.
- Each Column Base assembly requires separately specified components: Column Frame and Cladding (The Column Base Plate is optional).

Column Frame with Square Column Base Plate Specification Matrix

TABLE TOP DEPTH (Rectangle, Pebble or Hexagon)	COLUMN FRAME/COLUMN BASE PLATE SIZE COMBINATIONS				
	9" x 9" Column Frame		12" x 12" Column Frame		
	21" Square Base Plate	24" Square Base Plate	24" Square Base Plate	27" Square Base Plate	30" Square Base Plate
	⊘ Don't				
42" Deep Tops	⊘ Don't				
48" Deep Tops	⊘ Don't	⊘ Don't	⊘ Don't		
54" Deep Tops	⊘ Don't	⊘ Don't	⊘ Don't		
60" Deep Tops	⊘ Don't	⊘ Don't	⊘ Don't		

Key Conference Top

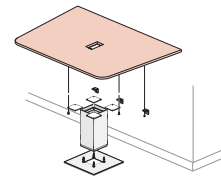

Square Column Base Plate (Optional)

Column Frame with Square Column Base Plate Specification Matrix

TABLE TOP DEPTH (Rectangle, Pebble or Hexagon)	COLUMN FRAME/COLUMN BASE PLATE SIZE COMBINATIONS				
	9" x 9" Column Frame		12" x 12" Column Frame		
	21" Round Base Plate	24" Round Base Plate	24" Round Base Plate	27" Round Base Plate	30" Round Base Plate
	⊘ Don't				
42" Deep Tops	⊘ Don't				
48" Deep Tops	⊘ Don't	⊘ Don't	⊘ Don't		
54" Deep Tops	⊘ Don't	⊘ Don't	⊘ Don't		
60" Deep Tops	⊘ Don't	⊘ Don't	⊘ Don't		

Key Conference Top

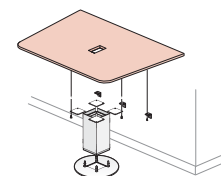

Round Column Base Plate (Optional)

- Note**
- J-Channel and J-Channel Tray are not required for an End Supported Tops.
 - Double-Sided Flip Top Units cannot be placed over the 9" Column Frame.

Product Details – Planes Column Base

Column Frame

- A Column Base assembly is composed of a separately specified Column Frame, a Column Base Plate and Cladding. (Exception: the Column Base Plate is optional when used with the End Supported Top)
- The Column Frame includes a square shaped frame, glides and mounting hardware.
- Specify Cladding and Column Base Plate to match size of the column frame.
- The quantity and width of the Column Frame is dependent on the size of the top.

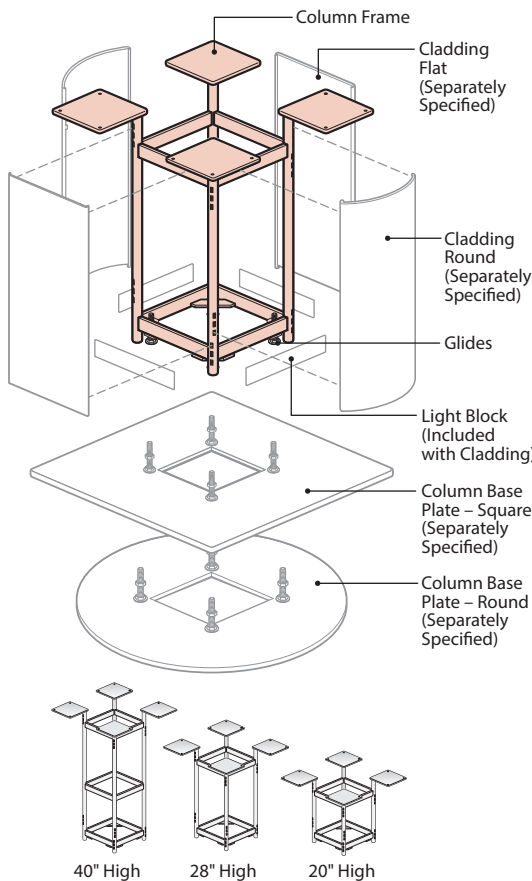

Component Materials/Finishes

COMPONENT NAME	MATERIALS/ FINISHES
Column Frame	Painted Metal – Standard in Black

Dimensions

Top View

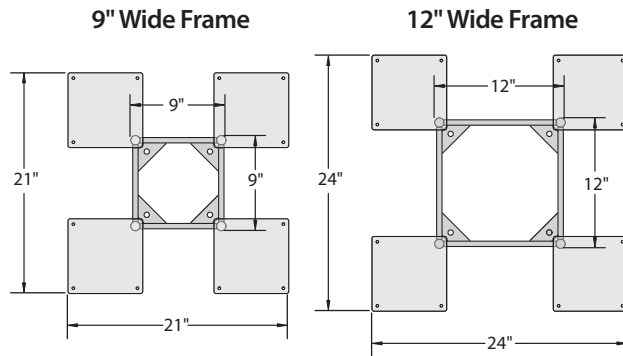

Front View

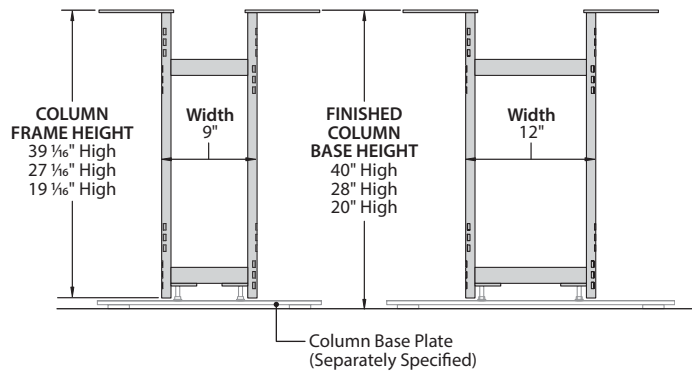

Note • Each Conference Table Top includes a Product Detail Page with Floor Support Requirements. Refer to these sections when specifying Column Base Frames to ensure proper floor support.

Column Frame Heights

- Column Frame is available in three heights: 40", 28" and 20" High.

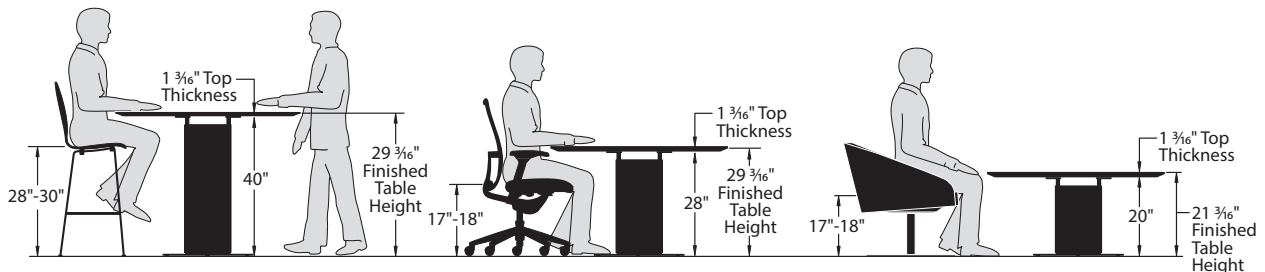

40" High Column Frame Height
(Bar Height/Standing Height)

- The 41 3/16" high table top is for use with most bar height seating (28"-30" seat heights) or standing applications.

28" High Column Frame Height
(Seated Height)

- The 21 3/16" high table top is for use with most standard seating (17"-18" seat heights).

20" High Column Frame Height
(Lounge Height)

- The 21 3/16" high table top is for use with most lounge seating (17"-18" seat heights).

Product Details – Planes Column Base

Cladding

A Column Base assembly is composed of a separately specified Column Frame, a Column Base Plate and Cladding. (Exception: the Column Base Plate is optional when used with the End Supported Top)

- Cladding includes one piece painted or wood veneer cladding and a light block.
- Attaches to Column Frame slots and is removable for easy access.
- Specify Cladding to match width and height of the Column Frame.

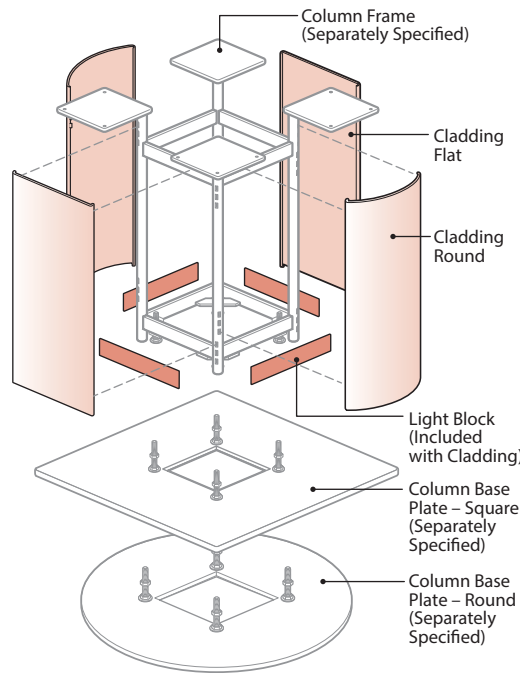

Cladding Applications

- Each Column Frame requires a quantity of four pieces of Cladding.
- Cladding can be flat, round or a combination of flat and round.

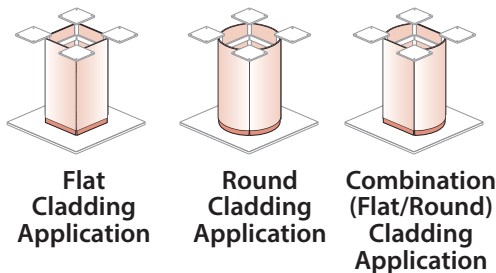

Component Materials/Finishes

COMPONENT NAME	MATERIALS/ FINISHES	
Cladding Flat or Round	Steel	Painted Finish – Select Surface Color
		Wood Veneer Finish– Select Wood Finish Color
Light Block	Plastic standard in black	

Dimensions

Top View

9" Wide Flat Cladding

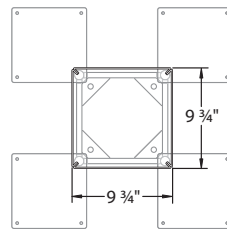

12" Wide Flat Cladding

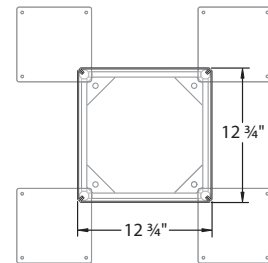

Front View

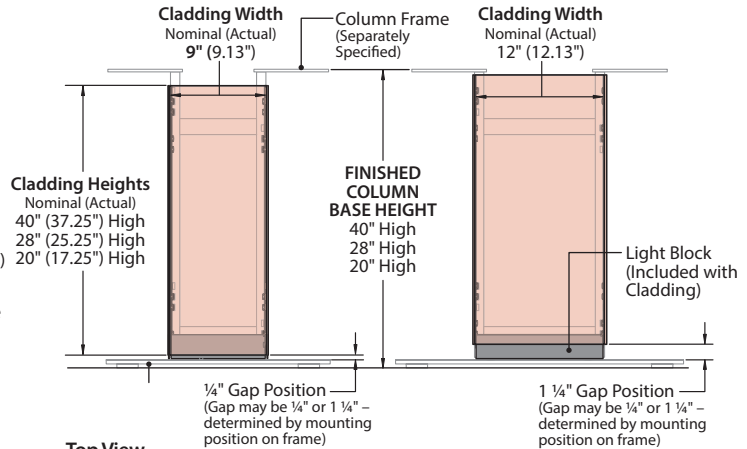

Top View

9" Wide Round Cladding

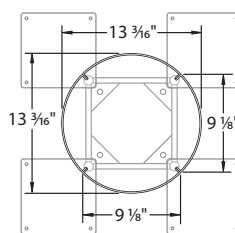

12" Wide Round Cladding

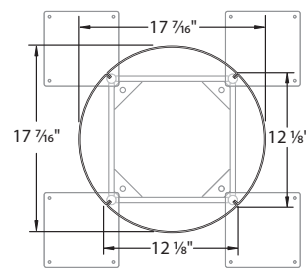

Front View

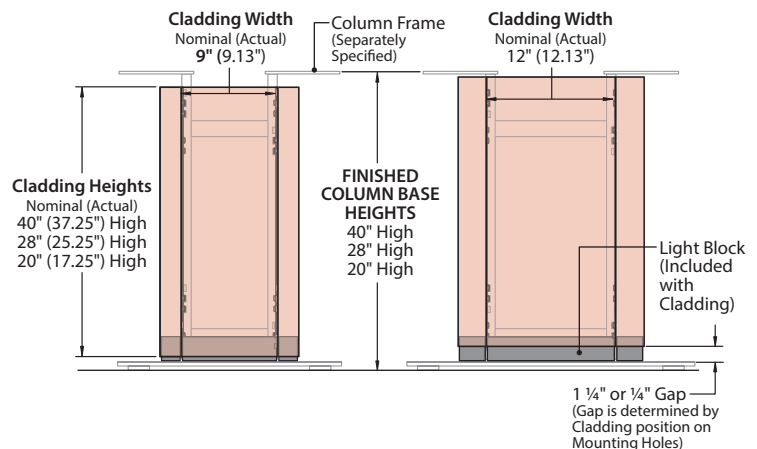

Product Details – Planes Column Base

Plate

A Column Base assembly is composed of a separately specified Column Frame, a Column Base Plate and Cladding. (Exception: the Column Base Plate is optional when used with the End Supported Top)

- The Column Base Plate includes a 3/8" thick plate with attached glides and is available in a round or square shape.
- The column base plate levels by adjusting the attachment hardware; 3/4" adjustment range.
- Column Base Plate is required for Planes Conference Table Tops and is optional for End Supported Top.
- Specify Column Base Plate size to meet the floor support requirements required for each top.
- Specify Column Base Plate to match size of the 12" or 9" wide column frame.
 - A Column Base Plate with an 8" x 8" cutout accepts a 12" column frame.
 - A Column Base Plate with a 6" x 6" cutout accepts a 9" column frame.

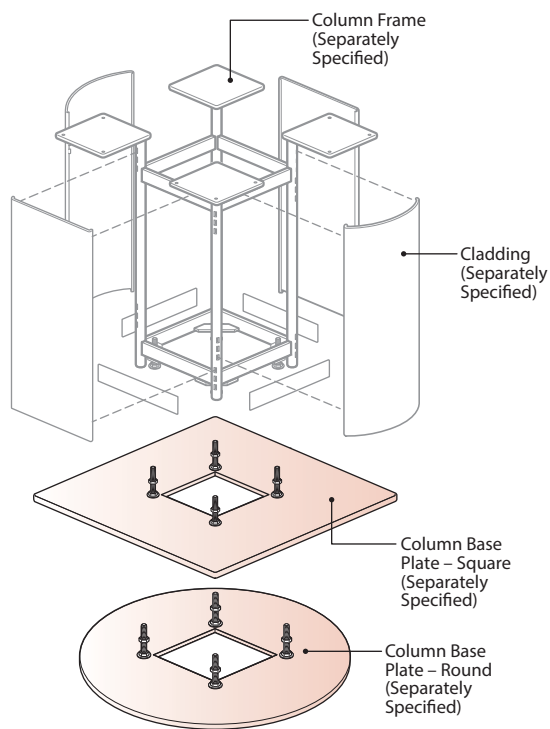

Note • Each Conference Table Top includes a Product Detail Page with Floor Support Requirements. Refer to these sections when specifying Column Base Plates to ensure proper floor support.

Component Materials/Finishes

COMPONENT NAME	MATERIALS/ FINISHES	
Column Base Plate	Steel	(A) Paint Finish – Select Paint Surface Color

Dimensions

Top View

Square – Column Base Plate

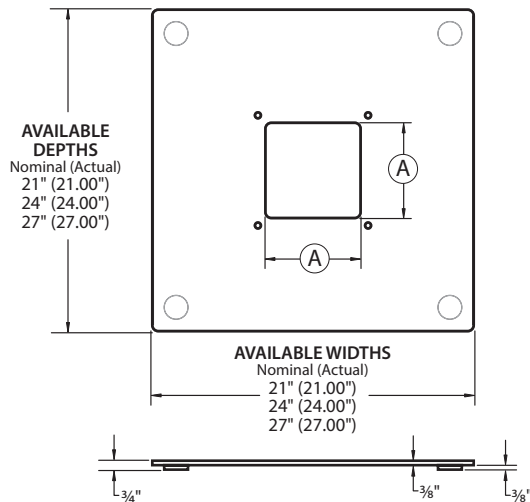

SQUARE PLATE		CUTOUT	COLUMN FRAME WIDTH
Depth Nominal (Actual)	Width Nominal (Actual)	(A)	Column Frame Width Requirement
21" (21.00")	21" (21.00")	6" Square Cutout	Requires 9" Wide Column Frame
24" (24.00")	24" (24.00")	6" Square Cutout	Requires 9" Wide Column Frame
		8" Square Cutout	Requires 12" Wide Column Frame
27" (27.00")	27" (27.00")	8" Square Cutout	Requires 12" Wide Column Frame

Round – Column Base Plate

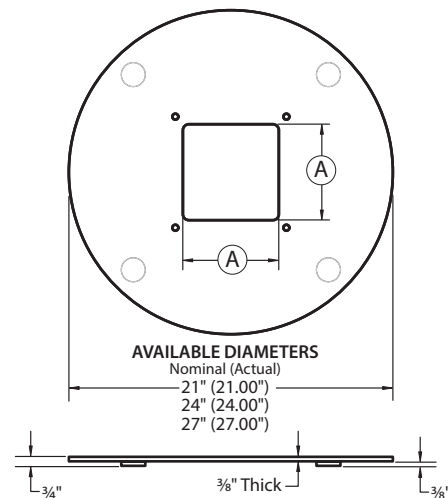

ROUND PLATE	CUTOUT	COLUMN FRAME WIDTH
Diameter (Round) Nominal (Actual)	(A)	Column Frame Size Requirements
21" (21.00")	6" Square Cutout	Requires 9" Wide Column Frame
24" (24.00")	6" Square Cutout	Requires 9" Wide Column Frame
	8" Square Cutout	Requires 12" Wide Column Frame
27" (27.00")	8" Square Cutout	Requires 12" Wide Column Frame
30" (30.00")	8" Square Cutout	Requires 12" Wide Column Frame

Product Details – Planes Column Base

J-Channels

J-Channels come in pairs and are mounted between Column Bases to provide support under large Conference Table Tops.

- May be used with separately specified J-Channel Trays to provide wire management.
- The Conference Table Top width and the Column Frame size determines the needed J-Channel width. (See the Product Detail Pages for each top to determine proper J-Channel width requirements.)
- J-Channels are not for use with End-Supported Tops or tops supported by a single Column Base.

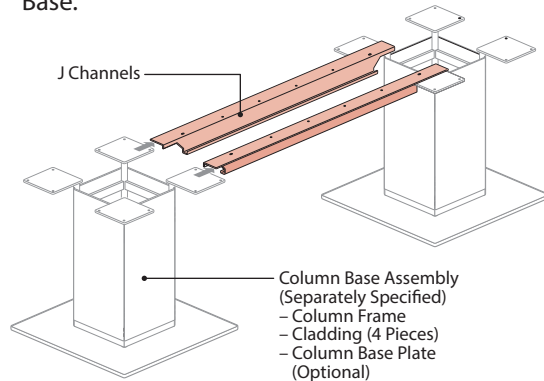

Component Materials/Finishes

COMPONENT NAME	MATERIALS/ FINISHES
Column Base Plate	Painted Steel – Standard in black finish.

Note • Each Conference Table Top includes a Product Detail Page which includes the required J-Channel Width for each specific Top. Refer to these sections to specify proper J-Channel width.

J-Channel – Conference Table Application

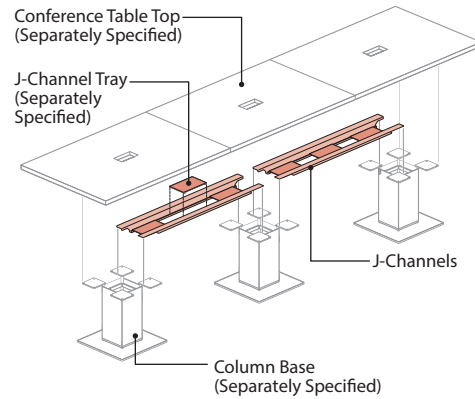

Dimensions

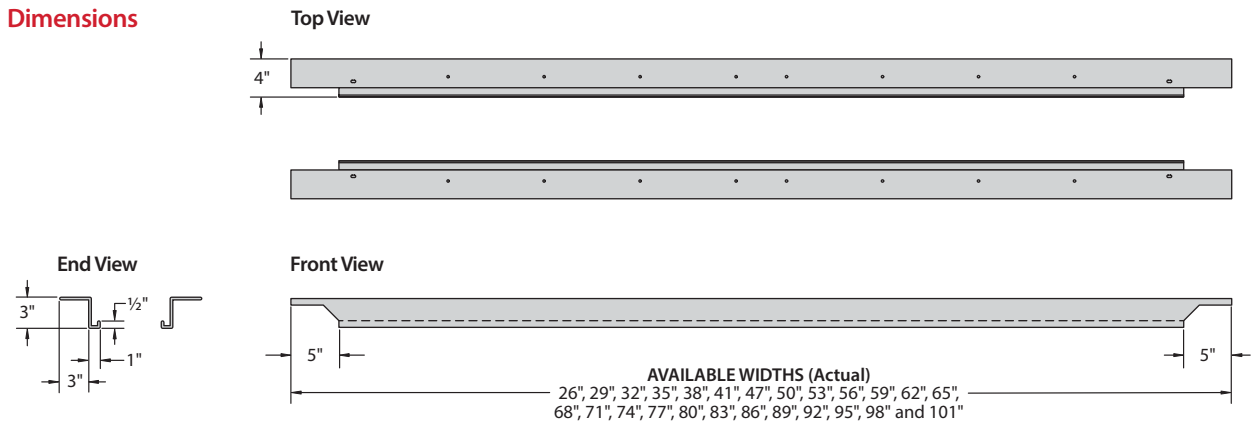

Column Base – J-Channel Tray

J-Channel Trays provides additional wire management between Column Bases; wires lay in J-Channels.

- Specify J-Channel Trays to match size of column frame width (12" or 9" wide).

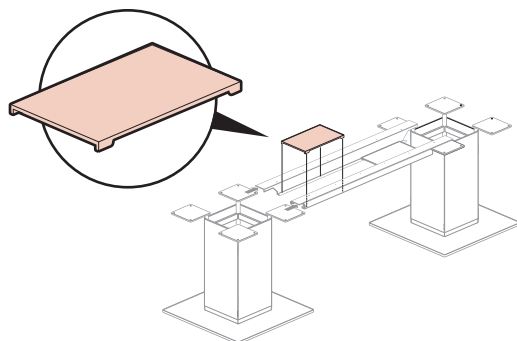

Component Materials/Finishes

COMPONENT NAME	MATERIALS/ FINISHES
J-Channel Tray	Painted Steel – Standard in black finish.

Note • Each Conference Table Top includes a Product Detail Page which includes the required J-Channel Width for each specific Top and quantity of J-Channel Trays needed. Refer to these sections to specify proper J-Channel Tray quantities.

Dimensions

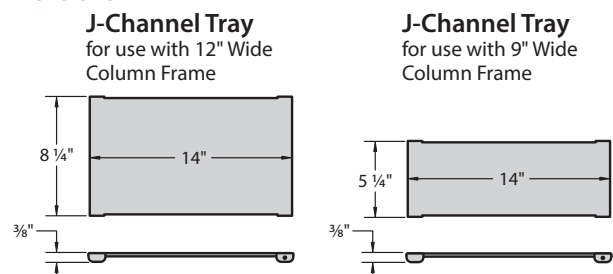

Specification Guide – Planes Tables

Technical Specifications Section

Technical Specifications – Planes Tables

Table Top Construction

Surface – Y-Leg Collaborative and C-Leg Training Tables – Laminate and Wood

Top Construction:

- Tops are 1.18" (30.2mm) thick made with a solid engineered composite wood. The composite wood is made with 100% recycled and/or recovered wood fiber bonded with resin. These materials are 3rd party certified compliant with CARB Phase 2 and EPA TSCA Title VI requirements for formaldehyde emissions. FSC™ Certification for composite wood materials are available.
- Top are 3rd party certified compliant by Greenguard, SCS Indoor Advantage, or Intertek Clean Air to ANSI/ BIFMA X-7.1 Standard for Formaldehyde and TVOC Emissions of Low-Emitting Office Furniture and Seating.

Edges for Laminate Tops:

- Edge options include 0.118" (3 mm) thick edgeband made of Acrylonitrile Butadiene Styrene (ABS); knife edge, constructed with 0.0118" (3 mm) thick edgeband that runs 0.375" (9.5 mm) down the perimeter of the edge before transitioning to a taper. Knife edges are on all sides of Collaborative tables while on Training tables they are on the user side only with 3mm edgeband on remaining edges to ensure flat seams.

Edges for Wood Tops:

- Edge options include 0.100" (2.5 mm) thick wood edgeband; knife edge, constructed with 0.100" (2.5 mm) edgeband that runs 0.375" (9.5 mm) down the perimeter of the edge before transitioning to a taper. Knife edges are on all sides of Collaborative tables while on Training tables they are on the user side only with 3mm edgeband on remaining edges to ensure flat seams.

Surface – Conference Tables, Interior Leg and Perimeter Leg - Laminate and Wood

Top Construction:

- Tops are 1.18" (30.2mm) thick made with a solid engineered composite wood. The composite wood is made with 100% recycled and/or recovered wood fiber bonded with resin. These materials are 3rd party certified compliant with CARB Phase 2 and EPA TSCA Title VI requirements for formaldehyde emissions. FSC™ Certification for composite wood materials are available.
- Top are 3rd party certified compliant by Greenguard, SCS Indoor Advantage, or Intertek Clean Air to ANSI/ BIFMA X-7.1 Standard for Formaldehyde and TVOC Emissions of Low-Emitting Office Furniture and Seating.

Edges for Laminate Tops:

- Interior Leg edge options include 0.118" (3 mm) thick edgeband made of Acrylonitrile Butadiene Styrene (ABS); knife edge, constructed with 0.0118" (3 mm) thick edgeband that runs 0.375" (9.5 mm) down the perimeter of the edge before transitioning to a taper. The Perimeter Leg edge option is 0.118" (3 mm) thick edgeband made of Acrylonitrile Butadiene Styrene (ABS). Multi-piece tops are constructed with a 0.039" (1 mm) thick plastic edgeband at the seam on Interior Leg tops and 0.118" (3 mm) thick edgeband on Perimeter Leg tops.

Edges for Wood Tops:

- Interior Leg edge options include 0.100" (2.5 mm) thick wood edgeband; knife edge, constructed with 0.100" (2.5 mm) edgeband that runs 0.375" (9.5 mm) down the perimeter of the edge before transitioning to a taper. The Perimeter Leg edge option is 0.100" (2.5 mm) thick wood edgeband. Multi-piece tops are constructed with a 0.039" (1 mm) thick plastic edgeband at the seam on Interior Leg tops and 0.118" (3 mm) thick edgeband on Perimeter Leg tops.

Table Base Construction

Y-Leg Collaborative and C-Leg Training Tables

Table Base Construction: Legs, connectors and stretcher are constructed of aluminum. Casters and glides are 3.15" (80 mm) high, and glides provide 0.5" (12.7 mm) height adjustment. Casters and glides are interchangeable without altering the height of the table. Flip top tables feature a gas-assist flip top mechanism with two finger pulls that release the top; non-flip top tables feature top support arms. Stretcher provides horizontal cable routing.

X and Disc Base Tables

X-Base Construction: Base is constructed of 2.25" diameter (57 mm) x 13-gauge steel tube welded to a .187" thick (4.7mm) steel top plate and is bolted to an aluminum four leg base. Base is optional with casters or glides (not interchangeable), glides have ½" (12.7 mm) adjustment. The base is available with either powdercoat paint or chrome finish.

Disc Base Construction: Base is constructed of a 3.0" diameter (76mm) x 13-gauge steel tube welded to a .179" thick (4.5mm) steel top plate and is bolted to a .375" thick (9.5mm) steel round disc base. The base is powder coat painted. Five (5) non-adjustable glides are attached to the bottom disc.

Technical Specifications – Planes Conference Tables

Table Base Construction (Continued)

Interior and Perimeter Leg Conference Tables

Conference Tables, Interior Leg Construction: Legs are extruded painted aluminum; glides on legs provide 0.5" (12.7 mm) vertical adjustment. Leg dimensions are 1.125" (28.6 mm) x 3.25" (83 mm).

Conference Tables, Perimeter Leg Construction: Legs are extruded painted aluminum; glides on legs provide 0.5" (12.7 mm) vertical adjustment. Leg dimensions are 1.375" (35 mm) x 4" (102 mm).

Cable Base Construction: The cable base for 36" (914 mm) deep tables are 8" (203 mm) x 14" (356 mm), and for tables deeper than 36" (914 mm), the cable base is 14" (356 mm) x 14" (356 mm). Base construction includes a 14-gauge steel frame with built-in brackets for cable management. The core consists of a 0.75" (19 mm) thick medium density fiberboard (mdf) that is finished with either 0.028" (.7 mm) thick laminate or 0.020" (.5 mm) thick veneer on both sides and 0.039" (1 mm) thick edgeband on exposed edges. The cable base provides 2.5" (64 mm) of cord access along the top of the panels facing the depth of the table that can be field adjusted for base access. Panels that face the length of the table are removable for access to the base. The 8" (203 mm) x 14" (356 mm) cable base bottom panel provides a 3" (76.2 mm) x 8" (203 mm) cutout, and 14" (356 mm) x 14" (356 mm) cable base provides an 8" (203 mm) x 8" (203 mm) cutout. Cable bases have leveling glides with 1" (25.4 mm) height adjustment.

Cable Column Construction: The Cable Column is 20-gauge steel, with a 14-gauge floor mount bracket and 12-gauge table mount bracket.

Column Base Conference Tables

Column Base: The column base frame consists of two sets (one at top and one at bottom) of four 16-gauge steel horizontal tubes welded to four 14-gauge steel vertical tubes to form a frame. Four .245 thick (6.2mm) steel top plates are welded to the top of the vertical tubes and four 0.250" thick (6.3mm) steel glide plates are welded to the bottom set of horizontal tubes. Frame is bolted to an optional .375" thick (9.5mm) round or square base plate with four non-adjustable glides. Base plate will have either a 6" (152 mm) x 6" (152 mm) or 8" (203 mm) x 8" (203 mm) cutout for routing of power and data cables. Attachment hardware allows for 0.75" (19mm) adjustment.

Column Base Cladding: Available with flat or round 18-gauge steel cladding which attach with hooks to column base for easy access. Cladding is available with painted or veneer finish.

Power and Data Systems

Flip Top Unit Detail: Corded and hardwire Flip Top Units are listed for U.S. and Canadian safety standards by Underwriters Laboratories, Inc. (UL & ULC). The Flip Top Units are available in single and double-sided configurations in data and electrical Port counts and sit flush with table top. A spring assist mechanism opens the top to provide access to electrical and data ports. Single-sided ports are fed with either a single, three (3) conductor 12' black 15-Amp cord with plug (NEMA 5-15P) or a hardwire version which consists of (3) 12 AWG wires enclosed within one 3/8" (9.5 mm) flexible metal conduit, 6' (1829 mm) in length. Double-sided units are fed with either a pair of three (3) conductor 12' (3658 mm) black 15-Amp cords with plug (NEMA 5-15P) or a hardwire version which consists of a pair of three (3) 12 AWG wires enclosed within one 3/8" flexible metal conduit 6' in length. Flip top units include adapters for most types of field supplied data jacks. Flip top units also include mounting clips and are standard in an anodized aluminum finish.

Modular Flip Top Unit Detail: Modular Flip Top Units in conjunction with C-Leg Training Tables conform to UL 962 and are certified to CSA C22.2 No. 68 by Intertek's ETL listing services. The Flip Top Units are available in single-sided configurations in data and electrical Port counts and sit flush with table top. A spring assist mechanism opens the top to provide access to electrical and data ports. Flip Top Units are fed with 60" (1524 mm) cord with modular connections. A Starter Box includes a 15 Amp circuit breaker, modular connection to adjacent Flip Top Unit, and 10' (3048 mm) cord with plug (NEMA 5-15P configuration) to the building. Flip Top Units include adapters for most types of field supplied data jacks. Flip Top Units also include mounting clips and are standard in an anodized aluminum finish.

Two-Circuit Modular System Detail: The two-circuit system in conjunction with C-Leg Training Tables and Y-Leg Collaborative Tables conform to UL 1286 and is certified to CSA C22.2 No. 203 by Intertek's ETL listing services. The two-circuit system is also listed to UL 183 by Underwriters Laboratories, Inc. (UL & ULC). The system contains duplex receptacles (NEMA 5-15R configuration) and pass-through connectors made of flexible metal conduit in lengths ranging from 12" – 96" (304 mm to 2438 mm). Three in-feed options are available including hardwire which consists of (4) 12 AWG wires, a modular wall feed, and a corded single circuit 60" (1524 mm) feed with NEMA 5-20P configured 20 Amp plug. The corded feed is for use with C-Leg Training tables only. All components with the exception of the corded feed are PVC free.

Technical Specifications – Planes Conference Tables

Modesty Panels

Training Table Modesty Panels: Modesty Panels are attached to the front edge of the training table with plastic brackets that secure to the surface into pre-drilled holes with include fasteners. Brackets pivot to allow screen to remain vertical when top is flipped. Brackets are of a two-piece design to allow for quick removal and reinstall of panel. Panels are available in the following materials:

- Fabric screens are made with 0.5" (12.7 mm) thick non-tackable wood composite core with fabric bonded to the faces and edges and the seams covered by a plastic spline that surrounds the edge perimeter.
- Laminate screens are made with 0.5" (12.7 mm) thick wood composite core with high pressure laminate bonded to the faces and the edges capped with a 0.039" (1 mm) ABS edge.
- Wood Veneer screens are made with 0.5" (12.7 mm) thick wood composite core with wood veneer bonded to the faces and edges.

Cart Construction

Cart Construction, General: Vertical and horizontal frame components are extruded aluminum. Most carts are available with either laminate or veneer surfaces except the Catering cart, which is laminate only. Core is constructed of particleboard, thicknesses are indicated below. Edges are 0.039" (1 mm) thick edgeband on laminate or 0.024" (.6 mm) thick wood edgeband with veneer surface. Each cart has the option of either glides or two locking and two non-locking casters. Casters and glides are 3.15" high (80 mm), with glides offering 0.5" height (12.7 mm) adjustment.

Small Media Carts: One internal shelf is included with routes on the underside to seat onto supporting pins. Shelf is height-adjustable in 1" (25.4 mm) increments. Carts has one door that utilizes a touch latch mechanism to hold door closed and a spring to push door open when disengaged. Top panel – 1.125" (28.6 mm) thick; side panel, back panel, bottom panel, shelves – 0.688" (17.5 mm) thick.

Medium Media Carts: Internal shelving included with routes on the underside to seat onto supporting pins. Shelf is height-adjustable in 1" (25.4 mm) increments. Two lower doors utilize a touch latch mechanism to hold doors closed and a spring to push door open when disengaged. Two upper (flap) doors are held closed with a magnetic push available in either black or chrome trim. Top panel, side panel, back panel, bottom panel, shelves – 0.688" (17 mm) thick. latch. Optional locks for doors are

Catering Carts: Include one center side access compartment with an adjustable shelf in 3.5" (89 mm) increments. Carts include two beverage compartments with retaining rails on either end. Top panel – 1.125" thick (28.6 mm); side panel, back panel, bottom panel, shelves – 0.688" (17.5 mm) thick.

Cart Podium: A 21" (533 mm) x 21" (533 mm) sloping top features an aluminum paper edge. The user side of the podium has an open shelf and lower storage with lockable touch latch door and one internal shelf with routes on the underside to seat onto supporting pins. The shelf is height-adjustable in 1" (25.4 mm) increments. The Podium back has a lockable full height door with full height enclosure for power and cable management.

Credenza Construction

Credenza Tops: Laminate top versions consist of a 1.125" (28.6 mm) thick engineered composite panel core with a 0.028" thick laminate face, 0.028" (.7 mm) thick backer and 0.039" (1 mm) thick edgeband. Veneer tops consist of a 1.125" (28.6 mm) thick engineered composite panel core with a 0.020" (.5 mm) thick veneer face, 0.020" (.5 mm) thick backer and 0.024" (.6 mm) thick edgeband

Credenza Bases: Credenza base configurations include: two doors - 36" (914 mm) width; three doors - 48" (1219 mm) and 54" (1372 mm) widths; 4 doors – 72" (1829 mm) width; 6 doors – 96" (2438 mm) and 108" (2743 mm) widths. Bases are 19.5" (495 mm) deep and available in 19" (483 mm) high with a single shelf or 29" (737 mm) high with two shelves. Shelves adjust in 1.25" (31.7 mm) increments. Credenza base legs are powder coat painted cast aluminum with a glide that provides 0.5" (12.7 mm) height adjustment. Credenzas are constructed with engineered composite panel core and are available with either laminate or veneer surface. Laminate versions are finished with a balanced 0.028" (.7 mm) thick laminate with 0.039" (1 mm) thick edgeband along exposed edges. Veneer credenza panels are finished with a balanced 0.020" (.5 mm) thick veneer with 0.024" (.6 mm) thick wood edgeband on exposed edges. A touch latch mechanism holds doors closed with a spring to push the door open when disengaged. The doors are available with a locking option.

Credenza Slider Units: 10" (254 mm) and 16" (406 mm) heights and 36" (914 mm) and 54" (1372 mm) widths are available. Core construction is an engineered composite panel core with either laminate or veneer on the case. All slider unit panel cores are 0.688" (17.5 mm) thick with balanced 0.028" (.7 mm) thick laminate or 0.020" (.5 mm) thick veneer on both sides. Slider doors are tempered glass or acrylic and are available with a lock option offered in either black or chrome. Door pulls are extruded aluminum and powder coat painted.

Specification Guide – PopUp Tables

Product Details Section

Product Details – PopUp Tables

Rectangle

18" Deep – PopUp Table

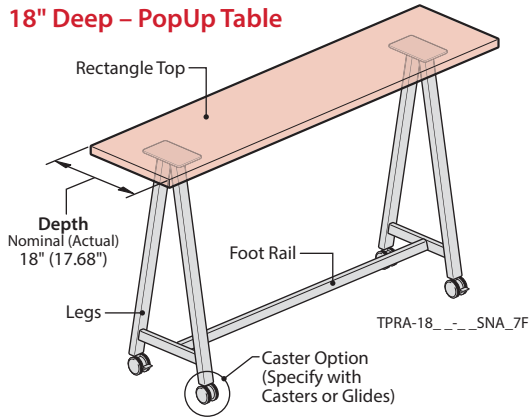

24" Deep – PopUp Table

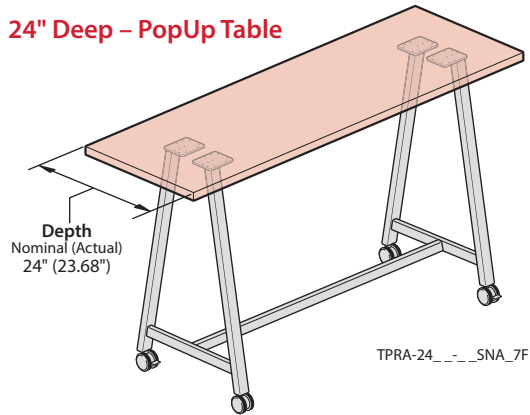

30" Deep – PopUp Table

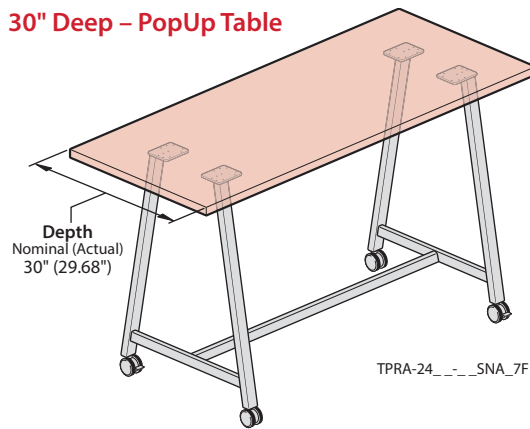

Base Foot Options:

- Foot options – (G) Glides or (C) Casters.
- Finished Table heights will be the same for Casters or Glides.
- Casters and Glides are not interchangeable.

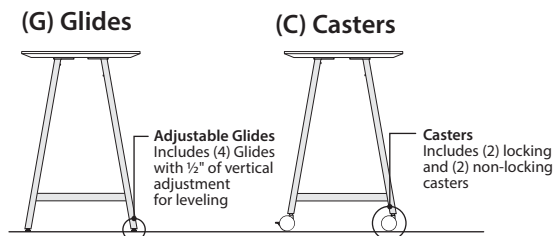

Component Materials and Finishes

COMPONENT NAME		MATERIALS/FINISHES
Rectangle Top	(L) Laminate	Specify surface color and separate edge finish color. Edge Options: (J) Edgeband or (F) Knife
	(W) Wood	Specify wood finish color for surface/edge. Edge Options: (K) Edgeband or (U) Knife
Legs	Painted Metal	Specified Leg trim color.
Foot Rail	Painted Metal	Specified Foot Rail trim color.
Foot Options	Glides (Option G)	Standard in Graphite
	Casters (Option C)	Light Platinum Hub with Graphite Tread
		Fog Hub with Graphite Tread
		Black Hub with Black Tread

Edge Options

- Specified edge option is applied on all edges of the top.
- Tops are standard 1 3/16" thick.

Edge Options for Laminate Worksurfaces

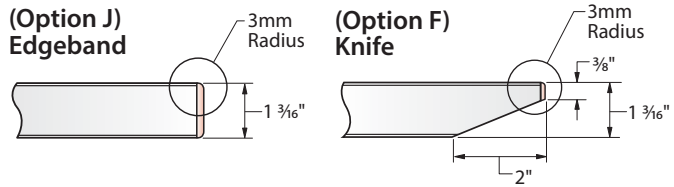

Edge Options for Wood Worksurfaces

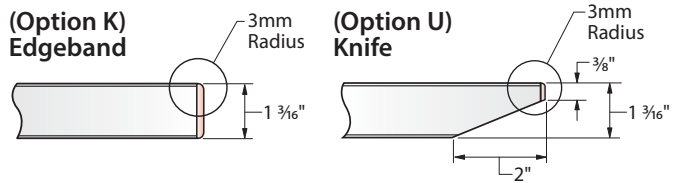
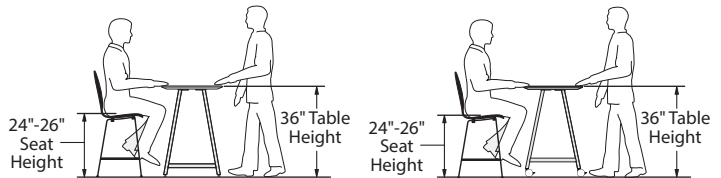

Table Heights

PopUp Tables are available with (2) heights (36" or 41" high), to accommodate a variety of sitting and standing work styles.

36" High Table

- Specify with counter height stools (24"-26" seat height).



41" High Table

- Specify with bar height stools (28"-30" seat height).

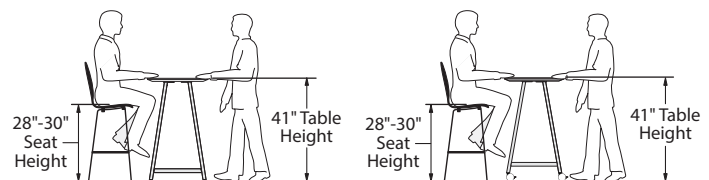

Note PopUp Tables are not for use with screens, modesty panels, AKPs, monitor arms or suspended pedestals.

Product Details – PopUp Tables

Rectangle – Dimensions

18" Deep Table

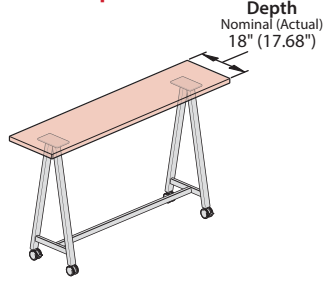

Depth Nominal (Actual)	Widths Nominal (Actual)
18" (17.68")	48" (47.68")
	54" (53.68")
	60" (59.68")
	66" (65.68")
	72" (71.68")

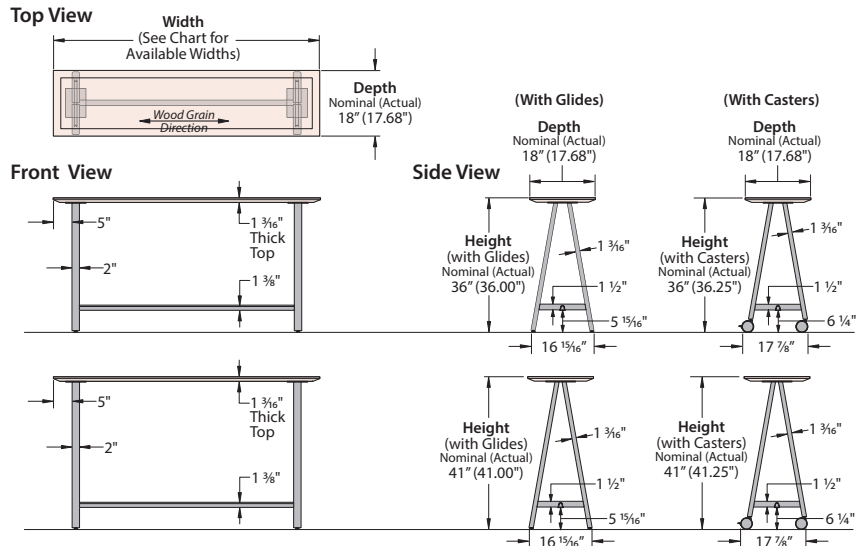

24" Deep Table

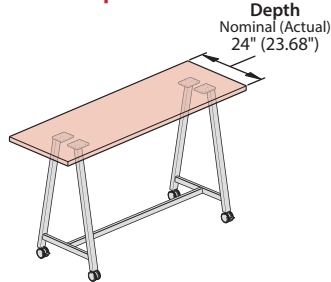

Depth Nominal (Actual)	Widths Nominal (Actual)
24" (23.68")	48" (47.68")
	54" (53.68")
	60" (59.68")
	66" (65.68")
	72" (71.68")

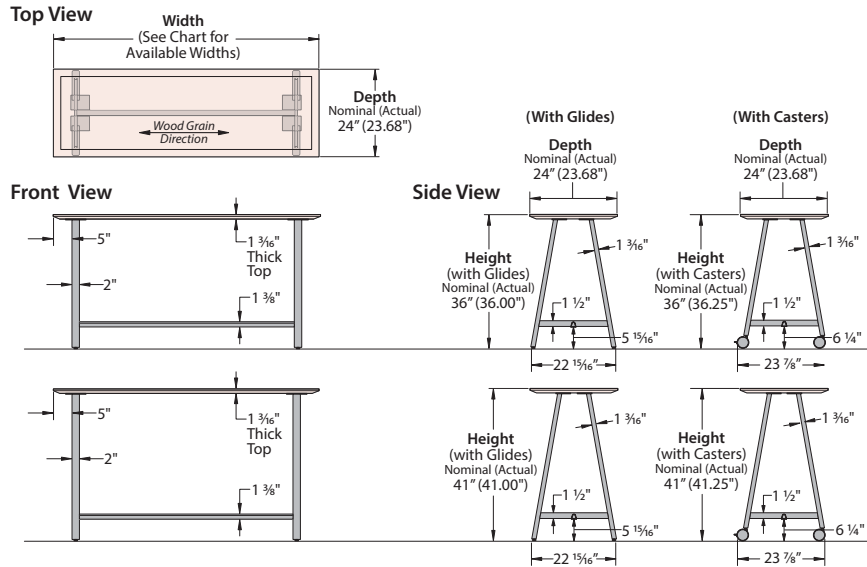

30" Deep Table

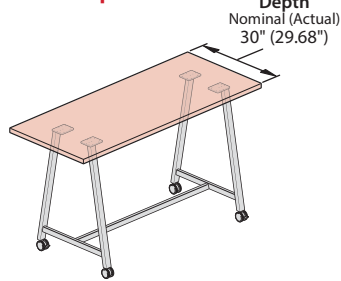

Depth Nominal (Actual)	Widths Nominal (Actual)
30" (29.68")	48" (47.68")
	54" (53.68")
	60" (59.68")
	66" (65.68")
	72" (71.68")

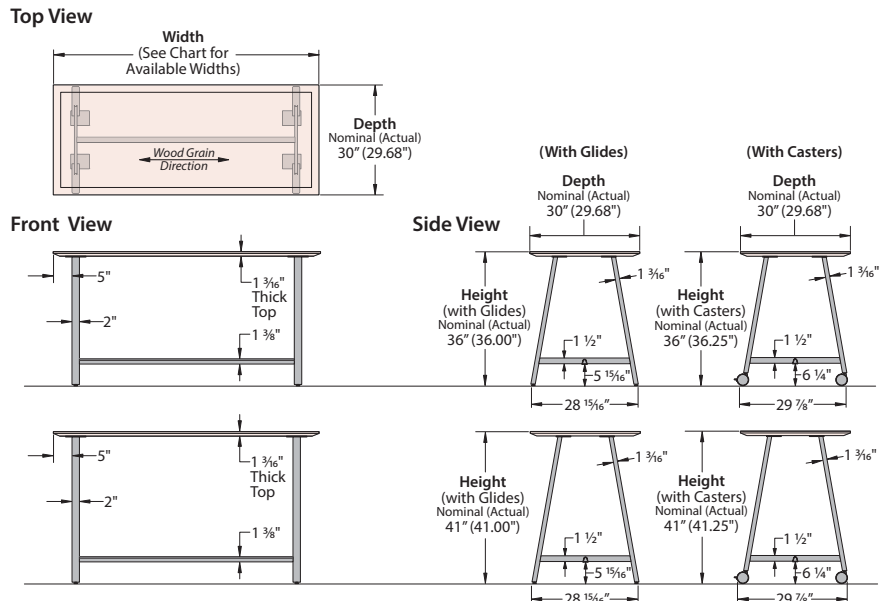

Product Details – PopUp Tables

Oval (Rectangle Radius Corner)

18" Deep – PopUp Table

(41" high with casters shown)

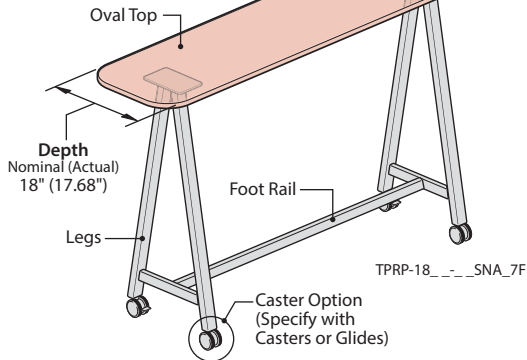

24" Deep – PopUp Table

(41" high with casters shown)

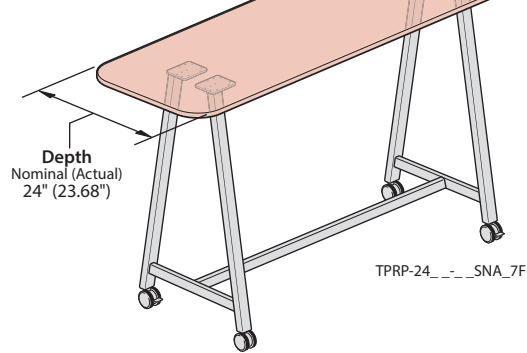

30" Deep – PopUp Table

(41" high with casters shown)

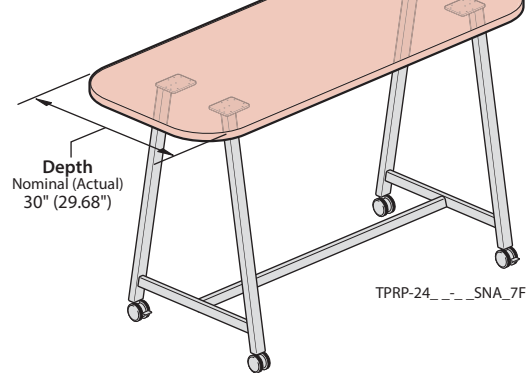

Base Foot Options:

- Foot options – (G) Glides or (C) Casters.
- Finished Table heights will be the same for Casters or Glides.
- Casters and Glides are not interchangeable.

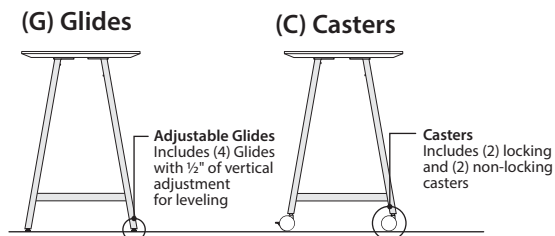

Component Materials and Finishes

COMPONENT NAME		MATERIALS/FINISHES
Oval Top	(L) Laminate	Specify surface color and separate edge finish color. Edge Options: (J) Edgeband or (F) Knife
	(W) Wood	Specify wood finish color for surface/edge. Edge Options: (K) Edgeband or (U) Knife
Legs	Painted Metal	Specified Leg trim color.
Foot Rail	Painted Metal	Specified Foot Rail trim color.
Foot Option	Glides (Option G)	Standard in Graphite
	Casters (Option C)	Light Platinum Hub with Graphite Tread
		Fog Hub with Graphite Tread
		Black Hub with Black Tread

Edge Options

- Specified edge option is applied on all edges of the top.
- Tops are standard 1 3/16" thick.

Edge Options for Laminate Worksurfaces

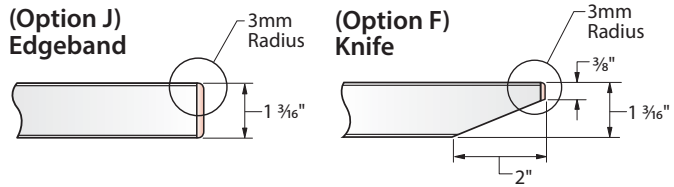

Edge Options for Wood Worksurfaces

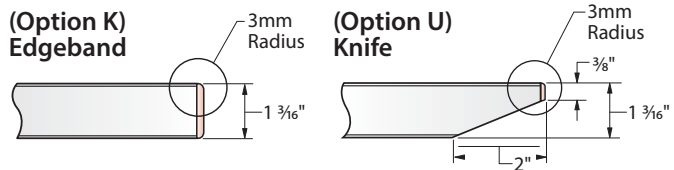
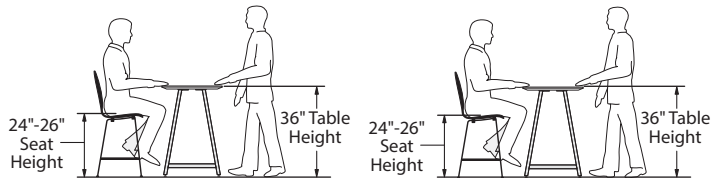

Table Heights

PopUp Tables are available with (2) heights (36" or 41" high), to accommodate a variety of sitting and standing work styles.

36" High Table

- Specify with counter height stools (24"-26" seat height).



41" High Table

- Specify with bar height stools (28"-30" seat height).

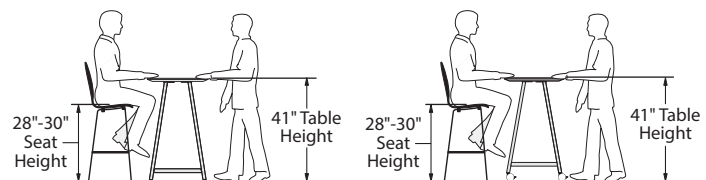

Note PopUp Tables are not for use with screens, modesty panels, AKPs, monitor arms or suspended pedestals.

Product Details – PopUp Tables

Oval (Rectangle Radius Corner) – Dimensions

18" Deep Table

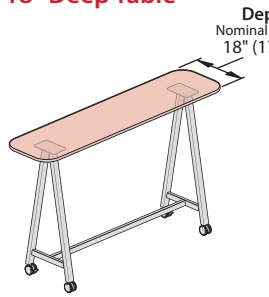

Depth Nominal (Actual)	Widths Nominal (Actual)
18" (17.68")	48" (47.68")
	54" (53.68")
	60" (59.68")
	66" (65.68")
	72" (71.68")

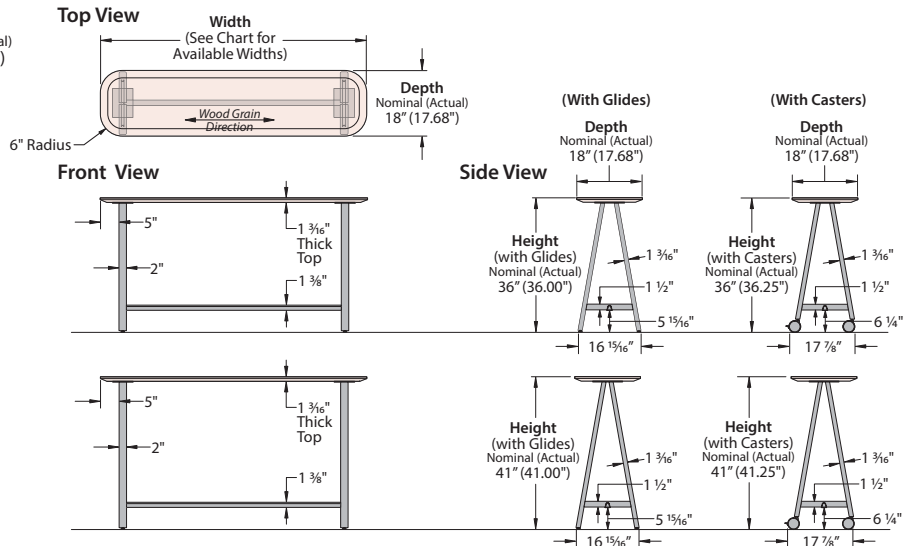

24" Deep Table

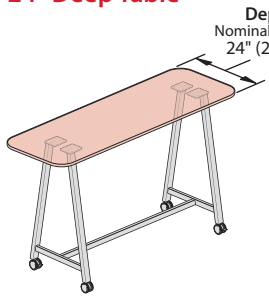

Depth Nominal (Actual)	Widths Nominal (Actual)
24" (23.68")	48" (47.68")
	54" (53.68")
	60" (59.68")
	66" (65.68")
	72" (71.68")

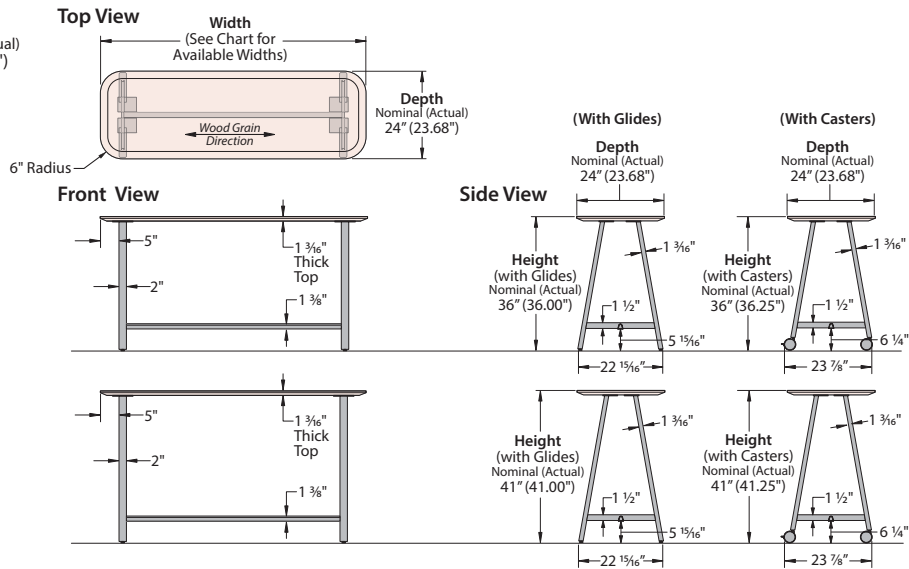

30" Deep Table

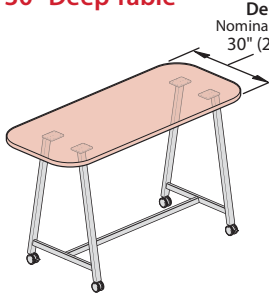

Depth Nominal (Actual)	Widths Nominal (Actual)
30" (29.68")	48" (47.68")
	54" (53.68")
	60" (59.68")
	66" (65.68")
	72" (71.68")

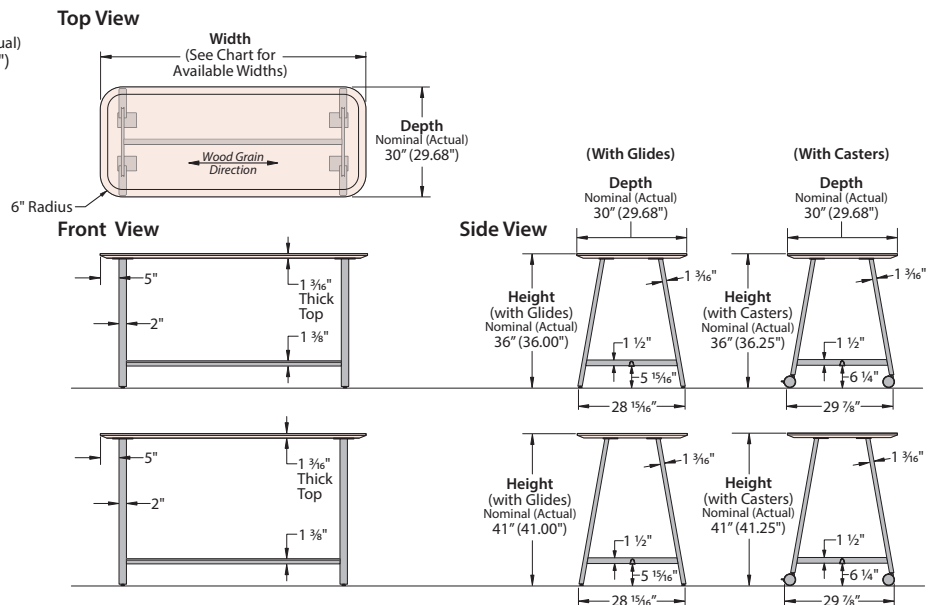

Product Details – PopUp Tables

Racetrack

18" Deep – PopUp Table

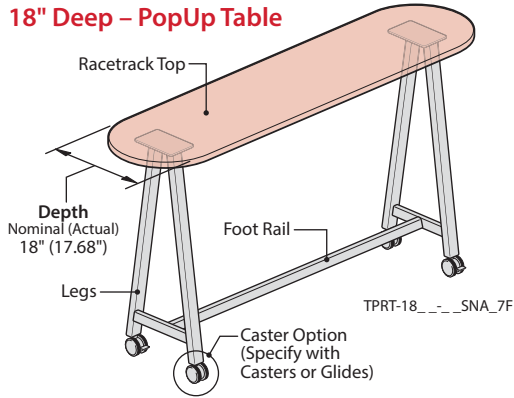

24" Deep – PopUp Table

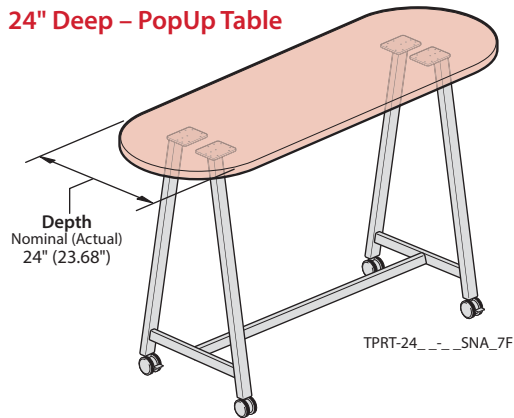

30" Deep – PopUp Table

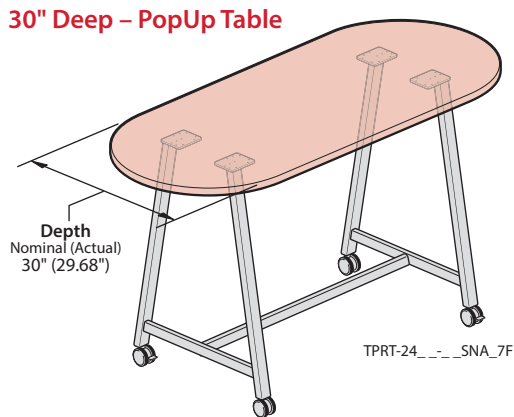

Base Foot Options:

- Foot options – (G) Glides or (C) Casters.
- Finished Table heights will be the same for Casters or Glides.
- Casters and Glides are not interchangeable.

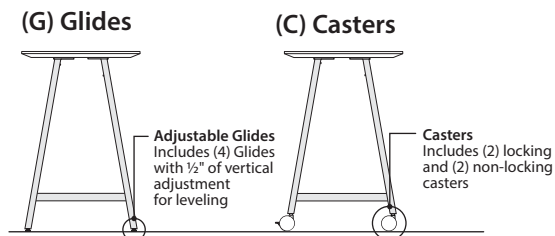

Component Materials and Finishes

COMPONENT NAME		MATERIALS/FINISHES
Racetrack Top	(L) Laminate	Specify surface color and separate edge finish color. Edge Options: (J) Edgeband or (F) Knife
	(W) Wood	Specify wood finish color for surface/edge. Edge Options: (K) Edgeband or (U) Knife
Legs	Painted Metal	Specified Leg trim color.
Foot Rail	Painted Metal	Specified Foot Rail trim color.
Foot Option	Glides (Option G)	Standard in Graphite
	Casters (Option C)	Light Platinum Hub with Graphite Tread
		Fog Hub with Graphite Tread
		Black Hub with Black Tread

Edge Options

- Specified edge option is applied on all edges of the top.
- Tops are standard 1 3/16" thick.

Edge Options for Laminate Worksurfaces

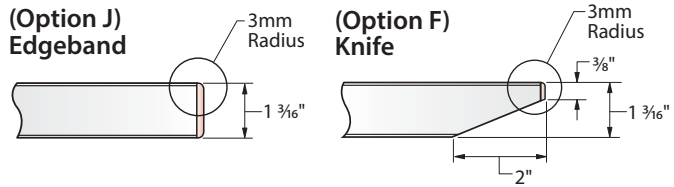

Edge Options for Wood Worksurfaces

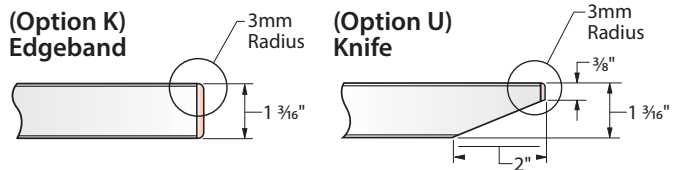
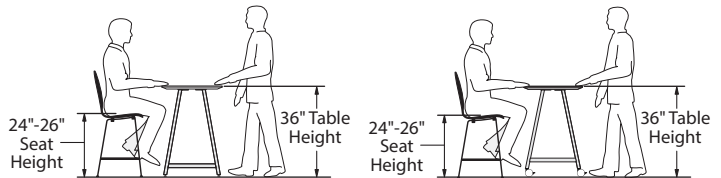

Table Heights

PopUp Tables are available with (2) heights (36" or 41" high), to accommodate a variety of sitting and standing work styles.

36" High Table

- Specify with counter height stools (24"-26" seat height).



41" High Table

- Specify with bar height stools (28"-30" seat height).

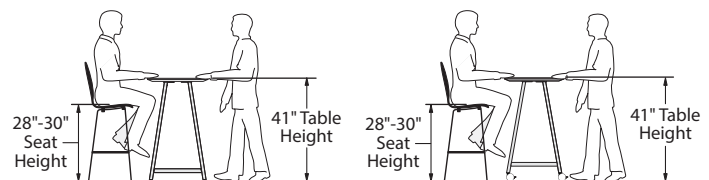

Note PopUp Tables are not for use with screens, modesty panels, AKPs, monitor arms or suspended pedestals.

Product Details – PopUp Tables

Racetrack – Dimensions

18" Deep Table

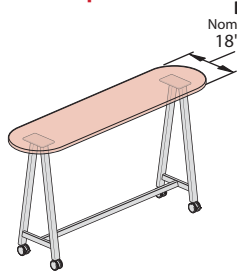

Depth
Nominal (Actual)
18" (17.68")

Depth Nominal (Actual)	Widths Nominal (Actual)
18" (17.68")	48" (47.68")
	54" (53.68")
	60" (59.68")
	72" (71.68")

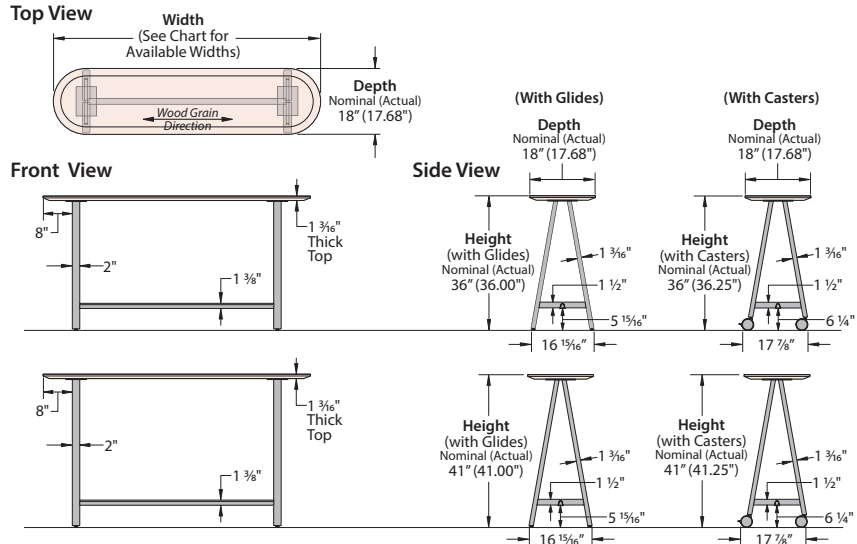

24" Deep Table

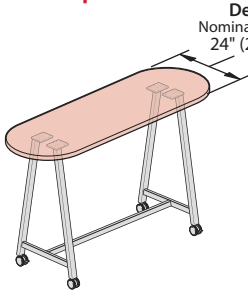

Depth
Nominal (Actual)
24" (23.68")

Depth Nominal (Actual)	Widths Nominal (Actual)
24" (23.68")	60" (59.68")
	66" (65.68")
	72" (71.68")

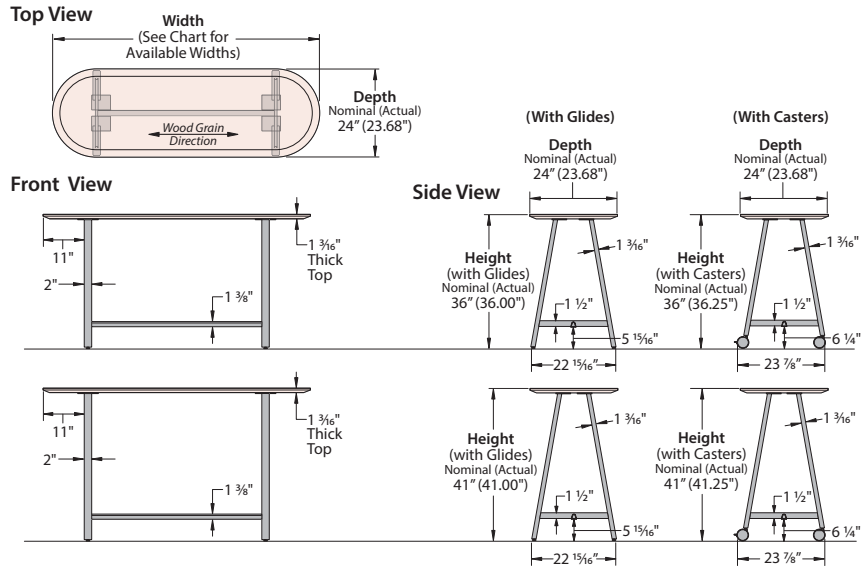

30" Deep Table

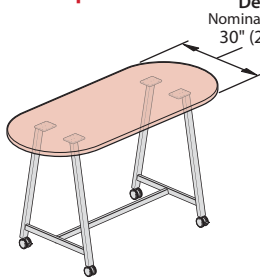

Depth
Nominal (Actual)
30" (29.68")

Depth Nominal (Actual)	Widths Nominal (Actual)
30" (29.68")	72" (71.68")

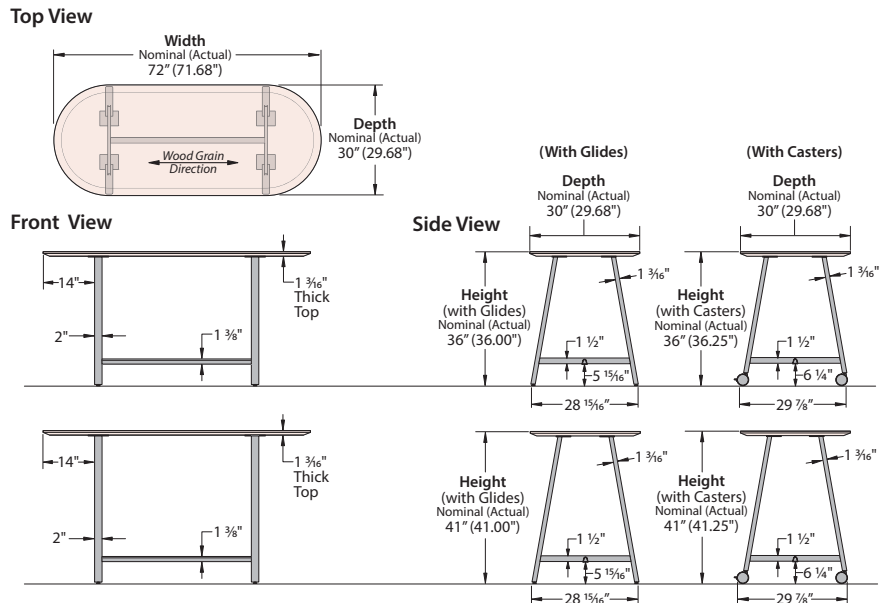

Product Details – PopUp Tables

Accent Plates

- Includes (2) Plates and attachment hardware. Designed to be installed in the top center section of each leg assembly, the specifiable finish provides an aesthetic accent option for the table.
- Each plate is specifically designed for installation in a specific table size. Ensure each plate is specified to match corresponding table depth and height.

Component Materials and Finishes

COMPONENT NAME	MATERIALS/FINISHES	
Accent Plates	(P) Painted Metal	Specify trim color.
	(W) Wood	Specify wood color.

For use with 24" Depth/36" High Tables

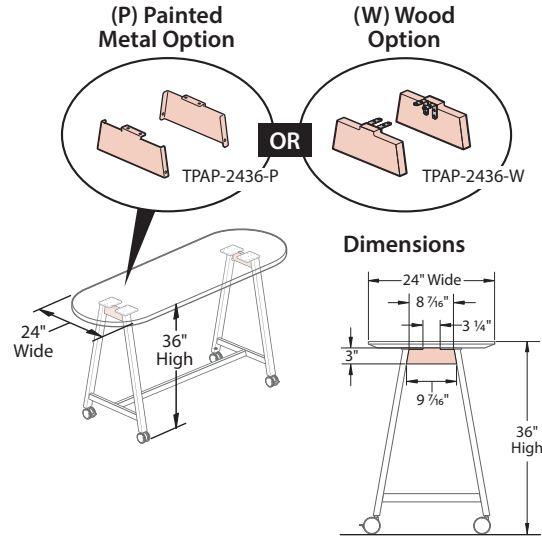

For use with 30" Depth/36" High Tables

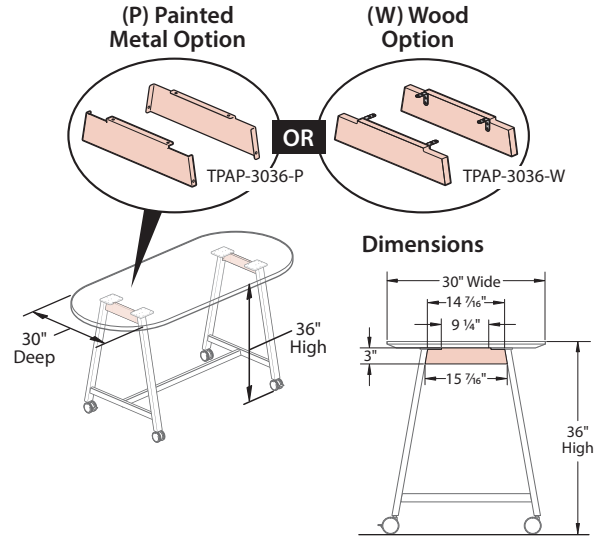

For use with 24" Depth/41" High Tables

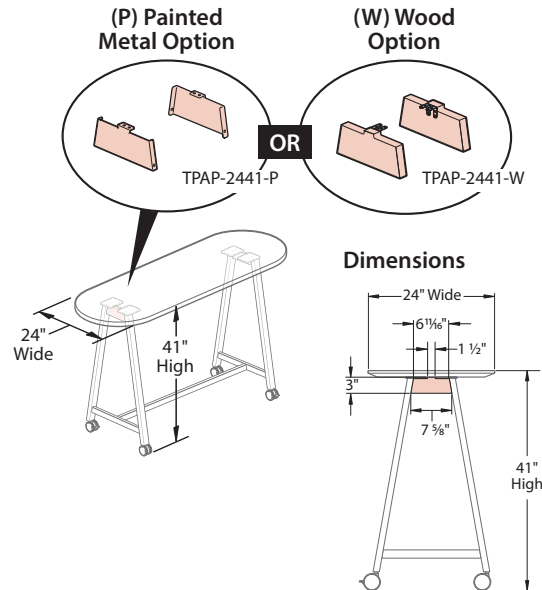

For use with 30" Depth/41" High Tables

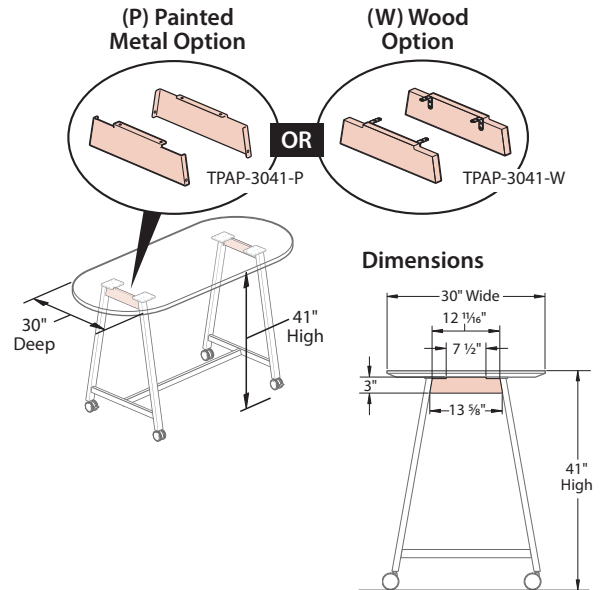

Note • Accent Plate is NOT for use on 18" deep PopUp tables.

Product Details – PopUp Tables

Vertical Wire Channel

- Provides vertical cable management from the underside of the worksurface to the floor.
- Attaches to the inside of the angled leg.
- Specify to accommodate table height and Accent Plate use (table depth does not impact specification).

Component Materials and Finishes

COMPONENT NAME	MATERIALS/FINISHES	
Vertical Wire Channel	(P) Painted Metal	Specify trim color.

For use with No Accent Plate / 36" High Tables

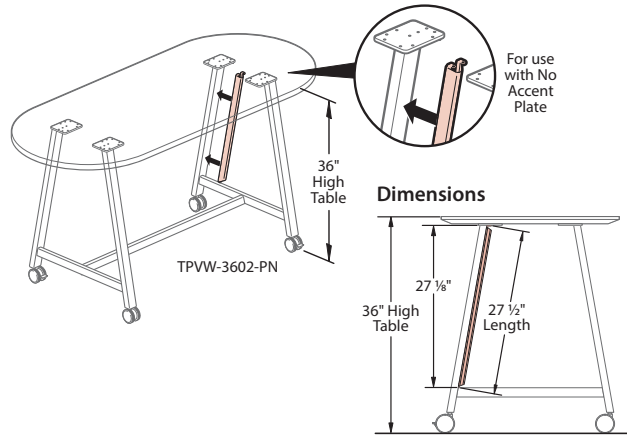

For use with No Accent Plate / 41" High Tables

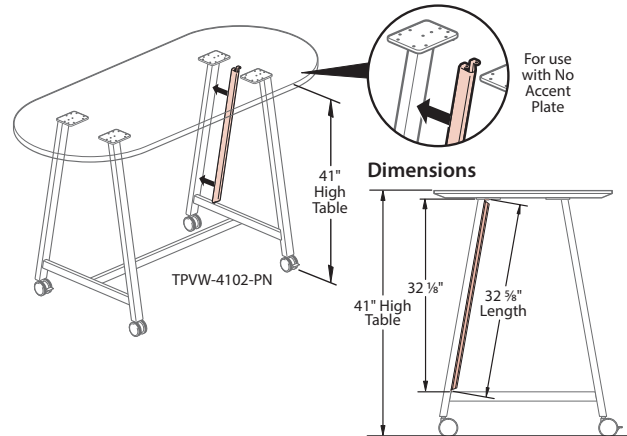

For use with With Accent Plate / 36" High Tables

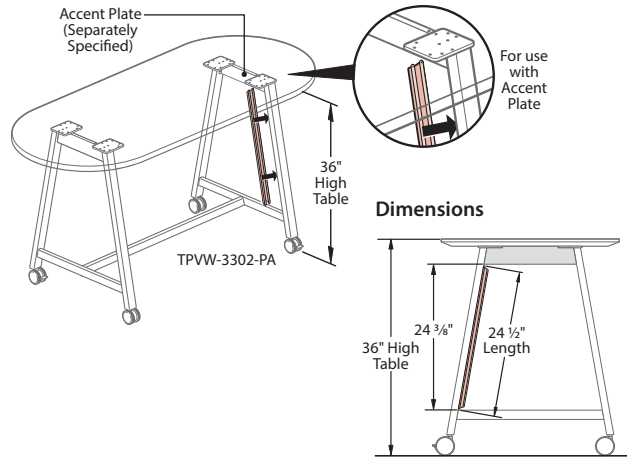

For use with With Accent Plate / 41" High Tables

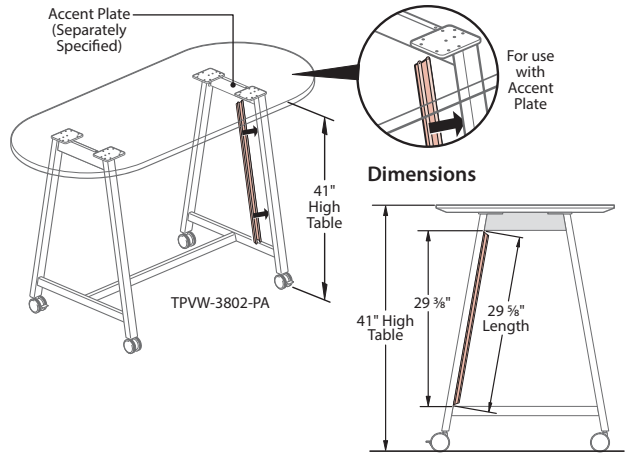

Dimensions

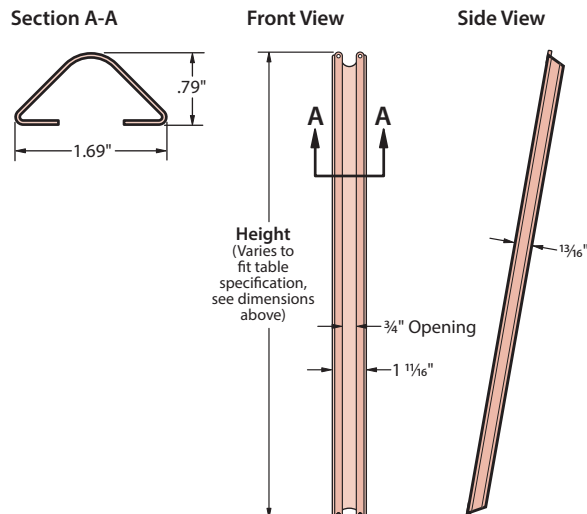

Cable Capacities

This chart shows the number of communication cables that can be routed through specific pathways. Cable capacities are based on 0.20" (5mm), 0.25" (6mm), and 0.30" (8mm) diameter cables at 60% and 40% fill capacity. TIA/EIA 569 suggests a cable fill of 40% for planning and up to 60% for unplanned or future additions. The TIA category designations for cable are not size specific but typically the higher the category number the larger the diameter the cable is. As a general rule a Category 5e (Enhanced) cable is approximately 0.20" in diameter, the Category 6 0.25", and a Category 6A (Augmented) 0.30". The actual diameter will vary depending on manufacturer and whether it is a plenum rated cable or riser (PVC) cable.

Example	AREA Sq In	AREA Sq mm	60% Fill			40% FILL		
			0.20"	0.25"	0.30"	0.20"	0.25"	0.30"
One Square Inch Cable Capacity	1.0	645	19	12	8	13	8	6
Vertical Pathway								
Vertical Wire Channel	.704	454	13	9	6	9	6	4

Product Details – PopUp Tables

Electrical Components – Above Worksurface – Flush Mounted Power and Data

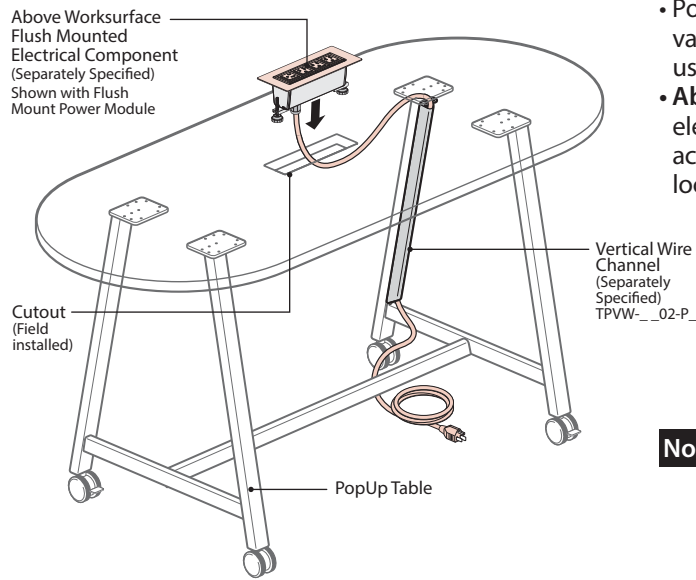

- PopUp Tables are designed to accommodate a wide variety of Haworth Electrical Components to provide users access to power, charging and data.
- **Above Worksurface – Flush Mounted Power** places electrical components flush to the top for user access, requires field installed cutouts (ensure cutout locations do not interfere with the legs).

Note • Application may require approval of local authority having jurisdiction (AHJ); ensure compliance before placing orders and installing.

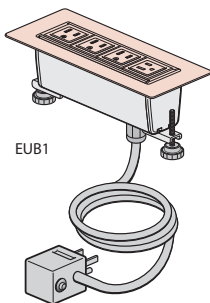

Flush Mount Power Module

- May be specified to provide power, USB charging, data and cable access.
- Available with 3, 4 or 6 port configurations.
- Mounts flush to horizontal surfaces, requires field installed cutouts.
- Available corded or hardwired (6' or 12' long), corded units with 4 or more power receptacles includes a circuit breaker plug.
- Power Modules specified with a data port includes a variety of data port adapters and blank covers, which can accommodate most varieties of field supplied data/AV Jacks.

Note • For additional information and details see the Cultivate Tables Price Book or the Accessories Price Book.

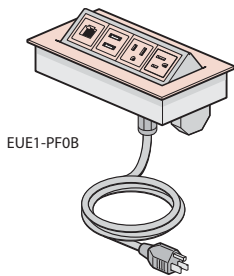

Flip Top Unit

- Provides power, USB charging, data and cable access.
- Single sided modules are available with 2, 4 or 6 ports, double sided modules are available 4, 8 or 12 ports.
- Available corded or hardwired (6' or 12' long), corded units with 4 or more power receptacles includes a circuit breaker plug.
- Units specified with a data port includes a variety of data port adapters and blank covers, which can accommodate most varieties of field supplied data/AV Jacks.

Note • For additional information and details see the Accessories Price Book.

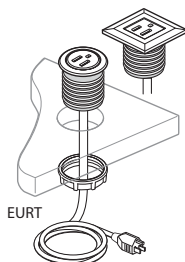

Bezel Utility Module

- May be specified (1) power receptacle or (1) 2-port USB charger.
- Available with a round or square bezel.
- Mounts flush to horizontal surfaces, requires field installed cutouts.
- Available corded (6' or 12' long).

Note • For additional information and details see the Accessories Price Book.

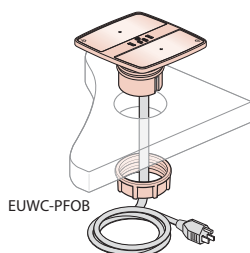

Wireless Charging Module

- Available with a Single Wireless Charging Pad, or Dual Wireless Charging Pads - compatible with all Qi-enabled smartphones and devices.
- Includes (1) power module, (1) or (2) USB charging ports, and (1) or (2) Qi charging pads.
- Available with cords (6' or 12' long) or with flexible metal conduit (12' long).

Note • For additional information and details see the Cultivate Price Book.

Product Details – PopUp Tables

Electrical Components – Above Worksurface – Edge Mounted Power and Data

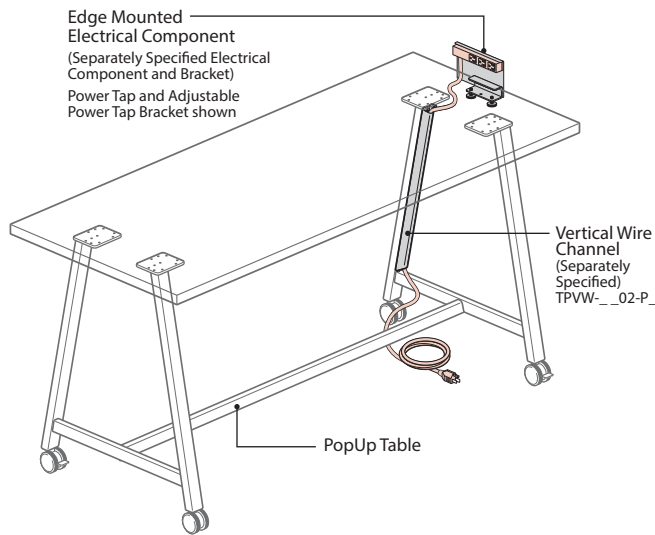

- PopUp Tables are designed to accommodate a wide variety of Haworth Electrical Components to provide users access to power, charging and data.
- **Above Worksurface – Edge Mounted Power** uses brackets to place the electrical components on the edge of the top for above the worksurface access.

Note • Application may require approval of local authority having jurisdiction (AHJ); ensure compliance before placing orders and installing.

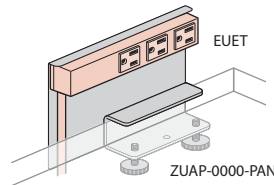

Power Tap and Adjustable Bracket

- Available corded or hardwired (6', 9', 15' or 25' long) with (3) 15 Amp receptacles.
- Requires a separately specified fixed or adjustable Power Tap Bracket for mounting.

Note • For additional information and details see the Accessories Price Book.

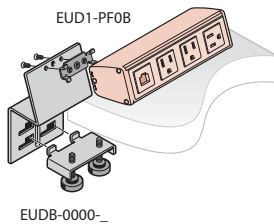

Enhanced Power Module and Above Worksurface – Adjustable Bracket

- May be specified to provide a combination of power, USB charging, and data/AV ports.
- Available corded or hardwired (6' or 12' long), corded units with 4 or more power receptacles includes a circuit breaker plug.
- Units specified with a data port includes a variety of data port adapters and blank covers, which can accommodate most varieties of field supplied data/AV Jacks.
- Requires a separately specified Adjustable or Fixed Enhanced Power Module Bracket for mounting to the edge of the top (see the Accessories Price List for details).

Note • For additional information and details see the Accessories Price Book.

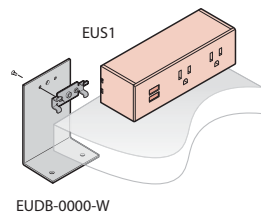

Seamless Enhanced Power Module and Above Worksurface – Fixed Bracket

- May be specified to provide a combination of power, USB charging, and data/AV ports.
- Available corded (6' or 12' long) or hardwired (12'), corded units with 4 or more power receptacles includes a circuit breaker plug.
- Units specified with a data port includes a variety of data port adapters and blank covers, which can accommodate most varieties of field supplied data/AV Jacks.
- Requires a separately specified Adjustable or Fixed Enhanced Power Module Bracket for mounting to the edge of the top (see the Accessories Price List for details).

Note • For additional information and details see the Accessories Price Book.

Product Details – PopUp Tables

Electrical Components – Below Worksurface – Power and Data

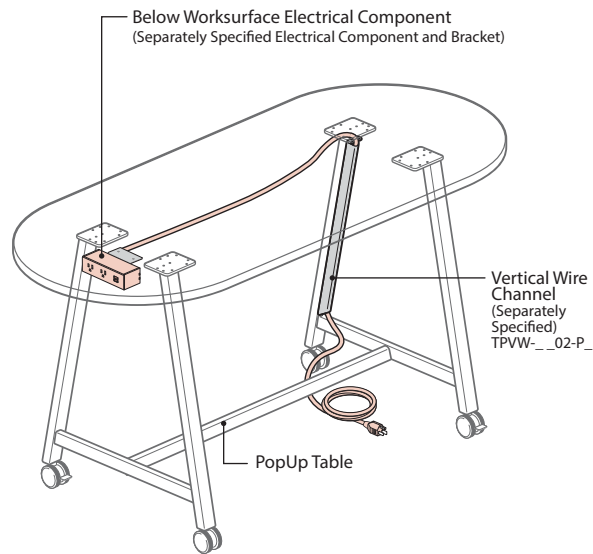

- PopUp Tables are designed to accommodate a wide variety of Haworth Electrical Components to provide users access to power, charging and data.
- **Below Worksurface Power** uses brackets to place the electrical components below the worksurface. Ensure mounting locations do not interfere with table legs, accent plates or user kneespace.

Note • Application may require approval of local authority having jurisdiction (AHJ); ensure compliance before placing orders and installing.

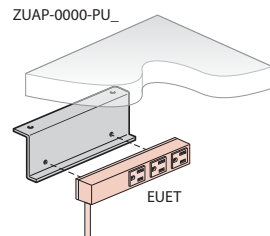

Power Tap and Under Surface Bracket

- Available corded or hardwired (6', 9', 15' or 25' long) with (3) 15 Amp receptacles.
- Requires a separately Under Surface Power Tap Bracket for mounting.

Note • For additional information and details see the Accessories Price Book.

Product Details – PopUp Tables

Bag Hook

- Attaches to underside of 1 3/16" thick tops for hanging bags or other small items (50 lb. limit).
- Includes attachment hardware, the hook will swivel with installation of plastic washers (ensure clearance).

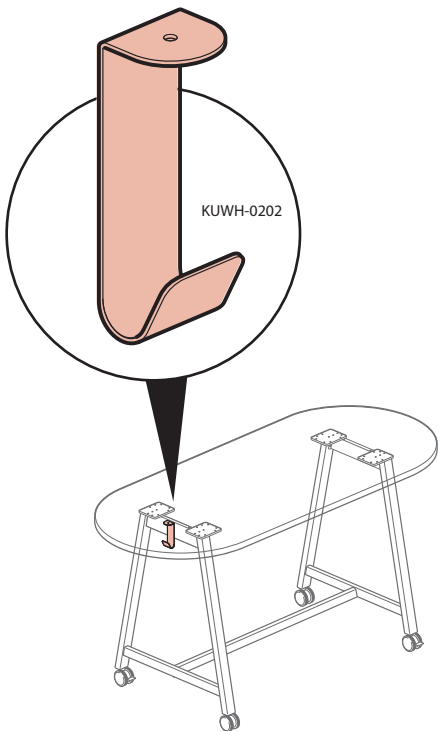

Component Materials/Finishes

COMPONENT NAME	MATERIALS/ FINISHES
Bag Hook	Painted Metal – Specified trim color.

Dimensions

Top View

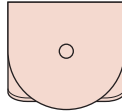

Front View

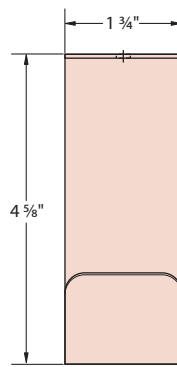

Side View

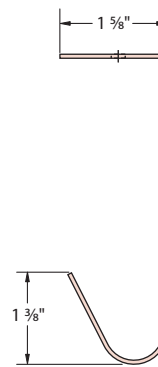

Note

See the Cultivate Tables Price Book for pricing and details.

Kneespace Clearance

- Mounting between Legs is not recommended due to issues with kneespace clearance, always ensure mounting location provides adequate clearance for users.

This page intentionally left blank.

Specification Guide – PopUp Tables

Technical Specifications Section

Technical Specifications – PopUp Tables

Tops

Tops are 1.18" (30.2mm) thick made with a solid engineered composite wood. The composite wood is made with 100% recycled and/or recovered wood fiber bonded with resin. These materials are 3rd party certified compliant with CARB Phase 2 and EPA TSCA Title VI requirements for formaldehyde emissions. FSC™ Certification for composite wood materials are available.

Top are 3rd party certified compliant by Greenguard, SCS Indoor Advantage, or Intertek Clean Air to ANSI/BIFMA X-7.1 Standard for Formaldehyde and TVOC Emissions of Low-Emitting Office Furniture and Seating.

Laminate worksurfaces are a balanced construction with high-pressure laminate on the top, a backer on the bottom and are available with the following plastic edges:

- 0.125" (3mm) radius edge band on perimeter of top.
- 0.125" (3mm) radius edgeband with a 2" deep reverse chamfer. The exposed wood composite material on the bottom of the surface is sealed with a black or clear finish.

Wood veneer worksurfaces are balanced construction with wood veneer on the top, a balancing backer on the bottom and are available with the following wood edges:

- 0.125" (3mm) radius edge band on perimeter of top.
- 0.125" (3mm) radius edgeband with a 2" deep reverse chamfer. The exposed wood composite material is sealed with a black or clear finish.

Table Frame

Frames in heights of 36" (914mm) and 41" (1041mm) consist of the following components that are assembled in the field with threaded fasteners:

- Vertical angled tube legs are made with .080" (2mm) thick "D" shaped steel tube and are powdercoat painted. Legs can be specified with either glides that offer .50" (13mm) adjustment or casters, two locking and two non-locking. Glides and Casters are not interchangeable.
- Mounting plates are .250" (6.3mm) thick steel with a single mounting plate welded to a set of legs on 18" tables or individual mounting plates welded on each leg of 24" and 30" deep tops.
- Horizontal rails are made with 12-gauge, 1.5" (38.1mm) high "U" shaped steel rail and are powdercoat painted.
- Foot rails are made with 13-gauge, 1.3" (33mm) high "U" shaped steel rail and are powdercoat painted.
- Accent plate is made with 22-gauge steel and mounts at the apex of angled legs on 24" and 30" deep tops. It is attached to the legs and top with fasteners.
- Optional vertical wire manager is made of 18-gauge steel and attaches to inside of angled legs with threaded fasteners

Compose Finish/Color Legend

Wood Finishes

Grade A

Double Cut

2P-RL	Applegate
WL-RL	Beachwood
2R-RL	Butternut
WE-RD	Dune
WJ-RE	Ebony
2N-RL	Echo
W3-HR	Harbor
LQ-RH	Hazel Walnut
WE-RT	Melba
W4-PB	Pebble
WC-RW	Wenge

Grade B

Anegre Quarter Cut

NP-W15	Espresso
NP-W08	Golden
NP-W07	Light

Cherry

VC-CA1	Amber
VC-W23	American
VC-W33	Caramel
VC-W30	Heritage
VC-W32	Pacific

Cherry Quarter Cut

NX-U	Medium
------	--------

Maple

VP-LM	Light
VP-N	Natural
VP-AD	Sand

Maple Quarter Cut

NM-N	Natural
------	---------

Oak

VJ-W42	Brindle
VJ-W05	Natural

Rift Cut White Oak

NR-W15	Espresso
NR-W37	Fawn
NR-W40	Mocha
NR-W38	Tuxedo

Walnut

VR-W15	Espresso
VR-W21	Mahogany Satin
VR-W31	Retro

Walnut Quarter Cut

NW-W35	Clear
NW-W15	Espresso
NW-W31	Retro
NW-W41	Verdant

Laminate

Grade A

Solid Color

H-34	Beige
H-AK	Chalk
H-8J	Charcoal
H-3J	Graphite
H-62	Gray Tone
H-WL	Linen
H-3P	Platinum
H-AA	Putty
H-3E	Smoke

Patterned

H-P1	Linen Casual
H-P2	Linen Classic
H-P3	Linen Crisp
H-P4	Linen Flax

Wood

H-AM	Amber Cherry
H-AE	Maple
H-AD	Medium Cherry

Grade B

Premium Wood Grain

H-KA	Brazilwood
H-KG	Columbian Walnut
H-KP	Field Elm
H-KN	Grey Elm
H-KM	Landmark Wood
H-KL	Neo Walnut
H-KC	New Age Oak
H-KR	Phantom Ecru
H-KS	Phantom Pearl
H-KD	River Cherry
H-KE	Sanara
H-KF	Williamsburg Cherry

Grade E

Premium

H-C1	Hay
H-C2	Drift
H-C3	Pecan
H-C4	Molasses
H-C5	Mineral
H-C6	Hatch
H-C7	Tanned

Edgeband

Solid Color

HP-34	Beige
HP-AK	Chalk
HP-8J	Charcoal
HP-3J	Graphite
HP-62	Gray Tone
HP-WL	Linen
HP-3P	Platinum
HP-AA	Putty
HP-3E	Smoke

Patterned Edgeband

HP-P1	Linen Casual
HP-P2	Linen Classic
HP-P3	Linen Crisp
HP-P4	Linen Flax

Wood Grain

HP-KA	Brazilwood
HP-AM	Cherry
HP-KG	Columbian Walnut
HP-KP	Field Elm
HP-KN	Grey Elm
HP-KM	Landmark Wood
HP-AE	Maple
HP-AD	Medium Cherry
HP-KL	Neo Walnut
HP-KC	New Age Oak
HP-KR	Phantom Ecru
HP-KS	Phantom Pearl
HP-KD	River Cherry
HP-KE	Sanara
HP-KF	Williamsburg Cherry

Ply-Edge

HP-PW	Ply-Edge
-------	----------

Premium

HP-C1	Hay
HP-C2	Drift
HP-C3	Pecan
HP-C4	Molasses
HP-C5	Mineral
HP-C6	Hatch
HP-C7	Tanned

Trim

Grade A

Smooth

TR-R	Beige
TR-AK	Chalk
TR-K	Charcoal
TR-C1	Cocoa
TR-J	Graphite
TR-G	Gray Tone
TR-AA	Putty
TR-E	Smoke
TR-PLS	Smooth Plaster
TR-FM	Snow

Textured

TR-TY	Cement
TR-TG	Grout
TR-TF	Pitch
TR-TW	Plaster

Grade B

Smooth

TR-1C	Accent Blue
TR-1D	Accent Green
TR-1E	Accent Orange
TR-1F	Accent Red
TR-1G	Blue Jay
TR-1L	Brindle
TR-1R	Brownstone
TR-CTS	Chartreuse
TR-1N	Night
TR-1Q	Park
TR-RR	Rusty Red
TR-1M	Sable
TR-1P	Seville
TR-1J	Sky Blue
TR-1H	Terra
TR-1K	Wren

Smooth Metallic

TR-DM	Dark Bronze Metallic
TR-MC	Metallic Champagne
TR-LE	Metallic Silver

Textured Metallic

TR-AL	Alloy
TR-AR	Argent
TR-HE	Hellenic

ALERT: These materials are current, however they are being considered for future obsolescence due to low volume.

Wood:

VR-W12	Naturally
WF-RC	Sorrel Double Cut

Laminate:

H-EK	Owl Nest
H-EC	Quail Nest
H-EA	Robin Nest
H-DE	Wheat Grain

Forest Stewardship Council (FSC) Statement:

In our continuing support of sustainable forestry and responsible purchasing, Haworth North America is offering FSC certified wood products at no up-charge. By providing FSC certified material, Haworth is supporting our client's green building goals and demonstrating our collective commitment to source materials more sustainably.

Haworth will provide to you the necessary FSC-certified paperwork with your shipment. For more information, FAQs, and a complete FSC product list (including product exceptions), go to the Library and search FSC.

Cultivate Finish/Color Legend

Wood Finishes

Grade A

Double Cut

2P-RL	Applegate
WL-RL	Beachwood
2R-RL	Butternut
WE-RD	Dune
WJ-RE	Ebony
2N-RL	Echo
LQ-RH	Hazel Walnut
WE-RT	Melba
WC-RW	Wenge

Grade B

Anegre Quarter Cut

NP-W15	Espresso
NP-W08	Golden
NP-W07	Light

Cherry

VC-CA1	Amber
VC-W23	American
VC-W33	Caramel
VC-W30	Heritage
VC-W32	Pacific

Cherry Quarter Cut

NX-U	Medium
------	--------

Maple

VP-LM	Light
VP-N	Natural
VP-AD	Sand

Maple Quarter Cut

NM-N	Natural
------	---------

Oak

VJ-W42	Brindle
VJ-W05	Natural

Rift Cut White Oak

NR-W35	Clear
NR-W15	Espresso
NR-W37	Fawn
NR-W40	Mocha
NR-W38	Tuxedo

Walnut

VR-W15	Espresso
VR-W21	Mahogany Satin
VR-W31	Retro

Walnut Quarter Cut

NW-W35	Clear
NW-W15	Espresso
NW-W31	Retro
NW-W41	Verdant

Laminate Finishes

Grade A

Solid Color

H-34	Beige
H-AK	Chalk
H-8J	Charcoal
H-3J	Graphite
H-62	Gray Tone
H-WL	Linen
H-3P	Platinum
H-AA	Putty
H-3E	Smoke

Grade A

Patterned

H-P1	Linen Casual
H-P2	Linen Classic
H-P3	Linen Crisp
H-P4	Linen Flax

Wood

H-AM	Amber Cherry
H-AE	Maple
H-AD	Medium Cherry

Grade B

Premium Wood Grain

H-KA	Brazilwood
H-KG	Columbian Walnut
H-KP	Field Elm
H-KN	Grey Elm
H-KM	Landmark Wood
H-KL	Neo Walnut
H-KC	New Age Oak
H-KR	Phantom Ecru
H-KS	Phantom Pearl
H-KD	River Cherry
H-KE	Sanara
H-KF	Williamsburg Cherry

Edgeband

Solid Color

HP-34	Beige
HP-AK	Chalk
HP-8J	Charcoal
HP-3J	Graphite
HP-62	Gray Tone
HP-WL	Linen
HP-3P	Platinum
HP-AA	Putty
HP-3E	Smoke

Patterned

HP-P1	Linen Casual
HP-P2	Linen Classic
HP-P3	Linen Crisp
HP-P4	Linen Flax

Wood Grain

HP-KA	Brazilwood
HP-AM	Cherry
HP-KG	Columbian Walnut
HP-KP	Field Elm
HP-KN	Grey Elm
HP-KM	Landmark Wood
HP-AE	Maple
HP-AD	Medium Cherry
HP-KL	Neo Walnut
HP-KC	New Age Oak
HP-KR	Phantom Ecru
HP-KS	Phantom Pearl
HP-KD	River Cherry
HP-KE	Sanara
HP-KF	Williamsburg Cherry

Ply-Edge

HP-PW	Ply-Edge
-------	----------

Trim

Grade A

Smooth

TR-R	Beige
TR-AK	Chalk
TR-K	Charcoal
TR-C1	Cocoa
TR-J	Graphite
TR-G	Gray Tone
TR-AA	Putty
TR-E	Smoke
TR-PLS	Smooth Plaster
TR-FM	Snow

Textured

TR-TY	Cement
TR-TG	Grout
TR-TF	Pitch
TR-TW	Plaster

Grade B

Smooth

TR-1C	Accent Blue
TR-1D	Accent Green
TR-1E	Accent Orange
TR-1F	Accent Red
TR-1G	Blue Jay
TR-1L	Brindle
TR-1R	Brownstone
TR-CTS	Chartreuse
TR-1N	Night
TR-1Q	Park
TR-RR	Rusty Red
TR-1M	Sable
TR-1P	Seville
TR-1J	Sky Blue
TR-1H	Terra
TR-1K	Wren

Smooth Metallic

TR-DM	Dark Bronze Metallic
TR-MC	Metallic Champagne
TR-LE	Metallic Silver

Textured Metallic

TR-AL	Alloy
TR-AR	Argent
TR-HE	Hellenic

ALERT: These materials are current, however they are being considered for future obsolescence due to low volume.

Forest Stewardship Council (FSC)

Statement:

In our continuing support of sustainable forestry and responsible purchasing, Haworth North America is offering FSC certified wood products at no up-charge. By providing FSC certified material, Haworth is supporting our client's green building goals and demonstrating our collective commitment to source materials more sustainably.

Haworth will provide to you the necessary FSC-certified paperwork with your shipment. For more information, FAQs, and a complete FSC product list (including product exceptions), go to the Library and search FSC.

Executive — A5 Table Finish/Color Legends

Grade BAnegre Quarter Cut

YC-W15	Espresso
YC-W08	Golden
YC-W07	Light

Cherry

YD-CA1	Amber
YD-W23	American
YD-W33	Caramel
YD-W30	Heritage
YD-W32	Pacific

Cherry Quarter Cut

Y2-U	Medium
------	--------

Maple

YL-LM	Light
YL-N	Natural
YL-AD	Sand

Maple Quarter Cut

YM-N	Natural
------	---------

Oak

YO-W05	Natural
--------	---------

Rift Cut White Oak

YB-W15	Espresso
--------	----------

Walnut

YN-W15	Espresso
YN-W31	Retro

Walnut Quarter Cut

Y9-W15	Espresso
Y9-W31	Retro

Grade D

V0-W16	Espresso
V0-W08	Golden
V0-W07	Light

Trim**Grade A**Smooth

TR-R	Beige
TR-AK	Chalk
TR-K	Charcoal
TR-C1	Cocoa
TR-J	Graphite
TR-G	Gray Tone
TR-AA	Putty
TR-E	Smoke
TR-PLS	Smooth Plaster
TR-FM	Snow

Textured

TR-TY	Cement
TR-TG	Grout
TR-TF	Pitch
TR-TW	Plaster

Grade BSmooth

TR-1C	Accent Blue
TR-1D	Accent Green
TR-1E	Accent Orange
TR-1F	Accent Red
TR-1G	Blue Jay
TR-1L	Brindle
TR-1R	Brownstone
TR-CTS	Chartreuse
TR-1N	Night
TR-1Q	Park
TR-RR	Rusty Red
TR-1M	Sable
TR-1P	Seville
TR-1J	Sky Blue
TR-1H	Terra
TR-1K	Wren

Smooth Metallic

TR-DM	Dark Bronze Metallic
TR-MC	Metallic Champagne
TR-LE	Metallic Silver

Textured Metallic

TR-AL	Alloy
TR-AR	Argent
TR-HE	Hellenic

Lock Plugs

TR-BL	Black
TR-BP	Chrome

ALERT: These materials are current, however they are being considered for future obsolescence due to low volume.

Wood:

VR-W12	Naturally
WF-RC	Sorrel Double Cut

Forest Stewardship Council (FSC)**Statement:**

In our continuing support of sustainable forestry and responsible purchasing, Haworth North America is offering FSC certified wood products at no up-charge. By providing FSC certified material, Haworth is supporting our client's green building goals and demonstrating our collective commitment to source materials more sustainably.

Haworth will provide to you the necessary FSC-certified paperwork with your shipment. For more information, FAQs, and a complete FSC product list (including product exceptions), go to the Library and search FSC.

Immerse Table Finish/Color Legends

Wood Finishes

Grade A

Double Cut

2P-RL	Applegate
WL-RL	Beachwood
2R-RL	Butternut
WE-RD	Dune
WJ-RE	Ebony
2N-RL	Echo
2Z-RF	Flint
WE-RT	Melba
2Z-RS	Shale
WC-RW	Wenge

Grade B

Anegre Quarter Cut

YC-W15	Espresso
YC-W08	Golden
YC-W07	Light

Beach

YE-W04	Natural
--------	---------

Cherry

YD-CA1	Amber
YD-W23	American
YD-W33	Caramel
YD-W30	Heritage
YD-W32	Pacific

Cherry Quarter Cut

Y2-U	Medium
------	--------

Maple

YL-LM	Light
YL-N	Natural
YL-AD	Sand

Maple Quarter Cut

YM	Natural
----	---------

Oak

YP-W42	Brindle
YO-W05	Natural

Rift Cut White Oak

YB-W35	Clear
YB-W15	Espresso
YB-W37	Fawn
YB-W40	Mocha
YB-W38	Tuxedo

Walnut

YN-W15	Espresso
YN-W21	Mahogany Stain
YN-W31	Retro

Walnut Quarter Cut

Y9-W35	Clear
Y9-W15	Espresso
Y9-W31	Retro
Y9-W41	Verdant

Paint Top Finishes

Grade A

Solid Color

PW-R	Beige
PW-F	Black
PW-AK	Chalk
PW-G	Gray Tone
PW-PL	Polar
PW-SY	Stormy
PW-VR	Vapor

Grade B

Solid Color

PW-RR	Rusty Red
PW-1J	Sky Blue
PW-SP	Sparrow
PW-ST	Straw
PW-1H	Terra

Laminate Finishes

Grade A

Solid Color

H-34	Beige
H-AK	Chalk
H-8J	Charcoal
H-3J	Graphite
H-62	Gray Tone
H-WL	Linen
H-3P	Platinum
H-AA	Putty
H-3E	Smoke

Wood

H-AM	Amber Cherry
H-AE	Maple
H-AD	Medium Cherry

Grade B

Premium Wood Grain

H-KA	Brazilwood
H-KG	Columbian Walnut
H-KP	Field Elm
H-KN	Grey Elm
H-KM	Landmark Wood
H-KL	Neo Walnut
H-KC	New Age Oak
H-KR	Phantom Ecru
H-KS	Phantom Pearl
H-KD	River Cherry
H-KF	Williamsburg Cherry

Edgeband

Solid Color

HP-34	Beige
HP-AK	Chalk
HP-8J	Charcoal
HP-3J	Graphite
HP-62	Gray Tone
HP-WL	Linen
HP-3P	Platinum
HP-AA	Putty
HP-3E	Smoke

Wood Grain

HP-KA	Brazilwood
HP-AM	Cherry
HP-KG	Columbian Walnut
HP-KP	Field Elm
HP-KN	Grey Elm
HP-KM	Landmark Wood
HP-AE	Maple
HP-AD	Medium Cherry
HP-KL	Neo Walnut
HP-KC	New Age Oak
HP-KR	Phantom Ecru
HP-KS	Phantom Pearl
HP-KD	River Cherry
HP-KF	Williamsburg Cherry

Ply-Edge

HP-PW	Ply-Edge
-------	----------

Solid Surface Top Finish

SS-CW	Cameo White
-------	-------------

Planter Finishes

TR-F	Black
TR-G	Gray Tone
TR-PLS	Smooth Plaster
TR-TC	Terra Cotta

Wood Leg Finishes

M5-W35	Clear on Oak
M6-W35	Clear on Walnut
M7-W43	Ink on Ash

Trim

Grade A

Smooth

TR-R	Beige
TR-AK	Chalk
TR-K	Charcoal
TR-C1	Cocoa
TR-J	Graphite
TR-G	Gray Tone
TR-AA	Putty
TR-E	Smoke
TR-PLS	Smooth Plaster
TR-FM	Snow

Textured

TR-TY	Cement
TR-TG	Grout
TR-TF	Pitch
TR-TW	Plaster

Grade B

Smooth

TR-1C	Accent Blue
TR-1D	Accent Green
TR-1E	Accent Orange
TR-1F	Accent Red
TR-1G	Blue Jay
TR-1L	Brindle
TR-1R	Brownstone
TR-CTS	Chartreuse
TR-1N	Night
TR-1Q	Park
TR-RR	Rusty Red
TR-1M	Sable
TR-1P	Seville
TR-1J	Sky Blue
TR-1H	Terra
TR-1K	Wren

Smooth Metallic

TR-DM	Dark Bronze Metallic
TR-MC	Metallic Champagne
TR-LE	Metallic Silver

Textured Metallic

TR-AL	Alloy
TR-AR	Argent
TR-HE	Hellenic

ALERT: These materials are current, however they are being considered for future obsolescence due to low volume.

Wood:

VR-W21	Mahogany Satin on Walnut
YC-W12	Naturally
2Z-RS	Shale
WF-RC	Sorrel Double Cut

Forest Stewardship Council (FSC) Statement:

In our continuing support of sustainable forestry and responsible purchasing, Haworth North America is offering FSC certified wood products at no up-charge. By providing FSC certified material, Haworth is supporting our client's green building goals and demonstrating our collective commitment to source materials more sustainably.

Haworth will provide to you the necessary FSC-certified paperwork with your shipment. For more information, FAQs, and a complete FSC product list (including product exceptions), go to the Library and search FSC.

Jive Table Finish/Color Legends

Wood Finishes

Grade A

Double Cut

2P-RL	Applegate
WL-RL	Beachwood
2R-RL	Butternut
WE-RD	Dune
WJ-RE	Ebony
2N-RL	Echo
LQ-RH	Hazel Walnut
WE-RT	Melba
WC-RW	Wenge

Grade B

Anegre Quarter Cut

NP-W15	Espresso
NP-W08	Golden
NP-W07	Light

Cherry

VC-CA1	Amber
VC-W23	American
VC-W33	Caramel
VC-W30	Heritage
VC-W32	Pacific

Cherry Quarter Cut

NX-U	Medium
------	--------

Maple

VP-LM	Light
VP-N	Natural
VP-AD	Sand

Maple Quarter Cut

NM-N	Natural
------	---------

Oak

VJ-W42	Brindle
VJ-W05	Natural

Rift Cut White Oak

NR-W35	Clear
NR-W15	Espresso
NR-W37	Fawn
NR-W40	Mocha
NR-W38	Tuxedo

Walnut

VR-W15	Espresso
VR-W21	Mahogany Satin
VR-W31	Retro

Walnut Quarter Cut

NW-W35	Clear
NW-W15	Espresso
NW-W31	Retro
NW-W41	Verdant

Laminate Finishes

Grade A

Solid Color

H-34	Beige
H-AK	Chalk
H-8J	Charcoal
H-3J	Graphite
H-62	Gray Tone
H-WL	Linen
H-3P	Platinum
H-AA	Putty
H-3E	Smoke

Grade A

Patterned

H-P1	Linen Casual
H-P2	Linen Classic
H-P3	Linen Crisp
H-P4	Linen Flax

Edgeband

Solid Color

HP-34	Beige
HP-AK	Chalk
HP-8J	Charcoal
HP-3J	Graphite
HP-62	Gray Tone
HP-WL	Linen
HP-3P	Platinum
HP-AA	Putty
HP-3E	Smoke

Patterned

HP-P1	Linen Casual
HP-P2	Linen Classic
HP-P3	Linen Crisp
HP-P4	Linen Flax

Wood Grain

HP-KA	Brazilwood
HP-AM	Cherry
HP-KG	Columbian Walnut
HP-KP	Field Elm
HP-KN	Grey Elm
HP-KM	Landmark Wood
HP-AE	Maple
HP-AD	Medium Cherry
HP-KL	Neo Walnut
HP-KC	New Age Oak
HP-KR	Phantom Ecru
HP-KS	Phantom Pearl
HP-KD	River Cherry
HP-KE	Sanara
HP-KF	Williamsburg Cherry

Wood

H-AM	Amber Cherry
H-AE	Maple

Grade B

Premium Wood Grain

H-KA	Brazilwood
H-KG	Columbian Walnut
H-KP	Field Elm
H-KN	Grey Elm
H-KM	Landmark Wood
H-KL	Neo Walnut
H-KC	New Age Oak
H-KD	River Cherry
H-KE	Sanara
H-KF	Williamsburg Cherry

Ply-Edge

HP-PW	Ply-Edge
-------	----------

Trim

Grade A

Smooth

TR-K	Charcoal
TR-E	Smoke
TR-PLS	Smooth Plaster

Grade B

Metallic

TR-MC	Champagne
TR-LE	Silver

ALERT: These materials are current, however they are being considered for future obsolescence due to low volume.

Wood:

VR-W12	Naturally
WF-RC	Sorrel Double Cut

Laminate:

H-22	Gray Spex
H-DA	Oats Grain
H-EK	Owl Nest
H-EC	Quail Nest
H-EA	Robin Nest
H-DE	Wheat Grain

Forest Stewardship Council (FSC)

Statement:

In our continuing support of sustainable forestry and responsible purchasing, Haworth North America is offering FSC certified wood products at no up-charge. By providing FSC certified material, Haworth is supporting our client's green building goals and demonstrating our collective commitment to source materials more sustainably.

Haworth will provide to you the necessary FSC-certified paperwork with your shipment. For more information, FAQs, and a complete FSC product list (including product exceptions), go to the Library and search FSC.

Masters Series Table Finish/Color Legends

Wood Finishes

Grade A

Double Cut

2P-RL	Applegate
WL-RL	Beachwood
2R-RL	Butternut
WE-RD	Dune
WJ-RE	Ebony
2N-RL	Echo
LQ-RH	Hazel Walnut
WE-RT	Melba
WC-RW	Wenge

Grade B

Anegre Quarter Cut

NP-W15	Espresso
NP-W08	Golden
NP-W07	Light

Cherry

VC-CA1	Amber
VC-W23	American
VC-W33	Caramel
VC-W30	Heritage
VC-W32	Pacific

Cherry Quarter Cut

NX-U	Medium
------	--------

Maple

VP-LM	Light
VP-N	Natural
VP-AD	Sand

Maple Quarter Cut

NM-N	Natural
------	---------

Oak

VJ-W42	Brindle
VJ-W05	Natural

Rift Cut White Oak

NR-W35	Clear
NR-W15	Espresso
NR-W37	Fawn
NR-W40	Mocha
NR-W38	Tuxedo

Walnut

VR-W15	Espresso
VR-W21	Mahogany Satin
VR-W31	Retro

Walnut Quarter Cut

NW-W35	Clear
NW-W15	Espresso
NW-W31	Retro
NW-W41	Verdant

Laminate Finishes

Grade A

Solid Color

H-34	Beige
H-AK	Chalk
H-8J	Charcoal
H-3J	Graphite
H-62	Gray Tone
H-WL	Linen
H-3P	Platinum
H-AA	Putty
H-3E	Smoke

Grade A

Patterned

H-P1	Linen Casual
H-P2	Linen Classic
H-P3	Linen Crisp
H-P4	Linen Flax

Wood

H-AM	Amber Cherry
H-AE	Maple
H-AD	Medium Cherry

Grade B

Premium Wood Grain

H-KA	Brazilwood
H-KG	Columbian Walnut
H-KP	Field Elm
H-KN	Grey Elm
H-KM	Landmark Wood
H-KL	Neo Walnut
H-KC	New Age Oak
H-KR	Phantom Ecru
H-KS	Phantom Pearl
H-KD	River Cherry
H-KE	Sanara
H-KF	Williamsburg Cherry

Edgeband

Solid Color

HP-34	Beige
HP-AK	Chalk
HP-8J	Charcoal
HP-3J	Graphite
HP-62	Gray Tone
HP-WL	Linen
HP-3P	Platinum
HP-AA	Putty
HP-3E	Smoke

Patterned

HP-P1	Linen Casual
HP-P2	Linen Classic
HP-P3	Linen Crisp
HP-P4	Linen Flax

Wood Grain

HP-KA	Brazilwood
HP-AM	Cherry
HP-KG	Columbian Walnut
HP-KP	Field Elm
HP-KN	Grey Elm
HP-KM	Landmark Wood
HP-AE	Maple
HP-AD	Medium Cherry
HP-KL	Neo Walnut
HP-KC	New Age Oak
HP-KR	Phantom Ecru
HP-KS	Phantom Pearl
HP-KD	River Cherry
HP-KE	Sanara
HP-KF	Williamsburg Cherry

Ply-Edge

HP-PW	Ply-Edge
-------	----------

Trim

Grade A

Smooth

TR-R	Beige
TR-AK	Chalk
TR-K	Charcoal
TR-C1	Cocoa
TR-J	Graphite
TR-G	Gray Tone
TR-AA	Putty
TR-E	Smoke
TR-PLS	Smooth Plaster
TR-FM	Snow

Textured

TR-TY	Cement
TR-TG	Grout
TR-TF	Pitch
TR-TW	Plaster

Grade B

Smooth

TR-1C	Accent Blue
TR-1D	Accent Green
TR-1E	Accent Orange
TR-1F	Accent Red
TR-1G	Blue Jay
TR-1L	Brindle
TR-1R	Brownstone
TR-CTS	Chartreuse
TR-1N	Night
TR-1Q	Park
TR-RR	Rusty Red
TR-1M	Sable
TR-1P	Seville
TR-1J	Sky Blue
TR-1H	Terra
TR-1K	Wren

Smooth Metallic

TR-DM	Dark Bronze Metallic
TR-MC	Metallic Champagne
TR-LE	Metallic Silver

Textured Metallic

TR-AL	Alloy
TR-AR	Argent
TR-HE	Hellenic

ALERT: These materials are current, however they are being considered for future obsolescence due to low volume.

Wood:

VR-W12	Naturally
WF-RC	Sorrel Double Cut

Laminate:

H-DA	Oats Grain
H-EK	Owl Nest
H-EC	Quail Nest
H-EA	Robin Nest
H-DE	Wheat Grain

Forest Stewardship Council (FSC) Statement:

In our continuing support of sustainable forestry and responsible purchasing, Haworth North America is offering FSC certified wood products at no up-charge. By providing FSC certified material, Haworth is supporting our client's green building goals and demonstrating our collective commitment to source materials more sustainably.

Haworth will provide to you the necessary FSC-certified paperwork with your shipment. For more information, FAQs, and a complete FSC product list (including product exceptions), go to the Library and search FSC.

Pip Table Finish/Color Legends

Trim		Surface - Painted MDF	
Grade A		Grade A	
<u>Smooth</u>		PW-R	Beige
TR-R	Beige	PW-F	Black
TR-AK	Chalk	PW-AK	Chalk
TR-K	Charcoal	PW-G	Gray Tone
TR-C1	Cocoa	PW-PL	Polar
TR-J	Graphite	PW-SY	Stormy
TR-G	Gray Tone	PW-VA	Vapor
TR-AA	Putty		
TR-E	Smoke		
TR-PLS	Smooth Plaster	Grade B	
TR-FM	Snow	PW-RR	Rusty Red
		PW-1J	Sky Blue
		PW-SP	Sparrow
		PW-ST	Straw
		PW-1H	Terra
<u>Textured</u>		Surface - Wood	
TR-TY	Cement	VB-W35	Plank White Oak
TR-TG	Grout	VH-W35	Plank Walnut
TR-TF	Pitch		
TR-TW	Plaster		
Grade B			
<u>Smooth</u>			
TR-1C	Accent Blue		
TR-1D	Accent Green		
TR-1E	Accent Orange		
TR-1F	Accent Red		
TR-1G	Blue Jay		
TR-1L	Brindle		
TR-1R	Brownstone		
TR-CTS	Chartreuse		
TR-1N	Night		
TR-1Q	Park		
TR-RR	Rusty Red		
TR-1M	Sable		
TR-1P	Seville		
TR-1J	Sky Blue		
TR-1H	Terra		
TR-1K	Wren		
<u>Smooth Metallic</u>			
TR-DM	Dark Bronze Metallic		
TR-MC	Metallic Champagne		
TR-LE	Metallic Silver		
<u>Textured Metallic</u>			
TR-AL	Alloy		
TR-AR	Argent		
TR-HE	Hellenic		

Planes Table Finish/Color Legends

Wood Finishes

Grade A

Double Cut

2P-RL	Applegate
WL-RL	Beachwood
2R-RL	Butternut
WJ-RE	Ebony
2N-RL	Echo
WE-RD	Dune
WE-RT	Melba
WC-RW	Wenge

Grade B

Anegre Quarter Cut

NP-W15	Espresso
NP-W08	Golden
NP-W07	Light

Cherry

VC-CA1	Amber
VC-W23	American
VC-W33	Caramel
VC-W30	Heritage
VC-W32	Pacific

Cherry Quarter Cut

NX-U	Medium
------	--------

Maple

VP-LM	Light
VP-N	Natural
VP-AD	Sand

Maple Quarter Cut

NM-N	Natural
------	---------

Oak

VJ-W42	Brindle
VJ-W05	Natural

Rift Cut White Oak

NR-W35	Clear
NR-W15	Espresso
NR-W37	Fawn
NR-W40	Mocha
NR-W38	Tuxedo

Walnut

VR-W15	Espresso
VR-W31	Retro

Walnut Quarter Cut

NW-W35	Clear
NW-W15	Espresso
NW-W31	Retro
NW-W41	Verdant

Laminate Finishes

Grade A

Solid Color

H-34	Beige
H-AK	Chalk
H-8J	Charcoal
H-3J	Graphite
H-62	Gray Tone
H-WL	Linen
H-3P	Platinum
H-AA	Putty
H-3E	Smoke

Wood

H-AM	Amber Cherry
H-AE	Maple
H-AD	Medium Cherry

Grade B

Premium Wood Grain

H-KA	Brazilwood
H-KG	Columbian Walnut
H-KP	Field Elm
H-KN	Grey Elm
H-KM	Landmark Wood
H-KL	Neo Walnut
H-KC	New Age Oak
H-KR	Phantom Ecru
H-KS	Phantom Pearl
H-KD	River Cherry
H-KF	Williamsburg Cherry

Grade E

Premium

H-C1	Hay
H-C2	Drift
H-C3	Pecan
H-C4	Molasses
H-C5	Mineral
H-C6	Hatch
H-C7	Tanned

Edgeband

Solid Color

HP-34	Beige
HP-AK	Chalk
HP-8J	Charcoal
HP-3J	Graphite
HP-62	Gray Tone
HP-WL	Linen
HP-3P	Platinum
HP-AA	Putty
HP-3E	Smoke

Wood Grain

HP-KA	Brazilwood
HP-AM	Cherry
HP-KG	Columbian Walnut
HP-KP	Field Elm
HP-KN	Grey Elm
HP-KM	Landmark Wood
HP-AE	Maple
HP-AD	Medium Cherry
HP-KL	Neo Walnut
HP-KC	New Age Oak
HP-KR	Phantom Ecru
HP-KS	Phantom Pearl
HP-KD	River Cherry
HP-KF	Williamsburg Cherry

Ply-Edge

HP-PW	Ply-Edge
-------	----------

Premium

HP-C1	Hay
HP-C2	Drift
HP-C3	Pecan
HP-C4	Molasses
HP-C5	Mineral
HP-C6	Hatch
HP-C7	Tanned

Trim

Grade A

Smooth

TR-R	Beige
TR-AK	Chalk
TR-K	Charcoal
TR-C1	Cocoa
TR-J	Graphite
TR-G	Gray Tone
TR-AA	Putty
TR-E	Smoke
TR-PLS	Smooth Plaster
TR-FM	Snow

Textured

TR-TY	Cement
TR-TG	Grout
TR-TF	Pitch
TR-TW	Plaster

Grade B

Smooth

TR-1C	Accent Blue
TR-1D	Accent Green
TR-1E	Accent Orange
TR-1F	Accent Red
TR-1G	Blue Jay
TR-1L	Brindle
TR-1R	Brownstone
TR-CTS	Chartreuse
TR-1N	Night
TR-1Q	Park
TR-RR	Rusty Red
TR-1M	Sable
TR-1P	Seville
TR-1J	Sky Blue
TR-1H	Terra
TR-1K	Wren

Smooth Metallic

TR-DM	Dark Bronze Metallic
TR-MC	Metallic Champagne
TR-LE	Metallic Silver

Textured Metallic

TR-AL	Alloy
TR-AR	Argent
TR-HE	Hellenic

Casters

TR-F	Black
TR-7	Fog
TR-LPL	Light Platinum

ALERT: These materials are current, however they are being considered for future obsolescence due to low volume.

Wood:

VR-W12	Naturally
WF-RC	Sorrel Double Cut

Laminate:

H-DA	Oats Grain
H-EK	Owl Nest
H-EC	Quail Nest
H-EA	Robin Nest
H-DE	Wheat Grain

Forest Stewardship Council (FSC) Statement:

In our continuing support of sustainable forestry and responsible purchasing, Haworth North America is offering FSC certified wood products at no up-charge. By providing FSC certified material, Haworth is supporting our client's green building goals and demonstrating our collective commitment to source materials more sustainably.

Haworth will provide to you the necessary FSC-certified paperwork with your shipment. For more information, FAQs, and a complete FSC product list (including product exceptions), go to the Library and search FSC.

Planes Table Vertical Fabrics/Color Legend

Vertical Fabrics listed apply to Planes Screens.

• To obtain fabric samples contact your authorized Haworth dealer.

(d) = Directional fabric

(n) = Non-directional fabric

• Fabric and finish availability as well as technical information are subject to change; refer to Surfaces.Haworth.com for current information.

Fabric Grade: A (d)
CHEVRON
**40% Polyester/
 37% Post Industrial
 Recycled Polyester/
 23% Pre Consumer
 Recycled Polyester**
 6X-BR Bargello
 6X-BD Birds
 6X-BS Brown Snail
 6X-FS Featherstitch
 6X-FN Fence
 6X-GR Grillwork
 6X-HR Herringbone
 6X-MN Meander
 6X-PS Pinking Shears
 6X-RR Rickrack
 6X-WV Wavy
 6X-WR Wirble
 6X-ZZ Zigzag

Fabric Grade: A (d)
ETCH
**100% Post Consumer
 Recycled Polyester**
 35-CM Cameo
 35-CA Cartoon
 35-CT Circuit
 35-CR Crayon
 35-DD Doodle
 35-DT Draft
 35-DR Draw
 35-MA Marquette
 35-UT Outline
 35-PA Pastel
 35-PE Pencil
 35-SP Scratch Pad
 35-SK Sketch
 35-TH Thatch
 35-TT Tic Tac

Fabric Grade: A (d)
HIGHLANDS
**100% Recycled Polyester
 (100% REPREVE®)**
 L6-AG Glen
 L6-AH Heather
 L6-AL Loch
 L6-AM Moor
 L6-AP Peat
 L6-AT Thatch

Fabric Grade: A (d)
IOWA
**52% Post Industrial
 Recycled Polyester/
 48% Post Consumer
 Recycled Polyester**
 FZ-10 Badger
 FZ-6 Bixby
 FZ-3 Bobwhite
 FZ-2 Cedar Rock
 FZ-11 Clear Lake
 FZ-13 Emerson
 FZ-7 Gar
 FZ-9 Honeycreek
 FZ-1 Manawa
 FZ-5 Rice Lake
 FZ-4 Trappers Bay
 FZ-12 Walnut Woods
 FZ-8 Wapello

Fabric Grade: A (d)
POINT
100% Polyester
 EE-AG Compass
 EE-AC Decimal
 EE-AF Focal
 EE-AD Nib
 EE-AA Peak
 EE-AE Vertex

Fabric Grade: A (d)
STRIAE
**42% Post Industrial
 Recycled Polyester/
 42% Post Consumer
 Recycled Polyester/
 16% Polyester
 (84% REPREVE®)**
 C1-AM Band
 C1-AJ Beam
 C1-AH Element
 C1-AF Fillet
 C1-AC Moonlight
 C1-AE Ray
 C1-AK Ribbon
 C1-AD Straws
 C1-AA Stream
 C1-AL Trace

Fabric Grade A (d)
TAILORED
**100% Post Consumer
 Recycled Polyester**
 PY-AL Alter
 PY-BU Buttons
 PY-DR Draper
 PY-FC French Chalk
 PY-HE Hem
 PY-MA Mannequin
 PY-SE Seam
 PY-SH Shears
 PY-SU Suit
 PY-TH Thread
 PY-TR Tradition

Fabric Grade: A (n)
TELLURE
100% Polyester
 3A-31 Aegean
 3A-18 Black
 3A-45 Buff
 3A-53 Cayenne
 3A-40 Chocolate
 3A-49 Dove
 3A-28 Dynamo
 3A-54 Goose
 3A-23 Jodhpurs
 3A-33 Miami
 3A-19 Navy
 3A-06 Nickel
 3A-34 Ocean
 3A-46 Parrot
 3A-50 Peel
 3A-47 Pumpkin
 3A-44 Roan
 3A-51 Rust
 3A-37 Spring
 3A-48 Sprout
 3A-52 Sunset
 3A-43 Tomato

Fabric Grade: B (d)
CAMP
**100% Post Consumer
 Recycled Polyester**
 33-CF Campfire
 33-CA Canoe
 33-CT Cot
 33-DK Docks
 33-FF Firefly
 33-FR Forest
 33-GR Granola
 33-GL Grill
 33-JA Jamboree
 33-PD Pond
 33-RA Rain
 33-SC Scout
 33-SM Smore
 33-TE Tent

Fabric Grade: B (d)
CLASSIC
**82% Recycled Polyester/
 18% Polyester
 (82% REPREVE®)**
 L5-AJ Art
 L5-AG Car
 L5-AF Comedy
 L5-AR Dance
 L5-AH Design
 L5-AD Drama
 L5-AT Movie
 L5-AA Musical
 L5-AC Radio
 L5-AS Song

Fabric Grade: B (d)
FIELDS
**50% Post Consumer
 Recycled Polyester/
 50% Virgin Polyester**
 34-AL Alfalfa
 34-BB Blueberry
 34-CN Corn
 34-CT Cotton
 34-OA Oats
 34-PL Plow
 34-PR Prairie
 34-PK Pumpkin
 34-SC Scarecrow
 34-SY Soy
 34-ST Strawberry
 34-TL Till
 34-WH Wheat

Fabric Grade: B (d)
HUE
**62% Antimony Free Polyester/
 38% Virgin Polyester**
 6-BK Bark
 6-ED Eddy
 6-FR Froth
 6-GK Ginko
 6-LT Latte
 6-LF Leaf
 6-LM Lemon
 6-MG Marigold
 6-MR Marine
 6-PP Poppy
 6-RD Red
 6-SS Seaside
 6-SP Spring
 6-ST Steam
 6-TQ Turquoise
 6-WP Wisp

Fabric Grade: B (d)
KIO
100% Recycled Polyester
 ZR-6 Bennett
 ZR-8 Cascade
 ZR-7 Crew
 ZR-5 FUD
 ZR-3 Jeanlin
 ZR-1 Jib
 ZR-11 Reeds Lake
 ZR-13 Regatta
 ZR-10 Sailor
 ZR-2 Sentra
 ZR-12 Smurf
 ZR-9 TSJ
 ZR-4 Yippi Kio

Planes Table Vertical Fabrics/Color Legend

Fabric Grade: B (d)
PECA**51% Virgin Polyester/
49% Antimony Free
Polyester**

32-BE	Bead
32-CH	Chip
32-DT	Dots
32-EL	Elfin
32-JT	Jot
32-MN	Minnow
32-MS	Mouse
32-PW	Pee Wee
32-SE	Seed
32-SM	Smidge
32-TA	Tad
32-TT	Title
32-TR	Trifle
32-TY	Tyne

Fabric Grade: B (d)
REVERB**100% Post Consumer
Recycled Polyester**

3V-BM	Boomy
3V-BN	Bounce
3V-CR	Crackle
3V-EC	Echo
3V-GN	Gong
3V-HA	Harmonics
3V-MG	Moog
3V-MR	Murmur
3V-PN	Ping
3V-RF	Rifts
3V-RN	Ring
3V-SN	Snare
3V-SC	Sonic
3V-SY	Synth
3V-TM	Timbers
3V-WF	Waft

Fabric Grade B (d)
RITZ**49% Post Industrial
Recycled Polyester/
51% Post Consumer
Recycled Polyester
(51% REPREVE®)**

PV-BR	Bravo
PV-BT	Black Tie
PV-CA	Candle Light
PV-CH	Champagne
PV-CL	Classy
PV-CT	Class Act
PV-FR	Formal
PV-VA	Ovation
PV-WT	White Tie

Fabric Grade: B (d)
SHIMMER**100% Recycled Polyester**

WS-5	Cellophane
WS-8	Copper
WS-13	Dew
WS-14	Diamond
WS-9	Flaxen
WS-4	Gems
WS-11	Glass
WS-1	Glitter
WS-10	Mirage
WS-16	Mirror
WS-2	Moonlight
WS-6	Puddle
WS-15	Reflection
WS-12	Stars
WS-3	Water
WS-7	Wet Grass

Fabric Grade C (d)
BIRDS NEST**38% Post Industrial
Recycled Polyester/
20% Post Consumer
Recycled Polyester/
42% Recycled Polyester
(20% REPREVE®)**

PH-CA	Canary
PH-EA	Eagle
PH-EG	Egret
PH-FA	Falcon
PH-HE	Heron
PH-HU	Hummingbird
PH-MD	Morning Dove
PH-NU	Nuthatch
PH-WL	Owl
PH-RA	Raven
PH-SA	Sandpiper
PH-ST	Stork
PH-SW	Swan

Fabric Grade C (d)
GEODE**34% Post Industrial
Recycled Polyester/
26% Post Consumer
Recycled Polyester/
40% Recycled Polyester
(26% REPREVE®)**

PR-BS	Bismuth
PR-CA	Calcite
PR-CT	Citrine
PR-CR	Crystal
PR-FL	Fluorite
PR-GA	Galena
PR-HL	Hollow
PR-MA	Malachite
PR-QU	Quartz
PR-WN	Wonder

Fabric Grade C (d)
SISAL**57% Repeve Polyester/
43% Virgin Polyester**

SW-AL	Alder
SW-AS	Ash
SW-BC	Buckhorn
SW-CT	Cutch
SW-BB	Gibbsite
SW-ND	Indigo
SW-KN	Knotweed
SW-LC	Lichen
SW-PL	Plant
SW-LL	Quill
SW-RB	Rubia
SW-WL	Walnut

Fabric Grade: C (d)
THORMAN**48% Post Industrial
Recycled Polyester/
26% Post Consumer
Recycled 26% Polyester**

45-DR	Dryden
45-EC	Eclipse
45-FR	Farm
45-FL	Flamingo
45-HS	Hope St
45-KV	Kevin
45-MR	Martini
45-SM	Sam
45-TH	Theatre

Fabric Grade: D (d)
TANGRAM**57% Polyester/
28% Post Industrial
Recycled Polyester/
15% Post Consumer
Recycled Polyester**

LV-CL	Clue
LV-EN	Enigma
LV-GU	Guess
LV-MA	Maze
LV-MU	Muse
LV-MT	Mystery
LV-MY	Mystify
LV-UT	Outline
LV-PE	Perplex
LV-PC	Pieces
LV-PU	Puzzle
LV-RD	Riddle
LV-SC	Scrabble
LV-SL	Solve
LV-TE	Teaser
LV-TR	Trick

ALERT: These materials are current,
however they are being considered for
future obsolescence due to low volume.**Fabric Grade: A** (d)
SAVOY**51% Virgin Polyester/
49% Recycled Polyester**

FJ-CC	Apache
FJ-AD	Balsam
FJ-AP	Bisque
FJ-AE	Blue Ridge
FJ-AA	Blue Willow
FJ-CA	Breaker
FJ-AR	Chamois
FJ-AK	Elephant
FJ-AL	Glacier
FJ-AX	Mango
FJ-AY	Maya
FJ-AW	Poplar
FJ-CD	Raisen
FJ-AT	Shallot
FJ-AM	Stainless
FJ-AF	Tempest

Fabric Grade: A (d)
TATAMI**100% Polyester**

W5-1	Agave
W5-2	Coir
W5-3	Geta
W5-4	Hemp
W5-5	Jute
W5-6	Kayar
W5-7	Kobe
W5-8	Saffron
W5-9	Sapporo
W5-10	Sisal
W5-12	Tabi
W5-11	Tesori

Fabric Grade A (d)
TUSCAN**65% Post Industrial
Recycled Polyester/
35% Post Consumer
Recycled Polyester
(35% REPREVE®)**

TK-AR	Arno
TK-CA	Carrara
TK-DA	David
TK-ET	Etruscan
TK-FL	Florence
TK-LM	Limoncello
TK-MA	Masonry
TK-ME	Medici
TK-TR	Olive Tree
TK-PS	Pisa
TK-RM	Romanesque
TK-RU	Rustic
TK-SE	Siena

Fabric Grade: B (d)
LANDSCAPE**100% Recycled Polyester**

C2-AD	Estate
C2-AH	Harvest
C2-AJ	Panorama
C2-AF	Parkland
C2-AC	Photograph
C2-AE	Seascape
C2-AA	Vista

Fabric Grade: B (n)
PUZZLER**48% Post Industrial
Recycled Polyester/
52% Post Consumer
Recycled Polyester**

7L-C	Clue
7L-CR	Cryptic
7L-E	Enigma
7L-I	Intrigue
7L-M	Maze
7L-R	Riddle

Fabric Grade: B (d)
TRAFFIC**24% Post Industrial
Recycled Polyester/
76% Post Consumer
Recycled Polyester**

WZ-9	Autobon
WZ-6	Country Drive
WZ-7	Freeway
WZ-5	Gridlock
WZ-1	Jam
WZ-3	Merge
WZ-8	Route 66
WZ-4	Ticket
WZ-2	Yield

Haworth AllianceFor information on Haworth Alliance Program,
please refer to:
surfaces.haworth.com**Customer's Own Material (COM)**For Customer's Own Material (COM) information
including requesting a new COM, please refer to:
surfaces.haworth.com

PopUp Table Finish/Color Legends

Wood Finishes

Grade A

Double Cut

2P-RL	Applegate
WL-RL	Beachwood
2R-RL	Butternut
WJ-RE	Ebony
2N-RL	Echo
LQ-RH	Hazel Walnut
WE-RT	Melba
WC-RW	Wenge

Grade B

Anegre Quarter Cut

NP-W15	Espresso
NP-W08	Golden
NP-W07	Light

Cherry

VC-CA1	Amber
VC-W23	American
VC-W33	Caramel
VC-W30	Heritage
VC-W32	Pacific

Cherry Quarter Cut

NX-U	Medium
------	--------

Maple

VP-LM	Light
VP-N	Natural
VP-AD	Sand

Maple Quarter Cut

NM-N	Natural
------	---------

Oak

VJ-W42	Brindle
VJ-W05	Natural

Rift Cut White Oak

NR-W35	Clear
NR-W15	Espresso
NR-W37	Fawn
NR-W40	Mocha
NR-W38	Tuxedo

Walnut

VR-W15	Espresso
VR-W21	Mahogany Satin
VR-W31	Retro

Walnut Quarter Cut

NW-W35	Clear
NW-W15	Espresso
NW-W31	Retro
NW-W41	Verdant

Laminate Finishes

Grade A

Solid Color

H-34	Beige
H-AK	Chalk
H-8J	Charcoal
H-3J	Graphite
H-62	Gray Tone
H-WL	Linen
H-3P	Platinum
H-AA	Putty
H-3E	Smoke

Grade A

Patterned

H-P1	Linen Casual
H-P2	Linen Classic
H-P3	Linen Crisp
H-P4	Linen Flax

Wood

H-AM	Amber Cherry
H-AE	Maple
H-AD	Medium Cherry

Grade B

Premium Wood Grain

H-KA	Brazilwood
H-KG	Columbian Walnut
H-KP	Field Elm
H-KN	Grey Elm
H-KM	Landmark Wood
H-KL	Neo Walnut
H-KC	New Age Oak
H-KR	Phantom Ecru
H-KS	Phantom Pearl
H-KD	River Cherry
H-KE	Sanara
H-KF	Williamsburg Cherry

Edgeband

Solid Color

HP-34	Beige
HP-AK	Chalk
HP-8J	Charcoal
HP-3J	Graphite
HP-62	Gray Tone
HP-WL	Linen
HP-3P	Platinum
HP-AA	Putty
HP-3E	Smoke

Patterned

HP-P1	Linen Casual
HP-P2	Linen Classic
HP-P3	Linen Crisp
HP-P4	Linen Flax

Wood Grain

HP-KA	Brazilwood
HP-AM	Cherry
HP-KG	Columbian Walnut
HP-KP	Field Elm
HP-KN	Grey Elm
HP-KM	Landmark Wood
HP-AE	Maple
HP-AD	Medium Cherry
HP-KL	Neo Walnut
HP-KC	New Age Oak
HP-KR	Phantom Ecru
HP-KS	Phantom Pearl
HP-KD	River Cherry
HP-KE	Sanara
HP-KF	Williamsburg Cherry

Ply-Edge

HP-PW	Ply-Edge
-------	----------

Trim

Grade A

Smooth

TR-R	Beige
TR-AK	Chalk
TR-K	Charcoal
TR-C1	Cocoa
TR-J	Graphite
TR-G	Gray Tone
TR-AA	Putty
TR-E	Smoke
TR-PLS	Smooth Plaster
TR-FM	Snow

Textured

TR-TY	Cement
TR-TG	Grout
TR-TF	Pitch
TR-TW	Plaster

Grade B

Smooth

TR-1C	Accent Blue
TR-1D	Accent Green
TR-1E	Accent Orange
TR-1F	Accent Red
TR-1G	Blue Jay
TR-1L	Brindle
TR-1R	Brownstone
TR-CTS	Chartreuse
TR-1N	Night
TR-1Q	Park
TR-RR	Rusty Red
TR-1M	Sable
TR-1P	Seville
TR-1J	Sky Blue
TR-1H	Terra
TR-1K	Wren

Smooth Metallic

TR-DM	Dark Bronze Metallic
TR-MC	Metallic Champagne
TR-LE	Metallic Silver

Textured Metallic

TR-AL	Alloy
TR-AR	Argent
TR-HE	Hellenic

ALERT: These materials are current, however they are being considered for future obsolescence due to low volume.

Forest Stewardship Council (FSC)

Statement:

In our continuing support of sustainable forestry and responsible purchasing, Haworth North America is offering FSC certified wood products at no up-charge. By providing FSC certified material, Haworth is supporting our client's green building goals and demonstrating our collective commitment to source materials more sustainably.

Haworth will provide to you the necessary FSC-certified paperwork with your shipment. For more information, FAQs, and a complete FSC product list (including product exceptions), go to the Library and search FSC.

PREMISE Table Finish/Color Legends

Wood Finishes

Grade A

Double Cut

2P-RL	Applegate
WL-RL	Beachwood
2R-RL	Butternut
WE-RD	Dune
WJ-RE	Ebony
2N-RL	Echo
LQ-RH	Hazel Walnut
WE-RT	Melba
WC-RW	Wenge

Grade B

Anegre Quarter Cut

NP-W15	Espresso
NP-W08	Golden
NP-W07	Light

Cherry

VC-CA1	Amber
VC-W23	American
VC-W33	Caramel
VC-W30	Heritage
VC-W32	Pacific

Cherry Quarter Cut

NX-U	Medium
------	--------

Maple

VP-LM	Light
VP-N	Natural
VP-AD	Sand

Maple Quarter Cut

NM-N	Natural
------	---------

Oak

VJ-W42	Brindle
VJ-W05	Natural

Rift Cut White Oak

NR-W35	Clear
NR-W15	Espresso
NR-W37	Fawn
NR-W40	Mocha
NR-W38	Tuxedo

Walnut

VR-W15	Espresso
VR-W21	Mahogany Satin
VR-W31	Retro

Walnut Quarter Cut

NW-W35	Clear
NW-W15	Espresso
NW-W31	Retro
NW-W41	Verdant

Laminate Finishes

Grade A

Solid Color

H-34	Beige
H-AK	Chalk
H-8J	Charcoal
H-3J	Graphite
H-62	Gray Tone
H-WL	Linen
H-3P	Platinum
H-AA	Putty
H-3E	Smoke

Grade A

Patterned

H-P1	Linen Casual
H-P2	Linen Classic
H-P3	Linen Crisp
H-P4	Linen Flax

Wood

H-AM	Amber Cherry
H-AE	Maple
H-AD	Medium Cherry

Grade B

Premium Wood Grain

H-KA	Brazilwood
H-KG	Columbian Walnut
H-KP	Field Elm
H-KN	Grey Elm
H-KM	Landmark Wood
H-KL	Neo Walnut
H-KC	New Age Oak
H-KR	Phantom Ecru
H-KS	Phantom Pearl
H-KD	River Cherry
H-KE	Sanara
H-KF	Williamsburg Cherry

Edgeband

Solid Color

HP-34	Beige
HP-AK	Chalk
HP-8J	Charcoal
HP-3J	Graphite
HP-62	Gray Tone
HP-WL	Linen
HP-3P	Platinum
HP-AA	Putty
HP-3E	Smoke

Patterned

HP-P1	Linen Casual
HP-P2	Linen Classic
HP-P3	Linen Crisp
HP-P4	Linen Flax

Wood Grain

HP-KA	Brazilwood
HP-AM	Cherry
HP-KG	Columbian Walnut
HP-KP	Field Elm
HP-KN	Grey Elm
HP-KM	Landmark Wood
HP-AE	Maple
HP-AD	Medium Cherry
HP-KL	Neo Walnut
HP-KC	New Age Oak
HP-KR	Phantom Ecru
HP-KS	Phantom Pearl
HP-KD	River Cherry
HP-KE	Sanara
HP-KF	Williamsburg Cherry

Trim

Grade A

Smooth

TR-R	Beige
TR-AK	Chalk
TR-K	Charcoal
TR-C1	Cocoa
TR-J	Graphite
TR-G	Gray Tone
TR-AA	Putty
TR-E	Smoke
TR-PLS	Smooth Plaster
TR-FM	Snow

Textured

TR-TY	Cement
TR-TG	Grout
TR-TF	Pitch
TR-TW	Plaster

Grade B

Smooth

TR-1C	Accent Blue
TR-1D	Accent Green
TR-1E	Accent Orange
TR-1F	Accent Red
TR-1G	Blue Jay
TR-1L	Brindle
TR-1R	Brownstone
TR-CTS	Chartreuse
TR-1N	Night
TR-1Q	Park
TR-RR	Rusty Red
TR-1M	Sable
TR-1P	Seville
TR-1J	Sky Blue
TR-1H	Terra
TR-1K	Wren

Smooth Metallic

TR-DM	Dark Bronze Metallic
TR-MC	Metallic Champagne
TR-LE	Metallic Silver

Textured Metallic

TR-AL	Alloy
TR-AR	Argent
TR-HE	Hellenic

ALERT: These materials are current, however they are being considered for future obsolescence due to low volume.

Wood:

VR-W12	Naturally
WF-RC	Sorrel Double Cut

Laminate:

H-DA	Oats Grain
H-EK	Owl Nest
H-EC	Quail Nest
H-EA	Robin Nest
H-DE	Wheat Grain

Forest Stewardship Council (FSC) Statement:

In our continuing support of sustainable forestry and responsible purchasing, Haworth North America is offering FSC certified wood products at no up-charge. By providing FSC certified material, Haworth is supporting our client's green building goals and demonstrating our collective commitment to source materials more sustainably.

Haworth will provide to you the necessary FSC-certified paperwork with your shipment. For more information, FAQs, and a complete FSC product list (including product exceptions), go to the Library and search FSC.

Reside Table Finish/Color Legends

Wood Finishes**Grade A**Double Cut

2P-RL	Applegate
WL-RL	Beachwood
2R-RL	Butternut
WE-RD	Dune
WJ-RE	Ebony
2N-RL	Echo
LQ-RH	Hazel Walnut
WE-RT	Melba
WC-RW	Wenge

Grade BAnegre Quarter Cut

NP-W15	Espresso
NP-W08	Golden
NP-W07	Light

Cherry

VC-CA1	Amber
VC-W23	American
VC-W33	Caramel
VC-W30	Heritage
VC-W32	Pacific

Cherry Quarter Cut

NX-U	Medium
------	--------

Maple

VP-LM	Light
VP-N	Natural
VP-AD	Sand

Maple Quarter Cut

NM-N	Natural
------	---------

Oak

VJ-W42	Brindle
VJ-W05	Natural

Rift Cut White Oak

NR-W35	Clear
NR-W15	Espresso
NR-W37	Fawn
NR-W40	Mocha
NR-W38	Tuxedo

Walnut

VR-W15	Espresso
VR-W21	Mahogany Satin
VR-W31	Retro

Walnut Quarter Cut

NW-W35	Clear
NW-W15	Espresso
NW-W31	Retro
NW-W41	Verdant

Laminate Finishes**Grade A**Solid Color

H-34	Beige
H-AK	Chalk
H-8J	Charcoal
H-3J	Graphite
H-62	Gray Tone
H-WL	Linen
H-3P	Platinum
H-AA	Putty
H-3E	Smoke

Grade APatterned

H-P1	Linen Casual
H-P2	Linen Classic
H-P3	Linen Crisp
H-P4	Linen Flax

Wood

H-AM	Amber Cherry
H-AE	Maple
H-AD	Medium Cherry

Grade BPremium Wood Grain

H-KA	Brazilwood
H-KG	Columbian Walnut
H-KP	Field Elm
H-KN	Grey Elm
H-KM	Landmark Wood
H-KL	Neo Walnut
H-KC	New Age Oak
H-KR	Phantom Ecru
H-KS	Phantom Pearl
H-KD	River Cherry
H-KE	Sanara
H-KF	Williamsburg Cherry

EdgebandSolid Color

HP-34	Beige
HP-AK	Chalk
HP-8J	Charcoal
HP-3J	Graphite
HP-62	Gray Tone
HP-WL	Linen
HP-3P	Platinum
HP-AA	Putty
HP-3E	Smoke

Patterned

HP-P1	Linen Casual
HP-P2	Linen Classic
HP-P3	Linen Crisp
HP-P4	Linen Flax

Wood Grain

HP-KA	Brazilwood
HP-AM	Cherry
HP-KG	Columbian Walnut
HP-KP	Field Elm
HP-KN	Grey Elm
HP-KM	Landmark Wood
HP-AE	Maple
HP-AD	Medium Cherry
HP-KL	Neo Walnut
HP-KC	New Age Oak
HP-KR	Phantom Ecru
HP-KS	Phantom Pearl
HP-KD	River Cherry
HP-KE	Sanara
HP-KF	Williamsburg Cherry

Trim**Grade A**Smooth

TR-R	Beige
TR-AK	Chalk
TR-K	Charcoal
TR-C1	Cocoa
TR-J	Graphite
TR-G	Gray Tone
TR-AA	Putty
TR-E	Smoke
TR-PLS	Smooth Plaster
TR-FM	Snow

Textured

TR-TY	Cement
TR-TG	Grout
TR-TF	Pitch
TR-TW	Plaster

Grade BSmooth

TR-1C	Accent Blue
TR-1D	Accent Green
TR-1E	Accent Orange
TR-1F	Accent Red
TR-1G	Blue Jay
TR-1L	Brindle
TR-1R	Brownstone
TR-CTS	Chartreuse
TR-1N	Night
TR-1Q	Park
TR-RR	Rusty Red
TR-1M	Sable
TR-1P	Seville
TR-1J	Sky Blue
TR-1H	Terra
TR-1K	Wren

Smooth Metallic

TR-DM	Dark Bronze Metallic
TR-MC	Metallic Champagne
TR-LE	Metallic Silver

Textured Metallic

TR-AL	Alloy
TR-AR	Argent
TR-HE	Hellenic

ALERT: These materials are current, however they are being considered for future obsolescence due to low volume.

Wood:

VR-W12	Naturally
WF-RC	Sorrel Double Cut

Laminate:

H-DH	Barley Grain
H-22	Gray Spex
H-AD	Medium Cherry
H-DA	Oats Grain
H-EK	Owl Nest
H-EC	Quail Nest
H-ED	Rhea Nest
H-EA	Robin Nest
H-DE	Wheat Grain
H-21	White Spex

Forest Stewardship Council (FSC)**Statement:**

In our continuing support of sustainable forestry and responsible purchasing, Haworth North America is offering FSC certified wood products at no up-charge. By providing FSC certified material, Haworth is supporting our client's green building goals and demonstrating our collective commitment to source materials more sustainably.

Haworth will provide to you the necessary FSC-certified paperwork with your shipment. For more information, FAQs, and a complete FSC product list (including product exceptions), go to the Library and search FSC.

North American Terms of Sale

These Terms of Sale are part of a quotation, bid response, or other sales document issued by Haworth, Inc., Haworth, Ltd. ("Haworth").

These Terms of Sale do not cover products manufactured in North America shipping to non-North American countries nor do they cover products manufactured in non-North American countries shipping to North America. For those terms of sale, please contact Haworth's Global Trade and Compliance Department at 616.393.3000 or through Haworth.com.

A. Ordering Information

Haworth sells its products on the terms set forth in these standard Terms of Sale:

ORDERS MUST BE SUBMITTED IN WRITING OR ELECTRONICALLY (Lynx) AS REPRESENTED BY A VALID PURCHASE ORDER, WHICH INCLUDES PRODUCT TOTAL.

An order is not binding upon Haworth until Haworth issues an order acknowledgment to the customer (the "Customer"), which will include price information and an anticipated delivery date.

1. Order Changes/Cancellations

For Specials, Customer's Own Material (C.O.M.), finish matches, custom colors, custom products, Master lock and key orders, and RUSH orders, no changes or cancellations are allowed 24 hours after order placement. All other products require approval for changes or cancellations. A change/cancellation fee may apply. Contact Order Services for applicable charges.

Ship-to addresses changed within five (5) business days of delivery will incur fees to cover administrative costs due to re-labeling of product and/or reconsignment fees with the carrier.

Order cancellations are complete annulments of orders. Order changes are the deletion of line items or a change in size, color, quantity, ship-to address, or scope of work. There is no penalty for additions; however, any change may cause the order or the line items affected to be rescheduled. Order changes involving additional product and services which increase the value must be accompanied by an amended Purchase Order or other document as agreed.

ALL CHANGES MUST BE IN WRITING, REGARDLESS OF THE (DOLLAR) VALUE. CHANGES ARE NOT BINDING UPON HAWORTH UNTIL HAWORTH ISSUES AN ACKNOWLEDGMENT OF THE CHANGE.

2. C.O.M. (Customer's Own Material)

A Customer who requests a fabric, surface or finish material (C.O.M.) not in Haworth's standard finish offering must first confirm approval of or request new approval for the C.O.M.

Haworth will determine feasibility of the material for manufacturability. For a description of the procedure to submit C.O.M. samples, contact Haworth's Order Services department. For testing information, see the C.O.M. section of the catalog, or call Haworth Order Services.

If Haworth agrees to use the C.O.M., (1) Haworth shall have no responsibility for the condition, quality, value, performance, physical properties, or any other aspect of the C.O.M.; and (2) Haworth shall have no liability for any damages, injuries, or losses to the Customer or to any third party that shall be caused by any C.O.M., and the Customer shall hold Haworth harmless for all such liability.

3. Valid/Complete Purchase Order

The following information is required in order to process an order with Haworth:

a. Customer Information

- i. **Sold To:** Legal name, complete address (if Haworth is to bill the end user, provide end user Purchase Order made out to Haworth, Inc., Haworth, Ltd.) and phone and fax number.
- ii. **Ship To:** Legal name and address.
- iii. **Purchase Order Number:** From the party Haworth will be billing.
- iv. **Authorized Signature:** All Purchase Orders must be signed by a duly authorized representative if a signature line is present. Electronically transmitted Purchase Orders will be accepted without a signature if dealer billed and the dealer has an electronic purchase payment agreement on file.
- v. **Contact Name and Phone Number:** Person Haworth should contact with any questions regarding the order.
- vi. **Shipping Contact:** Name and phone number of person to be contacted regarding shipping and delivery matters.
- vii. **Tagging Instructions:** This information will appear on all documentation received from Haworth including: cartons, acknowledgments, and invoices.
- viii. **Price Agreement or National Sales Agreement Number**
- ix. **Product Total:** Net dollars.
- x. **Installation, Design, Project Management, and/or Service Fees**

b. Product Information

- i. **Quantity**
- ii. **Product Numbers**
- iii. **Colors**
- iv. **Specials:** Specify special part number for new special products.
- v. **Customer's Own Material:** Order entry code, manufacturer, pattern, and color.

- vi. **Approval Drawings:** An authorized signature by a duly authorized representative is required for shop drawings when applicable.
- vii. A deposit may be required for custom materials.

c. Order Confirmation

All orders will be acknowledged.

B. Pricing Policies

1. Terms of Payment

Terms of payment and credit limits will be established based on financial information. Standard payment terms on open credit are net thirty (30) days from invoice date. Advance payments or other payment security may be required by Haworth. The account balance must be at or below the credit limit and current at all times (no past-due balances). Haworth reserves the right to delay or cancel any delivery to a Customer whose Haworth account balance is over the credit limit and/or past due. For walls and floors a deposit will be required.

2. Terms of Credit

Customer hereby authorizes Haworth to obtain such credit reports, financial information or other information as Haworth may request, including, without limitation, credit information from any financial institutions or others having a business relationship with the Customer. Customer hereby authorizes any credit references to answer Haworth's inquiries and provide such credit information and documentation as Haworth may request.

The Customer hereby releases and holds Haworth harmless for any inconvenience whatsoever, caused by any temporary or permanent withdrawal or restriction of credit privileges hereunder, or the enforcement of any of the provisions contained in this paragraph.

3. Past-Due Charges

Past-due balances will be increased by a maximum of 1.5% per month, or 18% annually, without forfeit of Haworth's right to immediate payment.

4. Applicable Prices

The price of any product sold to Customer by Haworth will be based upon the North American Price List (Catalog).

Prices and discounts are subject to change without notice or approval. In the event of an adjustment to pricing, National Sales Agreement (NSA) Customers will be notified in advance according to the terms of the NSA.

Applicable prices and currency exchange rates are those in effect at the time of the RECEIPT of an ORDER; Haworth reserves the right to use the published pricing effective at the time of shipment, if the requested delivery date is more than 120 days after the order receipt date.

North American Terms of Sale

Haworth Flooring products are sold using the North American price list in US dollars. Currency exchange rates at the time of the transaction will be used to convert the USD amount into the alternate currency. Should the currency exchange rate between the USD and alternate currency change between a quote and the receipt of an order, the alternate currency amount will also change to equal the current, equivalent USD amount.

5. C.O.M. (Customer's Own Material) Charges

Refer to appropriate Customer's Own Material (C.O.M.) form for applicable surface material charges.

6. Taxes

Haworth prices do not include customs duty, sales, use, value added or similar taxes. Any federal, state/provincial or other taxes or assessments based upon the sale or delivery of products or services sold applicable to the customer at present or later imposed by federal, state/provincial or municipal agencies, shall be added and paid by the customer. Customer is responsible for all such taxes.

NOTE: For all countries a valid sales tax exemption certificate must be approved by and on file with Haworth prior to product shipment. Otherwise, sales tax will be due and payable to Haworth when such tax is invoiced to Customer.

7. Services

If, as a result of Customer request, the Haworth dealer or Haworth subsidiary provides planning/design services, storage, project management, special handling, set-up, installation and/or other services, the Customer will be charged at the local Haworth dealer/subsidiary's prevailing rates.

8. Termination by Haworth

Haworth may immediately terminate an order upon written notice in the event bankruptcy or insolvency proceedings are instituted by or against the Customer, or the Customer is adjudicated as bankrupt, becomes insolvent, makes an assignment for the benefit of creditors, or proposes or makes any arrangements for the liquidation of its debts, or a receiver or receiver and manager is appointed with respect to all or any part of the assets of the Customer.

C. Shipping and Delivery

Haworth will have the right to determine the method of shipment and routing of product.

If, for any reason, a delivery has to be made to an intermediate location (i.e. a location other than the "Ship To" location noted on the order or ultimate end user location), all handling and re-delivery costs incurred would be at the Customer's expense.

1. U.S.A. - Contiguous

All deliveries will be CPT (Carriage Paid To) (ICC Incoterms 2010) Haworth's manufacturing facilities or distribution centers. Freight charges will be prepaid by Haworth on all orders to locations within the continental United States. Customer bears all risk of loss or damage to the goods when they are placed on Haworth's means of transport.

2. U.S.A. - Non-contiguous (Alaska, Hawaii and Puerto Rico)

All deliveries will be CIF (Cost, Insurance and Freight) (ICC Incoterms 2010). Haworth's catalog prices include ocean freight and insurance to the port of the final destination. Haworth has the right to determine the carrier, method of shipment and routing. Haworth will contract with the insurer and provide minimal insurance coverage (CIF @ 110%) made payable to the Customer. Customer is responsible to obtain greater insurance if so desired.

Customer bears all risk of loss or damage to the goods when the goods are effectively at the disposal of the Customer on board the vessel at the named port of destination. Proof of delivery is a clean on board bill of lading. Customer will be responsible for all on-carriage from the receiving port to the final destination.

3. Canada

All deliveries will be DDP (Delivered Duty Paid) (ICC Incoterms 2010). Haworth's catalog prices include delivery to Customer's named place, not unloaded from any arriving means of transport. Customer bears all risk of loss or damage to the goods when they are delivered to the Customer's named facility not unloaded. Haworth will assume responsibility to file all freight claims with the carrier for any loss/damage which may occur while product is in transit, and will promptly repair or replace any damaged or lost product. Haworth requires the Customer to report all freight damage and/or loss to both the carrier and to Haworth.

NOTE: Under all delivery terms (U.S.A. and Canada), any additional expense resulting from Customer's request for expedited transportation, special services, packaging, handling, routing, and/or shipping method will be billed to Customer.

4. Mexico

All deliveries will be DAP (Delivered to Place) (ICC Incoterms 2010). Haworth's catalog prices include freight charges for normal surface transportation to a United States point of exportation within the 48 contiguous states. Haworth has the right to determine the carrier, method of shipment and routing.

Customer bears all risk of loss or damage to the goods when the goods are delivered to the named United States point of exportation. Haworth will provide customs clearance facilitation and arrangement of local delivery through an Authorized Dealer in Mexico, on a separately negotiated basis. Otherwise the Customer will be responsible for all customs clearance formalities and on-carriage from the United States point of exportation to the final destination in Mexico.

5. Delivery Dates and Delay

If Haworth cannot deliver products as scheduled due to causes beyond its reasonable control (such as casualty, labor disputes, or accident; inability to obtain necessary labor, material or transportation; or changes requested by the Customer), the delivery date will be extended to compensate for the delay as determined by Haworth.

6. Delivery Shortages and Damage

Product shortages and damage must be noted on delivery receipts at the time of delivery and reported to the carrier for correction.

Claims against Haworth for shortages, errors, or damage must be made within ten (10) days of the date of delivery or the Customer waives the right to make such a claim. Signed Bill of Ladings or Delivery Receipt must be sent in with claims. See the Haworth/Haworth Dealers Roles and Responsibilities document for further details.

7. Storage

Haworth may transfer product to storage at the Customer's risk and expense if the Customer is unable or unwilling to take delivery of product as originally scheduled. Upon such transfer to storage, the Customer assumes risk of loss. Haworth will invoice the Customer for storage fees and the Customer will make payments in accordance with Haworth's standard payment terms.

North American Terms of Sale

D. General Terms

1. Governing Law

For products purchased for delivery in the U.S. pursuant hereto, this Agreement shall be governed by and construed according to the laws of the State of Michigan. Where Products are purchased for delivery in Canada pursuant hereto, this Agreement shall be governed by and construed according to the laws of the Province of Alberta. In either case, the parties attorn to the exclusive jurisdiction of the courts of Michigan and Alberta, respectively for the purpose of hearing any disputes arising under this Agreement or with respect to any Products sold pursuant hereto, and agree that the provisions of the United Nations Convention on Contracts for the International Sale of Goods and any other provision or law which would have the effect of applying the laws of any jurisdiction other than Michigan or Alberta, as the case may be, shall be excluded.

2. Force Majeure

In the event that the performance of Customer or Haworth or its participating dealer assignee(s) would be prevented, restricted, interfered with or rendered commercially impracticable by reason of Force Majeure, then upon the giving of notice to the other parties, the party affected by the Force Majeure shall be excused from performing hereunder until the Force Majeure no longer prevents, restricts, interferes with, or renders such performance commercially impracticable.

"Force Majeure" shall mean: fire, explosion, breakdown of plant, epidemic, hailstorm, snow/ice storms en route, hurricane, tornado, cyclone, flood or power failure; war, revolution, civil or military disturbances, acts of public enemies, acts of terrorism, blockade or embargo; any law, order, proclamation, regulation, ordinance, demand or requirement of any applicable governmental authority or any subdivision, authority, or representative of any such government; labor difficulties, including without limitation, strikes, slowdowns, picketing or boycotts; or difficulties beyond Haworth's reasonable control in obtaining necessary raw materials, labor, fuels and electric power, components or facilities, and any other circumstances beyond the control of the party affected.

3. Delays by Customer

Where Haworth has not received adequate site dimensions, Product specifications, shipping information, installation particulars or other information required by Haworth to permit the efficient manufacture of any Products, or where site conditions are not in accordance with the Installation Requirements set forth, or are not otherwise suitable to permit effective and efficient installation, the manufacture and/or delivery of Products may be delayed, and such event shall constitute a delay by the Customer. When manufacture, delivery or installation is delayed by the Customer or at the Customer's request: (i) Haworth may, at its option, present the invoice for the full price of the Products to the Customer as then due and payable; (ii) the Customer shall pay to

Haworth all reasonable storage, handling and other reasonable incidental expenses incurred by Haworth in connection with such delay; and (iii) the Customer shall bear all risk of loss or damage to the Products being held by Haworth for the Customer.

4. Use and Installation of Products

Haworth recommends that its products be installed by certified, qualified and approved installers according to Haworth's written installation procedures. The Customer agrees to use Haworth products properly; not to remove or alter safety devices, warnings, or operation instructions placed on products by Haworth, and to instruct employees as to the proper care and use of the products according to printed instructions.

5. Warranty

Haworth's standard North American Warranty will apply as appropriate. All product line warranty specifics are available in each catalog or upon request.

E. Services

Service requests for design, installation, relocation, storage, etc. are handled by the local Haworth dealer on a separately negotiated basis. Contact the local Haworth dealer, affiliate or area sales office for more details.

Scope of Work - Design

Customer acknowledges that the Products to be manufactured or procured by Haworth in connection with the order are or may be custom manufactured for the Customer and that Haworth may be required to perform extensive work in relation to the design and specification of such Products. Where Customer requests that Haworth create as-built drawings or make more than two material revisions to any particular Product design or specification, Customer agrees that Haworth shall be entitled to invoice Customer with respect to such additional work on the basis of Haworth's then prevailing rates for related design and specification services.

Installation Requirements

Where installation services are to be provided by Haworth, its authorized dealer or subcontractor, a document will be provided setting forth the scope of installation work to be performed (the "Scope of Work") and the price to be charged therefore. Unless otherwise specified in the scope of work, Haworth's installation services are limited to products sold by Haworth with the exception of lighting, under floor electrical and data.

General Conditions

(a) Sufficient time shall be allocated by the Customer following delivery of Products and prior to Customer's occupation of the premises to allow the installation of all Products during conventional working hours, Monday through Friday, 7:30 a.m. to 4:30 p.m. Where sufficient time is not allocated and Haworth is required or requested to perform installation work outside of such times, overtime charges shall be charged at Haworth's then prevailing rates. (b) Haworth shall be given free and exclusive access to; (i) a loading dock within 150' of the freight elevator or hoist, which loading dock shall be of sufficient size to enable full-size tractor-trailer deliveries to the premises (where required by Haworth); (ii) a freight elevator or hoist of sufficient size and capacity to allow the efficient movement of the Products; (iii) an unobstructed and safe pathway to the area where Products are to be stored or staged; (iv) a secure storage / staging area; (v) convenient trash facilities; (vi) adequate lighting; (vii) a work site that complies with applicable health and safety legislation. Where such areas and facilities are not available, Haworth shall be entitled to bill Customer for all amounts incurred by Haworth for double-handling, product movement, lifting, hoisting, trash removal and any other resulting charges. (c) The installation site shall be free and clear of existing furniture, debris, or other obstructions (including construction in progress) and shall otherwise be in the reasonable opinion of Haworth ready for installation of the Products. Any building where Products are to be installed shall be fully closed in, dry and protected from the natural elements, with temperatures between 40°F and 90°F (4°C and 32°C) and relative humidity not to exceed 70% at all times including receipt of products, during and after installation and shall be adequately heated and/or air-conditioned. Where unusual site conditions exist which impede or prevent the normal installation of any Products, applicable extra charges shall apply at prevailing rates. (d) Haworth's installation pricing is based upon the installation occurring as one continuous delivery and installation project. Phased installation pricing shall be provided by Haworth on a case by case basis. (e) Electrical hardwiring, plumbing and mechanical work is not included and shall be the responsibility of the Customer. (f) Except as may be otherwise specifically indicated, installation pricing does not apply to projects where union labor is required. Where Haworth has provided installation pricing on the basis that non-union labor be utilized, and where Haworth is required to use union labor or it otherwise becomes impractical to use non-union labor, or where Haworth is required by law to use prevailing wages, Haworth shall be entitled to charge the Customer for any cost differential between the anticipated cost of non-union labor and the actual cost of utilizing union or prevailing wage labor. (g) Haworth shall not be responsible for obtaining permits.

North American Terms of Sale

Project / Site Conditions

Lateral load bracing is not included in the scope of Haworth's work and shall not be performed by Haworth. In areas where flooring Products are to be installed by Haworth overhead construction must be completed prior to the commencement of such work to avoid damage to the panels and finishes. The existing subfloor must be smooth, mopped clean, free of moisture, dust, dirt and debris. Once installed, the access floor must be maintained in the same manner. The subfloor must have a maximum vertical elevation deviation of 0.375" (10mm) over a horizontal span of 10'-0" (3m), and without discontinuities in floor slope. For greater certainty, the scope of Haworth's installation work in such areas shall not be deemed to include any work required to level such subfloor, remove protrusions, remove pre-existing floor coverings or adhesives, or any other work which is required to remedy any conditions which may impede the efficient installation of flooring. Except as may be otherwise specifically indicated in the order, installation pricing for flooring Products and the Scope of Work in relation thereto shall not include any work required to remove and replace floor panels following their initial installation to provide tradespersons or others with access to the underpanel cable management cavity. In areas where movable walls are to be installed, all flooring (including carpeting) and ceiling components (including dropped ceiling grid components) shall be fully complete and ready for the installation of the movable wall products. Further, the existing floor (or other surface on which the movable wall panels are to be installed) shall have a maximum vertical deviation of 1.25" (30mm) and the dropped ceiling grid shall have a maximum vertical deviation of 0.375" (10mm) from the specifications to which such movable wall panels were designed and manufactured (collectively the "Permitted Tolerances"), and shall otherwise comply with any site condition assumptions made known to Haworth prior to the manufacture of such Products (the "Site Assumptions"). Where the Permitted Tolerances or Site Assumptions are not strictly adhered to or met, additional charges may be incurred in connection with site remediation and/or the modification or remanufacture of affected movable wall products, together with all resulting shipping and labor charges at Haworth's then prevailing rates for such Products and services.

Installation Change Orders

Where Customer requests work to be performed or materials to be provided which are not contemplated in the Scope of Work, or Customer otherwise requests Products or services not contemplated in the order (collectively "Extras"), prior to providing such Extras Haworth reserves the right to require the Customer to provide and sign a written Purchase Order or Change Order acceptable to Haworth describing the Extras and the amounts to be charged therefore, and the Customer agrees to pay such charges.

Entire Agreement

The order and this Agreement (including applicable Schedules) constitute the sole agreement between the parties and supercede any prior understanding or written or oral agreements between the parties (excluding National Sales Agreements). No waiver of any of the provisions of these Standard Terms and Conditions shall be binding on Haworth unless expressly agreed in writing.

Revision Date: April 1, 2019

Index

Products are listed alphabetically in this index by alpha-numeric prefix/suffix codes.

Product Code	Product Description	Page
EAE1-A331	Planes Training Tables Quick Connect Power – Flip Top Unit Accessories	280
EAEB	Planes Training Tables 2-Circuit — Power Feeds – Hardwire Modular Base Feed — 2-Circuit	274
EAEB	Planes Training Tables Quick Connect Power — Flip Top Unit Accessories – Starter Box	278
EAEB-2024-2C	Planes Training Tables 2-Circuit — Power Feeds – Single Circuit Corded Base Feed — for use with 2-Circuit, 20 Amp	274
EAED-0000-22	Planes Training Tables 2-Circuit — Modular Power Components – Receptacle Block Connector	277
EAED-0000-24	Planes Training Tables 2-Circuit — Modular Power Components – Four-Port Splitter	277
EAEJ	Planes Training Tables 2-Circuit — Modular Power Pass-Through – Tables Pass-Through Connector — 2-Circuit	275
EAEJ-1	Planes Training Tables Quick Connect Power — Flip Top Unit Accessories – Table Pass-Through Connector	278
EAEM	Planes Training Tables 2-Circuit — Modular Power Kits — 2-Circuit	276
EAER	Planes Training Tables 2-Circuit — Modular Power Components – Receptacles — 15 Amp 2-Circuit	277
EAWP-0004-21	Planes Training Tables 2-Circuit — Power Feeds – Wall Feed — 2-Circuit	274
EHPO	Immerse — Planter — Oblong	110
EHPR	Immerse — Planter — Round	111
EUDB-0000	Cultivate Power Module Clips and Brackets – Mounting Bracket for Enhanced Power Modules	32
EUIM	Executive Wood Tables – A5 – Electric Lift Interface Module	73
EUMC-0201	Cultivate Power Module Clips and Brackets – Mounting Clip for Flip Top Unit	32
EUTP	Executive Wood Tables – A5 – Telecom Plates for Interface	73
EWCX-5001-V	Planes — Accessories – HDMI or VGA Cable	384
EWCX-BRWM	Planes — Electrical Accessories – Cable Base Cable Retractor	386
EWCX-H	Planes — Accessories – HDMI or VGA Cable	384
EWCX-V	Planes — Accessories – HDMI or VGA Cable	384
EWWM-0601	Cultivate Power Module Clips and Brackets – workware Interface Module Mounting Bracket for 2”(51mm) tops	32
GAC1	Planes Credenza Base – 29” High – Laminate or Wood	291
GAC1	Planes Credenza Bases – 19” High – Laminate or Wood	288
GAC2	Planes Credenza Base with Slider Unit — 35” High – Laminate or Wood	290
GAC2	Planes Credenza Base with Slider Unit — 39” High – Laminate or Wood	292
GAC2	Planes Credenza Base with Slider Unit — 45” High – Laminate or Wood	293
GAC2	Planes Credenza Base with Slider Unit — 29” High – Laminate or Wood	289
GACJ	Planes Credenza Tops – Laminate or Wood	294
GAKD-1919	Planes Cart – Podium – Laminate or Wood	287
GAKE-1919	Planes Carts — Medium Media – Laminate or Wood	285
GAKF-1919	Planes Carts — Small Media – Laminate or Wood	284
GAKG-1935	Planes Carts – Catering – Laminate	286
KUWH-0202	Cultivate Bag Hook	31
MTR1-20	Improv Series Occasional Tables – Round Table	115
NCCL	PREMISE Square/Round – Round — Laminate or Wood Top	398
NCCW	PREMISE Square/Round – Round — Laminate or Wood Top	398
NCOL	PREMISE Teardrop – Laminate Top	400
NCOL-C	PREMISE Teardrop – Laminate Top	400
NCRL	PREMISE Oval/Rectangular – Rectangular — Laminate or Wood Top	399
NCRW	PREMISE Oval/Rectangular – Rectangular — Laminate or Wood Top	399
NCSL	PREMISE Square/Round – Square — Laminate or Wood Top	398
NCSW	PREMISE Square/Round – Square — Laminate or Wood Top	398
NCTY-LFG	PREMISE Tri Tables — Transactional – Symmetric with Glides or Casters	397
NCTY-LFM	PREMISE Tri Tables — Transactional – Symmetric with Glides or Casters	397
NCTY-LVG	PREMISE Tri Tables — Transactional – Symmetric with Glides or Casters	397
NCTY-LVM	PREMISE Tri Tables — Transactional – Symmetric with Glides or Casters	397
NCVL	PREMISE Oval/Rectangular – Oval — Laminate or Wood Top	399
NCVW	PREMISE Oval/Rectangular – Oval — Laminate or Wood Top	399
STP-P26-TH	Pip – Personal Laptop Table	226
T7MB-1860-7	Hoop Table	77
TA01	Planes Credenza Tops – Grommet	294
TA01	Planes Conference Table — Column Base (for use with Conference Table Top) – J-Channel Tray	298

Product Code	Product Description	Page
TA01-0001	Planes Collaborative Tables — Accessories — Ganging Clip	239
TA01-0212	Planes Collaborative Tables — Accessories — Vertical Wire Management	239
TA01-0213	Planes Collaborative Tables — Accessories — Y-Leg Bumper	239
TA01-0214	Planes Collaborative Tables — Accessories — Y-Leg Bumper	239
TA01-0215	Planes Training Tables — Accessories — Glides	282
TA01-0215	Planes Collaborative Tables — Accessories — Glides	240
TA01-0216	Planes Training Tables — Accessories — Casters	282
TA01-0216	Planes Collaborative Tables — Accessories — Casters	240
TA01-0217	Planes — Accessories — Cable Column	383
TA01-0222	Planes Collaborative Tables — Accessories — Ganging Mechanism	239
TA01-0222	Planes Training Tables — Accessories — Ganging Mechanism	282
TA01-0224	Planes Training Tables 2-Circuit — Modular Power Components — Mounting Bracket — Receptacle	277
TA01-0225	Planes Training Tables — Accessories — Wire Manager Clips	283
TA01-0225	Planes Training Tables Quick Connect Power — Flip Top Unit Accessories — Wire Manager Clips	278
TA01-0227	Planes Training Tables Quick Connect Power — Flip Top Unit Accessories — Starter Box Bracket	278
TA01-0228	Planes Training Tables — Accessories — Vertical Wire Manager	283
TA01-0814	Planes — Accessories — Cable Base	383
TA01-1414	Planes — Accessories — Cable Base	383
TA01-CR48	Planes — Electrical Accessories — Cable Reel	385
TA01-CRBK	Planes — Electrical Accessories — Cable Reel Bracket	385
TA01-PB21	Planes — Electrical Accessories — Cable Management Processor Bracket	386
TA0M	Planes Training Tables — Modesty Panels	272
TABC	Cultivate Wire Management — Basket Cover	33
TABN-L	Planes Training Tables — Crescent — Laminate — Flip Top or Non-Flip Top Table	262
TABN-W	Planes Training Tables — Crescent — Wood — Flip Top or Non-Flip Top Table	268
TACB-2	Planes Conference Tables — Column Base (for use with Conference Table Top and End Supported Top) — Column Frame	295
TACB-4	Planes Conference Tables — Column Base (for use with Conference Table Top and End Supported Top) — Column Frame	295
TACB-7	Planes Conference Tables — Column Base (for use with Conference Table Top and End Supported Top) — Column Frame	295
TACC-F2	Planes Conference Table — Column Base (for use with Conference Table Top and End Supported Top) — Cladding — Flat and Round	297
TACC-R2	Planes Conference Table — Column Base (for use with Conference Table Top and End Supported Top) — Cladding — Flat and Round	297
TACV	Planes Collaborative Tables — Polygon — Laminate — Y-Leg Flip Top or Non-Flip Top Table	233
TACV	Planes Collaborative Tables — Polygon — Wood — Y-Leg Flip Top or Non-Flip Top Table	238
TACV	Planes Conference Tables — Interior Leg — Laminate — Polygon	303
TACV	Planes Conference Tables — Interior Leg — Wood — Polygon	307
TACV-L	Planes Training Tables — Polygon — Laminate — Flip Top or Non-Flip Top Table	264
TACV-W	Planes Training Tables — Polygon — Wood — Flip Top or Non-Flip Top Table	270
TAHN	Planes Collaborative Tables — Half Round — Laminate — Y-Leg Flip Top or Non-Flip Top Table	232
TAHN	Planes Collaborative Tables — Half Round — Wood — Y-Leg Flip Top or Non-Flip Top Table	237
TAHN	Planes Conference Tables — Interior Leg — Laminate — Half Round	302
TAHN	Planes Conference Tables — Interior Leg — Wood — Half Round	306
TAJC	Planes Conference Table — Column Base (for use with Conference Table Top) — J-Channels	298
TAPC-L	Planes Training Tables — Pie Connector — Laminate	265
TAPC-W	Planes Training Tables — Pie Connector — Wood	271
TAPL-R	Planes Conference Table — Column Base (for use with Conference Table Top and End Supported Top) — Column Base Plate — Square and Round	296
TAPL-S	Planes Conference Table — Column Base (for use with Conference Table Top and End Supported Top) — Column Base Plate — Square and Round	296
TARA	Planes Collaborative Tables — Rectangular — Laminate — Y-Leg Flip Top or Non-Flip Top Table	229
TARA	Planes Collaborative Tables — Rectangular — Wood — Y-Leg Flip Top or Non-Flip Top Table	234
TARA	Planes Conference Table Top — Rectangle (for use with Column Base) — Laminate or Wood	361
TARA	Planes Conference Tables — Interior Leg — Laminate — Rectangular	300
TARA	Planes Conference Tables — Interior Leg — Wood — Rectangular	304
TARA	Planes Conference Tables — One-Piece Top — Interior Leg — Laminate — Rectangular	308
TARA	Planes Conference Tables — One-Piece Top — Interior Leg — Wood — Rectangular	314

Index

Product Code	Product Description	Page
TARA	Planes Conference Tables — One-Piece Top — Perimeter Leg — Wood — Rectangular — 2”(51mm) Edge	351
TARA	Planes Conference Tables — Perimeter Leg — Laminate — Rectangular — 2”(51mm) Edge	344
TARA	Planes Conference Tables — Perimeter Leg — Wood — Rectangular — 2”(51mm) Edge	350
TARA	Planes Conference Tables — Three-Piece Tops — Interior Leg — Wood — Rectangular	338
TARA	Planes Conference Tables — Two-Piece Tops — Interior Leg — Wood — Rectangular	326
TARA	Planes Conference Tables — Two-Piece Tops — Perimeter Leg — Wood — Rectangular — 2”(51mm) Edge	352
TARA	Planes Conference Tables — Three-Piece Tops — Interior Leg — Laminate — Rectangular	332
TARA	Planes Conference Tables — Three-Piece Tops — Perimeter Leg — Laminate — Rectangular — 2”(51mm) Edge	348
TARA	Planes Conference Tables — Three-Piece Tops — Perimeter Leg — Wood — Rectangular — 2”(51mm) Edge	354
TARA	Planes Conference Tables — One-Piece Top — Perimeter Leg — Laminate — Rectangular — 2”(51mm) Edge	345
TARA	Planes Conference Tables — Two-Piece Tops — Interior Leg — Laminate — Rectangular	320
TARA	Planes Conference Tables — Two-Piece Tops — Perimeter Leg — Laminate — Rectangular — 2”(51mm) Edge	346
TARA-D	Planes Tables — Dual Disc Base — Laminate or Wood — Rectangle	252
TARA-L	Planes Training Tables — Rectangular — Laminate — Flip Top or Non-Flip Top Table	260
TARA-W	Planes Training Table — Rectangular — Wood — Flip Top or Non-Flip Top Table	266
TARA-XC	Planes Tables — Dual X Base — Laminate or Wood — Rectangle	246
TARA-XG	Planes Tables — Dual X Base — Laminate or Wood — Rectangle	246
TARD	Planes End Supported Top — D-Shape Convergent (for use with Column Base) — Laminate or Wood	376
TARN	Planes Conference Tables — Interior Leg — Laminate — Round	300
TARN	Planes Conference Tables — Interior Leg — Wood — Round	304
TARN	Planes Conference Table Top — Round (for use with Column Base) — Laminate or Wood	359
TARN-NDN	Planes Tables — Disc Base — Laminate or Wood	244
TARN-NXC	Planes Tables — X Base — Laminate or Wood	242
TARP	Planes Collaborative Tables — Pebble — Laminate — Y-Leg Flip Top or Non-Flip Top Table	230
TARP	Planes Collaborative Tables — Pebble — Wood — Y-Leg Flip Top or Non-Flip Top Table	235
TARP	Planes Conference Table Top — Pebble (for use with Column Base) — Laminate or Wood	365
TARP	Planes Conference Tables — One-Piece Top — Interior Leg — Laminate — Pebble	310
TARP	Planes Conference Tables — One-Piece Top — Interior Leg — Wood — Pebble	316
TARP	Planes Conference Tables — Three-Piece Tops — Interior Leg — Wood — Pebble	340
TARP	Planes Conference Tables — Two-Piece Tops — Interior Leg — Wood — Pebble	328
TARP	Planes Conference Tables — Three-Piece Tops — Interior Leg — Laminate — Pebble	334
TARP	Planes Conference Table Top — Pebble (for use with Column Base) — Laminate or Wood	359
TARP	Planes Conference Tables — Two-Piece Tops — Interior Leg — Laminate — Pebble	322
TARP-D	Planes Tables — Dual Disc Base — Laminate or Wood — Pebble	256
TARP-NDN	Planes Tables — Disc Base — Laminate or Wood	244
TARP-NXG	Planes Tables — X Base — Laminate or Wood	242
TARP-XC	Planes Tables — Dual X Base — Laminate or Wood — Pebble	250
TARP-XG	Planes Tables — Dual X Base — Laminate or Wood — Pebble	250
TARQ	Planes Conference Tables — Interior Leg — Laminate — Square	300
TARQ	Planes Conference Tables — Interior Leg — Wood — Square	304
TARQ	Planes Conference Tables — Perimeter Leg — Laminate — Square — 2”(51mm) Edge	344
TARQ	Planes Conference Tables — Perimeter Leg — Wood — Square — 2”(51mm) Edge	350
TARQ	Planes Conference Table Top — Square (for use with Column Base) — Laminate or Wood	359
TARQ-NDN	Planes Tables — Disc Base — Laminate or Wood	244
TARQ-NXC	Planes Tables — X Base — Laminate or Wood	242
TARU	Planes End Supported Top — Rectangular Conference End (for use with Column Base) — Laminate or Wood	378
TARX	Planes Collaborative Tables — Hexagon — Laminate — Y-Leg Flip Top or Non-Flip Top Table	231
TARX	Planes Collaborative Tables — Hexagon — Wood — Y-Leg Flip Top or Non-Flip Top Table	236
TARX	Planes Conference Table Top — Hexagon (for use with Column Base) — Laminate or Wood	369
TARX	Planes Conference Tables — One-Piece Top — Interior Leg — Laminate — Hexagon	312
TARX	Planes Conference Tables — One-Piece Top — Interior Leg — Wood — Hexagon	318
TARX	Planes Conference Tables — Three-Piece Tops — Interior Leg — Wood — Hexagon	342
TARX	Planes Conference Tables — Two-Piece Tops — Interior Leg — Wood — Hexagon	330
TARX	Planes Conference Tables — Three-Piece Tops — Interior Leg — Laminate — Hexagon	336
TARX	Planes Conference Tables — Two-Piece Tops — Interior Leg — Laminate — Hexagon	324

Product Code	Product Description	Page
TARX-D	Planes Tables — Dual Disc Base – Laminate or Wood – Hexagon	254
TARX-XC	Planes Tables — Dual X Base – Laminate or Wood – Hexagon	248
TARX-XG	Planes Tables — Dual X Base – Laminate or Wood – Hexagon	248
TARY	Planes End Supported Top — Key Conference (for use with Column Base) – Laminate or Wood	380
TATP-L	Planes Training Tables — Trapezoid — Laminate – Flip Top or Non-Flip Top Table	263
TATP-W	Planes Training Table — Trapezoid — Wood – Flip Top or Non-Flip Top Table	269
TAWB	Cultivate Wire Management – Wire Management Basket	33
TCBN	Jive Table — Post Extruded Base – Crescent – Laminate or Wood	135
TCBN-SNV	Jive Table — Post Round Base – Crescent – Laminate or Wood	153
TCHP	Jive Table — Post Extruded Base – Pebble Half – Laminate or Wood	137
TCHP	Jive Table — Post Round Base – Pebble Half – Laminate or Wood	155
TCHP-SNG	Jive Table — Bridge Base – Pebble Half – Laminate or Wood	180
TCHT	Jive Table — Post Extruded Base – Half Racetrack – Laminate or Wood	136
TCHT	Jive Table — Post Round Base – Half Racetrack – Laminate or Wood	154
TCHT-SNG	Jive Table — Bridge Base – Half Racetrack – Laminate or Wood	178
TCHX-SNG	Jive Table — Bridge Base – Half Hexagon – Laminate or Wood	182
TCRA	Jive Table — Post Extruded Base – Rectangle – Laminate or Wood	129
TCRA-LJSNR	Jive Table — Swivel Base – Rectangle – Laminate or Wood	214
TCRA-SNB	Jive Table — C-Leg — Round – Rectangle – Laminate or Wood	187
TCRA-SNC	Jive Table — C-Leg — Extruded – Rectangle – Laminate or Wood	183
TCRA-SND	Jive Table — Disc Base – Rectangle – Laminate or Wood	195
TCRA-SND	Jive Table — Dual Disc Base – Rectangle – Laminate or Wood	197
TCRA-SNF	Jive Table — T-Leg — Round – Rectangle – Laminate or Wood	205
TCRA-SNFH4	Jive Table — T-Leg (Round or Extruded) — Flip Base – Rectangle – Laminate or Wood	211
TCRA-SNG	Jive Table — Bridge Base – Rectangle – Laminate or Wood	171
TCRA-SNH	Jive Table — C-Leg (Round or Extruded) — Flip Base – Rectangle – Laminate or Wood	190
TCRA-SNT	Jive Table — T-Leg — Extruded – Rectangle – Laminate or Wood	199
TCRA-SNV	Jive Table — Post Round Base – Rectangle – Laminate or Wood	147
TCRA-SNX_	Jive Table — X-Base – Rectangle – Laminate or Wood	162
TCRA-SNXF	Jive Table — X-Base – Rectangle – Laminate or Wood	162
TCRN	Jive Table — Post Extruded Base – Round – Laminate or Wood	120
TCRN-SND	Jive Table — Disc Base – Round – Laminate or Wood	192
TCRN-SNG	Jive Table — Bridge Base – Round – Laminate or Wood	164
TCRN-SNV	Jive Table — Post Round Base – Round – Laminate or Wood	138
TCRN-SNX_	Jive Table — X-Base – Round – Laminate or Wood	156
TCRN-SNXF	Jive Table — X-Base – Round – Laminate or Wood	156
TCRP-3048-SNG	Jive Table — Bridge Base – Pebble – Laminate or Wood	166
TCRP-3060	Jive Table — Post Extruded Base – Pebble – Laminate or Wood	125
TCRP-3060-SNV	Jive Table — Post Round Base – Pebble – Laminate or Wood	143
TCRP-4242	Jive Table — Post Extruded Base – Pebble – Laminate or Wood	125
TCRP-4242-SNV	Jive Table — Post Round Base – Pebble – Laminate or Wood	143
TCRP-5454-SNG	Jive Table — Bridge Base – Pebble – Laminate or Wood	166
TCRP-SND	Jive Table — Disc Base – Pebble – Laminate or Wood	194
TCRP-SND	Jive Table — Dual Disc Base – Pebble – Laminate or Wood	196
TCRP-SNF	Jive Table — T-Leg — Round – Pebble – Laminate or Wood	208
TCRP-SNT	Jive Table — T-Leg — Extruded – Pebble – Laminate or Wood	202
TCRP-SNX_	Jive Table — X-Base – Pebble – Laminate or Wood	160
TCRP-SNXF	Jive Table — X-Base – Pebble – Laminate or Wood	160
TCRQ	Jive Table — Post Extruded Base – Square – Laminate or Wood	122
TCRQ-SND	Jive Table — Disc Base – Square – Laminate or Wood	193
TCRQ-SNG	Jive Table — Bridge Base – Square – Laminate or Wood	165
TCRQ-SNV	Jive Table — Post Round Base – Square – Laminate or Wood	140
TCRQ-SNX_	Jive Table — X-Base – Square – Laminate or Wood	158
TCRQ-SNXF	Jive Table — X-Base – Square – Laminate or Wood	158
TCRT	Jive Table — Post Extruded Base – Racetrack – Laminate or Wood	132

Index

Product Code	Product Description	Page
TCRT-SND	Jive Table — Dual Disc Base – Racetrack – Laminate or Wood	198
TCRT-SNE	Jive Table — T-Leg — Round – Racetrack – Laminate or Wood	209
TCRT-SNG	Jive Table — Bridge Base – Racetrack – Laminate or Wood	175
TCRT-SNT	Jive Table — T-Leg — Extruded – Racetrack – Laminate or Wood	203
TCRT-SNV	Jive Table — Post Round Base – Racetrack – Laminate or Wood	150
TCTP	Jive Table — Post Extruded Base – Trapezoid – Laminate or Wood	134
TCTP-SNF	Jive Table — T-Leg — Round – Trapezoid – Laminate or Wood	210
TCTP-SNT	Jive Table — T-Leg — Extruded – Trapezoid – Laminate or Wood	204
TCTP-SNV	Jive Table — Post Round Base – Trapezoid – Laminate or Wood	152
TEA5	Executive Wood Tables – A5 – Base Kit	71
TEBO	Executive Wood Tables – Boat (one piece)	57
TEBO	Executive Wood Tables – Boat (two piece)	57
TEBO	Executive Wood Tables – A5 – Boat Table Top	69
TECB	Executive Conference Buffet – Conference Buffet — Wood	37
TEFC	Executive Wood Tables – Base Kits — Boat Wood Tables	60
TEFC	Executive Wood Tables – Base Kits — Racetrack Wood Tables	56
TEFC	Executive Wood Tables – Base Kits — Rectangular Wood Tables	52
TEFC	Executive Wood Tables – Base Kits — Round/Square Wood Tables	48
TEFC	Executive Wood Tables – Base Kits — Wedge Wood Tables	64
TEFC-A	Executive Wood Tables – Base Kits — Boat Wood Tables	60
TEFC-A	Executive Wood Tables – Base Kits — Racetrack Wood Tables	56
TEFC-A	Executive Wood Tables – Base Kits — Rectangular Wood Tables	52
TEFC-A	Executive Wood Tables – Base Kits — Round/Square Wood Tables	48
TEFC-A	Executive Wood Tables – Base Kits — Wedge Wood Tables	64
TEGL	Executive Wood Tables – A5 – Glass Centerpiece	72
TEHC	Executive Wood Tables – Base Kits — Boat Wood Tables	60
TEHC	Executive Wood Tables – Base Kits — Racetrack Wood Tables	56
TEHC	Executive Wood Tables – Base Kits — Rectangular Wood Tables	52
TEHC	Executive Wood Tables – Base Kits — Wedge Wood Tables	64
TEHC-A	Executive Wood Tables – Base Kits — Boat Wood Tables	60
TEHC-A	Executive Wood Tables – Base Kits — Racetrack Wood Tables	56
TEHC-A	Executive Wood Tables – Base Kits — Rectangular Wood Tables	52
TEHC-A	Executive Wood Tables – Base Kits — Wedge Wood Tables	64
TEPB	Executive Accessories – Presentation Board	74
TERA	Executive Wood Tables – Rectangular (one piece)	49
TERA	Executive Wood Tables – Rectangular (two piece)	49
TERA	Executive Wood Tables – A5 – Rectangular Table Top	68
TERN	Executive Wood Tables – Round	47
TERQ	Executive Wood Tables – Square	47
TERT	Executive Wood Tables – Racetrack Tables (one piece)	53
TERT	Executive Wood Tables – Racetrack Tables (two piece)	53
TESL	Executive Wood Tables – Base Kits — Boat Wood Tables	60
TESL	Executive Wood Tables – Base Kits — Racetrack Wood Tables	56
TESL	Executive Wood Tables – Base Kits — Rectangular Wood Tables	52
TESL	Executive Wood Tables – Base Kits — Wedge Wood Tables	64
TEWE	Executive Wood Tables – Wedge (one piece)	61
TEWE	Executive Wood Tables – Wedge (two piece)	61
TEWE	Executive Wood Tables – A5 – Wedge Table Top	70
TEXB-M	Executive Wood Tables – Base Kits — Round/Square Wood Tables	48
TEXB-W	Executive Wood Tables – Base Kits — Boat Wood Tables	60
TEXB-W	Executive Wood Tables – Base Kits — Racetrack Wood Tables	56
TEXB-W	Executive Wood Tables – Base Kits — Rectangular Wood Tables	52
TEXB-W	Executive Wood Tables – Base Kits — Round/Square Wood Tables	48
TEXB-W	Executive Wood Tables – Base Kits — Wedge Wood Tables	64
THLD	Immerse — Ledge Table – Rectangle – Painted Legs	81

Product Code	Product Description	Page
THLD	Immerse — Ledge Table – Rectangle – Wood Legs	.82
THRA	Immerse — Single Table – Rectangle – Painted Legs	.103
THRA	Immerse — Single Table – Rectangle – Wood Legs	.107
THRA	Immerse — Stack Table – Rectangle – Painted Legs	.109
THRD	Immerse — Overlap Table – Rectangle/Round – Painted Legs	.86
THRD	Immerse — Overlap Table – Rectangle/Round – Wood Legs	.92
THRD	Immerse — Shift Table – Rectangle/Round – Painted Legs	.96
THRD	Immerse — Shift Table – Rectangle/Round – Wood Legs	.99
THRL	Immerse — Overlap Table – Rectangle/Ledge – Painted Legs	.88
THRL	Immerse — Overlap Table – Rectangle/Ledge – Wood Legs	.94
THRN	Immerse — Single Table – Round – Painted Legs	.101
THRN	Immerse — Single Table – Round – Wood Legs	.105
THRQ	Immerse — Single Table – Square – Painted Legs	.102
THRQ	Immerse — Single Table – Square – Wood Legs	.106
THRR	Immerse — Overlap Table – Rectangle/Rectangle – Painted Legs	.84
THRR	Immerse — Overlap Table – Rectangle/Rectangle – Wood Legs	.90
THRR	Immerse — Shift Table – Rectangle/Rectangle – Painted Legs	.95
THRR	Immerse — Shift Table – Rectangle/Rectangle – Wood Legs	.98
THRT	Immerse — Single Table – Racetrack – Painted Legs	.104
THRT	Immerse — Single Table – Racetrack – Wood Legs	.108
THTD	Immerse — Overlap Table – Racetrack/Round – Painted Legs	.87
THTD	Immerse — Overlap Table – Racetrack/Round – Wood Legs	.93
THTD	Immerse — Shift Table – Racetrack/Round – Painted Legs	.97
THTD	Immerse — Shift Table – Racetrack/Round – Wood Legs	.100
TKRA	Reside Tables — Laminate/Wood – Rectangular	.406
TKRN	Reside Tables — Laminate/Wood – Round	.404
TKRP	Reside Tables — Laminate/Wood – Pebble	.404
TKRQ	Reside Tables — Laminate/Wood – Square	.403
TKRX	Reside Tables — Laminate/Wood – Hex	.405
TPAP	PopUp Table – Accent Plate	.393
TPRA-SNA	PopUp Table – Rectangle – Laminate or Wood	.390
TPRP-SNA	PopUp Table – Oval (Rectangular Radius Corner) – Laminate or Wood	.391
TPRT-SNA	PopUp Table – Racetrack – Laminate or Wood	.392
TPVW	PopUp Table – Vertical Wire Channel – Leg Attached	.394
TVBN-LJSNR	Jive Table — Swivel Base – Crescent – Laminate or Wood	.216
TVCE-LJSNRE	Jive Table — Swivel Base – Corner, Extended – Laminate or Wood	.218
TVCX-LJSNRP	Jive Table — Swivel Base – Corner, Transitional Extended – Laminate or Wood	.217
TVRQ-LJSNR	Jive Table — Swivel Base – Square – Laminate or Wood	.213
TVTP-LJSNR	Jive Table — Swivel Base – Trapezoid – Laminate or Wood	.215
TYBA-NNNNNG4A	Cultivate Frames	.30
TYBA-NNNNNG7A	Cultivate Frames	.30
TYRA-LJMN	Cultivate Tops – No Storage	.28
TYRA-LJMN	Cultivate Tops – For use with Storage	.29
TYRA-LJSN	Cultivate Tops – No Storage	.28
TYRA-LJSN	Cultivate Tops – For use with Storage	.29
TYRA-WKMN	Cultivate Tops – No Storage	.28
TYRA-WKMN	Cultivate Tops – For use with Storage	.29
TYRA-WKSN	Cultivate Tops – No Storage	.28
TYRA-WKSN	Cultivate Tops – For use with Storage	.29
TYVW	Cultivate Wire Management – Vertical Wire Channel - Leg Attached	.33
TZRN-L	Compose Tables — Laminate – Round — Disc Base	.21
TZRN-LG	Compose Tables — Laminate – Round — Post Base	.21
TZRN-W	Compose Tables — Wood – Round — Disc Base	.22
TZRN-WG	Compose Tables — Wood – Round — Post Base	.22
UXCD-N	Executive Conference Buffet – Center Drawer	.37

Index

<u>Product Code</u>	<u>Product Description</u>	<u>Page</u>
WQAG-PS	Planes Training Tables — Accessories – Grommet283
XLAS-3030	Master Series Table — Square221
XZAM-1S	Master Series Table — Round221
XZAS-3030	Master Series Table — Square221
ZUBW-0000-PN	Planes End Supported Top (for use with Column Base) — Wall Mount Bracket(s)382
ZZBA-0000-PL	Planes End Supported Top (for use with Column Base) — Side/Corner Bracket382
ZZBA-0000-PLF	Planes End Supported Top (for use with Column Base) — Side Bracket for use with Knife Edge382
ZZBA-0000-PR	Planes End Supported Top (for use with Column Base) — Side/Corner Bracket382
ZZBA-0000-PRF	Planes End Supported Top (for use with Column Base) — Side Bracket for use with Knife Edge382

Great Expectations

You have them as a Haworth customer and so do we. And because we value our customers, we cover our products with the Haworth North America Product Compatibility and Limited Warranty Policy.

Product Compatibility and Limited Warranty Policy

Our Commitment To Product Compatibility – Integrated Product Platforms

As a market leader in the design and manufacture of workspaces that adapt to change, we strive to maintain product compatibility within our various generations of integrated product platforms. This benefits the customer who desires to update or modify their work environment. It also benefits the customer needing to replace a product due to damage or other reasons but which is no longer manufactured or is otherwise unavailable, such as a fabric or finish that is discontinued because of changing market preferences. In both circumstances, we often can provide products with comparable function and performance.

Our Commitment To Product Quality – The Haworth North America Limited Warranty

To ensure customer satisfaction and peace of mind, we stand behind our products with the Haworth North America Limited Warranty. To review the current version of the limited warranty including its terms and conditions, please go to:

www.haworth.com/resources/product-info/warranties or contact Haworth's First Call Center at **800.426.8562**.

Warranty Requests or Questions

For questions or service requests pertaining to the Haworth Limited Warranty, please contact your Haworth dealer.

If you are unsure who your dealer is, please call Haworth's First Call Center at **800.426.8562**.

Effective: January 1, 2020

HAWORTH®

HAWORTH® is a registered trademark of Haworth, Inc.
© Haworth, Inc. All rights reserved. 2020 2.20 | Item #1070
haworth.com | 800 344 2600