

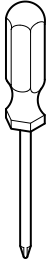

Tools Required:

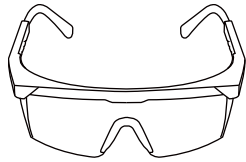

Flat Screw Driver



Safety Glasses

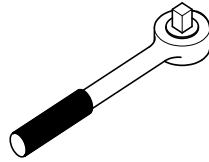

Ratchet Wrench

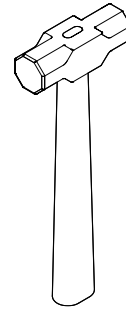

Sledge Hammer

Materials Identification and Segregation:

Where possible, plastic components are marked with ASTM recycling codes. Use these codes to identify material type for recycling. Non marked components should be treated as mixed plastic. Ferrous metals can be identified using a small magnet for recycling. Non-ferrous metals should be separated and recycled separately.

Steps:



1. Pull drawer out. Remove from drawer slides.

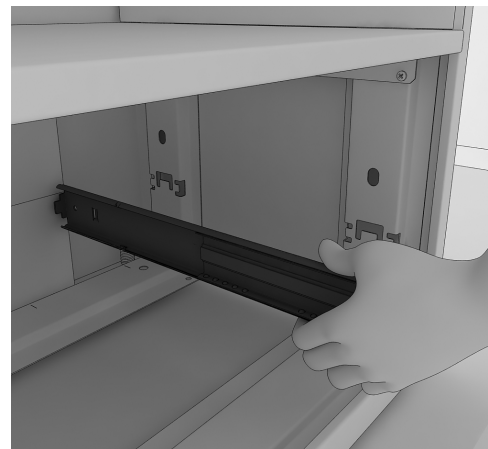

2. Disengage slide and remove.

3. Repeat step 2 to remove rest of slides.



4. Using phillips head screw driver remove all screws from shelf.

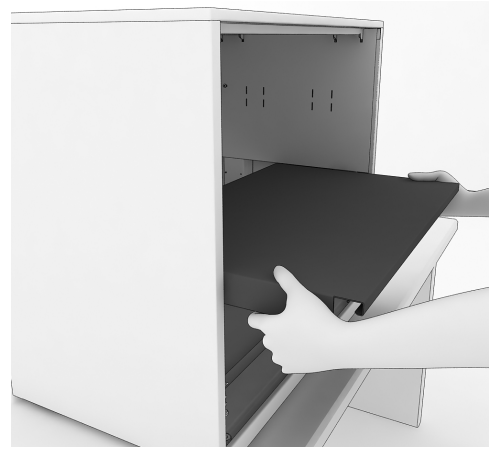

5. Remove shelf from assembly.

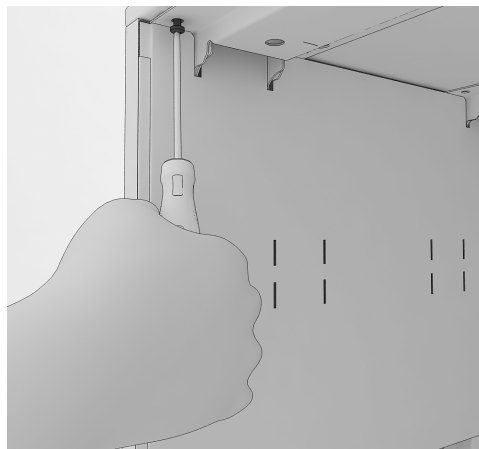

6. Using phillips head screw driver remove screws from Spreader.

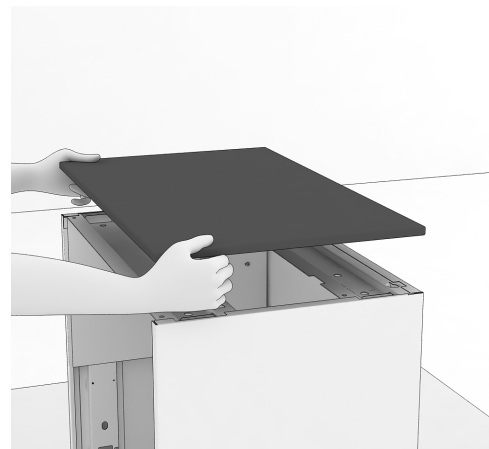

7. Remove top surface from assembly.

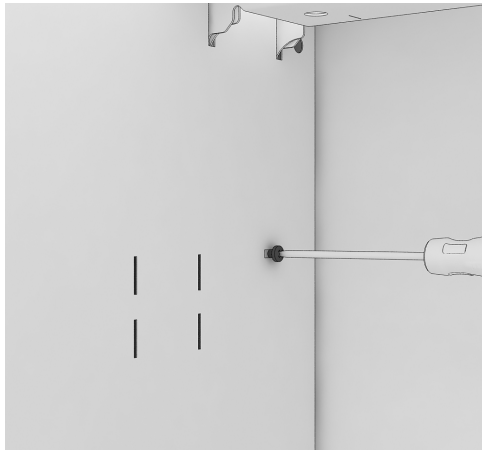

8. Using phillips head screw driver remove screws from inner panel.

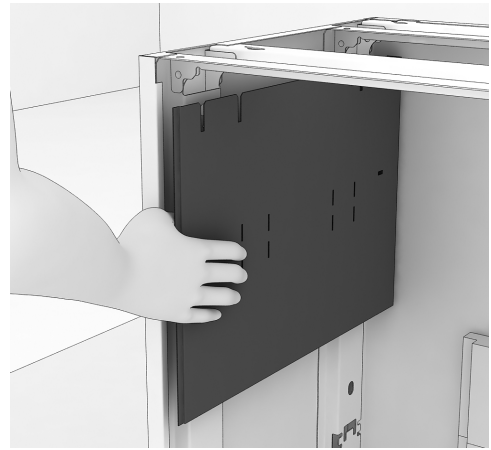

9. Slide down and remove inner panel from assembly.

10. Repeat step 8 and 9 to remove other side inner panel.

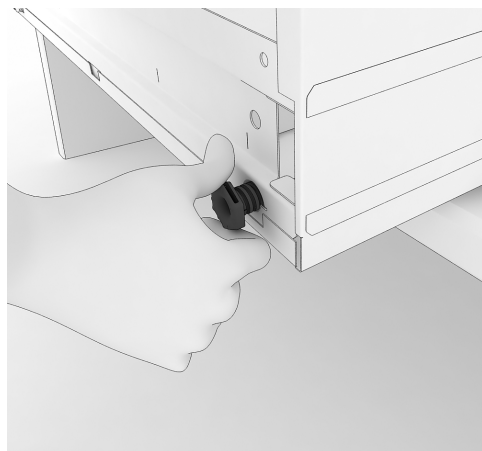

11. Remove leveler.

12. Repeat step 11 to remove other 3 levelers.

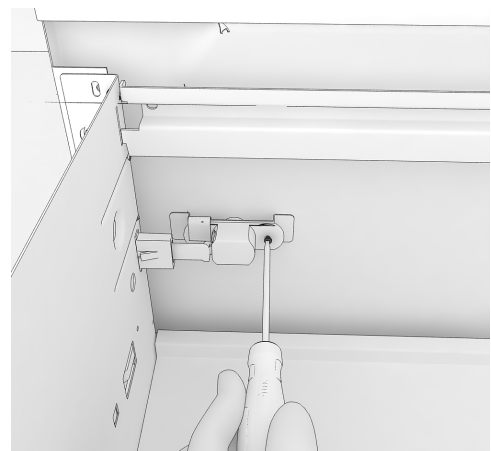

13. Using phillips head screw driver remove screws from lock assembly.

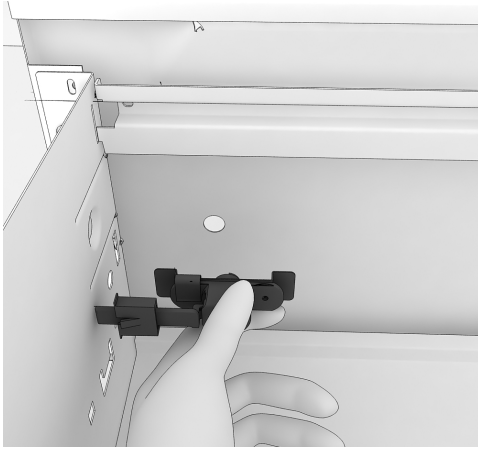

14. Remove lock from assembly.

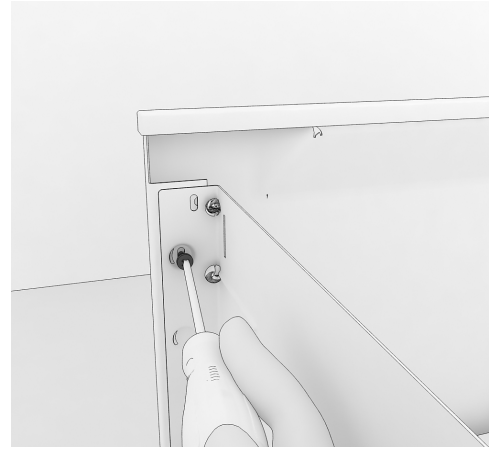

15. Using phillips head screw driver remove screws from end panel.

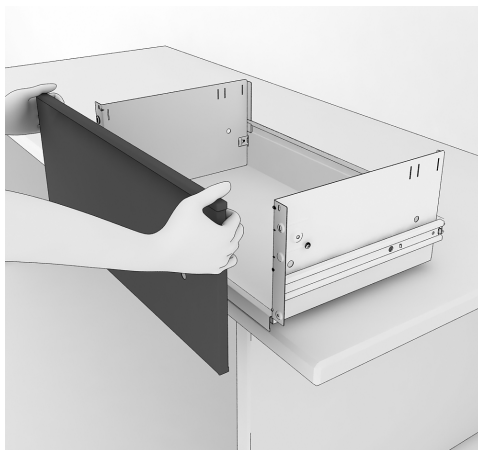

16. Remove drawer front.

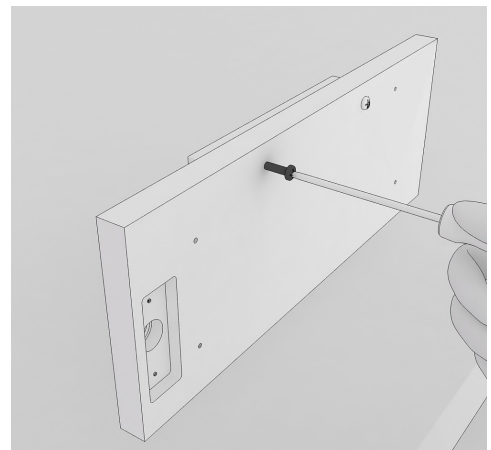

17. Using phillips head screw driver remove screws from drawer front.

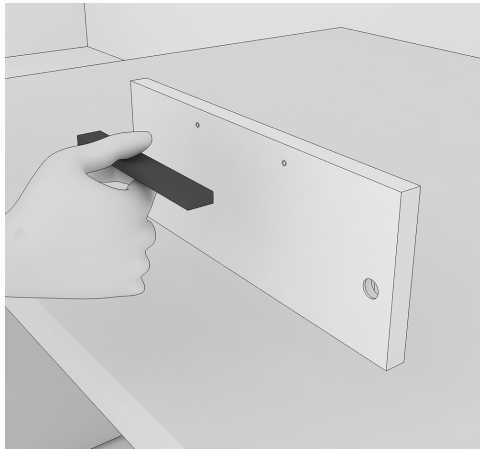

18. Remove handle from drawer front.

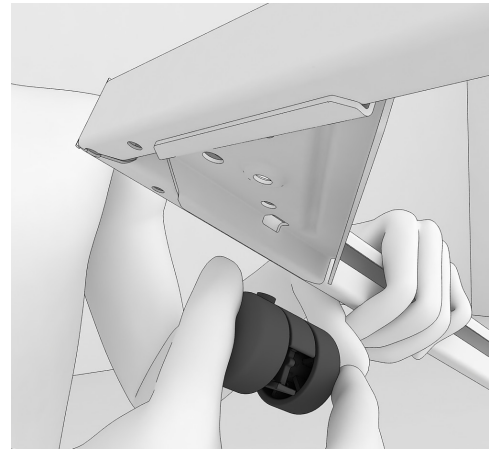

19. Pull caster from base and remove.

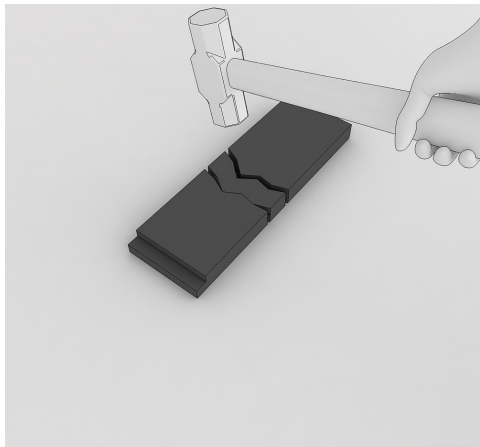

20. Using Sledge hammer hit on the concrete counter weights and break into pieces.

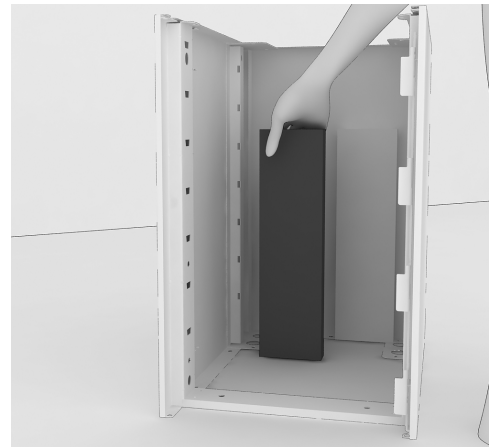

21. Remove Steel counter weights from assembly.