



GSA prices effective April 1, 2019
(based on January 7, 2019, commercial price list)
Published April 2019

Storage Systems

Tu® Metal Storage

**General Services Administration
Federal Supply Service
Authorized Federal Supply Schedule Price List**

Online access to contract ordering information, terms and conditions, up-to-date pricing, and the option to create an electronic delivery order is available through GSA Advantage!®, a menu-driven database system. The Internet address for GSA Advantage! is www.gsaadvantage.gov.

Office Furniture
FSC Group 71, Part 1
Contract Number: GS-03F-036DA
Contract Period: December 21, 2015—December 20, 2020

Herman Miller, Inc.
855 East Main Avenue
Zeeland, Michigan 49464
(616) 654 3000 Phone
(616) 654 8278 Fax
www.HermanMiller.com/government

Business Size: Large

Contract Information

1a. Special Item Numbers (SIN)

SIN 71-1
Packaged Offices

SIN 711-1
Furniture Systems

SIN 711-2
Computer Furniture

SIN 711-3
Filing and Storage Cabinets

SIN 711-11
Tables and Accessories

SIN 711-16
Upholstered Seating

SIN 711-18
Multi-Purpose Seating

SIN 711-91
Project Management

Services under this SIN may be used only in conjunction with the purchase of new furniture. Please contact your local Herman Miller representative to discuss the available labor categories (listed below). The hourly rates listed are "Not To Exceed" or "NTE" values.

Furniture Project Manager: \$64.75 per hour
Furniture Project Coordinator: \$49.00 per hour
Build-Out Project Manager: \$80.00 per hour

SIN 711-93
Reconfiguration and Relocation Services

Reconfiguration and Relocation Services will be provided by Herman Miller, Inc., or its participating dealer based on a fee not to exceed \$55 per hour, which applies to services totaling \$150,000 (per SIN) and below only. Services above \$150,000 shall be negotiated on a case-by-case basis. This SIN may only be used with the purchase of new product under SIN 711-1.

See * Additional Notes for Installation & Reconfiguration and Relocation Services.

SIN 711-94
Design/Layout

Design service will be provided by Herman Miller, Inc., or its participating dealer based on a fee not to exceed \$65 per hour.

SIN 711-95

Installation Services

Installation Services will be provided by Herman Miller, Inc., or its participating dealer based on a fee not to exceed \$55 per hour (\$82.50 per hour for after-hours Installation), which applies to services totaling \$150,000 (per SIN) and below only. Services above \$150,000 shall be negotiated on a case-by-case basis.

See * Additional Notes for Installation & Reconfiguration and Relocation Services.

* Additional Notes for Installation & Reconfiguration and Relocation Services:

FOB Destination (Drop Ship): Price includes product delivery to the site, brought to the tailgate of the truck. The purchaser is responsible for unloading.

Prices effective up to the maximum order by SIN only. Above the MO, pricing shall be negotiated on a case-by-case basis between the client and local dealer.

Standard Services are Subject to the Following Conditions:

Installation will be performed during normal weekday working hours.

Adequate facilities for delivery, unloading, moving and staging/ storing the product during the installation process shall be provided.

Service work will not be hindered by other trades.

Electric, heat, and adequate elevator service will be furnished without charge.

The immediate installation area shall be complete and free of debris including the carpet/flooring before installation commences.

Any work requiring a licensed electrician is the responsibility of the buyer.

Additional Charges May Apply For:

Major Metro Markets and any non-ground floor installation.

Major Metro Markets include large population centers and urban environments.

Installation in a clinical/medical environment.

Special restrictions or limits established by local laws, ordinances or the directions of the buyer, including but not limited to restrictions on transportations of materials, street access to the job site and/or dock facilities.

Installations outside of a 50 mile radius of the servicing dealer.

Local Prevailing Wage and/or Union Labor Rates.

Any additional charges shall be quoted by the dealer and approved by the buyer prior to performance of the work.

SIN 711-96

Leasing

Contact Herman Miller participating government dealer for current leasing information.

SIN 711-99

New Product Introductions

Contract Information

continued

SIN 711-500

Order-Level Materials (OLMs)

This SIN is only for products and/or services used in direct support of the purchase of new furniture. It requires approval from the ordering Contract Officer. Please contact your local Herman Miller representative to discuss the appropriate use of this SIN.

1b. Lowest Priced Model

SIN 711-1:	G9999.B	\$9
SIN 711-2:	6-5-D	\$40
SIN 711-3:	L29P.15	\$11
SIN 711-11:	DT9A.	\$39
SIN 711-16:	OA401	\$43
SIN 711-18:	AS90598	\$51
SIN 711-99:	BVP3.S	\$12

1c. Not applicable

2. Maximum Order

SIN 711-1, SIN 711-2
\$500,000 net product value

SIN 711-3, SIN 711-11
\$300,000 net product value

SIN 711-16, SIN 711-18
\$200,000 net product value

SIN 711-93
\$150,000

SIN 711-94
\$150,000

SIN 711-95
\$150,000

SIN 711-96
\$500,000 net product value

SIN 711-99
\$50,000 net product value

SIN 711-500
\$100,000

3. Minimum Order

\$100 net

4. Geographic Coverage

Continental U.S.

Orders for Alaska, Hawaii, and Puerto Rico will be shipped F.O.B. inland carrier point of exportation.

5. Point of Production

Zeeland, Ottawa County, Michigan
Spring Lake, Ottawa County, Michigan

6. Pricing

Prices shown are list. Discounts include Industrial Funding Fee.

SIN 711-1

Product: Selected Action Office 1, Action Office 2, C-Style Overhead Storage, Ethospace System, Quadrant Pedestals, Supplemental Products, Tu Pedestals, and approved Herman Miller Options Products.

Standard Lead Time	Single Order Net Purchase	Discount From list
	\$100 - 250,000	73.8%
	\$250,001 - 500,000	76.8%

SIN 711-1

Product: Selected Nevi™ Tables, Renew™ Tables, Renew Link and approved Herman Miller Options Products

Standard Lead Time	Single Order Net Purchase	Discount From List
	\$100 - 500,000	73.8%

SIN 711-1

Product: Selected Motia™ Tables, and approved Herman Miller Options Products

Standard Lead Time	Single Order Net Purchase	Discount From List
	\$100 - 500,000	73.8%

SIN 711-1

Product: Tu Wood Pedestals and approved Herman Miller Options Products

Standard Lead Time	Single Order Net Purchase	Discount From List
	\$100 - 300,000	74.3%

SIN 711-1

Product: Selected Canvas Office Landscape (Beam, Dock, Group, Metal Storage, Private Office, Vista, Wall, and Wood Storage) and approved Herman Miller Options Products

Standard Lead Time	Single Order Net Purchase	Discount From List
	\$100 - 500,000	74.8%

Contract Information

continued

SIN 711-1

Product: Selected Layout Studio® and approved Herman Miller Options Products

Standard Lead Time	Single Order Net Purchase	Discount From List
	\$100 - 500,000	60.7%

SIN 711-1

Product: Selected Meridian Pedestals and approved Herman Miller Options Products

Standard Lead Time	Single Order Net Purchase	Discount From List
	\$100 - 500,000	64.2%

SIN 711-1

Product: Selected Thrive Portfolio and approved Herman Miller Options Products

Standard Lead Time	Single Order Net Purchase	Discount From List
	\$100 - 250,000	62%
	\$250,001 - 500,000	66.4%

SIN 711-2

Product: Approved Herman Miller Options Products

Standard Lead Time	Single Order Net Purchase	Discount From List
	\$100 - 500,000	58.7%

SIN 711-3

Product: Meridian Laterals, Towers, and Storage products and approved Herman Miller Options Products

Standard Lead Time	Single Order Net Purchase	Discount From List	Towers & Storage
	\$100 - 300,000	67.3%	62.7%
		66.3%	

SIN 711-3

Product: Tu Lateral Files, Tu Storage, Tu Towers, Tu Wood Cases, Tu Wood Cubbies, Tu Wood Credenzas, Tu Wood Towers, and approved Herman Miller Options Products

Standard Lead Time	Single Order Net Purchase	Discount From List
	\$100 - 300,000	74.3%

SIN 711-11

Product: Selected Tables and Accessories and approved Herman Miller Options Products

Standard Lead Time	Single Order Net Purchase	Discount From List
Avive® Tables	\$100 - 250,000	72.8%
	\$250,001 - 500,000	74.8%
Herman Miller Eames® Tables	\$100 - 250,000	73.6%
	\$250,001 - 300,000	77.6%
Everywhere™ Tables	\$100 - 300,000	72.8%

SIN 711-16

Product: Swoop upholstered seating products and approved Herman Miller Options Products

Standard Lead Time	Single Order Net Purchase	Discount From List
Plex Lounge Furniture	\$100 - 200,000	59.5%
Swoop™	\$100 - 200,000	60.7%

SIN 711-18

Product: Selected Seating and approved Herman Miller Options Products

Standard Lead Time	Single Order Net Purchase	Discount From List
Aeron®	\$100 - 200,000	64.5%
Aside®	\$100 - 200,000	64.2%
Caper®	\$100 - 200,000	61.5%
Celle®	\$100 - 200,000	59.7%
Cosm™	\$100 - 200,000	61.7%
Embody®	\$100 - 200,000	59.7%
Keyn	\$100 - 200,000	57.7%
Lino™	\$100 - 200,000	63.7%
Mirra® 2	\$100 - 200,000	61.7%
Sayl®	\$100 - 200,000	62.2%
Setu®	\$100 - 200,000	59.7%
Verus™	\$100 - 200,000	63.7%

SIN 711-99

Product: Selected Exclave™, Locale®, Public Office Landscape®, Resolve® System, and approved Herman Miller Options Products

Standard Lead Time	Single Order Net Purchase	Discount From List
Exclave	\$100 - 50,000	61.7%
Intent Solution	\$100 - 50,000	58.7%
Locale	\$100 - 50,000	63.7%
Public Office Landscape	\$100 - 50,000	61.7%
Resolve System	\$100 - 50,000	69.8%

Contract Information

continued

7. Quantity Discounts

Reference item #6.

8. Payment Term

Net 30 days

9. Government Commercial Credit Card

- a. Government commercial credit cards are accepted below the micropurchase threshold.
- b. Government commercial credit cards are accepted above the micropurchase threshold.

10. Foreign Items

None

11. Time of Delivery

- a. 90 day ARO
- b. Expedited delivery: Items listed in the 10-Day section of the catalogs are available for expedited delivery.
- c. Overnight/2-day delivery: Select items may be available for overnight or 2-day delivery. Contact Herman Miller or a participating dealer for availability and rates.
- d. Urgent requirements: Agencies may contact contractor or participating dealer to request faster delivery.

12. F.O.B.

F.O.B. destination except Alaska, Hawaii, and Puerto Rico, which will be shipped F.O.B. inland carrier point of exportation.

13. Ordering Address

- a. Herman Miller, Inc.,
Government Customer Care 0161
855 East Main Avenue
Zeeland MI 49464.
- b. For supplies and services, the ordering procedures information on Blanket Purchase Agreements (BPA's) and a sample BPA can be found at the GSA/FSS Schedule homepage (www.fss.gsa.gov/schedules).

14. Payment Address.

Herman Miller, Inc.
22764 Network Place
Chicago, IL 60673-1227

15. Warranty

Herman Miller, Inc., commercial warranty applies.

16. Export Packing Charge

Prices supplied on request.

17. Terms and Conditions of Government Purchase Card Acceptance (any thresholds above the micropurchase level)

None.

18. Rental Maintenance and Repair Terms

Not applicable

19. Terms and Conditions of Installation

Installation Services will be provided by Herman Miller, Inc., or its participating dealer based on a fee not to exceed \$55 per hour (\$82.50 per hour for after-hours Installation), which applies to services totaling \$150,000 (per SIN) and below only. Services above \$150,000 shall be negotiated on a case-by-case basis.

Additional Notes for Installation & Reconfiguration and Relocation Services:

FOB Destination (Drop Ship): Price includes product delivery to the site, brought to the tailgate of the truck. The purchaser is responsible for unloading.

Prices effective up to the maximum order by SIN only. Above the MO, pricing shall be negotiated on a case-by-case basis between the client and local dealer.

Standard Services are Subject to the Following Conditions:

Installation will be performed during normal weekday working hours.

Adequate facilities for delivery, unloading, moving and staging/storing the product during the installation process shall be provided.

Service work will not be hindered by other trades.

Electric, heat, and adequate elevator service will be furnished without charge.

The immediate installation area shall be complete and free of debris including the carpet/flooring before installation commences.

Any work requiring a licensed electrician is the responsibility of the buyer.

Additional Charges May Apply For:

Major Metro Markets and any non-ground floor installation.

Major Metro Markets include large population centers and urban environments.

Installation in a clinical/medical environment.

Special restrictions or limits established by local laws, ordinances or the directions of the buyer, including but not limited to restrictions on transportations of materials, street access to the job site and/or dock facilities.

Installations outside of a 50 mile radius of the servicing dealer.

Local Prevailing Wage and/or Union Labor Rates.

Any additional charges shall be quoted by the dealer and approved by the buyer prior to performance of the work.

Contract Information

continued

20. Terms and Conditions of Repair Parts

Not applicable

21. Service and Distribution Points

For service and distribution points nearest you, call (800) 851 1196.

22. Participating Dealers

Access Herman Miller web site for current list of participating dealers: www.HermanMiller.com/government.

23. Preventive Maintenance

Not applicable

24a. Special Attributes.

2018

Herman Miller receives the Corporation of the Year—Consumer Products award from the Michigan Minority Supplier Development Council.

Herman Miller achieves the Advanced Excellence in Supplier Diversity Award from the Great Lakes Women’s Business Council for doing business with women-owned suppliers.

As one of the top-scoring companies in the industry for the fourteenth consecutive year, Herman Miller has qualified for inclusion in RobecoSAM’s 2018 Sustainability Yearbook and received the Silver Class distinction for excellent sustainability performance—economic, environmental, and social.

Aeron receives Good Design Award from The Chicago Athenaeum Museum of Architecture and Design.

The Cosm Chair won the 2018 Best of NeoCon Gold Award in the Ergonomic Seating Category, the Interior Design HiP Award in the Ergonomic Seating Category, and a #MetropolisLikes Award. Cosm also won Mix Interiors “Product of the Year—Task” award.

For the 11th consecutive year, Herman Miller received a perfect score on the Corporate Equality Index and we were designated as Best Place to Work for LGBT equality. This report evaluates U.S. companies in terms of diversity, particularly their LGBT-related policies and practices.

2017

Herman Miller was named the 2017 “Corporation of the Year” in the consumer products sector by the Michigan Minority Supplier Development Council (MMSDC).

Herman Miller has received a 2017 SEAL (Sustainability, Environmental Achievement and Leadership) Business Sustainability Award.

Herman Miller has earned the 4 Star Diversity Visionary Award. This award celebrates the diversity, equality, and inclusion work of Herman Miller. The award is presented at the annual Diversity Equity Inclusion Summit, held by the Grand Rapids Area Chamber of Commerce.

Herman Miller named one of the Best and Brightest in Wellness for the fifth year in a row.

Working Mother magazine has recognized Herman Miller as one of the 2017 Working Mother 100 Best Companies.

Herman Miller earned our tenth consecutive perfect score in Human Rights Campaign (HRC) Foundation’s 2017 Corporate Equality Index.

As one of the top-scoring companies in our industry for the thirteenth consecutive year, Herman Miller has qualified for inclusion in RobecoSAM’s 2017 Sustainability Yearbook and received the Bronze Class distinction for our excellent economic, environmental, and social sustainability performance.

Herman Miller has once again earned the WorldatWork Seal of Distinction, a unique standard of excellence in work-life effectiveness that shows we provide a distinct, mutually beneficial workplace experience.

2016

Herman Miller was recognized as the Business of the Year at the Annual Meeting of the West Michigan Environmental Action Council (WMEAC). This award goes to the business with the greatest depth and breadth of support, unwavering dedication to environmental action in West Michigan, and a strong corporate commitment to environmental advocacy.

The 101 Best and Brightest Sustainable Companies once again (fifth consecutive year) recognized Herman Miller as an organization in Michigan (and for the first time, in the nation) that exhibits leadership and innovation in its approach to sustainability.

Herman Miller has been recognized by the Michigan Minority Supplier Development Council (MMSDC), as a “Corporation of the Year”, and we also received a “2016 Excellence in Supplier Diversity Award” from the Great Lakes Women’s Business Council. Additionally, we are the only West Michigan company this year to receive an “Ambassadors Championing Excellence” Award from the MMSDC.

Plex Lounge Furniture from Herman Miller receives #MetropolisLikes award at NeoCon 2016.

Plex Lounge Furniture from Herman Miller receives Interior Design HiP Award for Workplace Seating/Lounge at NeoCon 2016.

Spot Stools from Herman Miller Collection receive Interior Design HiP Award for Hospitality Seating at NeoCon 2016.

Contract Information

continued

Herman Miller has been named a 2020 Women on Boards Winning Company. Companies selected for this recognition are considered champions of board diversity as 20 percent or more of their board seats are occupied by women.

Herman Miller selected for inclusion in the 2016 RobecoSAM Sustainability Yearbook for twelfth consecutive year.

Herman Miller again earns the WorldatWork Work-Life 2016 Seal of Distinction. This award identifies organizations that focus on programs that promote work-life balance and overall well-being.

2015

Herman Miller earns ninth consecutive perfect score in Human Rights Campaign (HRC) Foundation's 2016 Corporate Equality Index and we were designated as Best Place to Work for LGBT equality.

This is the fourth consecutive year that Herman Miller was named one of Michigan's Best and Brightest Sustainable Companies.

Herman Miller has received the Best and Brightest in Wellness Award for the third year in a row. This program is an innovative initiative that recognizes and celebrates quality and excellence in health awareness.

Herman Miller received the Forest Stewardship Council (FSC) Leadership Award for longstanding commitment to manufacturing with wood sourced from responsibly managed forests, which reduces environmental impacts by protecting against deforestation and forest degradation.

Herman Miller accepted its second Excellence in Reusable Packaging Award from the Reusable Packaging Association.

Herman Miller has once again been recognized for its commitment to best-in-class economic, environmental, and societal sustainability, earning a spot on the prestigious Dow Jones Sustainability Index (DJSI) for the twelfth consecutive year. We are the only contract furniture company recognized globally for its corporate sustainability leadership.

Herman Miller selected for inclusion in the 2015 RobecoSAM Sustainability Yearbook; awarded Bronze Class distinction for excellent sustainability performance for the second consecutive year.

Herman Miller received a Michigan Business Pollution Prevention (MBP₃) Certificate – a recognition given by the Michigan Department of Environmental Quality (MDEQ) to organizations committed to environmental stewardship, conservation, and sustainable operations. This basic partnership with the MDEQ, which we've maintained since 1998, makes us eligible for our Clean Corporate Citizen (CCC) status that began in 2004 and our Environmental Leader status, which we received for the first time this past year.

MedAssets named Herman Miller Healthcare as Platinum Suppliers. MedAssets, a large group purchasing organization, helps providers enhance operational and financial performance so they can sustainably serve the needs of their community.

Herman Miller honored with five of 20 spots for the Michigan Environmental Leaders Award by the Michigan Department of Environmental Quality for our outstanding, voluntary environmental stewardship.

Renew Sit-to-Stand tables recognized on Record Products 2014 list by Architectural Record.

Herman Miller was again awarded a perfect score in the 2015 Corporate Equality Index. This is the eighth consecutive year we received a perfect score.

2014

Herman Miller has received the Best and Brightest in Wellness Award for the second year in a row. This program is an innovative initiative that recognizes and celebrates quality and excellence in health awareness.

Herman Miller's Locale wins International Design Excellence Awards (IDEA) Gold in the Office & Productivity category.

Herman Miller achieves eleventh consecutive listing on Dow Jones Sustainability World Index, an international stock portfolio that evaluates the annual performance of the world's largest 2500 companies using economic, environmental, and social criteria, known as the "triple bottom line" of sustainability.

2013

Herman Miller achieves tenth consecutive listing on Dow Jones Sustainability World Index.

Herman Miller has received the Best and Brightest in Wellness Award. This program is an innovative initiative that recognizes and celebrates quality and excellence in health awareness.

Herman Miller Earns Perfect Score on the Corporate Equality Index. We are one of only 303 major U.S. businesses to receive a perfect score in 2013, an achievement we have now obtained seven years in a row.

Herman Miller is listed in Forbes Magazine inaugural "Platinum List" of America's 400 best managed, large companies.

For the second consecutive year, Herman Miller is honored as one of West Michigan's "101 Best and Brightest Sustainable Companies".

2012

Herman Miller accepted its first Excellence in Reusable Packaging Award from the Reusable Packaging Association.

Contract Information

continued

Herman Miller is named “Corporation of the Year” in the commercial products sector by the Michigan Minority Supplier Development Council.

In July 2012 Herman Miller was inducted into the Made in the USA Hall of Fame. Herman Miller is one of only 20 companies across the nation to receive this distinction.

Herman Miller achieves ninth consecutive listing on Dow Jones Sustainability World Index.

Herman Miller is honored as one of West Michigan’s 101 Best and Brightest Sustainable Companies.

The Sustainable Asset Management (SAM) group selected Herman Miller for inclusion in “The Sustainability Yearbook 2012” and has awarded Herman Miller both the “SAM Sector Leader” and “SAM Sector Mover” distinctions.

Herman Miller was named one of 16 Section Leaders on Climate Counts 2011-2012 Scorecard Report, making us the industry leader for Home and office Furnishings.

SGS International Certification Services, Inc., recognizes Herman Miller’s manufacturing sites, Midwest Distribution Center, and Design Yard for initial certification to the OHSAS 18001 standard as well as re-certification to ISO 14001.

2011

Trust Across America, a company dedicated to unraveling the complexities of trustworthy business behavior, listed Herman Miller as one of their “Top Ten Most Trustworthy Companies in America 2011.”

The U.S. Environmental Protection Agency (EPA) selected Herman Miller, as a WasteWise Gold Achievement—Climate Change winner.

Herman Miller achieves eighth consecutive listing on Dow Jones Sustainability World Index, an international stock portfolio that evaluates the annual performance of the world’s largest 2500 companies using economic, environmental, and social criteria, known as the “triple bottom line” of sustainability.

The Michigan Minority Supplier Development Council (MMSDC) named Herman Miller as its “Corporation of the Year” in the commercial products sector. This was the fifth time Herman Miller has received this award since 2005.

Herman Miller accepted its third Neighborhood Environmental Partners (NEP) award from the Michigan Department of Natural Resources and Environment.

Herman Miller receives the Reader’s Choice award from TreeHugger’s Best of Green: Design and Architecture category for the SAYL chair.

Herman Miller earns Citibank’s Global Environmental Vendor of the Year award.

The SAYL chair from Herman Miller was dubbed the “Product Design of the Year” from the 2010 International Design Awards (IDA) jury.

Herman Miller Healthcare’s Compass system was awarded a 2011 Medical Design Excellence Award (MDEA) for its research-based design and ability to be used in a variety of healing spaces, while simultaneously improving the overall delivery of healthcare.

The Sustainable Asset Management (SAM) Group selected Herman Miller for inclusion in the “Sustainability Yearbook 2011” and awarded us both the “SAM Sector Leader” and “SAM Sector Mover” distinctions.

Herman Miller has received the top rating for a fourth consecutive year in the Human Rights Campaign (HRC) Foundation’s eighth annual Corporate Equality Index. The “Best Places to Work for LGBT Equality” distinction is awarded to businesses that scored 100% on the HRC Foundation’s 2011 Corporate Equality Index.

Herman Miller again tops contract furniture industry in FORTUNE’s ‘Most Admired’ Companies survey. For the 23rd time in 25 years.

24b. Section 508 Compliance

Not applicable

25. Data Universal Numbering System (DUNS): 00-601-2801

26. Registered in System for Award Management (www.SAM.gov) Database

27. Cancellation

Prior to production, no cancellation charge will apply. After production, only actual cost incurred that the contractor can demonstrate if items are sold after 3 months.

28. Restocking Charges

Agencies must notify the contractor for authorization prior to returning any items. The customer agency will be required to pay all packaging and return freight charges. A restocking fee of 50% for Systems Furniture and 35% for all other product lines will be charged for any returned items.

Herman Miller Miscellaneous Information:

Federal ID Number: 38-0837640

Commercial and Government Entity Code (CAGE): 40636

Data Universal Numbering System (DUNS) 00-601-2801

Commercial Entity Code (CEC): 00702290J

Introduction	page 2
Tu® Metal Storage	3
Pedestals	5
Pedestal Accessories	61
Lateral Files	69
Overfiles	84
File Tops	90
Lateral File Accessories	92
Storage Towers	99
Tower Accessories	123
Storage Cases	130
Bookcases	139
Keyless Locks	142
Indices	145
By Name	145
By Number	147
Appendices	
20-Day or Less/Assigned Lead-Time Order Information	
Keyed-Alike Information	
Stain-to-Match Program	
Customer's Own Material/Customer's Own Leather Order Information-Cushion Tops	
For the latest materials information, refer to the Materials pages on HermanMiller.com.	

Introduction

A Note on the Organization of This Book

There are a few signals that will help you understand the organization of this book. Once you know them, you should be able to find your way around easily.

Like a newspaper, this book is formatted with columns of text and illustrations that run vertically.

Information wraps from one column to the next and continues for as many pages as it needs to.

Black bars are clues.

A black bar at the top of a page signals the start of information about a product.

This information is divided into two sections, each signaled by a black bar. Product Information includes a description, additional notes, and dimensional drawings. Specification Information, which always begins at the top of a column, includes a series of steps. Each step represents a decision you need to make in order to complete your product number. Steps must be followed sequentially. The number of pages needed to complete information on a product varies; some will be complete in one page; others may fill three or four pages. Just continue going through the steps until you run into the next product, signaled by the black bar at the top of the page.

Black tabs running along the outside edge of the page help you locate what section you are in or what section you want to go to. You can thumb forwards or backwards to find a section; tabs and text appear on both sides of the page.

The additional pages in the back of the book include the appendices and indices. They are signaled by a long black bar running along the outside edge of the page.

The index is presented two ways.

The first index is in alphabetical order by product name. It can be helpful if you are new to the products and numbering scheme or if you are looking for a type of product, such as work chair or round table.

The second index is by product number. It lists, in alphanumeric order, the base product number, typically a five-digit number.

General Information

This book is effective April 1, 2019, subject to change without notice. Products may be purchased from authorized Herman Miller dealers who will quote prices upon request. For more information about our products and services or to see a list of dealers, visit www.HermanMiller.com.

All prices are list prices. Additional services, such as planning services, design, storage, and installation, are not included and must be added to these prices when the additional services are requested.

Illustrations, specifications, and prices are based on the latest information at the time of publication. The right is reserved to make changes at any time without notice in prices, fabrics, finishes, materials, specifications, and models, and also to discontinue models and finishes.

Dimensions shown in the drawings are engineering drawing dimensions rounded up to the nearest $\frac{1}{8}$ ". Product is shipped set up or knocked down. Products that include "Shipped knocked down" in the description require some assembly. If this statement does not appear in the description, the product is shipped assembled.

Service problems are normally handled by a Herman Miller authorized dealer. Where this cannot be accomplished on a local level, service problems should be referred to the Customer Care Representative for your region, Herman Miller, Inc., Zeeland, Michigan 49464.

20-Day or Less/Assigned Lead-Time Shipments

All products and options in this price book not designated by an Assigned Program icon  will ship in **20 business days or less** after being acknowledged by Herman Miller.

Products and options designated by an  are on the assigned lead-time program and may ship in 20 days, less than 20 days, or more than 20 days from order acknowledgement.

Metal Storage

Keyless Locks



Bar-Pull Freestanding Pedestal

LK10A.
LK10D.

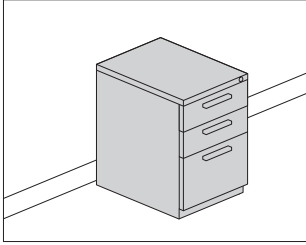

Product Information

Description

This freestanding pedestal fits below a hanging or freestanding work surface. It has a painted or veneer front, smooth-steel case, applied metal bar pulls, and 1" leveling glides. A counterweight is included. Actual pedestal depth is 19³/₈", 23¹/₄", or 27¹/₄". Standard-height pedestal is 26³/₈" high; raised-height pedestal is 27¹/₄" high. Raised-height configuration adds 7⁷/₈" to overall height to fill the space between the top of the pedestal and the underside of a surface. Box drawers are available with 3⁴/₄-extension or full-extension slides. File drawers have full-extension slides and hold letter-size front-to-back hanging files.

Notes

To add drawer divider, pencil tray, and file converters to drawer interiors, specify option (2M) or (3M).

For full extension slides on box drawers, specify option (SB).

Base on 2 drawers, raised height option (1) aligns with base on Tu® storage towers.

Pedestal will not fit below the following products:

- Action Office® table
 - Ethospace® round-end peninsula with access
- 24"-deep pedestal will not fit below the following products:
- 24"-deep Ethospace work surface with cable management trough
 - Action Office 60"-wide work surface

28"-deep pedestal will not fit below the following products:

- 30"-deep Ethospace work surface with cable management trough
- Action Office 60"-wide work surface

Grain direction is vertical for veneer-front pedestals.

Order optional accessories separately:

- Drawer divider (LG903.)
- File compressor (LG908)
- File converter (LG907)
- File drawer organizer (LG901)
- Pedestal stationery divider (LG905)
- Utility tray (LG906)
- Storage organizer (LG910)

Storage organizer includes a hanging file holder, utility tray (pencil tray) and 2 containers. Storage organizer frame color matches drawer interior; file holder and containers are g1 white; utility tray is black.

For keyed-alike locks, order lock plugs separately. See Keyed-Alike Information in Appendices.

Dimensions

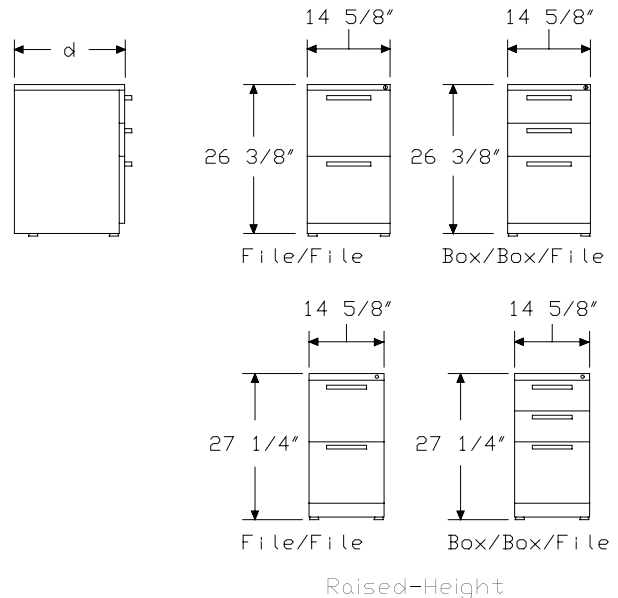

Bar-Pull Freestanding Pedestal

continued

Tu® Metal Storage

Specification Information

Step 1.

LK10

Step 2. Front Material

- D.** painted metal front
- A.** veneer front A

Step 3. Depth

- 20** 20" deep
- 24** 24" deep
- 28** 28" deep

Step 4. Configuration

- BBF** box/box/file
- FF** file/file

Prices for Steps 1-4.

	BBF	FF
LK10D. 20	\$659	677
24	\$697	714
28	\$761	778
LK10A. 20	\$892	911
24	\$929	948
28	\$997	1014

Step 5. Slides

For box/box/file (BBF)

- SR** ¾-extension roller slides on box drawer, full-extension ball bearing on file drawer +\$0
- SB** full-extension ball-bearing +\$50

For file/file (FF)

- SB** full-extension ball-bearing +\$0

Step 6. Paint/Steel Type

- SS** smooth paint on smooth steel +\$0
- XS** textured paint on smooth steel +\$0

Step 7. Surface Finish

For smooth paint on smooth steel (SS)

- 98** studio white +\$0
- 8Q** folkstone grey +\$0
- BU** black umber +\$0
- HF** inner tone light +\$0
- LT** light tone +\$0
- LU** soft white +\$0
- MT** medium tone +\$0
- SG** slate grey +\$0
- WL** sandstone +\$0
- CN** metallic champagne +\$0
- EH** metallic bronze +\$0
- MS** metallic silver +\$0

Sand Texture Paint

For textured paint on smooth steel (XS)

- 91** white +\$0
- 98** studio white +\$0
- BK** black +\$0
- CL** cool grey neutral +\$0
- G1** graphite +\$0
- WN** warm grey neutral +\$0

Step 8. Front Finish

For veneer front (A.)

Recut Veneer

- RA** light ash A +\$0
- RK** mahogany dark A +\$0
- RM** mahogany A +\$0

Wood Veneer

- 2U** light brown walnut A +\$107
- 40** dark brown walnut A +\$107
- ED** aged cherry A +\$107
- EK** medium red walnut A +\$107
- EW** medium matte walnut A +\$107
- ET** clear on ash A +\$107
- EV** walnut on ash A +\$107
- UL** natural maple A +\$107
- UX** walnut on cherry A +\$107

Bar-Pull Freestanding Pedestal

continued

Step 9. Lock		
KA	keyed alike	-\$10
KC	keyed differently, chrome	+\$0
KD	keyed differently, black	+\$0

Step 10. Pull Finish		
Metallic Paint		
CN	metallic champagne	+\$0
MS	metallic silver	+\$0

Sand Texture Paint		
79	green apple	+\$15
BK	black	+\$0
MY3	yellow oxide	+\$15
RO	red	+\$15
TRQ	turquoise	+\$15

Smooth Paint		
8Q	folkstone grey	+\$0
91	white	+\$0
98	studio white	+\$0
G1	graphite	+\$0
WL	sandstone	+\$0

Step 11. Base Height		
1F	standard height	+\$0
2F	raised height	+\$0

Step 12. Drawer Interior		
For box/box/file (BBF)		
NN	none	+\$0
2M	drawer divider in box drawers, 2 file converters in file drawer	+\$25
3M	drawer divider in one box drawer, pencil tray in one box drawer, 2 file converters in file drawer	+\$25
C51	storage organizer including hanging file holder bin, utility tray and two containers <input type="checkbox"/>	+\$120

For file/file (FF)		
NN	none	+\$0
1M	2 file converters in each file drawer	+\$25
C51	storage organizer including hanging file holder bin, utility tray and two containers <input type="checkbox"/>	+\$120

Arc Pull Freestanding Pedestal

LQ10A.
LQ10D.

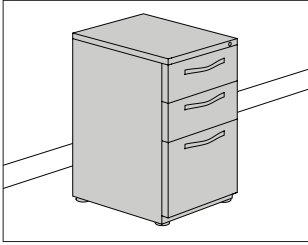

Tu® Metal Storage

Product Information

Description

This freestanding pedestal fits below a hanging or freestanding work surface. It has a painted or veneer front, smooth-steel case, applied metal arc pulls, and 1" leveling glides. A counterweight is included. Actual pedestal depth is 19³/₈", 23³/₄", or 27³/₄". Standard-height pedestal is 26³/₈" high; raised-height pedestal is 27¹/₄" high. Raised-height configuration adds 7/₈" to overall height to fill the space between the top of the pedestal and the underside of a surface. Box drawers are available with 3/₄-extension or full-extension slides. File drawers have full-extension slides and hold letter-size front-to-back hanging files.

Notes

Pull design conforms to guidelines of Americans with Disabilities Act (ADA).

To add drawer divider, pencil tray, file converters and storage organizer to drawer interiors, specify option (1M), (2M), (3M) or (C51).

For full extension slides on box drawers, specify option (SB).

Base on 2 drawers, raised height option (1) aligns with base on Tu® storage towers.

Pedestal will not fit below the following products:

- Action Office® table
- Ethospace® round-end peninsula with access

24"-deep pedestal will not fit below the following products:

- 24"-deep Ethospace work surface with cable management trough
- Action Office 60"-wide work surface

28"-deep pedestal will not fit below the following products:

- 30"-deep Ethospace work surface with cable management trough
- Action Office 60"-wide work surface

Grain direction is vertical for veneer-front pedestals.

Order optional accessories separately:

- Drawer divider (LG903.)
- File compressor (LG908)
- File converter (LG907)
- File drawer organizer (LG901)
- Pedestal stationery divider (LG905)
- Utility tray (LG906)
- Storage organizer (LG910)

Storage organizer includes a hanging file holder, utility tray (pencil tray) and 2 containers. The storage organizer frame color matches the drawer interior; file holder and containers are 91 white; utility tray is black.

For keyed-alike locks, order lock plugs separately. See Keyed-Alike Information in Appendices.

Dimensions

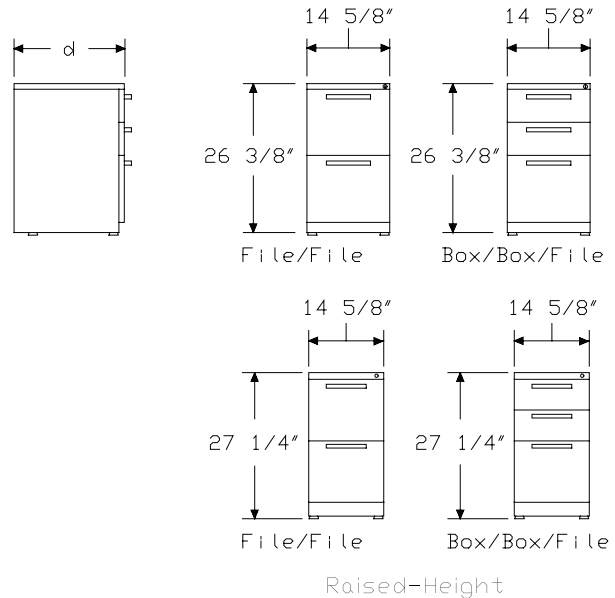

Arc Pull Freestanding Pedestal

continued

Specification Information

Step 1.

LQ10

Step 2. Front Material

- D.** painted metal front
- A.** veneer front A

Step 3. Depth

- 20** 20" deep
- 24** 24" deep
- 28** 28" deep

Step 4. Configuration

- BBF** box/box/file
- FF** file/file

Prices for Steps 1-4.

	BBF	FF
LQ10D. 20	\$659	677
24	\$697	714
28	\$761	778
LQ10A. 20	\$892	911
24	\$929	948
28	\$997	1014

Step 5. Slides

For box/box/file (BBF)

- SR** ¾-extension roller slides on box drawer, full-extension ball bearing on file drawer +\$0
- SB** full-extension ball-bearing +\$50

For file/file (FF)

- SB** full-extension ball-bearing +\$0

Step 6. Paint/Steel Type

- SS** smooth paint on smooth steel +\$0
- XS** textured paint on smooth steel +\$0

Step 7. Surface Finish

For smooth paint on smooth steel (SS)

- 8Q** folkstone grey +\$0
- 98** studio white +\$0
- BU** black umber +\$0
- CN** metallic champagne +\$0
- EH** metallic bronze +\$0
- HF** inner tone light +\$0
- LT** light tone +\$0
- LU** soft white +\$0
- MS** metallic silver +\$0
- MT** medium tone +\$0
- SG** slate grey +\$0
- WL** sandstone +\$0

Sand Texture Paint

For textured paint on smooth steel (XS)

- 91** white +\$0
- 98** studio white +\$0
- BK** black +\$0
- CL** cool grey neutral +\$0
- G1** graphite +\$0
- WN** warm grey neutral +\$0

Step 8. Front Finish

For veneer front (A.)

Recut Veneer

- RA** light ash A +\$0
- RK** mahogany dark A +\$0
- RM** mahogany A +\$0

Wood Veneer

- 2U** light brown walnut A +\$107
- 40** dark brown walnut A +\$107
- ED** aged cherry A +\$107
- EK** medium red walnut A +\$107
- EW** medium matte walnut A +\$107
- ET** clear on ash A +\$107
- EU** oak on ash A +\$107
- EV** walnut on ash A +\$107
- UL** natural maple A +\$107
- UX** walnut on cherry A +\$107

Arc Pull Freestanding Pedestal

continued

Tu® Metal Storage

Step 9. Lock

KA	keyed alike	-\$10
KC	keyed differently, chrome	+\$0
KD	keyed differently, black	+\$0

Step 10. Pull Finish

NH	brushed nickel	+\$0
NK	black nickel	+\$0

Step 11. Base Height

1F	standard height	+\$0
2F	raised height	+\$0

Step 12. Drawer Interior

For 20" deep (20) or 24" deep (24) with box/box/file (BBF)

NN	none	+\$0
2M	drawer divider in box drawers, 2 file converters in file drawer	+\$25
3M	drawer divider in one box drawer, pencil tray in one box drawer, 2 file converters in file drawer	+\$25
C51	storage organizer including hanging file holder bin, utility tray and two containers A	+\$120

For 28" deep (28) with box/box/file (BBF)

NN	none	+\$0
2M	drawer divider in box drawers, 2 file converters in file drawer	+\$25
3M	drawer divider in one box drawer, pencil tray in one box drawer, 2 file converters in file drawer	+\$25

For 20" deep (20) or 24" deep (24) with file/file (FF)

NN	none	+\$0
1M	2 file converters in each file drawer	+\$25
C51	storage organizer including hanging file holder bin, utility tray and two containers A	+\$120

For 28" deep (28) with file/file (FF)

NN	none	+\$0
1M	2 file converters in each file drawer	+\$25

W-Pull Freestanding Pedestal

LW100.

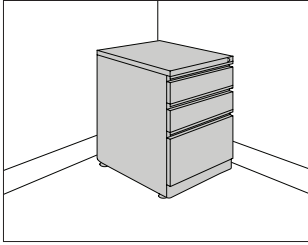

Product Information

Description

This freestanding pedestal fits below a hanging or freestanding work surface. It has a smooth-steel case, full-width pulls, and 1" leveling glides. Counterweight is included.

Actual pedestal depth is 19³/₈", 23¹/₄", or 27³/₄". Standard-height pedestal is 26³/₈" high; raised-height pedestal is 27¹/₄" high. Raised-height configuration adds 7⁷/₈" to overall height to fill the space between the top of the file and the underside of a surface.

Drawers are available with full-extension or 3/4-extension slides. A drawer divider, utility tray or storage organizer is optional for box drawers. File drawers hold letter-size front-to-back hanging files. File converters are optional for letter-, legal-, and A4-size side-to-side hanging files.

Notes

Base on 2 drawers, raised height option (1) aligns with base on Tu® storage towers.

Pedestal will not fit below the following products:

- Action Office® table
 - Ethospace® round-end peninsula with access
- 24"-deep pedestal will not fit below the following products:
- 24"-deep Ethospace work surface with cable management trough
 - Action Office 60"-wide work surface

28"-deep pedestal will not fit below the following products:

- 30"-deep Ethospace work surface with cable management trough
- Action Office 60"-wide work surface

Order optional accessories separately:

- Drawer divider (LG903.)
- File compressor (LG908)
- File converter (LG907)
- File drawer organizer (LG901)
- Pedestal stationery divider (LG905)
- Utility tray (LG906)
- Storage organizer (LG910)

Storage organizer includes a hanging file holder, utility tray (pencil tray) and 2 containers. The storage organizer frame color matches the drawer interior; file holder and containers are 91 white; utility tray is black.

For keyed-alike locks, order lock plugs separately. See Keyed-Alike Information in Appendices.

Dimensions

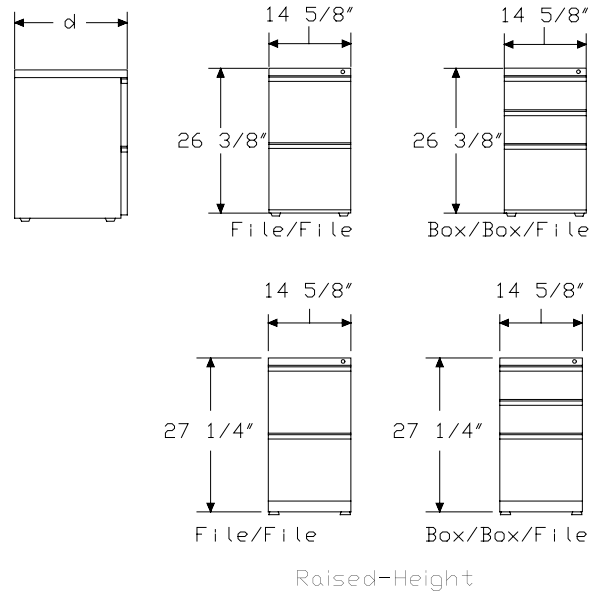

W-Pull Freestanding Pedestal

continued

Tu® Metal Storage

Specification Information		
Step 1.		
LW100.		
Step 2. Depth		
20	20" deep	
24	24" deep	
28	28" deep	
Step 3. Configuration		
BBF	box/box/file	
FF	file/file	
Prices for Steps 1-3.		
		BBF FF
LW100. 20		\$568 520
24		\$581 535
28		\$652 602
Step 4. Slides		
<i>For box/box/file (BBF)</i>		
SR	3/4"-extension roller slides on box drawer, full-extension ball bearing on file drawer	+\$0
SB	full-extension ball-bearing	+\$50
<i>For file/file (FF)</i>		
SB	full-extension ball-bearing	+\$0
Step 5. Paint/Steel Type		
SS	smooth paint on smooth steel	+\$0
XS	textured paint on smooth steel	+\$0

Step 6. Surface Finish		
<i>For smooth paint on smooth steel (SS)</i>		
8Q	folkstone grey	+\$0
98	studio white	+\$0
BU	black umber	+\$0
CN	metallic champagne	+\$0
EH	metallic bronze	+\$0
HF	inner tone light	+\$0
LT	light tone	+\$0
LU	soft white	+\$0
MS	metallic silver	+\$0
MT	medium tone	+\$0
SG	slate grey	+\$0
WL	sandstone	+\$0
Sand Texture Paint		
<i>For textured paint on smooth steel (XS)</i>		
91	white	+\$0
98	studio white	+\$0
BK	black	+\$0
CL	cool grey neutral	+\$0
G1	graphite	+\$0
WN	warm grey neutral	+\$0
Step 7. Lock		
KA	keyed alike	-\$10
KC	keyed differently, chrome	+\$0
KD	keyed differently, black	+\$0
Step 8. Base Height		
1F	standard height	+\$0
2F	raised height	+\$0
Step 9. Drawer Interior		
<i>For 20" deep (20) or 24" deep (24) with box/box/file (BBF)</i>		
NN	none	+\$0
2M	drawer divider in box drawers, 2 file converters in file drawer	+\$25
3M	drawer divider in one box drawer, pencil tray in one box drawer, 2 file converters in file drawer	+\$25
C51	storage organizer including hanging file holder bin, utility tray and two containers A	+\$120

W-Pull Freestanding Pedestal

continued

For 28" deep (28) with box/box/file (BBF)

NN	none	+\$0
2M	drawer divider in box drawers, 2 file converters in file drawer	+\$25
3M	drawer divider in one box drawer, pencil tray in one box drawer, 2 file converters in file drawer	+\$25

For 20" deep (20) or 24" deep (24) with file/file (FF)

NN	none	+\$0
1M	2 file converters in each file drawer	+\$25
C51	storage organizer including hanging file holder bin, utility tray and two containers A	+\$120

For 28" deep (28) with file/file (FF)

NN	none	+\$0
1M	2 file converters in each file drawer	+\$25

V-Pull Freestanding Pedestal

LV100.

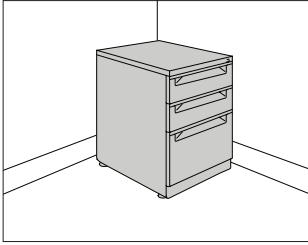

Tu® Metal Storage

Product Information

Description

This freestanding pedestal fits below a hanging or freestanding work surface. It has a smooth-steel case, full-width recessed pulls, and 1" leveling glides. Counterweight is included.

Actual pedestal depth is 19³/₈", 23³/₄", or 27³/₄". Standard-height pedestal is 26³/₈" high; raised-height pedestal is 27¹/₄" high. Raised-height configuration adds 7/₈" to overall height to fill the space between the top of the pedestal and the underside of a surface.

Drawers are available with full-extension or 3/₄-extension slides. A drawer divider, utility tray or storage organizer is optional for box drawers. File drawers hold letter-size front-to-back hanging files. File converters are optional for letter-, legal-, and A4-size side-to-side hanging files.

Notes

Base on 2 drawers, raised height option (1) aligns with base on Tu® storage towers.

Pedestal will not fit below the following products:

- Action Office® table
 - Ethospace® round-end peninsula with access
- 24"-deep pedestal will not fit below the following products:
- 24"-deep Ethospace work surface with cable management trough
 - Action Office 60"-wide work surface

28"-deep pedestal will not fit below the following products:

- 30"-deep Ethospace work surface with cable management trough
- Action Office 60"-wide work surface

Order optional accessories separately:

- Drawer divider (LG903.)
- File compressor (LG908)
- File converter (LG907)
- File drawer organizer (LG901)
- Pedestal stationery divider (LG905)
- Utility tray (LG906)
- Storage organizer (LG910)

Storage organizer includes a hanging file holder, utility tray (pencil tray) and 2 containers. The storage organizer frame color matches the drawer interior; file holder and containers are 91 white; utility tray is black.

For keyed-alike locks, order lock plugs separately. See Keyed-Alike Information in Appendices.

Dimensions

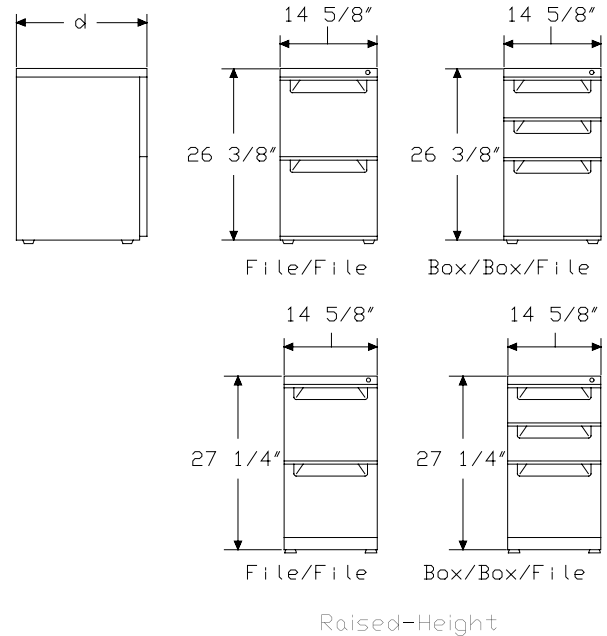

Raised-Height

V-Pull Freestanding Pedestal

continued

Specification Information

Step 1.

LV100.

Step 2. Depth

20	20" deep
24	24" deep
28	28" deep

Step 3. Configuration

BBF	box/box/file
FF	file/file

Prices for Steps 1-3.

	BBF	FF
LV100. 20	\$583	537
24	\$601	550
28	\$673	617

Step 4. Slides

For box/box/file (BBF)

SR	¾-extension roller slides on box drawer, full-extension ball bearing on file drawer	+\$0
SB	full-extension ball-bearing	+\$50

For file/file (FF)

SB	full-extension ball-bearing	+\$0
-----------	-----------------------------	------

Step 5. Paint/Steel Type

SS	smooth paint on smooth steel	+\$0
XS	textured paint on smooth steel	+\$0

Step 6. Surface Finish

For smooth paint on smooth steel (SS)

8Q	folkstone grey	+\$0
98	studio white	+\$0
BU	black umber	+\$0
CN	metallic champagne	+\$0
EH	metallic bronze	+\$0
HF	inner tone light	+\$0
LT	light tone	+\$0
LU	soft white	+\$0
MS	metallic silver	+\$0
MT	medium tone	+\$0
SG	slate grey	+\$0
WL	sandstone	+\$0

Sand Texture Paint

For textured paint on smooth steel (XS)

91	white	+\$0
98	studio white	+\$0
BK	black	+\$0
CL	cool grey neutral	+\$0
G1	graphite	+\$0
WN	warm grey neutral	+\$0

Step 7. Lock

KA	keyed alike	-\$10
KC	keyed differently, chrome	+\$0
KD	keyed differently, black	+\$0

Step 8. Base Height

1F	standard height	+\$0
2F	raised height	+\$0

Step 9. Drawer Interior

For 20" deep (20) or 24" deep (24) with box/box/file (BBF)

NN	none	+\$0
2M	drawer divider in box drawers, 2 file converters in file drawer	+\$25
3M	drawer divider in one box drawer, pencil tray in one box drawer, 2 file converters in file drawer	+\$25
C51	storage organizer including hanging file holder bin, utility tray and two containers A	+\$120

V-Pull Freestanding Pedestal

continued

Tu® Metal Storage

For 28" deep (28) with box/box/file (BBF)

NN	none	+\$0
2M	drawer divider in box drawers, 2 file converters in file drawer	+\$25
3M	drawer divider in one box drawer, pencil tray in one box drawer, 2 file converters in file drawer	+\$25

For 20" deep (20) or 24" deep (24) with file/file (FF)

NN	none	+\$0
1M	2 file converters in each file drawer	+\$25
C51	storage organizer including hanging file holder bin, utility tray and two containers A	+\$120

For 28" deep (28) with file/file (FF)

NN	none	+\$0
1M	2 file converters in each file drawer	+\$25

Bar Pull Mobile Pedestal

LK11A.
LK11D.

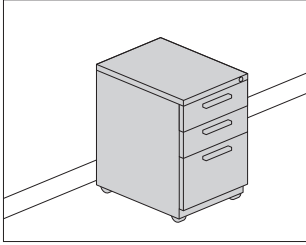

Product Information

Description

This mobile pedestal fits below a hanging or freestanding work surface. It has a painted or veneer front, smooth-steel case, applied metal bar pulls, and black rubber casters. Pedestal can be specified with or without a hand grip. Counterweight is included.

Actual pedestal depth is 19³/₈" or 23¹/₄".

Box drawers are available with 3/4"-extension or full-extension slides.

File drawers have full-extension slides and hold letter-size front-to-back hanging files.

Notes

To add drawer divider, pencil tray, and file converters to drawer interiors, specify option (2M) or (3M).

For full extension slides on box drawers, specify option (SB).

24"-deep pedestal will not fit below the following products:

- 24"-deep Ethospace® work surface with cable management trough
- Action Office® 60"-wide work surface

Grain direction is vertical for veneer-front pedestals.

Order optional accessories separately:

- Drawer divider (LG903.)
- File compressor (LG908)
- File converter (LG907)
- File drawer organizer (LG901)
- Pedestal stationery divider (LG905)
- Utility tray (LG906)
- Storage organizer (LG910)

Storage organizer includes a hanging file holder, utility tray (pencil tray) and 2 containers. Storage organizer frame color matches drawer interior; file holder and containers are 91 white; utility tray is black.

For keyed-alike locks, order lock plugs separately. See Keyed-Alike Information in Appendices.

Dimensions

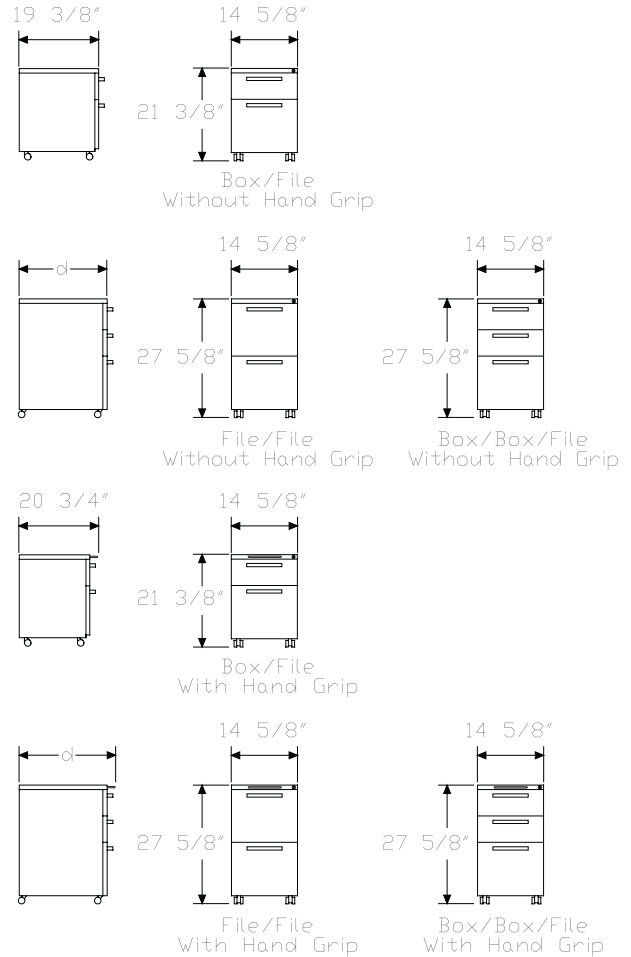

Specification Information			
Step 1.			
LK11			
Step 2. Front Material			
D.	painted metal front		
A.	veneer front <input type="checkbox"/>		
Step 3. Depth			
20	20" deep		
24	24" deep		
Step 4. Configuration			
<i>For 20" deep (20)</i>			
BBF	box/box/file		
BF	box/file		
FF	file/file		
<i>For 24" deep (24)</i>			
BBF	box/box/file		
FF	file/file		
Prices for Steps 1-4.			
	BBF	BF	FF
LK11D. 20	\$724	624	686
24	\$768	—	720
LK11A. 20	\$958	859	921
24	\$1002	—	954
Step 5. Slides			
<i>For box/box/file (BBF)</i>			
SR	3/4-extension roller slides on box drawer, full-extension ball bearing on file drawer		+\$0
SB	full-extension ball-bearing		+\$50
<i>For box/file (BF)</i>			
SR	3/4-extension roller slides on box drawer, full-extension ball bearing on file drawer		+\$0
SB	full-extension ball-bearing		+\$25
<i>For file/file (FF)</i>			
SB	full-extension ball-bearing		+\$0

Step 6. Paint/Steel Type		
SS	smooth paint on smooth steel	+\$0
XS	textured paint on smooth steel	+\$0
Step 7. Surface Finish		
<i>For smooth paint on smooth steel (SS)</i>		
98	studio white	+\$0
8Q	folkstone grey	+\$0
BU	black umber	+\$0
HF	inner tone light	+\$0
LT	light tone	+\$0
LU	soft white	+\$0
MT	medium tone	+\$0
SG	slate grey	+\$0
WL	sandstone	+\$0
CN	metallic champagne	+\$0
EH	metallic bronze	+\$0
MS	metallic silver	+\$0
Sand Texture Paint		
<i>For textured paint on smooth steel (XS)</i>		
91	white	+\$0
98	studio white	+\$0
BK	black	+\$0
CL	cool grey neutral	+\$0
G1	graphite	+\$0
WN	warm grey neutral	+\$0
Step 8. Front Finish		
<i>For veneer front (A.)</i>		
Recut Veneer		
RA	light ash <input type="checkbox"/>	+\$0
RK	mahogany dark <input type="checkbox"/>	+\$0
RM	mahogany <input type="checkbox"/>	+\$0
Wood Veneer		
2U	light brown walnut <input type="checkbox"/>	+\$107
40	dark brown walnut <input type="checkbox"/>	+\$107
ED	aged cherry <input type="checkbox"/>	+\$107
EK	medium red walnut <input type="checkbox"/>	+\$107
EW	medium matte walnut <input type="checkbox"/>	+\$107
ET	clear on ash <input type="checkbox"/>	+\$107
EV	walnut on ash <input type="checkbox"/>	+\$107
UL	natural maple <input type="checkbox"/>	+\$107
UX	walnut on cherry <input type="checkbox"/>	+\$107

Bar Pull Mobile Pedestal *continued*

Step 9. Lock

KA	keyed alike	-\$10
KC	keyed differently, chrome	+\$0
KD	keyed differently, black	+\$0

Step 10. Pull Finish

Metallic Paint

CN	metallic champagne	+\$0
MS	metallic silver	+\$0

Sand Texture Paint

79	green apple	+\$15
BK	black	+\$0
MY3	yellow oxide	+\$15
RO	red	+\$15
TRQ	turquoise	+\$15

Smooth Paint

8Q	folkstone grey	+\$0
91	white	+\$0
98	studio white	+\$0
G1	graphite	+\$0
WL	sandstone	+\$0

Step 11. Drawer Interior

For box/box/file (BBF)

NN	none	+\$0
2M	drawer divider in box drawers, 2 file converters in file drawer	+\$25
3M	drawer divider in one box drawer, pencil tray in one box drawer, 2 file converters in file drawer	+\$25
C51	storage organizer including hanging file holder bin, utility tray and two containers <input type="checkbox"/> A	+\$120

For box/file (BF)

NN	none	+\$0
4M	drawer divider in box drawer, 2 file converters in file drawer	+\$20
5M	pencil tray in box drawer, 2 file converters in file drawer	+\$20
C51	storage organizer including hanging file holder bin, utility tray and two containers <input type="checkbox"/> A	+\$120

For file/file (FF)

NN	none	+\$0
1M	2 file converters in each file drawer	+\$25
C51	storage organizer including hanging file holder bin, utility tray and two containers <input type="checkbox"/> A	+\$120

Step 12. Handle

HN	no hand grip	+\$0
H1	hand grip only	+\$48

Arc Pull Mobile Pedestal

LQ11A.
LQ11D.
LQ11L.

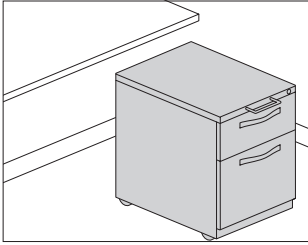

Tu® Metal Storage

Product Information

Description

This mobile pedestal fits below a hanging or freestanding work surface. It has a painted, laminate, or veneer front, smooth-steel case, applied metal arc pulls, and black rubber casters. Pedestal can be specified with or without a hand grip. Counterweight is included.

Actual pedestal depth is 19³/₈" or 23¹/₄".

Box drawers are available with 3/4"-extension or full-extension slides.

File drawers have full-extension slides and hold letter-size front-to-back hanging files.

Notes

Pull design conforms to guidelines of Americans with Disabilities Act (ADA).

To add drawer divider, pencil tray, file converters and storage organizer to drawer interiors, specify option (1M), (2M), (3M), (4M), (5M) or (C51). For full extension slides on box drawers, specify option (SB).

24"-deep pedestal will not fit below the following products:

- 24"-deep Ethospace® work surface with cable management trough
- Action Office® 60"-wide work surface

Accepts Tu® add-on cushion top (LG890).

Grain direction is vertical for veneer-front pedestals.

Order optional accessories separately:

- Drawer divider (LG903.)
- File compressor (LG908)
- File converter (LG907)
- File drawer organizer (LG901)
- Pedestal stationery divider (LG905)
- Utility tray (LG906)
- Storage organizer (LG910)

Storage organizer includes a hanging file holder, utility tray (pencil tray) and 2 containers. The storage organizer frame color matches the drawer interior; file holder and containers are 91 white; utility tray is black.

For keyed-alike locks, order lock plugs separately. See Keyed-Alike Information in Appendices.

Dimensions

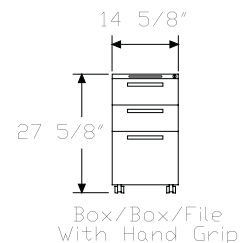
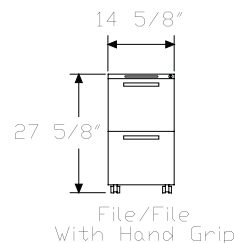
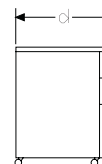
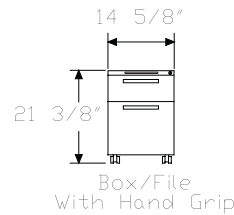
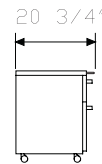
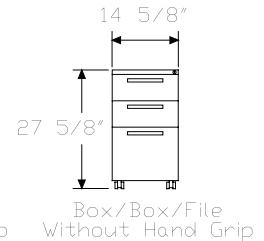
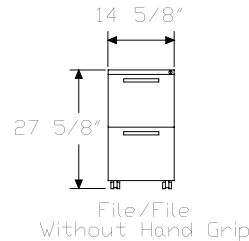
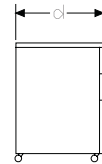
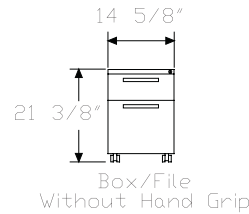
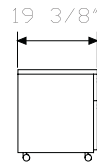

Specification Information

Step 1.
LQ11

Step 2. Front Material
D. painted metal front
A. veneer front **A**
L. laminate front

Step 3. Depth
20 20" deep
24 24" deep

Step 4. Configuration

For 20" deep (20)
BBF box/box/file
BF box/file
FF file/file

For 24" deep (24)
BBF box/box/file
FF file/file

Prices for Steps 1-4.

	BBF	BF	FF
LQ11D. 20	\$724	624	686
24	\$768	—	720
LQ11A. 20	\$958	859	921
24	\$1002	—	954
LQ11L. 20	\$833	718	789
24	\$883	—	828

Step 5. Slides

For box/box/file (BBF)
SR ¾-extension roller slides on box drawer, full-extension ball bearing on file drawer +\$0
SB full-extension ball-bearing +\$50

For box/file (BF)
SR ¾-extension roller slides on box drawer, full-extension ball bearing on file drawer +\$0
SB full-extension ball-bearing +\$25

For file/file (FF)
SB full-extension ball-bearing +\$0

Step 6. Paint/Steel Type
SS smooth paint on smooth steel +\$0
XS textured paint on smooth steel +\$0

Step 7. Surface Finish

For smooth paint on smooth steel (SS)
8Q folkstone grey +\$0
98 studio white +\$0
BU black umber +\$0
CN metallic champagne +\$0
EH metallic bronze +\$0
HF inner tone light +\$0
LT light tone +\$0
LU soft white +\$0
MS metallic silver +\$0
MT medium tone +\$0
SG slate grey +\$0
WL sandstone +\$0

Sand Texture Paint
For textured paint on smooth steel (XS)
91 white +\$0
98 studio white +\$0
BK black +\$0
CL cool grey neutral +\$0
G1 graphite +\$0
WN warm grey neutral +\$0

Step 8. Front Finish

Recut Veneer
For veneer front (A.)
RA light ash **A** +\$0
RK mahogany dark **A** +\$0
RM mahogany **A** +\$0

Wood Veneer		
<i>For veneer front (A.)</i>		
2U	light brown walnut <input type="checkbox"/> A	+\$107
40	dark brown walnut <input type="checkbox"/> A	+\$107
ED	aged cherry <input type="checkbox"/> A	+\$107
EK	medium red walnut <input type="checkbox"/> A	+\$107
EW	medium matte walnut <input type="checkbox"/> A	+\$107
ET	clear on ash <input type="checkbox"/> A	+\$107
EU	oak on ash <input type="checkbox"/> A	+\$107
EV	walnut on ash <input type="checkbox"/> A	+\$107
UL	natural maple <input type="checkbox"/> A	+\$107
UX	walnut on cherry <input type="checkbox"/> A	+\$107

<i>For laminate front (L.)</i>		
76	light brown walnut	+\$0
8Q	folkstone grey	+\$0
91	white	+\$0
98	studio white	+\$0
CL	cool grey neutral	+\$0
HM	natural maple	+\$0
HP	light anigre	+\$0
HX	aged cherry	+\$0
HY	walnut on cherry	+\$0
LA	light ash	+\$0
LBA	clear on ash	+\$0
LBR	phantom ecru	+\$0
LBS	phantom cocoa	+\$0
LBU	medium matte walnut	+\$0
LBV	warm grey teak	+\$0
LBB	oak on ash	+\$0
LBC	walnut on ash	+\$0
LBD	dark brown walnut	+\$0
LBE	medium red walnut	+\$0
LBF	neutral twill	+\$0
LBG	sarum twill	+\$0
LBH	earthen twill	+\$0
LBJ	graphite twill	+\$0
LBK	pewter mesh	+\$0
LBL	steel mesh	+\$0
LBM	crisp linen	+\$0
LBN	classic linen	+\$0
LBP	casual linen	+\$0
LBQ	white twill	+\$0
LU	soft white	+\$0
WL	sandstone	+\$0
WN	warm grey neutral	+\$0
X1	chalk white	+\$0

Step 9. Lock		
KA	keyed alike	-\$10
KC	keyed differently, chrome	+\$0
KD	keyed differently, black	+\$0

Step 10. Pull Finish		
NH	brushed nickel	+\$0
NK	black nickel	+\$0

Step 11. Drawer Interior		
<i>For box/box/file (BBF)</i>		
NN	none	+\$0
2M	drawer divider in box drawers, 2 file converters in file drawer	+\$25
3M	drawer divider in one box drawer, pencil tray in one box drawer, 2 file converters in file drawer	+\$25
C51	storage organizer including hanging file holder bin, utility tray and two containers <input type="checkbox"/> A	+\$120

<i>For box/file (BF)</i>		
NN	none	+\$0
4M	drawer divider in box drawer, 2 file converters in file drawer	+\$20
5M	pencil tray in box drawer, 2 file converters in file drawer	+\$20
C51	storage organizer including hanging file holder bin, utility tray and two containers <input type="checkbox"/> A	+\$120

<i>For file/file (FF)</i>		
NN	none	+\$0
1M	2 file converters in each file drawer	+\$25
C51	storage organizer including hanging file holder bin, utility tray and two containers <input type="checkbox"/> A	+\$120

Step 12. Handle		
HN	no hand grip	+\$0
H1	hand grip only	+\$48

W-Pull Mobile Pedestal

LW110.

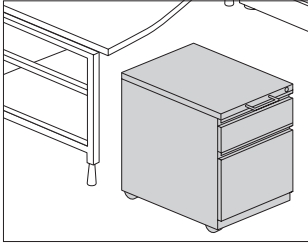

Product Information

Description

This mobile pedestal fits below a hanging or freestanding work surface. It has a smooth-steel case, full-width pulls, and black amber casters. Pedestal can be specified with or without a hand grip. Counterweight is included.

Actual pedestal depth is 19³/₈" or 23¹/₄".

Drawers are available with full-extension or 3/4-extension slides. A drawer divider, utility tray or storage organizer is optional for box drawers. File drawers hold letter-size front-to-back hanging files. File converters are optional for letter-, legal-, and A4-size side-to-side hanging files.

Notes

24"-deep pedestal will not fit below the following products:

- 24"-deep Ethospace® work surface with cable management trough
- Action Office® 60"-wide work surface

Accepts Tu® add-on cushion top (LG890.).

Order optional accessories separately:

- Drawer divider (LG903.)
- File compressor (LG908)
- File converter (LG907)
- File drawer organizer (LG901)
- Pedestal stationery divider (LG905)
- Utility tray (LG906)
- Storage organizer (LG910)

Storage organizer includes a hanging file holder, utility tray (pencil tray) and 2 containers. The storage organizer frame color matches the drawer interior; file holder and containers are 91 white; utility tray is black.

For keyed-alike locks, order lock plugs separately. See Keyed-Alike Information in Appendices.

Dimensions

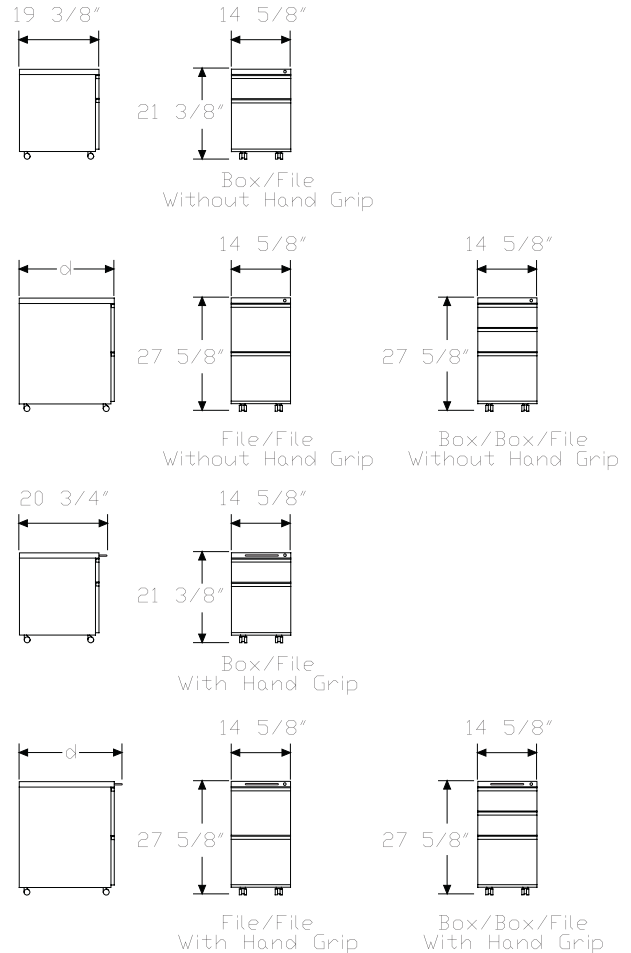

Specification Information

Step 1.

LW110.

Step 2. Depth

20	20" deep
24	24" deep

Step 3. Configuration

For 20" deep (20)

BBF	box/box/file
BF	box/file
FF	file/file

For 24" deep (24)

BBF	box/box/file
FF	file/file

Prices for Steps 1-3.

	BBF	BF	FF
LW110. 20	\$618	520	562
24	\$623	—	570

Step 4. Slides

For box/box/file (BBF)

SR	3/4-extension roller slides on box drawer, full-extension ball bearing on file drawer	+\$0
SB	full-extension ball-bearing	+\$50

For box/file (BF)

SR	3/4-extension roller slides on box drawer, full-extension ball bearing on file drawer	+\$0
SB	full-extension ball-bearing	+\$25

For file/file (FF)

SB	full-extension ball-bearing	+\$0
-----------	-----------------------------	------

Step 5. Paint/Steel Type

SS	smooth paint on smooth steel	+\$0
XS	textured paint on smooth steel	+\$0

Step 6. Surface Finish

For smooth paint on smooth steel (SS)

8Q	folkstone grey	+\$0
98	studio white	+\$0
BU	black umber	+\$0
CN	metallic champagne	+\$0
EH	metallic bronze	+\$0
HF	inner tone light	+\$0
LT	light tone	+\$0
LU	soft white	+\$0
MS	metallic silver	+\$0
MT	medium tone	+\$0
SG	slate grey	+\$0
WL	sandstone	+\$0

Sand Texture Paint

For textured paint on smooth steel (XS)

91	white	+\$0
98	studio white	+\$0
BK	black	+\$0
CL	cool grey neutral	+\$0
G1	graphite	+\$0
WN	warm grey neutral	+\$0

Step 7. Lock

KA	keyed alike	-\$10
KC	keyed differently, chrome	+\$0
KD	keyed differently, black	+\$0

Step 8. Drawer Interior

For box/box/file (BBF)

NN	none	+\$0
2M	drawer divider in box drawers, 2 file converters in file drawer	+\$25
3M	drawer divider in one box drawer, pencil tray in one box drawer, 2 file converters in file drawer	+\$25
C51	storage organizer including hanging file holder bin, utility tray and two containers A	+\$120

W-Pull Mobile Pedestal *continued*

For box/file (BF)

NN	none	+\$0
4M	drawer divider in box drawer, 2 file converters in file drawer	+\$20
5M	pencil tray in box drawer, 2 file converters in file drawer	+\$20
C51	storage organizer including hanging file holder bin, utility tray and two containers <input type="checkbox"/> A	+\$120

For file/file (FF)

NN	none	+\$0
1M	2 file converters in each file drawer	+\$25
C51	storage organizer including hanging file holder bin, utility tray and two containers <input type="checkbox"/> A	+\$120

Step 9. Handle

HN	no hand grip	+\$0
H1	hand grip only	+\$48

V-Pull Mobile Pedestal

LV110.

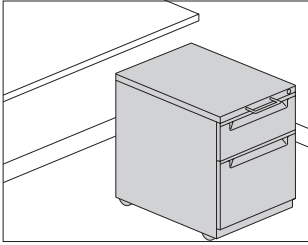

Tu® Metal Storage

Product Information

Description

This mobile pedestal fits below a hanging or freestanding work surface. It has a smooth-steel case, full-width recessed pulls, and black rubber casters. Pedestal can be specified with or without a hand grip.

Counterweight is included.

Actual pedestal depth is $19\frac{3}{8}$ " or $23\frac{3}{4}$ ".

Drawers are available with full-extension or $\frac{3}{4}$ -extension slides. A drawer divider, utility tray or storage organizer is optional for box drawers. File drawers hold letter-size front-to-back hanging files. File converters are optional for letter-, legal-, and A4-size side-to-side hanging files.

Notes

24"-deep pedestal will not fit below the following products:

- 24"-deep Ethospace® work surface with cable management trough
- Action Office® 60"-wide work surface
- Prospects® 60"-wide work surface

Accepts Tu® add-on cushion top (LG890).

Order optional accessories separately:

- Drawer divider (LG903)
- File compressor (LG908)
- File converter (LG907)
- File drawer organizer (LG901)
- Pedestal stationery divider (LG905)
- Utility tray (LG906)
- Storage organizer (LG910)

Storage organizer includes a hanging file holder, utility tray (pencil tray) and 2 containers. The storage organizer frame color matches the drawer interior; file holder and containers are 91 white; utility tray is black.

For keyed-alike locks, order lock plugs separately. See Keyed-Alike Information in Appendices.

Dimensions

19 3/8"

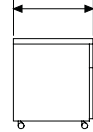

14 5/8"

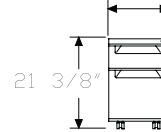

21 3/8"

Box/File
Without Hand Grip



14 5/8"

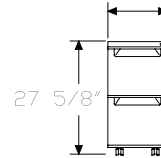

27 5/8"

File/File
Without Hand Grip

14 5/8"

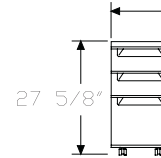

27 5/8"

Box/Box/File
Without Hand Grip

20 3/4"

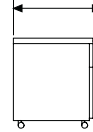

14 5/8"

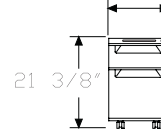

21 3/8"

Box/File
With Hand Grip



14 5/8"

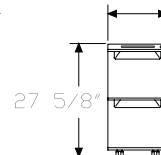

27 5/8"

File/File
With Hand Grip

14 5/8"

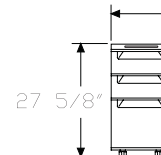

27 5/8"

Box/Box/File
With Hand Grip

Specification Information

Step 1.

LV110.

Step 2. Depth

20	20" deep
24	24" deep

Step 3. Configuration

For 20" deep (20)

BBF	box/box/file
BF	box/file
FF	file/file

For 24" deep (24)

BBF	box/box/file
FF	file/file

Prices for Steps 1-3.

	BBF	BF	FF
LV110. 20	\$637	537	578
24	\$642	—	585

Step 4. Slides

For box/box/file (BBF)

SR	¾-extension roller slides on box drawer, full-extension ball bearing on file drawer	+\$0
SB	full-extension ball-bearing	+\$50

For box/file (BF)

SR	¾-extension roller slides on box drawer, full-extension ball bearing on file drawer	+\$0
SB	full-extension ball-bearing	+\$25

For file/file (FF)

SB	full-extension ball-bearing	+\$0
-----------	-----------------------------	------

Step 5. Paint/Steel Type

SS	smooth paint on smooth steel	+\$0
XS	textured paint on smooth steel	+\$0

Step 6. Surface Finish

For smooth paint on smooth steel (SS)

8Q	folkstone grey	+\$0
98	studio white	+\$0
BU	black umber	+\$0
CN	metallic champagne	+\$0
EH	metallic bronze	+\$0
HF	inner tone light	+\$0
LT	light tone	+\$0
LU	soft white	+\$0
MS	metallic silver	+\$0
MT	medium tone	+\$0
SG	slate grey	+\$0
WL	sandstone	+\$0

Sand Texture Paint

For textured paint on smooth steel (XS)

91	white	+\$0
98	studio white	+\$0
BK	black	+\$0
CL	cool grey neutral	+\$0
G1	graphite	+\$0
WN	warm grey neutral	+\$0

Step 7. Lock

KA	keyed alike	-\$10
KC	keyed differently, chrome	+\$0
KD	keyed differently, black	+\$0

Step 8. Drawer Interior

For box/box/file (BBF)

NN	none	+\$0
2M	drawer divider in box drawers, 2 file converters in file drawer	+\$25
3M	drawer divider in one box drawer, pencil tray in one box drawer, 2 file converters in file drawer	+\$25
C51	storage organizer including hanging file holder bin, utility tray and two containers A	+\$120

V-Pull Mobile Pedestal *continued*

Tu® Metal Storage

For box/file (BF)

NN	none	+\$0
4M	drawer divider in box drawer, 2 file converters in file drawer	+\$20
5M	pencil tray in box drawer, 2 file converters in file drawer	+\$20
C51	storage organizer including hanging file holder bin, utility tray and two containers A	+\$120

For file/file (FF)

NN	none	+\$0
1M	2 file converters in each file drawer	+\$25
C51	storage organizer including hanging file holder bin, utility tray and two containers A	+\$120

Step 9. Handle

HN	no hand grip	+\$0
H1	hand grip only	+\$48

Bar Pull Surface-Attached Pedestal

LK14A.
LK14D.

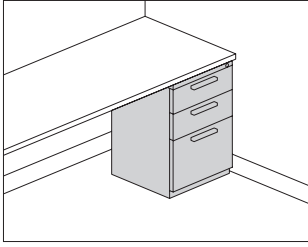

Product Information

Description

This pedestal attaches under a work surface on the left or right side to provide support and eliminates the need for a cantilever. It has a painted or veneer front, smooth-steel case, applied metal bar pulls, and 1" leveling glides. Attachment hardware is included.

Actual pedestal height is 27¹/₄". Height with squared-edge laminate or veneer work surface is 28¹/₂". Height with squared- or eased-edge Formcoat™ work surface is 28³/₄". Actual pedestal depth is 19³/₈", 22⁷/₈", or 28⁷/₈". Pedestal does not work with thin-edge work surfaces.

For freestanding applications, the 24"-deep pedestal depth matches a 24"-deep Canvas or Ethospace® work surface. The 30"-deep pedestal depth matches a 30"-deep Canvas or Ethospace work surface.

Box drawers are available with full-extension or 3/4"-extension slides.

File drawers have full-extension slides. A drawer divider, utility tray or storage organizer is optional for box drawers. File drawers hold letter-size front-to-back hanging files. File converters are optional for letter-, legal-, and A4-size side-to-side hanging files.

Notes

Base on 27¹/₄"-high (raised height) unit (2F) aligns with base on Tu® storage towers.

For full extension slides on box drawers, specify option (SB).

Grain direction is vertical for veneer-front pedestals.

To add file converters, drawer divider, pencil tray, or storage organizer to drawer interiors, specify drawer interior option (1M), (2M), (3M) or (C51).

Order optional accessories separately:

- Drawer divider (LG903.)
- File compressor (LG908)
- File converter (LG907)
- File drawer organizer (LG901)
- Pedestal stationery divider (LG905)
- Utility tray (LG906)
- Storage organizer (LG910)

Storage organizer includes a hanging file holder, utility tray (pencil tray) and 2 containers. Storage organizer frame color matches drawer interior; file holder and containers are 91 white; utility tray is black.

For keyed-alike locks, order lock plugs separately. See Keyed-Alike Information in Appendices.

Dimensions

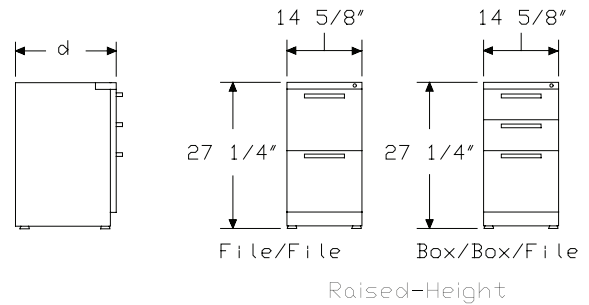

Bar Pull Surface-Attached Pedestal *continued*

Specification Information

Step 1.

LK14

Step 2. Front Material

- D.** painted metal front
- A.** veneer front A

Step 3. Depth

- 20** 20" deep
- 24** 24" deep
- 28** 28" deep

Step 4. Configuration

- BBF** box/box/file
- FF** file/file

Prices for Steps 1-4.

	BBF	FF
LK14D. 20	\$599	615
24	\$634	651
28	\$700	717
LK14A. 20	\$829	847
24	\$867	886
28	\$933	951

Step 5. Slides

For box/box/file (BBF)

- SR** ¾-extension roller slides on box drawer, full-extension ball bearing on file drawer +\$0
- SB** full-extension ball-bearing +\$50

For file/file (FF)

- SB** full-extension ball-bearing +\$0

Step 6. Paint/Steel Type

- SS** smooth paint on smooth steel +\$0
- XS** textured paint on smooth steel +\$0

Step 7. Surface Finish

For smooth paint on smooth steel (SS)

- 8Q** folkstone grey +\$0
- 98** studio white +\$0
- BU** black umber +\$0
- CN** metallic champagne +\$0
- EH** metallic bronze +\$0
- HF** inner tone light +\$0
- LT** light tone +\$0
- LU** soft white +\$0
- MS** metallic silver +\$0
- MT** medium tone +\$0
- SG** slate grey +\$0
- WL** sandstone +\$0

Sand Texture Paint

For textured paint on smooth steel (XS)

- 91** white +\$0
- 98** studio white +\$0
- BK** black +\$0
- CL** cool grey neutral +\$0
- G1** graphite +\$0
- WN** warm grey neutral +\$0

Step 8. Front Finish

For veneer front (A.)

Recut Veneer

- RA** light ash A +\$0
- RK** mahogany dark A +\$0
- RM** mahogany A +\$0
- 2U** light brown walnut A +\$107
- 40** dark brown walnut A +\$107
- ED** aged cherry A +\$107
- EK** medium red walnut A +\$107
- EW** medium matte walnut A +\$107
- ET** clear on ash A +\$107
- EV** walnut on ash A +\$107
- UL** natural maple A +\$107
- UX** walnut on cherry A +\$107

Step 9. Lock

- KA** keyed alike -\$10
- KC** keyed differently, chrome +\$0
- KD** keyed differently, black +\$0

Bar Pull Surface-Attached Pedestal *continued*

Step 10. Pull Finish

Metallic Paint		
CN	metallic champagne	+\$0
MS	metallic silver	+\$0
Sand Texture Paint		
79	green apple	+\$15
BK	black	+\$0
MY3	yellow oxide	+\$15
RO	red	+\$15
TRQ	turquoise	+\$15
Smooth Paint		
8Q	folkstone grey	+\$0
91	white	+\$0
98	studio white	+\$0
G1	graphite	+\$0
WL	sandstone	+\$0
XX	no pull	+\$0

Step 11. Base Height		
2F	27 ¹ / ₄ " high (raised height)	+\$0

Step 12. Drawer Interior

For box/box/file (BBF)		
NN	none	+\$0
2M	drawer divider in box drawers, 2 file converters in file drawer	+\$25
3M	drawer divider in one box drawer, pencil tray in one box drawer, 2 file converters in file drawer	+\$25
C51	storage organizer including hanging file holder bin, utility tray and two containers A	+\$120
For file/file (FF)		
NN	none	+\$0
1M	2 file converters in each file drawer	+\$25
C51	storage organizer including hanging file holder bin, utility tray and two containers A	+\$120

Arc Pull Surface-Attached Pedestal

LQ14A.
LQ14D.

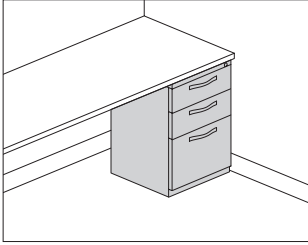

Tu® Metal Storage

Product Information

Description

This pedestal attaches under a work surface on the left or right side to provide support and eliminates the need for a cantilever. It has a painted or veneer front, smooth-steel case, applied metal arc pulls, and 1" leveling glides. Attachment hardware is included.

Actual pedestal height is 27¹/₄". Height with squared-edge laminate or veneer work surface is 28¹/₂". Height with squared- or eased-edge Formcoat™ work surface is 28³/₄". Actual pedestal depth is 19³/₈", 22⁷/₈", or 28⁷/₈". Pedestal does not work with thin-edge work surfaces

For freestanding applications, the 24"-deep pedestal depth matches a 24"-deep Canvas or Ethospace® work surface. The 30"-deep pedestal depth matches a 30"-deep Canvas or Ethospace work surface.

Box drawers are available with full-extension or 3/4"-extension slides. File drawers have full-extension slides. A drawer divider, utility tray or storage organizer is optional for box drawers. File drawers hold letter-size front-to-back hanging files. File converters are optional for letter-, legal-, and A4-size side-to-side hanging files.

Notes

Pull design conforms to guidelines of Americans with Disabilities Act (ADA).

Base on 27¹/₄"-high (raised height) unit (2F) aligns with base on Tu® storage towers.

For full extension slides on box drawers, specify option (SB).

Grain direction is vertical for veneer-front pedestals.

To add file converters, drawer divider, pencil tray, or storage organizer to drawer interiors, specify drawer interior option (1M), (2M), (3M) or (C51).

Order optional accessories separately:

- Drawer divider (LG903.)
- File compressor (LG908)
- File converter (LG907)
- File drawer organizer (LG901)
- Pedestal stationery divider (LG905)
- Utility tray (LG906)
- Storage organizer (LG910)

Storage organizer includes a hanging file holder, utility tray (pencil tray) and 2 containers. The storage organizer frame color matches the drawer interior; file holder and containers are 91 white; utility tray is black.

For keyed-alike locks, order lock plugs separately. See Keyed-Alike Information in Appendices.

Dimensions

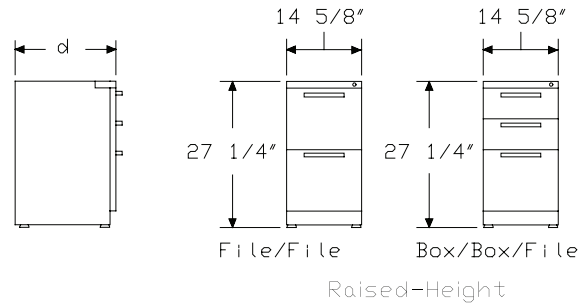

Arc Pull Surface-Attached Pedestal *continued*

Specification Information

Step 1.

LQ14

Step 2. Front Material

- D.** painted metal front
- A.** veneer front A

Step 3. Depth

- 20** 20" deep
- 24** 24" deep
- 28** 28" deep

Step 4. Configuration

- BBF** box/box/file
- FF** file/file

Prices for Steps 1-4.

	BBF	FF
LQ14D. 20	\$599	615
24	\$634	651
28	\$700	717
LQ14A. 20	\$829	847
24	\$867	886
28	\$933	951

Step 5. Slides

For box/box/file (BBF)

- SR** ¾-extension roller slides on box drawer, full-extension ball bearing on file drawer + \$0
- SB** full-extension ball-bearing + \$50

For file/file (FF)

- SB** full-extension ball-bearing + \$0

Step 6. Paint/Steel Type

- SS** smooth paint on smooth steel + \$0
- XS** textured paint on smooth steel + \$0

Step 7. Surface Finish

For smooth paint on smooth steel (SS)

- 8Q** folkstone grey + \$0
- 98** studio white + \$0
- BU** black umber + \$0
- CN** metallic champagne + \$0
- EH** metallic bronze + \$0
- HF** inner tone light + \$0
- LT** light tone + \$0
- LU** soft white + \$0
- MS** metallic silver + \$0
- MT** medium tone + \$0
- SG** slate grey + \$0
- WL** sandstone + \$0

Sand Texture Paint

For textured paint on smooth steel (XS)

- 91** white + \$0
- 98** studio white + \$0
- BK** black + \$0
- CL** cool grey neutral + \$0
- G1** graphite + \$0
- WN** warm grey neutral + \$0

Step 8. Front Finish

For veneer front (A.)

Recut Veneer

- RA** light ash A + \$0
- RK** mahogany dark A + \$0
- RM** mahogany A + \$0

Wood Veneer

- 2U** light brown walnut A + \$107
- 40** dark brown walnut A + \$107
- ED** aged cherry A + \$107
- EK** medium red walnut A + \$107
- EW** medium matte walnut A + \$107
- ET** clear on ash A + \$107
- EU** oak on ash A + \$107
- EV** walnut on ash A + \$107
- UL** natural maple A + \$107
- UX** walnut on cherry A + \$107

Arc Pull Surface-Attached Pedestal *continued*

Tu® Metal Storage

Step 9. Lock

KA	keyed alike	-\$10
KC	keyed differently, chrome	+\$0
KD	keyed differently, black	+\$0

Step 10. Pull Finish

NH	brushed nickel	+\$0
NK	black nickel	+\$0

Step 11. Base Height

2F	27 ¹ / ₄ " high (raised height)	+\$0
-----------	-------------------------------------------------------	------

Step 12. Drawer Interior

For box/box/file (BBF)

NN	none	+\$0
2M	drawer divider in box drawers, 2 file converters in file drawer	+\$25
3M	drawer divider in one box drawer, pencil tray in one box drawer, 2 file converters in file drawer	+\$25
C51	storage organizer including hanging file holder bin, utility tray and two containers <input type="checkbox"/>	+\$120

For file/file (FF)

NN	none	+\$0
1M	2 file converters in each file drawer	+\$25
C51	storage organizer including hanging file holder bin, utility tray and two containers <input type="checkbox"/>	+\$120

W-Pull Surface-Attached Pedestal LW140.

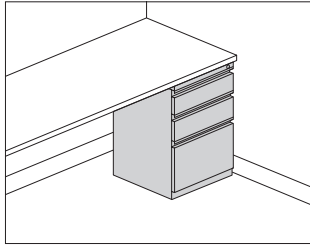

Product Information

Description

This pedestal attaches under a work surface on the left or right side to provide support and eliminates the need for a cantilever. It has a painted metal front, smooth-steel case, full-width recessed pulls, and 1" leveling glides. Attachment hardware is included.

Actual pedestal height is 27¹/₄". Height with squared-edge laminate or veneer work surface is 28¹/₂". Height with squared- or eased-edge Formcoat™ work surface is 28³/₄". Actual pedestal depth is 19³/₈", 22⁷/₈", or 28⁷/₈". Pedestal does not work with thin-edge work surfaces.

For freestanding applications, the 24"-deep pedestal depth matches a 24"-deep Canvas or Ethospace® work surface. The 30"-deep pedestal depth matches a 30"-deep Canvas or Ethospace work surface.

Box drawers are available with full-extension or 3/4"-extension slides.

File drawers have full-extension slides. A drawer divider, utility tray or storage organizer is optional for box drawers. File drawers hold letter-size front-to-back hanging files. File converters are optional for letter-, legal-, and A4-size side-to-side hanging files.

Notes

Base on 27¹/₄"-high (raised height) unit (2F) aligns with base on Tu® storage towers.

For full extension slides on box drawers, specify option (SB).

To add file converters, drawer divider, pencil tray, or storage organizer to drawer interiors, specify drawer interior option (1M), (2M), (3M) or (C51).

Order optional accessories separately:

- Drawer divider (LG903.)
- File compressor (LG908)
- File converter (LG907)
- File drawer organizer (LG901)
- Pedestal stationery divider (LG905)
- Utility tray (LG906)
- Storage organizer (LG910)

Storage organizer includes a hanging file holder, utility tray (pencil tray) and 2 containers. The storage organizer frame color matches the drawer interior; file holder and containers are 91 white; utility tray is black.

For keyed-alike locks, order lock plugs separately. See Keyed-Alike Information in Appendices.

Dimensions

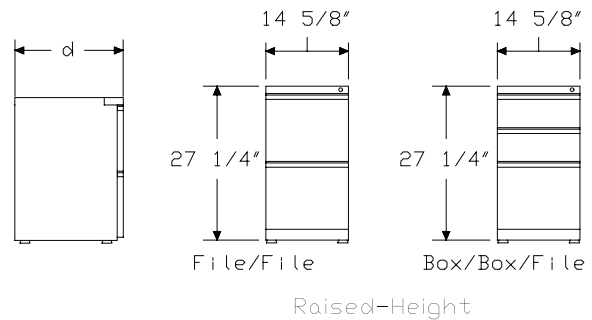

W-Pull Surface-Attached Pedestal

continued

Tu® Metal Storage

Specification Information

Step 1.

LW140.

Step 2. Depth

20	20" deep
24	24" deep
28	28" deep

Step 3. Configuration

BBF	box/box/file
FF	file/file

Prices for Steps 1-3.

	BBF	FF
LW140. 20	\$528	483
24	\$542	495
28	\$633	582

Step 4. Slides

For box/box/file (BBF)

SR	3/4"-extension roller slides on box drawer, full-extension ball bearing on file drawer	+\$0
SB	full-extension ball-bearing	+\$50

For file/file (FF)

SB	full-extension ball-bearing	+\$0
-----------	-----------------------------	------

Step 5. Paint/Steel Type

SS	smooth paint on smooth steel	+\$0
XS	textured paint on smooth steel	+\$0

Step 6. Surface Finish

For smooth paint on smooth steel (SS)

8Q	folkstone grey	+\$0
98	studio white	+\$0
BU	black umber	+\$0
CN	metallic champagne	+\$0
EH	metallic bronze	+\$0
HF	inner tone light	+\$0
LT	light tone	+\$0
LU	soft white	+\$0
MS	metallic silver	+\$0
MT	medium tone	+\$0
SG	slate grey	+\$0
WL	sandstone	+\$0

Sand Texture Paint

For textured paint on smooth steel (XS)

91	white	+\$0
98	studio white	+\$0
BK	black	+\$0
CL	cool grey neutral	+\$0
G1	graphite	+\$0
WN	warm grey neutral	+\$0

Step 7. Lock

KA	keyed alike	-\$10
KD	keyed differently, black	+\$0
KC	keyed differently, chrome	+\$0

Step 8. Base Height

2F	27 1/4" high (raised height)	+\$0
-----------	------------------------------	------

Step 9. Drawer Interior

For 20" deep (20) or 24" deep (24) with box/box/file (BBF)

NN	none	+\$0
2M	drawer divider in box drawers, 2 file converters in file drawer	+\$25
3M	drawer divider in one box drawer, pencil tray in one box drawer, 2 file converters in file drawer	+\$25
C51	storage organizer including hanging file holder bin, utility tray and two containers A	+\$120

W-Pull Surface-Attached Pedestal

continued

For 28" deep (28) with box/box/file (BBF)

NN	none	+\$0
2M	drawer divider in box drawers, 2 file converters in file drawer	+\$25
3M	drawer divider in one box drawer, pencil tray in one box drawer, 2 file converters in file drawer	+\$25

For 20" deep (20) or 24" deep (24) with file/file (FF)

NN	none	+\$0
1M	2 file converters in each file drawer	+\$25
C51	storage organizer including hanging file holder bin, utility tray and two containers A	+\$120

For 28" deep (28) with file/file (FF)

NN	none	+\$0
1M	2 file converters in each file drawer	+\$25

V-Pull Surface-Attached Pedestal LV140.

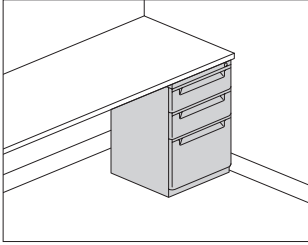

Tu® Metal Storage

Product Information

Description

This pedestal attaches under a work surface on the left or right side to provide support and eliminates the need for a cantilever. It has a painted metal front, smooth-steel case, full-width recessed pulls, and 1" leveling glides. Attachment hardware is included.

Actual pedestal height is 27¹/₄". Height with squared-edge laminate or veneer work surface is 28¹/₂". Height with squared- or eased-edge Formcoat™ work surface is 28¹/₄". Actual pedestal depth is 19³/₈", 22⁷/₈", or 28⁷/₈". Pedestal does not work with thin-edge work surfaces

For freestanding applications, the 24"-deep pedestal depth matches a 24"-deep Canvas or Ethospace® work surface. The 30"-deep pedestal depth matches a 30"-deep Canvas or Ethospace work surface.

Box drawers are available with full-extension or 3/4-extension slides.

File drawers have full-extension slides. A drawer divider, utility tray or storage organizer is optional for box drawers. File drawers hold letter-size front-to-back hanging files. File converters are optional for letter-, legal-, and A4-size side-to-side hanging files.

Notes

Base on 27¹/₄"-high (raised height) unit (2F) aligns with base on Tu® storage towers.

For full extension slides on box drawers, specify option (SB).

To add file converters, drawer divider, pencil tray, or storage organizer to drawer interiors, specify drawer interior option (1M), (2M), (3M) or (C51).

Order optional accessories separately:

- Drawer divider (LG903.)
- File compressor (LG908)
- File converter (LG907)
- File drawer organizer (LG901)
- Pedestal stationery divider (LG905)
- Utility tray (LG906)
- Storage organizer (LG910)

Storage organizer includes a hanging file holder, utility tray (pencil tray) and 2 containers. The storage organizer frame color matches the drawer interior; file holder and containers are 91 white; utility tray is black.

For keyed-alike locks, order lock plugs separately. See Keyed-Alike Information in Appendices.

Dimensions

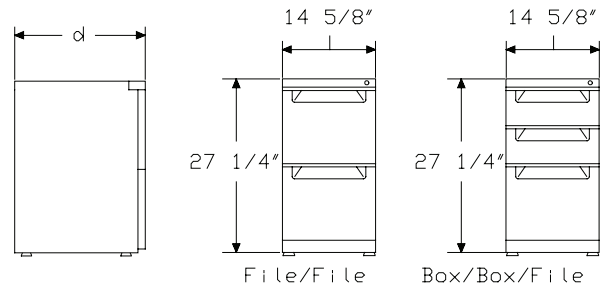

Raised-Height

V-Pull Surface-Attached Pedestal

continued

Specification Information

Step 1.

LV140.

Step 2. Depth

20	20" deep
24	24" deep
28	28" deep

Step 3. Configuration

BBF	box/box/file
FF	file/file

Prices for Steps 1-3.

	BBF	FF
LV140. 20	\$540	496
24	\$558	508
28	\$628	575

Step 4. Slides

For box/box/file (BBF)

SR	¾-extension roller slides on box drawer, full-extension ball bearing on file drawer	+\$0
SB	full-extension ball-bearing	+\$50

For file/file (FF)

SB	full-extension ball-bearing	+\$0
-----------	-----------------------------	------

Step 5. Paint/Steel Type

SS	smooth paint on smooth steel	+\$0
XS	textured paint on smooth steel	+\$0

Step 6. Surface Finish

For smooth paint on smooth steel (SS)

8Q	folkstone grey	+\$0
98	studio white	+\$0
BU	black umber	+\$0
CN	metallic champagne	+\$0
EH	metallic bronze	+\$0
HF	inner tone light	+\$0
LT	light tone	+\$0
LU	soft white	+\$0
MS	metallic silver	+\$0
MT	medium tone	+\$0
SG	slate grey	+\$0
WL	sandstone	+\$0

Sand Texture Paint

For textured paint on smooth steel (XS)

91	white	+\$0
98	studio white	+\$0
BK	black	+\$0
CL	cool grey neutral	+\$0
G1	graphite	+\$0
WN	warm grey neutral	+\$0

Step 7. Lock

KA	keyed alike	-\$10
KC	keyed differently, chrome	+\$0
KD	keyed differently, black	+\$0

Step 8. Base Height

2F	27¼" high (raised height)	+\$0
-----------	---------------------------	------

Step 9. Drawer Interior

For 20" deep (20) or 24" deep (24) with box/box/file (BBF)

NN	none	+\$0
2M	drawer divider in box drawers, 2 file converters in drawer	+\$25
3M	drawer divider in one box drawer, pencil tray in one box drawer, 2 file converters in file drawer	+\$25
C51	storage organizer including hanging file holder bin, utility tray and two containers A	+\$120

V-Pull Surface-Attached Pedestal

continued

Tu® Metal Storage

For 28" deep (28) with box/box/file (BBF)

NN	none	+\$0
2M	drawer divider in box drawers, 2 file converters in file drawer	+\$25
3M	drawer divider in one box drawer, pencil tray in one box drawer, 2 file converters in file drawer	+\$25

For 20" deep (20) or 24" deep (24) with file/file (FF)

NN	none	+\$0
1M	2 file converters in each file drawer	+\$25
C51	storage organizer including hanging file holder bin, utility tray and two containers A	+\$120

For 28" deep (28) with file/file (FF)

NN	none	+\$0
1M	2 file converters in each file drawer	+\$25

Bar Pull Support Pedestal

LK15A.
LK15D.

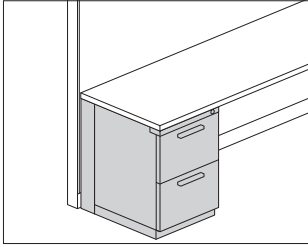

Product Information

Description

This pedestal attaches to both a work surface and a panel or frame at the end of a run or mid-run to provide support. It eliminates the need for a return panel/frame and connector or a work surface support panel. It has a painted or veneer front, smooth-steel case, applied metal bar pulls, and 1 3/4" leveling glides. The pedestal attaches under a work surface on the left or right side. Attachment hardware and support bracket are included.

The actual pedestal depth is 19 3/8", 23 1/4", or 27 3/4". A 20"-deep pedestal supports a 24"-deep work surface. A 24"-deep pedestal supports a 30"-deep Ethospace® work surface with a cable management trough. A 28"-deep pedestal supports a 30"-deep work surface.

Box drawers are available with full-extension or 3/4"-extension slides. File drawers have full-extension slides and hold letter-size front-to-back hanging files.

Notes

To add drawer divider, pencil tray, and file converters to drawer interiors, specify option (2M) or (3M).

For full extension slides on box drawers, specify option (SB).

Grain direction is vertical for veneer-front pedestals.

Order optional accessories separately:

- Drawer divider (LG903.)
- File compressor (LG908)
- File converter (LG907)
- File drawer organizer (LG901)
- Pedestal stationery divider (LG905)
- Utility tray (LG906)
- Storage organizer (LG910)

Storage organizer includes a hanging file holder, utility tray (pencil tray) and 2 containers. Storage organizer frame color matches drawer interior; file holder and containers are 91 white; utility tray is black.

For keyed-alike locks, order lock plugs separately. See Keyed-Alike Information in Appendices.

Dimensions

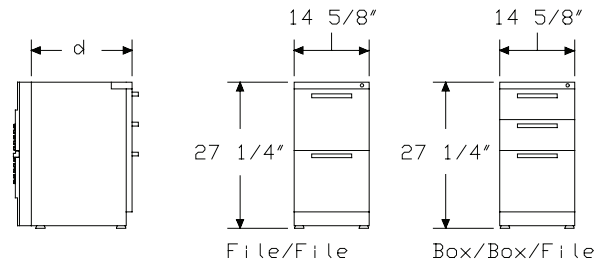

Specification Information		
Step 1.		
LK15		
Step 2. Front Material		
D.	painting metal front	
A.	veneer front <input type="checkbox"/>	
Step 3. Depth		
20	20" deep	
24	24" deep	
28	28" deep	
Step 4. Configuration		
BBF	box/box/file	
FF	file/file	
Prices for Steps 1-4.		
		BBF FF
LK15D. 20		\$726 700
24		\$828 789
28		\$929 882
LK15A. 20		\$961 933
24		\$1067 1025
28		\$1168 1119
Step 5. Slides		
<i>For box/box/file (BBF)</i>		
SR	3/4"-extension roller slides on box drawer, full-extension ball bearing on file drawer	+\$0
SB	full-extension ball-bearing	+\$50
<i>For file/file (FF)</i>		
SB	full-extension ball-bearing	+\$0
Step 6. Paint/Steel Type		
SS	smooth paint on smooth steel	+\$0
XS	textured paint on smooth steel	+\$0

Step 7. Surface Finish		
<i>For smooth paint on smooth steel (SS)</i>		
8Q	folkstone grey	+\$0
98	studio white	+\$0
BU	black umber	+\$0
CN	metallic champagne	+\$0
EH	metallic bronze	+\$0
HF	inner tone light	+\$0
LT	light tone	+\$0
LU	soft white	+\$0
MS	metallic silver	+\$0
MT	medium tone	+\$0
SG	slate grey	+\$0
WL	sandstone	+\$0
Sand Texture Paint		
<i>For textured paint on smooth steel (XS)</i>		
91	white	+\$0
98	studio white	+\$0
BK	black	+\$0
CL	cool grey neutral	+\$0
G1	graphite	+\$0
WN	warm grey neutral	+\$0
Step 8. Attachment Bracket		
1A	for Action Office® Series 1 and 2 radiused-edge work surface	+\$0
2A	for Action Office® Series 1 and 2 squared-edge work surface	+\$0
E1	for Ethospace® System	+\$0
F8	for Canvas Office Landscape®	+\$0
Step 9. Front Finish		
<i>For veneer front (A.)</i>		
Recut Veneer		
RA	light ash <input type="checkbox"/>	+\$0
RK	mahogany dark <input type="checkbox"/>	+\$0
RM	mahogany <input type="checkbox"/>	+\$0

Wood Veneer		
2U	light brown walnut <input type="checkbox"/> A	+\$107
40	dark brown walnut <input type="checkbox"/> A	+\$107
ED	aged cherry <input type="checkbox"/> A	+\$107
EK	medium red walnut <input type="checkbox"/> A	+\$107
EW	medium matte walnut <input type="checkbox"/> A	+\$107
ET	clear on ash <input type="checkbox"/> A	+\$107
EV	walnut on ash <input type="checkbox"/> A	+\$107
UL	natural maple <input type="checkbox"/> A	+\$107
UX	walnut on cherry <input type="checkbox"/> A	+\$107

Step 10. Lock		
KA	keyed alike	-\$10
KC	keyed differently, chrome	+\$0
KD	keyed differently, black	+\$0

Step 11. Pull Finish		
Metallic Paint		
CN	metallic champagne	+\$0
MS	metallic silver	+\$0

Sand Texture Paint		
79	green apple	+\$15
BK	black	+\$0
MY3	yellow oxide	+\$15
RO	red	+\$15
TRQ	turquoise	+\$15

Smooth Paint		
8Q	folkstone grey	+\$0
91	white	+\$0
98	studio white	+\$0
G1	graphite	+\$0
WL	sandstone	+\$0
XX	no pull	+\$0

Step 12. Drawer Interior		
<i>For box/box/file (BBF)</i>		
NN	none	+\$0
2M	drawer divider in box drawers, 2 file converters in file drawer	+\$25
3M	drawer divider in one box drawer, pencil tray in one box drawer, 2 file converters in file drawer	+\$25
C51	storage organizer including hanging file holder bin, utility tray and two containers <input type="checkbox"/> A	+\$120

<i>For file/file (FF)</i>		
NN	none	+\$0
1M	2 file converters in each file drawer	+\$25
C51	storage organizer including hanging file holder bin, utility tray and two containers <input type="checkbox"/> A	+\$120

Arc Pull Support Pedestal

LQ15A.
LQ15D.

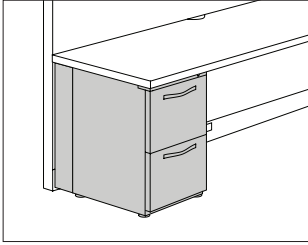

Tu® Metal Storage

Product Information

Description

This pedestal attaches to both a work surface and a panel or frame at the end of a run or mid-run to provide support. It eliminates the need for a return panel/frame and connector or a work surface support panel. It has a painted or veneer front, smooth-steel case, applied metal arc pulls, and 1 3/4" leveling glides. The pedestal attaches under a work surface on the left or right side. Attachment hardware and support bracket are included.

The actual pedestal depth is 19 3/8", 23 3/4", or 27 3/4". A 20"-deep pedestal supports a 24"-deep work surface. A 24"-deep pedestal supports a 30"-deep Ethospace® work surface with a cable management trough. A 28"-deep pedestal supports a 30"-deep work surface.

Box drawers are available with full-extension or 3/4"-extension slides. File drawers have full-extension slides and hold letter-size front-to-back hanging files.

Notes

Pull design conforms to guidelines of Americans with Disabilities Act (ADA).

To add drawer divider, pencil tray, file converters and storage organizer to drawer interiors, specify option (1M), (2M), (3M) or (C51).

For full extension slides on box drawers, specify option (SB).

Grain direction is vertical for veneer-front pedestals.

Order optional accessories separately:

- Drawer divider (LG903.)
- File compressor (LG908)
- File converter (LG907)
- File drawer organizer (LG901)
- Pedestal stationery divider (LG905)
- Utility tray (LG906)
- Storage organizer (LG910)

Storage organizer includes a hanging file holder, utility tray (pencil tray) and 2 containers. The storage organizer frame color matches the drawer interior; file holder and containers are 91 white; utility tray is black.

For keyed-alike locks, order lock plugs separately. See Keyed-Alike Information in Appendices.

Dimensions

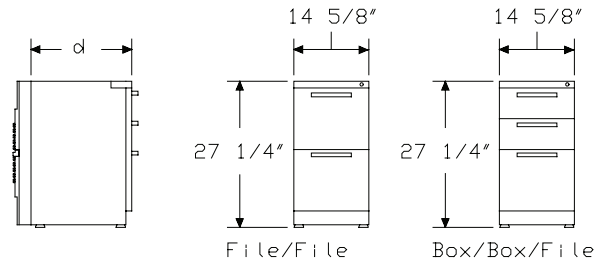

Specification Information

Step 1.

LQ15

Step 2. Front Material

- D.** painted metal front
- A.** veneer front A

Step 3. Depth

- 20** 20" deep
- 24** 24" deep
- 28** 28" deep

Step 4. Configuration

- BBF** box/box/file
- FF** file/file

Prices for Steps 1-4.

	BBF	FF
LQ15D. 20	\$726	700
24	\$828	789
28	\$929	882
LQ15A. 20	\$961	933
24	\$1067	1025
28	\$1168	1119

Step 5. Slides

For box/box/file (BBF)

- SR** ¾-extension roller slides on box drawer, full-extension ball bearing on file drawer + \$0
- SB** full-extension ball-bearing + \$50

For file/file (FF)

- SB** full-extension ball-bearing + \$0

Step 6. Paint/Steel Type

- SS** smooth paint on smooth steel + \$0
- XS** textured paint on smooth steel + \$0

Step 7. Surface Finish

For smooth paint on smooth steel (SS)

- 8Q** folkstone grey + \$0
- 98** studio white + \$0
- BU** black umber + \$0
- CN** metallic champagne + \$0
- EH** metallic bronze + \$0
- HF** inner tone light + \$0
- LT** light tone + \$0
- LU** soft white + \$0
- MS** metallic silver + \$0
- MT** medium tone + \$0
- SG** slate grey + \$0
- WL** sandstone + \$0

Sand Texture Paint

For textured paint on smooth steel (XS)

- 91** white + \$0
- BK** black + \$0
- CL** cool grey neutral + \$0
- G1** graphite + \$0
- WN** warm grey neutral + \$0
- 98** studio white + \$0

Step 8. Attachment Bracket

- 1A** for Action Office® Series 1 and 2 radiused-edge work surface + \$0
- 2A** for Action Office® Series 1 and 2 squared-edge work surface + \$0
- E1** for Ethospace® System + \$0
- F8** for Canvas Office Landscape® + \$0

Step 9. Front Finish

For veneer front (A.)

Recut Veneer

- RA** light ash A + \$0
- RK** mahogany dark A + \$0
- RM** mahogany A + \$0

Arc Pull Support Pedestal *continued*

Tu® Metal Storage

Wood Veneer		
2U	light brown walnut <input type="checkbox"/> A	+\$107
40	dark brown walnut <input type="checkbox"/> A	+\$107
ED	aged cherry <input type="checkbox"/> A	+\$107
EK	medium red walnut <input type="checkbox"/> A	+\$107
EW	medium matte walnut <input type="checkbox"/> A	+\$107
ET	clear on ash <input type="checkbox"/> A	+\$107
EU	oak on ash <input type="checkbox"/> A	+\$107
EV	walnut on ash <input type="checkbox"/> A	+\$107
UL	natural maple <input type="checkbox"/> A	+\$107
UX	walnut on cherry <input type="checkbox"/> A	+\$107

Step 10. Lock		
KA	keyed alike	-\$10
KC	keyed differently, chrome	+\$0
KD	keyed differently, black	+\$0

Step 11. Pull Finish		
NH	brushed nickel	+\$0
NK	black nickel	+\$0

Step 12. Drawer Interior

For box/box/file (BBF)		
NN	none	+\$0
2M	drawer divider in box drawers, 2 file converters in file drawer	+\$25
3M	drawer divider in one box drawer, pencil tray in one box drawer, 2 file converters in file drawer	+\$25
C51	storage organizer including hanging file holder bin, utility tray and two containers <input type="checkbox"/> A	+\$120

For file/file (FF)		
NN	none	+\$0
1M	2 file converters in each file drawer	+\$25
C51	storage organizer including hanging file holder bin, utility tray and two containers <input type="checkbox"/> A	+\$120

W-Pull Support Pedestal

LW150.

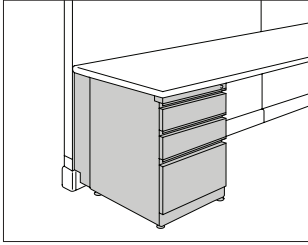

Product Information

Description

This pedestal attaches to both a work surface and a panel or frame at either the end of a run or mid-run to provide support. It eliminates the need for a return panel/frame and connector or a work surface support panel. It has a smooth-steel case, full-width pulls, and 1 3/4" leveling glides. It attaches under a work surface on the left or right side.

Attachment hardware and support bracket are included.

The actual pedestal depth is 19 3/8", 23 1/4", or 27 3/4". A 20"-deep pedestal supports a 24"-deep work surface. A 24"-deep pedestal supports a 30"-deep Ethospace® work surface with cable management trough. A 28"-deep pedestal supports a 30"-deep work surface.

Drawers are available with full-extension or 3/4-extension slides. A drawer divider, utility tray or storage organizer is optional for box drawers. File drawers hold letter-size front-to-back hanging files. File converters are optional for letter-, legal-, and A4-size side-to-side hanging files.

Notes

Order optional accessories separately:

- Drawer divider (LG903.)
- File compressor (LG908)
- File converter (LG907)
- File drawer organizer (LG901)
- Pedestal stationery divider (LG905)
- Utility tray (LG906)
- Storage organizer (LG910)

Storage organizer includes a hanging file holder, utility tray (pencil tray) and 2 containers. The storage organizer frame color matches the drawer interior; file holder and containers are 91 white; utility tray is black.

For keyed-alike locks, order lock plugs separately. See Keyed-Alike Information in Appendices.

Dimensions

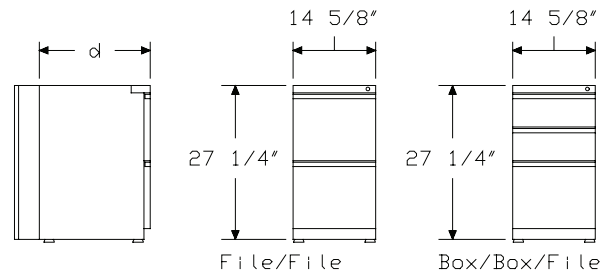

Specification Information		
Step 1.		
LW150.		
Step 2. Depth		
20	20" deep	
24	24" deep	
28	28" deep	
Step 3. Configuration		
BBF	box/box/file	
FF	file/file	
Prices for Steps 1-3.		
		BBF FF
LW150. 20		\$605 562
24		\$633 603
28		\$668 639
Step 4. Slides		
<i>For box/box/file (BBF)</i>		
SR	3/4"-extension roller slides on box drawer, full-extension ball bearing on file drawer	+\$0
SB	full-extension ball-bearing	+\$50
<i>For file/file (FF)</i>		
SB	full-extension ball-bearing	+\$0
Step 5. Paint/Steel Type		
SS	smooth paint on smooth steel	+\$0
XS	textured paint on smooth steel	+\$0

Step 6. Surface Finish		
<i>For smooth paint on smooth steel (SS)</i>		
8Q	folkstone grey	+\$0
98	studio white	+\$0
BU	black umber	+\$0
CN	metallic champagne	+\$0
EH	metallic bronze	+\$0
HF	inner tone light	+\$0
LT	light tone	+\$0
LU	soft white	+\$0
MS	metallic silver	+\$0
MT	medium tone	+\$0
SG	slate grey	+\$0
WL	sandstone	+\$0
Sand Texture Paint		
<i>For textured paint on smooth steel (XS)</i>		
91	white	+\$0
98	studio white	+\$0
BK	black	+\$0
CL	cool grey neutral	+\$0
G1	graphite	+\$0
WN	warm grey neutral	+\$0
Step 7. Attachment Bracket		
1A	for Action Office® Series 1 and 2 radiused-edge work surface	+\$0
2A	for Action Office® Series 1 and 2 squared-edge work surface	+\$0
E1	for Ethospace® System	+\$0
F8	for Canvas Office Landscape®	+\$0
Step 8. Lock		
KA	keyed alike	-\$10
KC	keyed differently, chrome	+\$0
KD	keyed differently, black	+\$0

W-Pull Support Pedestal *continued*

Step 9. Drawer Interior

For 20" deep (20) or 24" deep (24) with box/box/file (BBF)

NN	none	+\$0
2M	drawer divider in box drawers, 2 file converters in file drawer	+\$25
3M	drawer divider in one box drawer, pencil tray in one box drawer, 2 file converters in file drawer	+\$25
C51	storage organizer including hanging file holder bin, utility tray and two containers A	+\$120

For 28" deep (28) with box/box/file (BBF)

NN	none	+\$0
2M	drawer divider in box drawers, 2 file converters in file drawer	+\$25
3M	drawer divider in one box drawer, pencil tray in one box drawer, 2 file converters in file drawer	+\$25

For 20" deep (20) or 24" deep (24) with file/file (FF)

NN	none	+\$0
1M	2 file converters in each file drawer	+\$25
C51	storage organizer including hanging file holder bin, utility tray and two containers A	+\$120

For 28" deep (28) with file/file (FF)

NN	none	+\$0
1M	2 file converters in each file drawer	+\$25

V-Pull Support Pedestal

LV150.

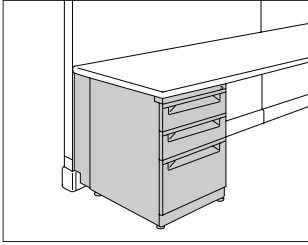

Tu® Metal Storage

Product Information

Description

This pedestal attaches to both a work surface and a panel or frame at either the end of a run or mid-run to provide support. It eliminates the need for a return panel/frame and connector or a work surface support panel. It has a smooth-steel case, full-width recessed pulls, and 1³/₄" leveling glides. It attaches under a work surface on the left or right side.

Attachment hardware and support bracket are included.

The actual pedestal depth is 19³/₈" , 23¹/₄" , or 27³/₄". A 20"-deep pedestal supports a 24"-deep work surface. A 24"-deep pedestal supports a 30"-deep Ethospace® work surface with cable management trough. A 28"-deep pedestal supports a 30"-deep work surface.

Drawers are available with full-extension or 3/4-extension slides. A drawer divider, utility tray or storage organizer is optional for box drawers. File drawers hold letter-size front-to-back hanging files. File converters are optional for letter-, legal-, and A4-size side-to-side hanging files.

Notes

Order optional accessories separately:

- Drawer divider (LG903.)
- File compressor (LG908)
- File converter (LG907)
- File drawer organizer (LG901)
- Pedestal stationery divider (LG905)
- Utility tray (LG906)
- Storage organizer (LG910)

Storage organizer includes a hanging file holder, utility tray (pencil tray) and 2 containers. The storage organizer frame color matches the drawer interior; file holder and containers are 91 white; utility tray is black.

For keyed-alike locks, order lock plugs separately. See Keyed-Alike Information in Appendices.

Dimensions

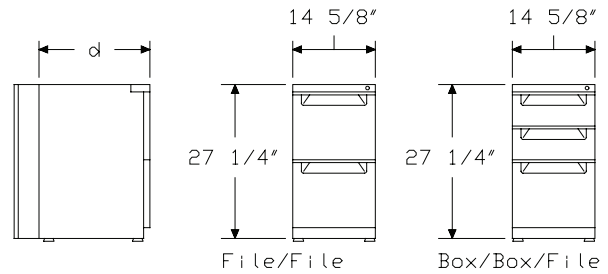

V-Pull Support Pedestal *continued*

Specification Information		
Step 1.		
LV150.		
Step 2. Depth		
20	20" deep	
24	24" deep	
28	28" deep	
Step 3. Configuration		
BBF	box/box/file	
FF	file/file	
Prices for Steps 1-3.		
		BBF FF
LV150. 20		\$600 557
24		\$628 598
28		\$663 632
Step 4. Slides		
<i>For box/box/file (BBF)</i>		
SR	¾-extension roller slides on box drawer, full-extension ball bearing on file drawer	+\$0
SB	full-extension ball-bearing	+\$50
<i>For file/file (FF)</i>		
SB	full-extension ball-bearing	+\$0
Step 5. Paint/Steel Type		
SS	smooth paint on smooth steel	+\$0
XS	textured paint on smooth steel	+\$0

Step 6. Surface Finish		
<i>For smooth paint on smooth steel (SS)</i>		
8Q	folkstone grey	+\$0
98	studio white	+\$0
BU	black umber	+\$0
CN	metallic champagne	+\$0
EH	metallic bronze	+\$0
HF	inner tone light	+\$0
LT	light tone	+\$0
LU	soft white	+\$0
MS	metallic silver	+\$0
MT	medium tone	+\$0
SG	slate grey	+\$0
WL	sandstone	+\$0
Sand Texture Paint		
<i>For textured paint on smooth steel (XS)</i>		
91	white	+\$0
98	studio white	+\$0
BK	black	+\$0
CL	cool grey neutral	+\$0
G1	graphite	+\$0
WN	warm grey neutral	+\$0
Step 7. Attachment Bracket		
1A	for Action Office® Series 1 and 2 radiused-edge work surface	+\$0
2A	for Action Office® Series 1 and 2 squared-edge work surface	+\$0
E1	for Ethospace® System	+\$0
F8	for Canvas Office Landscape®	+\$0
Step 8. Lock		
KA	keyed alike	-\$10
KC	keyed differently, chrome	+\$0
KD	keyed differently, black	+\$0

V-Pull Support Pedestal *continued*

Tu® Metal Storage

Step 9. Drawer Interior

For 20" deep (20) or 24" deep (24) with box/box/file (BBF)

NN	none	+\$0
2M	drawer divider in box drawers, 2 file converters in file drawer	+\$25
3M	drawer divider in one box drawer, pencil tray in one box drawer, 2 file converters in file drawer	+\$25
C51	storage organizer including hanging file holder bin, utility tray and two containers A	+\$120

For 28" deep (28) with box/box/file (BBF)

NN	none	+\$0
2M	drawer divider in box drawers, 2 file converters in file drawer	+\$25
3M	drawer divider in one box drawer, pencil tray in one box drawer, 2 file converters in file drawer	+\$25

For 20" deep (20) or 24" deep (24) with file/file (FF)

NN	none	+\$0
1M	2 file converters in each file drawer	+\$25
C51	storage organizer including hanging file holder bin, utility tray and two containers A	+\$120

For 28" deep (28) with file/file (FF)

NN	none	+\$0
1M	2 file converters in each file drawer	+\$25

Bar Pull Suspended Pedestal

LK13A.
LK13D.

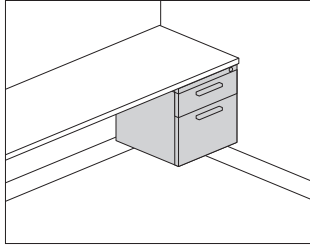

Product Information

Description

This pedestal mounts under a predrilled hanging or freestanding work surface. It has a smooth-steel case and applied metal bar pulls.

Mounting hardware included.

Actual pedestal depth is 19³/₈".

The box drawer is available with full-extension or 3/4-extension slides.

The file drawer has full-extension slides and holds letter-size front-to-back hanging files.

Notes

To add drawer divider, pencil tray, and file converters to drawer interiors, specify option (2M) or (3M).

For full extension slides on box drawer, specify option (SB).

Pedestal will not mount under the following products:

- Action Office® table
- Ethospace® peninsula with access
- Ethospace work surface in off-module application

Grain direction is vertical for veneer-front pedestals.

Order optional accessories separately:

- Drawer divider (LG903.)
- File compressor (LG908)
- File converter (LG907)
- File drawer organizer (LG901)
- Pedestal stationery divider (LG905)
- Utility tray (LG906)
- Storage organizer (LG910)

Storage organizer includes a hanging file holder, utility tray (pencil tray) and 2 containers. Storage organizer frame color matches drawer interior; file holder and containers are 91 white; utility tray is black.

For keyed-alike locks, order lock plugs separately. See Keyed-Alike Information in Appendices.

Dimensions

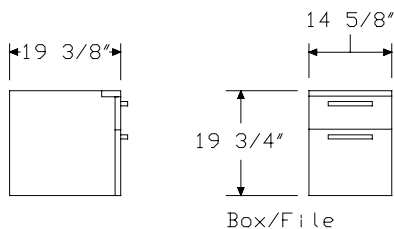

Specification Information

Step 1.

LK13

Step 2. Front Material

D.20BF painted metal front

A.20BF veneer front A

Prices for Steps 1-2.

LK13D.20BF \$471

LK13A.20BF \$648

Step 3. Slides

SR 3/4-extension roller slides on box drawer, full-extension ball bearing on file drawer +\$0

SB full-extension ball-bearing +\$25

Step 4. Paint/Steel Type

SS smooth paint on smooth steel +\$0

XS textured paint on smooth steel +\$0

Step 5. Surface Finish

For smooth paint on smooth steel (SS)

98 studio white +\$0

8Q folkstone grey +\$0

BU black umber +\$0

HF inner tone light +\$0

LT light tone +\$0

LU soft white +\$0

MT medium tone +\$0

SG slate grey +\$0

WL sandstone +\$0

CN metallic champagne +\$0

EH metallic bronze +\$0

MS metallic silver +\$0

Sand Texture Paint

For textured paint on smooth steel (XS)

91 white +\$0

98 studio white +\$0

BK black +\$0

CL cool grey neutral +\$0

G1 graphite +\$0

WN warm grey neutral +\$0

Bar Pull Suspended Pedestal

continued

Tu® Metal Storage

Step 6. Front Finish For veneer front (A.2oBF)

Recut Veneer		
RA	light ash <input type="checkbox"/>	+\$0
RK	mahogany dark <input type="checkbox"/>	+\$0
RM	mahogany <input type="checkbox"/>	+\$0

Wood Veneer		
2U	light brown walnut <input type="checkbox"/>	+\$75
40	dark brown walnut <input type="checkbox"/>	+\$75
ED	aged cherry <input type="checkbox"/>	+\$75
EK	medium red walnut <input type="checkbox"/>	+\$75
EW	medium matte walnut <input type="checkbox"/>	+\$75
ET	clear on ash <input type="checkbox"/>	+\$75
EV	walnut on ash <input type="checkbox"/>	+\$75
UL	natural maple <input type="checkbox"/>	+\$75
UX	walnut on cherry <input type="checkbox"/>	+\$75

Step 7. Lock		
KA	keyed alike	-\$10
KC	keyed differently, chrome	+\$0
KD	keyed differently, black	+\$0

Step 8. Pull Finish

Metallic Paint		
CN	metallic champagne	+\$0
MS	metallic silver	+\$0

Sand Texture Paint		
79	green apple	+\$15
BK	black	+\$0
MY3	yellow oxide	+\$15
RO	red	+\$15
TRQ	turquoise	+\$15

Smooth Paint		
8Q	folkstone grey	+\$0
91	white	+\$0
98	studio white	+\$0
G1	graphite	+\$0
WL	sandstone	+\$0
XX	no pull	+\$0

Step 9. Drawer Interior

NN	none	+\$0
4M	drawer divider in box drawer, 2 file converters in file drawer	+\$20
5M	pencil tray in box drawer, 2 file converters in file drawer	+\$20
C51	storage organizer including hanging file holder bin, utility tray and two containers <input type="checkbox"/>	+\$120

Arc Pull Suspended Pedestal

LQ13A.
LQ13D.

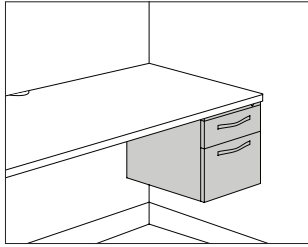

Product Information

Description

This pedestal mounts under a predrilled hanging or freestanding work surface. It has a smooth-steel case and applied metal arc pulls.

Mounting hardware included.

Actual pedestal depth is 19^{3/8}".

The box drawer is available with full-extension or 3/4-extension slides.

The file drawer has full-extension slides and holds letter-size front-to-back hanging files.

Notes

Pull design conforms to guidelines of Americans with Disabilities Act (ADA).

To add drawer divider, pencil tray, file converters and storage organizer to drawer interiors, specify option (4M), (5M) or (C51).

For full extension slides on box drawer, specify option (SB).

Pedestal will not mount under the following products:

- Action Office® table
- Ethospace® peninsula with access
- Ethospace work surface in off-module application

Grain direction is vertical for veneer-front pedestals.

Order optional accessories separately:

- Drawer divider (LG903.)
- File compressor (LG908)
- File converter (LG907)
- File drawer organizer (LG901)
- Pedestal stationery divider (LG905)
- Utility tray (LG906)
- Storage organizer (LG910)

Storage organizer includes a hanging file holder, utility tray (pencil tray) and 2 containers. The storage organizer frame color matches the drawer interior; file holder and containers are 91 white; utility tray is black.

For keyed-alike locks, order lock plugs separately. See Keyed-Alike

Information in Appendices.

Dimensions

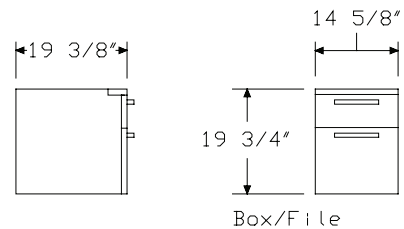

Arc Pull Suspended Pedestal

continued

Tu® Metal Storage

Specification Information

Step 1.

LQ13

Step 2. Front Material

D.20BF painted metal front

A.20BF veneer front A

Prices for Steps 1-2.

LQ13D.20BF \$471

LQ13A.20BF \$648

Step 3. Slides

SR ¾-extension roller slides on box drawer, full-extension ball bearing on file drawer +\$0

SB full-extension ball-bearing +\$25

Step 4. Paint/Steel Type

SS smooth paint on smooth steel +\$0

XS textured paint on smooth steel +\$0

Step 5. Surface Finish

For smooth paint on smooth steel (SS)

8Q folkstone grey +\$0

98 studio white +\$0

BU black umber +\$0

CN metallic champagne +\$0

EH metallic bronze +\$0

HF inner tone light +\$0

LT light tone +\$0

LU soft white +\$0

MS metallic silver +\$0

MT medium tone +\$0

SG slate grey +\$0

WL sandstone +\$0

Sand Texture Paint

For textured paint on smooth steel (XS)

91 white +\$0

98 studio white +\$0

BK black +\$0

CL cool grey neutral +\$0

G1 graphite +\$0

WN warm grey neutral +\$0

Step 6. Front Finish

For veneer front (A.20BF)

Recut Veneer

RA light ash A +\$0

RK mahogany dark A +\$0

RM mahogany A +\$0

Wood Veneer

2U light brown walnut A +\$75

40 dark brown walnut A +\$75

ED aged cherry A +\$75

EK medium red walnut A +\$75

EW medium matte walnut A +\$75

ET clear on ash A +\$75

EU oak on ash A +\$75

EV walnut on ash A +\$75

UL natural maple A +\$75

UX walnut on cherry A +\$75

Step 7. Lock

KA keyed alike -\$10

KC keyed differently, chrome +\$0

KD keyed differently, black +\$0

Step 8. Pull Finish

NH brushed nickel +\$0

NK black nickel +\$0

Step 9. Drawer Interior

NN none +\$0

4M drawer divider in box drawer, 2 file converters in file drawer +\$20

5M pencil tray in box drawer, 2 file converters in file drawer +\$20

C51 storage organizer including hanging file holder bin, utility tray and two containers A +\$120

W-Pull Suspended Pedestal

LW130.

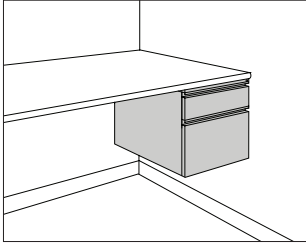

Product Information

Description

This pedestal mounts under a predrilled hanging or freestanding work surface. It has a smooth-steel case and full-width pulls. Mounting hardware included.

Actual pedestal depth is 19 3/8".

Drawers are available with full-extension or 3/4-extension slides. A drawer divider, utility tray or storage organizer is optional for box drawers. The file drawer holds letter-size front-to-back hanging files. File converters are optional for letter-, legal-, and A4-size side-to-side hanging files.

Notes

Pedestal will not mount under the following products:

- Action Office® table
- Ethospace® peninsula with access cover
- Ethospace work surface in off-module application

Order optional accessories separately:

- Drawer divider (LG903.)
- File compressor (LG908)
- File converter (LG907)
- File drawer organizer (LG901)
- Pedestal stationery divider (LG905)
- Utility tray (LG906)
- Storage organizer (LG910)

Storage organizer includes a hanging file holder, utility tray (pencil tray) and 2 containers. The storage organizer frame color matches the drawer interior; file holder and containers are 91 white; utility tray is black.

For keyed-alike locks, order lock plugs separately. See Keyed-Alike Information in Appendices.

Dimensions

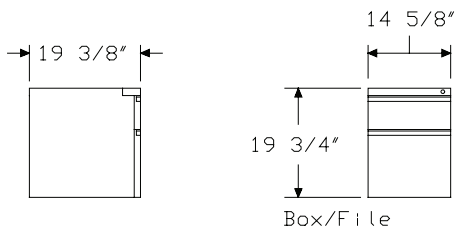

Specification Information

Step 1.

LW130.20BF \$383

Step 2. Slides

SR 3/4-extension roller slides on box drawer, full-extension ball bearing on file drawer +\$0

SB full-extension ball-bearing +\$25

Step 3. Paint/Steel Type

SS smooth paint on smooth steel +\$0

XS textured paint on smooth steel +\$0

Step 4. Surface Finish

For smooth paint on smooth steel (SS)

8Q folkstone grey +\$0

98 studio white +\$0

BU black umber +\$0

CN metallic champagne +\$0

EH metallic bronze +\$0

HF inner tone light +\$0

LT light tone +\$0

LU soft white +\$0

MS metallic silver +\$0

MT medium tone +\$0

SG slate grey +\$0

WL sandstone +\$0

Sand Texture Paint

For textured paint on smooth steel (XS)

91 white +\$0

98 studio white +\$0

BK black +\$0

CL cool grey neutral +\$0

G1 graphite +\$0

WN warm grey neutral +\$0

W-Pull Suspended Pedestal

continued

Tu® Metal Storage

Step 5. Lock		
KA	keyed alike	-\$10
KC	keyed differently, chrome	+\$0
KD	keyed differently, black	+\$0

Step 6. Drawer Interior		
NN	none	+\$0
4M	drawer divider in box drawer, 2 file converters in file drawer	+\$20
5M	pencil tray in box drawer, 2 file converters in file drawer	+\$20
C51	storage organizer including hanging file holder bin, utility tray and two containers <input type="checkbox"/>	+\$120

V-Pull Suspended Pedestal

LV130.

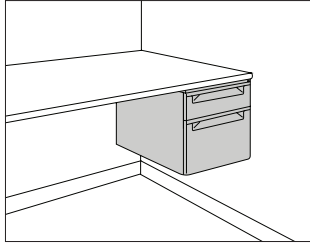

Product Information

Description

This pedestal mounts under a predrilled hanging or freestanding work surface. It has a smooth-steel case and full-width recessed pulls.

Mounting hardware included.

Actual pedestal depth is 19 3/8".

Drawers are available with full-extension or 3/4-extension slides. A drawer divider, utility tray or storage organizer is optional for box drawers. The file drawer holds letter-size front-to-back hanging files. File converters are optional for letter-, legal-, and A4-size side-to-side hanging files.

Notes

Pedestal will not mount under the following products:

- Action Office® table
- Ethospace® peninsula with access cover
- Ethospace work surface in off-module application

Order optional accessories separately:

- Drawer divider (LG903.)
- File compressor (LG908)
- File converter (LG907)
- File drawer organizer (LG901)
- Pedestal stationery divider (LG905)
- Utility tray (LG906)
- Storage organizer (LG910)

Storage organizer includes a hanging file holder, utility tray (pencil tray) and 2 containers. The storage organizer frame color matches the drawer interior; file holder and containers are 91 white; utility tray is black.

For keyed-alike locks, order lock plugs separately. See Keyed-Alike Information in Appendices.

Dimensions

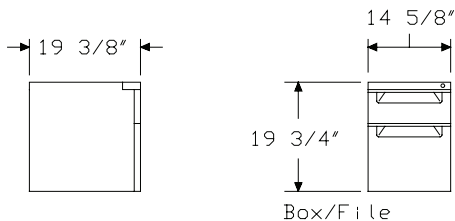

Specification Information

Step 1.

LV130.20BF \$412

Step 2. Slides

SR 3/4-extension roller slides on box drawer, full-extension ball bearing on file drawer +\$0

SB full-extension ball-bearing +\$25

Step 3. Paint/Steel Type

SS smooth paint on smooth steel +\$0

XS textured paint on smooth steel +\$0

Step 4. Surface Finish

For smooth paint on smooth steel (SS)

8Q folkstone grey +\$0

98 studio white +\$0

BU black umber +\$0

CN metallic champagne +\$0

EH metallic bronze +\$0

HF inner tone light +\$0

LT light tone +\$0

LU soft white +\$0

MS metallic silver +\$0

MT medium tone +\$0

SG slate grey +\$0

WL sandstone +\$0

Sand Texture Paint

For textured paint on smooth steel (XS)

91 white +\$0

98 studio white +\$0

BK black +\$0

CL cool grey neutral +\$0

G1 graphite +\$0

WN warm grey neutral +\$0

V-Pull Suspended Pedestal *continued*

Tu® Metal Storage

Step 5. Lock		
KA	keyed alike	-\$10
KC	keyed differently, chrome	+\$0
KD	keyed differently, black	+\$0
Step 6. Drawer Interior		
NN	none	+\$0
4M	drawer divider in box drawer, 2 file converters in file drawer	+\$20
5M	pencil tray in box drawer, 2 file converters in file drawer	+\$20
C51	storage organizer including hanging file holder bin, utility tray and two containers <input type="checkbox"/>	+\$120

Pedestal Add-On Cushion Top

LG890.

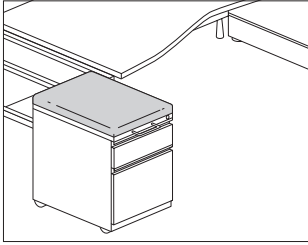

Product Information

Description

This 1"- or 2"-high cushion top is retrofit to a mobile pedestal with a flat metal top and provides temporary guest seating. Hook-and-loop fastener strips are included to attach cushion top to flat metal top.

Notes

Cushion top accepts Customer's Own Material (COM). Yardage is estimated for nondirectional, 54"-wide fabrics. Order 1/2 yard of fabric per cushion. For odd number of cushions, round up to next whole yard. For information on multiple quantities or directional fabrics, contact COM Department. See Order Information in Appendices.

Dimensions

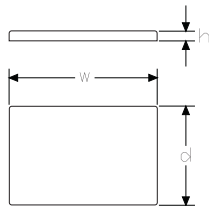

Specification Information

Step 1.

LG890.

Step 2. Height

- 1 1" high
- 2 2" high

Step 3. Depth

- 20 20" deep
- 24 24" deep

Prices for Steps 1-3.

	20	24
LG890. 1	\$129	161
2	\$153	192

Step 4. Cushion Top Fabric

See application chart and textiles list for fabric usage and numbers. First 2 digits of number indicate fabric line; remaining digit(s) indicate fabric color.

Price Category 1	+\$0
Price Category 2	+\$43
Price Category 3	+\$61
Price Category 4	+\$81
Price Category 7 A	+\$147
Price Category 9	+\$938
Price Category B	+\$29
Price Category C	+\$39
Price Category E	+\$61
Price Category G	+\$103
Price Category H	+\$125

Storage Organizer

LG910.

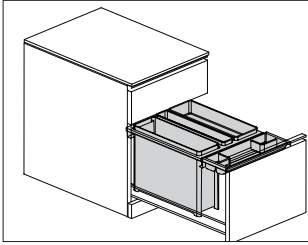

Tu® Metal Storage

Product Information

Description

This storage organizer includes 1 hanging file holder, 1 utility tray (pencil tray), and 2 containers. The storage organizer frame color matches the drawer interior. File holder and containers are 91 white, and the utility tray is black.

Notes

Storage organizer can be used in the following products:

- Tu® pedestals
- Tu storage towers

For 20" deep file drawer, storage organizer will include hanging file holder and 2 containers in 1 drawer, and utility tray in separate drawer.

For 24" deep drawer, utility tray can be placed inside the same drawer as the storage organizer unit.

Dimensions

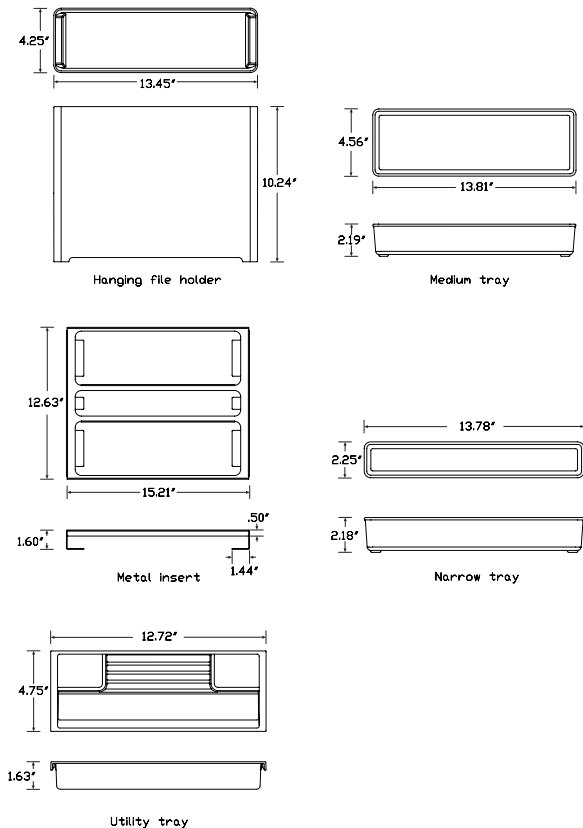

Specification Information

Step 1.

LG910. A

\$182

File Drawer Organizer

LG901

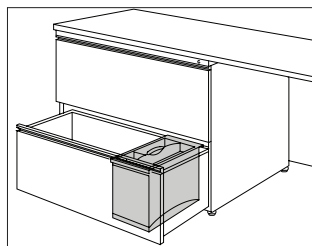

Product Information

Description

This 2-sectioned organizer fits into any file drawer arranged for letter-size filing. The removable top section stores computer disks and other small items. The bottom section stores larger items or can be divided into 3 compartments; it includes 2 vertical dividers. Finish is black umber.

Dimensions

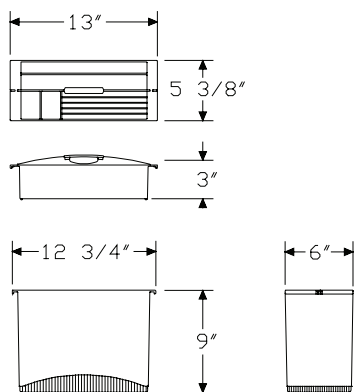

Specification Information

Step 1.

LG901

\$84

Drawer Divider, Tu® Pedestal

LG903.

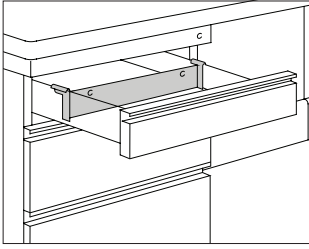

Tu® Metal Storage

Product Information

Description
 This adjustable divider is used in a pencil or box drawer. Finish is black umber.

Notes

- Divider can be used in the following products:
- 5000 Series furniture with B- and F-pull pedestals
 - Tu® Q-, R-, T-, V-, and W-pull pedestals
 - Tu storage towers

Dimensions

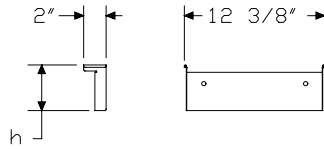

Specification Information

Step 1.
LG903.

Step 2. Usage

- 3** for pencil drawer
- 6** for box drawer

Prices for Steps 1-2.

LG903. 3	\$16
6	\$17

Stationery Divider, Tu® Pedestal LG905

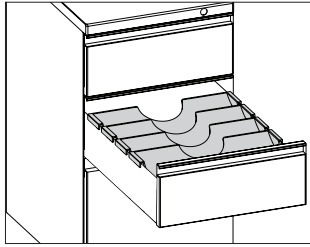

Product Information

Description

These 4 removable dividers are used in box drawers. Finish is black umber.

Notes

Dividers can be used in the following products:

- 5000 Series furniture with B- and F-pull pedestals
- Tu® Q-, R-, T-, V-, and W-pull pedestals
- Tu storage towers

Dimensions

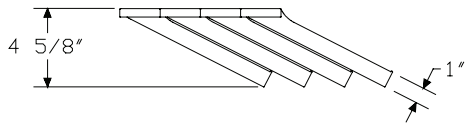

Specification Information

Step 1.

LG905

\$56

Tu® Metal Storage

Utility Tray, Tu® Pedestal

LG906

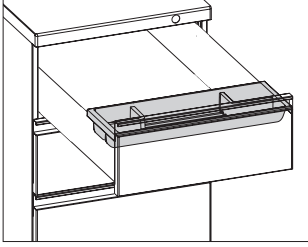

Tu® Metal Storage

Product Information

Description

This sectioned tray stores pencils and small items in a pencil or box drawer. Finish is black umber.

Notes

Tray can be used in the following products:

- 5000 Series furniture with B- and F-pull pedestals
- Tu® Q-, R-, T-, V-, and W-pull pedestals
- Tu storage towers

Dimensions

Specification Information

Step 1.

LG906

\$20

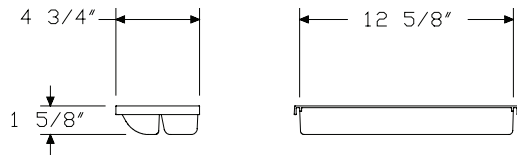

File Converter, Tu®

LG907

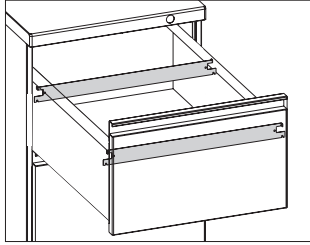

Product Information

Description

These black umber bars convert a file drawer to hold letter-, legal-, and A4-size side-to-side hanging files. 2 converters are used per drawer. Package contains 4.

Notes

- Converters can be used in the following products:
- 5000 Series furniture with B- and F-pull pedestals
 - Tu® Q-, R-, T-, V-, and W-pull pedestals
 - Tu storage towers

Dimensions

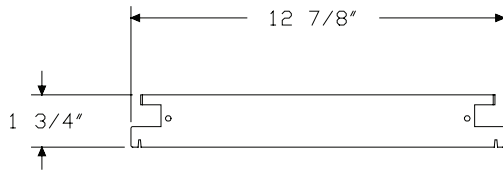

Specification Information

Step 1.

LG907

\$28

Tu® Metal Storage

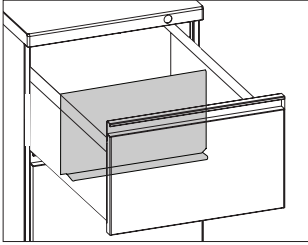

Tu® Metal Storage

Product Information

Description

These compressors lock into slots in the bottom of a pedestal file drawer to divide non-hanging files. Finish is black umber. Package contains 4.

Notes

Compressors can be used in the following products:

- 5000 Series furniture with B- and F-pull pedestals
- Tu® Q-, R-, T-, V-, and W-pull pedestals
- Tu storage towers

Dimensions

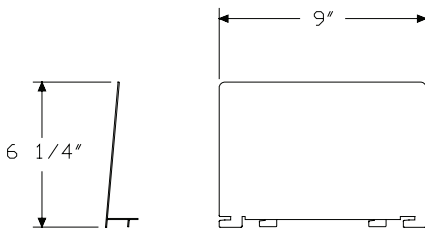

Specification Information

Step 1.

LG908

\$46

Bar-Pull Freestanding Lateral File LK20A.
LK20D.

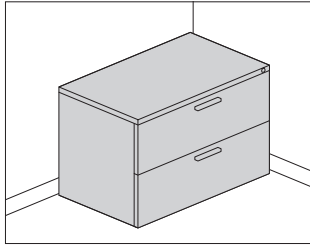

Product Information

Description

This lateral file has a painted or veneer front, smooth-steel case, and applied metal bar pulls. It includes 1" leveling glides and a positive interlock system that permits only 1 drawer or pullout shelf to open at a time. Drawers can be specified with side-to-side or front-to-back filing rails to accommodate letter-, legal-, and A4-size hanging files. The pullout shelf includes 3 file dividers.

Actual file depth is 19³/₈". Actual file width is 29⁵/₈", 35⁵/₈", or 41⁵/₈".

Interior height of the flipper door with pullout shelf is 10¹/₄". Raised-height configuration adds 1/2" to overall height to fill the space between the top of the file and the underside of a surface.

Notes

Base on 2 drawers, raised height option (1) aligns with base on Tu® storage towers.

2- or 3-high files that are not ganged or anchored require counterweights (option CB). When two 42"-wide, 4-high files are ganged side by side, each file requires a counterweight.

Counterweight specified with file is permanently installed. To order removable counterweight, specify file with no counterweight option (NO), and order counterweight (LG909.) separately.

Veneer-front lateral files have a vertical grain direction.

Order optional accessories separately:

- File drawer organizer (LG901)
- Front-to-back filing rail (LG904.)
- Movable divider (9M100) - For flipper door with pullout shelf only
- Side-to-side filing rail (LG902.)

For keyed-alike locks, order lock plugs separately. See Keyed-Alike Information in Appendices.

Dimensions

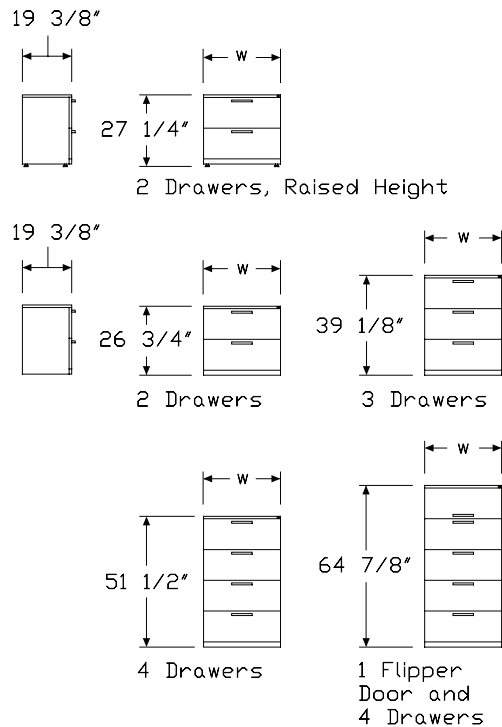

Bar-Pull Freestanding Lateral File

continued

Tu® Metal Storage

Specification Information

Step 1.

LK20

Step 2. Front Material

- D.** painted metal front
- A.** veneer front A

Step 3. Width

- 30** 30" wide
- 36** 36" wide
- 42** 42" wide

Step 4. Configuration

For painted metal front (D.)

- 1** 2 drawers, raised height
- 2** 2 drawers
- 3** 3 drawers
- 4** 4 drawers
- 5** 1 flipper door with pullout shelf and 4 drawers

For veneer front (A.)

- 1** 2 drawers, raised height
- 2** 2 drawers
- 3** 3 drawers
- 4** 4 drawers

Prices for Steps 1-4.

	1	2	3	4	5
LK20D. 30	\$1285	1285	1741	2082	2703
36	\$1344	1344	1794	2209	2804
42	\$1460	1460	1872	2322	2876

	1	2	3	4	5
LK20A. 30	\$1676	1676	2277	2755	—
36	\$1738	1738	2330	2887	—
42	\$1859	1859	2413	3006	—

Step 5. Paint/Steel Type

- SS** smooth paint on smooth steel +\$0
- XS** textured paint on smooth steel +\$0

Step 6. Surface Finish

For smooth paint on smooth steel (SS)

- 8Q** folkstone grey +\$0
- 98** studio white +\$0
- BU** black umber +\$0
- CN** metallic champagne +\$0
- EH** metallic bronze +\$0
- HF** inner tone light +\$0
- LT** light tone +\$0
- LU** soft white +\$0
- MS** metallic silver +\$0
- MT** medium tone +\$0
- SG** slate grey +\$0
- WL** sandstone +\$0

Sand Texture Paint

For textured paint on smooth steel (XS)

- 91** white +\$0
- 98** studio white +\$0
- BK** black +\$0
- CL** cool grey neutral +\$0
- G1** graphite +\$0
- WN** warm grey neutral +\$0

Step 7. Front Finish

Recut Veneer

For 2 drawers, raised height (1) or 2 drawers (2)

- RA** light ash A +\$0
- RK** mahogany dark A +\$0
- RM** mahogany A +\$0

Wood Veneer

For 2 drawers, raised height (1) or 2 drawers (2)

- 2U** light brown walnut A +\$74
- 40** dark brown walnut A +\$74
- ED** aged cherry A +\$74
- EK** medium red walnut A +\$74
- EW** medium matte walnut A +\$74
- ET** clear on ash A +\$74
- EV** walnut on ash A +\$74
- UL** natural maple A +\$74
- UX** walnut on cherry A +\$74

Bar-Pull Freestanding Lateral File

continued

Recut Veneer		
<i>For 3 drawers (3)</i>		
RA	light ash <input type="checkbox"/> A	+\$0
RK	mahogany dark <input type="checkbox"/> A	+\$0
RM	mahogany <input type="checkbox"/> A	+\$0

Wood Veneer		
<i>For 3 drawers (3)</i>		
2U	light brown walnut <input type="checkbox"/> A	+\$114
40	dark brown walnut <input type="checkbox"/> A	+\$114
ED	aged cherry <input type="checkbox"/> A	+\$114
EK	medium red walnut <input type="checkbox"/> A	+\$114
EW	medium matte walnut <input type="checkbox"/> A	+\$114
ET	clear on ash <input type="checkbox"/> A	+\$114
EV	walnut on ash <input type="checkbox"/> A	+\$114
UL	natural maple <input type="checkbox"/> A	+\$114
UX	walnut on cherry <input type="checkbox"/> A	+\$114

Recut Veneer		
<i>For 4 drawers (4)</i>		
RA	light ash <input type="checkbox"/> A	+\$0
RK	mahogany dark <input type="checkbox"/> A	+\$0
RM	mahogany <input type="checkbox"/> A	+\$0

Wood Veneer		
<i>For 4 drawers (4)</i>		
2U	light brown walnut <input type="checkbox"/> A	+\$154
40	dark brown walnut <input type="checkbox"/> A	+\$154
ED	aged cherry <input type="checkbox"/> A	+\$154
EK	medium red walnut <input type="checkbox"/> A	+\$154
EW	medium matte walnut <input type="checkbox"/> A	+\$154
ET	clear on ash <input type="checkbox"/> A	+\$154
EV	walnut on ash <input type="checkbox"/> A	+\$154
UL	natural maple <input type="checkbox"/> A	+\$154
UX	walnut on cherry <input type="checkbox"/> A	+\$154

Step 8. Lock		
KA	keyed alike	-\$10
KC	keyed differently, chrome	+\$0
KD	keyed differently, black	+\$0

Step 9. Pull Finish		
Metallic Paint		
CN	metallic champagne	+\$0
MS	metallic silver	+\$0

Sand Texture Paint		
79	green apple	+\$15
BK	black	+\$0
MY3	yellow oxide	+\$15
RO	red	+\$15
TRQ	turquoise	+\$15

Smooth Paint		
8Q	folkstone grey	+\$0
91	white	+\$0
98	studio white	+\$0
G1	graphite	+\$0
WL	sandstone	+\$0

Step 10. Counterweight				
		30	36	42
NO	no counterweight (must gang or anchor)	+\$0	0	0
CB	counterweight (recommended)	+\$50	95	95

Step 11. Drawer Interior			
<i>For 2 drawers, raised height (1), 2 drawers (2), 3 drawers (3), or 4 drawers (4)</i>			
1R	front-to-back filing rail		+\$0
2R	side-to-side filing rail		+\$0

<i>For 1 flipper door with pullout shelf and 4 drawers (5)</i>			
3R	front-to-back filing rail and dividers in flipper		+\$0
4R	side-to-side filing rail and dividers in flipper		+\$0

Arc Pull Freestanding Lateral File

LQ20A.
LQ20D.
LQ20L.

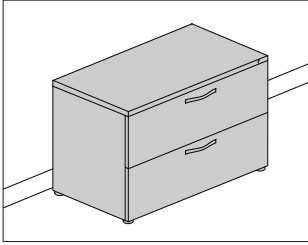

Tu® Metal Storage

Product Information

Description

This lateral file has a painted, laminate, or veneer front, smooth-steel case, and applied metal arc pulls. It includes 1" leveling glides and a positive interlock system that permits only 1 drawer or pullout shelf to open at a time. Drawers can be specified with side-to-side or front-to-back filing rails to accommodate letter-, legal-, and A4-size hanging files. The pullout shelf includes 3 file dividers.

Actual file depth is 19³/₈". Actual file width is 29⁵/₈", 35⁵/₈", or 41⁵/₈".

Interior height of the flipper door with pullout shelf is 10¹/₄". Raised-height configuration adds 1/2" to overall height to fill the space between the top of the file and the underside of a surface.

Notes

Pull design conforms to guidelines of Americans with Disabilities Act (ADA).

Base and pull heights on 2 drawers, raised height option (1) align with arc pull Tu® storage towers.

2- or 3-high files that are not ganged or anchored require counterweights (option CB). When two 42"-wide, 4-high files are ganged side by side, each file requires a counterweight.

Counterweight specified with file is permanently installed. To order removable counterweight, specify file with no counterweight (option NO), and order counterweight (LG909) separately.

Accepts Tu® add-on cushion top (LG891).

Veneer-front lateral files have a vertical grain direction.

Order optional accessories separately:

- File drawer organizer (LG901)
- Front-to-back filing rail (LG904.)
- Movable divider (9M100) - For flipper door with pullout shelf only
- Side-to-side filing rail (LG902.)

For keyed-alike locks, order lock plugs separately. See Keyed-Alike Information in Appendices.

Dimensions

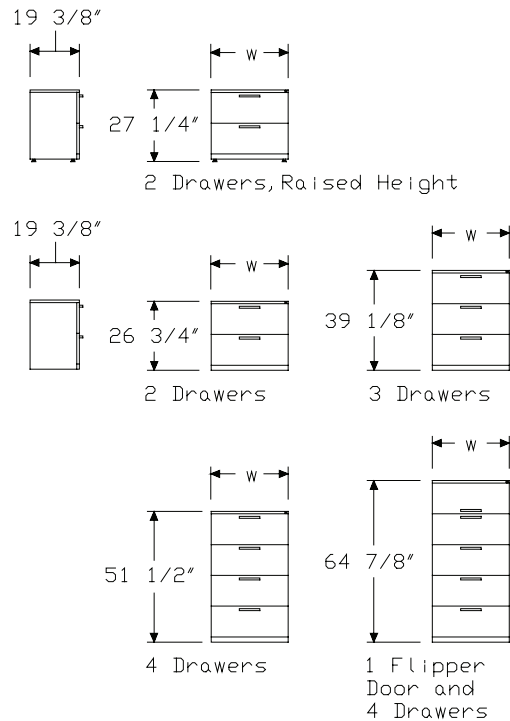

Arc Pull Freestanding Lateral File

continued

Specification Information

Step 1.

LQ20

Step 2. Front Material

- D.** painted metal front
- A.** veneer front A
- L.** laminate front

Step 3. Width

- 30** 30" wide
- 36** 36" wide
- 42** 42" wide

Step 4. Configuration

For painted metal front (D.)

- 1** 2 drawers, raised height
- 2** 2 drawers
- 3** 3 drawers
- 4** 4 drawers
- 5** 1 flipper door with pullout shelf and 4 drawers

For veneer front (A.)

- 1** 2 drawers, raised height
- 2** 2 drawers
- 3** 3 drawers
- 4** 4 drawers

For laminate front (L.)

- 1** 2 drawers, raised height
- 2** 2 drawers
- 3** 3 drawers
- 4** 4 drawers

Prices for Steps 1-4.

	1	2	3	4	5
LQ20D. 30	\$1285	1285	1741	2082	2703
36	\$1344	1344	1794	2209	2804
42	\$1460	1460	1872	2322	2876
LQ20A. 30	\$1676	1676	2277	2755	—
36	\$1738	1738	2330	2887	—
42	\$1859	1859	2413	3006	—

LQ20L. 30	\$1448	1448	1961	2347	—
36	\$1515	1515	2021	2490	—
42	\$1646	1646	2110	2618	—

Step 5. Paint/Steel Type

- SS** smooth paint on smooth steel +\$0
- XS** textured paint on smooth steel +\$0

Step 6. Surface Finish

For smooth paint on smooth steel (SS)

- 8Q** folkstone grey +\$0
- 98** studio white +\$0
- BU** black umber +\$0
- CN** metallic champagne +\$0
- EH** metallic bronze +\$0
- HF** inner tone light +\$0
- LT** light tone +\$0
- LU** soft white +\$0
- MS** metallic silver +\$0
- MT** medium tone +\$0
- SG** slate grey +\$0
- WL** sandstone +\$0

Sand Texture Paint

For textured paint on smooth steel (XS)

- 91** white +\$0
- 98** studio white +\$0
- BK** black +\$0
- CL** cool grey neutral +\$0
- G1** graphite +\$0
- WN** warm grey neutral +\$0

Step 7. Front Finish

Recut Veneer

For veneer front (A.) with 2 drawers, raised height (1), or 2 drawers (2)

- RA** light ash A +\$0
- RK** mahogany dark A +\$0
- RM** mahogany A +\$0

Arc Pull Freestanding Lateral File

continued

Tu® Metal Storage

Wood Veneer		
<i>For veneer front (A.) with 2 drawers, raised height (1), or 2 drawers (2)</i>		
2U	light brown walnut <input type="checkbox"/> A	+\$74
40	dark brown walnut <input type="checkbox"/> A	+\$74
ED	aged cherry <input type="checkbox"/> A	+\$74
EK	medium red walnut <input type="checkbox"/> A	+\$74
EW	medium matte walnut <input type="checkbox"/> A	+\$74
ET	clear on ash <input type="checkbox"/> A	+\$74
EU	oak on ash <input type="checkbox"/> A	+\$74
EV	walnut on ash <input type="checkbox"/> A	+\$74
UL	natural maple <input type="checkbox"/> A	+\$74
UX	walnut on cherry <input type="checkbox"/> A	+\$74

Recut Veneer		
<i>For veneer front (A.) with 3 drawers (3)</i>		
RA	light ash <input type="checkbox"/> A	+\$0
RK	mahogany dark <input type="checkbox"/> A	+\$0
RM	mahogany <input type="checkbox"/> A	+\$0

Wood Veneer		
<i>For veneer front (A.) with 3 drawers (3)</i>		
2U	light brown walnut <input type="checkbox"/> A	+\$114
40	dark brown walnut <input type="checkbox"/> A	+\$114
ED	aged cherry <input type="checkbox"/> A	+\$114
EK	medium red walnut <input type="checkbox"/> A	+\$114
EW	medium matte walnut <input type="checkbox"/> A	+\$114
ET	clear on ash <input type="checkbox"/> A	+\$114
EU	oak on ash <input type="checkbox"/> A	+\$114
EV	walnut on ash <input type="checkbox"/> A	+\$114
UL	natural maple <input type="checkbox"/> A	+\$114
UX	walnut on cherry <input type="checkbox"/> A	+\$114

Recut Veneer		
<i>For veneer front (A.) with 4 drawers (4)</i>		
RA	light ash <input type="checkbox"/> A	+\$0
RK	mahogany dark <input type="checkbox"/> A	+\$0
RM	mahogany <input type="checkbox"/> A	+\$0

Wood Veneer		
<i>For veneer front (A.) with 4 drawers (4)</i>		
2U	light brown walnut <input type="checkbox"/> A	+\$154
40	dark brown walnut <input type="checkbox"/> A	+\$154
ED	aged cherry <input type="checkbox"/> A	+\$154
EK	medium red walnut <input type="checkbox"/> A	+\$154
EW	medium matte walnut <input type="checkbox"/> A	+\$154
ET	clear on ash <input type="checkbox"/> A	+\$154
EU	oak on ash <input type="checkbox"/> A	+\$154
EV	walnut on ash <input type="checkbox"/> A	+\$154
UL	natural maple <input type="checkbox"/> A	+\$154
UX	walnut on cherry <input type="checkbox"/> A	+\$154

Arc Pull Freestanding Lateral File

continued

For laminate front (L.) with 2 drawers, raised height (1), 2 drawers (2), or 3 drawers (3), or 4 drawers (4)

76	light brown walnut	+\$0
8Q	folkstone grey	+\$0
91	white	+\$0
98	studio white	+\$0
CL	cool grey neutral	+\$0
HM	natural maple	+\$0
HP	light anigre	+\$0
HX	aged cherry	+\$0
HY	walnut on cherry	+\$0
LA	light ash	+\$0
LBA	clear on ash	+\$0
LBR	phantom ecru	+\$0
LBS	phantom cocoa	+\$0
LBU	medium matte walnut	+\$0
LBV	warm grey teak	+\$0
LBB	oak on ash	+\$0
LBC	walnut on ash	+\$0
LBD	dark brown walnut	+\$0
LBE	medium red walnut	+\$0
LBF	neutral twill	+\$0
LBG	sarum twill	+\$0
LBH	earthen twill	+\$0
LBJ	graphite twill	+\$0
LBK	pewter mesh	+\$0
LBL	steel mesh	+\$0
LBM	crisp linen	+\$0
LBN	classic linen	+\$0
LBP	casual linen	+\$0
LBQ	white twill	+\$0
LU	soft white	+\$0
WL	sandstone	+\$0
WN	warm grey neutral	+\$0
X1	chalk white	+\$0

Step 8. Lock

KA	keyed alike	-\$10
KC	keyed differently, chrome	+\$0
KD	keyed differently, black	+\$0

Step 9. Pull Finish

NH	brushed nickel	+\$0
NK	black nickel	+\$0

Step 10. Counterweight

		30	36	42
NO	no counterweight (must gang or anchor)	+\$0	0	0
CB	counterweight (recommended)	+\$50	95	95

Step 11. Drawer Interior

For 2 drawers, raised height (1), 2 drawers (2), 3 drawers (3), or 4 drawers (4)

1R	front-to-back filing rail	+\$0
2R	side-to-side filing rail	+\$0

For 1 flipper door with pullout shelf and 4 drawers (5)

3R	front-to-back filing rail and dividers in flipper	+\$0
4R	side-to-side filing rail and dividers in flipper	+\$0

W-Pull Freestanding Lateral File LW200.

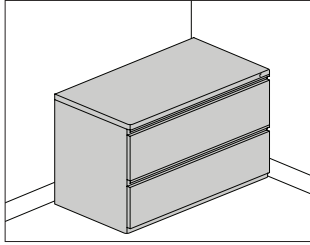

Tu® Metal Storage

Product Information

Description

This lateral file has a smooth-steel case and full-width, integrated pulls. It includes 1" leveling glides and a positive interlock system that permits only 1 drawer or pullout shelf to open at a time. Drawers can be specified with side-to-side or front-to-back filing rails to accommodate letter-, legal-, and A4-size hanging files. The pullout shelf includes 3 dividers.

Actual file depth is 19³/₈". Actual file width is 29⁵/₈", 35⁵/₈", or 41⁵/₈". Interior height of the flipper door with pullout shelf is 10¹/₄". Raised-height configuration adds 1/2" to the overall height to fill the space between the top of the file and the underside of a surface.

Notes

Base on 2 drawers, raised height option (1) aligns with base on Tu® storage towers.

2- or 3-high files that are not ganged or anchored require counterweights (option CB). When two 42"-wide, 4-high files are ganged side by side, each file requires a counterweight.

Counterweight specified with file is permanently installed. To order removable counterweight, specify file with no counterweight (option NO), and order counterweight (LG909.) separately.

Accepts Tu® add-on cushion top (LG891.).

Order optional accessories separately:

- File drawer organizer (LG901)
- Front-to-back filing rail (LG904.)
- Movable divider (9M100) - For flipper door with pullout shelf only
- Side-to-side filing rail (LG902.)

For keyed-alike locks, order lock plugs separately. See Keyed-Alike Information in Appendices.

Dimensions

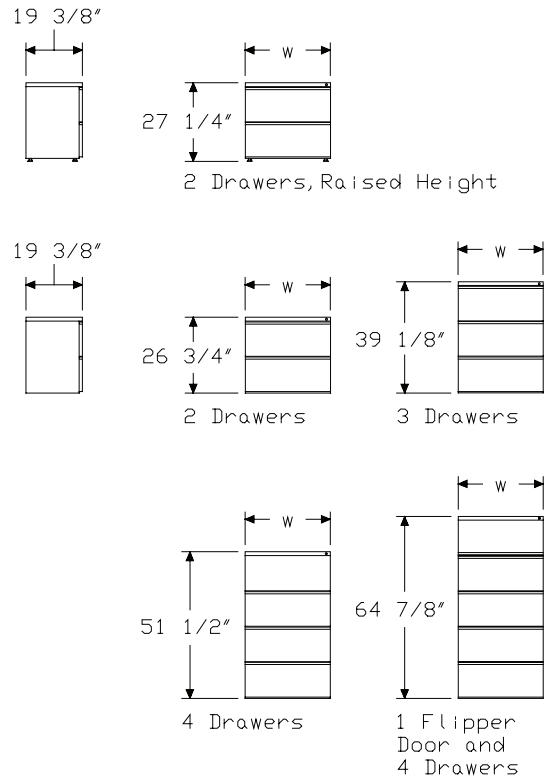

W-Pull Freestanding Lateral File

continued

Specification Information

Step 1.

LW200.

Step 2. Width

30	30" wide
36	36" wide
42	42" wide

Step 3. Configuration

1	2 drawers, raised height
2	2 drawers
3	3 drawers
4	4 drawers
5	1 flipper door with pullout shelf and 4 drawers

Prices for Steps 1-3.

	1	2	3	4	5
LW200. 30	\$937	937	1227	1514	2131
36	\$1036	1036	1355	1665	2294
42	\$1137	1137	1479	1816	2516

Step 4. Paint/Steel Type

SS	smooth paint on smooth steel	+\$0
XS	textured paint on smooth steel	+\$0

Step 5. Surface Finish

For smooth paint on smooth steel (SS)

8Q	folkstone grey	+\$0
98	studio white	+\$0
BU	black umber	+\$0
CN	metallic champagne	+\$0
EH	metallic bronze	+\$0
HF	inner tone light	+\$0
LT	light tone	+\$0
LU	soft white	+\$0
MS	metallic silver	+\$0
MT	medium tone	+\$0
SG	slate grey	+\$0
WL	sandstone	+\$0

Sand Texture Paint

For textured paint on smooth steel (XS)

91	white	+\$0
98	studio white	+\$0
BK	black	+\$0
CL	cool grey neutral	+\$0
G1	graphite	+\$0
WN	warm grey neutral	+\$0

Step 6. Lock

KA	keyed alike	-\$10
KC	keyed differently, chrome	+\$0
KD	keyed differently, black	+\$0

Step 7. Counterweight

	30	36	42	
NO	no counterweight (must gang or anchor)	+\$0	0	0
CB	counterweight (recommended)	+\$50	95	95

Step 8. Drawer Interior

For 2 drawers, raised height (1) or 2 drawers (2)

2R	side-to-side filing rail	+\$0
1R	front-to-back filing rail	+\$35

For 3 drawers (3)

2R	side-to-side filing rail	+\$0
1R	front-to-back filing rail	+\$50

For 4 drawers (4)

2R	side-to-side filing rail	+\$0
1R	front-to-back filing rail	+\$65

For 1 flipper door with pullout shelf and 4 drawers (5)

4R	side-to-side filing rail and dividers in flipper	+\$0
3R	front-to-back filing rail and dividers in flipper	+\$80

W-Pull Lateral File, with Open Shelf

LW260.

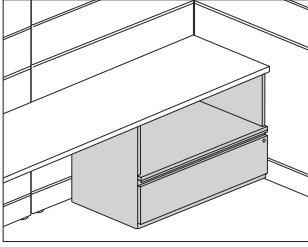

Tu® Metal Storage

Product Information

Description

This lateral file attaches below a surface and has a file drawer in the lower section with an open shelf above and no finished top. It has a smooth-steel case and recessed base with 1" leveling glides. The drawer has a full-width, integrated pull, and can be specified with side-to-side or front-to-back filing rails to accommodate letter-, legal-, and A4-size hanging files. The open shelf accommodates 12" binders.

Actual file depth is 19³/₈". Actual file width is 29⁵/₈", 35⁵/₈", or 41⁵/₈".

Interior shelf width is 27³/₄", 33³/₄", or 39³/₄".

Notes

Lateral file attaches to a 24"-deep surface only.

When lateral file is attached to a surface, a counterweight is not required.

When lateral file is attached to a surface, the surface height is 28¹/₂".

Counterweight specified with file is permanently installed. To order removable counterweight, specify file with no counterweight (option NO), and order counterweight (LG909.) separately.

Order optional accessories separately:

- File drawer organizer (LG901)
- Front-to-back filing rail (LG904.)
- Side-to-side filing rail (LG902.)
- Storage case shelf (LG940.)

For keyed-alike locks, order lock plugs separately. See Keyed-Alike Information in Appendices.

Dimensions

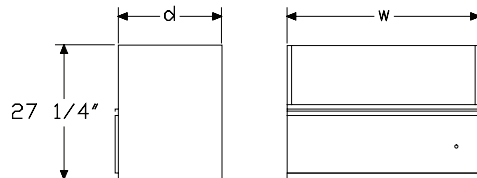

Specification Information

Step 1.

LW260.

Step 2. Width

30	30" wide
36	36" wide
42	42" wide

Prices for Steps 1-2.

LW260.30	\$921
36	\$1021
42	\$1126

Step 3. Paint/Steel Type

SS	smooth paint on smooth steel	+\$0
XS	textured paint on smooth steel	+\$0

Step 4. Surface Finish

For smooth paint on smooth steel (SS)

8Q	folkstone grey	+\$0
98	studio white	+\$0
BU	black umber	+\$0
CN	metallic champagne	+\$0
EH	metallic bronze	+\$0
HF	inner tone light	+\$0
LT	light tone	+\$0
LU	soft white	+\$0
MS	metallic silver	+\$0
MT	medium tone	+\$0
SG	slate grey	+\$0
WL	sandstone	+\$0

Sand Texture Paint

For textured paint on smooth steel (XS)

91	white	+\$0
98	studio white	+\$0
BK	black	+\$0
CL	cool grey neutral	+\$0
G1	graphite	+\$0
WN	warm grey neutral	+\$0

Step 5. Lock

KA	keyed alike	-\$10
KC	keyed differently, chrome	+\$0
KD	keyed differently, black	+\$0

W-Pull Lateral File, with Open Shelf *continued*

Step 6. Counterweight		30	36	42
NO	no counterweight (must gang or anchor)	+\$0	0	0
CB	counterweight	+\$25	48	48
Step 7. Drawer Interior				
2R	side-to-side filing rail			+\$0
1R	front-to-back filing rail			+\$17

V-Pull Freestanding Lateral File

LV200.

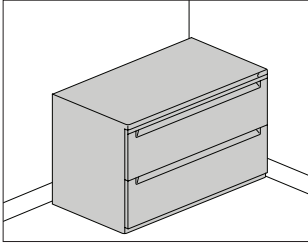

Tu® Metal Storage

Product Information

Description

This lateral file has a smooth-steel case and full-width, recessed pulls. It includes 1" leveling glides and a positive interlock system that permits only 1 drawer or pullout shelf to open at a time. Drawers can be specified with side-to-side or front-to-back filing rails to accommodate letter-, legal-, and A4-size hanging files. The pullout shelf includes 3 file dividers.

Actual file depth is 19³/₈". Actual file width is 29⁵/₈", 35⁵/₈", or 41⁵/₈".

Interior height of the flipper door with pullout shelf is 10¹/₄". Raised-height configuration adds 1/2" to overall height to fill the space between the top of the file and the underside of a surface.

Notes

Base on 2 drawers, raised height option (1) aligns with base on Tu® storage towers.

2- or 3-high files that are not ganged or anchored require counterweights (option CB). When two 42"-wide, 4-high files are ganged side by side, each file requires a counterweight.

Counterweight specified with file is permanently installed. To order removable counterweight, specify file with no counterweight (option NO), and order counterweight (LG909.) separately.

Accepts Tu® add-on cushion top (LG891.).

Order optional accessories separately:

- File drawer organizer (LG901)
- Front-to-back filing rail (LG904.)
- Movable divider (9M100) - For flipper door with pullout shelf only
- Side-to-side filing rail (LG902.)

For keyed-alike locks, order lock plugs separately. See Keyed-Alike Information in Appendices.

Dimensions

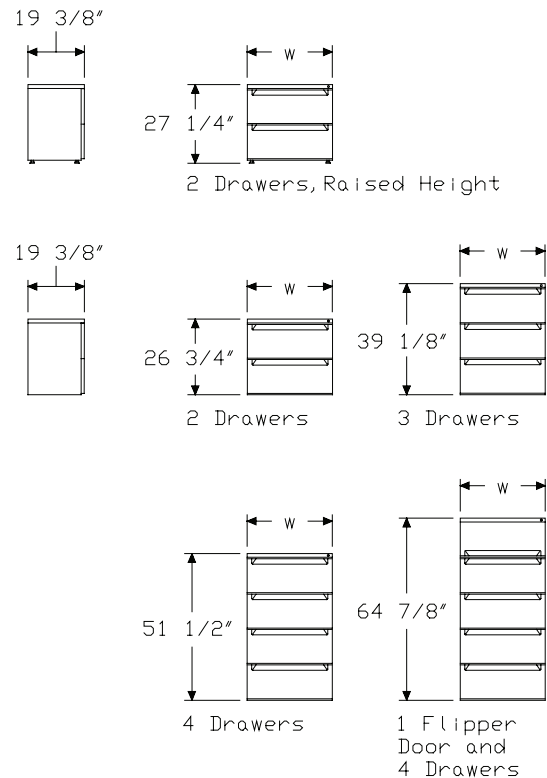

V-Pull Freestanding Lateral File

continued

Specification Information

Step 1.

LV200.

Step 2. Width

30	30" wide
36	36" wide
42	42" wide

Step 3. Configuration

1	2 drawers, raised height
2	2 drawers
3	3 drawers
4	4 drawers
5	1 flipper door with pullout shelf and 4 drawers

Prices for Steps 1-3.

	1	2	3	4	5
LV200. 30	\$943	943	1238	1564	2123
36	\$1049	1049	1367	1723	2286
42	\$1149	1149	1496	1878	2506

Step 4. Paint/Steel Type

SS	smooth paint on smooth steel	+\$0
XS	textured paint on smooth steel	+\$0

Step 5. Surface Finish

For smooth paint on smooth steel (SS)

8Q	folkstone grey	+\$0
98	studio white	+\$0
BU	black umber	+\$0
CN	metallic champagne	+\$0
EH	metallic bronze	+\$0
HF	inner tone light	+\$0
LT	light tone	+\$0
LU	soft white	+\$0
MS	metallic silver	+\$0
MT	medium tone	+\$0
SG	slate grey	+\$0
WL	sandstone	+\$0

Sand Texture Paint

For textured paint on smooth steel (XS)

91	white	+\$0
98	studio white	+\$0
BK	black	+\$0
CL	cool grey neutral	+\$0
G1	graphite	+\$0
WN	warm grey neutral	+\$0

Step 6. Lock

KA	keyed alike	-\$10
KC	keyed differently, chrome	+\$0
KD	keyed differently, black	+\$0

Step 7. Counterweight

		30	36	42
NO	no counterweight (must gang or anchor)	+\$0	0	0
CB	counterweight (recommended)	+\$50	95	95

Step 8. Drawer Interior

For 2 drawers, raised height (1) or 2 drawers (2)

2R	side-to-side filing rail	+\$0
1R	front-to-back filing rail	+\$35

For 3 drawers (3)

2R	side-to-side filing rail	+\$0
1R	front-to-back filing rail	+\$50

For 4 drawers (4)

2R	side-to-side filing rail	+\$0
1R	front-to-back filing rail	+\$65

For 1 flipper door with pullout shelf and 4 drawers (5)

4R	side-to-side filing rail and dividers in flipper	+\$0
3R	front-to-back filing rail and dividers in flipper	+\$80

V-Pull Lateral File, with Open Shelf

LV260.

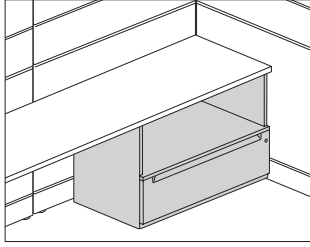

Tu® Metal Storage

Product Information

Description

This lateral file attaches below a surface and has a file drawer in the lower section with an open shelf above and no finished top. It has a smooth-steel case and recessed base with 1" leveling glides. The drawer has a full-width, recessed pull, and can be specified with side-to-side or front-to-back filing rails to accommodate letter-, legal-, and A4-size hanging files. The open shelf accommodates 12" binders.

Actual file depth is 19³/₈". Actual file width is 29⁵/₈", 35⁵/₈", or 41⁵/₈".

Interior shelf width is 27³/₄", 33³/₄", or 39³/₄".

Notes

Lateral file attaches to a 24"-deep surface only.

When lateral file is attached to a surface, a counterweight is not required.

When lateral file is attached to a surface, the surface height is 28¹/₂".

Counterweight specified with file is permanently installed. To order removable counterweight, specify file with no counterweight (option NO), and order counterweight (LG909.) separately.

Order optional accessories separately:

- File drawer organizer (LG901)
- Front-to-back filing rail (LG904.)
- Side-to-side filing rail (LG902.)
- Storage case shelf (LG940.)

For keyed-alike locks, order lock plugs separately. See Keyed-Alike Information in Appendices.

Dimensions

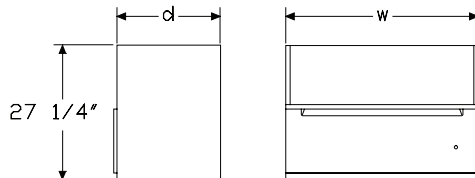

Specification Information

Step 1.

LV260.

Step 2. Width

30	30" wide
36	36" wide
42	42" wide

Prices for Steps 1-2.

LV260. 30	\$957
36	\$1062
42	\$1167

Step 3. Paint/Steel Type

SS	smooth paint on smooth steel	+\$0
XS	textured paint on smooth steel	+\$0

Step 4. Surface Finish

For smooth paint on smooth steel (SS)

8Q	folkstone grey	+\$0
98	studio white	+\$0
BU	black umber	+\$0
CN	metallic champagne	+\$0
EH	metallic bronze	+\$0
HF	inner tone light	+\$0
LT	light tone	+\$0
LU	soft white	+\$0
MS	metallic silver	+\$0
MT	medium tone	+\$0
SG	slate grey	+\$0
WL	sandstone	+\$0

Sand Texture Paint

For textured paint on smooth steel (XS)

91	white	+\$0
98	studio white	+\$0
BK	black	+\$0
CL	cool grey neutral	+\$0
G1	graphite	+\$0
WN	warm grey neutral	+\$0

Step 5. Lock

KA	keyed alike	-\$10
KC	keyed differently, chrome	+\$0
KD	keyed differently, black	+\$0

V-Pull Lateral File, with Open Shelf *continued*

Step 6. Counterweight		30	36	42
NO	no counterweight (must gang or anchor)	+\$0	0	0
CB	counterweight	+\$25	48	48
Step 7. Drawer Interior				
2R	side-to-side filing rail			+\$0
1R	front-to-back filing rail			+\$17

Bar-Pull Add-On Overfile

LK410D
LK410L

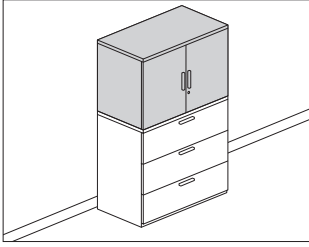

Tu® Metal Storage

Product Information

Description

This overfile is field installed to the top of a Tu® lateral file. It has hinged doors that open to 110°, a painted front, smooth-steel case and applied metal bar pull. File includes 1 shelf that is binder adjustable. Mounting hardware included.

Actual height is 26¹/₈". Actual depth is 19³/₈". Actual width is 29⁵/₈", 35⁵/₈", or 41⁵/₈" to mount to same-width lateral file.

Notes

Overfile can only be mounted to top of 2-, 3-, or 4-drawer Tu lateral file.

Attachment of overfile requires drilling through top of lateral file.

Not available with veneer front.

For best aesthetics, mount overfile to Q-pull lateral file.

Dimensions

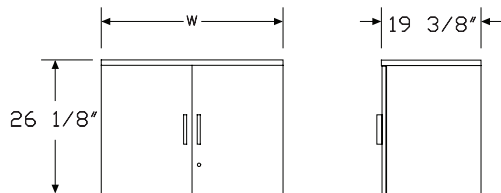

Specification Information

Step 1.

LK410

Step 2. Front Material

- D. painted metal front
- L. laminate front

Step 3. Width

- 30 30" wide
- 36 36" wide
- 42 42" wide

Prices for Steps 1-3.

LK410D.	30	\$993
	36	\$1122
	42	\$1271
LK410L.	30	\$1120
	36	\$1264
	42	\$1432

Step 4. Paint/Steel Type

- SS smooth paint on smooth steel +\$0
- XS textured paint on smooth steel +\$0

Step 5. Surface Finish

For smooth paint on smooth steel (SS)

8Q	folkstone grey	+\$0
98	studio white	+\$0
BU	black umber	+\$0
CN	metallic champagne	+\$0
EH	metallic bronze	+\$0
HF	inner tone light	+\$0
LT	light tone	+\$0
LU	soft white	+\$0
MS	metallic silver	+\$0
MT	medium tone	+\$0
SG	slate grey	+\$0
WL	sandstone	+\$0

Sand Texture Paint		
<i>For textured paint on smooth steel (XS)</i>		
91	white	+\$0
98	studio white	+\$0
BK	black	+\$0
CL	cool grey neutral	+\$0
G1	graphite	+\$0
WN	warm grey neutral	+\$0

Step 6. Front Finish		
<i>For laminate front (L.)</i>		
76	light brown walnut	+\$0
8Q	folkstone grey	+\$0
91	white	+\$0
98	studio white	+\$0
CL	cool grey neutral	+\$0
HM	natural maple	+\$0
HP	light anigre	+\$0
HX	aged cherry	+\$0
HY	walnut on cherry	+\$0
LA	light ash	+\$0
LBA	clear on ash	+\$0
LBB	oak on ash	+\$0
LBC	walnut on ash	+\$0
LBD	dark brown walnut	+\$0
LBE	medium red walnut	+\$0
LBF	neutral twill	+\$0
LBG	sarum twill	+\$0
LBH	earthen twill	+\$0
LBJ	graphite twill	+\$0
LBK	pewter mesh	+\$0
LBL	steel mesh	+\$0
LBM	crisp linen	+\$0
LBN	classic linen	+\$0
LBP	casual linen	+\$0
LBQ	white twill	+\$0
LBR	phantom ecru	+\$0
LBS	phantom cocoa	+\$0
LBU	medium matte walnut	+\$0
LBV	warm grey teak	+\$0
LU	soft white	+\$0
WL	sandstone	+\$0
WN	warm grey neutral	+\$0

Step 7. Lock		
KA	keyed alike	-\$10
KC	keyed differently, chrome	+\$0
KD	keyed differently, black	+\$0

Step 8. Pull Finish		
Metallic Paint		
CN	metallic champagne	+\$0
MS	metallic silver	+\$0

Sand Texture Paint		
79	green apple	+\$15
BK	black	+\$0
MY3	yellow oxide	+\$15
RO	red	+\$15
TRQ	turquoise	+\$15

Smooth Paint		
8Q	folkstone grey	+\$0
91	white	+\$0
98	studio white	+\$0
G1	graphite	+\$0
WL	sandstone	+\$0

Arc Pull Add-On Overfile

LQ410D
LQ410L

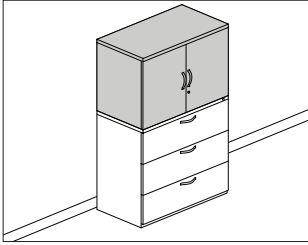

Tu® Metal Storage

Product Information

Description

This overfile is field installed to the top of a Tu® lateral file. It has hinged doors that open to 110°, a painted front, smooth-steel case and applied metal arc pull. File includes 1 shelf that is binder adjustable. Mounting hardware included.

Actual height is 26 1/8". Actual depth is 19 3/8". Actual width is 29 1/2", 35 1/2", or 41 1/2" to mount to same-width lateral file.

Notes

Pull design conforms to guidelines of Americans with Disabilities Act (ADA).

Overfile can only be mounted to top of 2-, 3-, or 4-drawer Tu lateral file.

Attachment of overfile requires drilling through top of lateral file.

Not available with veneer front.

For best aesthetics, mount overfile to arc pull lateral file.

Dimensions

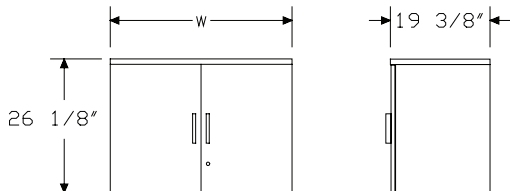

Specification Information

Step 1.

LQ410

Step 2. Front Material

- D. painted metal front
- L. laminate front

Step 3. Width

- 30 30" wide
- 36 36" wide
- 42 42" wide

Prices for Steps 1-3.

LQ410D. 30	\$993
36	\$1122
42	\$1271
<hr/>	
LQ410L. 30	\$1120
36	\$1264
42	\$1432

Step 4. Paint/Steel Type

- SS** smooth paint on smooth steel +\$0
- XS** textured paint on smooth steel +\$0

Step 5. Surface Finish

For smooth paint on smooth steel (SS)

8Q	folkstone grey	+\$0
98	studio white	+\$0
BU	black umber	+\$0
CN	metallic champagne	+\$0
EH	metallic bronze	+\$0
HF	inner tone light	+\$0
LT	light tone	+\$0
LU	soft white	+\$0
MS	metallic silver	+\$0
MT	medium tone	+\$0
SG	slate grey	+\$0
WL	sandstone	+\$0

Arc Pull Add-On Overfile *continued*

Sand Texture Paint		
<i>For textured paint on smooth steel (XS)</i>		
91	white	+\$0
98	studio white	+\$0
BK	black	+\$0
CL	cool grey neutral	+\$0
G1	graphite	+\$0
WN	warm grey neutral	+\$0
Step 6. Lock		
KA	keyed alike	-\$10
KC	keyed differently, chrome	+\$0
KD	keyed differently, black	+\$0
Step 7. Pull Finish		
NH	brushed nickel	+\$0
NK	black nickel	+\$0

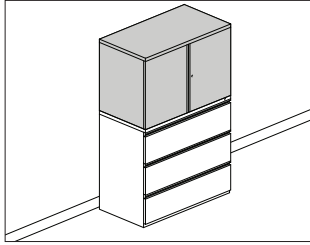

Tu® Metal Storage

Product Information

Description
 This overfile is field installed to the top of a Tu® lateral file. It has hinged doors that open to 110°, a smooth-steel case and full-width integrated pull. File includes 1 shelf that is binder adjustable. Mounting hardware included.
 Actual height is 26 1/8". Actual depth is 19 3/8". Actual width is 29 5/8", 35 5/8", or 41 5/8" to mount to same-width lateral file.

Notes

Overfile can only be mounted to top of 2-, 3-, or 4-drawer Tu lateral file.
 Attachment of overfile requires drilling through top of lateral file.
 For best aesthetics, mount overfile to W-pull lateral file.

Dimensions

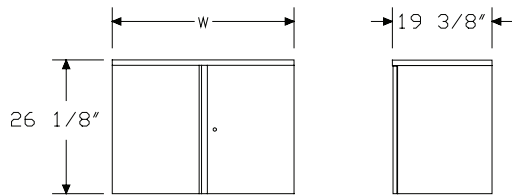

Specification Information

Step 1.

LW410.

Step 2. Width

30	30" wide
36	36" wide
42	42" wide

Prices for Steps 1-2.

LW410. 30	\$1000
36	\$1125
42	\$1275

Step 3. Paint/Steel Type

SS	smooth paint on smooth steel	+\$0
XS	textured paint on smooth steel	+\$0

Step 4. Surface Finish

For smooth paint on smooth steel (SS)

8Q	folkstone grey	+\$0
98	studio white	+\$0
BU	black umber	+\$0
CN	metallic champagne	+\$0
EH	metallic bronze	+\$0
HF	inner tone light	+\$0
LT	light tone	+\$0
LU	soft white	+\$0
MS	metallic silver	+\$0
MT	medium tone	+\$0
SG	slate grey	+\$0
WL	sandstone	+\$0

Sand Texture Paint

For textured paint on smooth steel (XS)

91	white	+\$0
98	studio white	+\$0
BK	black	+\$0
CL	cool grey neutral	+\$0
G1	graphite	+\$0
WN	warm grey neutral	+\$0

Step 5. Lock

KA	keyed alike	-\$10
KC	keyed differently, chrome	+\$0
KD	keyed differently, black	+\$0

V-Pull Add-On Overfile

LV410.

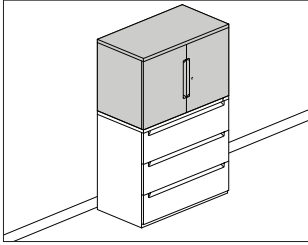

Product Information

Description

This overfile is field installed to the top of a Tu® lateral file. It has hinged doors that open to 110°, a smooth-steel case and full-width recessed pull. File includes 1 shelf that is binder adjustable. Mounting hardware included.

Actual height is 26¹/₈". Actual depth is 19³/₈". Actual width is 29⁷/₈", 35⁵/₈", or 41⁵/₈" to mount to same-width lateral file.

Notes

Overfile can only be mounted to top of 2-, 3-, or 4-drawer Tu lateral file.

Attachment of overfile requires drilling through top of lateral file.

For best aesthetics, mount overfile to V-pull lateral file.

Dimensions

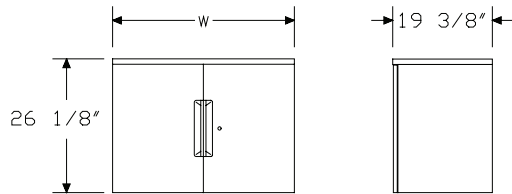

Specification Information

Step 1.

LV410.

Step 2. Width

30	30" wide
36	36" wide
42	42" wide

Prices for Steps 1-2.

LV410. 30	\$998
36	\$1122
42	\$1271

Step 3. Paint/Steel Type

SS	smooth paint on smooth steel	+\$0
XS	textured paint on smooth steel	+\$0

Step 4. Surface Finish

For smooth paint on smooth steel (SS)

8Q	folkstone grey	+\$0
98	studio white	+\$0
BU	black umber	+\$0
CN	metallic champagne	+\$0
EH	metallic bronze	+\$0
HF	inner tone light	+\$0
LT	light tone	+\$0
LU	soft white	+\$0
MS	metallic silver	+\$0
MT	medium tone	+\$0
SG	slate grey	+\$0
WL	sandstone	+\$0

Sand Texture Paint

For textured paint on smooth steel (XS)

91	white	+\$0
98	studio white	+\$0
BK	black	+\$0
CL	cool grey neutral	+\$0
G1	graphite	+\$0
WN	warm grey neutral	+\$0

Step 5. Lock

KA	keyed alike	-\$10
KC	keyed differently, chrome	+\$0
KD	keyed differently, black	+\$0

Tu® File Top

LTPL-
LTPV-

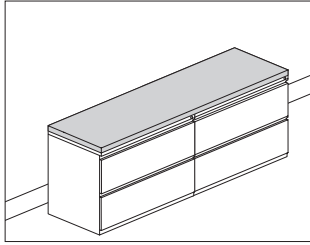

Tu® Metal Storage

Product Information

Description

This file top attaches to a combination of freestanding Tu® lateral files or storage cases with 20" depths. It has a laminate top with thermoplastic edge or a veneer top and edge.

Notes

Dimensions listed are nominal. Actual dimensions are calculated to work with Tu files and cases. Refer to planning documents on Kiosk/One Stop for exact dimensions and additional details.

Additional sizes and open-line laminates available through Vary Easy® Exact Size Top Price Book (specIT edition only).

Dimensions

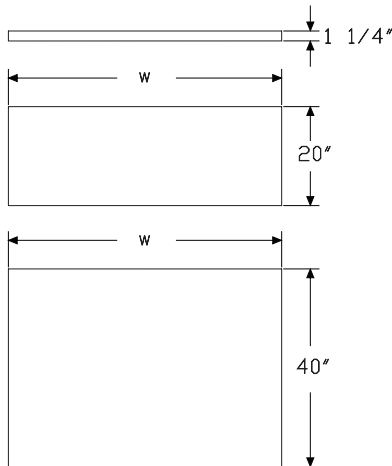

Specification Information

Step 1.

LTP A

Step 2. Top/Edge Material

L- laminate top with thermoplastic edge A

V- veneer top with veneer edge A

Step 3. Width

For laminate top with thermoplastic edge (L-)

- 030 30" wide A
- 036 36" wide A
- 042 42" wide A
- 060 60" wide A
- 072 72" wide A
- 084 84" wide A
- 090 90" wide A
- 108 108" wide A

For veneer top with veneer edge (V-)

- 030 30" wide A
- 036 36" wide A
- 042 42" wide A
- 060 60" wide A
- 072 72" wide A
- 084 84" wide A
- 090 90" wide A

Step 4. Depth

- 20 20" deep A
- 40 40" deep A

Prices for Steps 1-4.

		20	40
LTPL-	030	\$229	470
	036	\$251	563
	042	\$293	654
	060	\$428	958
	072	\$514	1149
	084	\$598	1333
	090	\$642	1437
	108	\$769	1724

LTPV- 030	\$522	906
036	\$584	957
042	\$647	1083
060	\$848	1482
072	\$979	1739
084	\$1106	1995
090	\$1168	2118

Step 5. Top/Edge Finish

Solid-Color Laminate Top/Thermoplastic Edge

For laminate top with thermoplastic edge (L-)

8Q folkstone grey A		+\$0
91 white A		+\$0
98 studio white		+\$0
CL cool grey neutral A		+\$0
HF inner tone light A		+\$0
HT inner tone A		+\$0
LT light tone A		+\$0
LU soft white A		+\$0
WL sandstone A		+\$0
WN warm grey neutral A		+\$0

Linen Laminate

For laminate top with thermoplastic edge (L-)

LBM crisp linen		+\$0
LBN classic linen		+\$0
LBP casual linen		+\$0

Mesh Laminate

For laminate top with thermoplastic edge (L-)

LBK pewter mesh		+\$0
LBL steel mesh		+\$0

Twill Laminate

For laminate top with thermoplastic edge (L-)

LBF neutral twill		+\$0
LBG sarum twill		+\$0
LBH earthen twill		+\$0
LBJ graphite twill		+\$0
LBQ white twill		+\$0

Wood-Grain Laminate Top/Thermoplastic Edge

For laminate top with thermoplastic edge (L-)

HM natural maple A		+\$0
HP light anigre A		+\$0
LA light ash A		+\$0
LBA clear on ash		+\$0
LBB oak on ash		+\$0
LBC walnut on ash		+\$0
LBD dark brown walnut		+\$0
LBR phantom ecru		+\$0
LBS phantom cocoa		+\$0
LBU medium matte walnut		+\$0
LBV warm grey teak		+\$0
LBE medium red walnut		+\$0
LM mahogany A		+\$0
76 light brown walnut A		+\$0
HX aged cherry A		+\$0
HY walnut on cherry A		+\$0

Zephyr Laminate Top/Thermoplastic Edge

For laminate top with thermoplastic edge (L-)

28 canyon A		+\$0
29 misted A		+\$0

Recut Veneer

For veneer top with veneer edge (V-)

RA light ash A		+\$0
RK mahogany dark A		+\$0
RM mahogany A		+\$0

Wood Veneer

For veneer top with veneer edge (V-)

2U light brown walnut A		+\$140
40 dark brown walnut A		+\$140
ED aged cherry A		+\$140
EK medium red walnut A		+\$140
EW medium matte walnut A		+\$140
ET clear on ash A		+\$140
EU oak on ash A		+\$140
EV walnut on ash A		+\$140
UL natural maple A		+\$140
UX walnut on cherry A		+\$140

Lateral File Add-On Cushion Top LG891.

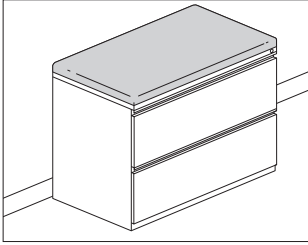

Tu® Metal Storage

Product Information

Description

This 1"- or 2"-high cushion top is retrofit to a lateral file with a flat metal top and provides temporary guest seating. Hook-and-loop fastener strips are included to attach cushion top to flat metal top.

Notes

Cushion top accepts Customer's Own Material (COM). Yardage is estimated for nondirectional, 54"-wide fabrics. When ordering more than 1 cushion, round up total yardage requirement to next whole yard of fabric.

Width—Yardage

30"—1.05

36"—1.22

42"—1.40

For information on multiple quantities or directional fabrics, contact COM Department. See Order Information in Appendices.

Dimensions

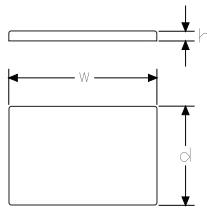

Specification Information

Step 1.

LG891.

Step 2. Height

1 1" high

2 2" high

Step 3. Width

30 30" wide

36 36" wide

42 42" wide

Prices for Steps 1-3.

	30	36	42
LG891. 1	\$246	314	331
2	\$308	351	386

Step 4. Cushion Top Fabric

See application chart and textiles list for fabric usage and numbers.

First 2 digits of number indicate fabric line; remaining digit(s) indicate fabric color.

Price Category 1	+\$0
Price Category 2	+\$102
Price Category 3	+\$123
Price Category 4	+\$151
Price Category 7 A	+\$206
Price Category 9	+\$1425
Price Category B	+\$71
Price Category E	+\$150
Price Category G	+\$251
Price Category H	+\$305

Front-to-Back Filing Rail, Tu®
Lateral File

LG904.

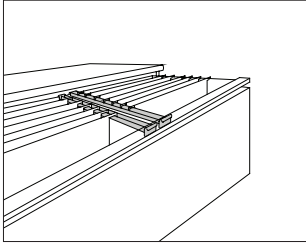

Product Information

Description

These black umber filing rails hold letter-, legal-, and A4-size hanging folders for front-to-back filing in a Tu® or Quadrant® lateral file drawer. Package contains 2 rails.

Notes

2 rails accommodate 1 file drawer.

Dimensions

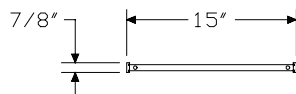

Specification Information

Step 1.

LG904.

Step 2. Width

- 30** for 30"-wide drawers
- 36** for 36"-wide drawers
- 42** for 42"-wide drawers

Prices for Steps 1-2.

LG904. 30	\$40
36	\$40
42	\$40

File Drawer Organizer

LG901

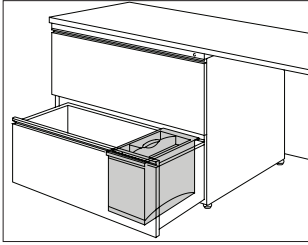

Tu® Metal Storage

Product Information

Description

This 2-sectioned organizer fits into any file drawer arranged for letter-size filing. The removable top section stores computer disks and other small items. The bottom section stores larger items or can be divided into 3 compartments; it includes 2 vertical dividers. Finish is black umber.

Dimensions

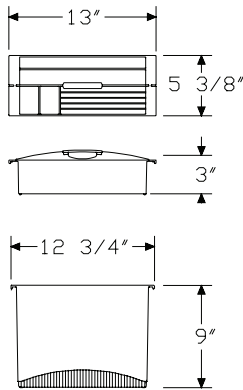

Specification Information

Step 1.

LG901

\$84

Side-to-Side Filing Rail, Tu®
Lateral File

LG902.

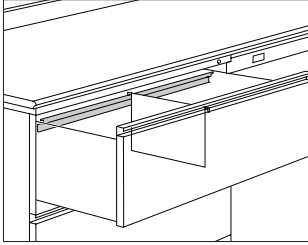

Product Information

Description

This filing rail holds letter- or legal-size hanging folders for side-to-side filing in a Tu® or Quadrant® lateral file drawer. Available in 3 sizes: 26½"-wide rail for 30"-wide drawer, 32½"-wide rail for 36"-wide drawer, and 38½"-wide rail for 42"-wide drawer. Package contains 1 rail.

Notes

2 rails are needed per drawer.

Side-to-side filing rail cannot be used in Meridian Stackable™ lateral file drawers, Meridian Stackable Storage™ cabinet bottom module, or Meridian lateral storage tower.

Dimensions

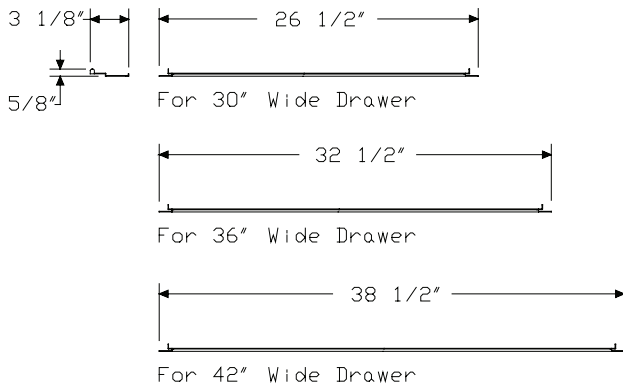

Specification Information

Step 1.

LG902.

Step 2. Width

- 30** for 30"-wide drawers
- 36** for 36"-wide drawers
- 42** for 42"-wide drawers

Prices for Steps 1-2.

LG902. 30	\$27
36	\$27
42	\$27

Movable Divider, Meridian®,
 Quadrant® or Tu®

9M100
 9M300

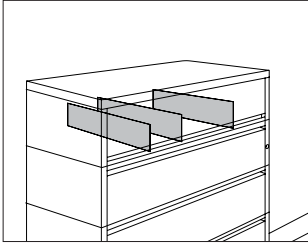

Tu® Metal Storage

Product Information

Description

This adjustable metal divider fits into slots of an 18"- or 20"-deep Meridian® Stackable™ lateral file drawer. The 18"-deep divider also fits into a pullout shelf's slots on a Tu® or Quadrant® 5-high lateral file. Finish is black umber.

Dimensions

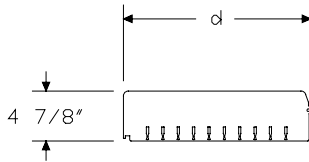

Specification Information

Step 1.

9M

Step 2. Quantity

100 1 divider
300 3 dividers

Step 3. Depth

18 for Meridian® 18"-deep Stackable™ lateral file modules or
 Quadrant® 20" deep flipper door with pullout shelf
20 for Meridian® 20" deep Stackable™ lateral file modules

Prices for Steps 1-3.

9M100	18	\$16
	20	\$16
9M300	18	\$37
	20	\$37

Counterweight, Tu® Lateral File LG909.

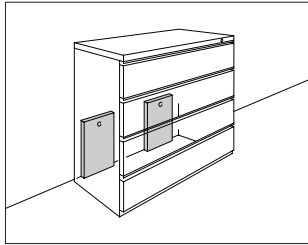

Product Information

Description

This counterweight is field installed to the inside back of a Tu® or Quadrant® freestanding lateral file. It provides stability when file is not anchored or ganged to another file. Counterweight for 30" wide file includes 2 plates, counterweight for 36"- or 42"-wide file includes 4 plates. Mounting hardware included.

Dimensions

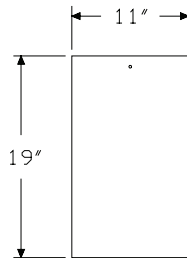

Specification Information

Step 1.

LG909.

Step 2. Width

- 1** for 30"-wide file
- 2** for 36"- or 42"- wide file

Prices for Steps 1-2.

LG909. 1	\$112
2	\$207

Label Holders-Snap In and Adhesive

9LH5H
9LH7H

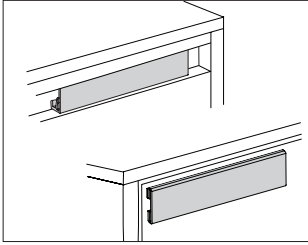

Tu® Metal Storage

Product Information

Description

These label holders snap in place for standard pull file drawers or attach with adhesive onto drawers with other pull styles. Package contains 25 of the specified style. Labels included.

Dimensions

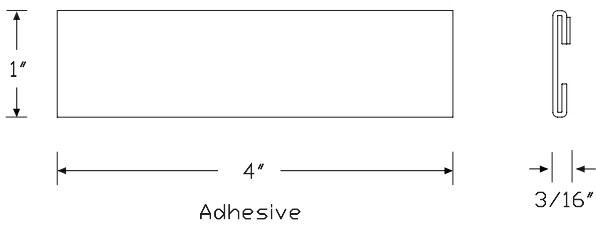
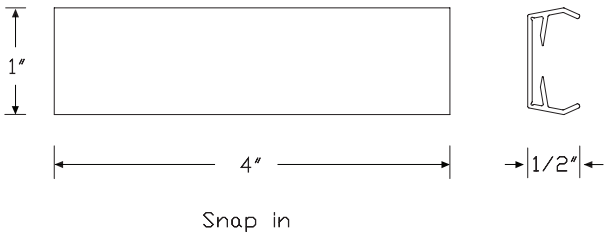

Specification Information

Step 1.

9LH A

Step 2. Style

5HV snap in A

7HT adhesive A

Prices for Steps 1-2.

9LH5HV	\$21
9LH7HT	\$19

Bar-Pull Storage Tower

LK300D
LK300L
LK310D
LK310L

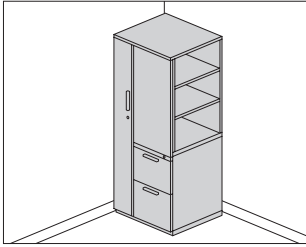

Product Information

Description

This freestanding storage tower has a wardrobe on 1 side and the option of a storage case or side-facing bookcase on the other side. Pedestal is located opposite of wardrobe. The tower has a smooth-steel case, painted metal or laminate fronts, applied metal bar pulls, and recessed base with 1" leveling glides. Units with laminate fronts will include a metal top and a metal fascia piece (where lock is located). Available in 9 heights.

Actual tower depth is 23 1/4". Actual tower width is 23 7/8".

9"-wide wardrobe is available with a coat hook or coat rod.

15"-wide storage case is locking and has 1 or 2 adjustable shelves.

Shelves adjust in 1 1/4" increments, starting 7" from the bottom of the storage case.

Side-facing bookcase is 14 1/2" deep and 23 1/4" wide. It includes 1 or 2 adjustable shelves that adjust in 1 1/4" increments.

Pedestal is locking, with one lock securing all drawers. It includes a positive interlock system that permits only 1 drawer to open at a time.

Drawers are available in a variety of box and file drawer configurations.

Box drawers are available with full-extension or 3/4-extension slides and include a drawer divider, utility tray or storage organizer. File drawers have full-extension slides and hold letter-size front-to-back hanging files. Each file drawer includes file converters for letter-, legal- and A4-size side-to-side hanging files.

Notes

The following chart shows the number of adjustable shelves in each storage case/side-facing bookcase based on tower height:

Height—Shelves

- 46" h (45" actual)—1 shelf
- 53" h (52 1/2" actual)—1 shelf
- 54" h (53 1/2" actual)—1 shelf
- 57" h (56" actual)—1 shelf
- 62" h (61 1/2" actual)—1 shelf
- 65" h (64 1/2" actual)—2 shelves
- 67" h (66 1/2" actual)—2 shelves
- 68" h (67" actual)—2 shelves
- 70" h (69 1/2" actual)—2 shelves

Dimensional illustrations do not include all possible configurations.

Order optional accessories separately:

- File compressor (LG908)
- File drawer organizer (LG901)
- Pedestal stationery divider (LG905)
- Storage organizer (LG910)

Storage organizer includes a hanging file holder, utility tray (pencil tray) and 2 containers. The storage organizer frame color matches the drawer interior; file holder and containers are 91 white; utility tray is black.

All locks in tower are factory installed and are keyed alike within the tower. For specific numbering choices, specify KA and order lock plugs separately. See Keyed-Alike Information in appendices.

Dimensions

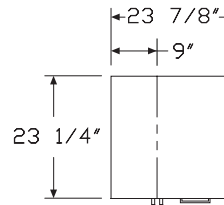

Bar-Pull Storage Tower *continued*

Tu® Metal Storage

Specification Information

Step 1.

LK3

Step 2. Storage Configuration

00 storage case

10 side-facing bookcase

Step 3. Front Material

D. painted metal

L. laminate front

Step 4. Height

46 46" high

53 53" high

54 54" high

57 57" high

62 62" high

65 65" high

67 67" high

68 68" high

70 70" high

Step 5. Wardrobe Location

L wardrobe left

R wardrobe right

Step 6. Drawer Configuration

For 46" high (46), 53" high (53), 54" high (54), or 57" high (57)

R file/file

S box/box/file

For 62" high (62), 65" high (65), 67" high (67), 68" high (68), or 70" high (70)

R file/file

S box/box/file

T file/file/file

V box/box/file/file

Prices for Steps 1-6.

		R	S	T	V
LK300D.	46 L	\$2436	2439	—	—
	R	\$2436	2439	—	—
	53 L	\$2475	2479	—	—
	R	\$2475	2479	—	—

	54 L	\$2501	2503	—	—
	R	\$2501	2503	—	—
	57 L	\$2525	2529	—	—
	R	\$2525	2529	—	—
	62 L	\$2670	2673	2922	2929
	R	\$2670	2673	2922	2929
	65 L	\$2701	2704	2955	2964
	R	\$2701	2704	2955	2964
	67 L	\$2732	2737	2990	2999
	R	\$2732	2737	2990	2999
	68 L	\$2610	2613	2856	2864
	R	\$2610	2613	2856	2864
	70 L	\$2765	2768	3027	3035
	R	\$2765	2768	3027	3035

		R	S	T	V
LK300L.	46 L	\$2747	2749	—	—
	R	\$2747	2749	—	—
	53 L	\$2790	2795	—	—
	R	\$2790	2795	—	—
	54 L	\$2819	2821	—	—
	R	\$2819	2821	—	—
	57 L	\$2846	2851	—	—
	R	\$2846	2851	—	—
	62 L	\$3011	3013	3293	3302
	R	\$3011	3013	3293	3302
	65 L	\$3045	3048	3332	3341
	R	\$3045	3048	3332	3341
	67 L	\$3079	3085	3370	3381
	R	\$3079	3085	3370	3381
	68 L	\$2942	2945	3220	3229
	R	\$2942	2945	3220	3229
	70 L	\$3117	3120	3412	3421
	R	\$3117	3120	3412	3421

		R	S	T	V
LK310D.	46 L	\$2550	2553	—	—
	R	\$2550	2553	—	—
	53 L	\$2460	2593	—	—
	R	\$2460	2593	—	—
	54 L	\$2479	2616	—	—
	R	\$2479	2616	—	—
	57 L	\$2637	2642	—	—
	R	\$2637	2642	—	—
	62 L	\$2789	2791	3051	3058
	R	\$2789	2791	3051	3058

Bar-Pull Storage Tower *continued*

65 L	\$2820	2824	3086	3094	
R	\$2820	2824	3086	3094	
67 L	\$2852	2856	3120	3129	
R	\$2852	2856	3120	3129	
68 L	\$2724	2727	2981	2989	
R	\$2724	2727	2981	2989	
70 L	\$2885	2889	3155	3164	
R	\$2885	2889	3155	3164	
		R	S	T	V
LK310L. 46 L	\$2873	2877	—	—	
R	\$2873	2877	—	—	
53 L	\$2772	2923	—	—	
R	\$2772	2923	—	—	
54 L	\$2795	2948	—	—	
R	\$2795	2948	—	—	
57 L	\$2973	2978	—	—	
R	\$2973	2978	—	—	
62 L	\$3144	3147	3439	3446	
R	\$3144	3147	3439	3446	
65 L	\$3179	3182	3477	3487	
R	\$3179	3182	3477	3487	
67 L	\$3214	3220	3517	3528	
R	\$3214	3220	3517	3528	
68 L	\$3070	3074	3359	3369	
R	\$3070	3074	3359	3369	
70 L	\$3252	3256	3556	3566	
R	\$3252	3256	3556	3566	

Step 7. Slides

For file/file (R) or file/file/file (T)

SB	full-extension ball-bearing	+\$0
-----------	-----------------------------	------

For box/box/file (S) or box/box/file/file (V)

SR	3/4-extension roller slides on box drawer, full-extension ball bearing on file drawer	+\$0
SB	full-extension ball-bearing	+\$0
SB	full-extension ball-bearing	+\$50

Step 8. Paint/Steel Type

SS	smooth paint on smooth steel	+\$0
XS	textured paint on smooth steel	+\$0

Step 9. Surface Finish

For smooth paint on smooth steel (SS)

8Q	folkstone grey	+\$0
98	studio white	+\$0
BU	black umber	+\$0
CN	metallic champagne	+\$0
EH	metallic bronze	+\$0
HF	inner tone light	+\$0
LT	light tone	+\$0
LU	soft white	+\$0
MS	metallic silver	+\$0
MT	medium tone	+\$0
SG	slate grey	+\$0
WL	sandstone	+\$0

Sand Texture Paint

For textured paint on smooth steel (XS)

91	white	+\$0
98	studio white	+\$0
BK	black	+\$0
CL	cool grey neutral	+\$0
G1	graphite	+\$0
WN	warm grey neutral	+\$0

Bar-Pull Storage Tower *continued*

Tu® Metal Storage

Step 10. Front Finish

For laminate front (L.)

76	light brown walnut	+\$0
8Q	folkstone grey	+\$0
91	white	+\$0
98	studio white	+\$0
CL	cool grey neutral	+\$0
HM	natural maple	+\$0
HP	light anigre	+\$0
HX	aged cherry	+\$0
HY	walnut on cherry	+\$0
LA	light ash	+\$0
LBA	clear on ash	+\$0
LBB	oak on ash	+\$0
LBC	walnut on ash	+\$0
LBD	dark brown walnut	+\$0
LBE	medium red walnut	+\$0
LBF	neutral twill	+\$0
LBG	sarum twill	+\$0
LBH	earthen twill	+\$0
LBJ	graphite twill	+\$0
LBK	pewter mesh	+\$0
LBL	steel mesh	+\$0
LBM	crisp linen	+\$0
LBN	classic linen	+\$0
LBP	casual linen	+\$0
LBQ	white twill	+\$0
LBR	phantom ecru	+\$0
LBS	phantom cocoa	+\$0
LBU	medium matte walnut	+\$0
LBV	warm grey teak	+\$0
LU	soft white	+\$0
WL	sandstone	+\$0
WN	warm grey neutral	+\$0

Step 11. Lock

KA	keyed alike	-\$10
KC	keyed differently, chrome	+\$0
KD	keyed differently, black	+\$0

Step 12. Pull Finish

Metallic Paint

CN	metallic champagne	+\$0
MS	metallic silver	+\$0

Sand Texture Paint

79	green apple	+\$15
BK	black	+\$0
MY3	yellow oxide	+\$15
RO	red	+\$15
TRQ	turquoise	+\$15

Smooth Paint

8Q	folkstone grey	+\$0
91	white	+\$0
98	studio white	+\$0
G1	graphite	+\$0
WL	sandstone	+\$0
XX	no pull	+\$0

Step 13. Wardrobe Interior

CH	coat hook	+\$0
CR	coat rod	+\$15

Step 14. Drawer Interior

For file/file (R) or file/file/file (T)

NN	none	+\$0
1M	2 file converters in each file drawer	+\$25
C51	storage organizer including hanging file holder bin, utility tray and two containers A	+\$120

For box/box/file (S) or box/box/file/file (V)

NN	none	+\$0
2M	drawer divider in box drawers, 2 file converters in file drawer	+\$25
3M	drawer divider in one box drawer, pencil tray in one box drawer, 2 file converters in file drawer	+\$25
C51	storage organizer including hanging file holder bin, utility tray and two containers A	+\$120

Arc Pull Storage Tower

LQ300D
LQ300L
LQ310D
LQ310L

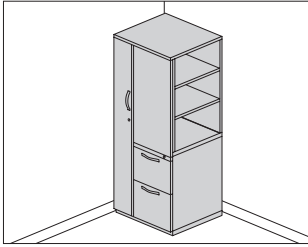

Product Information

Description

This freestanding storage tower has a wardrobe on 1 side and the option of a storage case or side-facing bookcase on the other side. Pedestal is located opposite of wardrobe. The tower has a smooth-steel case, painted metal or laminate fronts, applied metal arc pulls, and recessed base with 1" leveling glides. Units with laminate fronts will include a metal top and a metal fascia piece (where lock is located). Available in 9 heights.

Actual tower depth is 23¹/₄". Actual tower width is 23⁷/₈".

9"-wide wardrobe is available with a coat hook or coat rod.

15"-wide storage case is locking and has 1 or 2 adjustable shelves.

Shelves adjust in 1¹/₄" increments, starting 7" from the bottom of the storage case.

Side-facing bookcase is 14¹/₂" deep and 23¹/₄" wide. It includes 1 or 2 adjustable shelves that adjust in 1¹/₄" increments.

Pedestal is locking, with one lock securing all drawers. It includes a positive interlock system that permits only 1 drawer to open at a time. Drawers are available in a variety of box and file drawer configurations. Box drawers are available with full-extension or 3/4-extension slides and include a drawer divider, utility tray or storage organizer. File drawers have full-extension slides and hold letter-size front-to-back hanging files. Each file drawer includes file converters for letter-, legal- and A4-size side-to-side hanging files.

Notes

Pull design conforms to guidelines of Americans with Disabilities Act (ADA).

The following chart shows the number of adjustable shelves in each storage case/side-facing bookcase based on tower height:

Height—Shelves

- 46" h (45" actual)—1 shelf
- 53" h (52¹/₂" actual)—1 shelf
- 54" h (53¹/₂" actual)—1 shelf
- 57" h (56" actual)—1 shelf
- 62" h (61¹/₂" actual)—1 shelf
- 65" h (64¹/₂" actual)—2 shelves
- 67" h (66¹/₂" actual)—2 shelves
- 68" h (67" actual)—2 shelves
- 70" h (69¹/₂" actual)—2 shelves

Dimensional illustrations do not include all possible configurations.

Order optional accessories separately:

- File compressor (LG908)
- File drawer organizer (LG901)
- Pedestal stationery divider (LG905)
- Storage organizer (LG910)

Storage organizer includes a hanging file holder, utility tray (pencil tray) and 2 containers. The storage organizer frame color matches the drawer interior; file holder and containers are 91 white; utility tray is black.

All locks in tower are factory installed and are keyed alike within the tower. For specific numbering choices, specify KA and order lock plugs separately. See Keyed-Alike Information in appendices.

Dimensions

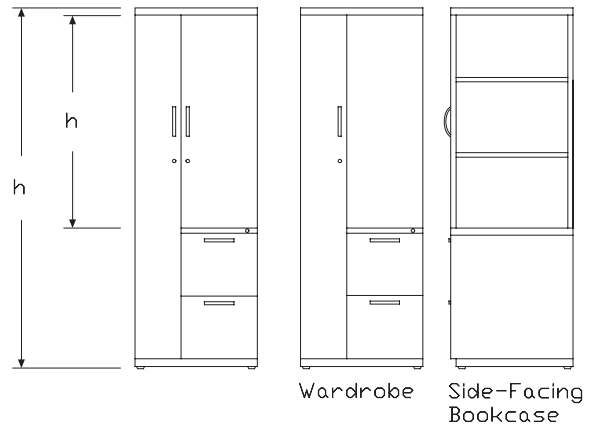
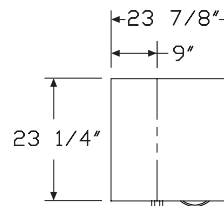

Arc Pull Storage Tower *continued*

Tu® Metal Storage

Specification Information

Step 1.

LQ3

Step 2. Storage Configuration

00 storage case

10 side-facing bookcase

Step 3. Front Material

D. painted metal

L. laminate front

Step 4. Height

46 46" high

53 53" high

54 54" high

57 57" high

62 62" high

65 65" high

67 67" high

68 68" high

70 70" high

Step 5. Wardrobe Location

L wardrobe left

R wardrobe right

Step 6. Drawer Configuration

For 46" high (46), 53" high (53), 54" high (54), or 57" high (57)

R file/file

S box/box/file

For 62" high (62), 65" high (65), 67" high (67), 68" high (68), or 70" high (70)

R file/file

S box/box/file

T file/file/file

V box/box/file/file

Prices for Steps 1-6.

		R	S	T	V
LQ300D.	46 L	\$2436	2439	—	—
	R	\$2436	2439	—	—
	53 L	\$2475	2479	—	—
	R	\$2475	2479	—	—

	54 L	\$2501	2503	—	—
	R	\$2501	2503	—	—
	57 L	\$2525	2529	—	—
	R	\$2525	2529	—	—
	62 L	\$2670	2673	2922	2929
	R	\$2670	2673	2922	2929
	65 L	\$2701	2704	2955	2964
	R	\$2701	2704	2955	2964
	67 L	\$2732	2737	2990	2999
	R	\$2732	2737	2990	2999
	68 L	\$2610	2613	2856	2864
	R	\$2610	2613	2856	2864
	70 L	\$2765	2768	3027	3035
	R	\$2765	2768	3027	3035

		R	S	T	V
LQ300L.	46 L	\$2747	2749	—	—
	R	\$2747	2749	—	—
	53 L	\$2790	2795	—	—
	R	\$2790	2795	—	—
	54 L	\$2819	2821	—	—
	R	\$2819	2821	—	—
	57 L	\$2846	2851	—	—
	R	\$2846	2851	—	—
	62 L	\$3011	3013	3293	3302
	R	\$3011	3013	3293	3302
	65 L	\$3045	3048	3332	3341
	R	\$3045	3048	3332	3341
	67 L	\$3079	3085	3370	3381
	R	\$3079	3085	3370	3381
	68 L	\$2942	2945	3220	3229
	R	\$2942	2945	3220	3229
	70 L	\$3117	3120	3412	3421
	R	\$3117	3120	3412	3421

		R	S	T	V
LQ310D.	46 L	\$2550	2553	—	—
	R	\$2550	2553	—	—
	53 L	\$2459	2592	—	—
	R	\$2459	2592	—	—
	54 L	\$2479	2615	—	—
	R	\$2479	2615	—	—
	57 L	\$2637	2641	—	—
	R	\$2637	2641	—	—
	62 L	\$2789	2791	3051	3057
	R	\$2789	2791	3051	3057

Arc Pull Storage Tower *continued*

65 L	\$2820	2823	3085	3094	
R	\$2820	2823	3085	3094	
67 L	\$2851	2856	3120	3129	
R	\$2851	2856	3120	3129	
68 L	\$2723	2727	2980	2989	
R	\$2723	2727	2980	2989	
70 L	\$2885	2889	3155	3163	
R	\$2885	2889	3155	3163	
		R	S	T	V
LQ310L 46 L	\$2873	2877	—	—	
R	\$2873	2877	—	—	
53 L	\$2772	2923	—	—	
R	\$2772	2923	—	—	
54 L	\$2795	2948	—	—	
R	\$2795	2948	—	—	
57 L	\$2973	2978	—	—	
R	\$2973	2978	—	—	
62 L	\$3144	3147	3439	3446	
R	\$3144	3147	3439	3446	
65 L	\$3179	3182	3477	3487	
R	\$3179	3182	3477	3487	
67 L	\$3214	3220	3517	3528	
R	\$3214	3220	3517	3528	
68 L	\$3070	3074	3359	3369	
R	\$3070	3074	3359	3369	
70 L	\$3252	3256	3556	3566	
R	\$3252	3256	3556	3566	

Step 7. Slides

For file/file (R) or file/file/file (T)

SB	full-extension ball-bearing	+\$0
-----------	-----------------------------	------

For box/box/file (S) or box/box/file/file (V)

SR	3/4-extension roller slides on box drawer, full-extension ball bearing on file drawer	+\$0
SB	full-extension ball-bearing	+\$50

Step 8. Paint/Steel Type

SS	smooth paint on smooth steel	+\$0
XS	textured paint on smooth steel	+\$0

Step 9. Surface Finish

For smooth paint on smooth steel (SS)

8Q	folkstone grey	+\$0
98	studio white	+\$0
BU	black umber	+\$0
CN	metallic champagne	+\$0
EH	metallic bronze	+\$0
HF	inner tone light	+\$0
LT	light tone	+\$0
LU	soft white	+\$0
MS	metallic silver	+\$0
MT	medium tone	+\$0
SG	slate grey	+\$0
WL	sandstone	+\$0

Sand Texture Paint

For textured paint on smooth steel (XS)

91	white	+\$0
98	studio white	+\$0
BK	black	+\$0
CL	cool grey neutral	+\$0
G1	graphite	+\$0
WN	warm grey neutral	+\$0

Step 10. Lock

KA	keyed alike	-\$10
KC	keyed differently, chrome	+\$0
KD	keyed differently, black	+\$0

Step 11. Pull Finish

NH	brushed nickel	+\$0
NK	black nickel	+\$0

Step 12. Wardrobe Interior

CH	coat hook	+\$0
CR	coat rod	+\$15

Step 13. Drawer Interior

For file/file (R) or file/file/file (T)

NN	none	+\$0
1M	2 file converters in each file drawer	+\$25
C51	storage organizer including hanging file holder bin, utility tray and two containers A	+\$120

Arc Pull Storage Tower *continued*

Tu® Metal Storage

For box/box/file (S) or box/box/file/file (V)

NN	none	+\$0
2M	drawer divider in box drawers, 2 file converters in file drawer	+\$25
3M	drawer divider in one box drawer, pencil tray in one box drawer, 2 file converters in file drawer	+\$25
C51	storage organizer including hanging file holder bin, utility tray and two containers A	+\$120

W-Pull Storage Tower

LW300.
LW310.

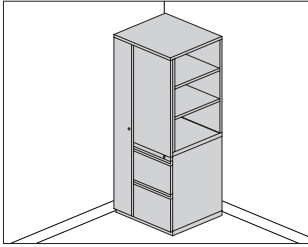

Product Information

Description

This freestanding storage tower has a wardrobe on 1 side and the option of a storage case or side-facing bookcase on the other side. Pedestal is located opposite of wardrobe. The tower has a smooth-steel case, full-width pulls, and recessed base with 1" leveling glides. Available in 9 heights.

Actual tower depth is 23¹/₄". Actual tower width is 23⁷/₈".

9"-wide wardrobe is available with a coat hook or coat rod.

15"-wide storage case is locking and has 1 or 2 adjustable shelves.

Shelves adjust in 1¹/₄" increments, starting 7" from the bottom of the storage case.

Side-facing bookcase is 14¹/₂" deep and 23¹/₄" wide. It includes 1 or 2 adjustable shelves that adjust in 1¹/₄" increments.

Pedestal is locking, with one lock securing all drawers. It includes a positive interlock system that permits only 1 drawer to open at a time. Drawers are available in a variety of box and file drawer configurations. Box drawers are available with full-extension or 3/4-extension slides and include a drawer divider, utility tray or storage organizer. File drawers have full-extension slides and hold letter-size front-to-back hanging files. File converters are optional for letter-, legal- and A4-size side-to-side hanging files.

Notes

The following chart shows the number of adjustable shelves in each storage case/side-facing bookcase based on tower height:

Height—Shelves

- 46" h (45" actual)—1 shelf
- 53" h (52¹/₂" actual)—1 shelf
- 54" h (53¹/₂" actual)—1 shelf
- 57" h (56" actual)—1 shelf
- 62" h (61¹/₂" actual)—1 shelf
- 65" h (64¹/₂" actual)—2 shelves
- 67" h (66¹/₂" actual)—2 shelves
- 68" h (67" actual)—2 shelves
- 70" h (69¹/₂" actual)—2 shelves

Dimensional illustrations do not include all possible configurations.

Order optional accessories separately:

- File compressor (LG908)
- File drawer organizer (LG901)
- Pedestal stationery divider (LG905)
- Storage organizer (LG910)

Storage organizer includes a hanging file holder, utility tray (pencil tray) and 2 containers. The storage organizer frame color matches the drawer interior; file holder and containers are g1 white; utility tray is black.

All locks in tower are factory installed and are keyed alike within the tower. For specific numbering choices, specify KA and order lock plugs separately. See Keyed-Alike Information in Appendices.

Dimensions

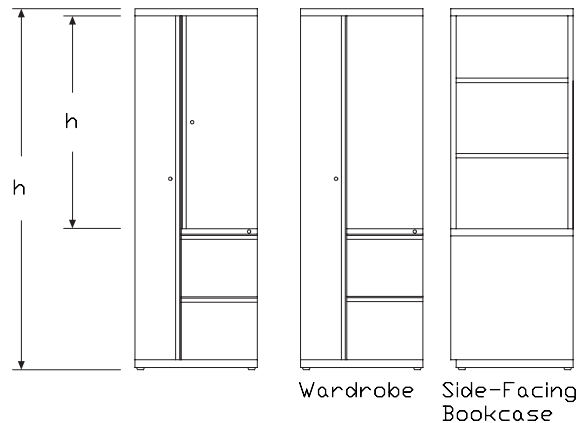
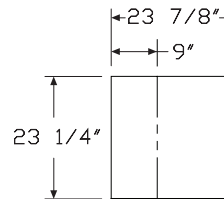

W-Pull Storage Tower *continued*

Tu® Metal Storage

Specification Information

Step 1.

LW3

Step 2. Storage Configuration

00. storage case

10. side-facing bookcase

Step 3. Height

46 46" high

53 53" high

54 54" high

57 57" high

62 62" high

65 65" high

67 67" high

68 68" high

70 70" high

Step 4. Wardrobe Location

L wardrobe left

R wardrobe right

Step 5. Drawer Configuration

For 46" high (46), 53" high (53), 54" high (54), or 57" high (57)

R file/file

S box/box/file

For 62" high (62), 65" high (65), 67" high (67), 68" high (68), or 70" high (70)

R file/file

S box/box/file

T file/file/file

V box/box/file/file

Prices for Steps 1-5.

	R	S	T	V
LW300.46 L	\$2149	2185	—	—
R	\$2149	2185	—	—
53 L	\$2183	2220	—	—
R	\$2183	2220	—	—
54 L	\$2204	2242	—	—
R	\$2204	2242	—	—
57 L	\$2226	2267	—	—
R	\$2226	2267	—	—

62 L	\$2307	2346	2521	2565
R	\$2307	2346	2521	2565
65 L	\$2337	2375	2554	2596
R	\$2337	2375	2554	2596
67 L	\$2362	2401	2583	2625
R	\$2362	2401	2583	2625
68 L	\$2305	2342	2519	2560
R	\$2305	2342	2519	2560
70 L	\$2390	2429	2612	2655
R	\$2390	2429	2612	2655

	R	S	T	V
LW310.46 L	\$2206	2241	—	—
R	\$2206	2241	—	—
53 L	\$2239	2277	—	—
R	\$2239	2277	—	—
54 L	\$2261	2300	—	—
R	\$2261	2300	—	—
57 L	\$2283	2321	—	—
R	\$2283	2321	—	—
62 L	\$2365	2404	2586	2627
R	\$2365	2404	2586	2627
65 L	\$2393	2432	2617	2657
R	\$2393	2432	2617	2657
67 L	\$2420	2457	2645	2687
R	\$2420	2457	2645	2687
68 L	\$2360	2397	2579	2618
R	\$2360	2397	2579	2618
70 L	\$2446	2486	2674	2718
R	\$2446	2486	2674	2718

Step 6. Slides

For file/file (R) or file/file/file (T)

SB full-extension ball-bearing +\$0

For box/box/file (S) or box/box/file/file (V)

SR 3/4-extension roller slides on box drawer, full-extension ball bearing on file drawer +\$0

SB full-extension ball-bearing +\$50

Step 7. Paint/Steel Type

SS smooth paint on smooth steel +\$0

XS textured paint on smooth steel +\$0

W-Pull Storage Tower *continued*

Step 8. Surface Finish

<i>For smooth paint on smooth steel (SS)</i>		
8Q	folkstone grey	+\$0
98	studio white	+\$0
BU	black umber	+\$0
CN	metallic champagne	+\$0
EH	metallic bronze	+\$0
HF	inner tone light	+\$0
LT	light tone	+\$0
LU	soft white	+\$0
MS	metallic silver	+\$0
MT	medium tone	+\$0
SG	slate grey	+\$0
WL	sandstone	+\$0

Sand Texture Paint

<i>For textured paint on smooth steel (XS)</i>		
91	white	+\$0
98	studio white	+\$0
BK	black	+\$0
CL	cool grey neutral	+\$0
G1	graphite	+\$0
WN	warm grey neutral	+\$0

Step 9. Lock

KA	keyed alike	-\$10
KC	keyed differently, chrome	+\$0
KD	keyed differently, black	+\$0

Step 10. Wardrobe Interior

CH	coat hook	+\$0
CR	coat rod	+\$15

Step 11. Drawer Interior

<i>For file/file (R) or file/file/file (T)</i>		
NN	none	+\$0
1M	2 file converters in each file drawer	+\$25
C51	storage organizer including hanging file holder bin, utility tray and two containers A	+\$120

<i>For box/box/file (S) or box/box/file/file (V)</i>		
NN	none	+\$0
2M	drawer divider in box drawers, 2 file converters in file drawer	+\$25
3M	drawer divider in one box drawer, pencil tray in one box drawer, 2 file converters in file drawer	+\$25
C51	storage organizer including hanging file holder bin, utility tray and two containers A	+\$120

V-Pull Storage Tower

LV300.
LV310.

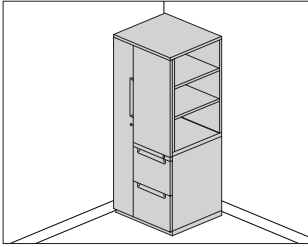

Tu® Metal Storage

Product Information

Description

This freestanding storage tower has a wardrobe on 1 side and the option of a storage case or side-facing bookcase on the other side. Pedestal is located opposite of wardrobe. The tower has a smooth-steel case, full-width recessed pulls, and recessed base with 1" leveling glides.

Available in 9 heights.

Actual tower depth is 23 1/4". Actual tower width is 23 7/8".

9"-wide wardrobe is available with a coat hook or coat rod.

15"-wide storage case is locking and has 1 or 2 adjustable shelves.

Shelves adjust in 1 1/4" increments, starting 7" from the bottom of the storage case.

Side-facing bookcase is 14 1/2" deep and 23 1/4" wide. It includes 1 or 2 adjustable shelves that adjust in 1 1/4" increments.

Pedestal is locking, with one lock securing all drawers. It includes a positive interlock system that permits only 1 drawer to open at a time. Drawers are available in a variety of box and file drawer configurations. Box drawers are available with full-extension or 3/4-extension slides and include a drawer divider, utility tray, or storage organizer. File drawers have full-extension slides and hold letter-size front-to-back hanging files. File converters are optional for letter-, legal- and A4-size side-to-side hanging files.

Notes

The following chart shows the number of adjustable shelves in each storage case/side-facing bookcase based on tower height:

Height—Shelves

- 46" h (45" actual)—1 shelf
- 53" h (52 1/2" actual)—1 shelf
- 54" h (53 1/2" actual)—1 shelf
- 57" h (56" actual)—1 shelf
- 62" h (61 1/2" actual)—1 shelf
- 65" h (64 1/2" actual)—2 shelves
- 67" h (66 1/2" actual)—2 shelves
- 68" h (67" actual)—2 shelves
- 70" h (69 1/2" actual)—2 shelves

Dimensional illustrations do not include all possible configurations.

Order optional accessories separately:

- File compressor (LG908)
- File drawer organizer (LG901)
- Pedestal stationery divider (LG905)
- Storage organizer (LG910)

Storage organizer includes a hanging file holder, utility tray (pencil tray) and 2 containers. The storage organizer frame color matches the drawer interior; file holder and containers are 91 white; utility tray is black.

All locks in tower are factory installed and are keyed alike within the tower. For specific numbering choices, specify KA and order lock plugs separately. See Keyed-Alike Information in Appendices.

Dimensions

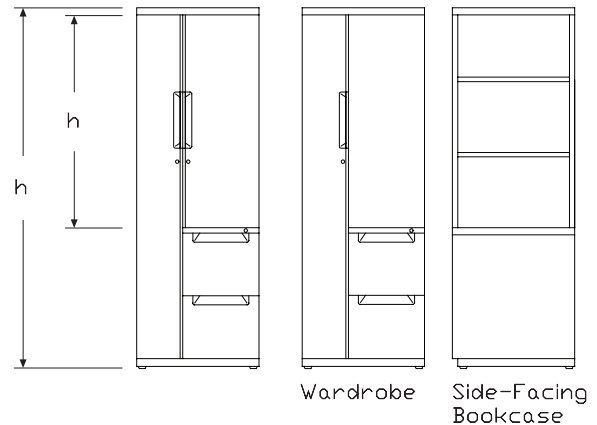
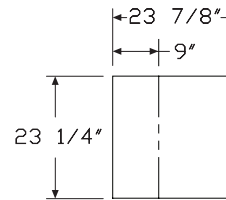

V-Pull Storage Tower *continued*

Specification Information

Step 1.

LV3

Step 2. Storage Configuration

- 00.** storage case
- 10.** side-facing bookcase

Step 3. Height

- 46** 46" high
- 53** 53" high
- 54** 54" high
- 57** 57" high
- 62** 62" high
- 65** 65" high
- 67** 67" high
- 68** 68" high
- 70** 70" high

Step 4. Wardrobe Location

- L** wardrobe left
- R** wardrobe right

Step 5. Drawer Configuration

For 46" high (46), 53" high (53), 54" high (54), or 57" high (57)

- R** file/file
- S** box/box/file

For 62" high (62), 65" high (65), 67" high (67), 68" high (68), or 70" high (70)

- R** file/file
- S** box/box/file
- T** file/file/file
- V** box/box/file/file

Prices for Steps 1-5.

	R	S	T	V
LV300. 46 L	\$2459	2499	—	—
R	\$2459	2499	—	—
53 L	\$2496	2542	—	—
R	\$2496	2542	—	—
54 L	\$2521	2566	—	—
R	\$2521	2566	—	—
57 L	\$2548	2594	—	—
R	\$2548	2594	—	—

62 L	\$2638	2683	2885	2935
R	\$2638	2683	2885	2935
65 L	\$2672	2716	2921	2970
R	\$2672	2716	2921	2970
67 L	\$2705	2748	2956	2832
R	\$2705	2748	2956	2832
68 L	\$2635	2678	2880	2930
R	\$2635	2678	2880	2930
70 L	\$2736	2781	2990	3041
R	\$2736	2781	2990	3041

	R	S	T	V
LV310. 46 L	\$2575	2617	—	—
R	\$2575	2617	—	—
53 L	\$2613	2657	—	—
R	\$2613	2657	—	—
54 L	\$2637	2682	—	—
R	\$2637	2682	—	—
57 L	\$2664	2709	—	—
R	\$2664	2709	—	—
62 L	\$2759	2804	3015	3065
R	\$2759	2804	3015	3065
65 L	\$2792	2837	3051	3101
R	\$2792	2837	3051	3101
67 L	\$2824	2868	3087	3135
R	\$2824	2868	3087	3135
68 L	\$2752	2795	3009	3055
R	\$2752	2795	3009	3055
70 L	\$2855	2901	3121	3172
R	\$2855	2901	3121	3172

Step 6. Slides

For file/file (R) or file/file/file (T)

- SB** full-extension ball-bearing +\$0

For box/box/file (S) or box/box/file/file (V)

- SR** ¾-extension roller slides on box drawer, full-extension ball bearing on file drawer +\$0
- SB** full-extension ball-bearing +\$50

Step 7. Paint/Steel Type

- SS** smooth paint on smooth steel +\$0
- XS** textured paint on smooth steel +\$0

V-Pull Storage Tower *continued*

Tu® Metal Storage

Step 8. Surface Finish

For smooth paint on smooth steel (SS)

8Q	folkstone grey	+\$0
98	studio white	+\$0
BU	black umber	+\$0
CN	metallic champagne	+\$0
EH	metallic bronze	+\$0
HF	inner tone light	+\$0
LT	light tone	+\$0
LU	soft white	+\$0
MS	metallic silver	+\$0
MT	medium tone	+\$0
SG	slate grey	+\$0
WL	sandstone	+\$0

Sand Texture Paint

For textured paint on smooth steel (XS)

91	white	+\$0
98	studio white	+\$0
BK	black	+\$0
CL	cool grey neutral	+\$0
G1	graphite	+\$0
WN	warm grey neutral	+\$0

Step 9. Lock

KA	keyed alike	-\$10
KC	keyed differently, chrome	+\$0
KD	keyed differently, black	+\$0

Step 10. Wardrobe Interior

CH	coat hook	+\$0
CR	coat rod	+\$15

Step 11. Drawer Interior

For file/file (R) or file/file/file (T)

NN	none	+\$0
1M	2 file converters in each file drawer	+\$25
C51	storage organizer including hanging file holder bin, utility tray and two containers A	+\$120

For box/box/file (S) or box/box/file/file (V)

NN	none	+\$0
2M	drawer divider in box drawers, 2 file converters in file drawer	+\$25
3M	drawer divider in one box drawer, pencil tray in one box drawer, 2 file converters in file drawer	+\$25
C51	storage organizer including hanging file holder bin, utility tray and two containers A	+\$120

W-Pull Storage Tower, No Wardrobe

LW320.
LW330.

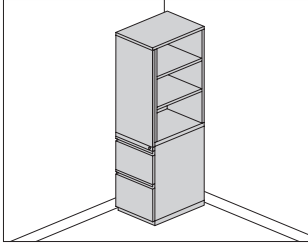

Product Information

Description

This freestanding storage tower has a pedestal in the lower section and the option of a storage case or side-facing bookcase above. It has a smooth-steel case, full-width pulls, and recessed base with 1" leveling glides.

Storage case is locking and has 1 or 2 adjustable shelves. Shelves adjust in 1 1/4" increments.

Side-facing bookcase is 14 1/2" deep and 23 3/4" wide. It includes 1 or 2 adjustable shelves (except 42" high) that adjust in 1 1/4" increments.

Pedestal is locking, with one lock securing all drawers. It includes a positive interlock system that permits only 1 drawer to open at a time. Drawers are available in box/box/file or file/file configuration. Box drawers are available with full-extension or 3/4-extension slides and include a drawer divider, utility tray or storage organizer. File drawers have full-extension slides and hold letter-size front-to-back hanging files. File converters are optional for letter-, legal- and A4-size side-to-side hanging files.

Notes

The following chart shows the number of adjustable shelves in each storage case/side-facing bookcase based on tower height:

Height—Shelves

42" h (41" actual)—0 shelves

46" h (45" actual)—1 shelf

57" h (56" actual)—1 shelf

68" h (67" actual)—2 shelves

Order optional accessories separately:

- File compressor (LG908)
- File drawer organizer (LG901)
- Pedestal stationery divider (LG905)
- Storage organizer (LG910)

Storage organizer includes a hanging file holder, utility tray (pencil tray) and 2 containers. The storage organizer frame color matches the drawer interior; file holder and containers are 91 white; utility tray is black.

All locks in tower are factory installed and are keyed alike within the tower. For specific numbering choices, specify KA and order lock plugs separately. See Keyed-Alike Information in Appendices.

Dimensions

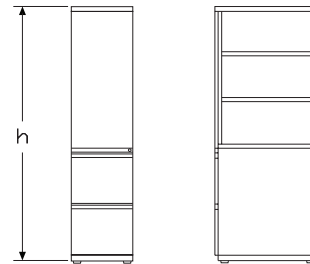
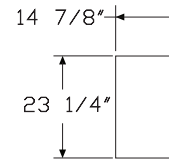

W-Pull Storage Tower, No Wardrobe *continued*

Tu® Metal Storage

Specification Information

Step 1.

LW3

Step 2. Storage Configuration

- 20.** storage case
- 30.** side-facing bookcase

Step 3. Height

For storage case (20.)

- 46** 46" high
- 57** 57" high
- 68** 68" high

For side-facing bookcase (30.)

- 42** 42" high
- 46** 46" high
- 57** 57" high
- 68** 68" high

Step 4. Door or Bookcase Direction

- L** left-hinged door or left-facing bookcase
- R** right-hinged door or right-facing bookcase

Step 5. Drawer Configuration

- R** file/file
- S** box/box/file

Prices for Steps 1-5.

	R	S
LW320.46 L	\$1575	1603
R	\$1575	1603
57 L	\$1634	1661
R	\$1634	1661
68 L	\$1690	1719
R	\$1690	1719
	R	S
LW330.42 L	\$1521	1545
R	\$1521	1545
46 L	\$1575	1602
R	\$1575	1602
57 L	\$1633	1661
R	\$1633	1661
68 L	\$1690	1720
R	\$1690	1720

Step 6. Slides

For file/file (R)

- SB** full-extension ball-bearing +\$0

For box/box/file (S)

- SR** 3/4-extension roller slides on box drawer, full-extension ball bearing on file drawer +\$0
- SB** full-extension ball-bearing +\$50

Step 7. Paint/Steel Type

- SS** smooth paint on smooth steel +\$0
- XS** textured paint on smooth steel +\$0

Step 8. Surface Finish

For smooth paint on smooth steel (SS)

- 8Q** folkstone grey +\$0
- 98** studio white +\$0
- BU** black umber +\$0
- CN** metallic champagne +\$0
- EH** metallic bronze +\$0
- HF** inner tone light +\$0
- LT** light tone +\$0
- LU** soft white +\$0
- MS** metallic silver +\$0
- MT** medium tone +\$0
- SG** slate grey +\$0
- WL** sandstone +\$0

Sand Texture Paint

For textured paint on smooth steel (XS)

- 91** white +\$0
- 98** studio white +\$0
- BK** black +\$0
- CL** cool grey neutral +\$0
- G1** graphite +\$0
- WN** warm grey neutral +\$0

Step 9. Lock

- KA** keyed alike -\$10
- KC** keyed differently, chrome +\$0
- KD** keyed differently, black +\$0

W-Pull Storage Tower, No Wardrobe *continued*

Step 10. Drawer Interior

For file/file (R)

NN	none	+\$0
1M	2 file converters in each file drawer	+\$25
C51	storage organizer including hanging file holder bin, utility tray and two containers <input type="checkbox"/> A	+\$120

For box/box/file (S)

NN	none	+\$0
2M	drawer divider in box drawers, 2 file converters in file drawer	+\$25
3M	drawer divider in one box drawer, pencil tray in one box drawer, 2 file converters in file drawer	+\$25
C51	storage organizer including hanging file holder bin, utility tray and two containers <input type="checkbox"/> A	+\$120

V-Pull Storage Tower, No Wardrobe

LV320.
LV330.

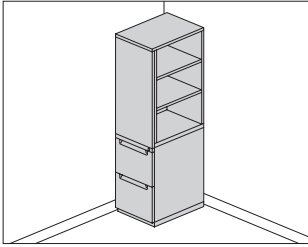

Tu® Metal Storage

Product Information

Description

This freestanding storage tower has a pedestal in the lower section and the option of a storage case or side-facing bookcase above. It has a smooth-steel case, full-width recessed pulls, and recessed base with 1" leveling glides.

Storage case is locking and has 1 or 2 adjustable shelves. Shelves adjust in 1 1/4" increments.

Side-facing bookcase is 14 1/2" deep and 23 1/4" wide. It includes 1 or 2 adjustable shelves (except 42" high) that adjust in 1 1/4" increments.

Pedestal is locking, with one lock securing all drawers. It includes a positive interlock system that permits only 1 drawer to open at a time. Drawers are available in box/box/file or file/file configuration. Box drawers are available with full-extension or 3/4-extension slides. File drawers have full-extension slides and hold letter-size front-to-back hanging files. File converters are optional for letter-, legal- and A4-size side-to-side hanging files.

Notes

42"-high tower is available with side-facing bookcase only.

The following chart shows the number of adjustable shelves in each storage case/side-facing bookcase based on tower height:

Height — Shelves

42" h (41" actual) — 0 shelves

46" h (45" actual) — 1 shelf

57" h (56" actual) — 1 shelf

68" h (67" actual) — 2 shelves

Order optional accessories separately:

- File compressor (LG908)
- File drawer organizer (LG901)
- Pedestal stationery divider (LG905)
- Storage organizer (LG910)

Storage organizer includes a hanging file holder, utility tray (pencil tray) and 2 containers. The storage organizer frame color matches the drawer interior; file holder and containers are 91 white; utility tray is black.

All locks in tower are factory installed and are keyed alike within the tower. For specific numbering choices, specify KA and order lock plugs separately. See Keyed-Alike Information in Appendices.

Dimensions

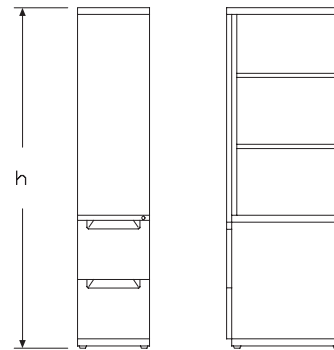
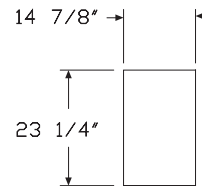

V-Pull Storage Tower, No Wardrobe *continued*

Specification Information

Step 1.

LV3

Step 2. Storage Configuration

20. storage case

30. side-facing bookcase

Step 3. Height

For storage case (20.)

46 46" high

57 57" high

68 68" high

For side-facing bookcase (30.)

42 42" high

46 46" high

57 57" high

68 68" high

Step 4. Door or Bookcase Direction

L left-hinged door or left-facing bookcase

R right-hinged door or right-facing bookcase

Step 5. Drawer Configuration

R file/file

S box/box/file

Prices for Steps 1-5.

	R	S
LV320. 46 L	\$1731	1761
R	\$1731	1761
57 L	\$1793	1825
R	\$1793	1825
68 L	\$1855	1889
R	\$1855	1889
	R	S
LV330. 42 L	\$1719	1747
R	\$1719	1747
46 L	\$1780	1812
R	\$1780	1812
57 L	\$1844	1875
R	\$1844	1875
68 L	\$1910	1944
R	\$1910	1944

Step 6. Slides

For file/file (R)

SB full-extension ball-bearing +\$0

For box/box/file (S)

SR ¾-extension roller slides on box drawer, full-extension ball bearing on file drawer +\$0

SB full-extension ball-bearing +\$50

Step 7. Paint/Steel Type

SS smooth paint on smooth steel +\$0

XS textured paint on smooth steel +\$0

Step 8. Surface Finish

For smooth paint on smooth steel (SS)

8Q folkstone grey +\$0

98 studio white +\$0

BU black umber +\$0

CN metallic champagne +\$0

EH metallic bronze +\$0

HF inner tone light +\$0

LT light tone +\$0

LU soft white +\$0

MS metallic silver +\$0

MT medium tone +\$0

SG slate grey +\$0

WL sandstone +\$0

Sand Texture Paint

For textured paint on smooth steel (XS)

91 white +\$0

98 studio white +\$0

BK black +\$0

CL cool grey neutral +\$0

G1 graphite +\$0

WN warm grey neutral +\$0

Step 9. Lock

KA keyed alike -\$10

KC keyed differently, chrome +\$0

KD keyed differently, black +\$0

V-Pull Storage Tower, No Wardrobe *continued*

Tu® Metal Storage

Step 10. Drawer Interior

For file/file (R)

NN	none	+\$0
1M	2 file converters in each file drawer	+\$25
C51	storage organizer including hanging file holder bin, utility tray and two containers A	+\$120

For box/box/file (S)

NN	none	+\$0
2M	drawer divider in box drawers, 2 file converters in file drawer	+\$25
3M	drawer divider in one box drawer, pencil tray in one box drawer, 2 file converters in file drawer	+\$25
C51	storage organizer including hanging file holder bin, utility tray and two containers A	+\$120

W-Pull Wardrobe Cabinet

LW380.

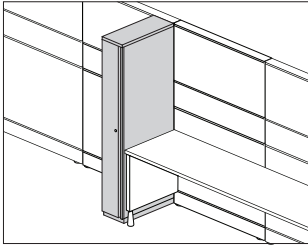

Product Information

Description

This single wardrobe attaches to a Canvas frame, another tower or cabinet, or an architectural wall. It has a smooth-steel case, an integrated pull, and recessed base with 1" leveling glides. The interior is available with a coat rod or coat hook.

Actual cabinet height is 41", 45", 56", or 67".

Notes

Wardrobe cannot be used freestanding. It must be anchored to another tower or cabinet, or be attached to a frame or architectural wall.

For keyed-alike locks, order lock plugs separately. See Keyed-Alike Information in Appendices.

Dimensions

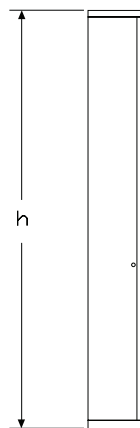
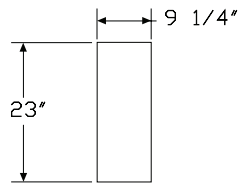

Specification Information

Step 1.

LW380.

Step 2. Height

42	42" high
46	46" high
57	57" high
68	68" high

Step 3. Configuration

L	left-hinged door
R	right-hinged door

Prices for Steps 1-3.

	L	R
LW380. 42	\$1142	1142
46	\$1184	1184
57	\$1226	1226
68	\$1270	1270

Step 4. Attachment

F8	Canvas frame attachment	+\$0
F5	tower/cabinet attachment	+\$0

Step 5. Paint/Steel Type

SS	smooth paint on smooth steel	+\$0
XS	textured paint on smooth steel	+\$0

Step 6. Surface Finish

For smooth paint on smooth steel (SS)

8Q	folkstone grey	+\$0
98	studio white	+\$0
BU	black umber	+\$0
CN	metallic champagne	+\$0
EH	metallic bronze	+\$0
HF	inner tone light	+\$0
LT	light tone	+\$0
LU	soft white	+\$0
MS	metallic silver	+\$0
MT	medium tone	+\$0
SG	slate grey	+\$0
WL	sandstone	+\$0

W-Pull Wardrobe Cabinet *continued*

Tu® Metal Storage

Sand Texture Paint

For textured paint on smooth steel (XS)

91	white	+\$0
98	studio white	+\$0
BK	black	+\$0
CL	cool grey neutral	+\$0
G1	graphite	+\$0
WN	warm grey neutral	+\$0

Step 7. Interior

CR	coat rod	+\$15
CH	coat hook	+\$15

Step 8. Lock

KA	keyed alike	-\$10
KC	keyed differently, chrome	+\$0
KD	keyed differently, black	+\$0

V-Pull Wardrobe Cabinet

LV380.

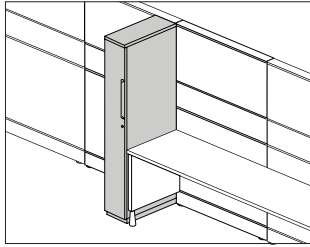

Product Information

Description

This single wardrobe attaches to a Canvas frame, another tower or cabinet, or an architectural wall. It has a smooth-steel case, a recessed pull, and recessed base with 1" leveling glides. The interior is available with a coat rod or coat hook.

Actual cabinet height is 41", 45", 56", or 67".

Notes

Wardrobe cannot be used freestanding. It must be anchored to another tower or cabinet, or be attached to a frame or architectural wall.

For keyed-alike locks, order lock plugs separately. See Keyed-Alike Information in Appendices.

Dimensions

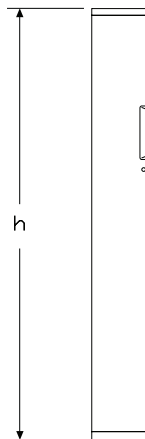
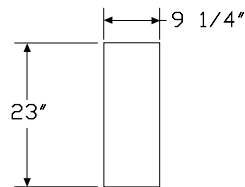

Specification Information

Step 1.

LV380.

Step 2. Height

42	42" high
46	46" high
57	57" high
68	68" high

Step 3. Configuration

L	left-hinged door
R	right-hinged door

Prices for Steps 1-3.

	L	R
LV380. 42	\$1135	1135
46	\$1175	1175
57	\$1216	1216
68	\$1258	1258

Step 4. Attachment

F8	Canvas frame attachment	+\$0
F5	tower/cabinet attachment	+\$0

Step 5. Paint/Steel Type

SS	smooth paint on smooth steel	+\$0
XS	textured paint on smooth steel	+\$0

Step 6. Surface Finish

For smooth paint on smooth steel (SS)

8Q	folkstone grey	+\$0
98	studio white	+\$0
BU	black umber	+\$0
CN	metallic champagne	+\$0
EH	metallic bronze	+\$0
HF	inner tone light	+\$0
LT	light tone	+\$0
LU	soft white	+\$0
MS	metallic silver	+\$0
MT	medium tone	+\$0
SG	slate grey	+\$0
WL	sandstone	+\$0

V-Pull Wardrobe Cabinet *continued*

Tu® Metal Storage

Sand Texture Paint

For textured paint on smooth steel (XS)

91	white	+\$0
98	studio white	+\$0
BK	black	+\$0
CL	cool grey neutral	+\$0
G1	graphite	+\$0
WN	warm grey neutral	+\$0

Step 7. Interior

CR	coat rod	+\$15
CH	coat hook	+\$15

Step 8. Lock

KA	keyed alike	-\$10
KC	keyed differently, chrome	+\$0
KD	keyed differently, black	+\$0

Tu® Storage Tower Attachment Bracket

LG692

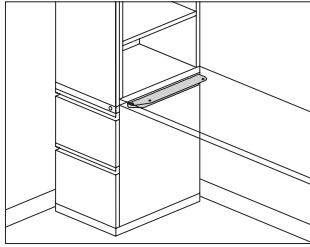

Product Information

Description

This bracket attaches to the side of a Tu Metal storage tower to support 1 end of a 24" deep surface, eliminating the need for a support leg or cantilever. Finish is black. Attachment hardware included.

Notes

Bracket must attach to the pedestal side of a metal storage tower.
Bracket does not provide support for a panel or frame.

Dimensions

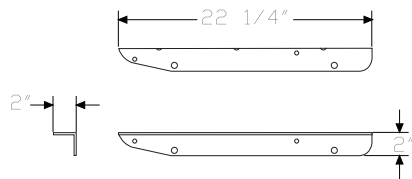

Specification Information

Step 1.

LG692

\$45

File Drawer Organizer

LG901

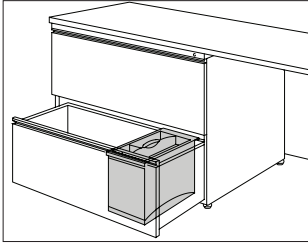

Tu® Metal Storage

Product Information

Description

This 2-sectioned organizer fits into any file drawer arranged for letter-size filing. The removable top section stores computer disks and other small items. The bottom section stores larger items or can be divided into 3 compartments; it includes 2 vertical dividers. Finish is black umber.

Dimensions

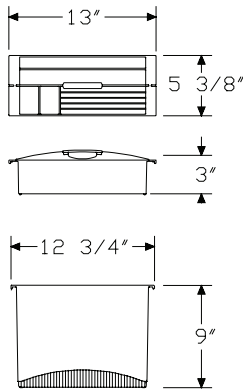

Specification Information

Step 1.

LG901

\$84

Drawer Divider, Tu® Pedestal

LG903.

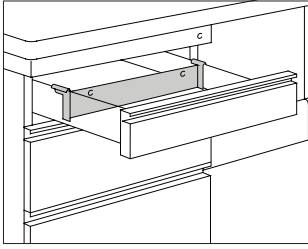

Product Information

Description

This adjustable divider is used in a pencil or box drawer. Finish is black umber.

Notes

Divider can be used in the following products:

- 5000 Series furniture with B- and F-pull pedestals
- Tu® Q-, R-, T-, V-, and W-pull pedestals
- Tu storage towers

Dimensions

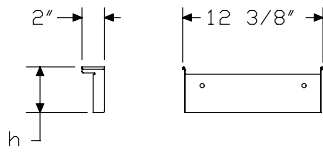

Specification Information

Step 1.

LG903.

Step 2. Usage

- 3** for pencil drawer
- 6** for box drawer

Prices for Steps 1-2.

LG903. 3	\$16
6	\$17

Stationery Divider, Tu® Pedestal LG905

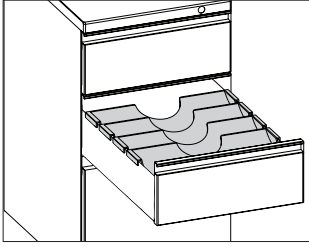

Tu® Metal Storage

Product Information

Description

These 4 removable dividers are used in box drawers. Finish is black
umber.

Notes

Dividers can be used in the following products:

- 5000 Series furniture with B- and F-pull pedestals
- Tu® Q-, R-, T-, V-, and W-pull pedestals
- Tu storage towers

Dimensions

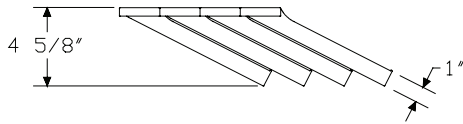

Specification Information

Step 1.

LG905

\$56

Utility Tray, Tu® Pedestal

LG906

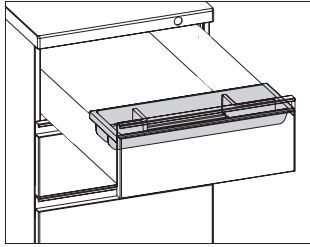

Product Information

Description

This sectioned tray stores pencils and small items in a pencil or box drawer. Finish is black umber.

Notes

Tray can be used in the following products:

- 5000 Series furniture with B- and F-pull pedestals
- Tu® Q-, R-, T-, V-, and W-pull pedestals
- Tu storage towers

Dimensions

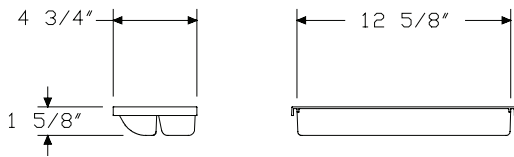

Specification Information

Step 1.

LG906

\$20

Tu® Metal Storage

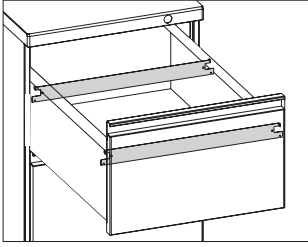

Tu® Metal Storage

Product Information

Description

These black umber bars convert a file drawer to hold letter-, legal-, and A4-size side-to-side hanging files. 2 converters are used per drawer. Package contains 4.

Notes

- Converters can be used in the following products:
- 5000 Series furniture with B- and F-pull pedestals
 - Tu® Q-, R-, T-, V-, and W-pull pedestals
 - Tu storage towers

Dimensions

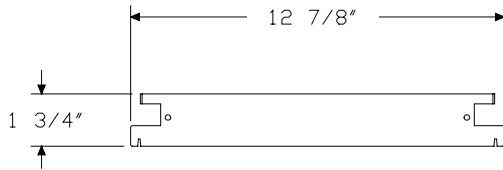

Specification Information

Step 1.

LG907

\$28

File Compressor, Tu®

LG908

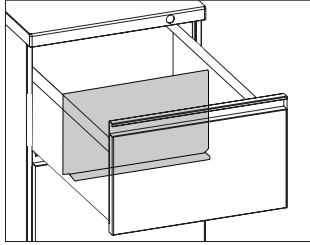

Product Information

Description

These compressors lock into slots in the bottom of a pedestal file drawer to divide non-hanging files. Finish is black umber. Package contains 4.

Notes

Compressors can be used in the following products:

- 5000 Series furniture with B- and F-pull pedestals
- Tu® Q-, R-, T-, V-, and W-pull pedestals
- Tu storage towers

Dimensions

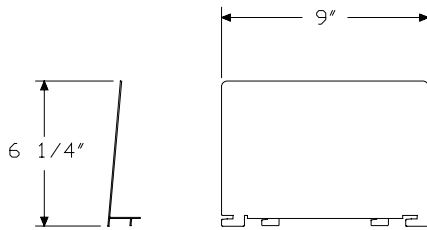

Specification Information

Step 1.

LG908

\$46

Bar-Pull Storage Case

LK400D
LK400L

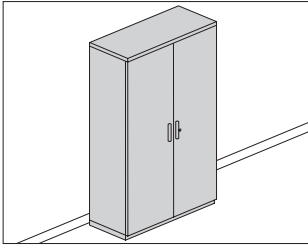

Tu® Metal Storage

Product Information

Description

This freestanding storage case is smooth-steel with hinged doors that open to 110° and has applied metal bar pulls. It includes 1 or more shelves, depending on height. Shelves adjust in 1¼" increments. All bases have ¾" leveling glides. Available in 3 widths and 4 heights. Actual case depth is 19¾". Actual width is 29½", 35½", or 41½".

Notes

The following chart shows the number of adjustable shelves in each storage case and vertical clearance between shelves when evenly spaced:

Height—Shelves—Bottom space—Mid-space—Top space

26" h (27¼" actual)—1 shelf—11⅞"—n/a—10½"

38" h (39⅞" actual)—2 shelves—11⅞"—12⅝"—8⅞"

51" h (51½" actual)—3 shelves—11⅞"—(2) 12⅝"—7½"

64" h (64⅞" actual)—4 shelves—11⅞"—(3) 12⅝"—7⅞"

Coat rod (option CR) may be specified in place of shelves.

Coat rod option does not allow shelves to be added later.

Dimensional illustrations do not include all possible configurations.

Order additional storage shelf (LG940.) separately.

For keyed-alike locks, order lock plugs separately. See Keyed-Alike Information in Appendices.

Dimensions

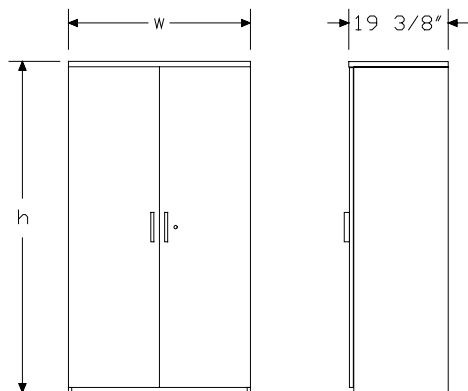

Specification Information

Step 1.

LK400

Step 2. Front Material

- D. painted metal front
- L. laminate front

Step 3. Width

- 30 30" wide
- 36 36" wide
- 42 42" wide

Step 4. Height

- 26 26" high
- 38 38" high
- 51 51" high
- 64 64" high

Prices for Steps 1-4.

	26	38	51	64
LK400D. 30	\$1023	1222	1566	1742
36	\$1159	1380	1691	1880
42	\$1308	1559	1827	2032
LK400L. 30	\$1153	1376	1765	1963
36	\$1305	1555	1906	2119
42	\$1475	1758	2060	2291

Step 5. Paint/Steel Type

- SS** smooth paint on smooth steel +\$0
- XS** textured paint on smooth steel +\$0

Step 6. Surface Finish

For smooth paint on smooth steel (SS)

- 8Q** folkstone grey +\$0
- 98** studio white +\$0
- BU** black umber +\$0
- HF** inner tone light +\$0
- LT** light tone +\$0
- LU** soft white +\$0
- MT** medium tone +\$0
- SG** slate grey +\$0
- WL** sandstone +\$0

Bar-Pull Storage Case *continued*

For smooth paint on smooth steel (SS)

CN	metallic champagne	+\$0
EH	metallic bronze	+\$0
MS	metallic silver	+\$0

Sand Texture Paint

For textured paint on smooth steel (XS)

91	white	+\$0
98	studio white	+\$0
BK	black	+\$0
CL	cool grey neutral	+\$0
G1	graphite	+\$0
WN	warm grey neutral	+\$0

Step 7. Interior

For 64" high (64)

CR	coat rod	-\$148
NS4	4 shelves total	+\$0

Step 8. Lock

KA	keyed alike	-\$10
KC	keyed differently, chrome	+\$0
KD	keyed differently, black	+\$0

Step 9. Pull Finish

Metallic Paint

CN	metallic champagne	+\$0
MS	metallic silver	+\$0

Sand Texture Paint

79	green apple	+\$15
BK	black	+\$0
MY3	yellow oxide	+\$15
RO	red	+\$15
TRQ	turquoise	+\$15

Smooth Paint

8Q	folkstone grey	+\$0
91	white	+\$0
98	studio white	+\$0
G1	graphite	+\$0
WL	sandstone	+\$0

Arc Pull Storage Case

LQ400D
LQ400L

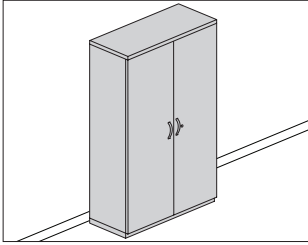

Tu® Metal Storage

Product Information

Description

This freestanding storage case is smooth-steel with hinged doors that open to 110° and has applied metal arc pulls. It includes 1 or more shelves, depending on height. Shelves adjust in 1/4" increments. All bases have 3/4" leveling glides. Available in 3 widths and 4 heights. Actual case depth is 19 3/8". Actual width is 29 1/2", 35 1/2", or 41 1/2".

Notes

Pull design conforms to guidelines of Americans with Disabilities Act (ADA).

The following chart shows the number of adjustable shelves in each storage case and vertical clearance between shelves when evenly spaced:

Height — Shelves — Bottom space — Mid-space — Top space

26" h (27 1/4" actual) — 1 shelf — 11 7/8" — n/a — 10 1/2"

38" h (39 1/8" actual) — 2 shelves — 11 7/8" — 12 5/8" — 8 7/8"

51" h (51 1/2" actual) — 3 shelves — 11 7/8" — (2) 12 5/8" — 7 1/2"

64" h (64 7/8" actual) — 4 shelves — 11 7/8" — (3) 12 5/8" — 7 3/8"

Coat rod (option CR) may be specified in place of shelves.

Coat rod option does not allow shelves to be added later.

Dimensional illustrations do not include all possible configurations.

Order additional storage shelf (LG940.) separately.

For keyed-alike locks, order lock plugs separately. See Keyed-Alike Information in Appendices.

Dimensions

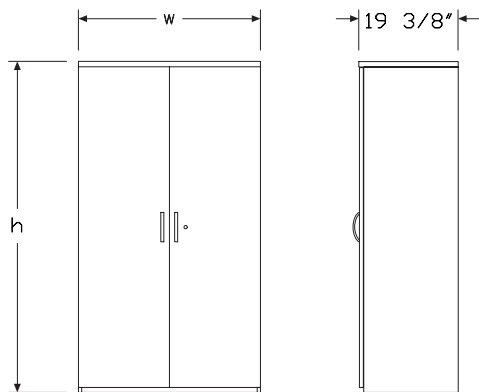

Specification Information

Step 1.

LQ400

Step 2. Front Material

- D. painted metal front
- L. laminate front

Step 3. Width

- 30 30" wide
- 36 36" wide
- 42 42" wide

Step 4. Height

- 26 26" high
- 38 38" high
- 51 51" high
- 64 64" high

Prices for Steps 1-4.

	26	38	51	64
LQ400D. 30	\$1023	1222	1566	1742
36	\$1159	1380	1691	1880
42	\$1308	1559	1827	2032
LQ400L. 30	\$1153	1376	1765	1963
36	\$1305	1555	1906	2119
42	\$1475	1758	2060	2291

Step 5. Paint/Steel Type

- SS smooth paint on smooth steel +\$0
- XS textured paint on smooth steel +\$0

Arc Pull Storage Case *continued*

Step 6. Surface Finish

For smooth paint on smooth steel (SS)

8Q	folkstone grey	+\$0
98	studio white	+\$0
BU	black umber	+\$0
CN	metallic champagne	+\$0
EH	metallic bronze	+\$0
HF	inner tone light	+\$0
LT	light tone	+\$0
LU	soft white	+\$0
MS	metallic silver	+\$0
MT	medium tone	+\$0
SG	slate grey	+\$0
WL	sandstone	+\$0

Sand Texture Paint

For textured paint on smooth steel (XS)

91	white	+\$0
98	studio white	+\$0
BK	black	+\$0
CL	cool grey neutral	+\$0
G1	graphite	+\$0
WN	warm grey neutral	+\$0

Step 7. Interior

For 64" high (64)

CR	coat rod	-\$148
NS4	4 shelves total	+\$0

Step 8. Lock

KA	keyed alike	-\$10
KC	keyed differently, chrome	+\$0
KD	keyed differently, black	+\$0

Step 9. Pull Finish

NH	brushed nickel	+\$0
NK	black nickel	+\$0

W-Pull Storage Case

LW400.

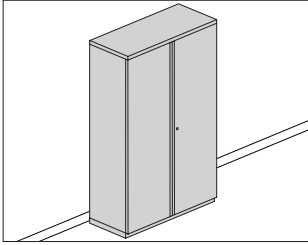

Tu® Metal Storage

Product Information

Description

This freestanding storage case is smooth-steel with hinged doors that open to 110° and has integrated pulls. It includes 1 or more shelves, depending on height. Shelves adjust in 1/4" increments. All bases have 3/4" leveling glides. Available in 3 widths and 4 heights. Actual case depth is 19 3/8". Actual width is 29 1/2", 35 1/2", or 41 1/2".

Notes

The following chart shows the number of adjustable shelves in each storage case and vertical clearance between shelves when evenly spaced:

Height—Shelves—Bottom space—Mid-space—Top space

26" h (27 1/4" actual)—1 shelf—11 7/8"—n/a—10 1/2"

38" h (39 1/8" actual)—2 shelves—11 7/8"—12 5/8"—8 7/8"

51" h (51 1/2" actual)—3 shelves—11 7/8"—(2) 12 5/8"—7 1/2"

64" h (64 7/8" actual)—4 shelves—11 7/8"—(3) 12 5/8"—7 3/8"

Coat rod (option CR) may be specified in place of shelves.

Coat rod option does not allow shelves to be added later.

Dimensional illustrations do not include all possible configurations.

Order additional storage shelf (LG940.) separately.

For keyed-alike locks, order lock plugs separately. See Keyed-Alike Information in Appendices.

Dimensions

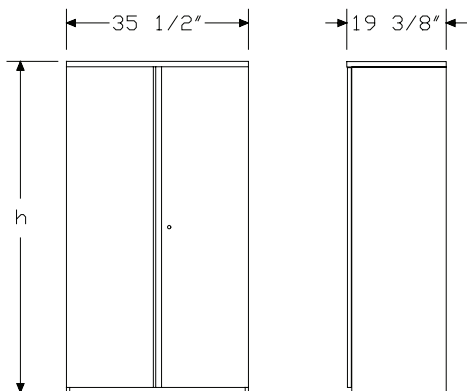

Specification Information

Step 1.

LW400.

Step 2. Width

30	30" wide
36	36" wide
42	42" wide

Step 3. Height

26	26" high
38	38" high
51	51" high
64	64" high

Prices for Steps 1-3.

	26	38	51	64
LW400.30	\$1020	1237	1436	1795
36	\$1124	1338	1642	1824
42	\$1267	1513	1772	1971

Step 4. Paint/Steel Type

SS	smooth paint on smooth steel			+\$0
XS	textured paint on smooth steel			+\$0

Step 5. Surface Finish

For smooth paint on smooth steel (SS)

8Q	folkstone grey	+\$0
98	studio white	+\$0
BU	black umber	+\$0
CN	metallic champagne	+\$0
EH	metallic bronze	+\$0
HF	inner tone light	+\$0
LT	light tone	+\$0
LU	soft white	+\$0
MS	metallic silver	+\$0
MT	medium tone	+\$0
SG	slate grey	+\$0
WL	sandstone	+\$0

W-Pull Storage Case *continued*

Sand Texture Paint

For textured paint on smooth steel (XS)

91	white	+\$0
98	studio white	+\$0
BK	black	+\$0
CL	cool grey neutral	+\$0
G1	graphite	+\$0
WN	warm grey neutral	+\$0

Step 6. Interior

For 64" high (64)

CR	coat rod	-\$148
NS4	4 shelves total	+\$0

Step 7. Lock

KA	keyed alike	-\$10
KC	keyed differently, chrome	+\$0
KD	keyed differently, black	+\$0

V-Pull Storage Case

LV400.

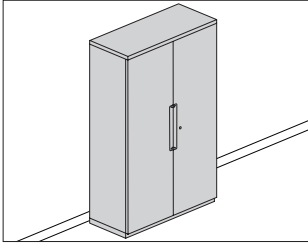

Tu® Metal Storage

Product Information

Description

This freestanding storage case is smooth-steel with hinged doors that open to 110° and has recessed pulls. It includes 1 or more shelves, depending on height. Shelves adjust in 1/4" increments. All bases have 3/4" leveling glides. Available in 3 widths and 4 heights. Actual case depth is 19 3/8". Actual width is 29 1/2", 35 1/2", or 41 1/2".

Notes

The following chart shows the number of adjustable shelves in each storage case and vertical clearance between shelves when evenly spaced:

Height—Shelves—Bottom space—Mid-space—Top space
 26" h (27 1/4" actual)—1 shelf—11 7/8"—n/a—10 1/2"
 38" h (39 1/8" actual)—2 shelves—11 7/8"—12 5/8"—8 7/8"
 51" h (51 1/2" actual)—3 shelves—11 7/8"—(2) 12 5/8"—7 1/2"
 64" h (64 7/8" actual)—4 shelves—11 7/8"—(3) 12 5/8"—7 3/8"

Coat rod (option CR) may be specified in place of shelves.

Coat rod option does not allow shelves to be added later.

Dimensional illustrations do not include all possible configurations.

Order additional storage shelf (LG940.) separately.

For keyed-alike locks, order lock plugs separately. See Keyed-Alike Information in Appendices.

Dimensions

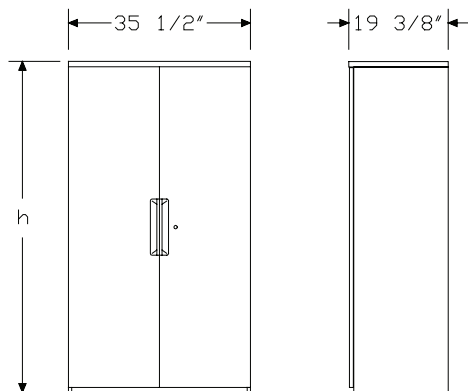

Specification Information

Step 1.

LV400.

Step 2. Width

30	30" wide
36	36" wide
42	42" wide

Step 3. Height

26	26" high
38	38" high
51	51" high
64	64" high

Prices for Steps 1-3.

	26	38	51	64
LV400. 30	\$1020	1239	1437	1796
36	\$1122	1339	1643	1826
42	\$1269	1513	1774	1971

Step 4. Paint/Steel Type

SS	smooth paint on smooth steel	+\$0
XS	textured paint on smooth steel	+\$0

Step 5. Surface Finish

For smooth paint on smooth steel (SS)

8Q	folkstone grey	+\$0
98	studio white	+\$0
BU	black umber	+\$0
CN	metallic champagne	+\$0
EH	metallic bronze	+\$0
HF	inner tone light	+\$0
LT	light tone	+\$0
LU	soft white	+\$0
MS	metallic silver	+\$0
MT	medium tone	+\$0
SG	slate grey	+\$0
WL	sandstone	+\$0

V-Pull Storage Case *continued*

Sand Texture Paint

For textured paint on smooth steel (XS)

91	white	+\$0
98	studio white	+\$0
BK	black	+\$0
CL	cool grey neutral	+\$0
G1	graphite	+\$0
WN	warm grey neutral	+\$0

Step 6. Interior

For 64" high (64)

CR	coat rod	-\$148
NS4	4 shelves total	+\$0

Step 7. Lock

KA	keyed alike	-\$10
KC	keyed differently, chrome	+\$0
KD	keyed differently, black	+\$0

Storage Case Shelf

LG940.

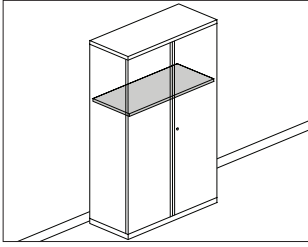

Tu® Metal Storage

Product Information

Description

This smooth-steel shelf fits into a 20"-deep Tu® storage case or overfile to provide additional shelf storage. Available in 3 widths. Shelf attachment clips included.

Actual shelf depth is 14⁷/₈". Actual shelf width is 27¹/₂", 33¹/₂", or 39¹/₂".

Dimensions

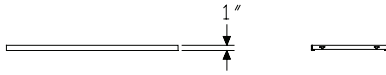
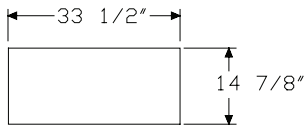

Specification Information

Step 1.

LG940.

Step 2. Width

30	30" wide
36	36" wide
42	42" wide

Prices for Steps 1-2.

LG940. 30	\$58
36	\$67
42	\$78

Step 3. Paint/Steel Type

SS	smooth paint on smooth steel	+\$0
XS	textured paint on smooth steel	+\$0

Step 4. Surface Finish

For smooth paint on smooth steel (SS)

98	studio white	+\$0
8Q	folkstone grey	+\$0
BU	black umber	+\$0
HF	inner tone light	+\$0
LT	light tone	+\$0
LU	soft white	+\$0
MT	medium tone	+\$0
SG	slate grey	+\$0
WL	sandstone	+\$0
CN	metallic champagne	+\$0
EH	metallic bronze	+\$0
MS	metallic silver	+\$0

Sand Texture Paint

For textured paint on smooth steel (XS)

91	white	+\$0
98	studio white	+\$0
BK	black	+\$0
CL	cool grey neutral	+\$0
G1	graphite	+\$0
WN	warm grey neutral	+\$0

Bookcase

LG500.

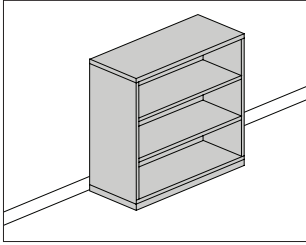

Product Information

Description

This freestanding bookcase provides storage and display space. It has a smooth-steel case and adjustable shelves. It includes 1 or more shelves, depending on height. Shelves adjust in 1¹/₄" increments. All bases have 3/4" leveling glides. Available in 3 widths and 4 heights.
Actual bookcase depth is 15". Actual width is 29¹/₂", 35¹/₂", or 41¹/₂".

Notes

The following chart shows the number of adjustable shelves in each bookcase and vertical clearance between shelves when evenly spaced:
Height—Shelves—Bottom space—Mid-space—Top space
26" h (27¹/₄" actual)—1 shelf—11⁷/₈"—n/a—10¹/₂"
38" h (39¹/₈" actual)—2 shelves—11⁷/₈"—12⁵/₈"—8⁷/₈"
51" h (51¹/₂" actual)—3 shelves—11⁷/₈"—(2) 12⁵/₈"—7¹/₂"
64" h (64⁷/₈" actual)—4 shelves—11⁷/₈"—(3) 12⁵/₈"—7³/₈"
Dimensional illustrations do not include all possible configurations.
Order additional bookcase shelf (LG950.) separately.

Dimensions

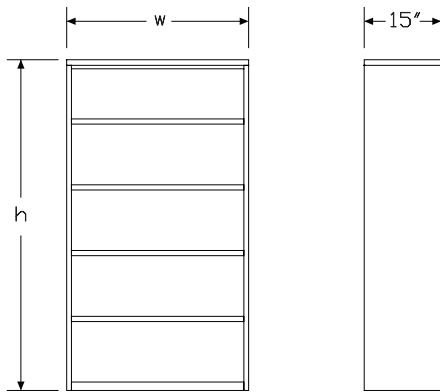

Specification Information

Step 1.

LG500.

Step 2. Width

30	30" wide
36	36" wide
42	42" wide

Step 3. Height

26	26" high
38	38" high
51	51" high
64	64" high

Prices for Steps 1-3.

	26	38	51	64
LG500. 30	\$908	969	1028	1087
36	\$1038	1096	1155	1214
42	\$1163	1223	1283	1341

Step 4. Paint/Steel Type

SS	smooth paint on smooth steel	+\$0
XS	textured paint on smooth steel	+\$0

Step 5. Surface Finish

For smooth paint on smooth steel (SS)

8Q	folkstone grey	+\$0
98	studio white	+\$0
BU	black umber	+\$0
CN	metallic champagne	+\$0
EH	metallic bronze	+\$0
HF	inner tone light	+\$0
LT	light tone	+\$0
LU	soft white	+\$0
MS	metallic silver	+\$0
MT	medium tone	+\$0
SG	slate grey	+\$0
WL	sandstone	+\$0

Bookcase *continued*

Tu® Metal Storage

Sand Texture Paint		
<i>For textured paint on smooth steel (XS)</i>		
91	white	+\$0
98	studio white	+\$0
BK	black	+\$0
CL	cool grey neutral	+\$0
G1	graphite	+\$0
WN	warm grey neutral	+\$0

Bookcase Shelf

LG950.

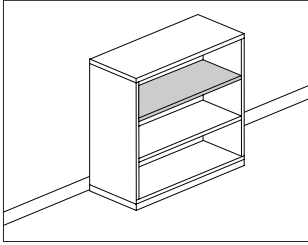

Product Information

Description

This smooth-steel shelf fits into a 15"-deep Tu® bookcase to provide additional shelf storage. Available in 3 widths. Shelf attachment clips included.

Actual shelf depth is 12³/₄".

Dimensions

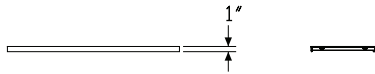
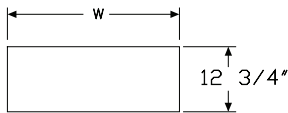

Specification Information

Step 1.

LG950.

Step 2. Width

30	30" wide
36	36" wide
42	42" wide

Prices for Steps 1-2.

LG950. 30	\$55
36	\$65
42	\$76

Step 3. Paint/Steel Type

SS	smooth paint on smooth steel	+\$0
XS	textured paint on smooth steel	+\$0

Step 4. Surface Finish

For smooth paint on smooth steel (SS)

8Q	folkstone grey	+\$0
98	studio white	+\$0
BU	black umber	+\$0
CN	metallic champagne	+\$0
EH	metallic bronze	+\$0
HF	inner tone light	+\$0
LT	light tone	+\$0
LU	soft white	+\$0
MS	metallic silver	+\$0
MT	medium tone	+\$0
SG	slate grey	+\$0
WL	sandstone	+\$0

Sand Texture Paint

For textured paint on smooth steel (XS)

91	white	+\$0
98	studio white	+\$0
BK	black	+\$0
CL	cool grey neutral	+\$0
G1	graphite	+\$0
WN	warm grey neutral	+\$0

Keyless Lock

MKL-H
 MKL-V
 MKS-H
 MKS-V

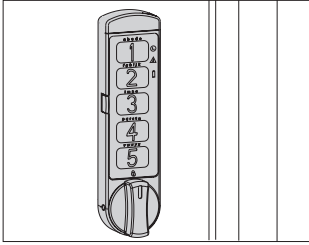

Tu® Keyless Locks

Product Information

Description

This keyless lock replaces an existing cam lock and is available in 2 mode options. Locker mode allows for a temporary code to be entered for each use, and station mode allows for repeated use with the same code. Multiple orientation options allow the keyless lock to be used with a variety of products.

Notes

Replacement battery is a 3-volt lithium CR2032 battery.
 Actual lock dimensions are 3.86"W x 1.00"H x 0.39"D.
 Meridian® standard pull 2600 series, the Tu® metal pedestal, and some Tu metal lateral files will not accommodate the width of the keyless lock.

Order the following products separately:

- Control key fob (MKL-CKF)
- User key fob (MKL-UKF)

This keyless lock can be found under the Meridian® product line code of MS.

Dimensions

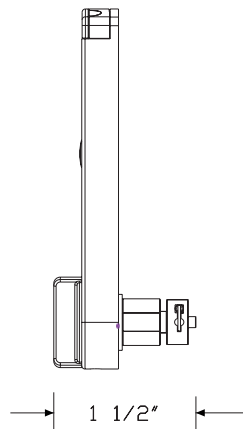
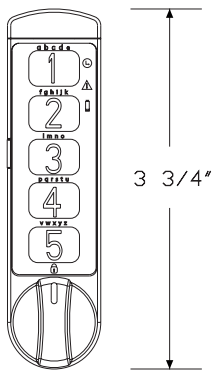
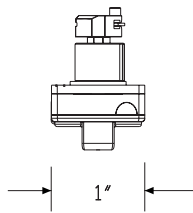

Specification Information

Step 1.

MK

Step 2. Mode

L- locker mode

S- station mode

Step 3. Orientation

HL horizontal, keypad facing left

HR horizontal, keypad facing right

VU vertical, keypad facing up

VD vertical, keypad facing down

Prices for Steps 1-3.

MKL-HL	\$209
MKL-HR	\$209
MKL-VU	\$209
MKL-VD	\$209
MKS-HL	\$209
MKS-HR	\$209
MKS-VU	\$209
MKS-VD	\$209

Step 4. Finish

OI silver <input type="checkbox"/>	+ \$0
BK black <input type="checkbox"/>	+ \$0

Keyless Lock, Control Key Fob

MKL-C



Product Information

Description

This key fob opens the keyless lock without using the numeric keypad.

Notes

Order the following products separately:

- Keyless lock (MK)
- User key fob (MKL-UKF)

This keyless lock, control key fob can be found under the Meridian® product line code of MS.

Dimensions

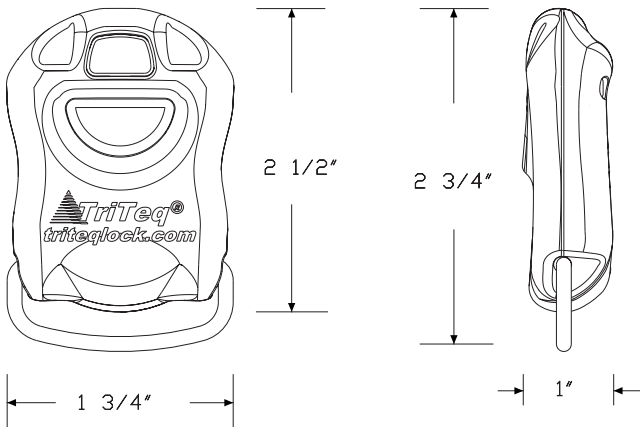

Specification Information

Step 1.

MKL-CKF A

\$180

Keyless Lock, User Key Fob

MKL-U



Product Information

Description

This key fob opens the keyless lock without using the numeric keypad.

Notes

Order the following products separately:

- Keyless lock (MK)
- Control key fob (MKL-CKF)

This keyless lock, user key fob can be found under the Meridian® product line code of MS.

Dimensions

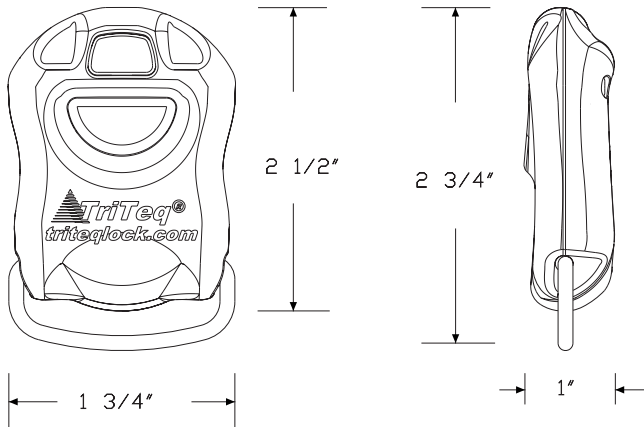

Specification Information

Step 1.

MKL-UKF A

\$180

Index by Product Name

Tu® Storage	
	page(s)
Arc Pull Add-On Overfile	86
Arc Pull Freestanding Lateral File	72
Arc Pull Freestanding Pedestal	8
Arc Pull Mobile Pedestal	20
Arc Pull Storage Case	132
Arc Pull Storage Tower	103
Arc Pull Support Pedestal	44
Arc Pull Surface-Attached Pedestal	32
Arc Pull Suspended Pedestal	55
Bar-Pull Add-On Overfile	84
Bar-Pull Freestanding Lateral File	69
Bar-Pull Freestanding Pedestal	5
Bar Pull Mobile Pedestal	17
Bar-Pull Storage Case	130
Bar-Pull Storage Tower	99
Bar Pull Support Pedestal	41
Bar Pull Surface-Attached Pedestal	29
Bar Pull Suspended Pedestal	53
Bookcase	139
Bookcase Shelf	141
Counterweight, Tu® Lateral File	97
Drawer Divider, Tu® Pedestal	125, 64
File Compressor, Tu®	129, 68
File Converter, Tu®	128, 67
File Drawer Organizer	124, 94, 63
Front-to-Back Filing Rail, Tu® Lateral File	93
Keyless Lock	142
Keyless Lock, Control Key Fob	143
Keyless Lock, User Key Fob	144
Label Holders-Snap In and Adhesive	98
Lateral File Add-On Cushion Top	92
Movable Divider, Meridian®, Quadrant® or Tu®	96
Pedestal Add-On Cushion Top	61
Side-to-Side Filing Rail, Tu® Lateral File	95
Stationery Divider, Tu® Pedestal	126, 65
Storage Case Shelf	138
Storage Organizer	62
Tu® File Top	90
Tu® Storage Tower Attachment Bracket	123
Utility Tray, Tu® Pedestal	127, 66
V-Pull Add-On Overfile	89
V-Pull Freestanding Lateral File	80
V-Pull Freestanding Pedestal	14
V-Pull Lateral File, with Open Shelf	82
V-Pull Mobile Pedestal	26
V-Pull Storage Case	136

V-Pull Storage Tower	110
V-Pull Storage Tower, No Wardrobe	116
V-Pull Support Pedestal	50
V-Pull Surface-Attached Pedestal	38
V-Pull Suspended Pedestal	59
V-Pull Wardrobe Cabinet	121
W-Pull Add-On Overfile	88
W-Pull Freestanding Lateral File	76
W-Pull Freestanding Pedestal	11
W-Pull Lateral File, with Open Shelf	78
W-Pull Mobile Pedestal	23
W-Pull Storage Case	134
W-Pull Storage Tower	107
W-Pull Storage Tower, No Wardrobe	113
W-Pull Support Pedestal	47
W-Pull Surface-Attached Pedestal	35
W-Pull Suspended Pedestal	57
W-Pull Wardrobe Cabinet	119

Index by Product Number

9LH5H	Label Holders-Snap In and Adhesive	page(s) 98	LQ14A.	Arc Pull Surface-Attached Pedestal	32
9LH7H			LQ14D.		
9M100	Movable Divider, Meridian®, Quadrant® or Tu®	96	LQ15A.	Arc Pull Support Pedestal	44
9M300			LQ15D.		
LG500.	Bookcase	139	LQ20A.	Arc Pull Freestanding Lateral File	72
LG692	Tu® Storage Tower Attachment Bracket	123	LQ20D.		
LG890.	Pedestal Add-On Cushion Top	61	LQ20L.		
LG891.	Lateral File Add-On Cushion Top	92	LQ300D	Arc Pull Storage Tower	103
LG901	File Drawer Organizer	124, 94, 63	LQ300L		
LG902.	Side-to-Side Filing Rail, Tu® Lateral File	95	LQ310D		
LG903.	Drawer Divider, Tu® Pedestal	125, 64	LQ310L		
LG904.	Front-to-Back Filing Rail, Tu® Lateral File	93	LQ400D	Arc Pull Storage Case	132
LG905	Stationery Divider, Tu® Pedestal	126, 65	LQ400L		
LG906	Utility Tray, Tu® Pedestal	127, 66	LQ410D	Arc Pull Add-On Overfile	86
LG907	File Converter, Tu®	128, 67	LQ410L		
LG908	File Compressor, Tu®	129, 68	LTPL-	Tu® File Top	90
LG909.	Counterweight, Tu® Lateral File	97	LTPV-		
LG910.	Storage Organizer	62	LV100.	V-Pull Freestanding Pedestal	14
LG940.	Storage Case Shelf	138	LV110.	V-Pull Mobile Pedestal	26
LG950.	Bookcase Shelf	141	LV130.	V-Pull Suspended Pedestal	59
LK10A.	Bar-Pull Freestanding Pedestal	5	LV140.	V-Pull Surface-Attached Pedestal	38
LK10D.			LV150.	V-Pull Support Pedestal	50
LK11A.	Bar Pull Mobile Pedestal	17	LV200.	V-Pull Freestanding Lateral File	80
LK11D.			LV260.	V-Pull Lateral File, with Open Shelf	82
LK13A.	Bar Pull Suspended Pedestal	53	LV300.	V-Pull Storage Tower	110
LK13D.			LV310.		
LK14A.	Bar Pull Surface-Attached Pedestal	29	LV320.	V-Pull Storage Tower, No Wardrobe	116
LK14D.			LV330.		
LK15A.	Bar Pull Support Pedestal	41	LV380.	V-Pull Wardrobe Cabinet	121
LK15D.			LV400.	V-Pull Storage Case	136
LK20A.	Bar-Pull Freestanding Lateral File	69	LV410.	V-Pull Add-On Overfile	89
LK20D.			LW100.	W-Pull Freestanding Pedestal	11
LK300D	Bar-Pull Storage Tower	99	LW110.	W-Pull Mobile Pedestal	23
LK300L			LW130.	W-Pull Suspended Pedestal	57
LK310D			LW140.	W-Pull Surface-Attached Pedestal	35
LK310L			LW150.	W-Pull Support Pedestal	47
LK400D	Bar-Pull Storage Case	130	LW200.	W-Pull Freestanding Lateral File	76
LK400L			LW260.	W-Pull Lateral File, with Open Shelf	78
LK410D	Bar-Pull Add-On Overfile	84	LW300.	W-Pull Storage Tower	107
LK410L			LW310.		
LQ10A.	Arc Pull Freestanding Pedestal	8	LW320.	W-Pull Storage Tower, No Wardrobe	113
LQ10D.			LW330.		
LQ11A.	Arc Pull Mobile Pedestal	20	LW380.	W-Pull Wardrobe Cabinet	119
LQ11D.			LW400.	W-Pull Storage Case	134
LQ11L.			LW410.	W-Pull Add-On Overfile	88
LQ13A.	Arc Pull Suspended Pedestal	55	MKL-C	Keyless Lock, Control Key Fob	143
LQ13D.			MKL-H	Keyless Lock	142

Index by Product Number *continued*

Index: Product Number

MKL-U	Keyless Lock, User Key Fob	144
MKL-V	Keyless Lock	142
MKS-H		
MKS-V		

20-Day or Less/Assigned Lead-Time Order Information

20-Day or Less and Assigned Lead-Time Programs

20-day or less and assigned lead-time products are designed for established Herman Miller dealers with pre-approved credit.

Products are distributed from multiple manufacturing facilities across the United States. All products and options not designated by an Assigned Lead-Time icon **A** will ship in 20 business days or less after being acknowledged by Herman Miller. Products and options designated by an **A** are on the assigned lead-time program and will ship in 20 days, less than 20 days, or more than 20 days from order acknowledgement.

Ordering Procedure

Please place orders through Order Manager. If this is not available to you, place orders through mail or fax. Verbal purchase orders will not be accepted.

Order Entry fax number for Passage®, 5000 Series, and Meridian® Filing and Storage: (616) 846 9236.

Order Entry fax number for all other products:
(616) 654 3085.

For more information, contact your Customer Care representative at:
(866) 854 3048 EXT 3400.

Shipments and Delivery

Per Herman Miller Terms and Conditions.

Changes and Cancellation

Per Herman Miller Terms and Conditions.



Keyed-Alike Information

Keyed-Alike Locks

All components with locks may be specified keyed alike. Products with keyed-alike locks will be shipped with lock chassis installed.

Installation of lock cylinders will be on-site according to instructions provided. Herman Miller, Inc., will not be responsible for lock cylinder installation.

When specifying product keyed-alike, include separate lines on your order for the lock cylinders.

For Action Office®, Ethospace®, Passage®, Quadrant®, Resolve®, and Supplemental products, list cylinder part number and key number (232092-XXX); select a key number (or numbers) between 226 and 427, excluding numbers 408 and 412.

The following products require a different lock cylinder part number. Specify UKY001-XXX for these products only; select a key number (or numbers) between 226 and 427, excluding numbers 408 and 412.

- A3013.
- A3053.
- G5180.
- G5181.
- G5280.

The keys provided in 232092-XXX and UKY001-XXX kits work with either cylinder type, provided the key numbers match.

For Tu® Storage, Canvas Office Landscape®, 5000 Series, and Meridian® Storage, see the following charts.

Keyed-alike locks are field installed.

To order keyed-alike locks for Action Office® Series 1 and 2 door panels, please contact Customer Care.

A master key can be used to open any lock on an attached or freestanding component. In addition, a removal key or lock change tool is required to remove lock plugs. Customers interested in ordering master keys, removal keys, or lock change tools should contact Customer Care.

For Canvas overhead and lower storage units, specify as follows:

Specification Code	Part Number	Color	Lock Series
KA	1B2JK7-XXX ¹	chrome	UM series 226-427

For Meridian Storage, Tu Storage, and 5000 Series desk components with pedestals, specify as follows:

Specification Code	Key Number	Color	Lock Series
KA	232092-XXX ¹	black	UM series 226-427
KA	1B2JK7-XXX ¹	chrome	UM series 226-427

For 5000 Series flipper door unit with bezel or credenza storage cabinet with bezel, specify as follows:

Specification Code	Key Number	Color	Lock Series
KA	232092-XXX ¹	black	UM series 226-427

Key Number:

XXX¹ = a key number between 226 and 427 (excluding 408 and 412)



Stain-to-Match Program

Stain-to-Match Program

Program Overview

The Stain-to-Match program gives you the option of using veneer finishes that are not listed in the standard offering. The program allows Herman Miller to match a customer's existing recut or natural veneer, or create a new finish that is unique to an installation.

Specific information on approval, ordering, pricing, and warranty for the Stain-to-Match program is listed below. Questions and requests for assistance may be directed to Herman Miller Options at:

(800) 654 3910

Ordering Products with Stain-to-Match Veneers

1. Fill out the Options Stain-to-Match Request Form and send along with a color sample (2" x 3" minimum) to the Herman Miller Options Applications Team at the address provided on the form. The form can be found on Omni.
2. Within 7-10 working days, Herman Miller Options will send a sample of the color-matched stain on Herman Miller veneer to the requester for the customer's signed approval.
3. If the sample meets the customer's approval, sign the reverse side of the sample, scan and email the approval to:
options@hermanmiller.com.
4. After the stain has been approved, a formal quotation with special number and pricing can be provided, or the product can be specified through the Vary Easy program, if available. Work with the Options team on final product needs and how to specify.
5. A purchase order can then be placed.

Stain-to-Match Warranty

Herman Miller warrants its products to be free from defects in craftsmanship from the date of delivery for the applicable warranty period. Herman Miller is responsible for the physical properties of the veneers available through the Stain-to-Match program, which include:

- STA: Stain-to-Match on Recut Ash
- STB: Stain-to-Match on Beech
- STC: Stain-to-Match on Cherry
- STD: Stain-to-Match on Oak
- STK: Stain-to-Match on Reltech Anigre (Geiger)
- STM: Stain-to-Match on Recut Mahogany
- STP: Stain-to-Match on Maple
- STU: Stain-to-Match on Walnut (Geiger)

See your specification tool for product specific finish offering limitations.



Customer's Own Material/ Customer's Own Leather Order Information — Cushion Tops

Customer's Own Material/Customer's Own Leather

Program Overview

The Customer's Own Material (COM) and Customer's Own Leather (COL) program gives you the option of using textiles other than those listed. Herman Miller will test textiles for application to Herman Miller products and will process orders for those with approved COM/COL textiles only. COM/COL are assigned lead time textiles.

Omni lists an overview of fabrics and leathers that have been tested and indicates whether or not they were approved for application to Herman Miller products.

Specific information on the terms and conditions, testing, approval, and ordering process for COM/COL is listed below. Questions about the COM/COL program and requests for assistance may be directed to your COM representative at:

(616) 654 3400

(866) 854 3048 EXT 6543400

Customer's Own Material/Customer's Own Leather Warranty

Herman Miller does not warrant COM/COL textiles. COM/COL textiles are tested for application only; they are not tested for performance. The Herman Miller warranty does apply to the underlying products.

Suppliers of COM/COL textiles are responsible for color consistency within commercial tolerances, UV stability, and resistance to soiling and perspiration.

Customer's Own Material/Customer's Own Leather Pricing

COM is a Category 1 fabric. There are no application charges for COM fabrics. COL is a Category 7 textile; refer to prices on specific products to determine the application charge.

Ordering and payment for COM/COL textile yardage are the responsibility of the customer and the textile supplier.

If desired, Herman Miller will purchase COM textiles directly from True Textiles, C.F. Stinson, Luna Textiles, Maharam, and Momentum Textiles to simplify ordering and shipment. For this service, refer to the Supplier Connection program.

Application Note

Herman Miller does not guarantee that Customer's Own Material (COM) fabric patterns will align across panels/tiles or from one screen to the next. We also do not guarantee that COM fabric designs will be positioned consistently in the same location across several panels, tiles, or screens.

Textile Approval

1. Select a COM/COL textile.
2. If your textile is not listed on Omni, obtain a test number from a COM representative at (616) 654 3400. You can also submit your request within Omni. Please have the following information ready before calling: textile name, number, pattern, and the product you will apply it to.
3. Herman Miller will notify you of approval or disapproval within 4 days from receipt of the test yardage.

Customer's Own Material/ Customer's Own Leather Order Information — Cushion Tops

continued

Ordering Products with COM/COL

1. Refer to the specific products to determine the yardage required for COM/COL textiles.
2. If your textile is not listed on Omni, call a COM representative at (616) 654 3400 or (866) 854 3048 EXT 6543400. The representative will assign an identification number for your textile (ID#) and will verify yardage requirements for your order. Yardage requirements are based on directional, 54"-wide textiles. Additional yardage may be needed due to the unique characteristics of a textile.
3. Enter your order on Order Manager in Omni.
4. Upon receipt of your purchase order, Herman Miller will send you a PO acknowledgment.
5. Arrangements must be made for the textiles to be shipped from the supplier to Herman Miller for application to the seating products. See Omni for shipping procedures and current shipping addresses or contact a COM representative at (616) 654 3400 or (866) 854 3048 EXT 6543400.

Products will be scheduled for production when COM/COL textiles are received at Herman Miller. Standard lead times in effect at that time will apply.

Note: If textiles are to be purchased directly by Herman Miller through the Supplier Connection program, Herman Miller will handle the ordering and shipping process and will schedule your order for production upon receipt of your purchase order (dependent on textile availability). Refer to the Supplier Connection program for more information.

Supplier Connection

Program Overview

The Supplier Connection program is a service offered by Herman Miller to purchase approved COM textiles directly from True Textiles, C.F. Stinson, Luna Textiles, Maharam, and Momentum Textiles. When you select a textile through this program, Herman Miller will facilitate the ordering, scheduling, and shipment of the textile directly with the supplier.

Suppliers included in the Supplier Connection program keep an active inventory of textiles that are pre-approved for application to Herman Miller products. Pre-approval applies only to the suitability of a textile for manufacturing and application to a Herman Miller product. Omni provides an overview of fabrics that have been tested and indicates whether or not they were approved for application to Herman Miller products.

Specific information on the terms and conditions, testing, approval, and ordering process for the Supplier Connection program is listed below. Questions and requests for assistance may be directed to your COM representative at:

(616) 654 3400
(866) 854 3048 EXT 6543400

Supplier Connection Warranty

Textiles purchased by Herman Miller through the Supplier Connection program are COM and are not warranted by Herman Miller. COM textiles are tested for application only; they are not tested for performance. The Herman Miller warranty does apply to the underlying products.

Suppliers of COM textiles are responsible for color consistency within commercial tolerances, UV stability, and resistance to soiling and perspiration.

Customer's Own Material/ Customer's Own Leather Order Information — Cushion Tops

continued

Supplier Connection Pricing

Textiles purchased by Herman Miller through the Supplier Connection program are COM. COM is a Category 1 fabric. There are no application charges for COM fabrics.

Payment for textiles purchased by Herman Miller through the Supplier Connection program is the responsibility of the customer or dealer. Herman Miller will invoice the order at the supplier's prices published at the time of the order.

Textile Approval

1. Refer to Omni to identify the approval status of the textile. If your textile is not listed, contact the COM Department to request testing for application to Herman Miller products.
2. Herman Miller will notify you of approval or disapproval in approximately 4 days from receipt of the test yardage. If the textile is approved, it will be assigned a COM identification number.

Ordering Products with Supplier Connection COM

1. Identify and include the following information on your purchase order:
 - Product number and option
 - Herman Miller's COM identification number
2. Enter your order on Order Manager in Omni.
3. Upon receipt of the purchase order, Herman Miller will process your order and send you a PO acknowledgment. Herman Miller will determine the yardage required to produce your product and will order and schedule for delivery the required textile. Standard lead times in effect at the time the textile is allocated at the supplier will apply to products ordered through this program.



For more information about our products and services or to see a list of dealers, please visit us at HermanMiller.com or call (800) 851 1196.

© 2019 Herman Miller, Inc., Zeeland, Michigan

Distribution Rights

Working together since 1956, Herman Miller and Vitra are the authentic sources of designs by Charles and Ray Eames, Alexander Girard, and George Nelson. All the designs shown in this book are protected by law. Herman Miller has obtained all rights to make and sell these designs. Also, Herman Miller holds exclusive worldwide manufacturing and distribution rights for these products with the following exceptions:

Charles and Ray Eames, George Nelson, and Alexander Girard—Worldwide distribution rights for furniture in all areas except Europe and the Middle East. For those areas, please contact Vitra.

Isamu Noguchi—Worldwide distribution rights for the Noguchi Rudder Table. Distribution rights for the Noguchi Table in North America and Central America only. For all other areas, please contact Vitra.

Magis—Exclusive distribution rights in the US and Canada. For all other areas, please contact Magis.

Mattiazzi—Exclusive distribution rights in the US and Canada. For all other areas, please contact Mattiazzi.

® **HermanMiller**, , Action Office, Aeron, Aside, Avive, Canvas Office Landscape, Capex, Celle, Co/Struc, Eames, Embody, Equa 2, Ergon 3, Ethospace, Exclave, Fine-Tune, FlexFront, Formcoat, Ground Cloth, Herman Miller Healthcare, Layout Studio, Maharam, Meridian, Mirra, Passage, Pellicle, Perspectives, PostureFit, Quadrant, Resolve, Sayl, Setu, Thrive, Tu, Y-Tower, and Z-Axis are among the registered trademarks of Herman Miller, Inc., and its owned subsidiaries.

™ AireWeave, Bubbletack, Cellular Suspension, Compass, Connect, Cosm, DOT, Durawrap, Everywhere, Flex-Edge, Hopsak 2, Intent, Iota, Keyless Entry, Latitude, Lino, Lyris 2, Mora, Motia, Multiscrim, Nelson, Nevi, Pedastools, Plex, Renew, Stackable, Swoop, TriFlex, Twist, Verus and Vista are among the trademarks of Herman Miller, Inc., and its owned subsidiaries.

®Chemsurf® is a registered trademark of Wilsonart International.

Corian® is a registered trademark of E.I. du Pont de Nemours and Company Corporation.

FLEXNET™ is a trademark of Milliken & Company.

Floor Saver Glide® is a registered trademark of Carpin Manufacturing, Inc.

Geiger® is a registered trademark of Geiger International.

Microsoft® and Natural® Keyboard are registered trademarks of Microsoft Corporation.

Place Textiles® is a registered trademark of Place Textiles.