

January 3, 2011
Updated August 27, 2019
800-424-2432





| | | |
|--|---|-----|
| Ordering C.O.M., C.O.L., and C.O.V. | | |
| | BONDUEL, GREEN BAY, ONTARIO, and TUPELO | 2 |
| | HIGH POINT | 4 |
| | Shipping Location | 6 |
| <hr/> | | |
| Stack/Nesting | Apply® | 8 |
| | Grazie® | 16 |
| | Maestro® | 40 |
| | Matrix® | 46 |
| | Opt4® | 54 |
| | Plaza™ | 82 |
| | Rapture® | 88 |
| | Strive® | 102 |
| | Strive® High Density | 142 |
| | Strive® Stack | 150 |
| | Torsion® on the Go! | 162 |
| | Torsion® | 170 |
| | Torsion Air® | 184 |
| | Versa® Basic | 200 |
| | Versa® Conference | 206 |
| | Versa® Standard | 214 |
| | Versa® XL | 236 |
| | Xylon® | 244 |
| <hr/> | | |
| Guest Seating | Bantam™ Chair | 250 |
| | Itoki DP Chair | 256 |
| | Jubi™ Chair | 262 |
| <hr/> | | |
| Index | | 268 |

Ordering C.O.M., C.O.L., and C.O.V.

BONDUEL, GREEN BAY, ONTARIO, and TUPELO

How to Specify C.O.M. Upholstery

Textile designs often have intricate patterns. Not all individuals will interpret fabric direction in the same manner.

As a standard procedure, KI cuts fabrics off the roll in a horizontal fashion as shown in Diagram A at the right. By cutting in this fashion, most waste is eliminated. Our requirements for yardage in this book are based on this type of cutting. When directional or patterned fabrics are used, they often require more yardage than solid colors.

By providing KI with a completely filled-out copy of the form on this page, we will be able to expedite your order. We find it particularly helpful with directional or patterned upholstery material. It is critical that copies of this form accompany test quantities as well as production quantities of C.O.M.

C.O.M. must be supplied in continuous yardage.

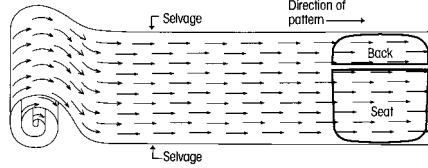

C.O.M., C.O.L. and C.O.V. Testing

KI will require for testing actual yardage to upholster one chair. The testing requirements depend on which chair you have selected on your order.

Test samples will be applied to the order and will be held for 6 months if needed. After 6 months, the sample can no longer be applied to your order. For all products to be tested, send test samples for approval to:

KI
Attn: C.O.M. Specialist
1687 Westminster Drive, Gate 3
Green Bay WI 54302

To expedite the procedure, attach a copy of the "C.O.M. Information Form" on this page.

All C.O.M., C.O.L. and C.O.V. must be labeled with the purchase order number.

C.O.M., C.O.L. and C.O.V. Production

Customer's fabrics and leathers must be approved prior to acceptance for production. Upon test approval, a 1" square sample swatch of upholstery material must accompany the order. KI assumes no responsibility for wear, defects or performance of customer's own fabrics, vinyl or leather. C.O.M., C.O.L. and C.O.V. orders are available on a deferred delivery basis.

Orders for production of C.O.M., C.O.L. and C.O.V. upholstered products are not scheduled for processing until upholstery material is received. Upon receipt, KI will provide an acknowledgement and an estimated shipping date.

KI recommends that leather be ordered in yardage. Leather must be usable. The outer edges cannot be calculated as square feet or yardage.

The C.O.M., C.O.L. and C.O.V. yardage requirements accompanying products in the pricing section are for 10 chairs/seats or less, 54" wide nondirectional material. On larger orders, less material is required.

For exact production yardage requirements, call 1-800-424-2432, ext. 2707.

C.O.M., C.O.L. and C.O.V. Order Processing

For products shipped from Green Bay, WI facility, ship upholstery material to:

KI
Attn: C.O.M. Storage
1687 Westminster Drive, Gate 3
Green Bay, WI 54302

For products shipped from Tupelo, MS facility ship material to:

KI Tupelo
Attn: C.O.M. Storage
2112 South Green Street
Tupelo, MS 38801

For products shipped from Bonduel, WI facility, ship material to:

KI
Attn: C.O.M. Storage
204 West South Street
Bonduel, WI 54107

For products shipped from Ontario, CA facility, ship material to:

Avail/Impress/Kismet/Medical & Laboratory Stools/Pilot
Attn: C.O.M. Storage
1110 S. Mildred Ave.
Ontario, CA 91761

Treated Materials

If C.O.M. requires processing such as Scotchgard® or acrylic backing, it often shrinks. To prevent delays in delivery or back ordering due to shrinkage, please have your processor remeasure after processing and assure adequate yardage shipment.

Split Orders

If a portion of the shipment which does not require C.O.M., C.O.L. or C.O.V. applications is to be processed and shipped early, KI will enter the order immediately at your request. These split shipments are subject to minimum order changes.

Contact the C.O.M. Specialist at 1-800-424-2432, ext. 2707, with questions or to verify a split order.

Excess Upholstery Material

KI will dispose of excess upholstery material at the time of shipment unless expressly requested to return it with the product shipment.

Cancelled or Changed Orders

KI assumes no responsibility for extra C.O.M., C.O.L. or C.O.V. material due to a change of upholstery or cancellation of an order. It is the customer's responsibility to arrange for return of this material.

Intricate Patterns

In the event of specific requirements for positioning of intricate patterns or pattern repeats on seats and backrests, provide a sketch noting requirements, as in Diagram B, along with materials for testing, and with the order.

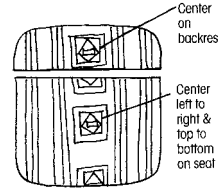

Diagram B

C.O.M., C.O.L. and C.O.V. Information Form

A copy of this form should accompany test requests and production orders. Please fill it out completely, and, if your order has been acknowledged, provide the acknowledgement number.

Purchasing Agent (Dealer or buying organization)

Attention

Address

City

State

Zip

Project Name

Type of seating and number of units of each type

Please see information below and check the appropriate box.

Submitted for testing.

Test approved. Submitted for production.

Purchase Order Number

KI Acknowledgement Number

In all instances, send this form to the C.O.M. Specialist.

A Selvage Top and Bottom



B Selvage Side and Side

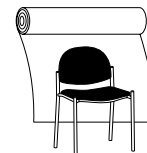



Ordering C.O.M., C.O.L., and C.O.V.
BONDUEL, GREEN BAY, ONTARIO, and TUPELO

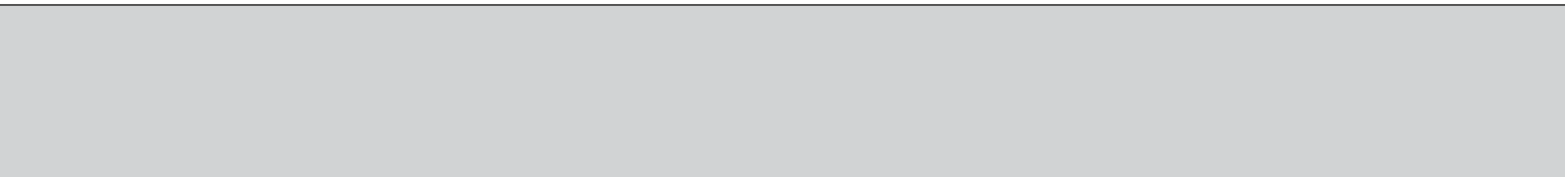

Ordering C.O.M., C.O.L., and C.O.V.

HIGH POINT

Customer's Own Material ■

Specifications Form

January 2017

All fabrics, including COM, COL, KOM and in grades will be applied at the factory's discretion. If a pattern or stripe is to be applied in a certain direction, the customer MUST specify this in writing on the P.O. and attach a sample of the fabric with it running in the application direction to the P.O. Specifying fabric direction may increase the amount of COM or KOM yardage required. Check with KI Customer Service to see if an increase in yardage is necessary BEFORE specifying, ordering and sending COM and COL to the factory or having KOM quoted.

ALL C.O.M AND C.O.L SHIPMENTS MUST BE PREPAID TO: KI
217 Feld Avenue
High Point, NC 27263

COM and COL must be identified as follows:

1. Name and address
2. Your purchase order number
3. Our style number to which fabric is to be applied
4. Supplier name and fabric name, number, and color

COLLECT SHIPMENTS WILL BE REFUSED.

SHIPMENT SCHEDULE WILL BE GIVEN WHEN ALL FABRIC IS RECEIVED FOR ENTIRE ORDER

YARDAGE REQUIREMENTS LISTED IN PRICE LIST ARE BASED ON PLAIN GOODS 54" WIDE. Fabrics less than 54" wide, or those requiring matching (stripes, plaids, prints, large patterns) will require additional yardage based on the fabric used and the item ordered. CONSULT MATRIX BELOW FOR ADDITIONAL YARDAGE NEEDED.

C.O.M. INCREASE MATRIX (The yardage matrix is also applicable to any reservations of KI Ingrade, Pallas, or KOM upholsteries).

This table is a general guide.

| FABRIC WIDTH | PLAIN FABRIC | UNDER 7" REPEAT | 8"-13" REPEAT | 14"-21" REPEAT | 22"-27" REPEAT | 28"-33" REPEAT | 34"-40" REPEAT | 41"-48" REPEAT |
|--------------|--------------|-----------------|---------------|----------------|----------------|----------------|----------------|----------------|
| 54" | 0 | 20% | 25% | 30% | 45% | 55% | 70% | 80% |
| 51"-53" | 15% | 25% | 30% | 35% | 50% | 60% | 80% | 90% |
| 48"-50" | 20% | 30% | 35% | 40% | 55% | 65% | 85% | 95% |
| 45"-47" | 30% | 45% | 50% | 55% | 60% | 80% | 90% | 100% |
| 36"-44" | 50% | 65% | 70% | 75% | 80% | 100% | 110% | 120% |

FABRIC WITH DOUBLE REPEAT: IF USING A FABRIC WITH A DOUBLE REPEAT, PLEASE FOLLOW THIS FORMULA: TAKE THE TOTAL AMOUNT OF THE LARGER AND HALF OF THE SMALLER REPEAT; ADD TOGETHER TO FIND THE CORRECT OVERALL REPEAT. EXAMPLE: 10" VERTICAL WITH 14" HORIZONTAL WOULD BE $14+5=19$.

IF FABRIC COMES IN ON MULTIPLE ROLLS, ONE ADDITIONAL YARD PER ROLL NEEDS TO BE ADDED TO THE YARDAGE REQUIREMENT.

SPECIAL NOTE: WE CAN ASSUME NO RESPONSIBILITY FOR THE DURABILITY OR TAILORING QUALITY OF CUSTOMER FURNISHED COVERINGS (C.O.M.) OR KOM. KOM: is fabric that KI will purchase for you at jobber's price (net) plus a nominal charge for handling, shipping, and managing.





Customer's Own Material ■

Specifications Form

January 2017

ADDITIONAL NOTES:

- Orders cannot go into production without the information listed at right.
- Attach memo sample to this approval sheet.
- If your order has been placed, list PO# _____
- The cost of the COM sample will be paid by the client.
- Even after preliminary approval, KI reserves the right to reject COM/COL if necessary when the quality is not satisfactory for the product to be upholstered. KI assumes no responsibility for its overall appearance, flammability, durability, color fastness or any other quality after upholstered on a KI product.

ALL COM MUST BE APPROVED.

Photocopy this form and submit with COM fabric for approval:

(This fabric approval is for the purpose of advising how to apply your COM fabric, verify yardage required, and suitability.)

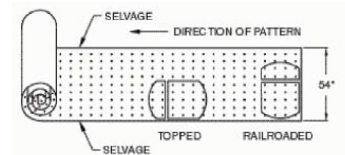

YOUR COMPANY NAME _____

PHONE _____ FAX _____

Material Supplier _____

Material Name _____ Number _____

Material Color _____ Width _____

Vertical Repeat _____ Horizontal Repeat _____

Fiber Content _____

Direction Stripe/Pattern to be applied _____

COM TO BE USED ON THE FOLLOWING:

| QTY | PRODUCT NAME/NUMBER |
|-------|---------------------|
| _____ | _____ |
| _____ | _____ |
| _____ | _____ |
| _____ | _____ |
| _____ | _____ |



Ordering C.O.M., C.O.L., and C.O.V.

Shipping Location



C.O.M. SHIPPING LOCATION

Architectural Walls

Genius Walls MN

Casegoods

Dante Benches AG

Aristotle Tackboards MN

Classroom Furniture

360° Classroom Furniture BW

Intellect Wave Chairs GB

Learn2 GB

Desking

700 Series Desking KP

Balance Overheads MN

Genesis Desking MN

True Desking KP

Universal Overheads MN

WorkZone Desking MN

Files & Storage

700 Series Pedestal Cushion GB

Connection Zone Pads BW

U-Series Pedestal Cushion GB

Tattoo BW

Fixed Seating

Concerto Auditorium Seating BW

Single Pedestal Seating GB

Jury Base Seating GB

Lancaster Auditorium Seating BW

Sequence Seating GB

University Seating GB

Panel Systems

All Terrain KP

Balance Overheads MN

System 3000 MN

Universal Overheads MN

Wireworks MN

Unite MN

Residence Hall Furniture

RoomScope Furniture MN

Screens

All Terrain KP

Connection Zone BW

True/Volition KP

Genesis KP

Tattoo MN

Seating

100 Series Folding Chairs BW

300 Series Folding Chairs BW

600 Series Stools BW

700 Series Folding Chairs BW

Affina Collection HN

Arisa Lounge HN

Altus Task Chairs TM

Apply Stack Chairs GB

Auditorium Folding Chairs BW

Avail Task Chairs OM

Bantam Guest Seating HN

Calida Lounge Seating TM

Cinturon Lounge Seating HN

Connection Zone Privacy Booths HN

Doni Collection GB

FourC Seating TM

Front Row Seats (Silk Screening) BW

GateOne Public Seating BW

Grazie Seating GB

Hiatus Sleeper Bench HN

Hub Modular Lounge Seating HN

Impress Task Chairs OM

Impress Ultra Task Chairs OM

Jessa Lounge Seating HN

Jubi Guest Chair GB

Katera Guest Chair TM

Kurv Benches HN

LaResta Day Beds HN

Lyra Lounge Seating HN

Maestro Stack Chairs GB

Matrix Stack Chairs GB

Medical & Laboratory Stools OM

MyWay Seating HN

Neena Benches HN

Oath Task Chairs and Stools TM

Opt4 GB

Perth Multiple & Healthcare Seating HN

Perth II Healthcare Seating HN

Pilot Task Chairs OM

Promenade Seating System BW

Rapture Stack Chairs & Stools GB

Ruckus GB

Rose Healthcare BW

Sela Lounge Seating HN

Sift Task Chairs TM

Silhouette Stack Chairs & Stools TM

Soltice Metal Collection HN

Soltice Multiple, Healthcare & Guest HN

Soltice II Healthcare Seating HN

Strive Multiple, Stack & Task GB

Sway BW

Tattoo HN

Tea Cup Lounge Seating HN

Torsion-on-the-Go! Nesting Chairs GB

Torsion Air Stack and Task Seating GB

Torsion Stack and Task Seating GB

Versa Stack Chairs & Stools GB

Voyant Task Chairs TM

Voz Guest Chairs TM

KI Manufacturing Sites - Customer's Own Material Shipment Manufacturing Site Addresses

AG

Contact KI at
1-800-424-2432

GB

KI Green Bay
Attn: COM Storage
1687 Westminster Drive - Gate 3
Green Bay, WI 54302

KP

KI Pembroke
Attn: COM Storage
1000 Olympic Dr.
Pembroke, Ontario K8A6X7

MN

KI Manitowoc
Attn: COM Storage
1400 S. 41st St.
Manitowoc, WI 54220

BW

KI Bonduel
Attn: COM Storage
204 West South St.
Bonduel, WI 54107

HN

KI High Point
Attn: COM Storage
217 Feld Avenue
High Point, NC 27263

OM

KI
Attn: COM Storage
1110 S. Mildred Ave.
Ontario, CA 91761

TM

KI Tupelo
2112 South Green St.
Tupelo, MS 38804



Ordering C.O.M., C.O.L., and C.O.V.
Shipping Location

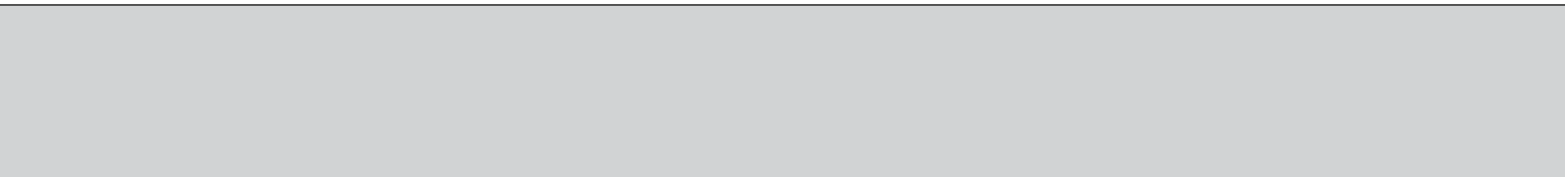

Stack/Nesting

Apply® General Information



**Four-Leg Chair
(ALNAU)**



**Sled Base Chair
(ASNAU)**



**High Back Cafe Stool
24" or 30" Seat Height
(ALHSP)**



**Low Back Cafe Stool
24" or 30" Seat Height
(ALLSP)**

**Transport Dolly
(ACD.BL)**

| Features | | | | | |
|---|------------------------|------------------------|--|--|---------|
| Stackable | • | • | | | |
| Molded plywood, optional upholstered seat pad | • | • | • | • | |
| 300 lb tested | • | • | • | • | |
| General Dimensions | | | | | |
| Seat width | 17-1/2" | 17-1/2" | 17-1/2" | 17-1/2" | |
| Seat depth | 17-3/8" | 17-3/8" | 17-3/8" | 17-3/8" | |
| Seat height (upholstered add 1/2") | 17-1/2" | 17-1/2" | 24" Model: 23-3/4" 30" Model: 29-3/4" | 24" Model: 23-3/4" 30" Model: 29-3/4" | |
| Overall Dimensions | | | | | |
| Width | 20-1/4" | 20" | 24" Model: 17-3/4" 30" Model: 18-3/4" | 24" Model: 17-3/4" 30" Model: 18-3/4" | 21-1/4" |
| Depth | 25 1/4" | 24 3/4" | 24" Model: 22-1/2" 30" Model: 23-3/4" | 24" Model: 22-1/2" 30" Model: 23-3/4" | 29" |
| Height | 32-1/2" | 32-1/2" | 24" Model: 38-3/8" 30" Model: 44-3/8" | 24" Model: 30" 30" Model: 36" | 15-1/2" |
| Stacking on Dolly | | | | | |
| Width | 20-1/4" | 20-1/4" | | | |
| Depth | 43" | 43" | | | |
| Quantity/height (plywood) | 15 Chairs/63-1/4" High | 15 Chairs/63-1/4" High | | | |
| Quantity/height (upholstered) | 6 Chairs/48" High | 6 Chairs/48" High | | | |
| Stacking on Floor | | | | | |
| Width | 20-1/4" | 20" | | | |
| Depth | 32-1/2" | 32" | | | |
| Quantity/height (plywood) | 6 Chairs/43" High | 6 Chairs/43" High | | | |
| Quantity/height (upholstered) | 6 Chairs/45-1/2" High | 6 Chairs/45-1/2" High | | | |

SPECIFICATIONS

Shell

One-piece contoured wood shell is constructed of formed plywood, .460"-.480" thick, 7-ply maple and poplar construction. The mold-formed seat and back provide for comfort and strength. Top/bottom and front/back surfaces are vertical grade postforming, product type 335, high-pressure laminate thickness of .028". Standard finish is #38 or #60 with a sanded, waxed edge. The wood shell is supported by four plywood circular disks and 1/4"-20 t-nuts bonded with construction-grade adhesive and fastened to a variety of base structures with four 1/4"-20x1/2" thread-locking screws. The chair perimeter is designed such that it provides a feature to support backpacks or courier bags. Shells are available in wood grain laminates or solid laminates.

Frame

Legs are formed from 3/4" OD x 13-gauge tubular steel. The seat plate is formed from 12-gauge steel and reinforced with 7/16" diameter wire crossmembers. All joints are welded. The frames are finished in either baked-on electrostatically-applied 30 degree gloss epoxy powder coating, or bright nickel-chrome plating. An injection-molded polypropylene shroud finishes the underside of the assembly, and provides a contoured surface for stacking. Sled base or 4-leg chairs stack 6-high on the floor.

Upholstered Seat

As an option, shells may be equipped with an upholstered seat pad. Urethane foam is attached to a formed plywood upholstery liner, then upholstered using a drawstring process. The foam is a nominal 1/2" thickness. The pad assembly is attached to the shell using 10-24 screws, engaging T-nuts in the liner.

Glides

4-leg chairs and stools have the option of a swivel glides with a stainless steel contact surface or a nylon glide. Standard sled chairs have no glides, but optional glides may be ordered. The optional glides are attached to the sled tube using screws and are available in black nylon, natural nylon, non-skid, or capped in stainless steel.

Cafe Stool

Available in nominal 24" and 30" seat heights and are not stackable. Legs are formed from 3/4" OD x 13-gauge tubular steel. The seat plate is formed from 12-gauge steel and reinforced with 7/16" diameter wire crossmembers. All joints are welded. The frames are finished in either baked-on electrostatically-applied 30 degree gloss epoxy powder coating or bright nickel-chrome plating. An injection-molded polypropylene shroud finishes the underside of the assembly. Stool frames have an added footing made of 1/2" diameter steel wire.

Stacking Vinyl, Polyurethane, and Imitation Leather Upholstered Chairs

It is recommended that chairs to be stacked be covered in material other than vinyl, polyurethane, or imitation leather as an impression in the seat may result. KI does not warrant the effects of stacking on stock or C.O.M. vinyl, polyurethane, or imitation leather upholstery.

Transport Dolly

Frame construction is welded tubular steel with black powder-coat finish and 5" wheels (two swivel and two fixed). The dolly fits 4-leg or sled-base chairs and has a capacity of fifteen wood chairs or six upholstered.

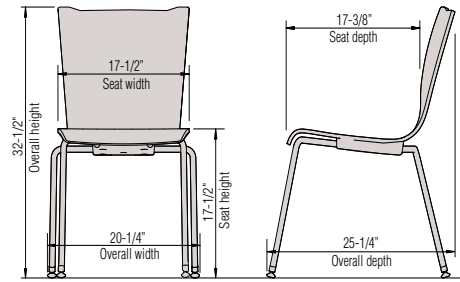

Apply Four-Leg Chair

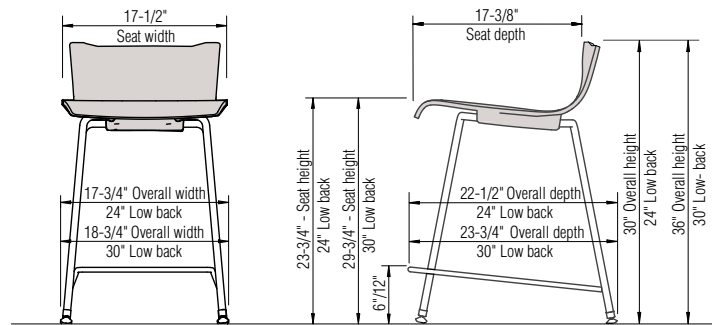

Apply 24\"/>

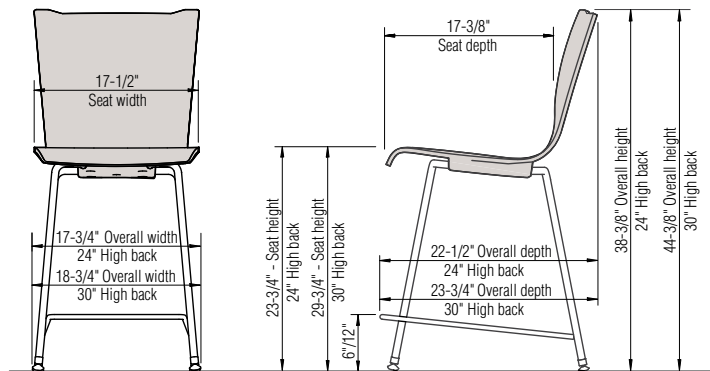

Apply 24\"/>

1687 Westminster Drive - Gate 3
Green Bay, WI 54302

INFORMATION

INFORMATION

C.O.M. Testing and Production Requirements

Not all materials are suitable for upholstering this product. A 1 yd. x 54" sample must be submitted and approved prior to acceptance of an order. Upholstered only and cushioned/upholstered chairs must be tested separately. If the fabric is directional in pattern or weave, the direction must be indicated on the submitted sample, and additional yardage may be requested. Customer's own vinyl cannot be used on this product.

Fabric Disclaimer

Fabric will be applied as swatched by the fabric manufacturer. Fabric that is required to be applied differently than is swatched will need a Special Cost Request written specifying the direction the fabric is to be applied. The posted standard lead time will apply to the Special Cost Request.

Warranty

Refer to KI Terms & Conditions document or visit www.ki.com

Test samples must be sent to:

KI
Attn: C.O.M. Specialist

Stack/Nesting

Apply® Color Options

Frame Color

| | |
|---------------------------|----|
| Antique Vein | AV |
| Black | BL |
| Blue Grey | GR |
| Bronze Metallic | ZM |
| Cayenne | CY |
| Champagne Metallic | CM |
| Chocolate | CT |
| Chrome | CH |
| Cool Grey | CG |
| Cottonwood | CO |
| Espresso Metallic | EX |
| Flannel | FN |
| Grass Green | GN |
| Light Tone | LG |
| Mardi Gras | MG |
| Misty Brown | MY |
| Nemo | NE |
| Nickel Vein | NK |
| Nordic | ND |
| Poppy Red | PR |
| Purple Haze | PH |
| Rubber Ducky | RK |
| Sand | SA |
| Sky Blue | SK |
| Splash | SH |
| Starlight Silver Metallic | SX |
| Surf's Up | SP |
| Ultra Blue | UB |
| Warm Grey | WG |
| Wet Sand | WS |
| Zesty Lime | ZL |

Laminate Color - Shell

| | |
|--------------------|------|
| Black | SLBK |
| Cherry Storm | SLCX |
| Cocobala | SLCC |
| Coffee Bean | SLCB |
| Dove Grey | SLDG |
| Florence Walnut | SLFC |
| Frosty White | SLFW |
| Grey | SLGE |
| Hollyberry | SLHY |
| Island | SLID |
| Italian Silver Ash | SLIT |
| Kensington Maple | SLKM |
| Lapis Blue | SLLB |
| Monticello Maple | SLMT |
| North Sea | SLNA |
| Ocean | SLON |
| Orange Grove | SLOE |
| River Cherry | SLRY |
| Sterling Ash | SLAZ |
| White Sand | SLWN |
| Windsor Mahogany | SLWY |

Finish Cards

View color swatches for items listed within this document.

Paints

Plastics/Poly

Wood/Veneer

Laminates

Molded Edges

Edge Styles

Hard Plastics

Glass



Stack/Nesting

Apply® Chairs

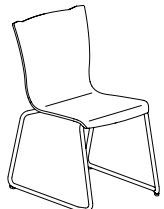
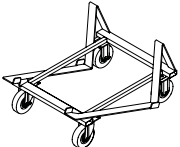
| MODEL | Features | MODEL NUMBER | | | | | | |
|---|----------------------|--------------|--------------------------|--------------------------|--------------------------|--------------------------|--------------------------|--------------------------|
| | | Basic Model | Frame Color | Shell Color | Fire Code | Upholstery Color | Glide (4-Leg) | Glide (Sled Base) |
|  <p>Four-Leg Armless Chair</p> <ul style="list-style-type: none"> • Wood laminate shell • Woodgrain and solid laminate options • Tested to 300 pounds and BIFMA standards | Laminate Shell | ALNAP | <input type="checkbox"/> | <input type="checkbox"/> | | | <input type="checkbox"/> | |
| | Upholstered Seat Pad | ALNAU | <input type="checkbox"/> | <input type="checkbox"/> | <input type="checkbox"/> | <input type="checkbox"/> | <input type="checkbox"/> | |
| ALP ALU | | | | | | | | |
|  <p>Sled Base Armless Chair</p> <ul style="list-style-type: none"> • Wood laminate shell • Woodgrain and solid laminate options • Tested to 300 pounds and BIFMA standards | Laminate Shell | ASNAP | <input type="checkbox"/> | <input type="checkbox"/> | | | | <input type="checkbox"/> |
| | Upholstered Seat Pad | ASNAU | <input type="checkbox"/> | <input type="checkbox"/> | <input type="checkbox"/> | <input type="checkbox"/> | | <input type="checkbox"/> |
| ASP ASU | | | | | | | | |
|  <p>Transport Dolly</p> <ul style="list-style-type: none"> • Easy maneuverability with 5" casters; two fixed, two swivel • Black powder-coated finish • For 4-leg or sled-base chairs | | ACD.BL | | | | | | |
| | HRDPT | | | | | | | |

A **B** **C** **D** **E** **F** **G**

HOW TO ORDER

Indicate the following information on order form:

1. Quantity of each item.
2. Model number, including options. See "How To Build a Model Number".
3. Any special service required.

Note: • The indicates that a choice is required.

- The absence of the indicates that no choice is required.
- Alpha-numeric characters in place of indicate that no other alternatives are available.

HOW TO BUILD A MODEL NUMBER

- A** Select basic model.
- B** Select frame color.
Refer to the **Product Color Options** page in this price list.
- C** Select laminate shell color.
Refer to the **Product Color Options** page in this price list.
- D** Select fire code.
NFR - Compliance to TB 117-2013
FR - Compliance to TB 133
See Upholstery Information for TB133 upcharge.
- E** Select upholstery grade/color.
Refer to ki.com/fabrics
- F** Select 4-leg base glide option.
N - Nylon glides
S - Steel glides

G Select sled base glide option.

- GNG** - No glides
- GNM** - Non-marring glides
- GNS** - Non-skid glides; add \$28
- GBL** - Plastic glides
- GSS** - Stainless steel glide; add \$28



| Approx. Packaged Weight | Delivered Pricing Unupholstered | Delivered Pricing Fabric Grade 1 & C.O.M. | Delivered Pricing Fabric Grade 2 | Delivered Pricing Fabric Grade 3 | Delivered Pricing C.O.V. | Delivered Pricing Vinyl Group 2V | Delivered Pricing Pallas Fabric Group P0 | Delivered Pricing Pallas Fabric Group P1 | Delivered Pricing Pallas Fabric Group P2 | Delivered Pricing Pallas Fabric Group P3 | Delivered Pricing Pallas Fabric Group P4 |
|-------------------------|---------------------------------|---|----------------------------------|----------------------------------|--------------------------|----------------------------------|--|--|--|--|--|
| 20.0# | \$ 382 | | | | | | | | | | |
| 20.0# | N/A | 520 | 524 | 541 | 520 | 541 | 543 | 560 | 614 | 634 | 664 |
| 20.0# | \$ 394 | | | | | | | | | | |
| 20.0# | N/A | 530 | 535 | 551 | 530 | 551 | 554 | 571 | 624 | 645 | 675 |
| 0.0# | \$ 439 | | | | | | | | | | |

OPTIONS

California TB133 Fire Safety Code

For California Technical Bulletin 133 compliant models, add the following upcharge:

Model=Upholstered Seat
Added List Price=\$45

SPECIAL SERVICES

Special Carton Marking

With specially marked information N/C



Shipping

Ships **assembled, FOB Green Bay, WI 54302, freight prepaid.** Freight class 125.

Specifications and prices are subject to change without prior notice.

Stack/Nesting

Apply® Cafe Stools

| | MODEL | Features | MODEL NUMBER | | | | | | |
|---|---|----------------------|--------------|--------------------------|--------------------------|--------------------------|--------------------------|--------------------------|--------------------------|
| | | | Basic Model | Seat Height | Frame Color | Shell Color | Fire Code | Upholstery Color | Glide |
|  <p>24" Shown</p> <p>ALHSP ALHSU</p> | Four-Leg High Back Armless Cafe Stool • Wood laminate shell • Woodgrain and solid laminate options • Two seat heights (24" & 30") • Tested to 300 pounds and BIFMA standards | Laminate Shell | ALHSNAP | <input type="checkbox"/> | <input type="checkbox"/> | <input type="checkbox"/> | | | <input type="checkbox"/> |
| | | Upholstered Seat Pad | ALHSNAU | <input type="checkbox"/> | <input type="checkbox"/> | <input type="checkbox"/> | <input type="checkbox"/> | <input type="checkbox"/> | <input type="checkbox"/> |
|  <p>24" Shown</p> <p>ALLSP ALLSU</p> | Four-Leg Low Back Armless Cafe Stool • Wood laminate shell • Woodgrain and solid laminate options • Two seat heights (24" & 30") • Tested to 300 pounds and BIFMA standards | Laminate Shell | ALLSNAP | <input type="checkbox"/> | <input type="checkbox"/> | <input type="checkbox"/> | | | <input type="checkbox"/> |
| | | Upholstered Seat Pad | ALLSNAU | <input type="checkbox"/> | <input type="checkbox"/> | <input type="checkbox"/> | <input type="checkbox"/> | <input type="checkbox"/> | <input type="checkbox"/> |
| | | | A | B | C | D | E | F | G |

HOW TO ORDER

Indicate the following information on order form:

- Quantity of each item.
- Model number, including options. See "How To Build a Model Number".
- Any special service required.

Note: • The indicates that a choice is required.

- The absence of the indicates that no choice is required.
- Alpha-numeric characters in place of indicate that no other alternatives are available.

HOW TO BUILD A MODEL NUMBER

- A** Select basic model.
- B** Select seat height.
 24 - 24" Seat Height
 30 - 30" Seat Height
- C** Select frame color.
 Refer to the **Product Color Options** page in this price list.
- D** Select laminate shell color.
 Refer to the **Product Color Options** page in this price list.
- E** Select fire code.
 NFR - Compliance to TB 117-2013
 FR - Compliance to TB 133
 See Upholstery Information for TB133 upcharge.
- F** Select upholstery grade/color.
 Refer to ki.com/fabrics

- G** Select glide option.
 N - Nylon glides
 S - Steel glides



| Approx. Packaged Weight | Delivered Pricing Unupholstered | Delivered Pricing Fabric Grade 1 & C.O.M. | Delivered Pricing Fabric Grade 2 | Delivered Pricing Fabric Grade 3 | Delivered Pricing C.O.V. | Delivered Pricing Vinyl Group 2V | Delivered Pricing Pallas Fabric Group P0 | Delivered Pricing Pallas Fabric Group P1 | Delivered Pricing Pallas Fabric Group P2 | Delivered Pricing Pallas Fabric Group P3 | Delivered Pricing Pallas Fabric Group P4 |
|-------------------------|---------------------------------|---|----------------------------------|----------------------------------|--------------------------|----------------------------------|--|--|--|--|--|
| 32.0# | \$ 568 | | | | | | | | | | |
| 32.0# | N/A | 708 | 713 | 735 | 708 | 735 | 751 | 769 | 802 | 823 | 851 |
| 31.0# | \$ 557 | | | | | | | | | | |
| 31.0# | N/A | 697 | 702 | 725 | 697 | 725 | 739 | 757 | 790 | 810 | 839 |

OPTIONS

California TB133 Fire Safety Code

For California Technical Bulletin 133 compliant models, add the following upcharge:

Model=Upholstered Seat
Added List Price=\$45

SPECIAL SERVICES

Special Carton Marking

With specially marked information N/C

Shipping

Ships **assembled, FOB Green Bay, WI 54302, freight prepaid.** Freight class 125.

Specifications and prices are subject to change without prior notice.

Stack/Nesting

Grazie® General Information



Four-Leg Armless Chair
(GLNAU)



Four-Leg Cantilever
Arm Chair
(GLCAP)



Four-Leg Flip-up Tablet
Arm Chair
(GLTAURH)



Four-Leg Flip-up Oversize
Tablet Arm Chair



Four-Leg Flip-and-Store
(G2) Tablet Arm Chair

| Features | | | | | |
|--|---|---|----------|----------|----------|
| Stackable | • | • | | | |
| Poly, upholstered seat, or upholstered seat/back | • | • | • | • | • |
| Ergonomic articulation (Perfect Pivot) | • | • | • | • | • |
| General Dimensions | | | | | |
| Seat width | 18-1/2" | 18-1/2" | 18-1/2" | 18-1/2" | 18-1/2" |
| Seat depth | 18-5/16" | 18-5/16" | 18-5/16" | 18-5/16" | 18-5/16" |
| Seat height (upholstered add 1") | 17-3/4" | 17-3/4" | 17-3/4" | 17-3/4" | 17-3/4" |
| Tablet to chair back clearance | | | 14-1/2" | 14-1/2" | 14-1/2" |
| Overall Dimensions | | | | | |
| Width | 22-3/16" | 25-7/8" | 23-1/2" | 23-1/2" | 23-1/2" |
| Depth | 21-5/16" | 21-5/16" | 27-3/8" | 31" | 26-3/4" |
| Height | 32-5/8" | 32-5/8" | 32-5/8" | 32-5/8" | 32-5/8" |
| Top of arm to floor | | 26-1/4" | 26-3/4" | 26-3/4" | 26-3/4" |
| Stacking on Dolly | | | | | |
| Overall width | 25" | 25-7/8" | | | |
| Overall depth | 36" | 36" | | | |
| Quantity/height | 12 Poly Chairs/60" High (6 Uph Chairs) | 12 Poly Chairs/60" High (6 Uph Chairs) | | | |
| Stacking on Floor | | | | | |
| Width | 22-3/16" | 25-7/8" | | | |
| Depth | 28" | 28" | | | |
| Quantity/height | 5 Chairs/43" High | 5 Chairs/43" High | | | |

SPECIFICATIONS

4-Leg Frame

Legs are 7/8" o.d. x 13-gauge tubular steel. A double ring of 7/16" diameter steel wire forms the cross member. The fixed backrest mechanism structure is formed of 1/2" diameter steel wire. All joints are welded.

Sled Frame

Frames are 3/4" o.d. x 13-gauge tubular steel. A double ring of 7/16" diameter steel wire forms the cross member. The fixed backrest mechanism structure is formed of 1/2" diameter steel wire. All joints are welded.

Seat and Shroud

Injection molded polypropylene.

Frame Finishes

Baked-on electrostatically-applied 30° gloss epoxy powder coating or bright nickel-chrome plating.

Glides

The bottom ends of the leg tubes are formed to be vertical where they meet the floor. The leg tubes are capped with polypropylene end caps matching the leg color, (except chrome or hammertone, which use black caps). Three optional glide types are available for leg chairs: swivel poly/nylon, swivel steel and swivel felt glides. The swivel function allows the bottom of the glide to correctly match uneven floor conditions, resulting in less wear. Poly/nylon and felt glides are interchangeable and have easy-on/easy-off replaceable glide caps, which makes field replacement easy and efficient. Swivel poly glides are available in Stone color only. Optional glides for the sled base are co-extruded to provide a softer (non-skid surface to protect the floor, but do not glide. Sled base chairs are also available with black nylon (plastic) glides, stainless steel glides, or non-marring (clear nylon) glides.

Casters

4-leg chairs may be ordered with casters instead of glides. Casters are double-wheel,

high-impact thermoplastic available with hard or soft wheel surface, in black only.

Arms

Optional cantilever arms are available. When equipped with arms, the support structure is a continuation of the rear leg finished to match the frame color. The armrests are injection-molded, glass-reinforced nylon matching the frame finish (except for chrome, hammertone, and metallic finishes which will match poly color. Diamond translucent poly will have light tone armrests; Pewter translucent will have flannel armrests; Bronze translucent will have chocolate armrests). The steel frame tube is inserted into a socket molded into the armrest and secured with a screw.

Flip-up Tablet Arm

Tablet support loop is a continuation of the rear leg and may be ordered on the right or left side. A formed steel hinge is welded to the top of the support structure and secured with screws to the underside of the writing surface. Writing surface for standard tablet is

9-1/2" x 20-3/4" x 12-1/2" and oversize tablet is 15-1/2" x 22-1/2" x 14". Plywood core of 5/8" thick, 11-ply hardwood surfaced with .030" high-pressure laminate top and plain backer undersurface. Tablet flips up for easy access. Edges are lacquered and sealed.

Flip-and-Store (G2) Tablet Arm

The pivot mechanism consists of two pivot cams, two steel hinge barrels, a pivot shaft, and a hinged steel support plate which fastens to the tablet board. Available in right - or left-hand models. The working surface is 13-3/4" x 18-1/8".

Backrest Articulation Mechanism

A pair of outer backrest supports formed from 1" diameter tubular steel are inserted into sockets molded into the backrest and secured with screws. The backrest assembly moves over molded thermoplastic slide bushings and is supported by steel coil springs. This mechanism allows the backrest to move through 15 degrees of movement, about an axis of rotation that is through the hips of the occupant.



Sled Base Armless Chair (GSNAP)



Sled Base Cantilever Arm Chair (GSCAU)



Sled Base Flip-up Tablet Arm Chair (GSTAPRH)



Sled Base Flip-up Oversize Tablet Arm Chair



Sled Base Flip-and-Store (G2) Tablet Arm Chair



Transport Dolly (GCD.BL)

| Features | | | | | | |
|--|--|--|----------|----------|----------|---------|
| Stackable | • | • | | | | |
| Poly, upholstered seat, or upholstered seat/back | • | • | • | • | • | |
| Ergonomic articulation (Perfect Pivot) | • | • | • | • | • | |
| General Dimensions | | | | | | |
| Seat width | 18-1/2" | 18-1/2" | 18-1/2" | 18-1/2" | 18-1/2" | |
| Seat depth | 18-5/16" | 18-5/16" | 18-5/16" | 18-5/16" | 18-5/16" | |
| Seat height (upholstered add 1") | 17-3/4" | 17-3/4" | 17-3/4" | 17-3/4" | 17-3/4" | |
| Tablet to chair back clearance | | | 14-1/2" | 14-1/2" | 14-1/2" | |
| Overall Dimensions | | | | | | |
| Width | 22" | 25-7/8" | 23-1/2" | 23-1/2" | 23-1/2" | 25" |
| Depth | 21-1/4" | 21-1/4" | 27-3/8" | 31" | 26-3/4" | 29" |
| Height | 32-5/8" | 32-5/8" | 32-5/8" | 32-5/8" | 32-5/8" | 15-3/4" |
| Arms to floor | | 26-1/4" | | | | |
| Stacking on Dolly | | | | | | |
| Overall width | 25" | 25-7/8" | | | | |
| Overall depth | 36" | 36" | | | | |
| Quantity/height | 12 Poly Chairs/60" High (6 Uph Chairs) | 12 Poly Chairs/60" High (6 Uph Chairs) | | | | |
| Stacking on Floor | | | | | | |
| Width | 22-3/16" | 25-7/8" | | | | |
| Depth | 28" | 28" | | | | |
| Quantity/height | 5 Chairs/43" High | 5 Chairs/43" High | | | | |

Optional Upholstered Seat and Back

Urethane foam is attached to an injection-molded polypropylene liner board, then upholstered using a draw-string process. Seat foam is molded nominal 1" thickness and back foam is nominal 1/2" thickness. The fasteners that attach the back pad are color-matched to the polypropylene.

Stacking Vinyl, Polyurethane, and Imitation Leather Upholstered Chairs

It is recommended that chairs to be stacked be covered in material other than vinyl, polyurethane, or imitation leather as an impression in the seat may result. KI does not warrant the effects of stacking on stock or C.O.M. vinyl, polyurethane, or imitation leather upholstery.

INFORMATION

C.O.M. Testing and Production Requirements

Not all materials are suitable for upholstering this product. A 1 yd. x 54" sample must be submitted and approved prior to acceptance of an order. If the fabric is directional in pattern or weave, the direction must be indicated on the submitted sample, and additional yardage may be requested. Test samples must be sent to:

KI
Attn: C.O.M. Specialist
1687 Westminster Drive - Gate 3
Green Bay, WI 54302

Fabric Disclaimer

Fabric will be applied as swatched by the fabric manufacturer. Fabric that is required to be applied differently than is swatched will need a Special Cost Request written specifying the direction the fabric is to be applied. The posted standard lead time will apply to the Special Cost Request.

Design

Designed by Giancarlo Piretti and manufactured in the USA by Krueger International, Inc. under license from Pro-Cord S.p.A

INFORMATION

Warranty

Refer to KI Terms & Conditions document or visit www.ki.com

Stack/Nesting

Grazie® General Information



Four-Leg Armless Chair with Casters (GLNAUC)



Four-Leg Cantilever Arm Chair with Casters (GLCAUC)



Four-Leg Flip-up Tablet Arm Chair with Casters (GLTAPCRH)



Four-Leg Flip-up Oversize Tablet Arm Chair with Casters



Four-Leg Flip-and-Store (G2) Tablet Arm Chair with Casters

| Features | | | | | |
|--|-------------------|-------------------|----------|----------|----------|
| Stackable | • | • | | | |
| Poly, upholstered seat, or upholstered seat/back | • | • | • | • | • |
| Ergonomic articulation (Perfect Pivot) | • | • | • | • | • |
| General Dimensions | | | | | |
| Seat width | 18-1/2" | 18-1/2" | 18-1/2" | 18-1/2" | 18-1/2" |
| Seat depth | 18-5/16" | 18-5/16" | 18-5/16" | 18-5/16" | 18-5/16" |
| Seat height (upholstered add 1") | 17-3/4" | 17-3/4" | 17-3/4" | 17-3/4" | 17-3/4" |
| Tablet to chair back clearance | | | 14-1/2" | 14-1/2" | 14-1/2" |
| Overall Dimensions | | | | | |
| Width | 23" | 25-7/8" | 24" | 24" | 24" |
| Depth | 21-5/16" | 21-5/16" | 27-3/8" | 31" | 26-3/4" |
| Height | 32-5/8" | 32-5/8" | 32-5/8" | 32-5/8" | 32-5/8" |
| Arms to floor | | 26-1/4" | | | |
| Stacking on Floor | | | | | |
| Width | 23" | 25-7/8" | | | |
| Depth | 28" | 28" | | | |
| Quantity/height | 5 Chairs/43" High | 5 Chairs/43" High | | | |

SPECIFICATIONS

4-Leg Frame

Legs are 7/8" o.d. x 13-gauge tubular steel. A double ring of 7/16" diameter steel wire forms the cross member. The fixed backrest mechanism structure is formed of 1/2" diameter steel wire. All joints are welded.

Sled Frame

Frames are 3/4" o.d. x 13-gauge tubular steel. A double ring of 7/16" diameter steel wire forms the cross member. The fixed backrest mechanism structure is formed of 1/2" diameter steel wire. All joints are welded.

Frame Finishes

Baked-on electrostatically-applied 30° gloss epoxy powder coating or bright nickel-chrome plating.

Glides

The bottom ends of the leg tubes are formed to be vertical where they meet the floor. The

leg tubes are capped with polypropylene end caps matching the leg color (except chrome, hammertone, and metallic finishes which use black caps). Optional glides for the sled base are co-extruded to provide a softer, non-skid surface to protect the floor, but do not glide. Sled base chairs are also available with black nylon (plastic), stainless steel, or non-marring (clear nylon) glides.

Casters

4-leg chairs may be ordered with casters instead of glides. Casters are double-wheel, high-impact thermoplastic available with hard or soft wheel surface, in black only.

Seat and Shroud

Injection molded polypropylene.

Arms

Optional cantilever arms are available. When equipped with arms, the support structure is a continuation of the rear leg finished to match the frame color. The armrests are injection-molded, glass-reinforced nylon

matching the frame finish (except for chrome, hammertone, and metallic finishes which will match poly color. Diamond translucent poly will have light tone armrests; Pewter translucent will have flannel armrests; Bronze translucent will have chocolate armrests). The steel frame tube is inserted into a socket molded into the armrest and secured with a screw.

Flip-up Tablet Arm

Tablet support loop is a continuation of the rear leg and may be ordered on the right or left side. A formed steel hinge is welded to the top of the support structure and secured with screws to the underside of the writing surface. Writing surface for standard tablet is 9-1/2" x 20-3/4" x 12-1/2" and oversize tablet is 15-1/2" x 22-1/2" x 14". Plywood core of 5/8" thick, 11-ply hardwood surfaced with .030" high-pressure laminate top and plain backer undersurface. Tablet flips up for easy access. Edges are lacquered and sealed.

Flip-and-Store (G2) Tablet Arm

The pivot mechanism consists of two pivot cams, two steel hinge barrels, a pivot shaft, and a hinged steel support plate which fastens to the tablet board. Available in right - or left-hand models. The working surface is 13-3/4" x 18-1/8".

Backrest Articulation Mechanism

A pair of outer backrest supports formed from 1" diameter tubular steel are inserted into sockets molded into the backrest and secured with screws. The backrest assembly moves over molded thermoplastic slide bushings and is supported by steel coil springs. This mechanism allows the backrest to move through 15 degrees of movement, about an axis of rotation that is through the hips of the occupant.

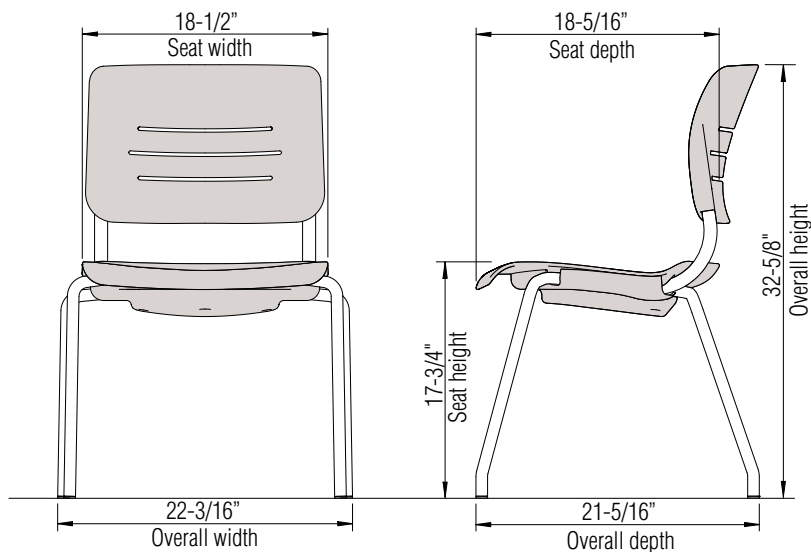

Grazie Armless Four Leg Chair

Optional Upholstered Seat and Back

Urethane foam is attached to an injection-molded polypropylene liner board, then upholstered using a draw-string process. Seat foam is molded nominal 1" thickness and back foam is nominal 1/2" thickness. The fasteners that attach the back pad are color-matched to the polypropylene.

Stacking Vinyl, Polyurethane, and Imitation Leather Upholstered Chairs

It is recommended that chairs to be stacked be covered in material other than vinyl, polyurethane, or imitation leather as an impression in the seat may result. KI does not warrant the effects of stacking on stock or C.O.M. vinyl, polyurethane, or imitation leather upholstery.

INFORMATION

C.O.M. Testing and Production Requirements

Not all materials are suitable for upholstering this product. A 1 yd. x 54" sample must be submitted and approved prior to acceptance of an order. If the fabric is directional in pattern or weave, the direction must be indicated on the submitted sample, and additional yardage may be requested. Test samples must be sent to:

KI
 Attn: C.O.M. Specialist
 1687 Westminster Drive - Gate 3
 Green Bay, WI 54302

Fabric Disclaimer

Fabric will be applied as swatched by the fabric manufacturer. Fabric that is required to be applied differently than is swatched will need a Special Cost Request written specifying the direction the fabric is to be applied. The posted standard lead time will apply to the Special Cost Request.

Design

Designed by Giancarlo Piretti and manufactured in the USA by Krueger International, Inc. under license from Pro-Cord S.p.A

INFORMATION

Warranty

Refer to KI Terms & Conditions document or visit www.ki.com

Stack/Nesting

Grazie® General Information



**Four-Leg Armless Cafe Stool -
24" or 30" Seat Height
(GLSNAP)**

**Four-Leg Cantilever Arm
Cafe Stool - 24" or 30" Seat Height**

| Features | | |
|--|--------------------------|--------------------------|
| Stackable | • | • |
| Poly, upholstered seat, or upholstered seat/back | • | • |
| Ergonomic articulation (Perfect Pivot) | • | • |
| General Dimensions | | |
| Seat width | 18-1/2" | 18-1/2" |
| Seat depth | 18-5/16" | 18-5/16" |
| Seat height (upholstered add 1") | 23-3/4" or 29-3/4" | 23-3/4" or 29-3/4" |
| Overall Dimensions | | |
| Width | 22-3/16" | 25-7/8" |
| Depth | 21-5/16" | 21-5/16" |
| Height | 38-5/8" or 44-5/8" | 38-5/8" or 44-5/8" |
| Arms to floor | | 32-1/4" or 38-1/4" |
| Stacking on Floor | | |
| Width | 22-3/16" | 25-7/8" |
| Depth | 28" | 28" |
| Quantity/height | 4 Chairs/48" or 54" High | 4 Chairs/48" or 54" High |

SPECIFICATIONS

4-Leg Frame

Legs are 7/8" o.d. x 13 -gauge tubular steel. A double ring of 7/16" diameter steel wire forms the cross member. The fixed backrest mechanism structure is formed of 1/2" diameter steel wire. A 3-sided foot ring is made of a pair of 7/16" diameter steel wires. All joints are welded.

Frame Finishes

Baked-on electrostatically-applied 30° gloss epoxy powder coating or bright nickel-chrome plating.

Glides

The bottom ends of the leg tubes are formed to be vertical where they meet the floor. The leg tubes are capped with polypropylene end caps matching the leg color (except chrome, hammertone, and metallic finishes which use black caps).

Seat and Shroud

Injection molded polypropylene.

Backrest Articulation Mechanism

A pair of outer backrest supports formed from 1" diameter tubular steel are inserted into sockets molded into the backrest and secured with screws. The backrest assembly moves over molded thermoplastic slide bushings and is supported by steel coil springs. This mechanism allows the backrest to move through 15 degrees of movement, about an axis of rotation that is through the hips of the occupant.

Optional Upholstered Seat and Back

Urethane foam is attached to an injection-molded polypropylene liner board, then upholstered using a draw-string process. Seat foam is molded nominal 1" thickness and back foam is nominal 1/2" thickness. The fasteners that attach the back pad are color-matched to the polypropylene.

Arms

Optional cantilever arms are available. When equipped with arms, the support structure is a continuation of the rear leg finished to match the frame color. The armrests are injection-molded, glass-reinforced nylon matching the frame finish (except for chrome, hammertone, and metallic finishes which will match poly color. Diamond translucent poly will have light tone armrests; Pewter translucent will have flannel armrests; Bronze translucent will have chocolate armrests). The steel frame tube is inserted into a socket molded into the armrest and secured with a screw.

Stacking Vinyl, Polyurethane, and Imitation Leather Upholstered Stools

It is recommended that stools to be stacked be covered in material other than vinyl, polyurethane, or imitation leather as an impression in the seat may result. KI does not warrant the effects of stacking on stock or C.O.M. vinyl, polyurethane, or imitation leather upholstery.

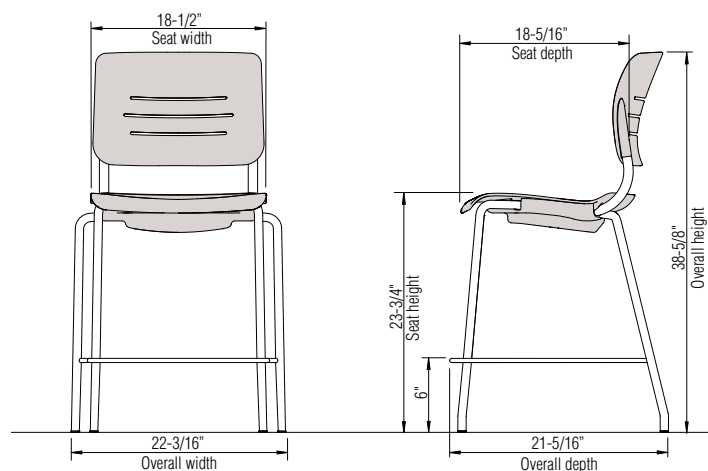
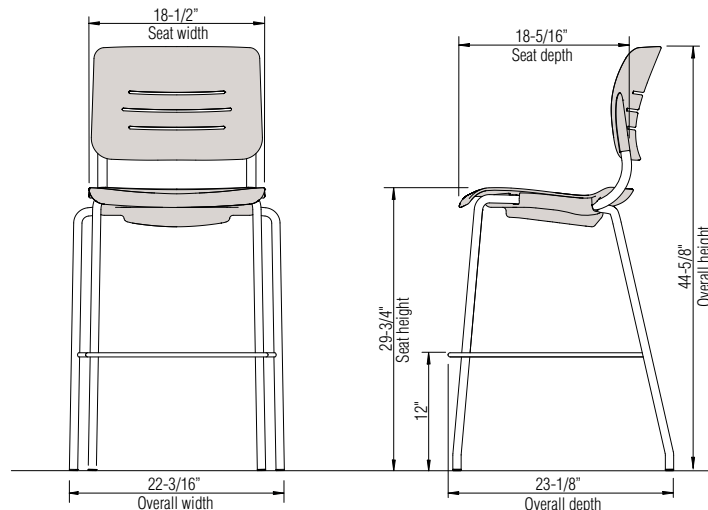
Grazie 24" Cafe Stool

Grazie 30" Cafe Stool
INFORMATION
C.O.M. Testing and Production Requirements

Not all materials are suitable for upholstering this product. A 1 yd. x 54" sample must be submitted and approved prior to acceptance of an order. If the fabric is directional in pattern or weave, the direction must be indicated on the submitted sample, and additional yardage may be requested.

Test samples must be sent to:

KI
 Attn: C.O.M. Specialist
 1687 Westminster Drive - Gate 3
 Green Bay, WI 54302

Fabric Disclaimer

Fabric will be applied as swatched by the fabric manufacturer. Fabric that is required to be applied differently than is swatched will need a Special Cost Request written specifying the direction the fabric is to be applied. The posted standard lead time will apply to the Special Cost Request.

Design

Designed by Giancarlo Piretti and manufactured in the USA by Krueger International, Inc. under license from Pro-Cord S.p.A

INFORMATION
Warranty

Refer to KI Terms & Conditions document or visit www.ki.com

Stack/Nesting

Grazie® Color Options

Frame Color

| | |
|---------------------------|----|
| Antique Vein | AV |
| Black | BL |
| Blue Grey | GR |
| Bronze Metallic | ZM |
| Cayenne | CY |
| Champagne Metallic | CM |
| Chocolate | CT |
| Chrome | CH |
| Cool Grey | CG |
| Cottonwood | CO |
| Espresso Metallic | EX |
| Flannel | FN |
| Grass Green | GN |
| Light Tone | LG |
| Mardi Gras | MG |
| Misty Brown | MY |
| Nemo | NE |
| Nickel Vein | NK |
| Nordic | ND |
| Poppy Red | PR |
| Purple Haze | PH |
| Rubber Ducky | RK |
| Sand | SA |
| Sky Blue | SK |
| Splash | SH |
| Starlight Silver Metallic | SX |
| Surf's Up | SP |
| Ultra Blue | UB |
| Warm Grey | WG |
| Wet Sand | WS |
| Zesty Lime | ZL |

Armcaps and glides match the frame color with the following exceptions:

-When frame color is chrome, metallic, or hammertone, the armcaps and glides will match poly color.

-When frame color is chrome, metallic, or hammertone, and the poly color is translucent diamond, the armcaps will be light tone.

-When frame color is chrome, metallic, or hammertone, and the poly color is translucent pewter, the armcaps will be flannel.

-When frame color is chrome, metallic, or hammertone, and the poly color is translucent bronze, the armcaps will be chocolate.

Casters for four-leg chairs are always black.

Seat and Back Color - Polypropylene Non Flame-Retardant

| | |
|--------------|-----|
| Black | PBL |
| Blue Grey | PGR |
| Cayenne | PCY |
| Chocolate | PCT |
| Cool Grey | PCG |
| Cottonwood | PCO |
| Flannel | PFN |
| Grass Green | PGN |
| Light Tone | PLG |
| Mardi Gras | PMG |
| Misty Brown | PMY |
| Nemo | PNE |
| Nordic | PND |
| Poppy Red | PPR |
| Purple Haze | PPH |
| Rubber Ducky | PRK |
| Sand | PSA |
| Sky Blue | PSK |
| Splash | PSH |
| Surf's Up | PSP |
| Ultra Blue | PUB |
| Warm Grey | PWG |
| Wet Sand | PWS |
| Zesty Lime | PZL |

Seat and Back Color - Polypropylene Flame-Retardant

| | |
|-------|-----|
| Black | PBL |
|-------|-----|

The above seating product can be manufactured using the appropriate flame-retardant materials for compliance to California Technical Bulletin 133.

TRANSLUCENT colors are available on the upholstered seat models only.

Tablet Arm Color - Laminate

| | |
|--------------------|-----|
| Biltmore Cherry | LBT |
| Black | LBK |
| Brighton Walnut | LBW |
| Canyon Zephyr | LCA |
| Castle Oak | LCO |
| Casual Linen | LCU |
| Cherry Storm | LCX |
| Classic Linen | LCI |
| Cloud Zephyr | LCL |
| Cocobala | LCC |
| Coffee Bean | LCB |
| Crisp Linen | LRI |
| Desert Zephyr | LDZ |
| Dove Grey | LDG |
| Fired Steel | LIL |
| Flax Linen | LXF |
| Florence Walnut | LFC |
| Forged Steel | LOL |
| Frosty White | LFW |
| Graphite Nebula | LGN |
| Grey | LGE |
| High Rise | LHE |
| Hollyberry | LHY |
| Irish Linen | LIH |
| Island | LID |
| Italian Silver Ash | LIT |
| Kensington Maple | LKM |
| Lapis Blue | LLB |
| Markerboard White | LMK |
| Misted Zephyr | LMR |
| Monticello Maple | LMT |
| Nickel Evolv | LNV |
| North Sea | LNA |
| Ocean | LON |
| Orange Grove | LOE |
| Pearl Bisque | LPB |
| Pearl Silver | LPS |
| Pressed Linen | LPR |
| River Cherry | LRY |
| Rugged Linen | LRG |
| Satin Stainless | LSS |
| Shadow Zephyr | LSR |
| Silicon evolv | LSV |
| Sterling Ash | LAZ |
| Tailored Linen | LTL |
| Titanium evolv | LTV |
| White Nebula | LWL |
| White Sand | LWN |
| Windsor Mahogany | LWY |

Finish Cards

View color swatches for items listed within this document.

Paints

Wood/Veneer

Molded Edges

Hard Plastics

Plastics/Poly

Laminates



Edge Styles

Glass



Stack/Nesting

Grazie® Chairs

| | MODEL | Features | MODEL NUMBER | | | | | | | | |
|---|--|--|-------------------------|--------------------------|--------------------------|--------------------------|--------------------------|--------------------------|--------------------------|--------------------------|--------------------------|
| | | | Basic Model | Frame Color | Seat & Back Color | Caster Type | Glide Option | Fire Code | Upholstery Color | | |
|  <p>GLP GLU GLUB</p> | Four-Leg Armless Chair | Polypropylene | GLNAP | <input type="checkbox"/> | <input type="checkbox"/> | <input type="checkbox"/> | <input type="checkbox"/> | <input type="checkbox"/> | <input type="checkbox"/> | <input type="checkbox"/> | |
| | | • Ergonomic articulation (Perfect Pivot) | Upholstered Seat | GLNAU | <input type="checkbox"/> | <input type="checkbox"/> | <input type="checkbox"/> | <input type="checkbox"/> | <input type="checkbox"/> | <input type="checkbox"/> | <input type="checkbox"/> |
| | | • Stacking | Upholstered Seat/Back | GLNAUB | <input type="checkbox"/> | <input type="checkbox"/> | <input type="checkbox"/> | <input type="checkbox"/> | <input type="checkbox"/> | <input type="checkbox"/> | <input type="checkbox"/> |
| | | | | | | | | | | | |
|  <p>GLP GLU GLUB</p> | Four-Leg Armless Chair with Casters | Polypropylene, Casters | GLNAPC | <input type="checkbox"/> | <input type="checkbox"/> | <input type="checkbox"/> | <input type="checkbox"/> | <input type="checkbox"/> | <input type="checkbox"/> | <input type="checkbox"/> | |
| | | • Ergonomic articulation (Perfect Pivot) | Uph. Seat, Casters | GLNAUC | <input type="checkbox"/> | <input type="checkbox"/> | <input type="checkbox"/> | <input type="checkbox"/> | <input type="checkbox"/> | <input type="checkbox"/> | <input type="checkbox"/> |
| | | • Stacking. Caution should be exercised to prevent casters from marring components such as frames, fabric, etc., and to prevent casters from becoming "hung up" underneath the seat of the chair | Uph. Seat/Back, Casters | GLNAUBC | <input type="checkbox"/> | <input type="checkbox"/> | <input type="checkbox"/> | <input type="checkbox"/> | <input type="checkbox"/> | <input type="checkbox"/> | <input type="checkbox"/> |
| | | • Stacking on dollies is NOT recommended | | | | | | | | | |
| | | | | | | | | | | | |
| | | | | | | | | | | | |
| | | | | | | | | | | | |
| | | | | | | | | | | | |
| | | | | | | | | | | | |
| | | | | | | | | | | | |

A **B** **C** **D** **E** **F** **G**

HOW TO ORDER

Indicate the following information on order form:

- Quantity of each item.
- Model number, including options. See "How To Build a Model Number".
- Any special service required.

Note: • The indicates that a choice is required.

- The absence of the indicates that no choice is required.
- Alpha-numeric characters in place of indicate that no other alternatives are available.

HOW TO BUILD A MODEL NUMBER

A Select basic model.

B Select frame color.
Refer to the **Product Color Options** page in this price list.

C Select poly seat and back color.
Refer to the **Product Color Options** page in this price list.

D Select casters.

| | |
|----------|-----------------------------------|
| C | - Carpet casters (black only) |
| S | - Hard floor casters (black only) |

E Select glide option.

| | |
|----------|------------------|
| F | - Felt Glides |
| P | - Plastic glides |
| S | - Steel glides |

F Select fire code.

NFR - Compliance to TB 117-2013

FR - Compliance to TB 133

See Upholstery Information for TB133 upcharge.

G Select upholstery grade/color.
Refer to ki.com/fabrics



| Approx. Packaged Weight | Delivered Pricing Unupholstered | Delivered Pricing Fabric Grade 1 & C.O.M. | Delivered Pricing Fabric Grade 2 | Delivered Pricing Fabric Grade 3 | Delivered Pricing C.O.V. | Delivered Pricing Vinyl Group 2V | Delivered Pricing Pallas Fabric Group P0 | Delivered Pricing Pallas Fabric Group P1 | Delivered Pricing Pallas Fabric Group P2 | Delivered Pricing Pallas Fabric Group P3 | Delivered Pricing Pallas Fabric Group P4 |
|-------------------------|---------------------------------|---|----------------------------------|----------------------------------|--------------------------|----------------------------------|--|--|--|--|--|
| 23.0# | \$ 341 | | | | | | | | | | |
| 26.0# | N/A | 463 | 471 | 487 | 463 | 487 | 495 | 535 | 551 | 571 | 599 |
| 28.0# | N/A | 491 | 500 | 517 | 491 | 517 | 525 | 565 | 581 | 601 | 628 |
| 24.0# | \$ 364 | | | | | | | | | | |
| 27.0# | N/A | 485 | 493 | 510 | 485 | 510 | 518 | 557 | 575 | 594 | 621 |
| 28.0# | N/A | 513 | 522 | 539 | 513 | 539 | 547 | 587 | 603 | 622 | 651 |

UPHOLSTERY INFORMATION

C.O.M. Upholstery

C.O.M. requirement for 10 chairs or less with upholstered seat or upholstered seat and back is 3/4 yard per chair of 54" wide nondirectional fabric. For orders of 11 or more with upholstered seat and back and for complete information on ordering C.O.M. see "Ordering C.O.M., C.O.V. and C.O.L." section.

California TB133 Fire Safety Code

For California Technical Bulletin 133 compliant models, add the following upcharge:

Model=Polypropylene
 Added List Price=\$10

Model=Upholstered Seat
 Added List Price=\$70

Model=Upholstered Seat and Back
 Added List Price=\$100

SPECIAL SERVICES

Special Carton Marking

With specially marked information N/C



Shipping

Ships **assembled, FOB Green Bay, WI 54302, freight prepaid.** Freight class 125.

Specifications and prices are subject to change without prior notice.

Stack/Nesting

Grazie® Chairs

| | MODEL | Features | MODEL NUMBER | | | | | | |
|---|---|-------------------------|--------------|--------------------------|--------------------------|--------------------------|--------------------------|--------------------------|--------------------------|
| | | | Basic Model | Frame Color | Seat & Back Color | Caster Type | Glide Option | Fire Code | Upholstery Color |
|  <p>GLP GLU GLUB</p> | Four-Leg Cantilever Arm Chair • Ergonomic articulation (Perfect Pivot) • Stacking | Polypropylene | GLCAP | <input type="checkbox"/> | <input type="checkbox"/> | | <input type="checkbox"/> | <input type="checkbox"/> | |
| | | Upholstered Seat | GLCAU | <input type="checkbox"/> | <input type="checkbox"/> | | <input type="checkbox"/> | <input type="checkbox"/> | <input type="checkbox"/> |
| | | Upholstered Seat/Back | GLCAUB | <input type="checkbox"/> | <input type="checkbox"/> | | <input type="checkbox"/> | <input type="checkbox"/> | <input type="checkbox"/> |
| | | | | | | | | | |
|  <p>GLP GLU GLUB</p> | Four-Leg Cantilever Arm Chair with Casters • Ergonomic articulation (Perfect Pivot) • Stacking. Caution should be exercised to prevent casters from marring components such as frames, fabric, etc., and to prevent casters from becoming "hung up" underneath the seat of the chair • Stacking on dollies is NOT recommended | Polypropylene, Casters | GLCAPC | <input type="checkbox"/> | <input type="checkbox"/> | <input type="checkbox"/> | | <input type="checkbox"/> | |
| | | Uph. Seat, Casters | GLCAUC | <input type="checkbox"/> | <input type="checkbox"/> | <input type="checkbox"/> | | <input type="checkbox"/> | <input type="checkbox"/> |
| | | Uph. Seat/Back, Casters | GLCAUBC | <input type="checkbox"/> | <input type="checkbox"/> | <input type="checkbox"/> | | <input type="checkbox"/> | <input type="checkbox"/> |
| | | | | | | | | | |
| | | | A | B | C | D | E | F | G |

HOW TO ORDER

Indicate the following information on order form:

- Quantity of each item.
- Model number, including options. See "How To Build a Model Number".
- Any special service required.

Note: • The indicates that a choice is required.

- The absence of the indicates that no choice is required.
- Alpha-numeric characters in place of indicate that no other alternatives are available.

HOW TO BUILD A MODEL NUMBER

- A** Select basic model.
- B** Select frame color.
Refer to the **Product Color Options** page in this price list.
- C** Select poly seat and back color.
Refer to the **Product Color Options** page in this price list.
- D** Select casters.

| | |
|----------|-----------------------------------|
| C | - Carpet casters (black only) |
| S | - Hard floor casters (black only) |
- E** Select glide option.

| | |
|----------|------------------|
| F | - Felt Glides |
| P | - Plastic glides |
| S | - Steel glides |

F Select fire code.

- | | |
|------------|-----------------------------|
| NFR | - Compliance to TB 117-2013 |
| FR | - Compliance to TB 133 |

See Upholstery Information for TB133 upcharge.

G Select upholstery grade/color.
Refer to ki.com/fabrics



| Approx. Packaged Weight | Delivered Pricing Unupholstered | Delivered Pricing Fabric Grade 1 & C.O.M. | Delivered Pricing Fabric Grade 2 | Delivered Pricing Fabric Grade 3 | Delivered Pricing C.O.V. | Delivered Pricing Vinyl Group 2V | Delivered Pricing Pallas Fabric Group P0 | Delivered Pricing Pallas Fabric Group P1 | Delivered Pricing Pallas Fabric Group P2 | Delivered Pricing Pallas Fabric Group P3 | Delivered Pricing Pallas Fabric Group P4 |
|-------------------------|---------------------------------|---|----------------------------------|----------------------------------|--------------------------|----------------------------------|--|--|--|--|--|
| 26.0# | \$ 454 | | | | | | | | | | |
| 29.0# | N/A | 576 | 584 | 599 | 576 | 599 | 610 | 650 | 666 | 685 | 712 |
| 31.0# | N/A | 604 | 614 | 629 | 604 | 629 | 638 | 677 | 694 | 712 | 740 |
| | | | | | | | | | | | |
| | | | | | | | | | | | |
| | | | | | | | | | | | |
| | | | | | | | | | | | |
| | | | | | | | | | | | |
| 27.0# | \$ 477 | | | | | | | | | | |
| 30.0# | N/A | 597 | 606 | 621 | 597 | 621 | 631 | 671 | 686 | 706 | 734 |
| 31.0# | N/A | 625 | 635 | 651 | 625 | 651 | 659 | 700 | 717 | 736 | 764 |

UPHOLSTERY INFORMATION

C.O.M. Upholstery

C.O.M. requirement for 10 chairs or less with upholstered seat or upholstered seat and back is 3/4 yard per chair of 54" wide nondirectional fabric. For orders of 11 or more with upholstered seat and back and for complete information on ordering C.O.M. see "Ordering C.O.M., C.O.V. and C.O.L." section.

California TB133 Fire Safety Code

For California Technical Bulletin 133 compliant models, add the following upcharge:

Model=Polypropylene
Added List Price=\$10

Model=Upholstered Seat
Added List Price=\$70

Model=Upholstered Seat and Back
Added List Price=\$100

SPECIAL SERVICES

Special Carton Marking

With specially marked information N/C



Shipping

Ships **assembled, FOB Green Bay, WI 54302, freight prepaid.** Freight class 125.

Specifications and prices are subject to change without prior notice.

Stack/Nesting

Grazie® Chairs

| | MODEL | Features | MODEL NUMBER | | | | | | |
|--|--|----------------------------|--------------|--------------------------|--------------------------|--------------------------|--------------------------|--------------------------|--------------------------|
| | | | Basic Model | Frame Color | Seat & Back Color | Glide Option | Tablet Arm Color | Fire Code | Uph. Color |
|  | Four-Leg Flip-up Tablet Arm Chair • Ergonomic articulation (Perfect Pivot) • NONSTACKING | Polypropylene, Left Hand | GLTAPLH | <input type="checkbox"/> | <input type="checkbox"/> | <input type="checkbox"/> | <input type="checkbox"/> | <input type="checkbox"/> | |
| | | Polypropylene, Right Hand | GLTAPRH | <input type="checkbox"/> | <input type="checkbox"/> | <input type="checkbox"/> | <input type="checkbox"/> | <input type="checkbox"/> | |
| | | Uph. Seat, Left Hand | GLTAULH | <input type="checkbox"/> | <input type="checkbox"/> | <input type="checkbox"/> | <input type="checkbox"/> | <input type="checkbox"/> | <input type="checkbox"/> |
| | | Uph. Seat, Right Hand | GLTAURH | <input type="checkbox"/> | <input type="checkbox"/> | <input type="checkbox"/> | <input type="checkbox"/> | <input type="checkbox"/> | <input type="checkbox"/> |
| | | Uph. Seat/Back, Left Hand | GLTAUBLH | <input type="checkbox"/> | <input type="checkbox"/> | <input type="checkbox"/> | <input type="checkbox"/> | <input type="checkbox"/> | <input type="checkbox"/> |
| | | Uph. Seat/Back, Right Hand | GLTAUBRH | <input type="checkbox"/> | <input type="checkbox"/> | <input type="checkbox"/> | <input type="checkbox"/> | <input type="checkbox"/> | <input type="checkbox"/> |
| | | | | | | | | | |
| GLP | | | | | | | | | |
| GLU | | | | | | | | | |
| GLUB | | | | | | | | | |
|  | Four-Leg Flip-up Oversize Tablet Arm Chair • Oversized tablet • Ergonomic articulation (Perfect Pivot) • NONSTACKING | Polypropylene, Left Hand | GLOVTAPLH | <input type="checkbox"/> | <input type="checkbox"/> | <input type="checkbox"/> | <input type="checkbox"/> | <input type="checkbox"/> | |
| | | Polypropylene, Right Hand | GLOVTAPRH | <input type="checkbox"/> | <input type="checkbox"/> | <input type="checkbox"/> | <input type="checkbox"/> | <input type="checkbox"/> | |
| | | Uph. Seat, Left Hand | GLOVTAULH | <input type="checkbox"/> | <input type="checkbox"/> | <input type="checkbox"/> | <input type="checkbox"/> | <input type="checkbox"/> | <input type="checkbox"/> |
| | | Uph. Seat, Right Hand | GLOVTAURH | <input type="checkbox"/> | <input type="checkbox"/> | <input type="checkbox"/> | <input type="checkbox"/> | <input type="checkbox"/> | <input type="checkbox"/> |
| | | Uph. Seat/Back, Left Hand | GLOVTAUBLH | <input type="checkbox"/> | <input type="checkbox"/> | <input type="checkbox"/> | <input type="checkbox"/> | <input type="checkbox"/> | <input type="checkbox"/> |
| | | Uph. Seat/Back, Right Hand | GLOVTAUBRH | <input type="checkbox"/> | <input type="checkbox"/> | <input type="checkbox"/> | <input type="checkbox"/> | <input type="checkbox"/> | <input type="checkbox"/> |
| | | | | | | | | | |
| GLP | | | | | | | | | |
| GLU | | | | | | | | | |
| GLUB | | | | | | | | | |
|  | Four-Leg Flip-and-Store (G2) Tablet Arm Chair • Ergonomic articulation (Perfect Pivot) • NONSTACKING | Polypropylene, Left Hand | GLG2APLH | <input type="checkbox"/> | <input type="checkbox"/> | <input type="checkbox"/> | <input type="checkbox"/> | <input type="checkbox"/> | |
| | | Polypropylene, Right Hand | GLG2APRH | <input type="checkbox"/> | <input type="checkbox"/> | <input type="checkbox"/> | <input type="checkbox"/> | <input type="checkbox"/> | |
| | | Uph. Seat, Left Hand | GLG2AULH | <input type="checkbox"/> | <input type="checkbox"/> | <input type="checkbox"/> | <input type="checkbox"/> | <input type="checkbox"/> | <input type="checkbox"/> |
| | | Uph. Seat, Right Hand | GLG2AURH | <input type="checkbox"/> | <input type="checkbox"/> | <input type="checkbox"/> | <input type="checkbox"/> | <input type="checkbox"/> | <input type="checkbox"/> |
| | | Uph. Seat/Back, Left Hand | GLG2AUBLH | <input type="checkbox"/> | <input type="checkbox"/> | <input type="checkbox"/> | <input type="checkbox"/> | <input type="checkbox"/> | <input type="checkbox"/> |
| | | Uph. Seat/Back, Right Hand | GLG2AUBRH | <input type="checkbox"/> | <input type="checkbox"/> | <input type="checkbox"/> | <input type="checkbox"/> | <input type="checkbox"/> | <input type="checkbox"/> |
| | | | | | | | | | |
| GLP | | | | | | | | | |
| GLU | | | | | | | | | |
| GLUB | | | | | | | | | |

A **B** **C** **D** **E** **F** **G**

HOW TO ORDER

Indicate the following information on order form:

- Quantity of each item.
- Model number, including options. See "How To Build a Model Number".
- Any special service required.

Note: • The indicates that a choice is required.

- The absence of the indicates that no choice is required.
- Alpha-numeric characters in place of indicate that no other alternatives are available.

HOW TO BUILD A MODEL NUMBER

A Select basic model.

B Select frame color.
Refer to the **Product Color Options** page in this price list.

C Select poly seat and back color.
Refer to the **Product Color Options** page in this price list.

D Select glide option.
 F - Felt Glides
 P - Plastic glides
 S - Steel glides

E Select tablet arm color.
Refer to the **Product Color Options** page in this price list.

F Select fire code.

NFR - Compliance to TB 117-2013

FR - Compliance to TB 133

See Upholstery Information for TB133 upcharge.

G Select upholstery grade/color.
Refer to ki.com/fabrics



| Approx. Packaged Weight | Delivered Pricing Unupholstered | Delivered Pricing Fabric Grade 1 & C.O.M. | Delivered Pricing Fabric Grade 2 | Delivered Pricing Fabric Grade 3 | Delivered Pricing C.O.V. | Delivered Pricing Vinyl Group 2V | Delivered Pricing Pallas Fabric Group P0 | Delivered Pricing Pallas Fabric Group P1 | Delivered Pricing Pallas Fabric Group P2 | Delivered Pricing Pallas Fabric Group P3 | Delivered Pricing Pallas Fabric Group P4 |
|-------------------------|---------------------------------|---|----------------------------------|----------------------------------|--------------------------|----------------------------------|--|--|--|--|--|
| 29.0# | \$ 557 | | | | | | | | | | |
| 29.0# | 557 | | | | | | | | | | |
| 32.0# | N/A | 678 | 687 | 702 | 678 | 702 | 711 | 751 | 768 | 787 | 814 |
| 32.0# | N/A | 678 | 687 | 702 | 678 | 702 | 711 | 751 | 768 | 787 | 814 |
| 34.0# | N/A | 707 | 716 | 732 | 707 | 732 | 739 | 779 | 798 | 814 | 843 |
| 34.0# | N/A | 707 | 716 | 732 | 707 | 732 | 739 | 779 | 798 | 814 | 843 |
| 31.0# | \$ 615 | | | | | | | | | | |
| 31.0# | 615 | | | | | | | | | | |
| 34.0# | N/A | 735 | 745 | 760 | 735 | 760 | 769 | 808 | 825 | 843 | 873 |
| 34.0# | N/A | 735 | 745 | 760 | 735 | 760 | 769 | 808 | 825 | 843 | 873 |
| 35.0# | N/A | 764 | 773 | 789 | 764 | 789 | 798 | 837 | 853 | 873 | 901 |
| 35.0# | N/A | 764 | 773 | 789 | 764 | 789 | 798 | 837 | 853 | 873 | 901 |
| 30.0# | \$ 589 | | | | | | | | | | |
| 30.0# | 589 | | | | | | | | | | |
| 33.0# | N/A | 710 | 719 | 734 | 710 | 734 | 744 | 783 | 800 | 820 | 848 |
| 33.0# | N/A | 710 | 719 | 734 | 710 | 734 | 744 | 783 | 800 | 820 | 848 |
| 35.0# | N/A | 738 | 748 | 764 | 738 | 764 | 772 | 811 | 828 | 848 | 876 |
| 35.0# | N/A | 738 | 748 | 764 | 738 | 764 | 772 | 811 | 828 | 848 | 876 |

UPHOLSTERY INFORMATION

C.O.M. Upholstery

C.O.M. requirement for 10 chairs or less with upholstered seat or upholstered seat and back is 3/4 yard per chair of 54" wide nondirectional fabric. For orders of 11 or more with upholstered seat and back and for complete information on ordering C.O.M. see "Ordering C.O.M., C.O.V. and C.O.L." section.

California TB133 Fire Safety Code

For California Technical Bulletin 133 compliant models, add the following upcharge:

Model=Polypropylene
 Added List Price=\$10

Model=Upholstered Seat
 Added List Price=\$70

Model=Upholstered Seat and Back
 Added List Price=\$100

SPECIAL SERVICES

Special Carton Marking

With specially marked information N/C



Shipping

Ships **assembled, FOB Green Bay, WI 54302, freight prepaid.** Freight class 125.

Specifications and prices are subject to change without prior notice.

Stack/Nesting

Grazie® Chairs

| MODEL | Features | MODEL NUMBER | | | | | | |
|---|-----------------------------------|--------------|--------------------------|--------------------------|--------------------------|--------------------------|--------------------------|--------------------------|
| | | Basic Model | Frame Color | Seat & Back Color | Caster Type | Tablet Arm Color | Fire Code | Uph. Color |
|  <p>Four-Leg Flip-up Tablet Arm Chair with Casters</p> <ul style="list-style-type: none"> Ergonomic articulation (Perfect Pivot) NONSTACKING | Poly, Left Hand, Casters | GLTAPCLH | <input type="checkbox"/> | <input type="checkbox"/> | <input type="checkbox"/> | <input type="checkbox"/> | <input type="checkbox"/> | |
| | Poly, Right Hand, Casters | GLTAPCRH | <input type="checkbox"/> | <input type="checkbox"/> | <input type="checkbox"/> | <input type="checkbox"/> | <input type="checkbox"/> | |
| | Uph. Seat, Left Hand, Cast. | GLTAUCLH | <input type="checkbox"/> | <input type="checkbox"/> | <input type="checkbox"/> | <input type="checkbox"/> | <input type="checkbox"/> | <input type="checkbox"/> |
| | Uph. Seat, Right Hand, Cast. | GLTAUCRH | <input type="checkbox"/> | <input type="checkbox"/> | <input type="checkbox"/> | <input type="checkbox"/> | <input type="checkbox"/> | <input type="checkbox"/> |
| | Uph. Seat/Back, Left Hand, Cast. | GLTAUBCLH | <input type="checkbox"/> | <input type="checkbox"/> | <input type="checkbox"/> | <input type="checkbox"/> | <input type="checkbox"/> | <input type="checkbox"/> |
| | Uph. Seat/Back, Right Hand, Cast. | GLTAUBCRH | <input type="checkbox"/> | <input type="checkbox"/> | <input type="checkbox"/> | <input type="checkbox"/> | <input type="checkbox"/> | <input type="checkbox"/> |
| | | | | | | | | |
|  <p>Four-Leg Flip-up Oversize Tablet Arm Chair with Casters</p> <ul style="list-style-type: none"> Oversized tablet Ergonomic articulation (Perfect Pivot) NONSTACKING | Poly, Left Hand, Casters | GLOVTAPCLH | <input type="checkbox"/> | <input type="checkbox"/> | <input type="checkbox"/> | <input type="checkbox"/> | <input type="checkbox"/> | |
| | Poly, Right Hand, Casters | GLOVTAPCRH | <input type="checkbox"/> | <input type="checkbox"/> | <input type="checkbox"/> | <input type="checkbox"/> | <input type="checkbox"/> | |
| | Uph. Seat, Left Hand, Cast. | GLOVTAUCLH | <input type="checkbox"/> | <input type="checkbox"/> | <input type="checkbox"/> | <input type="checkbox"/> | <input type="checkbox"/> | <input type="checkbox"/> |
| | Uph. Seat, Right Hand, Cast. | GLOVTAUCRH | <input type="checkbox"/> | <input type="checkbox"/> | <input type="checkbox"/> | <input type="checkbox"/> | <input type="checkbox"/> | <input type="checkbox"/> |
| | Uph. Seat/Back, Left Hand, Cast. | GLOVTAUBCLH | <input type="checkbox"/> | <input type="checkbox"/> | <input type="checkbox"/> | <input type="checkbox"/> | <input type="checkbox"/> | <input type="checkbox"/> |
| | Uph. Seat/Back, Right Hand, Cast. | GLOVTAUBCRH | <input type="checkbox"/> | <input type="checkbox"/> | <input type="checkbox"/> | <input type="checkbox"/> | <input type="checkbox"/> | <input type="checkbox"/> |
| | | | | | | | | |
|  <p>Four-Leg Flip-and-Store (G2) Tablet Arm Chair with Casters</p> <ul style="list-style-type: none"> Ergonomic articulation (Perfect Pivot) NONSTACKING | Poly, Left Hand, Casters | GLG2APCLH | <input type="checkbox"/> | <input type="checkbox"/> | <input type="checkbox"/> | <input type="checkbox"/> | <input type="checkbox"/> | |
| | Poly, Right Hand, Casters | GLG2APCRH | <input type="checkbox"/> | <input type="checkbox"/> | <input type="checkbox"/> | <input type="checkbox"/> | <input type="checkbox"/> | |
| | Uph. Seat, Left Hand, Cast. | GLG2AUCLH | <input type="checkbox"/> | <input type="checkbox"/> | <input type="checkbox"/> | <input type="checkbox"/> | <input type="checkbox"/> | <input type="checkbox"/> |
| | Uph. Seat, Right Hand, Cast. | GLG2AUCRH | <input type="checkbox"/> | <input type="checkbox"/> | <input type="checkbox"/> | <input type="checkbox"/> | <input type="checkbox"/> | <input type="checkbox"/> |
| | Uph. Seat/Back, Left Hand, Cast. | GLG2AUBCLH | <input type="checkbox"/> | <input type="checkbox"/> | <input type="checkbox"/> | <input type="checkbox"/> | <input type="checkbox"/> | <input type="checkbox"/> |
| | Uph. Seat/Back, Right Hand, Cast. | GLG2AUBCRH | <input type="checkbox"/> | <input type="checkbox"/> | <input type="checkbox"/> | <input type="checkbox"/> | <input type="checkbox"/> | <input type="checkbox"/> |
| | | | | | | | | |

A **B** **C** **D** **E** **F** **G**

HOW TO ORDER

Indicate the following information on order form:

- Quantity of each item.
- Model number, including options. See "How To Build a Model Number".
- Any special service required.

Note: • The indicates that a choice is required.

- The absence of the indicates that no choice is required.
- Alpha-numeric characters in place of indicate that no other alternatives are available.

HOW TO BUILD A MODEL NUMBER

- A** Select basic model.
- B** Select frame color.
Refer to the **Product Color Options** page in this price list.
- C** Select poly seat and back color.
Refer to the **Product Color Options** page in this price list.
- D** Select casters.

| | |
|----------|-----------------------------------|
| C | - Carpet casters (black only) |
| S | - Hard floor casters (black only) |
- E** Select tablet arm color.
Refer to the **Product Color Options** page in this price list.

F Select fire code.

NFR - Compliance to TB 117-2013

FR - Compliance to TB 133

See Upholstery Information for TB133 upcharge.

G Select upholstery grade/color.
Refer to ki.com/fabrics



| Approx. Packaged Weight | Delivered Pricing Unupholstered | Delivered Pricing Fabric Grade 1 & C.O.M. | Delivered Pricing Fabric Grade 2 | Delivered Pricing Fabric Grade 3 | Delivered Pricing C.O.V. | Delivered Pricing Vinyl Group 2V | Delivered Pricing Pallas Fabric Group P0 | Delivered Pricing Pallas Fabric Group P1 | Delivered Pricing Pallas Fabric Group P2 | Delivered Pricing Pallas Fabric Group P3 | Delivered Pricing Pallas Fabric Group P4 |
|-------------------------|---------------------------------|---|----------------------------------|----------------------------------|--------------------------|----------------------------------|--|--|--|--|--|
| 30.0# | \$ 579 | | | | | | | | | | |
| 30.0# | 579 | | | | | | | | | | |
| 33.0# | N/A | 700 | 709 | 725 | 700 | 725 | 733 | 773 | 790 | 808 | 837 |
| 33.0# | N/A | 700 | 709 | 725 | 700 | 725 | 733 | 773 | 790 | 808 | 837 |
| 34.0# | N/A | 729 | 737 | 754 | 729 | 754 | 763 | 803 | 820 | 838 | 865 |
| 34.0# | N/A | 729 | 737 | 754 | 729 | 754 | 763 | 803 | 820 | 838 | 865 |
| 31.0# | \$ 636 | | | | | | | | | | |
| 31.0# | 636 | | | | | | | | | | |
| 34.0# | N/A | 757 | 766 | 781 | 757 | 781 | 790 | 830 | 847 | 865 | 893 |
| 34.0# | N/A | 757 | 766 | 781 | 757 | 781 | 790 | 830 | 847 | 865 | 893 |
| 36.0# | N/A | 786 | 796 | 810 | 786 | 810 | 821 | 860 | 876 | 895 | 922 |
| 36.0# | N/A | 786 | 796 | 810 | 786 | 810 | 821 | 860 | 876 | 895 | 922 |
| 31.0# | \$ 612 | | | | | | | | | | |
| 31.0# | 612 | | | | | | | | | | |
| 34.0# | N/A | 732 | 740 | 756 | 732 | 756 | 765 | 805 | 822 | 840 | 869 |
| 34.0# | N/A | 732 | 740 | 756 | 732 | 756 | 765 | 805 | 822 | 840 | 869 |
| 35.0# | N/A | 761 | 770 | 786 | 761 | 786 | 796 | 835 | 847 | 870 | 898 |
| 35.0# | N/A | 761 | 770 | 786 | 761 | 786 | 796 | 835 | 847 | 870 | 898 |

UPHOLSTERY INFORMATION

C.O.M. Upholstery

C.O.M. requirement for 10 chairs or less with upholstered seat or upholstered seat and back is 3/4 yard per chair of 54" wide nondirectional fabric. For orders of 11 or more with upholstered seat and back and for complete information on ordering C.O.M. see "Ordering C.O.M., C.O.V. and C.O.L." section.

California TB133 Fire Safety Code

For California Technical Bulletin 133 compliant models, add the following upcharge:

Model=Polypropylene
 Added List Price=\$10

Model=Upholstered Seat
 Added List Price=\$70

Model=Upholstered Seat and Back
 Added List Price=\$100

SPECIAL SERVICES

Special Carton Marking

With specially marked information N/C



Shipping

Ships **assembled, FOB Green Bay, WI 54302, freight prepaid.** Freight class 125.

Specifications and prices are subject to change without prior notice.

Stack/Nesting

Grazie® Chairs

| | MODEL | Features | MODEL NUMBER | | | | | | Approx. Packaged Weight |
|---|---|-----------------------|--------------|--------------------------|--------------------------|--------------------------|--------------------------|--------------------------|-------------------------|
| | | | Basic Model | Frame Color | Seat & Back Color | Glide Option | Fire Code | Upholstery Color | |
|  <p>GSP GSU GSUB</p> | Sled Base Armless Chair • Ergonomic articulation (Perfect Pivot) • Stacking | Polypropylene | GSNAP | <input type="checkbox"/> | <input type="checkbox"/> | <input type="checkbox"/> | <input type="checkbox"/> | <input type="checkbox"/> | 25.0# |
| | | Upholstered Seat | GNAU | <input type="checkbox"/> | <input type="checkbox"/> | <input type="checkbox"/> | <input type="checkbox"/> | <input type="checkbox"/> | 28.0# |
| | | Upholstered Seat/Back | GNAUB | <input type="checkbox"/> | <input type="checkbox"/> | <input type="checkbox"/> | <input type="checkbox"/> | <input type="checkbox"/> | 30.0# |
| | | | | | | | | | |
|  <p>GSP GSU GSUB</p> | Sled Base Cantilever Arm Chair • Ergonomic articulation (Perfect Pivot) • Stacking | Polypropylene | GSCAP | <input type="checkbox"/> | <input type="checkbox"/> | <input type="checkbox"/> | <input type="checkbox"/> | <input type="checkbox"/> | 27.0# |
| | | Upholstered Seat | GSCAU | <input type="checkbox"/> | <input type="checkbox"/> | <input type="checkbox"/> | <input type="checkbox"/> | <input type="checkbox"/> | 30.0# |
| | | Upholstered Seat/Back | GSCAUB | <input type="checkbox"/> | <input type="checkbox"/> | <input type="checkbox"/> | <input type="checkbox"/> | <input type="checkbox"/> | 32.0# |
| | | | | | | | | | |

A **B** **C** **D** **E** **F**

HOW TO ORDER

Indicate the following information on order form:

- Quantity of each item.
- Model number, including options. See "How To Build a Model Number".
- Any special service required.

Note: • The indicates that a choice is required.

- The absence of the indicates that no choice is required.
- Alpha-numeric characters in place of indicate that no other alternatives are available.

HOW TO BUILD A MODEL NUMBER

- A** Select basic model.
- B** Select frame color.
Refer to the **Product Color Options** page in this price list.
- C** Select poly seat and back color.
Refer to the **Product Color Options** page in this price list.
- D** Select glide option.

| | |
|------------|-------------------------|
| NGL | - No glides |
| GNM | - Non-marring glides |
| GNS | - Non-skid glides |
| GBL | - Black plastic glides |
| GSS | - Stainless steel glide |
- E** Select fire code.

| | |
|------------|-----------------------------|
| NFR | - Compliance to TB 117-2013 |
| FR | - Compliance to TB 133 |

 See Upholstery Information for TB133 upcharge.

F Select upholstery grade/color.
Refer to ki.com/fabrics



| Delivered Pricing Upholstered | Delivered Pricing Fabric Grade 1 & C.O.M. | Delivered Pricing Fabric Grade 2 | Delivered Pricing Fabric Grade 3 | Delivered Pricing C.O.V. | Delivered Pricing Vinyl Group 2V | Delivered Pricing Pallas Fabric Group P0 | Delivered Pricing Pallas Fabric Group P1 | Delivered Pricing Pallas Fabric Group P2 | Delivered Pricing Pallas Fabric Group P3 | Delivered Pricing Pallas Fabric Group P4 | |
|-------------------------------|---|----------------------------------|----------------------------------|--------------------------|----------------------------------|--|--|--|--|--|-----|
| \$ 353 | N/A | 473 | 484 | 497 | 473 | 497 | 506 | 547 | 563 | 582 | 612 |
| N/A | 502 | 512 | 527 | 502 | 527 | 537 | 577 | 593 | 613 | 640 | |
| \$ 466 | N/A | 587 | 596 | 612 | 587 | 612 | 621 | 660 | 677 | 697 | 725 |
| N/A | 616 | 624 | 641 | 616 | 641 | 649 | 688 | 705 | 725 | 752 | |

UPHOLSTERY INFORMATION

C.O.M. Upholstery

C.O.M. requirement for 10 chairs or less with upholstered seat or upholstered seat and back is 3/4 yard per chair of 54" wide nondirectional fabric. For orders of 11 or more with upholstered seat and back and for complete information on ordering C.O.M. see "Ordering C.O.M., C.O.V. and C.O.L." section.

California TB133 Fire Safety Code

For California Technical Bulletin 133 compliant models, add the following upcharge:

Model=Polypropylene
 Added List Price=\$10

Model=Upholstered Seat
 Added List Price=\$70

Model=Upholstered Seat and Back
 Added List Price=\$100

SPECIAL SERVICES

Special Carton Marking

With specially marked information N/C



Shipping

Ships **assembled, FOB Green Bay, WI 54302, freight prepaid.** Freight class 125.

Specifications and prices are subject to change without prior notice.

Stack/Nesting

Grazie® Chairs

| | MODEL | Features | MODEL NUMBER | | | | | | | |
|--|---|----------------------------|--------------|--------------------------|--------------------------|--------------------------|--------------------------|--------------------------|--------------------------|--------------------------|
| | | | Basic Model | Frame Color | Seat & Back Color | Glide Option | Tablet Arm Color | Fire Code | Uph. Color | |
|  | Sled Base Flip-up Tablet Arm Chair • Ergonomic articulation (Perfect Pivot) • NONSTACKING | Polypropylene, Left Hand | GSTAPLH | <input type="checkbox"/> | <input type="checkbox"/> | <input type="checkbox"/> | <input type="checkbox"/> | <input type="checkbox"/> | <input type="checkbox"/> | |
| | | Polypropylene, Right Hand | GSTAPRH | <input type="checkbox"/> | <input type="checkbox"/> | <input type="checkbox"/> | <input type="checkbox"/> | <input type="checkbox"/> | <input type="checkbox"/> | |
| | | Uph. Seat, Left Hand | GSTAULH | <input type="checkbox"/> | <input type="checkbox"/> | <input type="checkbox"/> | <input type="checkbox"/> | <input type="checkbox"/> | <input type="checkbox"/> | <input type="checkbox"/> |
| | | Uph. Seat, Right Hand | GSTAURH | <input type="checkbox"/> | <input type="checkbox"/> | <input type="checkbox"/> | <input type="checkbox"/> | <input type="checkbox"/> | <input type="checkbox"/> | <input type="checkbox"/> |
| | | Uph. Seat/Back, Left Hand | GSTAUBLH | <input type="checkbox"/> | <input type="checkbox"/> | <input type="checkbox"/> | <input type="checkbox"/> | <input type="checkbox"/> | <input type="checkbox"/> | <input type="checkbox"/> |
| | | Uph. Seat/Back, Right Hand | GSTAUBRH | <input type="checkbox"/> | <input type="checkbox"/> | <input type="checkbox"/> | <input type="checkbox"/> | <input type="checkbox"/> | <input type="checkbox"/> | <input type="checkbox"/> |
| | | GSP GSU GSUB | | | | | | | | |
|  | Sled Base Flip-up Oversize Tablet Arm Chair • Oversized tablet • Ergonomic articulation (Perfect Pivot) • NONSTACKING | Polypropylene, Left Hand | GSOVTAPLH | <input type="checkbox"/> | <input type="checkbox"/> | <input type="checkbox"/> | <input type="checkbox"/> | <input type="checkbox"/> | <input type="checkbox"/> | |
| | | Polypropylene, Right Hand | GSOVTAPRH | <input type="checkbox"/> | <input type="checkbox"/> | <input type="checkbox"/> | <input type="checkbox"/> | <input type="checkbox"/> | <input type="checkbox"/> | |
| | | Uph. Seat, Left Hand | GSOVTAULH | <input type="checkbox"/> | <input type="checkbox"/> | <input type="checkbox"/> | <input type="checkbox"/> | <input type="checkbox"/> | <input type="checkbox"/> | <input type="checkbox"/> |
| | | Uph. Seat, Right Hand | GSOVTAURH | <input type="checkbox"/> | <input type="checkbox"/> | <input type="checkbox"/> | <input type="checkbox"/> | <input type="checkbox"/> | <input type="checkbox"/> | <input type="checkbox"/> |
| | | Uph. Seat/Back, Left Hand | GSOVTAUBLH | <input type="checkbox"/> | <input type="checkbox"/> | <input type="checkbox"/> | <input type="checkbox"/> | <input type="checkbox"/> | <input type="checkbox"/> | <input type="checkbox"/> |
| | | Uph. Seat/Back, Right Hand | GSOVTAUBRH | <input type="checkbox"/> | <input type="checkbox"/> | <input type="checkbox"/> | <input type="checkbox"/> | <input type="checkbox"/> | <input type="checkbox"/> | <input type="checkbox"/> |
| | | GSP GSU GSUB | | | | | | | | |
|  | Sled Base Flip-and-Store (G2) Tablet Arm Chair • Ergonomic articulation (Perfect Pivot) • NONSTACKING | Polypropylene, Left Hand | GSG2APLH | <input type="checkbox"/> | <input type="checkbox"/> | <input type="checkbox"/> | <input type="checkbox"/> | <input type="checkbox"/> | <input type="checkbox"/> | |
| | | Polypropylene, Right Hand | GSG2APRH | <input type="checkbox"/> | <input type="checkbox"/> | <input type="checkbox"/> | <input type="checkbox"/> | <input type="checkbox"/> | <input type="checkbox"/> | |
| | | Uph. Seat, Left Hand | GSG2AULH | <input type="checkbox"/> | <input type="checkbox"/> | <input type="checkbox"/> | <input type="checkbox"/> | <input type="checkbox"/> | <input type="checkbox"/> | <input type="checkbox"/> |
| | | Uph. Seat, Right Hand | GSG2AURH | <input type="checkbox"/> | <input type="checkbox"/> | <input type="checkbox"/> | <input type="checkbox"/> | <input type="checkbox"/> | <input type="checkbox"/> | <input type="checkbox"/> |
| | | Uph. Seat/Back, Left Hand | GSG2AUBLH | <input type="checkbox"/> | <input type="checkbox"/> | <input type="checkbox"/> | <input type="checkbox"/> | <input type="checkbox"/> | <input type="checkbox"/> | <input type="checkbox"/> |
| | | Uph. Seat/Back, Right Hand | GSG2AUBRH | <input type="checkbox"/> | <input type="checkbox"/> | <input type="checkbox"/> | <input type="checkbox"/> | <input type="checkbox"/> | <input type="checkbox"/> | <input type="checkbox"/> |
| | | GSP GSU GSUB | | | | | | | | |

A **B** **C** **D** **E** **F** **G**

HOW TO ORDER

Indicate the following information on order form:

- Quantity of each item.
- Model number, including options. See "How To Build a Model Number".
- Any special service required.

Note: • The indicates that a choice is required.

- The absence of the indicates that no choice is required.
- Alpha-numeric characters in place of indicate that no other alternatives are available.

HOW TO BUILD A MODEL NUMBER

A Select basic model.

B Select frame color.
Refer to the **Product Color Options** page in this price list.

C Select poly seat and back color.
Refer to the **Product Color Options** page in this price list.

D Select glide option.

| | |
|------------|-------------------------|
| NGL | - No glides |
| GNM | - Non-marring glides |
| GNS | - Non-skid glides |
| GBL | - Black plastic glides |
| GSS | - Stainless steel glide |

E Select tablet arm color.
Refer to the **Product Color Options** page in this price list.

F Select fire code.

NFR - Compliance to TB 117-2013

FR - Compliance to TB 133

See Upholstery Information for TB133 upcharge.

G Select upholstery grade/color.
Refer to ki.com/fabrics



| Approx. Packaged Weight | Delivered Pricing Unupholstered | Delivered Pricing Fabric Grade 1 & C.O.M. | Delivered Pricing Fabric Grade 2 | Delivered Pricing Fabric Grade 3 | Delivered Pricing C.O.V. | Delivered Pricing Vinyl Group 2V | Delivered Pricing Pallas Fabric Group P0 | Delivered Pricing Pallas Fabric Group P1 | Delivered Pricing Pallas Fabric Group P2 | Delivered Pricing Pallas Fabric Group P3 | Delivered Pricing Pallas Fabric Group P4 |
|-------------------------|---------------------------------|---|----------------------------------|----------------------------------|--------------------------|----------------------------------|--|--|--|--|--|
| 31.0# | \$ 568 | | | | | | | | | | |
| 31.0# | 568 | | | | | | | | | | |
| 34.0# | N/A | 690 | 699 | 713 | 690 | 713 | 724 | 763 | 778 | 799 | 827 |
| 34.0# | N/A | 690 | 699 | 713 | 690 | 713 | 724 | 763 | 778 | 799 | 827 |
| 36.0# | N/A | 718 | 728 | 744 | 718 | 744 | 751 | 791 | 808 | 827 | 855 |
| 36.0# | N/A | 718 | 728 | 744 | 718 | 744 | 751 | 791 | 808 | 827 | 855 |
| 33.0# | \$ 625 | | | | | | | | | | |
| 33.0# | 625 | | | | | | | | | | |
| 36.0# | N/A | 747 | 756 | 771 | 747 | 771 | 779 | 821 | 836 | 855 | 884 |
| 36.0# | N/A | 747 | 756 | 771 | 747 | 771 | 779 | 821 | 836 | 855 | 884 |
| 37.0# | N/A | 775 | 785 | 801 | 775 | 801 | 808 | 849 | 864 | 884 | 913 |
| 37.0# | N/A | 775 | 785 | 801 | 775 | 801 | 808 | 849 | 864 | 884 | 913 |
| 32.0# | \$ 601 | | | | | | | | | | |
| 32.0# | 601 | | | | | | | | | | |
| 35.0# | N/A | 722 | 731 | 746 | 722 | 746 | 755 | 796 | 810 | 830 | 859 |
| 35.0# | N/A | 722 | 731 | 746 | 722 | 746 | 755 | 796 | 810 | 830 | 859 |
| 37.0# | N/A | 750 | 760 | 775 | 750 | 775 | 783 | 824 | 839 | 859 | 887 |
| 37.0# | N/A | 750 | 760 | 775 | 750 | 775 | 783 | 824 | 839 | 859 | 887 |

UPHOLSTERY INFORMATION

C.O.M. Upholstery

C.O.M. requirement for 10 chairs or less with upholstered seat or upholstered seat and back is 3/4 yard per chair of 54" wide nondirectional fabric. For orders of 11 or more with upholstered seat and back and for complete information on ordering C.O.M. see "Ordering C.O.M., C.O.V. and C.O.L." section.

California TB133 Fire Safety Code

For California Technical Bulletin 133 compliant models, add the following upcharge:

Model=Polypropylene
 Added List Price=\$10

Model=Upholstered Seat
 Added List Price=\$70

Model=Upholstered Seat and Back
 Added List Price=\$100

SPECIAL SERVICES

Special Carton Marking

With specially marked information N/C

Shipping

Ships **assembled, FOB Green Bay, WI 54302, freight prepaid.** Freight class 125.

Specifications and prices are subject to change without prior notice.

Stack/Nesting

Grazie® Chairs

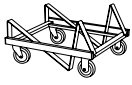
| | MODEL | MODEL NUMBER | Approx. Packaged Weight |
|--|--|----------------|-------------------------------|
| | | Basic Model | |
|  <p>HRDPT</p> | <p>Transport Dolly</p> <ul style="list-style-type: none"> • Easy maneuverability with 5" casters: two fixed, two swivel • Rugged weld tubular steel frame • Black powder-coat finish | GCD.BL | 32.0# |
| | | | |
| | | | |
| | | | |

A

HOW TO ORDER

Indicate the following information on order form:

1. Quantity of each item.
2. Model number, including options. See "How To Build a Model Number".
3. Any special service required.

Note: • The indicates that a choice is required.

- The absence of the indicates that no choice is required.
- Alpha-numeric characters in place of indicate that no other alternatives are available.

HOW TO BUILD A MODEL NUMBER

- A** Select basic model.



Delivered
Pricing

\$ 433

SPECIAL SERVICES

Special Carton Marking

With specially marked information N/C



Shipping

Ships **assembled, FOB Green Bay, WI 54302, freight prepaid.** Freight class 125.

Specifications and prices are subject to change without prior notice.

Stack/Nesting

Grazie® Cafe Stools

| MODEL | Features | MODEL NUMBER | | | | | | |
|---|-----------------------|--------------|--------------------------|--------------------------|--------------------------|--------------------------|--------------------------|--------------------------|
| | | Basic Model | Seat Height | Frame Color | Seat & Back Color | Glide Option | Fire Code | Upholstery Color |
|  <p>Four-Leg Armless Cafe Stool</p> <ul style="list-style-type: none"> Ergonomic articulation (Perfect Pivot) Stacking Two seat heights | Polypropylene | GLSNAP | <input type="checkbox"/> | <input type="checkbox"/> | <input type="checkbox"/> | <input type="checkbox"/> | <input type="checkbox"/> | |
| | Upholstered Seat | GLSNAU | <input type="checkbox"/> | <input type="checkbox"/> | <input type="checkbox"/> | <input type="checkbox"/> | <input type="checkbox"/> | <input type="checkbox"/> |
| | Upholstered Seat/Back | GLSNAUB | <input type="checkbox"/> | <input type="checkbox"/> | <input type="checkbox"/> | <input type="checkbox"/> | <input type="checkbox"/> | <input type="checkbox"/> |
| | | | | | | | | |
|  <p>Four-Leg Cantilever Arm Cafe Stool</p> <ul style="list-style-type: none"> Ergonomic articulation (Perfect Pivot) Stacking Two seat heights | Polypropylene | GLSCAP | <input type="checkbox"/> | <input type="checkbox"/> | <input type="checkbox"/> | <input type="checkbox"/> | <input type="checkbox"/> | |
| | Upholstered Seat | GLSCAU | <input type="checkbox"/> | <input type="checkbox"/> | <input type="checkbox"/> | <input type="checkbox"/> | <input type="checkbox"/> | <input type="checkbox"/> |
| | Upholstered Seat/Back | GLSCAUB | <input type="checkbox"/> | <input type="checkbox"/> | <input type="checkbox"/> | <input type="checkbox"/> | <input type="checkbox"/> | <input type="checkbox"/> |
| | | | | | | | | |

GLSP
GLSU
GLSUB

GLSP
GLSU
GLSUB

A **B** **C** **D** **E** **F** **G**

HOW TO ORDER

Indicate the following information on order form:

- Quantity of each item.
- Model number, including options. See "How To Build a Model Number".
- Any special service required.

Note: • The indicates that a choice is required.

- The absence of the indicates that no choice is required.
- Alpha-numeric characters in place of indicate that no other alternatives are available.

HOW TO BUILD A MODEL NUMBER

A Select basic model.

B Select seat height.
24 - 24" Seat Height
30 - 30" Seat Height

C Select frame color.
Refer to the **Product Color Options** page in this price list.

D Select poly seat and back color.
Refer to the **Product Color Options** page in this price list.

E Select glide option.
F - Felt Glides
P - Plastic glides
S - Steel glides

F Select fire code.

NFR - Compliance to TB 117-2013
FR - Compliance to TB 133
See Upholstery Information for TB133 upcharge.

G Select upholstery grade/color.
Refer to ki.com/fabrics



| Approx. Packaged Weight | Delivered Pricing Unupholstered | Delivered Pricing Fabric Grade 1 & C.O.M. | Delivered Pricing Fabric Grade 2 | Delivered Pricing Fabric Grade 3 | Delivered Pricing C.O.V. | Delivered Pricing Vinyl Group 2V | Delivered Pricing Pallas Fabric Group P0 | Delivered Pricing Pallas Fabric Group P1 | Delivered Pricing Pallas Fabric Group P2 | Delivered Pricing Pallas Fabric Group P3 | Delivered Pricing Pallas Fabric Group P4 |
|-------------------------|---------------------------------|---|----------------------------------|----------------------------------|--------------------------|----------------------------------|--|--|--|--|--|
| 32.0# | \$ 467 | | | | | | | | | | |
| 35.0# | N/A | 588 | 597 | 613 | 588 | 613 | 621 | 660 | 677 | 697 | 726 |
| 37.0# | N/A | 617 | 625 | 642 | 617 | 642 | 651 | 691 | 707 | 727 | 754 |
| 35.0# | \$ 580 | | | | | | | | | | |
| 38.0# | N/A | 701 | 710 | 726 | 701 | 726 | 735 | 775 | 791 | 810 | 838 |
| 40.0# | N/A | 730 | 738 | 755 | 730 | 755 | 763 | 803 | 820 | 838 | 866 |

UPHOLSTERY INFORMATION

C.O.M. Upholstery

C.O.M. requirement for 10 chairs or less with upholstered seat or upholstered seat and back is 3/4 yard per chair of 54" wide nondirectional fabric. For orders of 11 or more with upholstered seat and back and for complete information on ordering C.O.M. see "Ordering C.O.M., C.O.V. and C.O.L." section.

California TB133 Fire Safety Code

For California Technical Bulletin 133 compliant models, add the following upcharge:

Model=Polypropylene
Added List Price=\$10

Model=Upholstered Seat
Added List Price=\$70

Model=Upholstered Seat and Back
Added List Price=\$100

SPECIAL SERVICES

Special Carton Marking

With specially marked information N/C

Shipping

Ships **assembled, FOB Green Bay, WI 54302, freight prepaid.** Freight class 125.

Specifications and prices are subject to change without prior notice.

Stack/Nesting

Maestro® General Information



Stacking Chair (MSP)



Stacking Chair with Fixed Seat/Back Cushion (MSUSB)



Transport Dolly

| Features | | | |
|---|------------------------|------------------------|---------|
| Stackable | • | • | |
| Ganging | • | • | |
| Polypropylene seat and back | • | • | |
| Upholstered seat and back fixed cushion | | • | |
| General Dimensions | | | |
| Seat width | 18" | 18" | |
| Seat depth | 17-1/2" | 17-1/2" | |
| Seat height | 17-1/2" | 18" | |
| Floor to back height | 31-1/2" | 31-1/2" | |
| Overall Dimensions | | | |
| Width | 19-1/4" | 19-1/4" | 22-3/8" |
| Depth | 21-1/4" | 21-1/4" | 25-5/8" |
| Ganging on center | 20" | 20" | |
| Stacking on Dolly | | | |
| Width | 23" | 23" | |
| Depth | 42" | 42" | |
| Quantity/height | 38 Chairs/80" High | 15 Chairs/80" High | |
| Stacking on Floor | | | |
| Width | 19-1/4" | 19-1/4" | |
| Depth | 31" | 31" | |
| Quantity/height | 10 Chairs/38-3/4" High | 10 Chairs/38-3/4" High | |

SPECIFICATIONS

Seat and Backrest

Injection-molded polypropylene seat and back. Back features a contoured handle for easy lifting and stacking.

Seat and Back Pads

Fixed seat and back pads consist of a 3/16" thick plywood board with threaded inserts for attachment. The boards are covered in 1/2" foam padding and wrapped with fabric. The pads are attached to the seat and back with screws into the threaded fasteners.

Chair Frame

7/16" solid steel rod in bright nickel-chrome or with electrostatically-applied epoxy.

Bright Chrome Finish

Surfaces are duplex nickel-chrome plated in a twenty-one step process.

Powder-Coated Finish

Electrostatically-applied epoxy, baked onto surface. Stacking powder-coated frames is not recommended.

Transport Dolly

Tubular and plate steel welded together. 5" casters: two fixed, two swivel. Powder-coated finish.

INFORMATION

C.O.M. Testing and Production Requirements

Not all materials are suitable for upholstering this product. A 1 yd. x 54" sample must be submitted and approved prior to acceptance of an order. Upholstered chairs must be tested separately. If the fabric is directional in pattern or weave, the direction must be indicated on the submitted sample, and additional yardage may be requested. Customer's own vinyl and KI's 2V cannot be used on the MXU Matrix® model (upholstered seat/back, no cushion) but can be used on fixed cushion models.

Test samples must be sent to:

KI
Attn: C.O.M. Specialist
1687 Westminster Drive - Gate 3
Green Bay, WI 54302

Fabric Disclaimer

Fabric will be applied as swatched by the fabric manufacturer. Fabric that is required to be applied differently than is swatched will need a Special Cost Request written specifying the direction the fabric is to be applied. The posted standard lead time will apply to the Special Cost Request.



INFORMATION

Warranty

Refer to KI Terms & Conditions document
or visit ki.com

Stack/Nesting

Maestro® Color Options

Frame Color

| | |
|---------------------------|----|
| Antique Vein | AV |
| Black | BL |
| Blue Grey | GR |
| Bronze Metallic | ZM |
| Cayenne | CY |
| Champagne Metallic | CM |
| Chocolate | CT |
| Chrome | CH |
| Cool Grey | CG |
| Cottonwood | CO |
| Espresso Metallic | EX |
| Flannel | FN |
| Grass Green | GN |
| Light Tone | LG |
| Mardi Gras | MG |
| Misty Brown | MY |
| Nemo | NE |
| Nickel Vein | NK |
| Nordic | ND |
| Poppy Red | PR |
| Purple Haze | PH |
| Rubber Ducky | RK |
| Sand | SA |
| Sky Blue | SK |
| Splash | SH |
| Starlight Silver Metallic | SX |
| Surf's Up | SP |
| Ultra Blue | UB |
| Warm Grey | WG |
| Wet Sand | WS |
| Zesty Lime | ZL |

Seat and Back Color - Polypropylene Non Flame-Retardant

| | |
|--------------|-----|
| Black | PBL |
| Blue Grey | PGR |
| Cayenne | PCY |
| Chocolate | PCT |
| Cool Grey | PCG |
| Cottonwood | PCO |
| Flannel | PFN |
| Grass Green | PGN |
| Light Tone | PLG |
| Mardi Gras | PMG |
| Misty Brown | PMY |
| Nemo | PNE |
| Nordic | PND |
| Poppy Red | PPR |
| Purple Haze | PPH |
| Rubber Ducky | PRK |
| Sand | PSA |
| Sky Blue | PSK |
| Splash | PSH |
| Surf's Up | PSP |
| Ultra Blue | PUB |
| Warm Grey | PWG |
| Wet Sand | PWS |
| Zesty Lime | PZL |

Seat and Back Color - Polypropylene Flame-Retardant

| | |
|-------|-----|
| Black | PBL |
|-------|-----|

The above seating product can be manufactured using the appropriate flame-retardant materials for compliance to California Technical Bulletin 133.

Additional colors may be available. Please contact KI Customer Service at 1-800-424-2432.

Finish Cards

View color swatches for items listed within this document.

Paints

Wood/Veneer

Molded Edges

Hard Plastics

Plastics/Poly

Laminates



Edge Styles

Glass

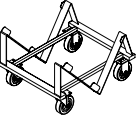

Stack/Nesting

Maestro®

| | MODEL | Features | MODEL NUMBER | | | | | | Approx. Packaged Weight | |
|---|---|---|-------------------------|--------------------------|--------------------------|--------------------------|--------------------------|--------------------------|--------------------------|-------|
| | | | Basic Model | Glide Option | Frame Color | Seat & Back Color | Fire Code | Upholstery Color | | |
|  | Stack Chair | Polypropylene | MSP | <input type="checkbox"/> | <input type="checkbox"/> | <input type="checkbox"/> | <input type="checkbox"/> | | 16.0# | |
| | | • Polypropylene seat and backrest | Fixed Seat Cushion | MSUS | <input type="checkbox"/> | <input type="checkbox"/> | <input type="checkbox"/> | <input type="checkbox"/> | <input type="checkbox"/> | 18.0# |
| | | • Polypropylene seat and back with upholstered seat cushion | Fixed Seat/Back Cushion | MSUSB | <input type="checkbox"/> | <input type="checkbox"/> | <input type="checkbox"/> | <input type="checkbox"/> | <input type="checkbox"/> | 20.0# |
| | | • Polypropylene seat and back with upholstered cushion on seat and back | | | | | | | | |
| | | • Steel rod frame in chrome or colors | | | | | | | | |
| | | • 38 chairs on the dolly stack to 80" high | | | | | | | | |
| MSP MSUS MSUSB | | | | | | | | | | |
|  | Transport Dolly for Poly Chairs | | CSD.BL | | | | | | 30.0# | |
| | | • Easy maneuverability with 5" casters; two fixed, two swivel | | | | | | | | |
| | | • Black powder-coated finish | | | | | | | | |
| HRDPT | | | | | | | | | | |
|  | Transport Dolly for Upholstered Chairs | | MFSD.BL | | | | | | 30.0# | |
| | | • Easy maneuverability with 5" casters; two fixed, two swivel | | | | | | | | |
| | | • Black powder-coated finish | | | | | | | | |
| HRDPT | | | | | | | | | | |

A **B** **C** **D** **E** **F**

HOW TO ORDER

Indicate the following information on order form:

- Quantity of each item.
- Model number, including options. See "How To Build a Model Number".
- Any special service required.

Note: • The indicates that a choice is required.

- The absence of the indicates that no choice is required.
- Alpha-numeric characters in place of indicate that no other alternatives are available.

HOW TO BUILD A MODEL NUMBER

A Select basic model.

B Select glide option.

G _____ - Ganging polycarbonate glides; add \$5

GS _____ - Ganging steel glides; add \$5

NG _____ - No glides

H _____ - Polycarbonate glides; add \$5

NS _____ - PVC non-skid glides; add \$5

S _____ - Stainless steel glides; add \$5

C Select frame color.

Refer to the **Product Color Options** page in this price list.

D Select seat and back color.

Refer to the **Product Color Options** page in this price list.

E Select fire code.

NFR _____ - No Fire Retardant

NFR _____ - Compliance to TB 117-2013

FR _____ - Compliance to TB 133

F Select upholstery grade/color.
Refer to ki.com/fabrics



| Delivered Pricing Unupholstered | Delivered Pricing Fabric Grade 1 & C.O.M. | Delivered Pricing Fabric Grade 2 | Delivered Pricing Fabric Grade 3 | Delivered Pricing Pallas Fabric Group P0 | Delivered Pricing Pallas Fabric Group P1 | Delivered Pricing Pallas Fabric Group P2 | Delivered Pricing Pallas Fabric Group P3 | Delivered Pricing Pallas Fabric Group P4 |
|------------------------------------|--|---|---|---|---|---|---|---|
| \$ 162 | | | | | | | | |
| N/A | 242 | 257 | 266 | 265 | 276 | 297 | 311 | 333 |
| N/A | 341 | 368 | 383 | 357 | 408 | 441 | 468 | 500 |

\$ 448

\$ 448

UPHOLSTERY INFORMATION

C.O.M. Upholstery

C.O.M. requirement for 10 chairs or less with upholstered seat or upholstered seat and back is 3/4 yard per chair of 54" wide nondirectional fabric. Requirement for orders of 11 or more with upholstered seat only is 1/2 yard per chair. For orders of 11 or more with upholstered seat and back and for complete information on ordering C.O.M. see "Ordering C.O.M., C.O.V. and C.O.L." section.

OPTIONS

California TB133 Fire Safety Code

For California Technical Bulletin 133 compliant models, add the following upcharge:

Model=Polypropylene
 Added Lead Time=1 week
 Added List Price=\$26

Model=Uph. Seat Pad Only
 Added Lead Time=N/A
 Added List Price=\$73

Model=Uph. Seat/Back Pad
 Added Lead Time=N/A
 Added List Price=\$88

SPECIAL SERVICES

Special Carton Marking

With specially marked information N/C

Shipping

Ships **assembled, FOB Green Bay, WI 54302, freight prepaid.** Freight class 125.

Specifications and prices are subject to change without prior notice.

Stack/Nesting

Matrix® General Information



**Armless Stacking
Chair (MX)**

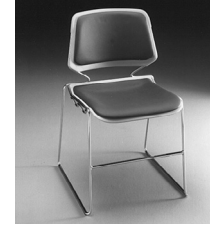

**Armless Stacking Chair with Fixed Seat/Back Cushion
(MXFSB)**

| Features | | |
|---|---------------------------|---------------------------|
| Ganging | • | • |
| Polypropylene seat and back | • | |
| Upholstered seat and back fixed cushion | | • |
| Overall Dimensions | | |
| Width | 18-7/8" (26" With Arm) | 18-7/8" (26" With Arm) |
| Depth | 21-3/4" | 21-3/4" |
| Height | 32-1/2" | 32-1/2" |
| Seat height | 18" | 18" |
| Stacking on Dolly | | |
| Polypropylene seat | 45 Chairs/79" High | |
| Fixed seat | | 15 Chairs/60" High |
| Fixed seat and back | | 16 Chairs/63-1/2" High |
| Depth | 37-1/2" | 37-1/2" |
| Stacking on Floor | | |
| Polypropylene seat | 15 Chairs/42" High | |
| Fixed seat | | 8 Chairs/44-1/2" High |
| Fixed seat and back | | 8 Chairs/44-1/2" High |

SPECIFICATIONS

Plastic Seats, Backrests and Armcaps

Injection-molded polypropylene.

Chair Frame

7/16" solid steel rod, bright duplex nickel chrome. Optional with electrostatically-applied epoxy (not recommended on tablet arm models).

Bright Chrome Finish

Surfaces are duplex nickel-chrome plated in a twenty-one step process.

Powder-Coated Finish

Electrostatically-applied epoxy, baked onto surface. Stacking and use of tablet arms on powder-coated frames not recommended.

Tablet Arm

7/16" solid steel rod frame, hinged tablet for easy access. Standard size has resin core; high-pressure laminate surface. Round tablet edge with clear lacquer finish.

Oversized has plywood core with clear lacquered edges. Black has black painted edges. Bright chrome frame only. Chairs are nonstacking when attached, not available for use with powder-coated frame chairs. Tablet flips up for easy access. Seating clearance is 14" for standard and oversized tablet arms. Standard tablet is 20-1/2" long and 12" wide. Oversized tablet is 20-1/2" long and 17" wide. Ganging with tablet is not recommended.

Tablet Arm on Upholstered Chair

It is recommended that the tablet arm not be removed after it is affixed to the chair.

Upholstery

"Fixed Seat and/or Back Cushions" have padded fabric only on the seat and on the front of the back. Both the seat and front of the back have plastic exposed around the cushions.

Stacking Vinyl, Polyurethane, and Imitation Leather Upholstered Chairs

It is recommended that chairs to be stacked be covered in material other than vinyl, polyurethane, or imitation leather as an impression in the seat may result. KI does not warrant the effects of stacking on stock or C.O.M. vinyl, polyurethane, or imitation leather upholstery.



**Transport Dolly
(Poly Chairs only)
(MXD.BL)**



**Transport Dolly
(Fixed Cushion Chairs)
(MVP.BL)**

Overall Dimensions

| | | |
|--------|---------|---------|
| Width | 22-3/8" | 22-3/8" |
| Depth | 25-5/8" | 25-5/8" |
| Height | | 14" |

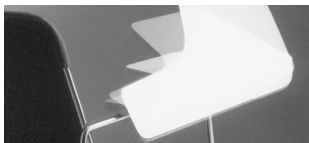

Tablet Arm

INFORMATION

C.O.M. Testing and Production Requirements

Not all materials are suitable for upholstering this product. A 1 yd. x 54" sample must be submitted and approved prior to acceptance of an order. Upholstered chairs must be tested separately. If the fabric is directional in pattern or weave, the direction must be indicated on the submitted sample, and additional yardage may be requested. Customer's own vinyl and KI's 2V cannot be used on the MXU Matrix® model (upholstered seat/back, no cushion) but can be used on fixed cushion models.

Test samples must be sent to:

KI
Attn: C.O.M. Specialist
1687 Westminster Drive - Gate 3
Green Bay, WI 54302

Fabric Disclaimer

Fabric will be applied as swatched by the fabric manufacturer. Fabric that is required to be applied differently than is swatched will need a Special Cost Request written specifying the direction the fabric is to be applied. The posted standard lead time will apply to the Special Cost Request.

INFORMATION

Warranty

Refer to KI Terms & Conditions document or visit ki.com

Stack/Nesting

Matrix® Color Options

Frame Color

| | |
|---------------------------|----|
| Antique Vein | AV |
| Black | BL |
| Blue Grey | GR |
| Bronze Metallic | ZM |
| Cayenne | CY |
| Champagne Metallic | CM |
| Chocolate | CT |
| Chrome | CH |
| Cool Grey | CG |
| Cottonwood | CO |
| Espresso Metallic | EX |
| Flannel | FN |
| Grass Green | GN |
| Light Tone | LG |
| Mardi Gras | MG |
| Misty Brown | MY |
| Nemo | NE |
| Nickel Vein | NK |
| Nordic | ND |
| Poppy Red | PR |
| Purple Haze | PH |
| Rubber Ducky | RK |
| Sand | SA |
| Sky Blue | SK |
| Splash | SH |
| Starlight Silver Metallic | SX |
| Surf's Up | SP |
| Ultra Blue | UB |
| Warm Grey | WG |
| Wet Sand | WS |
| Zesty Lime | ZL |

Seat and Back Color - Polypropylene Non Flame-Retardant

| | |
|--------------|-----|
| Black | PBL |
| Blue Grey | PGR |
| Cayenne | PCY |
| Chocolate | PCT |
| Cool Grey | PCG |
| Cottonwood | PCO |
| Flannel | PFN |
| Grass Green | PGN |
| Light Tone | PLG |
| Mardi Gras | PMG |
| Misty Brown | PMY |
| Nemo | PNE |
| Nordic | PND |
| Poppy Red | PPR |
| Purple Haze | PPH |
| Rubber Ducky | PRK |
| Sand | PSA |
| Sky Blue | PSK |
| Splash | PSH |
| Surf's Up | PSP |
| Ultra Blue | PUB |
| Warm Grey | PWG |
| Wet Sand | PWS |
| Zesty Lime | PZL |

Seat and Back Color - Polypropylene Flame-Retardant

| | |
|-------|-----|
| Black | PBL |
|-------|-----|

The above seating product can be manufactured using the appropriate flame-retardant materials for compliance to California Technical Bulletin 133.

Additional colors may be available. Please contact KI Customer Service at 1-800-424-2432.

Tablet Arm Color - Laminate

| | |
|--------------------|-----|
| Biltmore Cherry | LBT |
| Black | LBK |
| Brighton Walnut | LBW |
| Canyon Zephyr | LCA |
| Castle Oak | LCO |
| Casual Linen | LCU |
| Cherry Storm | LCX |
| Classic Linen | LCI |
| Cloud Zephyr | LCL |
| Cocobala | LCC |
| Coffee Bean | LCB |
| Crisp Linen | LRI |
| Desert Zephyr | LDZ |
| Dove Grey | LDG |
| Fired Steel | LIL |
| Flax Linen | LXF |
| Florence Walnut | LFC |
| Forged Steel | LOL |
| Frosty White | LFW |
| Graphite Nebula | LGN |
| Grey | LGE |
| High Rise | LHE |
| Hollyberry | LHY |
| Irish Linen | LIH |
| Island | LID |
| Italian Silver Ash | LIT |
| Kensington Maple | LKM |
| Lapis Blue | LLB |
| Markerboard White | LMK |
| Misted Zephyr | LMR |
| Monticello Maple | LMT |
| Nickel Evolv | LNV |
| North Sea | LNA |
| Ocean | LON |
| Orange Grove | LOE |
| Pearl Bisque | LPB |
| Pearl Silver | LPS |
| Pressed Linen | LPR |
| River Cherry | LRY |
| Rugged Linen | LRG |
| Satin Stainless | LSS |
| Shadow Zephyr | LSR |
| Silicon evolv | LSV |
| Sterling Ash | LAZ |
| Tailored Linen | LTL |
| Titanium evolv | LTV |
| White Nebula | LWL |
| White Sand | LWN |
| Windsor Mahogany | LWY |

Finish Cards

View color swatches for items listed within this document.

Paints

Wood/Veneer

Molded Edges

Hard Plastics

Plastics/Poly

Laminates



Edge Styles

Glass



Stack/Nesting

Matrix®

| MODEL | Features | MODEL NUMBER | | | | | | |
|--|-------------------------|--------------|---|---|---|---|---|------------------|
| | | Basic Model | Glide Option | Frame Color | Seat & Back Color | Fire Code | Uph. Color | Tablet Arm Color |
|  <p>Armless Stack Chair</p> <ul style="list-style-type: none"> • Polypropylene seat and backrest • Polypropylene seat and back with upholstered seat cushion • Polypropylene seat and back with upholstered cushions on seat and back • Steel rod frame in chrome or colors • Wire stacking bumper frame is standard on upholstered chair | Polypropylene | MX | <input type="checkbox"/> <input type="checkbox"/> | <input type="checkbox"/> <input type="checkbox"/> | <input type="checkbox"/> <input type="checkbox"/> <input type="checkbox"/> <input type="checkbox"/> | <input type="checkbox"/> <input type="checkbox"/> <input type="checkbox"/> <input type="checkbox"/> | | |
| | Fixed Seat Cushion | MXFS | <input type="checkbox"/> <input type="checkbox"/> | <input type="checkbox"/> <input type="checkbox"/> | <input type="checkbox"/> <input type="checkbox"/> <input type="checkbox"/> <input type="checkbox"/> | <input type="checkbox"/> <input type="checkbox"/> <input type="checkbox"/> <input type="checkbox"/> | <input type="checkbox"/> <input type="checkbox"/> <input type="checkbox"/> <input type="checkbox"/> | |
| | Fixed Seat/Back Cushion | MXFSB | <input type="checkbox"/> <input type="checkbox"/> | <input type="checkbox"/> <input type="checkbox"/> | <input type="checkbox"/> <input type="checkbox"/> <input type="checkbox"/> <input type="checkbox"/> | <input type="checkbox"/> <input type="checkbox"/> <input type="checkbox"/> <input type="checkbox"/> | <input type="checkbox"/> <input type="checkbox"/> <input type="checkbox"/> <input type="checkbox"/> | |
|  <p>Standard Flip-Up Tablet Arm</p> <ul style="list-style-type: none"> • NONSTACKING • 12" wide x 20-1/2" deep • Field installable • For use only on chrome framed chairs | Left Hand | MXTARM/STD/L | | | | | <input type="checkbox"/> <input type="checkbox"/> <input type="checkbox"/> <input type="checkbox"/> | |
| | Right Hand | MXTARM/STD/R | | | | | <input type="checkbox"/> <input type="checkbox"/> <input type="checkbox"/> <input type="checkbox"/> | |
|  <p>Oversize Flip-Up Tablet Arm</p> <ul style="list-style-type: none"> • NONSTACKING • 17" wide x 20-1/2" deep • Field installable • For use only on chrome framed chairs | Left Hand | MXTARM/OVS/L | | | | | <input type="checkbox"/> <input type="checkbox"/> <input type="checkbox"/> <input type="checkbox"/> | |
| | Right Hand | MXTARM/OVS/R | | | | | <input type="checkbox"/> <input type="checkbox"/> <input type="checkbox"/> <input type="checkbox"/> | |

A **B** **C** **D** **E** **F** **G**

HOW TO ORDER

Indicate the following information on order form:

1. Quantity of each item.
2. Model number, including options. See "How To Build a Model Number".
3. Any special service required.

Note: • The indicates that a choice is required.

- The absence of the indicates that no choice is required.
- Alpha-numeric characters in place of indicate that no other alternatives are available.

HOW TO BUILD A MODEL NUMBER

A Select basic model.

B Select glide option.

- G** _____ - Ganging polycarbonate glides; add \$5
- GS** _____ - Ganging steel glides; add \$5
- NG** _____ - No glides
- H** _____ - Polycarbonate glides; add \$5
- NS** _____ - PVC non-skid glides; add \$5
- S** _____ - Stainless steel glides; add \$5

C Select frame color.

Refer to the **Product Color Options** page in this price list.

D Select seat and back color.

Refer to the **Product Color Options** page in this price list.

E Select fire code.

- FR** _____ - Compliance to TB 133
- NFR** _____ - Compliance to TB 117-2013

F Select upholstery grade/color. Refer to ki.com/fabrics

G Select tablet arm color. Refer to the **Product Color Options** page in this price list.



| Approx. Packaged Weight | Delivered Pricing Unupholstered | Delivered Pricing Fabric Grade 1 & C.O.M. | Delivered Pricing Fabric Grade 2 | Delivered Pricing Fabric Grade 3 | Delivered Pricing C.O.V. | Delivered Pricing Vinyl Group 2V | Delivered Pricing Pallas Fabric Group P0 | Delivered Pricing Pallas Fabric Group P1 | Delivered Pricing Pallas Fabric Group P2 | Delivered Pricing Pallas Fabric Group P3 | Delivered Pricing Pallas Fabric Group P4 |
|-------------------------|---------------------------------|---|----------------------------------|----------------------------------|--------------------------|----------------------------------|--|--|--|--|--|
| 17.0# | \$ 235 | | | | | | | | | | |
| 19.0# | N/A | 315 | 331 | 336 | 315 | 336 | 338 | 348 | 368 | 383 | 404 |
| 21.0# | N/A | 414 | 440 | 457 | 414 | 457 | 431 | 483 | 515 | 541 | 572 |

| | |
|------|--------|
| 7.0# | \$ 190 |
| 7.0# | 190 |

| | |
|------|--------|
| 9.0# | \$ 249 |
| 9.0# | 249 |

UPHOLSTERY INFORMATION

C.O.M. Upholstery

C.O.M. requirement for 10 chairs or less is 1 yard per chair of 54" wide nondirectional fabric. For orders of 11 or more chairs and for complete information on ordering C.O.M. see "Ordering C.O.M., C.O.V. and C.O.L." section.

Custom-Matched Polypropylene Colors

Colors to be matched require a 3" x 3" swatch. Minimum order is 100 chairs. Additional lead time required.

OPTIONS

California TB133 Fire Safety Code

For California Technical Bulletin 133 compliant models, add the following upcharge:

Model=Polypropylene
Added Lead Time=1 week
Added List Price=\$27

Model=Upholstered
Added Lead Time=1 week
Added List Price=\$48

SPECIAL SERVICES

Special Carton Marking

With specially marked information N/C

Shipping

Ships **assembled, FOB Green Bay, WI 54302, freight prepaid.** Freight class 125.

Specifications and prices are subject to change without prior notice.

Stack/Nesting

Matrix®

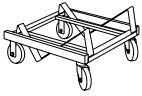
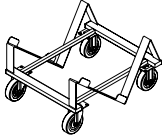
| | MODEL | MODEL NUMBER | |
|--|---|--------------|-------------------------|
| | | Basic Model | Approx. Packaged Weight |
|  HRDPT | Transport Dolly for Fixed Cushion Chairs • Easy maneuverability with 5" casters; two fixed, two swivel • Black powder-coated finish • For use with fixed cushion chairs | MVP.BL | 19.0# |
| | | | |
| | | | |
| | | | |
|  HRDPT | Transport Dolly for Poly Chairs • Easy maneuverability with 5" casters; two fixed, two swivel • Black powder-coated finish • For use with poly | MXD.BL | 30.0# |
| | | | |
| | | | |
| | | | |

A

HOW TO ORDER

Indicate the following information on order form:

1. Quantity of each item.
2. Model number, including options. See "How To Build a Model Number".
3. Any special service required.

Note: • The indicates that a choice is required.

- The absence of the indicates that no choice is required.
- Alpha-numeric characters in place of indicate that no other alternatives are available.

HOW TO BUILD A MODEL NUMBER

- A** Select basic model.



Delivered Pricing
Unupholstered

\$ 471

\$ 435

SPECIAL SERVICES

Special Carton Marking

With specially marked information N/C

Shipping

Ships **assembled, FOB Green Bay, WI 54302, freight prepaid.** Freight class 125.

Specifications and prices are subject to change without prior notice.

Stack/Nesting

Opt4® General Information



**Mesh Seat, Mesh Back
Four-Leg Chair
(O4LNAMSMB)**



**Mesh Seat, Poly Back
Four-Leg Chair
(O4LNAMSPB)**



**Poly Seat, Mesh Back
Four-Leg Chair
(O4LNAPSMB)**



**Poly Seat, Poly Back
Four-Leg Chair
(O4LNAPSPB)**



**Transport Dolly
(O4LD.BL)**

| Features | | | | | |
|----------------------------|-----------------------|-----------------------|-----------------------|-----------------------|---------|
| Stackable | • | • | • | • | |
| Mesh or poly seat and back | • | • | • | • | |
| General Dimensions | | | | | |
| Seat width | 17-1/2" | 17-1/2" | 17-1/2" | 17-1/2" | |
| Seat depth | 17-3/4" | 17-3/4" | 17-3/4" | 17-3/4" | |
| Seat height | 17-3/4" | 17-3/4" | 17-3/4" | 17-3/4" | |
| Overall Dimensions | | | | | |
| Width | 20-1/2" | 20-1/2" | 20-1/2" | 20-1/2" | 22-1/2" |
| Depth | 21-13/16" | 21-13/16" | 21-13/16" | 21-13/16" | 26-1/8" |
| Height | 32-3/16" | 32-3/16" | 32-3/16" | 32-3/16" | 15-1/2" |
| Stacking on dolly | | | | | |
| Overall width | 22-1/2" | 22-1/2" | 22-1/2" | 22-1/2" | |
| Overall depth | 37" | 37" | 37" | 37" | |
| Quantity/height | 15 Chairs/68" High | 15 Chairs/68" High | 15 Chairs/68" High | 15 Chairs/68" High | |
| Stacking on floor | | | | | |
| Quantity/height | 6 Chairs/43-1/2" High | 6 Chairs/43-1/2" High | 6 Chairs/43-1/2" High | 6 Chairs/43-1/2" High | |

SPECIFICATIONS

Frame

Frame is fabricated from 7/8" o.d. x 17-gauge tubular steel. All joints are welded.

Frame Finish

Baked-on, electrostatically-applied powder coating or bright nickel chrome plating.

Glides

Glides are molded from nylon. Available in black or stone grey.

Seat and Back

Seats and backs are available in four combinations of mesh and/or polypropylene. Polypropylene frame and mesh are monochromatic. An integral handle is available on the poly-back models. Opt4 seating is engineered to be eco-friendly. Mesh material is made from 100% post-consumer PET bottles. All resin parts (back, seat, and glides) are 100% recycled polypropylene.

Arms

Optional armrests are available. When equipped with arms, a formed steel tube is welded directly to the chair frame. Armcaps are polypropylene material.

Transport Dolly

Powder coated tubular steel frame. Two swivel casters and two fixed casters.

Design

Designed by Taku Kumazawa and axona AiCHI and manufactured in the USA by Krueger International, Inc.

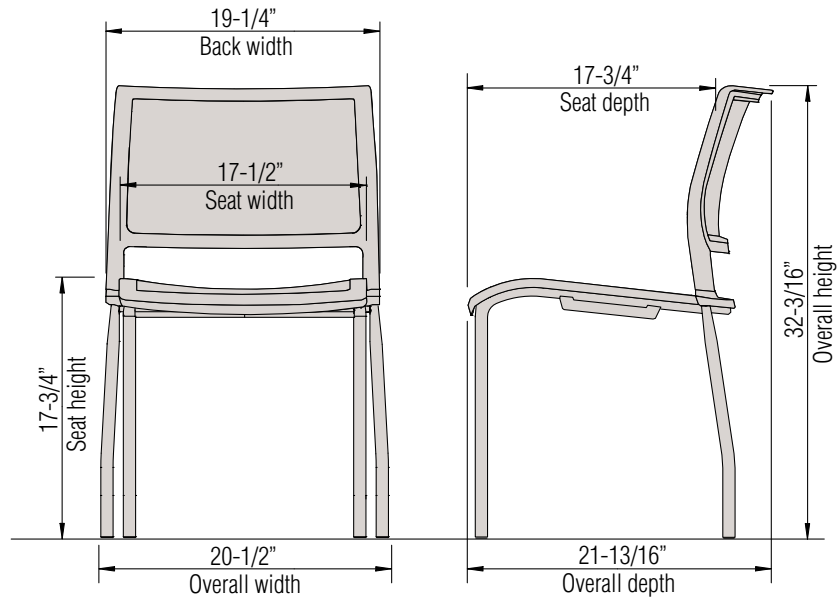

INFORMATION

Warranty

Refer to KI Terms & Conditions document
or visit ki.com

Stack/Nesting

Opt4® General Information



**Mesh Seat, Mesh Back
Four-Leg Arm Chair
(O4LWAMSMB)**



**Mesh Seat, Poly Back
Four-Leg Arm Chair
(O4LWAMSPB)**



**Poly Seat, Mesh Back
Four-Leg Arm Chair
(O4LWAPSMB)**



**Poly Seat, Poly Back
Four-Leg Armchair
(O4LWAPSPB)**

| Features | | | | |
|----------------------------|-----------------------|-----------------------|-----------------------|-----------------------|
| Stackable | • | • | • | • |
| Mesh or poly seat and back | • | • | • | • |
| General Dimensions | | | | |
| Seat width | 17-1/2" | 17-1/2" | 17-1/2" | 17-1/2" |
| Seat depth | 17-3/4" | 17-3/4" | 17-3/4" | 17-3/4" |
| Seat height | 17-3/4" | 17-3/4" | 17-3/4" | 17-3/4" |
| Overall Dimensions | | | | |
| Width | 24-5/8" | 24-5/8" | 24-5/8" | 24-5/8" |
| Depth | 21-13/16" | 21-13/16" | 21-13/16" | 21-13/16" |
| Height | 32-3/16" | 32-3/16" | 32-3/16" | 32-3/16" |
| Stacking on dolly | | | | |
| Overall width | 22-1/2" | 22-1/2" | 22-1/2" | 22-1/2" |
| Overall depth | 37" | 37" | 37" | 37" |
| Quantity/height | 15 Chairs/68" High | 15 Chairs/68" High | 15 Chairs/68" High | 15 Chairs/68" High |
| Stacking on floor | | | | |
| Quantity/height | 6 Chairs/43-1/2" High | 6 Chairs/43-1/2" High | 6 Chairs/43-1/2" High | 6 Chairs/43-1/2" High |

SPECIFICATIONS

Frame

Frame is fabricated from 7/8" o.d. x 17-gauge tubular steel. All joints are welded.

Frame Finish

Baked-on, electrostatically-applied powder coating or bright nickel chrome plating.

Glides

Glides are molded from nylon. Available in black or stone grey.

Seat and Back

Seats and backs are available in four combinations of mesh and/or polypropylene. Polypropylene frame and mesh are monochromatic. An integral handle is available on the poly-back models. Opt4 seating is engineered to be eco-friendly. Mesh material is made from 100% post-consumer PET bottles. All resin parts (back, seat, and glides) are 100% recycled polypropylene.

Arms

Optional armrests are available. When equipped with arms, a formed steel tube is welded directly to the chair frame. Armcaps are polypropylene material.

Transport Dolly

Powder coated tubular steel frame. Two swivel casters and two fixed casters.

Design

Designed by Taku Kumazawa and axona AiCHI and manufactured in the USA by Krueger International, Inc.

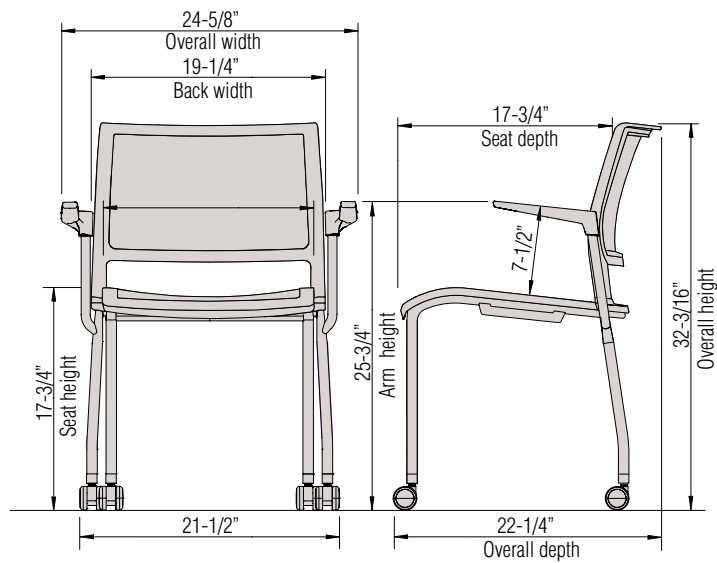
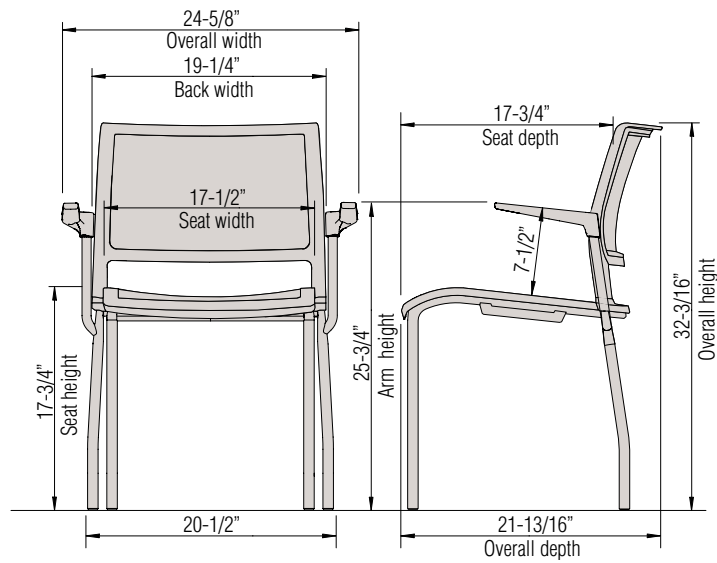

INFORMATION

Warranty

Refer to KI Terms & Conditions document or visit ki.com

Stack/Nesting

Opt4®



Mesh Seat, Mesh Back
Four-Leg Chair with Casters
(O4LNAMSMBC)



Mesh Seat, Poly Back
Four-Leg Chair with Casters
(O4LNAMPBC)



Poly Seat, Mesh Back
Four-Leg Chair with Casters
(O4LNAPSMBC)



Poly Seat, Poly Back
Four-Leg Chair with Casters
(O4LNAPSPBC)

| Features | | | | |
|----------------------------|-----------------------|-----------------------|-----------------------|-----------------------|
| Stackable | • | • | • | • |
| Mesh or poly seat and back | • | • | • | • |
| General Dimensions | | | | |
| Seat width | 17-1/2" | 17-1/2" | 17-1/2" | 17-1/2" |
| Seat depth | 17-3/4" | 17-3/4" | 17-3/4" | 17-3/4" |
| Seat height | 17-3/4" | 17-3/4" | 17-3/4" | 17-3/4" |
| Overall Dimensions | | | | |
| Width | 20-1/2" | 20-1/2" | 20-1/2" | 20-1/2" |
| Depth | 21-13/16" | 21-13/16" | 21-13/16" | 21-13/16" |
| Height | 32-3/16" | 32-3/16" | 32-3/16" | 32-3/16" |
| Stacking on floor | | | | |
| Quantity/height | 6 Chairs/43-1/2" High | 6 Chairs/43-1/2" High | 6 Chairs/43-1/2" High | 6 Chairs/43-1/2" High |

SPECIFICATIONS

Frame

Frame and front cross member are fabricated from 1/2" o.d. x 16-gauge tubular steel. All joints are welded.

Frame Finish

Baked-on, electrostatically-applied powder coating or bright nickel chrome plating.

Casters

Casters are double-wheel, high-impact thermoplastic. 50mm in diameter. Available in black.

Seat and Back

Seats and backs are available in four combinations of mesh and/or polypropylene. Plastic frame and mesh are monochromatic. An integral handle is available on the poly-back models. Opt4 seating is engineered to be eco-friendly. Mesh material is made from 100% post-consumer PET bottles. All resin parts (back, seat, and glides) are 100% recycled polypropylene.

Arms

Optional armrests are available. When equipped with arms, a formed steel tube is welded directly to the chair frame. Armcaps are polypropylene material.

Design

Designed by Taku Kumazawa and axona AICHI and manufactured in the USA by Krueger International, Inc.



Mesh Seat, Mesh Back
 Four-Leg Arm Chair with Casters
 (O4LWAMSMBC)



Mesh Seat, Poly Back
 Four-Leg Arm Chair with Casters
 (O4LWAMPBC)



Poly Seat, Mesh Back
 Four-Leg Arm Chair with Casters
 (O4LWAPSMBC)



Poly Seat, Poly Back
 Four-Leg Arm Chair with Casters
 (O4LWAPSPBC)

| Features | | | | |
|----------------------------|-----------------------|-----------------------|-----------------------|-----------------------|
| Stackable | • | • | • | • |
| Mesh or poly seat and back | • | • | • | • |
| General Dimensions | | | | |
| Seat width | 17-1/2" | 17-1/2" | 17-1/2" | 17-1/2" |
| Seat depth | 17-3/4" | 17-3/4" | 17-3/4" | 17-3/4" |
| Seat height | 17-3/4" | 17-3/4" | 17-3/4" | 17-3/4" |
| Overall Dimensions | | | | |
| Width | 24-5/8" | 24-5/8" | 24-5/8" | 24-5/8" |
| Depth | 21-13/16" | 21-13/16" | 21-13/16" | 21-13/16" |
| Height | 32-3/16" | 32-3/16" | 32-3/16" | 32-3/16" |
| Stacking on floor | | | | |
| Quantity/height | 6 Chairs/43-1/2" High | 6 Chairs/43-1/2" High | 6 Chairs/43-1/2" High | 6 Chairs/43-1/2" High |

INFORMATION

Warranty

Refer to KI Terms & Conditions document
 or visit ki.com

Stack/Nesting

Opt4® General Information



**Mesh Seat, Mesh Back
Sled Base Chair
(O4MSMB)**



**Mesh Seat, Poly Back
Sled Base Chair
(O4MSPB)**



**Poly Seat, Mesh Back
Sled Base Chair
(O4PSMB)**



**Poly Seat, Poly Back
Sled Base Chair
(O4PSPB)**



**Transport Dolly
(O4DA.BL)**

| Features | | | | | |
|----------------------------|------------------------|------------------------|------------------------|------------------------|---------|
| Stackable | • | • | • | • | |
| Ganging | • | • | • | • | |
| Mesh or poly seat and back | • | • | • | • | |
| General Dimensions | | | | | |
| Seat width | 17-1/2" | 17-1/2" | 17-1/2" | 17-1/2" | |
| Seat depth | 17-3/4" | 17-3/4" | 17-3/4" | 17-3/4" | |
| Seat height | 17-3/4" | 17-3/4" | 17-3/4" | 17-3/4" | |
| Overall Dimensions | | | | | |
| Width | 19-3/4" | 19-3/4" | 19-3/4" | 19-3/4" | 22-3/8" |
| Depth | 21-13/16" | 21-13/16" | 21-13/16" | 21-13/16" | 32" |
| Height | 32-3/16" | 32-3/16" | 32-3/16" | 32-3/16" | 16-3/4" |
| Stacking on dolly | | | | | |
| Overall width | 22-3/8" | 22-3/8" | 22-3/8" | 22-3/8" | |
| Overall depth | 38-1/4" | 38-1/4" | 38-1/4" | 38-1/4" | |
| Quantity/height | 38 Chairs/80" High | 38 Chairs/80" High | 38 Chairs/80" High | 38 Chairs/80" High | |
| Stacking on floor | | | | | |
| Quantity/height | 10 Chairs/40-1/4" High | 10 Chairs/40-1/4" High | 10 Chairs/40-1/4" High | 10 Chairs/40-1/4" High | |

SPECIFICATIONS

Frame

Frame and front cross member are fabricated from 1/2" o.d. x 16-gauge tubular steel. All joints are welded.

Frame Finish

Baked-on, electrostatically-applied powder coating or bright nickel chrome plating.

Glides

Glides are molded from a thermoplastic elastomer and can come with or without integral ganging clips. Glides are stone grey.

Seat and Back

Seats and backs are available in four combinations of mesh and/or polypropylene. Plastic frame and mesh are monochromatic. An integral handle is available on the poly-back models. Opt4 seating is engineered to be eco-friendly. Mesh material is made from 100% post-consumer PET bottles. All resin parts (back, seat, and glides) are 100% recycled polypropylene.

Transport Dolly

Powder coated tubular steel frame. Two swivel casters and two fixed casters.

Design

Designed by Taku Kumazawa and axona AICHI and manufactured in the USA by Krueger International, Inc.

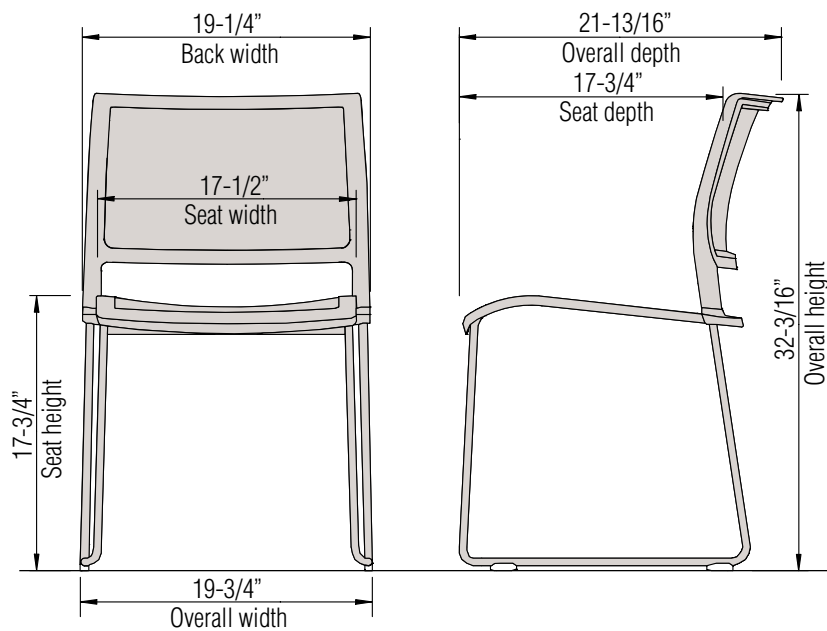

Dimensions are the same for all mesh/poly combination chairs.

INFORMATION

Warranty

Refer to KI Terms & Conditions document
or visit ki.com

Stack/Nesting

Opt4® General Information



Mesh Seat, Mesh Back
Stool
(O4SMSMB)



Mesh Seat, Poly Back
Stool
(O4SMSPB)



Poly Seat, Mesh Back
Stool
(O4SPSMB)



Poly Seat, Poly Back
Stool
(O4SPSPB)

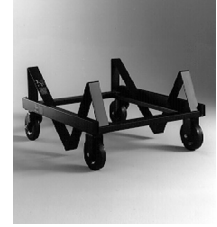

Transport Dolly
(O4SD.BL)

Features

| | | | | |
|----------------------------|---|---|---|---|
| Stackable | • | • | • | • |
| Ganging | • | • | • | • |
| Mesh or poly seat and back | • | • | • | • |

General Dimensions

| | | | | |
|-------------|---------|---------|---------|---------|
| Seat width | 17-1/2" | 17-1/2" | 17-1/2" | 17-1/2" |
| Seat depth | 17-3/4" | 17-3/4" | 17-3/4" | 17-3/4" |
| Seat height | 28-3/8" | 28-3/8" | 28-3/8" | 28-3/8" |

Overall Dimensions

| | | | | | |
|--------|---------|---------|---------|---------|---------|
| Width | 20-1/8" | 20-1/8" | 20-1/8" | 20-1/8" | 22-3/8" |
| Depth | 23" | 23" | 23" | 23" | 25-5/8" |
| Height | 42" | 42" | 42" | 42" | 14" |

| | | | | |
|-----------------|------------------------------|------------------------------|------------------------------|------------------------------|
| Height on dolly | 30 Chairs/80"H x 24"W x 52"D | 30 Chairs/80"H x 24"W x 52"D | 30 Chairs/80"H x 24"W x 52"D | 30 Chairs/80"H x 24"W x 52"D |
| Height on floor | 8 Chairs/48-1/2" High | 8 Chairs/48-1/2" High | 8 Chairs/48-1/2" High | 8 Chairs/48-1/2" High |

SPECIFICATIONS

Frame

Frame and front cross member are fabricated from 1/2" o.d. x 16-gauge tubular steel. All joints are welded.

Frame Finish

Baked-on, electrostatically-applied powder coating or bright nickel chrome plating.

Glides

Glides are molded from a thermoplastic elastomer and can come with or without integral ganging clips. Glides are stone grey.

Seat and Back

Seats and backs are available in four combinations of mesh and/or polypropylene. Plastic frame and mesh are monochromatic. An integral handle is available on the poly-back models. Opt4 seating is engineered to be eco-friendly. Mesh material is made from 100% post-consumer PET bottles. All resin parts (back, seat, and glides) are 100% recycled polypropylene.

Transport Dolly

Powder coated tubular steel frame. Two swivel casters and two fixed casters.

Design

Designed by Taku Kumazawa and axona AiCHI and manufactured in the USA by Krueger International, Inc.

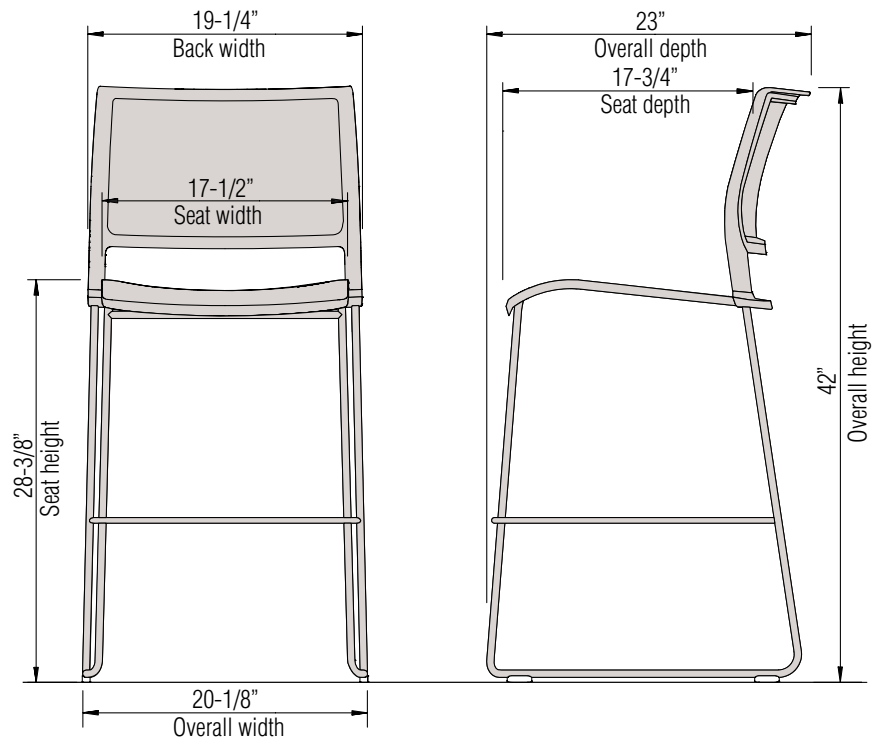

Dimensions are the same for all mesh/poly combination chairs.

INFORMATION

Warranty

Refer to KI Terms & Conditions document or visit ki.com

Stack/Nesting

Opt4® Color Options

Frame Color

| | |
|---------------------------|----|
| Antique Vein | AV |
| Black | BL |
| Blue Grey | GR |
| Bronze Metallic | ZM |
| Cayenne | CY |
| Champagne Metallic | CM |
| Chocolate | CT |
| Chrome | CH |
| Cool Grey | CG |
| Cottonwood | CO |
| Espresso Metallic | EX |
| Flannel | FN |
| Light Tone | LG |
| Mardi Gras | MG |
| Misty Brown | MY |
| Nemo | NE |
| Nickel Vein | NK |
| Nordic | ND |
| Purple Haze | PH |
| Rubber Ducky | RK |
| Sand | SA |
| Splash | SH |
| Starlight Silver Metallic | SX |
| Surf's Up | SP |
| Ultra Blue | UB |
| Warm Grey | WG |
| Wet Sand | WS |
| Zesty Lime | ZL |

Seat and Back Color - Poly and Mesh

| | |
|------------|------|
| Black | 04BL |
| Stone Grey | 04SG |
| White | 04WH |

Finish Cards

View color swatches for items listed within this document.

[Paints](#)

[Wood/Veneer](#)

[Molded Edges](#)

[Hard Plastics](#)

[Plastics/Poly](#)

[Laminates](#)





[Edge Styles](#)

[Glass](#)



Stack/Nesting

Opt4®

| | MODEL | Features | MODEL NUMBER | | | | | Approx. Packaged Weight |
|--|---|----------------------|--------------|--------------------------|--------------------------|--------------------------|--------------------------|-------------------------|
| | | | Basic Model | Frame Color | Fire Code | Seat & Back Color | Glide Option | |
|  <p>OPT4L</p> | Four-Leg Armless Chair • Stacking | Mesh Seat, Mesh Back | O4LNAMSMB | <input type="checkbox"/> | <input type="checkbox"/> | <input type="checkbox"/> | <input type="checkbox"/> | 12.0# |
|  <p>OPT4L</p> | Four-Leg Armless Chair • Stacking | Mesh Seat, Poly Back | O4LNAMSPB | <input type="checkbox"/> | NFR | <input type="checkbox"/> | <input type="checkbox"/> | 12.0# |
|  <p>OPT4L</p> | Four-Leg Armless Chair • Stacking | Poly Seat, Mesh Back | O4LNAPSMB | <input type="checkbox"/> | NFR | <input type="checkbox"/> | <input type="checkbox"/> | 12.0# |
|  <p>OPT4L</p> | Four-Leg Armless Chair • Stacking | Poly Seat, Poly Back | O4LNAPSPB | <input type="checkbox"/> | NFR | <input type="checkbox"/> | <input type="checkbox"/> | 12.0# |

A **B** **C** **D** **E**

HOW TO ORDER

Indicate the following information on order form:

- Quantity of each item.
- Model number, including options. See "How To Build a Model Number".
- Any special service required.

Note: • The indicates that a choice is required.

- The absence of the indicates that no choice is required.
- Alpha-numeric characters in place of indicate that no other alternatives are available.

HOW TO BUILD A MODEL NUMBER

- A** Select basic model.
- B** Select frame color.
Refer to the **Product Color Options** page in this price list.
- C** Select fire code. (Available on mesh seat/mesh back model only).

| | |
|------------|-----------------------------|
| FR | - Compliance to TB 133 |
| NFR | - Compliance to TB 117-2013 |
- D** Select poly and/or mesh seat and back color.
Refer to the **Product Color Options** page in this price list.
- E** Select glide option.

| | |
|------------|--------------------|
| GBL | - Black |
| GSG | - Stone Grey glide |



Delivered
Pricing

\$ 384

\$ 347

\$ 347

\$ 302

INFORMATION

California TB133 Fire Safety Code

Standard Opt4™ chair meets the California TB133 Fire Safety Code. No upcharge and no added lead time. (Available on mesh seat/mesh back model only.)

SPECIAL SERVICES

Special Carton Marking

With specially marked information N/C





Shipping

Ships **assembled, FOB Green Bay, WI 54302, freight prepaid.** Freight class 125.

Specifications and prices are subject to change without prior notice.

Stack/Nesting

Opt4®

| MODEL | Features | MODEL NUMBER | | | | | Approx. Packaged Weight |
|---|-------------------------------|--------------|--------------------------|--------------------------|--------------------------|--------------------------|-------------------------|
| | | Basic Model | Frame Color | Fire Code | Seat & Back Color | Caster Type | |
|  <p>Four-Leg Armless Chair with Casters</p> <ul style="list-style-type: none"> Stacking. Caution should be exercised to prevent casters from marring components such as frames, fabric, etc., and to prevent casters from becoming "hung up" underneath the seat of the chair Stacking on dollies NOT recommended | Mesh Seat, Mesh Back, Casters | O4LNAMSMBC | <input type="checkbox"/> | <input type="checkbox"/> | <input type="checkbox"/> | <input type="checkbox"/> | 13.0# |
| OPT4L | | | | | | | |
|  <p>Four-Leg Armless Chair with Casters</p> <ul style="list-style-type: none"> Stacking. Caution should be exercised to prevent casters from marring components such as frames, fabric, etc., and to prevent casters from becoming "hung up" underneath the seat of the chair Stacking on dollies NOT recommended | Mesh Seat, Poly Back, Casters | O4LNAMSPBC | <input type="checkbox"/> | NFR | <input type="checkbox"/> | <input type="checkbox"/> | 13.0# |
| OPT4L | | | | | | | |
|  <p>Four-Leg Armless Chair with Casters</p> <ul style="list-style-type: none"> Stacking. Caution should be exercised to prevent casters from marring components such as frames, fabric, etc., and to prevent casters from becoming "hung up" underneath the seat of the chair Stacking on dollies NOT recommended | Poly Seat, Mesh Back, Casters | O4LNAPSMBC | <input type="checkbox"/> | NFR | <input type="checkbox"/> | <input type="checkbox"/> | 13.0# |
| OPT4L | | | | | | | |
|  <p>Four-Leg Armless Chair with Casters</p> <ul style="list-style-type: none"> Stacking. Caution should be exercised to prevent casters from marring components such as frames, fabric, etc., and to prevent casters from becoming "hung up" underneath the seat of the chair Stacking on dollies NOT recommended | Poly Seat, Poly Back, Casters | O4LNAPSPBC | <input type="checkbox"/> | NFR | <input type="checkbox"/> | <input type="checkbox"/> | 13.0# |
| OPT4L | | | | | | | |

A **B** **C** **D** **E**

HOW TO ORDER

Indicate the following information on order form:

- Quantity of each item.
- Model number, including options. See "How To Build a Model Number".
- Any special service required.

Note: • The indicates that a choice is required.

- The absence of the indicates that no choice is required.
- Alpha-numeric characters in place of indicate that no other alternatives are available.

HOW TO BUILD A MODEL NUMBER

- A** Select basic model.
- B** Select frame color.
Refer to the **Product Color Options** page in this price list.
- C** Select fire code. (Available on mesh seat/mesh back model only).
FR - Compliance to TB 133
NFR - Compliance to TB 117-2013
- D** Select poly and/or mesh seat and back color.
Refer to the **Product Color Options** page in this price list.
- E** Select caster option.
S - Soft wheel casters
C - Carpet casters



Delivered
Pricing

\$ 423

\$ 387

\$ 387

\$ 340

INFORMATION

California TB133 Fire Safety Code

Standard Opt4™ chair meets the California TB133 Fire Safety Code. No upcharge and no added lead time. (Available on mesh seat/mesh back model only.)

SPECIAL SERVICES

Special Carton Marking

With specially marked information N/C





Shipping

Ships **assembled, FOB Green Bay, WI 54302, freight prepaid.** Freight class 125.

Specifications and prices are subject to change without prior notice.

Stack/Nesting

Opt4®

| | MODEL | Features | MODEL NUMBER | | | | | Approx. Packaged Weight |
|--|---|----------------------|--------------|--------------------------|--------------------------|--------------------------|--------------------------|-------------------------|
| | | | Basic Model | Frame Color | Fire Code | Seat & Back Color | Glide Option | |
|  <p>OPT4L</p> | Four-Leg Arm Chair • Stacking | Mesh Seat, Mesh Back | O4LWAMSMB | <input type="checkbox"/> | <input type="checkbox"/> | <input type="checkbox"/> | <input type="checkbox"/> | 12.0# |
|  <p>OPT4L</p> | Four-Leg Arm Chair • Stacking | Mesh Seat, Poly Back | O4LWAMSPB | <input type="checkbox"/> | NFR | <input type="checkbox"/> | <input type="checkbox"/> | 12.0# |
|  <p>OPT4L</p> | Four-Leg Arm Chair • Stacking | Poly Seat, Mesh Back | O4LWAPSMB | <input type="checkbox"/> | NFR | <input type="checkbox"/> | <input type="checkbox"/> | 12.0# |
|  <p>OPT4L</p> | Four-Leg Arm Chair • Stacking | Poly Seat, Poly Back | O4LWAPSPB | <input type="checkbox"/> | NFR | <input type="checkbox"/> | <input type="checkbox"/> | 12.0# |
| | | | | A | B | C | D | E |

HOW TO ORDER

Indicate the following information on order form:

- Quantity of each item.
- Model number, including options. See "How To Build a Model Number".
- Any special service required.

Note: • The indicates that a choice is required.

- The absence of the indicates that no choice is required.

- Alpha-numeric characters in place of indicate that no other alternatives are available.

HOW TO BUILD A MODEL NUMBER

- A** Select basic model.

- B** Select frame color.
Refer to the **Product Color Options** page in this price list.

- C** Select fire code. (Available on mesh seat/mesh back model only).

NFR - Compliance to TB 117-2013
FR - Compliance to TB 133

- D** Select poly and/or mesh seat and back color.
Refer to the **Product Color Options** page in this price list.

- E** Select glide option.

GBL - Black
GSG - Stone Grey glide



Delivered
Pricing

\$ 460

\$ 423

\$ 423

\$ 376

INFORMATION

California TB133 Fire Safety Code

Standard Opt4™ chair meets the California TB133 Fire Safety Code. No upcharge and no added lead time. (Available on mesh seat/mesh back model only.)

SPECIAL SERVICES

Special Carton Marking

With specially marked information N/C





Shipping

Ships **assembled, FOB Green Bay, WI 54302, freight prepaid.** Freight class 125.

Specifications and prices are subject to change without prior notice.

Stack/Nesting

Opt4®

| MODEL | Features | MODEL NUMBER | | | | | | |
|--|--|-------------------------------|-------------|--------------------------|--------------------------|--------------------------|--------------------------|--------------------------|
| | | Basic Model | Frame Color | Fire Code | Seat & Back Color | Caster Type | | |
|  <p>OPT4L</p> | <p>Four-Leg Armchair with Casters</p> <ul style="list-style-type: none"> Stacking. Caution should be exercised to prevent casters from marring components such as frames, fabric, etc., and to prevent casters from becoming "hung up" underneath the seat of the chair Stacking on dollies NOT recommended | Mesh Seat, Mesh Back, Casters | O4LWAMSMBC | <input type="checkbox"/> | <input type="checkbox"/> | <input type="checkbox"/> | <input type="checkbox"/> | <input type="checkbox"/> |
|  <p>OPT4L</p> | <p>Four-Leg Armchair with Casters</p> <ul style="list-style-type: none"> Stacking. Caution should be exercised to prevent casters from marring components such as frames, fabric, etc., and to prevent casters from becoming "hung up" underneath the seat of the chair Stacking on dollies NOT recommended | Mesh Seat, Poly Back, Casters | O4LWAMSPBC | <input type="checkbox"/> | NFR | <input type="checkbox"/> | <input type="checkbox"/> | <input type="checkbox"/> |
|  <p>OPT4L</p> | <p>Four-Leg Armchair with Casters</p> <ul style="list-style-type: none"> Stacking. Caution should be exercised to prevent casters from marring components such as frames, fabric, etc., and to prevent casters from becoming "hung up" underneath the seat of the chair Stacking on dollies NOT recommended | Poly Seat, Mesh Back, Casters | O4LWAPSMBC | <input type="checkbox"/> | NFR | <input type="checkbox"/> | <input type="checkbox"/> | <input type="checkbox"/> |
|  <p>OPT4L</p> | <p>Four-Leg Armchair with Casters</p> <ul style="list-style-type: none"> Stacking. Caution should be exercised to prevent casters from marring components such as frames, fabric, etc., and to prevent casters from becoming "hung up" underneath the seat of the chair Stacking on dollies NOT recommended | Poly Seat, Poly Back, Casters | O4LWAPSPBC | <input type="checkbox"/> | NFR | <input type="checkbox"/> | <input type="checkbox"/> | <input type="checkbox"/> |

A

B

C

D

E

HOW TO ORDER

Indicate the following information on order form:

- Quantity of each item.
- Model number, including options. See "How To Build a Model Number".
- Any special service required.

Note: • The indicates that a choice is required.

- The absence of the indicates that no choice is required.
- Alpha-numeric characters in place of indicate that no other alternatives are available.

HOW TO BUILD A MODEL NUMBER

A Select basic model.

B Select frame color.
Refer to the **Product Color Options** page in this price list.

C Select fire code. (Available on mesh seat/mesh back model only).

FR - Compliance to TB 133

NFR - Compliance to TB 117-2013

D Select poly and/or mesh seat and back color.

Refer to the **Product Color Options** page in this price list.

E Select caster option.

S - Soft wheel casters

C - Carpet casters



| Approx. Packaged Weight | Delivered Pricing |
|-------------------------------|----------------------|
| 13.0# | \$ 498 |

| | |
|-------|--------|
| 13.0# | \$ 462 |
|-------|--------|

| | |
|-------|--------|
| 13.0# | \$ 462 |
|-------|--------|

| | |
|-------|--------|
| 13.0# | \$ 416 |
|-------|--------|

INFORMATION

California TB133 Fire Safety Code

Standard Opt4™ chair meets the California TB133 Fire Safety Code. No upcharge and no added lead time. (Available on mesh seat/mesh back model only.)

SPECIAL SERVICES

Special Carton Marking

With specially marked information N/C





Shipping

Ships **assembled, FOB Green Bay, WI 54302, freight prepaid.** Freight class 125.

Specifications and prices are subject to change without prior notice.

Stack/Nesting

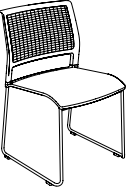
Opt4®

| | MODEL | Features | MODEL NUMBER | | | | | Approx. Packaged Weight |
|---|---|----------------------|--------------|---|---|---|---|-------------------------|
| | | | Basic Model | Frame Color | Fire Code | Seat & Back Color | Glide Option | |
|  | Sled Base Chair • Stacking • Ganging | Mesh Seat, Mesh Back | O4MSMB | <input type="checkbox"/> <input type="checkbox"/> | <input type="checkbox"/> <input type="checkbox"/> | <input type="checkbox"/> <input type="checkbox"/> <input type="checkbox"/> <input type="checkbox"/> | <input type="checkbox"/> <input type="checkbox"/> | 10.0 kg |
| OPT4 | | | | | | | | |
|  | Sled Base Chair • Stacking • Ganging | Mesh Seat, Poly Back | O4MSPB | <input type="checkbox"/> <input type="checkbox"/> | NFR | <input type="checkbox"/> <input type="checkbox"/> <input type="checkbox"/> <input type="checkbox"/> | <input type="checkbox"/> <input type="checkbox"/> | 10.0 kg |
| OPT4 | | | | | | | | |
|  | Sled Base Chair • Stacking • Ganging | Poly Seat, Mesh Back | O4PSMB | <input type="checkbox"/> <input type="checkbox"/> | NFR | <input type="checkbox"/> <input type="checkbox"/> <input type="checkbox"/> <input type="checkbox"/> | <input type="checkbox"/> <input type="checkbox"/> | 10.0 kg |
| OPT4 | | | | | | | | |
|  | Sled Base Chair • Stacking • Ganging | Poly Seat, Poly Back | O4PSPB | <input type="checkbox"/> <input type="checkbox"/> | NFR | <input type="checkbox"/> <input type="checkbox"/> <input type="checkbox"/> <input type="checkbox"/> | <input type="checkbox"/> <input type="checkbox"/> | 10.0 kg |
| OPT4 | | | | | | | | |

A

B

C

D

E

HOW TO ORDER

Indicate the following information on order form:

- Quantity of each item.
- Model number, including options. See "How To Build a Model Number".
- Any special service required.

Note: • The indicates that a choice is required.

- The absence of the indicates that no choice is required.
- Alpha-numeric characters in place of indicate that no other alternatives are available.

HOW TO BUILD A MODEL NUMBER

A Select basic model.

B Select frame color.
Refer to the **Product Color Options** page in this price list.

C Select fire code. (Available on mesh seat/mesh back model only).

NFR - Compliance to TB 117-2013
FR - Compliance to TB 133

D Select poly and/or mesh seat and back color.
Refer to the **Product Color Options** page in this price list.

E Select glide option.

G - Nylon glides, ganging
NG - Nylon glides, non-ganging
NS - PVC/Non-skid glides, non-ganging
S - Steel glides, non-ganging



Delivered
Pricing

\$ 341

\$ 289

\$ 289

\$ 226

INFORMATION

California TB133 Fire Safety Code

Standard Opt4™ chair meets the California TB133 Fire Safety Code. No upcharge and no added lead time. (Available on mesh seat/mesh back model only.)

Cartoning

4 chairs per carton

SPECIAL SERVICES

Special Carton Marking

With specially marked information N/C



Shipping

Ships **assembled, FOB Green Bay, WI 54302, freight prepaid.** Freight class 125.

Specifications and prices are subject to change without prior notice.

Stack/Nesting

Opt4® Cafe Stools

| MODEL | Features | MODEL NUMBER | | | | | Approx. Packaged Weight | |
|--|--|----------------------|-------------|--------------------------|--------------------------|--------------------------|--------------------------|-------|
| | | Basic Model | Frame Color | Fire Code | Seat & Back Color | Glide Option | | |
|  <p>OPT4S</p> | Cafe Stool • Stacking • Ganging | Mesh Seat, Mesh Back | O4SMSMB | <input type="checkbox"/> | <input type="checkbox"/> | <input type="checkbox"/> | <input type="checkbox"/> | 18.0# |
| | | | | | | | | |
| | | | | | | | | |
| | | | | | | | | |
| | | | | | | | | |
|  <p>OPT4S</p> | Cafe Stool • Stacking • Ganging | Mesh Seat, Poly Back | O4SMSPB | <input type="checkbox"/> | NFR | <input type="checkbox"/> | <input type="checkbox"/> | 18.0# |
| | | | | | | | | |
| | | | | | | | | |
| | | | | | | | | |
| | | | | | | | | |

A **B** **C** **D** **E**

HOW TO ORDER

Indicate the following information on order form:

- Quantity of each item.
- Model number, including options. See "How To Build a Model Number".
- Any special service required.

Note: • The indicates that a choice is required.

- The absence of the indicates that no choice is required.
- Alpha-numeric characters in place of indicate that no other alternatives are available.

HOW TO BUILD A MODEL NUMBER

- A** Select basic model.
- B** Select frame color.
Refer to the **Product Color Options** page in this price list.
- C** Select fire code. (Available on mesh seat/mesh back model only).

| | |
|------------|-----------------------------|
| NFR | - Compliance to TB 117-2013 |
| FR | - Compliance to TB 133 |
- D** Select poly and/or mesh seat and back color.
Refer to the **Product Color Options** page in this price list.
- E** Select glide option.

| | |
|-----------|------------------------------------|
| G | - Nylon glides, ganging |
| NG | - Nylon glides, non-ganging |
| NS | - PVC/Non-skid glides, non-ganging |
| S | - Steel glides, non-ganging |



Delivered
Pricing
\$ 482

\$ 430

INFORMATION

California TB133 Fire Safety Code

Standard Opt4™ chair meets the California TB133 Fire Safety Code. No upcharge and no added lead time. (Available on mesh seat/mesh back model only.)

Cartoning

2 stools per carton

SPECIAL SERVICES

Special Carton Marking

With specially marked information N/C

Shipping

Ships **assembled, FOB Green Bay, WI 54302, freight prepaid.** Freight class 125.

Specifications and prices are subject to change without prior notice.

Stack/Nesting

Opt4® Cafe Stools

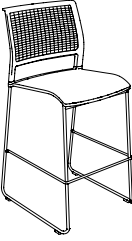
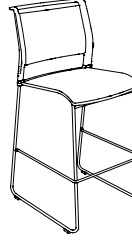
| MODEL | Features | MODEL NUMBER | | | | | Approx. Packaged Weight | |
|--|--|----------------------|-------------|--------------------------|-------------------|---|--------------------------|-------|
| | | Basic Model | Frame Color | Fire Code | Seat & Back Color | Glide Option | | |
|  <p>OPT4S</p> | <p>Cafe Stool</p> <ul style="list-style-type: none"> • Stacking • Ganging | Poly Seat, Mesh Back | 04SPSMB | <input type="checkbox"/> | NFR | <input type="checkbox"/> <input type="checkbox"/> <input type="checkbox"/> <input type="checkbox"/> | <input type="checkbox"/> | 18.0# |
| | | | | | | | | |
| | | | | | | | | |
| | | | | | | | | |
| | | | | | | | | |
|  <p>OPT4S</p> | <p>Cafe Stool</p> <ul style="list-style-type: none"> • Stacking • Ganging | Poly Seat, Poly Back | 04SPSPB | <input type="checkbox"/> | NFR | <input type="checkbox"/> <input type="checkbox"/> <input type="checkbox"/> <input type="checkbox"/> | <input type="checkbox"/> | 18.0# |
| | | | | | | | | |
| | | | | | | | | |
| | | | | | | | | |
| | | | | | | | | |

A **B** **C** **D** **E**

HOW TO ORDER

Indicate the following information on order form:

1. Quantity of each item.
2. Model number, including options. See "How To Build a Model Number".
3. Any special service required.

Note: • The indicates that a choice is required.

- The absence of the indicates that no choice is required.
- Alpha-numeric characters in place of indicate that no other alternatives are available.

HOW TO BUILD A MODEL NUMBER

- A** Select basic model.
- B** Select frame color.
Refer to the **Product Color Options** page in this price list.
- C** Select fire code. (Available on mesh seat/mesh back model only).

| | |
|------------|-----------------------------|
| NFR | - Compliance to TB 117-2013 |
| FR | - Compliance to TB 133 |
- D** Select poly and/or mesh seat and back color.
Refer to the **Product Color Options** page in this price list.
- E** Select glide option.

| | |
|-----------|------------------------------------|
| G | - Nylon glides, ganging |
| NG | - Nylon glides, non-ganging |
| NS | - PVC/Non-skid glides, non-ganging |
| S | - Steel glides, non-ganging |



Delivered
Pricing

\$ 430

\$ 365

INFORMATION

Cartoning

2 stools per carton

SPECIAL SERVICES

Special Carton Marking

With specially marked information N/C

Shipping

Ships **assembled, FOB Green Bay, WI 54302, freight prepaid.** Freight class 125.

Specifications and prices are subject to change without prior notice.

Stack/Nesting

Opt4®

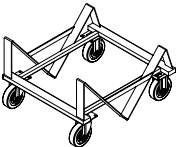
| | MODEL | MODEL NUMBER | Approx. Packaged Weight |
|--|--|--------------|-------------------------|
| | | Basic Model | |
| HRDPT | Transport Dolly for Four-Leg Chair <ul style="list-style-type: none"> • Easy maneuverability with 5" casters; two fixed, two swivel • Black powder-coated finish | O4LD.BL | 30.0# |
|  | Transport Dolly for Sled Base Chair <ul style="list-style-type: none"> • Easy maneuverability with 5" casters; two fixed, two swivel • Black powder-coated finish | O4DA.BL | 30.0# |
| | | | |
| HRDPT | Transport Dolly for Stool <ul style="list-style-type: none"> • Easy maneuverability with 5" casters; two fixed, two swivel • Black powder-coated finish | O4SD.BL | 30.0# |

A

HOW TO ORDER

Indicate the following information on order form:

1. Quantity of each item.
2. Model number, including options. See "How To Build a Model Number".
3. Any special service required.

Note: • The indicates that a choice is required.

- The absence of the indicates that no choice is required.
- Alpha-numeric characters in place of indicate that no other alternatives are available.

HOW TO BUILD A MODEL NUMBER

- A Select basic model.



Delivered
Pricing

\$ 422

\$ 422

\$ 447

SPECIAL SERVICES

Special Carton Marking

With specially marked information N/C

Shipping

Ships **assembled, FOB Green Bay, WI 54302, freight prepaid.** Freight class 125.

Specifications and prices are subject to change without prior notice.

Stack Seating

Plaza™ General Information



Guest Chair



Transport Dolly

General Dimensions

Seat height 17-1/4"

Overall Dimensions

Overall width 19-3/4" 18-1/2"

Overall depth 21-1/4" 37-1/4"

Overall height 31-1/4" 37-1/4"

Stacking on Dolly

Quantity/height 16 chairs/56" high

Stacking on Floor

Quantity/height 20 chairs



INFORMATION

Warranty
Refer to KI Terms & Conditions document
or visit ki.com

Stack/Nesting

Plaza® Color Options

Poly Color

| | |
|------------|----|
| Cottonwood | CO |
| Flannel | FN |
| Poppy Red | PR |
| Warm Grey | WG |

Finish Cards

View color swatches for items listed within this document.

Paints

Wood/Veneer

Molded Edges

Hard Plastics

Plastics/Poly

Laminates

Edge Styles

Glass



Stack Seating

Plaza™ Chair

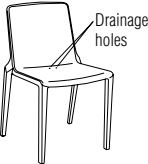
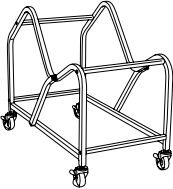
| | MODEL | MODEL NUMBER | | Approx. Packaged Weight |
|--|---|--------------|---|-------------------------|
| | | Basic Model | Poly Color | |
|  <p>PLZA</p> | Stack Chair <ul style="list-style-type: none"> • Polypropylene • UV resistant | PLAZA | <input type="checkbox"/> <input type="checkbox"/> <input type="checkbox"/> <input type="checkbox"/> | 15.0# |
|  <p>PLZA</p> | Stack Chair with Drain Holes <ul style="list-style-type: none"> • Polypropylene • UV resistant • Drainage holes in seat | PLZAOD | <input type="checkbox"/> <input type="checkbox"/> <input type="checkbox"/> <input type="checkbox"/> | 15.0# |
|  <p>HRDPT</p> | Transport Dolly | PLAZA.DOLLY | | 0.0# |

A

B

HOW TO ORDER

Indicate the following information on order form:

1. Quantity of each item.
2. Model number, including options. See "How To Build a Model Number".
3. Any special service required.

Note: • The indicates that a choice is required.

- The absence of the indicates that no choice is required.

- Alpha-numeric characters in place of indicate that no other alternatives are available.

HOW TO BUILD A MODEL NUMBER

A Select basic model.

B Select poly chair color. Refer to the **Product Color Options** page in this price list.



Stack Seating

Plaza™ Chair

Delivered
Pricing

\$ 160

\$ 166

\$ 160

SPECIAL SERVICES

Special Carton Marking

With specially marked information N/C

Shipping

Ships **assembled, FOB Tupelo, MS 38804, freight prepaid.** Freight class 150.

Specifications and prices are subject to change without prior notice.

Stack/Nesting

Rapture® General Information



**Four-Leg Stacking
Arm Chair
(RAPWAUS)**



**Four-Leg Stacking
Armless Chair
(RAPNAP)**



**Four-Leg Wallsaver
Arm Chair
(RAPWAUSWS)**



**Four-Leg Arm Chair
with Casters
(RAPWAUSC)**

| Features | | | | |
|---|---------|---------|---------|---------|
| Stackable | • | • | • | |
| Field-replaceable seat and back pad | • | • | • | • |
| Poly, upholstered, or combination of both | • | • | • | • |
| Arms | • | | • | • |
| General Dimensions | | | | |
| Seat width | 16-1/2" | 16-1/2" | 16-1/2" | 16-1/2" |
| Seat depth | 17" | 17" | 17" | 17" |
| Seat height | 18" | 18" | 18" | 18" |
| Floor to back height | 32" | 32" | 32" | 32" |
| Overall Dimensions | | | | |
| Width | 23-1/2" | 20-1/2" | 23-1/2" | 23-1/2" |
| Depth | 23" | 22" | 24-1/2" | 23" |
| Height | 32" | 32" | 32" | 32" |
| Top of arm to floor | 26-1/2" | | 26-1/2" | 26-1/2" |
| Stacking on Dolly | | | | |
| Width | 23-1/2" | 22-1/2" | | |
| Depth | 36" | 36" | | |
| Maximum quantity | 10 | 10 | | |
| Stacking on Floor | | | | |
| Maximum quantity | 6 | 6 | 6 | |

SPECIFICATIONS

Frame

Legs are 1" o.d. x 16-gauge tubular steel. Cross members are 1" o.d. x 14-gauge tubular steel. Side members are 7/8" o.d. x 14-gauge tubular steel. On the stools, the footring is made of steel wire. For both chairs and stools, all joints are welded. Wallsaver frame has an angled rear leg. Caster-based frame has a curved front leg.

Frame Finishes

Baked-on electrostatically-applied epoxy powder coating, or bright nickel-chrome plating.

Glides

Chrome plated steel or plastic.

Casters

Carpet casters available in black finish only.

Polypropylene Seat and Backrest

Injection-molded polypropylene

Upholstered Seat and Back

Molded urethane foam is attached to the seatboard, which is injection molded polypropylene. Slab urethane foam is attached to the back board, which is injection molded polypropylene. The boards are attached to the seat and back using four 10-24 x 3/8" truss head screws. Seat screws are not exposed. Backrest screws are exposed and are color matched to the polypropylene.

Armrests

Injection molded nylon. Armrests are attached to the backrest without fasteners. Arms are assembled over the backrest attachment tubes of the frame when the backrest is installed. The backrest is then locked in place using a patented "turn and lock" feature.

Tablet

Tablet measures 20-5/8 x 12"

Transport Dolly

Tubular steel frame, black powder-coated finish. Four 5" swivel wheels.

Stacking Vinyl, Polyurethane, and Imitation Leather Upholstered Chairs

It is recommended that chairs to be stacked be covered in material other than vinyl, polyurethane, or imitation leather as an impression in the seat may result. KI does not warrant the effects of stacking on stock or C.O.M. vinyl, polyurethane, or imitation leather upholstery.



**Cafe Stool with Arms
(SRAPWAUB)**



**Armless Cafe Stool
(SRAPNAP)**

Features

Stackable

Field-replaceable seat and back pad

Poly, upholstered, or combination of both

Arms

- | | | |
|--|---|---|
| | • | • |
| | • | • |
| | • | • |

General Dimensions

| | | |
|----------------------|---------|---------|
| Seat width | 16-1/2" | 16-1/2" |
| Seat depth | 17" | 17" |
| Seat height | 30" | 30" |
| Floor to back height | 44" | 44" |
| Top of arm to floor | 38-1/4" | |

Overall Dimensions

| | | |
|--------|---------|---------|
| Width | 23-1/2" | 20-1/2" |
| Depth | 23" | 22" |
| Height | 44" | 44" |

INFORMATION

C.O.M. Testing and Production Requirements

Not all materials are suitable for upholstering this product. A 1 yd. x 54" sample for any upholstery model must be submitted and approved prior to acceptance of an order. If the fabric is directional in pattern or weave, the direction must be indicated on the submitted sample, and additional yardage may be requested.

Test samples must be sent to:

KI
Attn: C.O.M. Specialist
1687 Westminster Drive - Gate 3
Green Bay, WI 54302

Fabric Disclaimer

Fabric will be applied as swatched by the fabric manufacturer. Fabric that is required to be applied differently than is swatched will need a Special Cost Request written specifying the direction the fabric is to be applied. The posted standard lead time will apply to the Special Cost Request.

Design

Designed by Giancarlo Piretti and manufactured in the USA by Krueger International, Inc. under license from Pro-Cord S.p.A.

INFORMATION

Warranty

Refer to KI Terms & Conditions document or visit ki.com

Stack/Nesting

Rapture® Color Options

Frame Color

| | |
|--------------|----|
| Antique Vein | AV |
| Black | BL |
| Blue Grey | GR |
| Chrome | CH |
| Cool Grey | CG |
| Flannel | FN |
| Light Tone | LG |
| Mardi Gras | MG |
| Misty Brown | MY |
| Nemo | NE |
| Nickel Vein | NK |
| Nordic | ND |
| Purple Haze | PH |
| Rubber Ducky | RK |
| Sand | SA |
| Surf's Up | SP |
| Ultra Blue | UB |
| Warm Grey | WG |
| Wet Sand | WS |
| Zesty Lime | ZL |

Seat and Back Color - Polypropylene Non Flame-Retardant

| | |
|--------------|-----|
| Black | PBL |
| Blue Grey | PGR |
| Cool Grey | PCG |
| Cottonwood | PCO |
| Flannel | PFN |
| Light Tone | PLG |
| Mardi Gras | PMG |
| Misty Brown | PMY |
| Nemo | PNE |
| Nordic | PND |
| Purple Haze | PPH |
| Rubber Ducky | PRK |
| Sand | PSA |
| Surf's Up | PSP |
| Ultra Blue | PUB |
| Warm Grey | PWG |
| Wet Sand | PWS |
| Zesty Lime | PZL |

Seat and Back Color - Polypropylene Flame-Retardant

| | |
|-------|-----|
| Black | PBL |
|-------|-----|

The above seating product can be manufactured using the appropriate flame-retardant materials for compliance to California Technical Bulletin 133.

Additional colors may be available. Please contact KI Customer Service at 1-800-424-2432.

Tablet Arm Color - Laminate

| | |
|--------------------|-----|
| Biltmore Cherry | LBT |
| Black | LBK |
| Brighton Walnut | LBW |
| Canyon Zephyr | LCA |
| Castle Oak | LCO |
| Casual Linen | LCU |
| Cherry Storm | LCX |
| Classic Linen | LCI |
| Cloud Zephyr | LCL |
| Cocobala | LCC |
| Coffee Bean | LCB |
| Crisp Linen | LRI |
| Desert Zephyr | LDZ |
| Dove Grey | LDG |
| Fired Steel | LIL |
| Flax Linen | LXF |
| Florence Walnut | LFC |
| Forged Steel | LOL |
| Frosty White | LFW |
| Graphite Nebula | LGN |
| Grey | LGE |
| High Rise | LHE |
| Hollyberry | LHY |
| Irish Linen | LIH |
| Island | LID |
| Italian Silver Ash | LIT |
| Kensington Maple | LKM |
| Lapis Blue | LLB |
| Markerboard White | LMK |
| Misted Zephyr | LMR |
| Monticello Maple | LMT |
| Nickel Evolv | LNV |
| North Sea | LNA |
| Ocean | LON |
| Orange Grove | LOE |
| Pearl Bisque | LPB |
| Pearl Silver | LPS |
| Pressed Linen | LPR |
| River Cherry | LRY |
| Rugged Linen | LRG |
| Satin Stainless | LSS |
| Shadow Zephyr | LSR |
| Silicon evolv | LSV |
| Sterling Ash | LAZ |
| Tailored Linen | LTL |
| Titanium evolv | LTV |
| White Nebula | LWL |
| White Sand | LWN |
| Windsor Mahogany | LWY |

Finish Cards

View color swatches for items listed within this document.

Paints

Wood/Veneer

Molded Edges

Hard Plastics

Plastics/Poly

Laminates



Edge Styles

Glass



Stack/Nesting

Rapture® Chairs

| | MODEL | Features | MODEL NUMBER | | | | | | Approx. Packaged Weight | | |
|--|-------------------------------|---|--------------------|-------------|--------------------------|--------------------------|--------------------------|--------------------------|--------------------------|--------------------------|-------|
| | | | Basic Model | Frame Color | Seat & Back Color | Glide Option | Fire Code | Upholstery Color | | | |
|  <p>RAPP RAPU</p> | Four-Leg Armless Chair | <ul style="list-style-type: none"> • Poly, upholstered, or combination of both • Field-replaceable seat & back pad • Stackable | Poly Seat/Back | RAPNAP | <input type="checkbox"/> | <input type="checkbox"/> | <input type="checkbox"/> | <input type="checkbox"/> | <input type="checkbox"/> | 19.0# | |
| | | | Uph Seat/Poly Back | RAPNAUS | <input type="checkbox"/> | <input type="checkbox"/> | <input type="checkbox"/> | <input type="checkbox"/> | <input type="checkbox"/> | <input type="checkbox"/> | 22.0# |
| | | | Uph Seat/Back | RAPNAUB | <input type="checkbox"/> | <input type="checkbox"/> | <input type="checkbox"/> | <input type="checkbox"/> | <input type="checkbox"/> | <input type="checkbox"/> | 23.0# |
| | | | | | | | | | | | |
|  <p>RAPP RAPU</p> | Four-Leg Arm Chair | <ul style="list-style-type: none"> • Poly, upholstered, or combination of both • Arm version • Field-replaceable seat & back pad • Stackable | Poly Seat/Back | RAPWAP | <input type="checkbox"/> | <input type="checkbox"/> | <input type="checkbox"/> | <input type="checkbox"/> | <input type="checkbox"/> | 21.0# | |
| | | | Uph Seat/Poly Back | RAPWAUS | <input type="checkbox"/> | <input type="checkbox"/> | <input type="checkbox"/> | <input type="checkbox"/> | <input type="checkbox"/> | <input type="checkbox"/> | 23.0# |
| | | | Uph Seat/Back | RAPWAUB | <input type="checkbox"/> | <input type="checkbox"/> | <input type="checkbox"/> | <input type="checkbox"/> | <input type="checkbox"/> | <input type="checkbox"/> | 24.0# |
| | | | | | | | | | | | |
|  <p>HRDPT</p> | Dolly | <ul style="list-style-type: none"> • Accommodates up to 10 chairs • Easy maneuverability with 5" casters: two fixed, two swivel • Black powder-coated finish | | RAPD.BL | | | | | | 32.0# | |
| | | | | | | | | | | | |
| | | | | | | | | | | | |
| | | | | | | | | | | | |

A **B** **C** **D** **E** **F**

HOW TO ORDER

Indicate the following information on order form:

1. Quantity of each item.
2. Model number, including options. See "How To Build a Model Number".
3. Any special service required.

Note: • The indicates that a choice is required.

- The absence of the indicates that no choice is required.
- Alpha-numeric characters in place of indicate that no other alternatives are available.

HOW TO BUILD A MODEL NUMBER

- A** Select basic model.
- B** Select frame color.
Refer to the **Product Color Options** page in this price list.
- C** Select seat and back color.
Refer to the **Product Color Options** page in this price list.
- D** Select glide option.
- | | |
|----------|------------------|
| P | - Plastic glides |
| S | - Steel glides |
- E** Select fire code.
- | | |
|------------|-----------------------------|
| FR | - Compliance to TB 133 |
| NFR | - Compliance to TB 117-2013 |
- F** Select upholstery grade/color.
Refer to ki.com/fabrics



| Delivered Pricing Upholstered | Delivered Pricing Fabric Grade 1 & C.O.M. | Delivered Pricing Fabric Grade 2 | Delivered Pricing Fabric Grade 3 | Delivered Pricing C.O.V. | Delivered Pricing Vinyl Group 2V | Delivered Pricing Pallas Fabric Group P0 | Delivered Pricing Pallas Fabric Group P1 | Delivered Pricing Pallas Fabric Group P2 | Delivered Pricing Pallas Fabric Group P3 | Delivered Pricing Pallas Fabric Group P4 | |
|-------------------------------|---|----------------------------------|----------------------------------|--------------------------|----------------------------------|--|--|--|--|--|-----|
| \$ 296 | N/A | 359 | 365 | 366 | 359 | 366 | 375 | 416 | 435 | 454 | 468 |
| N/A | 407 | 435 | 437 | 407 | 437 | 451 | 491 | 519 | 546 | 570 | |
| \$ 316 | N/A | 375 | 386 | 387 | 375 | 387 | 397 | 437 | 457 | 471 | 491 |
| N/A | 427 | 458 | 460 | 427 | 460 | 478 | 518 | 540 | 566 | 592 | |
| \$ 451 | | | | | | | | | | | |

UPHOLSTERY INFORMATION

C.O.M. Upholstery

C.O.M. requirement 1/2 yard per upholstered seat and 3/4 yard per upholstered seat and back of 54" wide nondirectional fabric. For complete information on ordering C.O.M., see "Ordering C.O.M., C.O.V. and C.O.L." section.

OPTIONS

California TB133 Fire Safety Code

For California Technical Bulletin 133 compliant models, add the following upcharge:

Model=Poly Seat/Back
 Added Lead Time=None
 Added List Price=\$34

Model=Uph Seat/Poly Back
 Added Lead Time=None
 Added List Price=\$100

Model=Uph Seat/Back
 Added Lead Time=None
 Added List Price=\$112

SPECIAL SERVICES

Special Carton Marking

With specially marked information N/C

Shipping

Ships **assembled, FOB Green Bay, WI 54302, freight prepaid.** Freight class 125.

Specifications and prices are subject to change without prior notice.

Stack/Nesting

Rapture® Chairs

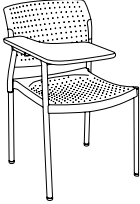
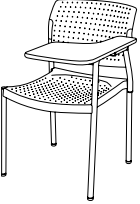
| Features | MODEL NUMBER | | | | | | | Approx. Packaged Weight | |
|--|----------------------------------|-------------|--------------------------|--------------------------|--------------------------|--------------------------|--------------------------|-------------------------|----------|
| | Basic Model | Frame Color | Seat & Back Color | Glide Option | Laminate Color | Fire Code | Upholstery Color | | |
|  <p>RAPP RAPU Four-Leg Tablet Arm Chair (Right Hand)</p> <ul style="list-style-type: none"> • Poly, upholstered, or combination of both • Field-replaceable seat & back pad • NONSTACKING | Right Tablet, Poly Seat/Back | RAPTARP | <input type="checkbox"/> | <input type="checkbox"/> | <input type="checkbox"/> | <input type="checkbox"/> | <input type="checkbox"/> | 21.0# | |
| | Right Tablet, Uph Seat/Poly Back | RAPTARUS | <input type="checkbox"/> | <input type="checkbox"/> | <input type="checkbox"/> | <input type="checkbox"/> | <input type="checkbox"/> | 24.0# | |
| | Right Tablet, Uph Seat/Back | RAPTARUB | <input type="checkbox"/> | <input type="checkbox"/> | <input type="checkbox"/> | <input type="checkbox"/> | <input type="checkbox"/> | 25.0# | |
|  <p>RAPP RAPU Four-Leg Tablet Arm Chair (Left Hand)</p> | Left Tablet, Poly Seat/Back | RAPTALP | <input type="checkbox"/> | <input type="checkbox"/> | <input type="checkbox"/> | <input type="checkbox"/> | <input type="checkbox"/> | 21.0# | |
| | Left Tablet, Uph Seat/Poly Back | RAPTALUS | <input type="checkbox"/> | <input type="checkbox"/> | <input type="checkbox"/> | <input type="checkbox"/> | <input type="checkbox"/> | 24.0# | |
| | Left Tablet, Uph Seat/Back | RAPTALUB | <input type="checkbox"/> | <input type="checkbox"/> | <input type="checkbox"/> | <input type="checkbox"/> | <input type="checkbox"/> | 25.0# | |
| | | | A | B | C | D | E | F | G |

HOW TO ORDER

Indicate the following information on order form:

1. Quantity of each item.
2. Model number, including options. See "How To Build a Model Number".
3. Any special service required.

Note: • The indicates that a choice is required.

- The absence of the indicates that no choice is required.
- Alpha-numeric characters in place of indicate that no other alternatives are available.

HOW TO BUILD A MODEL NUMBER

- A** Select basic model.
- B** Select frame color.
Refer to the **Product Color Options** page in this price list.
- C** Select seat and back color.
Refer to the **Product Color Options** page in this price list.
- D** Select glide option.

| | |
|----------|------------------|
| P | - Plastic glides |
| S | - Steel glides |
- E** Select tablet arm laminate.
Refer to the **Product Color Options** page in this price list.
- F** Select fire code.

| | |
|------------|-----------------------------|
| FR | - Compliance to TB 133 |
| NFR | - Compliance to TB 117-2013 |

G Select upholstery grade/color.
Refer to ki.com/fabrics



| Delivered Pricing Unupholstered | Delivered Pricing Fabric Grade 1 & C.O.M. | Delivered Pricing Fabric Grade 2 | Delivered Pricing Fabric Grade 3 | Delivered Pricing C.O.V. | Delivered Pricing Vinyl Group 2V | Delivered Pricing Pallas Fabric Group P0 | Delivered Pricing Pallas Fabric Group P1 | Delivered Pricing Pallas Fabric Group P2 | Delivered Pricing Pallas Fabric Group P3 | Delivered Pricing Pallas Fabric Group P4 | |
|---------------------------------|---|----------------------------------|----------------------------------|--------------------------|----------------------------------|--|--|--|--|--|-----|
| \$ 495 | N/A | 560 | 566 | 567 | 560 | 567 | 578 | 618 | 638 | 654 | 673 |
| N/A | 606 | 635 | 638 | 606 | 638 | 651 | 691 | 717 | 748 | 770 | |

| | | | | | | | | | | | |
|--------|-----|-----|-----|-----|-----|-----|-----|-----|-----|-----|-----|
| \$ 495 | N/A | 560 | 566 | 567 | 560 | 567 | 578 | 618 | 638 | 654 | 673 |
| N/A | 606 | 635 | 638 | 606 | 638 | 651 | 691 | 717 | 748 | 770 | |

UPHOLSTERY INFORMATION

C.O.M. Upholstery

C.O.M. requirement 1/2 yard per upholstered seat and 3/4 yard per upholstered seat and back of 54" wide nondirectional fabric. For complete information on ordering C.O.M., see "Ordering C.O.M., C.O.V. and C.O.L." section.

OPTIONS

California TB133 Fire Safety Code

For California Technical Bulletin 133 compliant models, add the following upcharge:

Model=Poly Seat/Back
Added Lead Time=None
Added List Price=\$34

Model=Uph Seat/Poly Back
Added Lead Time=None
Added List Price=\$100

Model=Uph Seat/Back
Added Lead Time=None
Added List Price=\$112

SPECIAL SERVICES

Special Carton Marking

With specially marked information N/C



Shipping

Ships **assembled, FOB Green Bay, WI 54302, freight prepaid.** Freight class 125.

Specifications and prices are subject to change without prior notice.

Stack/Nesting

Rapture® Chairs

| | MODEL | Features | MODEL NUMBER | | | | | | Approx. Packaged Weight | |
|--|---|---|--------------|--------------------------|--------------------------|--------------------------|--------------------------|--------------------------|--------------------------|-------|
| | | | Basic Model | Frame Color | Seat & Back Color | Glide Option | Fire Code | Upholstery Color | | |
|  <p>RAPP RAPU</p> | Four-Leg Wallsaver Armless Chair | <ul style="list-style-type: none"> Poly Seat/Back Uph Seat/Poly Back Uph Seat/Back Poly, upholstered, or combination of both Field-replaceable seat & back pad Stackable Wallsaver rear legs touch base of wall preventing chair back from contacting wall surface | RAPNAPWS | <input type="checkbox"/> | <input type="checkbox"/> | <input type="checkbox"/> | <input type="checkbox"/> | <input type="checkbox"/> | 19.0# | |
| | | | RAPNAUSWS | <input type="checkbox"/> | <input type="checkbox"/> | <input type="checkbox"/> | <input type="checkbox"/> | <input type="checkbox"/> | <input type="checkbox"/> | 22.0# |
| | | | RAPNAUBWS | <input type="checkbox"/> | <input type="checkbox"/> | <input type="checkbox"/> | <input type="checkbox"/> | <input type="checkbox"/> | <input type="checkbox"/> | 23.0# |
| | | | | | | | | | | |
|  <p>RAPP RAPU</p> | Four-Leg Wallsaver Arm Chair | <ul style="list-style-type: none"> Poly Seat/Back Uph Seat/Poly Back Uph Seat/Back Poly, upholstered, or combination of both Field-replaceable seat & back pad Stackable Wallsaver rear legs touch base of wall preventing chair back from contacting wall surface | RAPWAPWS | <input type="checkbox"/> | <input type="checkbox"/> | <input type="checkbox"/> | <input type="checkbox"/> | <input type="checkbox"/> | 21.0# | |
| | | | RAPWAUSWS | <input type="checkbox"/> | <input type="checkbox"/> | <input type="checkbox"/> | <input type="checkbox"/> | <input type="checkbox"/> | <input type="checkbox"/> | 23.0# |
| | | | RAPWAUBWS | <input type="checkbox"/> | <input type="checkbox"/> | <input type="checkbox"/> | <input type="checkbox"/> | <input type="checkbox"/> | <input type="checkbox"/> | 24.0# |
| | | | | | | | | | | |

A **B** **C** **D** **E** **F**

HOW TO ORDER

Indicate the following information on order form:

- Quantity of each item.
- Model number, including options. See "How To Build a Model Number".
- Any special service required.

Note: • The indicates that a choice is required.

- The absence of the indicates that no choice is required.
- Alpha-numeric characters in place of indicate that no other alternatives are available.

HOW TO BUILD A MODEL NUMBER

- A** Select basic model.
- B** Select frame color.
Refer to the **Product Color Options** page in this price list.
- C** Select seat and back color.
Refer to the **Product Color Options** page in this price list.
- D** Select glide option.

| | |
|----------|------------------|
| P | - Plastic glides |
| S | - Steel glides |
- E** Select fire code.

| | |
|------------|-----------------------------|
| NFR | - Compliance to TB 117-2013 |
| FR | - Compliance to TB 133 |
- F** Select upholstery grade/color.
Refer to ki.com/fabrics



| Delivered Pricing Unupholstered | Delivered Pricing Fabric Grade 1 & C.O.M. | Delivered Pricing Fabric Grade 2 | Delivered Pricing Fabric Grade 3 | Delivered Pricing C.O.V. | Delivered Pricing Vinyl Group 2V | Delivered Pricing Pallas Fabric Group P0 | Delivered Pricing Pallas Fabric Group P1 | Delivered Pricing Pallas Fabric Group P2 | Delivered Pricing Pallas Fabric Group P3 | Delivered Pricing Pallas Fabric Group P4 | |
|---------------------------------|---|----------------------------------|----------------------------------|--------------------------|----------------------------------|--|--|--|--|--|-----|
| \$ 332 | N/A | 395 | 401 | 402 | 395 | 402 | 414 | 454 | 471 | 491 | 506 |
| N/A | 443 | 470 | 471 | 443 | 471 | 488 | 527 | 556 | 583 | 606 | |
| \$ 353 | N/A | 414 | 422 | 423 | 414 | 423 | 432 | 471 | 492 | 510 | 527 |
| N/A | 464 | 493 | 496 | 464 | 496 | 516 | 555 | 578 | 602 | 629 | |

UPHOLSTERY INFORMATION

C.O.M. Upholstery

C.O.M. requirement 1/2 yard per upholstered seat and 3/4 yard per upholstered seat and back of 54" wide nondirectional fabric. For complete information on ordering C.O.M., see "Ordering C.O.M., C.O.V. and C.O.L." section.

OPTIONS

California TB133 Fire Safety Code

For California Technical Bulletin 133 compliant models, add the following upcharge:

Model=Poly Seat/Back
Added Lead Time=None
Added List Price=\$34

Model=Uph Seat/Poly Back
Added Lead Time=None
Added List Price=\$100

Model=Uph Seat/Back
Added Lead Time=None
Added List Price=\$112

SPECIAL SERVICES

Special Carton Marking

With specially marked information N/C



Shipping

Ships **assembled, FOB Green Bay, WI 54302, freight prepaid.** Freight class 125.

Specifications and prices are subject to change without prior notice.

Stack/Nesting

Rapture® Chairs

| | MODEL | Features | MODEL NUMBER | | | | | Approx. Packaged Weight | | |
|--|--|--|----------------|--------------------------|--------------------------|--------------------------|--------------------------|--------------------------|----------|--|
| | | | Basic Model | Frame Color | Seat & Back Color | Fire Code | Upholstery Color | | | |
|  <p>RAPP RAPU</p> | Four-Leg Armless Chair with Casters | <ul style="list-style-type: none"> Poly, upholstered, or combination of both Field-replaceable seat & back pad Stacking. Caution should be exercised to prevent casters from marring components such as frames, fabric, etc., and to prevent casters from becoming "hung up" underneath the seat of the chair below Stackable on dollies is NOT recommended | Poly Seat/Back | RAPNAPC | <input type="checkbox"/> | <input type="checkbox"/> | <input type="checkbox"/> | <input type="checkbox"/> | 19.0# | |
| | Uph Seat/Poly Back | | RAPNAUSC | <input type="checkbox"/> | <input type="checkbox"/> | <input type="checkbox"/> | <input type="checkbox"/> | <input type="checkbox"/> | 22.0# | |
| | Uph Seat/Back | | RAPNAUBC | <input type="checkbox"/> | <input type="checkbox"/> | <input type="checkbox"/> | <input type="checkbox"/> | <input type="checkbox"/> | 23.0# | |
| | | | | | | | | | | |
|  <p>RAPP RAPU</p> | Four-Leg Arm Chair with Casters | <ul style="list-style-type: none"> Poly, upholstered, or combination of both Arm version Field-replaceable seat & back pad Stacking. Caution should be exercised to prevent casters from marring components such as frames, fabric, etc., and to prevent casters from becoming "hung up" underneath the seat of the chair below Stackable on dollies is NOT recommended | Poly Seat/Back | RAPWAPC | <input type="checkbox"/> | <input type="checkbox"/> | <input type="checkbox"/> | <input type="checkbox"/> | 21.0# | |
| | Uph Seat/Poly Back | | RAPWAUSC | <input type="checkbox"/> | <input type="checkbox"/> | <input type="checkbox"/> | <input type="checkbox"/> | <input type="checkbox"/> | 23.0# | |
| | Uph Seat/Back | | RAPWAUBC | <input type="checkbox"/> | <input type="checkbox"/> | <input type="checkbox"/> | <input type="checkbox"/> | <input type="checkbox"/> | 24.0# | |
| | | | | | | | | | | |
| | | | | | A | B | C | D | E | |

HOW TO ORDER

Indicate the following information on order form:

- Quantity of each item.
- Model number, including options. See "How To Build a Model Number".
- Any special service required.

Note: • The indicates that a choice is required.

- The absence of the indicates that no choice is required.
- Alpha-numeric characters in place of indicate that no other alternatives are available.

HOW TO BUILD A MODEL NUMBER

- A** Select basic model.
- B** Select frame color.
Refer to the **Product Color Options** page in this price list.
- C** Select seat and back color.
Refer to the **Product Color Options** page in this price list.
- D** Select fire code.

| | |
|------------|-----------------------------|
| NFR | - Compliance to TB 117-2013 |
| FR | - Compliance to TB 133 |
- E** Select upholstery grade/color.
Refer to ki.com/fabrics



| Delivered Pricing Unupholstered | Delivered Pricing Fabric Grade 1 & C.O.M. | Delivered Pricing Fabric Grade 2 | Delivered Pricing Fabric Grade 3 | Delivered Pricing C.O.V. | Delivered Pricing Vinyl Group 2V | Delivered Pricing Pallas Fabric Group P0 | Delivered Pricing Pallas Fabric Group P1 | Delivered Pricing Pallas Fabric Group P2 | Delivered Pricing Pallas Fabric Group P3 | Delivered Pricing Pallas Fabric Group P4 | |
|---------------------------------|---|----------------------------------|----------------------------------|--------------------------|----------------------------------|--|--|--|--|--|-----|
| \$ 407 | N/A | 467 | 474 | 479 | 467 | 479 | 487 | 526 | 549 | 564 | 581 |
| N/A | 519 | 549 | 550 | 519 | 550 | 562 | 602 | 629 | 657 | 681 | |
| \$ 427 | N/A | 489 | 496 | 497 | 489 | 497 | 511 | 550 | 567 | 586 | 602 |
| N/A | 539 | 568 | 571 | 539 | 571 | 588 | 628 | 651 | 678 | 705 | |

UPHOLSTERY INFORMATION

C.O.M. Upholstery

C.O.M. requirement 1/2 yard per upholstered seat and 3/4 yard per upholstered seat and back of 54" wide nondirectional fabric. For complete information on ordering C.O.M., see "Ordering C.O.M., C.O.V. and C.O.L." section.

OPTIONS

California TB133 Fire Safety Code

For California Technical Bulletin 133 compliant models, add the following upcharge:

Model=Poly Seat/Back
Added Lead Time=None
Added List Price=\$34

Model=Uph Seat/Poly Back
Added Lead Time=None
Added List Price=\$100

Model=Uph Seat/Back
Added Lead Time=None
Added List Price=\$112

SPECIAL SERVICES

Special Carton Marking

With specially marked information N/C

Shipping

Ships **assembled, FOB Green Bay, WI 54302, freight prepaid.** Freight class 125.

Specifications and prices are subject to change without prior notice.

Stack/Nesting

Rapture® Cafe Stools

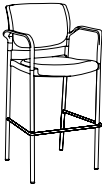
| | MODEL | Features | MODEL NUMBER | | | | | | Approx. Packaged Weight |
|---|---|--------------------|--------------|--------------------------|--------------------------|--------------------------|--------------------------|--------------------------|-------------------------|
| | | | Basic Model | Frame Color | Seat & Back Color | Glide Option | Fire Code | Upholstery Color | |
|  | Four-Leg Armless Cafe Stool • Poly, upholstered, or combination of both • Field-replaceable seat & back pad | Poly Seat/Back | SRAPNAP | <input type="checkbox"/> | <input type="checkbox"/> | <input type="checkbox"/> | <input type="checkbox"/> | <input type="checkbox"/> | 29.0# |
| | | Uph Seat/Poly Back | SRAPNAPB | <input type="checkbox"/> | <input type="checkbox"/> | <input type="checkbox"/> | <input type="checkbox"/> | <input type="checkbox"/> | 31.0# |
| | | Uph Seat/Back | SRAPNAUB | <input type="checkbox"/> | <input type="checkbox"/> | <input type="checkbox"/> | <input type="checkbox"/> | <input type="checkbox"/> | 33.0# |
| | | | | | | | | | |
| SRAPP | | | | | | | | | |
| SRAPU | | | | | | | | | |
|  | Four-Leg Cafe Stool with Arms • Poly, upholstered, or combination of both • Arm version • Field-replaceable seat & back pad | Poly Seat/Back | SRAPWAP | <input type="checkbox"/> | <input type="checkbox"/> | <input type="checkbox"/> | <input type="checkbox"/> | <input type="checkbox"/> | 31.0# |
| | | Uph Seat/Poly Back | SRAPWAPB | <input type="checkbox"/> | <input type="checkbox"/> | <input type="checkbox"/> | <input type="checkbox"/> | <input type="checkbox"/> | 33.0# |
| | | Uph Seat/Back | SRAPWAUB | <input type="checkbox"/> | <input type="checkbox"/> | <input type="checkbox"/> | <input type="checkbox"/> | <input type="checkbox"/> | 35.0# |
| | | | | | | | | | |
| SRAPP | | | | | | | | | |
| SRAPU | | | | | | | | | |

A **B** **C** **D** **E** **F**

HOW TO ORDER

Indicate the following information on order form:

- Quantity of each item.
- Model number, including options. See "How To Build a Model Number".
- Any special service required.

Note: • The indicates that a choice is required.

- The absence of the indicates that no choice is required.
- Alpha-numeric characters in place of indicate that no other alternatives are available.

HOW TO BUILD A MODEL NUMBER

- A** Select basic model.
- B** Select frame color.
Refer to the **Product Color Options** page in this price list.
- C** Select seat and back color.
Refer to the **Product Color Options** page in this price list.
- D** Select glide option.

| | |
|----------|------------------|
| P | - Plastic glides |
| S | - Steel glides |
- E** Select fire code.

| | |
|------------|-----------------------------|
| FR | - Compliance to TB 133 |
| NFR | - Compliance to TB 117-2013 |
- F** Select upholstery grade/color.
Refer to ki.com/fabrics



| Delivered Pricing Unupholstered | Delivered Pricing Fabric Grade 1 & C.O.M. | Delivered Pricing Fabric Grade 2 | Delivered Pricing Fabric Grade 3 | Delivered Pricing C.O.V. | Delivered Pricing Vinyl Group 2V | Delivered Pricing Pallas Fabric Group P0 | Delivered Pricing Pallas Fabric Group P1 | Delivered Pricing Pallas Fabric Group P2 | Delivered Pricing Pallas Fabric Group P3 | Delivered Pricing Pallas Fabric Group P4 | |
|---------------------------------|---|----------------------------------|----------------------------------|--------------------------|----------------------------------|--|--|--|--|--|-----|
| \$ 648 | N/A | 711 | 718 | 719 | 711 | 719 | 731 | 771 | 796 | 810 | 827 |
| N/A | 763 | 798 | 799 | 763 | 799 | 809 | 850 | 878 | 908 | 931 | |

| | | | | | | | | | | | |
|--------|-----|-----|-----|-----|-----|-----|-----|-----|-----|-----|-----|
| \$ 671 | N/A | 733 | 740 | 744 | 733 | 744 | 757 | 798 | 812 | 832 | 850 |
| N/A | 782 | 813 | 817 | 782 | 817 | 832 | 872 | 900 | 928 | 954 | |

UPHOLSTERY INFORMATION

C.O.M. Upholstery

C.O.M. requirement 1/2 yard per upholstered seat and 3/4 yard per upholstered seat and back of 54" wide nondirectional fabric. For complete information on ordering C.O.M., see "Ordering C.O.M., C.O.V. and C.O.L." section.

OPTIONS

California TB133 Fire Safety Code

For California Technical Bulletin 133 compliant models, add the following upcharge:

Model=Poly Seat/Back
Added Lead Time=None
Added List Price=\$34

Model=Uph Seat/Poly Back
Added Lead Time=None
Added List Price=\$100

Model=Uph Seat/Back
Added Lead Time=None
Added List Price=\$112

SPECIAL SERVICES

Special Carton Marking

With specially marked information N/C

Shipping

Ships **assembled, FOB Green Bay, WI 54302, freight prepaid.** Freight class 125.

Specifications and prices are subject to change without prior notice.

Stack/Nesting

Strive® General Information



Armless Four-Leg Chair (SLNAU)



Four-Leg Cantilever Arm Chair (SLCAP)



Four-Leg Loop Arm Chair (SLLAU)



Four-Leg Tablet Arm Chair (SLTAPRH)



Four-Leg Oversize Tablet Arm Chair (SLOVTAURH)



Four-Leg Cantilever Arm Cafe Stool - 24" or 30" Seat Height (SLSCAUB)

| Features | | | | | | |
|--|--------------------|--------------------|--------------------|---------|---------|--------------------------|
| Stackable | • | • | • | | | • |
| Poly, upholstered seat, or upholstered seat/back | • | • | • | • | • | • |
| Flex back | • | • | • | • | • | • |
| General Dimensions | | | | | | |
| Seat width | 18" | 18" | 18" | 18" | 18" | 18" |
| Seat depth | 18" | 18" | 18" | 18" | 18" | 18" |
| Seat height (upholstered add 1") | 17-1/2" | 17-1/2" | 17-1/2" | 17-1/2" | 17-1/2" | 24" / 30" |
| Tablet to chair back clearance | | | | 14" | 14" | |
| Overall Dimensions | | | | | | |
| Width | 20-3/4" | 25" | 25" | 24" | 24" | 25" |
| Depth | 21-3/4" | 21-3/4" | 21-3/4" | 27-3/4" | 31" | 23-1/2" / 25" |
| Height | 33" | 33" | 33" | 33" | 33" | 39-1/4" / 45-1/4" |
| Arms to floor | | 26-1/4" | 26-1/4" | 28-1/2" | 28-1/2" | 32-1/2" / 38-1/2" |
| Stacking on Dolly | | | | | | |
| Overall width | 24" | 25" | 25" | | | |
| Overall depth - poly | 40" | 40" | 40" | | | |
| Quantity/height - poly | 15 Chairs/61" High | 15 Chairs/62" High | 15 Chairs/63" High | | | |
| Overall depth - upholstered | 45" | 45" | 45" | | | |
| Quantity/height - upholstered | 8 Chairs/50" High | 8 Chairs/51" High | 8 Chairs/51" High | | | |
| Stacking on Floor | | | | | | |
| Width | 20-3/4" | 25" | 25" | | | 25-7/8" |
| Depth | 27-1/2" | 27-1/2" | 27-1/2" | | | 28" |
| Quantity/height | 4 Chairs/39" High | 4 Chairs/39" High | 4 Chairs/39" High | | | 4 Chairs/48" or 54" High |

SPECIFICATIONS

Frame

Legs are 7/8" o.d. x 13-gauge tubular steel. Cross members are 1" o.d. x 14-gauge tubular steel and 7/16" diameter solid steel. All joints are welded. Frames are available in 4-leg or sled base configurations.

Frame Finishes

Baked-on electrostatically-applied 45° gloss epoxy powder coating or bright nickel-chrome plating.

Backrest

Injection molded polypropylene with integral steel cantilever springs. The combination of the slotted polypropylene back and the spring steel provides a supportive flexing back. Springs are nominal 4.5mm diameter chrome silicon valve spring wire.

Optional Upholstered Seat

Molded urethane foam is attached to an injection molded polypropylene seat board,

then upholstered using a draw-string process. The assembled seat pad is attached to the seat by means of hidden fasteners.

Optional Upholstered Back

1/2" thick urethane foam is attached to an injection molded polypropylene back board, then upholstered using a draw-string process. The assembled back pad is attached to the back by means of fasteners which are exposed and are color matched to the polypropylene.

Seat and Shroud

Injection molded polypropylene.

Arms

Optional cantilever arms or loop arms are available. When equipped with arms, the supporting structure is a continuation of the rear leg finished to match the frame color. The armcaps are injection molded nylon matching the frame finish (except for chrome, hammertone, and metallic finishes which will match poly color. Diamond

translucent poly will have light tone armrests; Pewter translucent will have flannel armrests; Bronze translucent will have chocolate armrests). The armcaps are attached to the steel structure by means of screws.

Tablet Arm

Tablet support loop is a continuation of the rear leg and may be ordered on the right or left side. A formed steel hinge is welded to the top of the support structure and secured with screws to the underside of the writing surface. Writing surface for standard tablet is 9-1/2" x 20-3/4" x 12-1/2" and oversize tablet is 15-1/2" x 22-1/2" x 14" plywood core of 5/8" thick, 11-ply hardwood surfaced with .030" high-pressure laminate top and plain backer undersurface. Tablet flips up for easy access. Edges are lacquered and sealed.

Four-Leg Cafe Stools

Four-leg models on glides are available in 23-1/2" and 29-1/2" seat heights. Stool-height units are equipped with a reinforcing foot ring made of a 1/2" diameter wire ring, which is open in the back to allow stacking of armless and cantilever arm stools.

Stacking Vinyl, Polyurethane, and Imitation Leather Upholstered Chairs

It is recommended that chairs to be stacked be covered in material other than vinyl, polyurethane, or imitation leather as an impression in the seat may result. KI does not warrant the effects of stacking on stock or C.O.M. vinyl, polyurethane, or imitation leather upholstery.

**Four-Leg Armless Cafe
Stool - 24" or 30"
Seat Height
(SLSNAU)**

**Four-Leg Loop Arm Cafe
Stool - 23" or 29"
Seat Height
(SLSLAP)**

**Armless Wallsaver
Four-Leg Chair
(SLNAU)**
**Four-Leg Wallsaver
Cantilever Arm Chair
(SLCAP)**
**Four-Leg Wallsaver
Loop Arm Chair
(SLLAU)**

| Features | | | | |
|--|--------------------------|--|-------------------|-------------------|
| Stackable | • | | • | • |
| Poly, upholstered seat, or upholstered seat/back | • | | • | • |
| Flex back | • | | • | • |
| General Dimensions | | | | |
| Seat width | 18" | | 18" | 18" |
| Seat depth | 18" | | 18" | 18" |
| Seat height (upholstered add 1") | 24" / 30" | | 17-1/2" | 17-1/2" |
| Overall Dimensions | | | | |
| Width | 25" | | 20-3/4" | 25" |
| Depth | 23-1/2" / 25" | | 22-3/4" | 22-3/4" |
| Height | 39-1/4" / 45-1/4" | | 33" | 33" |
| Arms to floor | 32-1/2" / 38-1/2" | | | 26-1/4" |
| Stacking on Floor | | | | |
| Width | 25-7/8" | | 20-3/4" | 25" |
| Depth | 28" | | 28-1/2" | 28-1/2" |
| Quantity/height | 4 Chairs/48" or 54" High | | 4 Chairs/39" High | 4 Chairs/39" High |

INFORMATION
C.O.M. Testing and Production Requirements

Not all materials are suitable for upholstering this product. A 1 yd. x 54" sample must be submitted and approved prior to acceptance of an order. If the fabric is directional in pattern or weave, the direction must be indicated on the submitted sample, and additional yardage may be requested.

Test samples must be sent to:

KI
 Attn: C.O.M. Specialist
 1687 Westminster Drive - Gate 3
 Green Bay, WI 54302

Fabric Disclaimer

Fabric will be applied as swatched by the fabric manufacturer. Fabric that is required to be applied differently than is swatched will need a Special Cost Request written specifying the direction the fabric is to be applied. The posted standard lead time will apply to the Special Cost Request.

Design

Designed by Giancarlo Piretti and manufactured in the USA by Krueger International, Inc. under license from Pro-Cord S.p.A

INFORMATION
Warranty

Refer to KI Terms & Conditions document or visit ki.com

Stack/Nesting

Strive® General Information



Armless Four-Leg Chair with Casters (SLNAPC)

Four-Leg Cantilever Arm Chair with Casters (SLCAUC)

Four-Leg Loop Arm Chair with Casters (SLLAUC)

Armless Sled Base Chair (SSNAP)

Sled Base Cantilever Arm Chair (SSCAU)

Sled Base Tablet Arm Chair (SSTAPRH)

| Features | | | | | | |
|--|-------------------|-------------------|-------------------|--------------------|--------------------|---------|
| Stackable | • | • | • | • | • | |
| Poly, upholstered seat, or upholstered seat/back | • | • | • | • | • | • |
| Flex back | • | • | • | • | • | • |
| General Dimensions | | | | | | |
| Seat width | 18" | 18" | 18" | 18" | 18" | 18" |
| Seat depth | 18" | 18" | 18" | 18" | 18" | 18" |
| Seat height (upholstered add 1") | 17-3/4" | 17-3/4" | 17-3/4" | 17-3/4" | 17-3/4" | 17-3/4" |
| Tablet to chair back clearance | | | | | | 14" |
| Overall Dimensions | | | | | | |
| Width | 21-1/4" | 25" | 25" | 20-3/4" | 25" | 24" |
| Depth | 22-1/2" | 22-1/2" | 22-1/2" | 21-3/4" | 21-3/4" | 27-3/4" |
| Height | 33-1/4" | 33-1/4" | 33-1/4" | 33-1/4" | 33-1/4" | 33-1/4" |
| Arms to floor | | 26-1/2" | 26-1/2" | | 26-1/2" | 28-1/2" |
| Stacking on Dolly | | | | | | |
| Width | | | | 24" | 25" | |
| Depth - poly | | | | 48" | 48" | |
| Quantity/height - poly | | | | 15 Chairs/64" High | 15 Chairs/64" High | |
| Depth - upholstered | | | | 48" | 48" | |
| Quantity/height - upholstered | | | | 8 Chairs/50" High | 8 Chairs/50" High | |
| Stacking on Floor | | | | | | |
| Width | 20-3/4" | 25" | 25" | 20-3/4" | 25" | |
| Depth | 27-1/2" | 27-1/2" | 27-1/2" | 27-1/2" | 27-1/2" | |
| Quantity/height | 4 Chairs/39" High | 4 Chairs/39" High | 4 Chairs/39" High | 4 Chairs/39" High | 4 Chairs/39" High | |

SPECIFICATIONS

Frame

Legs are 7/8" o.d. x 13-gauge tubular steel. Cross members are 1" o.d. x 14-gauge tubular steel and 7/16" diameter solid steel. All joints are welded. Frames are available in 4-leg or sled base configurations.

Frame Finishes

Baked-on electrostatically-applied 45° gloss epoxy powder coating or bright nickel-chrome plating.

Casters

Four-leg chairs may be ordered with carpet casters or hard floor casters instead of glides (does not apply to cafe stools). Casters are double-wheel, high-impact thermoplastic and are available in black only.

Backrest

Injection molded polypropylene with integral steel cantilever springs. The combination of the slotted polypropylene back and the

spring steel provides a supportive flexing back. Springs are nominal 4.5mm diameter chrome silicon valve spring wire.

Optional Upholstered Seat

Molded urethane foam is attached to an injection molded polypropylene seat board, then upholstered using a draw-string process. The assembled seat pad is attached to the seat by means of hidden fasteners.

Optional Upholstered Back

1/2" thick urethane foam is attached to an injection molded polypropylene back board, then upholstered using a draw-string process. The assembled back pad is attached to the back by means of fasteners which are exposed and are color matched to the polypropylene.

Arms

Optional cantilever arms or loop arms are available. When equipped with arms, the supporting structure is a continuation of the rear leg finished to match the frame

color. The armcaps are injection molded nylon matching the frame finish (except for chrome, hammertone, and metallic finishes which will match poly color. Diamond translucent poly will have light tone armrests; Pewter translucent will have flannel armrests; Bronze translucent will have chocolate armrests). The armcaps are attached to the steel structure by means of screws.

Tablet Arm

Tablet support loop is a continuation of the rear leg and may be ordered on the right or left side. A formed steel hinge is welded to the top of the support structure and secured with screws to the underside of the writing surface. Writing surface for standard tablet is 9-1/2" x 20-3/4" x 12-1/2" and oversize tablet is 15-1/2" x 22-1/2" x 14" plywood core of 5/8" thick, 11-ply hardwood surfaced with .030" high-pressure laminate top and plain backer undersurface. Tablet flips up for easy access. Edges are lacquered and sealed.

Seat and Shroud

Injection molded polypropylene.

Stacking Vinyl, Polyurethane, and Imitation Leather Upholstered Chairs

It is recommended that chairs to be stacked be covered in material other than vinyl, polyurethane, or imitation leather as an impression in the seat may result. KI does not warrant the effects of stacking on stock or C.O.M. vinyl, polyurethane, or imitation leather upholstery.

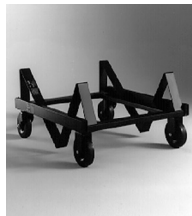
**Transport Dolly
 (SCDA.BL)**
Overall Dimensions

| | |
|--------|---------|
| Width | 24" |
| Depth | 29" |
| Height | 16-1/2" |

INFORMATION
C.O.M. Testing and Production Requirements

Not all materials are suitable for upholstering this product. A 1 yd. x 54" sample must be submitted and approved prior to acceptance of an order. If the fabric is directional in pattern or weave, the direction must be indicated on the submitted sample, and additional yardage may be requested. Test samples must be sent to:

KI
 Attn: C.O.M. Specialist
 1687 Westminster Drive - Gate 3
 Green Bay, WI 54302

Fabric Disclaimer

Fabric will be applied as swatched by the fabric manufacturer. Fabric that is required to be applied differently than is swatched will need a Special Cost Request written specifying the direction the fabric is to be applied. The posted standard lead time will apply to the Special Cost Request.

Design

Designed by Giancarlo Piretti and manufactured in the USA by Krueger International, Inc. under license from Pro-Cord S.p.A

INFORMATION
Warranty

Refer to KI Terms & Conditions document or visit ki.com

Stack/Nesting

Strive® Color Options

Frame Color

| | |
|---------------------------|----|
| Antique Vein | AV |
| Black | BL |
| Blue Grey | GR |
| Bronze Metallic | ZM |
| Cayenne | CY |
| Champagne Metallic | CM |
| Chocolate | CT |
| Chrome | CH |
| Cool Grey | CG |
| Cottonwood | CO |
| Espresso Metallic | EX |
| Flannel | FN |
| Grass Green | GN |
| Light Tone | LG |
| Mardi Gras | MG |
| Misty Brown | MY |
| Nemo | NE |
| Nickel Vein | NK |
| Nordic | ND |
| Poppy Red | PR |
| Purple Haze | PH |
| Rubber Ducky | RK |
| Sand | SA |
| Sky Blue | SK |
| Splash | SH |
| Starlight Silver Metallic | SX |
| Surf's Up | SP |
| Ultra Blue | UB |
| Warm Grey | WG |
| Wet Sand | WS |
| Zesty Lime | ZL |

Armcaps and glides match the frame color with the following exceptions:

-When frame color is chrome, metallic, or hammertone, the armcaps and glides will match poly color.

-When frame color is chrome, metallic, or hammertone, and the poly color is translucent diamond, the armcaps will be light tone.

-When frame color is chrome, metallic, or hammertone, and the poly color is translucent pewter, the armcaps will be flannel.

-When frame color is chrome, metallic, or hammertone, and the poly color is translucent bronze, the armcaps will be chocolate.

Casters for four-leg chairs are always black.

Seat and Back Color - Polypropylene Non Flame-Retardant

| | |
|--------------|-----|
| Black | PBL |
| Blue Grey | PGR |
| Cayenne | PCY |
| Chocolate | PCT |
| Cool Grey | PCG |
| Cottonwood | PCO |
| Flannel | PFN |
| Grass Green | PGN |
| Light Tone | PLG |
| Mardi Gras | PMG |
| Misty Brown | PMY |
| Nemo | PNE |
| Nordic | PND |
| Poppy Red | PPR |
| Purple Haze | PPH |
| Rubber Ducky | PRK |
| Sand | PSA |
| Sky Blue | PSK |
| Splash | PSH |
| Surf's Up | PSP |
| Ultra Blue | PUB |
| Warm Grey | PWG |
| Wet Sand | PWS |
| Zesty Lime | PZL |

Seat and Back Color - Polypropylene Flame-Retardant

| | |
|-------|-----|
| Black | PBL |
|-------|-----|

The above seating product can be manufactured using the appropriate flame-retardant materials for compliance to California Technical Bulletin 133.

TRANSLUCENT colors are available on the upholstered seat models only.

Tablet Arm Color - Laminate

| | |
|--------------------|-----|
| Biltmore Cherry | LBT |
| Black | LBK |
| Brighton Walnut | LBW |
| Canyon Zephyr | LCA |
| Castle Oak | LCO |
| Casual Linen | LCU |
| Cherry Storm | LCX |
| Classic Linen | LCI |
| Cloud Zephyr | LCL |
| Cocobala | LCC |
| Coffee Bean | LCB |
| Crisp Linen | LRI |
| Desert Zephyr | LDZ |
| Dove Grey | LDG |
| Fired Steel | LIL |
| Flax Linen | LXF |
| Florence Walnut | LFC |
| Forged Steel | LOL |
| Frosty White | LFW |
| Graphite Nebula | LGN |
| Grey | LGE |
| High Rise | LHE |
| Hollyberry | LHY |
| Irish Linen | LIH |
| Island | LID |
| Italian Silver Ash | LIT |
| Kensington Maple | LKM |
| Lapis Blue | LLB |
| Markerboard White | LMK |
| Misted Zephyr | LMR |
| Monticello Maple | LMT |
| Nickel Evolv | LNV |
| North Sea | LNA |
| Ocean | LON |
| Orange Grove | LOE |
| Pearl Bisque | LPB |
| Pearl Silver | LPS |
| Pressed Linen | LPR |
| River Cherry | LRY |
| Rugged Linen | LRG |
| Satin Stainless | LSS |
| Shadow Zephyr | LSR |
| Silicon evolv | LSV |
| Sterling Ash | LAZ |
| Tailored Linen | LTL |
| Titanium evolv | LTV |
| White Nebula | LWL |
| White Sand | LWN |
| Windsor Mahogany | LWY |

Finish Cards

View color swatches for items listed within this document.

Paints

Wood/Veneer

Molded Edges

Hard Plastics

Plastics/Poly

Laminates



Edge Styles

Glass



Stack/Nesting

Strive® Chairs

| MODEL | Features | MODEL NUMBER | | | | | | |
|---|-------------------------|--------------|--------------------------|--------------------------|--------------------------|--------------------------|--------------------------|--------------------------|
| | | Basic Model | Frame Color | Seat & Back Color | Caster Type | Glide Option | Fire Code | Upholstery Color |
|  <p>Four-Leg Armless Chair</p> <ul style="list-style-type: none"> • Flex back • Stacking | Polypropylene | SLNAP | <input type="checkbox"/> | <input type="checkbox"/> | | <input type="checkbox"/> | <input type="checkbox"/> | |
| | Upholstered Seat | SLNAU | <input type="checkbox"/> | <input type="checkbox"/> | | <input type="checkbox"/> | <input type="checkbox"/> | <input type="checkbox"/> |
| | Upholstered Seat/Back | SLNAUB | <input type="checkbox"/> | <input type="checkbox"/> | | <input type="checkbox"/> | <input type="checkbox"/> | <input type="checkbox"/> |
| SLP | | | | | | | | |
| SLU | | | | | | | | |
| SLUB | | | | | | | | |
|  <p>Four-Leg Armless Chair with Casters</p> <ul style="list-style-type: none"> • Flex back • Stacking. Caution should be exercised to prevent casters from marring components such as frames, fabric, etc., and to prevent casters from becoming "hung up" underneath the seat of the chair • Stacking on dollies is NOT recommended | Polypropylene, Casters | SLNAPC | <input type="checkbox"/> | <input type="checkbox"/> | <input type="checkbox"/> | | <input type="checkbox"/> | |
| | Uph. Seat, Casters | SLNAUC | <input type="checkbox"/> | <input type="checkbox"/> | <input type="checkbox"/> | | <input type="checkbox"/> | <input type="checkbox"/> |
| | Uph. Seat/Back, Casters | SLNAUBC | <input type="checkbox"/> | <input type="checkbox"/> | <input type="checkbox"/> | | <input type="checkbox"/> | <input type="checkbox"/> |
| SLP | | | | | | | | |
| SLU | | | | | | | | |
| SLUB | | | | | | | | |

A **B** **C** **D** **E** **F** **G**

HOW TO ORDER

Indicate the following information on order form:

1. Quantity of each item.
2. Model number, including options. See "How To Build a Model Number".
3. Any special service required.

Note: • The indicates that a choice is required.

- The absence of the indicates that no choice is required.
- Alpha-numeric characters in place of indicate that no other alternatives are available.

HOW TO BUILD A MODEL NUMBER

- A** Select basic model.
- B** Select frame color.
Refer to the **Product Color Options** page in this price list.
- C** Select poly seat and back color.
Refer to the **Product Color Options** page in this price list.
- D** Select casters.

| | |
|----------|-----------------------------------|
| C | - Carpet casters (black only) |
| S | - Hard floor casters (black only) |
- E** Select glide option.

| | |
|----------|------------------|
| F | - Felt Glides |
| P | - Plastic glides |
| S | - Steel glides |
- F** Select fire code.

| | |
|------------|-----------------------------|
| NFR | - Compliance to TB 117-2013 |
| FR | - Compliance to TB 133 |

G Select upholstery grade/color.
Refer to ki.com/fabrics



| Approx. Packaged Weight | Delivered Pricing Unupholstered | Delivered Pricing Fabric Grade 1 & C.O.M. | Delivered Pricing Fabric Grade 2 | Delivered Pricing Fabric Grade 3 | Delivered Pricing C.O.V. | Delivered Pricing Vinyl Group 2V | Delivered Pricing Pallas Fabric Group P0 | Delivered Pricing Pallas Fabric Group P1 | Delivered Pricing Pallas Fabric Group P2 | Delivered Pricing Pallas Fabric Group P3 | Delivered Pricing Pallas Fabric Group P4 |
|-------------------------|---------------------------------|---|----------------------------------|----------------------------------|--------------------------|----------------------------------|--|--|--|--|--|
| 20.0# | \$ 206 | | | | | | | | | | |
| 23.0# | N/A | 271 | 302 | 315 | 271 | 315 | 312 | 353 | 374 | 397 | 417 |
| 23.0# | N/A | 329 | 359 | 371 | 329 | 371 | 370 | 410 | 431 | 454 | 472 |
| 26.0# | \$ 245 | | | | | | | | | | |
| 29.0# | N/A | 311 | 341 | 356 | 311 | 356 | 356 | 395 | 417 | 439 | 458 |
| 29.0# | N/A | 368 | 397 | 412 | 368 | 412 | 411 | 451 | 472 | 493 | 515 |

UPHOLSTERY INFORMATION

C.O.M. Upholstery

C.O.M. requirement for 10 chairs or less with upholstered seat or upholstered seat and back is 3/4 yard per chair of 54" wide nondirectional fabric. For orders of 11 or more with upholstered seat and back and for complete information on ordering C.O.M. see "Ordering C.O.M., C.O.V. and C.O.L." section.

OPTIONS

California TB133 Fire Safety Code

The above seating products can be manufactured using the appropriate flame-retardant materials for compliance to California Technical Bulletin 133.

Model=Polypropylene
 Added List Price=\$10

Model=Upholstered Seat
 Added List Price=\$73

Model=Upholstered Seat and Back
 Added List Price=\$104

SPECIAL SERVICES

Special Carton Marking

With specially marked information N/C



Shipping

Ships **assembled, FOB Green Bay, WI 54302, freight prepaid.** Freight class 125.

Specifications and prices are subject to change without prior notice.

Stack/Nesting

Strive® Chairs

| Features | MODEL NUMBER | | | | | | | | Approx. Packaged Weight | |
|---|-------------------------|-------------|--------------------------|--------------------------|--------------------------|--------------------------|--------------------------|--------------------------|--------------------------|----------|
| | Basic Model | Frame Color | Seat & Back Color | Top Stitch Color | Caster Type | Glide Option | Fire Code | Upholstery Color | | |
|  <p>SLTS SLBTS</p> <p>Four-Leg Armless Chair with Top Stitch on Seat</p> <ul style="list-style-type: none"> • Flex back • Stacking | Upholstered Seat | SLNATSU | <input type="checkbox"/> | <input type="checkbox"/> | <input type="checkbox"/> | <input type="checkbox"/> | <input type="checkbox"/> | <input type="checkbox"/> | 23.0# | |
| | Upholstered Seat/Back | SLNATSUB | <input type="checkbox"/> | <input type="checkbox"/> | <input type="checkbox"/> | <input type="checkbox"/> | <input type="checkbox"/> | <input type="checkbox"/> | <input type="checkbox"/> | 23.0# |
|  <p>SLTS SLBTS</p> <p>Four-Leg Armless Chair with Casters with Top Stitch on Seat</p> <ul style="list-style-type: none"> • Flex back • Stacking. Caution should be exercised to prevent casters from marring components such as frames, fabric, etc., and to prevent casters from becoming "hung up" underneath the seat of the chair • Stacking on dollies is NOT recommended | Uph. Seat, Casters | SLNATSUC | <input type="checkbox"/> | <input type="checkbox"/> | <input type="checkbox"/> | <input type="checkbox"/> | <input type="checkbox"/> | <input type="checkbox"/> | 29.0# | |
| | Uph. Seat/Back, Casters | SLNATSUBC | <input type="checkbox"/> | <input type="checkbox"/> | <input type="checkbox"/> | <input type="checkbox"/> | <input type="checkbox"/> | <input type="checkbox"/> | <input type="checkbox"/> | 29.0# |
| | | | A | B | C | D | E | F | G | H |

HOW TO ORDER

Indicate the following information on order form:

1. Quantity of each item.
2. Model number, including options. See "How To Build a Model Number".
3. Any special service required.

Note: • The indicates that a choice is required.

- The absence of the indicates that no choice is required.
- Alpha-numeric characters in place of indicate that no other alternatives are available.

HOW TO BUILD A MODEL NUMBER

A Select basic model.

B Select frame color.
Refer to the **Product Color Options** page in this price list.

C Select poly seat and back color.
Refer to the **Product Color Options** page in this price list.

D Select top stitch color.
BLTS - Black
WHTS - White

E Select casters.
C - Carpet casters (black only)
S - Hard floor casters (black only)

F Select glide option.
F - Felt Glides
P - Plastic glides
S - Steel glides

G Select fire code.

FR - Compliance to TB 133
NFR - Compliance to TB 117-2013

H Select upholstery grade/color.
Refer to ki.com/fabrics



Delivered
Pricing
Pallas Fabric
Group P1

\$ 397
454

\$ 439
493

UPHOLSTERY INFORMATION

C.O.M. Upholstery

C.O.M. requirement for 10 chairs or less with upholstered seat or upholstered seat and back is 3/4 yard per chair of 54" wide nondirectional fabric. For orders of 11 or more with upholstered seat and back and for complete information on ordering C.O.M. see "Ordering C.O.M., C.O.V. and C.O.L." section.

OPTIONS

California TB133 Fire Safety Code

The above seating products can be manufactured using the appropriate flame-retardant materials for compliance to California Technical Bulletin 133.

Model=Polypropylene
Added List Price=\$10

Model=Upholstered Seat
Added List Price=\$73

Model=Upholstered Seat and Back
Added List Price=\$104

SPECIAL SERVICES

Special Carton Marking

With specially marked information N/C



Shipping

Ships **assembled, FOB Green Bay, WI 54302, freight prepaid.** Freight class 125.

Specifications and prices are subject to change without prior notice.

Stack/Nesting

Strive® Chairs

| MODEL | Features | MODEL NUMBER | | | | | | | |
|---|---|------------------------|--------------------------|--------------------------|--------------------------|--------------------------|--------------------------|--------------------------|--------------------------|
| | | Basic Model | Frame Color | Seat & Back Color | Caster Type | Glide Option | Fire Code | Upholstery Color | |
|  <p>SLP SLU SLUB</p> | Four-Leg Cantilever Armchair • Flex back • Stacking | Polypropylene | SLCAP | <input type="checkbox"/> | <input type="checkbox"/> | <input type="checkbox"/> | <input type="checkbox"/> | <input type="checkbox"/> | <input type="checkbox"/> |
| | Upholstered Seat | SLCAU | <input type="checkbox"/> | <input type="checkbox"/> | <input type="checkbox"/> | <input type="checkbox"/> | <input type="checkbox"/> | <input type="checkbox"/> | <input type="checkbox"/> |
| | Upholstered Seat/Back | SLCAUB | <input type="checkbox"/> | <input type="checkbox"/> | <input type="checkbox"/> | <input type="checkbox"/> | <input type="checkbox"/> | <input type="checkbox"/> | <input type="checkbox"/> |
| | | | | | | | | | |
|  <p>SLP SLU SLUB</p> | Four-Leg Cantilever Armchair with Casters • Flex back • Stacking. Caution should be exercised to prevent casters from marring components such as frames, fabric, etc., and to prevent casters from becoming "hung up" underneath the seat of the chair • Stacking on dollies is NOT recommended | Polypropylene, Casters | SLCAPC | <input type="checkbox"/> | <input type="checkbox"/> | <input type="checkbox"/> | <input type="checkbox"/> | <input type="checkbox"/> | <input type="checkbox"/> |
| | Uph. Seat, Casters | SLCAUC | <input type="checkbox"/> | <input type="checkbox"/> | <input type="checkbox"/> | <input type="checkbox"/> | <input type="checkbox"/> | <input type="checkbox"/> | <input type="checkbox"/> |
| | Uph. Seat/Back, Casters | SLCAUBC | <input type="checkbox"/> | <input type="checkbox"/> | <input type="checkbox"/> | <input type="checkbox"/> | <input type="checkbox"/> | <input type="checkbox"/> | <input type="checkbox"/> |
| | | | | | | | | | |

A **B** **C** **D** **E** **F** **G**

HOW TO ORDER

Indicate the following information on order form:

- Quantity of each item.
- Model number, including options. See "How To Build a Model Number".
- Any special service required.

Note: • The indicates that a choice is required.

- The absence of the indicates that no choice is required.
- Alpha-numeric characters in place of indicate that no other alternatives are available.

HOW TO BUILD A MODEL NUMBER

G Select upholstery grade/color. Refer to ki.com/fabrics

A Select basic model.

B Select frame color. Refer to the **Product Color Options** page in this price list.

C Select poly seat and back color. Refer to the **Product Color Options** page in this price list.

D Select casters.
C _____ - Carpet casters (black only)
S _____ - Hard floor casters (black only)

E Select glide option.
F _____ - Felt Glides
P _____ - Plastic glides
S _____ - Steel glides

F Select fire code.
FR _____ - Compliance to TB 133
NFR _____ - Compliance to TB 117-2013



| Approx. Packaged Weight | Delivered Pricing Unupholstered | Delivered Pricing Fabric Grade 1 & C.O.M. | Delivered Pricing Fabric Grade 2 | Delivered Pricing Fabric Grade 3 | Delivered Pricing C.O.V. | Delivered Pricing Vinyl Group 2V | Delivered Pricing Pallas Fabric Group P0 | Delivered Pricing Pallas Fabric Group P1 | Delivered Pricing Pallas Fabric Group P2 | Delivered Pricing Pallas Fabric Group P3 | Delivered Pricing Pallas Fabric Group P4 |
|-------------------------|---------------------------------|---|----------------------------------|----------------------------------|--------------------------|----------------------------------|--|--|--|--|--|
| 23.0# | \$ 268 | | | | | | | | | | |
| 26.0# | N/A | 334 | 365 | 375 | 334 | 375 | 375 | 416 | 437 | 459 | 479 |
| 26.0# | N/A | 390 | 420 | 432 | 390 | 432 | 432 | 471 | 492 | 516 | 534 |
| 28.0# | \$ 307 | | | | | | | | | | |
| 31.0# | N/A | 373 | 404 | 418 | 373 | 418 | 417 | 457 | 479 | 500 | 520 |
| 31.0# | N/A | 430 | 460 | 473 | 430 | 473 | 471 | 512 | 534 | 557 | 576 |

UPHOLSTERY INFORMATION

C.O.M. Upholstery

C.O.M. requirement for 10 chairs or less with upholstered seat or upholstered seat and back is 3/4 yard per chair of 54" wide nondirectional fabric. For orders of 11 or more with upholstered seat and back and for complete information on ordering C.O.M. see "Ordering C.O.M., C.O.V. and C.O.L." section.

OPTIONS

California TB133 Fire Safety Code

The above seating products can be manufactured using the appropriate flame-retardant materials for compliance to California Technical Bulletin 133.

Model=Polypropylene
 Added List Price=\$10

Model=Upholstered Seat
 Added List Price=\$73

Model=Upholstered Seat and Back
 Added List Price=\$104

SPECIAL SERVICES

Special Carton Marking

With specially marked information N/C



Shipping

Ships **assembled, FOB Green Bay, WI 54302, freight prepaid.** Freight class 125.

Specifications and prices are subject to change without prior notice.

Stack/Nesting

Strive® Chairs

| Features | MODEL NUMBER | | | | | | | | Approx. Packaged Weight | |
|---|-------------------------|-------------|--------------------------|--------------------------|--------------------------|--------------------------|--------------------------|--------------------------|--------------------------|----------|
| | Basic Model | Frame Color | Seat & Back Color | Top Stitch Color | Caster Type | Glide Option | Fire Code | Upholstery Color | | |
|  <p>SLTS SLBTS</p> <p>Four-Leg Cantilever Armchair with Top Stitch on Seat</p> <ul style="list-style-type: none"> • Flex back • Stacking | Upholstered Seat | SLCATSU | <input type="checkbox"/> | <input type="checkbox"/> | <input type="checkbox"/> | <input type="checkbox"/> | <input type="checkbox"/> | <input type="checkbox"/> | 26.0# | |
| | Upholstered Seat/Back | SLCATSUB | <input type="checkbox"/> | <input type="checkbox"/> | <input type="checkbox"/> | <input type="checkbox"/> | <input type="checkbox"/> | <input type="checkbox"/> | <input type="checkbox"/> | 26.0# |
|  <p>SLTS SLBTS</p> <p>Four-Leg Cantilever Armchair with Casters with Top Stitch on Seat</p> <ul style="list-style-type: none"> • Flex back • Stacking. Caution should be exercised to prevent casters from marring components such as frames, fabric, etc., and to prevent casters from becoming "hung up" underneath the seat of the chair • Stacking on dollies is NOT recommended | Uph. Seat, Casters | SLCATSUC | <input type="checkbox"/> | <input type="checkbox"/> | <input type="checkbox"/> | <input type="checkbox"/> | <input type="checkbox"/> | <input type="checkbox"/> | 31.0# | |
| | Uph. Seat/Back, Casters | SLCATSUBC | <input type="checkbox"/> | <input type="checkbox"/> | <input type="checkbox"/> | <input type="checkbox"/> | <input type="checkbox"/> | <input type="checkbox"/> | <input type="checkbox"/> | 31.0# |
| | | | A | B | C | D | E | F | G | H |

HOW TO ORDER

Indicate the following information on order form:

1. Quantity of each item.
2. Model number, including options. See "How To Build a Model Number".
3. Any special service required.

Note: • The indicates that a choice is required.

- The absence of the indicates that no choice is required.
- Alpha-numeric characters in place of indicate that no other alternatives are available.

HOW TO BUILD A MODEL NUMBER

A Select basic model.

B Select frame color.
Refer to the **Product Color Options** page in this price list.

C Select poly seat and back color.
Refer to the **Product Color Options** page in this price list.

D Select top stitch color.
BLTS - Black
WHTS - White

E Select casters.
C - Carpet casters (black only)
S - Hard floor casters (black only)

F Select glide option.
F - Felt Glides
P - Plastic glides
S - Steel glides

G Select fire code.

NFR - Compliance to TB 117-2013
FR - Compliance to TB 133

H Select upholstery grade/color.
Refer to ki.com/fabrics



Delivered
Pricing
Pallas Fabric
Group P1

\$ 460
517

\$ 499
556

UPHOLSTERY INFORMATION

C.O.M. Upholstery

C.O.M. requirement for 10 chairs or less with upholstered seat or upholstered seat and back is 3/4 yard per chair of 54" wide nondirectional fabric. For orders of 11 or more with upholstered seat and back and for complete information on ordering C.O.M. see "Ordering C.O.M., C.O.V. and C.O.L." section.

OPTIONS

California TB133 Fire Safety Code

The above seating products can be manufactured using the appropriate flame-retardant materials for compliance to California Technical Bulletin 133.

Model=Polypropylene
Added List Price=\$10

Model=Upholstered Seat
Added List Price=\$73

Model=Upholstered Seat and Back
Added List Price=\$104

SPECIAL SERVICES

Special Carton Marking

With specially marked information N/C



Shipping

Ships **assembled, FOB Green Bay, WI 54302, freight prepaid.** Freight class 125.

Specifications and prices are subject to change without prior notice.

Stack/Nesting

Strive® Chairs

| MODEL | Features | MODEL NUMBER | | | | | | | |
|--|---------------------------|--------------|---|---|--------------------------|--------------------------|--|---|----------|
| | | Basic Model | Frame Color | Seat & Back Color | Caster Type | Glide Option | Fire Code | Upholstery Color | |
|  <p>Four-Leg Loop Arm Chair</p> <ul style="list-style-type: none"> Flex back Stacking | Polypropylene | SLLAP | <input type="checkbox"/> <input type="checkbox"/> | <input type="checkbox"/> <input type="checkbox"/> <input type="checkbox"/> <input type="checkbox"/> | | <input type="checkbox"/> | <input type="checkbox"/> <input type="checkbox"/> <input type="checkbox"/> | | |
| | Upholstered Seat | SLLAU | <input type="checkbox"/> <input type="checkbox"/> | <input type="checkbox"/> <input type="checkbox"/> <input type="checkbox"/> <input type="checkbox"/> | | <input type="checkbox"/> | <input type="checkbox"/> <input type="checkbox"/> <input type="checkbox"/> | <input type="checkbox"/> <input type="checkbox"/> <input type="checkbox"/> <input type="checkbox"/> <input type="checkbox"/> <input type="checkbox"/> | |
| | Upholstered Seat/Back | SLLAUB | <input type="checkbox"/> <input type="checkbox"/> | <input type="checkbox"/> <input type="checkbox"/> <input type="checkbox"/> <input type="checkbox"/> | | <input type="checkbox"/> | <input type="checkbox"/> <input type="checkbox"/> <input type="checkbox"/> | <input type="checkbox"/> <input type="checkbox"/> <input type="checkbox"/> <input type="checkbox"/> <input type="checkbox"/> <input type="checkbox"/> | |
| SLP SLU SLUB | | | | | | | | | |
|  <p>Four-Leg Loop Arm Chair with Casters</p> <ul style="list-style-type: none"> Flex back Stacking. Caution should be exercised to prevent casters from marring components such as frames, fabric, etc., and to prevent casters from becoming "hung up" underneath the seat of the chair below Stacking on dollies is NOT recommended | Polypropylene, Casters | SLLAPC | <input type="checkbox"/> <input type="checkbox"/> | <input type="checkbox"/> <input type="checkbox"/> <input type="checkbox"/> <input type="checkbox"/> | <input type="checkbox"/> | | <input type="checkbox"/> <input type="checkbox"/> <input type="checkbox"/> | | |
| | Upholstered Seat, Casters | SLLAUC | <input type="checkbox"/> <input type="checkbox"/> | <input type="checkbox"/> <input type="checkbox"/> <input type="checkbox"/> <input type="checkbox"/> | <input type="checkbox"/> | | <input type="checkbox"/> <input type="checkbox"/> <input type="checkbox"/> | <input type="checkbox"/> <input type="checkbox"/> <input type="checkbox"/> <input type="checkbox"/> <input type="checkbox"/> <input type="checkbox"/> | |
| | Uph. Seat/Back, Casters | SLLAUBC | <input type="checkbox"/> <input type="checkbox"/> | <input type="checkbox"/> <input type="checkbox"/> <input type="checkbox"/> <input type="checkbox"/> | <input type="checkbox"/> | | <input type="checkbox"/> <input type="checkbox"/> <input type="checkbox"/> | <input type="checkbox"/> <input type="checkbox"/> <input type="checkbox"/> <input type="checkbox"/> <input type="checkbox"/> <input type="checkbox"/> | |
| SLP SLU SLUB | | | | | | | | | |
| | | | A | B | C | D | E | F | G |

HOW TO ORDER

Indicate the following information on order form:

- Quantity of each item.
- Model number, including options. See "How To Build a Model Number".
- Any special service required.

Note: • The indicates that a choice is required.

- The absence of the indicates that no choice is required.
- Alpha-numeric characters in place of indicate that no other alternatives are available.

HOW TO BUILD A MODEL NUMBER

- A** Select basic model.
- B** Select frame color.
Refer to the **Product Color Options** page in this price list.
- C** Select poly seat and back color.
Refer to the **Product Color Options** page in this price list.
- D** Select casters.
 - C** _____ - Carpet casters (black only)
 - S** _____ - Hard floor casters (black only)
- E** Select glide option.
 - F** _____ - Felt Glides
 - P** _____ - Plastic glides
 - S** _____ - Steel glides
- F** Select fire code.
 - NFR** _____ - Compliance to TB 117-2013
 - FR** _____ - Compliance to TB 133

G Select upholstery grade/color.
Refer to ki.com/fabrics



| Approx. Packaged Weight | Delivered Pricing Unupholstered | Delivered Pricing Fabric Grade 1 & C.O.M. | Delivered Pricing Fabric Grade 2 | Delivered Pricing Fabric Grade 3 | Delivered Pricing C.O.V. | Delivered Pricing Vinyl Group 2V | Delivered Pricing Pallas Fabric Group P0 | Delivered Pricing Pallas Fabric Group P1 | Delivered Pricing Pallas Fabric Group P2 | Delivered Pricing Pallas Fabric Group P3 | Delivered Pricing Pallas Fabric Group P4 |
|-------------------------|---------------------------------|---|----------------------------------|----------------------------------|--------------------------|----------------------------------|--|--|--|--|--|
| 25.0# | \$ 281 | | | | | | | | | | |
| 27.0# | N/A | 345 | 375 | 391 | 345 | 391 | 390 | 430 | 451 | 471 | 491 |
| 27.0# | N/A | 402 | 432 | 445 | 402 | 445 | 445 | 486 | 506 | 527 | 547 |
| 30.0# | \$ 321 | | | | | | | | | | |
| 32.0# | N/A | 387 | 418 | 432 | 387 | 432 | 430 | 469 | 491 | 516 | 531 |
| 32.0# | N/A | 443 | 473 | 488 | 443 | 488 | 486 | 525 | 547 | 570 | 588 |

UPHOLSTERY INFORMATION

C.O.M. Upholstery

C.O.M. requirement for 10 chairs or less with upholstered seat or upholstered seat and back is 3/4 yard per chair of 54" wide nondirectional fabric. For orders of 11 or more with upholstered seat and back and for complete information on ordering C.O.M. see "Ordering C.O.M., C.O.V. and C.O.L." section.

OPTIONS

California TB133 Fire Safety Code

The above seating products can be manufactured using the appropriate flame-retardant materials for compliance to California Technical Bulletin 133.

Model=Polypropylene
 Added List Price=\$10

Model=Upholstered Seat
 Added List Price=\$73

Model=Upholstered Seat and Back
 Added List Price=\$104

SPECIAL SERVICES

Special Carton Marking

With specially marked information N/C



Shipping

Ships **assembled, FOB Green Bay, WI 54302, freight prepaid.** Freight class 125.

Specifications and prices are subject to change without prior notice.

Stack/Nesting

Strive® Chairs

| | Features | MODEL NUMBER | | | | | | | | Approx. Packaged Weight |
|---|-------------------------|--------------|--------------------------|--------------------------|--------------------------|--------------------------|--------------------------|--------------------------|--------------------------|-------------------------|
| | | Basic Model | Frame Color | Seat & Back Color | Top Stitch Color | Caster Type | Glide Option | Fire Code | Upholstery Color | |
|  <p>SLTS SLBTS Four-Leg Loop Arm Chair with Top Stitch on Seat • Flex back • Stacking</p> | Upholstered Seat | SLLATSU | <input type="checkbox"/> | <input type="checkbox"/> | <input type="checkbox"/> | | <input type="checkbox"/> | <input type="checkbox"/> | <input type="checkbox"/> | 27.0# |
| | Upholstered Seat/Back | SLLATSUB | <input type="checkbox"/> | <input type="checkbox"/> | <input type="checkbox"/> | | <input type="checkbox"/> | <input type="checkbox"/> | <input type="checkbox"/> | 27.0# |
|  <p>SLTS SLBTS Four-Leg Loop Arm Chair with Casters with Top Stitch on Seat • Flex back • Stacking. Caution should be exercised to prevent casters from marring components such as frames, fabric, etc., and to prevent casters from becoming "hung up" underneath the seat of the chair below • Stacking on dollies is NOT recommended</p> | Uph. Seat, Casters | SLLATSUC | <input type="checkbox"/> | <input type="checkbox"/> | <input type="checkbox"/> | <input type="checkbox"/> | | <input type="checkbox"/> | <input type="checkbox"/> | 32.0# |
| | Uph. Seat/Back, Casters | SLLATSUBC | <input type="checkbox"/> | <input type="checkbox"/> | <input type="checkbox"/> | <input type="checkbox"/> | | <input type="checkbox"/> | <input type="checkbox"/> | 32.0# |
| | | A | B | C | D | E | F | G | H | |

HOW TO ORDER

Indicate the following information on order form:

1. Quantity of each item.
2. Model number, including options. See "How To Build a Model Number".
3. Any special service required.

Note: • The indicates that a choice is required.

- The absence of the indicates that no choice is required.
- Alpha-numeric characters in place of indicate that no other alternatives are available.

HOW TO BUILD A MODEL NUMBER

- A** Select basic model.
- B** Select frame color.
Refer to the **Product Color Options** page in this price list.
- C** Select poly seat and back color.
Refer to the **Product Color Options** page in this price list.
- D** Select top stitch color.
 BLTS - Black
 WHTS - White
- E** Select casters.
 C - Carpet casters (black only)
 S - Hard floor casters (black only)
- F** Select glide option.
 F - Felt Glides
 P - Plastic glides
 S - Steel glides

- G** Select fire code.
 NFR - Compliance to TB 117-2013
 FR - Compliance to TB 133

- H** Select upholstery grade/color.
Refer to ki.com/fabrics



Delivered
Pricing
Pallas Fabric
Group P1

\$ 472
528

\$ 515
568

UPHOLSTERY INFORMATION

C.O.M. Upholstery

C.O.M. requirement for 10 chairs or less with upholstered seat or upholstered seat and back is 3/4 yard per chair of 54" wide nondirectional fabric. For orders of 11 or more with upholstered seat and back and for complete information on ordering C.O.M. see "Ordering C.O.M., C.O.V. and C.O.L." section.

OPTIONS

California TB133 Fire Safety Code

The above seating products can be manufactured using the appropriate flame-retardant materials for compliance to California Technical Bulletin 133.

Model=Polypropylene
Added List Price=\$10

Model=Upholstered Seat
Added List Price=\$73

Model=Upholstered Seat and Back
Added List Price=\$104

SPECIAL SERVICES

Special Carton Marking

With specially marked information N/C



Shipping

Ships **assembled, FOB Green Bay, WI 54302, freight prepaid.** Freight class 125.

Specifications and prices are subject to change without prior notice.

Stack/Nesting

Strive® Chairs

| | MODEL | Features | MODEL NUMBER | | | | | | |
|---|---|----------------------------|--------------|--------------------------|--------------------------|--------------------------|--------------------------|--------------------------|--------------------------|
| | | | Basic Model | Frame Color | Seat & Back Color | Glide Option | Tablet Arm Color | Fire Code | Upholstery Color |
|  <p>SLP SLU SLUB</p> | Four-Leg Tablet Arm Chair • Flex back • NONSTACKING | Polypropylene, Left Hand | SLTAPLH | <input type="checkbox"/> | <input type="checkbox"/> | <input type="checkbox"/> | <input type="checkbox"/> | <input type="checkbox"/> | |
| | | Polypropylene, Right Hand | SLTAPRH | <input type="checkbox"/> | <input type="checkbox"/> | <input type="checkbox"/> | <input type="checkbox"/> | <input type="checkbox"/> | |
| | | Uph. Seat, Left Hand | SLTAULH | <input type="checkbox"/> | <input type="checkbox"/> | <input type="checkbox"/> | <input type="checkbox"/> | <input type="checkbox"/> | <input type="checkbox"/> |
| | | Uph. Seat, Right Hand | SLTAURH | <input type="checkbox"/> | <input type="checkbox"/> | <input type="checkbox"/> | <input type="checkbox"/> | <input type="checkbox"/> | <input type="checkbox"/> |
| | | Uph. Seat/Back, Left Hand | SLTAUBLH | <input type="checkbox"/> | <input type="checkbox"/> | <input type="checkbox"/> | <input type="checkbox"/> | <input type="checkbox"/> | <input type="checkbox"/> |
| | | Uph. Seat/Back, Right Hand | SLTAUBRH | <input type="checkbox"/> | <input type="checkbox"/> | <input type="checkbox"/> | <input type="checkbox"/> | <input type="checkbox"/> | <input type="checkbox"/> |
| | | | | | | | | | |
|  <p>SLP SLU SLUB</p> | Four-Leg Oversize Tablet Arm Chair • Oversized tablet • Flex back • NONSTACKING | Polypropylene, Left Hand | SLOVTAPLH | <input type="checkbox"/> | <input type="checkbox"/> | <input type="checkbox"/> | <input type="checkbox"/> | <input type="checkbox"/> | |
| | | Polypropylene, Right Hand | SLOVTAPRH | <input type="checkbox"/> | <input type="checkbox"/> | <input type="checkbox"/> | <input type="checkbox"/> | <input type="checkbox"/> | |
| | | Uph. Seat, Left Hand | SLOVTAULH | <input type="checkbox"/> | <input type="checkbox"/> | <input type="checkbox"/> | <input type="checkbox"/> | <input type="checkbox"/> | <input type="checkbox"/> |
| | | Uph. Seat, Right Hand | SLOVTAURH | <input type="checkbox"/> | <input type="checkbox"/> | <input type="checkbox"/> | <input type="checkbox"/> | <input type="checkbox"/> | <input type="checkbox"/> |
| | | Uph. Seat/Back, Left Hand | SLOVTAUBLH | <input type="checkbox"/> | <input type="checkbox"/> | <input type="checkbox"/> | <input type="checkbox"/> | <input type="checkbox"/> | <input type="checkbox"/> |
| | | Uph. Seat/Back, Right Hand | SLOVTAUBRH | <input type="checkbox"/> | <input type="checkbox"/> | <input type="checkbox"/> | <input type="checkbox"/> | <input type="checkbox"/> | <input type="checkbox"/> |
| | | | | | | | | | |
| | | | A | B | C | D | E | F | G |

HOW TO ORDER

Indicate the following information on order form:

- Quantity of each item.
- Model number, including options. See "How To Build a Model Number".
- Any special service required.

Note: • The indicates that a choice is required.

- The absence of the indicates that no choice is required.
- Alpha-numeric characters in place of indicate that no other alternatives are available.

HOW TO BUILD A MODEL NUMBER

G Select upholstery grade/color. Refer to ki.com/fabrics

A Select basic model.

B Select frame color. Refer to the **Product Color Options** page in this price list.

C Select poly seat and back color. Refer to the **Product Color Options** page in this price list.

D Select glide option.
F - Felt Glides
P - Plastic glides
S - Steel glides

E Select tablet arm color. Refer to the **Product Color Options** page in this price list.

F Select fire code.
FR - Compliance to TB 133
NFR - Compliance to TB 117-2013



| Approx. Packaged Weight | Delivered Pricing Unupholstered | Delivered Pricing Fabric Grade 1 & C.O.M. | Delivered Pricing Fabric Grade 2 | Delivered Pricing Fabric Grade 3 | Delivered Pricing C.O.V. | Delivered Pricing Vinyl Group 2V | Delivered Pricing Pallas Fabric Group P0 | Delivered Pricing Pallas Fabric Group P1 | Delivered Pricing Pallas Fabric Group P2 | Delivered Pricing Pallas Fabric Group P3 | Delivered Pricing Pallas Fabric Group P4 |
|-------------------------|---------------------------------|---|----------------------------------|----------------------------------|--------------------------|----------------------------------|--|--|--|--|--|
| 33.0# | \$ 397 | | | | | | | | | | |
| 33.0# | 397 | | | | | | | | | | |
| 35.0# | N/A | 464 | 492 | 506 | 464 | 506 | 505 | 546 | 567 | 588 | 608 |
| 35.0# | N/A | 464 | 492 | 506 | 464 | 506 | 505 | 546 | 567 | 588 | 608 |
| 35.0# | N/A | 520 | 549 | 563 | 520 | 563 | 562 | 602 | 623 | 645 | 664 |
| 35.0# | N/A | 520 | 549 | 563 | 520 | 563 | 562 | 602 | 623 | 645 | 664 |
| 33.0# | \$ 464 | | | | | | | | | | |
| 33.0# | 464 | | | | | | | | | | |
| 35.0# | N/A | 528 | 624 | 639 | 528 | 639 | 639 | 678 | 700 | 719 | 740 |
| 35.0# | N/A | 528 | 624 | 639 | 528 | 639 | 639 | 678 | 700 | 719 | 740 |
| 35.0# | N/A | 584 | 680 | 695 | 584 | 695 | 695 | 734 | 755 | 775 | 798 |
| 35.0# | N/A | 584 | 680 | 695 | 584 | 695 | 695 | 734 | 755 | 775 | 798 |

UPHOLSTERY INFORMATION

C.O.M. Upholstery

C.O.M. requirement for 10 chairs or less with upholstered seat or upholstered seat and back is 3/4 yard per chair of 54" wide nondirectional fabric. For orders of 11 or more with upholstered seat and back and for complete information on ordering C.O.M. see "Ordering C.O.M., C.O.V. and C.O.L." section.

OPTIONS

California TB133 Fire Safety Code

The above seating products can be manufactured using the appropriate flame-retardant materials for compliance to California Technical Bulletin 133.

Model=Polypropylene
 Added List Price=\$10

Model=Upholstered Seat
 Added List Price=\$73

Model=Upholstered Seat and Back
 Added List Price=\$104

SPECIAL SERVICES

Special Carton Marking

With specially marked information N/C



Shipping

Ships **assembled, FOB Green Bay, WI 54302, freight prepaid.** Freight class 125.

Specifications and prices are subject to change without prior notice.

Stack/Nesting

Strive® Chairs

| Features | MODEL NUMBER | | | | | | | | Approx. Packaged Weight | |
|--|---------------------------|--------------|--------------------------|--------------------------|--------------------------|--------------------------|--------------------------|--------------------------|-------------------------|----------|
| | Basic Model | Frame Color | Seat & Back Color | Top Stitch Color | Glide Option | Tablet Arm Color | Fire Code | Upholstery Color | | |
|  <p>SLTS SLBTS Four-Leg Tablet Arm Chair with Top Stitch on Seat</p> <ul style="list-style-type: none"> Flex back NONSTACKING | Uph Seat, Left Hand | SLTATSULH | <input type="checkbox"/> | <input type="checkbox"/> | <input type="checkbox"/> | <input type="checkbox"/> | <input type="checkbox"/> | <input type="checkbox"/> | 35.0# | |
| | Uph Seat, Right Hand | SLTATSURH | <input type="checkbox"/> | <input type="checkbox"/> | <input type="checkbox"/> | <input type="checkbox"/> | <input type="checkbox"/> | <input type="checkbox"/> | 35.0# | |
| | Uph Seat/Back, Left Hand | SLTATSUBLH | <input type="checkbox"/> | <input type="checkbox"/> | <input type="checkbox"/> | <input type="checkbox"/> | <input type="checkbox"/> | <input type="checkbox"/> | 35.0# | |
| | Uph Seat/Back, Right Hand | SLTATSUBRH | <input type="checkbox"/> | <input type="checkbox"/> | <input type="checkbox"/> | <input type="checkbox"/> | <input type="checkbox"/> | <input type="checkbox"/> | 35.0# | |
|  <p>SLTS SLBTS Four-Leg Oversize Tablet Arm Chair with Top Stitch on Seat</p> <ul style="list-style-type: none"> Oversized tablet Flex back NONSTACKING | Uph Seat, Left Hand | SLOVTATSULH | <input type="checkbox"/> | <input type="checkbox"/> | <input type="checkbox"/> | <input type="checkbox"/> | <input type="checkbox"/> | <input type="checkbox"/> | 35.0# | |
| | Uph Seat, Right Hand | SLOVTATSURH | <input type="checkbox"/> | <input type="checkbox"/> | <input type="checkbox"/> | <input type="checkbox"/> | <input type="checkbox"/> | <input type="checkbox"/> | 35.0# | |
| | Uph Seat/Back, Left Hand | SLOVTATSUBLH | <input type="checkbox"/> | <input type="checkbox"/> | <input type="checkbox"/> | <input type="checkbox"/> | <input type="checkbox"/> | <input type="checkbox"/> | 35.0# | |
| | Uph Seat/Back, Right Hand | SLOVTATSUBRH | <input type="checkbox"/> | <input type="checkbox"/> | <input type="checkbox"/> | <input type="checkbox"/> | <input type="checkbox"/> | <input type="checkbox"/> | 35.0# | |
| | | | A | B | C | D | E | F | G | H |

HOW TO ORDER

Indicate the following information on order form:

- Quantity of each item.
- Model number, including options. See "How To Build a Model Number".
- Any special service required.

Note: • The indicates that a choice is required.

- The absence of the indicates that no choice is required.
- Alpha-numeric characters in place of indicate that no other alternatives are available.

HOW TO BUILD A MODEL NUMBER

A Select basic model.

B Select frame color.
Refer to the **Product Color Options** page in this price list.

C Select poly seat and back color.
Refer to the **Product Color Options** page in this price list.

D Select top stitch color.
BLTS - Black
WHTS - White

E Select glide option.
F - Felt Glides
P - Plastic glides
S - Steel glides

F Select tablet arm color.
Refer to the **Product Color Options** page in this price list.

G Select fire code.

NFR - Compliance to TB 117-2013
FR - Compliance to TB 133

H Select upholstery grade/color.
Refer to ki.com/fabrics



Delivered
Pricing
Pallas Fabric
Group P1

\$ 589
589
646
646

\$ 721
721
776
776

UPHOLSTERY INFORMATION

C.O.M. Upholstery

C.O.M. requirement for 10 chairs or less with upholstered seat or upholstered seat and back is 3/4 yard per chair of 54" wide nondirectional fabric. For orders of 11 or more with upholstered seat and back and for complete information on ordering C.O.M. see "Ordering C.O.M., C.O.V. and C.O.L." section.

OPTIONS

California TB133 Fire Safety Code

The above seating products can be manufactured using the appropriate flame-retardant materials for compliance to California Technical Bulletin 133.

Model=Polypropylene
Added List Price=\$10

Model=Upholstered Seat
Added List Price=\$73

Model=Upholstered Seat and Back
Added List Price=\$104

SPECIAL SERVICES

Special Carton Marking

With specially marked information N/C



Shipping

Ships **assembled, FOB Green Bay, WI 54302, freight prepaid.** Freight class 125.

Specifications and prices are subject to change without prior notice.

Stack/Nesting

Strive® Chairs

| | MODEL | Features | MODEL NUMBER | | | | | |
|--|---|-----------------------|--------------|--------------------------|--------------------------|--------------|--------------------------|--------------------------|
| | | | Basic Model | Frame Color | Seat & Back Color | Glide Option | Fire Code | Upholstery Color |
|  <p>SLP SLU SLUB</p> | Four-Leg Wallsaver Armless Chair • Flex back • Stacking • Wallsaver rear legs touch base of wall preventing chair back from contacting wall surface | Polypropylene | SLNAPWS | <input type="checkbox"/> | <input type="checkbox"/> | S | <input type="checkbox"/> | |
| | | Upholstered Seat | SLNAUWS | <input type="checkbox"/> | <input type="checkbox"/> | S | <input type="checkbox"/> | <input type="checkbox"/> |
| | | Upholstered Seat/Back | SLNAUBWS | <input type="checkbox"/> | <input type="checkbox"/> | S | <input type="checkbox"/> | <input type="checkbox"/> |
| | | | | | | | | |
|  <p>SLP SLU SLUB</p> | Four-Leg Wallsaver Cantilever Armchair • Flex back • Stacking • Wallsaver rear legs touch base of wall preventing chair back from contacting wall surface | Polypropylene | SLCAPWS | <input type="checkbox"/> | <input type="checkbox"/> | S | <input type="checkbox"/> | |
| | | Upholstered Seat | SLCAUWS | <input type="checkbox"/> | <input type="checkbox"/> | S | <input type="checkbox"/> | <input type="checkbox"/> |
| | | Upholstered Seat/Back | SLCAUBWS | <input type="checkbox"/> | <input type="checkbox"/> | S | <input type="checkbox"/> | <input type="checkbox"/> |
| | | | | | | | | |
|  <p>SLP SLU SLUB</p> | Four-Leg Wallsaver Loop Arm Chair • Flex back • Stacking • Wallsaver rear legs touch base of wall preventing chair back from contacting wall surface | Polypropylene | SLLAPWS | <input type="checkbox"/> | <input type="checkbox"/> | S | <input type="checkbox"/> | |
| | | Upholstered Seat | SLLAUWS | <input type="checkbox"/> | <input type="checkbox"/> | S | <input type="checkbox"/> | <input type="checkbox"/> |
| | | Upholstered Seat/Back | SLLAUBWS | <input type="checkbox"/> | <input type="checkbox"/> | S | <input type="checkbox"/> | <input type="checkbox"/> |
| | | | | | | | | |

A **B** **C** **D** **E** **F**

HOW TO ORDER

Indicate the following information on order form:

- Quantity of each item.
- Model number, including options. See "How To Build a Model Number".
- Any special service required.

Note: • The indicates that a choice is required.

- The absence of the indicates that no choice is required.
- Alpha-numeric characters in place of indicate that no other alternatives are available.

HOW TO BUILD A MODEL NUMBER

- A** Select basic model.
- B** Select frame color.
Refer to the **Product Color Options** page in this price list.
- C** Select seat and back color.
Refer to the **Product Color Options** page in this price list.
- D** Select glide option.
S - Steel glides
- E** Select fire code.
FR - Compliance to TB 133
NFR - Compliance to TB 117-2013
- F** Select upholstery grade/color.
Refer to ki.com/fabrics



| Approx. Packaged Weight | Delivered Pricing | Delivered Pricing Fabric Grade 1 & C.O.M. | Delivered Pricing Fabric Grade 2 | Delivered Pricing Fabric Grade 3 | Delivered Pricing C.O.V. | Delivered Pricing Vinyl Group 2V | Delivered Pricing Pallas Fabric Group P0 | Delivered Pricing Pallas Fabric Group P1 | Delivered Pricing Pallas Fabric Group P2 | Delivered Pricing Pallas Fabric Group P3 | Delivered Pricing Pallas Fabric Group P4 |
|-------------------------|-------------------|---|----------------------------------|----------------------------------|--------------------------|----------------------------------|--|--|--|--|--|
| 20.0# | \$ 250 | | | | | | | | | | |
| 23.0# | N/A | 315 | 344 | 361 | 315 | 361 | 358 | 397 | 420 | 442 | 461 |
| 23.0# | N/A | 371 | 401 | 416 | 371 | 416 | 414 | 454 | 474 | 497 | 518 |
| 23.0# | \$ 311 | | | | | | | | | | |
| 26.0# | N/A | 376 | 408 | 421 | 376 | 421 | 420 | 460 | 483 | 503 | 523 |
| 26.0# | N/A | 433 | 464 | 477 | 433 | 477 | 477 | 517 | 537 | 560 | 579 |
| 25.0# | \$ 327 | | | | | | | | | | |
| 27.0# | N/A | 392 | 421 | 434 | 392 | 434 | 433 | 472 | 495 | 518 | 534 |
| 27.0# | N/A | 447 | 477 | 490 | 447 | 490 | 489 | 528 | 551 | 572 | 591 |

UPHOLSTERY INFORMATION

C.O.M. Upholstery

C.O.M. requirement for 10 chairs or less with upholstered seat or upholstered seat and back is 3/4 yard per chair of 54" wide nondirectional fabric. For orders of 11 or more with upholstered seat and back and for complete information on ordering C.O.M. see "Ordering C.O.M., C.O.V. and C.O.L." section.

OPTIONS

California TB133 Fire Safety Code

The above seating products can be manufactured using the appropriate flame-retardant materials for compliance to California Technical Bulletin 133.

Model=Polypropylene
 Added List Price=\$10

Model=Upholstered Seat
 Added List Price=\$73

Model=Upholstered Seat and Back
 Added List Price=\$104

SPECIAL SERVICES

Special Carton Marking

With specially marked information N/C



Shipping

Ships **assembled, FOB Green Bay, WI 54302, freight prepaid.** Freight class 125.

Specifications and prices are subject to change without prior notice.

Stack/Nesting

Strive® Chairs

| | MODEL | Features | MODEL NUMBER | | | | | | | |
|--|---|-----------------------|--------------|--------------------------|--------------------------|--------------------------|--------------------------|-----------|--------------------------|--------------------------|
| | | | Basic Model | Frame Color | Seat & Back Color | Top Stitch Color | Glide Option | Fire Code | Upholstery Color | |
|  <p>SLTS SLBTS</p> | Four-Leg Wallsaver Armless Chair with Top Stitch on Seat • Flex back • Stacking • Wallsaver rear legs touch base of wall preventing chair back from contacting wall surface | Upholstered Seat | SLNATSUWS | <input type="checkbox"/> | <input type="checkbox"/> | <input type="checkbox"/> | <input type="checkbox"/> | S | <input type="checkbox"/> | <input type="checkbox"/> |
| | | Upholstered Seat/Back | SLNATSUBWS | <input type="checkbox"/> | <input type="checkbox"/> | <input type="checkbox"/> | <input type="checkbox"/> | S | <input type="checkbox"/> | <input type="checkbox"/> |
|  <p>SLTS SLBTS</p> | Four-Leg Wallsaver Cantilever Armchair with Top Stitch on Seat • Flex back • Stacking • Wallsaver rear legs touch base of wall preventing chair back from contacting wall surface | Upholstered Seat | SLCATSUWS | <input type="checkbox"/> | <input type="checkbox"/> | <input type="checkbox"/> | <input type="checkbox"/> | S | <input type="checkbox"/> | <input type="checkbox"/> |
| | | Upholstered Seat/Back | SLCATSUBWS | <input type="checkbox"/> | <input type="checkbox"/> | <input type="checkbox"/> | <input type="checkbox"/> | S | <input type="checkbox"/> | <input type="checkbox"/> |
|  <p>SLTS SLBTS</p> | Four-Leg Wallsaver Loop Arm Chair with Top Stitch on Seat • Flex back • Stacking • Wallsaver rear legs touch base of wall preventing chair back from contacting wall surface | Upholstered Seat | SLLATSUWS | <input type="checkbox"/> | <input type="checkbox"/> | <input type="checkbox"/> | <input type="checkbox"/> | S | <input type="checkbox"/> | <input type="checkbox"/> |
| | | Upholstered Seat/Back | SLLATSUBWS | <input type="checkbox"/> | <input type="checkbox"/> | <input type="checkbox"/> | <input type="checkbox"/> | S | <input type="checkbox"/> | <input type="checkbox"/> |

A **B** **C** **D** **E** **F** **G**

HOW TO ORDER

Indicate the following information on order form:

- Quantity of each item.
- Model number, including options. See "How To Build a Model Number".
- Any special service required.

Note: • The indicates that a choice is required.

- The absence of the indicates that no choice is required.
- Alpha-numeric characters in place of indicate that no other alternatives are available.

HOW TO BUILD A MODEL NUMBER

- A** Select basic model.
- B** Select frame color.
Refer to the **Product Color Options** page in this price list.
- C** Select seat and back color.
Refer to the **Product Color Options** page in this price list.
- D** Select top stitch color.

| | |
|-------------|---------|
| BLTS | - Black |
| WHTS | - White |
- E** Select glide option.

| | |
|----------|----------------|
| S | - Steel glides |
|----------|----------------|
- F** Select fire code.

| | |
|------------|-----------------------------|
| NFR | - Compliance to TB 117-2013 |
| FR | - Compliance to TB 133 |
- G** Select upholstery grade/color.
Refer to ki.com/fabrics



| Approx. Packaged Weight | Delivered Pricing Pallas Fabric Group P1 |
|-------------------------|--|
| 23.0# | \$ 441 |
| 23.0# | 496 |

| | |
|-------|--------|
| 26.0# | \$ 503 |
| 26.0# | 560 |

| | |
|-------|--------|
| 27.0# | \$ 518 |
| 27.0# | 572 |

UPHOLSTERY INFORMATION

C.O.M. Upholstery

C.O.M. requirement for 10 chairs or less with upholstered seat or upholstered seat and back is 3/4 yard per chair of 54" wide nondirectional fabric. For orders of 11 or more with upholstered seat and back and for complete information on ordering C.O.M. see "Ordering C.O.M., C.O.V. and C.O.L." section.

OPTIONS

California TB133 Fire Safety Code

The above seating products can be manufactured using the appropriate flame-retardant materials for compliance to California Technical Bulletin 133.

Model=Polypropylene
Added List Price=\$10

Model=Upholstered Seat
Added List Price=\$73

Model=Upholstered Seat and Back
Added List Price=\$104

SPECIAL SERVICES

Special Carton Marking

With specially marked information N/C



Shipping

Ships **assembled, FOB Green Bay, WI 54302, freight prepaid.** Freight class 125.

Specifications and prices are subject to change without prior notice.

Stack/Nesting

Strive® Chairs

| | MODEL | Features | MODEL NUMBER | | | | | | Approx. Packaged Weight |
|---|--|-----------------------|--------------|--------------------------|--------------------------|--------------------------|--------------------------|--------------------------|-------------------------|
| | | | Basic Model | Frame Color | Seat & Back Color | Glide Option | Fire Code | Upholstery Color | |
|  <p>SSP SSU SSUB</p> | Sled Base Armless Chair • Flex back • Stacking | Polypropylene | SSNAP | <input type="checkbox"/> | <input type="checkbox"/> | <input type="checkbox"/> | <input type="checkbox"/> | <input type="checkbox"/> | 22.0# |
| | | Upholstered Seat | SSNAU | <input type="checkbox"/> | <input type="checkbox"/> | <input type="checkbox"/> | <input type="checkbox"/> | <input type="checkbox"/> | 25.0# |
| | | Upholstered Seat/Back | SSNAUB | <input type="checkbox"/> | <input type="checkbox"/> | <input type="checkbox"/> | <input type="checkbox"/> | <input type="checkbox"/> | 25.0# |
| | | | | | | | | | |
|  <p>SSP SSU SSUB</p> | Sled Base Cantilever Arm Chair • Flex back • Stacking | Polypropylene | SSCAP | <input type="checkbox"/> | <input type="checkbox"/> | <input type="checkbox"/> | <input type="checkbox"/> | <input type="checkbox"/> | 24.0# |
| | | Upholstered Seat | SSCAU | <input type="checkbox"/> | <input type="checkbox"/> | <input type="checkbox"/> | <input type="checkbox"/> | <input type="checkbox"/> | 27.0# |
| | | Upholstered Seat/Back | SSCAUB | <input type="checkbox"/> | <input type="checkbox"/> | <input type="checkbox"/> | <input type="checkbox"/> | <input type="checkbox"/> | 27.0# |
| | | | | | | | | | |

A **B** **C** **D** **E** **F**

HOW TO ORDER

Indicate the following information on order form:

- Quantity of each item.
- Model number, including options. See "How To Build a Model Number".
- Any special service required.

Note: • The indicates that a choice is required.

- The absence of the indicates that no choice is required.
- Alpha-numeric characters in place of indicate that no other alternatives are available.

HOW TO BUILD A MODEL NUMBER

- A** Select basic model.
- B** Select frame color.
Refer to the **Product Color Options** page in this price list.
- C** Select poly seat and back color.
Refer to the **Product Color Options** page in this price list.
- D** Select glide option.

| | |
|------------|-----------------------------------|
| NG | - No glides |
| GBL | - Black plastic glides; add \$36 |
| NS | - Non-skid glides; add \$30 |
| GSS | - Stainless steel glide; add \$31 |
- E** Select fire code.

| | |
|------------|-----------------------------|
| FR | - Compliance to TB 133 |
| NFR | - Compliance to TB 117-2013 |
- F** Select upholstery grade/color.
Refer to ki.com/fabrics



| Delivered Pricing Upholstered | Delivered Pricing Fabric Grade 1 & C.O.M. | Delivered Pricing Fabric Grade 2 | Delivered Pricing Fabric Grade 3 | Delivered Pricing C.O.V. | Delivered Pricing Vinyl Group 2V | Delivered Pricing Pallas Fabric Group P0 | Delivered Pricing Pallas Fabric Group P1 | Delivered Pricing Pallas Fabric Group P2 | Delivered Pricing Pallas Fabric Group P3 | Delivered Pricing Pallas Fabric Group P4 | |
|-------------------------------|---|----------------------------------|----------------------------------|--------------------------|----------------------------------|--|--|--|--|--|-----|
| \$ 234 | N/A | 300 | 331 | 341 | 300 | 341 | 341 | 381 | 402 | 424 | 443 |
| N/A | 355 | 384 | 397 | 355 | 397 | 397 | 437 | 459 | 480 | 499 | |
| <hr/> | | | | | | | | | | | |
| \$ 296 | N/A | 363 | 391 | 404 | 363 | 404 | 402 | 442 | 465 | 487 | 505 |
| N/A | 417 | 445 | 460 | 417 | 460 | 458 | 497 | 521 | 542 | 562 | |

UPHOLSTERY INFORMATION

C.O.M. Upholstery

C.O.M. requirement for 10 chairs or less with upholstered seat or upholstered seat and back is 3/4 yard per chair of 54" wide nondirectional fabric. For orders of 11 or more with upholstered seat and back and for complete information on ordering C.O.M. see "Ordering C.O.M., C.O.V. and C.O.L." section.

OPTIONS

California TB133 Fire Safety Code

The above seating products can be manufactured using the appropriate flame-retardant materials for compliance to California Technical Bulletin 133.

Model=Polypropylene
Added List Price=\$10

Model=Upholstered Seat
Added List Price=\$73

Model=Upholstered Seat and Back
Added List Price=\$104

SPECIAL SERVICES

Special Carton Marking

With specially marked information N/C



Shipping

Ships **assembled, FOB Green Bay, WI 54302, freight prepaid.** Freight class 125.

Specifications and prices are subject to change without prior notice.

Stack/Nesting

Strive® Chairs

| | MODEL | Features | MODEL NUMBER | | | | | | |
|--|---|-----------------------|--------------|---|---|---|--|--|---|
| | | | Basic Model | Frame Color | Seat & Back Color | Top Stitch Color | Glide Option | Fire Code | Upholstery Color |
|  <p>SSTS SSBT</p> | Sled Base Armless Chair with Top Stitch on Seat | Upholstered Seat | SSNATSU | <input type="checkbox"/> <input type="checkbox"/> | <input type="checkbox"/> <input type="checkbox"/> <input type="checkbox"/> <input type="checkbox"/> | <input type="checkbox"/> <input type="checkbox"/> <input type="checkbox"/> <input type="checkbox"/> <input type="checkbox"/> <input type="checkbox"/> | <input type="checkbox"/> <input type="checkbox"/> <input type="checkbox"/> | <input type="checkbox"/> <input type="checkbox"/> <input type="checkbox"/> | <input type="checkbox"/> <input type="checkbox"/> <input type="checkbox"/> <input type="checkbox"/> <input type="checkbox"/> <input type="checkbox"/> |
| | | Upholstered Seat/Back | SSNATSUB | <input type="checkbox"/> <input type="checkbox"/> | <input type="checkbox"/> <input type="checkbox"/> <input type="checkbox"/> <input type="checkbox"/> | <input type="checkbox"/> <input type="checkbox"/> <input type="checkbox"/> <input type="checkbox"/> <input type="checkbox"/> <input type="checkbox"/> | <input type="checkbox"/> <input type="checkbox"/> <input type="checkbox"/> | <input type="checkbox"/> <input type="checkbox"/> <input type="checkbox"/> | <input type="checkbox"/> <input type="checkbox"/> <input type="checkbox"/> <input type="checkbox"/> <input type="checkbox"/> <input type="checkbox"/> |
| | | | | | | | | | |
| | | | | | | | | | |
|  <p>SSTS SSBT</p> | Sled Base Cantilever Arm Chair with Top Stitch on Seat | Upholstered Seat | SSCATSU | <input type="checkbox"/> <input type="checkbox"/> | <input type="checkbox"/> <input type="checkbox"/> <input type="checkbox"/> <input type="checkbox"/> | <input type="checkbox"/> <input type="checkbox"/> <input type="checkbox"/> <input type="checkbox"/> <input type="checkbox"/> <input type="checkbox"/> | <input type="checkbox"/> <input type="checkbox"/> <input type="checkbox"/> | <input type="checkbox"/> <input type="checkbox"/> <input type="checkbox"/> | <input type="checkbox"/> <input type="checkbox"/> <input type="checkbox"/> <input type="checkbox"/> <input type="checkbox"/> <input type="checkbox"/> |
| | | Upholstered Seat/Back | SSCATSUB | <input type="checkbox"/> <input type="checkbox"/> | <input type="checkbox"/> <input type="checkbox"/> <input type="checkbox"/> <input type="checkbox"/> | <input type="checkbox"/> <input type="checkbox"/> <input type="checkbox"/> <input type="checkbox"/> <input type="checkbox"/> <input type="checkbox"/> | <input type="checkbox"/> <input type="checkbox"/> <input type="checkbox"/> | <input type="checkbox"/> <input type="checkbox"/> <input type="checkbox"/> | <input type="checkbox"/> <input type="checkbox"/> <input type="checkbox"/> <input type="checkbox"/> <input type="checkbox"/> <input type="checkbox"/> |
| | | | | | | | | | |
| | | | | | | | | | |

A **B** **C** **D** **E** **F** **G**

HOW TO ORDER

Indicate the following information on order form:

- Quantity of each item.
- Model number, including options. See "How To Build a Model Number".
- Any special service required.

Note: • The indicates that a choice is required.
 • The absence of the indicates that no choice is required.
 • Alpha-numeric characters in place of indicate that no other alternatives are available.

HOW TO BUILD A MODEL NUMBER

- A** Select basic model.
- B** Select frame color.
Refer to the **Product Color Options** page in this price list.
- C** Select seat and back color.
Refer to the **Product Color Options** page in this price list.
- D** Select top stitch color.
BLTS - Black
WHTS - White
- E** Select glide option.
NG - No glides
GBL - Black plastic glides; add \$36
NS - Non-skid glides; add \$30
GSS - Stainless steel glide; add \$31
- F** Select fire code.
FR - Compliance to TB 133
NFR - Compliance to TB 117-2013

G Select upholstery grade/color.
Refer to ki.com/fabrics



| Approx. Packaged Weight | Delivered Pricing Pallas Fabric Group P1 |
|-------------------------------|---|
| 25.0# | \$ 424 |
| 25.0# | 480 |

| | |
|-------|--------|
| 27.0# | \$ 486 |
| 27.0# | 541 |

UPHOLSTERY INFORMATION

C.O.M. Upholstery

C.O.M. requirement for 10 chairs or less with upholstered seat or upholstered seat and back is 3/4 yard per chair of 54" wide nondirectional fabric. For orders of 11 or more with upholstered seat and back and for complete information on ordering C.O.M. see "Ordering C.O.M., C.O.V. and C.O.L." section.

OPTIONS

California TB133 Fire Safety Code

The above seating products can be manufactured using the appropriate flame-retardant materials for compliance to California Technical Bulletin 133.

Model=Polypropylene
 Added List Price=\$10

Model=Upholstered Seat
 Added List Price=\$73

Model=Upholstered Seat and Back
 Added List Price=\$104

SPECIAL SERVICES

Special Carton Marking

With specially marked information N/C



Shipping

Ships **assembled, FOB Green Bay, WI 54302, freight prepaid.** Freight class 125.

Specifications and prices are subject to change without prior notice.

Stack/Nesting

Strive® Chairs

| MODEL | Features | MODEL NUMBER | | | | | | |
|--|----------------------------|--------------|--------------------------|--------------------------|--------------------------|--------------------------|--------------------------|--------------------------|
| | | Basic Model | Frame Color | Seat & Back Color | Glide Option | Tablet Arm Color | Fire Code | Upholstery Color |
|  <p>Sled Base Tablet Arm Chair</p> <ul style="list-style-type: none"> Flex back NONSTACKING | Polypropylene, Left Hand | SSTAPLH | <input type="checkbox"/> | <input type="checkbox"/> | <input type="checkbox"/> | <input type="checkbox"/> | <input type="checkbox"/> | |
| | Polypropylene, Right Hand | SSTAPRH | <input type="checkbox"/> | <input type="checkbox"/> | <input type="checkbox"/> | <input type="checkbox"/> | <input type="checkbox"/> | |
| | Uph. Seat, Left Hand | SSTAULH | <input type="checkbox"/> | <input type="checkbox"/> | <input type="checkbox"/> | <input type="checkbox"/> | <input type="checkbox"/> | <input type="checkbox"/> |
| | Uph. Seat, Right Hand | SSTAURH | <input type="checkbox"/> | <input type="checkbox"/> | <input type="checkbox"/> | <input type="checkbox"/> | <input type="checkbox"/> | <input type="checkbox"/> |
| | Upholstered Seat/Back | SSTAUBLH | <input type="checkbox"/> | <input type="checkbox"/> | <input type="checkbox"/> | <input type="checkbox"/> | <input type="checkbox"/> | <input type="checkbox"/> |
| | Upholstered Seat/Back | SSTAUBRH | <input type="checkbox"/> | <input type="checkbox"/> | <input type="checkbox"/> | <input type="checkbox"/> | <input type="checkbox"/> | <input type="checkbox"/> |
| | | | | | | | | |
|  <p>Sled Base Oversize Tablet Arm Chair</p> <ul style="list-style-type: none"> Oversized tablet Flex back NONSTACKING | Polypropylene, Left Hand | SSOVTAPLH | <input type="checkbox"/> | <input type="checkbox"/> | <input type="checkbox"/> | <input type="checkbox"/> | <input type="checkbox"/> | |
| | Polypropylene, Right Hand | SSOVTAPRH | <input type="checkbox"/> | <input type="checkbox"/> | <input type="checkbox"/> | <input type="checkbox"/> | <input type="checkbox"/> | |
| | Uph. Seat, Left Hand | SSOVTALH | <input type="checkbox"/> | <input type="checkbox"/> | <input type="checkbox"/> | <input type="checkbox"/> | <input type="checkbox"/> | <input type="checkbox"/> |
| | Uph. Seat, Right Hand | SSOVTARH | <input type="checkbox"/> | <input type="checkbox"/> | <input type="checkbox"/> | <input type="checkbox"/> | <input type="checkbox"/> | <input type="checkbox"/> |
| | Uph. Seat/Back, Left Hand | SSOVTABLH | <input type="checkbox"/> | <input type="checkbox"/> | <input type="checkbox"/> | <input type="checkbox"/> | <input type="checkbox"/> | <input type="checkbox"/> |
| | Uph. Seat/Back, Right Hand | SSOVTABRH | <input type="checkbox"/> | <input type="checkbox"/> | <input type="checkbox"/> | <input type="checkbox"/> | <input type="checkbox"/> | <input type="checkbox"/> |
| | | | | | | | | |
| | | | | | | | | |

SSP
SSU
SSUB

SSP
SSU
SSUB

A **B** **C** **D** **E** **F** **G**

HOW TO ORDER

Indicate the following information on order form:

- Quantity of each item.
- Model number, including options. See "How To Build a Model Number".
- Any special service required.

Note: • The indicates that a choice is required.

- The absence of the indicates that no choice is required.
- Alpha-numeric characters in place of indicate that no other alternatives are available.

HOW TO BUILD A MODEL NUMBER

G Select upholstery grade/color. Refer to ki.com/fabrics

A Select basic model.

B Select frame color. Refer to the **Product Color Options** page in this price list.

C Select poly seat and back color. Refer to the **Product Color Options** page in this price list.

D Select glide option.

| | |
|------------|-----------------------------------|
| NG | - No glides |
| GBL | - Black plastic glides; add \$36 |
| NS | - Non-skid glides; add \$30 |
| GSS | - Stainless steel glide; add \$31 |

E Select tablet arm color. Refer to the **Product Color Options** page in this price list.

F Select fire code.

| | |
|------------|-----------------------------|
| NFR | - Compliance to TB 117-2013 |
| FR | - Compliance to TB 133 |



| Approx. Packaged Weight | Delivered Pricing Unupholstered | Delivered Pricing Fabric Grade 1 & C.O.M. | Delivered Pricing Fabric Grade 2 | Delivered Pricing Fabric Grade 3 | Delivered Pricing C.O.V. | Delivered Pricing Vinyl Group 2V | Delivered Pricing Pallas Fabric Group P0 | Delivered Pricing Pallas Fabric Group P1 | Delivered Pricing Pallas Fabric Group P2 | Delivered Pricing Pallas Fabric Group P3 | Delivered Pricing Pallas Fabric Group P4 |
|-------------------------|---------------------------------|---|----------------------------------|----------------------------------|--------------------------|----------------------------------|--|--|--|--|--|
| 31.0# | \$ 443 | | | | | | | | | | |
| 31.0# | 443 | | | | | | | | | | |
| 33.0# | N/A | 510 | 540 | 555 | 510 | 555 | 550 | 591 | 616 | 634 | 654 |
| 33.0# | N/A | 510 | 540 | 555 | 510 | 555 | 550 | 591 | 616 | 634 | 654 |
| 33.0# | N/A | 565 | 595 | 610 | 565 | 610 | 607 | 648 | 672 | 690 | 710 |
| 33.0# | N/A | 565 | 595 | 610 | 565 | 610 | 607 | 648 | 672 | 690 | 710 |
| 31.0# | \$ 510 | | | | | | | | | | |
| 31.0# | 510 | | | | | | | | | | |
| 33.0# | N/A | 576 | 606 | 620 | 576 | 620 | 617 | 656 | 680 | 701 | 719 |
| 33.0# | N/A | 576 | 606 | 620 | 576 | 620 | 617 | 656 | 680 | 701 | 719 |
| 33.0# | N/A | 631 | 660 | 676 | 631 | 676 | 673 | 712 | 736 | 756 | 775 |
| 33.0# | N/A | 631 | 660 | 676 | 631 | 676 | 673 | 712 | 736 | 756 | 775 |

UPHOLSTERY INFORMATION

C.O.M. Upholstery

C.O.M. requirement for 10 chairs or less with upholstered seat or upholstered seat and back is 3/4 yard per chair of 54" wide nondirectional fabric. For orders of 11 or more with upholstered seat and back and for complete information on ordering C.O.M. see "Ordering C.O.M., C.O.V. and C.O.L." section.

OPTIONS

California TB133 Fire Safety Code

The above seating products can be manufactured using the appropriate flame-retardant materials for compliance to California Technical Bulletin 133.

Model=Polypropylene
 Added List Price=\$10

Model=Upholstered Seat
 Added List Price=\$73

Model=Upholstered Seat and Back
 Added List Price=\$104

SPECIAL SERVICES

Special Carton Marking

With specially marked information N/C



Shipping

Ships **assembled, FOB Green Bay, WI 54302, freight prepaid.** Freight class 125.

Specifications and prices are subject to change without prior notice.

Stack/Nesting

Strive® Chairs

| Features | MODEL NUMBER | | | | | | | | Approx. Packaged Weight | |
|--|---------------------------|--------------|--------------------------|--------------------------|--------------------------|--------------------------|--------------------------|--------------------------|--------------------------|----------|
| | Basic Model | Frame Color | Seat & Back Color | Top Stitch Color | Glide Option | Tablet Arm Color | Fire Code | Upholstery Color | | |
|  <p>SSTS SSBT Sled Base Tablet Arm Chair with Top Stitch on Seat</p> <ul style="list-style-type: none"> Flex back NONSTACKING | Uph Seat, Left Hand | SSTALTSU | <input type="checkbox"/> | <input type="checkbox"/> | <input type="checkbox"/> | <input type="checkbox"/> | <input type="checkbox"/> | <input type="checkbox"/> | <input type="checkbox"/> | 33.0# |
| | Uph Seat, Right Hand | SSTARTSU | <input type="checkbox"/> | <input type="checkbox"/> | <input type="checkbox"/> | <input type="checkbox"/> | <input type="checkbox"/> | <input type="checkbox"/> | <input type="checkbox"/> | 33.0# |
| | Uph Seat/Back, Left Hand | SSTALTSUB | <input type="checkbox"/> | <input type="checkbox"/> | <input type="checkbox"/> | <input type="checkbox"/> | <input type="checkbox"/> | <input type="checkbox"/> | <input type="checkbox"/> | 33.0# |
| | Uph Seat/Back, Right Hand | SSTARTSUB | <input type="checkbox"/> | <input type="checkbox"/> | <input type="checkbox"/> | <input type="checkbox"/> | <input type="checkbox"/> | <input type="checkbox"/> | <input type="checkbox"/> | 33.0# |
|  <p>SSTS SSBT Sled Base Oversize Tablet Arm Chair with Top Stitch on Seat</p> <ul style="list-style-type: none"> Oversized tablet Flex back NONSTACKING | Uph Seat, Left Hand | SSOVTATSULH | <input type="checkbox"/> | <input type="checkbox"/> | <input type="checkbox"/> | <input type="checkbox"/> | <input type="checkbox"/> | <input type="checkbox"/> | <input type="checkbox"/> | 33.0# |
| | Uph Seat, Right Hand | SSOVTATSURH | <input type="checkbox"/> | <input type="checkbox"/> | <input type="checkbox"/> | <input type="checkbox"/> | <input type="checkbox"/> | <input type="checkbox"/> | <input type="checkbox"/> | 33.0# |
| | Uph Seat/Back, Left Hand | SSOVTATSUBLH | <input type="checkbox"/> | <input type="checkbox"/> | <input type="checkbox"/> | <input type="checkbox"/> | <input type="checkbox"/> | <input type="checkbox"/> | <input type="checkbox"/> | 33.0# |
| | Uph Seat/Back, Right Hand | SSOVTATSUBRH | <input type="checkbox"/> | <input type="checkbox"/> | <input type="checkbox"/> | <input type="checkbox"/> | <input type="checkbox"/> | <input type="checkbox"/> | <input type="checkbox"/> | 33.0# |
| | | | A | B | C | D | E | F | G | H |

HOW TO ORDER

Indicate the following information on order form:

- Quantity of each item.
- Model number, including options. See "How To Build a Model Number".
- Any special service required.

Note: • The indicates that a choice is required.

- The absence of the indicates that no choice is required.
- Alpha-numeric characters in place of indicate that no other alternatives are available.

HOW TO BUILD A MODEL NUMBER

A Select basic model.

B Select frame color.
Refer to the **Product Color Options** page in this price list.

C Select poly seat and back color.
Refer to the **Product Color Options** page in this price list.

D Select top stitch color.
BLTS - Black
WHTS - White

E Select glide option.
NG - No glides
GBL - Black plastic glides; add \$36
NS - Non-skid glides; add \$30
GSS - Stainless steel glide; add \$31

F Select tablet arm color.
Refer to the **Product Color Options** page in this price list.

G Select fire code.

FR - Compliance to TB 133
NFR - Compliance to TB 117-2013

H Select upholstery grade/color.
Refer to ki.com/fabrics



Delivered
Pricing
Pallas Fabric
Group P1

\$ 634
634
690
690

\$ 701
701
756
756

UPHOLSTERY INFORMATION

C.O.M. Upholstery

C.O.M. requirement for 10 chairs or less with upholstered seat or upholstered seat and back is 3/4 yard per chair of 54" wide nondirectional fabric. For orders of 11 or more with upholstered seat and back and for complete information on ordering C.O.M. see "Ordering C.O.M., C.O.V. and C.O.L." section.

OPTIONS

California TB133 Fire Safety Code

The above seating products can be manufactured using the appropriate flame-retardant materials for compliance to California Technical Bulletin 133.

Model=Polypropylene
Added List Price=\$10

Model=Upholstered Seat
Added List Price=\$73

Model=Upholstered Seat and Back
Added List Price=\$104

SPECIAL SERVICES

Special Carton Marking

With specially marked information N/C

Shipping

Ships **assembled, FOB Green Bay, WI 54302, freight prepaid.** Freight class 125.

Specifications and prices are subject to change without prior notice.

Stack/Nesting

Strive® Chairs

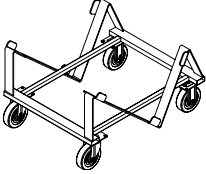
| MODEL | MODEL NUMBER | Approx. Packaged Weight |
|---|--------------|-------------------------|
| | Basic Model | |
|  <p>Transport Dolly for 4-Leg and Sled Base Chairs</p> <ul style="list-style-type: none"> • Easy maneuverability with 5" casters: two fixed, two swivel • Rugged weld tubular steel frame • Black powder-coated finish <p>HRDPT</p> | SCDA.BL | 31.0# |
| | | |
| | | |
| | | |
| | | |

A

HOW TO ORDER

Indicate the following information on order form:

1. Quantity of each item.
2. Model number, including options. See "How To Build a Model Number".
3. Any special service required.

Note: • The indicates that a choice is required.

- The absence of the indicates that no choice is required.
- Alpha-numeric characters in place of indicate that no other alternatives are available.

HOW TO BUILD A MODEL NUMBER

A Select basic model.



Delivered
Pricing
\$ 452

SPECIAL SERVICES

Special Carton Marking

With specially marked information N/C



Shipping

Ships **assembled, FOB Green Bay, WI 54302, freight prepaid.** Freight class 125.

Specifications and prices are subject to change without prior notice.

Stack/Nesting

Strive® Cafe Stools

| MODEL | Features | MODEL NUMBER | | | | | | |
|--|-----------------------|--------------|--------------------------|--------------------------|--------------------------|--------------------------|--------------------------|--------------------------|
| | | Basic Model | Seat Height | Frame Color | Seat & Back Color | Glide Option | Fire Code | Upholstery Color |
|  <p>Four-Leg Armless Cafe Stool</p> <ul style="list-style-type: none"> • Flex back • Stacking • Two seat heights | Polypropylene | SLSNAP | <input type="checkbox"/> | <input type="checkbox"/> | <input type="checkbox"/> | <input type="checkbox"/> | <input type="checkbox"/> | |
| | Upholstered Seat | SLSNAU | <input type="checkbox"/> | <input type="checkbox"/> | <input type="checkbox"/> | <input type="checkbox"/> | <input type="checkbox"/> | <input type="checkbox"/> |
| | Upholstered Seat/Back | SLSNAUB | <input type="checkbox"/> | <input type="checkbox"/> | <input type="checkbox"/> | <input type="checkbox"/> | <input type="checkbox"/> | <input type="checkbox"/> |
| | | | | | | | | |
|  <p>Four-Leg Cantilever Arm Cafe Stool</p> <ul style="list-style-type: none"> • Flex back • Stacking • Two seat heights | Polypropylene | SLSCAP | <input type="checkbox"/> | <input type="checkbox"/> | <input type="checkbox"/> | <input type="checkbox"/> | <input type="checkbox"/> | |
| | Upholstered Seat | SLSCAU | <input type="checkbox"/> | <input type="checkbox"/> | <input type="checkbox"/> | <input type="checkbox"/> | <input type="checkbox"/> | <input type="checkbox"/> |
| | Upholstered Seat/Back | SLSCAUB | <input type="checkbox"/> | <input type="checkbox"/> | <input type="checkbox"/> | <input type="checkbox"/> | <input type="checkbox"/> | <input type="checkbox"/> |
| | | | | | | | | |
|  <p>Four-Leg Loop Arm Cafe Stool</p> <ul style="list-style-type: none"> • Flex back • NONSTACKING • Two seat heights | Polypropylene | SLSLAP | <input type="checkbox"/> | <input type="checkbox"/> | <input type="checkbox"/> | <input type="checkbox"/> | <input type="checkbox"/> | |
| | Upholstered Seat | SLSLAU | <input type="checkbox"/> | <input type="checkbox"/> | <input type="checkbox"/> | <input type="checkbox"/> | <input type="checkbox"/> | <input type="checkbox"/> |
| | Upholstered Seat/Back | SLSLAUB | <input type="checkbox"/> | <input type="checkbox"/> | <input type="checkbox"/> | <input type="checkbox"/> | <input type="checkbox"/> | <input type="checkbox"/> |
| | | | | | | | | |

SLSP
SLSU
SLSUB

SLSP
SLSU
SLSUB

SLSP
SLSU
SLSUB

A **B** **C** **D** **E** **F** **G**

HOW TO ORDER

Indicate the following information on order form:

1. Quantity of each item.
2. Model number, including options. See "How To Build a Model Number".
3. Any special service required.

Note: • The indicates that a choice is required.

- The absence of the indicates that no choice is required.
- Alpha-numeric characters in place of indicate that no other alternatives are available.

HOW TO BUILD A MODEL NUMBER

- A** Select basic model.
- B** Select seat height.

| | |
|-----------|-------------------|
| 23 | - 23" Seat Height |
| 29 | - 29" Seat Height |
- C** Select frame color.
Refer to the **Product Color Options** page in this price list.
- D** Select poly seat and back color.
Refer to the **Product Color Options** page in this price list.
- E** Select glide option.

| | |
|----------|------------------|
| F | - Felt Glides |
| P | - Plastic glides |
| S | - Steel glides |
- F** Select fire code.

| | |
|------------|-----------------------------|
| FR | - Compliance to TB 133 |
| NFR | - Compliance to TB 117-2013 |

G Select upholstery grade/color.
Refer to ki.com/fabrics



| Approx. Packaged Weight | Delivered Pricing Unupholstered | Delivered Pricing Fabric Grade 1 & C.O.M. | Delivered Pricing Fabric Grade 2 | Delivered Pricing Fabric Grade 3 | Delivered Pricing C.O.V. | Delivered Pricing Vinyl Group 2V | Delivered Pricing Pallas Fabric Group P0 | Delivered Pricing Pallas Fabric Group P1 | Delivered Pricing Pallas Fabric Group P2 | Delivered Pricing Pallas Fabric Group P3 | Delivered Pricing Pallas Fabric Group P4 |
|-------------------------|---------------------------------|---|----------------------------------|----------------------------------|--------------------------|----------------------------------|--|--|--|--|--|
| 31.0# | \$ 307 | | | | | | | | | | |
| 33.0# | N/A | 373 | 404 | 418 | 373 | 418 | 417 | 457 | 479 | 500 | 520 |
| 33.0# | N/A | 430 | 460 | 473 | 430 | 473 | 471 | 512 | 534 | 557 | 576 |
| 33.0# | \$ 370 | | | | | | | | | | |
| 35.0# | N/A | 435 | 466 | 480 | 435 | 480 | 479 | 519 | 540 | 562 | 581 |
| 35.0# | N/A | 491 | 522 | 535 | 491 | 535 | 532 | 574 | 595 | 618 | 638 |
| 35.0# | \$ 383 | | | | | | | | | | |
| 37.0# | N/A | 449 | 480 | 492 | 449 | 492 | 491 | 530 | 555 | 576 | 593 |
| 37.0# | N/A | 505 | 535 | 549 | 505 | 549 | 547 | 587 | 610 | 631 | 650 |

UPHOLSTERY INFORMATION

C.O.M. Upholstery

C.O.M. requirement for 10 chairs or less with upholstered seat or upholstered seat and back is 3/4 yard per chair of 54" wide nondirectional fabric. For orders of 11 or more with upholstered seat and back and for complete information on ordering C.O.M. see "Ordering C.O.M., C.O.V. and C.O.L." section.

OPTIONS

California TB133 Fire Safety Code

The above seating products can be manufactured using the appropriate flame-retardant materials for compliance to California Technical Bulletin 133.

Model=Polypropylene
 Added List Price=\$10

Model=Upholstered Seat
 Added List Price=\$73

Model=Upholstered Seat and Back
 Added List Price=\$104

SPECIAL SERVICES

Special Carton Marking

With specially marked information N/C



Shipping

Ships **assembled, FOB Green Bay, WI 54302, freight prepaid.** Freight class 125.

Specifications and prices are subject to change without prior notice.

Stack/Nesting

Strive® Cafe Stools

| MODEL | Features | MODEL NUMBER | | | | | | | |
|--|-----------------------|--------------|--------------------------|--------------------------|--------------------------|--------------------------|--------------------------|--------------------------|--------------------------|
| | | Basic Model | Seat Height | Frame Color | Seat & Back Color | Top Stitch Color | Glide Option | Fire Code | Uph. Color |
|  <p>Four-Leg Armless Cafe Stool with Top Stitch on Seat</p> <ul style="list-style-type: none"> • Flex back • Stacking • Two seat heights | Upholstered Seat | SLSNATSU | <input type="checkbox"/> | <input type="checkbox"/> | <input type="checkbox"/> | <input type="checkbox"/> | <input type="checkbox"/> | <input type="checkbox"/> | <input type="checkbox"/> |
| | Upholstered Seat/Back | SLSNATSUB | <input type="checkbox"/> | <input type="checkbox"/> | <input type="checkbox"/> | <input type="checkbox"/> | <input type="checkbox"/> | <input type="checkbox"/> | <input type="checkbox"/> |
| SLSTS | | | | | | | | | |
| SLSBT | | | | | | | | | |
|  <p>Four-Leg Cantilever Arm Cafe Stool with Top Stitch on Seat</p> <ul style="list-style-type: none"> • Flex back • Stacking • Two seat heights | Upholstered Seat | SLSCATSU | <input type="checkbox"/> | <input type="checkbox"/> | <input type="checkbox"/> | <input type="checkbox"/> | <input type="checkbox"/> | <input type="checkbox"/> | |
| | Upholstered Seat/Back | SLSCATSUB | | <input type="checkbox"/> | <input type="checkbox"/> | <input type="checkbox"/> | <input type="checkbox"/> | <input type="checkbox"/> | <input type="checkbox"/> |
| SLSTS | | | | | | | | | |
| SLSBT | | | | | | | | | |
|  <p>Four-Leg Loop Arm Cafe Stool with Top Stitch on Seat</p> <ul style="list-style-type: none"> • Flex back • NONSTACKING • Two seat heights | Upholstered Seat | SLSLATSU | <input type="checkbox"/> | <input type="checkbox"/> | <input type="checkbox"/> | <input type="checkbox"/> | <input type="checkbox"/> | <input type="checkbox"/> | |
| | Upholstered Seat/Back | SLSLATSUB | <input type="checkbox"/> | <input type="checkbox"/> | <input type="checkbox"/> | <input type="checkbox"/> | <input type="checkbox"/> | <input type="checkbox"/> | <input type="checkbox"/> |
| SLSTS | | | | | | | | | |
| SLSBT | | | | | | | | | |

A **B** **C** **D** **E** **F** **G** **H**

HOW TO ORDER

Indicate the following information on order form:

1. Quantity of each item.
2. Model number, including options. See "How To Build a Model Number".
3. Any special service required.

Note: • The indicates that a choice is required.

- The absence of the indicates that no choice is required.
- Alpha-numeric characters in place of indicate that no other alternatives are available.

HOW TO BUILD A MODEL NUMBER

A Select basic model.

B Select seat height.
23 - 23" Seat Height
29 - 29" Seat Height

C Select frame color.
 Refer to the **Product Color Options** page in this price list.

D Select poly seat and back color.
 Refer to the **Product Color Options** page in this price list.

E Select top stitch color.
BLTS - Black
WHTS - White

F Select glide option.
F - Felt Glides
P - Plastic glides
S - Steel glides

G Select fire code.

FR - Compliance to TB 133
NFR - Compliance to TB 117-2013

H Select upholstery grade/color.
 Refer to ki.com/fabrics



| Approx. Packaged Weight | Delivered Pricing Pallas Fabric Group P1 |
|-------------------------------|---|
| 33.0# | \$ 499 |
| 33.0# | 556 |

| | |
|-------|--------|
| 35.0# | \$ 562 |
| 35.0# | 618 |

| | |
|-------|--------|
| 37.0# | \$ 576 |
| 37.0# | 631 |

UPHOLSTERY INFORMATION

C.O.M. Upholstery

C.O.M. requirement for 10 chairs or less with upholstered seat or upholstered seat and back is 3/4 yard per chair of 54" wide nondirectional fabric. For orders of 11 or more with upholstered seat and back and for complete information on ordering C.O.M. see "Ordering C.O.M., C.O.V. and C.O.L." section.

OPTIONS

California TB133 Fire Safety Code

The above seating products can be manufactured using the appropriate flame-retardant materials for compliance to California Technical Bulletin 133.

Model=Polypropylene
 Added List Price=\$10

Model=Upholstered Seat
 Added List Price=\$73

Model=Upholstered Seat and Back
 Added List Price=\$104

SPECIAL SERVICES

Special Carton Marking

With specially marked information N/C

Shipping

Ships **assembled, FOB Green Bay, WI 54302, freight prepaid.** Freight class 125.

Specifications and prices are subject to change without prior notice.

Stack/Nesting

Strive® High Density Stack Chair General Information



Wire Rod High Density Stacking Chair (SWNA)



Wire Rod High Density Stacking Chair with Uph. Seat Pad (SWNAU)



Wire Rod High Density Stacking Chair with Tablet Arm (SWTAR)



Transport Dolly (CSD.BL)

| Features | | | | |
|--------------------------------|-----------------------|--------------------|---------|---------|
| Stackable | • | • | | |
| Poly or upholstered seat | • | • | • | |
| Flex back | • | • | • | |
| General Dimensions | | | | |
| Seat width | 17-3/4" | 17-3/4" | 17-3/4" | |
| Seat depth | 18-1/2" | 18-1/2" | 18-1/2" | |
| Seat height | 18" | 18" | 18" | |
| Tablet to chair back clearance | | | 15-1/4" | |
| Overall Dimensions | | | | |
| Width | 19-1/2" | 19-1/2" | 19-1/2" | 22-3/8" |
| Depth | 22-1/4" | 22-1/4" | 22-1/4" | 25-5/8" |
| Height | 32-1/2" | 32-1/2" | 32-1/2" | |
| Stacking on Dolly | | | | |
| Overall width | 22-1/2" | 23" | | |
| Overall depth | 45" | 39" | | |
| Quantity/height | 30 Chairs/77" High | 15 Chairs/65" High | | |
| Stacking on Floor | | | | |
| Width | 19-1/2" | 19-1/2" | | |
| Depth | 29-1/2" | 30" | | |
| Quantity/height | 6 Chairs/37-1/2" High | 5 Chairs/41" High | | |

SPECIFICATIONS

Seat

Injection molded polypropylene.

Backrest

Injection molded polypropylene with integral steel cantilever springs. The combination of the slotted polypropylene back and the spring steel provides a supportive flexing back. Springs are nominal 4.5mm diameter chrome silicon valve spring wire. Top of back has an integral handle for ease of lifting and stacking.

Chair Frame

7/16" solid steel rod in bright nickel-chrome or with electrostatically-applied epoxy.

Bright Chrome Finish

Surfaces are duplex nickel-chrome plated in a twenty-one step process.

Powder-Coated Finish

Electrostatically-applied epoxy baked onto surface.

Optional Upholstered Seat

Molded urethane foam is attached to an injection molded polypropylene seat board, then upholstered using a draw-string process. The assembled seat pad is attached to the seat by means of hidden fasteners.

Tablet Arm

7/16" solid steel rod frame, hinged tablet for easy access. Tablet is plywood core; high pressure laminate surface. Round tablet edge with clear lacquer finish. Bright chrome frame only. Chairs are nonstacking when attached, not available for use with powder coated frame chairs. Tablet flips up for easy access. Ganging with tablet is not recommended.

Stacking Vinyl, Polyurethane, and Imitation Leather Upholstered Chairs

It is recommended that chairs to be stacked be covered in material other than vinyl, polyurethane, or imitation leather as an impression in the seat may result. KI does not warrant the effects of stacking on stock

or C.O.M. vinyl, polyurethane, or imitation leather upholstery.

Transport Dolly

Tubular and plate steel welded together. 5" casters: two fixed, two swivel. Powder-coated finish.



INFORMATION

C.O.M. Testing and Production Requirements

Not all materials are suitable for upholstering this product. A 1 yd. x 54" sample must be submitted and approved prior to acceptance of an order. If the fabric is directional in pattern or weave, the direction must be indicated on the submitted sample, and additional yardage may be requested.

Test samples must be sent to:

KI
Attn: C.O.M. Specialist
1687 Westminster Drive - Gate 3
Green Bay, WI 54302

Fabric Disclaimer

Fabric will be applied as swatched by the fabric manufacturer. Fabric that is required to be applied differently than is swatched will need a Special Cost Request written specifying the direction the fabric is to be applied. The posted standard lead time will apply to the Special Cost Request.

Design

Designed by Giancarlo Piretti and manufactured in the USA by Krueger International, Inc. under license from Pro-Cord S.p.A

INFORMATION

Warranty

Refer to KI Terms & Conditions document or visit ki.com

Stack/Nesting

Strive® High Density Color Options

Frame Color

| | |
|---------------------------|----|
| Antique Vein | AV |
| Black | BL |
| Blue Grey | GR |
| Bronze Metallic | ZM |
| Cayenne | CY |
| Champagne Metallic | CM |
| Chocolate | CT |
| Chrome | CH |
| Cool Grey | CG |
| Cottonwood | CO |
| Espresso Metallic | EX |
| Flannel | FN |
| Grass Green | GN |
| Light Tone | LG |
| Mardi Gras | MG |
| Misty Brown | MY |
| Nemo | NE |
| Nickel Vein | NK |
| Nordic | ND |
| Poppy Red | PR |
| Purple Haze | PH |
| Rubber Ducky | RK |
| Sand | SA |
| Sky Blue | SK |
| Splash | SH |
| Starlight Silver Metallic | SX |
| Surf's Up | SP |
| Ultra Blue | UB |
| Warm Grey | WG |
| Wet Sand | WS |
| Zesty Lime | ZL |

Armcaps and glides match the frame color with the following exceptions:

-When frame color is chrome, metallic, or hammertone, the armcaps and glides will match poly color.

-When frame color is chrome, metallic, or hammertone, and the poly color is translucent diamond, the armcaps will be light tone.

-When frame color is chrome, metallic, or hammertone, and the poly color is translucent pewter, the armcaps will be flannel.

-When frame color is chrome, metallic, or hammertone, and the poly color is translucent bronze, the armcaps will be chocolate.

Casters for four-leg chairs are always black.

Seat and Back Color - Polypropylene Non Flame-Retardant

| | |
|--------------|-----|
| Black | PBL |
| Blue Grey | PGR |
| Cayenne | PCY |
| Chocolate | PCT |
| Cool Grey | PCG |
| Cottonwood | PCO |
| Flannel | PFN |
| Grass Green | PGN |
| Light Tone | PLG |
| Mardi Gras | PMG |
| Misty Brown | PMY |
| Nemo | PNE |
| Nordic | PND |
| Poppy Red | PPR |
| Purple Haze | PPH |
| Rubber Ducky | PRK |
| Sand | PSA |
| Sky Blue | PSK |
| Splash | PSH |
| Surf's Up | PSP |
| Ultra Blue | PUB |
| Warm Grey | PWG |
| Wet Sand | PWS |
| Zesty Lime | PZL |

Seat and Back Color - Polypropylene Flame-Retardant

| | |
|-------|-----|
| Black | PBL |
|-------|-----|

The above seating product can be manufactured using the appropriate flame-retardant materials for compliance to California Technical Bulletin 133.

TRANSLUCENT colors are available on the upholstered seat models only.

Tablet Arm Color - Laminate

| | |
|--------------------|-----|
| Biltmore Cherry | LBT |
| Black | LBK |
| Brighton Walnut | LBW |
| Canyon Zephyr | LCA |
| Castle Oak | LCO |
| Casual Linen | LCU |
| Cherry Storm | LCX |
| Classic Linen | LCI |
| Cloud Zephyr | LCL |
| Cocobala | LCC |
| Coffee Bean | LCB |
| Crisp Linen | LRI |
| Desert Zephyr | LDZ |
| Dove Grey | LDG |
| Fired Steel | LIL |
| Flax Linen | LXF |
| Florence Walnut | LFC |
| Forged Steel | LOL |
| Frosty White | LFW |
| Graphite Nebula | LGN |
| Grey | LGE |
| High Rise | LHE |
| Hollyberry | LHY |
| Irish Linen | LIH |
| Island | LID |
| Italian Silver Ash | LIT |
| Kensington Maple | LKM |
| Lapis Blue | LLB |
| Markerboard White | LMK |
| Misted Zephyr | LMR |
| Monticello Maple | LMT |
| Nickel Evolv | LNV |
| North Sea | LNA |
| Ocean | LON |
| Orange Grove | LOE |
| Pearl Bisque | LPB |
| Pearl Silver | LPS |
| Pressed Linen | LPR |
| River Cherry | LRY |
| Rugged Linen | LRG |
| Satin Stainless | LSS |
| Shadow Zephyr | LSR |
| Silicon evolv | LSV |
| Sterling Ash | LAZ |
| Tailored Linen | LTL |
| Titanium evolv | LTV |
| White Nebula | LWL |
| White Sand | LWN |
| Windsor Mahogany | LWY |

Finish Cards

View color swatches for items listed within this document.

Paints

Wood/Veneer

Molded Edges

Hard Plastics

Plastics/Poly

Laminates

Edge Styles

Glass



Stack/Nesting

Strive® High Density Stack Chair

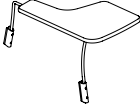
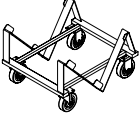
| | MODEL | Features | MODEL NUMBER | | | | | | | |
|---|--|------------------|--------------|--------------------------|--------------------------|--------------------------|--------------------------|--------------------------|--------------------------|--------------------------|
| | | | Basic Model | Frame Color | Seat & Back Color | Upholstery Color | Glide Option | Fire Code | Tablet Arm Color | |
|  SWSCP SWSCU | Armless Chair • Flex back | Polypropylene | SWNA | <input type="checkbox"/> | <input type="checkbox"/> | | | <input type="checkbox"/> | <input type="checkbox"/> | |
| | | Upholstered Seat | SWNAU | <input type="checkbox"/> | <input type="checkbox"/> | <input type="checkbox"/> | <input type="checkbox"/> | <input type="checkbox"/> | <input type="checkbox"/> | <input type="checkbox"/> |
|  SWTA | Standard Flip-Up Tablet Arm • NONSTACKING • 12" wide x 20-1/2" deep • Field installable • For use only on chrome framed chairs | Left Hand | SWTAL | | | | | | <input type="checkbox"/> | <input type="checkbox"/> |
| | | Right Hand | SWTAR | | | | | | <input type="checkbox"/> | <input type="checkbox"/> |
|  HRDPT | Transport Dolly • Accommodates up to 30 chairs (poly) and 15 chairs (upholstered) • Easy maneuverability with 5" casters: two fixed, two swivel • Black powder-coated finish | | CSD.BL | | | | | | | |
| | | | | | | | | | | |
| | | | | A | B | C | D | E | F | G |

HOW TO ORDER

Indicate the following information on order form:

- Quantity of each item.
- Model number, including options. See "How To Build a Model Number".
- Any special service required.

Note: • The indicates that a choice is required.

- The absence of the indicates that no choice is required.
- Alpha-numeric characters in place of indicate that no other alternatives are available.

HOW TO BUILD A MODEL NUMBER

A Select basic model.

B Select frame color.
Refer to the **Product Color Options** page in this price list.

C Select seat and back color.
Refer to the **Product Color Options** page in this price list.

D Select upholstery grade/color.
Refer to ki.com/fabrics

- E** Select glide option.
- G** - Ganging polycarbonate glides; add \$5
 - GS** - Ganging steel glides; add \$5
 - NG** - No glides
 - H** - Polycarbonate glides; add \$5
 - NS** - PVC non-skid glides; add \$5
 - S** - Stainless steel glides; add \$5

F Select fire code.

- FR** - Compliance to TB 133
- NFR** - Compliance to TB 117-2013

G Select tablet arm color.
Refer to the **Product Color Options** page in this price list.



| Approx. Packaged Weight | Delivered Pricing Upholstered | Delivered Pricing Fabric Grade 1 & C.O.M. | Delivered Pricing Fabric Grade 2 | Delivered Pricing Fabric Grade 3 | Delivered Pricing Vinyl Group 2V | Delivered Pricing Pallas Fabric Group P0 | Delivered Pricing Pallas Fabric Group P1 | Delivered Pricing Pallas Fabric Group P2 | Delivered Pricing Pallas Fabric Group P3 | Delivered Pricing Pallas Fabric Group P4 |
|-------------------------|-------------------------------|---|----------------------------------|----------------------------------|----------------------------------|--|--|--|--|--|
| 17.0# | \$ 202 | | | | | | | | | |
| 17.0# | N/A | 269 | 300 | 311 | 311 | 310 | 349 | 372 | 395 | 414 |

| | |
|------|--------|
| 7.0# | \$ 197 |
| 7.0# | 197 |

| | |
|-------|--------|
| 30.0# | \$ 448 |
|-------|--------|

UPHOLSTERY INFORMATION

C.O.M. Upholstery

C.O.M. requirement for 10 chairs or less with upholstered seat or upholstered seat and back is 3/4 yard per chair of 54" wide nondirectional fabric. For orders of 11 or more with upholstered seat and back and for complete information on ordering C.O.M. see "Ordering C.O.M., C.O.V. and C.O.L." section.

OPTIONS

California TB133 Fire Safety Code

The above seating products can be manufactured using the appropriate flame-retardant materials for compliance to California Technical Bulletin 133. No additional lead time.

Model=Polypropylene
Added list price=\$10

Model=Upholstered Seat
Added list price=\$73

SPECIAL SERVICES

Special Carton Marking

With specially marked information N/C

Shipping

Ships **assembled, FOB Green Bay, WI 54302, freight prepaid.** Freight class 125.

Specifications and prices are subject to change without prior notice.

Stack/Nesting

Strive® High Density Stack Chair

| MODEL | Features | MODEL NUMBER | | | | | | |
|--|---|--------------|---|--|---|---|--|---|
| | | Basic Model | Frame Color | Seat & Back Color | Top Stitch Color | TB133 | Upholstery Color | Glide Option |
|  <p>SWSTS</p> | Armless Chair with Top Stitch on Seat • Flex back Upholstered Seat | SWNATSU | <input type="checkbox"/> <input type="checkbox"/> | <input type="checkbox"/> <input type="checkbox"/> <input type="checkbox"/> | <input type="checkbox"/> <input type="checkbox"/> <input type="checkbox"/> <input type="checkbox"/> | <input type="checkbox"/> <input type="checkbox"/> | <input type="checkbox"/> <input type="checkbox"/> <input type="checkbox"/> <input type="checkbox"/> <input type="checkbox"/> | <input type="checkbox"/> <input type="checkbox"/> |
| | | | | | | | | |
| | | | | | | | | |
| | | | | | | | | |
| | | | | | | | | |
| | | | | | | | | |

A **B** **C** **D** **E** **F** **G**

HOW TO ORDER

Indicate the following information on order form:

- Quantity of each item.
- Model number, including options. See "How To Build a Model Number".
- Any special service required.

Note: • The indicates that a choice is required.

- The absence of the indicates that no choice is required.
- Alpha-numeric characters in place of indicate that no other alternatives are available.

HOW TO BUILD A MODEL NUMBER

- A** Select basic model.
- B** Select frame color.
Refer to the **Product Color Options** page in this price list.
- C** Select seat and back color.
Refer to the **Product Color Options** page in this price list.
- D** Select top stitch color.

| | |
|-------------|---------|
| BLTS | - Black |
| WHTS | - White |
- E** Select fire code.

| | |
|------------|-----------------------------|
| FR | - Compliance to TB 133 |
| NFR | - Compliance to TB 117-2013 |
- F** Select upholstery grade/color.
Refer to ki.com/fabrics

G Select glide option.

- | | |
|-----------|---|
| G | - Ganging polycarbonate glides; add \$5 |
| GS | - Ganging steel glides; add \$5 |
| NG | - No glides |
| H | - Polycarbonate glides; add \$5 |
| NS | - PVC non-skid glides; add \$5 |
| S | - Stainless steel glides; add \$5 |



| Approx. Packaged Weight | Delivered Pricing Pallas Fabric Group P1 |
|-------------------------------|---|
| 17.0# | \$ 395 |

UPHOLSTERY INFORMATION

C.O.M. Upholstery

C.O.M. requirement for 10 chairs or less with upholstered seat or upholstered seat and back is 3/4 yard per chair of 54" wide nondirectional fabric. For orders of 11 or more with upholstered seat and back and for complete information on ordering C.O.M. see "Ordering C.O.M., C.O.V. and C.O.L." section.

OPTIONS

California TB133 Fire Safety Code

The above seating products can be manufactured using the appropriate flame-retardant materials for compliance to California Technical Bulletin 133. No additional lead time.

Model=Polypropylene
Added list price=\$10

Model=Upholstered Seat
Added list price=\$73

SPECIAL SERVICES

Special Carton Marking

With specially marked information N/C

Shipping

Ships **assembled, FOB Green Bay, WI 54302, freight prepaid.** Freight class 125.

Specifications and prices are subject to change without prior notice.

Stack/Nesting

Strive® Nesting General Information



**Cantilever Armchair
(SNCAU)**



**Armless Chair
(SNNAP)**



Tablet Arm Chair (SNTAURH)

Oversize Tablet Arm Chair

| Features | | | | |
|--|---------|---------|---------|---------|
| Poly or upholstered seat | • | • | • | • |
| Flex back | • | • | • | • |
| Flip-up seat | • | • | • | • |
| Integral handle | • | • | • | • |
| Nesting | • | • | • | • |
| General Dimensions | | | | |
| Seat width | 17" | 17" | 17" | 17" |
| Seat depth | 18" | 18" | 18" | 18" |
| Seat height (upholstered add 1") | 16-1/2" | 16-1/2" | 16-1/2" | 16-1/2" |
| Tablet to chair back clearance | | | 14" | 14" |
| Overall Dimensions | | | | |
| Width | 23" | 23" | 24" | 24" |
| Depth | 22-3/4" | 22-3/4" | 29" | 32" |
| Height | 33-3/4" | 33-3/4" | 33-3/4" | 33-3/4" |
| Top of arm to floor | 25-1/2" | | 28-1/4" | 28-1/4" |
| Nesting (two chairs) (upholstered add 1") | 28-1/2" | 28-1/2" | 34-3/4" | 37-3/4" |

Nesting - For each additional chair, add 5-3/4"
(upholstered add 1")

SPECIFICATIONS

Seat and Backrest

Seat is two-piece construction of injection-molded polypropylene, reinforced with internal steel channels and assembled using hidden fasteners. The seat is available in a poly version or upholstered. For the upholstered version, molded urethane foam (1" depth) is applied to the seat board. Fabric is then upholstered over the foam using a drawstring process.

Backrest is injection-molded polypropylene with integral steel cantilever springs. The combination of the slotted polypropylene back and the spring steel provides a supportive flexing back. Springs are nominal 4.5mm diameter chrome silicon valve spring wire. Backrest is available poly only. Backrest has an integral molded "handle."

Seat flips up to allow chairs to nest for storage and transport.

Seat assembly and backrest are field replaceable.

Frame

The legs are 1" 13-gauge high-strength steel tubing. All frame joints are welded.

Frame Finishes

Baked-on electrostatically-applied 45° gloss epoxy powder coating or bright nickel chrome plating.

Casters/Glides

Double wheels (60mm) of high-impact thermoplastic. High-impact plastic frame. Carpet and hard floor casters are always black. Bell glide (2" high) made of high-impact plastic also available, black only.

Arm

Optional fixed-position T-arms are available. Arm supports are a continuation of the frame crossmember tube with injection-molded polypropylene armcaps attached by screws.

Tablet Arm

An optional tablet arm is available on either the RH or LH side. When so equipped, the tablet arm support structure is a continuation of the frame crossmember tube. A formed steel hinge is welded to the top of the support structure and secured with screws to the underside of the writing surface. Writing surface for standard tablet is 9-1/2" x 20-3/4" x 12-1/2" and oversize tablet is 15-1/2" x 22-1/2" x 14" plywood core of 5/8" thick, 11-ply hardwood surfaced with .030" high-pressure laminate top and plain backer undersurface. Tablet arm flips up for easy access. Edges are lacquered and sealed.



INFORMATION

C.O.M Testing and Production Requirements

Not all materials are suitable for upholstering this product. A 3/4 yd. x 54" sample must be submitted and approved prior to acceptance of an order. If the fabric is directional in pattern or weave, the direction must be indicated on the submitted sample, and additional yardage may be requested.

Test samples must be sent to:

KI
Attn: C.O.M. Specialist
1687 Westminster Drive - Gate 3
Green Bay, WI 54302

Fabric Disclaimer

Fabric will be applied as swatched by the fabric manufacturer. Fabric that is required to be applied differently than is swatched will need a Special Cost Request written specifying the direction the fabric is to be applied. The posted standard lead time will apply to the Special Cost Request.

INFORMATION

Warranty

Refer to KI Terms & Conditions document or visit ki.com

Stack/Nesting

Strive® Stack/Nesting Color Options

Frame Color

| | |
|---------------------------|----|
| Antique Vein | AV |
| Black | BL |
| Blue Grey | GR |
| Bronze Metallic | ZM |
| Cayenne | CY |
| Champagne Metallic | CM |
| Chocolate | CT |
| Chrome | CH |
| Cool Grey | CG |
| Cottonwood | CO |
| Espresso Metallic | EX |
| Flannel | FN |
| Grass Green | GN |
| Light Tone | LG |
| Mardi Gras | MG |
| Misty Brown | MY |
| Nemo | NE |
| Nickel Vein | NK |
| Nordic | ND |
| Poppy Red | PR |
| Purple Haze | PH |
| Rubber Ducky | RK |
| Sand | SA |
| Sky Blue | SK |
| Splash | SH |
| Starlight Silver Metallic | SX |
| Surf's Up | SP |
| Ultra Blue | UB |
| Warm Grey | WG |
| Wet Sand | WS |
| Zesty Lime | ZL |

Armcaps and glides match the frame color with the following exceptions:

-When frame color is chrome, metallic, or hammertone, the armcaps and glides will match poly color.

-When frame color is chrome, metallic, or hammertone, and the poly color is translucent diamond, the armcaps will be light tone.

-When frame color is chrome, metallic, or hammertone, and the poly color is translucent pewter, the armcaps will be flannel.

-When frame color is chrome, metallic, or hammertone, and the poly color is translucent bronze, the armcaps will be chocolate.

Casters for four-leg chairs are always black.

Seat and Back Color - Polypropylene Non Flame-Retardant

| | |
|--------------|-----|
| Black | PBL |
| Blue Grey | PGR |
| Cayenne | PCY |
| Chocolate | PCT |
| Cool Grey | PCG |
| Cottonwood | PCO |
| Flannel | PFN |
| Grass Green | PGN |
| Light Tone | PLG |
| Mardi Gras | PMG |
| Misty Brown | PMY |
| Nemo | PNE |
| Nordic | PND |
| Poppy Red | PPR |
| Purple Haze | PPH |
| Rubber Ducky | PRK |
| Sand | PSA |
| Sky Blue | PSK |
| Splash | PSH |
| Surf's Up | PSP |
| Ultra Blue | PUB |
| Warm Grey | PWG |
| Wet Sand | PWS |
| Zesty Lime | PZL |

Seat and Back Color - Polypropylene Flame-Retardant

| | |
|-------|-----|
| Black | PBL |
|-------|-----|

The above seating product can be manufactured using the appropriate flame-retardant materials for compliance to California Technical Bulletin 133.

TRANSLUCENT colors are available on the upholstered seat models only.

Tablet Arm Color - Laminate

| | |
|--------------------|-----|
| Biltmore Cherry | LBT |
| Black | LBK |
| Brighton Walnut | LBW |
| Canyon Zephyr | LCA |
| Castle Oak | LCO |
| Casual Linen | LCU |
| Cherry Storm | LCX |
| Classic Linen | LCI |
| Cloud Zephyr | LCL |
| Cocobala | LCC |
| Coffee Bean | LCB |
| Crisp Linen | LRI |
| Desert Zephyr | LDZ |
| Dove Grey | LDG |
| Fired Steel | LIL |
| Flax Linen | LXF |
| Florence Walnut | LFC |
| Forged Steel | LOL |
| Frosty White | LFW |
| Graphite Nebula | LGN |
| Grey | LGE |
| High Rise | LHE |
| Hollyberry | LHY |
| Irish Linen | LIH |
| Island | LID |
| Italian Silver Ash | LIT |
| Kensington Maple | LKM |
| Lapis Blue | LLB |
| Markerboard White | LMK |
| Misted Zephyr | LMR |
| Monticello Maple | LMT |
| Nickel Evolv | LNV |
| North Sea | LNA |
| Ocean | LON |
| Orange Grove | LOE |
| Pearl Bisque | LPB |
| Pearl Silver | LPS |
| Pressed Linen | LPR |
| River Cherry | LRY |
| Rugged Linen | LRG |
| Satin Stainless | LSS |
| Shadow Zephyr | LSR |
| Silicon evolv | LSV |
| Sterling Ash | LAZ |
| Tailored Linen | LTL |
| Titanium evolv | LTV |
| White Nebula | LWL |
| White Sand | LWN |
| Windsor Mahogany | LWY |

Finish Cards

View color swatches for items listed within this document.

Paints

Wood/Veneer

Molded Edges

Hard Plastics

Plastics/Poly

Laminates





Edge Styles

Glass



Stack/Nesting

Strive® Nesting Chairs

| MODEL | MODEL NUMBER | | | | | | Approx. Packaged Weight | Delivered Pricing |
|---|--------------|--------------------------|--------------------------|--------------------------|--------------------------|--------------------------|-------------------------|-------------------|
| | Basic Model | Frame Color | Poly Seat & Back Color | Base | Fire Code | Upholstery Color | | |
|  <p>Armless Chair with Poly Seat</p> <ul style="list-style-type: none"> • Flex back • Nests <p>SNP</p> | SNNAP | <input type="checkbox"/> | <input type="checkbox"/> | <input type="checkbox"/> | <input type="checkbox"/> | <input type="checkbox"/> | 23.0# | \$ 437 |
|  <p>Armless Chair with Upholstered Seat</p> <ul style="list-style-type: none"> • Flex back • Nests <p>SNU</p> | SNNAU | <input type="checkbox"/> | <input type="checkbox"/> | <input type="checkbox"/> | <input type="checkbox"/> | <input type="checkbox"/> | 23.0# | N/A |
|  <p>Armchair with Poly Seat</p> <ul style="list-style-type: none"> • Flex back • Nests <p>SNP</p> | SNCAP | <input type="checkbox"/> | <input type="checkbox"/> | <input type="checkbox"/> | <input type="checkbox"/> | <input type="checkbox"/> | 25.0# | \$ 496 |
|  <p>Armchair with Upholstered Seat</p> <ul style="list-style-type: none"> • Flex back • Nests <p>SNU</p> | SNCAU | <input type="checkbox"/> | <input type="checkbox"/> | <input type="checkbox"/> | <input type="checkbox"/> | <input type="checkbox"/> | 25.0# | N/A |

A **B** **C** **D** **E** **F**

HOW TO ORDER

Indicate the following information on order form:

1. Quantity of each item.
2. Model number, including options. See "How To Build a Model Number".
3. Any special service required.

Note: • The indicates that a choice is required.

- The absence of the indicates that no choice is required.
- Alpha-numeric characters in place of indicate that no other alternatives are available.

HOW TO BUILD A MODEL NUMBER

- A** Select basic model.
- B** Select frame color.
Refer to the **Product Color Options** page in this price list.
- C** Select poly seat and back color
Refer to the **Product Color Options** page in this price list.
- D** Select base option.

| | |
|----------|-----------------------------------|
| G | - Bell glides (black only) |
| C | - Carpet casters (black only) |
| S | - Hard floor casters (black only) |
- E** Select fire code.

| | |
|------------|-----------------------------|
| NFR | - Compliance to TB 117-2013 |
| FR | - Compliance to TB 133 |
- F** Select upholstery grade/color.
Refer to ki.com/fabrics



| Delivered Pricing Fabric Grade 1 & C.O.M. | Delivered Pricing Fabric Grade 2 | Delivered Pricing Fabric Grade 3 | Delivered Pricing C.O.V. | Delivered Pricing Vinyl Group 2V | Delivered Pricing Pallas Fabric Group P0 | Delivered Pricing Pallas Fabric Group P1 | Delivered Pricing Pallas Fabric Group P2 | Delivered Pricing Pallas Fabric Group P3 | Delivered Pricing Pallas Fabric Group P4 |
|---|----------------------------------|----------------------------------|--------------------------|----------------------------------|--|--|--|--|--|
| \$ 500 | \$ 528 | \$ 542 | \$ 500 | \$ 542 | \$ 540 | \$ 579 | \$ 599 | \$ 622 | \$ 640 |

| | | | | | | | | | |
|--------|--------|--------|--------|--------|--------|--------|--------|--------|--------|
| \$ 561 | \$ 588 | \$ 602 | \$ 561 | \$ 602 | \$ 598 | \$ 639 | \$ 658 | \$ 681 | \$ 700 |
|--------|--------|--------|--------|--------|--------|--------|--------|--------|--------|

UPHOLSTERY INFORMATION

C.O.M. Upholstery

C.O.M. requirement for 10 chairs or less with upholstered seat or upholstered seat and back is 3/4 yard per chair of 54" wide nondirectional fabric. For orders of 11 or more with upholstered seat and back and for complete information on ordering C.O.M. see "Ordering C.O.M., C.O.V. and C.O.L." section.

OPTIONS

California TB133 Fire Safety Code

The above seating products can be manufactured using the appropriate flame-retardant materials for compliance to California Technical Bulletin 133. No additional lead time.

Model=Polypropylene
Added list price=\$10

Model=Upholstered Seat
Added list price=\$73

SPECIAL SERVICES

Special Carton Marking

With specially marked information N/C



Shipping

Ships **assembled, FOB Green Bay, WI 54302, freight prepaid.** Freight class 125.

Specifications and prices are subject to change without prior notice.

Stack/Nesting

Strive® Nesting Chairs

| MODEL | Features | MODEL NUMBER | | | | | | |
|--|------------------|--------------|---|---|---|--------------------------|---|---|
| | | Basic Model | Frame Color | Poly Seat & Back Color | Top Stitch Color | Base | TB133 | Upholstery Color |
|  <p>Armless Chair with Upholstered Seat with Top Stitch on Seat</p> <ul style="list-style-type: none"> • Flex back • Nests <p>SNTS</p> | Upholstered Seat | SNNATSU | <input type="checkbox"/> <input type="checkbox"/> | <input type="checkbox"/> <input type="checkbox"/> <input type="checkbox"/> <input type="checkbox"/> | <input type="checkbox"/> <input type="checkbox"/> <input type="checkbox"/> <input type="checkbox"/> <input type="checkbox"/> <input type="checkbox"/> | <input type="checkbox"/> | <input type="checkbox"/> <input type="checkbox"/> <input type="checkbox"/> <input type="checkbox"/> | <input type="checkbox"/> <input type="checkbox"/> <input type="checkbox"/> <input type="checkbox"/> <input type="checkbox"/> <input type="checkbox"/> |
| | Upholstered Seat | | | | | | | |
| | Upholstered Seat | | | | | | | |
| | Upholstered Seat | | | | | | | |
|  <p>Armchair with Upholstered Seat with Top Stitch on Seat</p> <ul style="list-style-type: none"> • Flex back • Nests <p>SNTS</p> | Upholstered Seat | SNCATSU | <input type="checkbox"/> <input type="checkbox"/> | <input type="checkbox"/> <input type="checkbox"/> <input type="checkbox"/> <input type="checkbox"/> | <input type="checkbox"/> <input type="checkbox"/> <input type="checkbox"/> <input type="checkbox"/> <input type="checkbox"/> <input type="checkbox"/> | <input type="checkbox"/> | <input type="checkbox"/> <input type="checkbox"/> <input type="checkbox"/> <input type="checkbox"/> | <input type="checkbox"/> <input type="checkbox"/> <input type="checkbox"/> <input type="checkbox"/> <input type="checkbox"/> <input type="checkbox"/> |
| | Upholstered Seat | | | | | | | |
| | Upholstered Seat | | | | | | | |
| | Upholstered Seat | | | | | | | |

A **B** **C** **D** **E** **F** **G**

HOW TO ORDER

Indicate the following information on order form:

1. Quantity of each item.
2. Model number, including options. See "How To Build a Model Number".
3. Any special service required.

Note: • The indicates that a choice is required.

- The absence of the indicates that no choice is required.
- Alpha-numeric characters in place of indicate that no other alternatives are available.

HOW TO BUILD A MODEL NUMBER

G Select upholstery grade/color. Refer to ki.com/fabrics

- A** Select basic model.
- B** Select frame color. Refer to the **Product Color Options** page in this price list.
- C** Select poly seat and back color. Refer to the **Product Color Options** page in this price list.
- D** Select top stitch color.
 - BLTS** - Black
 - WHTS** - White
- E** Select base option.
 - G** - Bell glides (black only)
 - C** - Carpet casters (black only)
 - S** - Hard floor casters (black only)
- F** Select fire code.
 - NFR** - Compliance to TB 117-2013
 - FR** - Compliance to TB 133



| Approx. Packaged Weight | Delivered Pricing Pallas Fabric Group P1 |
|-------------------------------|---|
| 23.0# | \$ 622 |

| | |
|-------|--------|
| 25.0# | \$ 681 |
|-------|--------|

UPHOLSTERY INFORMATION

C.O.M. Upholstery

C.O.M. requirement for 10 chairs or less with upholstered seat or upholstered seat and back is 3/4 yard per chair of 54" wide nondirectional fabric. For orders of 11 or more with upholstered seat and back and for complete information on ordering C.O.M. see "Ordering C.O.M., C.O.V. and C.O.L." section.

OPTIONS

California TB133 Fire Safety Code

The above seating products can be manufactured using the appropriate flame-retardant materials for compliance to California Technical Bulletin 133. No additional lead time.

Model=Polypropylene
 Added list price=\$10

Model=Upholstered Seat
 Added list price=\$73

SPECIAL SERVICES

Special Carton Marking

With specially marked information N/C





Shipping

Ships **assembled, FOB Green Bay, WI 54302, freight prepaid.** Freight class 125.

Specifications and prices are subject to change without prior notice.

Stack/Nesting

Strive® Nesting Chairs

| MODEL | MODEL NUMBER | | | | | | | Approx. Packaged Weight |
|--|--------------|--------------------------|--------------------------|--------------------------|--------------------------|--------------------------|--------------------------|-------------------------|
| | Basic Model | Frame Color | Poly Seat & Back Color | Base | Tablet Arm Color | Fire Code | Upholstery Color | |
|  <p>Tablet Arm Chair with Poly Seat</p> <ul style="list-style-type: none"> • Flex back • Nests | SNTAPRH | <input type="checkbox"/> | <input type="checkbox"/> | <input type="checkbox"/> | <input type="checkbox"/> | <input type="checkbox"/> | | 28.0# |
| | SNTAPLH | <input type="checkbox"/> | <input type="checkbox"/> | <input type="checkbox"/> | <input type="checkbox"/> | <input type="checkbox"/> | | 28.0# |
| SNP | | | | | | | | |
|  <p>Tablet Arm Chair with Upholstered Seat</p> <ul style="list-style-type: none"> • Flex back • Nests | SNTAURH | <input type="checkbox"/> | <input type="checkbox"/> | <input type="checkbox"/> | <input type="checkbox"/> | <input type="checkbox"/> | <input type="checkbox"/> | 28.0# |
| | SNTAULH | <input type="checkbox"/> | <input type="checkbox"/> | <input type="checkbox"/> | <input type="checkbox"/> | <input type="checkbox"/> | <input type="checkbox"/> | 28.0# |
| SNU | | | | | | | | |
|  <p>Oversize Tablet Arm Chair with Poly Seat</p> <ul style="list-style-type: none"> • Flex back • Nests | SNOVTAPRH | <input type="checkbox"/> | <input type="checkbox"/> | <input type="checkbox"/> | <input type="checkbox"/> | <input type="checkbox"/> | | 28.0# |
| | SNOVTAPLH | <input type="checkbox"/> | <input type="checkbox"/> | <input type="checkbox"/> | <input type="checkbox"/> | <input type="checkbox"/> | | 28.0# |
| SNP | | | | | | | | |
|  <p>Oversize Tablet Arm Chair with Upholstered Seat</p> <ul style="list-style-type: none"> • Flex back • Nests | SNOVTAURH | <input type="checkbox"/> | <input type="checkbox"/> | <input type="checkbox"/> | <input type="checkbox"/> | <input type="checkbox"/> | <input type="checkbox"/> | 28.0# |
| | SNOVTAULH | <input type="checkbox"/> | <input type="checkbox"/> | <input type="checkbox"/> | <input type="checkbox"/> | <input type="checkbox"/> | <input type="checkbox"/> | 28.0# |
| SNU | | | | | | | | |

A **B** **C** **D** **E** **F** **G**

HOW TO ORDER

Indicate the following information on order form:

- Quantity of each item.
- Model number, including options. See "How To Build a Model Number".
- Any special service required.

Note: • The indicates that a choice is required.

- The absence of the indicates that no choice is required.
- Alpha-numeric characters in place of indicate that no other alternatives are available.

HOW TO BUILD A MODEL NUMBER

- A** Select basic model.
- B** Select frame color.
Refer to the **Product Color Options** page in this price list.
- C** Select poly seat and back color
Refer to the **Product Color Options** page in this price list.
- D** Select base option.

| | |
|----------|-----------------------------------|
| G | - Bell glides (black only) |
| C | - Carpet casters (black only) |
| S | - Hard floor casters (black only) |
- E** Select tablet arm color.
Refer to the **Product Color Options** page in this price list.
- F** Select fire code.

| | |
|------------|-----------------------------|
| NFR | - Compliance to TB 117-2013 |
| FR | - Compliance to TB 133 |

G Select upholstery grade/color.
Refer to ki.com/fabrics



| Delivered Pricing | Delivered Pricing Fabric Grade 1 & C.O.M. | Delivered Pricing Fabric Grade 2 | Delivered Pricing Fabric Grade 3 | Delivered Pricing C.O.V. | Delivered Pricing Vinyl Group 2V | Delivered Pricing Pallas Fabric Group P0 | Delivered Pricing Pallas Fabric Group P1 | Delivered Pricing Pallas Fabric Group P2 | Delivered Pricing Pallas Fabric Group P3 | Delivered Pricing Pallas Fabric Group P4 |
|-------------------|---|----------------------------------|----------------------------------|--------------------------|----------------------------------|--|--|--|--|--|
| \$ 622 | | | | | | | | | | |
| 622 | | | | | | | | | | |
| N/A | \$ 685 | \$ 713 | \$ 726 | \$ 685 | \$ 726 | \$ 725 | \$ 764 | \$ 783 | \$ 807 | \$ 825 |
| N/A | 685 | 713 | 726 | 685 | 726 | 725 | 764 | 783 | 807 | 825 |
| \$ 685 | | | | | | | | | | |
| 685 | | | | | | | | | | |
| N/A | \$ 749 | \$ 776 | \$ 790 | \$ 749 | \$ 790 | \$ 787 | \$ 827 | \$ 849 | \$ 870 | \$ 888 |
| N/A | 749 | 776 | 790 | 749 | 790 | 787 | 827 | 849 | 870 | 888 |

UPHOLSTERY INFORMATION

C.O.M. Upholstery

C.O.M. requirement for 10 chairs or less with upholstered seat or upholstered seat and back is 3/4 yard per chair of 54" wide nondirectional fabric. For orders of 11 or more with upholstered seat and back and for complete information on ordering C.O.M. see "Ordering C.O.M., C.O.V. and C.O.L." section.

OPTIONS

California TB133 Fire Safety Code

The above seating products can be manufactured using the appropriate flame-retardant materials for compliance to California Technical Bulletin 133. No additional lead time.

Model=Polypropylene
Added list price=\$10

Model=Upholstered Seat
Added list price=\$73

SPECIAL SERVICES

Special Carton Marking

With specially marked information N/C



Shipping

Ships **assembled, FOB Green Bay, WI 54302, freight prepaid.** Freight class 125.

Specifications and prices are subject to change without prior notice.

Stack/Nesting

Strive® Nesting Chairs

| Features | MODEL NUMBER | | | | | | | | Approx. Packaged Weight | |
|---|----------------------|-------------|--------------------------|--------------------------|--------------------------|--------------------------|--------------------------|--------------------------|-------------------------|----------|
| | Basic Model | Frame Color | Poly Seat & Back Color | Top Stitch Color | Base | Tablet Arm Color | TB133 | Upholstery Color | | |
|  <p>SNTS Tablet Arm Chair with Upholstered Seat with Top Stitch on Seat</p> <ul style="list-style-type: none"> Flex back Nests | Uph Seat, Left Hand | SNTATSULH | <input type="checkbox"/> | <input type="checkbox"/> | <input type="checkbox"/> | <input type="checkbox"/> | <input type="checkbox"/> | <input type="checkbox"/> | 28.0# | |
| | Uph Seat, Right Hand | SNTATSURH | <input type="checkbox"/> | <input type="checkbox"/> | <input type="checkbox"/> | <input type="checkbox"/> | <input type="checkbox"/> | <input type="checkbox"/> | 28.0# | |
|  <p>SNTS Oversize Tablet Arm Chair with Upholstered Seat with Top Stitch on Seat</p> <ul style="list-style-type: none"> Flex back Nests | Uph Seat, Left Hand | SNOVTATSULH | <input type="checkbox"/> | <input type="checkbox"/> | <input type="checkbox"/> | <input type="checkbox"/> | <input type="checkbox"/> | <input type="checkbox"/> | 28.0# | |
| | Uph Seat, Right Hand | SNOVTATSURH | <input type="checkbox"/> | <input type="checkbox"/> | <input type="checkbox"/> | <input type="checkbox"/> | <input type="checkbox"/> | <input type="checkbox"/> | 28.0# | |
| | | | A | B | C | D | E | F | G | H |

HOW TO ORDER

Indicate the following information on order form:

- Quantity of each item.
- Model number, including options. See "How To Build a Model Number".
- Any special service required.

Note: • The indicates that a choice is required.

- The absence of the indicates that no choice is required.
- Alpha-numeric characters in place of indicate that no other alternatives are available.

HOW TO BUILD A MODEL NUMBER

A Select basic model.

B Select frame color.
Refer to the **Product Color Options** page in this price list.

C Select poly seat and back color
Refer to the **Product Color Options** page in this price list.

D Select top stitch color.
BLTS - Black
WHTS - White

E Select base option.
G - Bell glides (black only)
C - Carpet casters (black only)
S - Hard floor casters (black only)

F Select tablet arm color.
Refer to the **Product Color Options** page in this price list.

G Select fire code.

NFR - Compliance to TB 117-2013
FR - Compliance to TB 133

H Select upholstery grade/color.
Refer to ki.com/fabrics

 Delivered
 Pricing
 Pallas Fabric
 Group P1

 \$ 807
 807

 \$ 870
 870

UPHOLSTERY INFORMATION
C.O.M. Upholstery

C.O.M. requirement for 10 chairs or less with upholstered seat or upholstered seat and back is 3/4 yard per chair of 54" wide nondirectional fabric. For orders of 11 or more with upholstered seat and back and for complete information on ordering C.O.M. see "Ordering C.O.M., C.O.V. and C.O.L." section.

OPTIONS
California TB133 Fire Safety Code

The above seating products can be manufactured using the appropriate flame-retardant materials for compliance to California Technical Bulletin 133. No additional lead time.

Model=Polypropylene
 Added list price=\$10

Model=Upholstered Seat
 Added list price=\$73

SPECIAL SERVICES
Special Carton Marking

With specially marked information N/C

Shipping

Ships **assembled, FOB Green Bay, WI 54302, freight prepaid.** Freight class 125.

Specifications and prices are subject to change without prior notice.

Stack/Nesting

Torsion® on the Go® General Information



**Upholstered Back Arm Chair
(TGWAUB)**



**Upholstered Back Armless Chair
(TGNAUB)**



**Poly Back Arm Chair
(TGWAPB)**

| Features | | | |
|---------------------------|-----------|-----------|-----------|
| Back flex | • | • | • |
| Flip-up seat | • | • | • |
| Nesting | • | • | • |
| Casters | • | • | • |
| General Dimensions | | | |
| Seat width | 17-1/4" | 17-1/4" | 17-1/4" |
| Seat depth | 18-1/2" | 18-1/2" | 18-1/2" |
| Seat height | 18" | 18" | 18" |
| Back width | 18-1/4" | 18-1/4" | 18-1/4" |
| Back height | 14" | 14" | 14" |
| Overall Dimensions | | | |
| Width | 23-1/2" | 23-1/2" | 23-1/2" |
| Depth | 24-1/4" | 24-1/4" | 24-1/4" |
| Height | 32-1/4" | 32-1/4" | 32-1/4" |
| Top of arm to floor | 24-1/4" | | 24-1/4" |
| Nesting (two chairs) | 24" x 24" | 24" x 24" | 24" x 24" |

(Each additional chair - add 5")



Arm



Caster

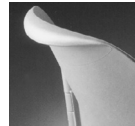

Back Handle

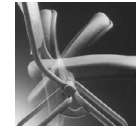

Flip-up Seat

SPECIFICATIONS

Seat and Backrest

Seat is two-piece construction of molded plywood upholstery board with a molded compound curved nylon shroud with a textured finish. Seat is always upholstered. Foam (1-3/4") is applied to the molded plywood upholstery board. Fabric is then upholstered over the foam. Backrest is available in either a polypropylene or upholstered version. Backrest is molded compound curved polypropylene with a textured finish. Backrest has an integral, molded "handle."

Back upholstery liner is molded polypropylene with glued-on foam (1/2"). Fabric is upholstered over the foam. The liner is secured to the backrest by four #10 color-matched machine screws.

Seat flips up to allow chairs to nest for storage and transport.

Backrest Supports

Two welded steel backrest supports attach the backrest to the torsion mechanism.

Torsion® Mechanism

The back flex is achieved by the torsion mechanism. It consists of two flat torsion springs captured at both ends by steel bushings that are welded to the backrest supports. The torsion mechanism creates gradually increasing resistance over the full 12° of back flex.

Frame

The frame is made up of four legs welded to a steel mechanism tube. The legs are 1", 13-gauge steel tubing. Reinforcement plates are welded between front and back legs for added strength. Nylon covers fit over the plates.

Casters/Glides

Double wheels (60mm) of high-impact thermoplastic. High-impact plastic frame. Carpet and hard floor casters are always

black. Bell glide (2" high) made of high-impact plastic also available, black only.

Leg Finishes

Baked-on electrostatically-applied epoxy powder coating or bright nickel-chrome plating.

Arms

Armrests are made of nylon and match the seat and back poly color. Armrests rotate with the back.

Tablet/Tablet Arm

The tablet is available in a plywood core (5/8" thick, 11-ply hardwood surfaced with .030" high-pressure laminate top and plain backer undersurface) or a black molded polyethylene. It is connected to the mechanism and supported by a 12-gauge steel plate. It has an effective working surface 12" deep by 22" across. The tablet arm is not field addable. The tablet arm is available in right-hand and left-hand versions. The tablet mechanism consists of aluminum die

cast housings and through bolted pivots with bushings on two axis. The mechanism allows for horizontal rotation for ingress/egress without stowing the tablet. The mechanism stows the tablet so that the chair will nest with other Torsion® on the Go!® chairs with tablets and Torsion® on the Go!® chairs without tablet or arms.



**Poly Back Armless Chair
(TGNAPB)**



**Poly Back Tablet Arm Chair
(TGTARPB)**

| Features | | |
|---------------------------|-----------|-----------|
| Back flex | • | • |
| Flip-up seat | • | • |
| Nesting | • | • |
| Casters | • | • |
| General Dimensions | | |
| Seat width | 17-1/4" | 17-1/4" |
| Seat depth | 18-1/2" | 18-1/2" |
| Seat height | 18" | 18" |
| Back width | 18-14" | 18-1/4" |
| Back height | 14" | 14" |
| Overall Dimensions | | |
| Width | 23-1/2" | 27" |
| Depth | 24-1/4" | 31" |
| Height | 32-1/4" | 32-1/4" |
| Top of arm to floor | | 29" |
| Nesting (two chairs) | 24" x 24" | 24" x 24" |

(Each additional chair - add 5")

INFORMATION

C.O.M. Testing and Production Requirements

Not all materials are suitable for upholstering this product. A 1 yd. x 54" sample must be submitted and approved prior to acceptance of an order. If the fabric is directional in pattern or weave, the direction must be indicated on the submitted sample, and additional yardage may be requested.

Test samples must be sent to:

KI
Attn: C.O.M. Specialist
1687 Westminster Drive - Gate 3
Green Bay, WI 54302

Fabric Disclaimer

Fabric will be applied as swatched by the fabric manufacturer. Fabric that is required to be applied differently than is swatched will need a Special Cost Request written specifying the direction the fabric is to be applied. The posted standard lead time will apply to the Special Cost Request.

Design

Designed by Giancarlo Piretti and manufactured in the USA by Krueger International, Inc. under license from Pro-Cord S.p.A.

INFORMATION

Warranty

Refer to KI Terms & Conditions document or visit ki.com

Stack/Nesting

Torsion on the Go® Color Options

Frame Color

| | |
|---------------------------|----|
| Antique Vein | AV |
| Black | BL |
| Blue Grey | GR |
| Bronze Metallic | ZM |
| Cayenne | CY |
| Champagne Metallic | CM |
| Chocolate | CT |
| Chrome | CH |
| Cool Grey | CG |
| Cottonwood | CO |
| Espresso Metallic | EX |
| Flannel | FN |
| Light Tone | LG |
| Mardi Gras | MG |
| Misty Brown | MY |
| Nemo | NE |
| Nickel Vein | NK |
| Nordic | ND |
| Purple Haze | PH |
| Rubber Ducky | RK |
| Sand | SA |
| Splash | SH |
| Starlight Silver Metallic | SX |
| Surf's Up | SP |
| Ultra Blue | UB |
| Warm Grey | WG |
| Wet Sand | WS |
| Zesty Lime | ZL |

Seat and Back Color - Polypropylene Non Flame-Retardant

| | |
|--------------|-----|
| Black | PBL |
| Blue Grey | PGR |
| Cool Grey | PCG |
| Cottonwood | PCO |
| Flannel | PFN |
| Light Tone | PLG |
| Mardi Gras | PMG |
| Misty Brown | PMY |
| Nemo | PNE |
| Nordic | PND |
| Purple Haze | PPH |
| Rubber Ducky | PRK |
| Sand | PSA |
| Surf's Up | PSP |
| Ultra Blue | PUB |
| Warm Grey | PWG |
| Wet Sand | PWS |
| Zesty Lime | PZL |

Seat and Back Color - Polypropylene Flame-Retardant

Black PBL

The above seating product can be manufactured using the appropriate flame-retardant materials for compliance to California Technical Bulletin 133.

TRANSLUCENT colors are available on the upholstered seat models only.

Tablet Arm Color - Polyethylene

Black BLWS

Tablet Arm Color - Laminate

| | |
|--------------------|------|
| Biltmore Cherry | LBT |
| Black | LBK |
| Brighton Walnut | LBW |
| Canyon Zephyr | LCA |
| Castle Oak | LCO |
| Casual Linen | LCU |
| Cherry Storm | L CX |
| Classic Linen | L CI |
| Cloud Zephyr | L CL |
| Cocobala | L CC |
| Coffee Bean | L CB |
| Crisp Linen | L RI |
| Desert Zephyr | L DZ |
| Dove Grey | L DG |
| Fired Steel | L IL |
| Flax Linen | L XF |
| Florence Walnut | L FC |
| Forged Steel | L OL |
| Frosty White | L FW |
| Graphite Nebula | L GN |
| Grey | L GE |
| High Rise | L HE |
| Hollyberry | L HY |
| Irish Linen | L IH |
| Island | L ID |
| Italian Silver Ash | L IT |
| Kensington Maple | L KM |
| Lapis Blue | L LB |
| Markerboard White | L MK |
| Misted Zephyr | L MR |
| Monticello Maple | L MT |
| Nickel Evolv | L NV |
| North Sea | L NA |
| Ocean | L ON |
| Orange Grove | L OE |
| Pearl Bisque | L PB |
| Pearl Silver | L PS |
| Pressed Linen | L PR |
| River Cherry | L RY |
| Rugged Linen | L RG |
| Satin Stainless | L SS |
| Shadow Zephyr | L SR |
| Silicon evolv | L SV |
| Sterling Ash | L AZ |
| Tailored Linen | L TL |
| Titanium evolv | L TV |
| White Nebula | L WL |
| White Sand | L WN |
| Windsor Mahogany | L WY |

When frame color is CH, AV, or NK the back support matches seat and back color.

Finish Cards

View color swatches for items listed within this document.

Paints

Plastics/Poly

Wood/Veneer

Laminates

Molded Edges

Edge Styles





Hard Plastics

Glass



Stack/Nesting

Torsion® on the Go® Nesting Chairs

| | MODEL | MODEL NUMBER | | | | | Approx. Packaged Weight | Delivered Pricing Fabric Grade 1 & C.O.M. |
|---|--------|--------------------------|--------------------------|--------------------------|--------------------------|--------------------------|-------------------------|---|
| | | Basic Model | Frame Color | Seat/Back/Armrest Color | Base | Upholstery Color | | |
|  <p>Armless Chair with Poly Back</p> <ul style="list-style-type: none"> • Flex back • Flip-up seat • Nests • Casters or glides | TGNAPB | <input type="checkbox"/> | <input type="checkbox"/> | <input type="checkbox"/> | <input type="checkbox"/> | <input type="checkbox"/> | 32.0# | \$ 682 |
| TGU | | | | | | | | |
|  <p>Armless Chair with Upholstered Back</p> <ul style="list-style-type: none"> • Flex back • Flip-up seat • Nests • Casters or glides | TGNAUB | <input type="checkbox"/> | <input type="checkbox"/> | <input type="checkbox"/> | <input type="checkbox"/> | <input type="checkbox"/> | 33.0# | \$ 729 |
| TGU | | | | | | | | |
|  <p>Arm Chair with Poly Back</p> <ul style="list-style-type: none"> • Flex back • Flip-up seat • Nests • Casters or glides • Armrest color matches seat/back poly color | TGWAPB | <input type="checkbox"/> | <input type="checkbox"/> | <input type="checkbox"/> | <input type="checkbox"/> | <input type="checkbox"/> | 33.0# | \$ 713 |
| TGU | | | | | | | | |
|  <p>Arm Chair with Upholstered Back</p> <ul style="list-style-type: none"> • Flex back • Flip-up seat • Nests • Casters or glides • Poly Armrests | TGWAUB | <input type="checkbox"/> | <input type="checkbox"/> | <input type="checkbox"/> | <input type="checkbox"/> | <input type="checkbox"/> | 35.0# | \$ 759 |
| TGU | | | | | | | | |

A **B** **C** **D** **E**

HOW TO ORDER

Indicate the following information on order form:

1. Quantity of each item.
2. Model number, including options. See "How To Build a Model Number".
3. Any special service required.

Note: • The indicates that a choice is required.

- The absence of the indicates that no choice is required.
- Alpha-numeric characters in place of indicate that no other alternatives are available.

HOW TO BUILD A MODEL NUMBER

- A** Select basic model.
- B** Select frame color.
Refer to the **Product Color Options** page in this price list.
The metal back support matches the frame color.
- C** Select seat and back color.
Refer to the **Product Color Options** page in this price list.
Armrest color will match seat/back poly color.
- D** Select base option.

| | |
|----------|-----------------------------------|
| G | - Bell glides (black only) |
| C | - Carpet casters (black only) |
| S | - Hard floor casters (black only) |
- E** Select upholstery grade/color.
Refer to ki.com/fabrics

F Select fire code.

| | |
|------------|-----------------------------|
| NFR | - Compliance to TB 117-2013 |
| FR | - Compliance to TB 133 |



| Delivered Pricing Fabric Grade 2 | Delivered Pricing Fabric Grade 3 | Delivered Pricing Vinyl Group 2V | Delivered Pricing Pallas Fabric Group P0 | Delivered Pricing Pallas Fabric Group P1 | Delivered Pricing Pallas Fabric Group P2 | Delivered Pricing Pallas Fabric Group P3 | Delivered Pricing Pallas Fabric Group P4 |
|--|--|--|--|--|--|--|--|
| \$ 697 | \$ 713 | \$ 713 | \$ 708 | \$ 719 | \$ 755 | \$ 782 | \$ 814 |
| \$ 745 | \$ 760 | \$ 760 | \$ 755 | \$ 766 | \$ 801 | \$ 828 | \$ 862 |
| \$ 729 | \$ 744 | \$ 744 | \$ 739 | \$ 751 | \$ 779 | \$ 812 | \$ 842 |
| \$ 774 | \$ 789 | \$ 789 | \$ 787 | \$ 799 | \$ 828 | \$ 859 | \$ 889 |

UPHOLSTERY INFORMATION

C.O.M. Upholstery

C.O.M. requirement for 10 chairs either poly or upholstered is 3/4 yard of 54" wide nondirectional fabric. For orders of 11 of more chairs and for complete information on ordering C.O.M., see "Ordering C.O.M., C.O.V. and C.O.L." section.

OPTIONS

California TB133 Fire Safety Code

For California Technical Bulletin 133 compliant models, add the following upcharge:
 Model=Polypropylene Back
 Added Lead Time=1 week
 Added list price=\$52
 Model=Upholstered Seat/Back
 Added Lead Time=1 week
 Added list price=\$80

SPECIAL SERVICES

Special Carton Marking

With specially marked information N/C



Shipping

Ships **assembled, FOB Green Bay, WI 54302, freight prepaid.** Freight class 125.

Specifications and prices are subject to change without prior notice.

Stack/Nesting

Torsion® on the Go® Nesting Chairs

| | MODEL | Features | MODEL NUMBER | | | | | | | Approx. Packaged Weight | | |
|---|---|---|--------------|--------------|--------------------------|--------------------------|------------------------------|--------------------------|--------------------------|--------------------------|--------------------------|--------------------------|
| | | | Basic Model | Surface Type | Frame Color | Seat & Back Color | Surface Finish/Plastic Color | Base | Upholstery Color | | | |
|  | Tablet Arm Chair with Poly Back | <ul style="list-style-type: none"> • Flex back • Flip-up seat • Nests • Casters or glides • The tablet is available in right-hand and left-hand versions | Left Hand | TGTALPB | <input type="checkbox"/> | <input type="checkbox"/> | <input type="checkbox"/> | <input type="checkbox"/> | <input type="checkbox"/> | <input type="checkbox"/> | <input type="checkbox"/> | 30.0# |
| | | | Right Hand | TGTARPB | <input type="checkbox"/> | <input type="checkbox"/> | <input type="checkbox"/> | <input type="checkbox"/> | <input type="checkbox"/> | <input type="checkbox"/> | <input type="checkbox"/> | <input type="checkbox"/> |
| TGU | | | | | | | | | | | | |
|  | Tablet Arm Chair with Upholstered Back | <ul style="list-style-type: none"> • Flex back • Flip-up seat • Nests • Casters or glides • The tablet is available in right-hand and left-hand versions | Left Hand | TGTALUB | <input type="checkbox"/> | <input type="checkbox"/> | <input type="checkbox"/> | <input type="checkbox"/> | <input type="checkbox"/> | <input type="checkbox"/> | <input type="checkbox"/> | 31.0# |
| | | | Right Hand | TGTARUB | <input type="checkbox"/> | <input type="checkbox"/> | <input type="checkbox"/> | <input type="checkbox"/> | <input type="checkbox"/> | <input type="checkbox"/> | <input type="checkbox"/> | <input type="checkbox"/> |
| TGU | | | | | | | | | | | | |

A **B** **C** **D** **E** **F** **G**

HOW TO ORDER

Indicate the following information on order form:

1. Quantity of each item.
2. Model number, including options. See "How To Build a Model Number".
3. Any special service required.

Note: • The indicates that a choice is required.

- The absence of the indicates that no choice is required.
- Alpha-numeric characters in place of indicate that no other alternatives are available.

HOW TO BUILD A MODEL NUMBER

A Select basic model.

- B** Select worksurface type.
- LW** - Laminate worksurface; add \$60
 - PW** - Plastic worksurface

C Select frame color. Refer to the **Product Color Options** page in this price list.

D Select seat and back color. Refer to the **Product Color Options** page in this price list. Armrest color will match seat/back poly color.

E Select surface finish. Refer to the **Product Color Options** page in this price list.

F Select base option.

- G** - Bell glides (black only)
- C** - Carpet casters (black only)
- S** - Hard floor casters (black only)

G Select upholstery grade/color. Refer to ki.com/fabrics



| Delivered Pricing Fabric Grade 1 & C.O.M. | Delivered Pricing Fabric Grade 2 | Delivered Pricing Fabric Grade 3 | Delivered Pricing Vinyl Group 2V | Delivered Pricing Pallas Fabric Group P0 | Delivered Pricing Pallas Fabric Group P1 | Delivered Pricing Pallas Fabric Group P2 | Delivered Pricing Pallas Fabric Group P3 | Delivered Pricing Pallas Fabric Group P4 |
|---|--|--|--|--|--|--|--|--|
| \$ 1012 | \$ 1025 | \$ 1043 | \$ 1043 | \$ 1039 | \$ 1050 | \$ 1085 | \$ 1113 | \$ 1145 |
| 1012 | 1025 | 1043 | 1043 | 1039 | 1050 | 1085 | 1113 | 1145 |

| | | | | | | | | |
|---------|---------|---------|---------|---------|---------|---------|---------|---------|
| \$ 1058 | \$ 1072 | \$ 1089 | \$ 1089 | \$ 1083 | \$ 1096 | \$ 1129 | \$ 1156 | \$ 1190 |
| 1058 | 1072 | 1089 | 1089 | 1083 | 1096 | 1129 | 1156 | 1190 |

UPHOLSTERY INFORMATION

C.O.M. Upholstery

C.O.M. requirement for 10 chairs either poly or upholstered is 3/4 yard of 54" wide nondirectional fabric. For orders of 11 or more chairs and for complete information on ordering C.O.M., see "Ordering C.O.M., C.O.V. and C.O.L." section.

SPECIAL SERVICES

Special Carton Marking

With specially marked information N/C

Shipping

Ships **assembled, FOB Green Bay, WI 54302, freight prepaid.** Freight class 125.

Specifications and prices are subject to change without prior notice.

Stack/Nesting

Torsion® General Information



**Full Sled Base Chair
(TSNAU)**



**Four-Leg Arm Chair
(TLFAU)**



**Transport Dolly
(TVD and TLD Dolly)**

Features

Stackable

•

•

General Dimensions

Seat width

18"

18"

Seat depth

18"

18"

Seat height

17-3/8"

17-7/8"

Back width

17-7/8"

17-7/8"

Back height

15-1/4"

15-1/4"

Overall Dimensions

Width

21" No Arm

20" No Arm/24" Arm

22-1/2"

Depth

22-3/4"

23-1/4"

25-1/2"

Height

32-3/4"

32-3/4"

12"

Top of arm to floor

25-5/8"

Stacking on Dolly

Quantity/height

6 Chairs/50" High No Arm

5 Chairs/52" High No Arm & Arm

Floor space (no arms)

21" x 29"

24" x 32"

Floor space (arms)

25" x 32"

Stacking on Floor

Quantity/height

5 Chairs/44" High No Arm

5 Chairs/47" High No Arm & Arm

Floor space (no arms)

21" x 28"

20" x 30"

Floor space (arms)

24" x 30"

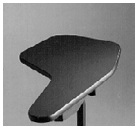

Standard Flip-Up Tablet Arm



G2-Tablet Arm (Down)
(only on TS and TL frames)



G2-Tablet Arm (Up)
(only on TS and TL frames)



Cantilevered Arm

SPECIFICATIONS

Seat and Backrest

Seats and backrests are molded compound curved polypropylene with a textured finish. Seat is two-piece construction. Upholstered chairs have partially exposed polypropylene surfaces. Fabric is upholstered over 9/16" foam on the backrest and 5/16" foam on the seat.

Backrest Supports

Two die-cast aluminum backrest supports attach the backrest to the Torsion® mechanism. A steel tube is cast into each backrest support for added strength.

Torsion® Mechanism

The back flex is achieved by the Torsion® mechanism. It consists of two flat torsion springs captured at both ends by steel bushings which in turn engage with the backrest supports. The Torsion® mechanism creates gradually-increasing resistance over the full 12° of back flex.

Full Sled Base Frame (TS)

The sled base frame consists of two segments of 3/4", 16-gauge seam-welded tubular steel and two steel seat supports.

Four-Leg Frame (TL)

The four-leg frame consists of two U-shaped sections, one front and one rear, welded together with two support brackets to form the four-leg chair. The sections are formed of 15/16", 15-gauge seam-welded tubular steel.

Leg Finishes

Baked-on, electrostatically-applied epoxy powder coating, or bright nickel-chrome plating.

Cantilevered Arm (TS, TL Chairs)

Fiberglass-reinforced nylon. Arms flex with the back. Available in black only. Not field-installable.

Standard Flip-Up Tablet Arm

Plywood core tablet with high-pressure laminate surface. The edge is black laminate, otherwise clear lacquer. Tablet arm support matches frame color. Tablet is 19-1/2" long and 12-3/4" wide.

Fold-Down, G2-Tablet Arm

Only available on TS and TL frames. Tablet is constructed of plywood core with high-pressure laminate surface and a clear lacquered edge. Tablet arm support matches frame color (hinge is always black). The tablet is 18" long and 13-3/4" wide. 4" of clearance is needed behind chair to allow table to fold away. Nonstacking.

Stacking Vinyl, Polyurethane, and Imitation Leather Upholstered Chairs

It is recommended that chairs to be stacked be covered in material other than vinyl, polyurethane, or imitation leather as an impression in the seat may result. KI does not warrant the effects of stacking on stock or C.O.M. vinyl, polyurethane, or imitation leather upholstery.

Transport Dolly

Tubular and plate steel welded together. 5" casters: two fixed, two swivel. Powder-coated finish.



**Full Sled Base G2-Tablet
Arm Chair (TSG2ARU)**

**Four-Leg Tablet Arm Chair
25-5/8"**

Features

Stackable

General Dimensions

| | | |
|---------------------------|---------|-----------------------|
| Seat width | 18" | 18" |
| Seat depth | 18" | 18" |
| Seat height | 17-3/8" | 17-3/8" |
| Back width | 17-7/8" | 17-7/8" |
| Back height | 15-1/4" | 15-1/4" |
| Overall Dimensions | | |
| Width | 21" | 21" |
| Depth | 22-3/4" | 22-3/4" |
| Height | 32-3/4" | 32-3/4" |
| Top of arm to floor | 25-5/8" | 25-5/8" |
| Stacking on Floor | | |
| Quantity/height | | 4 Chairs/47-1/2" High |
| Floor space (arms) | | 28-1/2" x 35-1/2" |

INFORMATION

C.O.M Testing and Production Requirements

Not all materials are suitable for upholstering this product. A 3/4 yd. x 54" sample must be submitted and approved prior to acceptance of an order. If the fabric is directional in pattern or weave, the direction must be indicated on the submitted sample, and additional yardage may be requested.

Test samples must be sent to:

KI
Attn: C.O.M. Specialist
1687 Westminster Drive - Gate 3
Green Bay, WI 54302

Fabric Disclaimer

Fabric will be applied as swatched by the fabric manufacturer. Fabric that is required to be applied differently than is swatched will need a Special Cost Request written specifying the direction the fabric is to be applied. The posted standard lead time will apply to the Special Cost Request.

Design

Designed by Giancarlo Piretti and manufactured in the USA by Krueger International, Inc. under license from Pro-Cord S.p.A.

INFORMATION

Warranty

Refer to KI Terms & Conditions document or visit ki.com

Stack/Nesting

Torsion® Color Options

Frame Color

| | |
|---------------------------|----|
| Antique Vein | AV |
| Black | BL |
| Blue Grey | GR |
| Bronze Metallic | ZM |
| Cayenne | CY |
| Champagne Metallic | CM |
| Chocolate | CT |
| Chrome | CH |
| Cool Grey | CG |
| Cottonwood | CO |
| Espresso Metallic | EX |
| Flannel | FN |
| Light Tone | LG |
| Mardi Gras | MG |
| Misty Brown | MY |
| Nemo | NE |
| Nickel Vein | NK |
| Nordic | ND |
| Purple Haze | PH |
| Rubber Ducky | RK |
| Sand | SA |
| Splash | SH |
| Starlight Silver Metallic | SX |
| Surf's Up | SP |
| Ultra Blue | UB |
| Warm Grey | WG |
| Wet Sand | WS |
| Zesty Lime | ZL |

Seat and Back Color - Polypropylene Non Flame-Retardant

| | |
|--------------|-----|
| Black | PBL |
| Blue Grey | PGR |
| Cool Grey | PCG |
| Cottonwood | PCO |
| Flannel | PFN |
| Light Tone | PLG |
| Mardi Gras | PMG |
| Misty Brown | PMY |
| Nemo | PNE |
| Nordic | PND |
| Purple Haze | PPH |
| Rubber Ducky | PRK |
| Sand | PSA |
| Surf's Up | PSP |
| Ultra Blue | PUB |
| Warm Grey | PWG |
| Wet Sand | PWS |
| Zesty Lime | PZL |

Seat and Back Color - Polypropylene Flame-Retardant

| | |
|-------|-----|
| Black | PBL |
|-------|-----|

The above seating product can be manufactured using the appropriate flame-retardant materials for compliance to California Technical Bulletin 133.

TRANSLUCENT colors are available on the upholstered seat models only.

Armrest Color

| | |
|-------|-----|
| Black | ABL |
|-------|-----|

Tablet Arm Color - Laminate

| | |
|--------------------|-----|
| Biltmore Cherry | LBT |
| Black | LBK |
| Brighton Walnut | LBW |
| Canyon Zephyr | LCA |
| Castle Oak | LCO |
| Casual Linen | LCU |
| Cherry Storm | LCX |
| Classic Linen | LCI |
| Cloud Zephyr | LCL |
| Cocobala | LCC |
| Coffee Bean | LCB |
| Crisp Linen | LRI |
| Desert Zephyr | LDZ |
| Dove Grey | LDG |
| Fired Steel | LIL |
| Flax Linen | LXF |
| Florence Walnut | LFC |
| Forged Steel | LOL |
| Frosty White | LFW |
| Graphite Nebula | LGN |
| Grey | LGE |
| High Rise | LHE |
| Hollyberry | LHY |
| Irish Linen | LIH |
| Island | LID |
| Italian Silver Ash | LIT |
| Kensington Maple | LKM |
| Lapis Blue | LLB |
| Markerboard White | LMK |
| Misted Zephyr | LMR |
| Monticello Maple | LMT |
| Nickel Evolv | LNV |
| North Sea | LNA |
| Ocean | LON |
| Orange Grove | LOE |
| Pearl Bisque | LPB |
| Pearl Silver | LPS |
| Pressed Linen | LPR |
| River Cherry | LRY |
| Rugged Linen | LRG |
| Satin Stainless | LSS |
| Shadow Zephyr | LSR |
| Silicon evolv | LSV |
| Sterling Ash | LAZ |
| Tailored Linen | LTL |
| Titanium evolv | LTV |
| White Nebula | LWL |
| White Sand | LWN |
| Windsor Mahogany | LWY |

Chrome NOT available on chairs with G-tablet arms.

When frame color is CH, AV, or NK the back support matches seat and back color.

Finish Cards

View color swatches for items listed within this document.

Paints

Plastics/Poly

Wood/Veneer

Laminates

Molded Edges

Edge Styles



Hard Plastics

Glass



Stack/Nesting

Torsion®

| | MODEL | Features | MODEL NUMBER | | | | | | | Approx. Packaged Weight |
|---|--|---------------|--------------|--------------------------|--------------------------|--------------------------|--------------------------|--------------------------|--------------------------|-------------------------|
| | | | Basic Model | Frame Color | Seat & Back Color | Armrest Color | Glide Option | Upholstery Color | Fire Code | |
|  | Four-Leg Armless Chair | Polypropylene | TLNAP | <input type="checkbox"/> | <input type="checkbox"/> | | | <input type="checkbox"/> | <input type="checkbox"/> | 22.0# |
| | <ul style="list-style-type: none"> • Flex back • No arm • Stacking • Glide is plastic and standard | Upholstered | TLNAU | <input type="checkbox"/> | <input type="checkbox"/> | | | <input type="checkbox"/> | <input type="checkbox"/> | 24.0# |
| TLP | | | | | | | | | | |
| TLU | | | | | | | | | | |
|  | Four-Leg Arm Chair | Polypropylene | TLFAP | <input type="checkbox"/> | <input type="checkbox"/> | <input type="checkbox"/> | | <input type="checkbox"/> | <input type="checkbox"/> | 23.0# |
| | <ul style="list-style-type: none"> • Flex back • Stacking • Glide is plastic and standard | Upholstered | TLFAU | <input type="checkbox"/> | <input type="checkbox"/> | <input type="checkbox"/> | <input type="checkbox"/> | <input type="checkbox"/> | <input type="checkbox"/> | 25.0# |
| TLP | | | | | | | | | | |
| TLU | | | | | | | | | | |

A **B** **C** **D** **E** **F** **G**

HOW TO ORDER

Indicate the following information on order form:

1. Quantity of each item.
2. Model number, including options. See "How To Build a Model Number".
3. Any special service required.

Note: • The indicates that a choice is required.

- The absence of the indicates that no choice is required.
- Alpha-numeric characters in place of

indicate that no other alternatives are available.

HOW TO BUILD A MODEL NUMBER

A Select basic model.

B Select frame color. Refer to the **Product Color Options** page in this price list.

The metal back support matches the frame color.

When Hammertone or chrome frames are specified, back support matches seat and back color.

The arm support and tablet arm support match the frame color.

C Select seat and back color. Refer to the **Product Color Options** page in this price list.

D Select armrest color.

E Select glide option.
P - Plastic glides
S - Stainless steel glides

F Select upholstery grade/color. Refer to ki.com/fabrics

G Select fire code.
FR - Compliance to TB 133
NFR - Compliance to TB 117-2013



| Delivered Pricing Upholstered | Delivered Pricing Fabric Grade 1 & C.O.M. | Delivered Pricing Fabric Grade 2 | Delivered Pricing Fabric Grade 3 | Delivered Pricing Vinyl Group 2V | Delivered Pricing Pallas Fabric Group P0 | Delivered Pricing Pallas Fabric Group P1 | Delivered Pricing Pallas Fabric Group P2 | Delivered Pricing Pallas Fabric Group P3 | Delivered Pricing Pallas Fabric Group P4 |
|-------------------------------|---|----------------------------------|----------------------------------|----------------------------------|--|--|--|--|--|
| \$ 306 | | | | | | | | | |
| N/A | 520 | 566 | 576 | 576 | 526 | 539 | 562 | 587 | 608 |
| \$ 466 | | | | | | | | | |
| N/A | 679 | 724 | 734 | 734 | 681 | 694 | 719 | 744 | 768 |

UPHOLSTERY INFORMATION

C.O.M. Upholstery

C.O.M. requirement for 10 chairs or less is 3/4 yard per chair of 54" wide nondirectional fabric. For orders of 11 or more chairs and for complete information on ordering C.O.M., see "Ordering C.O.M., C.O.V. and C.O.L." section.

OPTIONS

California TB133 Fire Safety Code

For California Technical Bulletin 133 compliant models, add the following upcharge:

Model=Polypropylene
Added Lead Time=1 week
Added list price=\$76

Model=Upholstered
Added Lead Time=1 week
Added list price=\$85

Note:

Torsion in 2V Vinyl with FR requires a customer waiver since addition of the FR fire barrier to the upholstery detracts from the aesthetics of the chair.

SPECIAL SERVICES

Special Carton Marking

With specially marked information N/C



Shipping

Ships **assembled, FOB Green Bay, WI 54302, freight prepaid.** Freight class 125.

Specifications and prices are subject to change without prior notice.

Stack/Nesting

Torsion®

| | MODEL | Features | MODEL NUMBER | | | | | | | | |
|---|--|---------------------------|--------------|--------------------------|--------------------------|--------------------------|--------------------------|--------------------------|--------------------------|--------------------------|--------------------------|
| | | | Basic Model | Frame Color | Seat & Back Color | Tablet Arm Color | Glide Option | Upholstery Color | Fire Code | | |
|  | Four-Leg Tablet Arm Chair • Flex back • Stacking • Glide is plastic and standard • Flip-up tablet | Polypropylene, Left Hand | TLTALP | <input type="checkbox"/> | <input type="checkbox"/> | <input type="checkbox"/> | <input type="checkbox"/> | <input type="checkbox"/> | <input type="checkbox"/> | | |
| | | Polypropylene, Right Hand | TLTARP | <input type="checkbox"/> | <input type="checkbox"/> | <input type="checkbox"/> | <input type="checkbox"/> | <input type="checkbox"/> | <input type="checkbox"/> | <input type="checkbox"/> | |
| | | Upholstered, Left Hand | TLTALU | <input type="checkbox"/> | <input type="checkbox"/> | <input type="checkbox"/> | <input type="checkbox"/> | <input type="checkbox"/> | <input type="checkbox"/> | <input type="checkbox"/> | <input type="checkbox"/> |
| | | Upholstered, Right Hand | TLTARU | <input type="checkbox"/> | <input type="checkbox"/> | <input type="checkbox"/> | <input type="checkbox"/> | <input type="checkbox"/> | <input type="checkbox"/> | <input type="checkbox"/> | <input type="checkbox"/> |
| | | | | | | | | | | | |
| TLP | | | | | | | | | | | |
| TLU | | | | | | | | | | | |
|  | Four-Leg G2-Tablet Arm Chair • Flex back • NONSTACKING • Glide is plastic and standard • Fold-down tablet | Polypropylene, Left Hand | TLG2ALP | <input type="checkbox"/> | <input type="checkbox"/> | <input type="checkbox"/> | <input type="checkbox"/> | <input type="checkbox"/> | <input type="checkbox"/> | <input type="checkbox"/> | |
| | | Polypropylene, Right Hand | TLG2ARP | <input type="checkbox"/> | <input type="checkbox"/> | <input type="checkbox"/> | <input type="checkbox"/> | <input type="checkbox"/> | <input type="checkbox"/> | <input type="checkbox"/> | <input type="checkbox"/> |
| | | Upholstered, Left Hand | TLG2ALU | <input type="checkbox"/> | <input type="checkbox"/> | <input type="checkbox"/> | <input type="checkbox"/> | <input type="checkbox"/> | <input type="checkbox"/> | <input type="checkbox"/> | <input type="checkbox"/> |
| | | Upholstered, Right Hand | TLG2ARU | <input type="checkbox"/> | <input type="checkbox"/> | <input type="checkbox"/> | <input type="checkbox"/> | <input type="checkbox"/> | <input type="checkbox"/> | <input type="checkbox"/> | <input type="checkbox"/> |
| | | | | | | | | | | | |
| TLP | | | | | | | | | | | |
| TLU | | | | | | | | | | | |

A **B** **C** **D** **E** **F** **G**

HOW TO ORDER

Indicate the following information on order form:

- Quantity of each item.
- Model number, including options. See "How To Build a Model Number".
- Any special service required.

Note: • The indicates that a choice is required.

- The absence of the indicates that no choice is required.
- Alpha-numeric characters in place of

indicate that no other alternatives are available.

HOW TO BUILD A MODEL NUMBER

A Select basic model.

B Select frame color.
 Refer to the **Product Color Options** page in this price list.
 The metal back support matches the frame color.
 When Hammertone or chrome frames are specified, back support matches seat and back color.
 The arm support and tablet arm support match the frame color.

C Select seat and back color.
 Refer to the **Product Color Options** page in this price list.

D Select tablet arm color.
 Refer to the **Product Color Options** page in this price list.

E Select glide option.

- P** - Plastic glides
- S** - Stainless steel glides

F Select upholstery grade/color.
 Refer to ki.com/fabrics

G Select fire code.

- FR** - Compliance to TB 133
- NFR** - No Fire Retardant
- NFR** - Compliance to TB 117-2013



| Approx. Packaged Weight | Delivered Pricing Upholstered | Delivered Pricing Fabric Grade 1 & C.O.M. | Delivered Pricing Fabric Grade 2 | Delivered Pricing Fabric Grade 3 | Delivered Pricing Vinyl Group 2V | Delivered Pricing Pallas Fabric Group P0 | Delivered Pricing Pallas Fabric Group P1 | Delivered Pricing Pallas Fabric Group P2 | Delivered Pricing Pallas Fabric Group P3 | Delivered Pricing Pallas Fabric Group P4 |
|-------------------------|-------------------------------|---|----------------------------------|----------------------------------|----------------------------------|--|--|--|--|--|
| 32.0# | \$ 519 | | | | | | | | | |
| 32.0# | 519 | | | | | | | | | |
| 34.0# | N/A | 733 | 776 | 785 | 785 | 737 | 749 | 772 | 797 | 820 |
| 34.0# | N/A | 733 | 776 | 785 | 785 | 737 | 749 | 772 | 797 | 820 |
| 32.0# | \$ 616 | | | | | | | | | |
| 32.0# | 616 | | | | | | | | | |
| 34.0# | N/A | 828 | 870 | 880 | 880 | 829 | 840 | 867 | 890 | 913 |
| 34.0# | N/A | 828 | 870 | 880 | 880 | 829 | 840 | 867 | 890 | 913 |

UPHOLSTERY INFORMATION

C.O.M. Upholstery

C.O.M. requirement for 10 chairs or less is 3/4 yard per chair of 54" wide nondirectional fabric. For orders of 11 or more chairs and for complete information on ordering C.O.M., see "Ordering C.O.M., C.O.V. and C.O.L." section.

OPTIONS

California TB133 Fire Safety Code

For California Technical Bulletin 133 compliant models, add the following upcharge:

Model=Polypropylene
Added Lead Time=1 week
Added list price=\$76

Model=Upholstered
Added Lead Time=1 week
Added list price=\$85

Note:

Torsion® in 2V Vinyl with FR requires a customer waiver since addition of the FR fire barrier to the upholstery detracts from the aesthetics of the chair.

SPECIAL SERVICES

Special Carton Marking

With specially marked information N/C



Shipping

Ships **assembled, FOB Green Bay, WI 54302, freight prepaid.** Freight class 125.

Specifications and prices are subject to change without prior notice.

Stack/Nesting

Torsion®

| | MODEL | Features | MODEL NUMBER | | | | | | | Approx. Packaged Weight |
|---|---|---------------|--------------|--------------------------|--------------------------|--------------------------|--------------|--------------------------|--------------------------|-------------------------|
| | | | Basic Model | Frame Color | Seat & Back Color | Armrest Color | Glide Option | Upholstery Color | Fire Code | |
|  | Full Sled Base Armless Chair | Polypropylene | TSNAP | <input type="checkbox"/> | <input type="checkbox"/> | | | <input type="checkbox"/> | <input type="checkbox"/> | 22.0# |
| | <ul style="list-style-type: none"> Flex back No arm Stacks Glide is an option | Upholstered | TSNAU | <input type="checkbox"/> | <input type="checkbox"/> | | | <input type="checkbox"/> | <input type="checkbox"/> | 24.0# |
| | | | | | | | | | | |
| TSP | | | | | | | | | | |
| TSU | | | | | | | | | | |
|  | Full Sled Base Arm Chair | Polypropylene | TSFAP | <input type="checkbox"/> | <input type="checkbox"/> | <input type="checkbox"/> | | <input type="checkbox"/> | <input type="checkbox"/> | 23.0# |
| | <ul style="list-style-type: none"> Flex back NONSTACKING Glide is an option | Upholstered | TSFAU | <input type="checkbox"/> | <input type="checkbox"/> | <input type="checkbox"/> | | <input type="checkbox"/> | <input type="checkbox"/> | 25.0# |
| | | | | | | | | | | |
| TSP | | | | | | | | | | |
| TSU | | | | | | | | | | |

A **B** **C** **D** **E** **F** **G**

HOW TO ORDER

Indicate the following information on order form:

- Quantity of each item.
- Model number, including options. See "How To Build a Model Number".
- Any special service required.

Note: • The indicates that a choice is required.

- The absence of the indicates that no choice is required.
- Alpha-numeric characters in place of

indicate that no other alternatives are available.

HOW TO BUILD A MODEL NUMBER

A Select basic model.

B Select frame color. Refer to the **Product Color Options** page in this price list.

The metal back support matches the frame color.

When Hammertone or chrome frames are specified, back support matches seat and back color.

The arm support and tablet arm support match the frame color.

C Select seat and back color. Refer to the **Product Color Options** page in this price list.

D Select armrest color. Refer to the **Product Color Options** page in this price list.

E Select glide option.

- NGL** - No glides
- GNM** - Non-marring glides
- GNS** - Non-skid glides; add \$31
- GBL** - Plastic glides
- GSS** - Stainless steel glide; add \$31

F Select upholstery grade/color. Refer to ki.com/fabrics

G Select fire code.

- NFR** - Compliance to TB 117-2013
- FR** - Compliance to TB 133
- NFR** - No Fire Retardant



| Delivered Pricing Upholstered | Delivered Pricing Fabric Grade 1 & C.O.M. | Delivered Pricing Fabric Grade 2 | Delivered Pricing Fabric Grade 3 | Delivered Pricing Vinyl Group 2V | Delivered Pricing Pallas Fabric Group P0 | Delivered Pricing Pallas Fabric Group P1 | Delivered Pricing Pallas Fabric Group P2 | Delivered Pricing Pallas Fabric Group P3 | Delivered Pricing Pallas Fabric Group P4 |
|-------------------------------|---|----------------------------------|----------------------------------|----------------------------------|--|--|--|--|--|
| \$ 306 | | | | | | | | | |
| N/A | 520 | 566 | 576 | 576 | 526 | 539 | 562 | 587 | 608 |
| \$ 466 | | | | | | | | | |
| N/A | 679 | 724 | 734 | 734 | 681 | 694 | 719 | 744 | 768 |

UPHOLSTERY INFORMATION

C.O.M. Upholstery

C.O.M. requirement for 10 chairs or less is 3/4 yard per chair of 54" wide nondirectional fabric. For orders of 11 or more chairs and for complete information on ordering C.O.M., see "Ordering C.O.M., C.O.V. and C.O.L." section.

OPTIONS

California TB133 Fire Safety Code

For California Technical Bulletin 133 compliant models, add the following upcharge:

Model=Polypropylene
Added Lead Time=1 week
Added list price=\$76

Model=Upholstered
Added Lead Time=1 week
Added list price=\$85

Note:

Torsion® in 2V Vinyl with FR requires a customer waiver since addition of the FR fire barrier to the upholstery detracts from the aesthetics of the chair.

SPECIAL SERVICES

Special Carton Marking

With specially marked information N/C



Shipping

Ships **assembled, FOB Green Bay, WI 54302, freight prepaid.** Freight class 125.

Specifications and prices are subject to change without prior notice.

Stack/Nesting

Torsion®

| | MODEL | Features | MODEL NUMBER | | | | | | | | |
|--|--|---------------------------|--------------|--------------------------|--------------------------|--------------------------|--------------------------|--------------------------|--------------------------|--------------------------|--------------------------|
| | | | Basic Model | Frame Color | Seat & Back Color | Tablet Arm Color | Glide Option | Upholstery Color | Fire Code | | |
|  <p>TSP TSU</p> | Full Sled Base Tablet Arm Chair • Flex back • NONSTACKING • Glide is an option • Flip-up tablet • Tablet arm is 19-1/2" long and 12-3/4" wide | Polypropylene, Left Hand | TSTALP | <input type="checkbox"/> | <input type="checkbox"/> | <input type="checkbox"/> | <input type="checkbox"/> | <input type="checkbox"/> | <input type="checkbox"/> | | |
| | | Polypropylene, Right Hand | TSTARP | <input type="checkbox"/> | <input type="checkbox"/> | <input type="checkbox"/> | <input type="checkbox"/> | <input type="checkbox"/> | <input type="checkbox"/> | <input type="checkbox"/> | |
| | | Upholstered, Left Hand | TSTALU | <input type="checkbox"/> | <input type="checkbox"/> | <input type="checkbox"/> | <input type="checkbox"/> | <input type="checkbox"/> | <input type="checkbox"/> | <input type="checkbox"/> | <input type="checkbox"/> |
| | | Upholstered, Right Hand | TSTARU | <input type="checkbox"/> | <input type="checkbox"/> | <input type="checkbox"/> | <input type="checkbox"/> | <input type="checkbox"/> | <input type="checkbox"/> | <input type="checkbox"/> | <input type="checkbox"/> |
| | | | | | | | | | | | |
|  <p>TSP TSU</p> | Full Sled Base G2-Tablet Arm Chair • Flex back • NONSTACKING • Glide is an option • Fold-down tablet • Tablet arm is 18" long and 13-3/4" wide | Polypropylene, Left Hand | TSG2ALP | <input type="checkbox"/> | <input type="checkbox"/> | <input type="checkbox"/> | <input type="checkbox"/> | <input type="checkbox"/> | <input type="checkbox"/> | | |
| | | Polypropylene, Right Hand | TSG2ARP | <input type="checkbox"/> | <input type="checkbox"/> | <input type="checkbox"/> | <input type="checkbox"/> | <input type="checkbox"/> | <input type="checkbox"/> | <input type="checkbox"/> | |
| | | Upholstered, Left Hand | TSG2ALU | <input type="checkbox"/> | <input type="checkbox"/> | <input type="checkbox"/> | <input type="checkbox"/> | <input type="checkbox"/> | <input type="checkbox"/> | <input type="checkbox"/> | <input type="checkbox"/> |
| | | Upholstered, Right Hand | TSG2ARU | <input type="checkbox"/> | <input type="checkbox"/> | <input type="checkbox"/> | <input type="checkbox"/> | <input type="checkbox"/> | <input type="checkbox"/> | <input type="checkbox"/> | <input type="checkbox"/> |
| | | | | | | | | | | | |

A **B** **C** **D** **E** **F** **G**

HOW TO ORDER

Indicate the following information on order form:

- Quantity of each item.
- Model number, including options. See "How To Build a Model Number".
- Any special service required.

Note: • The indicates that a choice is required.

- The absence of the indicates that no choice is required.
- Alpha-numeric characters in place of indicate that no other alternatives are available.

HOW TO BUILD A MODEL NUMBER

A Select basic model.

B Select frame color.
Refer to the **Product Color Options** page in this price list.

The metal back support, arm support, and tablet arm support matches the frame color.

When Hammertone or chrome frames are specified, back support matches seat and back color.

C Select seat and back color.

Refer to the **Product Color Options** page in this price list.

D Select tablet arm color.

Refer to the **Product Color Options** page in this price list.

E Select glide option.

- NGL** - No glides
- GNM** - Non-marring glides
- GNS** - Non-skid glides; add \$31
- GBL** - Plastic glides
- GSS** - Stainless steel glide; add \$31

F Select upholstery grade/color.

Refer to ki.com/fabrics

G Select fire code.

- FR** - Compliance to TB 133
- NFR** - No Fire Retardant
- NFR** - Compliance to TB 117-2013



| Approx. Packaged Weight | Delivered Pricing Upholstered | Delivered Pricing Fabric Grade 1 & C.O.M. | Delivered Pricing Fabric Grade 2 | Delivered Pricing Fabric Grade 3 | Delivered Pricing Vinyl Group 2V | Delivered Pricing Pallas Fabric Group P0 | Delivered Pricing Pallas Fabric Group P1 | Delivered Pricing Pallas Fabric Group P2 | Delivered Pricing Pallas Fabric Group P3 | Delivered Pricing Pallas Fabric Group P4 |
|-------------------------|-------------------------------|---|----------------------------------|----------------------------------|----------------------------------|--|--|--|--|--|
| 32.0# | \$ 519 | | | | | | | | | |
| 32.0# | 519 | | | | | | | | | |
| 34.0# | N/A | 733 | 776 | 785 | 785 | 737 | 749 | 772 | 797 | 820 |
| 34.0# | N/A | 733 | 776 | 785 | 785 | 737 | 749 | 772 | 797 | 820 |

| | | | | | | | | | | |
|-------|--------|-----|-----|-----|-----|-----|-----|-----|-----|-----|
| 32.0# | \$ 616 | | | | | | | | | |
| 32.0# | 616 | | | | | | | | | |
| 34.0# | N/A | 828 | 870 | 880 | 880 | 829 | 840 | 867 | 890 | 913 |
| 34.0# | N/A | 828 | 870 | 880 | 880 | 829 | 840 | 867 | 890 | 913 |

UPHOLSTERY INFORMATION

C.O.M. Upholstery

C.O.M. requirement for 10 chairs or less is 3/4 yard per chair of 54" wide nondirectional fabric. For orders of 11 or more chairs and for complete information on ordering C.O.M., see "Ordering C.O.M., C.O.V. and C.O.L." section.

OPTIONS

California TB133 Fire Safety Code

For California Technical Bulletin 133 compliant models, add the following upcharge:

Model=Polypropylene
 Added Lead Time=1 week
 Added list price=\$76

Model=Upholstered
 Added Lead Time=1 week
 Added list price=\$85

Note:

Torsion® in 2V Vinyl with FR requires a customer waiver since addition of the FR fire barrier to the upholstery detracts from the aesthetics of the chair.

SPECIAL SERVICES

Special Carton Marking

With specially marked information N/C

Shipping

Ships **assembled, FOB Green Bay, WI 54302, freight prepaid.** Freight class 125.

Specifications and prices are subject to change without prior notice.

Stack/Nesting

Torsion®

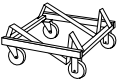
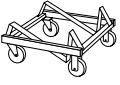
| | MODEL | MODEL NUMBER | |
|--|---|--------------|-------------------------|
| | | Basic Model | Approx. Packaged Weight |
|  HRDPT | Transport Dolly for Sled Base Chairs <ul style="list-style-type: none"> • For full sled base chairs (TS) • 5" casters: two fixed, two swivel • Black only | TVD.BL | 30.0# |
| | | | |
| | | | |
| | | | |
|  HRDPT | Transport Dolly for Four-Leg Chairs <ul style="list-style-type: none"> • For four-Leg chairs only (TL) • 5" casters: two fixed, two swivel • Black only | TLD.BL | 31.0# |
| | | | |
| | | | |
| | | | |

A

HOW TO ORDER

Indicate the following information on order form:

1. Quantity of each item.
2. Model number, including options. See "How To Build a Model Number".
3. Any special service required.

Note: • The indicates that a choice is required.

- The absence of the indicates that no choice is required.
- Alpha-numeric characters in place of indicate that no other alternatives are available.

HOW TO BUILD A MODEL NUMBER

A Select basic model.



Delivered
Pricing
\$ 456

\$ 456

SPECIAL SERVICES

Special Carton Marking

With specially marked information N/C

Shipping

Ships **assembled, FOB Green Bay, WI 54302, freight prepaid.** Freight class 125.

Specifications and prices are subject to change without prior notice.

Stack/Nesting

Torsion Air™ General Information



Four-Leg Armless Chair (TALNA)



Four-Leg Arm Chair (TALWA)



Four-Leg Standard Tablet Arm Chair (TALTAR)

| Features | | | |
|---------------------|-------------------|-------------------|---------|
| Back flex | • | • | • |
| Stackable | • | • | |
| General Dimensions | | | |
| Seat width | 17" | 17" | 17" |
| Seat depth | 18-1/2" | 18-1/2" | 18-1/2" |
| Seat height | 18" | 18" | 18" |
| Back width | 17" | 17" | 17" |
| Back height | 16" | 16" | 16" |
| Overall Dimensions | | | |
| Width | 21" | 23-1/2" | 23" |
| Depth | 23-3/4" | 23-3/4" | 29-3/4" |
| Height | 34" | 34" | 34" |
| Top of arm to floor | | 25-1/2" | 28" |
| Stacking on Dolly | | | |
| Quantity/height | 5 Chairs/55" High | 5 Chairs/55" High | |
| Floor space | 22-1/2" x 25-1/2" | 23-1/2" x 25-1/2" | |
| Stacking on Floor | | | |
| Quantity/height | 4 Chairs/45" High | 4 Chairs/45" High | |
| Floor space | 21" x 32" | 23-1/2" x 32" | |

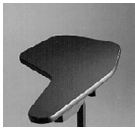

Standard Flip-Up Tablet Arm

SPECIFICATIONS

Seat and Backrest

Seat is a two-piece construction with a molded polypropylene liner with a molded compound curved polypropylene shroud with a textured finish. Seat is always upholstered. Foam (1-1/2") is applied to the molded polypropylene liner. Fabric is then upholstered over the foam. Backrest frame is molded glass-reinforced nylon. Mesh fabric is 100% polyester. Seat and backrest are field-replaceable.

Back/Arm Supports

Two welded steel backrest supports attach the backrest to the torsion mechanism. If so equipped, optional armrest structure is integral to the backrest support. Armcaps are polypropylene and are field-replaceable.

Full Sled Base Frame (TAS)

The sled base frame consists of two segments of 3/4" 16-gauge seam welded tubular steel and two steel seat supports.

Four Leg Frame (TAL)

The four leg frame consists of two U-shaped sections, one front and one rear, welded together with two support brackets to form the four leg chair. The sections are formed of 15/16" 15-gauge seam welded tubular steel.

Leg Finishes

Baked-on, electrostatically-applied powder-coating, or bright nickel-chrome plating.

Standard Tablet Arms

5/8" 11-ply plywood tablet with high-pressure laminate surface and lacquered edge. Tablet arm support matches frame color. Seating clearance is 13 1/2". Standard tablet measures 19 1/2" long and 12 3/4" wide.

Torsion Mechanism

The back flex is achieved by the torsion mechanism. It consists of two flat torsion springs captured at both ends by steel bushings that are welded to the backrest supports. The torsion mechanism creates gradually increasing resistance over the full 12° of back flex.

Stacking Vinyl Upholstered Chairs

It is recommended that chairs to be stacked be covered in material other than vinyl as an impression in the seat may result. KI does not warrant the effects of stacking on stock or C.O.M. vinyl upholstery.

Stacking Vinyl, Polyurethane, and Imitation Leather Upholstered Chairs

It is recommended that chairs to be stacked be covered in material other than vinyl, polyurethane, or imitation leather as an impression in the seat may result. KI does not warrant the effects of stacking on stock or C.O.M. vinyl, polyurethane, or imitation leather upholstery.

Transport Dolly

Tubular and plate steel welded together. 5" casters; two fixed, two swivel. Powder coated finish. Two distinct dollies are available; one for full Sled Base, and one for Four Leg.



Stack/Nesting

Torsion Air™ General Information



Sled Base Armless Chair (TASNA)



Sled Base Arm Chair (TASWA)



Sled Base Standard Tablet Arm Chair (TASTAR)

| Features | | | |
|---------------------------|-------------------|-------------------|---------|
| Back flex | • | • | • |
| Stackable | • | • | |
| General Dimensions | | | |
| Seat width | 17" | 17" | 17" |
| Seat depth | 18-1/2" | 18-1/2" | 18-1/2" |
| Seat height | 18" | 18" | 18" |
| Back width | 17" | 17" | 17" |
| Back height | 16" | 16" | 16" |
| Overall Dimensions | | | |
| Width | 21" | 23-1/2" | 23" |
| Depth | 23-3/4" | 23-3/4" | 29-3/4" |
| Height | 34" | 34" | 34" |
| Top of arm to floor | | 25-1/2" | 28" |
| Stacking on Dolly | | | |
| Quantity/height | 5 Chairs/55" High | 5 Chairs/55" High | |
| Floor space | 22-1/2" x 25-1/2" | 23-1/2" x 25-1/2" | |
| Stacking on Floor | | | |
| Quantity/height | 4 Chairs/45" High | 4 Chairs/45" High | |
| Floor space | 21" x 32" | 23-1/2" x 32" | |

INFORMATION

C.O.M Testing and Production Requirements

Not all materials are suitable for upholstering this product. A 3/4 yd. x 54" sample must be submitted and approved prior to acceptance of an order. If the fabric is directional in pattern or weave, the direction must be indicated on the submitted sample, and additional yardage may be requested.

Test samples must be sent to:

KI
Attn: C.O.M. Specialist
1687 Westminster Drive - Gate 3
Green Bay, WI 54302

Fabric Disclaimer

Fabric will be applied as swatched by the fabric manufacturer. Fabric that is required to be applied differently than is swatched will need a Special Cost Request written specifying the direction the fabric is to be applied. The posted standard lead time will apply to the Special Cost Request.

INFORMATION

Warranty

Refer to KI Terms & Conditions document or visit ki.com

Stack/Nesting

Torsion Air® Color Options

Frame Color

| | |
|---------------------------|----|
| Antique Vein | AV |
| Black | BL |
| Blue Grey | GR |
| Bronze Metallic | ZM |
| Cayenne | CY |
| Champagne Metallic | CM |
| Chocolate | CT |
| Chrome | CH |
| Cool Grey | CG |
| Cottonwood | CO |
| Espresso Metallic | EX |
| Flannel | FN |
| Light Tone | LG |
| Mardi Gras | MG |
| Misty Brown | MY |
| Nemo | NE |
| Nickel Vein | NK |
| Nordic | ND |
| Purple Haze | PH |
| Rubber Ducky | RK |
| Sand | SA |
| Splash | SH |
| Starlight Silver Metallic | SX |
| Surf's Up | SP |
| Ultra Blue | UB |
| Warm Grey | WG |
| Wet Sand | WS |
| Zesty Lime | ZL |

Back Mesh

| | |
|-------|------|
| Black | BLMH |
| Grey | GRMH |

Tablet Arm Color - Laminate

Flip and G-Tablet

| | |
|--------------------|-----|
| Biltmore Cherry | LBT |
| Black | LBK |
| Brighton Walnut | LBW |
| Canyon Zephyr | LCA |
| Castle Oak | LCO |
| Casual Linen | LCU |
| Cherry Storm | LCX |
| Classic Linen | LCI |
| Cloud Zephyr | LCL |
| Cocobala | LCC |
| Coffee Bean | LCB |
| Crisp Linen | LRI |
| Desert Zephyr | LDZ |
| Dove Grey | LDG |
| Fired Steel | LIL |
| Flax Linen | LXF |
| Florence Walnut | LFC |
| Forged Steel | LOL |
| Frosty White | LFW |
| Graphite Nebula | LGN |
| Grey | LGE |
| High Rise | LHE |
| Hollyberry | LHY |
| Irish Linen | LIH |
| Island | LID |
| Italian Silver Ash | LIT |
| Kensington Maple | LKM |
| Lapis Blue | LLB |
| Markerboard White | LMK |
| Misted Zephyr | LMR |
| Monticello Maple | LMT |
| Nickel Evolv | LNV |
| North Sea | LNA |
| Ocean | LON |
| Orange Grove | LOE |
| Pearl Bisque | LPB |
| Pearl Silver | LPS |
| Pressed Linen | LPR |
| River Cherry | LRV |
| Rugged Linen | LRG |
| Satin Stainless | LSS |
| Shadow Zephyr | LSR |
| Silicon evolv | LSV |
| Sterling Ash | LAZ |
| Tailored Linen | LTL |
| Titanium evolv | LTV |
| White Nebula | LWL |
| White Sand | LWN |
| Windsor Mahogany | LWY |

Tablet Arm Color - Piretti Tablet

| | |
|-------|-----|
| Black | LBK |
|-------|-----|

Finish Cards

View color swatches for items listed within this document.

Paints

Plastics/Poly

Wood/Veneer

Laminates

Molded Edges

Edge Styles



Hard Plastics

Glass



Stack/Nesting

Torsion Air™

| MODEL | Features | MODEL NUMBER | | | | | | |
|---|---|------------------|--|--|--|--|--|--|
| | | Basic Model | Frame Color | Tablet Arm Color | Glide Option | Upholstery Color | Fire Code | Mesh Color |
|  <p>Four-Leg Armless Chair</p> <ul style="list-style-type: none"> • Back flex • Mesh back • Stacking | | TALNA | <input type="checkbox"/> | | <input type="checkbox"/> | <input type="checkbox"/> <input type="checkbox"/> <input type="checkbox"/> <input type="checkbox"/> | <input type="checkbox"/> <input type="checkbox"/> | <input type="checkbox"/> <input type="checkbox"/> <input type="checkbox"/> <input type="checkbox"/> |
| TALC | | | | | | | | |
|  <p>Four-Leg Arm Chair</p> <ul style="list-style-type: none"> • Back flex • Mesh back • Stacking | | TALWA | | | <input type="checkbox"/> | <input type="checkbox"/> <input type="checkbox"/> <input type="checkbox"/> <input type="checkbox"/> <input type="checkbox"/> | <input type="checkbox"/> <input type="checkbox"/> | <input type="checkbox"/> <input type="checkbox"/> <input type="checkbox"/> <input type="checkbox"/> |
| TALC | | | | | | | | |
|  <p>Four-Leg Tablet Arm Chair</p> <ul style="list-style-type: none"> • Back flex • Mesh back • Stacking | Standard Tablet, Left Hand Standard Tablet, Right Hand | TALTAL TALTAR | <input type="checkbox"/> <input type="checkbox"/> | <input type="checkbox"/> <input type="checkbox"/> <input type="checkbox"/> <input type="checkbox"/> | <input type="checkbox"/> <input type="checkbox"/> | <input type="checkbox"/> <input type="checkbox"/> <input type="checkbox"/> <input type="checkbox"/> <input type="checkbox"/> <input type="checkbox"/> <input type="checkbox"/> <input type="checkbox"/> <input type="checkbox"/> <input type="checkbox"/> | <input type="checkbox"/> <input type="checkbox"/> | <input type="checkbox"/> <input type="checkbox"/> <input type="checkbox"/> <input type="checkbox"/> <input type="checkbox"/> <input type="checkbox"/> <input type="checkbox"/> <input type="checkbox"/> |
| TALC | | | | | | | | |

A **B** **C** **D** **E** **F** **G**

HOW TO ORDER

Indicate the following information on order form:

1. Quantity of each item.
2. Model number, including options. See "How To Build a Model Number".
3. Any special service required.

Note:

- The indicates that a choice is required.
- The absence of the indicates that no choice is required.
- Alpha-numeric characters in place of indicate that no other alternatives are available.

HOW TO BUILD A MODEL NUMBER

- A** Select basic model.
- B** Select frame color.
Refer to the **Product Color Options** page in this price list.
- C** Select tablet arm color.
Refer to the **Product Color Options** page in this price list.
- D** Select glide option.

| | |
|----------|--------------------------|
| P | - Plastic glides |
| S | - Stainless steel glides |
- E** Select upholstery grade/color.
Refer to ki.com/fabrics
- F** Select fire code.

| | |
|------------|-----------------------------|
| NFR | - Compliance to TB 117-2013 |
| FR | - Compliance to TB 133 |

G Select back mesh color.

- | | |
|-------------|---------|
| BLMH | - Black |
| GRMH | - Grey |
- Refer to ki.com/fabrics



| Approx. Packaged Weight | Delivered Pricing Fabric Grade 1 & C.O.M. | Delivered Pricing Fabric Grade 2 | Delivered Pricing Fabric Grade 3 | Delivered Pricing Vinyl Group 2V | Delivered Pricing Pallas Fabric Group P0 | Delivered Pricing Pallas Fabric Group P1 | Delivered Pricing Pallas Fabric Group P2 | Delivered Pricing Pallas Fabric Group P3 | Delivered Pricing Pallas Fabric Group P4 |
|-------------------------|---|----------------------------------|----------------------------------|----------------------------------|--|--|--|--|--|
| 18.0# | \$ 551 | \$ 566 | \$ 582 | \$ 582 | \$ 591 | \$ 631 | \$ 649 | \$ 671 | \$ 697 |
| 20.0# | \$ 581 | \$ 595 | \$ 615 | \$ 615 | \$ 620 | \$ 659 | \$ 679 | \$ 700 | \$ 726 |
| 28.0# | \$ 764 | \$ 777 | \$ 798 | \$ 798 | \$ 803 | \$ 842 | \$ 862 | \$ 881 | \$ 910 |
| 28.0# | 764 | 777 | 798 | 798 | 803 | 842 | 862 | 881 | 910 |

UPHOLSTERY INFORMATION
C.O.M. Upholstery

C.O.M. requirement for 10 chairs or less is 3/4 yard per chair of 54" wide nondirectional fabric. For orders of 11 or more chairs and for complete information on ordering C.O.M., see "Ordering C.O.M., C.O.V. and C.O.L." section.

OPTIONS
California TB133 Fire Safety Code

For California Technical Bulletin 133 compliant models, add the following upcharge:

Added Lead Time=1 week
 Added list price=\$51

SPECIAL SERVICES
Special Carton Marking

With specially marked information N/C



Shipping

Ships **assembled, FOB Green Bay, WI 54302, freight prepaid.** Freight class 125.

Specifications and prices are subject to change without prior notice.

Stack/Nesting

Torsion Air™

| MODEL | Features | MODEL NUMBER | | | | | | |
|---|---|------------------|--|--|--|--|--|--|
| | | Basic Model | Frame Color | Tablet Arm Color | Upholstery Color | Fire Code | Mesh Color | Glide Option |
|  <p>Sled Base Armless Chair</p> <ul style="list-style-type: none"> • Back flex • Mesh back • Stacking | | TASNA | <input type="checkbox"/> | | <input type="checkbox"/> <input type="checkbox"/> <input type="checkbox"/> <input type="checkbox"/> <input type="checkbox"/> | <input type="checkbox"/> | <input type="checkbox"/> <input type="checkbox"/> <input type="checkbox"/> | <input type="checkbox"/> <input type="checkbox"/> |
| TASC | | | | | | | | |
|  <p>Sled Base Arm Chair</p> <ul style="list-style-type: none"> • Back flex • Mesh back • Stacking | | TASWA | <input type="checkbox"/> | | <input type="checkbox"/> <input type="checkbox"/> <input type="checkbox"/> <input type="checkbox"/> <input type="checkbox"/> | <input type="checkbox"/> | <input type="checkbox"/> <input type="checkbox"/> <input type="checkbox"/> | <input type="checkbox"/> <input type="checkbox"/> |
| TASC | | | | | | | | |
|  <p>Sled Base Tablet Arm Chair</p> <ul style="list-style-type: none"> • Back flex • Mesh back • Nonstacking | Standard Tablet, Left Hand Standard Tablet, Right Hand | TASTAL TASTAR | <input type="checkbox"/> <input type="checkbox"/> | <input type="checkbox"/> <input type="checkbox"/> <input type="checkbox"/> <input type="checkbox"/> | <input type="checkbox"/> <input type="checkbox"/> <input type="checkbox"/> <input type="checkbox"/> | <input type="checkbox"/> <input type="checkbox"/> | <input type="checkbox"/> <input type="checkbox"/> <input type="checkbox"/> <input type="checkbox"/> <input type="checkbox"/> <input type="checkbox"/> | <input type="checkbox"/> <input type="checkbox"/> <input type="checkbox"/> <input type="checkbox"/> |
| TASC | | | | | | | | |

A **B** **C** **D** **E** **F** **G**

HOW TO ORDER

Indicate the following information on order form:

1. Quantity of each item.
2. Model number, including options. See "How To Build a Model Number".
3. Any special service required.

Note: • The indicates that a choice is required.

- The absence of the indicates that no choice is required.
- Alpha-numeric characters in place of indicate that no other alternatives are available.

HOW TO BUILD A MODEL NUMBER

- A** Select basic model.
- B** Select frame color.
Refer to the **Product Color Options** page in this price list.
- C** Select tablet arm color.
Refer to the **Product Color Options** page in this price list.
- D** Select upholstery grade/color.
Refer to ki.com/fabrics
- E** Select fire code.
NFR - Compliance to TB 117-2013
FR - Compliance to TB 133
- F** Select back mesh color.
BLMH - Black
GRMH - Grey
Refer to ki.com/fabrics

G Select glide option.

- N** - No glides
- GNM** - Non-marring glides
- GNS** - Non-skid glides
- GBL** - Plastic glides
- GSS** - Stainless steel glide



| Approx. Packaged Weight | Delivered Pricing Fabric Grade 1 & C.O.M. | Delivered Pricing Fabric Grade 2 | Delivered Pricing Fabric Grade 3 | Delivered Pricing Vinyl Group 2V | Delivered Pricing Pallas Fabric Group P0 | Delivered Pricing Pallas Fabric Group P1 | Delivered Pricing Pallas Fabric Group P2 | Delivered Pricing Pallas Fabric Group P3 | Delivered Pricing Pallas Fabric Group P4 |
|-------------------------|---|----------------------------------|----------------------------------|----------------------------------|--|--|--|--|--|
| 18.0# | \$ 551 | \$ 566 | \$ 582 | \$ 582 | \$ 591 | \$ 631 | \$ 649 | \$ 671 | \$ 697 |
| 20.0# | \$ 581 | \$ 595 | \$ 615 | \$ 615 | \$ 620 | \$ 659 | \$ 679 | \$ 700 | \$ 726 |
| 28.0# | \$ 764 | \$ 777 | \$ 798 | \$ 798 | \$ 803 | \$ 842 | \$ 862 | \$ 881 | \$ 910 |
| 28.0# | 764 | 777 | 798 | 798 | 803 | 842 | 862 | 881 | 910 |

UPHOLSTERY INFORMATION
C.O.M. Upholstery

C.O.M. requirement for 10 chairs or less is 3/4 yard per chair of 54" wide nondirectional fabric. For orders of 11 or more chairs and for complete information on ordering C.O.M., see "Ordering C.O.M., C.O.V. and C.O.L." section.

OPTIONS
California TB133 Fire Safety Code

For California Technical Bulletin 133 compliant models, add the following upcharge:

Added Lead Time=1 week
 Added list price=\$51

SPECIAL SERVICES
Special Carton Marking

With specially marked information N/C



Shipping

Ships **assembled, FOB Green Bay, WI 54302, freight prepaid.** Freight class 125.

Specifications and prices are subject to change without prior notice.

Stack/Nesting

Torsion Air™

| | MODEL | MODEL NUMBER | |
|--|---|--------------|-------------------------|
| | | Basic Model | Approx. Packaged Weight |
|  HRDPT | Transport Dolly for Sled Base Chairs • For full sled base chairs • 5" casters: two fixed, two swivel • Black only | TVD.BL | 30.0# |
| | | | |
| | | | |
| | | | |
|  HRDPT | Transport Dolly for Four-Leg Chairs • For four-Leg chairs only • 5" casters: two fixed, two swivel • Black only | TLD.BL | 31.0# |
| | | | |
| | | | |
| | | | |

A

HOW TO ORDER

Indicate the following information on order form:

1. Quantity of each item.
2. Model number, including options. See "How To Build a Model Number".
3. Any special service required.

Note: • The indicates that a choice is required.

- The absence of the indicates that no choice is required.
- Alpha-numeric characters in place of indicate that no other alternatives are available.

HOW TO BUILD A MODEL NUMBER

- A** Select basic model.



Delivered
Pricing

\$ 456

\$ 456

UPHOLSTERY INFORMATION

C.O.M. Upholstery

C.O.M. requirement for 10 chairs or less is 3/4 yard per chair of 54" wide nondirectional fabric. For orders of 11 or more chairs and for complete information on ordering C.O.M., see "Ordering C.O.M., C.O.V. and C.O.L." section.

SPECIAL SERVICES

Special Carton Marking

With specially marked information N/C

Shipping

Ships **assembled, FOB Green Bay, WI 54302, freight prepaid.** Freight class 125.

Specifications and prices are subject to change without prior notice.

Stack/Nesting

Torsion Air™ Nesting General Information



**Armless Chair
(TANNA)**



**Arm Chair
(TANWA)**



**Piretti Tablet
Arm Chair
(TANTARPT)**



**Flip-up Tablet
Arm Chair
(TANTARFD)**

| Features | | | | |
|--------------------------------|---------|---------|---------|---------|
| Back flex | • | • | • | • |
| Flip-up seat | • | • | • | • |
| Nesting | • | • | • | • |
| Casters | • | • | • | • |
| General Dimensions | | | | |
| Seat width | 17" | 17" | 17" | 17" |
| Seat depth | 18-1/2" | 18-1/2" | 18-1/2" | 18-1/2" |
| Seat height | 18" | 18" | 18" | 18" |
| Back width | 17" | 17" | 17" | 17" |
| Back height | 16" | 16" | 16" | 16" |
| Overall Dimensions | | | | |
| Width | 23-7/8" | 23-7/8" | 25" | 27" |
| Depth | 24-1/4" | 24-1/4" | 30-1/4" | 31" |
| Height | 33-1/2" | 33-1/2" | 33-1/2" | 33-1/2" |
| Top of arm to floor | | 24-7/8" | 28-1/2" | 28" |
| Depth of nesting (two chairs) | 28" | 28" | 34" | 35" |
| Depth of each additional chair | 7-1/2" | 7-1/2" | 7-1/2" | 7-1/2" |

SPECIFICATIONS

Seat and Backrest

Seat is two-piece construction of molded plywood upholstery board with a molded compound curved polypropylene shroud with a textured finish. Seat is always upholstered. Foam (1-3/4") is applied to the molded plywood upholstery board. Fabric is then upholstered over the foam. Backrest is available in either a poly or upholstered version. Backrest frame is molded glass-reinforced nylon. Mesh fabric is 100% polyester. Backrest has an integral "handle."

Seat flips up to allow chairs to nest for storage and transport.

Seat and back are field replaceable.

Backrest Supports

Two welded steel backrest supports attach the backrest to the torsion mechanism.

Torsion Mechanism

The back flex is achieved by the torsion mechanism. It consists of two flat torsion springs captured at both ends by steel bushings that are welded to the backrest supports. The torsion mechanism creates gradually increasing resistance over the full 12° of back flex.

Flip-Up Tablet

Available on RH or LH side. The tablet arm support structure is 1-inch diameter, 13-gauge tubing, welded to the main chair frame. A formed steel hinge is welded to the top of the support structure and secured with screws to the underside of the writing surface. Writing surface is nominally 9-1/2" x 20-3/4" x 12-1/2" plywood core of 5/8" thick, 11-ply hardwood, surfaced with 0.030" high-pressure laminate top and plain backer undersurface. Edges are lacquered and sealed. When so equipped, and with the tablet flipped up, chairs will nest with other Torsion Air chairs with tablets, or without.

Arms

Armrests are made of polypropylene. Armrests rotate with the back. Armrests are field replaceable.

Frame

The frame is made up of four legs welded to a steel mechanism tube. The legs are 1" diameter, 13-gauge high-strength low alloy steel tubing.

Leg Finishes

Baked on electrostatically applied 45 sheen epoxy powder coating or bright nickel chrome plating.

Casters/Glides

Double wheels (60mm) of high-impact thermoplastic. High-impact plastic frame. Carpet and hard floor casters are always black. Bell glide (2" high) made of high-impact plastic also available, black only.

Piretti Tablet

Available on RH or LH side. The tablet support is 1-3/16" OD x 14-gauge round steel tubing. The support is welded to the chair frame. The tablet mechanism consists of two die cast aluminum housings and a stamped steel hinge assembly. The main housing is mounted inside the steel support tube and secured with a thread-forming screw. The mechanism has two through-bolted pivot axes with bushing that allow stowing. The mechanism permits 12 degrees of horizontal rotation for ingress/egress without stowing the tablet. With the tablet stowed, the chair will nest with other Torsion Air chairs with or without tablets. The tablet is made from blow-molded high-density polyethylene and is only available in black. The tablet is connected to the mechanism and supported by a 12-gauge steel plate. The tablet has an effective working surface 12" deep by 16" across (overall dimensions are 12" deep by 22" across).



INFORMATION

C.O.M Testing and Production Requirements

Not all materials are suitable for upholstering this product. A 3/4 yd. x 54" sample must be submitted and approved prior to acceptance of an order. If the fabric is directional in pattern or weave, the direction must be indicated on the submitted sample, and additional yardage may be requested.

Test samples must be sent to:

KI
Attn: C.O.M. Specialist
1687 Westminster Drive - Gate 3
Green Bay, WI 54302

Fabric Disclaimer

Fabric will be applied as swatched by the fabric manufacturer. Fabric that is required to be applied differently than is swatched will need a Special Cost Request written specifying the direction the fabric is to be applied. The posted standard lead time will apply to the Special Cost Request.



INFORMATION

Warranty

Refer to KI Terms & Conditions document or visit ki.com

Stack/Nesting

Torsion Air™ Nesting Chairs

| MODEL | Features | MODEL NUMBER | | | | | | |
|--|-------------------------|--------------|--------------------------|---|--------------------------|---|---|--|
| | | Basic Model | Frame Color | Tablet Arm Color | Base | Upholstery Color | Fire Code | Mesh Color |
|  Armless Chair • Back flex • Mesh back TANC | | TANNA | <input type="checkbox"/> | | <input type="checkbox"/> | <input type="checkbox"/> <input type="checkbox"/> <input type="checkbox"/> <input type="checkbox"/> | <input type="checkbox"/> <input type="checkbox"/> | <input type="checkbox"/> <input type="checkbox"/> <input type="checkbox"/> |
| | | | | | | | | |
| | | | | | | | | |
| | | | | | | | | |
|  Armchair • Back flex • Mesh back TANC | | TANWA | <input type="checkbox"/> | | <input type="checkbox"/> | <input type="checkbox"/> <input type="checkbox"/> <input type="checkbox"/> <input type="checkbox"/> | <input type="checkbox"/> <input type="checkbox"/> | <input type="checkbox"/> <input type="checkbox"/> <input type="checkbox"/> |
| | | | | | | | | |
| | | | | | | | | |
| | | | | | | | | |
|  Flip-up Tablet Arm Chair • Back flex • Mesh back TANC | Flip Tablet, Left Hand | TANTALFT | <input type="checkbox"/> | <input type="checkbox"/> <input type="checkbox"/> | <input type="checkbox"/> | <input type="checkbox"/> <input type="checkbox"/> <input type="checkbox"/> <input type="checkbox"/> | <input type="checkbox"/> <input type="checkbox"/> | <input type="checkbox"/> <input type="checkbox"/> <input type="checkbox"/> |
| | Flip Tablet, Right Hand | TANTARFT | <input type="checkbox"/> | <input type="checkbox"/> <input type="checkbox"/> | <input type="checkbox"/> | <input type="checkbox"/> <input type="checkbox"/> <input type="checkbox"/> <input type="checkbox"/> | <input type="checkbox"/> <input type="checkbox"/> | <input type="checkbox"/> <input type="checkbox"/> <input type="checkbox"/> |
| | | | | | | | | |
| | | | | | | | | |

A **B** **C** **D** **E** **F** **G**

HOW TO ORDER

Indicate the following information on order form:

- Quantity of each item.
- Model number, including options. See "How To Build a Model Number".
- Any special service required.

Note: • The indicates that a choice is required.

- The absence of the indicates that no choice is required.
- Alpha-numeric characters in place of indicate that no other alternatives are available.

HOW TO BUILD A MODEL NUMBER

- A** Select basic model.
- B** Select frame color.
Refer to the **Product Color Options** page in this price list.
- C** Select tablet arm color.
Refer to the **Product Color Options** page in this price list.
- D** Select base option.

| | |
|----------|-----------------------------------|
| G | - Bell glides (black only) |
| C | - Carpet casters (black only) |
| S | - Hard floor casters (black only) |
- E** Select upholstery grade/color.
Refer to ki.com/fabrics
- F** Select fire code.

| | |
|------------|-----------------------------|
| NFR | - Compliance to TB 117-2013 |
| FR | - Compliance to TB 133 |

G Select back mesh color.

- | | |
|-------------|---------|
| BLMH | - Black |
| GRMH | - Grey |
- Refer to ki.com/fabrics



| Approx. Packaged Weight | Delivered Pricing Fabric Grade 1 & C.O.M. | Delivered Pricing Fabric Grade 2 | Delivered Pricing Fabric Grade 3 | Delivered Pricing Vinyl Group 2V | Delivered Pricing Pallas Fabric Group P0 | Delivered Pricing Pallas Fabric Group P1 | Delivered Pricing Pallas Fabric Group P2 | Delivered Pricing Pallas Fabric Group P3 | Delivered Pricing Pallas Fabric Group P4 |
|-------------------------|---|----------------------------------|----------------------------------|----------------------------------|--|--|--|--|--|
| 24.0# | \$ 745 | \$ 759 | \$ 774 | \$ 774 | \$ 783 | \$ 824 | \$ 840 | \$ 862 | \$ 889 |
| 25.0# | \$ 773 | \$ 794 | \$ 806 | \$ 806 | \$ 812 | \$ 853 | \$ 872 | \$ 891 | \$ 920 |
| 29.0# | \$ 956 | \$ 971 | \$ 989 | \$ 989 | \$ 995 | \$ 1036 | \$ 1055 | \$ 1074 | \$ 1101 |
| 29.0# | 956 | 971 | 989 | 989 | 995 | 1036 | 1055 | 1074 | 1101 |

UPHOLSTERY INFORMATION
C.O.M. Upholstery

C.O.M. requirement for 10 chairs or less is 3/4 yard per chair of 54" wide nondirectional fabric. For orders of 11 or more chairs and for complete information on ordering C.O.M., see "Ordering C.O.M., C.O.V. and C.O.L." section.

OPTIONS
California TB133 Fire Safety Code

For California Technical Bulletin 133 compliant models, add the following upcharge:

Added Lead Time=1 week
 Added list price=\$51

SPECIAL SERVICES
Special Carton Marking

With specially marked information N/C

Shipping

Ships **assembled, FOB Green Bay, WI 54302, freight prepaid.** Freight class 125.

Specifications and prices are subject to change without prior notice.

Stack/Nesting

Torsion Air™ Nesting Chairs

| MODEL | Features | MODEL NUMBER | | | | | |
|---|----------------------------|--------------|---|--------------------------|---|---|---|
| | | Basic Model | Frame Color | Base | Upholstery Color | Fire Code | Mesh Color |
|  <p>Piretti Tablet Arm Chair</p> <ul style="list-style-type: none"> • Back flex • Mesh back | Piretti Tablet, Left Hand | TANTALPT | <input type="checkbox"/> <input type="checkbox"/> | <input type="checkbox"/> | <input type="checkbox"/> <input type="checkbox"/> <input type="checkbox"/> <input type="checkbox"/> <input type="checkbox"/> <input type="checkbox"/> | <input type="checkbox"/> <input type="checkbox"/> | <input type="checkbox"/> <input type="checkbox"/> <input type="checkbox"/> <input type="checkbox"/> |
| | Piretti Tablet, Right Hand | TANTARPT | <input type="checkbox"/> <input type="checkbox"/> | <input type="checkbox"/> | <input type="checkbox"/> <input type="checkbox"/> <input type="checkbox"/> <input type="checkbox"/> <input type="checkbox"/> <input type="checkbox"/> | <input type="checkbox"/> <input type="checkbox"/> | <input type="checkbox"/> <input type="checkbox"/> <input type="checkbox"/> <input type="checkbox"/> |
| | | | | | | | |
| | | | | | | | |
| | | | | | | | |
| | | | | | | | |

TANC

A **B** **C** **D** **E** **F**

HOW TO ORDER

Indicate the following information on order form:

1. Quantity of each item.
2. Model number, including options. See "How To Build a Model Number".
3. Any special service required.

Note: • The indicates that a choice is required.

- The absence of the indicates that no choice is required.
- Alpha-numeric characters in place of indicate that no other alternatives are available.

HOW TO BUILD A MODEL NUMBER

- A** Select basic model.
- B** Select frame color.
Refer to the **Product Color Options** page in this price list.
- C** Select base option.

| | |
|----------|-----------------------------------|
| G | - Bell glides (black only) |
| C | - Carpet casters (black only) |
| S | - Hard floor casters (black only) |
- D** Select upholstery grade/color.
Refer to ki.com/fabrics
- E** Select fire code.

| | |
|------------|-----------------------------|
| NFR | - Compliance to TB 117-2013 |
| FR | - Compliance to TB 133 |
- F** Select back mesh color.

| | |
|-------------|---------|
| BLMH | - Black |
| GRMH | - Grey |

 Refer to ki.com/fabrics



| Approx. Packaged Weight | Delivered Pricing Fabric Grade 1 & C.O.M. | Delivered Pricing Fabric Grade 2 | Delivered Pricing Fabric Grade 3 | Delivered Pricing Vinyl Group 2V | Delivered Pricing Pallas Fabric Group P0 | Delivered Pricing Pallas Fabric Group P1 | Delivered Pricing Pallas Fabric Group P2 | Delivered Pricing Pallas Fabric Group P3 | Delivered Pricing Pallas Fabric Group P4 |
|-------------------------|---|----------------------------------|----------------------------------|----------------------------------|--|--|--|--|--|
| 34.0# | \$ 1072 | \$ 1088 | \$ 1104 | \$ 1104 | \$ 1112 | \$ 1151 | \$ 1171 | \$ 1190 | \$ 1219 |
| 34.0# | 1072 | 1088 | 1104 | 1104 | 1112 | 1151 | 1171 | 1190 | 1219 |

UPHOLSTERY INFORMATION
C.O.M. Upholstery

C.O.M. requirement for 10 chairs or less is 3/4 yard per chair of 54" wide nondirectional fabric. For orders of 11 or more chairs and for complete information on ordering C.O.M., see "Ordering C.O.M., C.O.V. and C.O.L." section.

SPECIAL SERVICES
Special Carton Marking

With specially marked information N/C

Shipping

Ships **assembled, FOB Green Bay, WI 54302, freight prepaid.** Freight class 125.

Specifications and prices are subject to change without prior notice.

Stack/Nesting

Versa® Basic General Information



**Arm Chair
(VBWAL)**



**Armless Chair
(VBNAL)**



**Transport Dolly
(VBD.BL)**

| Features | | | |
|---------------------|--------------------|--------------------|-------------------------|
| Stackable | • | • | |
| Plastic back shroud | • | • | |
| Steel tube arms | • | | |
| General Dimensions | | | |
| Seat width | 17-1/2" | 17-1/2" | |
| Seat depth | 17-1/2" | 17-1/2" | |
| Seat height | 17-1/2" | 17-1/2" | |
| Overall Dimensions | | | |
| Width | 21-5/8" | 19-3/8" | 22-3/8" |
| Depth | 21-1/4" | 21-1/4" | 24-7/8" No Arm/ 36" Arm |
| Height | 31" | 31" | |
| Arms to floor | 25-3/8" | | |
| Stacking on Dolly | | | |
| Quantity/height | 10 Chairs/52" High | 10 Chairs/52" High | |
| Stacking on Floor | | | |
| Quantity/height | 4 Chairs/40" High | 4 Chairs/40" High | |



Kick Back Leg

SPECIFICATIONS

Frame

Legs of 1" o.d. x 13-gauge tubular steel. "Kick back" rear legs on four-leg model increases structural integrity and adds to stability. Side members of 7/8" o.d. x 13-gauge tubular steel. All other joints are robotically welded.

Frame Finishes

Baked-on, electrostatically-applied epoxy powder coating, or bright nickel-chrome plated.

Basic Tube End Caps

Molded plastic. The end cap will match the frame color.

Upholstered Seat

Inner seat is 3/8" polypropylene. Fastens to frame with four screws through T-nuts embedded in seat. 1-1/8" thick polyfoam cushion glued to seatboard.

Upholstered Backrest

Two-piece construction. Inner back is 9-ply hard maple with 3/4" thick polyurethane foam. Outer back is vacuum-formed polystyrene attached with eight wood screws.

Stacking Vinyl, Polyurethane, and Imitation Leather Upholstered Chairs

It is recommended that chairs to be stacked be covered in material other than vinyl, polyurethane, or imitation leather as an impression in the seat may result. KI does not warrant the effects of stacking on stock or C.O.M. vinyl, polyurethane, or imitation leather upholstery.

Transport Dolly

Tubular steel frame, black powder-coated finish. Four 5" swivel wheels.



INFORMATION

C.O.M. Testing and Production Requirements

Not all materials are suitable for upholstering this product. A 1-1/2 yd. x 54" sample must be submitted and approved prior to acceptance of an order. If the fabric is directional in pattern or weave, the direction must be indicated on the submitted sample, and additional yardage may be requested.

Test samples must be sent to:

KI
Attn: C.O.M. Specialist
1687 Westminster Drive - Gate 3
Green Bay, WI 54302

Fabric Disclaimer

Fabric will be applied as swatched by the fabric manufacturer. Fabric that is required to be applied differently than is swatched will need a Special Cost Request written specifying the direction the fabric is to be applied. The posted standard lead time will apply to the Special Cost Request.

INFORMATION

Warranty

Refer to KI Terms & Conditions document or visit ki.com

Stack/Nesting

Versa® Basic Color Options

Frame Color

| | |
|--------------|----|
| Antique Vein | AV |
| Black | BL |
| Blue Grey | GR |
| Chrome | CH |
| Cool Grey | CG |
| Flannel | FN |
| Light Tone | LG |
| Mardi Gras | MG |
| Misty Brown | MY |
| Nemo | NE |
| Nickel Vein | NK |
| Nordic | ND |
| Purple Haze | PH |
| Rubber Ducky | RK |
| Sand | SA |
| Surf's Up | SP |
| Ultra Blue | UB |
| Warm Grey | WG |
| Wet Sand | WS |
| Zesty Lime | ZL |

Plastic back shell will be monochromatic with the frame if BL, WG, GR, or SA are specified. All other frame colors will have a BL back shell.

BL back shell is available in flame-retardant material for compliance to California Technical Bulletin 133.

Finish Cards

View color swatches for items listed within this document.

Paints

Wood/Veneer

Molded Edges

Hard Plastics

Plastics/Poly

Laminates



Edge Styles

Glass



Stack/Nesting

Versa® Basic

| | MODEL | Features | MODEL NUMBER | | | | Approx. Packaged Weight | Delivered Pricing |
|--|---|-------------|--------------|--------------------------|---|--------------------------|-------------------------|-------------------|
| | | | Basic Model | Frame Color | Upholstery Color | Fire Code | | |
|  VBUP | Four-Leg Arm Chair • Back and seat are foam cushioned and upholstered • Plastic back shroud • Round tubular steel frame • "Kick back" rear leg style enhances stability • Continuous steel tubular arms • Stacking | Upholstered | VBWAL | <input type="checkbox"/> | <input type="checkbox"/> <input type="checkbox"/> <input type="checkbox"/> <input type="checkbox"/> | <input type="checkbox"/> | 20.0# | N/A |
|  VBUP | Four-Leg Armless Chair • Back and seat are foam cushioned and upholstered • Plastic back shroud • Round tubular steel frame • "Kick back" rear leg style enhances stability • Stacking | Upholstered | VBNAL | <input type="checkbox"/> | <input type="checkbox"/> <input type="checkbox"/> <input type="checkbox"/> <input type="checkbox"/> | <input type="checkbox"/> | 18.0# | N/A |
|  HRDPT | Versa® Basic Transport Dolly | | VBD.BL | | | | 19.0# | \$ 485 |
| | | | | A | B | C | D | |

HOW TO ORDER

Indicate the following information on order form:

- Quantity of each item.
- Model number, including options. See "How To Build a Model Number".
- Any special service required.

Note: • The indicates that a choice is required.

- The absence of the indicates that no choice is required.
- Alpha-numeric characters in place of indicate that no other alternatives are available.

HOW TO BUILD A MODEL NUMBER

- A** Select basic model.
- B** Select frame color.
Refer to the **Product Color Options** page in this price list.
- C** Select upholstery grade/color.
Refer to ki.com/fabrics
- D** Select fire code.

| | |
|-----|-----------------------------|
| NFR | - Compliance to TB 117-2013 |
| FR | - Compliance to TB 133 |



| Delivered Pricing Fabric Grade 1 & C.O.M. | Delivered Pricing Fabric Grade 2 | Delivered Pricing Fabric Grade 3 | Delivered Pricing C.O.V. | Delivered Pricing Vinyl Group 2V | Delivered Pricing Pallas Fabric Group P0 | Delivered Pricing Pallas Fabric Group P1 | Delivered Pricing Pallas Fabric Group P2 | Delivered Pricing Pallas Fabric Group P3 | Delivered Pricing Pallas Fabric Group P4 |
|---|----------------------------------|----------------------------------|--------------------------|----------------------------------|--|--|--|--|--|
| \$ 371 | \$ 408 | \$ 409 | \$ 371 | \$ 409 | \$ 409 | \$ 420 | \$ 461 | \$ 495 | \$ 534 |
| \$ 341 | \$ 376 | \$ 382 | \$ 341 | \$ 382 | \$ 378 | \$ 390 | \$ 430 | \$ 467 | \$ 506 |

UPHOLSTERY INFORMATION
C.O.M. Upholstery

C.O.M. requirement for 10 chairs or less is 1 yd. of 54" wide nondirectional fabric and vinyls. For orders of 11 or more chairs and for complete information on ordering C.O.M., see "Ordering C.O.M., C.O.V. and C.O.L." section.

OPTIONS
California TB133 Fire Safety Code

For California Technical Bulletin 133 compliant models, add the following upcharge:

Model=Upholstered
 Added Lead Time=1 week
 Added list price=\$82

SPECIAL SERVICES
Special Carton Marking

With specially marked information N/C

Shipping

Ships **assembled, FOB Green Bay, WI 54302, freight prepaid.** Freight class 125.

Specifications and prices are subject to change without prior notice.

Stack/Nesting

Versa® Conference General Information



Conference Arm Chair
(VCWAL)



Conference Armless Chair
(VCNAL)



Transport Dolly
(MVP.BL)

Features

| | | |
|-----------|---|---|
| Stackable | • | • |
| Ganging | • | |

General Dimensions

| | | |
|-------------|---------|---------|
| Seat width | 17-3/4" | 17-3/4" |
| Seat depth | 19-1/2" | 19-1/2" |
| Seat height | 17-1/2" | 17-1/2" |

Overall Dimensions

| | | | |
|-------------------|---------|---------|---------|
| Width | 23-7/8" | 20-1/4" | 22-3/8" |
| Depth | 23-7/8" | 23-7/8" | 25-5/8" |
| Height | 32-3/4" | 32-3/4" | |
| Arms to floor | 25-5/8" | | |
| Ganging on center | 24-3/8" | | |

Stacking on Dolly

| | | |
|-----------------|-----------------------|-----------------------|
| Overall width | 23-7/8" | 22-1/2" |
| Overall depth | 37" | 37" |
| Quantity/height | 8 Chairs/56-3/4" High | 8 Chairs/54-1/2" High |

Stacking on Floor

| | | |
|-----------------|-------------------|-------------------|
| Width | 20-1/2" | 20-1/2" |
| Depth | 29-1/2" | 29-1/2" |
| Quantity/height | 4 Chairs/41" High | 4 Chairs/41" High |



Ganging



Kick Back Leg



Upholstered Back

SPECIFICATIONS

Frame

Four-leg and with arm sled models have legs made of 1" o.d. x 16-gauge tubular steel. Armless sled base models have legs made of 1" o.d. x 14-gauge tubular steel. "Kick back" rear legs on all models will increase structural integrity and add to stability. Seat side supports and cross members of 1" o.d. x 14-gauge tubular steel. Legs will be joined to side members by brazing. All other joints will be robotically welded.

Frame Finishes

30 sheen epoxy powder coating is electrostatically applied. The dry coating is then fused and cured in a baking oven to form a smooth, continuous film. Finish is chemical resistant, hard, touch and mar resistant. Bright chrome surfaces are duplex nickel-chrome plated in a twenty-two step process.

Floor Glides

Chrome plated steel or plastic and are pressed into the bottom of the leg tubes. Plastic glides match the color of the frame unless frame is chrome or hammertone, then black.

Armrest

Molded nylon and are pressed into the leg tubes.

Tube End Caps (Armless Chair)

Molded plastic. The end cap will match the frame color. With chrome and hammertone frames, the end caps will be black.

Ganging Fixtures (Armchairs Only)

Welded steel construction and chrome-plated for durability. Gangers are attached to the underside of the arms with two screws. Only armchairs can be ganged. Gangers are shipped unassembled (KD).

Upholstered Seat

Seat board is made of 7 ply compound molded plywood (3/8" thick) that is glued to a 1-1/2" thick urethane foam cushion. Fabric is glued to the foam and C-Gex upholstered. Seat is fastened to the frame with four 10-24 screws that thread into T-nuts embedded in the seat board.

Upholstered Backrest

Two-piece construction. Inner back is 7-ply compound molded plywood (7/16" thick) with 1-1/2" thick urethane foam cushion that is covered in fabric and C-Gex upholstered together. Outer back shroud is 3-ply compound molded plywood (3/16" thick) with 1/4" thick urethane foam cushion that is covered in fabric and C-Gex upholstered together. The inner back is attached to the frame with four 1/4" screws and the outer back is attached to the inner back and frame with 5 steel spring clips and 2 steel rivets.

Stacking Vinyl, Polyurethane, and Imitation Leather Upholstered Chairs

It is recommended that chairs to be stacked be covered in material other than vinyl, polyurethane, or imitation leather as an impression in the seat may result. KI does not warrant the effects of stacking on stock or C.O.M. vinyl, polyurethane, or imitation leather upholstery.

Transport Dolly

Tubular steel frame, black powder-coated finish. Four 5" wheels, two fixed and two swivel.



INFORMATION

C.O.M. Testing and Production Requirements

Not all materials are suitable for upholstering this product. A 1 yd. x 54" sample must be submitted and approved prior to acceptance of an order. If the fabric is directional in pattern or weave, the direction must be indicated on the submitted sample, and additional yardage may be requested.

Test samples must be sent to:

KI
Attn: C.O.M. Specialist
1687 Westminster Drive - Gate 3
Green Bay, WI 54302

Fabric Disclaimer

Fabric will be applied as swatched by the fabric manufacturer. Fabric that is required to be applied differently than is swatched will need a Special Cost Request written specifying the direction the fabric is to be applied. The posted standard lead time will apply to the Special Cost Request.

INFORMATION

Warranty

Refer to KI Terms & Conditions document or visit ki.com

Stack/Nesting

Versa® Conference Color Options

Frame Color

| | |
|--------------|----|
| Antique Vein | AV |
| Black | BL |
| Blue Grey | GR |
| Chrome | CH |
| Cool Grey | CG |
| Flannel | FN |
| Light Tone | LG |
| Mardi Gras | MG |
| Misty Brown | MY |
| Nemo | NE |
| Nickel Vein | NK |
| Nordic | ND |
| Purple Haze | PH |
| Rubber Ducky | RK |
| Sand | SA |
| Surf's Up | SP |
| Ultra Blue | UB |
| Warm Grey | WG |
| Wet Sand | WS |
| Zesty Lime | ZL |

When frame colors CH, AV, or NK, are is BL. For all other colors, arm matches frame.

Finish Cards

View color swatches for items listed within this document.

Paints

Wood/Veneer

Molded Edges

Hard Plastics

Plastics/Poly

Laminates

Edge Styles

Glass





| Delivered Pricing Fabric Grade 1 & C.O.M. | Delivered Pricing Fabric Grade 2 | Delivered Pricing Fabric Grade 3 | Delivered Pricing C.O.V. | Delivered Pricing Vinyl Group 2V | Delivered Pricing Pallas Fabric Group P0 | Delivered Pricing Pallas Fabric Group P1 | Delivered Pricing Pallas Fabric Group P2 | Delivered Pricing Pallas Fabric Group P3 | Delivered Pricing Pallas Fabric Group P4 |
|---|----------------------------------|----------------------------------|--------------------------|----------------------------------|--|--|--|--|--|
| \$ 657 | \$ 700 | \$ 706 | \$ 657 | \$ 706 | \$ 713 | \$ 782 | \$ 866 | \$ 944 | \$ 1022 |
| 649 | 687 | 694 | 649 | 694 | 700 | 769 | 857 | 933 | 1012 |

UPHOLSTERY INFORMATION

C.O.M. Upholstery

C.O.M. requirement for 10 chairs or less is 1-1/2 yards per chair of 54" wide nondirectional fabric. For orders of 11 or more chairs and for complete information on ordering C.O.M., see "Ordering C.O.M., C.O.V. and C.O.L." section.

INFORMATION

Note:

There are 2 wood and upholstered back styles to choose from:
 Round Back = VRB
 Square Back = VSB

OPTIONS

California TB133 Fire Safety Code

For California Technical Bulletin 133 compliant models, add the following upcharge:

Model=Conference
 Added Lead Time=1 week
 Added list price=\$82

Round Back chairs with both FR and vinyl together must be ordered as a Special.

SPECIAL SERVICES

Special Carton Marking

With specially marked information N/C



Shipping

Ships **assembled, FOB Green Bay, WI 54302, freight prepaid.** Freight class 125.

Specifications and prices are subject to change without prior notice.

Stack/Nesting

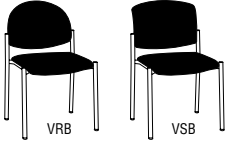
Versa® Conference

| | MODEL | Features | MODEL NUMBER | | | | | | Approx. Packaged Weight |
|--|--|--------------------------|--------------|--------------------------|---|--------------------------|--------------------------|--|-------------------------|
| | | | Basic Model | Frame Color | Upholstery Color | Fire Code | Glide Option | Back Style | |
|  VRB VSB VCUP | Four-Leg Armless Chair <ul style="list-style-type: none"> • Generously proportioned seat and back have thick foam cushioning and are upholstered • Back is fully upholstered • Brackets attaching back to frame are concealed • Round tubular steel frame • "Kick back" rear leg style enhances stability • Powder-coated or chrome plated frames | Upholstered, Non-Ganging | VCNAL | <input type="checkbox"/> | <input type="checkbox"/> <input type="checkbox"/> <input type="checkbox"/> <input type="checkbox"/> | <input type="checkbox"/> | <input type="checkbox"/> | <input type="checkbox"/> <input type="checkbox"/> <input type="checkbox"/> | 23.0# |
|  HRDPT | Versa® Transport Dolly <ul style="list-style-type: none"> • Accommodates up to 8 conference stacking chairs • Easy maneuverability with 5" casters; two fixed, two swivel • Rugged weld tubular steel frame • Black powder-coated finish | | MVP.BL | | | | | | 19.0# |
| | | | A | B | C | D | E | F | |

HOW TO ORDER

Indicate the following information on order form:

1. Quantity of each item.
2. Model number, including options. See "How To Build a Model Number".
3. Any special service required.

Note: • The indicates that a choice is required.

- The absence of the indicates that no choice is required.
- Alpha-numeric characters in place of indicate that no other alternatives are available.

HOW TO BUILD A MODEL NUMBER

- A** Select basic model.
- B** Select frame color.
Refer to the **Product Color Options** page in this price list.
End caps will match frame color, unless frame is chrome or hammertone (then black).
- C** Select upholstery grade/color.
Refer to ki.com/fabrics
- D** Select fire code.
NFR - Compliance to TB 117-2013
FR - Compliance to TB 133
- E** Select glide option.
P - Plastic glides
S - Steel glides (standard)
- F** Select back style.
VRB - Round (original style)
VSB - Square (new style)



| Delivered Pricing Upholstered | Delivered Pricing Fabric Grade 1 & C.O.M. | Delivered Pricing Fabric Grade 2 | Delivered Pricing Fabric Grade 3 | Delivered Pricing C.O.V. | Delivered Pricing Vinyl Group 2V | Delivered Pricing Pallas Fabric Group P0 | Delivered Pricing Pallas Fabric Group P1 | Delivered Pricing Pallas Fabric Group P2 | Delivered Pricing Pallas Fabric Group P3 | Delivered Pricing Pallas Fabric Group P4 |
|-------------------------------|---|----------------------------------|----------------------------------|--------------------------|----------------------------------|--|--|--|--|--|
| N/A | \$ 615 | \$ 657 | \$ 660 | \$ 615 | \$ 660 | \$ 670 | \$ 737 | \$ 827 | \$ 901 | \$ 982 |

\$ 471

UPHOLSTERY INFORMATION

C.O.M. Upholstery

C.O.M. requirement for 10 chairs or less is 1-1/2 yards per chair of 54" wide nondirectional fabric. For orders of 11 or more chairs and for complete information on ordering C.O.M., see "Ordering C.O.M., C.O.V. and C.O.L." section.

INFORMATION

Note:

There are 2 wood and upholstered back styles to choose from:
Round Back = VRB
Square Back = VSB

OPTIONS

California TB133 Fire Safety Code
For California Technical Bulletin 133 compliant models, add the following upcharge:

Model=Conference
Added Lead Time=1 week
Added list price=\$82

Round Back chairs with both FR and vinyl together must be ordered as a Special.

SPECIAL SERVICES

Special Carton Marking

With specially marked information N/C

Shipping

Ships **assembled, FOB Green Bay, WI 54302, freight prepaid.** Freight class 125.

Specifications and prices are subject to change without prior notice.

Stack/Nesting

Versa® Standard General Information



**Standard Four-Leg
Arm Chair
(96WAL)**



**Four-Leg Armless Chair
(96NAL)**



**Round Wood Four-Leg
Armless Chair
(15NALW)**



**Standard Four-Leg
Tablet Arm Chair
(96TAR)**

| Features | | | | |
|---------------------|--------------------|--------------------|-------------------|---------|
| Stackable | • | • | • | |
| Ganging | • | • | • | |
| General Dimensions | | | | |
| Seat width | 17-1/2" | 17-1/2" | 16-15/16" | 17-1/2" |
| Seat depth | 17-1/2" | 17-1/2" | 17-1/2" | 17-1/2" |
| Seat height | 17-1/2" | 17-1/2" | 16-1/8" | 17-1/2" |
| Overall Dimensions | | | | |
| Width | 22-5/8" | 19-3/8" | 19-1/8" | 21-3/4" |
| Depth | 20-3/4" | 20-3/4" | 20-3/4" | 27-1/4" |
| Height | 31" | 31" | 31" | 31" |
| Ganging on center | 23-1/2" | 23-1/2" | 23-1/2" | |
| Top of arm to floor | 25-3/8" | | | |
| Stacking on Dolly | | | | |
| Overall width | 22-3/8" | 22-3/8" | 22-3/8" | |
| Overall depth | 36" | 36" | 36" | |
| Quantity/height | 10 Chairs/60" High | 10 Chairs/54" High | 8 Chairs/60" High | |
| Stacking on Floor | | | | |
| Width | 22-5/8" | 19-3/8" | 22-5/8" | |
| Depth | 25-1/4" | 25-1/4" | 25-1/4" | |
| Quantity/height | 4 Chairs/40" High | 4 Chairs/40" High | 4 Chairs/40" High | |



Ganging



Kick Back Leg

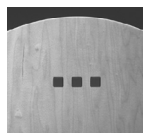

**C01 Square Cut-outs
(Round Back)**

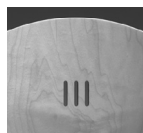

**C02 Ellipse Cut-outs
(Round Back)**

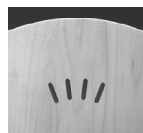

**C03 Starburst Cut-outs
(Round Back)**



**C04 Fan Cut-outs
(Square Back)**

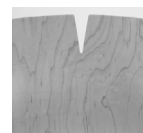

**C05 Split Cut-outs
(Square Back)**

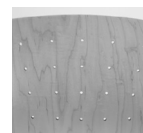

**C06 Perforated Cut-outs
(Square Back)**

SPECIFICATIONS

Standard Frame

Legs of 7/8" o.d. x 13-gauge tubular steel. "Kick back" rear legs on four-leg model increases structural integrity and adds to stability. Side members of 7/8" o.d. x 13-gauge tubular steel. Cross tube members of 7/8" o.d. x 14-gauge tubular steel. Legs are joined to side members by brazing; all other joints are robotically welded.

Frame Finishes

Baked-on, electrostatically-applied epoxy powder coating, or bright nickel-chrome plated.

Ganging Fixture

Welded steel rod. Armrest models have separate fixture that can be installed with screws to underside of arms (shipped k.d.). Armless models have fixture welded to frame.

Standard Tube End Caps

Molded plastic. The end cap will match the frame color. With chrome frames, the end cap will be black (upholstered and wood chairs).

Four-Leg Floor Glides

Three optional glide types are available for leg chairs: swivel poly/nylon, swivel steel and swivel felt glides. The swivel function allows the bottom of the glide to correctly match un-even floor conditions, resulting in less wear. Poly/nylon and felt glides are interchangeable and have easy-on/easy-off replaceable glide caps, which makes field replacement easy and efficient. Swivel poly glides are available in Stone color only.

Sled Base Non-Skid Glides

Black PVC material. Fixed in position by a screw. Field-installable.

Armrests

Molded nylon or chrome-plated aluminum (for non-ganging models).

Tablet Arm Chair

Tablet of resin core with laminate writing surface and backing sheet. Round tablet edge with clear lacquer finish. Available in left- or right-hand models. Nonstacking. Seating clearance is 14". Tablet is 20-5/8" long and 12" wide.

Upholstered Seat

3/8" thick polypropylene. Fastens to frame with four screws through T-nuts embedded in seat. Polyfoam cushion 3/4" thick glued to seat.

Upholstered Backrest

Two-piece construction. Inner back is polypropylene with 3/4" thick polyurethane foam. Outer back is a polypropylene back insert with 1/4" thick polyurethane foam and three back clips (.018" thick cold-rolled annealed spring steel).

Wood Seat and Backrest

Backs are constructed of 9-ply hard maple with "A Grade" flat cut faces. Seats are

constructed of 3/8" hard maple. Wood seats and backs are available in maple with "A Grade" flat cut faces. Seats and backs are assembled with four ribbed carriage bolts and low profile screws with black oxide-plated finish. Stacking version has 4 plastic bumpers that protect seat. Caution needs to be used when stacking.

Stacking Vinyl, Polyurethane, and Imitation Leather Upholstered Chairs

It is recommended that chairs to be stacked be covered in material other than vinyl, polyurethane, or imitation leather as an impression in the seat may result. KI does not warrant the effects of stacking on stock or C.O.M. vinyl, polyurethane, or imitation leather upholstery.

Standard Transport Dolly

Tubular steel frame, black powder-coated finish. Four 5" swivel wheels.

Wallsaver Transport Dolly

Available via Special Cost Request.



**Standard Sled Base
Arm Chair
(96WAS)**



**Standard Sled Base
Armless Chair
(96NAS)**



**Square Wood Sled Base
Armless Chair
(15NASW)**

Features

Stackable

Ganging

•

•

•

General Dimensions

Seat width

17-1/2"

17-1/2"

16-15/16"

Seat depth

17-1/2"

17-1/2"

17-1/2"

Seat height

17-1/2"

17-1/2"

16-1/8"

Overall Dimensions

Width

22-5/8"

19-3/8"

19-1/8"

Depth

20-3/4"

20-3/4"

20-3/4"

Height

31"

31"

31"

Ganging on center

23-1/2"

23-1/2"

23-1/2"

Top of arm to floor

25-3/8"

Stacking on Dolly

Overall width

Overall depth

Quantity/height

Stacking on Floor

Width

Depth

Quantity/height

INFORMATION

C.O.M. Testing and Production Requirements

Not all materials are suitable for upholstering this product. A 1 yd. x 54" sample for standard models and full back models must be submitted and approved prior to acceptance of an order. If the fabric is directional in pattern or weave, the direction must be indicated on the submitted sample, and additional yardage may be requested.

Test samples must be sent to:

KI
Attn: C.O.M. Specialist
1687 Westminster Drive - Gate 3
Green Bay, WI 54302

Fabric Disclaimer

Fabric will be applied as swatched by the fabric manufacturer. Fabric that is required to be applied differently than is swatched will need a Special Cost Request written specifying the direction the fabric is to be applied. The posted standard lead time will apply to the Special Cost Request.

INFORMATION

Warranty

Refer to KI Terms & Conditions document or visit ki.egm

Stack/Nesting

Versa® Standard General Information



Standard Four-Leg Wallsaver Arm Chair (96WALWS)



Upholstered Seat/Wood Back Four-Leg Arm Chair (15WALUW)



Armless Upholstered Seat/Wood Back Sled Base Chair (15NASGUW)



Standard Transport Dolly (MVP.BL)

| Features | | | | |
|---------------------|--------------------------|--------------------|---------|---------|
| Stackable | • | • | | |
| Ganging | • | • | • | |
| General Dimensions | | | | |
| Seat width | 17-1/2" | 17-1/2" | 17-1/2" | |
| Seat depth | 17-1/2" | 17-1/2" | 17-1/2" | |
| Seat height | 17-1/2" | 17-1/2" | 17-1/2" | |
| Overall Dimensions | | | | |
| Width | 22-5/8" | 22-5/8" | 19-3/8" | 22-3/8" |
| Depth | 21-3/4" | 20-3/4" | 20-3/4" | 25-5/8" |
| Height | 31" | 31" | 31" | |
| Ganging on center | 23-1/2" | | | |
| Top of arm to floor | 25-3/8" | 25-3/8" | | |
| Stacking on Dolly | | | | |
| | See Specifications Below | | | |
| Overall width | | 22-3/8" | | |
| Overall depth | | 36" | | |
| Quantity/height | | 10 Chairs/60" High | | |
| Stacking on Floor | | | | |
| Width | 22-5/8" | 22-5/8" | | |
| Depth | 26-1/4" | 25-1/4" | | |
| Quantity/height | 4 Chairs/40" High | 4 Chairs/40" High | | |



Ganging



Kick Back Leg

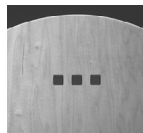

C01 Square Cut-outs (Round Back)

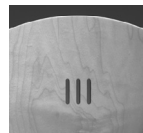

C02 Ellipse Cut-outs (Round Back)



C03 Starburst Cut-outs (Round Back)



C04 Fan Cut-outs (Square Back)

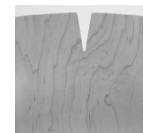

C05 Split Cut-outs (Square Back)

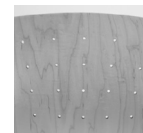

C06 Perforated Cut-outs (Square Back)

SPECIFICATIONS

Standard Frame

Legs of 7/8" o.d. x 13-gauge tubular steel. "Kick back" rear legs on four-leg model increases structural integrity and adds to stability. Side members of 7/8" o.d. x 13-gauge tubular steel. Cross tube members of 7/8" o.d. x 14-gauge tubular steel. Legs are joined to side members by brazing; all other joints are robotically welded.

Stool

Legs of 7/8" o.d. x 13-gauge tubular steel. Side members of 7/8" o.d. x 13-gauge tubular steel. Cross tube members of 7/8" o.d. x 14-gauge tubular steel. Legs are joined to side members by brazing; all other joints are hand welded. The footring is 7/8" outside diameter steel wire.

Frame Finishes

Baked-on, electrostatically-applied epoxy powder coating, or bright nickel-chrome plated.

Standard Tube End Caps

Molded plastic. The end cap will match the frame color. With chrome frames, the end cap will be black (upholstered and wood chairs).

Armrests

Molded nylon or chrome-plated aluminum (for non-ganging models).

Four-Leg Floor Glides

Chrome plated steel or plastic.

Sled Base Non-Skid Glides

Black PVC material. Fixed in position by a screw. Field-installable.

Ganging Fixture

Welded steel rod. Armrest models have separate fixture that can be installed with screws to underside of arms (shipped k.d.). Armless models have fixture welded to frame.

Upholstered Seat

3/8" thick polypropylene. Fastens to frame with four screws through T-nuts embedded in seat. Polyfoam cushion 3/4" thick glued to seat.

Upholstered Backrest

Two-piece construction. Inner back is polypropylene with 3/4" thick polyurethane foam. Outer back is a polypropylene back insert with 1/4" thick polyurethane foam and three back clips (.018" thick cold-rolled annealed spring steel).

Upholstered Square Back

Two-piece construction. Inner back is 11-ply hard maple (.44 thick) with 3/4" thick urethane foam. The outer back is 3-ply gum veneer (.19 thick) with 1/4" urethane foam. Both inner and outer back boards have formed contours. The outer back is attached to the inner back with (3) spring steel clips. The back assembly is attached to the frame with (4) 1/4"-20 screws.

Wood Seat and Backrest

Seats are constructed of 9-ply hard maple with "A Grade" flat cut faces. Seats are constructed of 3/8" hard maple. Wood seats and backs are available in maple with "A Grade" flat cut faces. Seats and backs are assembled with four ribbed carriage bolts and low profile screws with black oxide-plated finish. Stacking version has 4 plastic bumpers that protect seat. Caution needs to be used when stacking.

Stacking Vinyl, Polyurethane, and Imitation Leather Upholstered Chairs

It is recommended that chairs to be stacked be covered in material other than vinyl, polyurethane, or imitation leather as an impression in the seat may result. KI does not warrant the effects of stacking on stock or C.O.M. vinyl, polyurethane, or imitation leather upholstery.



**Upholstered Cafe Stool
with Arms
(S96WAL)**

Features

Stackable

Ganging

General Dimensions

Seat width 17-1/2"

Seat depth 17-1/2"

Seat height 29-1/2"

Overall Dimensions

Width 22-5/8"

Depth 22-3/8"

Height 43"

Top of arm to floor 37-3/8"

Standard Transport Dolly

Tubular steel frame, black powder-coated finish. Four 5" swivel wheels.

Wallsaver Transport Dolly

Available via Special Cost Request.

INFORMATION

C.O.M. Testing and Production Requirements

Not all materials are suitable for upholstering this product. A 1 yd. x 54" sample for standard models and full back models must be submitted and approved prior to acceptance of an order. If the fabric is directional in pattern or weave, the direction must be indicated on the submitted sample, and additional yardage may be requested.

Test samples must be sent to:

KI
Attn: C.O.M. Specialist
1687 Westminster Drive - Gate 3
Green Bay, WI 54302

Fabric Disclaimer

Fabric will be applied as swatched by the fabric manufacturer. Fabric that is required to be applied differently than is swatched will need a Special Cost Request written specifying the direction the fabric is to be applied. The posted standard lead time will apply to the Special Cost Request.

INFORMATION

Warranty

Refer to KI Terms & Conditions document or visit ki.com

Stack/Nesting

Versa® Standard Color Options

Frame Color

| | |
|--------------|----|
| Antique Vein | AV |
| Black | BL |
| Blue Grey | GR |
| Chrome | CH |
| Cool Grey | CG |
| Flannel | FN |
| Light Tone | LG |
| Mardi Gras | MG |
| Misty Brown | MY |
| Nemo | NE |
| Nickel Vein | NK |
| Nordic | ND |
| Purple Haze | PH |
| Rubber Ducky | RK |
| Sand | SA |
| Surf's Up | SP |
| Ultra Blue | UB |
| Warm Grey | WG |
| Wet Sand | WS |
| Zesty Lime | ZL |

When frame color is CH on Versa poly, arm matches poly color. When frame color is AV or NK on Versa poly, arm is BL.

When frame color is CH, AV and NK on Versa upholstered or wood, arm is BL. For all other colors, arm matches frame.

Wood Seat/Back Finish - Core

| | |
|---------------------------|-----|
| Cherry Storm on Maple | MCX |
| Cinnamon on Maple | MCN |
| Cocoa on Maple | MCA |
| Florence Walnut on Maple | MFC |
| Kensington Maple on Maple | MMA |
| Monticello Maple on Maple | MMT |
| River Cherry on Maple | MRY |

All stain colors are acceptable for CA 133.

Tablet Arm Color - Laminate

Flip and G-Tablet

| | |
|--------------------|-----|
| Biltmore Cherry | LBT |
| Black | LBK |
| Brighton Walnut | LBW |
| Canyon Zephyr | LCA |
| Castle Oak | LCO |
| Casual Linen | LCU |
| Cherry Storm | LCX |
| Classic Linen | LCI |
| Cloud Zephyr | LCL |
| Cocobala | LCC |
| Coffee Bean | LCB |
| Crisp Linen | LRI |
| Desert Zephyr | LDZ |
| Dove Grey | LDG |
| Fired Steel | LIL |
| Flax Linen | LXF |
| Florence Walnut | LFC |
| Forged Steel | LOL |
| Frosty White | LFW |
| Graphite Nebula | LGN |
| Grey | LGE |
| High Rise | LHE |
| Hollyberry | LHY |
| Irish Linen | LIH |
| Island | LID |
| Italian Silver Ash | LIT |
| Kensington Maple | LKM |
| Lapis Blue | LLB |
| Markerboard White | LMK |
| Misted Zephyr | LMR |
| Monticello Maple | LMT |
| Nickel Evolv | LNV |
| North Sea | LNA |
| Ocean | LON |
| Orange Grove | LOE |
| Pearl Bisque | LPB |
| Pearl Silver | LPS |
| Pressed Linen | LPR |
| River Cherry | LRV |
| Rugged Linen | LRG |
| Satin Stainless | LSS |
| Shadow Zephyr | LSR |
| Silicon evolv | LSV |
| Sterling Ash | LAZ |
| Tailored Linen | LTL |
| Titanium evolv | LTV |
| White Nebula | LWL |
| White Sand | LWN |
| Windsor Mahogany | LWY |

Finish Cards

View color swatches for items listed within this document.

Paints

Wood/Veneer

Molded Edges

Hard Plastics

Plastics/Poly

Laminates

Edge Styles

Glass



Stack/Nesting

Versa® Standard

| | | MODEL NUMBER | | | | | | | | | Approx. Packaged Weight |
|---|-------------------|--------------|--------------------------|--------------------------|--------------------------|--------------------------|--------------------------|--------------------------|--------------------------|--------------------------|-------------------------|
| | | Basic Model | Frame Color | Wood Seat and Back Color | Upholstery Color | Fire Code | Glide Option | Back Style | Wood Back Cut-outs | Wood Stacking Option | |
| <p>VRB</p> <p>VSB</p> <p>VRWD</p> <p>VRUP</p> <p>Four-Leg Armless Chair</p> <ul style="list-style-type: none"> • Back and seat are foam cushioned/upholstered or wood • Round tubular steel frame • "Kick back" rear leg style enhances stability • Ganger welded to frame and finished to match frame • Stacking | Wood, Ganging | 15NAGW | <input type="checkbox"/> | <input type="checkbox"/> | | | <input type="checkbox"/> | <input type="checkbox"/> | <input type="checkbox"/> | <input type="checkbox"/> | 18.0# |
| | Wood, Non-Ganging | 15NALW | <input type="checkbox"/> | <input type="checkbox"/> | | | <input type="checkbox"/> | <input type="checkbox"/> | <input type="checkbox"/> | <input type="checkbox"/> | 18.0# |
| | Uph, Ganging | 96NAG | <input type="checkbox"/> | | <input type="checkbox"/> | <input type="checkbox"/> | <input type="checkbox"/> | <input type="checkbox"/> | | | 19.0# |
| | Uph, Non-Ganging | 96NAL | <input type="checkbox"/> | | <input type="checkbox"/> | <input type="checkbox"/> | <input type="checkbox"/> | | | | 19.0# |
| <p>VRB</p> <p>VSB</p> <p>VRWD</p> <p>VRUP</p> <p>Four-Leg Wallsaver Armless Chair</p> <ul style="list-style-type: none"> • Back and seat are foam cushioned/upholstered or wood • Round tubular steel frame • Ganger welded to frame and finished to match frame • Stacking • Wallsaver rear legs touch base of wall preventing chair back from contacting wall | Wood, Ganging | 15NAGWWS | <input type="checkbox"/> | <input type="checkbox"/> | | | S | <input type="checkbox"/> | <input type="checkbox"/> | <input type="checkbox"/> | 18.0# |
| | Wood, Non-Ganging | 15NALWWS | <input type="checkbox"/> | <input type="checkbox"/> | | | S | <input type="checkbox"/> | <input type="checkbox"/> | <input type="checkbox"/> | 18.0# |
| | Uph, Ganging | 96NAGWS | <input type="checkbox"/> | | <input type="checkbox"/> | <input type="checkbox"/> | S | <input type="checkbox"/> | | | 19.0# |
| | Uph, Non-Ganging | 96NALWS | <input type="checkbox"/> | | <input type="checkbox"/> | <input type="checkbox"/> | S | <input type="checkbox"/> | | | 19.0# |
| | | A | B | C | D | E | F | G | H | I | |

HOW TO ORDER

Indicate the following information on order form:

- Quantity of each item.
- Model number, including options. See "How To Build a Model Number".
- Any special service required.

Note: • The indicates that a choice is required.

- The absence of the indicates that no choice is required.
- Alpha-numeric characters in place of indicate that no other alternatives are available.

HOW TO BUILD A MODEL NUMBER

A Select basic model.

B Select frame color.
Refer to the **Product Color Options** page in this price list.
Arms will match frame color, unless frame is chrome or hammertone (then black).

C Select wood seat and back color.
Refer to the **Product Color Options** page in this price list.

D Select upholstery grade/color.
Refer to ki.com/fabrics

E Select fire code.
NFR - Compliance to TB 117-2013
FR - Compliance to TB 133

F Select glide option.
F - Felt Glides
P - Plastic glides
S - Steel glides (standard)

G Select back style.
VRB - Round (original style)
VSB - Square (new style)

H Select wood back cut-out.
C01 - Square (round back only)
C02 - Ellipse (round back only)
C03 - Starburst (round back only)
C04 - Fan (square back only)
C05 - Split (square back only)
C06 - Perforated (square back only)
NC - No cut-out (both styles)

I Select wood stacking option.
NS - Nonstacking bumper
SB - Stacking bumper



| Delivered Pricing Upholstered | Delivered Pricing Fabric Grade 1 & C.O.M. | Delivered Pricing Fabric Grade 2 | Delivered Pricing Fabric Grade 3 | Delivered Pricing C.O.V. | Delivered Pricing Vinyl Group 2V | Delivered Pricing Pallas Fabric Group P0 | Delivered Pricing Pallas Fabric Group P1 | Delivered Pricing Pallas Fabric Group P2 | Delivered Pricing Pallas Fabric Group P3 | Delivered Pricing Pallas Fabric Group P4 |
|-------------------------------|---|----------------------------------|----------------------------------|--------------------------|----------------------------------|--|--|--|--|--|
| \$ 669 | | | | | | | | | | |
| 645 | | | | | | | | | | |
| N/A | 511 | 546 | 547 | 511 | 547 | 545 | 556 | 595 | 632 | 677 |
| N/A | 483 | 520 | 521 | 483 | 521 | 517 | 527 | 567 | 606 | 648 |
| <hr/> | | | | | | | | | | |
| \$ 706 | | | | | | | | | | |
| 681 | | | | | | | | | | |
| N/A | 549 | 586 | 587 | 549 | 587 | 581 | 593 | 638 | 672 | 714 |
| N/A | 522 | 560 | 561 | 522 | 561 | 556 | 567 | 607 | 646 | 685 |

INFORMATION

Note:

There are 2 wood and upholstered back styles to choose from:
Round Back = VRB
Square Back = VSB

The original ROUND wood back style (RB) has the following wood cut-out options only:
C01 = Square
C02 = Ellipse
C03 = Standard
NC = No cut-out

The new SQUARE wood back style (SB) has the following wood cut-out options only:
C04 = Fan
C05 = Split
C06 = Perforated
NC = No cut-out

UPHOLSTERY INFORMATION

C.O.M. Upholstery

C.O.M. requirement 1 yard per chair of 54" wide nondirectional fabric. For complete information on ordering C.O.M., see "Ordering C.O.M., C.O.V. and C.O.L." section.

OPTIONS

California TB133 Fire Safety Code

For California Technical Bulletin 133 compliant models, add the following upcharge:

Model=Upholstered
Added Lead Time=1 week
Added list price=\$61

Round Back chairs with both FR and vinyl together must be ordered as a Special.

SPECIAL SERVICES

Special Carton Marking

With specially marked information N/C

Shipping

Ships **assembled, FOB Green Bay, WI 54302, freight prepaid.** Freight class 125.

Specifications and prices are subject to change without prior notice.

Stack/Nesting

Versa® Standard

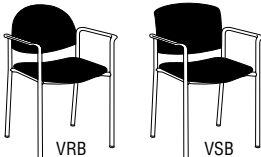
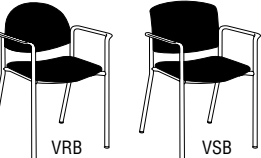
| | | MODEL NUMBER | | | | | | | | |
|---|-------------------|--------------|--------------------------|--------------------------|--------------------------|--------------------------|--------------------------|--------------------------|--------------------------|--------------------------|
| | | Basic Model | Frame Color | Wood Seat and Back Color | Upholstery Color | Glide Option | Back Style | Wood Back Cut-outs | Wood Stacking Option | Arm Option |
|  <p>VRB VSB</p> <p>VRWD VRUP</p> <p>Four-Leg Arm Chair</p> <ul style="list-style-type: none"> • Back and seat are foam cushioned/upholstered or wood • Round tubular steel frame • "Kick back" rear leg style enhances stability • Molded nylon or chrome plated (non-ganging) arms • Ganger fastened to nylon armrest • Stacking | Features | | | | | | | | | |
| | Wood, Ganging | 15WAGW | <input type="checkbox"/> | <input type="checkbox"/> | | <input type="checkbox"/> | <input type="checkbox"/> | <input type="checkbox"/> | <input type="checkbox"/> | MPA |
| | Wood, Non-Ganging | 15WALW | <input type="checkbox"/> | <input type="checkbox"/> | | <input type="checkbox"/> | <input type="checkbox"/> | <input type="checkbox"/> | <input type="checkbox"/> | <input type="checkbox"/> |
| | Uph, Ganging | 96WAG | <input type="checkbox"/> | | <input type="checkbox"/> | <input type="checkbox"/> | <input type="checkbox"/> | | | MPA |
| | Uph, Non-Ganging | 96WAL | <input type="checkbox"/> | | <input type="checkbox"/> | <input type="checkbox"/> | | | <input type="checkbox"/> | |
| | | | | | | | | | | |
|  <p>VRB VSB</p> <p>VRWD VRUP</p> <p>Four-Leg Wallsaver Arm Chair</p> <ul style="list-style-type: none"> • Back and seat are foam cushioned/upholstered or wood • Round tubular steel frame • Molded nylon or chrome plated (non-ganging) arms • Ganger fastened to nylon armrest • Stacking • Wallsaver rear legs touch base of wall preventing chair back from contacting wall surface | Features | | | | | | | | | |
| | Wood, Ganging | 15WAGWWS | <input type="checkbox"/> | <input type="checkbox"/> | | S | <input type="checkbox"/> | <input type="checkbox"/> | <input type="checkbox"/> | MPA |
| | Wood, Non-Ganging | 15WALWWS | <input type="checkbox"/> | <input type="checkbox"/> | | S | <input type="checkbox"/> | <input type="checkbox"/> | <input type="checkbox"/> | <input type="checkbox"/> |
| | Uph, Ganging | 96WAGWS | <input type="checkbox"/> | | <input type="checkbox"/> | S | <input type="checkbox"/> | | | MPA |
| | Uph, Non-Ganging | 96WALWS | <input type="checkbox"/> | | <input type="checkbox"/> | S | <input type="checkbox"/> | | <input type="checkbox"/> | |
| | | | | | | | | | | |

A B C D E F G H I

HOW TO ORDER

Indicate the following information on order form:

- Quantity of each item.
- Model number, including options. See "How To Build a Model Number".
- Any special service required.

Note: • The indicates that a choice is required.

- The absence of the indicates that no choice is required.
- Alpha-numeric characters in place of indicate that no other alternatives are available.

HOW TO BUILD A MODEL NUMBER

A Select basic model.

B Select frame color.
Refer to the **Product Color Options** page in this price list.

C Select wood seat and back color.
Refer to the **Product Color Options** page in this price list.

D Select upholstery grade/color.
Refer to ki.com/fabrics

E Select fire code.
NFR - Compliance to TB 117-2013
FR - Compliance to TB 133

F Select glide option.
F - Felt Glides
P - Plastic glides
S - Steel glides (standard)

G Select back style.
VRB - Round (original style)
VSB - Square (new style)

H Select wood back cut-out.
CO1 - Square (round back only)
CO2 - Ellipse (round back only)
CO3 - Starburst (round back only)
CO4 - Fan (square back only)
CO5 - Split (square back only)
CO6 - Perforated (square back only)
NC - No cut-out (both styles)

I Select wood stacking option.
NS - Nonstacking bumper
SB - Stacking bumper

J Select arm option.
CHA - Chrome plated
MPA - Poly



| Approx. Packaged Weight | Delivered Pricing Unupholstered | Delivered Pricing Fabric Grade 1 & C.O.M. | Delivered Pricing Fabric Grade 2 | Delivered Pricing Fabric Grade 3 | Delivered Pricing C.O.V. | Delivered Pricing Vinyl Group 2V | Delivered Pricing Pallas Fabric Group P0 | Delivered Pricing Pallas Fabric Group P1 | Delivered Pricing Pallas Fabric Group P2 | Delivered Pricing Pallas Fabric Group P3 | Delivered Pricing Pallas Fabric Group P4 |
|-------------------------|---------------------------------|---|----------------------------------|----------------------------------|--------------------------|----------------------------------|--|--|--|--|--|
| 20.0# | \$ 681 | | | | | | | | | | |
| 19.0# | 669 | | | | | | | | | | |
| 21.0# | N/A | 522 | 560 | 561 | 522 | 561 | 556 | 567 | 608 | 646 | 685 |
| 20.0# | N/A | 511 | 546 | 547 | 511 | 547 | 545 | 556 | 595 | 632 | 677 |

| | | | | | | | | | | | |
|-------|--------|-----|-----|-----|-----|-----|-----|-----|-----|-----|-----|
| 20.0# | \$ 719 | | | | | | | | | | |
| 19.0# | 706 | | | | | | | | | | |
| 21.0# | N/A | 561 | 595 | 597 | 561 | 597 | 595 | 606 | 648 | 682 | 724 |
| 20.0# | N/A | 549 | 586 | 587 | 549 | 587 | 581 | 593 | 633 | 672 | 712 |

INFORMATION

Note:

There are 2 wood and upholstered back styles to choose from:
Round Back = VRB
Square Back = VSB

The original ROUND wood back style (RB) has the following wood cut-out options only:
C01 = Square
C02 = Ellipse
C03 = Standard
NC = No cut-out

The new SQUARE wood back style (SB) has the following wood cut-out options only:
C04 = Fan
C05 = Split
C06 = Perforated
NC = No cut-out

UPHOLSTERY INFORMATION

C.O.M. Upholstery

C.O.M. requirement 1 yard per chair of 54" wide nondirectional fabric. For complete information on ordering C.O.M., see "Ordering C.O.M., C.O.V. and C.O.L." section.

OPTIONS

California TB133 Fire Safety Code

For California Technical Bulletin 133 compliant models, add the following upcharge:

Model=Upholstered
Added Lead Time=1 week
Added list price=\$61

Round Back chairs with both FR and vinyl together must be ordered as a Special.

SPECIAL SERVICES

Special Carton Marking

With specially marked information N/C

Shipping

Ships **assembled, FOB Green Bay, WI 54302, freight prepaid.** Freight class 125.

Specifications and prices are subject to change without prior notice.



| Delivered Pricing Unupholstered | Delivered Pricing Fabric Grade 1 & C.O.M. | Delivered Pricing Fabric Grade 2 | Delivered Pricing Fabric Grade 3 | Delivered Pricing C.O.V. | Delivered Pricing Vinyl Group 2V | Delivered Pricing Pallas Fabric Group P0 | Delivered Pricing Pallas Fabric Group P1 | Delivered Pricing Pallas Fabric Group P2 | Delivered Pricing Pallas Fabric Group P3 | Delivered Pricing Pallas Fabric Group P4 |
|---------------------------------|---|----------------------------------|----------------------------------|--------------------------|----------------------------------|--|--|--|--|--|
| \$ 866 | | | | | | | | | | |
| 866 | | | | | | | | | | |
| N/A | 709 | 744 | 748 | 709 | 748 | 743 | 754 | 796 | 832 | 867 |
| N/A | 709 | 744 | 748 | 709 | 748 | 743 | 754 | 796 | 832 | 867 |

INFORMATION

Note:

There are 2 wood and upholstered back styles to choose from:
Round Back = VRB
Square Back = VSB

The original ROUND wood back style (RB) has the following wood cut-out options only:
C01 = Square
C02 = Ellipse
C03 = Standard
NC = No cut-out

The new SQUARE wood back style (SB) has the following wood cut-out options only:
C04 = Fan
C05 = Split
C06 = Perforated
NC = No cut-out

UPHOLSTERY INFORMATION

C.O.M. Upholstery

C.O.M. requirement 1 yard per chair of 54" wide nondirectional fabric. For complete information on ordering C.O.M., see "Ordering C.O.M., C.O.V. and C.O.L." section.

OPTIONS

California TB133 Fire Safety Code

For California Technical Bulletin 133 compliant models, add the following upcharge:

Model=Upholstered
Added Lead Time=1 week
Added list price=\$61

Round Back chairs with both FR and vinyl together must be ordered as a Special.

SPECIAL SERVICES

Special Carton Marking

With specially marked information N/C

Shipping

Ships **assembled, FOB Green Bay, WI 54302, freight prepaid.** Freight class 125.

Specifications and prices are subject to change without prior notice.



| Delivered Pricing Unupholstered | Delivered Pricing Fabric Grade 1 & C.O.M. | Delivered Pricing Fabric Grade 2 | Delivered Pricing Fabric Grade 3 | Delivered Pricing C.O.V. | Delivered Pricing Vinyl Group 2V | Delivered Pricing Pallas Fabric Group P0 | Delivered Pricing Pallas Fabric Group P1 | Delivered Pricing Pallas Fabric Group P2 | Delivered Pricing Pallas Fabric Group P3 | Delivered Pricing Pallas Fabric Group P4 |
|---------------------------------|---|----------------------------------|----------------------------------|--------------------------|----------------------------------|--|--|--|--|--|
| \$ 820 | | | | | | | | | | |
| 796 | | | | | | | | | | |
| N/A | 665 | 701 | 705 | 665 | 705 | 701 | 712 | 754 | 790 | 829 |
| N/A | 642 | 679 | 680 | 642 | 680 | 674 | 685 | 726 | 763 | 804 |

INFORMATION

Note:

There are 2 wood and upholstered back styles to choose from:
 Round Back = VRB
 Square Back = VSB

The original ROUND wood back style (RB) has the following wood cut-out options only:
 C01 = Square
 C02 = Ellipse
 C03 = Standard
 NC = No cut-out

The new SQUARE wood back style (SB) has the following wood cut-out options only:
 C04 = Fan
 C05 = Split
 C06 = Perforated
 NC = No cut-out

UPHOLSTERY INFORMATION

C.O.M. Upholstery

C.O.M. requirement 1 yard per chair of 54" wide nondirectional fabric. For complete information on ordering C.O.M., see "Ordering C.O.M., C.O.V. and C.O.L." section.

OPTIONS

California TB133 Fire Safety Code

For California Technical Bulletin 133 compliant models, add the following upcharge:

Model=Upholstered
 Added Lead Time=1 week
 Added list price=\$61

Round Back chairs with both FR and vinyl together must be ordered as a Special.

SPECIAL SERVICES

Special Carton Marking

With specially marked information N/C

Shipping

Ships **assembled, FOB Green Bay, WI 54302, freight prepaid.** Freight class 125.

Specifications and prices are subject to change without prior notice.



| Delivered Pricing Upholstered | Delivered Pricing Fabric Grade 1 & C.O.M. | Delivered Pricing Fabric Grade 2 | Delivered Pricing Fabric Grade 3 | Delivered Pricing C.O.V. | Delivered Pricing Vinyl Group 2V | Delivered Pricing Pallas Fabric Group P0 | Delivered Pricing Pallas Fabric Group P1 | Delivered Pricing Pallas Fabric Group P2 | Delivered Pricing Pallas Fabric Group P3 | Delivered Pricing Pallas Fabric Group P4 |
|-------------------------------|---|----------------------------------|----------------------------------|--------------------------|----------------------------------|--|--|--|--|--|
| \$ 829 | | | | | | | | | | |
| 820 | | | | | | | | | | |
| N/A | 680 | 716 | 717 | 680 | 717 | 711 | 724 | 764 | 801 | 839 |
| N/A | 665 | 701 | 705 | 665 | 705 | 701 | 712 | 754 | 790 | 829 |

\$ 471

INFORMATION

Note:

There are 2 wood and upholstered back styles to choose from:
Round Back = VRB
Square Back = VSB

The original ROUND wood back style (RB) has the following wood cut-out options only:
C01 = Square
C02 = Ellipse
C03 = Standard
NC = No cut-out

The new SQUARE wood back style (SB) has the following wood cut-out options only:
C04 = Fan
C05 = Split
C06 = Perforated
NC = No cut-out

UPHOLSTERY INFORMATION

C.O.M. Upholstery

C.O.M. requirement 1 yard per chair of 54" wide nondirectional fabric. For complete information on ordering C.O.M., see "Ordering C.O.M., C.O.V. and C.O.L." section.

OPTIONS

California TB133 Fire Safety Code

For California Technical Bulletin 133 compliant models, add the following upcharge:

Model=Upholstered
Added Lead Time=1 week
Added list price=\$61

Round Back chairs with both FR and vinyl together must be ordered as a Special.

SPECIAL SERVICES

Special Carton Marking

With specially marked information N/C









Shipping

Ships **assembled, FOB Green Bay, WI 54302, freight prepaid.** Freight class 125.

Specifications and prices are subject to change without prior notice.

Stack/Nesting

Versa® Standard

| MODEL | | Features | MODEL NUMBER | | | | | | | | | |
|---|--|---|--------------|-------------|--------------------------|--------------------------|--------------------------|--------------------------|--------------------------|--------------------------|--------------------------|--------------------------|
| | | | Basic Model | Frame Color | Wood Color | Uph. Color | Fire Code | Glide Option | Back Style | Wood Back Cut-outs | Arm Option | |
|  VRB |  VSB | Four-Leg Armless Chair • Seat is foam cushioned and upholstered • Back is wood • Round tubular steel frame • "Kick back" rear leg style enhances stability • Ganger welded to frame and finished to match frame | Ganging | 15NAGUW | <input type="checkbox"/> | <input type="checkbox"/> | <input type="checkbox"/> | <input type="checkbox"/> | <input type="checkbox"/> | <input type="checkbox"/> | <input type="checkbox"/> | |
| | | | Non-Ganging | 15NALUW | <input type="checkbox"/> | <input type="checkbox"/> | <input type="checkbox"/> | <input type="checkbox"/> | <input type="checkbox"/> | <input type="checkbox"/> | <input type="checkbox"/> | <input type="checkbox"/> |
| VRUW | | | | | | | | | | | | |
|  VRB |  VSB | Four-Leg Wallsaver Armless Chair • Seat is foam cushioned and upholstered • Back is wood • Round tubular steel frame • Ganger welded to frame and finished to match frame • Wallsaver rear legs touch base of wall preventing chair back from contacting wall surface | Ganging | 15NAGUWWS | <input type="checkbox"/> | <input type="checkbox"/> | <input type="checkbox"/> | <input type="checkbox"/> | S | <input type="checkbox"/> | <input type="checkbox"/> | |
| | | | Non-Ganging | 15NALUWWS | <input type="checkbox"/> | <input type="checkbox"/> | <input type="checkbox"/> | <input type="checkbox"/> | S | <input type="checkbox"/> | <input type="checkbox"/> | |
| VRUW | | | | | | | | | | | | |
|  VRB |  VSB | Four-Leg Arm Chair • Seat is foam cushioned and upholstered • Back is wood • Round tubular steel frame • "Kick back" rear leg style enhances stability • Molded nylon or chrome plated (non-ganging) arms • Ganger fastened to nylon armrest | Ganging | 15WAGUW | <input type="checkbox"/> | <input type="checkbox"/> | <input type="checkbox"/> | <input type="checkbox"/> | <input type="checkbox"/> | <input type="checkbox"/> | <input type="checkbox"/> | MPA |
| | | | Non-Ganging | 15WALUW | <input type="checkbox"/> | <input type="checkbox"/> | <input type="checkbox"/> | <input type="checkbox"/> | <input type="checkbox"/> | <input type="checkbox"/> | <input type="checkbox"/> | <input type="checkbox"/> |
| VRUW | | | | | | | | | | | | |
|  VRB |  VSB | Four-Leg Wallsaver Arm Chair • Seat is foam cushioned and upholstered • Back is wood • Round tubular steel frame • Molded nylon or chrome plated (non-ganging) arms • Ganger fastened to nylon armrest • Wallsaver rear legs touch base of wall preventing chair back from contacting wall surface | Ganging | 15WAGUWWS | <input type="checkbox"/> | <input type="checkbox"/> | <input type="checkbox"/> | <input type="checkbox"/> | S | <input type="checkbox"/> | <input type="checkbox"/> | MPA |
| | | | Non-Ganging | 15WALUWWS | <input type="checkbox"/> | <input type="checkbox"/> | <input type="checkbox"/> | <input type="checkbox"/> | S | <input type="checkbox"/> | <input type="checkbox"/> | <input type="checkbox"/> |
| VRUW | | | | | | | | | | | | |

A

B

C

D

E

F

G

H

I

HOW TO ORDER

Indicate the following information on order form:

- Quantity of each item.
- Model number, including options. See "How To Build a Model Number".
- Any special service required.

Note: • The indicates that a choice is required.

- The absence of the indicates that no choice is required.
- Alpha-numeric characters in place of indicate that no other alternatives are available.

HOW TO BUILD A MODEL NUMBER

- A** Select basic model.

- B** Select frame color.
Refer to the **Product Color Options** page in this price list.

- C** Select wood back color.
Refer to the **Product Color Options** page in this price list.

- D** Select upholstery grade/color.
Refer to ki.com/fabrics

- E** Select fire code.
NFR - Compliance to TB 117-2013
FR - Compliance to TB 133

- F** Select glide option.
F - Felt Glides
P - Plastic glides
S - Steel glides (standard)

- G** Select back style.

VRB - Round (original style)
VSB - Square (new style)

- H** Select wood back cut-out.

CO1 - Square (round back only)
CO2 - Ellipse (round back only)
CO3 - Starburst (round back only)
CO4 - Fan (square back only)
CO5 - Split (square back only)
CO6 - Perforated (square back only)
NC - No cut-out (both styles)

- I** Select arm option.

CHA - Chrome plated
MPA - Poly



| Approx. Packaged Weight | Delivered Pricing Fabric Grade 1 & C.O.M. | Delivered Pricing Fabric Grade 2 | Delivered Pricing Fabric Grade 3 | Delivered Pricing C.O.V. | Delivered Pricing Vinyl Group 2V | Delivered Pricing Pallas Fabric Group P0 | Delivered Pricing Pallas Fabric Group P1 | Delivered Pricing Pallas Fabric Group P2 | Delivered Pricing Pallas Fabric Group P3 | Delivered Pricing Pallas Fabric Group P4 |
|-------------------------|---|----------------------------------|----------------------------------|--------------------------|----------------------------------|--|--|--|--|--|
| 17.0# | \$ 549 | \$ 566 | \$ 567 | \$ 549 | \$ 567 | \$ 558 | \$ 570 | \$ 592 | \$ 608 | \$ 634 |
| 15.0# | 534 | 554 | 556 | 534 | 556 | 548 | 560 | 580 | 595 | 621 |

| | | | | | | | | | | |
|-------|--------|--------|--------|--------|--------|--------|--------|--------|--------|--------|
| 17.0# | \$ 587 | \$ 604 | \$ 606 | \$ 587 | \$ 606 | \$ 597 | \$ 608 | \$ 631 | \$ 648 | \$ 674 |
| 15.0# | 572 | 592 | 593 | 572 | 593 | 586 | 597 | 618 | 638 | 658 |

| | | | | | | | | | | |
|-------|--------|--------|--------|--------|--------|--------|--------|--------|--------|--------|
| 18.0# | \$ 572 | \$ 592 | \$ 593 | \$ 572 | \$ 593 | \$ 586 | \$ 597 | \$ 618 | \$ 634 | \$ 658 |
| 16.0# | 562 | 580 | 581 | 562 | 581 | 575 | 586 | 606 | 621 | 649 |

| | | | | | | | | | | |
|-------|--------|--------|--------|--------|--------|--------|--------|--------|--------|--------|
| 18.0# | \$ 613 | \$ 631 | \$ 632 | \$ 613 | \$ 632 | \$ 625 | \$ 638 | \$ 655 | \$ 674 | \$ 698 |
| 16.0# | 602 | 618 | 620 | 602 | 620 | 614 | 624 | 646 | 658 | 686 |

INFORMATION

Note:

There are 2 wood and upholstered back styles to choose from:
 Round Back = VRB
 Square Back = VSB

The original ROUND wood back style (RB) has the following wood cut-out options only:
 C01 = Square
 C02 = Ellipse
 C03 = Standard
 NC = No cut-out

The new SQUARE wood back style (SB) has the following wood cut-out options only:
 C04 = Fan
 C05 = Split
 C06 = Perforated
 NC = No cut-out

UPHOLSTERY INFORMATION

C.O.M. Upholstery

C.O.M. requirement 1 yard per chair of 54" wide nondirectional fabric. For complete information on ordering C.O.M., see "Ordering C.O.M., C.O.V. and C.O.L." section.

OPTIONS

California TB133 Fire Safety Code

For California Technical Bulletin 133 compliant models, add the following upcharge:

Model=Upholstered
 Added Lead Time=1 week
 Added List Price=\$54

Round Back chairs with both FR and vinyl together must be ordered as a Special.

SPECIAL SERVICES

Special Carton Marking

With specially marked information N/C



Shipping

Ships **assembled, FOB Green Bay, WI 54302, freight prepaid.** Freight class 125.

Specifications and prices are subject to change without prior notice.

Stack/Nesting

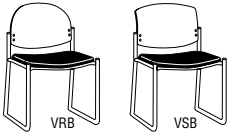
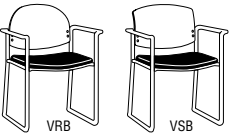
Versa® Standard

| MODEL | Features | MODEL NUMBER | | | | | | | | | |
|---|--|--------------|-------------|--------------------------|--------------------------|--------------------------|--------------------------|--------------------------|--------------------------|--------------------------|--------------------------|
| | | Basic Model | Frame Color | Wood Color | Uph. Color | Fire Code | Glide Option | Back Style | Wood Back Cut-outs | Arm Option | |
|  <p>VRB VSB</p> <p>VRUW</p> | <p>Sled Base Armless Chair</p> <ul style="list-style-type: none"> • Seat is foam cushioned and upholstered • Back is wood • Round tubular steel frame • Ganger version available. Ganger welded to frame and finished to match frame • NONSTACKING | Ganging | 15NASGUW | <input type="checkbox"/> | <input type="checkbox"/> | <input type="checkbox"/> | <input type="checkbox"/> | <input type="checkbox"/> | <input type="checkbox"/> | <input type="checkbox"/> | |
| | | Non-Ganging | 15NASUW | <input type="checkbox"/> | <input type="checkbox"/> | <input type="checkbox"/> | <input type="checkbox"/> | <input type="checkbox"/> | <input type="checkbox"/> | <input type="checkbox"/> | |
|  <p>VRB VSB</p> <p>VRUW</p> | <p>Sled Base Arm Chair</p> <ul style="list-style-type: none"> • Seat is foam cushioned and upholstered • Back is wood • Round tubular steel frame • Molded nylon or chrome plated (non-ganging) arms • Ganger fastened to nylon armrest • NONSTACKING | Ganging | 15WASGUW | <input type="checkbox"/> | <input type="checkbox"/> | <input type="checkbox"/> | <input type="checkbox"/> | <input type="checkbox"/> | <input type="checkbox"/> | MPA | |
| | | Non-Ganging | 15WASUW | <input type="checkbox"/> | <input type="checkbox"/> | <input type="checkbox"/> | <input type="checkbox"/> | <input type="checkbox"/> | <input type="checkbox"/> | <input type="checkbox"/> | <input type="checkbox"/> |
|  <p>HRDPT</p> | <p>Standard Versa® Transport Dolly, Non-Wallsaver</p> <ul style="list-style-type: none"> • Accommodates up to 10 stacking chairs • Easy maneuverability with 5" casters; two fixed, two swivel • Rugged weld tubular steel frame • Black powder-coated finish | | MVP.BL | | | | | | | | |

A B C D E F G H I

HOW TO ORDER

Indicate the following information on order form:

1. Quantity of each item.
2. Model number, including options. See "How To Build a Model Number".
3. Any special service required.

Note: • The indicates that a choice is required.

- The absence of the indicates that no choice is required.
- Alpha-numeric characters in place of indicate that no other alternatives are available.

HOW TO BUILD A MODEL NUMBER

- A** Select basic model.
- B** Select frame color.
Refer to the **Product Color Options** page in this price list.
- C** Select wood back color.
Refer to the **Product Color Options** page in this price list.
- D** Select upholstery grade/color.
Refer to ki.com/fabrics
- E** Select fire code.
NFR - Compliance to TB 117-2013
FR - Compliance to TB 133
- F** Select glide option.
NGL - No glides
NSG - Sled base non-skid glides; add \$23
- G** Select back style.

- VRB - Round (original style)
- VSB - Square (new style)

- H** Select wood back cut-out.
C01 - Square (round back only)
C02 - Ellipse (round back only)
C03 - Starburst (round back only)
C04 - Fan (square back only)
C05 - Split (square back only)
C06 - Perforated (square back only)
NC - No cut-out (both styles)

- I** Select arm option.
CHA - Chrome plated
MPA - Poly



| Approx. Packaged Weight | Delivered Pricing Unupholstered | Delivered Pricing Fabric Grade 1 & C.O.M. | Delivered Pricing Fabric Grade 2 | Delivered Pricing Fabric Grade 3 | Delivered Pricing C.O.V. | Delivered Pricing Vinyl Group 2V | Delivered Pricing Pallas Fabric Group P0 | Delivered Pricing Pallas Fabric Group P1 | Delivered Pricing Pallas Fabric Group P2 | Delivered Pricing Pallas Fabric Group P3 | Delivered Pricing Pallas Fabric Group P4 |
|-------------------------|---------------------------------|---|----------------------------------|----------------------------------|--------------------------|----------------------------------|--|--|--|--|--|
| 21.0# | N/A | \$ 722 | \$ 738 | \$ 740 | \$ 722 | \$ 740 | \$ 732 | \$ 744 | \$ 765 | \$ 781 | \$ 807 |
| 21.0# | N/A | 707 | 726 | 727 | 707 | 727 | 719 | 731 | 751 | 769 | 797 |
| 23.0# | N/A | \$ 748 | \$ 765 | \$ 766 | \$ 748 | \$ 766 | \$ 759 | \$ 770 | \$ 791 | \$ 807 | \$ 834 |
| 23.0# | N/A | 735 | 751 | 754 | 735 | 754 | 747 | 759 | 776 | 797 | 821 |
| 19.0# | \$ 471 | | | | | | | | | | |

INFORMATION

Note:

There are 2 wood and upholstered back styles to choose from:
 Round Back = VRB
 Square Back = VSB

The original ROUND wood back style (RB) has the following wood cut-out options only:
 C01 = Square
 C02 = Ellipse
 C03 = Standard
 NC = No cut-out

The new SQUARE wood back style (SB) has the following wood cut-out options only:
 C04 = Fan
 C05 = Split
 C06 = Perforated
 NC = No cut-out

UPHOLSTERY INFORMATION

C.O.M. Upholstery

C.O.M. requirement 1 yard per chair of 54" wide nondirectional fabric. For complete information on ordering C.O.M., see "Ordering C.O.M., C.O.V. and C.O.L." section.

OPTIONS

California TB133 Fire Safety Code

For California Technical Bulletin 133 compliant models, add the following upcharge:

Model=Upholstered
 Added Lead Time=1 week
 Added List Price=\$54

Round Back chairs with both FR and vinyl together must be ordered as a Special.

SPECIAL SERVICES

Special Carton Marking

With specially marked information N/C

Shipping

Ships **assembled, FOB Green Bay, WI 54302, freight prepaid.** Freight class 125.

Specifications and prices are subject to change without prior notice.

Stack/Nesting

Versa® Standard Cafe Stools

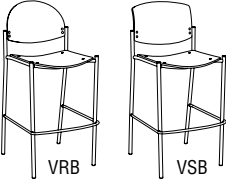
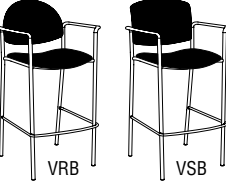
| Features | MODEL NUMBER | | | | | | | | | | Approx. Packaged Weight |
|--|---------------------|-------------|--------------------------|--|--|--------------------------|--------------------------|--|--|--|-------------------------|
| | Basic Model | Frame Color | Wood Color | Upholstery Color | Fire Code | Glide Option | Back Style | Wood Back Cut-outs | Arm Option | | |
|  <p>VRB VSB</p> <p>SVRUP SVRUW SVRWD</p> <p>Four-Leg Armless Cafe Stool</p> <ul style="list-style-type: none"> • Back and seat are foam cushioned/upholstered or wood • Round tubular steel frame • NONSTACKING | Upholstered | S96NAL | <input type="checkbox"/> | | <input type="checkbox"/> <input type="checkbox"/> <input type="checkbox"/> <input type="checkbox"/> <input type="checkbox"/> | <input type="checkbox"/> | <input type="checkbox"/> | <input type="checkbox"/> <input type="checkbox"/> <input type="checkbox"/> | | | 29.0# |
| | Uph Seat, Wood Back | S15NALUW | <input type="checkbox"/> | <input type="checkbox"/> <input type="checkbox"/> <input type="checkbox"/> | <input type="checkbox"/> <input type="checkbox"/> <input type="checkbox"/> <input type="checkbox"/> <input type="checkbox"/> | <input type="checkbox"/> | <input type="checkbox"/> | <input type="checkbox"/> <input type="checkbox"/> <input type="checkbox"/> | <input type="checkbox"/> <input type="checkbox"/> <input type="checkbox"/> | | 29.0# |
| | Wood | S15NALW | <input type="checkbox"/> | <input type="checkbox"/> <input type="checkbox"/> <input type="checkbox"/> | | | <input type="checkbox"/> | <input type="checkbox"/> <input type="checkbox"/> <input type="checkbox"/> | <input type="checkbox"/> <input type="checkbox"/> <input type="checkbox"/> | | 29.0# |
|  <p>VRB VSB</p> <p>SVRUP SVRUW SVRWD</p> <p>Four-Leg Cafe Stool with Arms</p> <ul style="list-style-type: none"> • Back and seat are foam cushioned/upholstered or wood • Round tubular steel frame • Molded nylon or chrome plated arms • NONSTACKING | Upholstered | S96WAL | <input type="checkbox"/> | | <input type="checkbox"/> <input type="checkbox"/> <input type="checkbox"/> <input type="checkbox"/> <input type="checkbox"/> | <input type="checkbox"/> | <input type="checkbox"/> | <input type="checkbox"/> <input type="checkbox"/> <input type="checkbox"/> | <input type="checkbox"/> <input type="checkbox"/> <input type="checkbox"/> | 30.0# | |
| | Uph Seat, Wood Back | S15WALUW | <input type="checkbox"/> | <input type="checkbox"/> <input type="checkbox"/> <input type="checkbox"/> | <input type="checkbox"/> <input type="checkbox"/> <input type="checkbox"/> <input type="checkbox"/> <input type="checkbox"/> | <input type="checkbox"/> | <input type="checkbox"/> | <input type="checkbox"/> <input type="checkbox"/> <input type="checkbox"/> | <input type="checkbox"/> <input type="checkbox"/> <input type="checkbox"/> | <input type="checkbox"/> <input type="checkbox"/> <input type="checkbox"/> | 30.0# |
| | Wood | S15WALW | <input type="checkbox"/> | <input type="checkbox"/> <input type="checkbox"/> <input type="checkbox"/> | | | <input type="checkbox"/> | <input type="checkbox"/> <input type="checkbox"/> <input type="checkbox"/> | <input type="checkbox"/> <input type="checkbox"/> <input type="checkbox"/> | <input type="checkbox"/> <input type="checkbox"/> <input type="checkbox"/> | 30.0# |
| | | | A | B | C | D | E | F | G | H | I |

HOW TO ORDER

Indicate the following information on order form:

- Quantity of each item.
- Model number, including options. See "How To Build a Model Number".
- Any special service required.

Note: • The indicates that a choice is required.

- The absence of the indicates that no choice is required.
- Alpha-numeric characters in place of indicate that no other alternatives are available.

HOW TO BUILD A MODEL NUMBER

A Select basic model.

B Select frame color.
Refer to the **Product Color Options** page in this price list.

C Select wood color.
Refer to the **Product Color Options** page in this price list.

D Select upholstery grade/color.
Refer to ki.com/fabrics

E Select fire code.
NFR - Compliance to TB 117-2013
FR - Compliance to TB 133

F Select glide option.
F - Felt Glides
P - Plastic glides
S - Steel glides (standard)

G Select back style.
VRB - Round (original style)
VSB - Square (new style)

H Select wood back cut-out.
C01 - Square (round back only)
C02 - Ellipse (round back only)
C03 - Starburst (round back only)
C04 - Fan (square back only)
C05 - Split (square back only)
C06 - Perforated (square back only)
NC - No cut-out (both styles)

I Select arm option.
CHA - Chrome plated
MPA - Poly



| Delivered Pricing Unupholstered | Delivered Pricing Fabric Grade 1 & C.O.M. | Delivered Pricing Fabric Grade 2 | Delivered Pricing Fabric Grade 3 | Delivered Pricing C.O.V. | Delivered Pricing Vinyl Group 2V | Delivered Pricing Pallas Fabric Group P0 | Delivered Pricing Pallas Fabric Group P1 | Delivered Pricing Pallas Fabric Group P2 | Delivered Pricing Pallas Fabric Group P3 | Delivered Pricing Pallas Fabric Group P4 |
|---------------------------------|---|----------------------------------|----------------------------------|--------------------------|----------------------------------|--|--|--|--|--|
| N/A | \$ 832 | \$ 866 | \$ 867 | \$ 832 | \$ 867 | \$ 864 | \$ 876 | \$ 913 | \$ 951 | \$ 990 |
| N/A | 881 | 900 | 901 | 881 | 901 | 892 | 904 | 922 | 943 | 966 |
| 987 | | | | | | | | | | |

| | | | | | | | | | | |
|------|--------|--------|--------|--------|--------|--------|--------|--------|--------|---------|
| N/A | \$ 858 | \$ 893 | \$ 895 | \$ 858 | \$ 895 | \$ 889 | \$ 901 | \$ 943 | \$ 977 | \$ 1020 |
| N/A | 909 | 925 | 927 | 909 | 927 | 920 | 931 | 951 | 966 | 992 |
| 1012 | | | | | | | | | | |

INFORMATION

Note:

There are 2 wood and upholstered back styles to choose from:
 Round Back = VRB
 Square Back = VSB

The original ROUND wood back style (RB) has the following wood cut-out options only:
 C01 = Square
 C02 = Ellipse
 C03 = Standard
 NC = No cut-out

The new SQUARE wood back style (SB) has the following wood cut-out options only:
 C04 = Fan
 C05 = Split
 C06 = Perforated
 NC = No cut-out

UPHOLSTERY INFORMATION

C.O.M. Upholstery

C.O.M. requirement 1 yard per chair of 54" wide nondirectional fabric. For complete information on ordering C.O.M., see "Ordering C.O.M., C.O.V. and C.O.L." section.

OPTIONS

California TB133 Fire Safety Code

For California Technical Bulletin 133 compliant models, add the following upcharge:

Model=Upholstered
 Added Lead Time=1 week
 Added list price=\$59

Round Back chairs with both FR and vinyl together must be ordered as a Special.

SPECIAL SERVICES

Special Carton Marking

With specially marked information N/C

Shipping

Ships **assembled, FOB Green Bay, WI 54302, freight prepaid.** Freight class 125.

Specifications and prices are subject to change without prior notice.

Stack/Nesting

Versa® XL General Information



Four-Leg Arm Chair
Ganging (VXLAG)



Four-Leg Arm Chair
Non-ganging (VXLAN)

Four-Leg Armless Chair
Non-ganging (VXLN)

| Features | | | |
|-----------------------|-------------------|-------------------|-------------------|
| Stackable | • | • | • |
| Ganging | • | | |
| Warranted to 500 lbs. | • | • | • |
| General Dimensions | | | |
| Seat width | 30" | 30" | 30" |
| Seat depth | 20" | 20" | 20" |
| Seat height | 20" | 20" | 20" |
| Overall Dimensions | | | |
| Width | 35-3/8" | 35-3/8" | 32" |
| Depth | 25-1/4" | 25-1/4" | 25-1/4" |
| Height | 37" | 37" | 37" |
| Ganging on center | 24-3/8" | | |
| Arms to floor | 26-1/4" | 26-1/4" | |
| Stacking on Floor | | | |
| Width | 35-3/4" | 35-3/4" | 32" |
| Depth | 32-1/2" | 32-1/2" | 32-1/2" |
| Quantity/height | 4 Chairs/49" High | 4 Chairs/49" High | 4 Chairs/49" High |



Ganging



Kick Back Leg

SPECIFICATIONS

Frame

Legs of 1" o.d. x 16-gauge high-strength tubular steel. "Kick back" rear legs increase structural integrity and adds to stability. The rear legs on the wallsaver frame have a greater "kick back" angle so the legs touch the wall before the backrest. Side members and cross tube members will be of 1" o.d. x 14-gauge tubular steel. 11-gauge gussets will be located on the front legs to increase strength and rigidity. Standard front and rear legs are joined to side members by brazing; all other joints are manually welded. Wall-saver rear legs are manually welded to the side members; front legs are brazed. Formed 11-gauge steel brackets welded to the rear legs are used to support the backrest.

Frame Finishes

30-sheen epoxy powder coating is electrostatically applied. The dry coating is then fused and cured in a baking oven to form a smooth, continuous film. Finish is chemical

resistant, hard, touch and mar resistant. Bright chrome surfaces are duplex nickel chrome plated in a twenty-two step process.

Floor Glides

Available in chrome-plated steel or monochromatic plastic for standard four-leg. (Black plastic on chrome and hammertone frames.) Wallsaver chairs are only available with chrome-plated steel glides.

Armrests

Molded nylon pressed into the front and rear leg tubes. Armrests are monochromatic with frame. On chrome and hammertone frames, they will be black.

Tube End Caps (No-Arm Chair)

Molded plastic. The end cap will match the frame color. Chrome and hammertone frames have black end caps.

Upholstered Seat

Seat is a flat, 5-ply 15/32" thick, radiate pine plywood (AraucoPly or similar) fastened to the frame with four screws through T-nuts embedded in the seat. A 2-1/2" thick urethane foam cushion is glued to seatboard.

Upholstered Backrest-Round or Square (option)

Two-piece construction. The front is constructed of a flat, 4-ply, 1/2" thick #3 gum veneer wood back fastened to frame with eight screws through T-nuts in wood backrest. A 2" urethane foam cushion applied to backrest. The back is constructed of 1/4" thick padding, 3-ply, 3/16" thick #3 gum veneer. Attached with eight steel fasteners and the backrest bracket.



| | Four-Leg Wallsaver Arm Chair Ganging (VXLAGWS) | Four-Leg Wallsaver Arm Chair Non-ganging (VXLNWS) | Four-Leg Wallsaver Armless Chair Non-ganging (VXLNWS) |
|---------------------------|---|--|--|
| Features | | | |
| Stackable | • | • | • |
| Ganging | • | | |
| Warranted to 500 lbs. | • | • | • |
| General Dimensions | | | |
| Seat width | 30" | 30" | 30" |
| Seat depth | 20" | 20" | 20" |
| Seat height | 20" | 20" | 20" |
| Overall Dimensions | | | |
| Width | 35-3/8" | 35-3/8" | 32" |
| Depth | 28-3/4" | 28-3/4" | 28-3/4" |
| Height | 37" | 37" | 37" |
| Ganging on center | 24-3/8" | | |
| Arms to floor | 26-1/4" | 26-1/4" | |
| Stacking on Floor | | | |
| Width | 35-3/4" | 35-3/4" | 32" |
| Depth | 35-3/4" | 35-3/4" | 35-3/4" |
| Quantity/height | 4 Chairs/49" High | 4 Chairs/49" High | 4 Chairs/49" High |

INFORMATION

C.O.M. Testing and Production Requirements

Not all materials are suitable for upholstering this product. A 2 yd. x 54" sample must be submitted and approved prior to acceptance of an order. If the fabric is directional in pattern or weave, the direction must be indicated on the submitted sample, and additional yardage may be requested.

Test samples must be sent to:

KI
Attn: C.O.M. Specialist
1687 Westminster Drive - Gate 3
Green Bay, WI 54302

Fabric Disclaimer

Fabric will be applied as swatched by the fabric manufacturer. Fabric that is required to be applied differently than is swatched will need a Special Cost Request written specifying the direction the fabric is to be applied. The posted standard lead time will apply to the Special Cost Request.

INFORMATION

Warranty

Refer to KI Terms & Conditions document or visit ki.com

Stack/Nesting

Versa® XL Color Options

Frame Color

| | |
|--------------|----|
| Antique Vein | AV |
| Black | BL |
| Blue Grey | GR |
| Chrome | CH |
| Cool Grey | CG |
| Flannel | FN |
| Light Tone | LG |
| Mardi Gras | MG |
| Misty Brown | MY |
| Nemo | NE |
| Nickel Vein | NK |
| Nordic | ND |
| Purple Haze | PH |
| Rubber Ducky | RK |
| Sand | SA |
| Surf's Up | SP |
| Ultra Blue | UB |
| Warm Grey | WG |
| Wet Sand | WS |
| Zesty Lime | ZL |

Armrests or end caps will match frame color unless frame is chrome or hammertone, then they will be black.

Finish Cards

View color swatches for items listed within this document.

Paints

Wood/Veneer

Molded Edges

Hard Plastics

Plastics/Poly

Laminates

Edge Styles

Glass



Stack/Nesting

Versa® XL

| | MODEL | Features | MODEL NUMBER | | | | | | Approx. Packaged Weight |
|----------|---|-------------|--------------|---|---|--------------------------|--|--------------------------|-------------------------|
| | | | Basic Model | Upholstery Color | Fire Code | Frame Color | Back Style | Glide Option | |
| VXLU | Four-Leg Armless Chair <ul style="list-style-type: none"> • Generously proportioned seat and back have thick foam cushioning and are upholstered • Back is fully upholstered • Round tubular steel frame • "Kick back" rear leg style enhances stability • Powder-coated or chrome plated frames | Non-Ganging | VXLN | <input type="checkbox"/> <input type="checkbox"/> <input type="checkbox"/> <input type="checkbox"/> | <input type="checkbox"/> <input type="checkbox"/> | <input type="checkbox"/> | <input type="checkbox"/> <input type="checkbox"/> <input type="checkbox"/> | <input type="checkbox"/> | 39.0# |
| VXLU | Four-Leg Wallsaver Armless Chair <ul style="list-style-type: none"> • Generously proportioned seat and back have thick foam cushioning and are upholstered • Back is fully upholstered • Round tubular steel frame • "Kick back" rear leg style enhances stability • Powder-coated or chrome plated frames • Wallsaver rear legs touch base of wall preventing chair back from contacting wall | Non-Ganging | VXLNWS | <input type="checkbox"/> <input type="checkbox"/> <input type="checkbox"/> <input type="checkbox"/> | <input type="checkbox"/> <input type="checkbox"/> | <input type="checkbox"/> | <input type="checkbox"/> <input type="checkbox"/> <input type="checkbox"/> | S | 39.0# |
| | | | A | B | C | D | E | F | |

HOW TO ORDER

Indicate the following information on order form:

1. Quantity of each item.
2. Model number, including options. See "How To Build a Model Number".
3. Any special service required.

Note: • The indicates that a choice is required.

- The absence of the indicates that no choice is required.
- Alpha-numeric characters in place of indicate that no other alternatives are available.

HOW TO BUILD A MODEL NUMBER

- A** Select basic model.
- B** Select upholstery grade/color.
Refer to ki.com/fabrics
- C** Select fire code.
NFR - Compliance to TB 117-2013
FR - Compliance to TB 133
- D** Select frame color.
Refer to the **Product Color Options** page in this price list.
Armrests or end caps will match frame color, unless frame is chrome or hammertone (then black).
- E** Select back style.
VRB - Round (original style)
VSB - Square (new style)
- F** Select glide option.
P - Plastic glides
S - Steel glides (standard)



| Delivered Pricing Fabric Grade 1 & C.O.M. | Delivered Pricing Fabric Grade 2 | Delivered Pricing Fabric Grade 3 | Delivered Pricing C.O.V. | Delivered Pricing Vinyl Group 2V | Delivered Pricing Pallas Fabric Group P0 | Delivered Pricing Pallas Fabric Group P1 | Delivered Pricing Pallas Fabric Group P2 | Delivered Pricing Pallas Fabric Group P3 | Delivered Pricing Pallas Fabric Group P4 |
|---|----------------------------------|----------------------------------|--------------------------|----------------------------------|--|--|--|--|--|
| \$ 718 | \$ 754 | \$ 768 | \$ 718 | \$ 768 | \$ 853 | \$ 933 | \$ 994 | \$ 1051 | \$ 1096 |
| \$ 808 | \$ 843 | \$ 858 | \$ 808 | \$ 858 | \$ 944 | \$ 1023 | \$ 1085 | \$ 1142 | \$ 1186 |

UPHOLSTERY INFORMATION

C.O.M. Upholstery

C.O.M. requirement for 10 chairs or less is 2 yards per chair of 54" wide nondirectional fabric. For orders of 11 or more chairs and for complete information on ordering C.O.M., see "Ordering C.O.M., C.O.V. and C.O.L." section.

INFORMATION

Note:

There are 2 back styles to choose from:
Round Back = VRB (original style)
Square Back = VSB (new style)

OPTIONS

California TB133 Fire Safety Code
For California Technical Bulletin 133 compliant models, add the following upcharge:

Model=XL
Added Lead Time=1 week
Added List Price=\$152

Round Back chairs with both FR and vinyl together must be ordered as a Special.

SPECIAL SERVICES

Special Carton Marking

With specially marked information N/C

Shipping

Ships **assembled, FOB Green Bay, WI 54302, freight prepaid.** Freight class 125.

Specifications and prices are subject to change without prior notice.

Stack/Nesting

Versa® XL

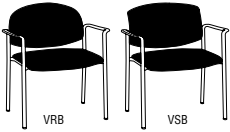
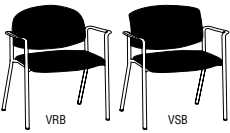
| MODEL | | Features | MODEL NUMBER | | | | | | Approx. Packaged Weight |
|---|---|-------------|--------------|--|---|---|--|--------------------------|-------------------------|
| | | | Basic Model | Upholstery Color | Fire Code | Frame Color | Back Style | Glide Option | |
|  <p>VRB VSB</p> <p>VXLU</p> | Four-Leg Arm Chair <ul style="list-style-type: none"> • Generously proportioned seat and back have thick foam cushioning and are upholstered • Back is fully upholstered • Round tubular steel frame • "Kick back" rear leg style enhances stability • Molded nylon arms • Ganger fastened to armrest and chrome finished • Powder-coated or chrome plated frames | Ganging | VXLAG | <input type="checkbox"/> <input type="checkbox"/> <input type="checkbox"/> <input type="checkbox"/> <input type="checkbox"/> | <input type="checkbox"/> <input type="checkbox"/> | <input type="checkbox"/> <input type="checkbox"/> | <input type="checkbox"/> <input type="checkbox"/> <input type="checkbox"/> | <input type="checkbox"/> | 42.0# |
| | | Non-Ganging | VXLAN | <input type="checkbox"/> <input type="checkbox"/> <input type="checkbox"/> <input type="checkbox"/> <input type="checkbox"/> | <input type="checkbox"/> <input type="checkbox"/> | <input type="checkbox"/> <input type="checkbox"/> | <input type="checkbox"/> <input type="checkbox"/> <input type="checkbox"/> | <input type="checkbox"/> | 42.0# |
|  <p>VRB VSB</p> <p>VXLU</p> | Four-Leg Wallsaver Arm Chair <ul style="list-style-type: none"> • Generously proportioned seat and back have thick foam cushioning and are upholstered • Back is fully upholstered • Round tubular steel frame • "Kick back" rear leg style enhances stability • Powder-coated or chrome plated frames • Wallsaver rear legs touch base of wall preventing chair back from contacting wall | Ganging | VXLAGWS | <input type="checkbox"/> <input type="checkbox"/> <input type="checkbox"/> <input type="checkbox"/> <input type="checkbox"/> | <input type="checkbox"/> <input type="checkbox"/> | <input type="checkbox"/> <input type="checkbox"/> | <input type="checkbox"/> <input type="checkbox"/> <input type="checkbox"/> | S | 42.0# |
| | | Non-Ganging | VXLANWS | <input type="checkbox"/> <input type="checkbox"/> <input type="checkbox"/> <input type="checkbox"/> <input type="checkbox"/> | <input type="checkbox"/> <input type="checkbox"/> | <input type="checkbox"/> <input type="checkbox"/> | <input type="checkbox"/> <input type="checkbox"/> <input type="checkbox"/> | S | 42.0# |
| | | | A | B | C | D | E | F | |

HOW TO ORDER

Indicate the following information on order form:

1. Quantity of each item.
2. Model number, including options. See "How To Build a Model Number".
3. Any special service required.

Note: • The indicates that a choice is required.

- The absence of the indicates that no choice is required.
- Alpha-numeric characters in place of indicate that no other alternatives are available.

HOW TO BUILD A MODEL NUMBER

- A** Select basic model.
- B** Select upholstery grade/color. Refer to ki.com/fabrics
- C** Select fire code.

| | |
|------------|-----------------------------|
| NFR | - Compliance to TB 117-2013 |
| FR | - Compliance to TB 133 |
- D** Select frame color. Refer to the **Product Color Options** page in this price list. Armrests or end caps will match frame color, unless frame is chrome or hammertone (then black).
- E** Select back style.

| | |
|------------|--------------------------|
| VRB | - Round (original style) |
| VSB | - Square (new style) |
- F** Select glide option.

| | |
|----------|---------------------------|
| P | - Plastic glides |
| S | - Steel glides (standard) |



| Delivered Pricing C.O.M. | Delivered Pricing Fabric Grade 1 | Delivered Pricing Fabric Grade 2 | Delivered Pricing Fabric Grade 3 | Delivered Pricing C.O.V. | Delivered Pricing Vinyl Group 2V | Delivered Pricing Pallas Fabric Group P0 | Delivered Pricing Pallas Fabric Group P1 | Delivered Pricing Pallas Fabric Group P2 | Delivered Pricing Pallas Fabric Group P3 | Delivered Pricing Pallas Fabric Group P4 |
|--------------------------|----------------------------------|----------------------------------|----------------------------------|--------------------------|----------------------------------|--|--|--|--|--|
| \$ 779 | \$ 779 | \$ 814 | \$ 829 | \$ 779 | \$ 829 | \$ 918 | \$ 997 | \$ 1057 | \$ 1113 | \$ 1156 |
| 762 | 762 | 798 | 809 | 762 | 809 | 895 | 976 | 1035 | 1094 | 1139 |

| | | | | | | | | | | |
|--------|--------|--------|--------|--------|--------|---------|---------|---------|---------|---------|
| \$ 870 | \$ 870 | \$ 906 | \$ 919 | \$ 870 | \$ 919 | \$ 1008 | \$ 1088 | \$ 1146 | \$ 1204 | \$ 1248 |
| 852 | 852 | 887 | 900 | 852 | 900 | 986 | 1066 | 1125 | 1182 | 1228 |

UPHOLSTERY INFORMATION

C.O.M. Upholstery

C.O.M. requirement for 10 chairs or less is 2 yards per chair of 54" wide nondirectional fabric. For orders of 11 or more chairs and for complete information on ordering C.O.M., see "Ordering C.O.M., C.O.V. and C.O.L." section.

INFORMATION

Note:

There are 2 back styles to choose from:
 Round Back = VRB (original style)
 Square Back = VSB (new style)

OPTIONS

California TB133 Fire Safety Code

For California Technical Bulletin 133 compliant models, add the following upcharge:

Model=XL
 Added Lead Time=1 week
 Added List Price=\$152

Round Back chairs with both FR and vinyl together must be ordered as a Special.

SPECIAL SERVICES

Special Carton Marking

With specially marked information N/C

Shipping

Ships **assembled, FOB Green Bay, WI 54302, freight prepaid.** Freight class 125.

Specifications and prices are subject to change without prior notice.

Stack Seating

Xylon® General Information



**Metal Frame Chair
(PXM)**

Features

| | |
|-------------------|---|
| Stackable | • |
| Articulating back | • |

General Dimensions

| | |
|-------------|---------|
| Seat width | 16-7/8" |
| Seat depth | 17-1/2" |
| Seat height | 18-5/8" |
| Back width | 16-1/4" |
| Back height | 15-1/2" |

Overall Dimensions

| | |
|--------|---------|
| Width | 16-7/8" |
| Depth | 20-7/8" |
| Height | 33-1/8" |

Stacking on Dolly

| | |
|-----------------|-------------------|
| Quantity/height | 8 Chairs/54" High |
| Floor space | 24" x 35" |

Stacking on Floor

| | |
|-----------------|-------------------|
| Quantity/height | 8 Chairs/50" High |
| Floor space | 24" x 35" |

SPECIFICATIONS

Seat and Backrest

Plywood is made of beechwood and gum veneer. Backrest thickness is .4". Seat thickness is .5". Seat and backrest surfaces are finished with stain and/or two applications of clear coat for a very durable finish. Seat/back support is nickel-plated aluminum. The back tilt is 15° (3-3/4").

Spring Action Backrests

Metal plate fixed under the seat containing a spring mechanism which allows movement of the backrest.

Metal Frame Chair

Frames are 7/8" o.d., 16-gauge seam-welded tubular steel.

Metal Frame Finishes

Baked-on, electrostatically-applied epoxy powder coating, or bright nickel-chrome plating.

Metal Frame Glides

Polypropylene.

Transport Dolly

Round tubular steel frame. Four 3" swivel wheels. Back powder-coated finish. 4-3/4" high from floor, empty.

Design

Designed by Giancarlo Piretti and manufactured in the USA by Krueger International, Inc. under license from Pro-Cord S.p.A.



INFORMATION

Warranty
Refer to KI Terms & Conditions document
or visit ki.com

Stack/Nesting

Xylon® Color Options

Frame Color - Steel

| | |
|--------------|----|
| Antique Vein | AV |
| Black | BL |
| Blue Grey | GR |
| Chrome | CH |
| Cool Grey | CG |
| Mardi Gras | MG |
| Misty Brown | MY |
| Nemo | NE |
| Nickel Vein | NK |
| Purple Haze | PH |
| Rubber Ducky | RK |
| Sand | SA |
| Surf's Up | SP |
| Ultra Blue | UB |
| Warm Grey | WG |
| Zesty Lime | ZL |

Wood Seat/Back Finish

| | |
|---------------------------|-----|
| Cherry Storm on Beech | BCX |
| Cinnamon on Beech | BCN |
| Cocoa on Beech | BCA |
| Eclipse Black on Beech | BEB |
| Florence Walnut on Beech | BFC |
| Monticello Maple on Beech | BMT |
| Natural on Beech | BNA |
| River Cherry on Beech | BRY |

Xylon wood chairs are beechwood. All colors match the corresponding laminate color.

All stain colors are acceptable for CA 133.

Finish Cards

View color swatches for items listed within this document.

[Paints](#)

[Wood/Veneer](#)

[Molded Edges](#)

[Hard Plastics](#)

[Plastics/Poly](#)

[Laminates](#)

[Edge Styles](#)

[Glass](#)



Stack Seating

Xylon®

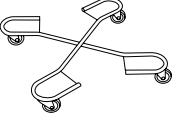
| | MODEL | Features | MODEL NUMBER | | | | Approx. Packaged Weight |
|---|--|----------|--------------|---|--|--|-------------------------|
| | | | Basic Model | Frame Color | Seat & Back Color | Glide Option | |
|  PX | Four-Leg Metal Frame Chair • Spring mechanism allows movement of backrest • Seat and backrest available in wood stains • Round tubular steel frame | Stacking | PXM | <input type="checkbox"/> <input type="checkbox"/> | <input type="checkbox"/> <input type="checkbox"/> <input type="checkbox"/> | <input type="checkbox"/> <input type="checkbox"/> <input type="checkbox"/> | 16.0# |
| | | | | | | | |
| | | | | | | | |
| | | | | | | | |
|  HRDPT | X-Frame Stack Chair Dolly • Four 3" swivel wheels • Black enamel finish only | | FD.BL | | | | 12.0# |
| | | | | | | | |
| | | | | | | | |
| | | | | | | | |
| | | | A | B | C | D | |

HOW TO ORDER

Indicate the following information on order form:

- Quantity of each item.
- Model number, including options. See "How To Build a Model Number".
- Any special service required.

Note: • The indicates that a choice is required.

- The absence of the indicates that no choice is required.
- Alpha-numeric characters in place of indicate that no other alternatives are available.

HOW TO BUILD A MODEL NUMBER

- A** Select basic model.
- B** Select frame color.
Refer to the **Product Color Options** page in this price list.
- C** Select seat/back color.
Refer to the **Product Color Options** page in this price list.
- D** Select glide option.
- | | |
|------------|------------------|
| PGL | - Plastic glides |
| SGL | - Steel glides |
- Steel glides not available on wood legs.



Delivered
Pricing

\$ 616

\$ 224

OPTIONS

Lacquered and Aniline Dyes

Contact KI for pricing.

SPECIAL SERVICES

Special Carton Marking

With specially marked information N/C

Shipping

Ships **assembled, FOB Green Bay, WI 54302, freight prepaid.** Freight class 125.

Specifications and prices are subject to change without prior notice.

Guest Seating

Bantam™ General Information



**Bantam™
(Traditional)**

General Dimensions

| | |
|------------------------|---------|
| Seat width | 19" |
| Seat depth | 18-1/2" |
| Seat height | 18-1/2" |
| Arm height (mid point) | 25" |

Overall Dimensions

| | |
|--------|---------|
| Width | 22-3/4" |
| Depth | 24-1/2" |
| Height | 32" |

UPHOLSTERY INFORMATION

C.O.M. Fabric

For C.O.M. fabric sent to KI-High Point on multiple rolls, add an additional yard of fabric per roll to the yardage requirements. Multiple rolls have shorter pieces of fabric on them and do not allow nesting and stacking of the fabric to achieve the best yield as is done with one large roll. This results in yardage shortages and requests for additional fabric from the client, which can hold up the order. For each roll that is sent, one yard needs to be added and needs to be added to one of the rolls, not separately.

Fabric Disclaimer

Fabric will be applied as swatched by the fabric manufacturer. Fabric that is required to be applied differently than is swatched will need a Special Cost Request written specifying the direction the fabric is to be applied. The posted standard lead time will apply to the Special Cost Request.

FINISH INFORMATION

SPECIAL FINISH MATCHES

KI can match special finish requests at an upcharge of \$73 List per item, up to 12 or a maximum charge of \$881 List per order per color. Special finish requests must be sent to your KI customer service representative.

Upon receipt from KI, the finishing department will prepare a "strike-off" which will be sent to the customer for approval.

The approval form accompanying the strike-off should be faxed to your KI customer service representative. Upon receipt of the signed approval form, KI will proceed with the order. Disapproved samples may be sent back to KI directly with an explanation of disapproval. A Special Finish Number (SFN) will be assigned to this finish sample for future reference or reorders



INFORMATION

Warranty
Refer to KI Terms & Conditions document
or visit ki.com

Guest Seating

Bantam™ Color Options

Wood Finish - Core

| | |
|---------------------------|-----|
| Cherry Storm on Beech | BCX |
| Cinnamon on Beech | BCN |
| Cocoa on Beech | BCA |
| Eclipse Black on Beech | BEB |
| Florence Walnut on Beech | BFC |
| Kensington Maple on Maple | MMA |
| Monticello Maple on Beech | BMT |
| Natural on Beech | BNA |
| River Cherry on Beech | BRY |

Kensington Maple requires an upcharge.

Finish Cards

View color swatches for items listed within this document.

Paints

Plastics/Poly

Wood/Veneer

Laminates

Molded Edges

Edge Styles

Hard Plastics

Glass



Guest Seating

Bantam™ Color Options

Guest Seating

Bantam™

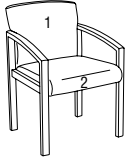

BANT

| MODEL | Features | COM | MODEL NUMBER | | | | | Approx. Packaged Weight |
|--|--------------|--------|--------------|---|---|--|--|-------------------------|
| | | | Basic Model | Non-Contrast or Fabric Contrast 1 | Fabric Contrast 2 | Wood Finish | Fire Code | |
| Arm Chair • 1 = Back (Fabric Contrast 1) C.O.M. = 1 yd • 2 = Seat (Fabric Contrast 2) C.O.M. = 1 yd | Non-contrast | 1.5 yd | 1301/NC | <input type="checkbox"/> <input type="checkbox"/> <input type="checkbox"/> <input type="checkbox"/> | | <input type="checkbox"/> <input type="checkbox"/> <input type="checkbox"/> | <input type="checkbox"/> <input type="checkbox"/> <input type="checkbox"/> | 50.0# |
| | Contrast | | 1301/FC | <input type="checkbox"/> <input type="checkbox"/> <input type="checkbox"/> <input type="checkbox"/> | <input type="checkbox"/> <input type="checkbox"/> <input type="checkbox"/> <input type="checkbox"/> | <input type="checkbox"/> <input type="checkbox"/> <input type="checkbox"/> | <input type="checkbox"/> <input type="checkbox"/> <input type="checkbox"/> | 50.0# |
| | | | | | | | | |
| | | | | | | | | |
| | | | | | | | | |

A **B** **C** **D** **E**

HOW TO ORDER

Indicate the following information on order form:

- Quantity of each item.
- Model number, including options. See "How To Build a Model Number".
- Any special service required.

Note: • The indicates that a choice is required.
• The absence of the indicates that no choice is required.
• Alpha-numeric characters in place of indicate that no other alternatives are available.

HOW TO BUILD A MODEL NUMBER

- A** Select basic model.
- B** Select non-contrast or fabric contrast 1. Refer to ki.com/fabrics
- C** Select non-contrast or fabric contrast 2. Refer to ki.com/fabrics
- D** Select wood finish color. Refer to the **Product Color Options** page in this price list.
- E** Select fire code.
 - NFR** - Compliance to TB 117-2013
 - FR** - Compliance to TB 133
 See pricing column for TB133 upcharge.



| Grade C.O.M. | Grade C | Grade D | Grade E & C.O.L. | Grade F | Grade G | Grade H | Grade I | Grade J | Grade K | Grade L Leather | Grade M Leather | TB133 add to list price |
|-----------------|------------|------------|------------------------|------------|------------|------------|------------|------------|------------|--------------------|--------------------|-------------------------------|
| \$ 1082 | \$ 1096 | \$ 1116 | \$ 1147 | \$ 1168 | \$ 1205 | \$ 1244 | \$ 1320 | \$ 1425 | \$ 1548 | \$ 1672 | \$ 1919 | \$ 212 |
| 1144 | 1156 | 1178 | 1207 | 1229 | 1267 | 1302 | 1379 | 1485 | 1611 | 1733 | 1984 | 212 |

KENSINGTON MAPLE UPCHARGE

Kensington Maple requires extended leadtimes.

| | |
|---------|------|
| Model | |
| 1301/NC | \$40 |
| 1301/FC | \$40 |

UPHOLSTERY INFORMATION

C.O.M. Requirements

C.O.M. yardage requirements listed above are based on plain goods 54" wide. If less than 54" wide or fabrics requiring matching (stripes, plaids, prints, large patterns), additional yardage will be needed. Consult C.O.M. matrix for additional yardage needed. For C.O.M. fabric sent to KI-High Point on multiple rolls, add an additional yard of fabric per roll to the yardage requirements.

C.O.L. Requirements

Figure 18 sq. ft. of leather (C.O.L.) for each yard shown (i.e., 4.75 x 18 = 85.5 sq. ft).

Contrasting Upholstery

When contrasting fabric is chosen, price at highest in-grade.

California TB133 Fire Safety Code

The above seating products can be manufactured using the appropriate flame-retardant materials and fabric selections for

compliance to California Technical Bulletin 133. Please contact KI customer service for fabric compliance. Not available with moisture barrier.

Construction

Frame of kiln-dried hardwood. Cushioning of high-density polyurethane foam and Dacron fiber.

SPECIAL SERVICES

Special Carton Marking

With specially marked information N/C

Shipping

Ships **assembled, FOB High Point, NC 27263, freight prepaid.** Freight class 175

Specifications and prices are subject to change without prior notice.

Guest Seating

Itoki™ General Information



DP Chair

General Dimensions

| | |
|-------------|-----------------|
| Seat width | 17-1/4" |
| Seat depth | 16-1/4" |
| Seat height | 17-3/4" |
| Arm width | 3-1/2" |
| Arm height | 27" (mid point) |

Overall Dimensions

| | |
|--------|---------|
| Width | 25-1/2" |
| Depth | 21-1/4" |
| Height | 32-1/2" |

UPHOLSTERY INFORMATION

Upholstery Finish

Some fabrics and leathers may show slight wrinkling in corners, around the seat, arms, or back which is normal. With use, comfort wrinkles may occur in seats and backs and give the upholstery a loose appearance.

WOOD INFORMATION

Wood Finish

Due to wood being a natural material, slight variations can occur in texture, color, grain configurations, and finish acceptance.

Therefore wood components may vary in tone or character from piece to piece and no guarantee of exact matches can be made.

Plywood Edge Color

The plies on the edge of wood backed shells will vary in color from the surface of the wood shell. The plies of the plywood shell edge will be visible and may create a wood contrast.



INFORMATION

Warranty

Refer to KI Terms & Conditions document
or visit ki.com

Guest Chairs

Itoki DP Chair Color Options

Base Finish Color

Chrome CH

Wood Finish

Natural on Walnut WNT

Upholstery Color

Black BLK

Red RED

Finish Cards

View color swatches for items listed within this document.

Paints

Plastics/Poly

Wood/Veneer

Laminates

Molded Edges

Edge Styles

Hard Plastics

Glass





Guest Chairs

Itoki DP Chair Color Options

Guest Seating

Itoki DP™ Chair

| | MODEL | Features | MODEL NUMBER | | | | Approx. Packaged Weight |
|---|---|--------------|--------------|--------------------------|--------------------------|--------------------------|-------------------------|
| | | | Basic Model | Base Finish | Wood Finish | Upholstery Color | |
|  <p>IDPC</p> | Chair with Upholstered Seat and Back • Natural on walnut shell • Chrome base | Non-contrast | IDP/SB | <input type="checkbox"/> | <input type="checkbox"/> | <input type="checkbox"/> | 30.0# |
| | | | | | | | |
| | | | | | | | |
| | | | | | | | |
|  <p>IDPC</p> | Chair with Upholstered Seat Only • Natural on walnut shell • Chrome base | Non-contrast | IDP/SO | <input type="checkbox"/> | <input type="checkbox"/> | <input type="checkbox"/> | 30.0# |
| | | | | | | | |
| | | | | | | | |
| | | | | | | | |

A **B** **C** **D**

HOW TO ORDER

Indicate the following information on order form:

- Quantity of each item.
- Model number, including options. See "How To Build a Model Number".
- Any special service required.

Note: • The indicates that a choice is required.

- The absence of the indicates that no choice is required.
- Alpha-numeric characters in place of indicate that no other alternatives are available.

HOW TO BUILD A MODEL NUMBER

- A** Select basic model.
- B** Select base finish.
Refer to the **Product Color Options** page in this price list.
- C** Select wood finish.
Refer to the **Product Color Options** page in this price list.
- D** Select upholstery color.
Refer to ki.com/fabrics



Guest Seating

Itoki DP™ Chair

Delivered
Pricing
\$ 2277

\$ 2175

SPECIAL SERVICES

Special Carton Marking

With specially marked information N/C

Shipping

Ships **assembled, FOB Grand Rapids, Michigan 49512, freight prepaid.** Freight class 125.

Specifications and prices are subject to change without prior notice.

Guest Seating

Jubi General Information



**Guest Chair
(JUBU)**

Features

| | |
|----------------------|---|
| Pivoting glides | • |
| Fiberglass | • |
| Upholstered seat pad | • |

Dimensions

| | |
|----------------|-------|
| Seat depth | 15" |
| Seat height | 18" |
| Overall width | 25" |
| Overall depth | 22" |
| Overall height | 32.5" |



INFORMATION

Warranty

Refer to KI Terms & Conditions document
or visit ki.com

Guest Chairs

Jubi™ Color Options

Fiberglass Shell Color

White JUWH

Frame Color

| | |
|---------------------------|----|
| Antique Vein | AV |
| Black | BL |
| Blue Grey | GR |
| Bronze Metallic | ZM |
| Cayenne | CY |
| Champagne Metallic | CM |
| Chocolate | CT |
| Chrome | CH |
| Cottonwood | CO |
| Espresso Metallic | EX |
| Flannel | FN |
| Grass Green | GN |
| Light Tone | LG |
| Nickel Vein | NK |
| Nordic | ND |
| Poppy Red | PR |
| Sand | SA |
| Sky Blue | SK |
| Splash | SH |
| Starlight Silver Metallic | SX |
| Warm Grey | WG |
| Wet Sand | WS |

Finish Cards

View color swatches for items listed within this document.

Paints

Plastics/Poly

Wood/Veneer

Laminates

Molded Edges

Edge Styles

Hard Plastics

Glass



Guest Chairs

Jubi™ Color Options

Guest Seating

Jubi™ Chair



JBFCU

| MODEL | Features | MODEL NUMBER | | | | Approx. Packaged Weight |
|---|-------------------------------|--------------|-------------|------------------|-------------|-------------------------|
| | | Basic Model | Shell Color | Upholstery Color | Frame Color | |
| Guest Chair • Fiberglass shell • Pivoting glides | Fiberglass with Uph. Seat Pad | JUBU | JUWH | □□□□□ | □□ | 25.0# |
| | | | | | | |
| | | | | | | |
| | | | | | | |
| | | | | | | |

A **B** **C** **D**

HOW TO ORDER

Indicate the following information on order form:

- Quantity of each item.
- Model number, including options. See "How To Build a Model Number".
- Any special service required.

- Note:
- The □ indicates that a choice is required.
 - The absence of the □ indicates that no choice is required.
 - Alpha-numeric characters in place of □ indicate that no other alternatives are available.

HOW TO BUILD A MODEL NUMBER

- A** Select basic model.
- B** Select fiberglass shell color.
JUWH - White
- C** Select upholstery grade/color.
 Refer to ki.com/fabrics
- D** Select frame color.
 Refer to the **Product Color Options** page in this price list.



Guest Seating

Jubi™ Chair

| Delivered Pricing C.O.M. | Delivered Pricing Fabric Grade 1 | Delivered Pricing Fabric Grade 2 | Delivered Pricing Fabric Grade 3 | Delivered Pricing C.O.V. | Delivered Pricing Vinyl Group 2V | Delivered Pricing Pallas Fabric Group P0 | Delivered Pricing Pallas Fabric Group P1 | Delivered Pricing Pallas Fabric Group P2 | Delivered Pricing Pallas Fabric Group P3 | Delivered Pricing Pallas Fabric Group P4 |
|--------------------------|----------------------------------|----------------------------------|----------------------------------|--------------------------|----------------------------------|--|--|--|--|--|
| \$ 441 | \$ 441 | \$ 470 | \$ 484 | \$ 441 | \$ 484 | \$ 480 | \$ 519 | \$ 541 | \$ 561 | \$ 580 |

SPECIAL SERVICES

Special Carton Marking

With specially marked information N/C

Shipping

Ships **assembled, FOB Green Bay, WI 54302, freight prepaid.** Freight class 250.

Specifications and prices are subject to change without prior notice.

Index

| Model No. | Description | Page | Model No. | Description | Page |
|--------------|--|------|-------------|--|------|
| 1301/NC | Bantam™: Arm Chair | 254 | 04LWAPSPBC | Opt4®: Four-Leg Arm Chair with Casters | 72 |
| 15NAGUW | Versa® Standard: Four-Leg Armless Chair | 230 | 04MSMB | Opt4®: Sled Base Chair | 74 |
| 15NAGUWWS | Versa® Standard: Four-Leg Wallsaver Armless Chair | 230 | 04MSPB | Opt4®: Sled Base Chair | 74 |
| 15NAGW | Versa® Standard: Four-Leg Armless Chair | 220 | 04PSMB | Opt4®: Sled Base Chair | 74 |
| 15NAGWWS | Versa® Standard: Four-Leg Wallsaver Armless Chair | 220 | 04PSPB | Opt4®: Sled Base Chair | 74 |
| 15NASGUW | Versa® Standard: Sled Base Armless Chair | 232 | 04SD.BL | Opt4®: Transport Dolly for Stool | 80 |
| 15NASGW | Versa® Standard: Sled Base Armless Chair | 226 | 04SMSMB | Opt4® Cafe Stools: Cafe Stool | 76 |
| 15TALW | Versa® Standard: Four-Leg Tablet Arm Chair | 224 | 04SMSPB | Opt4® Cafe Stools: Cafe Stool | 76 |
| 15WAGUW | Versa® Standard: Four-Leg Arm Chair | 230 | 04SPSMB | Opt4® Cafe Stools: Cafe Stool | 78 |
| 15WAGUWWS | Versa® Standard: Four-Leg Wallsaver Arm Chair | 230 | 04SPSPB | Opt4® Cafe Stools: Cafe Stool | 78 |
| 15WAGW | Versa® Standard: Four-Leg Arm Chair | 222 | PLAZA | Plaza™ Chair: Stack Chair | 86 |
| 15WAGWWS | Versa® Standard: Four-Leg Wallsaver Arm Chair | 222 | PLAZA.DOLLY | Plaza™ Chair: Transport Dolly | 86 |
| 15WASGUW | Versa® Standard: Sled Base Arm Chair | 232 | PLAZAOD | Plaza™ Chair: Stack Chair with Drain Holes | 86 |
| 15WASGW | Versa® Standard: Sled Base Arm Chair | 228 | PXM | Xylon®: Four-Leg Metal Frame Chair | 248 |
| ACD.BL | Apply® Chairs: Transport Dolly | 12 | RAPD.BL | Rapture® Chairs: Dolly | 92 |
| ALHSNAP | Apply® Cafe Stools: Four-Leg High Back Armless Cafe Stool | 14 | RAPNAP | Rapture® Chairs: Four-Leg Armless Chair | 92 |
| ALLSNAP | Apply® Cafe Stools: Four-Leg Low Back Armless Cafe Stool | 14 | RAPNAPC | Rapture® Chairs: Four-Leg Armless Chair with Casters | 98 |
| ALNAP | Apply® Chairs: Four-Leg Armless Chair | 12 | RAPNAPWS | Rapture® Chairs: Four-Leg Wallsaver Armless Chair | 96 |
| ASNAP | Apply® Chairs: Sled Base Armless Chair | 12 | RAPTALP | Rapture® Chairs: Four-Leg Tablet Arm Chair (Left Hand) | 94 |
| CSD.BL | Maestro® Chairs: Transport Dolly for Poly Chairs | 44 | RAPTARP | Rapture® Chairs: Four-Leg Tablet Arm Chair (Right Hand) | 94 |
| FD.BL | Xylon®: X-Frame Stack Chair Dolly | 248 | RAPWAP | Rapture® Chairs: Four-Leg Arm Chair | 92 |
| GCD.BL | Grazie® Chairs: Transport Dolly | 36 | RAPWAPC | Rapture® Chairs: Four-Leg Arm Chair with Casters | 98 |
| GLCAP | Grazie® Chairs: Four-Leg Cantilever Arm Chair | 26 | RAPWAPWS | Rapture® Chairs: Four-Leg Wallsaver Arm Chair | 96 |
| GLCAPC | Grazie® Chairs: Four-Leg Cantilever Arm Chair with Casters | 26 | S96NAL | Versa® Standard Cafe Stools: Four-Leg Armless Cafe Stool | 234 |
| GLG2APCLH | Grazie® Chairs: Four-Leg Flip-and-Store (G2) Tablet Arm Chair with Casters | 30 | S96WAL | Versa® Standard Cafe Stools: Four-Leg Cafe Stool with Arms | 234 |
| GLG2APLH | Grazie® Chairs: Four-Leg Flip-and-Store (G2) Tablet Arm Chair | 28 | SCDA.BL | Strive® Chairs: Transport Dolly for 4-Leg and Sled Base Chairs | 136 |
| GLNAP | Grazie® Chairs: Four-Leg Armless Chair | 24 | SLCAP | Strive® Chairs: Four-Leg Cantilever Arm Chair | 112 |
| GLNAPC | Grazie® Chairs: Four-Leg Armless Chair with Casters | 24 | SLCAPC | Strive® Chairs: Four-Leg Cantilever Arm Chair with Casters | 112 |
| GLOVTAPCLH | Grazie® Chairs: Four-Leg Flip-up Oversize Tablet Arm Chair with Casters | 30 | SLCAPWS | Strive® Chairs: Four-Leg Wallsaver Cantilever Arm Chair | 124 |
| GLOVTAPLH | Grazie® Chairs: Four-Leg Flip-up Oversize Tablet Arm Chair | 28 | SLCATSU | Strive® Chairs: Four-Leg Cantilever Arm Chair with Top Stitch on Seat | 114 |
| GLSCAP | Grazie® Cafe Stools: Four-Leg Cantilever Arm Cafe Stool | 38 | SLCATSUC | Strive® Chairs: Four-Leg Cantilever Arm Chair with Casters with Top Stitch on Seat | 114 |
| GLSNAP | Grazie® Cafe Stools: Four-Leg Armless Cafe Stool | 38 | SLCATSUWS | Strive® Chairs: Four-Leg Wallsaver Cantilever Arm Chair with Top Stitch on Seat | 126 |
| GLTAPCLH | Grazie® Chairs: Four-Leg Flip-up Tablet Arm Chair with Casters | 30 | SLCAP | Strive® Chairs: Four-Leg Loop Arm Chair | 116 |
| GLTAPLH | Grazie® Chairs: Four-Leg Flip-up Tablet Arm Chair | 28 | SLCAPC | Strive® Chairs: Four-Leg Loop Arm Chair with Casters | 116 |
| GSCAP | Grazie® Chairs: Sled Base Cantilever Arm Chair | 32 | SLCAPWS | Strive® Chairs: Four-Leg Wallsaver Loop Arm Chair | 124 |
| GSG2APLH | Grazie® Chairs: Sled Base Flip-and-Store (G2) Tablet Arm Chair | 34 | SLCATSU | Strive® Chairs: Four-Leg Loop Arm Chair with Top Stitch on Seat | 118 |
| GSNAP | Grazie® Chairs: Sled Base Armless Chair | 32 | SLCATSUC | Strive® Chairs: Four-Leg Loop Arm Chair with Casters with Top Stitch on Seat | 118 |
| GSOVTAPLH | Grazie® Chairs: Sled Base Flip-up Oversize Tablet Arm Chair | 34 | SLCATSUWS | Strive® Chairs: Four-Leg Wallsaver Loop Arm Chair with Top Stitch on Seat | 126 |
| GSTAPLH | Grazie® Chairs: Sled Base Flip-up Tablet Arm Chair | 34 | SLNAP | Strive® Chairs: Four-Leg Armless Chair | 108 |
| IDP/SB | Itoki DP Chair: Chair with Upholstered Seat and Back | 260 | SLNAPC | Strive® Chairs: Four-Leg Armless Chair with Casters | 108 |
| IDP/SO | Itoki DP Chair: Chair with Upholstered Seat Only | 260 | SLNAPWS | Strive® Chairs: Four-Leg Wallsaver Armless Chair | 124 |
| JUBU | Jubi™ Chair: Guest Chair | 266 | SLNATSU | Strive® Chairs: Four-Leg Armless Chair with Top Stitch on Seat | 110 |
| MFSD.BL | Maestro® Chairs: Transport Dolly for Upholstered Chairs | 44 | SLNATSUC | Strive® Chairs: Four-Leg Armless Chair with Casters with Top Stitch on Seat | 110 |
| MSP | Maestro® Chairs: Stack Chair | 44 | SLNATSUWS | Strive® Chairs: Four-Leg Wallsaver Armless Chair with Top Stitch on Seat | 126 |
| MVP.BL | Matrix®: Transport Dolly for Fixed Cushion Chairs | 52 | SLOVTAPLH | Strive® Chairs: Four-Leg Oversize Tablet Arm Chair | 120 |
| MX | Matrix®: Armless Stack Chair | 50 | SLOVTATSULH | Strive® Chairs: Four-Leg Oversize Tablet Arm Chair with Top Stitch on Seat | 122 |
| MXD.BL | Matrix®: Transport Dolly for Poly Chairs | 52 | SLSCAP | Strive® Cafe Stools: Four-Leg Cantilever Arm Cafe Stool | 138 |
| MXTARM/OVS/L | Matrix®: Oversize Flip-Up Tablet Arm | 50 | SLSCATSU | Strive® Cafe Stools: Four-Leg Cantilever Arm Cafe Stool with Top Stitch on Seat | 140 |
| MXTARM/STD/L | Matrix®: Standard Flip-Up Tablet Arm | 50 | SLSLAP | Strive® Cafe Stools: Four-Leg Loop Arm Cafe Stool | 138 |
| 04DA.BL | Opt4®: Transport Dolly for Sled Base Chair | 80 | SLSLATSU | Strive® Cafe Stools: Four-Leg Loop Arm Cafe Stool with Top Stitch on Seat | 140 |
| 04LD.BL | Opt4®: Transport Dolly for Four-Leg Chair | 80 | SLSNAP | Strive® Cafe Stools: Four-Leg Armless Cafe Stool | 138 |
| 04LNAMSMB | Opt4®: Four-Leg Armless Chair | 66 | SLSNATSU | Strive® Cafe Stools: Four-Leg Armless Cafe Stool with Top Stitch on Seat | 140 |
| 04LNAMSMBC | Opt4®: Four-Leg Armless Chair with Casters | 58 | SLTAPLH | Strive® Chairs: Four-Leg Tablet Arm Chair | 120 |
| 04LNAMSPB | Opt4®: Four-Leg Armless Chair | 66 | SLTATSULH | Strive® Chairs: Four-Leg Tablet Arm Chair with Top Stitch on Seat | 122 |
| 04LNAMSPBC | Opt4®: Four-Leg Armless Chair with Casters | 58 | SNCAP | Strive® Nesting Chairs: Arm Chair with Poly Seat | 154 |
| 04LNAPSMB | Opt4®: Four-Leg Armless Chair | 66 | SNCATSU | Strive® Nesting Chairs: Arm Chair with Upholstered Seat with Top Stitch on Seat | 156 |
| 04LNAPSMBBC | Opt4®: Four-Leg Armless Chair with Casters | 58 | | | |
| 04LNAPSPB | Opt4®: Four-Leg Armless Chair | 66 | | | |
| 04LNAPSPBC | Opt4®: Four-Leg Armless Chair with Casters | 58 | | | |
| 04LWAMSMB | Opt4®: Four-Leg Arm Chair | 70 | | | |
| 04LWAMSMBBC | Opt4®: Four-Leg Arm Chair with Casters | 72 | | | |
| 04LWAMSPB | Opt4®: Four-Leg Arm Chair | 70 | | | |
| 04LWAMSPBC | Opt4®: Four-Leg Arm Chair with Casters | 72 | | | |
| 04LWAPSMB | Opt4®: Four-Leg Arm Chair | 70 | | | |
| 04LWAPSMBC | Opt4®: Four-Leg Arm Chair with Casters | 72 | | | |
| 04LWAPSPB | Opt4®: Four-Leg Arm Chair | 70 | | | |



| Model No. | Description | Page | Model No. | Description | Page |
|-------------|---|------|-----------|-------------|------|
| SNCAU | Strive® Nesting Chairs: Arm Chair with Upholstered Seat | 154 | | | |
| SNNAP | Strive® Nesting Chairs: Armless Chair with Poly Seat | 154 | | | |
| SNNATSU | Strive® Nesting Chairs: Armless Chair with Upholstered Seat with Top Stitch on Seat | 156 | | | |
| SNNAU | Strive® Nesting Chairs: Armless Chair with Upholstered Seat | 154 | | | |
| SNOVTAPRH | Strive® Nesting Chairs: Oversize Tablet Arm Chair with Poly Seat | 158 | | | |
| SNOVTATSULH | Strive® Nesting Chairs: Oversize Tablet Arm Chair with Upholstered Seat with Top Stitch on Seat | 160 | | | |
| SNOVTAURH | Strive® Nesting Chairs: Oversize Tablet Arm Chair with Upholstered Seat | 158 | | | |
| SNTAPRH | Strive® Nesting Chairs: Tablet Arm Chair with Poly Seat | 158 | | | |
| SNTATSULH | Strive® Nesting Chairs: Tablet Arm Chair with Upholstered Seat with Top Stitch on Seat | 160 | | | |
| SNTAURH | Strive® Nesting Chairs: Tablet Arm Chair with Upholstered Seat | 158 | | | |
| SRAPNAP | Rapture® Cafe Stools: Four-Leg Armless Cafe Stool | 100 | | | |
| SRAPWAP | Rapture® Cafe Stools: Four-Leg Cafe Stool with Arms | 100 | | | |
| SSCAP | Strive® Chairs: Sled Base Cantilever Arm Chair | 128 | | | |
| SSCATSU | Strive® Chairs: Sled Base Cantilever Arm Chair with Top Stitch on Seat | 130 | | | |
| SSNAP | Strive® Chairs: Sled Base Armless Chair | 128 | | | |
| SSNATSU | Strive® Chairs: Sled Base Armless Chair with Top Stitch on Seat | 130 | | | |
| SSOVTAPLH | Strive® Chairs: Sled Base Oversize Tablet Arm Chair | 132 | | | |
| SSOVTATSULH | Strive® Chairs: Sled Base Oversize Tablet Arm Chair with Top Stitch on Seat | 134 | | | |
| SSTALTSU | Strive® Chairs: Sled Base Tablet Arm Chair with Top Stitch on Seat | 134 | | | |
| SSTAPLH | Strive® Chairs: Sled Base Tablet Arm Chair | 132 | | | |
| SWNA | Strive® High Density Stack Chair: Armless Chair | 146 | | | |
| SWNATSU | Strive® High Density Stack Chair: Armless Chair with Top Stitch on Seat | 148 | | | |
| SWTAL | Strive® High Density Stack Chair: Standard Flip-Up Tablet Arm | 146 | | | |
| TALNA | Torsion Air®: Four-Leg Armless Chair | 188 | | | |
| TALTAL | Torsion Air®: Four-Leg Tablet Arm Chair | 188 | | | |
| TALWA | Torsion Air®: Four-Leg Arm Chair | 188 | | | |
| TANNA | Torsion Air® Nesting Chairs: Armless Chair | 196 | | | |
| TANTALFT | Torsion Air® Nesting Chairs: Flip-up Tablet Arm Chair | 196 | | | |
| TANTALPT | Torsion Air® Nesting Chairs: Piretti Tablet Arm Chair | 198 | | | |
| TANWA | Torsion Air® Nesting Chairs: Arm Chair | 196 | | | |
| TASNA | Torsion Air®: Sled Base Armless Chair | 190 | | | |
| TASTAL | Torsion Air®: Sled Base Tablet Arm Chair | 190 | | | |
| TASWA | Torsion Air®: Sled Base Arm Chair | 190 | | | |
| TGNAPB | Torsion® on the Go!® Nesting Chairs: Armless Chair with Poly Back | 166 | | | |
| TGNAUB | Torsion® on the Go!® Nesting Chairs: Armless Chair with Upholstered Back | 166 | | | |
| TGTALPB | Torsion® on the Go!® Nesting Chairs: Tablet Arm Chair with Poly Back | 168 | | | |
| TGTALUB | Torsion® on the Go!® Nesting Chairs: Tablet Arm Chair with Upholstered Back | 168 | | | |
| TGWAPB | Torsion® on the Go!® Nesting Chairs: Arm Chair with Poly Back | 166 | | | |
| TGWAUB | Torsion® on the Go!® Nesting Chairs: Arm Chair with Upholstered Back | 166 | | | |
| TLD.BL | Torsion®: Transport Dolly for Four-Leg Chairs | 182 | | | |
| TLFAP | Torsion®: Four-Leg Arm Chair | 174 | | | |
| TLG2ALP | Torsion®: Four-Leg G2-Tablet Arm Chair | 176 | | | |
| TLNAP | Torsion®: Four-Leg Armless Chair | 174 | | | |
| TLTALP | Torsion®: Four-Leg Tablet Arm Chair | 176 | | | |
| TSFAP | Torsion®: Full Sled Base Arm Chair | 178 | | | |
| TSG2ALP | Torsion®: Full Sled Base G2-Tablet Arm Chair | 180 | | | |
| TSNAP | Torsion®: Full Sled Base Armless Chair | 178 | | | |
| TSTALP | Torsion®: Full Sled Base Tablet Arm Chair | 180 | | | |
| TVD.BL | Torsion®: Transport Dolly for Sled Base Chairs | 182 | | | |
| VBD.BL | Versa® Basic: Versa® Basic Transport Dolly | 204 | | | |
| VBNAL | Versa® Basic: Four-Leg Armless Chair | 204 | | | |
| VBWAL | Versa® Basic: Four-Leg Arm Chair | 204 | | | |
| VCNAL | Versa® Conference: Four-Leg Armless Chair | 212 | | | |
| VCWAG | Versa® Conference: Four-Leg Arm Chair | 210 | | | |
| VXLAG | Versa® XL: Four-Leg Arm Chair | 242 | | | |
| VXLAGWS | Versa® XL: Four-Leg Wallsaver Arm Chair | 242 | | | |
| VXLN | Versa® XL: Four-Leg Armless Chair | 240 | | | |
| VXLNWS | Versa® XL: Four-Leg Wallsaver Armless Chair | 240 | | | |



KI
1330 Bellevue Street
P.O. Box 8100
Green Bay, Wisconsin 54308-8100
1-800-424-2432
www.ki.com

KI and Furnishing Knowledge
are registered trademarks
of Krueger International, Inc.

© 2011 KI
All Rights Reserved.
Litho in USA.
Code KI-11479R2/KI/VL/211

Printed using only water-based inks,
including metallics. Please recycle.