

# Assembly Instructions

## CrossRoads® Study Carrel

April 2006

### CrossRoads Study Carrel

#### Tools Required:

- #2 Phillips screwdriver
- Socket wrench

#### Hardware Included:

- 1/2" machine screws
- #10 x 3/8" screws
- 1" Phillips head screws

#### For Single Face Study Carrel With Power Module or Grommet

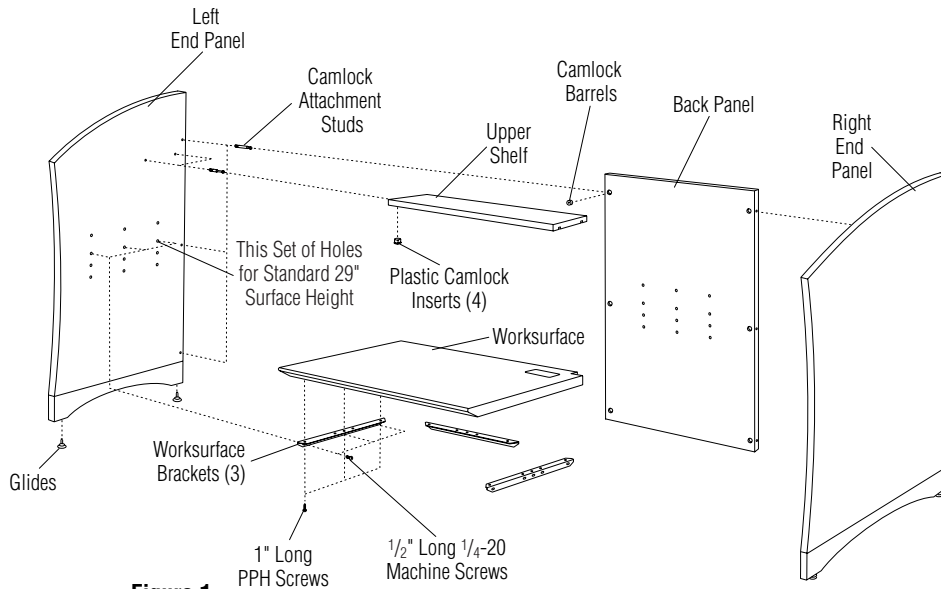

Figure 1

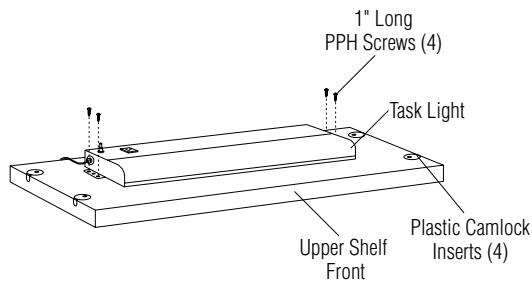

Figure 2

**Two-person upright assembly is recommended for safety and efficiency.**



Assemble units as described herein only. To do otherwise may result in instability. All screws, nuts and bolts must be tightened securely and must be checked periodically after assembly. Failure to assemble properly, or to secure parts may result in assembly failure and injury.

1. Tip end panel up and insert glides in bottom.
  2. Support end panel in an upright position with brass inserts to the inside and curve to front (if curved).
  3. Insert three camlock attachment studs in end panel and tighten (Figure 1).
  4. Insert camlock barrels into the pre-drilled holes in the back panel if not already done.
  5. Align camlock barrels on the back panel with camlock attachment studs on the end panel. Insert and tighten.
  6. Repeat steps 1 through 5 for each adder panel (or final end panel).
  7. Install three worksurface brackets (one each on the end panel, adder panel and back panel) at the selected height. Fasten with 1/2" machine screws (3 screws per bracket).
- Note:** ADA units will have 4 pre-drilled holes (use the highest set). All other units will have pre-drilled holes for 25", 27" and 29" heights (Figure 1).
8. Place the worksurface on the brackets (laminated side up). Align the pre-drilled holes and fasten to each bracket with 1" Phillips head screws (3 screws per bracket).
  9. For upper shelf without task light – Insert two camlock studs in each end and/or adder panel. Insert four plastic camlock inserts into each upper shelf. Set shelf onto upper shelf camlock studs. Tighten (Figure 2).
  10. For upper shelf with optional task light – Insert two camlock studs in each end and/or adder panel. Insert four plastic camlock inserts into each upper shelf (Figure 2). Position the upper shelf on flat surface with the faceplate facing up and toward the front. Center the task light on the



**WORKING  
FOR  
YOU**

# ■ CrossRoads® Study Carrel

## Assembly Instructions



Assemble units as described herein only. To do otherwise may result in instability. All screws, nuts and bolts must be tightened securely and must be checked periodically after assembly. Failure to assemble properly, or to secure parts may result in assembly failure and injury.

underside of the upper shelf with the electrical cord facing the back. Fasten with two 1" Phillips head screws per side. Turn shelf over and set onto upper shelf camlock studs (faceplate facing the front). Tighten. Thread the electrical cord into the notched corner of the worksurface. Attach self-adhesive upper wire manager into right corner of the carrel (flush to the worksurface) with the open edge to the inside of the carrel (Figure 3). For ADA height units, the upper wire manager needs to be slid into place from below the work surface. Place electrical cord inside the wire manager.

11. Attach self-adhesive lower wire manager to lower right corner of study unit. Place any electrical cords inside wire manager (Figure 3).

12. Position the mounting holes of the wire management trough over the pre-drilled holes in the worksurface. Secure the trough to the worksurface with #10 x 5/8" screws. Do not over tighten screws. From the underside of worksurface, position trough clips over the pre-drilled holes in the worksurface and secure with two #10 x 5/8" screws per clip (Figure 4).

13. Snap the power & data module (or grommet) into place on the top of the worksurface with the electrical cord feeding through grommet opening (Figure 5).

14. Route the module cord (or other electrical cords or data lines) through either end of the wire management trough. If a cord is to be routed the opposite direction that it comes out of the module/grommet, make a 6" loop with the cord to change direction (Figure 5).

15. Slide the flange of the wire management trough under the trough clips to secure the trough to the worksurface. Store any excess cord in the wire management trough.

16. Repeat steps 7 through 15 for each study unit.

**Note:** wire management trough is not to be used for routing extension cords.

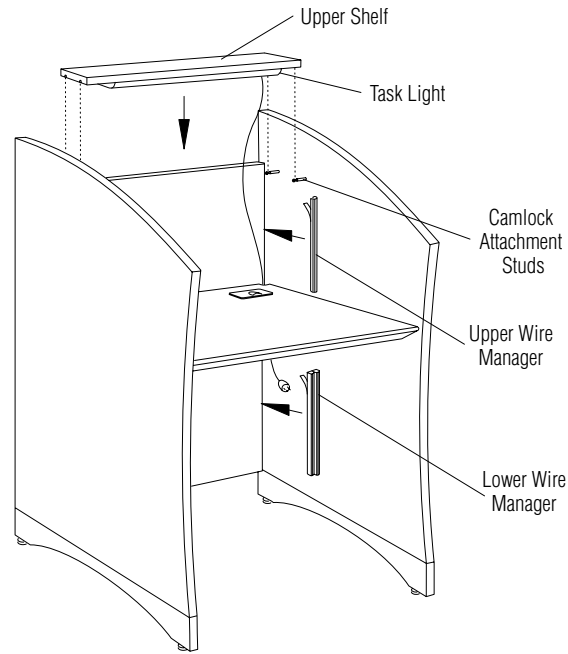

Figure 3

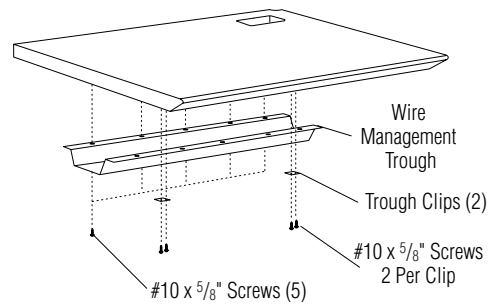

Figure 4

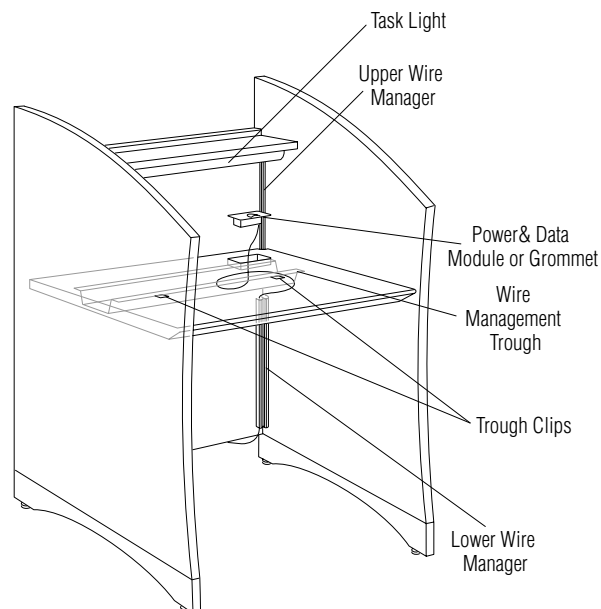

Figure 5



Assemble units as described herein only. To do otherwise may result in instability. All screws, nuts and bolts must be tightened securely and must be checked periodically after assembly. Failure to assemble properly, or to secure parts may result in assembly failure and injury.

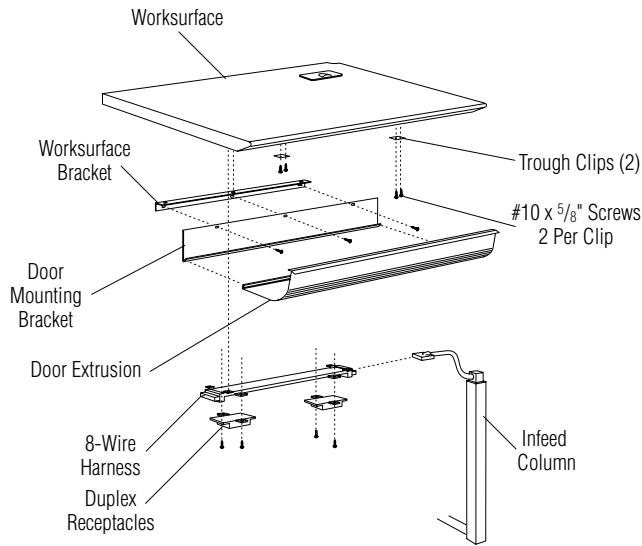

Figure 6

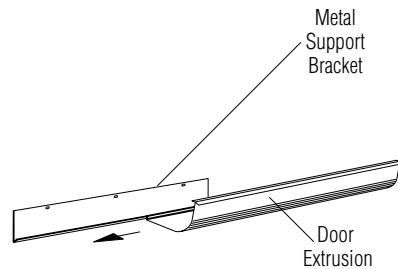

Figure 7

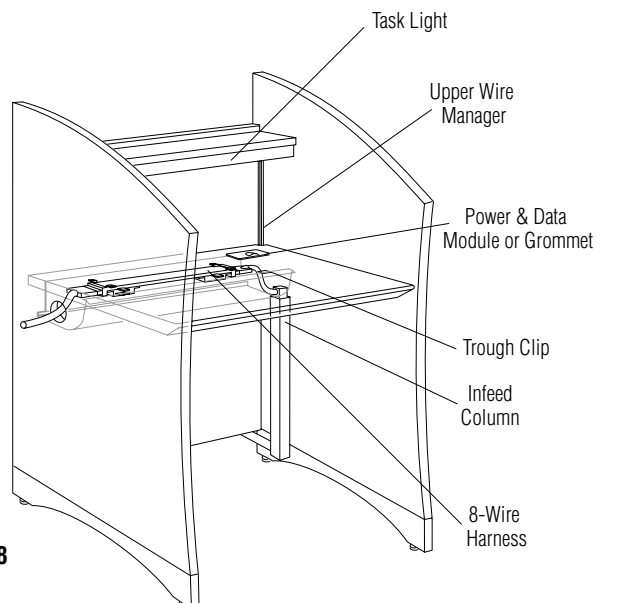

Figure 8

**For Single Face Study Carrel With Single-Circuit, Multi-Circuit or New York Infeed Boxes Complete Steps 1 Through 10.**

**Note:** The combined length of the interconnected tables shall not exceed 30 feet. Do not make any connections to a power source until all steps below are followed and the electrical integrity of the finished system is inspected.

11. Attach the power entry infeed column to the inside corner of the study unit (below the worksurface) on the end closest to the power source (Figure 6). When a row of carrels feed from the same power source, the first carrel is the only one that requires the power entry column.
12. Position the 8-wire harness centered on the underside of the worksurface. Attach the 8-wire harness with screws provided in the kit.
13. Plug in the optional duplex receptacle to the 8-wire harness and attach with screws.
14. Insert the optional table-to-table connector (for carrel-to-carrel power) into the 8-wire harness and feed it through the opening in the adder panel.
15. Slide the plastic door extrusion onto metal support bracket (Figure 7).
16. Align holes in the metal support bracket with the screws/holes in the worksurface support bracket (previously attached on the back panel) and re-fasten the screws.
17. Attach door clips into pre-drilled holes, two clips per door.
18. Snap the power & data module into place on the top of the worksurface with the electrical cord feeding through grommet opening (Figure 8). Plug the cord into the optional duplex receptacle.
19. Repeat steps 11 through 18 for each study unit.

# CrossRoads® Study Carrel

## Assembly Instructions



Assemble units as described herein only. To do otherwise may result in instability. All screws, nuts and bolts must be tightened securely and must be checked periodically after assembly. Failure to assemble properly, or to secure parts may result in assembly failure and injury.

### For Double Face Study Carrel With Power Module or Grommet

**Note:** end panels and adder panels for double face carrels have unfinished back edges that are positioned end-to-end, and divider panels are used instead of back panels.

Complete steps 1 through 15 of the instructions for Single Face Study Carrel With Single-Circuit Electrical.

16. Insert glides in the bottom of the facing end panel.
17. Insert 3 larger camlock attachment studs (for divider panel) in the facing end panel and tighten (Figure 9).
18. Align the 3 larger camlock attachment studs in the facing end panel with the pre-drilled holes in the first end panel and removed without the use of tools. (end panels are positioned end-to-end) and tighten.
19. Repeat steps 16 through 18 for the facing adder panel (adder panels positioned end-to-end).
20. Take a second divider panel and insert six camlock barrels into the pre-drilled holes.
21. Align the six camlock barrels on the second divider panel with the six camlock studs (three studs in each adder panel) and tighten.
22. Continue adding adder panels, facing adder panels and divider panels to complete the row of double face carrels (ending the row with end panels instead of adder panels).

Continue with steps 7 through 15 from the Study Carrel Single Face assembly instructions for each study unit.

### For Double Face Study Carrel With Single-Circuit, Multi-Circuit or New York City Infeed Boxes

**Note:** The combined length of the interconnected tables shall not exceed 30 feet. Do not make any connections to a power source until all steps below are followed and the electrical integrity of the finished system is inspected.

Complete steps 1 through 19 of the instructions for Single Face Study Carrel With Single-Circuit, Multi-Circuit or New York City Infeed Boxes, treating each face of the carrels separately.

#### New York City Guidelines

- A. All wiring must be installed by an electrician licensed in New York City.
- B. All branch circuit wiring must be #12 AWG minimum.
- C. Each branch circuit must be fused at 15 AMP maximum with no more than 10 outlets per circuit.

- D. A service entry box must be provided with a service panel. The box size must be approximately 2.25 cubic inches for each #12 AWG wire entering the box plus 2.25 cubic inches for each #12 AWG wire leaving the box.
- E. Flexible metal liquid-tight conduit (customer supplied) from the supply source to the panel may not exceed 18 inches in length and must be hardwired at both ends, per Article 4 of the New York Electrical Code.
- F. If task lights are part of the electrified panel system, the Advisory Board submission must include a sketch showing how the task lights are installed and removed without the use of tools.

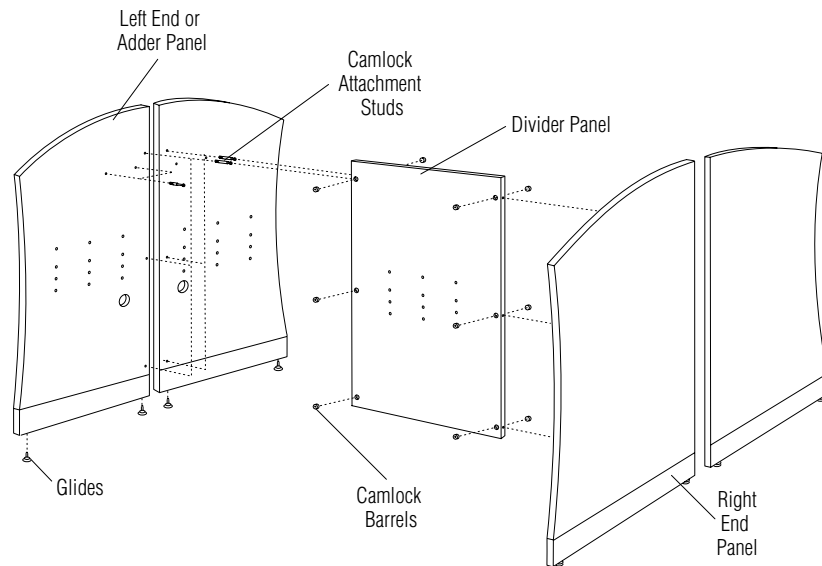

Figure 9

