

Assembly Instructions

CrossRoads® Shelving

Double Face Metal with Back Stop

December 2009

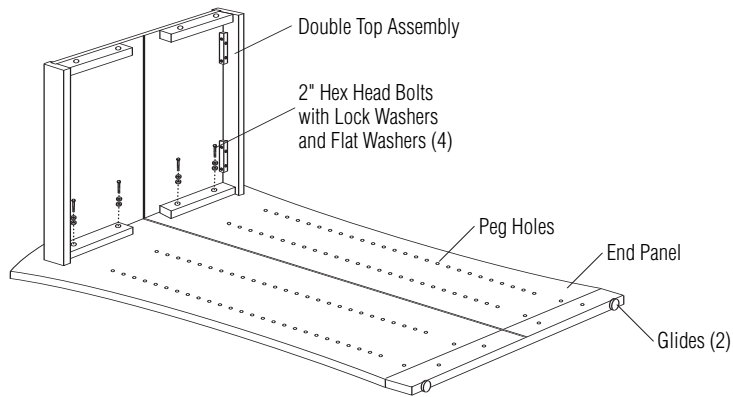

Figure 1

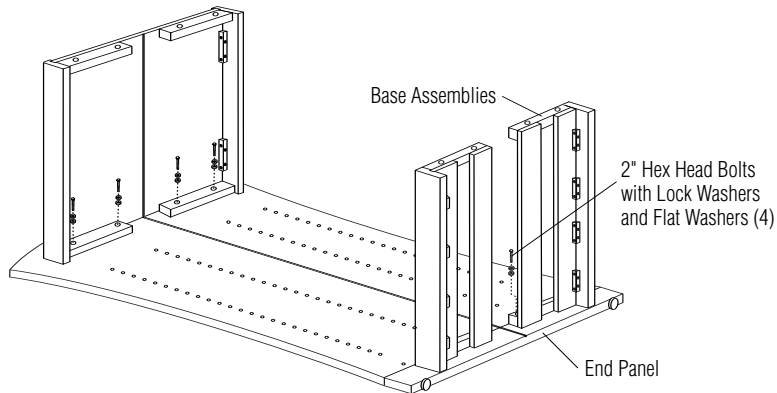

Figure 2

Tools Required:

- #2 Phillips screwdriver
- $\frac{1}{2}$ " socket
- Socket wrench

Hardware Included:

- #8 x $\frac{5}{8}$ " screws
- #8 x $\frac{1}{4}$ " screws
- $\frac{5}{16}$ " x 2" hex head bolt
- $\frac{5}{16}$ " x $\frac{4}{2}$ " hex head bolt
- $\frac{1}{4}$ " flat washer
- $\frac{5}{16}$ " lock washer
- $\frac{5}{16}$ " flat washer
- $\frac{5}{16}$ " hex nut
- Metal pegs

1. Set one end panel on flat surface with the peg holes up.
2. Position the double top assembly, routed side down on end panel. Align the pre-drilled holes with the inserts. Fasten with $\frac{5}{16}$ " x 2" hex head bolts and washers (Figure 1). **Note:** for shelving units 72" and higher, the top shelf assembly should be flipped so that the cleat side faces up.
3. Position the base assemblies by aligning the holes so that the bottoms of the base assembly facings are flush with the bottom of the end panel. Fasten with 2" hex head bolts and washers (Figure 2).



Assemble units as described herein only. To do otherwise may result in instability. All screws, nuts and bolts must be tightened securely and must be checked periodically after assembly. Failure to assemble properly, or to secure parts may result in assembly failure and injury.



CrossRoads® Shelving - Double Face Metal with Back Stop

Assembly Instructions



Assemble units as described herein only. To do otherwise may result in instability. All screws, nuts and bolts must be tightened securely and must be checked periodically after assembly. Failure to assemble properly, or to secure parts may result in assembly failure and injury.

4. Position adder panel (has holes on both sides) by aligning the upper holes with the holes in the previously installed top assembly (Figure 5). Position the top assembly for the adder unit by aligning the holes with the holes in the adder panel.

5. Insert four 4 1/2" hex head bolts with a lock washer and a flat washer from the inside of the top assembly through the adder panel and previously installed top assembly (Figure 6). Tighten.

6. Position the base assemblies for the adder unit by aligning the holes with the holes in the adder panel. Insert four 4 1/2" hex head bolts with a lock washer and a flat washer from the inside of the base assemblies through the adder panel and previously installed base assemblies (Figure 6). Tighten.

7. Repeat steps 4, 5 and 6 until all units are assembled, finish with the right end panel. Note that two or more assemblers are recommended when multiple units are connected.

8. Raise assembled unit to upright position.

9. Rest shelf on four metal pegs. Attach fixed shelf with #8 x 5/8" screws and two 1/4" flat washers per screw to the end panels (Shelf Detail).

10. Bottom shelf. Insert (4) metal pegs into pre-drilled holes just above the base assembly. Lay bottom shelf with routed side down routed grooves rest on the pegs and align onto metal pegs. Repeat for each unit. (Figure 6).

11. Set each shelf onto the metal pegs with notched side down. Repeat for each shelf (Figure 6 and Shelf Detail).

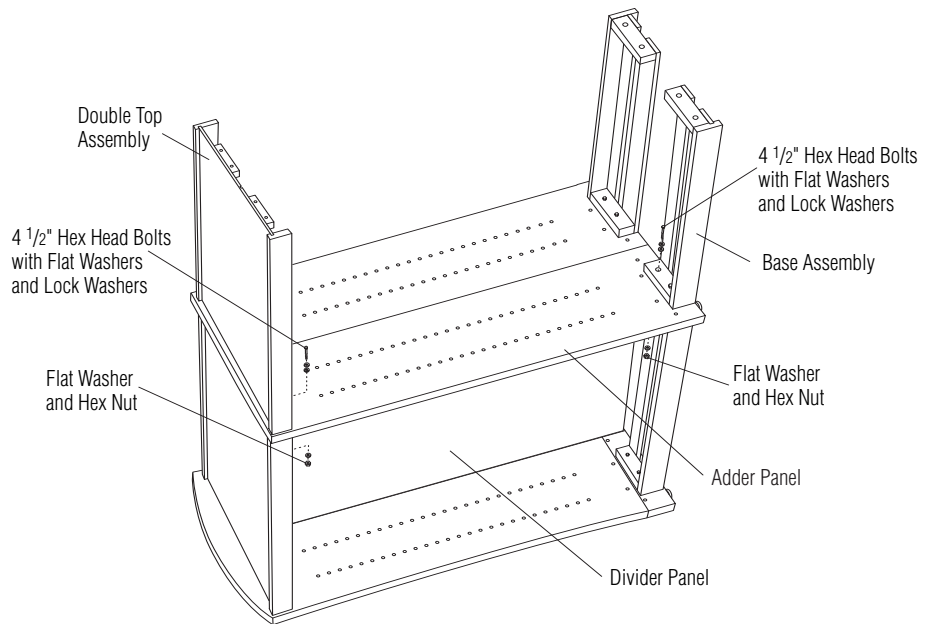

Figure 5

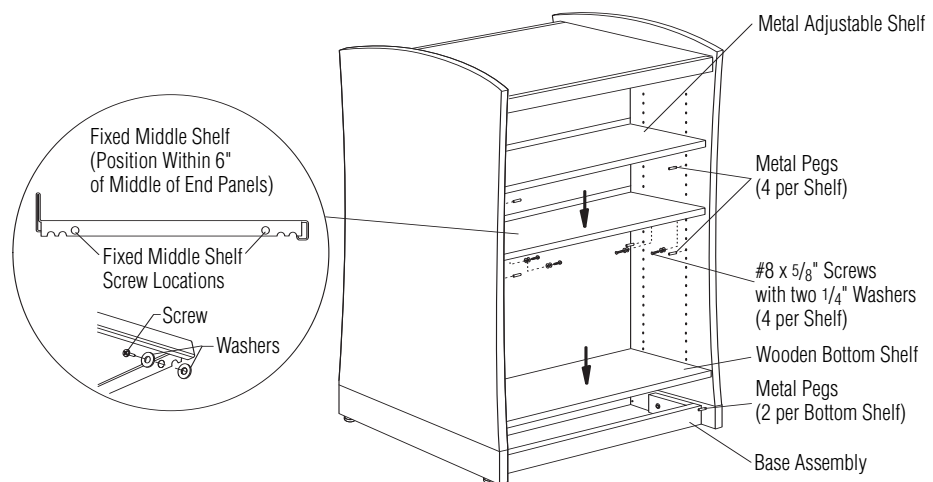

Figure 6



Shelf Detail