

Assembly Instructions

CrossRoads® Metal Media Shelving

Double Face

December 2009

Tools Required:

- #2 Phillips screwdriver
- 1/2" socket
- Socket wrench

Hardware Included:

- #8 x 5/8" screws
- #8 x 1 1/4" screws
- 5/16" x 2" hex head bolt
- 5/16" x 4 1/2" hex head bolt
- 5/16" lock washer
- 5/16" flat washer
- 5/16" hex nut
- Metal pegs

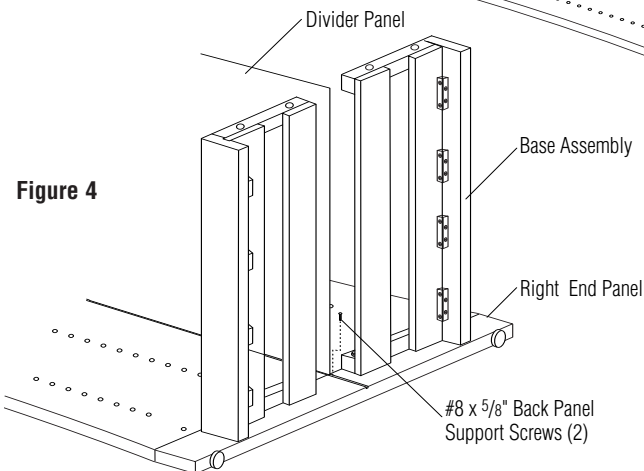
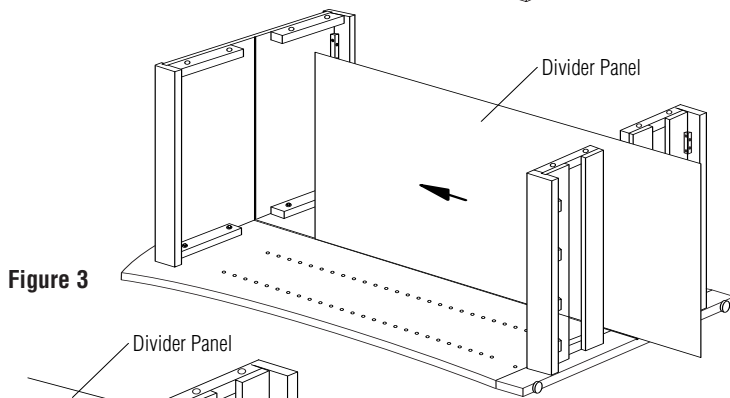
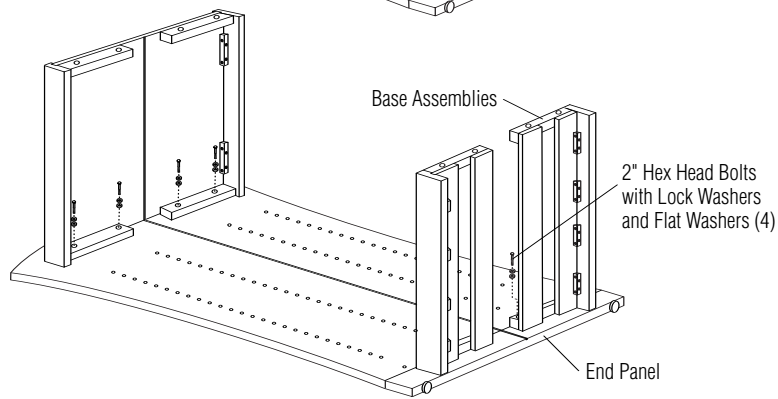
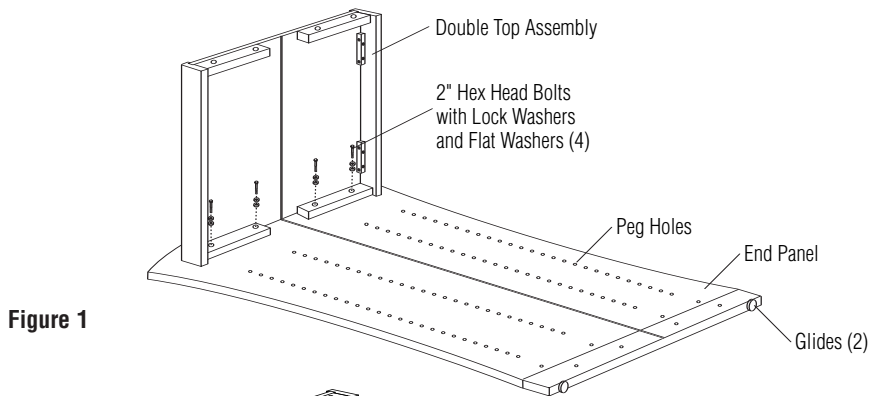

1. Set one end panel on flat surface with the peg holes up.
2. Position the double top assembly, routed side down on end panel. Align the pre-drilled holes with the inserts. Fasten with 5/16" x 2" hex head bolts and washers (Figure 1). **Note:** for shelving units 72" and higher, the top shelf assembly should be flipped so that the routed side faces up.
3. Position the base assemblies by aligning the holes so that the bottoms of the base assembly facings are flush with the bottom of the end panel. Fasten with 2" hex head bolts and washers (Figure 2).
4. For optional divider panel, slide the starter divider panel into the center groove of the end panel and top assembly. Insert #8 x 5/8" screws into the groove directly below the divider panel to keep the panel raised off the floor (Figures 3 & 4).



Assemble units as described herein only. To do otherwise may result in instability. All screws, nuts and bolts must be tightened securely and must be checked periodically after assembly. Failure to assemble properly, or to secure parts may result in assembly failure and injury.

CrossRoads® Metal Media Shelving - Double Face

Assembly Instructions



Assemble units as described herein only. To do otherwise may result in instability. All screws, nuts and bolts must be tightened securely and must be checked periodically after assembly. Failure to assemble properly, or to secure parts may result in assembly failure and injury.

5. Position adder panel (has holes on both sides) by aligning the upper holes with the holes in the previously installed top assembly (Figure 5). Check that the divider panel is still positioned in the center groove. Position the top assembly for the adder unit by aligning the holes with the holes in the adder panel.

6. Insert four 4 1/2" hex head bolts with a lock washer and a flat washer from the inside of the top assembly through the adder panel and previously installed top assembly (Figure 5). Tighten.

7. Position the base assemblies for the adder unit by aligning the holes with the holes in the adder panel. Insert four 4 1/2" hex head bolts with a lock washer and a flat washer from the inside of the base assembly through the adder panel and previously installed base assembly (Figure 6). Tighten.

8. For optional divider panel, slide the adder divider panel into the center groove of each of the adder panel assemblies. Insert #8 x 5/8" screws into the groove directly below the divider panel to keep the panel raised off the floor.

9. Repeat steps 5, 6, 7, 8 and 9 until all units are assembled, finishing with the right end panel. **Note:** two or more assemblers are recommended when multiple units are connected.

10. Carefully tip the shelving unit into an upright position. **Note:** two or more assemblers are recommended when multiple units are connected.

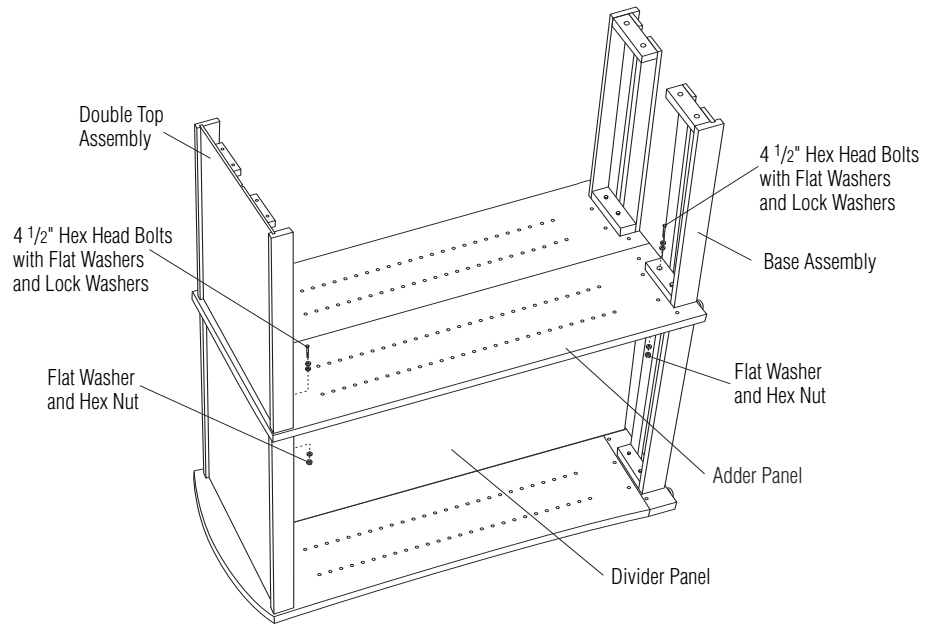

Figure 5

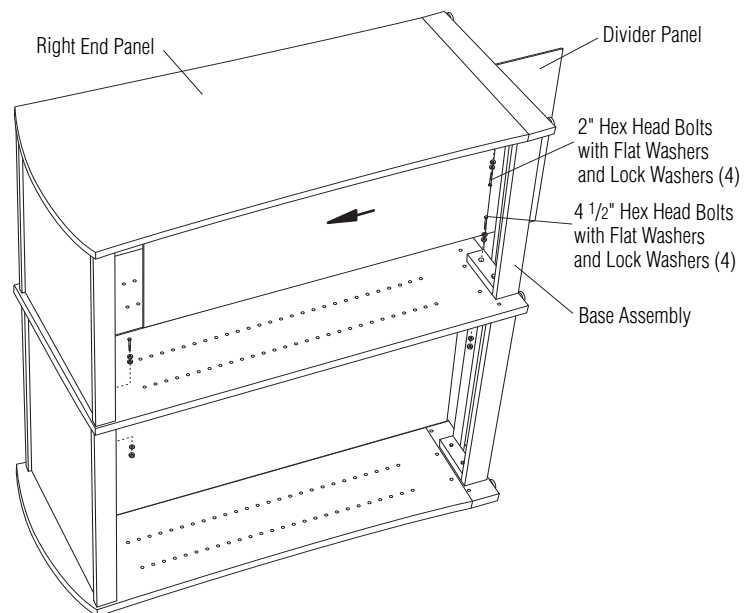

Figure 6



Assemble units as described herein only. To do otherwise may result in instability. All screws, nuts and bolts must be tightened securely and must be checked periodically after assembly. Failure to assemble properly, or to secure parts may result in assembly failure and injury.

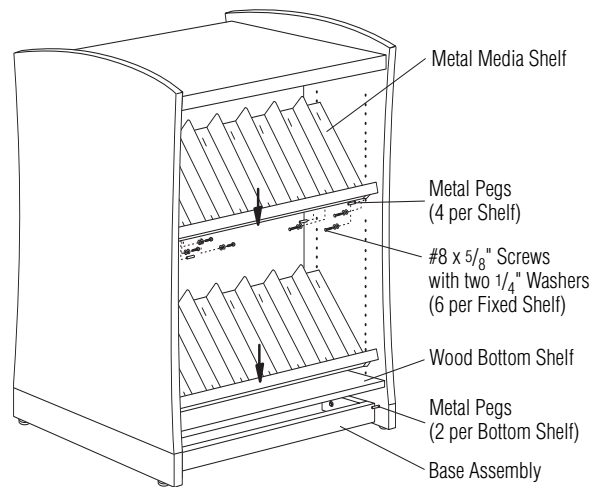

Figure 7

11. Wood Bottom Shelf. Insert (4) metal pegs into pre-drilled holes just above the base assembly. Lay bottom shelf with routed side down and align onto metal pegs (Figure 7). Repeat for each unit.
12. 60" and 82" high units require a fixed center metal shelf. Measure up half way on the end panels. Within 6" of this dimension, determine desired shelf location. Insert (2) metal pegs into pre-drilled holes at front sides of end/adder panels at desired shelf height. At back side of end/adder panels, insert (2) metal pegs five holes up from the placement of the front metal pegs. Set center metal media shelf onto the pegs. Attach center shelf to end/adder panel using three #8 x 5/8" screws and washers per side (Figure 8). Metal shelves must be tight against end/adder panel when screw is fully tightened.
12. Metal media shelves. Insert (2) metal pegs into pre-drilled holes at front sides of end/adder panels at desired shelf heights. At back side of end/adder panels, insert (2) metal pegs five holes up from the placement of the front metal pegs. Set each metal media shelf onto the pegs (Figure 7).
13. Optional dividers. Insert metal dividers into desired slots on each metal media shelf (six dividers provided per shelf).

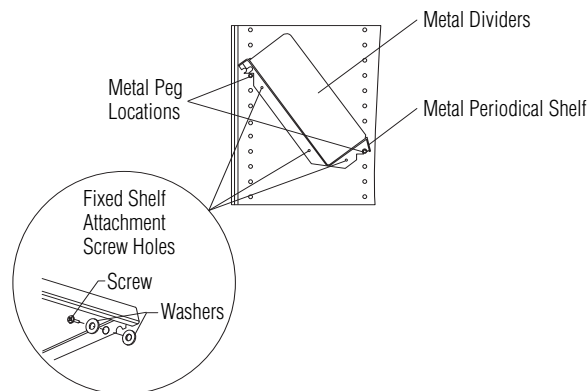

Figure 8

**You make the rules.
We make the rest.®**

Of course KI solutions work better for you. They're made for you. No one pays more attention to customer needs than we do. We don't design our furniture to win awards (even though it does). We don't rely on one-size-fits-all solutions (even though they would make our life easier). We find out what the market needs. And, we make it. The same applies to our service, distribution...everything we do. KI solutions work, because we're working for you.

KI
1330 Bellevue Street
P. O. Box 8100
Green Bay, Wisconsin 54308-8100
1-800-424-2432
www.ki.com

KI and Furnishing Knowledge
are registered trademarks
of Krueger International, Inc.

© 2009 KI
All Rights Reserved.
Litho in USA.
Code KI-61563BR4-MM/TMI/PDF/1209

