

Assembly Instructions

CrossRoads® Panel Leg Table

April 2009

CrossRoads Panel Leg Table

Tools Required:

- #2 Phillips screwdriver
- Power drill
- 1/8" drill bit

Hardware Included:

- 5" angle bracket
- 21" angle bracket
- #8 x 3/4" screws
- #8 x 1 1/2" screws
- 6MM x 10MM screws

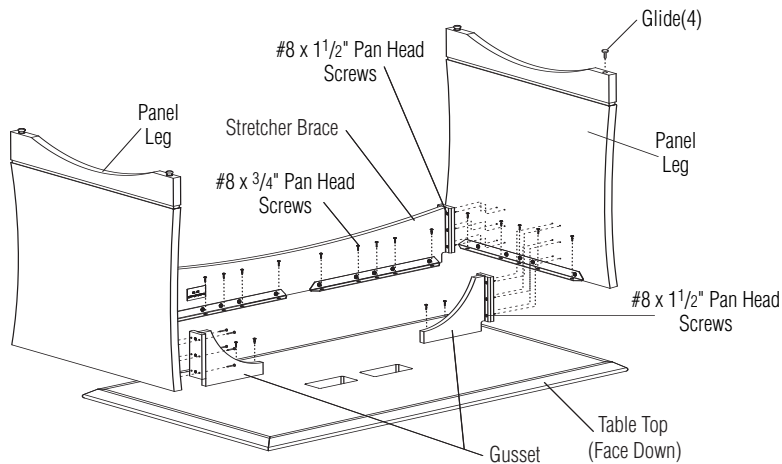
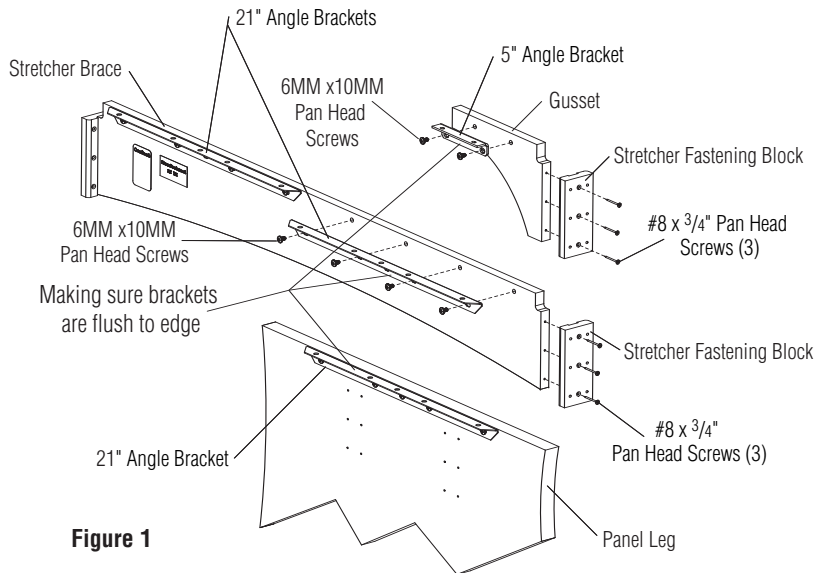

1. Attach stretcher fastening blocks to the stretcher brace and gussets by placing in slot and fasten with #8 x 3/4" screws (Figure 1).
2. Install 21" angle brackets in pre-drilled holes in the stretcher brace and end panel legs with 6MM x 10MM screws. Install 5" angle brackets in pre-drilled holes in the gussets with 6MM x 10MM screws. Make sure all brackets are flush with the top edge.
3. Place table top upside down onto a soft protective surface (Figure 2).
4. Attach stretcher brace and gussets to end panel legs in pre-drilled holes with #8 x 1 1/2" screws (Figure 2).
5. Center the panel leg assembly on the top. Pre-drill with 1/8" drill bit and screw down with #8 x 3/4" screws (Caution! Do not drill through the top).
6. With table still inverted, insert the glides into the panel legs (2 per side).
7. Tip table upright if not adding electrical options.



Assemble units as described herein only. To do otherwise may result in instability. All screws, nuts and bolts must be tightened securely and must be checked periodically after assembly. Failure to assemble properly, or to secure parts may result in assembly failure and injury.

CrossRoads® Panel Leg Table

Assembly Instructions



Assemble units as described herein only. To do otherwise may result in instability. All screws, nuts and bolts must be tightened securely and must be checked periodically after assembly. Failure to assemble properly, or to secure parts may result in assembly failure and injury.

For Panel Leg Table With Power Module or Grommet

Tools Required:

- #2 Phillips screwdriver

Hardware Included:

- #10 x 5/8" screws
- 1 1/2" wood screws

1. Attach the standard plastic, self-adhesive, vertical wire manager to the inside of the panel closest to the power source. Place any electrical cords inside the vertical wire manager (Figure 3).
2. Position the mounting holes of the wire management trough over the pre-drilled holes in the worksurface. Secure the trough to the worksurface with #10 x 5/8" screws. Do not over tighten screws. From the underside of worksurface, position trough clips over the pre-drilled holes in the worksurface and secure with two #10 x 5/8" screws per clip.
3. Tip table upright. Snap the power & data module (or grommet) into place with the electrical cord feeding through grommet opening (Figure 4).
4. Route the module cord (or other electrical cords or data lines) through either end of the wire management trough. If a cord is to be routed the opposite direction that it comes out of the module/grommet, make a 6" loop with the cord to change direction.
5. Slide the flange of the wire management trough under the trough clips to secure the trough to the worksurface. Store any excess cord in the wire management trough.
6. For ganged and/or electrically interconnected tables, attach two wood ganger blocks with 1 1/2"-long wood screws to the underside of the table top on each end (Figure 5).

Note: wire management trough is not to be used for routing extension cords. All table connections must be securely fastened before electrical connections between work surfaces are installed.

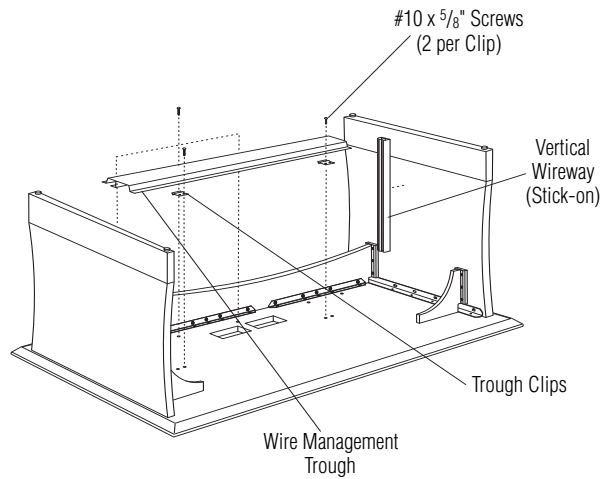

Figure 3

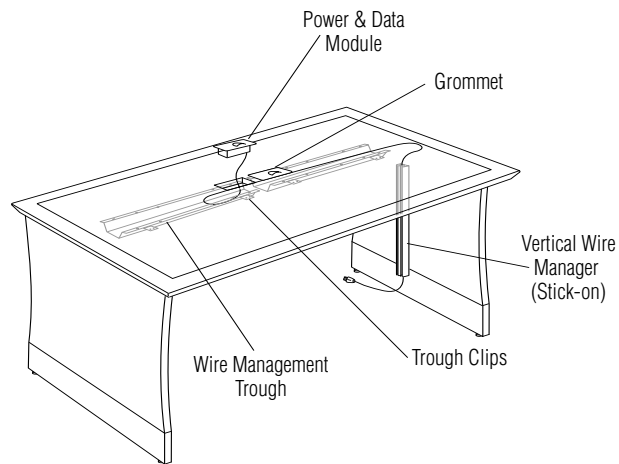

Figure 4

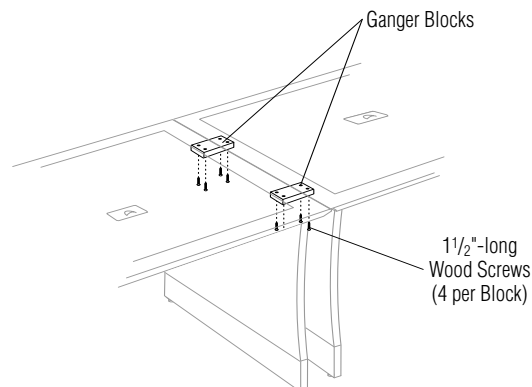

Figure 5



Assemble units as described herein only. To do otherwise may result in instability. All screws, nuts and bolts must be tightened securely and must be checked periodically after assembly. Failure to assemble properly, or to secure parts may result in assembly failure and injury.

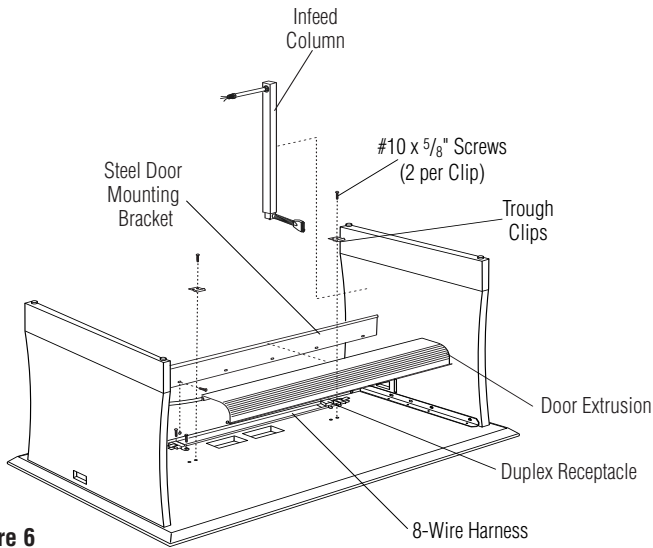

Figure 6

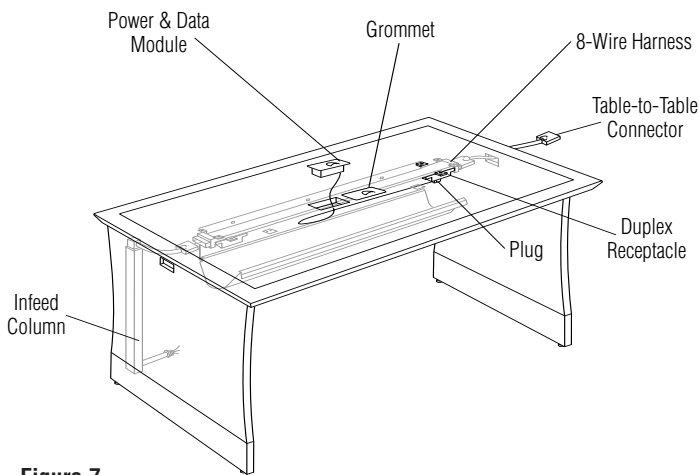

Figure 7

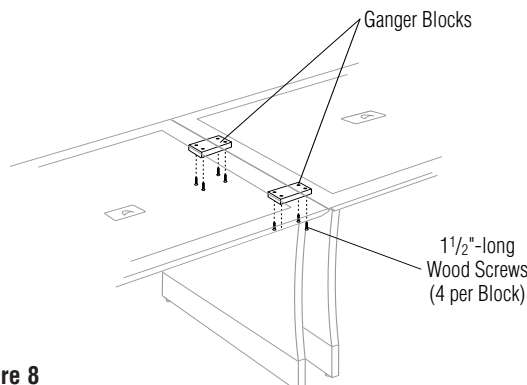

Figure 8

8. Flip table upright. Insert power and data modules. Plug cords into duplex receptacle (Figure 7).
9. For ganged and/or electrically interconnected tables, attach two wood ganger blocks with 1 1/2"-long wood screws to the underside of the table top on each end (Figure 8).

New York City Guidelines

- A. All wiring must be installed by an electrician licensed in New York City.
- B. All branch circuit wiring must be #12 AWG minimum.
- C. Each branch circuit must be fused at 15 AMP maximum with no more than 10 outlets per circuit.
- D. A service entry box must be provided with a service panel. The box size must be approximately 2.25 cubic inches for each #12 AWG wire entering the box plus 2.25 cubic inches for each #12 AWG wire leaving the box.
- E. Flexible metal liquid-tight conduit (customer supplied) from the supply source to the panel may not exceed 18 inches in length and must be hardwired at both ends, per Article 4 of the New York Electrical Code.
- F. If task lights are part of the electrified panel system, the Advisory Board submission must include a sketch showing how the task lights are installed and removed without the use of tools.

For Panel Leg Table With Single-Circuit, Multi-Circuit or New York City Infeed Boxes

Note: The combined length of the interconnected tables shall not exceed 30 feet. Do not make any connections to a power source until all steps below are followed and the electrical integrity of the finished system is inspected.

Tools Required:

- #2 Phillips screwdriver
- Power drill
- 1/8" drill bit

Hardware Included:

- 1/4" x 1/2" machine screws
- 1 1/2" wood screws

1. With table still inverted, slide the metal door hanging into the plastic door extrusion and center it on the center support brace with 1/4" x 1/2" machine screws (Figure 6). Note: plastic door extrusion will curve onto bottom side of table top.
 2. Position the door clip under the inside flange of the trough (one on each end). Mark and pre-drill holes. Fasten door clip to table top with screws supplied (2 per clip).
 3. Center the 8-wire harness on the length of the table. Mark and pre-drill holes. Attach to bottom side of table top with screws provided in the kit.
 4. Snap the plastic door extrusion into the door clip.
 5. Attach the power entry infeed column to the inside of the panel leg closest to the power source.
- Note:** only the first table in a row needs the power entry infeed column.
6. Insert the table-to-table connector into the 8-wire harness and feed through the slot in the end of the table to reach the next table in the row.
 7. Plug the optional duplex receptacle into the 8-wire harness and then attach it to the table top with 2 screws.

**You make the rules.
We make the rest.®**

Of course KI solutions work better for you. They're made for you. No one pays more attention to customer needs than we do. We don't design our furniture to win awards (even though it does). We don't rely on one-size-fits-all solutions (even though they would make our life easier). We find out what the market needs. And, we make it. The same applies to our service, distribution...everything we do. KI solutions work, because we're working for you.

KI
1330 Bellevue Street
P. O. Box 8100
Green Bay, Wisconsin 54308-8100
1-800-424-2432
www.ki.com

KI and Working for You
are registered trademarks
of Krueger International, Inc.

© 2009 KI
All Rights Reserved.
Litho in USA.
Code KI-61559R2/TMI/GT/409

