

PRODUCT SPECIFICATIONS ■

Backbone® Media Platform

April 2014

TECHNICAL SPECIFICATIONS

Enclosure

Vertical enclosure shall consist of 3/4" thick 45# particle board with exposed surfaces finished with a minimum of .030" thick high pressure laminate. Access to internal wiring shall be provided by a lockable removable door with minimum dimensions measuring 10" tall by 48" long. Ventilation is provided through openings on each end measuring a minimum 8" x 15" and covered with powder coated perforated steel panels. The table legs on the multiple table unit will be color-matched to the powder coat on the end panels.

The single table unit surface will be supported by two 1 1/2-gauge formed and welded steel supports containing leveling glides. These powder coated supports are bolted to the lower support cross members. This unit will be topped by a 1-1/8" thick 45# particle board top.

The multiple table unit spine will be supported by four 2.44" diameter casters and contain rare earth ganging magnets on two sides of the spine. These units will be topped with a 3/4" thick 45# particle board top. Mobile tables are available with three different base styles (Enlite, Synthesis, Trek). Table tops are 1-1/8" thick 45# particle board topped with a minimum .030" HPL and backed with .020" HPL backer. All mobile tables will have (8) rare earth magnets to provide ganging options on 3 sides. Tables gang to the enclosure and each other.

All tops will be finished with a minimum .030" thick high pressure laminate and banded with 2mm polypropylene edge material and routed for the quantity and size of the chosen switching hardware.

Monitor Support

Monitor support shall consist of 3/4" thick 45# particle board with exposed surfaces finished with a minimum of .030" thick high pressure laminate. Units have T-nuts to attach to both stationary and mobile units with (6) bolts.



STATEMENT OF LINE

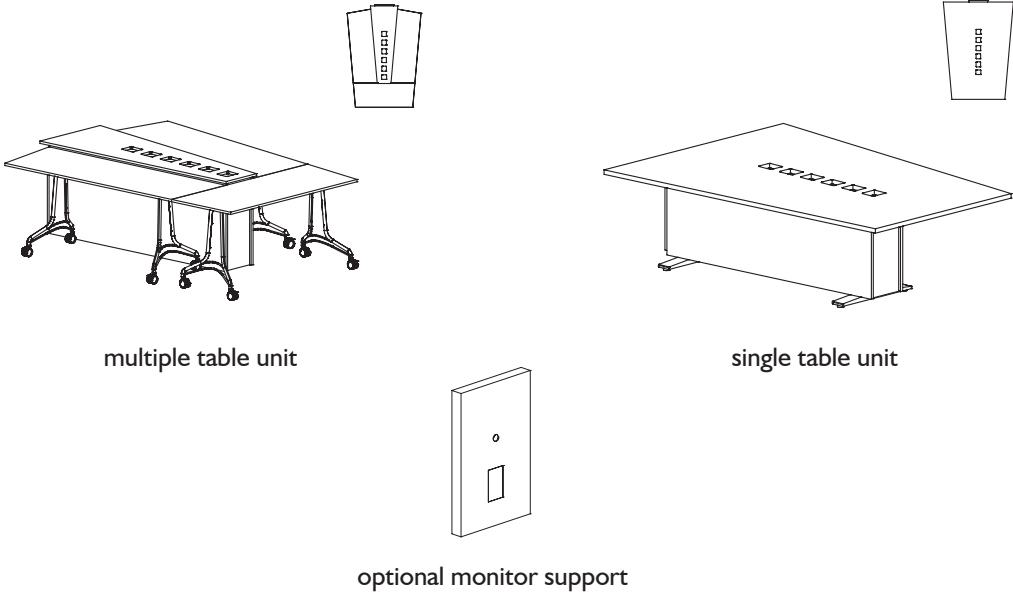

multiple table unit

single table unit

optional monitor support

DIMENSIONS — multiple table unit (in plan view)

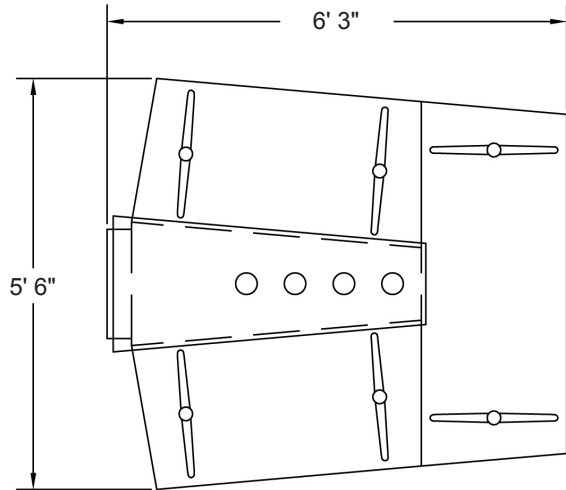

*shown with Trek table base
and FSR grommet cut-outs*

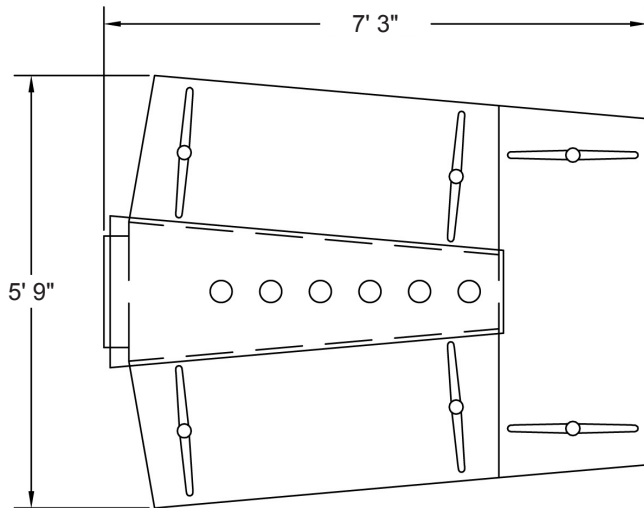

*shown with Trek table base
and FSR grommet cut-outs*

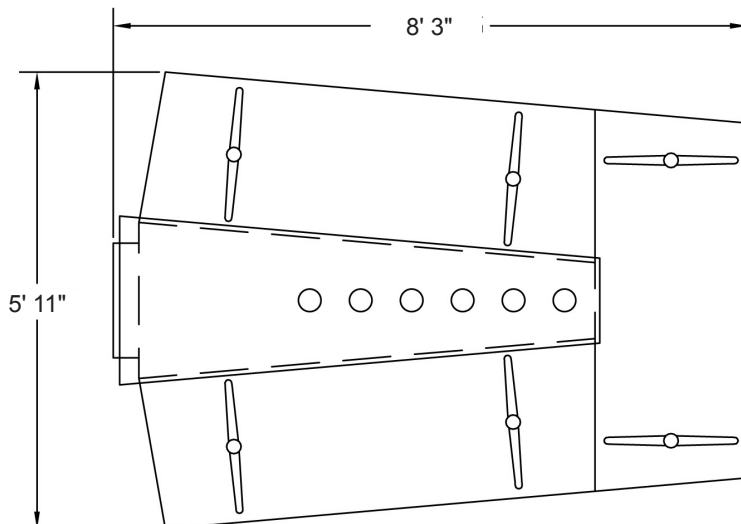

*shown with Trek table base
and FSR grommet cut-outs*

DIMENSIONS — single table unit (in plan view)

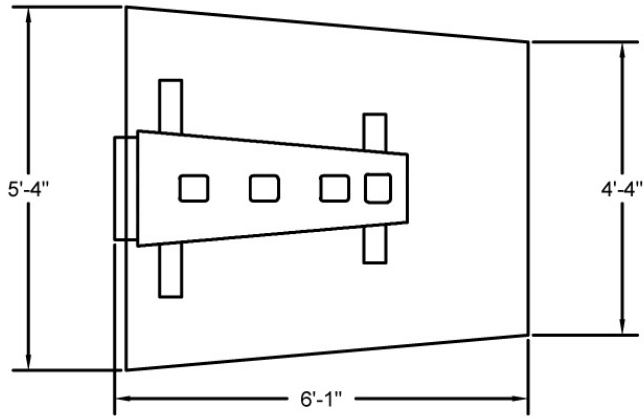

*shown with Altinex
grommet cut-outs*

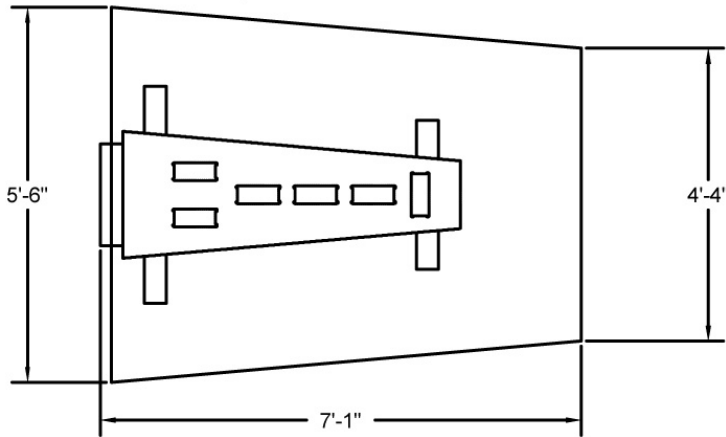

*shown with Extron
grommet cut-outs*

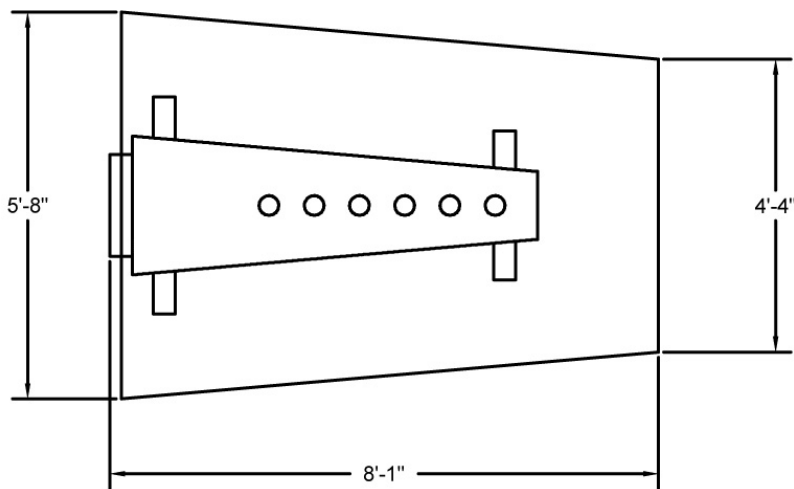

*shown with FSR
grommet cut-outs*

DIMENSIONS — grommet options (*KI creates cut-outs; customer supplies hardware*)

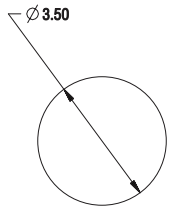

FSR (FS1)
T3, TABLE BOXES

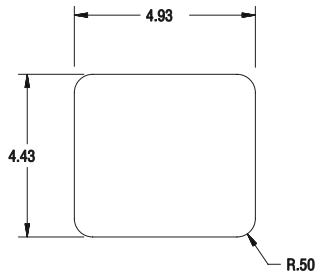

ALTINEX (AL1)
CABLE NOOK JR.

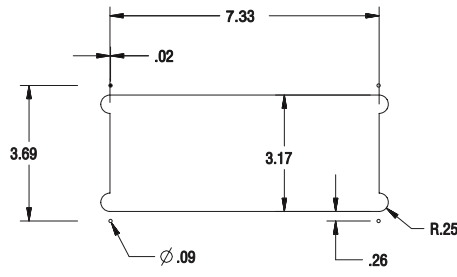

EXTRON (EX1)
CABLE CUBBY 200

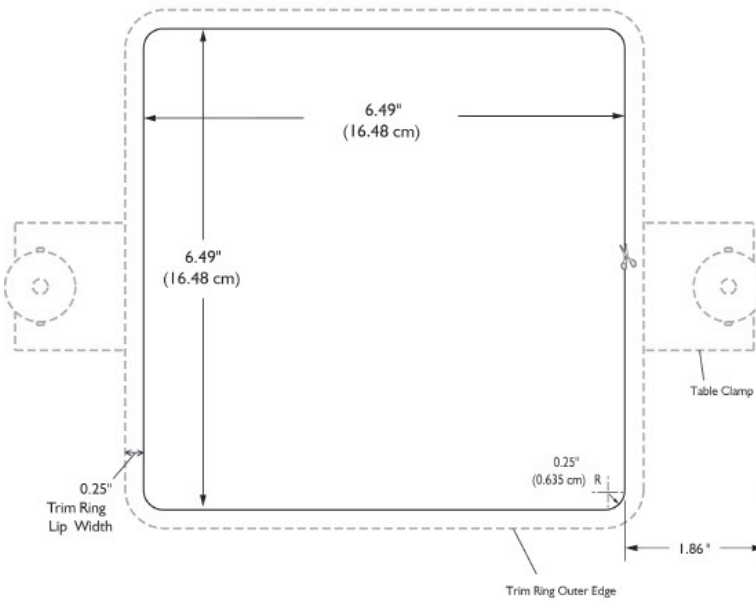

EXTRON (EX2)
Cable Cubby 600

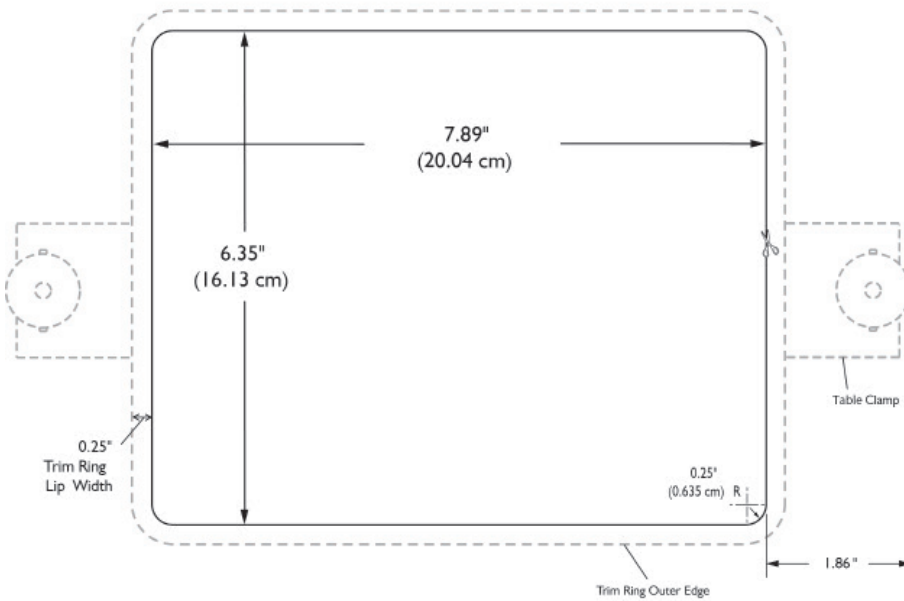

EXTRON (EX3)
Cable Cubby 800

DIMENSIONS — *grommet options (KI creates cut-outs; customer supplies hardware)*

ALTINEX

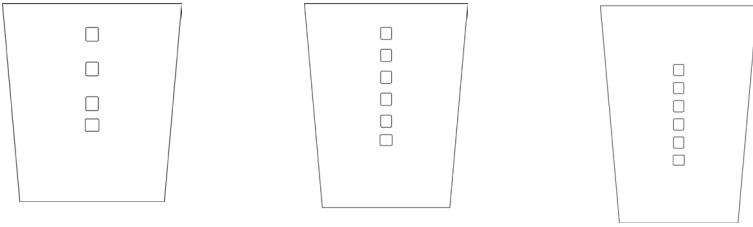

EXTRON (EX1)

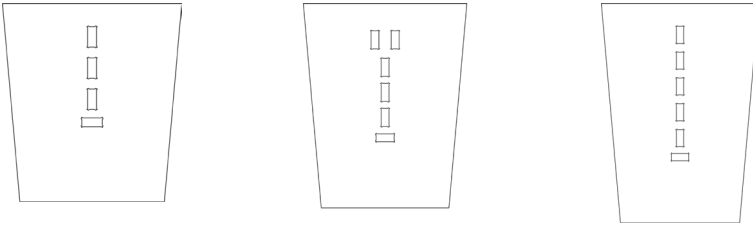

EXTRON (EX2)

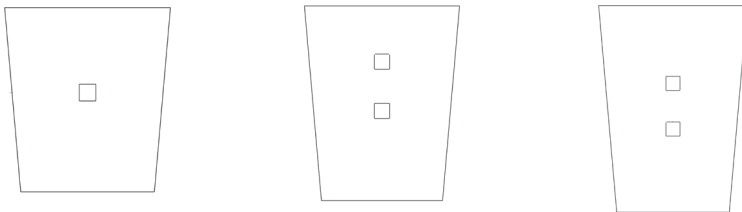

EXTRON (EX3)

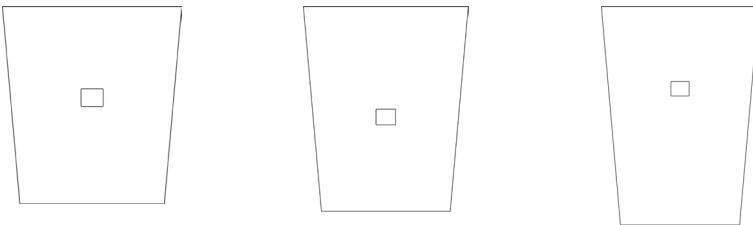

FSR

