

Assembly Instructions ■

Athens® Table

Disk Base Model AH6R6029

May 2011

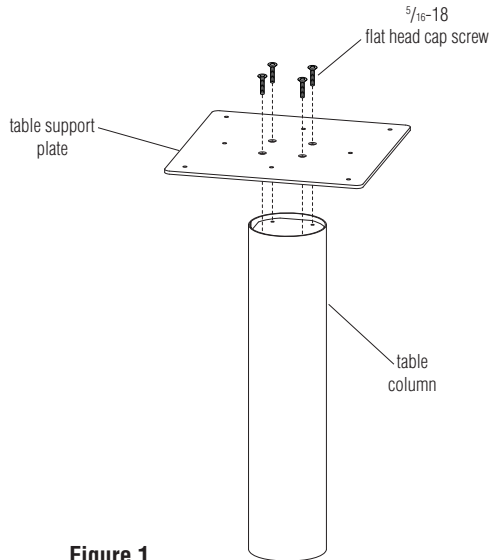

Figure 1

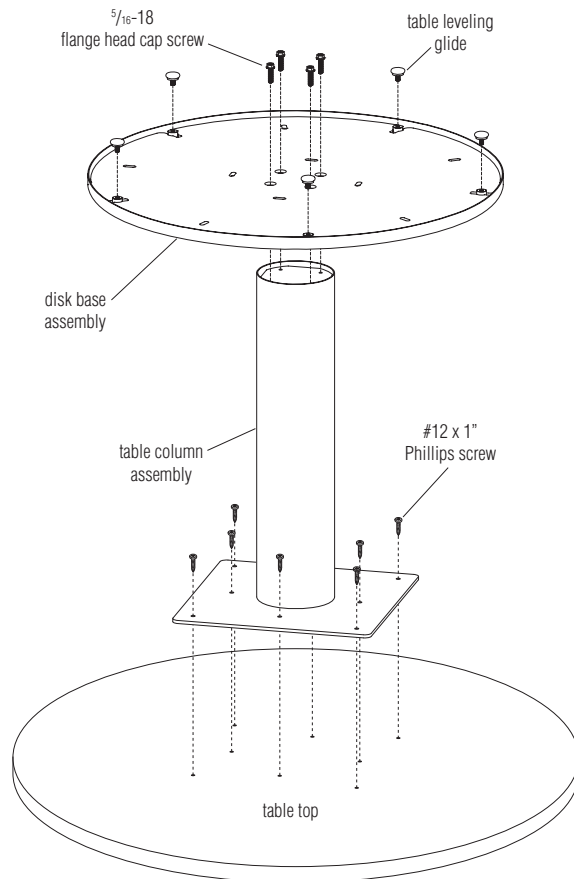
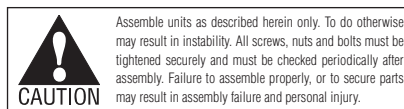

Figure 2



Tools Required:

- $\frac{3}{16}$ " hex driver
- $\frac{1}{2}$ " hex socket wrench

1. Carefully remove contents from packaging and view Figures 1 & 2 to familiarize yourself with the table base parts. If the table support plate was shipped attached to the Athens base assembly, unbolt the two before beginning assembly.
2. Position the table support plate as illustrated over the table column. Make sure the tapered, counter-sunk holes in the plate are facing up for the screw heads to nest into. Attach the plate to the column using four $\frac{5}{16}$ -18 flat head cap screws provided. Using a $\frac{3}{16}$ " hex driver, tighten screws to between 20 and 25 foot pounds of force (Figure 1).
3. Carefully flip the table column assembly over so the table support plate is down and position the disk base assembly over the table column as illustrated. Align the mounting holes in the disk with the threaded holes in the column and secure the disk base to the column using four $\frac{5}{16}$ -18 flange head cap screws provided. Using a $\frac{1}{2}$ " socket, tighten screws to between 20 and 25 foot pounds of force (Figure 2).
4. If not pre-installed, thread in five table leveling glides. Adjustment of glides may be necessary after table assembly is complete and table is set upright in its desired location.
5. Carefully set table top upside down onto a soft, protective surface. Position the table support plate of the table column assembly over the appropriate pre-drilled hole pattern in the underside of the worksurface. Secure using eight #12 x 1" Phillips pan head screws. Do not over-tighten (Figure 2).