

Repair & Replacement Instructions

KI 700 Series/E-Series/U-Series/Areus/SystemsWall Pedestals

Drawer Replacement

July 2015

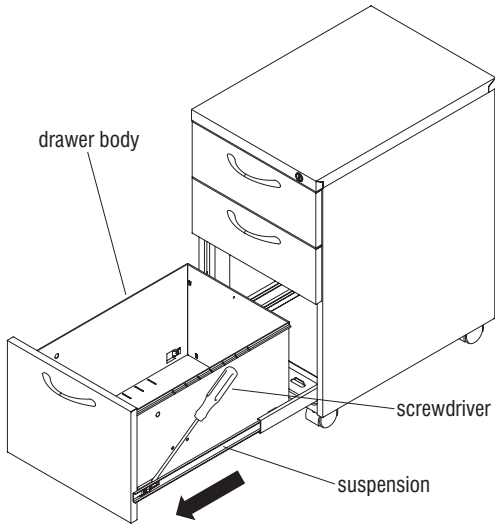

Figure 1

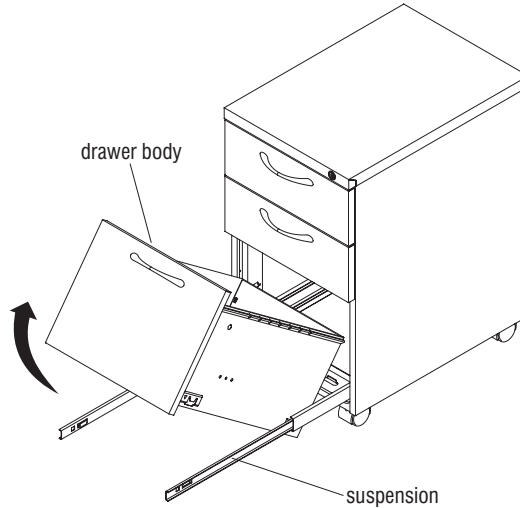

Figure 2

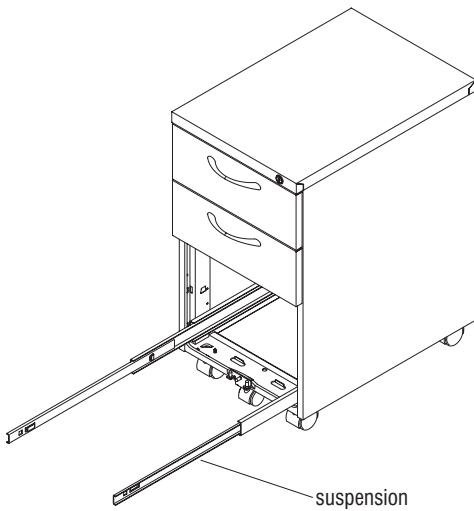

Figure 3

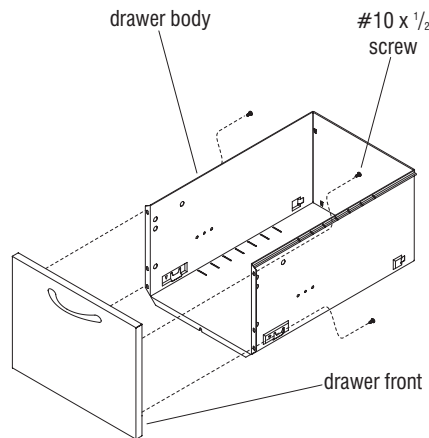

Figure 4

Drawer Removal

1. Empty all file drawer contents and pull drawer open until suspensions are fully extended.
2. Using a slot screwdriver, place the tip between the drawer body and the suspension, near the slip-connection as illustrated (Figure 1).
3. Rotate the screwdriver and pry the suspension away from the drawer body, while pressing up on the bottom of the drawer to release the front. Repeat for other side (Figure 1).
4. The drawer will now slip free from the rear connections by pulling the drawer evenly at a slight angle upwards (Figure 2).

Suspension Removal

1. Grip extended part of suspension and twist the suspension such that the top side of the suspension is being forced toward the drawer opening (Figure 3).
2. While the suspension is in the twisted position pull up.
3. To remove the back slip connection pull the suspension forward out of the cabinet.

Drawer Replacement

1. Install replacement suspensions if required.
2. Attach drawer front to drawer body using four #10 x 1/2" screws (Figure 4).
3. Fully extend each suspension out of the cabinet.
4. Slide the rear slip connection together by aligning the tab of the suspension with the corresponding slot in the drawer body. Hold suspension firmly while pushing the drawer in, making sure the slip connection is together properly.
5. If the rear slip connection is put in place correctly, the front connection tabs will align and drawer can push down into place. Secure drawer body into the front slip connection.



Assemble units as described herein only. To do otherwise may result in instability. All screws, nuts and bolts must be tightened securely and must be checked periodically after assembly. Failure to assemble properly, or to secure parts may result in assembly failure and personal injury.

