

Assembly Instructions

KI 700 Series Desk Return

August 1997

KI Pembroke
P.O. Box 580
1000 Olympic Drive
Pembroke, Ontario
K8A 6X7

TEL (613) 735-5566
FAX (613) 735-3333

Components

- 1 - Desk Return
- 2 - Modesty Panel
- 3 - End Panel
- 4 - Wire Management Channel
- 5 - Level or Step Connector

Tools Required

- Phillips Screwdriver
- 3/8" Socket/Wrench

Hardware Parts List

- (9) #20162 - #8 x 1/2" Screws
- (6) #20192 - #14 x 7/8" Screws
- (2) #20201 - #14 x 7/8 Hanger Screws
- (2) #20425 - Hex Glides

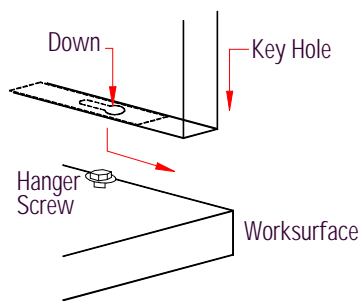
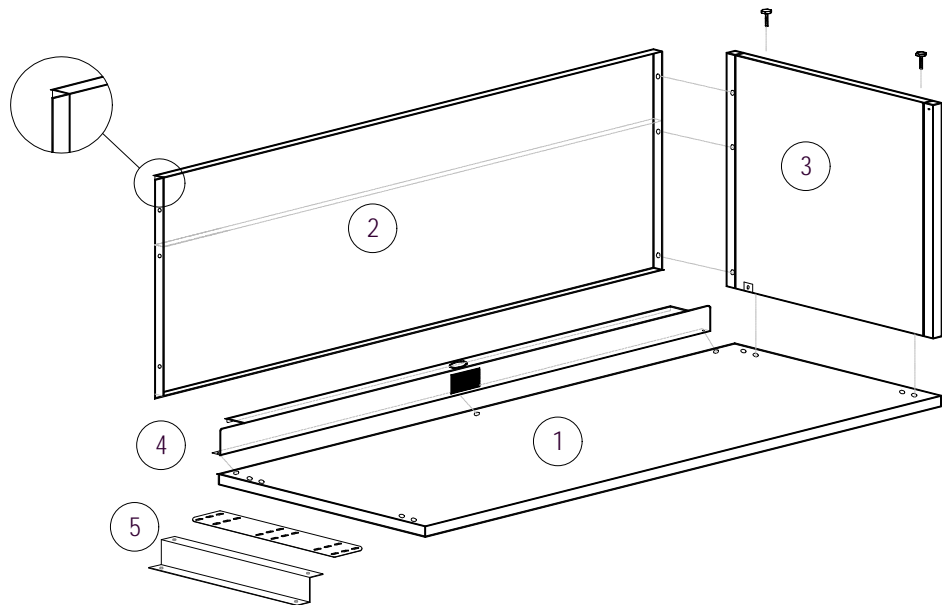

Detail A

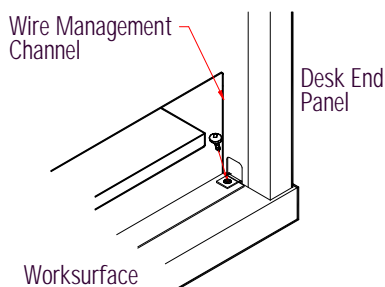

Detail B

1. To avoid scratching worksurface, place top face down on a protective surface.
 2. Insert (2) hanger screws in predrilled holes for end panels. Place end panel over hanger screws and slide into position (Detail A).
 3. Position modesty panel against end panel aligning holes with those in end panel, fasten using (2-3)* #8 x 1/2" screws.
 4. Place wire management channel on worksurface against end panel and modesty panel, product label facing inward, keeping predrilled holes aligned. Bend tab in end panel over wire management channel (Detail B). Secure wire management channel in place with (3) #8 x 1/2" screws.
 5. Screw (2) hex glides in bottom of end panel. See options on reverse.
 6. Turn right side up for final placement.
- * (2) - #8 x 1/2" screws - partial modesty panel
(3) - #8 x 1/2" screws - full modesty panel

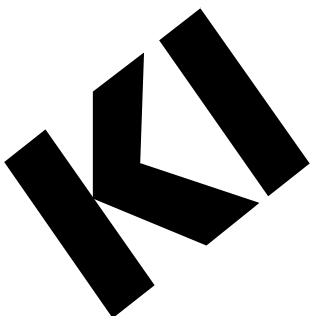

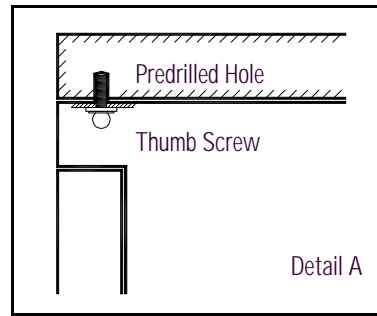
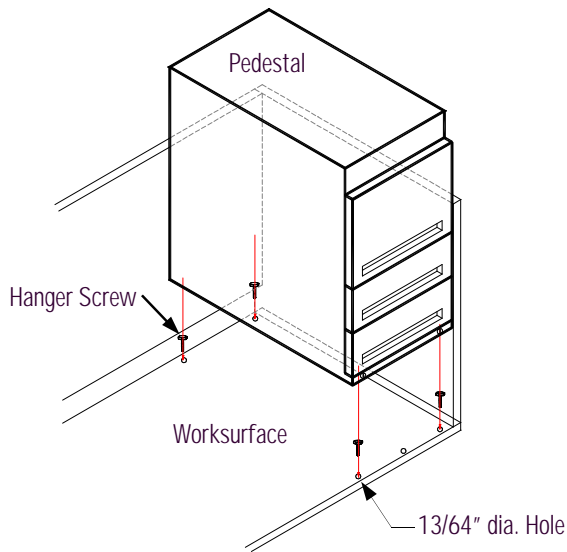

Mounting Pedestal to Worksurface

Mounting hardware included with pedestal.

1. Determine on which side the pedestal will be used.

2. Install (4) hanger screws into 13/64" dia. holes. CAUTION: Do not over tighten.
3. Position back of pedestal to engage with back hanger screws and slide backward enough to allow front key slots to engage. Continue to push backward until full engagement is reached.
4. Open top drawer, install thumb screw through pedestal top and into predrilled hole in the worksurface. Thumb screw must be installed to lock pedestal to the worksurface (Detail A).

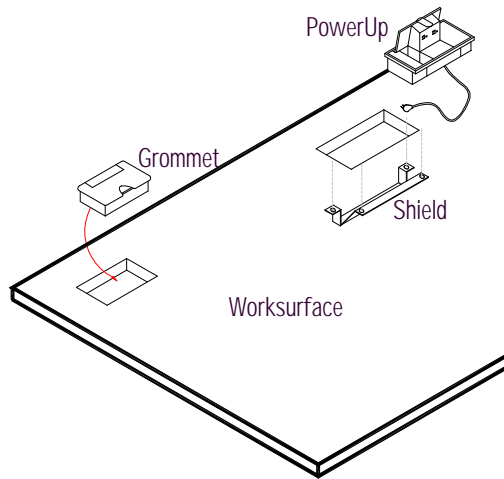

Installing Grommets & PowerUp

Hardware Parts List

(4) #20162 - #8 x 1/2" Screws

1. Press worksurface grommets into wireway holes in worksurface.

PowerUp Only

2. Route cord through the hole in the worksurface. Snap the PowerUp option into the hole in worksurface.
3. Install PowerUp shield to underside of worksurface using (4) #8 x 1/2" screws.



CAUTION

Assemble units as described herein only. To do otherwise may result in instability. All screws, nuts and bolts must be tightened securely and must be checked periodically after assembly. Failure to assemble properly, or to secure parts may result in assembly failure and injury.