

Assembly Instructions

KI 700 Series P-Shape Desk

August 1997

KI Pembroke
P.O. Box 580
1000 Olympic Drive
Pembroke, Ontario
K8A 6X7

TEL (613) 735-5566
FAX (613) 735-3333

Components

- 1 - P-Shape Worksurface
- 2 - End Panel
- 3 - D/P Support Panel
- 4 - Support Column

Tools Required

- Phillips Screwdriver
- 3/8" Socket/Wrench

Hardware Parts List

- (1) #13.10.0185 - Levelling Glide
- (1) #13.10.0186 - Carpet Gripper

Hardware Parts List Cont'd

- (1) #20051 - 5/16"-18 x 1/2" Hex Bolt
- (2) #20162 - #8 x 1/2" Screws
- (8) #20192 - #14 x 7/8" Screws
- (2) #20201 - #14 x 7/8" Hanger Screws
- (1) #20203 - 10-16 x 1/2" Self Drilling
- (3) #20425 - Hex Glides
- (1) #45428 - Mount Bracket

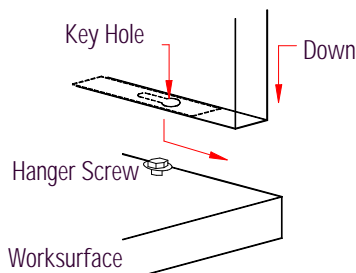
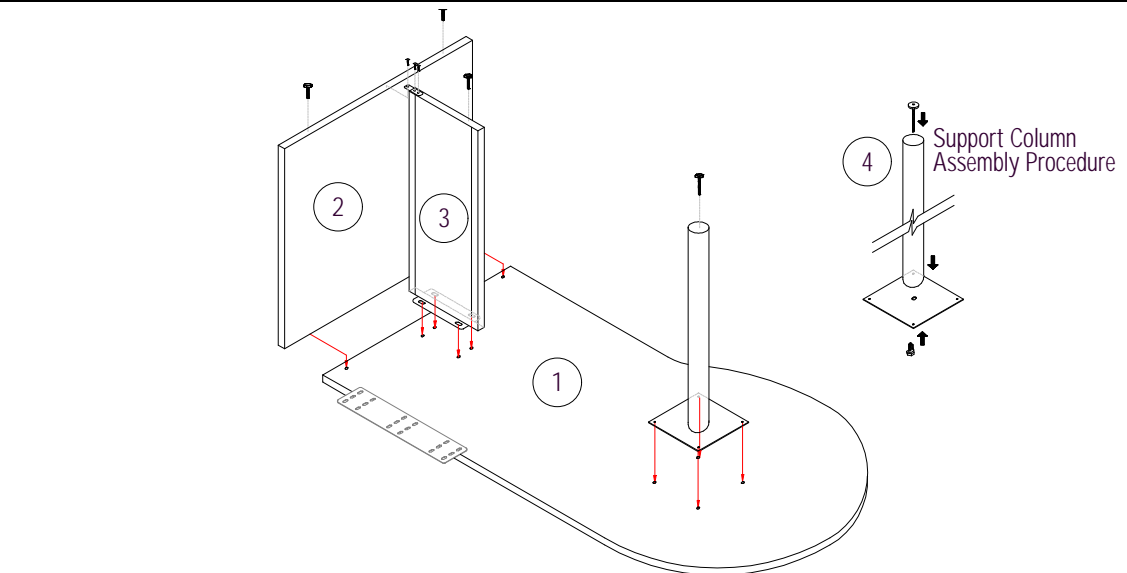

Detail A

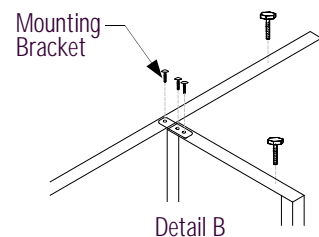

Detail B

1. To avoid scratching worksurface, place top face down on a protective surface.
2. Insert (2) hanger screws in predrilled holes for end panel. Place end panel over hanger screws and slide into position (Detail A).
3. Position D/P support panel flange side down. Secure in place with (4) #14 x 7/8" screws.
4. Place mount bracket on D/P support panel and end panel (Detail B). Insert (2) #8 x 1/2" screws into D/P support panel and (1) 10-16 x 1/2" self drilling screw into end panel.
5. To assemble support column place plate on top of column. Secure in place with (1) 5/16"-18 x 1/2" hex bolt. Screw levelling glide into bottom of column.
6. Position support column over holes in P-Shape Desk. Drive (4) #14 x 7/8" screws in to secure support column to top.
7. If attaching bridge/return, align level connector (shipped with bridge/return) with predrilled holes in worksurface. Use (2) #14 x 7/8" screws to attach level connector to worksurface.
8. Install the (3) hex glides into bottom of the end panel and support panel.



CAUTION

Assemble units as described herein only. To do otherwise may result in instability. All screws, nuts and bolts must be tightened securely and must be checked periodically after assembly. Failure to assemble properly, or to secure parts may result in assembly failure and injury.

