

HAWORTH®

ENCLOSE® | INSIGHT









# CONTENTS

## BUSINESS NEEDS

4

## DESIGN

Perspective

6

Storefront

7

Space Division

8

Private Office

9

Collaborative Spaces

10

## TECHNICAL GUIDE

11

Product Logic

12

Entrance Systems

14

Panels

26

Storefront

32

Transitions

38

Dimensional Logic

44

Stack-On Panels

46

Technology

47

## FINISHES

48

Frames + Panels

49





## BUSINESS NEEDS

The nature of work is constantly changing—a fact that organizations deal with every day. External influences are at play around us, creating a domino effect that generates business challenges. Technology is progressing so fast it's difficult to stay ahead. These advances, in turn, determine where and how people work, and influence business drivers, organizational culture, and workplace design.

As your organizational needs change, your space should evolve as well. Haworth architectural walls help make spaces flexible, responsive, cost-efficient, and beautiful. For the past three decades, we've been using architectural walls to help organizations transform their space and maximize their inventory so they can get back to business quickly and economically.



**BUSINESS NEEDS**





Enclose is an architectural wall system with all the fluidity of furniture and all the presence of permanent walls. A clean, simple design provides a timeless look, while a 10-year warranty ensures the performance will last just as long. Part of Haworth's Integrated Palette™, Enclose walls are sustainably designed to anticipate change, and moveable panels offer endless adaptation.

Haworth offers pre-assembled unitized panels that are pre-wired and inspected so you can stay on schedule. Easy-to-install factory assembled panels offer structural stability. Because they can stand freely, you can even set them up before the base building is ready. With modular power installed in the wall, unitized panels are just like furniture—there's no need for electrical work to be done in the field. Plug-and-play power/data integration—both vertical and horizontal—provide flexibility while saving time and costs. And they work well with underfloor air applications.

Customers with multiple ceiling heights can maximize use of inventory with a kit of parts—including stackable panels—for more flexibility. Haworth architectural walls are specified to the millimeter, offering design freedom within your space. It all adds up to a performance that's so versatile, it surpasses conventional construction.



**DESIGN**  
STOREFRONT

Enclose Frameless Glass lets you combine the elegant simplicity of floor-to-ceiling glass walls with the flexibility of a reconfigurable wall system. Designed with a low base profile, it uses the same infrastructure as other Enclose walls, enabling hard-wall-to-hard-wall integration or effortless connection to dividing walls.

Design endless runs with straight lines, faceted curves, or variable angle corners, creating a refined storefront that elevates your environment.





**DESIGN**

SPACE DIVISION

Enclose walls are ideal for delineating space into different sections without creating a full office. Imagine partitions within an open plan, a reception area wall welcoming visitors with your logo, or a wall shielding a break area or waiting room.

A seamless connection to walls, floors, and ceilings gives them the presence of permanent walls, but the adaptable system of Enclose allows you to move or update them whenever needs arise.





**DESIGN**

PRIVATE OFFICE

The number, size, and location of private offices can change without warning, but Enclose walls can be reconfigured quickly, easily, and cost effectively to keep your environment in sync with personnel changes. Flexibility is carried to the inside of the office.

Engineered with vertical slotted standards, Enclose walls give you the ability to mount furniture, hang shelves and accessories, and incorporate writable or magnetic surfaces. Locking doors and acoustic privacy panels with an impressive STC rating keep confidential matters secure, and optional sliding doors can eliminate wasted space.





**DESIGN**

COLLABORATIVE SPACES

From informal conversation pits to strategy rooms to formal meeting rooms, Enclose can help you create appealing and functional spaces for any type of collaboration. Acoustic panels contain the noise and activity to one room, and opaque, frosted, or transparent panels let you choose the degree of visual privacy you need.

Enclose walls are designed with removeable tiles for easy access to the interior cavity. Make electric, voice, and data changes as needed, whether you utilize a quick-connect or hard-wired system. Technology hardware can be flush or proud mounted to the tile. With Haworth's extensive material options and furniture components, you can design your space to meet the technology and acoustic performance required today and in the future.





# TECHNICAL GUIDE

<b>PRODUCT LOGIC</b>	<b>12</b>	<b>PANELS</b>	<b>26</b>	<b>TRANSITIONS</b>	<b>38</b>	<b>DIMENSIONAL LOGIC</b>	<b>44</b>
Fundamentals	12	Glass	26	2-Way	38	<b>STACK-ON PANELS</b>	<b>46</b>
Doors + Panels	13	Solid	28	3-Way	40	<b>TECHNOLOGY</b>	<b>47</b>
<b>ENTRANCE SYSTEMS</b>	<b>14</b>	Combination	30	Fly-By + 4-Way	42		
Swing Doors	14	<b>STOREFRONT</b>	<b>32</b>	Starters + End of Runs	43		
Sliding Doors	18	Storefront Glazing Options	32				
Double Glazed Doors	22	Frameless Glass	33				
		Frameless Glass 2 Channel	35				

Enclose offers a fully adaptable kit of parts with consistent dimensions, connections, and finishes that are easy to integrate with architectural products. Explore the options to create versatile, reconfigurable solutions for any application, from private to team spaces.

The standard four-inch frame of Enclose walls seals and aligns perfectly with base building architecture. These refined connections create a seamless application. Components are manufactured to the exact height and width that complement your building module, allowing for an interior architectural wall that fits precisely. Choose from a range of architectural details for a tailored solution.



TECHNICAL GUIDE

PRODUCT LOGIC: FUNDAMENTALS

UNITIZED WALL SYSTEM



CEILING CONNECTION

- Locks the panel system to the building ceiling grid or finished ceiling
- Non-marring
- Re-locatable/reusable



INTEGRATED FLOOR CONNECTION

- Adjustable floor track available with either a non-marring carpet gripper or non-marring smooth shoe for hard floor applications



REVEAL CONNECTORS

- Clean, consistent reveals
- Available in multiple colors



SIDE CUTTABLE PANELS

- Offers flexibility in width
- Custom scribed to building detail on site
- Available in solid panels only



TOP CUTTABLE PANELS

- Offers custom fit to irregular ceiling conditions
- Custom scribed to building detail on site
- Available in solid and glass/solid combination panels



REMOVEABLE TILES

- Specify monolithic or segmented
- Ships assembled
- Allows for easy refresh

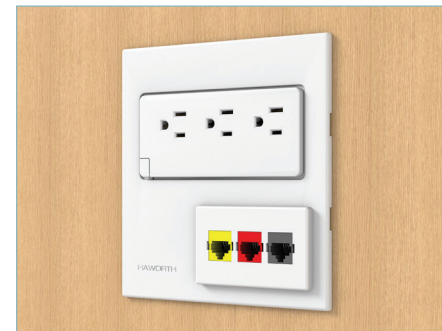

TECHNOLOGY INTEGRATION

- Power base (plug + play)
- Conventional power
- Can accommodate low voltage, data, USB



**TECHNICAL GUIDE**

PRODUCT LOGIC: DOORS + PANELS

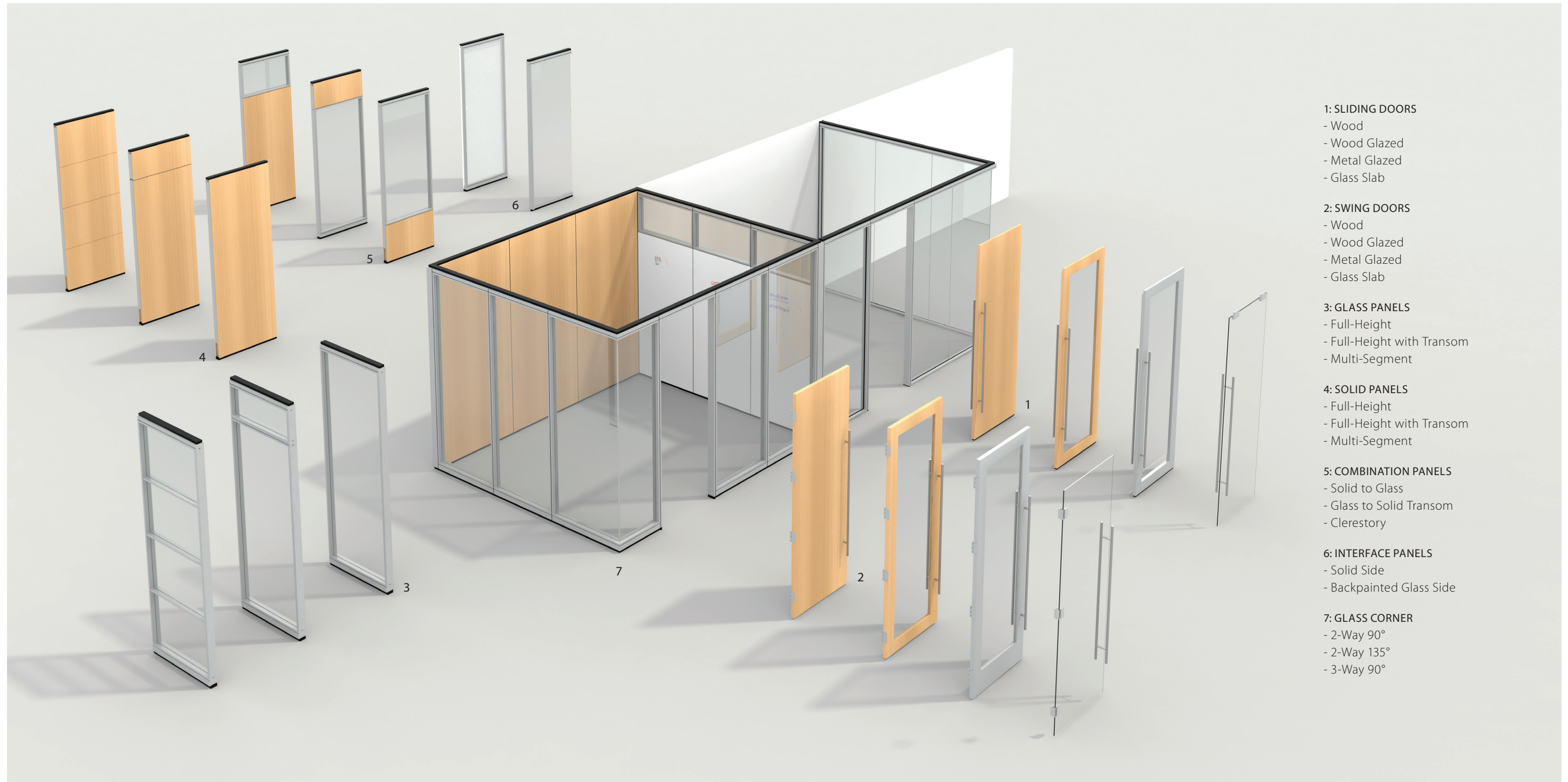

**1: SLIDING DOORS**

- Wood
- Wood Glazed
- Metal Glazed
- Glass Slab

**2: SWING DOORS**

- Wood
- Wood Glazed
- Metal Glazed
- Glass Slab

**3: GLASS PANELS**

- Full-Height
- Full-Height with Transom
- Multi-Segment

**4: SOLID PANELS**

- Full-Height
- Full-Height with Transom
- Multi-Segment

**5: COMBINATION PANELS**

- Solid to Glass
- Glass to Solid Transom
- Clerestory

**6: INTERFACE PANELS**

- Solid Side
- Backpainted Glass Side

**7: GLASS CORNER**

- 2-Way 90°
- 2-Way 135°
- 3-Way 90°



**TECHNICAL GUIDE**

**ENTRANCE SYSTEMS: SWING DOORS**

Enclose entrance systems offer coordinated building access control to any kind of building environment. They're designed for height variation and can be used in full height door applications—no more transoms required. They accommodate commercial standard doors with industry standard door hardware. Adjustable door bottoms minimize gaps under doors. Combined with a continuous sound seal, Enclose entrance systems offer optimal acoustical performance.

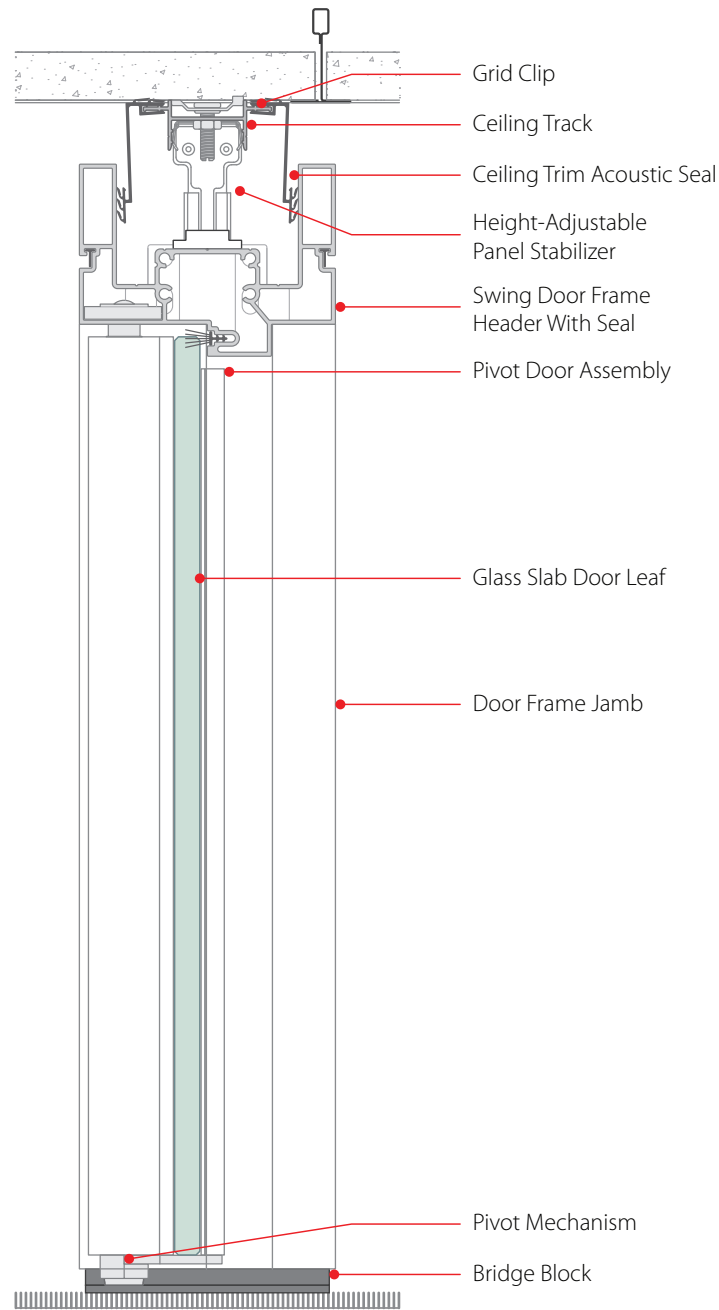

VERTICAL SECTION

- Integrated frame brush seals
- Adjustable plinth available for certain door types

**FEATURES**

- Swing doors are available as either pivot hinge or butt hinge
- Full-height door up to 10 feet (3048 mm) without a transom for improved aesthetics and lower cost across an entire front wall
- Lower cost advantage of factory assembled frames and doors, including electric strike options
- Adjustable door bottom (plinth) provides maximum adjustability while minimizing gap beneath wood and metal butt-hinge doors
- Door closers (wood and metal only)
- Wood and metal doors are 1 3/4" (44 mm) thick, accommodating industry standard hardware
- Acoustic choices in door leaf types to meet workspace privacy requirements
- Single and double doors available with no structural support required above the door while maintaining the non-marring attachment to base building

**SIZES | DIMENSIONS**

Frame Width: SINGLE: 40" – 48" (1016 mm – 1219 mm)\*  
 DOUBLE: > 48" – 96" (1219 mm – 2438 mm)\*  
 \* Frame widths are slightly larger than the actual leaf size  
 Frame Height: Up to 120" (3048 mm) for full-height door; can add transom above up to 144" (3658 mm) overall height  
 Glass Thickness (Glass Slab Door): 1/2" (12 mm) tempered  
 Glass Thickness (Glass Inset): 1/4" – 3/8" (6 mm – 10 mm) tempered or laminated glass

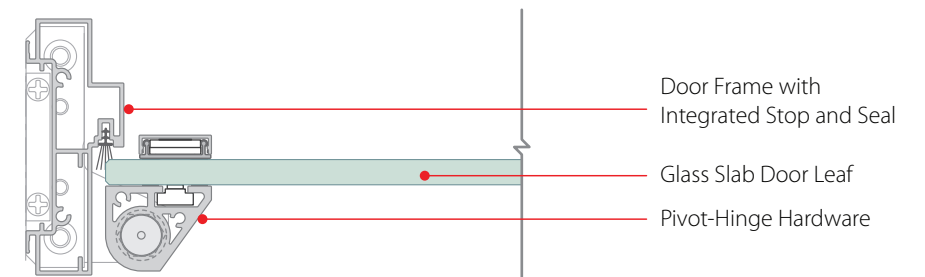

HORIZONTAL SECTION

- Pivot hinge shown (40" maximum leaf width)
- Butt hinge available



**TECHNICAL GUIDE**

ENTRANCE SYSTEMS: SWING DOOR LEAVES + FRAMES

**DOOR LEAF OPTIONS**



GLASS SLAB, PIVOT HINGE



GLASS SLAB, BUTT HINGE



METAL GLAZED, BUTT HINGE



WOOD GLAZED, BUTT HINGE



WOOD, BUTT HINGE

**DOOR LEAF PLINTH DETAILS**



WOOD OR METAL DOORS

- Door leaf plinths are available options on wood and wood glazed door leaves, and come standard on metal glazed door leaves.

**ARCHITECTURAL ELEVATIONS**



FULL HEIGHT

- Archway (no door) ceiling heights available up to 126" (3200 mm)  
 - Butt-hinge and pivot-hinge door ceiling heights available up to 120" (3048 mm)



GLASS TRANSOM

- Ceiling heights available up to 144" (3658 mm)

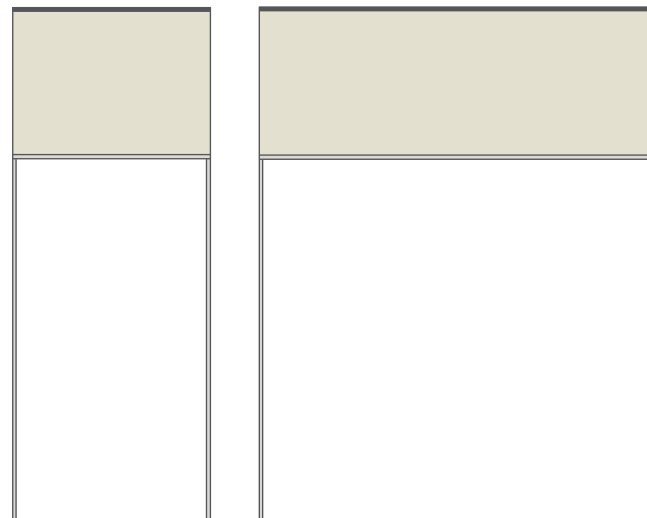

SOLID TRANSOM

- Ceiling heights available up to 144" (3658 mm)



**TECHNICAL GUIDE**

ENTRANCE SYSTEMS: SWING DOOR HARDWARE

**LOCKS + PULLS**



**CYLINDRICAL**

- Non-handed
- Cost effective



**MORTISE**

- Greater design choices
- Wide range of options



**GLASS SLAB MORTISE LOCK**

- Allows lever lockset functionality on glass slab doors
- Available in two lever styles

MANUFACTURER	WOOD + METAL		GLASS SLAB	
	BUTT HINGE		BUTT HINGE	PIVOT HINGE
	CYLINDRICAL	MORTISE	MORTISE	MORTISE
Schlage	X	X		
Sargent	X	X		
Corbin Russwin	X	X		
Yale	X	X		
Best	X	X		
FSB		X	X	X



**D PULL**

- Clean rectilinear design
- 12" (305 mm) on center



**TUBULAR PULL**

- 1" (25 mm) diameter pull
- 12" (305 mm) on center, 17" (432 mm) overall



**ARCHITECTURAL PULL**

- Longer pulls in various lengths: 18"– 84" (457 mm – 2134 mm)



**TECHNICAL GUIDE**

ENTRANCE SYSTEMS: SWING DOOR DETAILS

**HINGE OPTIONS**

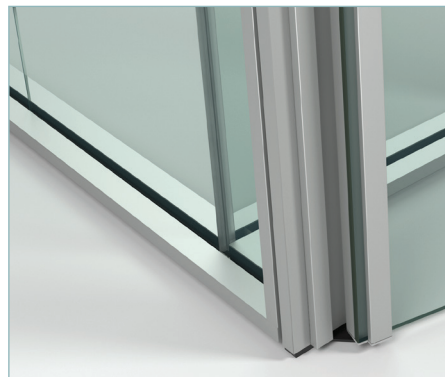

**GLASS SLAB, PIVOT HINGE**

- Continuous, full-length pivot hinge
- Color matched to door frame

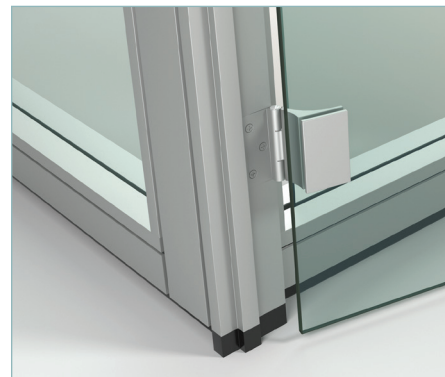

**GLASS SLAB, BUTT HINGE**

- Butt hinge functionality with glass slab aesthetic
- Color matched to door frame



**WOOD OR METAL, BUTT HINGE**

- Ball bearing hinge shown
- Electrical strike option can accommodate keyless entry

**DOOR FRAME PLINTH DETAIL**

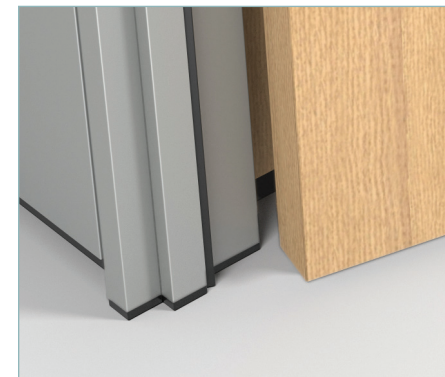

**FRAMELESS GLASS**

- With this door frame, the *jamb* is cut to height in the field and secured to the floor with the bridge block, allowing for consistent floor reveals—regardless of floor run out.

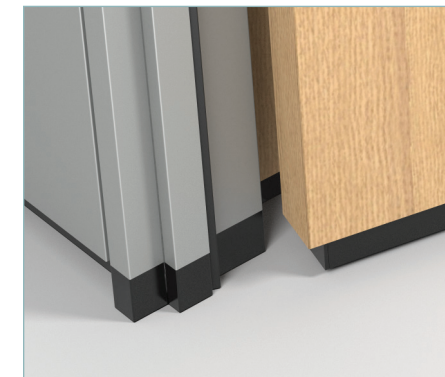

**FRAMED GLASS**

- With this door frame, the *frame plinth cap* is cut to height in the field, allowing for factory made door frames—regardless of floor run out.

**ACCESSORIES**



**DOOR STOP**

- Floor mount shown
- Panel mount available on select door

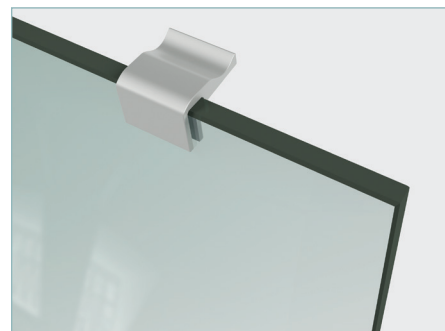

**ROLLER CATCH**

- Glass slab shown, available on wood and metal
- Closet doors
- Non-locking doors with pulls



**ELECTRIC STRIKE**

- Factory installed in door frame
- Requires field coordination of electrical hook-up



**CLOSURES + AUTOMATED OPENERS**

- Surface-mounted shown
- Can accommodate concealed closers and auto openers



**TECHNICAL GUIDE**

ENTRANCE SYSTEMS: SLIDING DOORS

Sliding doors help reduce private office footprints by eliminating swing door space on the floorplate. Vertical loads from sliding doors are supported by the adjacent wall system; no extra costs are required for structural modifications—a unique proposition for butt-jointed glass fronts. Combined with a continuous sound seal, our entrance systems offer optimal acoustical performance.

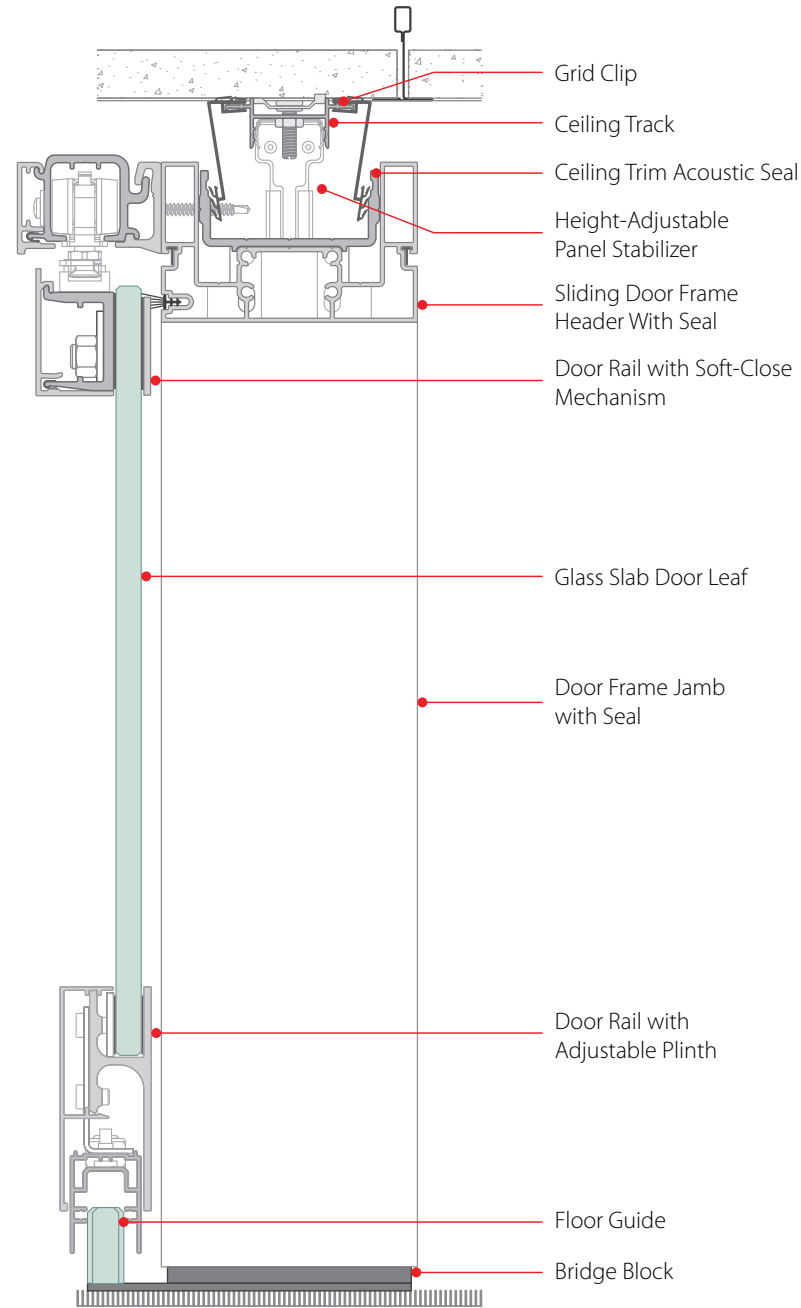

VERTICAL SECTION

- Integrated frame acoustic seals
- Optional adjustable plinth base for frameless glass slab doors

**FEATURES**

- Soft-close option for improved sliding door operation
- Single-action egress hardware to support specific codes
- Full-height door up to 10 feet (3048 mm) without a transom for improved aesthetics and lower cost across an entire office front
- Adjustable door bottom plinth provides maximum adjustability while minimizing gap beneath sliding doors
- Wood and metal doors are 1 3/4" (44 mm) thick, accommodating industry standard hardware
- Acoustic choices in door leaf types to meet workspace privacy requirements
- Single and double doors available with no structural support required above the door while maintaining the non-marring attachment to base building

**SIZES | DIMENSIONS**

Frame Width: SINGLE: 40" – 48" (1016 mm – 1219 mm)\*  
 DOUBLE: > 48" – 96" (1219 mm – 2438 mm)\*

\* Frame widths are slightly larger than the actual leaf size

Frame Height: Up to 120" (3048 mm) for full-height door, can add transom above up to 144" (3658 mm) overall height

Glass Thickness (Glass Slab Door): 3/8" (10 mm) tempered

Glass Thickness (Glass Inset): 1/4" – 3/8" (6 mm – 10 mm) tempered or laminated

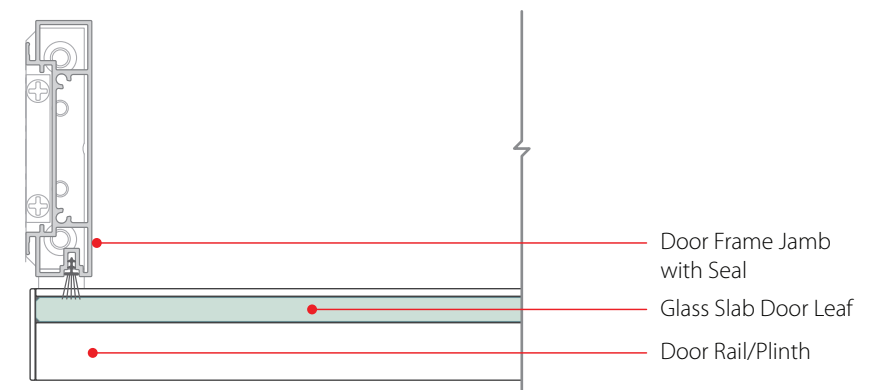

HORIZONTAL SECTION

- Base mounted guides and door stop
- Soft-close hardware optional



**TECHNICAL GUIDE**

ENTRANCE SYSTEMS: SLIDING DOOR LEAVES + FRAMES

**DOOR LEAF OPTIONS**



GLASS SLAB, SOFT-CLOSE



GLASS SLAB, WITHOUT SOFT-CLOSE



METAL GLAZED



WOOD GLAZED



WOOD

**PLINTH DETAILS**



GLASS SLAB DOOR PLINTH

- Frameless glass slab sliding doors available with optional plinth
- All other leaf types come with standard integrated plinth

**ARCHITECTURAL ELEVATIONS**



FULL-HEIGHT

- Archway (no door) ceiling heights available up to 126" (3200 mm)
- Butt-hinge and pivot-hinge door ceiling heights available up to 120" (3048 mm)

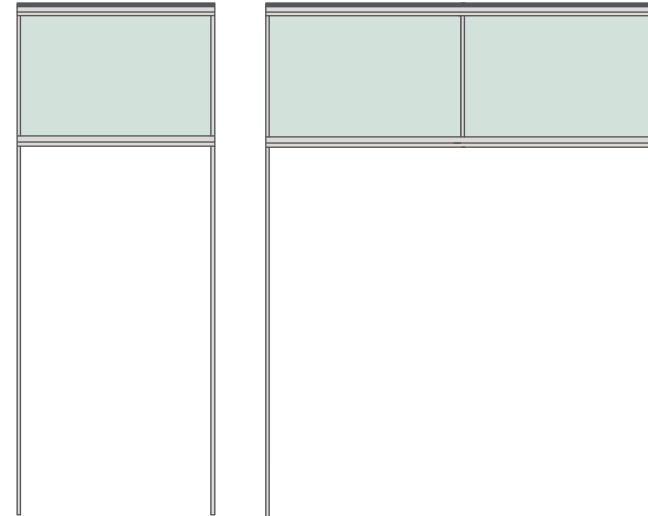

GLASS TRANSOM

- Ceiling heights available up to 144" (3658 mm)
- Cannot be used with frameless glass sliding doors



SOLID TRANSOM

- Ceiling heights available up to 144" (3658 mm)
- Cannot be used with frameless glass sliding doors



**TECHNICAL GUIDE**

ENTRANCE SYSTEMS: SLIDING DOOR HARDWARE

**LOCKS + PULLS**



**PULL + MORTISE LOCK**

- Locking capability for doors with pull
- Available on wood and metal leaves only



**SINGLE ACTION EGRESS, WOOD + METAL**

- Available on single doors only



**SINGLE ACTION EGRESS, GLASS SLAB**

- Supports specific accessibility requirements
- Patch housing matches door frame

	WOOD + METAL	GLASS SLAB
Adams Rite with Pull	X	X
Single Action Egress	X	X

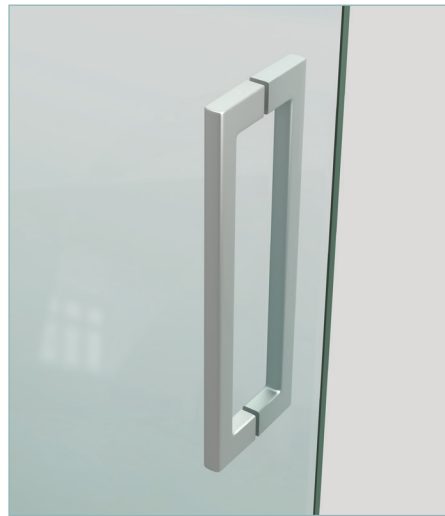

**D PULL**

- Clean rectilinear design
- 12" (305 mm) on center



**TUBULAR PULL**

- 1" diameter pull
- 12" (305 mm) on center, 17" (432 mm) overall



**ARCHITECTURAL PULL**

- Longer pulls in various lengths: 18"– 84" (457 mm – 2134 mm)



**TECHNICAL GUIDE**

SLIDING DOOR TRACK OPTIONS

**OPERATING HARDWARE OPTIONS**

---

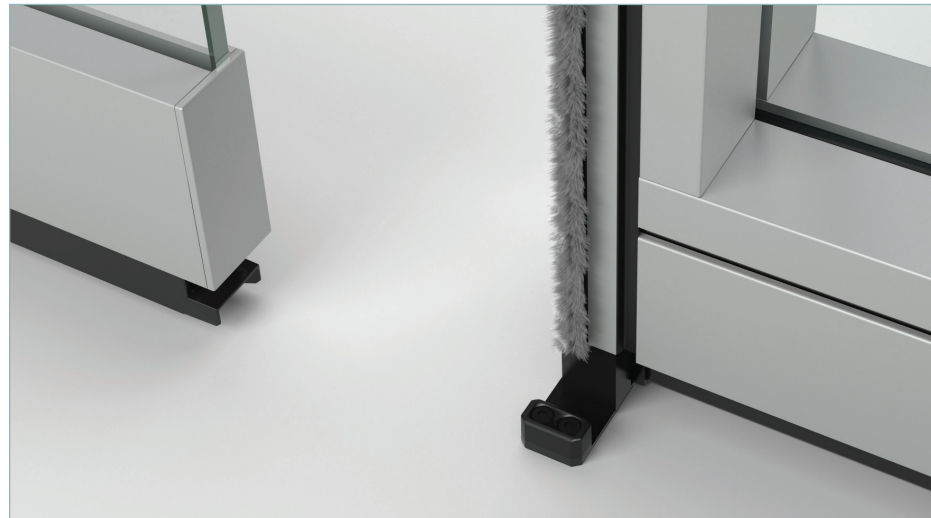

GLASS SLAB PLINTH OPTION



SOFT-CLOSE DETAIL



GLASS SLAB SLIDING PATCH DETAIL



**TECHNICAL GUIDE**

DOUBLE GLAZED SWING DOORS

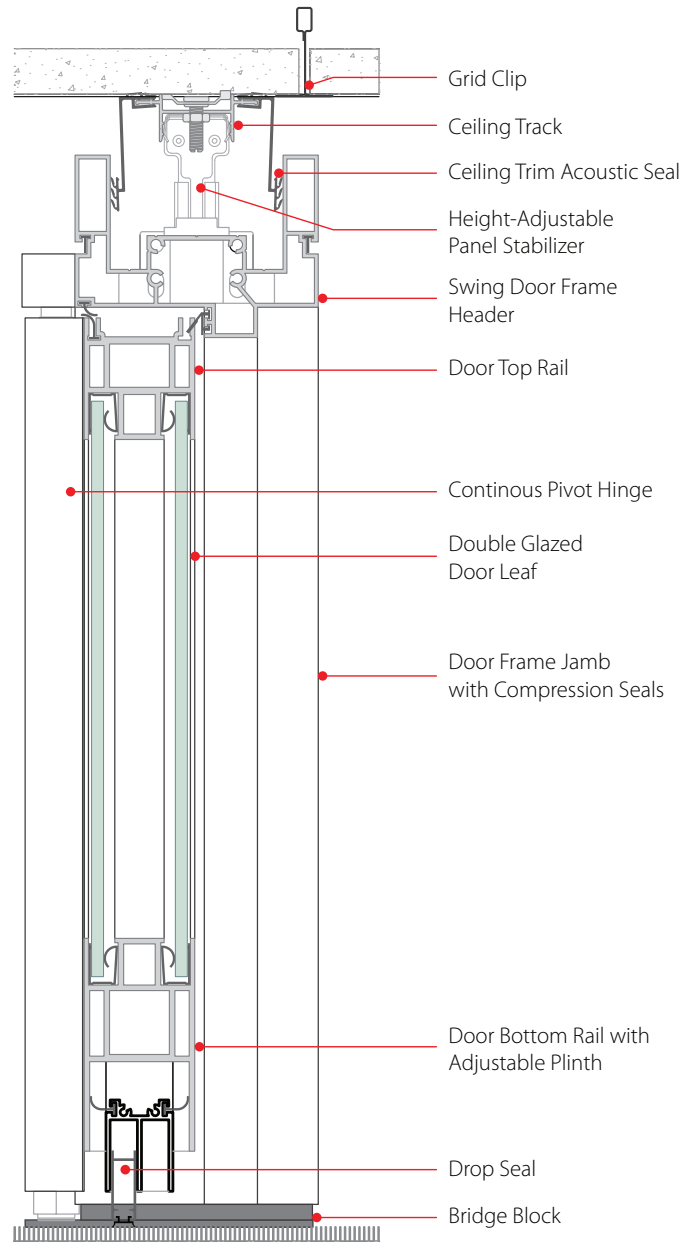

**VERTICAL SECTION**

- Integrated compression seals
- Adjustable plinth with automatic drop seal

**FEATURES**

- Double glazed swing doors available with a continuous pivot hinge
- Full-height door—up to 10 feet (3048 mm) without a transom—for improved aesthetics and lower cost across an entire wall front
- Lower cost advantage of factory assembled frames and doors, including electric strike options
- Adjustable door bottom (plinth) provides maximum adaptability and houses an integrated automatic drop seal
- Enhanced double compression seals to reduce incidental sound transmission at flanking paths
- Single and double swing doors available with no structural support required above door while maintaining the non-marring attachment to base building

**SIZES | DIMENSIONS**

**Frame Width:**  
 SINGLE: 24" – 48" (610 mm – 1219 mm)\*  
 DOUBLE: Over 48" – 96" (1219 mm – 2438 mm)\*  
 \* Frame widths are slightly larger than the actual leaf size.

**Frame Height:**  
 - Up to 120" (3048 mm) for full-height door  
 - Can add stack-ons above for up to 144" (3658 mm) overall height when adjacent to unitized Enclose walls

**Glass Thickness (Glass Inset):** 3/16" (5mm) tempered

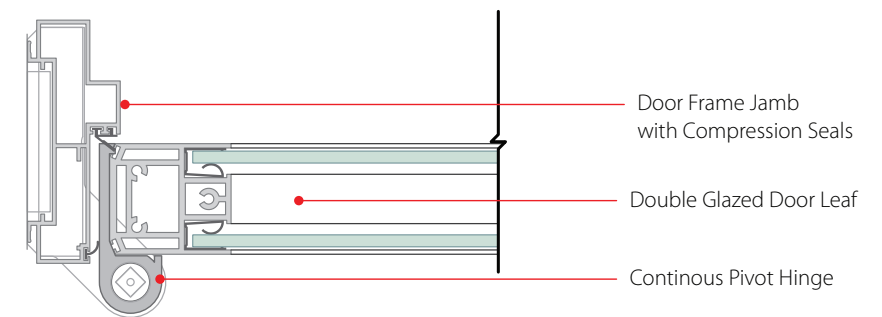

**HORIZONTAL SECTION**

- Continuous pivot hinge shown



**TECHNICAL GUIDE**

DOUBLE GLAZED SWING DOOR LEAVES + FRAMES

**DOOR AND FRAME FEATURES**



**CONCEALED CLOSER**

- Accommodates fully concealed door closer integrated into two-inch top rail

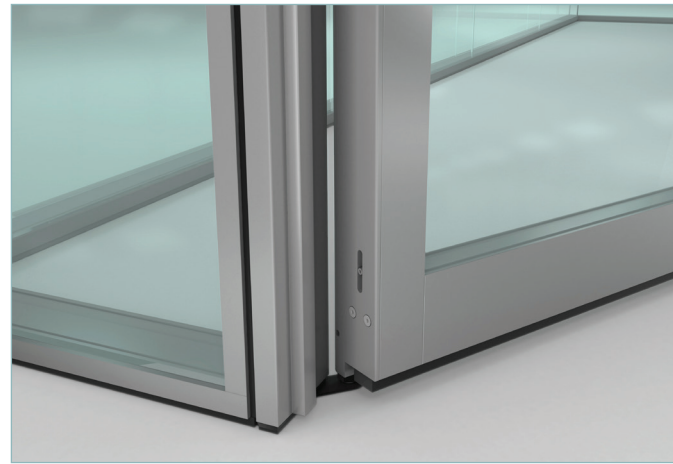

**ADJUSTABLE PLINTH + INTEGRATED AUTOMATIC DROP SEAL**

- Adjustable door bottom (plinth) provides maximum adjustability while minimizing gap beneath double glazed swing door leaf
- Integrated automatic drop seal to ensure air seal at floor



**ELECTRIC STRIKE**

- Factory prepped in door frame
- Requires field coordination of electrical hook-up

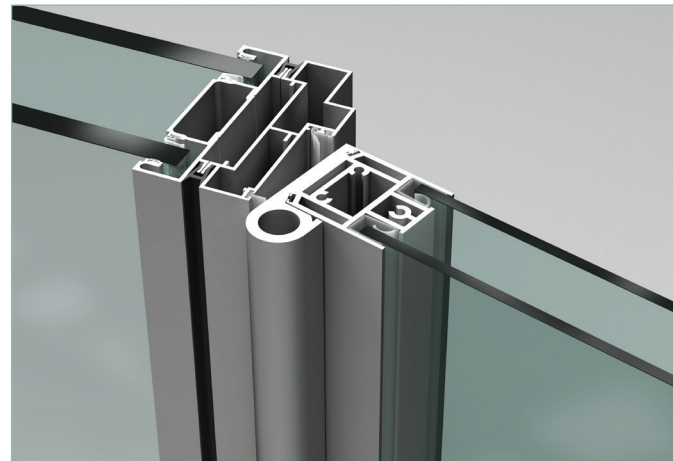

**COMPRESSION SEALS**

- Enhanced double compression seals to reduce incidental sound transmission along door perimeter

**LOCKS + PULLS**



**NON-LOCKING PULL**

- Options include:
- Tubular design
  - Architectural ladder pull



**CYLINDRICAL**

- Non-handed
- Cost effective
- Uses complementary patch to support locking mechanism



**MORTISE**

- Uses complementary patch to support locking mechanism
- Greater choice of lever designs and functions
- Wide range of supported manufacturers

**ARCHITECTURAL ELEVATIONS**



**FULL HEIGHT AND FULL HEIGHT WITH STACK-ONS**

- Ceiling heights available up to 120" (3048mm) or up to 144" (3658 mm) with stack-ons
- Not available with transoms



**TECHNICAL GUIDE**

DOUBLE GLAZED SLIDING DOORS

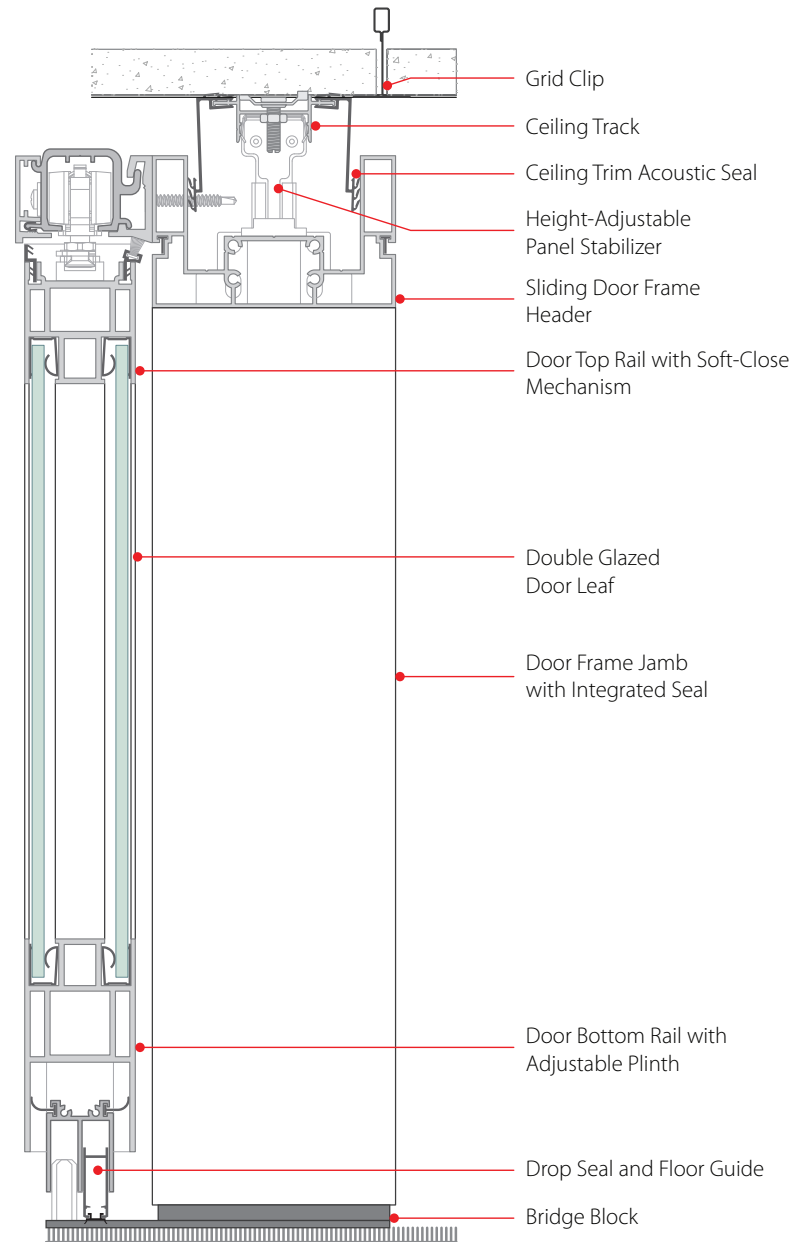

**VERTICAL SECTION**

- Integrated frame seals
- Adjustable plinth and automatic drop seal

**FEATURES**

- Double glazed sliding doors available with soft close mechanism
- Full-height door—up to 10 feet (3048 mm) without a transom—for improved aesthetics and lower cost across an entire wall front
- Lower cost advantage of factory assembled frames and doors, including electric strike options
- Adjustable door bottom (plinth) provides maximum adaptability and houses an integrated automatic drop seal
- Integrated strike and bypass seals to reduce incidental sound transmission at flanking paths
- Single sliding doors available with no structural support required above door while maintaining the non-marring attachment to base building

**SIZES | DIMENSIONS**

**Frame Width:**

SINGLE: 40" – 48" (1016 mm – 1219 mm)\*

DOUBLE: 80" – 96" (2032 mm – 2438 mm)\*

\* Frame widths are slightly larger than the actual leaf size.

**Frame Height:**

- Up to 120" (3048 mm) for full-height door; can add stack-ons above for up to 144" (3658 mm) overall height

- Can add stack-ons above for up to 144" (3658 mm) overall height when adjacent to unitized Enclose walls

**Glass Thickness (Glass Inset):** 3/16" (5mm) tempered

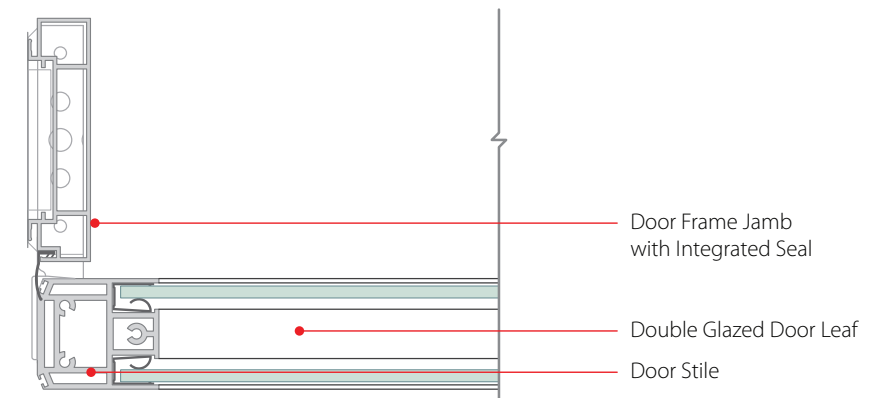

**HORIZONTAL SECTION**

- Integrated seals (strike jamb shown)
- Fourth point catch for additional security

**TECHNICAL GUIDE**

DOUBLE GLAZED SLIDING DOOR LEAVES + FRAMES

**DOOR AND FRAME FEATURES**



**SOFT CLOSE MECHANISM + TRACK**

- Concealed operator hardware
- Ensures consistent opening and closing operation



**ADJUSTABLE PLINTH + INTEGRATED AUTOMATIC DROP SEAL**

- Adjustable door bottom (plinth) provides maximum adjustability while minimizing gap beneath double glazed doors
- Integrated automatic drop seal to ensure air seal at floor

**LOCKS + PULLS**



**NON-LOCKING PULL**

- Options include:
- Tubular design
  - Architectural ladder pull



**DEADLOCK WITH D PULL**

- Discrete deadlock option with minimal patch housing
- Locking capability for doors with pulls



**MORTISE, SINGLE ACTION EGRESS**

- Available on single doors only
- Minimal patch housing
- Provides locking capability with single-action egress function

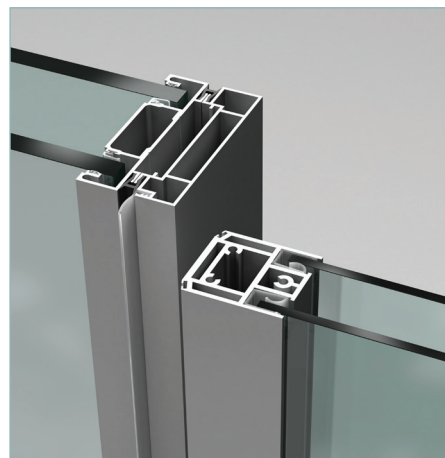

**INTEGRATED STRIKE + BYPASS SEALS**

- Integrated seals to reduce incidental sound transmission along door perimeter

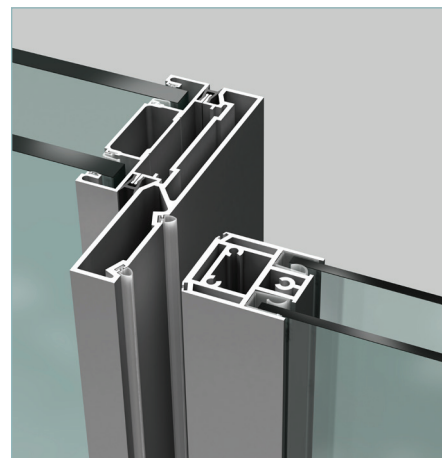

**LOCKING JAMB**

- Supports locking options for single door frames
- Includes integrated compression seals to reduce incidental sound transmission at locking jamb

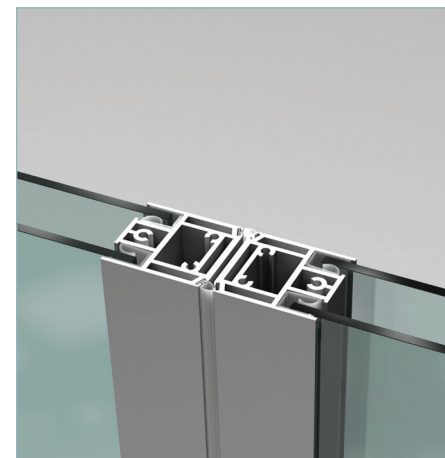

**DOUBLE DOOR SEALS**

- Includes integrated compression seals to reduce incidental sound transmission at inactive door leaf stile

**ARCHITECTURAL ELEVATIONS**



**FULL HEIGHT + FULL HEIGHT W/ STACK-ONS**

- Ceiling heights available up to 120" (3048mm) or up to 144" (3658mm) with stack-ons
- Not available with transoms



## TECHNICAL GUIDE

# PANELS: GLASS

Rapid office front construction is possible using Enclose unitized glass panel, which are factory assembled, delivered to site, and installed using tilt-up construction by a single trade. With powder-coated recycled aluminum—up to 80 percent recycled—it's a more durable finish that's easy to touch up in the field. Enclose framed glass is built to the millimeter in both width and height—allowing for a custom, built-in aesthetic. And, Haworth framed glass panels count toward LEED points.

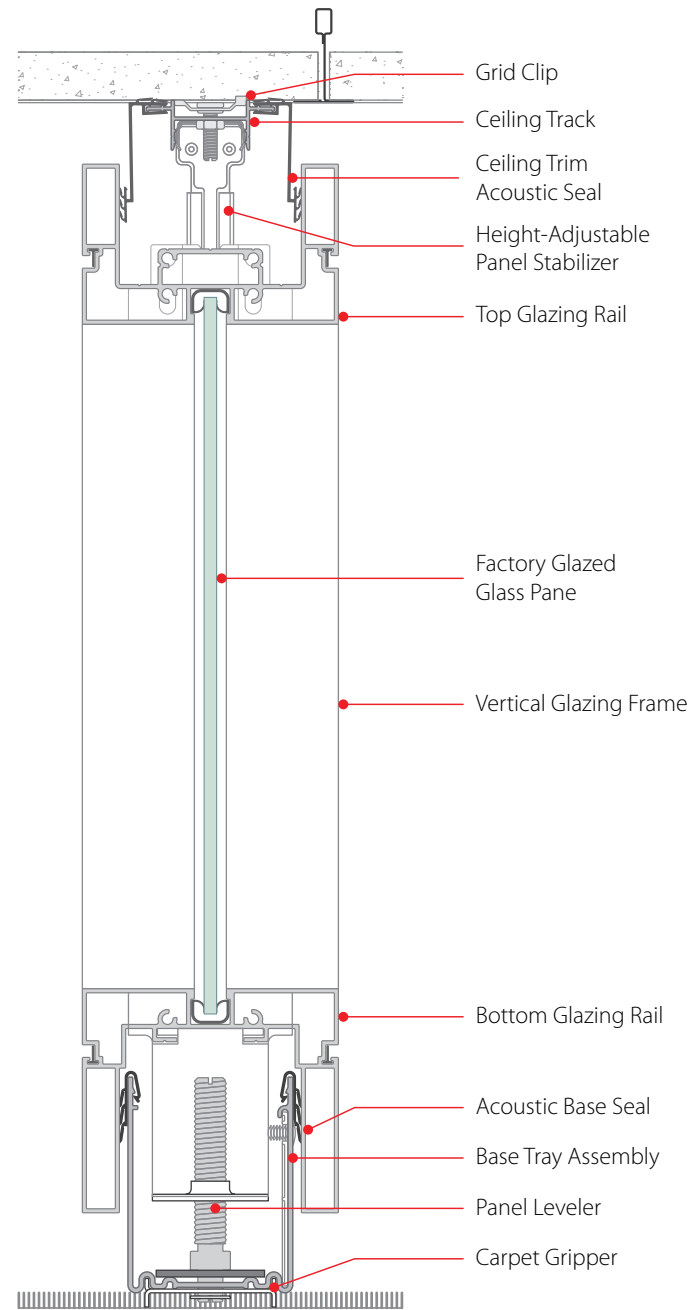

VERTICAL SECTION

## FEATURES

- Panels may be specified in 1 mm increments in both height and width for equal spacing, and modules that allow ease of change
- Powder-coated aluminum that is easily touched up in the field, and looks good after adds, moves, and changes
- Details to complement finishes—including Black or Grout (Grey) reveals and Black or Clear glazing beads
- Acoustic seals create an acoustic envelope that prevents sound transmission
- Non-marring attachment to base building with a modular floor connection that rests on the finished floor and removeable grid clips that accommodate most ceiling types
- Tilt-up installation with easy attachment at the ceiling to reduce handling of factory assembled wall panel—no site assembly required

## SIZES | DIMENSIONS

- Width: 8" – 60" (203 mm – 1524 mm)
- Height: Up to 144" (3658 mm)
- Glass Thickness: 1/4" (6mm) – 3/8" (10 mm) tempered or laminated glass
- Vertical Adjustment: Up 1 3/4" (44 mm) or down 3/4" (19 mm)
- Horizontal Alignment: 1/16" (1 mm) width increments to align with base building

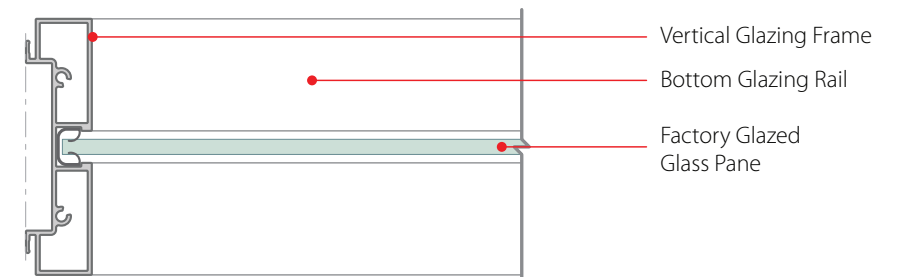

HORIZONTAL SECTION

**TECHNICAL GUIDE**

PANELS: GLASS DETAILS

ARCHITECTURAL OPTIONS



**MUNTIN**

- 7/8" (22 mm) profile for division of glass and architectural alignment

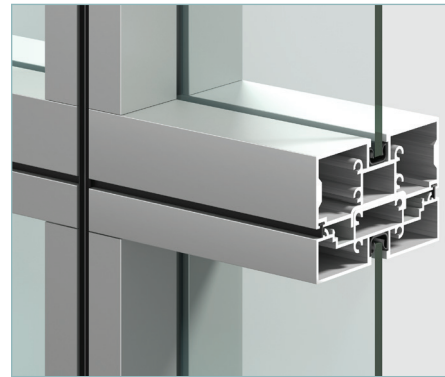

**TRANSOM RAIL**

- 2 1/2" (64mm) profile for entrance system and architectural alignment
- Supports track for sliding door with transom



**CLERESTORY ALIGNMENT**

- Glass panels with transom align seamlessly to clerestory

ARCHITECTURAL ELEVATIONS



**GLASS**



**GLASS WITH TRANSOM**

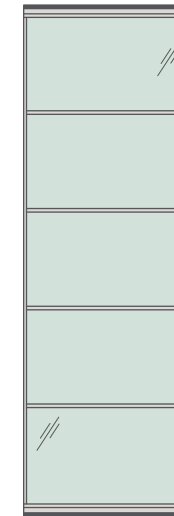

**GLASS WITH MUNTINS**



**2-WAY 90° GLASS CORNER**

- Overlap glass joint
- Bright metal corner cap
- Minimum 12" (305 mm), maximum 48" (1219 mm)



**2-WAY 135° GLASS CORNER**

- Butt-joint glass
- Minimum 12" (305 mm), maximum 48" (1219 mm)



**3-WAY 90° GLASS CORNER**

- Butt-joint glass
- Top of the T: minimum 18" (457 mm), maximum 48" (1219 mm)
- Spline of the T: minimum 12" (305 mm), maximum 48" (1219 mm)

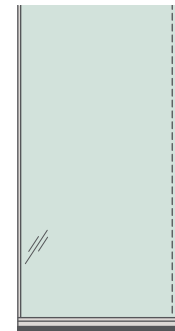

**2-WAY 90° GLASS CORNER**

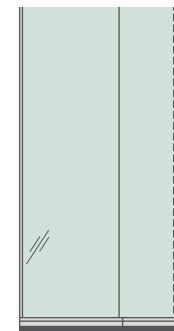

**2-WAY 135° GLASS CORNER**

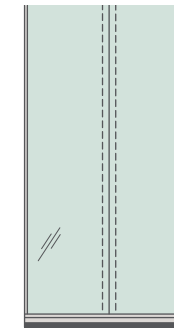

**3-WAY 90° GLASS CORNER**



**TECHNICAL GUIDE**

**PANELS: SOLID**

Enclose unitized wall panels with removable tiles are factory assembled, giving you the fluidity to install them using a single tradesperson so you can stay on schedule. The removable tile facilitates easy access to electrical and data, and supports seamless integration of LCD monitors and AV technology. Haworth offers the most tile options in the industry, from painted or wall covering to laminate or wood, to writable and magnetic surfaces. Our choices in wall materials accommodate your project needs—whether you’re seeking LEED points, non-combustible finishes, or simply the best value.

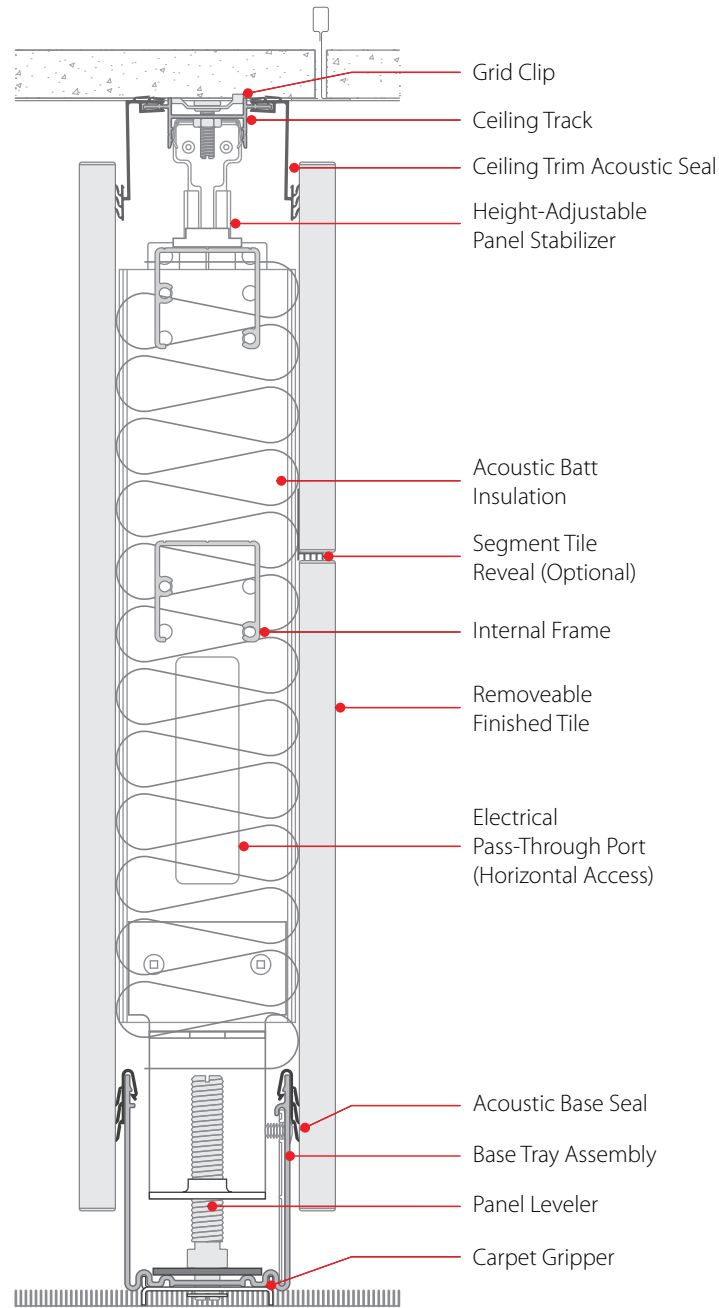

VERTICAL SECTION

**FEATURES**

- Acoustic seals create an acoustic envelope that minimizes sound transmission
- Non-marring attachment to base building with a modular floor connection that rests on the finished floor, and removable grid clips that accommodate most ceiling types
- Tilt-up installation with easy attachment at the ceiling to reduce handling of factory assembled wall panel—no site assembly required
- Integrated slotted standards accommodate mounting of furniture and accessories by Haworth or other manufacturers
- Electrical and data can be routed vertically from the ceiling to the floor or horizontally—via the bottom raceway—from panel to panel
- Monolithic or segmented tiling with ability to mix it up on either side of the panel and select from a variety of finishes and substrates

**SIZES | DIMENSIONS**

Width: 8"– 60" (203 mm – 1524 mm) – maximum width depends on finish selection  
 Height: up to 144" (3658 mm)  
 Vertical Adjustment: Up 1 3/4" (44 mm) or down 3/4" (19 mm)  
 Horizontal Alignment: 1/16" (1 mm) width increments to align with base building

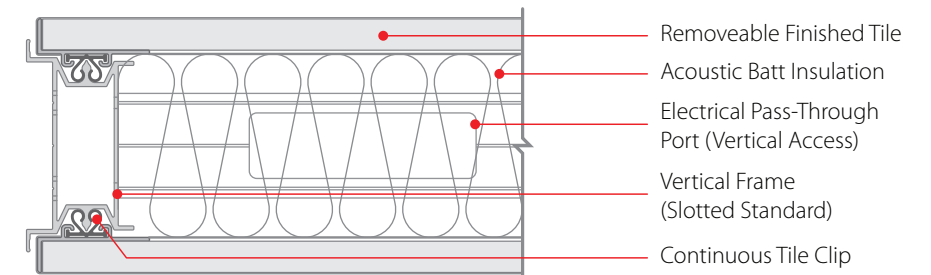

HORIZONTAL SECTION

**TECHNICAL GUIDE**

PANELS: SOLID WALL DETAILS

**PERFORMANCE**



**INTEGRATED SLOTTED STANDARD**

- Furniture/component mounting—whether by Haworth or other manufacturers
- Accessory mounting
- Audio/visual equipment mounting



**CUTTABLE PANEL**

- Can be scribed to base building
- Top/side cuttable
- Can be specified in both full-height or segmented
- Cannot be used with glass tiles



**REMOVEABLE TILE**

- Ships and installs with tiles attached
- Allows easy interior cavity access to support changes, routing of electrical/data, or structural mounting support
- No tools required to remove tile

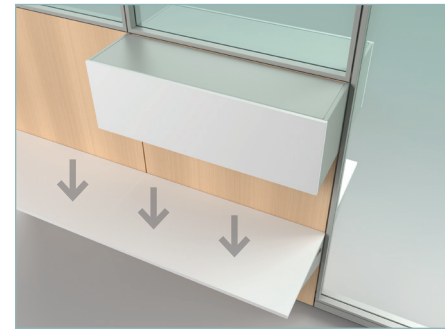

**STABILITY + STRUCTURE**

- Engineered to meet North American building codes for maximum size
- Can be installed in all seismic areas—incl. freestanding, with or without furniture
- Box-section vertical framing with integrated slots ensures all solid panels can support furniture components

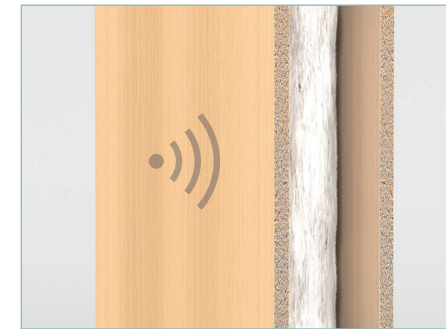

**ACOUSTICAL**

- Closed-cell foam gasket between ceiling track and ceiling
- Panel connectors between panels with integral acoustical sealing fin
- Wall cavity insulation is glass fiber—proven material, free of formaldehyde and fire-retardants
- Steel tiles tuned to provide the benchmark STC value without additional treatment
- All STC performance claims based on standard product, and require no special installation practices or scribing of tiles to fit site conditions

**ARCHITECTURAL OPTIONS**



**TILE CONFIGURATION**

- Full-height or segmented up to five segments
- No set sizes—follows architectural elevation
- Full-height on one side and segmented on the other if you choose

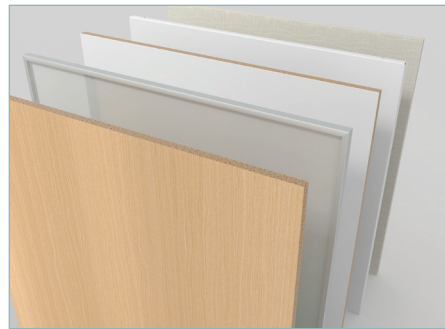

**TILE OPTIONS**

- Select from Haworth's Integrated Palette
- Ability to tailor finishes with furniture and base building

FINISHES	SUBSTRATES					
	Drywall	Particleboard	NAUF	FR Board	Steel	Glass
Paint	X					
Wall Covering	X					
Fabric	X					
High Pressure Laminate		X	X	X		
Low Pressure Laminate		X				
Veneer		X	X	X		
Whiteboard Laminate		X	X	X		
Smooth Powdercoat					X	
Textured Powdercoat					X	
Backpainted						X
Magnetic					X	X

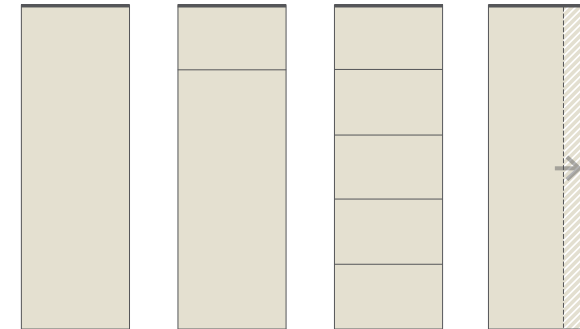

- A** Solid
- B** Solid with Transom
- C** Solid with Segmented Tiles
- D** Variable Width (Cuttable)



**TECHNICAL GUIDE**

**PANELS: COMBINATION**

Enclose unitized solid/glass or glass/solid combination wall panels balance visual privacy and acoustical privacy through an array of design options. They also count toward LEED points because they let daylight into your space. Choose as large of a window as you desire with our 1/16" (1 mm) increments and mount furniture along the wall panel vertical.

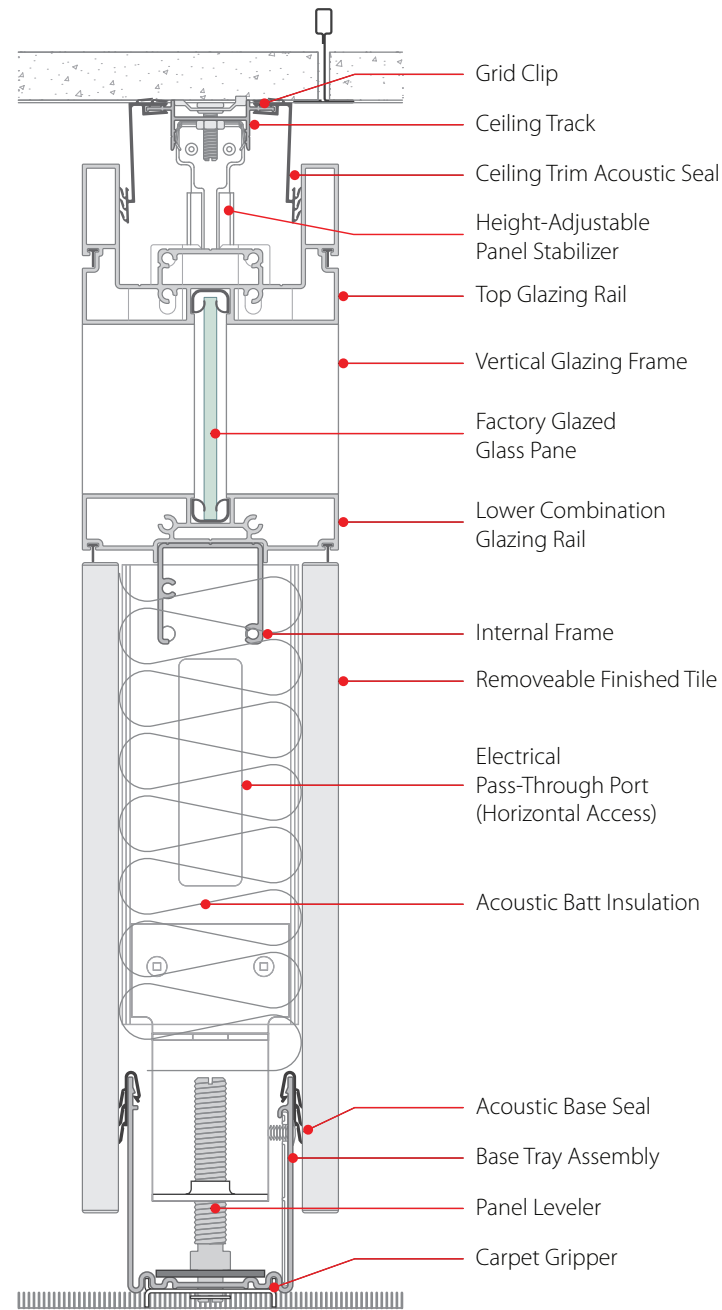

VERTICAL SECTION

**FEATURES**

- Acoustic seals create an acoustic envelope that prevents sound transmission; panel is fully insulated for acoustic performance
- Non-marring attachment to base building with a modular floor connection that rests on the finished floor and removeable grid clips that accommodate most ceiling types
- Tilt-up installation with easy attachment at the ceiling to reduce handling of factory assembled wall panel—no site assembly required
- Aligns to muntins or transom on glass fronts and doors
- Integrated slotted standards accommodate mounting of furniture and accessories by Haworth or other manufacturers
- Monolithic or segmented tiling of both solid and glass segments with ability to mix it up on either side of the panel and select from a variety of finish and substrate options

**SIZES | DIMENSIONS**

Width: 8" – 60" (203 mm – 1524 mm) – maximum width depends on finish selection  
 Height for Solid in Solid/Glass Combination: minimum 17 3/16" (437 mm), maximum is ceiling height minus 8 7/8" (225 mm)  
 Height for Glass in Glass/Solid Combination: minimum 82" (2083 mm), maximum is ceiling height minus 8 7/8" (225 mm)  
 Glass Thickness: 1/4" – 3/8" (6 mm – 10 mm) tempered or laminated glass  
 Vertical adjustment: Up 1 3/4" (44 mm) or down 3/4" (19 mm)  
 Horizontal alignment: 1/16" (1 mm) width increments to align with base of building

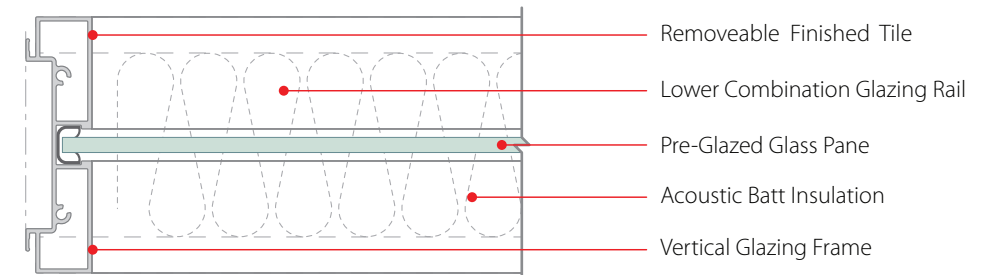

HORIZONTAL SECTION

**TECHNICAL GUIDE**

PANELS: COMBINATION GLASS DETAILS

**PERFORMANCE**



**SOLID-GLASS**

- Framing 7/8" (22 mm)
- Aligns to muntins



**GLASS-SOLID**

- Specify height
- Solid options



**TRANSOM OPTION**

- Framing 1 3/8" Framing (36 mm)
- Aligns to transom at entrance system and glass panels



**CLERESTORY ALIGNMENT**

- Glass panels with transom align seamlessly to clerestory



**CUTTABLE PANELS**

- Site fit to base building construction
- Creates built-in aesthetic around various building conditions

**ARCHITECTURAL OPTIONS**

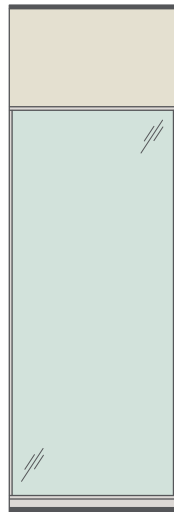

**COMBINATION GLASS-SOLID**

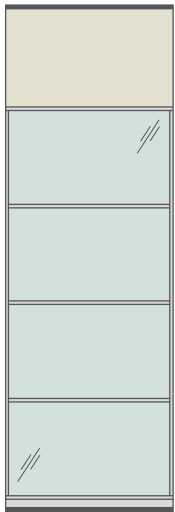

**COMBINATION GLASS-SOLID WITH MUNTINS**

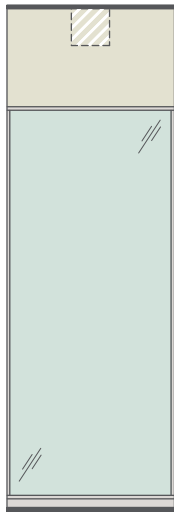

**COMBINATION GLASS-SOLID TOP CUTTABLE**

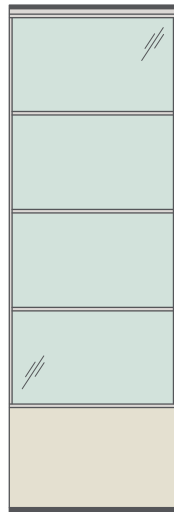

**COMBINATION SOLID-GLASS WITH MUNTINS**

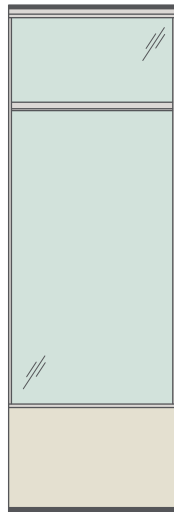

**COMBINATION SOLID-GLASS WITH TRANSOM**

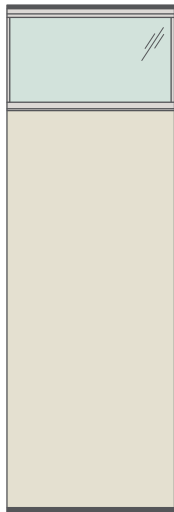

**COMBINATION SOLID-GLASS TILE TO TRANSOM**



## TECHNICAL GUIDE

# ENCLOSE STOREFRONT GLAZING OPTIONS

### APPLICATION TYPES

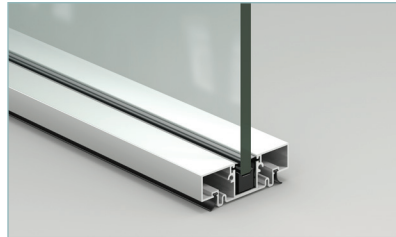

1 Channel Center Glazing

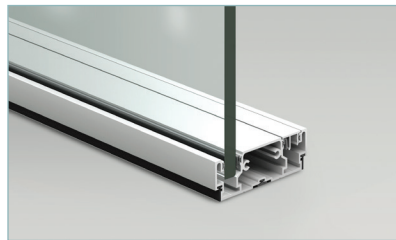

2 Channel Offset Glazing

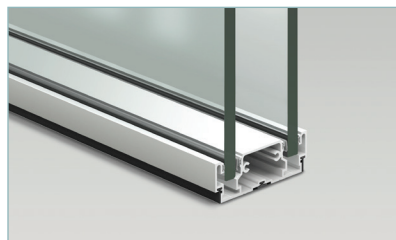

2 Channel Double Glazing

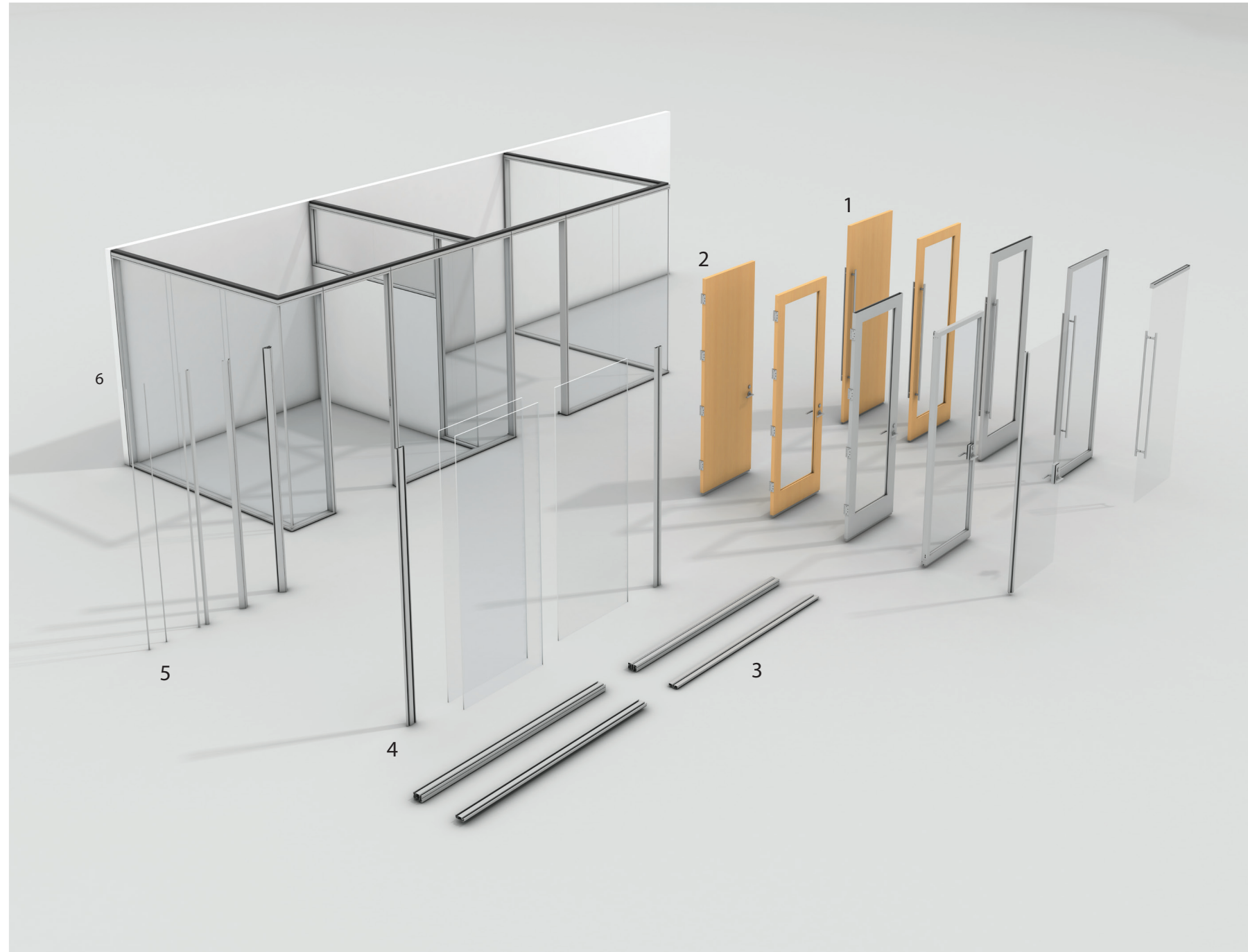

#### 1: SLIDING DOORS

- Wood Slab + Wood Glazed
- Metal Glazed
- Double Glazed
- Glass Slab

#### 2: SWING DOORS

- Wood Slab + Wood Glazed, Butt Hinge
- Metal Glazed, Butt Hinge
- Double Glazed, Pivot Hinge
- Glass Slab, Pivot Hinge

#### 3: FRAMELESS GLASS, CENTER CHANNEL

- Full-Height and Stack-ons
- Single Glazing, Center Mount
- 3/8" + 1/2" Glass

#### 4: FRAMELESS GLASS, 2 CHANNEL

- Full-Height
- Double + Single Offset Glazing
- 3/8" + 1/2" Glass

#### 5: GLASS JOINT + CORNERS

- Inline
- 2-Way 90°
- 2-Way Variable Angle
- 3-Way 90°

#### 6: FLY-BY + TRANSITIONS

- Flush Fly-by Post
- Chamfer Fly-by Post, EFG + EFG 2 Channel
- Center Bridge Post
- FIP Hardwall + Mullion Starter

**TECHNICAL GUIDE**

**FRAMELESS GLASS**

Enclose Frameless Glass provides a storefront option that integrates visually with the rest of the Enclose system or stands on its own. With the lowest base profile in the industry and refined details like butt-jointed glass and bright aluminum corners, the design is clean and uncomplicated from top to bottom. The system touches the building lightly, using mechanical fasteners only at the slab to save you time and money every time you install or move a wall. No bulkheads, tie rods, or steel structures are required to support the weight of the door, giving you flexibility to design within the architecture of the building.

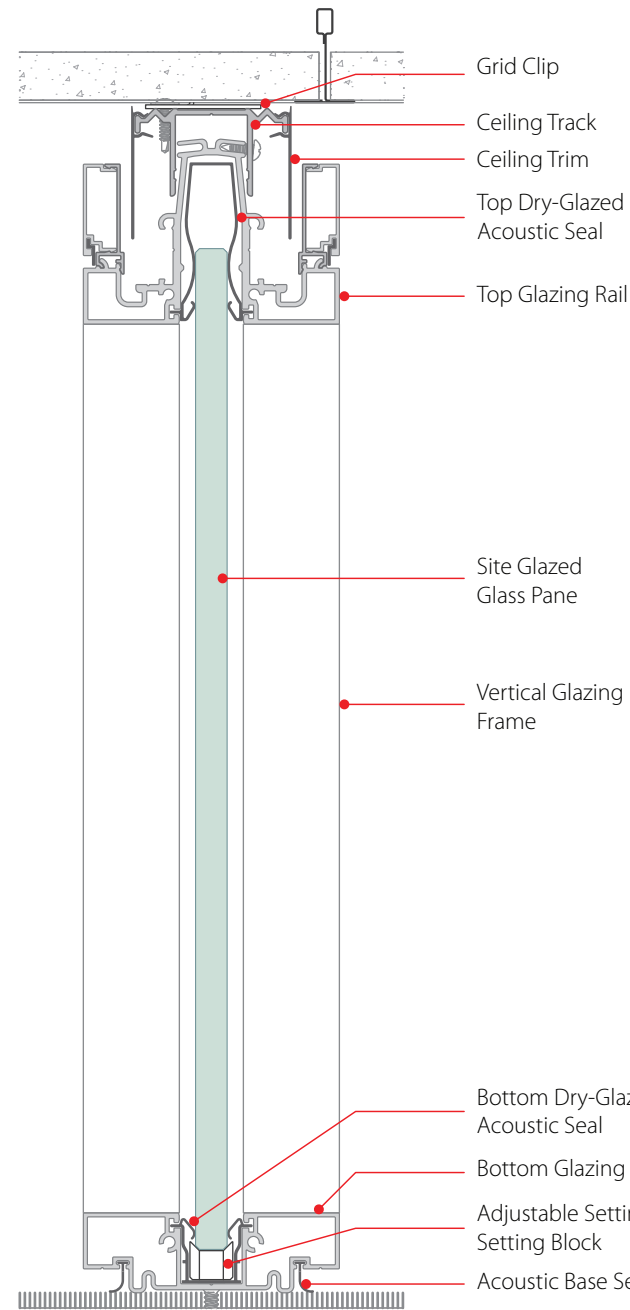

VERTICAL SECTION

**FEATURES**

- Butt-jointed glazing for maximum transparency
- Acoustic seals create an acoustic envelope that minimizes sound transmission
- Integrated adjustable setting blocks allows glass to be plumbed with ease
- Glass is locally sourced for quick delivery and site assembly
- Stands on its own as a storefront, or integrates with Enclose for a cohesive look from glass to solid walls
- Maintains flexibility with removeable grid clips to accommodate most ceiling grid types and a mechanical fastener only at the floor; no bulkheads, tie rods or steel structure required to support the system
- Powder-coated aluminum that is easily touched up in the field, and looks good after adds, moves, and changes
- Details to complement finishes—including Black or Grout (Grey) reveals and Black or Clear glazing beads

**SIZES | DIMENSIONS**

- Bottom Rail Height: 7/8" (22 mm)
- Width: Glass module as required to span overall dimension
- Height: Up to 144" (3658 mm)
- Glass Thickness: 3/8" (10 mm) tempered, up to 9' (2.74 m) ceiling heights  
 1/2" (12 mm) tempered or laminated glass
- Vertical Adjustment: +/- 3/4" (19 mm)
- Horizontal Alignment: Manufactured to fit the base building , minimum 12" (305 mm)

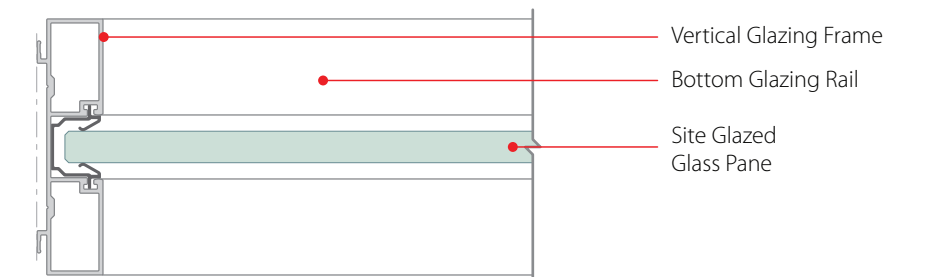

HORIZONTAL SECTION



**TECHNICAL GUIDE**

FRAMELESS GLASS DETAILS

**ARCHITECTURAL DETAILS**

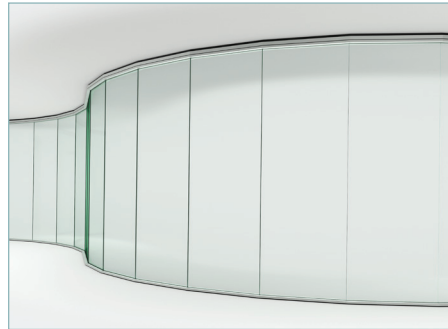

**FACETED**

- Design freedom for curvilinear fronts
- Silicone or variable angle joints

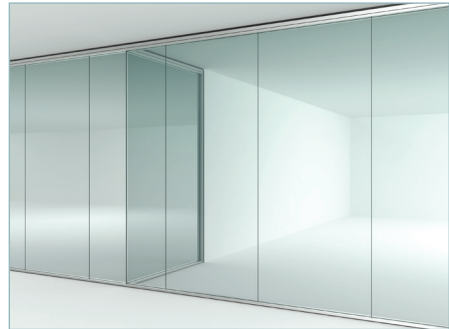

**UNLIMITED SPAN**

- Design freedom to create glass fronts with no restrictions on maximum width
- Supports increased transparency and access to daylight



**ALIGNS WITH FRAMED GLASS**

- Part of the Enclose product family
- Consistent product alignment points
- Integrated surface material palette

**ARCHITECTURAL ELEVATIONS**

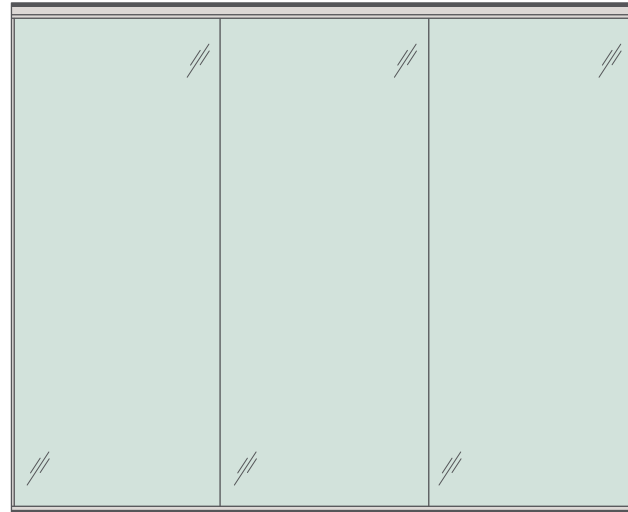

**FRAMELESS GLASS**

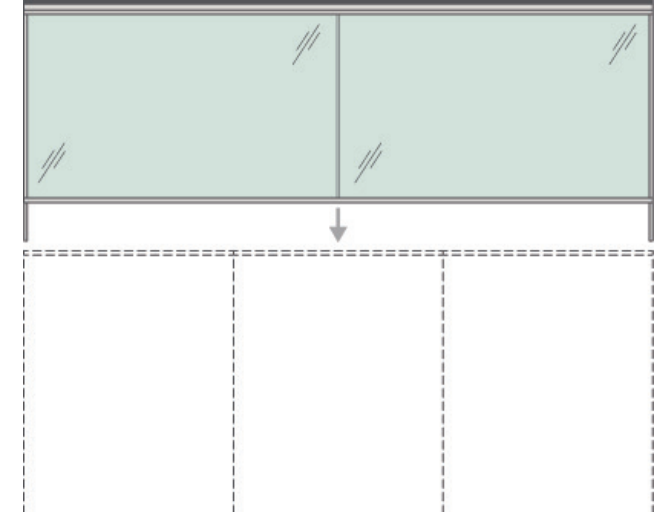

**FRAMELESS GLASS STACK**

**CROSS SECTION DETAILS**

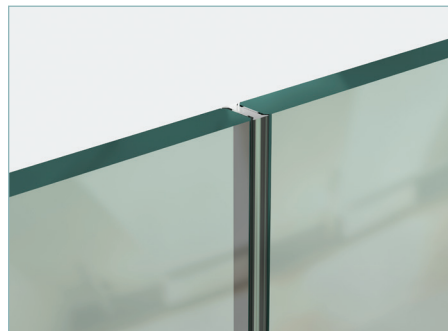

**BUTT-JOINT GLASS**

- Can be specified as:
- Silicone
  - Tape
  - Polycarbonate extrusion

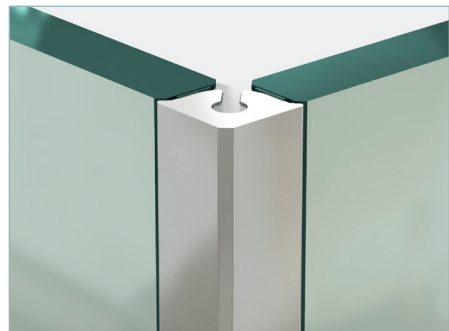

**GLAZING TRANSITIONS**

- Available finishes:
- Polycarbonate
  - Silicone
  - Painted metal or bright metal

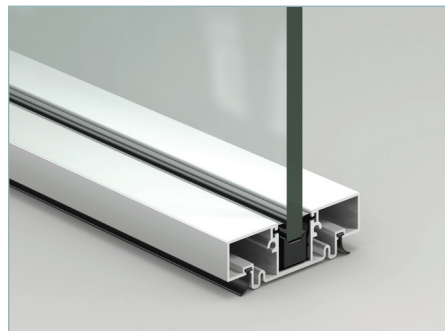

**LOW BASE**

- 7/8" (22mm) low profile
- Extends visual transparency

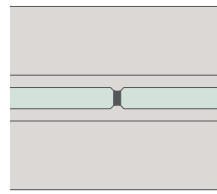

**INLINE 180°**

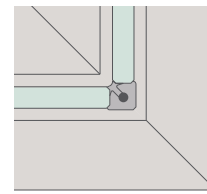

**2-WAY 90°**

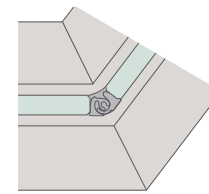

**VARIABLE ANGLE**

**TECHNICAL GUIDE**

FRAMELESS GLASS, 2 CHANNEL

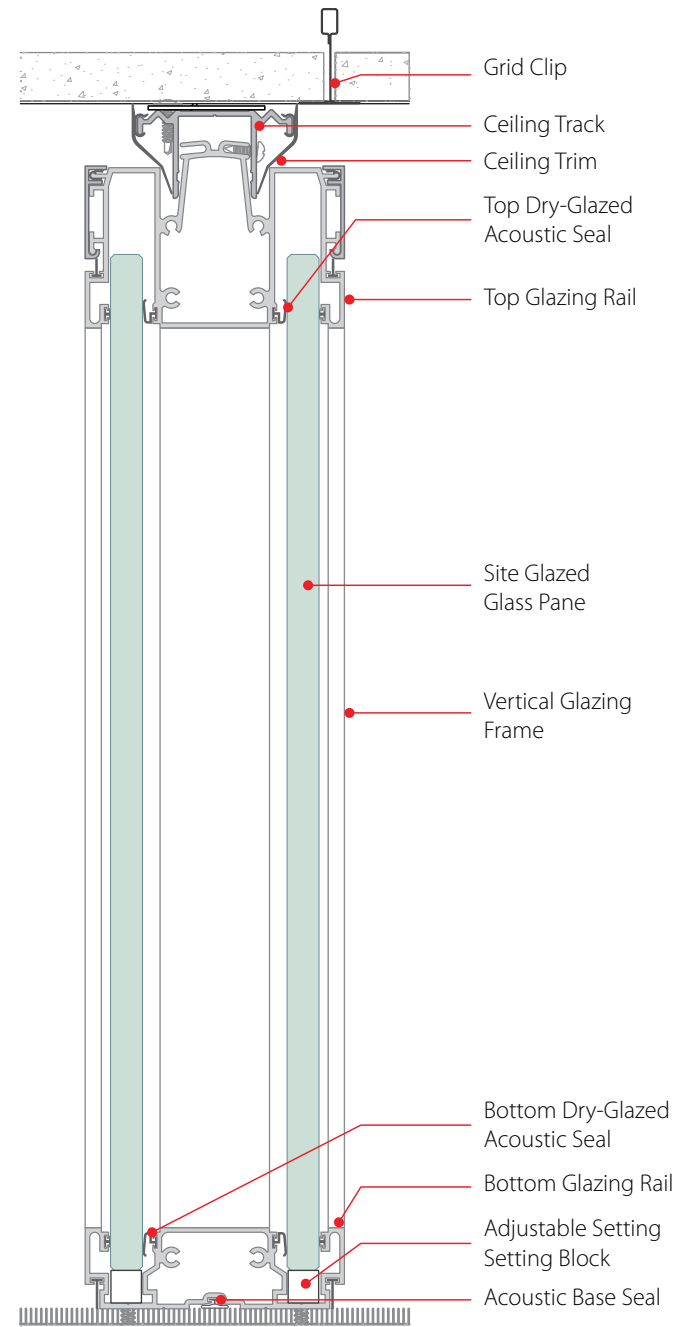

VERTICAL SECTION

**FEATURES**

- Butt-jointed double glazing for maximum transparency and acoustic performance
- Offers adaptable options for double glazed or single offset glazed walls
- Seals create an acoustic envelope that minimizes sound transmission
- Integrated adjustable setting blocks allow for easy plumbing of glass
- Locally sourced glass for quick delivery and site assembly
- Functions on its own as a storefront, or integrates with Enclose for a cohesive look from glass to solid walls
- Maintains flexibility with removeable grid clips to accommodate most ceiling grid types and a mechanical fastener only at the floor; no bulkheads, tie rods, or steel structure required to support the system
- Powder-coated aluminum that is easily touched up in the field, and looks good after adds, moves, and changes
- Details to complement finishes—including Black or Grout (grey) reveals and Black or Clear glazing beads

**SIZES | DIMENSIONS**

- Bottom Rail Height:** 7/8" (22 mm)
- Width:** Glass module as required to span overall dimension
- Height:** Up to 144" (3658 mm)
- Glass Thickness:** 3/8" (10 mm) tempered, up to 9' (2.74 m) ceiling heights  
1/2" (12 mm) tempered or laminated glass
- Vertical Adjustment:** +/- 3/4" (19 mm)
- Horizontal Alignment:** Manufactured to fit the base building, 12" (305 mm)

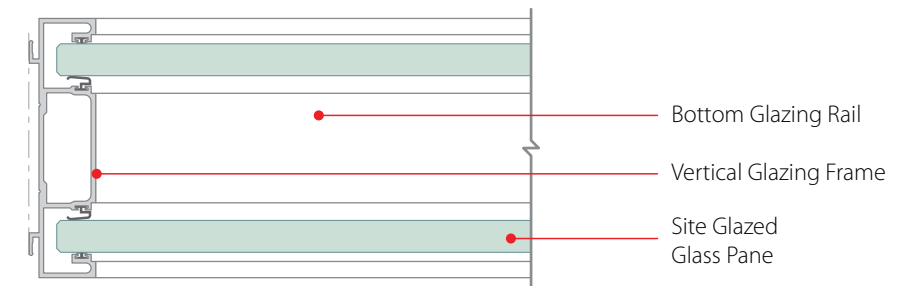

HORIZONTAL SECTION



**TECHNICAL GUIDE**

FRAMELESS GLASS, 2 CHANNEL DETAILS

ARCHITECTURAL DETAILS AND FEATURES



ALIGNS WITH EXISTING ENCLOSE PRODUCTS

- Part of the Enclose product family
- Consistent product alignment points
- Integrated surface material palette



FLUSH FLY-BY, EFG 2 CHANNEL

- Low profile interface with double perimeter seal
- Allows for minimal door frame proximity
- Off-module interface with glass front



ADJUSTABLE FIP HARDWALL/MULLION STARTER

- Patent pending interface solution to accommodate various architectural abutments
- Adjustable cladding can accommodate widths of 2.25" (58mm) to 5.5" (140mm)

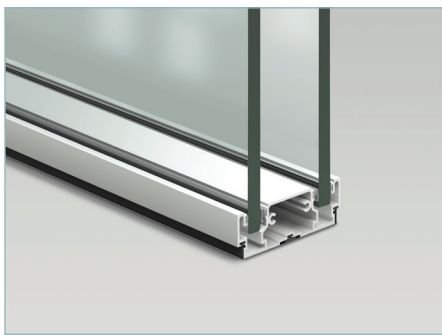

DOUBLE GLAZING

- 7/8" (22mm) low profile
- Supports increased transparency and access to daylight

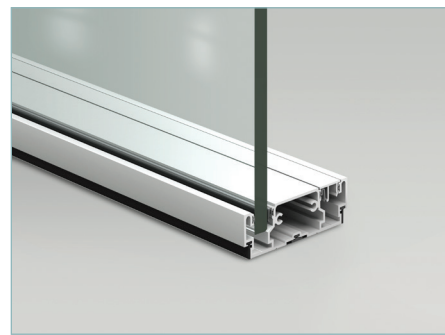

OFFSET GLAZING

- Framing accommodates offset glazed applications for those areas not requiring double glazing
- Inactive channels are discreetly capped but remain available for future glazing additions

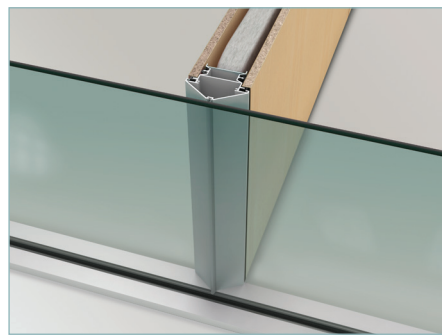

CHAMFER FLY-BY, EFG 1 CHANNEL

- Off-module interface with glass front for center glazed applications
- Includes an acoustic bulb seal to minimize incidental sound transmission

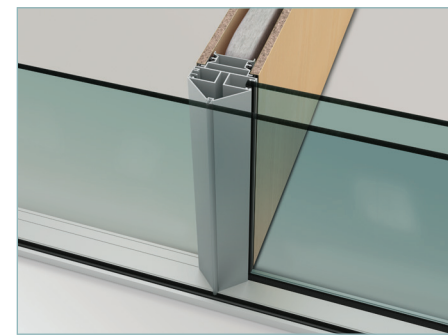

CHAMFER FLY-BY, EFG 2 CHANNEL

- Off-module interface with glass front for double glazed applications
- Provides multiple seal points at divider wall location
- Allows transitions of double to single glazing applications

**TECHNICAL GUIDE**

FRAMELESS GLASS, 2 CHANNEL DETAILS

**ARCHITECTURAL DETAILS AND FEATURES**

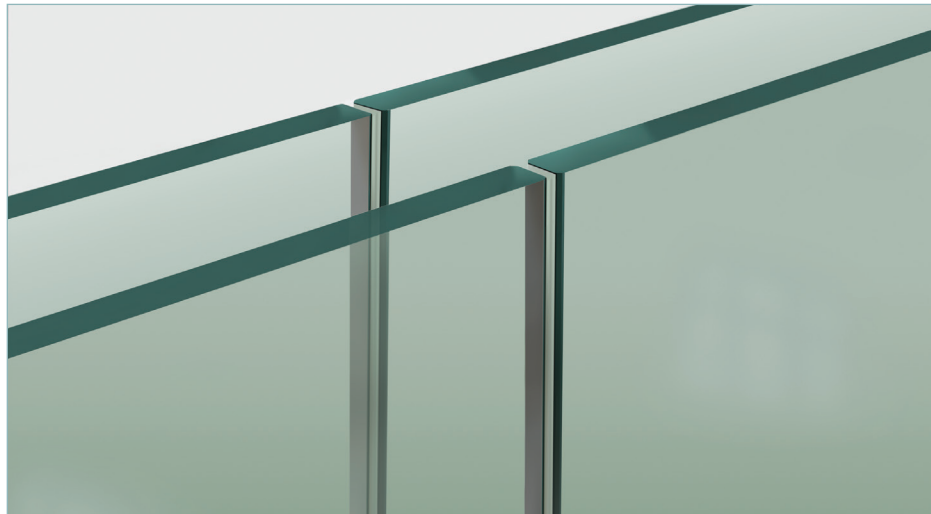

INLINE GLAZING CONNECTORS, PLASTIC + TAPE

- Can be specified as:
- Tape
  - Plastic extrusion

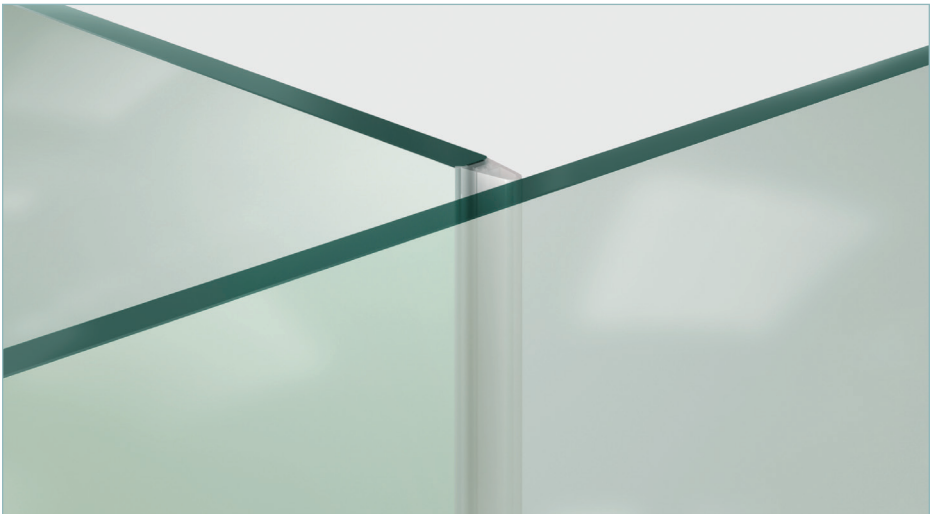

FLY-BY PLASTIC CONNECTOR

- Dry joint interface to accommodate perpendicular and angular glazing transitions

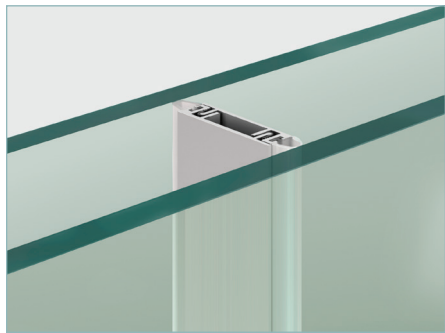

CENTER BRIDGE CONNECTOR

- Discreet center bridge connector seals internal cavity of double glazed assemblies
- Available in painted finishes

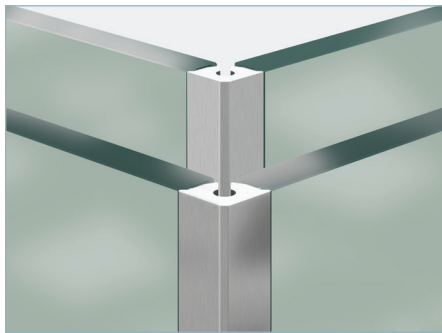

GLAZING CONNECTORS, 2 WAY 90 + VARIABLE

- Available in:
- Clear plastic, painted metal, or bright metal finishes
  - Fixed 90-degree or variable-angle transitions (90 degrees to 180 degrees)

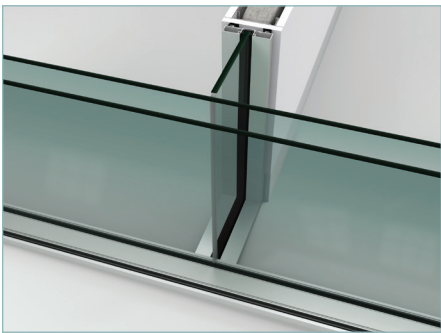

CENTER GLAZED TO DOUBLE GLAZED

- Extends visual transparency
- Single glazed divider can also be used as a transition to Enclose solid walls or drywall partitions

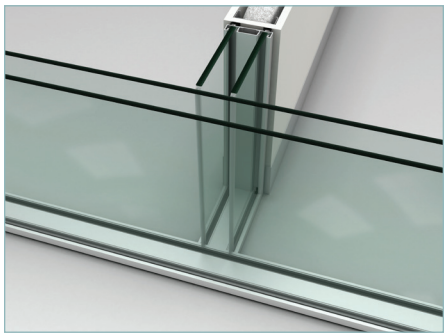

DOUBLE GLAZED TO DOUBLE GLAZED

- Extends visual transparency
- Double glazed divider can also be used as a transition to Enclose solid walls or dry wall partitions
- Enhanced acoustical performance



**TECHNICAL GUIDE**

TRANSITIONS: 2-WAY

**ARCHITECTURAL OPTIONS**



2-WAY 90° GLASS CORNER

- Overlap glass joint
- Bright metal corner cap
- Minimum 12" (305 mm), maximum 48" (1219 mm)

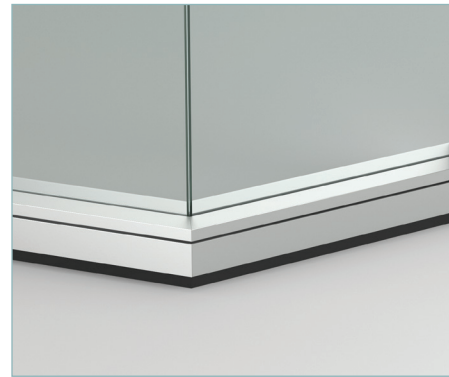

2-WAY 135° GLASS CORNER

- Butt-joint glass
- Minimum 12" (305 mm), maximum 48" (1219 mm)

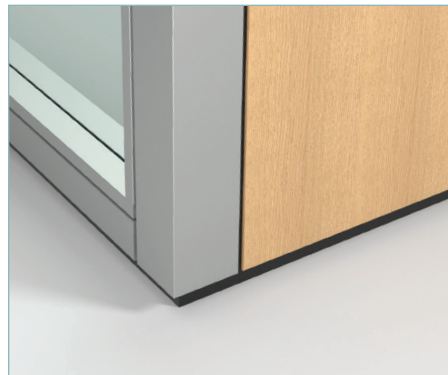

2-WAY 90° POST

- 4" x 4" (102 mm x 102 mm) system module corner post
- Available in painted metal, wall covering, or wood

**GLASS CORNERS**

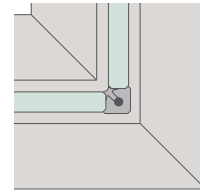

2-WAY 90° CROSS SECTION METAL CAP SHOWN

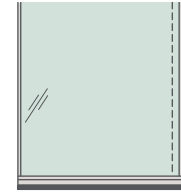

2-WAY 90° ELEVATION

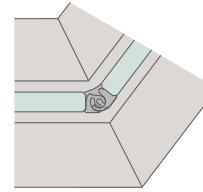

VARIABLE ANGLE

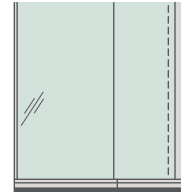

2-WAY 135° ELEVATION

**TRANSITION POSTS**

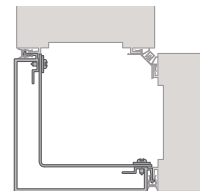

2-WAY 90° CLOSED

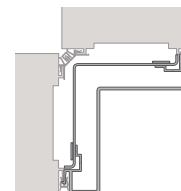

2-WAY 90° OPEN

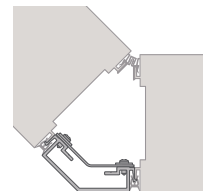

2-WAY 135°

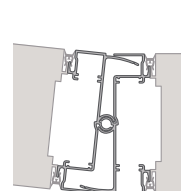

VARIABLE ANGLE 168° – 179° (PAINTED METAL ONLY)

**BUILDING MODULE TRANSITIONS**

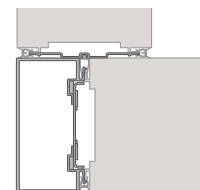

2-WAY 90° CENTERLINE

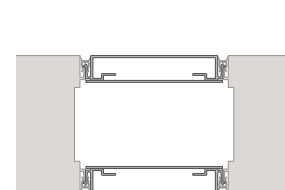

4" OR 6" (106 MM OR 152 MM) 180° IN LINE

**TECHNICAL GUIDE**

TRANSITIONS: FRAMELESS GLASS 2-WAY

**ARCHITECTURAL OPTIONS**

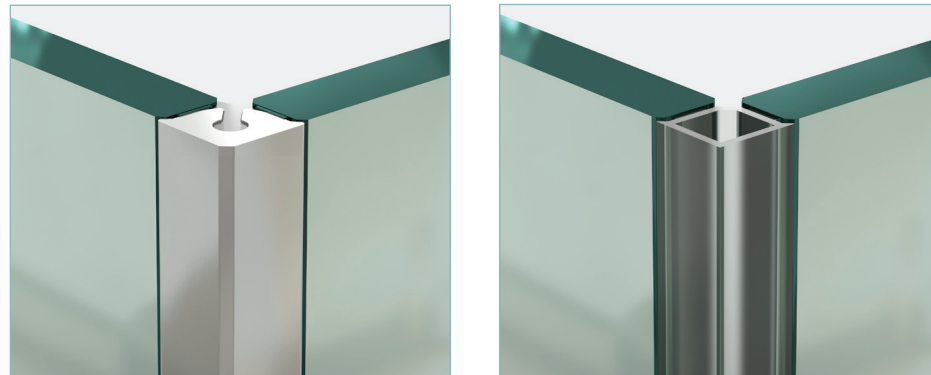

2-WAY 90° CORNERS

- Frameless glass 90° corners can be specified as:
- Extruded metal in anodized, bright metal or painted finish
  - Extruded clear polycarbonate
  - Overlap joint sealed with silicone

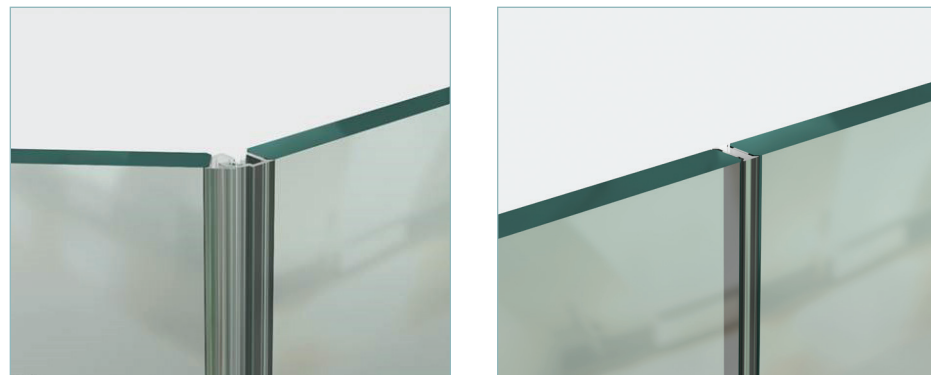

VARIABLE ANGLE CORNERS

- Frameless glass variable angle corners can be specified in angles from 90.5° – 179.5° in .5° increments
- Finished with either a bright metal or clear polycarbonate seal

INLINE TRANSITIONS

- Butt-joint transitions can be specified with:
- Silicone
  - Tape
  - Extruded polycarbonate

**90° GLAZING CONNECTORS**

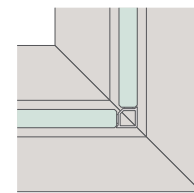

2-WAY 90° WITH TREATED METAL CONNECTOR

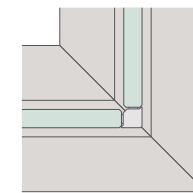

2-WAY 90° WITH PLASTIC CONNECTOR

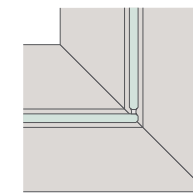

2-WAY 90° OVERLAP JOINT (RIGHT-HAND SHOWN)

**VARIABLE ANGLE GLAZING CONNECTORS**

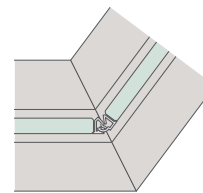

2-WAY VARIABLE WITH TREATED METAL CONNECTOR

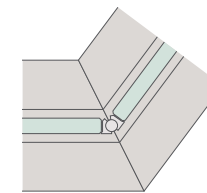

2-WAY VARIABLE WITH PLASTIC CONNECTOR

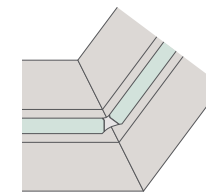

2-WAY VARIABLE WITH SILICONE

**GLASS INLINE GLAZING CONNECTORS**

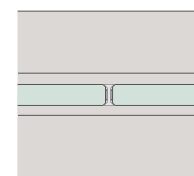

PLASTIC

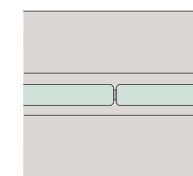

TAPE

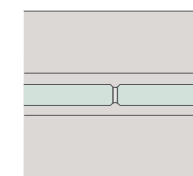

SILICONE



**TECHNICAL GUIDE**

TRANSITIONS: 3-WAY

**ARCHITECTURAL OPTIONS**



**3-WAY SYSTEM MODULE**

- 4" x 4" (102 mm x 102 mm) transition post
- Available in painted metal, wall covering or wood



**3-WAY GLASS CORNER**

- Butt-joint glass transition
- Top of the T: minimum 18" (457 mm), maximum 48" (1219 mm)
- Spline of the T: minimum 12" (305 mm), maximum 48" (1219 mm)

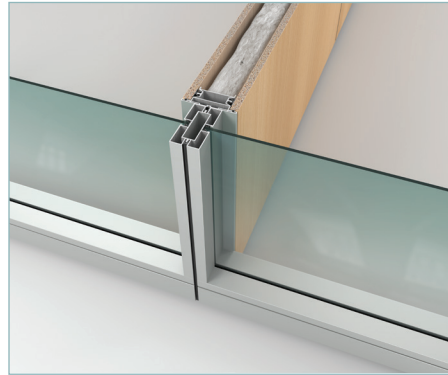

**3-WAY CENTERLINE**

- Used to connect Enclose panels without a traditional system module post
- Aligns panel centerline dimensions to the building module



**FILLER FIN**

- 3-way glass panel application adjacent to doors
- Used when specifying 3-way centerline transitions
- Extends visual transparency between offices

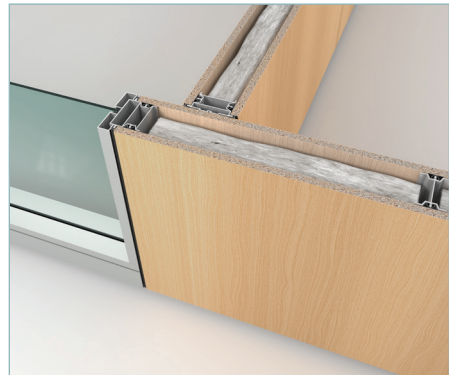

**OFF-MODULE**

- Allows for off-module 3-way connections
- Can only be used with solid face panels as shown

**GLASS 3-WAYS**

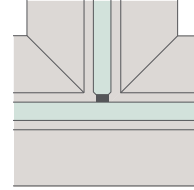

**3-WAY 90°  
2D CROSS SECTION**

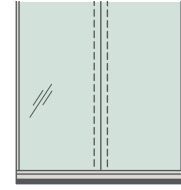

**3-WAY 90°  
2D ELEVATION**

**SYSTEM MODULE 3-WAYS**

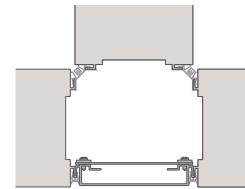

**3-WAY 90°**

**CENTERLINE 3-WAYS**

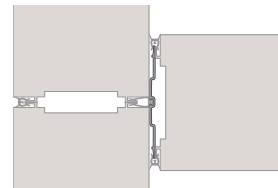

**3-WAY 90° CENTERLINE**

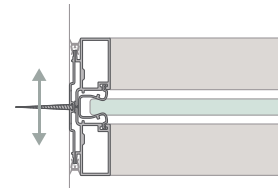

**OFF-MODULAR T-MOUNT**

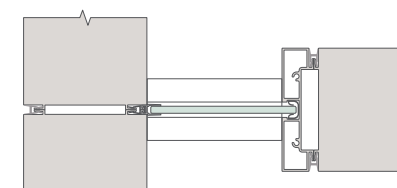

**FILLER FIN**

**TECHNICAL GUIDE**

TRANSITIONS: FRAMELESS GLASS 3-WAY

**ARCHITECTURAL OPTIONS**



**3-WAY GLAZING CONNECTOR, ENCLOSE**

- Extends visual transparency
- May be specified as silicone, polycarbonate, or bright metal

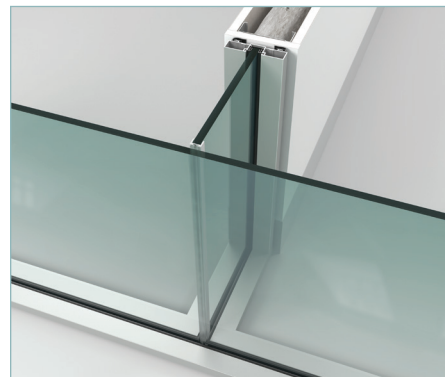

**3-WAY GLAZING CONNECTOR, DRYWALL**

- Extends visual transparency
- May be specified as silicone, polycarbonate, or bright metal

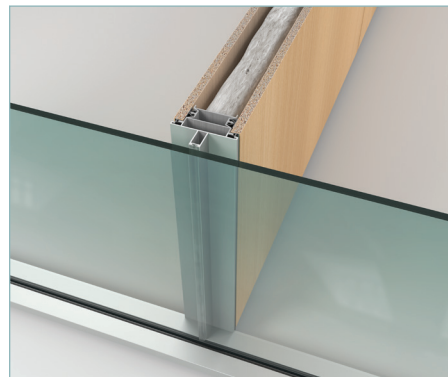

**FLY-BY POSTS**

- Off-modular interface with glass front
- Supports Enclose or base building returns
- Includes acoustic bulb seal

**90° GLAZING CONNECTORS**

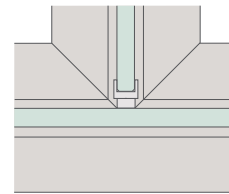

**3-WAY 90° TREATED METAL**

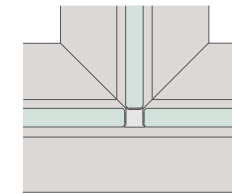

**3-WAY 90° PLASTIC**

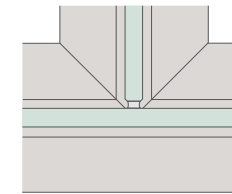

**3-WAY 90° SILICONE**

**VARIABLE ANGLE GLAZING CONNECTORS**

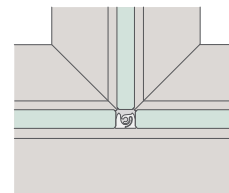

**3-WAY VARIABLE WITH POLISHED METAL CONNECTOR**

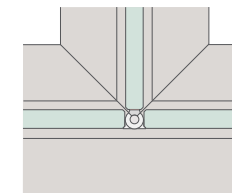

**3-WAY VARIABLE WITH PLASTIC CONNECTOR**

**FLY-BY POSTS**

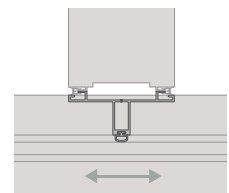

**FRAMELESS GLASS TO ENCLOSE**

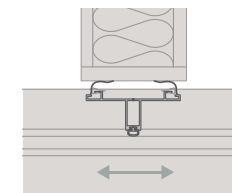

**FIXED IN PLACE**



**TECHNICAL GUIDE**

TRANSITIONS: FLY-BY + 4-WAY

**ARCHITECTURAL OPTIONS**

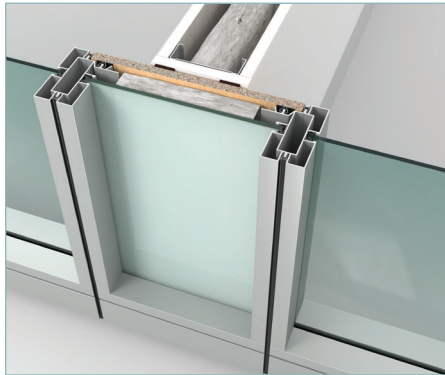

**INTERFACE PANEL**

- Backpainted center glazing panel to maintain glass panel run aesthetic
- Solid tile opposite side

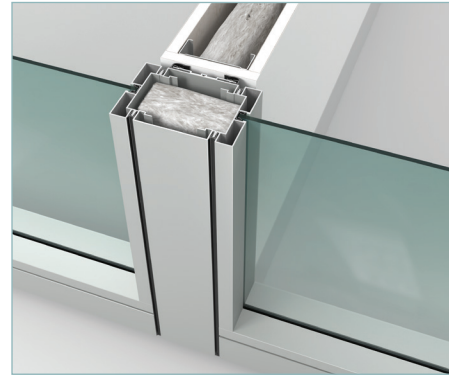

**INLINE POST**

- 4" x 4" or 4" x 6" (102 mm x 102 mm or 102 mm x 152 mm) transition post with acoustic and light seal
- May be specified with electrical knock-outs
- Can be finished in painted metal, wall covering, or wood

**GLASS FLY-BYS**

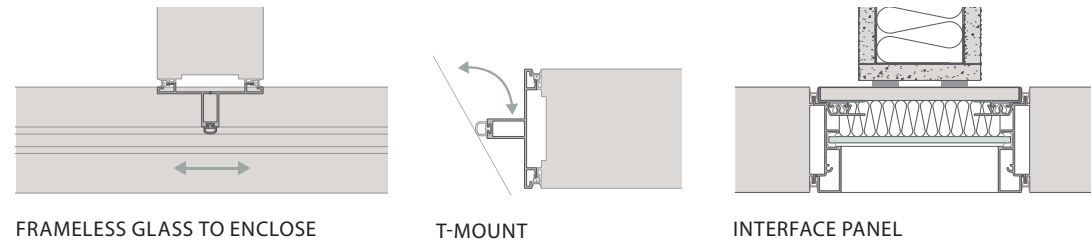

FRAMELESS GLASS TO ENCLOSE

T-MOUNT

INTERFACE PANEL

**SYSTEM MODULE FLY-BYS**

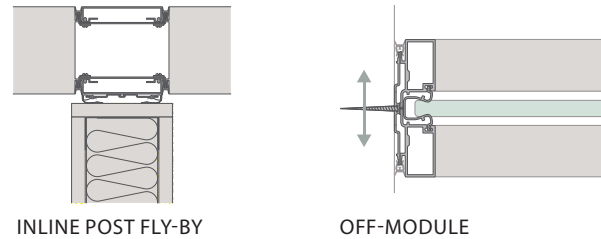

INLINE POST FLY-BY

OFF-MODULE

**4-WAY CONNECTIONS**

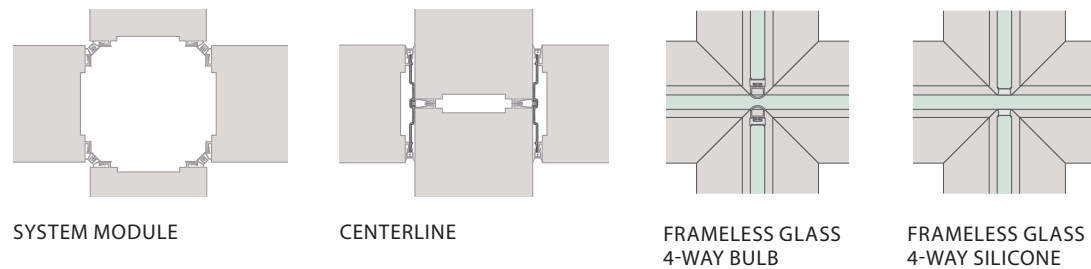

SYSTEM MODULE

CENTERLINE

FRAMELESS GLASS  
4-WAY BULB

FRAMELESS GLASS  
4-WAY SILICONE

**TECHNICAL GUIDE**

STARTERS + END OF RUNS

**ARCHITECTURAL OPTIONS**



**ADJUSTABLE STARTER**

- Spring-loaded adjustment shoe for easy base building connections
- +/- 1/2" (13 mm) of adjustment



**COMPRESSIBLE STARTER**

- The least visible starter
- Compresses to 5/16" (8 mm), expands to 1 1/8" (29 mm)



**END OF RUN POST**

- Finishes panel runs to create dividing walls
- Available in standard and low profiles
- Available in painted metal, wall covering, or veneer

**WALL STARTERS**

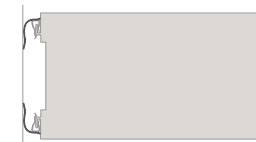

COMPRESSIBLE

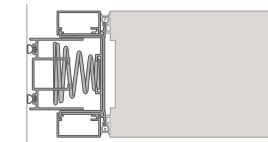

ADJUSTABLE



LOW PROFILE

**END OF RUNS**

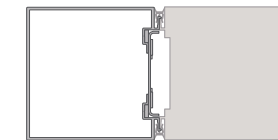

SYSTEM MODULE



LOW PROFILE

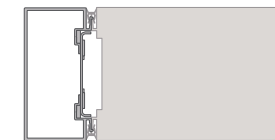

CENTERLINE



TECHNICAL GUIDE

DIMENSIONAL LOGIC: RAILS

TOP RAILS

BOTTOM RAILS

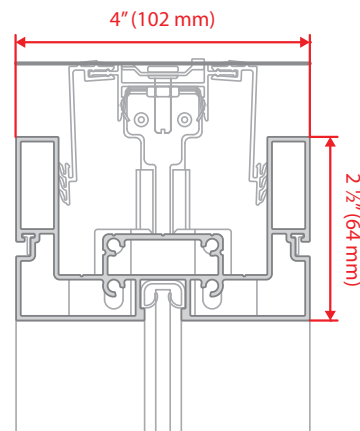

GLASS WALL  
TOP GLAZING RAIL

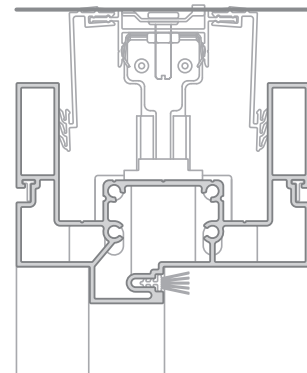

SWING DOOR FRAME  
HEADER

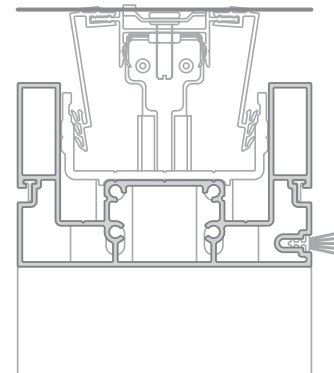

SLIDING DOOR FRAME  
HEADER

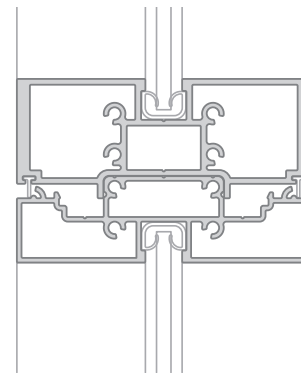

GLASS WALL  
TRANSOM RAIL

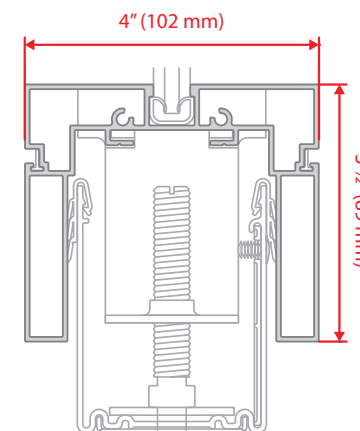

GLASS WALL  
BOTTOM GLAZING RAIL

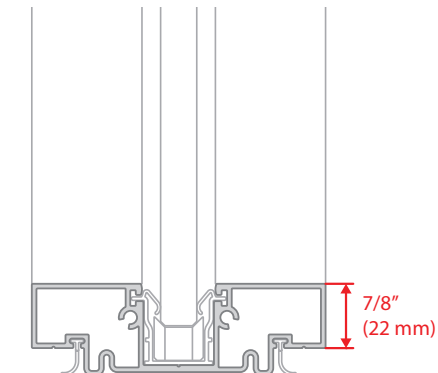

FRAMELESS GLASS  
BOTTOM GLAZING RAIL

VERTICAL RAILS

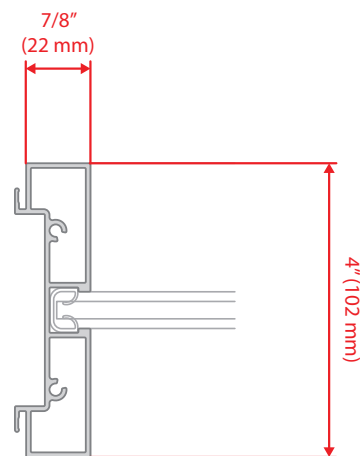

GLASS WALL  
GLAZING VERTICAL

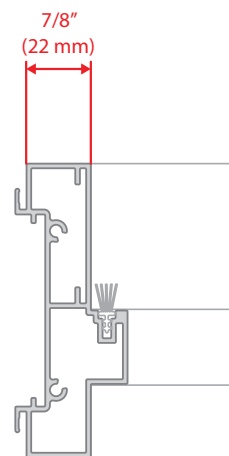

SWING DOOR  
DOOR FRAME JAMB

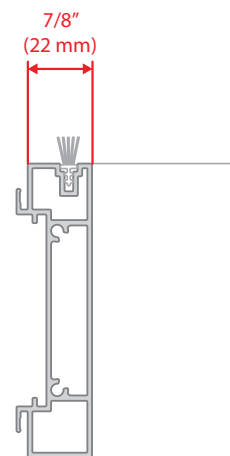

SLIDING DOOR  
DOOR FRAME JAMB

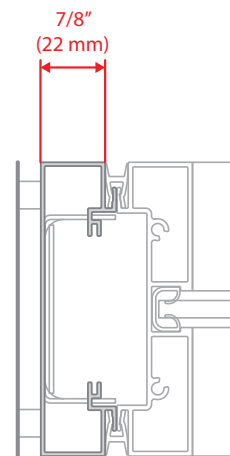

STARTER  
LOW PROFILE

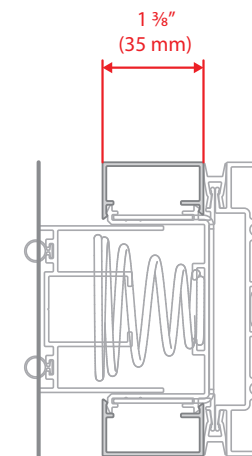

STARTER  
ADJUSTABLE

**TECHNICAL GUIDE**

**DIMENSIONAL LOGIC: REVEALS**

**TOP REVEALS**

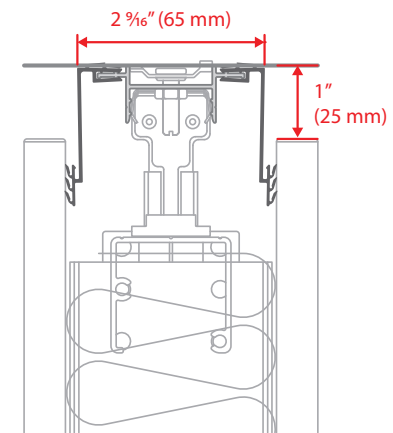

SOLID WALL  
CEILING REVEAL (NOMINAL)

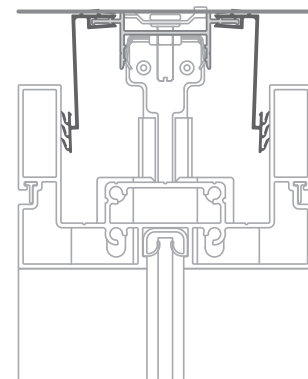

GLASS WALL  
CEILING REVEAL (NOMINAL)

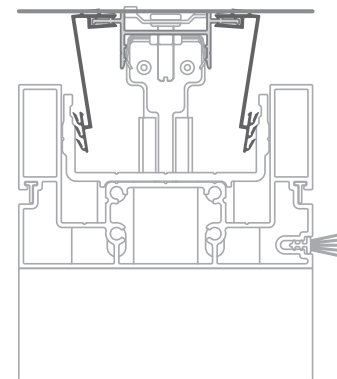

SWING DOOR FRAME  
CEILING REVEAL (NOMINAL)

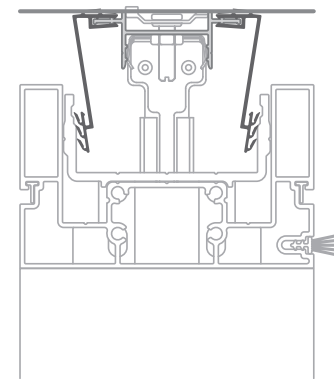

SLIDING DOOR FRAME  
CEILING REVEAL (NOMINAL)

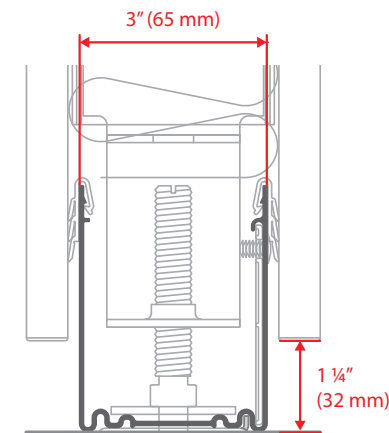

SOLID WALL  
FLOOR REVEAL (NOMINAL)

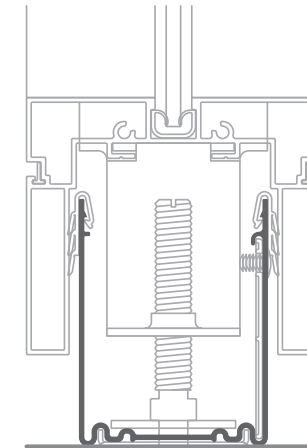

GLASS WALL  
FLOOR REVEAL (NOMINAL)

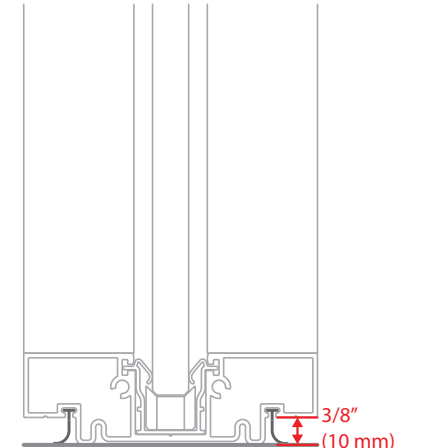

FRAMELESS GLASS  
FLOOR SHADOWGAP

**BOTTOM REVEALS**

**VERTICAL REVEALS**

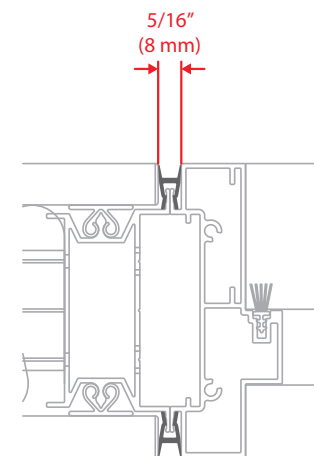

SOLID WALL TO SWING DOOR FRAME  
VERTICAL REVEAL

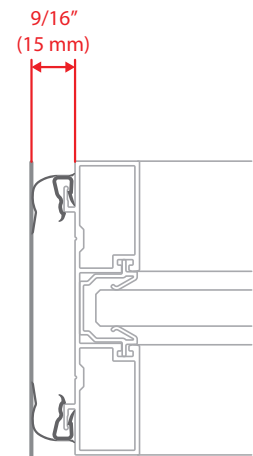

FRAMELESS GLASS TO  
COMPRESSIBLE STARTER  
VERTICAL REVEAL (NOMINAL)

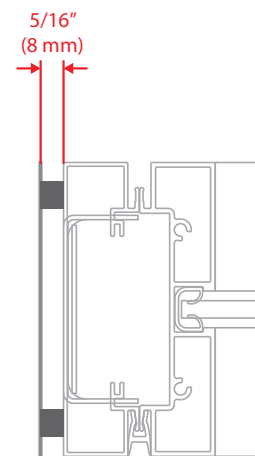

GLASS WALL TO  
LOW PROFILE STARTER  
VERTICAL REVEAL

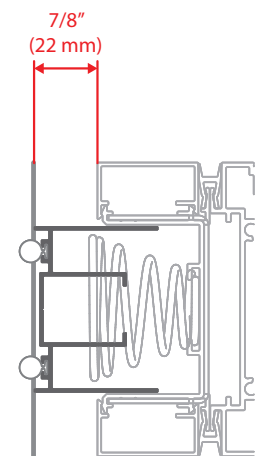

ADJUSTABLE STARTER TO  
SLIDING DOOR FRAME  
VERTICAL REVEAL (NOMINAL)



TECHNICAL GUIDE

STACK-ON PANELS

ARCHITECTURAL OPTIONS



FRAMELESS GLASS STACK

- Eliminates vertical framing



GLASS STACK-ON PANEL

- Accommodates varying ceiling heights by choosing base height and using stack-on panel for taller ceiling heights
- Simplifies delivery and handling by creating shorter panel height



SOLID STACK-ON PANEL

- Accommodates varying ceiling heights by choosing base height and using stack-on panel for taller ceiling heights
- Simplifies delivery and handling by creating shorter panel height

ELEVATIONS

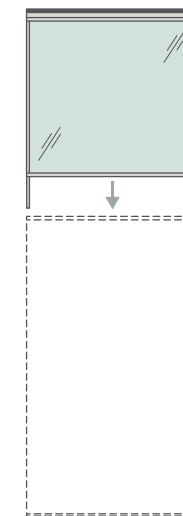

GLASS STACK-ON

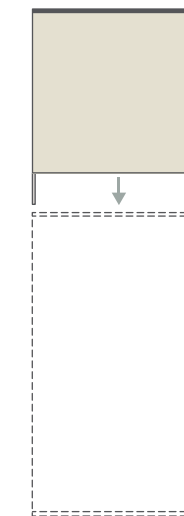

SOLID STACK-ON

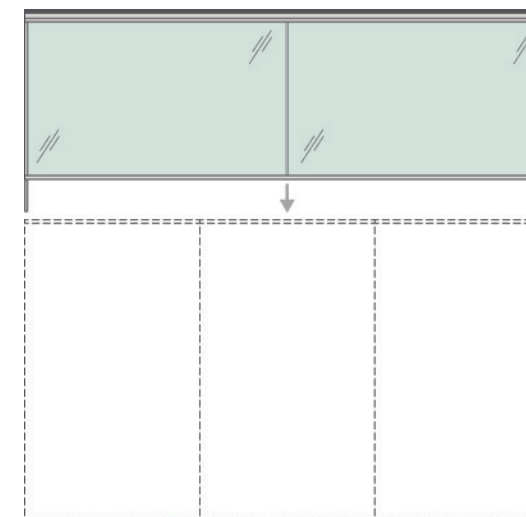

FRAMELESS GLASS TOPPER



PERFORMANCE



POWER BASE (PLUG + PLAY)

- Integrated plug + play electrical and data

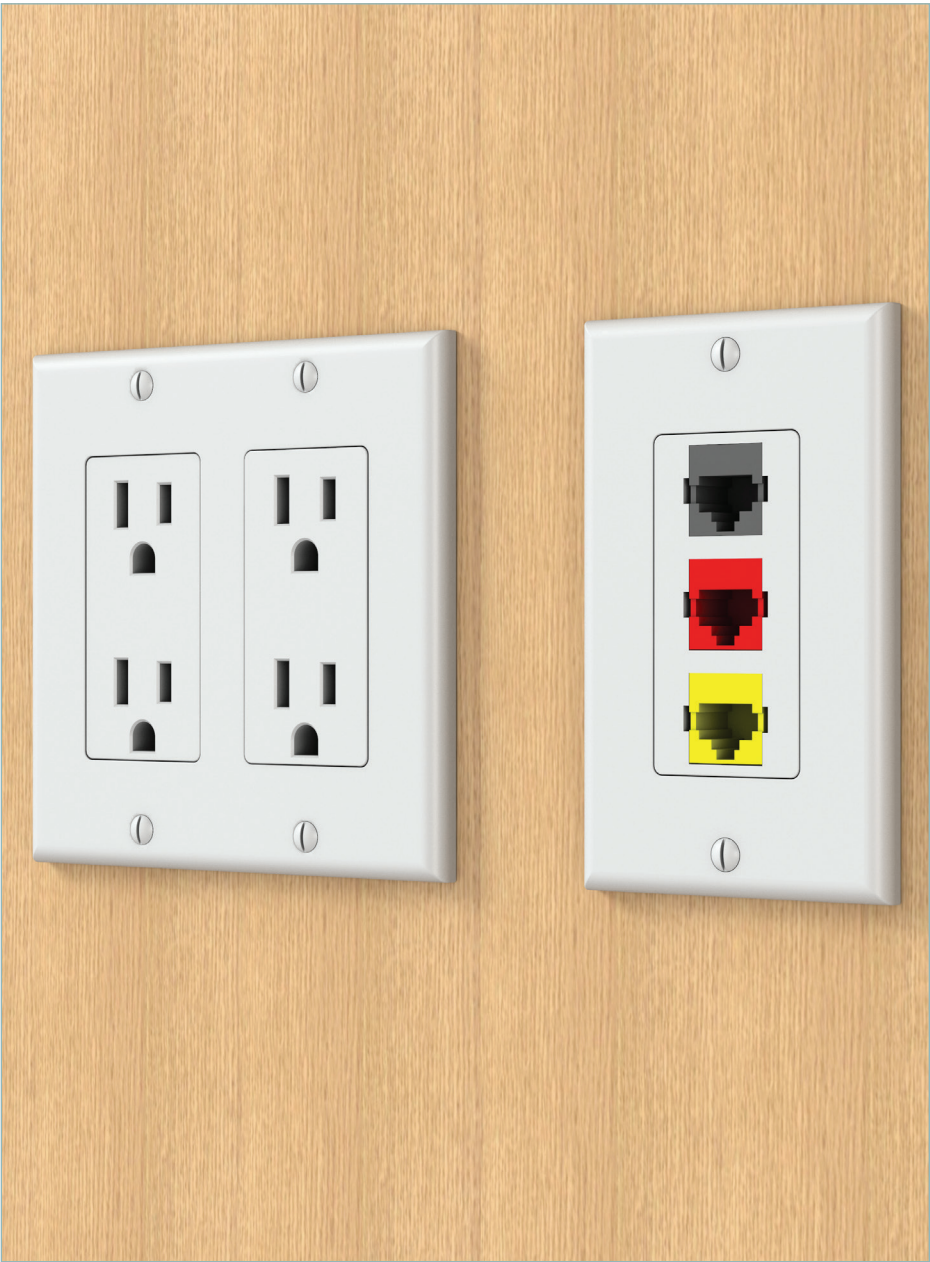

CONVENTIONAL

- Empty conduit/box for site installation
- Pre-wired for site connection



ELECTRICAL ROUTING

- Vertical from floor
- Horizontal through base



## FINISHES

Enclose walls were designed to stand alone or integrate within a holistic product platform to compound performance. As part of Haworth's Integrated Palette portfolio, Enclose walls can be combined with a wide range of desking, systems, tables, and other architectural products. Consistent dimensions, connections, and finishes future-proof your interiors, ensuring that Haworth products you choose today will function and fit aesthetically with the ones you add tomorrow.

Enclose walls are available in an array of finishes. Please visit [haworth.com/surfaces](http://haworth.com/surfaces) for a complete listing of material offering.



**FINISHES**

FRAMES + PANELS





FINISHES

FRAMES + PANELS







HAWORTH®

Haworth is a registered trademark of Haworth, Inc.  
Printed in USA ©Haworth, Inc 2015 05.18 Item # 5944  
haworth.com | eu.haworth.com | ap.haworth.com