

Haworth prices in this book will increase on October 1, 2018 by 4%

Beside® Storage

North America Price List / Specification Guide – April 2018



Electronic Update Page – Beside Storage Price List

- The table below lists all of the updates and addendums added to this price list since the original version was created.
- All **Update** pages will replace the existing pages within the document.
- All **New** pages will be placed at the back of the document.

Link	Date	Page	Description
Click Here	June 2018	347	Update – The Product Compatibility And Limited Warranty Policy Page was replaced with an updated version.
Click Here	June 2018	81	Update – A 20” long Jumper was added to the price list page (3 and 4 Circuit).
Click Here	October 2018	All	Update – Haworth prices in this book will increase on October 1, 2018 by 4%.



This Haworth North American price book contains US list prices. Canadian customers can convert the US list price into their Canadian equivalent by going to www.Haworth.com/Canada to find the current Canadian multipliers. These multiplier factors allow you to convert the US list price into a Canadian list price.

The following list gives a general overview of the content included within this price book (price list and specification guide) and explains how the book is organized and where information can be found.

- 1 Front Cover**
 - Includes the title and pricing effectivity date.
- 2 Electronic Update Page / Canadian Conversion**
 - Electronic versions of the Price Book (.pdf files) will include an Electronic Update Page listing the most recent updates and addendum added since the original version was created. If this section is blank no updates or addendums have been added.
 - Each update will include a description, page number, date and a link to the updated or new page.
 - The footer contains Canadian conversion information for converting US pricing into the Canadian equivalent.
- 3 Table of Contents**
 - Price List content with page numbers.
- 4 Price List**

Each price list page contains the following:

 - Product Illustration
 - Catalog Number
 - To Order Specify – sequencing for ordering product options and finishes
 - List Prices
 - Product Specification Dimensions
 - Features
 - Specification Tips
 - Class, Discount Group Number (used for discounting) and GSA information
- 5 Specification Guide**
 - Table of Contents – specification guide content with page numbers
 - Statement of Line – provides a pictorial outline of the product offering
 - Product Overview – brief introduction of the product and application intent
 - Easy Planning Steps – basic steps of planning with the product line
 - Product Details – product attributes, dimensions, surface materials and functionality
 - Product Application – vertical and horizontal planning guidelines including support and load, power, and storage
 - Technical Specifications – provides performance ratings, material composition and manufacturing process information
- 6 Finishes, Fabrics and COM**
 - Lists information for material finishes and availability.
 - Provides COM information and requirements (if applicable).
- 7 North American Terms of Sale**
 - Haworth terms for ordering, pricing, shipping and delivery, general terms, and services.
- 8 Index**
 - Products are listed alphabetically by alpha-numeric catalog numbers with price list page number.
- 9 Product Non-Obsolescence and Warranty Policy**
 - Provides Haworth policy for non-obsolescence and warranty.

Additional Information and Resources

Prices are subject to change without notice or approval. Haworth dealers should always submit proposals through Lynx before presenting to customers. See North American Terms of Sale for more information.

Online Resources

haworth.com

- Haworth's corporate website provides access to price books and a variety of other resources and publications.

surfaces.haworth.com

- Website provides access to the most current fabrics and finishes offered across Haworth's various product lines.

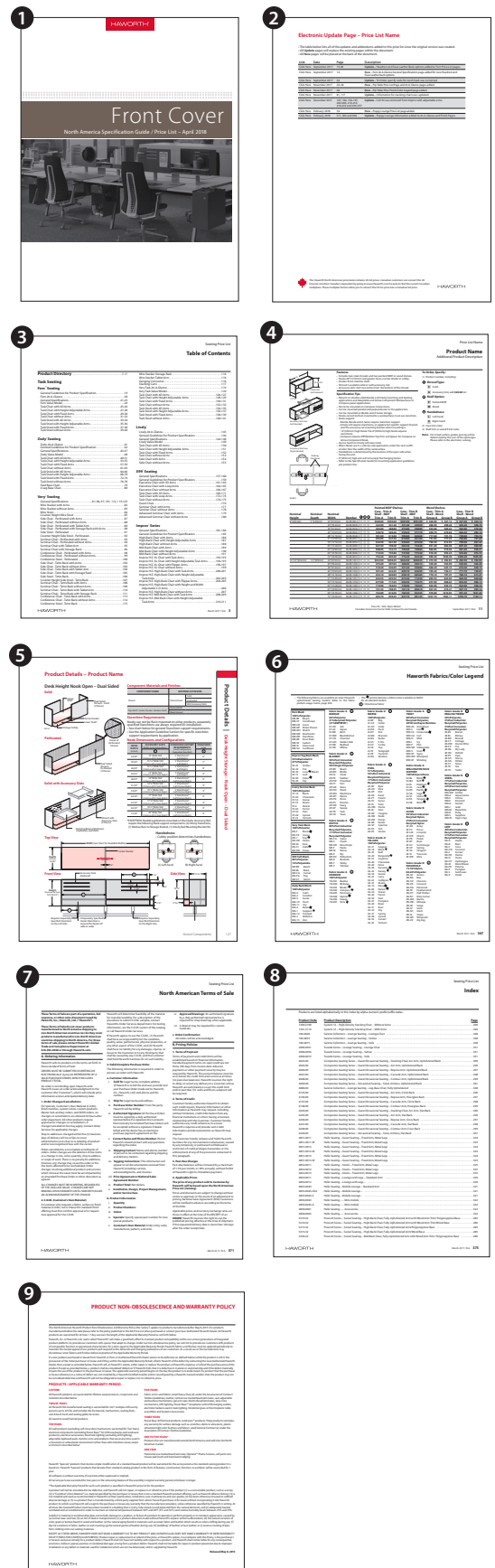

Table of Contents

Beside Storage

Catalog Logic	5-8
---------------------	-----

Base Unit

Open	10
Open Storage with a Drawer — Single	12
Open Storage with a Drawer — Double	18
Drawer Combinations — Single	26
Drawer Combinations — Double	30
Drawer Combinations — Triple	35
Hinged Door	38
Hinged Door — Open Storage Unit	45
Hinged Door — Drawer Combination	51
Single Sliding Door	59
Double Sliding Door	63

Storage Top

Rectangular	66
-------------------	----

Finished Back

Finished Back	67
---------------------	----

Accessories — Base Unit Accessory Shelf

Single Units — Open and Functional	68
Double Units — Open/Open	68
Double Units — Open/Functional	68
Single Sliding Door	69
Double Sliding Door	69
Triple Unit	70

Accessories

Filler Panel	71
Top Filler Track	71
Storage to Panel Bracket	72
Adaptable Anti-Dislodgement Clip Kit	72
Desk-to-Storage Bracket	73
Storage Attachment Bracket	73
Flush Mount Plate	73
Ganging Bracket Kit	74
Front-to-Back Hanging Bars	74
Cushion	75
Counterweight	75

Electrical Components

Infeed Harness	76
Internal Power Base™ AI Base Feed	77
Base Feed Module — Architectural Concealed — Hardwire Connection	78
Top Feed — Beside Storage Only	79
Top Feed Grommet — Beside Storage Only	79
Power Distribution Assembly — Beside Storage Only	80
Jumpers	81
Top Feed — Hardwire Beside Storage Only	82
Top Feed Grommet — Beside Storage Only	82
Hardwire Kit — Beside Storage Only	82
Patch Cord Data Holder Bracket	83
Modular Furniture Telecommunication Opening	83

Stanchion Kit and Overhead Storage Unit

Stanchion Kits and Accessories

Stanchion Kit — G	84
Stanchion Kit — H	85
Stanchion Kit — M	87
Stanchion Kit — N	91

Stanchion Kit — P	94
Stanchion Kit — Q	100

Overhead Storage Unit and Overhead Storage Unit Accessories

Hutch Shelf	104
Overhead Storage Unit — Single Sided Open	105
Overhead Storage Unit — Single Sided Hinged Doors	107
Overhead Storage Unit — Single Sided Hinged Doors	111
Overhead Storage Unit — Single Sided Sliding Doors	115
Overhead Storage Unit — Single Sided Sliding Doors	119
Dual Sided Open	122
Dual Sided Sliding Doors	124
Dual Sided Sliding Doors	126
Top Mount Bracket	128
Off Modular Top Trim Mounting 18"-120" for Compose	128
Ganging Tie Plate Bracket	129

Task Lighting

Adaptable Electronic Ballast Task Light	130
Adaptable Light Skirt	130

Belong Screens

Screen — Back	132
Screen — Center	134
Bracket — Screen — For use with 120° Reside worksurface	135

Storage Pantry

28" High	136
Laminate Case and Front	138
Laminate Case with Wood Front	140
Wood Case with Laminate Front	142
Wood Case with Wood Front	144
Storage Pantry Finished Back	146

Pantry Accessories

Personal Drawer	147
Hanging File Drawer	147
Adjustable Shelf	147
Upper Slat Rail	148
Lower Slat Rail	148
Saddle	148
Attachment Brackets	149
Compose Panel to Pantry Bracket	150

Electrical Components

Bezel Utility Model	151
Jumpers	152
Grommet	152

Finishes and Fabrics

Fabrics/Color Legend	333
Vertical Fabrics/Color Legend	334-335
Seating Fabrics/Color Legend	336-337

Customer's Own Material

COM Yardage Requirements	338-339
--------------------------------	---------

Terms of Sale

North American	340-343
----------------------	---------

Index

.....	344-346
-------	---------

Lifetime Product Warranty

.....	Inside Back Cover
-------	-------------------

Base Unit — Catalog Logic

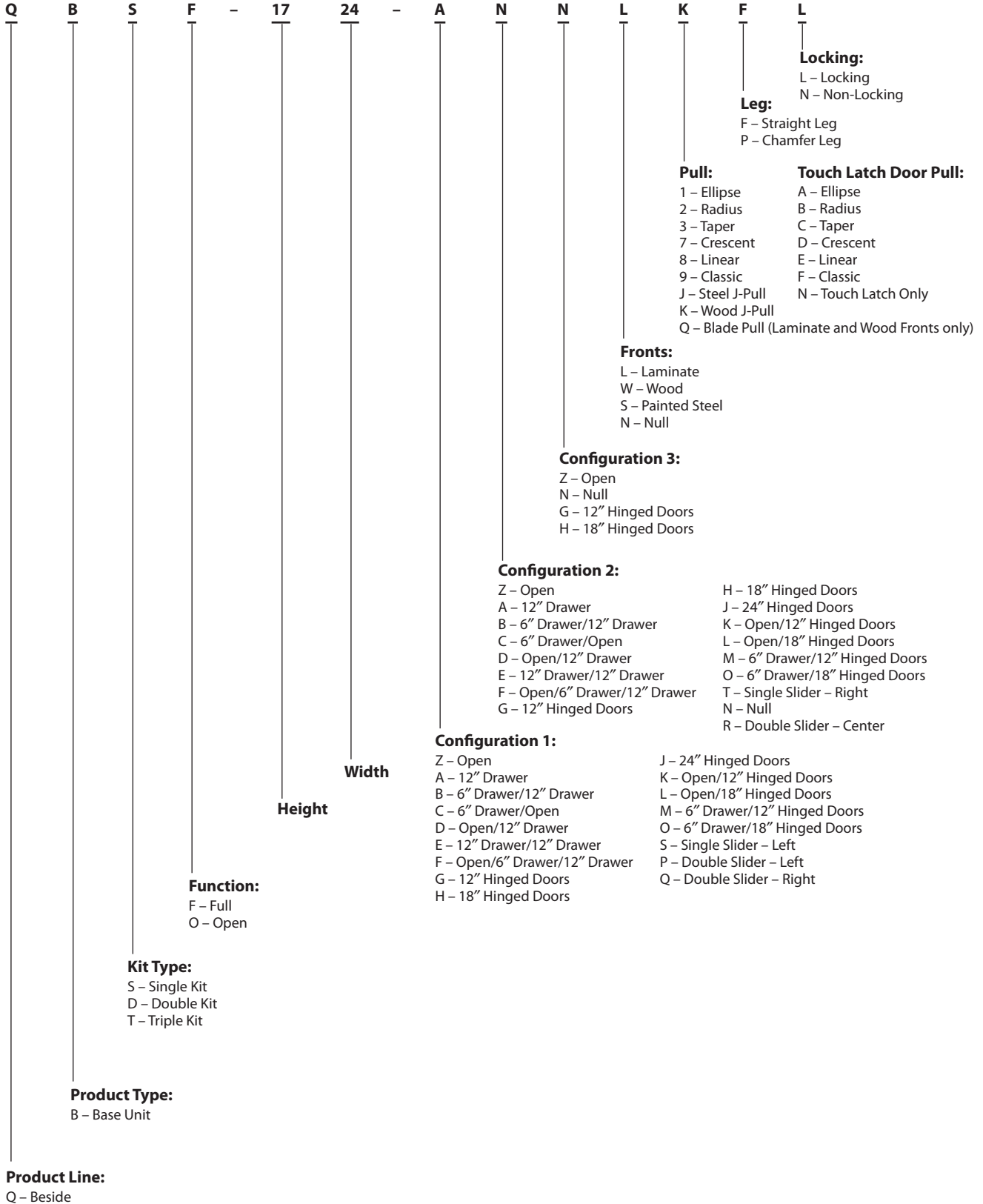

Overhead Storage Unit – Catalog Logic

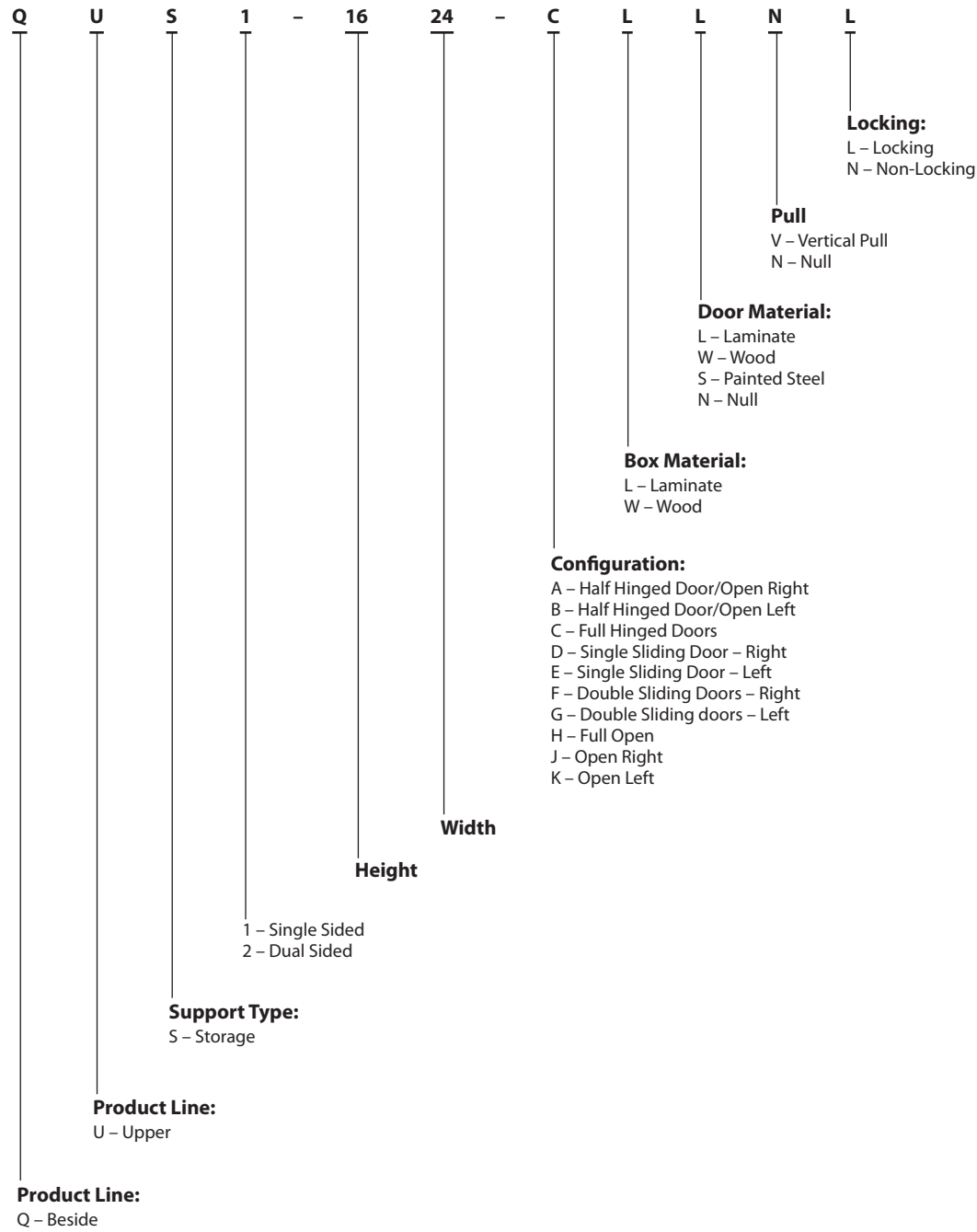

Stanchion — Catalog Logic

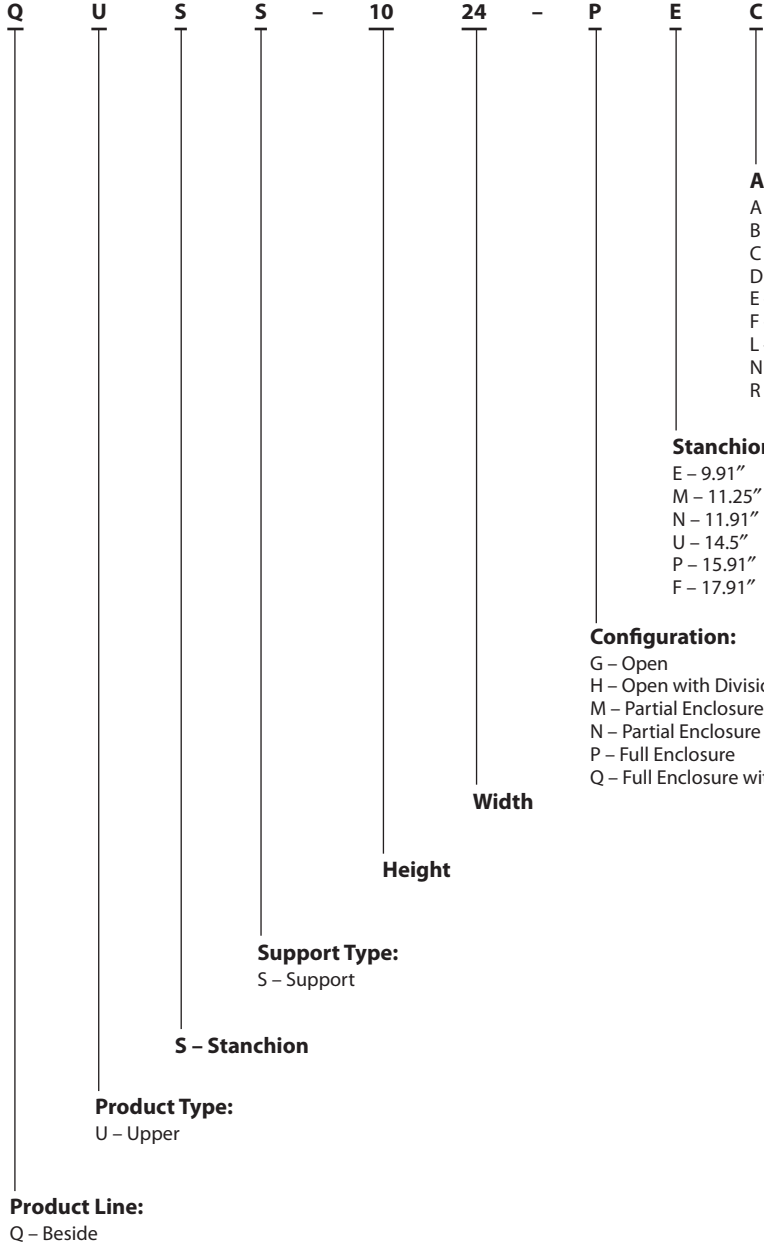

Accessory Functionality:
 A – User sided accessory slot for right hand stanchion
 B – User sided accessory slot for left hand stanchion
 C – User sided accessory slot for right and left hand stanchion
 D – Both side accessory slot for right hand stanchion
 E – Both side accessory slot for left hand stanchion
 F – Both sided accessory slot for right and left hand stanchion
 L – No accessory slots left
 N – No Slots
 R – No accessory slots right

Stanchion Height:
 E – 9.91”
 M – 11.25”
 N – 11.91”
 U – 14.5”
 P – 15.91”
 F – 17.91”

Configuration:
 G – Open
 H – Open with Division
 M – Partial Enclosure
 N – Partial Enclosure with Division
 P – Full Enclosure
 Q – Full Enclosure with Division

Width

Height

Support Type:
S – Support

S – Stanchion

Product Type:
U – Upper

Product Line:
Q – Beside

Hutch Shelf — Catalog Logic

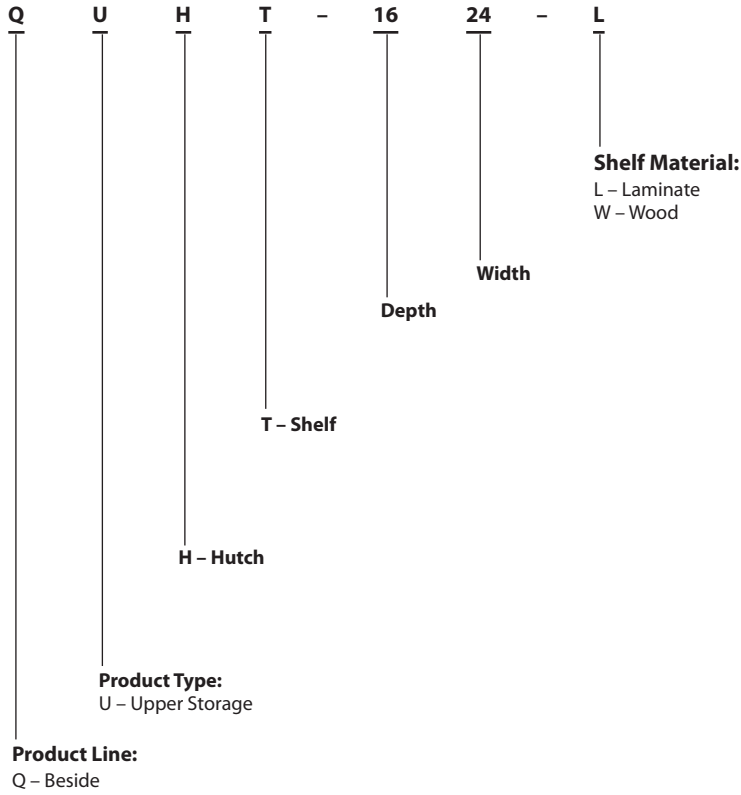

This page intentionally blank

Base Unit — Open Storage

Open

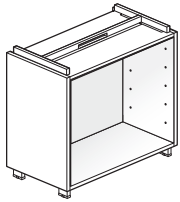
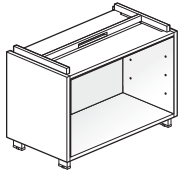
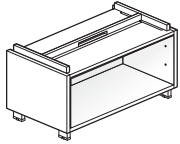

QB50

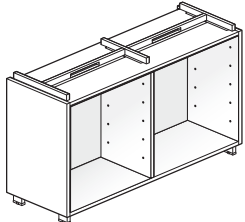
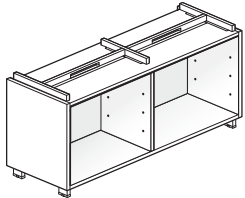
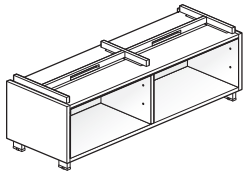

QBDO

Features

- Storage units without doors include:
 - Laminate end panel and inner top.
 - Painted Steel inner back and bottom.
 - Painted Steel spacer.
- Leg Options:
 - Straight Leg (F)
 - Chamfer Leg (P)
- Glide adjustment range:
 - Straight Leg: 1.5”(38mm)
 - Chamfer Leg: 1.25”(32mm)
- Spacer:
 - 1.18”(30mm) high
 - End pieces come in specified color; center spacer section black only.
- Case ships assembled. Legs require field installation.

Specification Tips

- Designed to be used with Haworth's Integrated Palette, UniGroup Too, PREMISE, Reside Desking and/or Belong Work Tools.
- Beside base units 24”-42”(610mm-1067mm) cannot be freestanding. Units must be attached or ganged together.
- All base units with drawers must be attached. Refer to Specification Guide for planning information.
- Beside base units 48”-72”(1219mm-1829mm) widths can be freestanding.
- Separately specified storage tops are required and can match the width of a single base unit or span two or more adjacent base units side by side.
- To route and access power in storage, order separately specified Belong power components.
- 1.5H and 2H storage can be used to support Reside desking or Adaptable worksurface in a perpendicular configuration with separately specified brackets. Refer to Specification Guide for planning information.
- Beside base storage unit with top, spacer, base unit and legs finished heights:
 - 1H = 17”(432mm)
 - 1.5H = 23”(584mm)
 - 2H = 29”(737mm)
- Separately specified if applicable:
 - Belong Power and communication cabling, tools, screens and tool rails.
 - Storage-to-Panel Bracket
 - Storage Attachment Bracket
 - Ganging Bracket
 - Storage Top (required)
 - Filler Panel
 - Top Filler Track
 - Finished Back (recommended when back is exposed)
 - Adjustable Shelf (not included with unit)
 - Stack-On Hutch
- Refer to Specification Guide for planning information and actual dimensions.

Notes: 2H storage base units are not designed to fit under Reside benching or return worksurfaces. Reside Desking or Adaptable worksurfaces can be attached to the front or back of a 2H Beside storage unit with separately specified flush mount plates.

Separately specified Belong base unit power components available for 30”-72”(762mm-1067mm) widths only.

Storage shelves are unique to the specific base unit configuration. Refer to shelf price list pages for appropriate shelf.

1H units cannot accept binders.

To Order, Specify:

- Product number, including:

1 Leg Option:

- F** Straight Leg
- P** Chamfer Leg, add **\$85.70** list

- Case laminate color.
- Case laminate edgeband.
- Bottom and inset back trim.
- Leg and spacer end trim color.

Note: Upcharge for mixed grade fabric or trim surfaces, refer to the electronic design and specification tools for pricing.

Base Unit — Open Storage

Description	Finished Height*	Actual Width	Nominal Width	Number	①	Case Laminate A		Case Laminate B		
						Trim A	Trim B	Trim A	Trim B	
Single — 1H										
	17"(432mm)	23 7/8"(606mm)	24"(610mm)	QBSO-1724-ZNNNN	■	N	\$531.32	\$545.25	\$ 573.10	\$ 587.03
		29 7/8"(759mm)	30"(762mm)	QBSO-1730-ZNNNN	■	N	559.17	575.24	603.09	619.16
		35 7/8"(911mm)	36"(914mm)	QBSO-1736-ZNNNN	■	N	587.02	605.23	633.08	651.29
		41 7/8"(1064mm)	42"(1067mm)	QBSO-1742-ZNNNN	■	N	614.87	635.22	663.07	683.42
Single — 1.5H										
	23"(584mm)	23 7/8"(606mm)	24"(610mm)	QBSO-2324-ZNNNN	■	N	\$619.16	\$637.37	\$ 667.36	\$ 685.57
		29 7/8"(759mm)	30"(762mm)	QBSO-2330-ZNNNN	■	N	647.01	667.36	697.35	717.70
		35 7/8"(911mm)	36"(914mm)	QBSO-2336-ZNNNN	■	N	674.86	697.35	727.34	749.83
		41 7/8"(1064mm)	42"(1067mm)	QBSO-2342-ZNNNN	■	N	702.71	727.34	757.33	781.96
Single — 2H										
	29"(737mm)	23 7/8"(606mm)	24"(610mm)	QBSO-2924-ZNNNN	■	N	\$707.00	\$729.50	\$ 761.63	\$ 784.13
		29 7/8"(759mm)	30"(762mm)	QBSO-2930-ZNNNN	■	N	734.85	759.49	791.62	816.26
		35 7/8"(911mm)	36"(914mm)	QBSO-2936-ZNNNN	■	N	762.70	789.48	821.61	848.39
		41 7/8"(1064mm)	42"(1067mm)	QBSO-2942-ZNNNN	■	N	790.55	819.47	851.60	880.52
Double — 1H										
	17"(432mm)	47 7/8"(1216mm)	48"(1219mm)	QBDO-1748-ZZNNN	■	N	\$642.72	\$665.21	\$ 693.06	\$ 715.55
		59 7/8"(1521mm)	60"(1524mm)	QBDO-1760-ZZNNN	■	N	698.42	725.19	753.04	779.81
		71 7/8"(1826mm)	72"(1829mm)	QBDO-1772-ZZNNN	■	N	754.12	785.17	813.02	844.07
Double — 1.5H										
	23"(584mm)	47 7/8"(1216mm)	48"(1219mm)	QBDO-2348-ZZNNN	■	N	\$730.56	\$757.33	\$ 787.32	\$ 814.09
		59 7/8"(1521mm)	60"(1524mm)	QBDO-2360-ZZNNN	■	N	786.26	817.31	847.30	878.35
		71 7/8"(1826mm)	72"(1829mm)	QBDO-2372-ZZNNN	■	N	841.96	877.29	907.28	942.61
Double — 2H										
	29"(737mm)	47 7/8"(1216mm)	48"(1219mm)	QBDO-2948-ZZNNN	■	N	\$818.40	\$849.46	\$ 881.59	\$ 912.65
		59 7/8"(1521mm)	60"(1524mm)	QBDO-2960-ZZNNN	■	N	874.10	909.44	941.57	976.91
		71 7/8"(1826mm)	72"(1829mm)	QBDO-2972-ZZNNN	■	N	929.80	969.42	1001.55	1041.17

*Finished height is for fully assembled base unit including separately specified top.

Base Unit — Open Storage with a Drawer — Single

Open Storage with a Drawer — Single

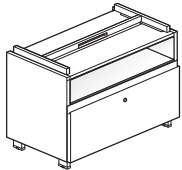
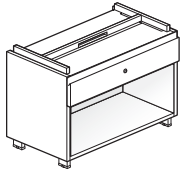

Q85F-2330

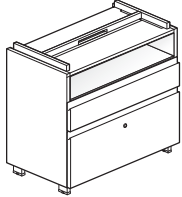
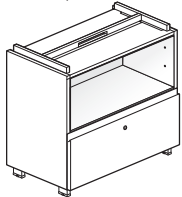
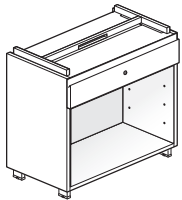

Q85F-2930

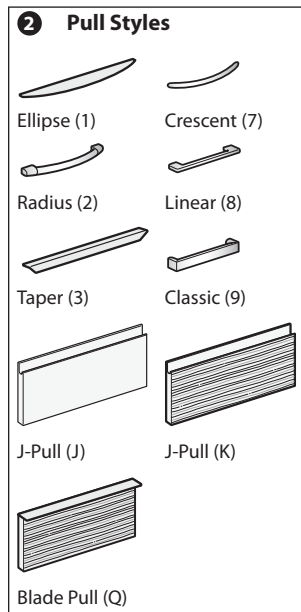

Features

- Open Storage with a drawer include:
 - Laminate end panel and inner top.
 - Painted Steel inner back and bottom.
 - Painted Steel spacer.
- Leg Options:
 - Straight Leg (F)
 - Chamfer Leg (P)
- Glide adjustment range:
 - Straight Leg: 1.5”(38mm)
 - Chamfer Leg: 1.25”(32mm)
- Spacer:
 - 1.18”(30mm) high
 - End pieces come in specified color; center spacer section black only.
- Drawer interior is black.
- Drawer front options include painted steel, laminate or wood.
- Lateral file includes side-to-side filing bar.
- Full extension drawers.
- Ellipse pull available in non-metallic color only. (see finish page for pull color)
- Radius pull available in metallic colors only. (see finish page for pull color)
- J-Pull (J) matches painted steel fronts.
- J-Pull (K) or Blade Pull (Q) available on laminate or wood fronts only. Must specify color.
- Lock Options:
 - Locking (chrome only) and non-locking available.
 - One lock accommodates all drawers.
- Shelves are separately specified; not included with unit.
- Case ships assembled. Legs require field installation.

Specification Tips

- Designed to be used with Haworth's Integrated Palette, UniGroup Too, PREMISE, Reside Desking and/or Belong Work Tools.
- All base units with drawers must be attached. Refer to Specification Guide for planning information.
- Separately specified storage tops are required and can match the width of a single base unit or span two or more adjacent base units side by side.
- To route and access power in storage, order separately specified Belong power components.
- 1.5H and 2H storage can be used to support Reside desking or Adaptable worksurfaces in a perpendicular configuration with separately specified brackets. Refer to Specification Guide for planning information.
- Beside base storage unit with top, spacer, base unit and legs finished heights:
 - 1H = 17”(432mm)
 - 1.5H = 23”(584mm)
 - 2H = 29”(737mm)
- Separately specified if applicable:
 - Belong Power and communication cabling, tools, screens and tool rails.
 - Storage-to-Panel Bracket
 - Storage Attachment Bracket
 - Ganging Bracket
 - Storage Top (required)
 - Filler Panel
 - Top Filler Track
 - Finished Back (recommended when back is exposed)
 - Adjustable Shelf (not included with unit)
 - Stack-On Hutch
 - Front-to-Back Filing Bar
- Refer to Specification Guide for planning information and actual dimensions.

Notes: 2H storage base units are not designed to fit under Reside benching or return worksurfaces. Reside Desking or Adaptable worksurfaces can be attached to the front or back of a 2H Beside storage unit with separately specified flush mount plates.

Separately specified Belong base unit power components available for 30”-72”(372mm-1829mm) widths only.

Storage shelves are unique to the specific base unit configuration. Refer to shelf price list pages for appropriate shelf.

To Order, Specify:

Steel Drawer Front

1) Product number, including:

1 Steel Drawer Front Option:

S Steel

2 Pull Option: (see side bar)

3 Leg Option:

F Straight Leg

P Chamfer Leg, add **\$85.70** list

4 Lock Option:

L Locking, add **\$42.85** list

N Non-Locking

2) Case laminate color.

3) Case laminate edgeband color.

4) Bottom, inset back and fixed shelf trim color.

5) Pull, leg and spacer trim color.

6) Drawer front steel color.

Laminate or Wood Drawer Front

1) Product number, including:

1 Laminate or Wood Drawer Front Option:

L Laminate

W Wood

2 Pull Option: (see side bar)

3 Leg Option:

F Straight Leg

P Chamfer Leg, add **\$85.70** list

4 Lock Option:

L Locking, add **\$42.85** list

N Non-Locking

2) Case laminate color.

3) Case laminate edgeband color.

4) Bottom, inset back and fixed shelf trim color.

5) Pull, leg and spacer trim color.

6) Drawer front laminate or wood color.

7) Laminate drawer front edgeband color.

Note: Upcharge for mixed grade fabric or trim surfaces, refer to the electronic design and specification tools for pricing.

Base Unit — Open Storage with a Drawer — Single

Description	Finished Height*	Actual Width	Nominal Width	Pull	Number	Case Laminate A				Laminate Door		Wood Door							
						Steel Door Trim A	Trim B	A	B	Group A	Group B								
Single 1.5H																			
Box Drawer/ 12" Open	23"(584mm)	23 7/8"(606mm)	24"(610mm)	1, J	QBSF-2324-CNN	1	2	3	4	\$ 904.10	\$ 915.88	\$1021.93	\$1064.78	\$1230.82	\$1273.67				
						2,3	QBSF-2324-CNN					930.88	942.66	1048.71	1091.56	1257.60	1300.45		
						7,8,9	QBSF-2324-CNN					936.24	948.02	1054.07	1096.92	1262.96	1305.81		
						K	QBSF-2324-CNN	K				N/A	N/A	1086.20	1129.05	1295.09	1337.94		
					Q	Q	Q			N/A	N/A	1118.34	1161.19	1327.23	1370.08				
						29 7/8"(759mm)	30"(762mm)	1, J	QBSF-2330-CNN					\$ 954.45	\$ 968.37	\$1081.92	\$1127.98	\$1310.09	\$1358.30
						2,3	QBSF-2330-CNN					981.23	995.15	1108.70	1154.76	1336.87	1385.08		
						7,8,9	QBSF-2330-CNN					986.59	1000.51	1114.06	1160.12	1342.23	1390.44		
					K	QBSF-2330-CNN	K			N/A	N/A	1146.19	1192.25	1374.36	1422.57				
						Q	QBSF-2330-CNN	Q			N/A	N/A	1178.33	1224.39	1406.50	1454.71			
						35 7/8"(911mm)	36"(914mm)	1, J	QBSF-2336-CNN					\$1004.80	\$1020.86	\$1141.91	\$1191.18	\$1389.36	\$1442.93
						2,3	QBSF-2336-CNN					1031.58	1047.64	1168.69	1217.96	1416.14	1469.71		
					7,8,9	QBSF-2336-CNN				1036.94	1053.00	1174.05	1223.32	1421.50	1475.07				
						K	QBSF-2336-CNN	K			N/A	N/A	1206.18	1255.45	1453.63	1507.20			
						Q	QBSF-2336-CNN	Q			N/A	N/A	1238.32	1287.59	1485.77	1539.34			
						6" Open/ Lateral File	23"(584mm)	23 7/8"(606mm)	24"(610mm)	1, J	QBSF-2324-DNN				\$1199.75	\$1211.53	\$1317.58	\$1360.43	\$1526.47
					2,3	QBSF-2324-DNN				1226.53	1238.31	1344.36	1387.21	1553.25	1596.10				
						7,8,9	QBSF-2324-DNN					1231.89	1243.67	1349.72	1392.57	1558.61	1601.46		
						K	QBSF-2324-DNN	K			N/A	N/A	1381.85	1424.70	1590.74	1633.59			
						Q	QBSF-2324-DNN	Q			N/A	N/A	1413.99	1456.84	1622.88	1665.73			
					29 7/8"(759mm)	30"(762mm)	1, J	QBSF-2330-DNN					\$1274.73	\$1288.65	\$1402.20	\$1448.26	\$1630.37	\$1678.58	
						2,3	QBSF-2330-DNN					1301.51	1315.43	1428.98	1475.04	1657.15	1705.36		
						7,8,9	QBSF-2330-DNN					1306.87	1320.79	1434.34	1480.40	1662.51	1710.72		
						K	QBSF-2330-DNN	K			N/A	N/A	1466.47	1512.53	1694.64	1742.85			
					Q	QBSF-2330-DNN	Q			N/A	N/A	1498.61	1544.67	1726.78	1774.99				
						35 7/8"(911mm)	36"(914mm)	1, J	QBSF-2336-DNN					\$1349.71	\$1365.77	\$1486.82	\$1536.09	\$1734.27	\$1787.84
						2,3	QBSF-2336-DNN					1376.49	1392.55	1513.60	1562.87	1761.05	1814.62		
						7,8,9	QBSF-2336-DNN					1381.85	1397.91	1518.96	1568.23	1766.41	1819.98		
					K	QBSF-2336-DNN	K			N/A	N/A	1551.09	1600.36	1798.54	1852.11				
						Q	QBSF-2336-DNN	Q			N/A	N/A	1583.23	1632.50	1830.68	1884.25			

*Finished Height includes worksurface top, spacer, base unit and legs

Base Unit — Open Storage with a Drawer — Single

Description	Finished Height*	Actual Width	Nominal Width	Pull	Number	Case Laminate A				Steel Door Trim A	Steel Door Trim B	Laminate Door A	Laminate Door B	Wood Door Group A	Wood Door Group B
						①	②	③	④						
Single 2H															
Box Drawer/ 18" Open	29"(737mm)	23 7/8"(606mm)	24"(610mm)	1, J	QBSF-2924-CNN	■ ■ ■ ■	\$1039.07	\$1055.14	\$1167.61	\$1210.46	\$1397.92	\$1440.77			
						2,3	QBSF-2924-CNN	■ ■ ■ ■	1065.85	1081.92	1194.39	1237.24	1424.70	1467.55	
						7,8,9	QBSF-2924-CNN	■ ■ ■ ■	1071.21	1087.28	1199.75	1242.60	1430.06	1472.91	
						K	QBSF-2924-CNN	■ K ■ ■	N/A	N/A	1231.88	1274.73	1462.19	1505.04	
Q	QBSF-2924-CNN	■ Q ■ ■	N/A	N/A	1264.02	1306.87	1494.33	1537.18							
	29 7/8"(759mm)	30"(762mm)	1, J	QBSF-2930-CNN	■ ■ ■ ■	\$1096.91	\$1115.12	\$1235.09	\$1281.15	\$1484.68	\$1532.89				
					2,3	QBSF-2930-CNN	■ ■ ■ ■	1123.69	1141.90	1261.87	1307.93	1511.46	1559.67		
					7,8,9	QBSF-2930-CNN	■ ■ ■ ■	1129.05	1147.26	1267.23	1313.29	1516.82	1565.03		
					K	QBSF-2930-CNN	■ K ■ ■	N/A	N/A	1299.36	1345.42	1548.95	1597.16		
Q	QBSF-2930-CNN	■ Q ■ ■	N/A	N/A	1331.50	1377.56	1581.09	1629.30							
	35 7/8"(911mm)	36"(914mm)	1, J	QBSF-2936-CNN	■ ■ ■ ■	\$1154.75	\$1175.10	\$1302.57	\$1351.84	\$1571.44	\$1625.01				
					2,3	QBSF-2936-CNN	■ ■ ■ ■	1181.53	1201.88	1329.35	1378.62	1598.22	1651.79		
					7,8,9	QBSF-2936-CNN	■ ■ ■ ■	1186.89	1207.24	1334.71	1383.98	1603.58	1657.15		
					K	QBSF-2936-CNN	■ K ■ ■	N/A	N/A	1366.84	1416.11	1635.71	1689.28		
Q	QBSF-2936-CNN	■ Q ■ ■	N/A	N/A	1398.98	1448.25	1667.85	1721.42							
12" Open/ Lateral File	29"(737mm)	23 7/8"(606mm)	24"(610mm)	1, J	QBSF-2924-DNN	■ ■ ■ ■	\$1258.67	\$1274.74	\$1387.21	\$1430.06	\$1617.52	\$1660.37			
						2,3	QBSF-2924-DNN	■ ■ ■ ■	1285.45	1301.52	1413.99	1456.84	1644.30	1687.15	
						7,8,9	QBSF-2924-DNN	■ ■ ■ ■	1290.81	1306.88	1419.35	1462.20	1649.66	1692.51	
						K	QBSF-2924-DNN	■ K ■ ■	N/A	N/A	1451.48	1494.33	1681.79	1724.64	
Q	QBSF-2924-DNN	■ Q ■ ■	N/A	N/A	1483.62	1526.47	1713.93	1756.78							
	29 7/8"(759mm)	30"(762mm)	1, J	QBSF-2930-DNN	■ ■ ■ ■	\$1335.80	\$1354.01	\$1473.98	\$1520.04	\$1723.57	\$1771.78				
					2,3	QBSF-2930-DNN	■ ■ ■ ■	1362.58	1380.79	1500.76	1546.82	1750.35	1798.56		
					7,8,9	QBSF-2930-DNN	■ ■ ■ ■	1367.94	1386.15	1506.12	1552.18	1755.71	1803.92		
					K	QBSF-2930-DNN	■ K ■ ■	N/A	N/A	1538.25	1584.31	1787.84	1836.05		
Q	QBSF-2930-DNN	■ Q ■ ■	N/A	N/A	1570.39	1616.45	1819.98	1868.19							
	35 7/8"(911mm)	36"(914mm)	1, J	QBSF-2936-DNN	■ ■ ■ ■	\$1412.93	\$1433.28	\$1560.75	\$1610.02	\$1829.62	\$1883.19				
					2,3	QBSF-2936-DNN	■ ■ ■ ■	1439.71	1460.06	1587.53	1636.80	1856.40	1909.97		
					7,8,9	QBSF-2936-DNN	■ ■ ■ ■	1445.07	1465.42	1592.89	1642.16	1861.76	1915.33		
					K	QBSF-2936-DNN	■ K ■ ■	N/A	N/A	1625.02	1674.29	1893.89	1947.46		
Q	QBSF-2936-DNN	■ Q ■ ■	N/A	N/A	1657.16	1706.43	1926.03	1979.60							
6" Open/Box Drawer/Lateral File	29"(737mm)	23 7/8"(606mm)	24"(610mm)	1, J	QBSF-2924-FNN	■ ■ ■ ■	\$1306.87	\$1322.94	\$1435.41	\$1478.26	\$1665.72	\$1708.57			
						2,3	QBSF-2924-FNN	■ ■ ■ ■	1360.43	1376.50	1488.97	1531.82	1719.28	1762.13	
						7,8,9	QBSF-2924-FNN	■ ■ ■ ■	1371.15	1387.22	1499.69	1542.54	1730.00	1772.85	
						K	QBSF-2924-FNN	■ K ■ ■	N/A	N/A	1563.95	1606.80	1794.26	1837.11	
Q	QBSF-2924-FNN	■ Q ■ ■	N/A	N/A	1628.23	1671.08	1858.54	1901.39							
	29 7/8"(759mm)	30"(762mm)	1, J	QBSF-2930-FNN	■ ■ ■ ■	\$1387.21	\$1405.42	\$1525.39	\$1571.45	\$1774.98	\$1823.19				
					2,3	QBSF-2930-FNN	■ ■ ■ ■	1440.77	1458.98	1578.95	1625.01	1828.54	1876.75		
					7,8,9	QBSF-2930-FNN	■ ■ ■ ■	1451.49	1469.70	1589.67	1635.73	1839.26	1887.47		
					K	QBSF-2930-FNN	■ K ■ ■	N/A	N/A	1653.93	1699.99	1903.52	1951.73		
Q	QBSF-2930-FNN	■ Q ■ ■	N/A	N/A	1718.21	1764.27	1967.80	2016.01							
	35 7/8"(911mm)	36"(914mm)	1, J	QBSF-2936-FNN	■ ■ ■ ■	\$1467.55	\$1487.90	\$1615.37	\$1664.64	\$1884.24	\$1937.81				
					2,3	QBSF-2936-FNN	■ ■ ■ ■	1521.11	1541.46	1668.93	1718.20	1937.80	1991.37		
					7,8,9	QBSF-2936-FNN	■ ■ ■ ■	1531.83	1552.18	1679.65	1728.92	1948.52	2002.09		
					K	QBSF-2936-FNN	■ K ■ ■	N/A	N/A	1743.91	1793.18	2012.78	2066.35		
Q	QBSF-2936-FNN	■ Q ■ ■	N/A	N/A	1808.19	1857.46	2077.06	2130.63							

*Finished Height includes worksurface top, spacer, base unit and legs

Base Unit — Open Storage with a Drawer — Single

Description	Finished Height*	Actual Width	Nominal Width	Pull	Number	Case Laminate B				Laminate Door		Wood Door			
						Steel Door Trim A	Trim B	A	B	Group A	Group B				
Single 1.5H															
Box Drawer/ 12" Open	23"(584mm)	23 7/8"(606mm)	24"(610mm)	1, J	QBSF-2324-CNN	■	■	■	■	\$ 952.30	\$ 964.08	\$1070.13	\$1112.98	\$1279.02	\$1321.87
				2,3	QBSF-2324-CNN	■	■	■	■	979.08	990.86	1096.91	1139.76	1305.80	1348.65
				7,8,9	QBSF-2324-CNN	■	■	■	■	984.44	996.22	1102.27	1145.12	1311.16	1354.01
				K	QBSF-2324-CNN	■	■	■	■	N/A	N/A	1134.40	1177.25	1343.29	1386.14
	Q	QBSF-2324-CNN	■	■	■	■	N/A	N/A	1166.54	1209.39	1375.43	1418.28			
	29 7/8"(759mm)	30"(762mm)	1, J	QBSF-2330-CNN	■	■	■	■	\$1004.79	\$1018.71	\$1132.26	\$1178.32	\$1360.43	\$1408.64	
			2,3	QBSF-2330-CNN	■	■	■	■	1031.57	1045.49	1159.04	1205.10	1387.21	1435.42	
			7,8,9	QBSF-2330-CNN	■	■	■	■	1036.93	1050.85	1164.40	1210.46	1392.57	1440.78	
			K	QBSF-2330-CNN	■	■	■	■	N/A	N/A	1196.53	1242.59	1424.70	1472.91	
	Q	QBSF-2330-CNN	■	■	■	■	N/A	N/A	1228.67	1274.73	1456.84	1505.05			
	35 7/8"(911mm)	36"(914mm)	1, J	QBSF-2336-CNN	■	■	■	■	\$1057.28	\$1073.34	\$1194.39	\$1243.66	\$1441.84	\$1495.41	
			2,3	QBSF-2336-CNN	■	■	■	■	1084.06	1100.12	1221.17	1270.44	1468.62	1522.19	
			7,8,9	QBSF-2336-CNN	■	■	■	■	1089.42	1105.48	1226.53	1275.80	1473.98	1527.55	
			K	QBSF-2336-CNN	■	■	■	■	N/A	N/A	1258.66	1307.93	1506.11	1559.68	
	Q	QBSF-2336-CNN	■	■	■	■	N/A	N/A	1290.80	1340.07	1538.25	1591.82			
	6" Open/ Lateral File	23"(584mm)	23 7/8"(606mm)	24"(610mm)	1, J	QBSF-2324-DNN	■	■	■	■	\$1247.95	\$1259.73	\$1365.78	\$1408.63	\$1574.67
2,3					QBSF-2324-DNN	■	■	■	■	1274.73	1286.51	1392.56	1435.41	1601.45	1644.30
7,8,9					QBSF-2324-DNN	■	■	■	■	1280.09	1291.87	1397.92	1440.77	1606.81	1649.66
K					QBSF-2324-DNN	■	■	■	■	N/A	N/A	1430.05	1472.90	1638.94	1681.79
Q		QBSF-2324-DNN	■	■	■	■	N/A	N/A	1462.19	1505.04	1671.08	1713.93			
29 7/8"(759mm)		30"(762mm)	1, J	QBSF-2330-DNN	■	■	■	■	\$1325.07	\$1338.99	\$1452.54	\$1498.60	\$1680.71	\$1728.92	
			2,3	QBSF-2330-DNN	■	■	■	■	1351.85	1365.77	1479.32	1525.38	1707.49	1755.70	
			7,8,9	QBSF-2330-DNN	■	■	■	■	1357.21	1371.13	1484.68	1530.74	1712.85	1761.06	
			K	QBSF-2330-DNN	■	■	■	■	N/A	N/A	1516.81	1562.87	1744.98	1793.19	
Q		QBSF-2330-DNN	■	■	■	■	N/A	N/A	1548.95	1595.01	1777.12	1825.33			
35 7/8"(911mm)		36"(914mm)	1, J	QBSF-2336-DNN	■	■	■	■	\$1402.19	\$1418.25	\$1539.30	\$1588.57	\$1786.75	\$1840.32	
			2,3	QBSF-2336-DNN	■	■	■	■	1428.97	1445.03	1566.08	1615.35	1813.53	1867.10	
			7,8,9	QBSF-2336-DNN	■	■	■	■	1434.33	1450.39	1571.44	1620.71	1818.89	1872.46	
			K	QBSF-2336-DNN	■	■	■	■	N/A	N/A	1603.57	1652.84	1851.02	1904.59	
Q		QBSF-2336-DNN	■	■	■	■	N/A	N/A	1635.71	1684.98	1883.16	1936.73			

*Finished Height includes worksurface top, spacer, base unit and legs

Base Unit — Open Storage with a Drawer — Single

Description	Finished Height*	Actual Width	Nominal Width	Pull	Number	Case Laminate B				Wood Door							
						Steel Door Trim A	Steel Door Trim B	Laminate Door A	Laminate Door B	Group A	Group B						
Single 2H																	
Box Drawer/ 18" Open	29"(737mm)	23 7/8"(606mm)	24"(610mm)	1, J	QBSF-2924-CNN	■ ■ ■ ■	\$1093.70	\$1109.77	\$1222.24	\$1265.09	\$1452.55	\$1495.40					
					2,3	QBSF-2924-CNN	■ ■ ■ ■	1120.48	1136.55	1249.02	1291.87	1479.33	1522.18				
					7,8,9	QBSF-2924-CNN	■ ■ ■ ■	1125.84	1141.91	1254.38	1297.23	1484.69	1527.54				
					K	QBSF-2924-CNN	■ K ■ ■	N/A	N/A	1286.51	1329.36	1516.82	1559.67				
					Q	QBSF-2924-CNN	■ Q ■ ■	N/A	N/A	1318.65	1361.50	1548.96	1591.81				
					29 7/8"(759mm)	30"(762mm)	1, J	QBSF-2930-CNN	■ ■ ■ ■	1153.68	1171.89	1291.86	1337.92	1541.45	1589.66		
					2,3	QBSF-2930-CNN	■ ■ ■ ■	1180.46	1198.67	1318.64	1364.70	1568.23	1616.44				
					7,8,9	QBSF-2930-CNN	■ ■ ■ ■	1185.82	1204.03	1324.00	1370.06	1573.59	1621.80				
					K	QBSF-2930-CNN	■ K ■ ■	N/A	N/A	1356.13	1402.19	1605.72	1653.93				
					Q	QBSF-2930-CNN	■ Q ■ ■	N/A	N/A	1388.27	1434.33	1637.86	1686.07				
					35 7/8"(911mm)	36"(914mm)	1, J	QBSF-2936-CNN	■ ■ ■ ■	1213.66	1234.01	1361.48	1410.75	1630.35	1683.92		
					2,3	QBSF-2936-CNN	■ ■ ■ ■	1240.44	1260.79	1388.26	1437.53	1657.13	1710.70				
					7,8,9	QBSF-2936-CNN	■ ■ ■ ■	1245.80	1266.15	1393.62	1442.89	1662.49	1716.06				
					K	QBSF-2936-CNN	■ K ■ ■	N/A	N/A	1425.75	1475.02	1694.62	1748.19				
					Q	QBSF-2936-CNN	■ Q ■ ■	N/A	N/A	1457.89	1507.16	1726.76	1780.33				
					12" Open/ Lateral File	29"(737mm)	23 7/8"(606mm)	24"(610mm)	1, J	QBSF-2924-DNN	■ ■ ■ ■	\$1313.30	\$1329.37	\$1441.84	\$1484.69	\$1672.15	\$1715.00
					2,3	QBSF-2924-DNN	■ ■ ■ ■	1340.08	1356.15	1468.62	1511.47	1698.93	1741.78				
					7,8,9	QBSF-2924-DNN	■ ■ ■ ■	1345.44	1361.51	1473.98	1516.83	1704.29	1747.14				
					K	QBSF-2924-DNN	■ K ■ ■	N/A	N/A	1506.11	1548.96	1736.42	1779.27				
					Q	QBSF-2924-DNN	■ Q ■ ■	N/A	N/A	1538.25	1581.10	1768.56	1811.41				
					29 7/8"(759mm)	30"(762mm)	1, J	QBSF-2930-DNN	■ ■ ■ ■	1392.57	1410.78	1530.75	1576.81	1780.34	1828.55		
					2,3	QBSF-2930-DNN	■ ■ ■ ■	1419.35	1437.56	1557.53	1603.59	1807.12	1855.33				
					7,8,9	QBSF-2930-DNN	■ ■ ■ ■	1424.71	1442.92	1562.89	1608.95	1812.48	1860.69				
					K	QBSF-2930-DNN	■ K ■ ■	N/A	N/A	1595.02	1641.08	1844.61	1892.82				
					Q	QBSF-2930-DNN	■ Q ■ ■	N/A	N/A	1627.16	1673.22	1876.75	1924.96				
					35 7/8"(911mm)	36"(914mm)	1, J	QBSF-2936-DNN	■ ■ ■ ■	1471.84	1492.19	1619.66	1668.93	1888.53	1942.10		
					2,3	QBSF-2936-DNN	■ ■ ■ ■	1498.62	1518.97	1646.44	1695.71	1915.31	1968.88				
					7,8,9	QBSF-2936-DNN	■ ■ ■ ■	1503.98	1524.33	1651.80	1701.07	1920.67	1974.24				
					K	QBSF-2936-DNN	■ K ■ ■	N/A	N/A	1683.93	1733.20	1952.80	2006.37				
					Q	QBSF-2936-DNN	■ Q ■ ■	N/A	N/A	1716.07	1765.34	1984.94	2038.51				
					6" Open/Box Drawer/Lateral File	29"(737mm)	23 7/8"(606mm)	24"(610mm)	1, J	QBSF-2924-FNN	■ ■ ■ ■	\$1361.50	\$1377.57	\$1490.04	\$1532.89	\$1720.35	\$1763.20
										2,3	QBSF-2924-FNN	■ ■ ■ ■	1415.06	1431.13	1543.60	1586.45	1773.91
7,8,9	QBSF-2924-FNN	■ ■ ■ ■	1425.78	1441.85						1554.32	1597.17	1784.63	1827.48				
K	QBSF-2924-FNN	■ K ■ ■	N/A	N/A						1618.58	1661.43	1848.89	1891.74				
Q	QBSF-2924-FNN	■ Q ■ ■	N/A	N/A						1682.86	1725.71	1913.17	1956.02				
					29 7/8"(759mm)	30"(762mm)	1, J	QBSF-2930-FNN	■ ■ ■ ■	1443.98	1462.19	1582.16	1628.22	1831.75	1879.96		
					2,3	QBSF-2930-FNN	■ ■ ■ ■	1497.54	1515.75	1635.72	1681.78	1885.31	1933.52				
					7,8,9	QBSF-2930-FNN	■ ■ ■ ■	1508.26	1526.47	1646.44	1692.50	1896.03	1944.24				
					K	QBSF-2930-FNN	■ K ■ ■	N/A	N/A	1710.70	1756.76	1960.29	2008.50				
					Q	QBSF-2930-FNN	■ Q ■ ■	N/A	N/A	1774.98	1821.04	2024.57	2072.78				
					35 7/8"(911mm)	36"(914mm)	1, J	QBSF-2936-FNN	■ ■ ■ ■	1526.46	1546.81	1674.28	1723.55	1943.15	1996.72		
					2,3	QBSF-2936-FNN	■ ■ ■ ■	1580.02	1600.37	1727.84	1777.11	1996.71	2050.28				
					7,8,9	QBSF-2936-FNN	■ ■ ■ ■	1590.74	1611.09	1738.56	1787.83	2007.43	2061.00				
					K	QBSF-2936-FNN	■ K ■ ■	N/A	N/A	1802.82	1852.09	2071.69	2125.26				
					Q	QBSF-2936-FNN	■ Q ■ ■	N/A	N/A	1867.10	1916.37	2135.97	2189.54				

*Finished Height includes worksurface top, spacer, base unit and legs

This page intentionally blank

Base Unit — Open Storage with a Drawer — Double

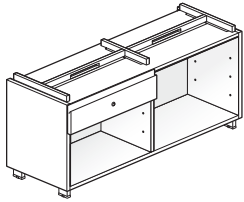

QBDF-XXXX-CZN

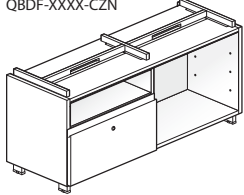

QBDF-XXXX-DZN

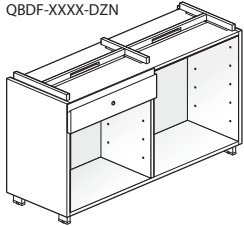

QBDF-XXXX-CZN

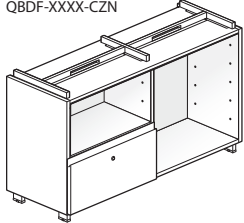

QBDF-XXXX-DZN

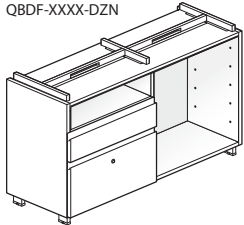

QBDF-XXXX-FZN

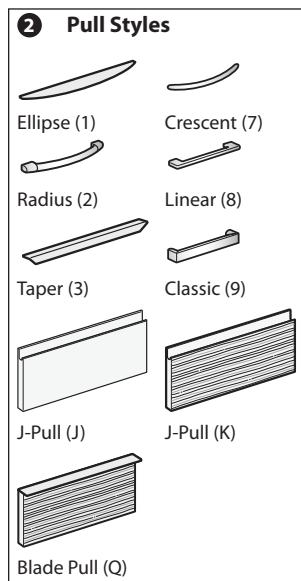

Features

- Open Storage with a drawer include:
 - Laminate end panel and inner top.
 - Painted Steel inner back and bottom.
 - Painted Steel spacer.
- Leg Options:
 - Straight Leg (F)
 - Chamfer Leg (P)
- Glide adjustment range:
 - Straight Leg: 1.5”(38mm)
 - Chamfer Leg: 1.25”(32mm)
- Spacer:
 - 1.18”(30mm) high
 - End pieces come in specified color; center spacer section black only.
- Drawer interior is black.
- Optional drawer front options include painted steel, laminate or wood.
- Lateral file includes side-to-side filing bar.
- Full extension drawers.
- Ellipse pull available in non-metallic color only. (see finish page for pull color)
- Radius pull available in metallic colors only. (see finish page for pull color)
- J-Pull (J) matches painted steel front.
- J-Pull (K) or Blade Pull (Q) available on laminate or wood fronts only. Must specify color.
- Lock Options:
 - Locking (chrome only) and non-locking available.
 - One lock accommodates all drawers.
- Shelves are separately specified; not included with unit.
- Case ships assembled. Legs require field installation.

Specification Tips

- Designed to be used with Haworth's Integrated Palette, UniGroup Too, PREMISE, Reside Desking and/or Belong Work Tools.
- All base units with drawers must be attached. Refer to Specification Guide for planning information.
- Separately specified storage tops are required and can match the width of a single base unit or span two or more adjacent base units side by side.
- To route and access power in storage, order separately specified Belong power components.
- 1.5H and 2H storage can be used to support Reside desking or Adaptable worksurfaces in a perpendicular configuration with separately specified brackets. Refer to Specification Guide for planning information.
- Beside base storage unit with top, spacer, base unit and legs finished heights:
 - 1H = 17”(432mm)
 - 1.5H = 23”(584mm)
 - 2H = 29”(737mm)
- Separately specified if applicable:
 - Belong Power and communication cabling, tools, screens and tool rails.
 - Storage-to-Panel Bracket
 - Storage Attachment Bracket
 - Ganging Bracket
 - Storage Top (required)
 - Filler Panel
 - Top Filler Track
 - Finished Back (recommended when back is exposed)
 - Adjustable Shelf (not included with unit)
 - Stack-On Hutch
 - Front-to-Back Filing Bars
- Refer to Specification Guide for planning information and actual dimensions.

Notes: 2H storage base units are not designed to fit under Reside benching or return worksurfaces. Reside Desking or Adaptable worksurfaces can be attached to the front or back of a 2H Beside storage unit with separately specified flush mount plates.

Separately specified Belong base unit power components available for 30”-72”(372mm-1829mm) widths only.

Storage shelves are unique to the specific base unit configuration. Refer to shelf price list pages for appropriate shelf.

To Order, Specify:

Steel Drawer Front

1) Product number, including:

1 Steel Drawer Front Option:

S Steel

2 Pull Option: (see side bar)

3 Leg Option:

F Straight Leg

P Chamfer Leg, add **\$85.70** list

4 Lock Option:

L Locking, add **\$42.85** list

N Non-Locking

2) Case laminate color.

3) Case laminate edgeband color.

4) Bottom, inset back and fixed shelf trim color.

5) Pull, leg and spacer trim color.

6) Drawer front steel color.

Laminate or Wood Drawer Front

1) Product number, including:

1 Laminate or Wood Drawer Front Option:

L Laminate

W Wood

2 Pull Option: (see side bar)

3 Leg Option:

F Straight Leg

P Chamfer Leg, add **\$85.70** list

4 Lock Option:

L Locking, add **\$42.85** list

N Non-Locking

2) Case laminate color.

3) Case laminate edgeband color.

4) Bottom, inset back and fixed shelf trim color.

5) Pull, leg and spacer trim color.

6) Drawer front laminate or wood color.

7) Laminate drawer front edgeband color.

Note: Upcharge for mixed grade fabric or trim surfaces, refer to the electronic design and specification tools for pricing.

Base Unit — Open Storage with a Drawer — Double

Description	Finished Height*	Actual Width	Nominal Width	Pull	Number	Case Laminate A				Wood Door Group A	Wood Door Group B				
						Steel Door Trim A	Steel Door Trim B	Laminate Door A	Laminate Door B						
Double 1.5H															
Open — Left Box Drawer/ 12" Open	23"(584mm)	47 7/8"(1216mm)	48"(1219mm)	1,J	QBDF-2348-ZCN	■ ■ ■ ■	■ ■ ■ ■	■ ■ ■ ■	■ ■ ■ ■	\$1153.68	\$1174.02	\$1310.07	\$1365.76	\$1596.08	\$1660.37
				2,3	QBDF-2348-ZCN	■ ■ ■ ■	■ ■ ■ ■	■ ■ ■ ■	■ ■ ■ ■	1180.46	1200.80	1336.85	1392.54	1622.86	1687.15
				7,8,9	QBDF-2348-ZCN	■ ■ ■ ■	■ ■ ■ ■	■ ■ ■ ■	■ ■ ■ ■	1185.82	1206.16	1342.21	1397.90	1628.22	1692.51
				K	QBDF-2348-ZCN	■ ■ ■ ■	■ ■ ■ ■	■ ■ ■ ■	■ ■ ■ ■	N/A	N/A	1374.34	1430.03	1660.35	1724.64
				Q	QBDF-2348-ZCN	■ ■ ■ ■	■ ■ ■ ■	■ ■ ■ ■	■ ■ ■ ■	N/A	N/A	1406.48	1462.17	1720.34	1784.63
	59 7/8"(1521mm)	60"(1524mm)		1,J	QBDF-2360-ZCN	■ ■ ■ ■	■ ■ ■ ■	■ ■ ■ ■	■ ■ ■ ■	\$1243.66	\$1268.28	\$1419.33	\$1481.44	\$1743.90	\$1818.91
				2,3	QBDF-2360-ZCN	■ ■ ■ ■	■ ■ ■ ■	■ ■ ■ ■	■ ■ ■ ■	1270.44	1295.06	1446.11	1508.22	1770.68	1845.69
				7,8,9	QBDF-2360-ZCN	■ ■ ■ ■	■ ■ ■ ■	■ ■ ■ ■	■ ■ ■ ■	1275.80	1300.42	1451.47	1513.58	1776.04	1851.05
				K	QBDF-2360-ZCN	■ ■ ■ ■	■ ■ ■ ■	■ ■ ■ ■	■ ■ ■ ■	N/A	N/A	1483.60	1545.71	1808.17	1883.18
				Q	QBDF-2360-ZCN	■ ■ ■ ■	■ ■ ■ ■	■ ■ ■ ■	■ ■ ■ ■	N/A	N/A	1515.74	1577.85	1868.16	1943.17
	71 7/8"(1826mm)	72"(1829mm)		1,J	QBDF-2372-ZCN	■ ■ ■ ■	■ ■ ■ ■	■ ■ ■ ■	■ ■ ■ ■	\$1333.64	\$1362.54	\$1528.59	\$1597.12	\$1891.72	\$1977.45
				2,3	QBDF-2372-ZCN	■ ■ ■ ■	■ ■ ■ ■	■ ■ ■ ■	■ ■ ■ ■	1360.42	1389.32	1555.37	1623.90	1918.50	2004.23
				7,8,9	QBDF-2372-ZCN	■ ■ ■ ■	■ ■ ■ ■	■ ■ ■ ■	■ ■ ■ ■	1365.78	1394.68	1560.73	1629.26	1923.86	2009.59
				K	QBDF-2372-ZCN	■ ■ ■ ■	■ ■ ■ ■	■ ■ ■ ■	■ ■ ■ ■	N/A	N/A	1592.86	1661.39	1955.99	2041.72
				Q	QBDF-2372-ZCN	■ ■ ■ ■	■ ■ ■ ■	■ ■ ■ ■	■ ■ ■ ■	N/A	N/A	1652.85	1721.38	2015.98	2101.71
Box Drawer/ 12" Open	23"(584mm)	47 7/8"(1216mm)	48"(1219mm)	1,J	QBDF-2348-CZN	■ ■ ■ ■	■ ■ ■ ■	■ ■ ■ ■	■ ■ ■ ■	\$1153.68	\$1174.02	\$1310.07	\$1365.76	\$1596.08	\$1660.37
Open — Right				2,3	QBDF-2348-CZN	■ ■ ■ ■	■ ■ ■ ■	■ ■ ■ ■	■ ■ ■ ■	1180.46	1200.80	1336.85	1392.54	1622.86	1687.15
				7,8,9	QBDF-2348-CZN	■ ■ ■ ■	■ ■ ■ ■	■ ■ ■ ■	■ ■ ■ ■	1185.82	1206.16	1342.21	1397.90	1628.22	1692.51
				K	QBDF-2348-CZN	■ ■ ■ ■	■ ■ ■ ■	■ ■ ■ ■	■ ■ ■ ■	N/A	N/A	1374.34	1430.03	1660.35	1724.64
				Q	QBDF-2348-CZN	■ ■ ■ ■	■ ■ ■ ■	■ ■ ■ ■	■ ■ ■ ■	N/A	N/A	1406.48	1462.17	1720.34	1784.63
	59 7/8"(1521mm)	60"(1524mm)		1,J	QBDF-2360-CZN	■ ■ ■ ■	■ ■ ■ ■	■ ■ ■ ■	■ ■ ■ ■	\$1243.66	\$1268.28	\$1419.33	\$1481.44	\$1743.90	\$1818.91
				2,3	QBDF-2360-CZN	■ ■ ■ ■	■ ■ ■ ■	■ ■ ■ ■	■ ■ ■ ■	1270.44	1295.06	1446.11	1508.22	1770.68	1845.69
				7,8,9	QBDF-2360-CZN	■ ■ ■ ■	■ ■ ■ ■	■ ■ ■ ■	■ ■ ■ ■	1275.80	1300.42	1451.47	1513.58	1776.04	1851.05
				K	QBDF-2360-CZN	■ ■ ■ ■	■ ■ ■ ■	■ ■ ■ ■	■ ■ ■ ■	N/A	N/A	1483.60	1545.71	1808.17	1883.18
				Q	QBDF-2360-CZN	■ ■ ■ ■	■ ■ ■ ■	■ ■ ■ ■	■ ■ ■ ■	N/A	N/A	1515.74	1577.85	1868.16	1943.17
	71 7/8"(1826mm)	72"(1829mm)		1,J	QBDF-2372-CZN	■ ■ ■ ■	■ ■ ■ ■	■ ■ ■ ■	■ ■ ■ ■	\$1333.64	\$1362.54	\$1528.59	\$1597.12	\$1891.72	\$1977.45
				2,3	QBDF-2372-CZN	■ ■ ■ ■	■ ■ ■ ■	■ ■ ■ ■	■ ■ ■ ■	1360.42	1389.32	1555.37	1623.90	1918.50	2004.23
				7,8,9	QBDF-2372-CZN	■ ■ ■ ■	■ ■ ■ ■	■ ■ ■ ■	■ ■ ■ ■	1365.78	1394.68	1560.73	1629.26	1923.86	2009.59
				K	QBDF-2372-CZN	■ ■ ■ ■	■ ■ ■ ■	■ ■ ■ ■	■ ■ ■ ■	N/A	N/A	1592.86	1661.39	1955.99	2041.72
				Q	QBDF-2372-CZN	■ ■ ■ ■	■ ■ ■ ■	■ ■ ■ ■	■ ■ ■ ■	N/A	N/A	1625.00	1693.53	2015.98	2101.71
Open — Left 6" Open/ Lateral File	23"(584mm)	47 7/8"(1216mm)	48"(1219mm)	1,J	QBDF-2348-ZDN	■ ■ ■ ■	■ ■ ■ ■	■ ■ ■ ■	■ ■ ■ ■	\$1576.81	\$1597.15	\$1733.20	\$1788.89	\$2019.21	\$2083.50
				2,3	QBDF-2348-ZDN	■ ■ ■ ■	■ ■ ■ ■	■ ■ ■ ■	■ ■ ■ ■	1603.59	1623.93	1759.98	1815.67	2045.99	2110.28
				7,8,9	QBDF-2348-ZDN	■ ■ ■ ■	■ ■ ■ ■	■ ■ ■ ■	■ ■ ■ ■	1608.95	1629.29	1765.34	1821.03	2051.35	2115.64
				K	QBDF-2348-ZDN	■ ■ ■ ■	■ ■ ■ ■	■ ■ ■ ■	■ ■ ■ ■	N/A	N/A	1797.47	1853.16	2083.48	2147.77
				Q	QBDF-2348-ZDN	■ ■ ■ ■	■ ■ ■ ■	■ ■ ■ ■	■ ■ ■ ■	N/A	N/A	1829.61	1885.30	2143.47	2207.76
	59 7/8"(1521mm)	60"(1524mm)		1,J	QBDF-2360-ZDN	■ ■ ■ ■	■ ■ ■ ■	■ ■ ■ ■	■ ■ ■ ■	\$1703.21	\$1727.83	\$1878.88	\$1940.99	\$2203.45	\$2278.46
				2,3	QBDF-2360-ZDN	■ ■ ■ ■	■ ■ ■ ■	■ ■ ■ ■	■ ■ ■ ■	1729.99	1754.61	1905.66	1967.77	2230.23	2305.24
				7,8,9	QBDF-2360-ZDN	■ ■ ■ ■	■ ■ ■ ■	■ ■ ■ ■	■ ■ ■ ■	1735.35	1759.97	1911.02	1973.13	2235.59	2310.60
				K	QBDF-2360-ZDN	■ ■ ■ ■	■ ■ ■ ■	■ ■ ■ ■	■ ■ ■ ■	N/A	N/A	1943.15	2005.26	2267.72	2342.73
				Q	QBDF-2360-ZDN	■ ■ ■ ■	■ ■ ■ ■	■ ■ ■ ■	■ ■ ■ ■	N/A	N/A	1975.29	2037.40	2327.71	2402.72
	71 7/8"(1826mm)	72"(1829mm)		1,J	QBDF-2372-ZDN	■ ■ ■ ■	■ ■ ■ ■	■ ■ ■ ■	■ ■ ■ ■	\$1829.61	\$1858.51	\$2024.56	\$2093.09	\$2387.69	\$2473.42
				2,3	QBDF-2372-ZDN	■ ■ ■ ■	■ ■ ■ ■	■ ■ ■ ■	■ ■ ■ ■	1856.39	1885.29	2051.34	2119.87	2414.47	2500.20
				7,8,9	QBDF-2372-ZDN	■ ■ ■ ■	■ ■ ■ ■	■ ■ ■ ■	■ ■ ■ ■	1861.75	1890.65	2056.70	2125.23	2419.83	2505.56
				K	QBDF-2372-ZDN	■ ■ ■ ■	■ ■ ■ ■	■ ■ ■ ■	■ ■ ■ ■	N/A	N/A	2088.83	2157.36	2451.96	2537.69
				Q	QBDF-2372-ZDN	■ ■ ■ ■	■ ■ ■ ■	■ ■ ■ ■	■ ■ ■ ■	N/A	N/A	2120.97	2189.50	2511.95	2597.68
6" Open/ Lateral File	23"(584mm)	47 7/8"(1216mm)	48"(1219mm)	1,J	QBDF-2348-DZN	■ ■ ■ ■	■ ■ ■ ■	■ ■ ■ ■	■ ■ ■ ■	\$1576.81	\$1597.15	\$1733.20	\$1788.89	\$2019.21	\$2083.50
Open — Right				2,3	QBDF-2348-DZN	■ ■ ■ ■	■ ■ ■ ■	■ ■ ■ ■	■ ■ ■ ■	1603.59	1623.93	1759.98	1815.67	2045.99	2110.28
				7,8,9	QBDF-2348-DZN	■ ■ ■ ■	■ ■ ■ ■	■ ■ ■ ■	■ ■ ■ ■	1608.95	1629.29	1765.34	1821.03	2051.35	2115.64
				K	QBDF-2348-DZN	■ ■ ■ ■	■ ■ ■ ■	■ ■ ■ ■	■ ■ ■ ■	N/A	N/A	1797.47	1853.16	2083.48	2147.77
				Q	QBDF-2348-DZN	■ ■ ■ ■	■ ■ ■ ■	■ ■ ■ ■	■ ■ ■ ■	N/A	N/A	1829.61	1885.30	2143.47	2207.76
	59 7/8"(1521mm)	60"(1524mm)		1,J	QBDF-2360-DZN	■ ■ ■ ■	■ ■ ■ ■	■ ■ ■ ■	■ ■ ■ ■	\$1703.21	\$1727.83	\$1878.88	\$1940.99	\$2203.45	\$2278.46
				2,3	QBDF-2360-DZN	■ ■ ■ ■	■ ■ ■ ■	■ ■ ■ ■	■ ■ ■ ■	1729.99	1754.61	1905.66	1967.77	2230.23	2305.24
				7,8,9	QBDF-2360-DZN	■ ■ ■ ■	■ ■ ■ ■	■ ■ ■ ■	■ ■ ■ ■	1735.35	1759.97	1911.02	1973.13	2235.59	2310.60
				K	QBDF-2360-DZN	■ ■ ■ ■	■ ■ ■ ■	■ ■ ■ ■	■ ■ ■ ■	N/A	N/A	1943.15	2005.26	2267.72	2342.73
				Q	QBDF-2360-DZN	■ ■ ■ ■	■ ■ ■ ■	■ ■ ■ ■	■ ■ ■ ■	N/A	N/A	1975.29	2037.40	2327.71	2402.72
	71 7/8"(1826mm)	72"(1829mm)		1,J	QBDF-2372-DZN	■ ■ ■ ■	■ ■ ■ ■	■ ■ ■ ■	■ ■ ■ ■	\$1829.61	\$1858.51	\$2024.56	\$2093.09	\$2387.69	\$2473.42
				2,3	QBDF-2372-DZN	■ ■ ■ ■	■ ■ ■ ■	■ ■ ■ ■	■ ■ ■ ■	1856.39	1885.29	2051.34	2119.87	2414.47	2500.20
				7,8,9	QBDF-2372-DZN	■ ■ ■ ■	■ ■ ■ ■	■ ■ ■ ■	■ ■ ■ ■	1861.75	1890.65	2056.70	2125.23	2419.83	2505.56
				K	QBDF-2372-DZN	■ ■ ■ ■	■ ■ ■ ■	■ ■ ■ ■	■ ■ ■ ■	N/A	N/A	2088.83	2157.36	2451.96	2537.69
				Q	QBDF-2372-DZN	■ ■ ■ ■	■ ■ ■ ■	■ ■ ■ ■	■ ■ ■ ■	N/A	N/A	2120.97	2189.50	2511.95	2597.68

*Finished Height includes worksurface top, spacer, base unit and legs

Base Unit — Open Storage with a Drawer — Double

Description	Finished Height*	Actual Width	Nominal Width	Pull	Number	Case Laminate A				Wood Door Group A	Wood Door Group B	
						Steel Door Trim A	Steel Door Trim B	Laminate Door A	Laminate Door B			
Double 2H												
Open — Left Box Drawer/ 18" Open	29"(737mm)	47 7/8"(1216mm)	48"(1219mm)	1, J	QBDF-2948-ZCN	■ ■ ■ ■	\$1432.20	\$1456.83	\$1599.30	\$1654.99	\$1906.73	\$1971.02
				2,3	QBDF-2948-ZCN	■ ■ ■ ■	1458.98	1483.61	1626.08	1681.77	1933.51	1997.80
				7,8,9	QBDF-2948-ZCN	■ ■ ■ ■	1464.34	1488.97	1631.44	1687.13	1938.87	2003.16
				K	QBDF-2948-ZCN	K ■ ■ ■	N/A	N/A	1663.57	1719.26	1971.00	2035.29
				Q	QBDF-2948-ZCN	Q ■ ■ ■	N/A	N/A	1695.71	1751.40	2003.14	2067.43
	59 7/8"(1521mm)	60"(1524mm)		1, J	QBDF-2960-ZCN	■ ■ ■ ■	\$1522.18	\$1551.09	\$1708.56	\$1770.67	\$2054.55	\$2129.56
				2,3	QBDF-2960-ZCN	■ ■ ■ ■	1548.96	1577.87	1735.34	1797.45	2081.33	2156.34
				7,8,9	QBDF-2960-ZCN	■ ■ ■ ■	1554.32	1583.23	1740.70	1802.81	2086.69	2161.70
				K	QBDF-2960-ZCN	K ■ ■ ■	N/A	N/A	1772.83	1834.94	2118.82	2193.83
				Q	QBDF-2960-ZCN	Q ■ ■ ■	N/A	N/A	1804.97	1867.08	2150.96	2225.97
	71 7/8"(1826mm)	72"(1829mm)		1, J	QBDF-2972-ZCN	■ ■ ■ ■	\$1612.16	\$1645.35	\$1817.82	\$1886.35	\$2202.37	\$2288.10
				2,3	QBDF-2972-ZCN	■ ■ ■ ■	1638.94	1672.13	1844.60	1913.13	2229.15	2314.88
				7,8,9	QBDF-2972-ZCN	■ ■ ■ ■	1644.30	1677.49	1849.96	1918.49	2234.51	2320.24
				K	QBDF-2972-ZCN	K ■ ■ ■	N/A	N/A	1882.09	1950.62	2266.64	2352.37
				Q	QBDF-2972-ZCN	Q ■ ■ ■	N/A	N/A	1914.23	1982.76	2298.78	2384.51
Box Drawer/ 18" Open	29"(737mm)	47 7/8"(1216mm)	48"(1219mm)	1, J	QBDF-2948-CZN	■ ■ ■ ■	\$1432.20	\$1456.83	\$1599.30	\$1654.99	\$1906.73	\$1971.02
Open — Right				2,3	QBDF-2948-CZN	■ ■ ■ ■	1458.98	1483.61	1626.08	1681.77	1933.51	1997.80
				7,8,9	QBDF-2948-CZN	■ ■ ■ ■	1464.34	1488.97	1631.44	1687.13	1938.87	2003.16
				K	QBDF-2948-CZN	K ■ ■ ■	N/A	N/A	1663.57	1719.26	1971.00	2035.29
				Q	QBDF-2948-CZN	Q ■ ■ ■	N/A	N/A	1695.71	1751.40	2003.14	2067.43
	59 7/8"(1521mm)	60"(1524mm)		1, J	QBDF-2960-CZN	■ ■ ■ ■	\$1522.18	\$1551.09	\$1708.56	\$1770.67	\$2054.55	\$2129.56
				2,3	QBDF-2960-CZN	■ ■ ■ ■	1548.96	1577.87	1735.34	1797.45	2081.33	2156.34
				7,8,9	QBDF-2960-CZN	■ ■ ■ ■	1554.32	1583.23	1740.70	1802.81	2086.69	2161.70
				K	QBDF-2960-CZN	K ■ ■ ■	N/A	N/A	1772.83	1834.94	2118.82	2193.83
				Q	QBDF-2960-CZN	Q ■ ■ ■	N/A	N/A	1804.97	1867.08	2150.96	2225.97
	71 7/8"(1826mm)	72"(1829mm)		1, J	QBDF-2972-CZN	■ ■ ■ ■	\$1612.16	\$1645.35	\$1817.82	\$1886.35	\$2202.37	\$2288.10
				2,3	QBDF-2972-CZN	■ ■ ■ ■	1638.94	1672.13	1844.60	1913.13	2229.15	2314.88
				7,8,9	QBDF-2972-CZN	■ ■ ■ ■	1644.30	1677.49	1849.96	1918.49	2234.51	2320.24
				K	QBDF-2972-CZN	K ■ ■ ■	N/A	N/A	1882.09	1950.62	2266.64	2352.37
				Q	QBDF-2972-CZN	Q ■ ■ ■	N/A	N/A	1914.23	1982.76	2298.78	2384.51
Open — Left 12" Open/ Lateral File	29"(737mm)	47 7/8"(1216mm)	48"(1219mm)	1, J	QBDF-2948-ZDN	■ ■ ■ ■	\$1817.83	\$1842.46	\$1984.93	\$2040.62	\$2292.36	\$2356.65
				2,3	QBDF-2948-ZDN	■ ■ ■ ■	1844.61	1869.24	2011.71	2067.40	2319.14	2383.43
				7,8,9	QBDF-2948-ZDN	■ ■ ■ ■	1849.97	1874.60	2017.07	2072.76	2324.50	2388.79
				K	QBDF-2948-ZDN	K ■ ■ ■	N/A	N/A	2049.20	2104.89	2356.63	2420.92
				Q	QBDF-2948-ZDN	Q ■ ■ ■	N/A	N/A	2081.34	2137.03	2388.77	2453.06
	59 7/8"(1521mm)	60"(1524mm)		1, J	QBDF-2960-ZDN	■ ■ ■ ■	\$1959.23	\$1988.14	\$2145.61	\$2207.72	\$2491.60	\$2566.61
				2,3	QBDF-2960-ZDN	■ ■ ■ ■	1986.01	2014.92	2172.39	2234.50	2518.38	2593.39
				7,8,9	QBDF-2960-ZDN	■ ■ ■ ■	1991.37	2020.28	2177.75	2239.86	2523.74	2598.75
				K	QBDF-2960-ZDN	K ■ ■ ■	N/A	N/A	2209.88	2271.99	2555.87	2630.88
				Q	QBDF-2960-ZDN	Q ■ ■ ■	N/A	N/A	2242.02	2304.13	2588.01	2663.02
	71 7/8"(1826mm)	72"(1829mm)		1, J	QBDF-2972-ZDN	■ ■ ■ ■	\$2100.63	\$2133.82	\$2306.29	\$2374.82	\$2690.84	\$2776.57
				2,3	QBDF-2972-ZDN	■ ■ ■ ■	2127.41	2160.60	2333.07	2401.60	2717.62	2803.35
				7,8,9	QBDF-2972-ZDN	■ ■ ■ ■	2132.77	2165.96	2338.43	2406.96	2722.98	2808.71
				K	QBDF-2972-ZDN	K ■ ■ ■	N/A	N/A	2370.56	2439.09	2755.11	2840.84
				Q	QBDF-2972-ZDN	Q ■ ■ ■	N/A	N/A	2402.70	2471.23	2787.25	2872.98
12" Open/ Lateral File	29"(737mm)	47 7/8"(1216mm)	48"(1219mm)	1, J	QBDF-2948-DZN	■ ■ ■ ■	\$1817.83	\$1842.46	\$1984.93	\$2040.62	\$2292.36	\$2356.65
Open — Right				2,3	QBDF-2948-DZN	■ ■ ■ ■	1844.61	1869.24	2011.71	2067.40	2319.14	2383.43
				7,8,9	QBDF-2948-DZN	■ ■ ■ ■	1849.97	1874.60	2017.07	2072.76	2324.50	2388.79
				K	QBDF-2948-DZN	K ■ ■ ■	N/A	N/A	2049.20	2104.89	2356.63	2420.92
				Q	QBDF-2948-DZN	Q ■ ■ ■	N/A	N/A	2081.34	2137.03	2388.77	2453.06
	59 7/8"(1521mm)	60"(1524mm)		1, J	QBDF-2960-DZN	■ ■ ■ ■	\$1959.23	\$1988.14	\$2145.61	\$2207.72	\$2491.60	\$2566.61
				2,3	QBDF-2960-DZN	■ ■ ■ ■	1986.01	2014.92	2172.39	2234.50	2518.38	2593.39
				7,8,9	QBDF-2960-DZN	■ ■ ■ ■	1991.37	2020.28	2177.75	2239.86	2523.74	2598.75
				K	QBDF-2960-DZN	K ■ ■ ■	N/A	N/A	2209.88	2271.99	2555.87	2630.88
				Q	QBDF-2960-DZN	Q ■ ■ ■	N/A	N/A	2242.02	2304.13	2588.01	2663.02
	71 7/8"(1826mm)	72"(1829mm)		1, J	QBDF-2972-DZN	■ ■ ■ ■	\$2100.63	\$2133.82	\$2306.29	\$2374.82	\$2690.84	\$2776.57
				2,3	QBDF-2972-DZN	■ ■ ■ ■	2127.41	2160.60	2333.07	2401.60	2717.62	2803.35
				7,8,9	QBDF-2972-DZN	■ ■ ■ ■	2132.77	2165.96	2338.43	2406.96	2722.98	2808.71
				K	QBDF-2972-DZN	K ■ ■ ■	N/A	N/A	2370.56	2439.09	2755.11	2840.84
				Q	QBDF-2972-DZN	Q ■ ■ ■	N/A	N/A	2402.70	2471.23	2787.25	2872.98

*Finished Height includes worksurface top, spacer, base unit and legs

Base Unit — Open Storage with a Drawer — Double

Description	Finished Height*	Actual Width	Nominal Width	Pull	Number	Case Laminate A				Wood Door Group A	Wood Door Group B							
						Steel Door Trim A	Steel Door Trim B	Laminate Door A	Laminate Door B									
Open — Left 6" Open/ Box Drawer/ Lateral File	29"(737mm)	47 7/8"(1216mm)	48"(1219mm)	1, J	QBDF-2948-ZFN	1	2	3	4	\$1887.46	\$1912.09	\$2054.56	\$2110.25	\$2361.99	\$2426.28			
						2,3	QBDF-2948-ZFN					1941.02	1965.65	2108.12	2163.81	2415.55	2479.84	
						7,8,9	QBDF-2948-ZFN					1951.74	1976.37	2118.84	2174.53	2426.27	2490.56	
						K	QBDF-2948-ZFN	K				N/A	N/A	2183.10	2238.79	2490.53	2554.82	
	59 7/8"(1521mm)	60"(1524mm)	1, J	QBDF-2960-ZFN	1	2	3	4	\$2031.00	\$2059.91	\$2217.38	\$2279.49	\$2563.37	\$2638.38				
					2,3	QBDF-2960-ZFN					2084.56	2113.47	2270.94	2333.05	2616.93	2691.94		
					7,8,9	QBDF-2960-ZFN					2095.28	2124.19	2281.66	2343.77	2627.65	2702.66		
					K	QBDF-2960-ZFN	K				N/A	N/A	2345.92	2408.03	2691.91	2766.92		
	71 7/8"(1826mm)	72"(1829mm)	1, J	QBDF-2972-ZFN	1	2	3	4	\$2174.54	\$2207.73	\$2380.20	\$2448.73	\$2764.75	\$2850.48				
					2,3	QBDF-2972-ZFN					2228.10	2261.29	2433.76	2502.29	2818.31	2904.04		
					7,8,9	QBDF-2972-ZFN					2238.82	2272.01	2444.48	2513.01	2829.03	2914.76		
					K	QBDF-2972-ZFN	K				N/A	N/A	2508.74	2577.27	2893.29	2979.02		
	6" Open/ Box Drawer/ Lateral File Open — Right	29"(737mm)	47 7/8"(1216mm)	48"(1219mm)	1, J	QBDF-2948-FZN	1	2	3	4	\$1887.46	\$1912.09	\$2054.56	\$2110.25	\$2361.99	\$2426.28		
							2,3	QBDF-2948-FZN					1941.02	1965.65	2108.12	2163.81	2415.55	2479.84
							7,8,9	QBDF-2948-FZN					1951.74	1976.37	2118.84	2174.53	2426.27	2490.56
							K	QBDF-2948-FZN	K				N/A	N/A	2183.10	2238.79	2490.53	2554.82
59 7/8"(1521mm)		60"(1524mm)	1, J	QBDF-2960-FZN	1	2	3	4	\$2031.00	\$2059.91	\$2217.38	\$2279.49	\$2563.37	\$2638.38				
					2,3	QBDF-2960-FZN					2084.56	2113.47	2270.94	2333.05	2616.93	2691.94		
					7,8,9	QBDF-2960-FZN					2095.28	2124.19	2281.66	2343.77	2627.65	2702.66		
					K	QBDF-2960-FZN	K				N/A	N/A	2345.92	2408.03	2691.91	2766.92		
71 7/8"(1826mm)		72"(1829mm)	1, J	QBDF-2972-FZN	1	2	3	4	\$2174.54	\$2207.73	\$2380.20	\$2448.73	\$2764.75	\$2850.48				
					2,3	QBDF-2972-FZN					2228.10	2261.29	2433.76	2502.29	2818.31	2904.04		
					7,8,9	QBDF-2972-FZN					2238.82	2272.01	2444.48	2513.01	2829.03	2914.76		
					K	QBDF-2972-FZN	K				N/A	N/A	2508.74	2577.27	2893.29	2979.02		
						QBDF-2972-FZN	1	2	3	4	\$2174.54	\$2207.73	\$2380.20	\$2448.73	\$2764.75	\$2850.48		
							2,3	QBDF-2972-FZN					2228.10	2261.29	2433.76	2502.29	2818.31	2904.04
							7,8,9	QBDF-2972-FZN					2238.82	2272.01	2444.48	2513.01	2829.03	2914.76
							K	QBDF-2972-FZN	K				N/A	N/A	2508.74	2577.27	2893.29	2979.02
					QBDF-2972-FZN	1	2	3	4	\$2174.54	\$2207.73	\$2380.20	\$2448.73	\$2764.75	\$2850.48			
						2,3	QBDF-2972-FZN					2228.10	2261.29	2433.76	2502.29	2818.31	2904.04	
						7,8,9	QBDF-2972-FZN					2238.82	2272.01	2444.48	2513.01	2829.03	2914.76	
						K	QBDF-2972-FZN	K				N/A	N/A	2508.74	2577.27	2893.29	2979.02	
					QBDF-2972-FZN	1	2	3	4	\$2174.54	\$2207.73	\$2380.20	\$2448.73	\$2764.75	\$2850.48			
						2,3	QBDF-2972-FZN					2228.10	2261.29	2433.76	2502.29	2818.31	2904.04	
						7,8,9	QBDF-2972-FZN					2238.82	2272.01	2444.48	2513.01	2829.03	2914.76	
						K	QBDF-2972-FZN	K				N/A	N/A	2508.74	2577.27	2893.29	2979.02	
					QBDF-2972-FZN	1	2	3	4	\$2174.54	\$2207.73	\$2380.20	\$2448.73	\$2764.75	\$2850.48			
						2,3	QBDF-2972-FZN					2228.10	2261.29	2433.76	2502.29	2818.31	2904.04	
						7,8,9	QBDF-2972-FZN					2238.82	2272.01	2444.48	2513.01	2829.03	2914.76	
						K	QBDF-2972-FZN	K				N/A	N/A	2508.74	2577.27	2893.29	2979.02	
					QBDF-2972-FZN	1	2	3	4	\$2174.54	\$2207.73	\$2380.20	\$2448.73	\$2764.75	\$2850.48			
						2,3	QBDF-2972-FZN					2228.10	2261.29	2433.76	2502.29	2818.31	2904.04	
						7,8,9	QBDF-2972-FZN					2238.82	2272.01	2444.48	2513.01	2829.03	2914.76	
						K	QBDF-2972-FZN	K				N/A	N/A	2508.74	2577.27	2893.29	2979.02	
					QBDF-2972-FZN	1	2	3	4	\$2174.54	\$2207.73	\$2380.20	\$2448.73	\$2764.75	\$2850.48			
						2,3	QBDF-2972-FZN					2228.10	2261.29	2433.76	2502.29	2818.31	2904.04	
						7,8,9	QBDF-2972-FZN					2238.82	2272.01	2444.48	2513.01	2829.03	2914.76	
						K	QBDF-2972-FZN	K				N/A	N/A	2508.74	2577.27	2893.29	2979.02	

*Finished Height includes worksurface top, spacer, base unit and legs

Base Unit — Open Storage with a Drawer — Double

Description	Finished Height*	Actual Width	Nominal Width	Pull	Number	Case Laminate B				Wood Door Group A	Wood Door Group B	
						Steel Door Trim A	Steel Door Trim B	Laminate Door A	Laminate Door B			
Double 1.5H												
Open — Left Box Drawer/ 12" Open	23"(584mm)	47 7/8"(1216mm)	48"(1219mm)	1, J	QBDF-2348-ZCN	■ ■ ■ ■	\$1210.44	\$1230.78	\$1366.83	\$1422.52	\$1652.84	\$1717.13
				2,3	QBDF-2348-ZCN	■ ■ ■ ■	1237.22	1257.56	1393.61	1449.30	1679.62	1743.91
				7,8,9	QBDF-2348-ZCN	■ ■ ■ ■	1242.58	1262.92	1398.97	1454.66	1684.98	1749.27
				K	QBDF-2348-ZCN	K ■ ■ ■	N/A	N/A	1431.10	1486.79	1717.11	1781.40
				Q	QBDF-2348-ZCN	Q ■ ■ ■	N/A	N/A	1463.24	1518.93	1777.10	1841.39
	59 7/8"(1521mm)	60"(1524mm)		1, J	QBDF-2360-ZCN	■ ■ ■ ■	\$1304.70	\$1329.32	\$1480.37	\$1542.48	\$1804.94	\$1879.95
				2,3	QBDF-2360-ZCN	■ ■ ■ ■	1331.48	1356.10	1507.15	1569.26	1831.72	1906.73
				7,8,9	QBDF-2360-ZCN	■ ■ ■ ■	1336.84	1361.46	1512.51	1574.62	1837.08	1912.09
				K	QBDF-2360-ZCN	K ■ ■ ■	N/A	N/A	1544.64	1606.75	1869.21	1944.22
				Q	QBDF-2360-ZCN	Q ■ ■ ■	N/A	N/A	1576.78	1638.89	1929.20	2004.21
	71 7/8"(1826mm)	72"(1829mm)		1, J	QBDF-2372-ZCN	■ ■ ■ ■	\$1398.96	\$1427.86	\$1593.91	\$1662.44	\$1957.04	\$2042.77
				2,3	QBDF-2372-ZCN	■ ■ ■ ■	1425.74	1454.64	1620.69	1689.22	1983.82	2069.55
				7,8,9	QBDF-2372-ZCN	■ ■ ■ ■	1431.10	1460.00	1626.05	1694.58	1989.18	2074.91
				K	QBDF-2372-ZCN	K ■ ■ ■	N/A	N/A	1658.18	1726.71	2021.31	2107.04
				Q	QBDF-2372-ZCN	Q ■ ■ ■	N/A	N/A	1718.17	1786.70	2081.30	2167.03
Box Drawer/ 12" Open	23"(584mm)	47 7/8"(1216mm)	48"(1219mm)	1, J	QBDF-2348-CZN	■ ■ ■ ■	\$1210.44	\$1230.78	\$1366.83	\$1422.52	\$1652.84	\$1717.13
Open — Right				2,3	QBDF-2348-CZN	■ ■ ■ ■	1237.22	1257.56	1393.61	1449.30	1679.62	1743.91
				7,8,9	QBDF-2348-CZN	■ ■ ■ ■	1242.58	1262.92	1398.97	1454.66	1684.98	1749.27
				K	QBDF-2348-CZN	K ■ ■ ■	N/A	N/A	1431.10	1486.79	1717.11	1781.40
				Q	QBDF-2348-CZN	Q ■ ■ ■	N/A	N/A	1463.24	1518.93	1777.10	1841.39
	59 7/8"(1521mm)	60"(1524mm)		1, J	QBDF-2360-CZN	■ ■ ■ ■	\$1304.70	\$1329.32	\$1480.37	\$1542.48	\$1804.94	\$1879.95
				2,3	QBDF-2360-CZN	■ ■ ■ ■	1331.48	1356.10	1507.15	1569.26	1831.72	1906.73
				7,8,9	QBDF-2360-CZN	■ ■ ■ ■	1336.84	1361.46	1512.51	1574.62	1837.08	1912.09
				K	QBDF-2360-CZN	K ■ ■ ■	N/A	N/A	1544.64	1606.75	1869.21	1944.22
				Q	QBDF-2360-CZN	Q ■ ■ ■	N/A	N/A	1576.78	1638.89	1929.20	2004.21
	71 7/8"(1826mm)	72"(1829mm)		1, J	QBDF-2372-CZN	■ ■ ■ ■	\$1398.96	\$1427.86	\$1593.91	\$1662.44	\$1957.04	\$2042.77
				2,3	QBDF-2372-CZN	■ ■ ■ ■	1425.74	1454.64	1620.69	1689.22	1983.82	2069.55
				7,8,9	QBDF-2372-CZN	■ ■ ■ ■	1431.10	1460.00	1626.05	1694.58	1989.18	2074.91
				K	QBDF-2372-CZN	K ■ ■ ■	N/A	N/A	1658.18	1726.71	2021.31	2107.04
				Q	QBDF-2372-CZN	Q ■ ■ ■	N/A	N/A	1690.32	1758.85	2081.30	2167.03
Open — Left 6" Open/ Lateral File	23"(584mm)	47 7/8"(1216mm)	48"(1219mm)	1, J	QBDF-2348-ZDN	■ ■ ■ ■	\$1633.57	\$1653.91	\$1789.96	\$1845.65	\$2075.97	\$2140.26
				2,3	QBDF-2348-ZDN	■ ■ ■ ■	1660.35	1680.69	1816.74	1872.43	2102.75	2167.04
				7,8,9	QBDF-2348-ZDN	■ ■ ■ ■	1665.71	1686.05	1822.10	1877.79	2108.11	2172.40
				K	QBDF-2348-ZDN	K ■ ■ ■	N/A	N/A	1854.23	1909.92	2140.24	2204.53
				Q	QBDF-2348-ZDN	Q ■ ■ ■	N/A	N/A	1886.37	1942.06	2200.23	2264.52
	59 7/8"(1521mm)	60"(1524mm)		1, J	QBDF-2360-ZDN	■ ■ ■ ■	\$1764.25	\$1788.87	\$1939.92	\$2002.03	\$2264.49	\$2339.50
				2,3	QBDF-2360-ZDN	■ ■ ■ ■	1791.03	1815.65	1966.70	2028.81	2291.27	2366.28
				7,8,9	QBDF-2360-ZDN	■ ■ ■ ■	1796.39	1821.01	1972.06	2034.17	2296.63	2371.64
				K	QBDF-2360-ZDN	K ■ ■ ■	N/A	N/A	2004.19	2066.30	2328.76	2403.77
				Q	QBDF-2360-ZDN	Q ■ ■ ■	N/A	N/A	2036.33	2098.44	2388.75	2463.76
	71 7/8"(1826mm)	72"(1829mm)		1, J	QBDF-2372-ZDN	■ ■ ■ ■	\$1894.93	\$1923.83	\$2089.88	\$2158.41	\$2453.01	\$2538.74
				2,3	QBDF-2372-ZDN	■ ■ ■ ■	1921.71	1950.61	2116.66	2185.19	2479.79	2565.52
				7,8,9	QBDF-2372-ZDN	■ ■ ■ ■	1927.07	1955.97	2122.02	2190.55	2485.15	2570.88
				K	QBDF-2372-ZDN	K ■ ■ ■	N/A	N/A	2154.15	2222.68	2517.28	2603.01
				Q	QBDF-2372-ZDN	Q ■ ■ ■	N/A	N/A	2186.29	2254.82	2577.27	2663.00
6" Open/ Lateral File	23"(584mm)	47 7/8"(1216mm)	48"(1219mm)	1, J	QBDF-2348-DZN	■ ■ ■ ■	\$1633.57	\$1653.91	\$1789.96	\$1845.65	\$2075.97	\$2140.26
Open — Right				2,3	QBDF-2348-DZN	■ ■ ■ ■	1660.35	1680.69	1816.74	1872.43	2102.75	2167.04
				7,8,9	QBDF-2348-DZN	■ ■ ■ ■	1665.71	1686.05	1822.10	1877.79	2108.11	2172.40
				K	QBDF-2348-DZN	K ■ ■ ■	N/A	N/A	1854.23	1909.92	2140.24	2204.53
				Q	QBDF-2348-DZN	Q ■ ■ ■	N/A	N/A	1886.37	1942.06	2200.23	2264.52
	59 7/8"(1521mm)	60"(1524mm)		1, J	QBDF-2360-DZN	■ ■ ■ ■	\$1764.25	\$1788.87	\$1939.92	\$2002.03	\$2264.49	\$2339.50
				2,3	QBDF-2360-DZN	■ ■ ■ ■	1791.03	1815.65	1966.70	2028.81	2291.27	2366.28
				7,8,9	QBDF-2360-DZN	■ ■ ■ ■	1796.39	1821.01	1972.06	2034.17	2296.63	2371.64
				K	QBDF-2360-DZN	K ■ ■ ■	N/A	N/A	2004.19	2066.30	2328.76	2403.77
				Q	QBDF-2360-DZN	Q ■ ■ ■	N/A	N/A	2036.33	2098.44	2388.75	2463.76
	71 7/8"(1826mm)	72"(1829mm)		1, J	QBDF-2372-DZN	■ ■ ■ ■	\$1894.93	\$1923.83	\$2089.88	\$2158.41	\$2453.01	\$2538.74
				2,3	QBDF-2372-DZN	■ ■ ■ ■	1921.71	1950.61	2116.66	2185.19	2479.79	2565.52
				7,8,9	QBDF-2372-DZN	■ ■ ■ ■	1927.07	1955.97	2122.02	2190.55	2485.15	2570.88
				K	QBDF-2372-DZN	K ■ ■ ■	N/A	N/A	2154.15	2222.68	2517.28	2603.01
				Q	QBDF-2372-DZN	Q ■ ■ ■	N/A	N/A	2186.29	2254.82	2577.27	2663.00

*Finished Height includes worksurface top, spacer, base unit and legs

Base Unit — Open Storage with a Drawer — Double

Description	Finished Height*	Actual Width	Nominal Width	Pull	Number	Case Laminate B				Wood Door		
						Steel Door Trim A	Trim B	Laminate Door A	Door B	Group A	Group B	
Double 2H												
Open — Left Box Drawer/ 18" Open	29"(737mm)	47 7/8"(1216mm)	48"(1219mm)	1,J	QBDF-2948-ZCN	■ ■ ■ ■	\$1495.39	\$1520.02	\$1662.49	\$1718.18	\$1969.92	\$2034.21
				2,3	QBDF-2948-ZCN	■ ■ ■ ■	1522.17	1546.80	1689.27	1744.96	1996.70	2060.99
				7,8,9	QBDF-2948-ZCN	■ ■ ■ ■	1527.53	1552.16	1694.63	1750.32	2002.06	2066.35
				K	QBDF-2948-ZCN	K ■ ■ ■	N/A	N/A	1726.76	1782.45	2034.19	2098.48
				Q	QBDF-2948-ZCN	Q ■ ■ ■	N/A	N/A	1758.90	1814.59	2066.33	2130.62
	59 7/8"(1521mm)	60"(1524mm)		1,J	QBDF-2960-ZCN	■ ■ ■ ■	\$1589.65	\$1618.56	\$1776.03	\$1838.14	\$2122.02	\$2197.03
				2,3	QBDF-2960-ZCN	■ ■ ■ ■	1616.43	1645.34	1802.81	1864.92	2148.80	2223.81
				7,8,9	QBDF-2960-ZCN	■ ■ ■ ■	1621.79	1650.70	1808.17	1870.28	2154.16	2229.17
				K	QBDF-2960-ZCN	K ■ ■ ■	N/A	N/A	1840.30	1902.41	2186.29	2261.30
				Q	QBDF-2960-ZCN	Q ■ ■ ■	N/A	N/A	1872.44	1934.55	2218.43	2293.44
	71 7/8"(1826mm)	72"(1829mm)		1,J	QBDF-2972-ZCN	■ ■ ■ ■	\$1683.91	\$1717.10	\$1889.57	\$1958.10	\$2274.12	\$2359.85
				2,3	QBDF-2972-ZCN	■ ■ ■ ■	1710.69	1743.88	1916.35	1984.88	2300.90	2386.63
				7,8,9	QBDF-2972-ZCN	■ ■ ■ ■	1716.05	1749.24	1921.71	1990.24	2306.26	2391.99
				K	QBDF-2972-ZCN	K ■ ■ ■	N/A	N/A	1953.84	2022.37	2338.39	2424.12
				Q	QBDF-2972-ZCN	Q ■ ■ ■	N/A	N/A	1985.98	2054.51	2370.53	2456.26
Box Drawer/ 18" Open	29"(737mm)	47 7/8"(1216mm)	48"(1219mm)	1,J	QBDF-2948-CZN	■ ■ ■ ■	\$1495.39	\$1520.02	\$1662.49	\$1718.18	\$1969.92	\$2034.21
Open — Right				2,3	QBDF-2948-CZN	■ ■ ■ ■	1522.17	1546.80	1689.27	1744.96	1996.70	2060.99
				7,8,9	QBDF-2948-CZN	■ ■ ■ ■	1527.53	1552.16	1694.63	1750.32	2002.06	2066.35
				K	QBDF-2948-CZN	K ■ ■ ■	N/A	N/A	1726.76	1782.45	2034.19	2098.48
				Q	QBDF-2948-CZN	Q ■ ■ ■	N/A	N/A	1758.90	1814.59	2066.33	2130.62
	59 7/8"(1521mm)	60"(1524mm)		1,J	QBDF-2960-CZN	■ ■ ■ ■	\$1589.65	\$1618.56	\$1776.03	\$1838.14	\$2122.02	\$2197.03
				2,3	QBDF-2960-CZN	■ ■ ■ ■	1616.43	1645.34	1802.81	1864.92	2148.80	2223.81
				7,8,9	QBDF-2960-CZN	■ ■ ■ ■	1621.79	1650.70	1808.17	1870.28	2154.16	2229.17
				K	QBDF-2960-CZN	K ■ ■ ■	N/A	N/A	1840.30	1902.41	2186.29	2261.30
				Q	QBDF-2960-CZN	Q ■ ■ ■	N/A	N/A	1872.44	1934.55	2218.43	2293.44
	71 7/8"(1826mm)	72"(1829mm)		1,J	QBDF-2972-CZN	■ ■ ■ ■	\$1683.91	\$1717.10	\$1889.57	\$1958.10	\$2274.12	\$2359.85
				2,3	QBDF-2972-CZN	■ ■ ■ ■	1710.69	1743.88	1916.35	1984.88	2300.90	2386.63
				7,8,9	QBDF-2972-CZN	■ ■ ■ ■	1716.05	1749.24	1921.71	1990.24	2306.26	2391.99
				K	QBDF-2972-CZN	K ■ ■ ■	N/A	N/A	1953.84	2022.37	2338.39	2424.12
				Q	QBDF-2972-CZN	Q ■ ■ ■	N/A	N/A	1985.98	2054.51	2370.53	2456.26
Open — Left 12" Open/ Lateral File	29"(737mm)	47 7/8"(1216mm)	48"(1219mm)	1,J	QBDF-2948-ZDN	■ ■ ■ ■	\$1881.02	\$1905.65	\$2048.12	\$2103.81	\$2355.55	\$2419.84
				2,3	QBDF-2948-ZDN	■ ■ ■ ■	1907.80	1932.43	2074.90	2130.59	2382.33	2446.62
				7,8,9	QBDF-2948-ZDN	■ ■ ■ ■	1913.16	1937.79	2080.26	2135.95	2387.69	2451.98
				K	QBDF-2948-ZDN	K ■ ■ ■	N/A	N/A	2112.39	2168.08	2419.82	2484.11
				Q	QBDF-2948-ZDN	Q ■ ■ ■	N/A	N/A	2144.53	2200.22	2451.96	2516.25
	59 7/8"(1521mm)	60"(1524mm)		1,J	QBDF-2960-ZDN	■ ■ ■ ■	\$2026.70	\$2055.61	\$2213.08	\$2275.19	\$2559.07	\$2634.08
				2,3	QBDF-2960-ZDN	■ ■ ■ ■	2053.48	2082.39	2239.86	2301.97	2585.85	2660.86
				7,8,9	QBDF-2960-ZDN	■ ■ ■ ■	2058.84	2087.75	2245.22	2307.33	2591.21	2666.22
				K	QBDF-2960-ZDN	K ■ ■ ■	N/A	N/A	2277.35	2339.46	2623.34	2698.35
				Q	QBDF-2960-ZDN	Q ■ ■ ■	N/A	N/A	2309.49	2371.60	2655.48	2730.49
	71 7/8"(1826mm)	72"(1829mm)		1,J	QBDF-2972-ZDN	■ ■ ■ ■	\$2172.38	\$2205.57	\$2378.04	\$2446.57	\$2762.59	\$2848.32
				2,3	QBDF-2972-ZDN	■ ■ ■ ■	2199.16	2232.35	2404.82	2473.35	2789.37	2875.10
				7,8,9	QBDF-2972-ZDN	■ ■ ■ ■	2204.52	2237.71	2410.18	2478.71	2794.73	2880.46
				K	QBDF-2972-ZDN	K ■ ■ ■	N/A	N/A	2442.31	2510.84	2826.86	2912.59
				Q	QBDF-2972-ZDN	Q ■ ■ ■	N/A	N/A	2474.45	2542.98	2859.00	2944.73
12" Open/ Lateral File	29"(737mm)	47 7/8"(1216mm)	48"(1219mm)	1,J	QBDF-2948-DZN	■ ■ ■ ■	\$1881.02	\$1905.65	\$2048.12	\$2103.81	\$2355.55	\$2419.84
Open — Right				2,3	QBDF-2948-DZN	■ ■ ■ ■	1907.80	1932.43	2074.90	2130.59	2382.33	2446.62
				7,8,9	QBDF-2948-DZN	■ ■ ■ ■	1913.16	1937.79	2080.26	2135.95	2387.69	2451.98
				K	QBDF-2948-DZN	K ■ ■ ■	N/A	N/A	2112.39	2168.08	2419.82	2484.11
				Q	QBDF-2948-DZN	Q ■ ■ ■	N/A	N/A	2144.53	2200.22	2451.96	2516.25
	59 7/8"(1521mm)	60"(1524mm)		1,J	QBDF-2960-DZN	■ ■ ■ ■	\$2026.70	\$2055.61	\$2213.08	\$2275.19	\$2559.07	\$2634.08
				2,3	QBDF-2960-DZN	■ ■ ■ ■	2053.48	2082.39	2239.86	2301.97	2585.85	2660.86
				7,8,9	QBDF-2960-DZN	■ ■ ■ ■	2058.84	2087.75	2245.22	2307.33	2591.21	2666.22
				K	QBDF-2960-DZN	K ■ ■ ■	N/A	N/A	2277.35	2339.46	2623.34	2698.35
				Q	QBDF-2960-DZN	Q ■ ■ ■	N/A	N/A	2309.49	2371.60	2655.48	2730.49
	71 7/8"(1826mm)	72"(1829mm)		1,J	QBDF-2972-DZN	■ ■ ■ ■	\$2172.38	\$2205.57	\$2378.04	\$2446.57	\$2762.59	\$2848.32
				2,3	QBDF-2972-DZN	■ ■ ■ ■	2199.16	2232.35	2404.82	2473.35	2789.37	2875.10
				7,8,9	QBDF-2972-DZN	■ ■ ■ ■	2204.52	2237.71	2410.18	2478.71	2794.73	2880.46
				K	QBDF-2972-DZN	K ■ ■ ■	N/A	N/A	2442.31	2510.84	2826.86	2912.59
				Q	QBDF-2972-DZN	Q ■ ■ ■	N/A	N/A	2474.45	2542.98	2859.00	2944.73

*Finished Height includes worksurface top, spacer, base unit and legs

Base Unit — Open Storage with a Drawer — Double

Description	Finished Height*	Actual Width	Nominal Width	Pull	Number	Case Laminate B				Steel Door Trim A	Steel Door Trim B	Laminate Door A	Laminate Door B	Wood Door Group A	Wood Door Group B		
						①	②	③	④								
Open — Left 6" Open/ Box Drawer/ Lateral File	29"(737mm)	47 7/8"(1216mm)	48"(1219mm)	1, J	QBDF-2948-ZFN	■	■	■	■	\$1950.65	\$1975.28	\$2117.75	\$2173.44	\$2425.18	\$2489.47		
						2,3	QBDF-2948-ZFN	■	■	■	■	2004.21	2028.84	2171.31	2227.00	2478.74	2543.03
						7,8,9	QBDF-2948-ZFN	■	■	■	■	2014.93	2039.56	2182.03	2237.72	2489.46	2553.75
						K	QBDF-2948-ZFN	■	K	■	■	N/A	N/A	2246.29	2301.98	2553.72	2618.01
						Q	QBDF-2948-ZFN	■	Q	■	■	N/A	N/A	2310.57	2366.26	2618.00	2682.29
	59 7/8"(1521mm)	60"(1524mm)		1, J	QBDF-2960-ZFN	■	■	■	■	\$2098.47	\$2127.38	\$2284.85	\$2346.96	\$2630.84	\$2705.85		
						2,3	QBDF-2960-ZFN	■	■	■	■	2152.03	2180.94	2338.41	2400.52	2684.40	2759.41
						7,8,9	QBDF-2960-ZFN	■	■	■	■	2162.75	2191.66	2349.13	2411.24	2695.12	2770.13
						K	QBDF-2960-ZFN	■	K	■	■	N/A	N/A	2413.39	2475.50	2759.38	2834.39
						Q	QBDF-2960-ZFN	■	Q	■	■	N/A	N/A	2477.67	2539.78	2823.66	2898.67
	71 7/8"(1826mm)	72"(1829mm)		1, J	QBDF-2972-ZFN	■	■	■	■	\$2246.29	\$2279.48	\$2451.95	\$2520.48	\$2836.50	\$2922.23		
						2,3	QBDF-2972-ZFN	■	■	■	■	2299.85	2333.04	2505.51	2574.04	2890.06	2975.79
						7,8,9	QBDF-2972-ZFN	■	■	■	■	2310.57	2343.76	2516.23	2584.76	2900.78	2986.51
						K	QBDF-2972-ZFN	■	K	■	■	N/A	N/A	2580.49	2649.02	2965.04	3050.77
						Q	QBDF-2972-ZFN	■	Q	■	■	N/A	N/A	2644.77	2713.30	3029.32	3115.05
6" Open/ Box Drawer/ Lateral File Open — Right	29"(737mm)	47 7/8"(1216mm)	48"(1219mm)	1, J	QBDF-2948-FZN	■	■	■	■	\$1950.65	\$1975.28	\$2117.75	\$2173.44	\$2425.18	\$2489.47		
						2,3	QBDF-2948-FZN	■	■	■	■	2004.21	2028.84	2171.31	2227.00	2478.74	2543.03
						7,8,9	QBDF-2948-FZN	■	■	■	■	2014.93	2039.56	2182.03	2237.72	2489.46	2553.75
						K	QBDF-2948-FZN	■	K	■	■	N/A	N/A	2246.29	2301.98	2553.72	2618.01
						Q	QBDF-2948-FZN	■	Q	■	■	N/A	N/A	2310.57	2366.26	2618.00	2682.29
	59 7/8"(1521mm)	60"(1524mm)		1, J	QBDF-2960-FZN	■	■	■	■	\$2098.47	\$2127.38	\$2284.85	\$2346.96	\$2630.84	\$2705.85		
						2,3	QBDF-2960-FZN	■	■	■	■	2152.03	2180.94	2338.41	2400.52	2684.40	2759.41
						7,8,9	QBDF-2960-FZN	■	■	■	■	2162.75	2191.66	2349.13	2411.24	2695.12	2770.13
						K	QBDF-2960-FZN	■	K	■	■	N/A	N/A	2413.39	2475.50	2759.38	2834.39
						Q	QBDF-2960-FZN	■	Q	■	■	N/A	N/A	2477.67	2539.78	2823.66	2898.67
	71 7/8"(1826mm)	72"(1829mm)		1, J	QBDF-2972-FZN	■	■	■	■	\$2246.29	\$2279.48	\$2451.95	\$2520.48	\$2836.50	\$2922.23		
						2,3	QBDF-2972-FZN	■	■	■	■	2299.85	2333.04	2505.51	2574.04	2890.06	2975.79
						7,8,9	QBDF-2972-FZN	■	■	■	■	2310.57	2343.76	2516.23	2584.76	2900.78	2986.51
						K	QBDF-2972-FZN	■	K	■	■	N/A	N/A	2580.49	2649.02	2965.04	3050.77
						Q	QBDF-2972-FZN	■	Q	■	■	N/A	N/A	2644.77	2713.30	3029.32	3115.05

*Finished Height includes worksurface top, spacer, base unit and legs

This page intentionally blank

Base Unit — Drawer Combinations — Single

Drawer Combinations — Single

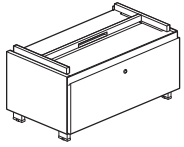

QBSF-ANN

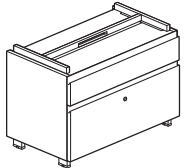

QBSF-BNN

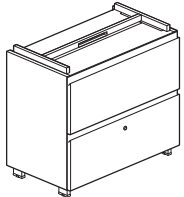

QBSF-ENN

2 Pull Styles

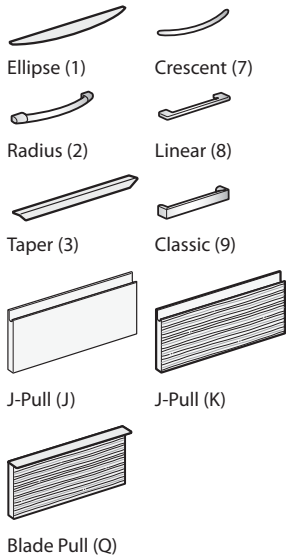

Features

- Open Storage with a drawer include:
 - Laminate end panel and inner top.
 - Painted Steel inner back and bottom.
 - Painted Steel spacer.
- Leg Options:
 - Straight Leg (F)
 - Chamfer Leg (P)
- Glide adjustment range:
 - Straight Leg: 1.5”(38mm)
 - Chamfer Leg: 1.25”(32mm)
- Spacer:
 - 1.18”(30mm) high
 - End pieces come in specified color; center spacer section black only.
- Drawer interior is black.
- Lateral file includes side-to-side filing bar.
- Full extension drawers.
- Optional drawer fronts include painted steel, laminate or wood.
- Ellipse pull available in non-metallic color only. (see finish page for pull color)
- Radius pull available in metallic colors only. (see finish page for pull color)
- J-Pull (J) matches painted steel front.
- J-Pull (K) or Blade Pull (Q) available on laminate or wood fronts only. Must specify color.
- Lock Options:
 - Locking (chrome only) and non-locking available.
 - One lock accommodates all drawers.
- Shelves are separately specified; not included with unit.
- Case ships assembled. Legs require field installation.

Specification Tips

- Designed to be used with Haworth's Integrated Palette, UniGroup Too, PREMISE, Reside Desking and/or Belong Work Tools.
- All base units with drawers must be attached. Refer to Specification Guide for planning information.
- Separately specified storage tops are required and can match the width of a single base unit or span two or more adjacent base units side by side.
- To route and access power in storage, order separately specified Belong power components.
- 1.5H and 2H storage can be used to support Reside desking or Adaptable worksurfaces in a perpendicular configuration with separately specified brackets. Refer to Specification Guide for planning information.
- Beside base storage unit with top, spacer, base unit and legs finished heights:
 - 1H = 17”(432mm)
 - 1.5H = 23”(584mm)
 - 2H = 29”(737mm)
- Separately specified if applicable:
 - Belong Power and communication cabling, tools, screens and tool rails.
 - Storage-to-Panel Bracket
 - Storage Attachment Bracket
 - Ganging Bracket
 - Storage Top (required)
 - Filler Panel
 - Top Filler Track
 - Finished Back (recommended when back is exposed)
 - Adjustable Shelf (not included with unit)
 - Stack-On Hutch
 - Front-to-Back Filing Bars
- Refer to Specification Guide for planning information and actual dimensions.

Notes: 2H storage base units are not designed to fit under Reside benching or return worksurfaces. Reside Desking or Adaptable worksurfaces can be attached to the front or back of a 2H Beside storage unit with separately specified flush mount plates.

Separately specified Belong base unit power components available for 30”-72”(372mm-1829mm) widths only.

1H units cannot accept binders.

To Order, Specify:

Steel Drawer Front

- 1) Product number, including:

1 Steel Drawer Front Option:

S Steel

2 Pull Option: (see side bar)

3 Leg Option:

F Straight Leg

P Chamfer Leg, add **\$85.70** list

4 Lock Option:

L Locking, add **\$42.85** list

N Non-Locking

- 2) Case laminate color.

- 3) Case laminate edgeband color.

- 4) Bottom, inset back and fixed shelf trim color.

- 5) Pull, leg and spacer trim color.

- 6) Drawer front steel color.

Laminate or Wood Drawer Front

- 1) Product number, including:

1 Laminate or Wood Drawer Front Option:

L Laminate

W Wood

2 Pull Option: (see side bar)

3 Leg Option:

F Straight Leg

P Chamfer Leg, add **\$85.70** list

4 Lock Option:

L Locking, add **\$42.85** list

N Non-Locking

- 2) Case laminate color.

- 3) Case laminate edgeband color.

- 4) Bottom, inset back and fixed shelf trim color.

- 5) Pull, leg and spacer trim color.

- 6) Drawer front laminate or wood color.

- 7) Laminate drawer front edgeband color.

Note: Upcharge for mixed grade fabric or trim surfaces, refer to the electronic design and specification tools for pricing.

Base Unit — Drawer Combinations — Single

Description	Finished Height*	Actual Width	Nominal Width	Pull	Number	Case Laminate A				Steel Door		Laminate Door		Wood Door	
						1	2	3	4	Trim A	Trim B	A	B	Group A	Group B
Single 1H															
Lateral File	17"(432mm)	23 7/8"(606mm)	24"(610mm)	1, J	QBSF-1724-ANN	■	■	■	■	\$1146.19	\$1153.69	\$1253.31	\$1296.16	\$1440.77	\$1483.62
				2,3	QBSF-1724-ANN	■	■	■	■	1172.97	1180.47	1280.09	1322.94	1467.55	1510.40
				7,8,9	QBSF-1724-ANN	■	■	■	■	1178.33	1185.83	1285.45	1328.30	1472.91	1515.76
				K	QBSF-1724-ANN	■	K	■	■	N/A	N/A	1317.58	1360.43	1505.04	1547.89
				Q	QBSF-1724-ANN	■	Q	■	■	N/A	N/A	1349.72	1392.57	1537.18	1580.03
		29 7/8"(759mm)	30"(762mm)	1, J	QBSF-1730-ANN	■	■	■	■	\$1205.10	\$1214.74	\$1321.86	\$1367.92	\$1528.60	\$1576.81
				2,3	QBSF-1730-ANN	■	■	■	■	1231.88	1241.52	1348.64	1394.70	1555.38	1603.59
				7,8,9	QBSF-1730-ANN	■	■	■	■	1237.24	1246.88	1354.00	1400.06	1560.74	1608.95
				K	QBSF-1730-ANN	■	K	■	■	N/A	N/A	1386.13	1432.19	1592.87	1641.08
				Q	QBSF-1730-ANN	■	Q	■	■	N/A	N/A	1418.27	1464.33	1625.01	1673.22
		35 7/8"(911mm)	36"(914mm)	1, J	QBSF-1736-ANN	■	■	■	■	\$1264.01	\$1275.79	\$1390.41	\$1439.68	\$1616.43	\$1670.00
				2,3	QBSF-1736-ANN	■	■	■	■	1290.79	1302.57	1417.19	1466.46	1643.21	1696.78
				7,8,9	QBSF-1736-ANN	■	■	■	■	1296.15	1307.93	1422.55	1471.82	1648.57	1702.14
				K	QBSF-1736-ANN	■	K	■	■	N/A	N/A	1454.68	1503.95	1680.70	1734.27
				Q	QBSF-1736-ANN	■	Q	■	■	N/A	N/A	1486.82	1536.09	1712.84	1766.41
Single 1.5H															
Box Drawer/ Lateral File	23"(584mm)	23 7/8"(606mm)	24"(610mm)	1, J	QBSF-2324-BNN	■	■	■	■	\$1269.38	\$1281.16	\$1387.21	\$1430.06	\$1596.10	\$1638.95
				2,3	QBSF-2324-BNN	■	■	■	■	1322.94	1334.72	1440.77	1483.62	1649.66	1692.51
				7,8,9	QBSF-2324-BNN	■	■	■	■	1333.66	1345.44	1451.49	1494.34	1660.38	1703.23
				K	QBSF-2324-BNN	■	K	■	■	N/A	N/A	1515.75	1558.60	1724.64	1767.49
				Q	QBSF-2324-BNN	■	Q	■	■	N/A	N/A	1580.03	1622.88	1788.92	1831.77
		29 7/8"(759mm)	30"(762mm)	1, J	QBSF-2330-BNN	■	■	■	■	\$1355.07	\$1368.99	\$1482.54	\$1528.60	\$1710.71	\$1758.92
				2,3	QBSF-2330-BNN	■	■	■	■	1408.63	1422.55	1536.10	1582.16	1764.27	1812.48
				7,8,9	QBSF-2330-BNN	■	■	■	■	1419.35	1433.27	1546.82	1592.88	1774.99	1823.20
				K	QBSF-2330-BNN	■	K	■	■	N/A	N/A	1611.08	1657.14	1839.25	1887.46
				Q	QBSF-2330-BNN	■	Q	■	■	N/A	N/A	1675.36	1721.42	1903.53	1951.74
		35 7/8"(911mm)	36"(914mm)	1, J	QBSF-2336-BNN	■	■	■	■	\$1440.76	\$1456.82	\$1577.87	\$1627.14	\$1825.32	\$1878.89
				2,3	QBSF-2336-BNN	■	■	■	■	1494.32	1510.38	1631.43	1680.70	1878.88	1932.45
				7,8,9	QBSF-2336-BNN	■	■	■	■	1505.04	1521.10	1642.15	1691.42	1889.60	1943.17
				K	QBSF-2336-BNN	■	K	■	■	N/A	N/A	1706.41	1755.68	1953.86	2007.43
				Q	QBSF-2336-BNN	■	Q	■	■	N/A	N/A	1770.69	1819.96	2018.14	2071.71
Single 2H															
Lateral File/ Lateral File	29"(737mm)	23 7/8"(606mm)	24"(610mm)	1, J	QBSF-2924-ENN	■	■	■	■	\$1361.50	\$1377.57	\$1490.04	\$1532.89	\$1720.35	\$1763.20
				2,3	QBSF-2924-ENN	■	■	■	■	1415.06	1431.13	1543.60	1586.45	1773.91	1816.76
				7,8,9	QBSF-2924-ENN	■	■	■	■	1425.78	1441.85	1554.32	1597.17	1784.63	1827.48
				K	QBSF-2924-ENN	■	K	■	■	N/A	N/A	1618.58	1661.43	1848.89	1891.74
				Q	QBSF-2924-ENN	■	Q	■	■	N/A	N/A	1682.86	1725.71	1913.17	1956.02
		29 7/8"(759mm)	30"(762mm)	1, J	QBSF-2930-ENN	■	■	■	■	\$1443.98	\$1462.19	\$1582.16	\$1628.22	\$1831.75	\$1879.96
				2,3	QBSF-2930-ENN	■	■	■	■	1497.54	1515.75	1635.72	1681.78	1885.31	1933.52
				7,8,9	QBSF-2930-ENN	■	■	■	■	1508.26	1526.47	1646.44	1692.50	1896.03	1944.24
				K	QBSF-2930-ENN	■	K	■	■	N/A	N/A	1710.70	1756.76	1960.29	2008.50
				Q	QBSF-2930-ENN	■	Q	■	■	N/A	N/A	1774.98	1821.04	2024.57	2072.78
		35 7/8"(911mm)	36"(914mm)	1, J	QBSF-2936-ENN	■	■	■	■	\$1526.46	\$1546.81	\$1674.28	\$1723.55	\$1943.15	\$1996.72
				2,3	QBSF-2936-ENN	■	■	■	■	1580.02	1600.37	1727.84	1777.11	1996.71	2050.28
				7,8,9	QBSF-2936-ENN	■	■	■	■	1590.74	1611.09	1738.56	1787.83	2007.43	2061.00
				K	QBSF-2936-ENN	■	K	■	■	N/A	N/A	1802.82	1852.09	2071.69	2125.26
				Q	QBSF-2936-ENN	■	Q	■	■	N/A	N/A	1867.10	1916.37	2135.97	2189.54

*Finished Height includes worksurface top, spacer, base unit and legs

Base Unit — Drawer Combinations — Single

Description	Finished Height*	Actual Width	Nominal Width	Pull	Number	Case Laminate B				Laminate Door A	Laminate Door B	Wood Door			
						Steel Door Trim A	Trim B	Group A	Group B						
Single 1H															
Lateral File	17"(432mm)	23 7/8"(606mm)	24"(610mm)	1, J	QBSF-1724-ANN	1	2	3	4	\$1187.97	\$1195.47	\$1295.09	\$1337.94	\$1482.55	\$1525.40
						2,3	QBSF-1724-ANN	1214.75	1222.25	1321.87	1364.72	1509.33	1552.18		
						7,8,9	QBSF-1724-ANN	1220.11	1227.61	1327.23	1370.08	1514.69	1557.54		
						K	QBSF-1724-ANN	N/A	N/A	1359.36	1402.21	1546.82	1589.67		
						Q	QBSF-1724-ANN	N/A	N/A	1391.50	1434.35	1578.96	1621.81		
	29 7/8"(759mm)	30"(762mm)	1, J	QBSF-1730-ANN	1	2	3	4	\$1249.02	\$1258.66	\$1365.78	\$1411.84	\$1572.52	\$1620.73	
					2,3	QBSF-1730-ANN	1275.80	1285.44	1392.56	1438.62	1599.30	1647.51			
					7,8,9	QBSF-1730-ANN	1281.16	1290.80	1397.92	1443.98	1604.66	1652.87			
					K	QBSF-1730-ANN	N/A	N/A	1430.05	1476.11	1636.79	1685.00			
					Q	QBSF-1730-ANN	N/A	N/A	1462.19	1508.25	1668.93	1717.14			
	35 7/8"(911mm)	36"(914mm)	1, J	QBSF-1736-ANN	1	2	3	4	\$1310.07	\$1321.85	\$1436.47	\$1485.74	\$1662.49	\$1716.06	
					2,3	QBSF-1736-ANN	1336.85	1348.63	1463.25	1512.52	1689.27	1742.84			
					7,8,9	QBSF-1736-ANN	1342.21	1353.99	1468.61	1517.88	1694.63	1748.20			
					K	QBSF-1736-ANN	N/A	N/A	1500.74	1550.01	1726.76	1780.33			
					Q	QBSF-1736-ANN	N/A	N/A	1532.88	1582.15	1758.90	1812.47			
Single 1.5H															
Box Drawer/ Lateral File	23"(584mm)	23 7/8"(606mm)	24"(610mm)	1, J	QBSF-2324-BNN	1	2	3	4	\$1317.58	\$1329.36	\$1435.41	\$1478.26	\$1644.30	\$1687.15
						2,3	QBSF-2324-BNN	1371.14	1382.92	1488.97	1531.82	1697.86	1740.71		
						7,8,9	QBSF-2324-BNN	1381.86	1393.64	1499.69	1542.54	1708.58	1751.43		
						K	QBSF-2324-BNN	N/A	N/A	1563.95	1606.80	1772.84	1815.69		
						Q	QBSF-2324-BNN	N/A	N/A	1628.23	1671.08	1837.12	1879.97		
	29 7/8"(759mm)	30"(762mm)	1, J	QBSF-2330-BNN	1	2	3	4	\$1405.41	\$1419.33	\$1532.88	\$1578.94	\$1761.05	\$1809.26	
					2,3	QBSF-2330-BNN	1458.97	1472.89	1586.44	1632.50	1814.61	1862.82			
					7,8,9	QBSF-2330-BNN	1469.69	1483.61	1597.16	1643.22	1825.33	1873.54			
					K	QBSF-2330-BNN	N/A	N/A	1661.42	1707.48	1889.59	1937.80			
					Q	QBSF-2330-BNN	N/A	N/A	1725.70	1771.76	1953.87	2002.08			
	35 7/8"(911mm)	36"(914mm)	1, J	QBSF-2336-BNN	1	2	3	4	\$1493.24	\$1509.30	\$1630.35	\$1679.62	\$1877.80	\$1931.37	
					2,3	QBSF-2336-BNN	1546.80	1562.86	1683.91	1733.18	1931.36	1984.93			
					7,8,9	QBSF-2336-BNN	1557.52	1573.58	1694.63	1743.90	1942.08	1995.65			
					K	QBSF-2336-BNN	N/A	N/A	1758.89	1808.16	2006.34	2059.91			
					Q	QBSF-2336-BNN	N/A	N/A	1823.17	1872.44	2070.62	2124.19			
Single 2H															
Lateral File/ Lateral File	29"(737mm)	23 7/8"(606mm)	24"(610mm)	1, J	QBSF-2924-ENN	1	2	3	4	\$1416.13	\$1432.20	\$1544.67	\$1587.52	\$1774.98	\$1817.83
						2,3	QBSF-2924-ENN	1469.69	1485.76	1598.23	1641.08	1828.54	1871.39		
						7,8,9	QBSF-2924-ENN	1480.41	1496.48	1608.95	1651.80	1839.26	1882.11		
						K	QBSF-2924-ENN	N/A	N/A	1673.21	1716.06	1903.52	1946.37		
						Q	QBSF-2924-ENN	N/A	N/A	1737.49	1780.34	1967.80	2010.65		
	29 7/8"(759mm)	30"(762mm)	1, J	QBSF-2930-ENN	1	2	3	4	\$1500.75	\$1518.96	\$1638.93	\$1684.99	\$1888.52	\$1936.73	
					2,3	QBSF-2930-ENN	1554.31	1572.52	1692.49	1738.55	1942.08	1990.29			
					7,8,9	QBSF-2930-ENN	1565.03	1583.24	1703.21	1749.27	1952.80	2001.01			
					K	QBSF-2930-ENN	N/A	N/A	1767.47	1813.53	2017.06	2065.27			
					Q	QBSF-2930-ENN	N/A	N/A	1831.75	1877.81	2081.34	2129.55			
	35 7/8"(911mm)	36"(914mm)	1, J	QBSF-2936-ENN	1	2	3	4	\$1585.37	\$1605.72	\$1733.19	\$1782.46	\$2002.06	\$2055.63	
					2,3	QBSF-2936-ENN	1638.93	1659.28	1786.75	1836.02	2055.62	2109.19			
					7,8,9	QBSF-2936-ENN	1649.65	1670.00	1797.47	1846.74	2066.34	2119.91			
					K	QBSF-2936-ENN	N/A	N/A	1861.73	1911.00	2130.60	2184.17			
					Q	QBSF-2936-ENN	N/A	N/A	1926.01	1975.28	2194.88	2248.45			

*Finished Height includes worksurface top, spacer, base unit and legs

This page intentionally blank

Base Unit — Drawer Combinations — Double

Drawer Combinations — Double

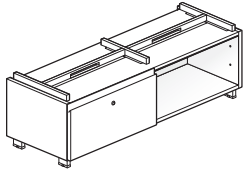

QBDF-XXXX-AZN

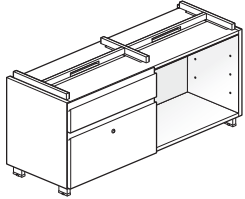

QBDF-XXXX-BZN

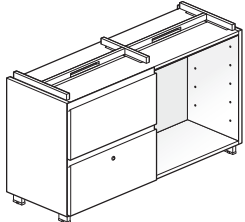

QBDF-XXXX-EZN

2 Pull Styles

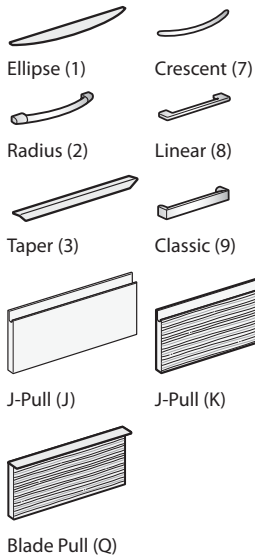

Features

- Open Storage with a drawer include:
 - Laminate end panel and inner top.
 - Painted Steel inner back and bottom.
 - Painted Steel spacer.
- Leg Options:
 - Straight Leg (F)
 - Chamfer Leg (P)
- Glide adjustment range:
 - Straight Leg: 1.5”(38 mm)
 - Chamfer Leg: 1.25”(32mm)
- Spacer:
 - 1.18”(30mm) high
 - End pieces come in specified color; center spacer section black only.
- Drawer interior is black.
- Lateral file includes side-to-side filing bar.
- Full extension drawers.
- Optional drawer fronts include painted steel, laminate or wood.
- Ellipse pull available in non-metallic color only. (see finish page for pull color)
- Radius pull available in metallic colors only. (see finish page for pull color)
- J-Pull (J) matches painted steel fronts.
- J-Pull (K) or Blade Pull (Q) available on laminate or wood fronts only.
- Lock Options:
 - Locking (chrome only) and non-locking available.
 - One lock accommodates all drawers.
- Shelves are separately specified; not included with unit.
- Case ships assembled. Legs require field installation.

Specification Tips

- Designed to be used with Haworth’s Integrated Palette, UniGroup Too, PREMISE, Reside Desking and/or Belong Work Tools.
- All base units with drawers must be attached. Refer to Specification Guide for planning information.
- Separately specified storage tops are required and can match the width of a single base unit or span two or more adjacent base units side by side.
- To route and access power in storage, order separately specified Belong power components.
- 1.5H and 2H storage can be used to support Reside desking or Adaptable worksurfaces in a perpendicular configuration with separately specified brackets. Refer to Specification Guide for planning information.
- Beside base storage unit with top, spacer, base unit and legs finished heights:
 - 1H = 17”(432mm)
 - 1.5H = 23”(584mm)
 - 2H = 29”(737mm)
- Separately specified if applicable:
 - Belong Power and communication cabling, tools, screens and tool rails.
 - Storage-to-Panel Bracket
 - Storage Attachment Bracket
 - Ganging Bracket
 - Storage Top (required)
 - Filler Panel
 - Top Filler Track
 - Finished Back (recommended when back is exposed)
 - Adjustable Shelf (not included with unit)
 - Stack-On Hutch
 - Front-to-Back Filing Bars
- Refer to Specification Guide for planning information and actual dimensions.

Notes: 2H storage base units are not designed to fit under Reside benching or return worksurfaces. They can only attach to these surfaces.

Separately specified Belong base unit power components available for 30- 72”(372mm-1829mm) widths only.

Storage shelves are unique to the specific base unit configuration. Refer to shelf price list pages for appropriate shelf.

1H units cannot accept binders.

To Order, Specify:

Steel Drawer Front

1) Product number, including:

1 Steel Drawer Front Option:

S Steel

2 Pull Option: (side bar)

3 Leg Option:

F Straight Leg

P Chamfer Leg, add **\$85.70** list

4 Lock Option:

L Locking, add **\$42.85** list

N Non-Locking

2) Case laminate color.

3) Case laminate edgeband color.

4) Bottom, inset back and fixed shelf trim color.

5) Pull, leg and spacer trim color.

6) Drawer front steel color.

Laminate or Wood Drawer Front

1) Product number, including:

1 Laminate or Wood Drawer Front Option:

L Laminate

W Wood

2 Pull Option: (side bar)

3 Leg Option:

F Straight Leg

P Chamfer Leg, add **\$85.70** list

4 Lock Option:

L Locking, add **\$42.85** list

N Non-Locking

2) Case laminate color.

3) Case laminate edgeband color.

4) Bottom, inset back and fixed shelf trim color.

5) Pull, leg and spacer trim color.

6) Drawer front laminate or wood color.

7) Laminate drawer front edgeband color.

Note: Upcharge for mixed grade fabric or trim surfaces, refer to the electronic design and specification tools for pricing.

Base Unit — Drawer Combinations — Double

Description	Finished Height*	Actual Width	Nominal Width	Pull	Number	Case Laminate A				Wood Door Group A	Wood Door Group B					
						Steel Door Trim A	Steel Door Trim B	Laminate Door A	Laminate Door B							
Double 1H																
Open — Left Lateral File	17"(432mm)	47 7/8"(1216mm)	48"(1219mm)	1,J	QBDF-1748-ZAN	■	■	■	■	\$1396.84	\$1412.90	\$1542.52	\$1598.21	\$1807.10	\$1871.39	
					2,3	QBDF-1748-ZAN	■	■	■	■	1423.62	1439.68	1569.30	1624.99	1833.88	1898.17
					7,8,9	QBDF-1748-ZAN	■	■	■	■	1428.98	1445.04	1574.66	1630.35	1839.24	1903.53
					K	QBDF-1748-ZAN	K	■	■	■	N/A	N/A	1606.79	1662.48	1871.37	1935.66
	Q	QBDF-1748-ZAN	Q	■	■	■	N/A	N/A	1638.93	1694.62	1903.51	1967.80				
	59 7/8"(1521mm)	60"(1524mm)	1,J	QBDF-1760-ZAN	■	■	■	■	\$1546.80	\$1567.14	\$1711.76	\$1773.87	\$2014.90	\$2089.91		
			2,3	QBDF-1760-ZAN	■	■	■	■	1573.58	1593.92	1738.54	1800.65	2041.68	2116.69		
			7,8,9	QBDF-1760-ZAN	■	■	■	■	1578.94	1599.28	1743.90	1806.01	2047.04	2122.05		
			K	QBDF-1760-ZAN	K	■	■	■	N/A	N/A	1776.03	1838.14	2079.17	2154.18		
	Q	QBDF-1760-ZAN	Q	■	■	■	N/A	N/A	1808.17	1870.28	2111.31	2186.32				
	71 7/8"(1826mm)	72"(1829mm)	1,J	QBDF-1772-ZAN	■	■	■	■	\$1696.76	\$1721.38	\$1881.00	\$1949.53	\$2222.70	\$2308.43		
			2,3	QBDF-1772-ZAN	■	■	■	■	1723.54	1748.16	1907.78	1976.31	2249.48	2335.21		
			7,8,9	QBDF-1772-ZAN	■	■	■	■	1728.90	1753.52	1913.14	1981.67	2254.84	2340.57		
			K	QBDF-1772-ZAN	K	■	■	■	N/A	N/A	1945.27	2013.80	2286.97	2372.70		
	Q	QBDF-1772-ZAN	Q	■	■	■	N/A	N/A	1977.41	2045.94	2319.11	2404.84				
	Lateral File Open — Right	17"(432mm)	47 7/8"(1216mm)	48"(1219mm)	1,J	QBDF-1748-AZN	■	■	■	■	\$1396.84	\$1412.90	\$1542.52	\$1598.21	\$1807.10	\$1871.39
2,3						QBDF-1748-AZN	■	■	■	■	1423.62	1439.68	1569.30	1624.99	1833.88	1898.17
7,8,9						QBDF-1748-AZN	■	■	■	■	1428.98	1445.04	1574.66	1630.35	1839.24	1903.53
K						QBDF-1748-AZN	K	■	■	■	N/A	N/A	1606.79	1662.48	1871.37	1935.66
Q		QBDF-1748-AZN	Q	■	■	■	N/A	N/A	1638.93	1694.62	1903.51	1967.80				
59 7/8"(1521mm)		60"(1524mm)	1,J	QBDF-1760-AZN	■	■	■	■	\$1546.80	\$1567.14	\$1711.76	\$1773.87	\$2014.90	\$2089.91		
			2,3	QBDF-1760-AZN	■	■	■	■	1573.58	1593.92	1738.54	1800.65	2041.68	2116.69		
			7,8,9	QBDF-1760-AZN	■	■	■	■	1578.94	1599.28	1743.90	1806.01	2047.04	2122.05		
			K	QBDF-1760-AZN	K	■	■	■	N/A	N/A	1776.03	1838.14	2079.17	2154.18		
Q		QBDF-1760-AZN	Q	■	■	■	N/A	N/A	1808.17	1870.28	2111.31	2186.32				
71 7/8"(1826mm)		72"(1829mm)	1,J	QBDF-1772-AZN	■	■	■	■	\$1696.76	\$1721.38	\$1881.00	\$1949.53	\$2222.70	\$2308.43		
			2,3	QBDF-1772-AZN	■	■	■	■	1723.54	1748.16	1907.78	1976.31	2249.48	2335.21		
			7,8,9	QBDF-1772-AZN	■	■	■	■	1728.90	1753.52	1913.14	1981.67	2254.84	2340.57		
			K	QBDF-1772-AZN	K	■	■	■	N/A	N/A	1945.27	2013.80	2286.97	2372.70		
Q		QBDF-1772-AZN	Q	■	■	■	N/A	N/A	1977.41	2045.94	2319.11	2404.84				
Double 1.5H																
Open - Left Box Drawer/ Lateral File	23"(584mm)	47 7/8"(1216mm)	48"(1219mm)	1,J	QBDF-2348-ZBN	■	■	■	■	\$1764.27	\$1784.61	\$1920.66	\$1976.35	\$2206.67	\$2270.96	
					2,3	QBDF-2348-ZBN	■	■	■	■	1817.83	1838.17	1974.22	2029.91	2260.23	2324.52
					7,8,9	QBDF-2348-ZBN	■	■	■	■	1828.55	1848.89	1984.94	2040.63	2270.95	2335.24
					K	QBDF-2348-ZBN	K	■	■	■	N/A	N/A	2049.20	2104.89	2335.21	2399.50
	Q	QBDF-2348-ZBN	Q	■	■	■	N/A	N/A	2113.48	2169.17	2427.34	2491.63				
	59 7/8"(1521mm)	60"(1524mm)	1,J	QBDF-2360-ZBN	■	■	■	■	\$1914.23	\$1938.85	\$2089.90	\$2152.01	\$2414.47	\$2489.48		
			2,3	QBDF-2360-ZBN	■	■	■	■	1967.79	1992.41	2143.46	2205.57	2468.03	2543.04		
			7,8,9	QBDF-2360-ZBN	■	■	■	■	1978.51	2003.13	2154.18	2216.29	2478.75	2553.76		
			K	QBDF-2360-ZBN	K	■	■	■	N/A	N/A	2218.44	2280.55	2543.01	2618.02		
	Q	QBDF-2360-ZBN	Q	■	■	■	N/A	N/A	2282.72	2344.83	2635.14	2710.15				
	71 7/8"(1826mm)	72"(1829mm)	1,J	QBDF-2372-ZBN	■	■	■	■	\$2064.19	\$2093.09	\$2259.14	\$2327.67	\$2622.27	\$2708.00		
			2,3	QBDF-2372-ZBN	■	■	■	■	2117.75	2146.65	2312.70	2381.23	2675.83	2761.56		
			7,8,9	QBDF-2372-ZBN	■	■	■	■	2128.47	2157.37	2323.42	2391.95	2686.55	2772.28		
			K	QBDF-2372-ZBN	K	■	■	■	N/A	N/A	2387.68	2456.21	2750.81	2836.54		
	Q	QBDF-2372-ZBN	Q	■	■	■	N/A	N/A	2451.96	2520.49	2842.94	2928.67				
	Box Drawer/ Lateral File Open — Right	47 7/8"(1216mm)	48"(1219mm)	1,J	QBDF-2348-BZN	■	■	■	■	\$1764.27	\$1784.61	\$1920.66	\$1976.35	\$2206.67	\$2270.96	
2,3					QBDF-2348-BZN	■	■	■	■	1817.83	1838.17	1974.22	2029.91	2260.23	2324.52	
7,8,9					QBDF-2348-BZN	■	■	■	■	1828.55	1848.89	1984.94	2040.63	2270.95	2335.24	
K					QBDF-2348-BZN	K	■	■	■	N/A	N/A	2049.20	2104.89	2335.21	2399.50	
Q		QBDF-2348-BZN	Q	■	■	■	N/A	N/A	2113.48	2169.17	2427.34	2491.63				
59 7/8"(1521mm)		60"(1524mm)	1,J	QBDF-2360-BZN	■	■	■	■	\$1914.23	\$1938.85	\$2089.90	\$2152.01	\$2414.47	\$2489.48		
			2,3	QBDF-2360-BZN	■	■	■	■	1967.79	1992.41	2143.46	2205.57	2468.03	2543.04		
			7,8,9	QBDF-2360-BZN	■	■	■	■	1978.51	2003.13	2154.18	2216.29	2478.75	2553.76		
			K	QBDF-2360-BZN	K	■	■	■	N/A	N/A	2218.44	2280.55	2543.01	2618.02		
Q		QBDF-2360-BZN	Q	■	■	■	N/A	N/A	2282.72	2344.83	2635.14	2710.15				
71 7/8"(1826mm)		72"(1829mm)	1,J	QBDF-2372-BZN	■	■	■	■	\$2064.19	\$2093.09	\$2259.14	\$2327.67	\$2622.27	\$2708.00		
			2,3	QBDF-2372-BZN	■	■	■	■	2117.75	2146.65	2312.70	2381.23	2675.83	2761.56		
			7,8,9	QBDF-2372-BZN	■	■	■	■	2128.47	2157.37	2323.42	2391.95	2686.55	2772.28		
			K	QBDF-2372-BZN	K	■	■	■	N/A	N/A	2387.68	2456.21	2750.81	2836.54		
Q		QBDF-2372-BZN	Q	■	■	■	N/A	N/A	2451.96	2520.49	2842.94	2928.67				

*Finished Height includes worksurface top, spacer, base unit and legs

Base Unit — Drawer Combinations — Double

Description	Finished Height*	Actual Width	Nominal Width	Pull	Number	Case Laminate A				Wood Door					
						Steel Door Trim A	Trim B	Laminate Door A	Door B	Group A	Group B				
Double 2H															
Open — Left Lateral File/ Lateral File	29"(737mm)	47 7/8"(1216mm)	48"(1219mm)	1, J	QBDF-2948-ZEN	■	■	■	■	\$1951.73	\$1976.36	\$2118.83	\$2174.52	\$2426.26	\$2490.55
				2,3	QBDF-2948-ZEN	■	■	■	■	2005.29	2029.92	2172.39	2228.08	2479.82	2544.11
				7,8,9	QBDF-2948-ZEN	■	■	■	■	2016.01	2040.64	2183.11	2238.80	2490.54	2554.83
				K	QBDF-2948-ZEN	■	K	■	■	N/A	N/A	2247.37	2303.06	2554.80	2619.09
				Q	QBDF-2948-ZEN	■	Q	■	■	N/A	N/A	2311.65	2367.34	2619.08	2683.37
	59 7/8"(1521mm)	60"(1524mm)		1, J	QBDF-2960-ZEN	■	■	■	■	\$2101.69	\$2130.60	\$2288.07	\$2350.18	\$2634.06	\$2709.07
				2,3	QBDF-2960-ZEN	■	■	■	■	2155.25	2184.16	2341.63	2403.74	2687.62	2762.63
				7,8,9	QBDF-2960-ZEN	■	■	■	■	2165.97	2194.88	2352.35	2414.46	2698.34	2773.35
				K	QBDF-2960-ZEN	■	K	■	■	N/A	N/A	2416.61	2478.72	2762.60	2837.61
				Q	QBDF-2960-ZEN	■	Q	■	■	N/A	N/A	2480.89	2543.00	2826.88	2901.89
	71 7/8"(1826mm)	72"(1829mm)		1, J	QBDF-2972-ZEN	■	■	■	■	\$2251.65	\$2284.84	\$2457.31	\$2525.84	\$2841.86	\$2927.59
				2,3	QBDF-2972-ZEN	■	■	■	■	2305.21	2338.40	2510.87	2579.40	2895.42	2981.15
				7,8,9	QBDF-2972-ZEN	■	■	■	■	2315.93	2349.12	2521.59	2590.12	2906.14	2991.87
				K	QBDF-2972-ZEN	■	K	■	■	N/A	N/A	2585.85	2654.38	2970.40	3056.13
				Q	QBDF-2972-ZEN	■	Q	■	■	N/A	N/A	2650.13	2718.66	3034.68	3120.41
Lateral File/ Lateral File Open — Right	29"(737mm)	47 7/8"(1216mm)	48"(1219mm)	1, J	QBDF-2948-EZN	■	■	■	■	\$1951.73	\$1976.36	\$2118.83	\$2174.52	\$2426.26	\$2490.55
				2,3	QBDF-2948-EZN	■	■	■	■	2005.29	2029.92	2172.39	2228.08	2479.82	2544.11
				7,8,9	QBDF-2948-EZN	■	■	■	■	2016.01	2040.64	2183.11	2238.80	2490.54	2554.83
				K	QBDF-2948-EZN	■	K	■	■	N/A	N/A	2247.37	2303.06	2554.80	2619.09
				Q	QBDF-2948-EZN	■	Q	■	■	N/A	N/A	2311.65	2367.34	2619.08	2683.37
	59 7/8"(1521mm)	60"(1524mm)		1, J	QBDF-2960-EZN	■	■	■	■	\$2101.69	\$2130.60	\$2288.07	\$2350.18	\$2634.06	\$2709.07
				2,3	QBDF-2960-EZN	■	■	■	■	2155.25	2184.16	2341.63	2403.74	2687.62	2762.63
				7,8,9	QBDF-2960-EZN	■	■	■	■	2165.97	2194.88	2352.35	2414.46	2698.34	2773.35
				K	QBDF-2960-EZN	■	K	■	■	N/A	N/A	2416.61	2478.72	2762.60	2837.61
				Q	QBDF-2960-EZN	■	Q	■	■	N/A	N/A	2480.89	2543.00	2826.88	2901.89
	71 7/8"(1826mm)	72"(1829mm)		1, J	QBDF-2972-EZN	■	■	■	■	\$2251.65	\$2284.84	\$2457.31	\$2525.84	\$2841.86	\$2927.59
				2,3	QBDF-2972-EZN	■	■	■	■	2305.21	2338.40	2510.87	2579.40	2895.42	2981.15
				7,8,9	QBDF-2972-EZN	■	■	■	■	2315.93	2349.12	2521.59	2590.12	2906.14	2991.87
				K	QBDF-2972-EZN	■	K	■	■	N/A	N/A	2585.85	2654.38	2970.40	3056.13
				Q	QBDF-2972-EZN	■	Q	■	■	N/A	N/A	2650.13	2718.66	3034.68	3120.41

*Finished Height includes worksurface top, spacer, base unit and legs

Base Unit — Drawer Combinations — Double

Description	Finished Height*	Actual Width	Nominal Width	Pull	Number	Case Laminate B				Wood Door						
						Steel Door Trim A	Steel Door Trim B	Laminate Door A	Laminate Door B	Group A	Group B					
Double 1H																
Open — Left Lateral File	17"(432mm)	47 7/8"(1216mm)	48"(1219mm)	1,J	QBDF-1748-ZAN	■	■	■	■	\$1447.18	\$1463.24	\$1592.86	\$1648.55	\$1857.44	\$1921.73	
					2,3	QBDF-1748-ZAN	■	■	■	■	1473.96	1490.02	1619.64	1675.33	1884.22	1948.51
					7,8,9	QBDF-1748-ZAN	■	■	■	■	1479.32	1495.38	1625.00	1680.69	1889.58	1953.87
					K	QBDF-1748-ZAN	K	■	■	■	N/A	N/A	1657.13	1712.82	1921.71	1986.00
	Q	QBDF-1748-ZAN	Q	■	■	■	N/A	N/A	1689.27	1744.96	1953.85	2018.14				
	59 7/8"(1521mm)	60"(1524mm)	1,J	QBDF-1760-ZAN	■	■	■	■	\$1601.42	\$1621.76	\$1766.38	\$1828.49	\$2069.52	\$2144.53		
			2,3	QBDF-1760-ZAN	■	■	■	■	1628.20	1648.54	1793.16	1855.27	2096.30	2171.31		
			7,8,9	QBDF-1760-ZAN	■	■	■	■	1633.56	1653.90	1798.52	1860.63	2101.66	2176.67		
			K	QBDF-1760-ZAN	K	■	■	■	N/A	N/A	1830.65	1892.76	2133.79	2208.80		
	Q	QBDF-1760-ZAN	Q	■	■	■	N/A	N/A	1862.79	1924.90	2165.93	2240.94				
	71 7/8"(1826mm)	72"(1829mm)	1,J	QBDF-1772-ZAN	■	■	■	■	\$1755.66	\$1780.28	\$1939.90	\$2008.43	\$2281.60	\$2367.33		
			2,3	QBDF-1772-ZAN	■	■	■	■	1782.44	1807.06	1966.68	2035.21	2308.38	2394.11		
			7,8,9	QBDF-1772-ZAN	■	■	■	■	1787.80	1812.42	1972.04	2040.57	2313.74	2399.47		
			K	QBDF-1772-ZAN	K	■	■	■	N/A	N/A	2004.17	2072.70	2345.87	2431.60		
	Q	QBDF-1772-ZAN	Q	■	■	■	N/A	N/A	2036.31	2104.84	2378.01	2463.74				
	Lateral File Open — Right	17"(432mm)	47 7/8"(1216mm)	48"(1219mm)	1,J	QBDF-1748-AZN	■	■	■	■	\$1447.18	\$1463.24	\$1592.86	\$1648.55	\$1857.44	\$1921.73
2,3						QBDF-1748-AZN	■	■	■	■	1473.96	1490.02	1619.64	1675.33	1884.22	1948.51
7,8,9						QBDF-1748-AZN	■	■	■	■	1479.32	1495.38	1625.00	1680.69	1889.58	1953.87
K						QBDF-1748-AZN	K	■	■	■	N/A	N/A	1657.13	1712.82	1921.71	1986.00
Q		QBDF-1748-AZN	Q	■	■	■	N/A	N/A	1689.27	1744.96	1953.85	2018.14				
59 7/8"(1521mm)		60"(1524mm)	1,J	QBDF-1760-AZN	■	■	■	■	\$1601.42	\$1621.76	\$1766.38	\$1828.49	\$2069.52	\$2144.53		
			2,3	QBDF-1760-AZN	■	■	■	■	1628.20	1648.54	1793.16	1855.27	2096.30	2171.31		
			7,8,9	QBDF-1760-AZN	■	■	■	■	1633.56	1653.90	1798.52	1860.63	2101.66	2176.67		
			K	QBDF-1760-AZN	K	■	■	■	N/A	N/A	1830.65	1892.76	2133.79	2208.80		
Q		QBDF-1760-AZN	Q	■	■	■	N/A	N/A	1862.79	1924.90	2165.93	2240.94				
71 7/8"(1826mm)		72"(1829mm)	1,J	QBDF-1772-AZN	■	■	■	■	\$1755.66	\$1780.28	\$1939.90	\$2008.43	\$2281.60	\$2367.33		
			2,3	QBDF-1772-AZN	■	■	■	■	1782.44	1807.06	1966.68	2035.21	2308.38	2394.11		
			7,8,9	QBDF-1772-AZN	■	■	■	■	1787.80	1812.42	1972.04	2040.57	2313.74	2399.47		
			K	QBDF-1772-AZN	K	■	■	■	N/A	N/A	2004.17	2072.70	2345.87	2431.60		
Q		QBDF-1772-AZN	Q	■	■	■	N/A	N/A	2036.31	2104.84	2378.01	2463.74				
Double 1.5H																
Open - Left Box Drawer/ Lateral File	23"(584mm)	47 7/8"(1216mm)	48"(1219mm)	1,J	QBDF-2348-ZBN	■	■	■	■	\$1821.03	\$1841.37	\$1977.42	\$2033.11	\$2263.43	\$2327.72	
					2,3	QBDF-2348-ZBN	■	■	■	■	1874.59	1894.93	2030.98	2086.67	2316.99	2381.28
					7,8,9	QBDF-2348-ZBN	■	■	■	■	1885.31	1905.65	2041.70	2097.39	2327.71	2392.00
					K	QBDF-2348-ZBN	K	■	■	■	N/A	N/A	2105.96	2161.65	2391.97	2456.26
	Q	QBDF-2348-ZBN	Q	■	■	■	N/A	N/A	2170.24	2225.93	2484.10	2548.39				
	59 7/8"(1521mm)	60"(1524mm)	1,J	QBDF-2360-ZBN	■	■	■	■	\$1975.27	\$1999.89	\$2150.94	\$2213.05	\$2475.51	\$2550.52		
			2,3	QBDF-2360-ZBN	■	■	■	■	2028.83	2053.45	2204.50	2266.61	2529.07	2604.08		
			7,8,9	QBDF-2360-ZBN	■	■	■	■	2039.55	2064.17	2215.22	2277.33	2539.79	2614.80		
			K	QBDF-2360-ZBN	K	■	■	■	N/A	N/A	2279.48	2341.59	2604.05	2679.06		
	Q	QBDF-2360-ZBN	Q	■	■	■	N/A	N/A	2343.76	2405.87	2696.18	2771.19				
	71 7/8"(1826mm)	72"(1829mm)	1,J	QBDF-2372-ZBN	■	■	■	■	\$2129.51	\$2158.41	\$2324.46	\$2392.99	\$2687.59	\$2773.32		
			2,3	QBDF-2372-ZBN	■	■	■	■	2183.07	2211.97	2378.02	2446.55	2741.15	2826.88		
			7,8,9	QBDF-2372-ZBN	■	■	■	■	2193.79	2222.69	2388.74	2457.27	2751.87	2837.60		
			K	QBDF-2372-ZBN	K	■	■	■	N/A	N/A	2453.00	2521.53	2816.13	2901.86		
	Q	QBDF-2372-ZBN	Q	■	■	■	N/A	N/A	2517.28	2585.81	2908.26	2993.99				
	Box Drawer/ Lateral File Open — Right	47 7/8"(1216mm)	48"(1219mm)	1,J	QBDF-2348-BZN	■	■	■	■	\$1821.03	\$1841.37	\$1977.42	\$2033.11	\$2263.43	\$2327.72	
2,3					QBDF-2348-BZN	■	■	■	■	1874.59	1894.93	2030.98	2086.67	2316.99	2381.28	
7,8,9					QBDF-2348-BZN	■	■	■	■	1885.31	1905.65	2041.70	2097.39	2327.71	2392.00	
K					QBDF-2348-BZN	K	■	■	■	N/A	N/A	2105.96	2161.65	2391.97	2456.26	
Q		QBDF-2348-BZN	Q	■	■	■	N/A	N/A	2170.24	2225.93	2484.10	2548.39				
59 7/8"(1521mm)		60"(1524mm)	1,J	QBDF-2360-BZN	■	■	■	■	\$1975.27	\$1999.89	\$2150.94	\$2213.05	\$2475.51	\$2550.52		
			2,3	QBDF-2360-BZN	■	■	■	■	2028.83	2053.45	2204.50	2266.61	2529.07	2604.08		
			7,8,9	QBDF-2360-BZN	■	■	■	■	2039.55	2064.17	2215.22	2277.33	2539.79	2614.80		
			K	QBDF-2360-BZN	K	■	■	■	N/A	N/A	2279.48	2341.59	2604.05	2679.06		
Q		QBDF-2360-BZN	Q	■	■	■	N/A	N/A	2343.76	2405.87	2696.18	2771.19				
71 7/8"(1826mm)		72"(1829mm)	1,J	QBDF-2372-BZN	■	■	■	■	\$2129.51	\$2158.41	\$2324.46	\$2392.99	\$2687.59	\$2773.32		
			2,3	QBDF-2372-BZN	■	■	■	■	2183.07	2211.97	2378.02	2446.55	2741.15	2826.88		
			7,8,9	QBDF-2372-BZN	■	■	■	■	2193.79	2222.69	2388.74	2457.27	2751.87	2837.60		
			K	QBDF-2372-BZN	K	■	■	■	N/A	N/A	2453.00	2521.53	2816.13	2901.86		
Q		QBDF-2372-BZN	Q	■	■	■	N/A	N/A	2517.28	2585.81	2908.26	2993.99				

*Finished Height includes worksurface top, spacer, base unit and legs

Base Unit — Drawer Combinations — Double

Description	Finished Height*	Actual Width	Nominal Width	Pull	Number	Case Laminate B				Wood Door					
						Steel Door Trim A	Trim B	Laminate Door A	Door B	Group A	Group B				
Double 2H															
Open — Left Lateral File/ Lateral File	29"(737mm)	47 7/8"(1216mm)	48"(1219mm)	1, J	QBDF-2948-ZEN	■	■	■	■	\$2014.92	\$2039.55	\$2182.02	\$2237.71	\$2489.45	\$2553.74
				2,3	QBDF-2948-ZEN	■	■	■	■	2068.48	2093.11	2235.58	2291.27	2543.01	2607.30
				7,8,9	QBDF-2948-ZEN	■	■	■	■	2079.20	2103.83	2246.30	2301.99	2553.73	2618.02
				K	QBDF-2948-ZEN	■	K	■	■	N/A	N/A	2310.56	2366.25	2617.99	2682.28
				Q	QBDF-2948-ZEN	■	Q	■	■	N/A	N/A	2374.84	2430.53	2682.27	2746.56
	59 7/8"(1521mm)	60"(1524mm)		1, J	QBDF-2960-ZEN	■	■	■	■	\$2169.16	\$2198.07	\$2355.54	\$2417.65	\$2701.53	\$2776.54
				2,3	QBDF-2960-ZEN	■	■	■	■	2222.72	2251.63	2409.10	2471.21	2755.09	2830.10
				7,8,9	QBDF-2960-ZEN	■	■	■	■	2233.44	2262.35	2419.82	2481.93	2765.81	2840.82
				K	QBDF-2960-ZEN	■	K	■	■	N/A	N/A	2484.08	2546.19	2830.07	2905.08
				Q	QBDF-2960-ZEN	■	Q	■	■	N/A	N/A	2548.36	2610.47	2894.35	2969.36
	71 7/8"(1826mm)	72"(1829mm)		1, J	QBDF-2972-ZEN	■	■	■	■	\$2323.40	\$2356.59	\$2529.06	\$2597.59	\$2913.61	\$2999.34
				2,3	QBDF-2972-ZEN	■	■	■	■	2376.96	2410.15	2582.62	2651.15	2967.17	3052.90
				7,8,9	QBDF-2972-ZEN	■	■	■	■	2387.68	2420.87	2593.34	2661.87	2977.89	3063.62
				K	QBDF-2972-ZEN	■	K	■	■	N/A	N/A	2657.60	2726.13	3042.15	3127.88
				Q	QBDF-2972-ZEN	■	Q	■	■	N/A	N/A	2721.88	2790.41	3106.43	3192.16
Lateral File/ Lateral File Open — Right	29"(737mm)	47 7/8"(1216mm)	48"(1219mm)	1, J	QBDF-2948-EZN	■	■	■	■	\$2014.92	\$2039.55	\$2182.02	\$2237.71	\$2489.45	\$2553.74
				2,3	QBDF-2948-EZN	■	■	■	■	2068.48	2093.11	2235.58	2291.27	2543.01	2607.30
				7,8,9	QBDF-2948-EZN	■	■	■	■	2079.20	2103.83	2246.30	2301.99	2553.73	2618.02
				K	QBDF-2948-EZN	■	K	■	■	N/A	N/A	2310.56	2366.25	2617.99	2682.28
				Q	QBDF-2948-EZN	■	Q	■	■	N/A	N/A	2374.84	2430.53	2682.27	2746.56
	59 7/8"(1521mm)	60"(1524mm)		1, J	QBDF-2960-EZN	■	■	■	■	\$2169.16	\$2198.07	\$2355.54	\$2417.65	\$2701.53	\$2776.54
				2,3	QBDF-2960-EZN	■	■	■	■	2222.72	2251.63	2409.10	2471.21	2755.09	2830.10
				7,8,9	QBDF-2960-EZN	■	■	■	■	2233.44	2262.35	2419.82	2481.93	2765.81	2840.82
				K	QBDF-2960-EZN	■	K	■	■	N/A	N/A	2484.08	2546.19	2830.07	2905.08
				Q	QBDF-2960-EZN	■	Q	■	■	N/A	N/A	2548.36	2610.47	2894.35	2969.36
	71 7/8"(1826mm)	72"(1829mm)		1, J	QBDF-2972-EZN	■	■	■	■	\$2323.40	\$2356.59	\$2529.06	\$2597.59	\$2913.61	\$2999.34
				2,3	QBDF-2972-EZN	■	■	■	■	2376.96	2410.15	2582.62	2651.15	2967.17	3052.90
				7,8,9	QBDF-2972-EZN	■	■	■	■	2387.68	2420.87	2593.34	2661.87	2977.89	3063.62
				K	QBDF-2972-EZN	■	K	■	■	N/A	N/A	2657.60	2726.13	3042.15	3127.88
				Q	QBDF-2972-EZN	■	Q	■	■	N/A	N/A	2721.88	2790.41	3106.43	3192.16

*Finished Height includes worksurface top, spacer, base unit and legs

Base Unit — Drawer Combinations — Triple

Drawer Combinations — Triple

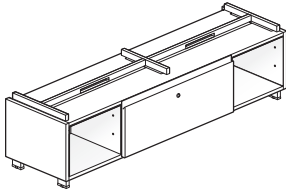

QBTF-XXXX-ZAZ

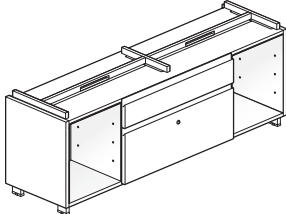

QBTF-XXXX-ZBZ

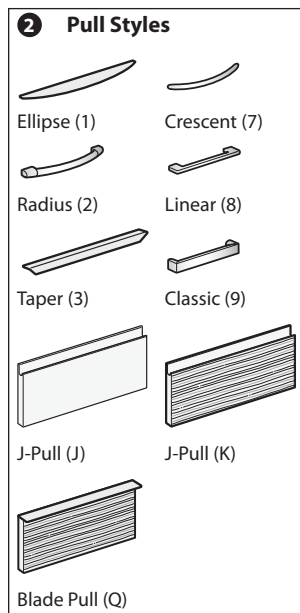

Features

- Open Storage with a drawer include:
 - Laminate end panel and inner top.
 - Painted Steel inner back and bottom.
 - Painted Steel spacer.
- Leg Options:
 - Straight Leg (F)
 - Chamfer Leg (P)
- Glide adjustment range:
 - Straight Leg: 1.5”(38mm)
 - Chamfer Leg: 1.25”(32mm)
- Spacer:
 - 1.18”(30mm) high
 - End pieces come in specified color; center spacer section black only.
- Drawer interior is black.
- Lateral file includes side-to-side filing bar.
- Full extension drawers.
- Drawer front options include painted steel, laminate or wood.
- Ellipse pull available in non-metallic color only. (see finish page for pull color)
- Radius pull available in metallic colors only. (see finish page for pull color)
- J-Pull (J) matches painted steel fronts.
- J-Pull (K) or Blade Pull (Q) available on laminate or wood fronts only. Must specify color.
- Lock Options:
 - Locking (chrome only) and non-locking available.
 - One lock accommodates all drawers.
- Shelves are separately specified; not included with unit.
- Case ships assembled. Legs require field installation.

Specification Tips

- Designed to be used with Haworth's Integrated Palette, UniGroup Too, PREMISE, Reside Desking and/or Belong Work Tools.
- All base units with drawers must be attached. Refer to Specification Guide for planning information.
- Separately specified storage tops are required and can match the width of a single base unit or span two or more adjacent base units side by side.
- To route and access power in storage, order separately specified Belong power components.
- 1.5H and 2H storage can be used to support Reside desking or Adaptable worksurfaces in a perpendicular configuration with separately specified brackets. Refer to Specification Guide for planning information.
- Beside base storage unit with top, spacer, base unit and legs finished heights:
 - 1H = 17”(432mm)
 - 1.5H = 23”(584mm)
 - 2H = 29”(737mm)
- Separately specified if applicable:
 - Belong Power and communication cabling, tools, screens and tool rails.
 - Storage-to-Panel Bracket
 - Storage Attachment Bracket
 - Ganging Bracket
 - Storage Top (required)
 - Filler Panel
 - Top Filler Track
 - Finished Back (recommended when back is exposed)
 - Adjustable Shelf (not included with unit)
 - Stack-On Hutch
 - Front-to-Back Filing Bars
- Refer to Specification Guide for planning information and actual dimensions.

Notes: 2H storage base units are not designed to fit under Reside benching or return worksurfaces. Reside Desking or Adaptable worksurfaces can be attached to the front or back of a 2H Beside storage unit with separately specified flush mount plates.

Separately specified Belong base unit power components available for 30”-72”(372mm-1829mm) widths only.

Storage shelves are unique to the specific base unit configuration. Refer to shelf price list pages for appropriate shelf.

1H units cannot accept binders.

To Order, Specify:

Steel Drawer Front

- 1) Product number, including:

1 Steel Drawer Front Option:

S Steel

2 Pull Option: (see side bar)

3 Leg Option:

F Straight Leg

P Chamfer Leg, add **\$85.70** list

4 Lock Option:

L Locking, add **\$42.85** list

N Non-Locking

- 2) Case laminate color.

- 3) Case laminate edgeband color.

- 4) Bottom, inset back and fixed shelf trim color.

- 5) Pull, leg and spacer trim color.

- 6) Drawer front steel color.

Laminate or Wood Drawer Front

- 1) Product number, including:

1 Laminate or Wood Drawer Front Option:

L Laminate

W Wood

2 Pull Option: (see side bar)

3 Leg Option

F Straight Leg

P Chamfer Leg, add **\$85.70** list

4 Lock Option:

L Locking, add **\$42.85** list

N Non-Locking

- 2) Case laminate color.

- 3) Case laminate edgeband color.

- 4) Bottom, inset back and fixed shelf trim color.

- 5) Pull, leg and spacer trim color.

- 6) Drawer front laminate or wood color.

- 7) Laminate drawer front edgeband color.

Note: Upcharge for mixed grade fabric or trim surfaces, refer to the electronic design and specification tools for pricing.

Base Unit — Drawer Combinations — Triple

Description	Finished Height*	Actual Width	Nominal Width	Pull	Number	Case Laminate A				Wood Door					
						Steel Door Trim A	Trim B	Laminate Door A	Door B	Group A	Group B				
Triple — 1H															
Open Storage/ Lateral File/ Open Storage	17"(432mm)	47 7/8"(1216mm)	48"(1219mm)	1, J	QBTF-1748-ZAZ	■	■	■	■	\$1875.67	\$1891.73	\$2134.90	\$2242.02	\$2568.74	\$2654.43
				2,3	QBTF-1748-ZAZ	■	■	■	■	1902.45	1918.51	2161.68	2268.80	2595.52	2681.21
				7,8,9	QBTF-1748-ZAZ	■	■	■	■	1907.81	1923.87	2167.04	2274.16	2600.88	2686.57
				K	QBTF-1748-ZAZ	■	K	■	■	N/A	N/A	2199.17	2306.29	2633.01	2718.70
				Q	QBTF-1748-ZAZ	■	Q	■	■	N/A	N/A	2231.31	2338.43	2665.15	2750.84
	59 7/8"(1521mm)	60"(1524mm)		1, J	QBTF-1760-ZAZ	■	■	■	■	\$1976.37	\$1996.71	\$2251.67	\$2362.00	\$2712.29	\$2805.48
				2,3	QBTF-1760-ZAZ	■	■	■	■	2003.15	2023.49	2278.45	2388.78	2739.07	2832.26
				7,8,9	QBTF-1760-ZAZ	■	■	■	■	2008.51	2028.85	2283.81	2394.14	2744.43	2837.62
				K	QBTF-1760-ZAZ	■	K	■	■	N/A	N/A	2315.94	2426.27	2776.56	2869.75
				Q	QBTF-1760-ZAZ	■	Q	■	■	N/A	N/A	2348.08	2458.41	2808.70	2901.89
	71 7/8"(1826mm)	72"(1829mm)		1, J	QBTF-1772-ZAZ	■	■	■	■	\$2077.07	\$2101.69	\$2368.44	\$2481.98	\$2855.84	\$2956.53
				2,3	QBTF-1772-ZAZ	■	■	■	■	2103.85	2128.47	2395.22	2508.76	2882.62	2983.31
				7,8,9	QBTF-1772-ZAZ	■	■	■	■	2109.21	2133.83	2400.58	2514.12	2887.98	2988.67
				K	QBTF-1772-ZAZ	■	K	■	■	N/A	N/A	2432.71	2546.25	2920.11	3020.80
				Q	QBTF-1772-ZAZ	■	Q	■	■	N/A	N/A	2464.85	2578.39	2952.25	3052.94
Triple — 1.5H															
Open Storage/ Box Drawer and Lateral File/ Open Storage	23"(584mm)	47 7/8"(1216mm)	48"(1219mm)	1, J	QBTF-2348-ZBZ	■	■	■	■	\$2036.35	\$2056.69	\$2295.58	\$2402.70	\$2729.42	\$2815.11
				2,3	QBTF-2348-ZBZ	■	■	■	■	2089.91	2110.25	2349.14	2456.26	2782.98	2868.67
				7,8,9	QBTF-2348-ZBZ	■	■	■	■	2100.63	2120.97	2359.86	2466.98	2793.70	2879.39
				K	QBTF-2348-ZBZ	■	K	■	■	N/A	N/A	2424.12	2531.24	2857.96	2943.65
				Q	QBTF-2348-ZBZ	■	Q	■	■	N/A	N/A	2488.40	2595.52	2922.24	3007.93
	59 7/8"(1521mm)	60"(1524mm)		1, J	QBTF-2360-ZBZ	■	■	■	■	\$2137.05	\$2161.67	\$2412.35	\$2522.68	\$2872.97	\$2966.16
				2,3	QBTF-2360-ZBZ	■	■	■	■	2190.61	2215.23	2465.91	2576.24	2926.53	3019.72
				7,8,9	QBTF-2360-ZBZ	■	■	■	■	2201.33	2225.95	2476.63	2586.96	2937.25	3030.44
				K	QBTF-2360-ZBZ	■	K	■	■	N/A	N/A	2540.89	2651.22	3001.51	3094.70
				Q	QBTF-2360-ZBZ	■	Q	■	■	N/A	N/A	2605.17	2715.50	3065.79	3158.98
	71 7/8"(1826mm)	72"(1829mm)		1, J	QBTF-2372-ZBZ	■	■	■	■	\$2237.75	\$2266.65	\$2529.12	\$2642.66	\$3016.52	\$3117.21
				2,3	QBTF-2372-ZBZ	■	■	■	■	2291.31	2320.21	2582.68	2696.22	3070.08	3170.77
				7,8,9	QBTF-2372-ZBZ	■	■	■	■	2302.03	2330.93	2593.40	2706.94	3080.80	3181.49
				K	QBTF-2372-ZBZ	■	K	■	■	N/A	N/A	2657.66	2771.20	3145.06	3245.75
				Q	QBTF-2372-ZBZ	■	Q	■	■	N/A	N/A	2721.94	2835.48	3209.34	3310.03

*Finished Height includes worksurface top, spacer, base unit and legs

Base Unit — Drawer Combinations — Triple

Description	Finished Height*	Actual Width	Nominal Width	Pull	Number	Case Laminate B				Wood Door					
						Steel Door Trim A	Trim B	Laminate Door A	Door B	Group A	Group B				
Triple — 1H															
Open Storage/ Lateral File/ Open Storage	17"(432mm)	47 7/8"(1216mm)	48"(1219mm)	1, J	QBTF-1748-ZAZ	■	■	■	■	\$1926.01	\$1942.07	\$2185.24	\$2292.36	\$2619.08	\$2704.77
				2,3	QBTF-1748-ZAZ	■	■	■	■	1952.79	1968.85	2212.02	2319.14	2645.86	2731.55
				7,8,9	QBTF-1748-ZAZ	■	■	■	■	1958.15	1974.21	2217.38	2324.50	2651.22	2736.91
				K	QBTF-1748-ZAZ	■	K	■	■	N/A	N/A	2249.51	2356.63	2683.35	2769.04
				Q	QBTF-1748-ZAZ	■	Q	■	■	N/A	N/A	2281.65	2388.77	2715.49	2801.18
	59 7/8"(1521mm)	60"(1524mm)		1, J	QBTF-1760-ZAZ	■	■	■	■	\$2030.99	\$2051.33	\$2306.29	\$2416.62	\$2766.91	\$2860.10
				2,3	QBTF-1760-ZAZ	■	■	■	■	2057.77	2078.11	2333.07	2443.40	2793.69	2886.88
				7,8,9	QBTF-1760-ZAZ	■	■	■	■	2063.13	2083.47	2338.43	2448.76	2799.05	2892.24
				K	QBTF-1760-ZAZ	■	K	■	■	N/A	N/A	2370.56	2480.89	2831.18	2924.37
				Q	QBTF-1760-ZAZ	■	Q	■	■	N/A	N/A	2402.70	2513.03	2863.32	2956.51
	71 7/8"(1826mm)	72"(1829mm)		1, J	QBTF-1772-ZAZ	■	■	■	■	\$2135.97	\$2160.59	\$2427.34	\$2540.88	\$2914.74	\$3015.43
				2,3	QBTF-1772-ZAZ	■	■	■	■	2162.75	2187.37	2454.12	2567.66	2941.52	3042.21
				7,8,9	QBTF-1772-ZAZ	■	■	■	■	2168.11	2192.73	2459.48	2573.02	2946.88	3047.57
				K	QBTF-1772-ZAZ	■	K	■	■	N/A	N/A	2491.61	2605.15	2979.01	3079.70
				Q	QBTF-1772-ZAZ	■	Q	■	■	N/A	N/A	2523.75	2637.29	3011.15	3111.84
Triple — 1.5H															
Open Storage/ Box Drawer and Lateral File/ Open Storage	23"(584mm)	47 7/8"(1216mm)	48"(1219mm)	1, J	QBTF-2348-ZBZ	■	■	■	■	\$2093.11	\$2113.45	\$2352.34	\$2459.46	\$2786.18	\$2871.87
				2,3	QBTF-2348-ZBZ	■	■	■	■	2146.67	2167.01	2405.90	2513.02	2839.74	2925.43
				7,8,9	QBTF-2348-ZBZ	■	■	■	■	2157.39	2177.73	2416.62	2523.74	2850.46	2936.15
				K	QBTF-2348-ZBZ	■	K	■	■	N/A	N/A	2480.88	2588.00	2914.72	3000.41
				Q	QBTF-2348-ZBZ	■	Q	■	■	N/A	N/A	2545.16	2652.28	2979.00	3064.69
	59 7/8"(1521mm)	60"(1524mm)		1, J	QBTF-2360-ZBZ	■	■	■	■	\$2198.09	\$2222.71	\$2473.39	\$2583.72	\$2934.01	\$3027.20
				2,3	QBTF-2360-ZBZ	■	■	■	■	2251.65	2276.27	2526.95	2637.28	2987.57	3080.76
				7,8,9	QBTF-2360-ZBZ	■	■	■	■	2262.37	2286.99	2537.67	2648.00	2998.29	3091.48
				K	QBTF-2360-ZBZ	■	K	■	■	N/A	N/A	2601.93	2712.26	3062.55	3155.74
				Q	QBTF-2360-ZBZ	■	Q	■	■	N/A	N/A	2666.21	2776.54	3126.83	3220.02
	71 7/8"(1826mm)	72"(1829mm)		1, J	QBTF-2372-ZBZ	■	■	■	■	\$2303.07	\$2331.97	\$2594.44	\$2707.98	\$3081.84	\$3182.53
				2,3	QBTF-2372-ZBZ	■	■	■	■	2356.63	2385.53	2648.00	2761.54	3135.40	3236.09
				7,8,9	QBTF-2372-ZBZ	■	■	■	■	2367.35	2396.25	2658.72	2772.26	3146.12	3246.81
				K	QBTF-2372-ZBZ	■	K	■	■	N/A	N/A	2722.98	2836.52	3210.38	3311.07
				Q	QBTF-2372-ZBZ	■	Q	■	■	N/A	N/A	2787.26	2900.80	3274.66	3375.35

*Finished Height includes worksurface top, spacer, base unit and legs

Base Unit — Hinged Door

Hinged Door

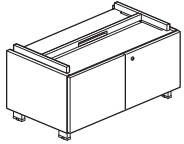

QB5F-XXXX-GNN

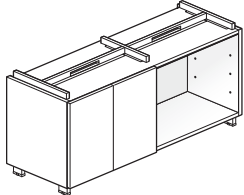

QBDF-XXXX-HZN

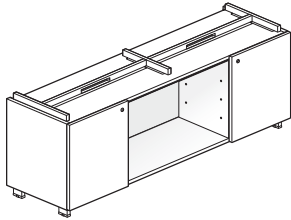

QBTF-XXXX-HZH

2 Pull Styles

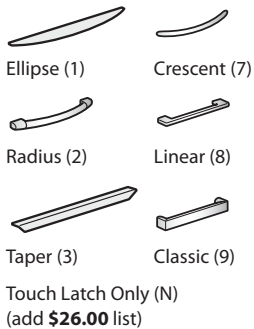

Touch Latch Only (N)
(add **\$26.00** list)

Features

- Hinged Door Single Base Unit include:
 - Laminate case standard with a painted steel inset back and base.
 - Full access hinges that open 100 degrees.
 - If specified right-hand door includes touch latch mechanism (free swing hinge).
 - If specified left-hand door includes full length return flange (self-closing hinge).
 - Leg and drawer options.
 - Spacer
- Ellipse pull available in non-metallic color only. (see finish page for pull color)
- Radius pull available in metallic colors only. (see finish page for pull color)
- Leg Options:
 - Straight Leg (F); requires trim color.
 - Chamfer Leg (P); requires trim color.
- Glide adjustment range:
 - Straight Leg: 1.5”(38mm)
 - Chamfer Leg: 1.25”(32mm)
- Spacer:
 - 1.18”(30mm) high
 - End pieces come in specified color; center spacer section black only.
- Optional door fronts include painted, laminate or wood.
- Lock plugs:
 - Locking (chrome only) and non-locking available.
 - Single and double base units have one lock.
 - Triple base units may have more than one lock.
- Case ships assembled. Legs require field installation.

Specification Tips

- Designed to be used with Haworth’s Integrated Palette, UniGroup Too, PREMISE, Reside Desking and/or Belong Work Tools.
- Ellipse pull is not available on 12”(305mm) wide hinge doors.
- Beside base units 24”-42”(610mm-1067mm) cannot be freestanding. Units must be attached or ganged together. All base units with drawers must be attached. Refer to Specification Guide for planning information.
- Beside base units 48”-72”(1219mm-1829mm) widths can be freestanding.
- Separately specified storage tops are required and can match the width of a single base unit or span two or more adjacent base units side by side.
- To route and access power in storage, order separately specified Belong power components.
- 1.5H and 2H storage can be used to support Reside desking or Adaptable worksurface in a perpendicular configuration with separately specified brackets. Refer to Specification Guide for planning information.
- Beside base storage unit with top, spacer, base unit and legs finished heights:
 - 1H = 17”(432mm)
 - 1.5H = 23”(584mm)
 - 2H = 29”(737mm)
- Separately specified if applicable:
 - Belong Power and communication cabling, tools, screens and tool rails.
 - Storage-to-Panel Bracket
 - Storage Attachment Bracket
 - Ganging Bracket
 - Storage Top (required)
 - Filler Panel
 - Top Filler Track
 - Finished Back (recommended when back is exposed)
 - Adjustable Shelf (not included with unit)
 - Stack-On Hutch
- Refer to Specification Guide for planning information and actual dimensions.

Notes: 2H storage base units are not designed to fit under Reside benching or return worksurfaces. Reside Desking or Adaptable worksurfaces can be attached to the front or back of a 2H Beside storage unit with separately specified flush mount plates. Separately specified Belong base unit power components available for 30”-72”(372mm-1829mm) widths.

Storage shelves are unique to the specific base unit configuration. Refer to shelf price list pages for appropriate shelf.

1H units cannot accept binders.

To Order, Specify:

Steel, Laminate or Wood Door Front

1) Product number, including:

1 Door Front Option:

- S** Steel
- L** Laminate
- W** Wood

2 Pull Option: (see side bar)

3 Leg Option:

- F** Straight Leg
- P** Chamfer Leg, add **\$85.70** list

4 Lock Option:

- L** Locking, add **\$42.85** list
- N** Non-Locking

2) Case laminate color.

3) Case laminate edgeband color.

4) Bottom, inset back and fixed shelf trim color.

5) Pull, leg and spacer trim color.

6) Material front color

7) Material front edgeband color (laminate only).

Note: Upcharge for mixed grade fabric or trim surfaces, refer to the electronic design and specification tools for pricing.

Base Unit — Hinged Door

Description	Finished Height*	Actual Width	Nominal Width	Pull	Number	Case Laminate A				Wood Door		
						Steel Door Trim A	Trim B	Laminate Door A	Door B	Group A	Group B	
Single — 1H												
12"H Hinged Door	17"(432mm)	23 7/8"(606mm)	24"(610mm)	2,3	QBSF-1724-GNN	■ ■ ■ ■	\$ 824.83	\$ 832.33	\$ 931.95	\$ 974.80	\$1119.41	\$1162.26
				7,8,9	QBSF-1724-GNN	■ ■ ■ ■	835.55	843.05	942.67	985.52	1130.13	1172.98
		29 7/8"(759mm)	30"(762mm)	1	QBSF-1730-GNN	■ ■ ■ ■	\$ 810.90	\$ 820.54	\$ 927.66	\$ 973.72	\$1134.40	\$1182.61
				2,3	QBSF-1730-GNN	■ ■ ■ ■	864.46	874.10	981.22	1027.28	1187.96	1236.17
				7,8,9	QBSF-1730-GNN	■ ■ ■ ■	875.18	884.82	991.94	1038.00	1198.68	1246.89
		35 7/8"(911mm)	36"(914mm)	1	QBSF-1736-GNN	■ ■ ■ ■	\$ 850.53	\$ 862.31	\$ 976.93	\$1026.20	\$1202.95	\$1256.52
				2,3	QBSF-1736-GNN	■ ■ ■ ■	904.09	915.87	1030.49	1079.76	1256.51	1310.08
				7,8,9	QBSF-1736-GNN	■ ■ ■ ■	914.81	926.59	1041.21	1090.48	1267.23	1320.80
		41 7/8"(1064mm)	42"(1067mm)	1	QBSF-1742-GNN	■ ■ ■ ■	\$ 890.16	\$ 904.08	\$1026.20	\$1078.68	\$1271.50	\$1330.43
				2,3	QBSF-1742-GNN	■ ■ ■ ■	943.72	957.64	1079.76	1132.24	1325.06	1383.99
				7,8,9	QBSF-1742-GNN	■ ■ ■ ■	954.44	968.36	1090.48	1142.96	1335.78	1394.71
Single — 1.5H												
18"H Hinged Door	23"(584mm)	23 7/8"(606mm)	24"(610mm)	2,3	QBSF-2324-HNN	■ ■ ■ ■	\$ 942.66	\$ 954.44	\$1060.49	\$1103.34	\$1269.38	\$1312.23
				7,8,9	QBSF-2324-HNN	■ ■ ■ ■	953.38	965.16	1071.21	1114.06	1280.10	1322.95
		29 7/8"(759mm)	30"(762mm)	1	QBSF-2330-HNN	■ ■ ■ ■	\$ 937.30	\$ 951.22	\$1064.77	\$1110.83	\$1292.94	\$1341.15
				2,3	QBSF-2330-HNN	■ ■ ■ ■	990.86	1004.78	1118.33	1164.39	1346.50	1394.71
				7,8,9	QBSF-2330-HNN	■ ■ ■ ■	1001.58	1015.50	1129.05	1175.11	1357.22	1405.43
		35 7/8"(911mm)	36"(914mm)	1	QBSF-2336-HNN	■ ■ ■ ■	\$ 985.50	\$1001.56	\$1122.61	\$1171.88	\$1370.06	\$1423.63
				2,3	QBSF-2336-HNN	■ ■ ■ ■	1039.06	1055.12	1176.17	1225.44	1423.62	1477.19
				7,8,9	QBSF-2336-HNN	■ ■ ■ ■	1049.78	1065.84	1186.89	1236.16	1434.34	1487.91
		41 7/8"(1064mm)	42"(1067mm)	1	QBSF-2342-HNN	■ ■ ■ ■	\$1033.70	\$1051.90	\$1180.45	\$1232.93	\$1447.18	\$1506.11
				2,3	QBSF-2342-HNN	■ ■ ■ ■	1087.26	1105.46	1234.01	1286.49	1500.74	1559.67
				7,8,9	QBSF-2342-HNN	■ ■ ■ ■	1097.98	1116.18	1244.73	1297.21	1511.46	1570.39
Single — 2H												
24" H Hinged Door	29"(737mm)	23 7/8"(606mm)	24"(610mm)	2,3	QBSF-2924-JNN	■ ■ ■ ■	\$ 964.09	\$ 980.16	\$1092.63	\$1135.48	\$1322.94	\$1365.79
				7,8,9	QBSF-2924-JNN	■ ■ ■ ■	974.81	990.88	1103.35	1146.20	1333.66	1376.51
		29 7/8"(759mm)	30"(762mm)	1	QBSF-2930-JNN	■ ■ ■ ■	\$1036.93	\$1055.14	\$1175.11	\$1221.17	\$1424.70	\$1472.91
				2,3	QBSF-2930-JNN	■ ■ ■ ■	1090.49	1108.70	1228.67	1274.73	1478.26	1526.47
				7,8,9	QBSF-2930-JNN	■ ■ ■ ■	1101.21	1119.42	1239.39	1285.45	1488.98	1537.19
		35 7/8"(911mm)	36"(914mm)	1	QBSF-2936-JNN	■ ■ ■ ■	\$1163.33	\$1183.68	\$1311.15	\$1360.42	\$1580.02	\$1633.59
				2,3	QBSF-2936-JNN	■ ■ ■ ■	1216.89	1237.24	1364.71	1413.98	1633.58	1687.15
				7,8,9	QBSF-2936-JNN	■ ■ ■ ■	1227.61	1247.96	1375.43	1424.70	1644.30	1697.87
		41 7/8"(1064mm)	42"(1067mm)	1	QBSF-2942-JNN	■ ■ ■ ■	\$1289.73	\$1312.22	\$1447.19	\$1499.67	\$1735.34	\$1794.27
				2,3	QBSF-2942-JNN	■ ■ ■ ■	1343.29	1365.78	1500.75	1553.23	1788.90	1847.83
				7,8,9	QBSF-2942-JNN	■ ■ ■ ■	1354.01	1376.50	1511.47	1563.95	1799.62	1858.55
Double — 1H												
12"H Hinged Door Open — Right	17"(432mm)	47 7/8"(1216mm)	48"(1219mm)	2,3	QBDF-1748-GZN	■ ■ ■ ■	\$ 963.01	\$ 979.07	\$1108.69	\$1164.38	\$1373.27	\$1437.56
				7,8,9	QBDF-1748-GZN	■ ■ ■ ■	973.73	989.79	1119.41	1175.10	1383.99	1448.28
		59 7/8"(1826mm)	60"(1524mm)	1	QBDF-1760-GZN	■ ■ ■ ■	\$1063.71	\$1084.05	\$1228.67	\$1290.78	\$1531.81	\$1606.82
				2,3	QBDF-1760-GZN	■ ■ ■ ■	1117.27	1137.61	1282.23	1344.34	1585.37	1660.38
				7,8,9	QBDF-1760-GZN	■ ■ ■ ■	1127.99	1148.33	1292.95	1355.06	1596.09	1671.10
		71 7/8"(1826mm)	72"(1829mm)	1	QBDF-1772-GZN	■ ■ ■ ■	\$1217.97	\$1242.59	\$1402.21	\$1470.74	\$1743.91	\$1829.64
				2,3	QBDF-1772-GZN	■ ■ ■ ■	1271.53	1296.15	1455.77	1524.30	1797.47	1883.20
				7,8,9	QBDF-1772-GZN	■ ■ ■ ■	1282.25	1306.87	1466.49	1535.02	1808.19	1893.92
Open — Left 12"H Hinged Door	17"(432mm)	47 7/8"(1216mm)	48"(1219mm)	2,3	QBDF-1748-ZGN	■ ■ ■ ■	\$ 963.01	\$ 979.07	\$1108.69	\$1164.38	\$1373.27	\$1437.56
				7,8,9	QBDF-1748-ZGN	■ ■ ■ ■	973.73	989.79	1119.41	1175.10	1383.99	1448.28
		59 7/8"(1826mm)	60"(1524mm)	1	QBDF-1760-ZGN	■ ■ ■ ■	\$1063.71	\$1084.05	\$1228.67	\$1290.78	\$1531.81	\$1606.82
				2,3	QBDF-1760-ZGN	■ ■ ■ ■	1117.27	1137.61	1282.23	1344.34	1585.37	1660.38
				7,8,9	QBDF-1760-ZGN	■ ■ ■ ■	1127.99	1148.33	1292.95	1355.06	1596.09	1671.10
		71 7/8"(1826mm)	72"(1829mm)	1	QBDF-1772-ZGN	■ ■ ■ ■	\$1217.97	\$1242.59	\$1402.21	\$1470.74	\$1743.91	\$1829.64
				2,3	QBDF-1772-ZGN	■ ■ ■ ■	1271.53	1296.15	1455.77	1524.30	1797.47	1883.20
				7,8,9	QBDF-1772-ZGN	■ ■ ■ ■	1282.25	1306.87	1466.49	1535.02	1808.19	1893.92

*Finished Height includes worksurface top, spacer, base unit and legs

Base Unit — Hinged Door

Description	Finished Height*	Actual Width	Nominal Width	Pull	Number	Case Laminate A				Wood Door					
						Steel Door Trim A	Steel Door Trim B	Laminate Door A	Laminate Door B	Group A	Group B				
Double — 1.5H															
Open — Left 18"H Hinged Door	23"(584mm)	47 7/8"(1216mm)	48"(1219mm)	2,3	QBDF-2348-ZHN	■	■	■	■	\$1169.75	\$1190.09	\$1326.14	\$1381.83	\$1612.15	\$1676.44
				7,8,9	QBDF-2348-ZHN	■	■	■	■	1180.47	1200.81	1336.86	1392.55	1622.87	1687.16
	59 7/8"(1521mm)	60"(1524mm)		1	QBDF-2360-ZHN	■	■	■	■	\$1199.75	\$1224.37	\$1375.42	\$1437.53	\$1699.99	\$1775.00
				2,3	QBDF-2360-ZHN	■	■	■	■	1253.31	1277.93	1428.98	1491.09	1753.55	1828.56
				7,8,9	QBDF-2360-ZHN	■	■	■	■	1264.03	1288.65	1439.70	1501.81	1764.27	1839.28
	71 7/8"(1826mm)	72"(1829mm)		1	QBDF-2372-ZHN	■	■	■	■	\$1283.31	\$1312.21	\$1478.26	\$1546.79	\$1841.39	\$1927.12
				2,3	QBDF-2372-ZHN	■	■	■	■	1336.87	1365.77	1531.82	1600.35	1894.95	1980.68
				7,8,9	QBDF-2372-ZHN	■	■	■	■	1347.59	1376.49	1542.54	1611.07	1905.67	1991.40
18"H Hinged Door Open — Right	23"(584mm)	47 7/8"(1216mm)	48"(1219mm)	2,3	QBDF-2348-HZN	■	■	■	■	\$1169.75	\$1190.09	\$1326.14	\$1381.83	\$1612.15	\$1676.44
				7,8,9	QBDF-2348-HZN	■	■	■	■	1180.47	1200.81	1336.86	1392.55	1622.87	1687.16
	59 7/8"(1521mm)	60"(1524mm)		1	QBDF-2360-HZN	■	■	■	■	\$1199.75	\$1224.37	\$1375.42	\$1437.53	\$1699.99	\$1775.00
				2,3	QBDF-2360-HZN	■	■	■	■	1253.31	1277.93	1428.98	1491.09	1753.55	1828.56
				7,8,9	QBDF-2360-HZN	■	■	■	■	1264.03	1288.65	1439.70	1501.81	1764.27	1839.28
	71 7/8"(1826mm)	72"(1829mm)		1	QBDF-2372-HZN	■	■	■	■	\$1283.31	\$1312.21	\$1478.26	\$1546.79	\$1841.39	\$1927.12
				2,3	QBDF-2372-HZN	■	■	■	■	1336.87	1365.77	1531.82	1600.35	1894.95	1980.68
				7,8,9	QBDF-2372-HZN	■	■	■	■	1347.59	1376.49	1542.54	1611.07	1905.67	1991.40
Double — 2H															
Open — Left 24"H Hinged Door	29"(737mm)	47 7/8"(1216mm)	48"(1219mm)	2,3	QBDF-2948-ZJN	■	■	■	■	\$1437.55	\$1462.18	\$1604.65	\$1660.34	\$1912.08	\$1976.37
				7,8,9	QBDF-2948-ZJN	■	■	■	■	1448.27	1472.90	1615.37	1671.06	1922.80	1987.09
	59 7/8"(1521mm)	60"(1524mm)		1	QBDF-2960-ZJN	■	■	■	■	\$1476.11	\$1505.02	\$1662.49	\$1724.60	\$2008.48	\$2083.49
				2,3	QBDF-2960-ZJN	■	■	■	■	1529.67	1558.58	1716.05	1778.16	2062.04	2137.05
				7,8,9	QBDF-2960-ZJN	■	■	■	■	1540.39	1569.30	1726.77	1788.88	2072.76	2147.77
	71 7/8"(1826mm)	72"(1829mm)		1	QBDF-2972-ZJN	■	■	■	■	\$1568.23	\$1601.42	\$1773.89	\$1842.42	\$2158.44	\$2244.17
				2,3	QBDF-2972-ZJN	■	■	■	■	1621.79	1654.98	1827.45	1895.98	2212.00	2297.73
				7,8,9	QBDF-2972-ZJN	■	■	■	■	1632.51	1665.70	1838.17	1906.70	2222.72	2308.45
24"H Hinged Door Open — Right	29"(737mm)	47 7/8"(1216mm)	48"(1219mm)	2,3	QBDF-2948-JZN	■	■	■	■	\$1437.55	\$1462.18	\$1604.65	\$1660.34	\$1912.08	\$1976.37
				7,8,9	QBDF-2948-JZN	■	■	■	■	1448.27	1472.90	1615.37	1671.06	1922.80	1987.09
	59 7/8"(1521mm)	60"(1524mm)		1	QBDF-2960-JZN	■	■	■	■	\$1476.11	\$1505.02	\$1662.49	\$1724.60	\$2008.48	\$2083.49
				2,3	QBDF-2960-JZN	■	■	■	■	1529.67	1558.58	1716.05	1778.16	2062.04	2137.05
				7,8,9	QBDF-2960-JZN	■	■	■	■	1540.39	1569.30	1726.77	1788.88	2072.76	2147.77
	71 7/8"(1826mm)	72"(1829mm)		1	QBDF-2972-JZN	■	■	■	■	\$1568.23	\$1601.42	\$1773.89	\$1842.42	\$2158.44	\$2244.17
				2,3	QBDF-2972-JZN	■	■	■	■	1621.79	1654.98	1827.45	1895.98	2212.00	2297.73
				7,8,9	QBDF-2972-JZN	■	■	■	■	1632.51	1665.70	1838.17	1906.70	2222.72	2308.45
Triple — 1H															
Open/Hinged Door/Open	17"(432mm)	47 7/8"(1216mm)	48"(1219mm)	2,3	QBTF-1748-ZGZ	■	■	■	■	\$1461.12	\$1477.18	\$1720.35	\$1827.47	\$2154.19	\$2239.88
				7,8,9	QBTF-1748-ZGZ	■	■	■	■	1471.84	1487.90	1731.07	1838.19	2164.91	2250.60
	59 7/8"(1521mm)	60"(1524mm)		1	QBTF-1760-ZGZ	■	■	■	■	\$1465.40	\$1485.74	\$1740.70	\$1851.03	\$2201.32	\$2294.51
				2,3	QBTF-1760-ZGZ	■	■	■	■	1518.96	1539.30	1794.26	1904.59	2254.88	2348.07
				7,8,9	QBTF-1760-ZGZ	■	■	■	■	1529.68	1550.02	1804.98	1915.31	2265.60	2358.79
	71 7/8"(1826mm)	72"(1829mm)		1	QBTF-1772-ZGZ	■	■	■	■	\$1523.24	\$1547.86	\$1814.61	\$1928.15	\$2302.01	\$2402.70
				2,3	QBTF-1772-ZGZ	■	■	■	■	1576.80	1601.42	1868.17	1981.71	2355.57	2456.26
				7,8,9	QBTF-1772-ZGZ	■	■	■	■	1587.52	1612.14	1878.89	1992.43	2366.29	2466.98
Hinged Door/ Open/Hinged Door	17"(432mm)	47 7/8"(1216mm)	48"(1219mm)	2,3	QBTF-1748-GZG	■	■	■	■	\$1482.54	\$1498.60	\$1741.77	\$1848.89	\$2175.61	\$2261.30
				7,8,9	QBTF-1748-GZG	■	■	■	■	1493.26	1509.32	1752.49	1859.61	2186.33	2272.02
	59 7/8"(1521mm)	60"(1524mm)		1	QBTF-1760-GZG	■	■	■	■	\$1484.68	\$1505.02	\$1759.98	\$1870.31	\$2220.60	\$2313.79
				2,3	QBTF-1760-GZG	■	■	■	■	1538.24	1558.58	1813.54	1923.87	2274.16	2367.35
				7,8,9	QBTF-1760-GZG	■	■	■	■	1548.96	1569.30	1824.26	1934.59	2284.88	2378.07
	71 7/8"(1826mm)	72"(1829mm)		1	QBTF-1772-GZG	■	■	■	■	\$1540.38	\$1565.00	\$1831.75	\$1945.29	\$2319.15	\$2419.84
				2,3	QBTF-1772-GZG	■	■	■	■	1593.94	1618.56	1885.31	1998.85	2372.71	2473.40
				7,8,9	QBTF-1772-GZG	■	■	■	■	1604.66	1629.28	1896.03	2009.57	2383.43	2484.12

*Finished Height includes worksurface top, spacer, base unit and legs

Base Unit — Hinged Door

Description	Finished Height*	Actual Width	Nominal Width	Pull	Number	① ② ③ ④	Case Laminate A				Wood Door	
							Steel Door Trim A	Trim B	Laminate Door A	Door B	Group A	Group B
Hinged Door/ Hinged Door/ Hinged Door	17"(432mm)	47 7/8"(1216mm)	48"(1219mm)	2,3	QBTF-1748-GGG	■ ■ ■ ■	\$1487.90	\$1503.96	\$1747.13	\$1854.25	\$2180.97	\$2266.66
				7,8,9	QBTF-1748-GGG	■ ■ ■ ■	1493.26	1509.32	1752.49	1859.61	2186.33	2272.02
		59 7/8"(1521mm)	60"(1524mm)	1	QBTF-1760-GGG	■ ■ ■ ■	\$1516.82	\$1537.16	\$1792.12	\$1902.45	\$2252.74	\$2345.93
				2,3	QBTF-1760-GGG	■ ■ ■ ■	1543.60	1563.94	1818.90	1929.23	2279.52	2372.71
				7,8,9	QBTF-1760-GGG	■ ■ ■ ■	1548.96	1569.30	1824.26	1934.59	2284.88	2378.07
		71 7/8"(1826mm)	72"(1829mm)	1	QBTF-1772-GGG	■ ■ ■ ■	\$1572.52	\$1597.14	\$1863.89	\$1977.43	\$2351.29	\$2451.98
				2,3	QBTF-1772-GGG	■ ■ ■ ■	1599.30	1623.92	1890.67	2004.21	2378.07	2478.76
				7,8,9	QBTF-1772-GGG	■ ■ ■ ■	1604.66	1629.28	1896.03	2009.57	2383.43	2484.12
Triple — 1.5H												
Open/Hinged Door/Open	23"(584mm)	47 7/8"(1216mm)	48"(1219mm)	2,3	QBTF-2348-ZHZ	■ ■ ■ ■	\$1548.96	\$1569.30	\$1808.19	\$1915.31	\$2242.03	\$2327.72
				7,8,9	QBTF-2348-ZHZ	■ ■ ■ ■	1559.68	1580.02	1818.91	1926.03	2252.75	2338.44
		59 7/8"(1521mm)	60"(1524mm)	1	QBTF-2360-ZHZ	■ ■ ■ ■	\$1553.24	\$1577.86	\$1828.54	\$1938.87	\$2289.16	\$2382.35
				2,3	QBTF-2360-ZHZ	■ ■ ■ ■	1606.80	1631.42	1882.10	1992.43	2342.72	2435.91
				7,8,9	QBTF-2360-ZHZ	■ ■ ■ ■	1617.52	1642.14	1892.82	2003.15	2353.44	2446.63
		71 7/8"(1826mm)	72"(1829mm)	1	QBTF-2372-ZHZ	■ ■ ■ ■	\$1611.08	\$1639.98	\$1902.45	\$2015.99	\$2389.85	\$2490.54
				2,3	QBTF-2372-ZHZ	■ ■ ■ ■	1664.64	1693.54	1956.01	2069.55	2443.41	2544.10
				7,8,9	QBTF-2372-ZHZ	■ ■ ■ ■	1675.36	1704.26	1966.73	2080.27	2454.13	2554.82
Hinged Door/ Open/Hinged Door	23"(584mm)	47 7/8"(1216mm)	48"(1219mm)	2,3	QBTF-2348-HZH	■ ■ ■ ■	\$1570.38	\$1590.72	\$1829.61	\$1936.73	\$2263.45	\$2349.14
				7,8,9	QBTF-2348-HZH	■ ■ ■ ■	1581.10	1601.44	1840.33	1947.45	2274.17	2359.86
		59 7/8"(1521mm)	60"(1524mm)	1	QBTF-2360-HZH	■ ■ ■ ■	\$1572.52	\$1597.14	\$1847.82	\$1958.15	\$2308.44	\$2401.63
				2,3	QBTF-2360-HZH	■ ■ ■ ■	1626.08	1650.70	1901.38	2011.71	2362.00	2455.19
				7,8,9	QBTF-2360-HZH	■ ■ ■ ■	1636.80	1661.42	1912.10	2022.43	2372.72	2465.91
		71 7/8"(1826mm)	72"(1829mm)	1	QBTF-2372-HZH	■ ■ ■ ■	\$1628.22	\$1657.12	\$1919.59	\$2033.13	\$2406.99	\$2507.68
				2,3	QBTF-2372-HZH	■ ■ ■ ■	1681.78	1710.68	1973.15	2086.69	2460.55	2561.24
				7,8,9	QBTF-2372-HZH	■ ■ ■ ■	1692.50	1721.40	1983.87	2097.41	2471.27	2571.96
Hinged Door/ Hinged Door/ Hinged Door	23"(584mm)	47 7/8"(1216mm)	48"(1219mm)	2,3	QBTF-2348-HHH	■ ■ ■ ■	\$1575.74	\$1596.08	\$1834.97	\$1942.09	\$2268.81	\$2354.50
				7,8,9	QBTF-2348-HHH	■ ■ ■ ■	1581.10	1601.44	1840.33	1947.45	2274.17	2359.86
		59 7/8"(1521mm)	60"(1524mm)	1	QBTF-2360-HHH	■ ■ ■ ■	\$1604.66	\$1629.28	\$1879.96	\$1990.29	\$2340.58	\$2433.77
				2,3	QBTF-2360-HHH	■ ■ ■ ■	1631.44	1656.06	1906.74	2017.07	2367.36	2460.55
				7,8,9	QBTF-2360-HHH	■ ■ ■ ■	1636.80	1661.42	1912.10	2022.43	2372.72	2465.91
		71 7/8"(1826mm)	72"(1829mm)	1	QBTF-2372-HHH	■ ■ ■ ■	\$1660.36	\$1689.26	\$1951.73	\$2065.27	\$2439.13	\$2539.82
				2,3	QBTF-2372-HHH	■ ■ ■ ■	1687.14	1716.04	1978.51	2092.05	2465.91	2566.60
				7,8,9	QBTF-2372-HHH	■ ■ ■ ■	1692.50	1721.40	1983.87	2097.41	2471.27	2571.96

*Finished Height includes worksurface top, spacer, base unit and legs

Base Unit — Hinged Door

Description	Finished Height*	Actual Width	Nominal Width	Pull	Number	Case Laminate B				Steel Door Trim A	Trim B	Laminate Door		Wood Door	
						①	②	③	④			A	B	Group A	Group B
Single — 1H															
12"H Hinged Door	17"(432mm)	23 7/8"(606mm)	24"(610mm)	2,3	QBSF-1724-GNN	■	■	■	■	\$ 866.61	\$ 874.11	\$ 973.73	\$ 1016.58	\$ 1161.19	\$ 1204.04
				7,8,9	QBSF-1724-GNN	■	■	■	■	\$ 877.33	\$ 884.83	\$ 984.45	\$ 1027.30	\$ 1171.91	\$ 1214.76
		29 7/8"(759mm)	30"(762mm)	1	QBSF-1730-GNN	■	■	■	■	\$ 854.82	\$ 864.46	\$ 971.58	\$ 1017.64	\$ 1178.32	\$ 1226.53
				2,3	QBSF-1730-GNN	■	■	■	■	\$ 908.38	\$ 918.02	\$ 1025.14	\$ 1071.20	\$ 1231.88	\$ 1280.09
				7,8,9	QBSF-1730-GNN	■	■	■	■	\$ 919.10	\$ 928.74	\$ 1035.86	\$ 1081.92	\$ 1242.60	\$ 1290.81
		35 7/8"(911mm)	36"(914mm)	1	QBSF-1736-GNN	■	■	■	■	\$ 896.59	\$ 908.37	\$ 1022.99	\$ 1072.26	\$ 1249.01	\$ 1302.58
				2,3	QBSF-1736-GNN	■	■	■	■	\$ 950.15	\$ 961.93	\$ 1076.55	\$ 1125.82	\$ 1302.57	\$ 1356.14
				7,8,9	QBSF-1736-GNN	■	■	■	■	\$ 960.87	\$ 972.65	\$ 1087.27	\$ 1136.54	\$ 1313.29	\$ 1366.86
		41 7/8"(1064mm)	42"(1067mm)	1	QBSF-1742-GNN	■	■	■	■	\$ 938.36	\$ 952.28	\$ 1074.40	\$ 1126.88	\$ 1319.70	\$ 1378.63
				2,3	QBSF-1742-GNN	■	■	■	■	\$ 991.92	\$ 1005.84	\$ 1127.96	\$ 1180.44	\$ 1373.26	\$ 1432.19
				7,8,9	QBSF-1742-GNN	■	■	■	■	\$ 1002.64	\$ 1016.56	\$ 1138.68	\$ 1191.16	\$ 1383.98	\$ 1442.91
Single — 1.5H															
18"H Hinged Door	23"(584mm)	23 7/8"(606mm)	24"(610mm)	2,3	QBSF-2324-HNN	■	■	■	■	\$ 990.86	\$ 1002.64	\$ 1108.69	\$ 1151.54	\$ 1317.58	\$ 1360.43
				7,8,9	QBSF-2324-HNN	■	■	■	■	\$ 1001.58	\$ 1013.36	\$ 1119.41	\$ 1162.26	\$ 1328.30	\$ 1371.15
		29 7/8"(759mm)	30"(762mm)	1	QBSF-2330-HNN	■	■	■	■	\$ 987.64	\$ 1001.56	\$ 1115.11	\$ 1161.17	\$ 1343.28	\$ 1391.49
				2,3	QBSF-2330-HNN	■	■	■	■	\$ 1041.20	\$ 1055.12	\$ 1168.67	\$ 1214.73	\$ 1396.84	\$ 1445.05
				7,8,9	QBSF-2330-HNN	■	■	■	■	\$ 1051.92	\$ 1065.84	\$ 1179.39	\$ 1225.45	\$ 1407.56	\$ 1455.77
		35 7/8"(911mm)	36"(914mm)	1	QBSF-2336-HNN	■	■	■	■	\$ 1037.98	\$ 1054.04	\$ 1175.09	\$ 1224.36	\$ 1422.54	\$ 1476.11
				2,3	QBSF-2336-HNN	■	■	■	■	\$ 1091.54	\$ 1107.60	\$ 1228.65	\$ 1277.92	\$ 1476.10	\$ 1529.67
				7,8,9	QBSF-2336-HNN	■	■	■	■	\$ 1102.26	\$ 1118.32	\$ 1239.37	\$ 1288.64	\$ 1486.82	\$ 1540.39
		41 7/8"(1064mm)	42"(1067mm)	1	QBSF-2342-HNN	■	■	■	■	\$ 1088.32	\$ 1106.52	\$ 1235.07	\$ 1287.55	\$ 1501.80	\$ 1560.73
				2,3	QBSF-2342-HNN	■	■	■	■	\$ 1141.88	\$ 1160.08	\$ 1288.63	\$ 1341.11	\$ 1555.36	\$ 1614.29
				7,8,9	QBSF-2342-HNN	■	■	■	■	\$ 1152.60	\$ 1170.80	\$ 1299.35	\$ 1351.83	\$ 1566.08	\$ 1625.01
Single — 2H															
24" H Hinged Door	29"(737mm)	23 7/8"(606mm)	24"(610mm)	2,3	QBSF-2924-JNN	■	■	■	■	\$ 1018.72	\$ 1034.79	\$ 1147.26	\$ 1190.11	\$ 1377.57	\$ 1420.42
				7,8,9	QBSF-2924-JNN	■	■	■	■	\$ 1029.44	\$ 1045.51	\$ 1157.98	\$ 1200.83	\$ 1388.29	\$ 1431.14
		29 7/8"(759mm)	30"(762mm)	1	QBSF-2930-JNN	■	■	■	■	\$ 1093.70	\$ 1111.91	\$ 1231.88	\$ 1277.94	\$ 1481.47	\$ 1529.68
				2,3	QBSF-2930-JNN	■	■	■	■	\$ 1147.26	\$ 1165.47	\$ 1285.44	\$ 1331.50	\$ 1535.03	\$ 1583.24
				7,8,9	QBSF-2930-JNN	■	■	■	■	\$ 1157.98	\$ 1176.19	\$ 1296.16	\$ 1342.22	\$ 1545.75	\$ 1593.96
		35 7/8"(911mm)	36"(914mm)	1	QBSF-2936-JNN	■	■	■	■	\$ 1222.24	\$ 1242.59	\$ 1370.06	\$ 1419.33	\$ 1638.93	\$ 1692.50
				2,3	QBSF-2936-JNN	■	■	■	■	\$ 1275.80	\$ 1296.15	\$ 1423.62	\$ 1472.89	\$ 1692.49	\$ 1746.06
				7,8,9	QBSF-2936-JNN	■	■	■	■	\$ 1286.52	\$ 1306.87	\$ 1434.34	\$ 1483.61	\$ 1703.21	\$ 1756.78
		41 7/8"(1064mm)	42"(1067mm)	1	QBSF-2942-JNN	■	■	■	■	\$ 1350.78	\$ 1373.27	\$ 1508.24	\$ 1560.72	\$ 1796.39	\$ 1855.32
				2,3	QBSF-2942-JNN	■	■	■	■	\$ 1404.34	\$ 1426.83	\$ 1561.80	\$ 1614.28	\$ 1849.95	\$ 1908.88
				7,8,9	QBSF-2942-JNN	■	■	■	■	\$ 1415.06	\$ 1437.55	\$ 1572.52	\$ 1625.00	\$ 1860.67	\$ 1919.60
Double — 1H															
12"H Hinged Door Open — Right	17"(432mm)	47 7/8"(1216mm)	48"(1219mm)	2,3	QBDF-1748-GZN	■	■	■	■	\$ 1013.35	\$ 1029.41	\$ 1159.03	\$ 1214.72	\$ 1423.61	\$ 1487.90
				7,8,9	QBDF-1748-GZN	■	■	■	■	\$ 1024.07	\$ 1040.13	\$ 1169.75	\$ 1225.44	\$ 1434.33	\$ 1498.62
		59 7/8"(1826mm)	60"(1524mm)	1	QBDF-1760-GZN	■	■	■	■	\$ 1118.33	\$ 1138.67	\$ 1283.29	\$ 1345.40	\$ 1586.43	\$ 1661.44
				2,3	QBDF-1760-GZN	■	■	■	■	\$ 1171.89	\$ 1192.23	\$ 1336.85	\$ 1398.96	\$ 1639.99	\$ 1715.00
				7,8,9	QBDF-1760-GZN	■	■	■	■	\$ 1182.61	\$ 1202.95	\$ 1347.57	\$ 1409.68	\$ 1650.71	\$ 1725.72
		71 7/8"(1826mm)	72"(1829mm)	1	QBDF-1772-GZN	■	■	■	■	\$ 1276.87	\$ 1301.49	\$ 1461.11	\$ 1529.64	\$ 1802.81	\$ 1888.54
				2,3	QBDF-1772-GZN	■	■	■	■	\$ 1330.43	\$ 1355.05	\$ 1514.67	\$ 1583.20	\$ 1856.37	\$ 1942.10
				7,8,9	QBDF-1772-GZN	■	■	■	■	\$ 1341.15	\$ 1365.77	\$ 1525.39	\$ 1593.92	\$ 1867.09	\$ 1952.82
Open — Left 12"H Hinged Door	17"(432mm)	47 7/8"(1216mm)	48"(1219mm)	2,3	QBDF-1748-GZN	■	■	■	■	\$ 1013.35	\$ 1029.41	\$ 1159.03	\$ 1214.72	\$ 1423.61	\$ 1487.90
				7,8,9	QBDF-1748-GZN	■	■	■	■	\$ 1024.07	\$ 1040.13	\$ 1169.75	\$ 1225.44	\$ 1434.33	\$ 1498.62
		59 7/8"(1826mm)	60"(1524mm)	1	QBDF-1760-GZN	■	■	■	■	\$ 1118.33	\$ 1138.67	\$ 1283.29	\$ 1345.40	\$ 1586.43	\$ 1661.44
				2,3	QBDF-1760-GZN	■	■	■	■	\$ 1171.89	\$ 1192.23	\$ 1336.85	\$ 1398.96	\$ 1639.99	\$ 1715.00
				7,8,9	QBDF-1760-GZN	■	■	■	■	\$ 1182.61	\$ 1202.95	\$ 1347.57	\$ 1409.68	\$ 1650.71	\$ 1725.72
		71 7/8"(1826mm)	72"(1829mm)	1	QBDF-1772-GZN	■	■	■	■	\$ 1276.87	\$ 1301.49	\$ 1461.11	\$ 1529.64	\$ 1802.81	\$ 1888.54
				2,3	QBDF-1772-GZN	■	■	■	■	\$ 1330.43	\$ 1355.05	\$ 1514.67	\$ 1583.20	\$ 1856.37	\$ 1942.10
				7,8,9	QBDF-1772-GZN	■	■	■	■	\$ 1341.15	\$ 1365.77	\$ 1525.39	\$ 1593.92	\$ 1867.09	\$ 1952.82

*Finished Height includes worksurface top, spacer, base unit and legs

Base Unit — Hinged Door

Description	Finished Height*	Actual Width	Nominal Width	Pull	Number	Case Laminate B				Wood Door					
						Steel Door Trim A	Steel Door Trim B	Laminate Door A	Laminate Door B	Group A	Group B				
Double — 1.5H															
Open — Left 18"H Hinged Door	23"(584mm)	47 7/8"(1216mm)	48"(1219mm)	2,3	QBDF-2348-ZHN	■	■	■	■	\$1226.51	\$1246.85	\$1382.90	\$1438.59	\$1668.91	\$1733.20
				7,8,9	QBDF-2348-ZHN	■	■	■	■	1237.23	1257.57	1393.62	1449.31	1679.63	1743.92
	59 7/8"(1521mm)	60"(1524mm)		1	QBDF-2360-ZHN	■	■	■	■	\$1260.79	\$1285.41	\$1436.46	\$1498.57	\$1761.03	\$1836.04
				2,3	QBDF-2360-ZHN	■	■	■	■	1314.35	1338.97	1490.02	1552.13	1814.59	1889.60
				7,8,9	QBDF-2360-ZHN	■	■	■	■	1325.07	1349.69	1500.74	1562.85	1825.31	1900.32
	71 7/8"(1826mm)	72"(1829mm)		1	QBDF-2372-ZHN	■	■	■	■	\$1348.63	\$1377.53	\$1543.58	\$1612.11	\$1906.71	\$1992.44
				2,3	QBDF-2372-ZHN	■	■	■	■	1402.19	1431.09	1597.14	1665.67	1960.27	2046.00
				7,8,9	QBDF-2372-ZHN	■	■	■	■	1412.91	1441.81	1607.86	1676.39	1970.99	2056.72
18"H Hinged Door Open — Right	23"(584mm)	47 7/8"(1216mm)	48"(1219mm)	2,3	QBDF-2348-HZN	■	■	■	■	\$1226.51	\$1246.85	\$1382.90	\$1438.59	\$1668.91	\$1733.20
				7,8,9	QBDF-2348-HZN	■	■	■	■	1237.23	1257.57	1393.62	1449.31	1679.63	1743.92
	59 7/8"(1521mm)	60"(1524mm)		1	QBDF-2360-HZN	■	■	■	■	\$1260.79	\$1285.41	\$1436.46	\$1498.57	\$1761.03	\$1836.04
				2,3	QBDF-2360-HZN	■	■	■	■	1314.35	1338.97	1490.02	1552.13	1814.59	1889.60
				7,8,9	QBDF-2360-HZN	■	■	■	■	1325.07	1349.69	1500.74	1562.85	1825.31	1900.32
	71 7/8"(1826mm)	72"(1829mm)		1	QBDF-2372-HZN	■	■	■	■	\$1348.63	\$1377.53	\$1543.58	\$1612.11	\$1906.71	\$1992.44
				2,3	QBDF-2372-HZN	■	■	■	■	1402.19	1431.09	1597.14	1665.67	1960.27	2046.00
				7,8,9	QBDF-2372-HZN	■	■	■	■	1412.91	1441.81	1607.86	1676.39	1970.99	2056.72
Double — 2H															
Open — Left 24"H Hinged Door	29"(737mm)	47 7/8"(1216mm)	48"(1219mm)	2,3	QBDF-2948-ZJN	■	■	■	■	\$1500.74	\$1525.37	\$1667.84	\$1723.53	\$1975.27	\$2039.56
				7,8,9	QBDF-2948-ZJN	■	■	■	■	1511.46	1536.09	1678.56	1734.25	1985.99	2050.28
	59 7/8"(1521mm)	60"(1524mm)		1	QBDF-2960-ZJN	■	■	■	■	\$1543.58	\$1572.49	\$1729.96	\$1792.07	\$2075.95	\$2150.96
				2,3	QBDF-2960-ZJN	■	■	■	■	1597.14	1626.05	1783.52	1845.63	2129.51	2204.52
				7,8,9	QBDF-2960-ZJN	■	■	■	■	1607.86	1636.77	1794.24	1856.35	2140.23	2215.24
	71 7/8"(1826mm)	72"(1829mm)		1	QBDF-2972-ZJN	■	■	■	■	\$1639.98	\$1673.17	\$1845.64	\$1914.17	\$2230.19	\$2315.92
				2,3	QBDF-2972-ZJN	■	■	■	■	1693.54	1726.73	1899.20	1967.73	2283.75	2369.48
				7,8,9	QBDF-2972-ZJN	■	■	■	■	1704.26	1737.45	1909.92	1978.45	2294.47	2380.20
24"H Hinged Door Open — Right	29"(737mm)	47 7/8"(1216mm)	48"(1219mm)	2,3	QBDF-2948-JZN	■	■	■	■	\$1500.74	\$1525.37	\$1667.84	\$1723.53	\$1975.27	\$2039.56
				7,8,9	QBDF-2948-JZN	■	■	■	■	1511.46	1536.09	1678.56	1734.25	1985.99	2050.28
	59 7/8"(1521mm)	60"(1524mm)		1	QBDF-2960-JZN	■	■	■	■	\$1543.58	\$1572.49	\$1729.96	\$1792.07	\$2075.95	\$2150.96
				2,3	QBDF-2960-JZN	■	■	■	■	1597.14	1626.05	1783.52	1845.63	2129.51	2204.52
				7,8,9	QBDF-2960-JZN	■	■	■	■	1607.86	1636.77	1794.24	1856.35	2140.23	2215.24
	71 7/8"(1826mm)	72"(1829mm)		1	QBDF-2972-JZN	■	■	■	■	\$1639.98	\$1673.17	\$1845.64	\$1914.17	\$2230.19	\$2315.92
				2,3	QBDF-2972-JZN	■	■	■	■	1693.54	1726.73	1899.20	1967.73	2283.75	2369.48
				7,8,9	QBDF-2972-JZN	■	■	■	■	1704.26	1737.45	1909.92	1978.45	2294.47	2380.20
Triple — 1H															
Open/Hinged Door/Open	17"(432mm)	47 7/8"(1216mm)	48"(1219mm)	2,3	QBTF-1748-ZGZ	■	■	■	■	\$1511.46	\$1527.52	\$1770.69	\$1877.81	\$2204.53	\$2290.22
				7,8,9	QBTF-1748-ZGZ	■	■	■	■	1522.18	1538.24	1781.41	1888.53	2215.25	2300.94
	59 7/8"(1521mm)	60"(1524mm)		1	QBTF-1760-ZGZ	■	■	■	■	\$1520.02	\$1540.36	\$1795.32	\$1905.65	\$2255.94	\$2349.13
				2,3	QBTF-1760-ZGZ	■	■	■	■	1573.58	1593.92	1848.88	1959.21	2309.50	2402.69
				7,8,9	QBTF-1760-ZGZ	■	■	■	■	1584.30	1604.64	1859.60	1969.93	2320.22	2413.41
	71 7/8"(1826mm)	72"(1829mm)		1	QBTF-1772-ZGZ	■	■	■	■	\$1582.14	\$1606.76	\$1873.51	\$1987.05	\$2360.91	\$2461.60
				2,3	QBTF-1772-ZGZ	■	■	■	■	1635.70	1660.32	1927.07	2040.61	2414.47	2515.16
				7,8,9	QBTF-1772-ZGZ	■	■	■	■	1646.42	1671.04	1937.79	2051.33	2425.19	2525.88
Hinged Door/ Open/Hinged Door	17"(432mm)	47 7/8"(1216mm)	48"(1219mm)	2,3	QBTF-1748-GZG	■	■	■	■	\$1532.88	\$1548.94	\$1792.11	\$1899.23	\$2225.95	\$2311.64
				7,8,9	QBTF-1748-GZG	■	■	■	■	1543.60	1559.66	1802.83	1909.95	2236.67	2322.36
	59 7/8"(1521mm)	60"(1524mm)		1	QBTF-1760-GZG	■	■	■	■	\$1539.30	\$1559.64	\$1814.60	\$1924.93	\$2275.22	\$2368.41
				2,3	QBTF-1760-GZG	■	■	■	■	1592.86	1613.20	1868.16	1978.49	2328.78	2421.97
				7,8,9	QBTF-1760-GZG	■	■	■	■	1603.58	1623.92	1878.88	1989.21	2339.50	2432.69
	71 7/8"(1826mm)	72"(1829mm)		1	QBTF-1772-GZG	■	■	■	■	\$1599.28	\$1623.90	\$1890.65	\$2004.19	\$2378.05	\$2478.74
				2,3	QBTF-1772-GZG	■	■	■	■	1652.84	1677.46	1944.21	2057.75	2431.61	2532.30
				7,8,9	QBTF-1772-GZG	■	■	■	■	1663.56	1688.18	1954.93	2068.47	2442.33	2543.02

*Finished Height includes worksurface top, spacer, base unit and legs

Base Unit — Hinged Door

Description	Finished Height*	Actual Width	Nominal Width	Pull	Number	Case Laminate B				Wood Door					
						Steel Door Trim A	Steel Door Trim B	Laminate Door A	Laminate Door B	Group A	Group B				
Hinged Door/ Hinged Door/ Hinged Door	17"(432mm)	47 7/8"(1216mm)	48"(1219mm)	2,3	QBTF-1748-GGG	1	2	3	4	\$1538.24	\$1554.30	\$1797.47	\$1904.59	\$2231.31	\$2317.00
				7,8,9	QBTF-1748-GGG					1543.60	1559.66	1802.83	1909.95	2236.67	2322.36
		59 7/8"(1521mm)	60"(1524mm)	1	QBTF-1760-GGG					\$1571.44	\$1591.78	\$1846.74	\$1957.07	\$2307.36	\$2400.55
				2,3	QBTF-1760-GGG					1598.22	1618.56	1873.52	1983.85	2334.14	2427.33
				7,8,9	QBTF-1760-GGG					1603.58	1623.92	1878.88	1989.21	2339.50	2432.69
		71 7/8"(1826mm)	72"(1829mm)	1	QBTF-1772-GGG					\$1631.42	\$1656.04	\$1922.79	\$2036.33	\$2410.19	\$2510.88
				2,3	QBTF-1772-GGG					1658.20	1682.82	1949.57	2063.11	2436.97	2537.66
				7,8,9	QBTF-1772-GGG					1663.56	1688.18	1954.93	2068.47	2442.33	2543.02
Triple — 1.5H															
Open/Hinged Door/Open	23"(584mm)	47 7/8"(1216mm)	48"(1219mm)	2,3	QBTF-2348-ZHZ					\$1605.72	\$1626.06	\$1864.95	\$1972.07	\$2298.79	\$2384.48
				7,8,9	QBTF-2348-ZHZ					1616.44	1636.78	1875.67	1982.79	2309.51	2395.20
		59 7/8"(1521mm)	60"(1524mm)	1	QBTF-2360-ZHZ					\$1614.28	\$1638.90	\$1889.58	\$1999.91	\$2350.20	\$2443.39
				2,3	QBTF-2360-ZHZ					1667.84	1692.46	1943.14	2053.47	2403.76	2496.95
				7,8,9	QBTF-2360-ZHZ					1678.56	1703.18	1953.86	2064.19	2414.48	2507.67
		71 7/8"(1826mm)	72"(1829mm)	1	QBTF-2372-ZHZ					\$1676.40	\$1705.30	\$1967.77	\$2081.31	\$2455.17	\$2555.86
				2,3	QBTF-2372-ZHZ					1729.96	1758.86	2021.33	2134.87	2508.73	2609.42
				7,8,9	QBTF-2372-ZHZ					1740.68	1769.58	2032.05	2145.59	2519.45	2620.14
Hinged Door/ Open/Hinged Door	23"(584mm)	47 7/8"(1216mm)	48"(1219mm)	2,3	QBTF-2348-HZH					\$1627.14	\$1647.48	\$1886.37	\$1993.49	\$2320.21	\$2405.90
				7,8,9	QBTF-2348-HZH					1637.86	1658.20	1897.09	2004.21	2330.93	2416.62
		59 7/8"(1521mm)	60"(1524mm)	1	QBTF-2360-HZH					\$1633.56	\$1658.18	\$1908.86	\$2019.19	\$2369.48	\$2462.67
				2,3	QBTF-2360-HZH					1687.12	1711.74	1962.42	2072.75	2423.04	2516.23
				7,8,9	QBTF-2360-HZH					1697.84	1722.46	1973.14	2083.47	2433.76	2526.95
		71 7/8"(1826mm)	72"(1829mm)	1	QBTF-2372-HZH					\$1693.54	\$1722.44	\$1984.91	\$2098.45	\$2472.31	\$2573.00
				2,3	QBTF-2372-HZH					1747.10	1776.00	2038.47	2152.01	2525.87	2626.56
				7,8,9	QBTF-2372-HZH					1757.82	1786.72	2049.19	2162.73	2536.59	2637.28
Hinged Door/ Hinged Door/ Hinged Door	23"(584mm)	47 7/8"(1216mm)	48"(1219mm)	2,3	QBTF-2348-HHH					\$1632.50	\$1652.84	\$1891.73	\$1998.85	\$2325.57	\$2411.26
				7,8,9	QBTF-2348-HHH					1637.86	1658.20	1897.09	2004.21	2330.93	2416.62
		59 7/8"(1521mm)	60"(1524mm)	1	QBTF-2360-HHH					\$1665.70	\$1690.32	\$1941.00	\$2051.33	\$2401.62	\$2494.81
				2,3	QBTF-2360-HHH					1692.48	1717.10	1967.78	2078.11	2428.40	2521.59
				7,8,9	QBTF-2360-HHH					1697.84	1722.46	1973.14	2083.47	2433.76	2526.95
		71 7/8"(1826mm)	72"(1829mm)	1	QBTF-2372-HHH					\$1725.68	\$1754.58	\$2017.05	\$2130.59	\$2504.45	\$2605.14
				2,3	QBTF-2372-HHH					1752.46	1781.36	2043.83	2157.37	2531.23	2631.92
				7,8,9	QBTF-2372-HHH					1757.82	1786.72	2049.19	2162.73	2536.59	2637.28

*Finished Height includes worksurface top, spacer, base unit and legs

Base Unit — Hinged Door and Open Storage Unit

Hinged Door — Open Storage Unit Features

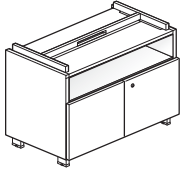

QB5F-XXXX-KNN

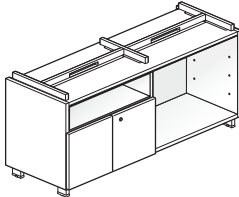

QBDF-XXXX-KZN

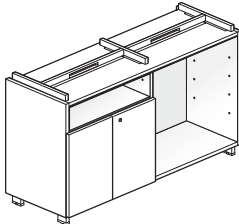

QBDF-XXXX-LZN

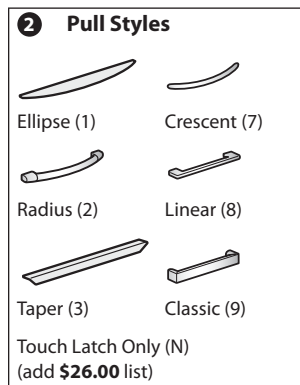

- Hinged Door Single Base Unit include:
 - Laminate case standard with a painted steel inset back and base.
 - Full access hinges that open 100 degrees.
 - If specified right-hand door includes touch latch mechanism (free swing hinge).
 - If specified left-hand door includes full length return flange (self-closing hinge).
 - Leg and drawer options.
 - Spacer
- Ellipse pull available in non-metallic color only. (see finish page for pull color)
- Radius pull available in metallic colors only. (see finish page for pull color)
- Leg Options:
 - Straight Leg (F); requires trim color.
 - Chamfer Leg (P); requires trim color.
- Glide adjustment range:
 - Straight Leg: 1.5”(38mm)
 - Chamfer Leg: 1.25”(32mm)
- Spacer:
 - 1.18”(30mm) high
 - End pieces come in specified color; center spacer section black only.
- Optional door fronts include painted, laminate or wood.
- Lock plugs:
 - Locking (chrome only) and non-locking available.
 - Single and double base units have one lock.
 - Triple base units may have more than one lock.
- Case ships assembled. Legs require field installation.

Specification Tips

- Designed to be used with Haworth's Integrated Palette, UniGroup Too, PREMISE, Reside Desking and/or Belong Work Tools.
- Beside base units 24”-42”(610mm-1067mm) cannot be freestanding. Units must be attached or ganged together. All base units with drawers must be attached. Refer to Specification Guide for planning information.
- Beside base units 48”-72”(1219mm-1829mm) widths can be freestanding.
- Separately specified storage tops are required and can match the width of a single base unit or span two or more adjacent base units side by side.
- To route and access power in storage, order separately specified Belong power components.
- 1.5H and 2H storage can be used to support Reside desking or Adaptable worksurface in a perpendicular configuration with separately specified brackets. Refer to Specification Guide for planning information.
- Beside base storage unit with top, spacer, base unit and legs finished heights:
 - 1H = 17”(432mm)
 - 1.5H = 23”(584mm)
 - 2H = 29”(737mm)
- Separately specified if applicable:
 - Belong Power and communication cabling, tools, screens and tool rails.
 - Storage-to-Panel Bracket
 - Storage Attachment Bracket
 - Ganging Bracket
 - Storage Top (required)
 - Filler Panel
 - Top Filler Track
 - Finished Back (recommended when back is exposed)
 - Adjustable Shelf (not included with unit)
 - Stack-On Hutch
- Refer to Specification Guide for planning information and actual dimensions.

Notes: 2H storage base units are not designed to fit under Reside benching or return worksurfaces. They can only attach to these surfaces.

Separately specified Belong base unit power components available for 30”-72”(372mm-1829mm) widths.

Storage shelves are unique to the specific base unit configuration. Refer to shelf price list pages for appropriate shelf.

To Order, Specify:

Steel, Laminate or Wood Door Front

1) Product number, including:

1 Door Front Option:

- S** Steel
- L** Laminate
- W** Veneer

2 Pull Option: (see side bar)

3 Leg Option:

- F** Straight Leg
- P** Chamfer Leg, add **\$85.70** list

4 Lock Option:

- L** Locking, add **\$42.85** list
- N** Non-Locking

2) Case laminate color.

3) Case laminate edgeband color.

4) Bottom, inset back, fixed shelf trim color.

5) Pull, leg, and spacer trim color.

6) Door front color.

7) Laminate door front edgeband color.

Note: Upcharge for mixed grade fabric or trim surfaces, refer to the electronic design and specification tools for pricing.

Base Unit — Hinged Door and Open Storage Unit

Description	Finished Height*	Actual Width	Nominal Width	Pull	Number	Case Laminate A				Wood Door Group A	Wood Door Group B	
						Steel Door Trim A	Steel Door Trim B	Laminate Door A	Laminate Door B			
Single — 1.5H												
6" Open/12"H Hinged Door	23"(584mm)	23 7/8"(606mm)	24"(610mm)	2,3	QBSF-2324-KNN	■ ■ ■ ■	\$ 834.47	\$ 846.25	\$ 952.30	\$ 995.15	\$1161.19	\$1204.04
				7,8,9	QBSF-2324-KNN	■ ■ ■ ■	845.19	856.97	963.02	1005.87	1171.91	1214.76
	29 7/8"(759mm)	30"(762mm)		1	QBSF-2330-KNN	■ ■ ■ ■	836.61	850.53	964.08	1010.14	1192.25	1240.46
				2,3	QBSF-2330-KNN	■ ■ ■ ■	890.17	904.09	1017.64	1063.70	1245.81	1294.02
				7,8,9	QBSF-2330-KNN	■ ■ ■ ■	900.89	914.81	1028.36	1074.42	1256.53	1304.74
	35 7/8"(911mm)	36"(914mm)		1	QBSF-2336-KNN	■ ■ ■ ■	\$ 892.31	\$ 908.37	\$1029.42	\$1078.69	\$1276.87	\$1330.44
				2,3	QBSF-2336-KNN	■ ■ ■ ■	945.87	961.93	1082.98	1132.25	1330.43	1384.00
				7,8,9	QBSF-2336-KNN	■ ■ ■ ■	956.59	972.65	1093.70	1142.97	1341.15	1394.72
	41 7/8"(1064mm)	42"(1067mm)		1	QBSF-2342-KNN	■ ■ ■ ■	\$ 948.01	\$ 966.21	\$1094.76	\$1147.24	\$1361.49	\$1420.42
				2,3	QBSF-2342-KNN	■ ■ ■ ■	1001.57	1019.77	1148.32	1200.80	1415.05	1473.98
				7,8,9	QBSF-2342-KNN	■ ■ ■ ■	1012.29	1030.49	1159.04	1211.52	1425.77	1484.70
Single — 2H												
6" Open/18"H Hinged Door	29"(737mm)	23 7/8"(606mm)	24"(610mm)	2,3	QBSF-2924-LNN	■ ■ ■ ■	\$ 937.31	\$ 953.38	\$1065.85	\$1108.70	\$1296.16	\$1339.01
				7,8,9	QBSF-2924-LNN	■ ■ ■ ■	948.03	964.10	1076.57	1119.42	1306.88	1349.73
	29 7/8"(759mm)	30"(762mm)		1	QBSF-2930-LNN	■ ■ ■ ■	\$ 931.95	\$ 950.16	\$1070.13	\$1116.19	\$1319.72	\$1367.93
				2,3	QBSF-2930-LNN	■ ■ ■ ■	985.51	1003.72	1123.69	1169.75	1373.28	1421.49
				7,8,9	QBSF-2930-LNN	■ ■ ■ ■	996.23	1014.44	1134.41	1180.47	1384.00	1432.21
	35 7/8"(911mm)	36"(914mm)		1	QBSF-2936-LNN	■ ■ ■ ■	\$ 980.15	\$1000.50	\$1127.97	\$1177.24	\$1396.84	\$1450.41
				2,3	QBSF-2936-LNN	■ ■ ■ ■	1033.71	1054.06	1181.53	1230.80	1450.40	1503.97
				7,8,9	QBSF-2936-LNN	■ ■ ■ ■	1044.43	1064.78	1192.25	1241.52	1461.12	1514.69
	41 7/8"(1064mm)	42"(1067mm)		1	QBSF-2942-LNN	■ ■ ■ ■	\$1028.35	\$1050.84	\$1185.81	\$1238.29	\$1473.96	\$1532.89
				2,3	QBSF-2942-LNN	■ ■ ■ ■	1081.91	1104.40	1239.37	1291.85	1527.52	1586.45
				7,8,9	QBSF-2942-LNN	■ ■ ■ ■	1092.63	1115.12	1250.09	1302.57	1538.24	1597.17
12" Open/12"H Hinged Door	29"(737mm)	23 7/8"(606mm)	24"(610mm)	2,3	QBSF-2924-KNN	■ ■ ■ ■	\$ 937.31	\$ 953.38	\$1065.85	\$1108.70	\$1296.16	\$1339.01
				7,8,9	QBSF-2924-KNN	■ ■ ■ ■	948.03	964.10	1076.57	1119.42	1306.88	1349.73
	29 7/8"(759mm)	30"(762mm)		1	QBSF-2930-KNN	■ ■ ■ ■	\$ 931.95	\$ 950.16	\$1070.13	\$1116.19	\$1319.72	\$1367.93
				2,3	QBSF-2930-KNN	■ ■ ■ ■	985.51	1003.72	1123.69	1169.75	1373.28	1421.49
				7,8,9	QBSF-2930-KNN	■ ■ ■ ■	996.23	1014.44	1134.41	1180.47	1384.00	1432.21
	35 7/8"(911mm)	36"(914mm)		1	QBSF-2936-KNN	■ ■ ■ ■	\$ 980.15	\$1000.50	\$1127.97	\$1177.24	\$1396.84	\$1450.41
				2,3	QBSF-2936-KNN	■ ■ ■ ■	1033.71	1054.06	1181.53	1230.80	1450.40	1503.97
				7,8,9	QBSF-2936-KNN	■ ■ ■ ■	1044.43	1064.78	1192.25	1241.52	1461.12	1514.69
	41 7/8"(1064mm)	42"(1067mm)		1	QBSF-2942-KNN	■ ■ ■ ■	\$1028.35	\$1050.84	\$1185.81	\$1238.29	\$1473.96	\$1532.89
				2,3	QBSF-2942-KNN	■ ■ ■ ■	1081.91	1104.40	1239.37	1291.85	1527.52	1586.45
				7,8,9	QBSF-2942-KNN	■ ■ ■ ■	1092.63	1115.12	1250.09	1302.57	1538.24	1597.17
Double — 1.5H												
Open — Left 6" Open/12"H Hinged Door	23"(584mm)	47 7/8"(1216mm)	48"(1219mm)	2,3	QBDF-2348-ZKN	■ ■ ■ ■	\$1030.50	\$1050.84	\$1186.89	\$1242.58	\$1472.90	\$1537.19
				7,8,9	QBDF-2348-ZKN	■ ■ ■ ■	1041.22	1061.56	1197.61	1253.30	1483.62	1547.91
	59 7/8"(1521mm)	60"(1524mm)		1	QBDF-2360-ZKN	■ ■ ■ ■	\$1039.06	\$1063.68	\$1214.73	\$1276.84	\$1539.30	\$1614.31
				2,3	QBDF-2360-ZKN	■ ■ ■ ■	1092.62	1117.24	1268.29	1330.40	1592.86	1667.87
				7,8,9	QBDF-2360-ZKN	■ ■ ■ ■	1103.34	1127.96	1279.01	1341.12	1603.58	1678.59
	71 7/8"(1826mm)	72"(1829mm)		1	QBDF-2372-ZKN	■ ■ ■ ■	\$1101.18	\$1130.08	\$1296.13	\$1364.66	\$1659.26	\$1744.99
				2,3	QBDF-2372-ZKN	■ ■ ■ ■	1154.74	1183.64	1349.69	1418.22	1712.82	1798.55
				7,8,9	QBDF-2372-ZKN	■ ■ ■ ■	1165.46	1194.36	1360.41	1428.94	1723.54	1809.27
6" Open/12"H Hinged Door Open — Right	23"(584mm)	47 7/8"(1216mm)	48"(1219mm)	2,3	QBDF-2348-KZN	■ ■ ■ ■	\$1030.50	\$1050.84	\$1186.89	\$1242.58	\$1472.90	\$1537.19
				7,8,9	QBDF-2348-KZN	■ ■ ■ ■	1041.22	1061.56	1197.61	1253.30	1483.62	1547.91
	59 7/8"(1521mm)	60"(1524mm)		1	QBDF-2360-KZN	■ ■ ■ ■	\$1039.06	\$1063.68	\$1214.73	\$1276.84	\$1539.30	\$1614.31
				2,3	QBDF-2360-KZN	■ ■ ■ ■	1092.62	1117.24	1268.29	1330.40	1592.86	1667.87
				7,8,9	QBDF-2360-KZN	■ ■ ■ ■	1103.34	1127.96	1279.01	1341.12	1603.58	1678.59
	71 7/8"(1826mm)	72"(1829mm)		1	QBDF-2372-KZN	■ ■ ■ ■	\$1101.18	\$1130.08	\$1296.13	\$1364.66	\$1659.26	\$1744.99
				2,3	QBDF-2372-KZN	■ ■ ■ ■	1154.74	1183.64	1349.69	1418.22	1712.82	1798.55
				7,8,9	QBDF-2372-KZN	■ ■ ■ ■	1165.46	1194.36	1360.41	1428.94	1723.54	1809.27

*Finished Height includes worksurface top, spacer, base unit and legs

Base Unit — Hinged Door and Open Storage Unit

Description	Finished Height*	Actual Width	Nominal Width	Pull	Number	Case Laminate A				Wood Door Group A	Wood Door Group B				
						Steel Door Trim A	Steel Door Trim B	Laminate Door A	Laminate Door B						
Double — 2H															
Open — Left 12" Open/12"H Hinged Door	29"(737mm)	47 7/8"(1216mm)	48"(1219mm)	2,3	QBDF-2948-ZKN	■	■	■	■	\$1164.40	\$1189.03	\$1331.50	\$1387.19	\$1638.93	\$1703.22
				7,8,9	QBDF-2948-ZKN	■	■	■	■	1175.12	1199.75	1342.22	1397.91	1649.65	1713.94
	59 7/8"(1521mm)	60"(1524mm)		1	QBDF-2960-ZKN	■	■	■	■	\$1179.40	\$1208.31	\$1365.78	\$1427.89	\$1711.77	\$1786.78
				2,3	QBDF-2960-ZKN	■	■	■	■	1232.96	1261.87	1419.34	1481.45	1765.33	1840.34
				7,8,9	QBDF-2960-ZKN	■	■	■	■	1243.68	1272.59	1430.06	1492.17	1776.05	1851.06
	71 7/8"(1826mm)	72"(1829mm)		1	QBDF-2972-ZKN	■	■	■	■	\$1247.96	\$1281.15	\$1453.62	\$1522.15	\$1838.17	\$1923.90
				2,3	QBDF-2972-ZKN	■	■	■	■	1301.52	1334.71	1507.18	1575.71	1891.73	1977.46
				7,8,9	QBDF-2972-ZKN	■	■	■	■	1312.24	1345.43	1517.90	1586.43	1902.45	1988.18
12" Open/12"H Hinged Door Open — Right	29"(737mm)	47 7/8"(1216mm)	48"(1219mm)	2,3	QBDF-2948-KZN	■	■	■	■	\$1164.40	\$1189.03	\$1331.50	\$1387.19	\$1638.93	\$1703.22
				7,8,9	QBDF-2948-KZN	■	■	■	■	1175.12	1199.75	1342.22	1397.91	1649.65	1713.94
	59 7/8"(1521mm)	60"(1524mm)		1	QBDF-2960-KZN	■	■	■	■	\$1179.40	\$1208.31	\$1365.78	\$1427.89	\$1711.77	\$1786.78
				2,3	QBDF-2960-KZN	■	■	■	■	1232.96	1261.87	1419.34	1481.45	1765.33	1840.34
				7,8,9	QBDF-2960-KZN	■	■	■	■	1243.68	1272.59	1430.06	1492.17	1776.05	1851.06
	71 7/8"(1826mm)	72"(1829mm)		1	QBDF-2972-KZN	■	■	■	■	\$1247.96	\$1281.15	\$1453.62	\$1522.15	\$1838.17	\$1923.90
				2,3	QBDF-2972-KZN	■	■	■	■	1301.52	1334.71	1507.18	1575.71	1891.73	1977.46
				7,8,9	QBDF-2972-KZN	■	■	■	■	1312.24	1345.43	1517.90	1586.43	1902.45	1988.18
Open — Left 6" Open/18"H Hinged Door	29"(737mm)	47 7/8"(1216mm)	48"(1219mm)	2,3	QBDF-2948-ZLN	■	■	■	■	\$1164.40	\$1189.03	\$1331.50	\$1387.19	\$1638.93	\$1703.22
				7,8,9	QBDF-2948-ZLN	■	■	■	■	1175.12	1199.75	1342.22	1397.91	1649.65	1713.94
	59 7/8"(1521mm)	60"(1524mm)		1	QBDF-2960-ZLN	■	■	■	■	\$1179.40	\$1208.31	\$1365.78	\$1427.89	\$1711.77	\$1786.78
				2,3	QBDF-2960-ZLN	■	■	■	■	1232.96	1261.87	1419.34	1481.45	1765.33	1840.34
				7,8,9	QBDF-2960-ZLN	■	■	■	■	1243.68	1272.59	1430.06	1492.17	1776.05	1851.06
	71 7/8"(1826mm)	72"(1829mm)		1	QBDF-2972-ZLN	■	■	■	■	\$1247.96	\$1281.15	\$1453.62	\$1522.15	\$1838.17	\$1923.90
				2,3	QBDF-2972-ZLN	■	■	■	■	1301.52	1334.71	1507.18	1575.71	1891.73	1977.46
				7,8,9	QBDF-2972-ZLN	■	■	■	■	1312.24	1345.43	1517.90	1586.43	1902.45	1988.18
6" Open/18"H Hinged Door Open — Right	29"(737mm)	47 7/8"(1216mm)	48"(1219mm)	2,3	QBDF-2948-LZN	■	■	■	■	\$1164.40	\$1189.03	\$1331.50	\$1387.19	\$1638.93	\$1703.22
				7,8,9	QBDF-2948-LZN	■	■	■	■	1175.12	1199.75	1342.22	1397.91	1649.65	1713.94
	59 7/8"(1521mm)	60"(1524mm)		1	QBDF-2960-LZN	■	■	■	■	\$1179.40	\$1208.31	\$1365.78	\$1427.89	\$1711.77	\$1786.78
				2,3	QBDF-2960-LZN	■	■	■	■	1232.96	1261.87	1419.34	1481.45	1765.33	1840.34
				7,8,9	QBDF-2960-LZN	■	■	■	■	1243.68	1272.59	1430.06	1492.17	1776.05	1851.06
	71 7/8"(1826mm)	72"(1829mm)		1	QBDF-2972-LZN	■	■	■	■	\$1247.96	\$1281.15	\$1453.62	\$1522.15	\$1838.17	\$1923.90
				2,3	QBDF-2972-LZN	■	■	■	■	1301.52	1334.71	1507.18	1575.71	1891.73	1977.46
				7,8,9	QBDF-2972-LZN	■	■	■	■	1312.24	1345.43	1517.90	1586.43	1902.45	1988.18

*Finished Height includes worksurface top, spacer, base unit and legs

Base Unit — Hinged Door and Open Storage Unit

Description	Finished Height*	Actual Width	Nominal Width	Pull	Number	Case Laminate B				Wood Door		
						Steel Door Trim A	Trim B	Laminate Door A	Door B	Group A	Group B	
Single — 1.5H												
6" Open/12"H Hinged Door	23"(584mm)	23 7/8"(606mm)	24"(610mm)	2,3	QBSF-2324-KNN	■ ■ ■ ■	\$ 882.67	\$ 894.45	\$1000.50	\$1043.35	\$1209.39	\$1252.24
				7,8,9	QBSF-2324-KNN	■ ■ ■ ■	893.39	905.17	1011.22	1054.07	1220.11	1262.96
	29 7/8"(759mm)	30"(762mm)		1	QBSF-2330-KNN	■ ■ ■ ■	\$ 886.95	\$ 900.87	\$1014.42	\$1060.48	\$1242.59	\$1290.80
				2,3	QBSF-2330-KNN	■ ■ ■ ■	940.51	954.43	1067.98	1114.04	1296.15	1344.36
				7,8,9	QBSF-2330-KNN	■ ■ ■ ■	951.23	965.15	1078.70	1124.76	1306.87	1355.08
	35 7/8"(911mm)	36"(914mm)		1	QBSF-2336-KNN	■ ■ ■ ■	\$ 944.79	\$ 960.85	\$1081.90	\$1131.17	\$1329.35	\$1382.92
				2,3	QBSF-2336-KNN	■ ■ ■ ■	998.35	1014.41	1135.46	1184.73	1382.91	1436.48
				7,8,9	QBSF-2336-KNN	■ ■ ■ ■	1009.07	1025.13	1146.18	1195.45	1393.63	1447.20
	41 7/8"(1064mm)	42"(1067mm)		1	QBSF-2342-KNN	■ ■ ■ ■	\$1002.63	\$1020.83	\$1149.38	\$1201.86	\$1416.11	\$1475.04
				2,3	QBSF-2342-KNN	■ ■ ■ ■	1056.19	1074.39	1202.94	1255.42	1469.67	1528.60
				7,8,9	QBSF-2342-KNN	■ ■ ■ ■	1066.91	1085.11	1213.66	1266.14	1480.39	1539.32
Single — 2H												
6" Open/18"H Hinged Door	29"(737mm)	23 7/8"(606mm)	24"(610mm)	2,3	QBSF-2924-LNN	■ ■ ■ ■	\$ 991.94	\$1008.01	\$1120.48	\$1163.33	\$1350.79	\$1393.64
				7,8,9	QBSF-2924-LNN	■ ■ ■ ■	1002.66	1018.73	1131.20	1174.05	1361.51	1404.36
	29 7/8"(759mm)	30"(762mm)		1	QBSF-2930-LNN	■ ■ ■ ■	\$ 988.72	\$1006.93	\$1126.90	\$1172.96	\$1376.49	\$1424.70
				2,3	QBSF-2930-LNN	■ ■ ■ ■	1042.28	1060.49	1180.46	1226.52	1430.05	1478.26
				7,8,9	QBSF-2930-LNN	■ ■ ■ ■	1053.00	1071.21	1191.18	1237.24	1440.77	1488.98
	35 7/8"(911mm)	36"(914mm)		1	QBSF-2936-LNN	■ ■ ■ ■	\$1039.06	\$1059.41	\$1186.88	\$1236.15	\$1455.75	\$1509.32
				2,3	QBSF-2936-LNN	■ ■ ■ ■	1092.62	1112.97	1240.44	1289.71	1509.31	1562.88
				7,8,9	QBSF-2936-LNN	■ ■ ■ ■	1103.34	1123.69	1251.16	1300.43	1520.03	1573.60
	41 7/8"(1064mm)	42"(1067mm)		1	QBSF-2942-LNN	■ ■ ■ ■	\$1089.40	\$1111.89	\$1246.86	\$1299.34	\$1535.01	\$1593.94
				2,3	QBSF-2942-LNN	■ ■ ■ ■	1142.96	1165.45	1300.42	1352.90	1588.57	1647.50
				7,8,9	QBSF-2942-LNN	■ ■ ■ ■	1153.68	1176.17	1311.14	1363.62	1599.29	1658.22
12" Open/12"H Hinged Door	29"(737mm)	23 7/8"(606mm)	24"(610mm)	2,3	QBSF-2924-KNN	■ ■ ■ ■	\$ 991.94	\$1008.01	\$1120.48	\$1163.33	\$1350.79	\$1393.64
				7,8,9	QBSF-2924-KNN	■ ■ ■ ■	1002.66	1018.73	1131.20	1174.05	1361.51	1404.36
	29 7/8"(759mm)	30"(762mm)		1	QBSF-2930-KNN	■ ■ ■ ■	\$ 988.72	\$1006.93	\$1126.90	\$1172.96	\$1376.49	\$1424.70
				2,3	QBSF-2930-KNN	■ ■ ■ ■	1042.28	1060.49	1180.46	1226.52	1430.05	1478.26
				7,8,9	QBSF-2930-KNN	■ ■ ■ ■	1053.00	1071.21	1191.18	1237.24	1440.77	1488.98
	35 7/8"(911mm)	36"(914mm)		1	QBSF-2936-KNN	■ ■ ■ ■	\$1039.06	\$1059.41	\$1186.88	\$1236.15	\$1455.75	\$1509.32
				2,3	QBSF-2936-KNN	■ ■ ■ ■	1092.62	1112.97	1240.44	1289.71	1509.31	1562.88
				7,8,9	QBSF-2936-KNN	■ ■ ■ ■	1103.34	1123.69	1251.16	1300.43	1520.03	1573.60
	41 7/8"(1064mm)	42"(1067mm)		1	QBSF-2942-KNN	■ ■ ■ ■	\$1089.40	\$1111.89	\$1246.86	\$1299.34	\$1535.01	\$1593.94
				2,3	QBSF-2942-KNN	■ ■ ■ ■	1142.96	1165.45	1300.42	1352.90	1588.57	1647.50
				7,8,9	QBSF-2942-KNN	■ ■ ■ ■	1153.68	1176.17	1311.14	1363.62	1599.29	1658.22
Double — 1.5H												
Open — Left 6" Open/12"H Hinged Door	23"(584mm)	47 7/8"(1216mm)	48"(1219mm)	2,3	QBDF-2348-ZKN	■ ■ ■ ■	\$1087.26	\$1107.60	\$1243.65	\$1299.34	\$1529.66	\$1593.95
				7,8,9	QBDF-2348-ZKN	■ ■ ■ ■	1097.98	1118.32	1254.37	1310.06	1540.38	1604.67
	59 7/8"(1521mm)	60"(1524mm)		1	QBDF-2360-ZKN	■ ■ ■ ■	\$1100.10	\$1124.72	\$1275.77	\$1337.88	\$1600.34	\$1675.35
				2,3	QBDF-2360-ZKN	■ ■ ■ ■	1153.66	1178.28	1329.33	1391.44	1653.90	1728.91
				7,8,9	QBDF-2360-ZKN	■ ■ ■ ■	1164.38	1189.00	1340.05	1402.16	1664.62	1739.63
	71 7/8"(1826mm)	72"(1829mm)		1	QBDF-2372-ZKN	■ ■ ■ ■	\$1166.50	\$1195.40	\$1361.45	\$1429.98	\$1724.58	\$1810.31
				2,3	QBDF-2372-ZKN	■ ■ ■ ■	1220.06	1248.96	1415.01	1483.54	1778.14	1863.87
				7,8,9	QBDF-2372-ZKN	■ ■ ■ ■	1230.78	1259.68	1425.73	1494.26	1788.86	1874.59
6" Open/12"H Hinged Door Open — Right	23"(584mm)	47 7/8"(1216mm)	48"(1219mm)	2,3	QBDF-2348-KZN	■ ■ ■ ■	\$1087.26	\$1107.60	\$1243.65	\$1299.34	\$1529.66	\$1593.95
				7,8,9	QBDF-2348-KZN	■ ■ ■ ■	1097.98	1118.32	1254.37	1310.06	1540.38	1604.67
	59 7/8"(1521mm)	60"(1524mm)		1	QBDF-2360-KZN	■ ■ ■ ■	\$1100.10	\$1124.72	\$1275.77	\$1337.88	\$1600.34	\$1675.35
				2,3	QBDF-2360-KZN	■ ■ ■ ■	1153.66	1178.28	1329.33	1391.44	1653.90	1728.91
				7,8,9	QBDF-2360-KZN	■ ■ ■ ■	1164.38	1189.00	1340.05	1402.16	1664.62	1739.63
	71 7/8"(1826mm)	72"(1829mm)		1	QBDF-2372-KZN	■ ■ ■ ■	\$1166.50	\$1195.40	\$1361.45	\$1429.98	\$1724.58	\$1810.31
				2,3	QBDF-2372-KZN	■ ■ ■ ■	1220.06	1248.96	1415.01	1483.54	1778.14	1863.87
				7,8,9	QBDF-2372-KZN	■ ■ ■ ■	1230.78	1259.68	1425.73	1494.26	1788.86	1874.59

*Finished Height includes worksurface top, spacer, base unit and legs

Base Unit — Hinged Door and Open Storage Unit

Description	Finished Height*	Actual Width	Nominal Width	Pull	Number	Case Laminate B				Wood Door					
						Steel Door Trim A	Steel Door Trim B	Laminate Door A	Laminate Door B	Group A	Group B				
Double — 2H															
Open — Left 12" Open/12"H Hinged Door	29"(737mm)	47 7/8"(1216mm)	48"(1219mm)	2,3	QBDF-2948-ZKN	■	■	■	■	\$1227.59	\$1252.22	\$1394.69	\$1450.38	\$1702.12	\$1766.41
				7,8,9	QBDF-2948-ZKN	■	■	■	■	1238.31	1262.94	1405.41	1461.10	1712.84	1777.13
	59 7/8"(1521mm)	60"(1524mm)		1	QBDF-2960-ZKN	■	■	■	■	\$1246.87	\$1275.78	\$1433.25	\$1495.36	\$1779.24	\$1854.25
				2,3	QBDF-2960-ZKN	■	■	■	■	1300.43	1329.34	1486.81	1548.92	1832.80	1907.81
				7,8,9	QBDF-2960-ZKN	■	■	■	■	1311.15	1340.06	1497.53	1559.64	1843.52	1918.53
	71 7/8"(1826mm)	72"(1829mm)		1	QBDF-2972-ZKN	■	■	■	■	\$1319.71	\$1352.90	\$1525.37	\$1593.90	\$1909.92	\$1995.65
				2,3	QBDF-2972-ZKN	■	■	■	■	1373.27	1406.46	1578.93	1647.46	1963.48	2049.21
				7,8,9	QBDF-2972-ZKN	■	■	■	■	1383.99	1417.18	1589.65	1658.18	1974.20	2059.93
12" Open/12"H Hinged Door Open — Right	29"(737mm)	47 7/8"(1216mm)	48"(1219mm)	2,3	QBDF-2948-KZN	■	■	■	■	\$1227.59	\$1252.22	\$1394.69	\$1450.38	\$1702.12	\$1766.41
				7,8,9	QBDF-2948-KZN	■	■	■	■	1238.31	1262.94	1405.41	1461.10	1712.84	1777.13
	59 7/8"(1521mm)	60"(1524mm)		1	QBDF-2960-KZN	■	■	■	■	\$1246.87	\$1275.78	\$1433.25	\$1495.36	\$1779.24	\$1854.25
				2,3	QBDF-2960-KZN	■	■	■	■	1300.43	1329.34	1486.81	1548.92	1832.80	1907.81
				7,8,9	QBDF-2960-KZN	■	■	■	■	1311.15	1340.06	1497.53	1559.64	1843.52	1918.53
	71 7/8"(1826mm)	72"(1829mm)		1	QBDF-2972-KZN	■	■	■	■	\$1319.71	\$1352.90	\$1525.37	\$1593.90	\$1909.92	\$1995.65
				2,3	QBDF-2972-KZN	■	■	■	■	1373.27	1406.46	1578.93	1647.46	1963.48	2049.21
				7,8,9	QBDF-2972-KZN	■	■	■	■	1383.99	1417.18	1589.65	1658.18	1974.20	2059.93
Open — Left 6" Open/18"H Hinged Door	29"(737mm)	47 7/8"(1216mm)	48"(1219mm)	2,3	QBDF-2948-ZLN	■	■	■	■	\$1227.59	\$1252.22	\$1394.69	\$1450.38	\$1702.12	\$1766.41
				7,8,9	QBDF-2948-ZLN	■	■	■	■	1238.31	1262.94	1405.41	1461.10	1712.84	1777.13
	59 7/8"(1521mm)	60"(1524mm)		1	QBDF-2960-ZLN	■	■	■	■	\$1246.87	\$1275.78	\$1433.25	\$1495.36	\$1779.24	\$1854.25
				2,3	QBDF-2960-ZLN	■	■	■	■	1300.43	1329.34	1486.81	1548.92	1832.80	1907.81
				7,8,9	QBDF-2960-ZLN	■	■	■	■	1311.15	1340.06	1497.53	1559.64	1843.52	1918.53
	71 7/8"(1826mm)	72"(1829mm)		1	QBDF-2972-ZLN	■	■	■	■	\$1319.71	\$1352.90	\$1525.37	\$1593.90	\$1909.92	\$1995.65
				2,3	QBDF-2972-ZLN	■	■	■	■	1373.27	1406.46	1578.93	1647.46	1963.48	2049.21
				7,8,9	QBDF-2972-ZLN	■	■	■	■	1383.99	1417.18	1589.65	1658.18	1974.20	2059.93
6" Open/18"H Hinged Door Open — Right	29"(737mm)	47 7/8"(1216mm)	48"(1219mm)	2,3	QBDF-2948-LZN	■	■	■	■	\$1227.59	\$1252.22	\$1394.69	\$1450.38	\$1702.12	\$1766.41
				7,8,9	QBDF-2948-LZN	■	■	■	■	1238.31	1262.94	1405.41	1461.10	1712.84	1777.13
	59 7/8"(1521mm)	60"(1524mm)		1	QBDF-2960-LZN	■	■	■	■	\$1246.87	\$1275.78	\$1433.25	\$1495.36	\$1779.24	\$1854.25
				2,3	QBDF-2960-LZN	■	■	■	■	1300.43	1329.34	1486.81	1548.92	1832.80	1907.81
				7,8,9	QBDF-2960-LZN	■	■	■	■	1311.15	1340.06	1497.53	1559.64	1843.52	1918.53
	71 7/8"(1826mm)	72"(1829mm)		1	QBDF-2972-LZN	■	■	■	■	\$1319.71	\$1352.90	\$1525.37	\$1593.90	\$1909.92	\$1995.65
				2,3	QBDF-2972-LZN	■	■	■	■	1373.27	1406.46	1578.93	1647.46	1963.48	2049.21
				7,8,9	QBDF-2972-LZN	■	■	■	■	1383.99	1417.18	1589.65	1658.18	1974.20	2059.93

*Finished Height includes worksurface top, spacer, base unit and legs

This page intentionally blank

Base Unit — Hinged Door and Drawer Combination

Hinged Door — Drawer Combination

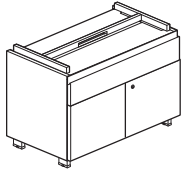

QBSF

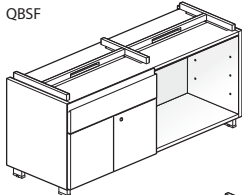

QBDF

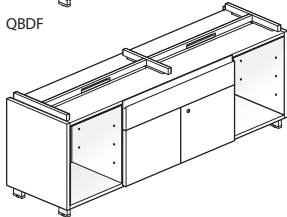

QBTF

2 Pull Styles



Ellipse (1)



Crescent (7)



Radius (2)



Linear (8)



Taper (3)



Classic (9)

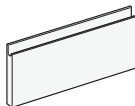

J-Pull (J)

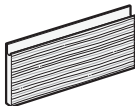

J-Pull (K)

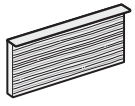

Blade Pull (Q)

Touch Latch Only (N)
(add \$26.00 list)

2 Pull Styles with Touch Latch Door



Ellipse (A)



Crescent (D)



Radius (B)



Linear (E)



Taper (C)



Classic (F)

Features

- Hinged Door Single Base Unit include:
 - Laminate case standard with a painted steel inset back and base.
 - Full access hinges that open 100 degrees.
 - If specified right-hand door includes touch latch mechanism (free swing hinge).
 - If specified left-hand door includes full length return flange (self-closing hinge).
 - Leg and drawer options.
 - Spacer
- Ellipse pull available in non-metallic color only. (see finish page for pull color)
- Radius pull available in metallic colors only. (see finish page for pull color)
- J-Pull (J) matches painted steel fronts.
- J-Pull (K) and Blade Pull (Q) available on laminate or wood fronts only. Must specify color.
- Leg Options:
 - Straight Leg (F); requires trim color.
 - Chamfer Leg (P); requires trim color.
- Glide adjustment range:
 - Straight Leg: 1.5”(38mm)
 - Chamfer Leg: 1.25”(32mm)
- Spacer:
 - 1.18”(30mm) high
 - End pieces come in specified color; center spacer section black only.
- Door front options include painted, laminate or wood.
- Lock plugs:
 - Locking (chrome only) and non-locking available.
 - Single and double base units have one lock.
 - Triple base units may have more than one lock.
- Shelves are separately specified; not included with unit.
- Case ships assembled. Legs require field installation.

Specification Tips

- Designed to be used with Haworth's Integrated Palette, UniGroup Too, PREMISE, Reside Desking and/or Belong Work Tools.
- Beside base units 24”-42”(610mm-1067mm) cannot be freestanding. Units must be attached or ganged together. All base units with drawers must be attached. Refer to Specification Guide for planning information.
- Beside base units 48”-72”(1219mm-1829mm) widths can be freestanding.
- Separately specified storage tops are required and can match the width of a single base unit or span two or more adjacent base units side by side.
- To route and access power in storage, order separately specified Belong power components.
- 1.5H and 2H storage can be used to support Reside desking or Adaptable worksurface in a perpendicular configuration with separately specified brackets. Refer to Specification Guide for planning information.
- Beside base storage unit with top, spacer, base unit and legs finished heights:
 - 1H = 17”(432mm)
 - 1.5H = 23”(584mm)
 - 2H = 29”(737mm)
- Separately specified if applicable:
 - Belong Power and communication cabling, tools, screens and tool rails.
 - Storage-to-Panel Bracket
 - Storage Attachment Bracket
 - Ganging Bracket
 - Storage Top (required)
 - Filler Panel
 - Top Filler Track
 - Finished Back (recommended when back is exposed)
 - Adjustable Shelf (not included with unit)
 - Stack-On Hutch
- Refer to Specification Guide for planning information and actual dimensions.

Notes: 2H storage base units are not designed to fit under Reside benching or return worksurfaces. Reside Desking or Adaptable worksurfaces can be attached to the front or back of a 2H Beside storage unit with separately specified flush mount plates.

Separately specified Belong base unit power components available for 30”-72”(372mm-1829mm) widths.

Storage shelves are unique to the specific base unit configuration. Refer to shelf price list pages for appropriate shelf.

1H units cannot accept binders.

To Order, Specify:

Steel Door/Drawer Front

1) Product number, including:

1 Door/Drawer Front Option:

S Steel

2 Pull Option: (see side bar)

3 Leg Option:

F Straight Leg

P Chamfer Leg, add \$85.70 list

4 Lock Option:

L Locking, add \$42.85 list

N Non-Locking

2) Case laminate color.

3) Case laminate edgeband color.

4) Bottom, inset back and fixed shelf trim color.

5) Pull, leg and spacer trim color.

6) Door front color.

Laminate or Wood Door/Drawer Front

1) Product number, including:

1 Door/Drawer Front Option:

L Laminate

W Wood

2 Pull Option: (see side bar)

3 Leg Option:

F Straight Leg

P Chamfer Leg, add \$85.70 list

4 Lock Option:

L Locking, add \$42.85 list

N Non-Locking

2) Case laminate color.

3) Case laminate edgeband color.

4) Bottom, inset back and fixed shelf trim color.

5) Pull, leg and spacer trim color.

6) Door front color.

7) Laminate front edgeband color.

Note: Upcharge for mixed grade fabric or trim surfaces, refer to the electronic design and specification tools for pricing.

Base Unit — Hinged Door and Drawer Combination

Description	Finished Height*	Actual Width	Nominal Width	Pull	Number	Case Laminate A				Steel Door Trim A	Steel Door Trim B	Laminate Door		Wood Door	
						①	②	③	④			A	B	Group A	Group B
Single — 1.5H															
Box Drawer/12"H Hinged Door	23"(584mm)	23 7/8"(606mm)	24"(610mm)	J	QBSF-2324-MNN	J				\$ 945.87	\$ 957.65	N/A	N/A	N/A	N/A
					2,3	QBSF-2324-MNN				998.36	1010.14	1116.19	1159.04	1325.08	1367.93
					7,8,9	QBSF-2324-MNN				1014.44	1026.22	1132.27	1175.12	1341.16	1384.01
					K	QBSF-2324-MNN	K			N/A	N/A	1256.51	1299.36	1465.40	1508.25
					Q	QBSF-2324-MNN	Q			N/A	N/A	1352.93	1395.78	1561.82	1604.67
	29 7/8"(759mm)	30"(762mm)			1,J	QBSF-2330-MNN				\$ 971.58	\$ 985.50	\$1099.05	\$1145.11	\$1327.22	\$1375.43
					2,3	QBSF-2330-MNN				1051.92	1065.84	1179.39	1225.45	1407.56	1455.77
					7,8,9	QBSF-2330-MNN				1068.00	1081.92	1195.47	1241.53	1423.64	1471.85
					K	QBSF-2330-MNN	K			N/A	N/A	1319.71	1365.77	1547.88	1596.09
					Q	QBSF-2330-MNN	Q			N/A	N/A	1416.13	1462.19	1644.30	1692.51
	35 7/8"(911mm)	36"(914mm)			1,J	QBSF-2336-MNN				\$1025.14	\$1041.20	\$1162.25	\$1211.52	\$1409.70	\$1463.27
					2,3	QBSF-2336-MNN				1105.48	1121.54	1242.59	1291.86	1490.04	1543.61
					7,8,9	QBSF-2336-MNN				1121.56	1137.62	1258.67	1307.94	1506.12	1559.69
					K	QBSF-2336-MNN	K			N/A	N/A	1382.91	1432.18	1630.36	1683.93
					Q	QBSF-2336-MNN	Q			N/A	N/A	1479.33	1528.60	1726.78	1780.35
Single — 2H															
Box Drawer/18"H Hinged Door	29"(737mm)	23 7/8"(606mm)	24"(610mm)	J	QBSF-2924-ONN	J				\$1097.99	\$1114.06	N/A	N/A	N/A	N/A
					2,3	QBSF-2924-ONN				1150.48	1166.55	1279.02	1321.87	1509.33	1552.18
					7,8,9	QBSF-2924-ONN				1166.56	1182.63	1295.10	1337.95	1525.41	1568.26
					K	QBSF-2924-ONN	K			N/A	N/A	1419.34	1462.19	1649.65	1692.50
					Q	QBSF-2924-ONN	Q			N/A	N/A	1515.76	1558.61	1746.07	1788.92
	29 7/8"(759mm)	30"(762mm)			1,J	QBSF-2930-ONN				\$1132.27	\$1150.48	\$1270.45	\$1316.51	\$1520.04	\$1568.25
					2,3	QBSF-2930-ONN				1212.61	1230.82	1350.79	1396.85	1600.38	1648.59
					7,8,9	QBSF-2930-ONN				1228.69	1246.90	1366.87	1412.93	1616.46	1664.67
					K	QBSF-2930-ONN	K			N/A	N/A	1491.11	1537.17	1740.70	1788.91
					Q	QBSF-2930-ONN	Q			N/A	N/A	1587.53	1633.59	1837.12	1885.33
	35 7/8"(911mm)	36"(914mm)			1,J	QBSF-2936-ONN				\$1194.40	\$1214.75	\$1342.22	\$1391.49	\$1611.09	\$1664.66
					2,3	QBSF-2936-ONN				1274.74	1295.09	1422.56	1471.83	1691.43	1745.00
					7,8,9	QBSF-2936-ONN				1290.82	1311.17	1438.64	1487.91	1707.51	1761.08
					K	QBSF-2936-ONN	K			N/A	N/A	1562.88	1612.15	1831.75	1885.32
					Q	QBSF-2936-ONN	Q			N/A	N/A	1659.30	1708.57	1928.17	1981.74
Double — 1.5H															
Open — Left Box Drawer/12"H Hinged Door	23"(584mm)	47 7/8"(1216mm)	48"(1219mm)	J	QBDF-2348-ZMN	J				\$1219.03	\$1239.37	N/A	N/A	N/A	N/A
					2,3	QBDF-2348-ZMN				1271.52	1291.86	1427.91	1483.60	1713.92	1778.21
					7,8,9	QBDF-2348-ZMN				1287.60	1307.94	1443.99	1499.68	1730.00	1794.29
					K	QBDF-2348-ZMN	K			N/A	N/A	1568.23	1623.92	1854.24	1918.53
					Q	QBDF-2348-ZMN	Q			N/A	N/A	1664.65	1720.34	1950.66	2014.95
	59 7/8"(1521mm)	60"(1524mm)			1,J	QBDF-2360-ZMN				\$1287.58	\$1312.20	\$1463.25	\$1525.36	\$1787.82	\$1862.83
					2,3	QBDF-2360-ZMN				1367.92	1392.54	1543.59	1605.70	1868.16	1943.17
					7,8,9	QBDF-2360-ZMN				1384.00	1408.62	1559.67	1621.78	1884.24	1959.25
					K	QBDF-2360-ZMN	K			N/A	N/A	1683.91	1746.02	2008.48	2083.49
					Q	QBDF-2360-ZMN	Q			N/A	N/A	1780.33	1842.44	2104.90	2179.91
	71 7/8"(1826mm)	72"(1829mm)			1,J	QBDF-2372-ZMN				\$1383.98	\$1412.88	\$1578.93	\$1647.46	\$1942.06	\$2027.79
					2,3	QBDF-2372-ZMN				1464.32	1493.22	1659.27	1727.80	2022.40	2108.13
					7,8,9	QBDF-2372-ZMN				1480.40	1509.30	1675.35	1743.88	2038.48	2124.21
					K	QBDF-2372-ZMN	K			N/A	N/A	1799.59	1868.12	2162.72	2248.45
					Q	QBDF-2372-ZMN	Q			N/A	N/A	1868.16	1936.69	2259.14	2344.87
Box Drawer/12"H Hinged Door Open — Right	23"(584mm)	47 7/8"(1216mm)	48"(1219mm)	J	QBDF-2348-MZN	J				\$1219.03	\$1239.37	N/A	N/A	N/A	N/A
					2,3	QBDF-2348-MZN				1271.52	1291.86	1427.91	1483.60	1713.92	1778.21
					7,8,9	QBDF-2348-MZN				1287.60	1307.94	1443.99	1499.68	1730.00	1794.29
					K	QBDF-2348-MZN	K			N/A	N/A	1568.23	1623.92	1854.24	1918.53
					Q	QBDF-2348-MZN	Q			N/A	N/A	1664.65	1720.34	1950.66	2014.95
	59 7/8"(1521mm)	60"(1524mm)			1,J	QBDF-2360-MZN				\$1287.58	\$1312.20	\$1463.25	\$1525.36	\$1787.82	\$1862.83
					2,3	QBDF-2360-MZN				1367.92	1392.54	1543.59	1605.70	1868.16	1943.17
					7,8,9	QBDF-2360-MZN				1384.00	1408.62	1559.67	1621.78	1884.24	1959.25
					K	QBDF-2360-MZN	K			N/A	N/A	1683.91	1746.02	2008.48	2083.49
					Q	QBDF-2360-MZN	Q			N/A	N/A	1780.33	1842.44	2104.90	2179.91
	71 7/8"(1826mm)	72"(1829mm)			1,J	QBDF-2372-MZN				\$1383.98	\$1412.88	\$1578.93	\$1647.46	\$1942.06	\$2027.79
					2,3	QBDF-2372-MZN				1464.32	1493.22	1659.27	1727.80	2022.40	2108.13
					7,8,9	QBDF-2372-MZN				1480.40	1509.30	1675.35	1743.88	2038.48	2124.21
					K	QBDF-2372-MZN	K			N/A	N/A	1799.59	1868.12	2162.72	2248.45
					Q	QBDF-2372-MZN	Q			N/A	N/A	1896.01	1964.54	2259.14	2344.87

Base Unit — Hinged Door and Drawer Combination

Description	Finished Height*	Actual Width	Nominal Width	Pull	Number	Case Laminate A				Wood Door					
						Steel Door Trim A	Steel Door Trim B	Laminate Door A	Laminate Door B	Group A	Group B				
Double — 2H															
Open — Left Box Drawer/18"H Hinged Door	29"(737mm)	47 7/8"(1216mm)	48"(1219mm)	J	QBDF-2948-ZON	J				\$1510.39	\$1535.02	N/A	N/A	N/A	N/A
					2,3	QBDF-2948-ZON				1562.88	1587.51	1729.98	1785.67	2037.41	2101.70
					7,8,9	QBDF-2948-ZON				1578.96	1603.59	1746.06	1801.75	2053.49	2117.78
					K	QBDF-2948-ZON	K			N/A	N/A	1870.30	1925.99	2177.73	2242.02
					Q	QBDF-2948-ZON	Q			N/A	N/A	1966.72	2022.41	2274.15	2338.44
	59 7/8"(1521mm)	60"(1524mm)			1,J	QBDF-2960-ZON				\$1585.38	\$1614.29	\$1771.76	\$1833.87	\$2117.75	\$2192.76
					2,3	QBDF-2960-ZON				1665.72	1694.63	1852.10	1914.21	2198.09	2273.10
					7,8,9	QBDF-2960-ZON				1681.80	1710.71	1868.18	1930.29	2214.17	2289.18
					K	QBDF-2960-ZON	K			N/A	N/A	1992.42	2054.53	2338.41	2413.42
					Q	QBDF-2960-ZON	Q			N/A	N/A	2088.84	2150.95	2434.83	2509.84
	71 7/8"(1826mm)	72"(1829mm)			1,J	QBDF-2972-ZON				\$1688.22	\$1721.41	\$1893.88	\$1962.41	\$2278.43	\$2364.16
					2,3	QBDF-2972-ZON				1768.56	1801.75	1974.22	2042.75	2358.77	2444.50
					7,8,9	QBDF-2972-ZON				1784.64	1817.83	1990.30	2058.83	2374.85	2460.58
					K	QBDF-2972-ZON	K			N/A	N/A	2114.54	2183.07	2499.09	2584.82
					Q	QBDF-2972-ZON	Q			N/A	N/A	2210.96	2279.49	2595.51	2681.24
Box Drawer/18"H Hinged Door Open — Right	29"(737mm)	47 7/8"(1216mm)	48"(1219mm)	J	QBDF-2948-OZN	J				\$1510.39	\$1535.02	N/A	N/A	N/A	N/A
					2,3	QBDF-2948-OZN				1562.88	1587.51	1729.98	1785.67	2037.41	2101.70
					7,8,9	QBDF-2948-OZN				1578.96	1603.59	1746.06	1801.75	2053.49	2117.78
					K	QBDF-2948-OZN	K			N/A	N/A	1870.30	1925.99	2177.73	2242.02
					Q	QBDF-2948-OZN	Q			N/A	N/A	1966.72	2022.41	2274.15	2338.44
	59 7/8"(1521mm)	60"(1524mm)			1,J	QBDF-2960-OZN				\$1585.38	\$1614.29	\$1771.76	\$1833.87	\$2117.75	\$2192.76
					2,3	QBDF-2960-OZN				1665.72	1694.63	1852.10	1914.21	2198.09	2273.10
					7,8,9	QBDF-2960-OZN				1681.80	1710.71	1868.18	1930.29	2214.17	2289.18
					K	QBDF-2960-OZN	K			N/A	N/A	1992.42	2054.53	2338.41	2413.42
					Q	QBDF-2960-OZN	Q			N/A	N/A	2088.84	2150.95	2434.83	2509.84
	71 7/8"(1826mm)	72"(1829mm)			1,J	QBDF-2972-OZN				\$1688.22	\$1721.41	\$1893.88	\$1962.41	\$2278.43	\$2364.16
					2,3	QBDF-2972-OZN				1768.56	1801.75	1974.22	2042.75	2358.77	2444.50
					7,8,9	QBDF-2972-OZN				1784.64	1817.83	1990.30	2058.83	2374.85	2460.58
					K	QBDF-2972-OZN	K			N/A	N/A	2114.54	2183.07	2499.09	2584.82
					Q	QBDF-2972-OZN	Q			N/A	N/A	2210.96	2279.49	2595.51	2681.24
Triple — 1H															
Hinged Door/ Lateral File/ Hinged Door	17"(432mm)	47 7/8"(1216mm)	48"(1219mm)	J	QBTF-1748-GAG	J				\$1923.87	\$1939.93	N/A	N/A	N/A	N/A
					2,3	QBTF-1748-GAG				1976.36	1992.42	2235.59	2342.71	2669.43	2755.12
					7,8,9	QBTF-1748-GAG				1992.44	2008.50	2251.67	2358.79	2685.51	2771.20
					K	QBTF-1748-GAG	K			N/A	N/A	2375.91	2483.03	2809.75	2895.44
					Q	QBTF-1748-GAG	Q			N/A	N/A	2472.33	2579.45	2906.17	2991.86
	59 7/8"(1521mm)	60"(1524mm)			1,J	QBTF-1760-GAG				\$1951.72	\$1972.06	\$2227.02	\$2337.35	\$2687.64	\$2780.83
					2,3	QBTF-1760-GAG				2032.06	2052.40	2307.36	2417.69	2767.98	2861.17
					7,8,9	QBTF-1760-GAG				2048.14	2068.48	2323.44	2433.77	2784.06	2877.25
					K	QBTF-1760-GAG	K			N/A	N/A	2447.68	2558.01	2908.30	3001.49
					Q	QBTF-1760-GAG	Q			N/A	N/A	2544.10	2654.43	3004.72	3097.91
	71 7/8"(1826mm)	72"(1829mm)			1,J	QBTF-1772-GAG				\$2007.42	\$2032.04	\$2298.79	\$2412.33	\$2786.19	\$2886.88
					2,3	QBTF-1772-GAG				2087.76	2112.38	2379.13	2492.67	2866.53	2967.22
					7,8,9	QBTF-1772-GAG				2103.84	2128.46	2395.21	2508.75	2882.61	2983.30
					K	QBTF-1772-GAG	K			N/A	N/A	2519.45	2632.99	3006.85	3107.54
					Q	QBTF-1772-GAG	Q			N/A	N/A	2615.87	2729.41	3103.27	3203.96

*Finished Height includes worksurface top, spacer, base unit and legs

Base Unit — Hinged Door and Drawer Combination

Description	Finished Height*	Actual Width	Nominal Width	Pull	Number	Case Laminate A				Wood Door					
						Steel Door Trim A	Trim B	Laminate Door A	Door B	Group A	Group B				
Triple — 1.5H															
Open/Box Drawer with Hinged Door/ Open	23"(584mm)	47 7/8"(1216mm)	48"(1219mm)	J	QBTF-2348-ZMZ	J				\$1588.59	\$1608.93	N/A	N/A	N/A	N/A
					2,3	QBTF-2348-ZMZ				1641.08	1661.42	1900.31	2007.43	2334.15	2419.84
					7,8,9	QBTF-2348-ZMZ				1657.16	1677.50	1916.39	2023.51	2350.23	2435.92
					K	QBTF-2348-ZMZ	K			N/A	N/A	2040.63	2147.75	2474.47	2560.16
					Q	QBTF-2348-ZMZ	Q			N/A	N/A	2137.05	2244.17	2570.89	2656.58
	59 7/8"(1521mm)	60"(1524mm)			1,J	QBTF-2360-ZMZ				\$1631.44	\$1656.06	\$1906.74	\$2017.07	\$2367.36	\$2460.55
					2,3	QBTF-2360-ZMZ				1711.78	1736.40	1987.08	2097.41	2447.70	2540.89
					7,8,9	QBTF-2360-ZMZ				1727.86	1752.48	2003.16	2113.49	2463.78	2556.97
					K	QBTF-2360-ZMZ	K			N/A	N/A	2127.40	2237.73	2588.02	2681.21
					Q	QBTF-2360-ZMZ	Q			N/A	N/A	2223.82	2334.15	2684.44	2777.63
	71 7/8"(1826mm)	72"(1829mm)			1,J	QBTF-2372-ZMZ				\$1702.14	\$1731.04	\$1993.51	\$2107.05	\$2480.91	\$2581.60
					2,3	QBTF-2372-ZMZ				1782.48	1811.38	2073.85	2187.39	2561.25	2661.94
					7,8,9	QBTF-2372-ZMZ				1798.56	1827.46	2089.93	2203.47	2577.33	2678.02
					K	QBTF-2372-ZMZ	K			N/A	N/A	2214.17	2327.71	2701.57	2802.26
					Q	QBTF-2372-ZMZ	Q			N/A	N/A	2310.59	2424.13	2797.99	2898.68
Hinged Door/ Box Drawer with Hinged Door/ Hinged Door	23"(584mm)	47 7/8"(1216mm)	48"(1219mm)	J	QBTF-2348-HMH	J				\$1620.73	\$1641.07	N/A	N/A	N/A	N/A
					2,3	QBTF-2348-HMH				1726.78	1747.12	1986.01	2093.13	2419.85	2505.54
					7,8,9	QBTF-2348-HMH				1753.58	1773.92	2012.81	2119.93	2446.65	2532.34
					K	QBTF-2348-HMH	K			N/A	N/A	2201.31	2308.43	2635.15	2720.84
					Q	QBTF-2348-HMH	Q			N/A	N/A	2362.01	2469.13	2795.85	2881.54
	59 7/8"(1521mm)	60"(1524mm)			1,J	QBTF-2360-HMH				\$1648.58	\$1673.20	\$1923.88	\$2034.21	\$2384.50	\$2477.69
					2,3	QBTF-2360-HMH				1782.48	1807.10	2057.78	2168.11	2518.40	2611.59
					7,8,9	QBTF-2360-HMH				1809.28	1833.90	2084.58	2194.91	2545.20	2638.39
					K	QBTF-2360-HMH	K			N/A	N/A	2273.08	2383.41	2733.70	2826.89
					Q	QBTF-2360-HMH	Q			N/A	N/A	2433.78	2544.11	2894.40	2987.59
	71 7/8"(1826mm)	72"(1829mm)			1,J	QBTF-2372-HMH				\$1704.28	\$1733.18	\$1995.65	\$2109.19	\$2483.05	\$2583.74
					2,3	QBTF-2372-HMH				1838.18	1867.08	2129.55	2243.09	2616.95	2717.64
					7,8,9	QBTF-2372-HMH				1864.98	1893.88	2156.35	2269.89	2643.75	2744.44
					K	QBTF-2372-HMH	K			N/A	N/A	2344.85	2458.39	2832.25	2932.94
					Q	QBTF-2372-HMH	Q			N/A	N/A	2505.55	2619.09	2992.95	3093.64
Hinged Door/ Box Drawer and Lateral File/ Hinged Door	23"(584mm)	47 7/8"(1216mm)	48"(1219mm)	J	QBTF-2348-HBH	J				\$2119.91	\$2140.25	N/A	N/A	N/A	N/A
					2,3	QBTF-2348-HBH				2199.18	2219.52	2458.41	2565.53	2892.25	2977.94
					7,8,9	QBTF-2348-HBH				2220.62	2240.96	2479.85	2586.97	2913.69	2999.38
					K	QBTF-2348-HBH	K			N/A	N/A	2636.22	2743.34	3070.06	3155.75
					Q	QBTF-2348-HBH	Q			N/A	N/A	2764.78	2871.90	3198.62	3284.31
	59 7/8"(1521mm)	60"(1524mm)			1,J	QBTF-2360-HBH				\$2147.76	\$2172.38	\$2423.06	\$2533.39	\$2883.68	\$2976.87
					2,3	QBTF-2360-HBH				2254.88	2279.50	2530.18	2640.51	2990.80	3083.99
					7,8,9	QBTF-2360-HBH				2276.32	2300.94	2551.62	2661.95	3012.24	3105.43
					K	QBTF-2360-HBH	K			N/A	N/A	2707.99	2818.32	3168.61	3261.80
					Q	QBTF-2360-HBH	Q			N/A	N/A	2836.55	2946.88	3297.17	3390.36
	71 7/8"(1826mm)	72"(1829mm)			1,J	QBTF-2372-HBH				\$2203.46	\$2232.36	\$2494.83	\$2608.37	\$2982.23	\$3082.92
					2,3	QBTF-2372-HBH				2310.58	2339.48	2601.95	2715.49	3089.35	3190.04
					7,8,9	QBTF-2372-HBH				2332.02	2360.92	2623.39	2736.93	3110.79	3211.48
					K	QBTF-2372-HBH	K			N/A	N/A	2779.76	2893.30	3267.16	3367.85
					Q	QBTF-2372-HBH	Q			N/A	N/A	2908.32	3021.86	3395.72	3496.41

*Finished Height includes worksurface top, spacer, base unit and legs

Base Unit — Hinged Door and Drawer Combination

Description	Finished Height*	Actual Width	Nominal Width	Pull	Number	Case Laminate B				Steel Door		Laminate Door		Wood Door	
						①	②	③	④	Trim A	Trim B	A	B	Group A	Group B
Single — 1.5H															
Box Drawer/12"H Hinged Door	23"(584mm)	23 7/8"(606mm)	24"(610mm)	J	QBSF-2324-MNN	J				\$ 994.07	\$1005.85	N/A	N/A	N/A	N/A
					2,3	QBSF-2324-MNN				1046.56	1058.34	1164.39	1207.24	1373.28	1416.13
					7,8,9	QBSF-2324-MNN				1062.64	1074.42	1180.47	1223.32	1389.36	1432.21
					K	QBSF-2324-MNN	K			N/A	N/A	1304.71	1347.56	1513.60	1556.45
					Q	QBSF-2324-MNN	Q			N/A	N/A	1401.13	1443.98	1610.02	1652.87
	29 7/8"(759mm)	30"(762mm)			1, J	QBSF-2330-MNN				\$1021.92	\$1035.84	\$1149.39	\$1195.45	\$1377.56	\$1425.77
					2,3	QBSF-2330-MNN				1102.26	1116.18	1229.73	1275.79	1457.90	1506.11
					7,8,9	QBSF-2330-MNN				1118.34	1132.26	1245.81	1291.87	1473.98	1522.19
					K	QBSF-2330-MNN	K			N/A	N/A	1370.05	1416.11	1598.22	1646.43
					Q	QBSF-2330-MNN	Q			N/A	N/A	1466.47	1512.53	1694.64	1742.85
	35 7/8"(911mm)	36"(914mm)			1, J	QBSF-2336-MNN				\$1077.62	\$1093.68	\$1214.73	\$1264.00	\$1462.18	\$1515.75
					2,3	QBSF-2336-MNN				1157.96	1174.02	1295.07	1344.34	1542.52	1596.09
					7,8,9	QBSF-2336-MNN				1174.04	1190.10	1311.15	1360.42	1558.60	1612.17
					K	QBSF-2336-MNN	K			N/A	N/A	1435.39	1484.66	1682.84	1736.41
					Q	QBSF-2336-MNN	Q			N/A	N/A	1531.81	1581.08	1779.26	1832.83
Single — 2H															
Box Drawer/18"H Hinged Door	29"(737mm)	23 7/8"(606mm)	24"(610mm)	J	QBSF-2924-ONN	J				\$1152.62	\$1168.69	N/A	N/A	N/A	N/A
					2,3	QBSF-2924-ONN				1205.11	1221.18	1333.65	1376.50	1563.96	1606.81
					7,8,9	QBSF-2924-ONN				1221.19	1237.26	1349.73	1392.58	1580.04	1622.89
					K	QBSF-2924-ONN	K			N/A	N/A	1473.97	1516.82	1704.28	1747.13
					Q	QBSF-2924-ONN	Q			N/A	N/A	1570.39	1613.24	1800.70	1843.55
	29 7/8"(759mm)	30"(762mm)			1, J	QBSF-2930-ONN				\$1189.04	\$1207.25	\$1327.22	\$1373.28	\$1576.81	\$1625.02
					2,3	QBSF-2930-ONN				1269.38	1287.59	1407.56	1453.62	1657.15	1705.36
					7,8,9	QBSF-2930-ONN				1285.46	1303.67	1423.64	1469.70	1673.23	1721.44
					K	QBSF-2930-ONN	K			N/A	N/A	1547.88	1593.94	1797.47	1845.68
					Q	QBSF-2930-ONN	Q			N/A	N/A	1644.30	1690.36	1893.89	1942.10
	35 7/8"(911mm)	36"(914mm)			1, J	QBSF-2936-ONN				\$1253.31	\$1273.66	\$1401.13	\$1450.40	\$1670.00	\$1723.57
					2,3	QBSF-2936-ONN				1333.65	1354.00	1481.47	1530.74	1750.34	1803.91
					7,8,9	QBSF-2936-ONN				1349.73	1370.08	1497.55	1546.82	1766.42	1819.99
					K	QBSF-2936-ONN	K			N/A	N/A	1621.79	1671.06	1890.66	1944.23
					Q	QBSF-2936-ONN	Q			N/A	N/A	1718.21	1767.48	1987.08	2040.65
Double — 1.5H															
Open — Left Box Drawer/12"H Hinged Door	23"(584mm)	47 7/8"(1216mm)	48"(1219mm)	J	QBDF-2348-ZMN	J				\$1275.79	\$1296.13	N/A	N/A	N/A	N/A
					2,3	QBDF-2348-ZMN				1328.28	1348.62	1484.67	1540.36	1770.68	1834.97
					7,8,9	QBDF-2348-ZMN				1344.36	1364.70	1500.75	1556.44	1786.76	1851.05
					K	QBDF-2348-ZMN	K			N/A	N/A	1624.99	1680.68	1911.00	1975.29
					Q	QBDF-2348-ZMN	Q			N/A	N/A	1721.41	1777.10	2007.42	2071.71
	59 7/8"(1521mm)	60"(1524mm)			1, J	QBDF-2360-ZMN				\$1348.62	\$1373.24	\$1524.29	\$1586.40	\$1848.86	\$1923.87
					2,3	QBDF-2360-ZMN				1428.96	1453.58	1604.63	1666.74	1929.20	2004.21
					7,8,9	QBDF-2360-ZMN				1445.04	1469.66	1620.71	1682.82	1945.28	2020.29
					K	QBDF-2360-ZMN	K			N/A	N/A	1744.95	1807.06	2069.52	2144.53
					Q	QBDF-2360-ZMN	Q			N/A	N/A	1841.37	1903.48	2165.94	2240.95
	71 7/8"(1826mm)	72"(1829mm)			1, J	QBDF-2372-ZMN				\$1449.30	\$1478.20	\$1644.25	\$1712.78	\$2007.38	\$2093.11
					2,3	QBDF-2372-ZMN				1529.64	1558.54	1724.59	1793.12	2087.72	2173.45
					7,8,9	QBDF-2372-ZMN				1545.72	1574.62	1740.67	1809.20	2103.80	2189.53
					K	QBDF-2372-ZMN	K			N/A	N/A	1864.91	1933.44	2228.04	2313.77
					Q	QBDF-2372-ZMN	Q			N/A	N/A	1933.48	2002.01	2324.46	2410.19
Box Drawer/12"H Hinged Door Open — Right	23"(584mm)	47 7/8"(1216mm)	48"(1219mm)	J	QBDF-2348-MZN	J				\$1275.79	\$1296.13	N/A	N/A	N/A	N/A
					2,3	QBDF-2348-MZN				1328.28	1348.62	1484.67	1540.36	1770.68	1834.97
					7,8,9	QBDF-2348-MZN				1344.36	1364.70	1500.75	1556.44	1786.76	1851.05
					K	QBDF-2348-MZN	K			N/A	N/A	1624.99	1680.68	1911.00	1975.29
					Q	QBDF-2348-MZN	Q			N/A	N/A	1721.41	1777.10	2007.42	2071.71
	59 7/8"(1521mm)	60"(1524mm)			1, J	QBDF-2360-MZN				\$1348.62	\$1373.24	\$1524.29	\$1586.40	\$1848.86	\$1923.87
					2,3	QBDF-2360-MZN				1428.96	1453.58	1604.63	1666.74	1929.20	2004.21
					7,8,9	QBDF-2360-MZN				1445.04	1469.66	1620.71	1682.82	1945.28	2020.29
					K	QBDF-2360-MZN	K			N/A	N/A	1744.95	1807.06	2069.52	2144.53
					Q	QBDF-2360-MZN	Q			N/A	N/A	1841.37	1903.48	2165.94	2240.95
	71 7/8"(1826mm)	72"(1829mm)			1, J	QBDF-2372-MZN				\$1449.30	\$1478.20	\$1644.25	\$1712.78	\$2007.38	\$2093.11
					2,3	QBDF-2372-MZN				1529.64	1558.54	1724.59	1793.12	2087.72	2173.45
					7,8,9	QBDF-2372-MZN				1545.72	1574.62	1740.67	1809.20	2103.80	2189.53
					K	QBDF-2372-MZN	K			N/A	N/A	1864.91	1933.44	2228.04	2313.77
					Q	QBDF-2372-MZN	Q			N/A	N/A	1961.33	2029.86	2324.46	2410.19

Base Unit — Hinged Door and Drawer Combination

Description	Finished Height*	Actual Width	Nominal Width	Pull	Number	Case Laminate B				Steel Door		Laminate Door		Wood Door	
						1	2	3	4	Trim A	Trim B	A	B	Group A	Group B
Double — 2H															
Open — Left Box Drawer/18"H Hinged Door	29"(737mm)	47 7/8"(1216mm)	48"(1219mm)	J	QBDF-2948-ZON	J				\$1573.58	\$1598.21	N/A	N/A	N/A	N/A
					2,3	QBDF-2948-ZON				1626.07	1650.70	1793.17	1848.86	2100.60	2164.89
					7,8,9	QBDF-2948-ZON				1642.15	1666.78	1809.25	1864.94	2116.68	2180.97
					K	QBDF-2948-ZON	K			N/A	N/A	1933.49	1989.18	2240.92	2305.21
					Q	QBDF-2948-ZON	Q			N/A	N/A	2029.91	2085.60	2337.34	2401.63
	59 7/8"(1521mm)	60"(1524mm)			1,J	QBDF-2960-ZON				\$1652.85	\$1681.76	\$1839.23	\$1901.34	\$2185.22	\$2260.23
					2,3	QBDF-2960-ZON				1733.19	1762.10	1919.57	1981.68	2265.56	2340.57
					7,8,9	QBDF-2960-ZON				1749.27	1778.18	1935.65	1997.76	2281.64	2356.65
					K	QBDF-2960-ZON	K			N/A	N/A	2059.89	2122.00	2405.88	2480.89
					Q	QBDF-2960-ZON	Q			N/A	N/A	2156.31	2218.42	2502.30	2577.31
	71 7/8"(1826mm)	72"(1829mm)			1,J	QBDF-2972-ZON				\$1759.97	\$1793.16	\$1965.63	\$2034.16	\$2350.18	\$2435.91
					2,3	QBDF-2972-ZON				1840.31	1873.50	2045.97	2114.50	2430.52	2516.25
					7,8,9	QBDF-2972-ZON				1856.39	1889.58	2062.05	2130.58	2446.60	2532.33
					K	QBDF-2972-ZON	K			N/A	N/A	2186.29	2254.82	2570.84	2656.57
					Q	QBDF-2972-ZON	Q			N/A	N/A	2282.71	2351.24	2667.26	2752.99
Box Drawer/18"H Hinged Door Open — Right	29"(737mm)	47 7/8"(1216mm)	48"(1219mm)	J	QBDF-2948-OZN	J				\$1573.58	\$1598.21	N/A	N/A	N/A	N/A
					2,3	QBDF-2948-OZN				1626.07	1650.70	1793.17	1848.86	2100.60	2164.89
					7,8,9	QBDF-2948-OZN				1642.15	1666.78	1809.25	1864.94	2116.68	2180.97
					K	QBDF-2948-OZN	K			N/A	N/A	1933.49	1989.18	2240.92	2305.21
					Q	QBDF-2948-OZN	Q			N/A	N/A	2029.91	2085.60	2337.34	2401.63
	59 7/8"(1521mm)	60"(1524mm)			1,J	QBDF-2960-OZN				\$1652.85	\$1681.76	\$1839.23	\$1901.34	\$2185.22	\$2260.23
					2,3	QBDF-2960-OZN				1733.19	1762.10	1919.57	1981.68	2265.56	2340.57
					7,8,9	QBDF-2960-OZN				1749.27	1778.18	1935.65	1997.76	2281.64	2356.65
					K	QBDF-2960-OZN	K			N/A	N/A	2059.89	2122.00	2405.88	2480.89
					Q	QBDF-2960-OZN	Q			N/A	N/A	2156.31	2218.42	2502.30	2577.31
	71 7/8"(1826mm)	72"(1829mm)			1,J	QBDF-2972-OZN				\$1759.97	\$1793.16	\$1965.63	\$2034.16	\$2350.18	\$2435.91
					2,3	QBDF-2972-OZN				1840.31	1873.50	2045.97	2114.50	2430.52	2516.25
					7,8,9	QBDF-2972-OZN				1856.39	1889.58	2062.05	2130.58	2446.60	2532.33
					K	QBDF-2972-OZN	K			N/A	N/A	2186.29	2254.82	2570.84	2656.57
					Q	QBDF-2972-OZN	Q			N/A	N/A	2282.71	2351.24	2667.26	2752.99
Triple — 1H															
Hinged Door/ Lateral File/ Hinged Door	17"(432mm)	47 7/8"(1216mm)	48"(1219mm)	J	QBTF-1748-GAG	J				\$1974.21	\$1990.27	N/A	N/A	N/A	N/A
					2,3	QBTF-1748-GAG				2026.70	2042.76	2285.93	2393.05	2719.77	2805.46
					7,8,9	QBTF-1748-GAG				2042.78	2058.84	2302.01	2409.13	2735.85	2821.54
					K	QBTF-1748-GAG	K			N/A	N/A	2426.25	2533.37	2860.09	2945.78
					Q	QBTF-1748-GAG	Q			N/A	N/A	2522.67	2629.79	2956.51	3042.20
	59 7/8"(1521mm)	60"(1524mm)			1,J	QBTF-1760-GAG				\$2006.34	\$2026.68	\$2281.64	\$2391.97	\$2742.26	\$2835.45
					2,3	QBTF-1760-GAG				2086.68	2107.02	2361.98	2472.31	2822.60	2915.79
					7,8,9	QBTF-1760-GAG				2102.76	2123.10	2378.06	2488.39	2838.68	2931.87
					K	QBTF-1760-GAG	K			N/A	N/A	2502.30	2612.63	2962.92	3056.11
					Q	QBTF-1760-GAG	Q			N/A	N/A	2598.72	2709.05	3059.34	3152.53
	71 7/8"(1826mm)	72"(1829mm)			1,J	QBTF-1772-GAG				\$2066.32	\$2090.94	\$2357.69	\$2471.23	\$2845.09	\$2945.78
					2,3	QBTF-1772-GAG				2146.66	2171.28	2438.03	2551.57	2925.43	3026.12
					7,8,9	QBTF-1772-GAG				2162.74	2187.36	2454.11	2567.65	2941.51	3042.20
					K	QBTF-1772-GAG	K			N/A	N/A	2578.35	2691.89	3065.75	3166.44
					Q	QBTF-1772-GAG	Q			N/A	N/A	2674.77	2788.31	3162.17	3262.86

*Finished Height includes worksurface top, spacer, base unit and legs

Base Unit — Hinged Door and Drawer Combination

Description	Finished Height*	Actual Width	Nominal Width	Pull	Number	Case Laminate B				Wood Door				
						Steel Door Trim A	Trim B	Laminate Door A	Laminate Door B	Group A	Group B			
Triple — 1.5H														
Open/Box Drawer with Hinged Door/ Open	23"(584mm)	47 7/8"(1216mm)	48"(1219mm)	J	QBTF-2348-ZMZ	1	J	\$1645.35	\$1665.69	N/A	N/A	N/A	N/A	
						2,3	QBTF-2348-ZMZ	\$1697.84	1718.18	1957.07	2064.19	2390.91	2476.60	
						7,8,9	QBTF-2348-ZMZ	1713.92	1734.26	1973.15	2080.27	2406.99	2492.68	
						K	QBTF-2348-ZMZ	N/A	N/A	2097.39	2204.51	2531.23	2616.92	
	59 7/8"(1521mm)	60"(1524mm)	1, J	QBTF-2360-ZMZ	1	J	\$1692.48	\$1717.10	\$1967.78	\$2078.11	\$2428.40	\$2521.59		
					2,3	QBTF-2360-ZMZ	1772.82	1797.44	2048.12	2158.45	2508.74	2601.93		
					7,8,9	QBTF-2360-ZMZ	1788.90	1813.52	2064.20	2174.53	2524.82	2618.01		
					K	QBTF-2360-ZMZ	N/A	N/A	2188.44	2298.77	2649.06	2742.25		
	71 7/8"(1826mm)	72"(1829mm)	1, J	QBTF-2372-ZMZ	1	J	\$1767.46	\$1796.36	\$2058.83	\$2172.37	\$2546.23	\$2646.92		
					2,3	QBTF-2372-ZMZ	1847.80	1876.70	2139.17	2252.71	2626.57	2727.26		
					7,8,9	QBTF-2372-ZMZ	1863.88	1892.78	2155.25	2268.79	2642.65	2743.34		
					K	QBTF-2372-ZMZ	N/A	N/A	2279.49	2393.03	2766.89	2867.58		
	Hinged Door/ Box Drawer with Hinged Door/ Hinged Door	23"(584mm)	47 7/8"(1216mm)	48"(1219mm)	J	QBTF-2348-HMH	1	J	\$1677.49	\$1697.83	N/A	N/A	N/A	N/A
							2,3	QBTF-2348-HMH	1783.54	1803.88	2042.77	2149.89	2476.61	2562.30
							7,8,9	QBTF-2348-HMH	1810.34	1830.68	2069.57	2176.69	2503.41	2589.10
							K	QBTF-2348-HMH	N/A	N/A	2258.07	2365.19	2691.91	2777.60
59 7/8"(1521mm)		60"(1524mm)	1, J	QBTF-2360-HMH	1	J	\$1709.62	\$1734.24	\$1984.92	\$2095.25	\$2445.54	\$2538.73		
					2,3	QBTF-2360-HMH	1843.52	1868.14	2118.82	2229.15	2579.44	2672.63		
					7,8,9	QBTF-2360-HMH	1870.32	1894.94	2145.62	2255.95	2606.24	2699.43		
					K	QBTF-2360-HMH	N/A	N/A	2334.12	2444.45	2794.74	2887.93		
71 7/8"(1826mm)		72"(1829mm)	1, J	QBTF-2372-HMH	1	J	\$1769.60	\$1798.50	\$2060.97	\$2174.51	\$2548.37	\$2649.06		
					2,3	QBTF-2372-HMH	1903.50	1932.40	2194.87	2308.41	2682.27	2782.96		
					7,8,9	QBTF-2372-HMH	1930.30	1959.20	2221.67	2335.21	2709.07	2809.76		
					K	QBTF-2372-HMH	N/A	N/A	2410.17	2523.71	2897.57	2998.26		
Hinged Door/ Box Drawer and Lateral File/ Hinged Door		23"(584mm)	47 7/8"(1216mm)	48"(1219mm)	J	QBTF-2348-HBH	1	J	\$2176.67	\$2197.01	N/A	N/A	N/A	N/A
							2,3	QBTF-2348-HBH	2255.94	2276.28	2515.17	2622.29	2949.01	3034.70
							7,8,9	QBTF-2348-HBH	2277.38	2297.72	2536.61	2643.73	2970.45	3056.14
							K	QBTF-2348-HBH	N/A	N/A	2692.98	2800.10	3126.82	3212.51
	59 7/8"(1521mm)	60"(1524mm)	1, J	QBTF-2360-HBH	1	J	\$2208.80	\$2233.42	\$2484.10	\$2594.43	\$2944.72	\$3037.91		
					2,3	QBTF-2360-HBH	2315.92	2340.54	2591.22	2701.55	3051.84	3145.03		
					7,8,9	QBTF-2360-HBH	2337.36	2361.98	2612.66	2722.99	3073.28	3166.47		
					K	QBTF-2360-HBH	N/A	N/A	2769.03	2879.36	3229.65	3322.84		
	71 7/8"(1826mm)	72"(1829mm)	1, J	QBTF-2372-HBH	1	J	\$2268.78	\$2297.68	\$2560.15	\$2673.69	\$3047.55	\$3148.24		
					2,3	QBTF-2372-HBH	2375.90	2404.80	2667.27	2780.81	3154.67	3255.36		
					7,8,9	QBTF-2372-HBH	2397.34	2426.24	2688.71	2802.25	3176.11	3276.80		
					K	QBTF-2372-HBH	N/A	N/A	2845.08	2958.62	3332.48	3433.17		
							1	J	N/A	N/A	2973.64	3087.18	3461.04	3561.73

*Finished Height includes worksurface top, spacer, base unit and legs

This page intentionally blank

Base Unit — Single Sliding Door

Single Sliding Door

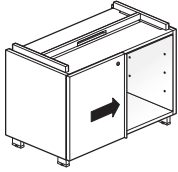

QBDF-SZN
(Proud left)

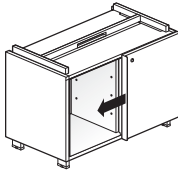

QBDF-ZTN
(Proud right)

Features

- Sliding Door include:
 - Laminate case standard with a painted steel inset back, proud door and base.
 - Legs and door options.
 - Spacer
 - Vertical pull
- Open storage dimensions:
 - 1H
 - 1.5H
 - 2H
- Leg Options:
 - Straight Leg (F); requires trim color.
 - Chamfer Leg (P); requires trim color.
- Glide adjustment range:
 - Straight Leg: 1.5”(38mm)
 - Chamfer Leg: 1.25”(32mm)
- Spacer:
 - 1.18”(30mm) high
 - End pieces come in specified color; center spacer section black only.
- Sliding door options include painted, laminate or wood.
- Lock Option:
 - Locking (chrome only) and non-locking available.
- Case ships assembled. Legs require field installation.

Specification Tips

- Designed to be used with Haworth’s Integrated Palette, UniGroup Too, PREMISE, Reside Desking and/or Belong Work Tools.
- Beside base units 24”-42”(610mm-1067mm) cannot be freestanding. Units must be attached or ganged together. All base units with drawers must be attached. Refer to Specification Guide for planning information.
- Beside base units 48”-72”(1219mm-1829mm) widths can be freestanding.
- Separately specified storage tops are required and can match the width of a single base unit or span two or more adjacent base units side by side.
- To route and access power in storage, order separately specified Belong power components.
- 1.5H and 2H storage can be used to support Reside desking or Adaptable worksurface in a perpendicular configuration with separately specified brackets. Refer to Specification Guide for planning information.
- Beside base storage unit with top, spacer, base unit and legs finished heights:
 - 1H = 17”(432mm)
 - 1.5H = 23”(584mm)
 - 2H = 29”(737mm)
- Separately specified if applicable:
 - Belong Power and communication cabling, tools, screens and tool rails.
 - Storage-to-Panel Bracket
 - Storage Attachment Bracket
 - Ganging Bracket
 - Storage Top (required)
 - Filler Panel
 - Top Filler Track
 - Finished Back (recommended when back is exposed)
 - Adjustable Shelf (not included with unit)
 - Stack-On Hutch
- Refer to Specification Guide for planning information and actual dimensions.

Notes: 2H storage base units are not designed to fit under Reside benching or return worksurfaces. Reside Desking or Adaptable worksurfaces can be attached to the front or back of a 2H Beside storage unit with separately specified flush mount plates.

Separately specified Belong base unit power components available for 30”-72”(372mm-1829mm) widths only.

Storage shelves are unique to the specific base unit configuration. Refer to shelf price list pages for appropriate shelf.

1H units cannot accept binders.

To Order, Specify:

Steel Door Front

- 1) Product number, including:

① Door Front Option:

S Steel

② Leg Option:

F Straight Leg

P Chamfer Leg, add **\$85.70** list

③ Lock Option:

L Locking, add **\$42.85** list

N Non-Locking

- 2) Case laminate color.
- 3) Case laminate edgeband color.
- 4) Bottom, inset back and fixed shelf trim color.
- 5) Pull, leg and spacer trim color.
- 6) Door front color.

Laminate or Wood Door Front

- 1) Product number, including:

① Door Front Option:

L Laminate

W Wood

② Leg Option

F Straight Leg

P Chamfer Leg, add **\$85.70** list

③ Lock Option:

L Locking, add **\$42.85** list

N Non-Locking

- 2) Case laminate color.
- 3) Case laminate edgeband color.
- 4) Bottom, inset back and fixed shelf trim color.
- 5) Pull, leg and spacer trim color.
- 6) Door front color.
- 7) Laminate front edgeband color.

Note: Upcharge for mixed grade fabric or trim surfaces, refer to the electronic design and specification tools for pricing.

Base Unit — Single Sliding Door

Description	Finished Height*	Actual Width	Nominal Width	Number	Case Laminate A			Steel Door		Laminate Door		Wood Door	
					①	②	③	Trim A	Trim B	A	B	Group A	Group B
1H													
Proud Sliding Door – Left	17"(432mm)	23 7/8"(606mm)	24"(610mm)	QBDF-1724-SZN	N			\$ 877.32	\$ 884.82	\$ 984.44	\$ 1027.29	\$ 1171.90	\$ 1214.75
		29 7/8"(759mm)	30"(762mm)	QBDF-1730-SZN	N			953.37	963.01	1070.13	1116.19	1276.87	1325.08
		35 7/8"(911mm)	36"(914mm)	QBDF-1736-SZN	N			1029.42	1041.20	1155.82	1205.09	1381.84	1435.41
		41 7/8"(1064mm)	42"(1067mm)	QBDF-1742-SZN	N			1105.47	1119.39	1241.51	1293.99	1486.81	1545.74
		47 7/8"(1216mm)	48"(1219mm)	QBDF-1748-SZN	N			1181.52	1197.58	1327.20	1382.89	1591.78	1656.07
		59 7/8"(1521mm)	60"(1524mm)	QBDF-1760-SZN	N			1333.62	1353.96	1498.58	1560.69	1801.72	1876.73
		71 7/8"(1521mm)	72"(1829mm)	QBDF-1772-SZN	N			1485.72	1510.34	1669.96	1738.49	2011.66	2097.39
Proud Sliding Door – Right	17"(432mm)	23 7/8"(606mm)	24"(610mm)	QBDF-1724-ZTN	N			\$ 877.32	\$ 884.82	\$ 984.44	\$ 1027.29	\$ 1171.90	\$ 1214.75
		29 7/8"(759mm)	30"(762mm)	QBDF-1730-ZTN	N			953.37	963.01	1070.13	1116.19	1276.87	1325.08
		35 7/8"(911mm)	36"(914mm)	QBDF-1736-ZTN	N			1029.42	1041.20	1155.82	1205.09	1381.84	1435.41
		41 7/8"(1064mm)	42"(1067mm)	QBDF-1742-ZTN	N			1105.47	1119.39	1241.51	1293.99	1486.81	1545.74
		47 7/8"(1216mm)	48"(1219mm)	QBDF-1748-ZTN	N			1181.52	1197.58	1327.20	1382.89	1591.78	1656.07
		59 7/8"(1521mm)	60"(1524mm)	QBDF-1760-ZTN	N			1333.62	1353.96	1498.58	1560.69	1801.72	1876.73
		71 7/8"(1521mm)	72"(1829mm)	QBDF-1772-ZTN	N			1485.72	1510.34	1669.96	1738.49	2011.66	2097.39
1.5H													
Proud Sliding Door – Left	23"(584mm)	23 7/8"(606mm)	24"(610mm)	QBDF-2324-SZN	N			\$ 918.02	\$ 929.80	\$ 1035.85	\$ 1078.70	\$ 1244.74	\$ 1287.59
		29 7/8"(759mm)	30"(762mm)	QBDF-2330-SZN	N			990.86	1004.78	1118.33	1164.39	1346.50	1394.71
		35 7/8"(911mm)	36"(914mm)	QBDF-2336-SZN	N			1063.70	1079.76	1200.81	1250.08	1448.26	1501.83
		41 7/8"(1064mm)	42"(1067mm)	QBDF-2342-SZN	N			1136.54	1154.74	1283.29	1335.77	1550.02	1608.95
		47 7/8"(1216mm)	48"(1219mm)	QBDF-2348-SZN	N			1209.38	1229.72	1365.77	1421.46	1651.78	1716.07
		59 7/8"(1521mm)	60"(1524mm)	QBDF-2360-SZN	N			1355.06	1379.68	1530.73	1592.84	1855.30	1930.31
		71 7/8"(1521mm)	72"(1829mm)	QBDF-2372-SZN	N			1500.74	1529.64	1695.69	1764.22	2058.82	2144.55
Proud Sliding Door – Right	23"(584mm)	23 7/8"(606mm)	24"(610mm)	QBDF-2324-ZTN	N			\$ 918.02	\$ 929.80	\$ 1035.85	\$ 1078.70	\$ 1244.74	\$ 1287.59
		29 7/8"(759mm)	30"(762mm)	QBDF-2330-ZTN	N			990.86	1004.78	1118.33	1164.39	1346.50	1394.71
		35 7/8"(911mm)	36"(914mm)	QBDF-2336-ZTN	N			1063.70	1079.76	1200.81	1250.08	1448.26	1501.83
		41 7/8"(1064mm)	42"(1067mm)	QBDF-2342-ZTN	N			1136.54	1154.74	1283.29	1335.77	1550.02	1608.95
		47 7/8"(1216mm)	48"(1219mm)	QBDF-2348-ZTN	N			1209.38	1229.72	1365.77	1421.46	1651.78	1716.07
		59 7/8"(1521mm)	60"(1524mm)	QBDF-2360-ZTN	N			1355.06	1379.68	1530.73	1592.84	1855.30	1930.31
		71 7/8"(1521mm)	72"(1829mm)	QBDF-2372-ZTN	N			1500.74	1529.64	1695.69	1764.22	2058.82	2144.55
2H													
Proud Sliding Door – Left	29"(737mm)	23 7/8"(606mm)	24"(610mm)	QBDF-2924-SZN	N			\$ 1084.06	\$ 1100.13	\$ 1212.60	\$ 1255.45	\$ 1442.91	\$ 1485.76
		29 7/8"(759mm)	30"(762mm)	QBDF-2930-SZN	N			1189.04	1207.25	1327.22	1373.28	1576.81	1625.02
		35 7/8"(911mm)	36"(914mm)	QBDF-2936-SZN	N			1294.02	1314.37	1441.84	1491.11	1710.71	1764.28
		41 7/8"(1064mm)	42"(1067mm)	QBDF-2942-SZN	N			1399.00	1421.49	1556.46	1608.94	1844.61	1903.54
		47 7/8"(1216mm)	48"(1219mm)	QBDF-2948-SZN	N			1503.98	1528.61	1671.08	1726.77	1978.51	2042.80
		59 7/8"(1521mm)	60"(1524mm)	QBDF-2960-SZN	N			1713.94	1742.85	1900.32	1962.43	2246.31	2321.32
		71 7/8"(1521mm)	72"(1829mm)	QBDF-2972-SZN	N			1923.90	1957.09	2129.56	2198.09	2514.11	2599.84
Proud Sliding Door – Right	29"(737mm)	23 7/8"(606mm)	24"(610mm)	QBDF-2924-ZTN	N			\$ 1084.06	\$ 1100.13	\$ 1212.60	\$ 1255.45	\$ 1442.91	\$ 1485.76
		29 7/8"(759mm)	30"(762mm)	QBDF-2930-ZTN	N			1189.04	1207.25	1327.22	1373.28	1576.81	1625.02
		35 7/8"(911mm)	36"(914mm)	QBDF-2936-ZTN	N			1294.02	1314.37	1441.84	1491.11	1710.71	1764.28
		41 7/8"(1064mm)	42"(1067mm)	QBDF-2942-ZTN	N			1399.00	1421.49	1556.46	1608.94	1844.61	1903.54
		47 7/8"(1216mm)	48"(1219mm)	QBDF-2948-ZTN	N			1503.98	1528.61	1671.08	1726.77	1978.51	2042.80
		59 7/8"(1521mm)	60"(1524mm)	QBDF-2960-ZTN	N			1713.94	1742.85	1900.32	1962.43	2246.31	2321.32
		71 7/8"(1521mm)	72"(1829mm)	QBDF-2972-ZTN	N			1923.90	1957.09	2129.56	2198.09	2514.11	2599.84

*Finished height is for fully assembled base unit including separately specified top.

Base Unit — Single Sliding Door

Description	Finished Height*	Actual Width	Nominal Width	Number	Case Laminate B			Steel Door		Laminate Door		Wood Door	
					①	②	③	Trim A	Trim B	A	B	Group A	Group B
1H													
Proud Sliding Door – Left	17”(432mm)	23 7/8”(606mm)	24”(610mm)	QBDF-1724-SZN	N			\$ 919.10	\$ 926.60	\$1026.22	\$1069.07	\$1213.68	\$1256.53
		29 7/8”(759mm)	30”(762mm)	QBDF-1730-SZN	N			997.29	1006.93	1114.05	1160.11	1320.79	1369.00
		35 7/8”(911mm)	36”(914mm)	QBDF-1736-SZN	N			1075.48	1087.26	1201.88	1251.15	1427.90	1481.47
		41 7/8”(1064mm)	42”(1067mm)	QBDF-1742-SZN	N			1153.67	1167.59	1289.71	1342.19	1535.01	1593.94
		47 7/8”(1216mm)	48”(1219mm)	QBDF-1748-SZN	N			1231.86	1247.92	1377.54	1433.23	1642.12	1706.41
		59 7/8”(1521mm)	60”(1524mm)	QBDF-1760-SZN	N			1388.24	1408.58	1553.20	1615.31	1856.34	1931.35
		71 7/8”(1521mm)	72”(1829mm)	QBDF-1772-SZN	N			1544.62	1569.24	1728.86	1797.39	2070.56	2156.29
Proud Sliding Door – Right	17”(432mm)	23 7/8”(606mm)	24”(610mm)	QBDF-1724-ZTN	N			\$ 919.10	\$ 926.60	\$1026.22	\$1069.07	\$1213.68	\$1256.53
		29 7/8”(759mm)	30”(762mm)	QBDF-1730-ZTN	N			997.29	1006.93	1114.05	1160.11	1320.79	1369.00
		35 7/8”(911mm)	36”(914mm)	QBDF-1736-ZTN	N			1075.48	1087.26	1201.88	1251.15	1427.90	1481.47
		41 7/8”(1064mm)	42”(1067mm)	QBDF-1742-ZTN	N			1153.67	1167.59	1289.71	1342.19	1535.01	1593.94
		47 7/8”(1216mm)	48”(1219mm)	QBDF-1748-ZTN	N			1231.86	1247.92	1377.54	1433.23	1642.12	1706.41
		59 7/8”(1521mm)	60”(1524mm)	QBDF-1760-ZTN	N			1388.24	1408.58	1553.20	1615.31	1856.34	1931.35
		71 7/8”(1521mm)	72”(1829mm)	QBDF-1772-ZTN	N			1544.62	1569.24	1728.86	1797.39	2070.56	2156.29
1.5H													
Proud Sliding Door – Left	23”(584mm)	23 7/8”(606mm)	24”(610mm)	QBDF-2324-SZN	N			\$ 966.22	\$ 978.00	\$1084.05	\$1126.90	\$1292.94	\$1335.79
		29 7/8”(759mm)	30”(762mm)	QBDF-2330-SZN	N			1041.20	1055.12	1168.67	1214.73	1396.84	1445.05
		35 7/8”(911mm)	36”(914mm)	QBDF-2336-SZN	N			1116.18	1132.24	1253.29	1302.56	1500.74	1554.31
		41 7/8”(1064mm)	42”(1067mm)	QBDF-2342-SZN	N			1191.16	1209.36	1337.91	1390.39	1604.64	1663.57
		47 7/8”(1216mm)	48”(1219mm)	QBDF-2348-SZN	N			1266.14	1286.48	1422.53	1478.22	1708.54	1772.83
		59 7/8”(1521mm)	60”(1524mm)	QBDF-2360-SZN	N			1416.10	1440.72	1591.77	1653.88	1916.34	1991.35
		71 7/8”(1521mm)	72”(1829mm)	QBDF-2372-SZN	N			1566.06	1594.96	1761.01	1829.54	2124.14	2209.87
Proud Sliding Door – Right	23”(584mm)	23 7/8”(606mm)	24”(610mm)	QBDF-2324-ZTN	N			\$ 966.22	\$ 978.00	\$1084.05	\$1126.90	\$1292.94	\$1335.79
		29 7/8”(759mm)	30”(762mm)	QBDF-2330-ZTN	N			1041.20	1055.12	1168.67	1214.73	1396.84	1445.05
		35 7/8”(911mm)	36”(914mm)	QBDF-2336-ZTN	N			1116.18	1132.24	1253.29	1302.56	1500.74	1554.31
		41 7/8”(1064mm)	42”(1067mm)	QBDF-2342-ZTN	N			1191.16	1209.36	1337.91	1390.39	1604.64	1663.57
		47 7/8”(1216mm)	48”(1219mm)	QBDF-2348-ZTN	N			1266.14	1286.48	1422.53	1478.22	1708.54	1772.83
		59 7/8”(1521mm)	60”(1524mm)	QBDF-2360-ZTN	N			1416.10	1440.72	1591.77	1653.88	1916.34	1991.35
		71 7/8”(1521mm)	72”(1829mm)	QBDF-2372-ZTN	N			1566.06	1594.96	1761.01	1829.54	2124.14	2209.87
2H													
Proud Sliding Door – Left	29”(737mm)	23 7/8”(606mm)	24”(610mm)	QBDF-2924-SZN	N			\$1138.69	\$1154.76	\$1267.23	\$1310.08	\$1497.54	\$1540.39
		29 7/8”(759mm)	30”(762mm)	QBDF-2930-SZN	N			1245.81	1264.02	1383.99	1430.05	1633.58	1681.79
		35 7/8”(911mm)	36”(914mm)	QBDF-2936-SZN	N			1352.93	1373.28	1500.75	1550.02	1769.62	1823.19
		41 7/8”(1064mm)	42”(1067mm)	QBDF-2942-SZN	N			1460.05	1482.54	1617.51	1669.99	1905.66	1964.59
		47 7/8”(1216mm)	48”(1219mm)	QBDF-2948-SZN	N			1567.17	1591.80	1734.27	1789.96	2041.70	2105.99
		59 7/8”(1521mm)	60”(1524mm)	QBDF-2960-SZN	N			1781.41	1810.32	1967.79	2029.90	2313.78	2388.79
		71 7/8”(1521mm)	72”(1829mm)	QBDF-2972-SZN	N			1995.65	2028.84	2201.31	2269.84	2585.86	2671.59
Proud Sliding Door – Right	29”(737mm)	23 7/8”(606mm)	24”(610mm)	QBDF-2924-ZTN	N			\$1138.69	\$1154.76	\$1267.23	\$1310.08	\$1497.54	\$1540.39
		29 7/8”(759mm)	30”(762mm)	QBDF-2930-ZTN	N			1245.81	1264.02	1383.99	1430.05	1633.58	1681.79
		35 7/8”(911mm)	36”(914mm)	QBDF-2936-ZTN	N			1352.93	1373.28	1500.75	1550.02	1769.62	1823.19
		41 7/8”(1064mm)	42”(1067mm)	QBDF-2942-ZTN	N			1460.05	1482.54	1617.51	1669.99	1905.66	1964.59
		47 7/8”(1216mm)	48”(1219mm)	QBDF-2948-ZTN	N			1567.17	1591.80	1734.27	1789.96	2041.70	2105.99
		59 7/8”(1521mm)	60”(1524mm)	QBDF-2960-ZTN	N			1781.41	1810.32	1967.79	2029.90	2313.78	2388.79
		71 7/8”(1521mm)	72”(1829mm)	QBDF-2972-ZTN	N			1995.65	2028.84	2201.31	2269.84	2585.86	2671.59

*Finished height is for fully assembled base unit including separately specified top.

This page intentionally blank

Base Unit — Double Sliding Door

Double Sliding Door

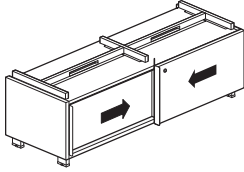

QBDF-QNN

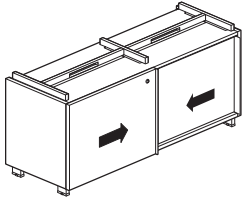

QBDF-PNN

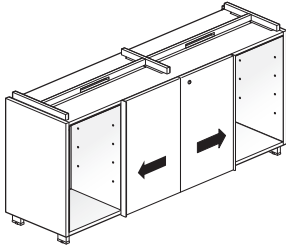

QBTF-ZRZ

Features

- Sliding Door — Double and Triple include:
 - Laminate case standard with a painted steel inset back and base.
 - Leg and door options.
 - Spacer
 - Vertical Pull
- Open storage dimensions:
 - 1H
 - 1.5H
 - 2H
- Leg Options:
 - Straight Leg (F); requires trim color.
 - Chamfer Leg (P); requires trim color.
- Glide adjustment range:
 - Straight Leg: 1.5”(38mm)
 - Chamfer Leg: 1.25”(32mm)
- Spacer:
 - 1.18”(30mm) high
 - End pieces come in specified color; center spacer section black only.
- Sliding door options include painted, laminate or wood.
- Lock Option:
 - Locking (chrome only) and non-locking available.
- Case ships assembled. Legs require field installation.

Specification Tips

- Designed to be used with Haworth’s Integrated Palette, UniGroup Too, PREMISE, Reside Desking and/or Belong Work Tools.
- Beside base units 24”-42”(610mm-1067mm) cannot be freestanding. Units must be attached or ganged together. All base units with drawers must be attached. Refer to Specification Guide for planning information.
- Beside base units 48”-72”(1219mm-1829mm) widths can be freestanding.
- Separately specified storage tops are required and can match the width of a single base unit or span two or more adjacent base units side by side.
- To route and access power in storage, order separately specified Belong power components.
- 1.5H and 2H storage can be used to support Reside desking or Adaptable worksurface in a perpendicular configuration with separately specified brackets. Refer to Specification Guide for planning information.
- Beside base storage unit with top, spacer, base unit and legs finished heights:
 - 1H = 17”(432mm)
 - 1.5H = 23”(584mm)
 - 2H = 29”(737mm)
- Separately specified if applicable:
 - Belong Power and communication cabling, tools, screens and tool rails.
 - Storage-to-Panel Bracket
 - Storage Attachment Bracket
 - Ganging Bracket
 - Storage Top (required)
 - Filler Panel
 - Top Filler Track
 - Finished Back (recommended when back is exposed)
 - Adjustable Shelf (not included with unit)
 - Stack-On Hutch
- Refer to Specification Guide for planning information and actual dimensions.

Notes: 2H storage base units are not designed to fit under Reside benching or return worksurfaces. Reside Desking or Adaptable worksurfaces can be attached to the front or back of a 2H Beside storage unit with separately specified flush mount plates.

Separately specified Belong base unit power components available for 30”-72”(372mm-1829mm) widths only.

Storage shelves are unique to the specific base unit configuration. Refer to shelf price list pages for appropriate shelf.

1H units cannot accept binders.

To Order, Specify:

Steel Door Front

- 1) Product number, including:

1 Door Front Option:

S Steel

2 Leg Option:

F Straight Leg

P Chamfer Leg, add **\$85.70** list

3 Lock Option:

L Locking, add **\$42.85** list

N Non-Locking

- 2) Case laminate color.
- 3) Case laminate edgeband color.
- 4) Bottom, inset back and fixed shelf trim color.
- 5) Pull, leg and spacer trim color.
- 6) Door front color.

Laminate or Wood Door Front

- 1) Product number, including:

1 Door Front Option:

L Laminate

W Wood

2 Leg Option:

F Straight Leg

P Chamfer Leg, add **\$85.70** list

3 Lock Option:

L Locking, add **\$42.85** list

N Non-Locking

- 2) Case laminate color.
- 3) Case laminate edgeband color.
- 4) Bottom, inset back and fixed shelf trim color.
- 5) Pull, leg and spacer trim color.
- 6) Door front color.
- 7) Laminate front edgeband color.

Note: Upcharge for mixed grade fabric or trim surfaces, refer to the electronic design and specification tools for pricing.

Base Unit — Double Sliding Door

Description	Finished Height*	Actual Width	Nominal Width	Number	Case Laminate A			Steel Door		Laminate Door		Wood Door	
					①	②	③	Trim A	Trim B	A	B	Group A	Group B
1H													
Sliding Door — Proud Left	17"(432mm)	23 7/8"(606mm)	24"(610mm)	QBDF-1724-PNN	N			\$1181.54	\$1189.04	\$1288.66	\$1331.51	\$1476.12	\$1518.97
		29 7/8"(759mm)	30"(762mm)	QBDF-1730-PNN	N			1239.38	1249.02	1356.14	1402.20	1562.88	1611.09
		35 7/8"(911mm)	36"(914mm)	QBDF-1736-PNN	N			1297.22	1309.00	1423.62	1472.89	1649.64	1703.21
		41 7/8"(1064mm)	42"(1067mm)	QBDF-1742-PNN	N			1355.06	1368.98	1491.10	1543.58	1736.40	1795.33
		47 7/8"(1216mm)	48"(1219mm)	QBDF-1748-PNN	N			1412.90	1428.96	1558.58	1614.27	1823.16	1887.45
		59 7/8"(1521mm)	60"(1524mm)	QBDF-1760-PNN	N			1528.58	1548.92	1693.54	1755.65	1996.68	2071.69
		71 7/8"(1826mm)	72"(1829mm)	QBDF-1772-PNN	N			1644.26	1668.88	1828.50	1897.03	2170.20	2255.93
Sliding Door — Proud Right	17"(432mm)	23 7/8"(606mm)	24"(610mm)	QBDF-1724-QNN	N			\$1181.54	\$1189.04	\$1288.66	\$1331.51	\$1476.12	\$1518.97
		29 7/8"(759mm)	30"(762mm)	QBDF-1730-QNN	N			1239.38	1249.02	1356.14	1402.20	1562.88	1611.09
		35 7/8"(911mm)	36"(914mm)	QBDF-1736-QNN	N			1297.22	1309.00	1423.62	1472.89	1649.64	1703.21
		41 7/8"(1064mm)	42"(1067mm)	QBDF-1742-QNN	N			1355.06	1368.98	1491.10	1543.58	1736.40	1795.33
		47 7/8"(1216mm)	48"(1219mm)	QBDF-1748-QNN	N			1412.90	1428.96	1558.58	1614.27	1823.16	1887.45
		59 7/8"(1521mm)	60"(1524mm)	QBDF-1760-QNN	N			1528.58	1548.92	1693.54	1755.65	1996.68	2071.69
		71 7/8"(1826mm)	72"(1829mm)	QBDF-1772-QNN	N			1644.26	1668.88	1828.50	1897.03	2170.20	2255.93
1.5H													
Sliding Door — Proud Left	23"(584mm)	23 7/8"(606mm)	24"(610mm)	QBDF-2324-PNN	N			\$1312.23	\$1324.01	\$1430.06	\$1472.91	\$1638.95	\$1681.80
		29 7/8"(759mm)	30"(762mm)	QBDF-2330-PNN	N			1423.63	1437.55	1551.10	1597.16	1779.27	1827.48
		35 7/8"(911mm)	36"(914mm)	QBDF-2336-PNN	N			1535.03	1551.09	1672.14	1721.41	1919.59	1973.16
		41 7/8"(1064mm)	42"(1067mm)	QBDF-2342-PNN	N			1646.43	1664.63	1793.18	1845.66	2059.91	2118.84
		47 7/8"(1216mm)	48"(1219mm)	QBDF-2348-PNN	N			1757.83	1778.17	1914.22	1969.91	2200.23	2264.52
		59 7/8"(1521mm)	60"(1524mm)	QBDF-2360-PNN	N			1980.63	2005.25	2156.30	2218.41	2480.87	2555.88
		71 7/8"(1826mm)	72"(1829mm)	QBDF-2372-PNN	N			2203.43	2232.33	2398.38	2466.91	2761.51	2847.24
Sliding Door — Proud Right	23"(584mm)	23 7/8"(606mm)	24"(610mm)	QBDF-2324-QNN	N			\$1312.23	\$1324.01	\$1430.06	\$1472.91	\$1638.95	\$1681.80
		29 7/8"(759mm)	30"(762mm)	QBDF-2330-QNN	N			1423.63	1437.55	1551.10	1597.16	1779.27	1827.48
		35 7/8"(911mm)	36"(914mm)	QBDF-2336-QNN	N			1535.03	1551.09	1672.14	1721.41	1919.59	1973.16
		41 7/8"(1064mm)	42"(1067mm)	QBDF-2342-QNN	N			1646.43	1664.63	1793.18	1845.66	2059.91	2118.84
		47 7/8"(1216mm)	48"(1219mm)	QBDF-2348-QNN	N			1757.83	1778.17	1914.22	1969.91	2200.23	2264.52
		59 7/8"(1521mm)	60"(1524mm)	QBDF-2360-QNN	N			1980.63	2005.25	2156.30	2218.41	2480.87	2555.88
		71 7/8"(1826mm)	72"(1829mm)	QBDF-2372-QNN	N			2203.43	2232.33	2398.38	2466.91	2761.51	2847.24
2H													
Sliding Door — Proud Left	29"(737mm)	23 7/8"(606mm)	24"(610mm)	QBDF-2924-PNN	N			\$1403.28	\$1419.35	\$1531.82	\$1574.67	\$1762.13	\$1804.98
		29 7/8"(759mm)	30"(762mm)	QBDF-2930-PNN	N			1514.68	1532.89	1652.86	1698.92	1902.45	1950.66
		35 7/8"(911mm)	36"(914mm)	QBDF-2936-PNN	N			1626.08	1646.43	1773.90	1823.17	2042.77	2096.34
		41 7/8"(1064mm)	42"(1067mm)	QBDF-2942-PNN	N			1737.48	1759.97	1894.94	1947.42	2183.09	2242.02
		47 7/8"(1216mm)	48"(1219mm)	QBDF-2948-PNN	N			1848.88	1873.51	2015.98	2071.67	2323.41	2387.70
		59 7/8"(1521mm)	60"(1524mm)	QBDF-2960-PNN	N			2071.68	2100.59	2258.06	2320.17	2604.05	2679.06
		71 7/8"(1826mm)	72"(1829mm)	QBDF-2972-PNN	N			2294.48	2327.67	2500.14	2568.67	2884.69	2970.42
Sliding Door — Proud Right	29"(737mm)	23 7/8"(606mm)	24"(610mm)	QBDF-2924-QNN	N			\$1403.28	\$1419.35	\$1531.82	\$1574.67	\$1762.13	\$1804.98
		29 7/8"(759mm)	30"(762mm)	QBDF-2930-QNN	N			1514.68	1532.89	1652.86	1698.92	1902.45	1950.66
		35 7/8"(911mm)	36"(914mm)	QBDF-2936-QNN	N			1626.08	1646.43	1773.90	1823.17	2042.77	2096.34
		41 7/8"(1064mm)	42"(1067mm)	QBDF-2942-QNN	N			1737.48	1759.97	1894.94	1947.42	2183.09	2242.02
		47 7/8"(1216mm)	48"(1219mm)	QBDF-2948-QNN	N			1848.88	1873.51	2015.98	2071.67	2323.41	2387.70
		59 7/8"(1521mm)	60"(1524mm)	QBDF-2960-QNN	N			2071.68	2100.59	2258.06	2320.17	2604.05	2679.06
		71 7/8"(1826mm)	72"(1829mm)	QBDF-2972-QNN	N			2294.48	2327.67	2500.14	2568.67	2884.69	2970.42
1H													
Sliding Door — Center	17"(432mm)	47 7/8"(1216mm)	48"(1219mm)	QBTF-1748-ZRZ	N			\$2085.63	\$2101.69	\$2344.86	\$2451.98	\$2778.70	\$2864.39
		59 7/8"(1521mm)	60"(1524mm)	QBTF-1760-ZRZ	N			2171.33	2191.67	2446.63	2556.96	2907.25	3000.44
		71 7/8"(1826mm)	72"(1829mm)	QBTF-1772-ZRZ	N			2257.03	2281.65	2548.40	2661.94	3035.80	3136.49
1.5H													
Sliding Door — Center	23"(584mm)	47 7/8"(1216mm)	48"(1219mm)	QBTF-2348-ZRZ	N			\$2216.31	\$2236.65	\$2475.54	\$2582.66	\$2909.38	\$2995.07
		59 7/8"(1521mm)	60"(1524mm)	QBTF-2360-ZRZ	N			2293.43	2318.05	2568.73	2679.06	3029.35	3122.54
		71 7/8"(1826mm)	72"(1829mm)	QBTF-2372-ZRZ	N			2370.55	2399.45	2661.92	2775.46	3149.32	3250.01

*Finished height is for fully assembled base unit including separately specified top.

Base Unit — Double Sliding Door

Description	Finished Height*	Actual Width	Nominal Width	Number	Case Laminate B			Steel Door		Laminate Door		Wood Door	
					①	②	③	Trim A	Trim B	A	B	Group A	Group B
1H													
Sliding Door — Proud Left	17"(432mm)	23 7/8"(606mm)	24"(610mm)	QBDF-1724-PNN	N			\$1223.32	\$1230.82	\$1330.44	\$1373.29	\$1517.90	\$1560.75
		29 7/8"(759mm)	30"(762mm)	QBDF-1730-PNN	N			1283.30	1292.94	1400.06	1446.12	1606.80	1655.01
		35 7/8"(911mm)	36"(914mm)	QBDF-1736-PNN	N			1343.28	1355.06	1469.68	1518.95	1695.70	1749.27
		41 7/8"(1064mm)	42"(1067mm)	QBDF-1742-PNN	N			1403.26	1417.18	1539.30	1591.78	1784.60	1843.53
		47 7/8"(1216mm)	48"(1219mm)	QBDF-1748-PNN	N			1463.24	1479.30	1608.92	1664.61	1873.50	1937.79
		59 7/8"(1521mm)	60"(1524mm)	QBDF-1760-PNN	N			1583.20	1603.54	1748.16	1810.27	2051.30	2126.31
		71 7/8"(1826mm)	72"(1829mm)	QBDF-1772-PNN	N			1703.16	1727.78	1887.40	1955.93	2229.10	2314.83
Sliding Door — Proud Right	17"(432mm)	23 7/8"(606mm)	24"(610mm)	QBDF-1724-QNN	N			\$1223.32	\$1230.82	\$1330.44	\$1373.29	\$1517.90	\$1560.75
		29 7/8"(759mm)	30"(762mm)	QBDF-1730-QNN	N			1283.30	1292.94	1400.06	1446.12	1606.80	1655.01
		35 7/8"(911mm)	36"(914mm)	QBDF-1736-QNN	N			1343.28	1355.06	1469.68	1518.95	1695.70	1749.27
		41 7/8"(1064mm)	42"(1067mm)	QBDF-1742-QNN	N			1403.26	1417.18	1539.30	1591.78	1784.60	1843.53
		47 7/8"(1216mm)	48"(1219mm)	QBDF-1748-QNN	N			1463.24	1479.30	1608.92	1664.61	1873.50	1937.79
		59 7/8"(1521mm)	60"(1524mm)	QBDF-1760-QNN	N			1583.20	1603.54	1748.16	1810.27	2051.30	2126.31
		71 7/8"(1826mm)	72"(1829mm)	QBDF-1772-QNN	N			1703.16	1727.78	1887.40	1955.93	2229.10	2314.83
1.5H													
Sliding Door — Proud Left	23"(584mm)	23 7/8"(606mm)	24"(610mm)	QBDF-2324-PNN	N			\$1360.43	\$1372.21	\$1478.26	\$1521.11	\$1687.15	\$1730.00
		29 7/8"(759mm)	30"(762mm)	QBDF-2330-PNN	N			1473.97	1487.89	1601.44	1647.50	1829.61	1877.82
		35 7/8"(911mm)	36"(914mm)	QBDF-2336-PNN	N			1587.51	1603.57	1724.62	1773.89	1972.07	2025.64
		41 7/8"(1064mm)	42"(1067mm)	QBDF-2342-PNN	N			1701.05	1719.25	1847.80	1900.28	2114.53	2173.46
		47 7/8"(1216mm)	48"(1219mm)	QBDF-2348-PNN	N			1814.59	1834.93	1970.98	2026.67	2256.99	2321.28
		59 7/8"(1521mm)	60"(1524mm)	QBDF-2360-PNN	N			2041.67	2066.29	2217.34	2279.45	2541.91	2616.92
		71 7/8"(1826mm)	72"(1829mm)	QBDF-2372-PNN	N			2268.75	2297.65	2463.70	2532.23	2826.83	2912.56
Sliding Door — Proud Right	23"(584mm)	23 7/8"(606mm)	24"(610mm)	QBDF-2324-QNN	N			\$1360.43	\$1372.21	\$1478.26	\$1521.11	\$1687.15	\$1730.00
		29 7/8"(759mm)	30"(762mm)	QBDF-2330-QNN	N			1473.97	1487.89	1601.44	1647.50	1829.61	1877.82
		35 7/8"(911mm)	36"(914mm)	QBDF-2336-QNN	N			1587.51	1603.57	1724.62	1773.89	1972.07	2025.64
		41 7/8"(1064mm)	42"(1067mm)	QBDF-2342-QNN	N			1701.05	1719.25	1847.80	1900.28	2114.53	2173.46
		47 7/8"(1216mm)	48"(1219mm)	QBDF-2348-QNN	N			1814.59	1834.93	1970.98	2026.67	2256.99	2321.28
		59 7/8"(1521mm)	60"(1524mm)	QBDF-2360-QNN	N			2041.67	2066.29	2217.34	2279.45	2541.91	2616.92
		71 7/8"(1826mm)	72"(1829mm)	QBDF-2372-QNN	N			2268.75	2297.65	2463.70	2532.23	2826.83	2912.56
2H													
Sliding Door — Proud Left	29"(737mm)	23 7/8"(606mm)	24"(610mm)	QBDF-2924-PNN	N			\$1457.91	\$1473.98	\$1586.45	\$1629.30	\$1816.76	\$1859.61
		29 7/8"(759mm)	30"(762mm)	QBDF-2930-PNN	N			1571.45	1589.66	1709.63	1755.69	1959.22	2007.43
		35 7/8"(911mm)	36"(914mm)	QBDF-2936-PNN	N			1684.99	1705.34	1832.81	1882.08	2101.68	2155.25
		41 7/8"(1064mm)	42"(1067mm)	QBDF-2942-PNN	N			1798.53	1821.02	1955.99	2008.47	2244.14	2303.07
		47 7/8"(1216mm)	48"(1219mm)	QBDF-2948-PNN	N			1912.07	1936.70	2079.17	2134.86	2386.60	2450.89
		59 7/8"(1521mm)	60"(1524mm)	QBDF-2960-PNN	N			2139.15	2168.06	2325.53	2387.64	2671.52	2746.53
		71 7/8"(1826mm)	72"(1829mm)	QBDF-2972-PNN	N			2366.23	2399.42	2571.89	2640.42	2956.44	3042.17
Sliding Door — Proud Right	29"(737mm)	23 7/8"(606mm)	24"(610mm)	QBDF-2924-QNN	N			\$1457.91	\$1473.98	\$1586.45	\$1629.30	\$1816.76	\$1859.61
		29 7/8"(759mm)	30"(762mm)	QBDF-2930-QNN	N			1571.45	1589.66	1709.63	1755.69	1959.22	2007.43
		35 7/8"(911mm)	36"(914mm)	QBDF-2936-QNN	N			1684.99	1705.34	1832.81	1882.08	2101.68	2155.25
		41 7/8"(1064mm)	42"(1067mm)	QBDF-2942-QNN	N			1798.53	1821.02	1955.99	2008.47	2244.14	2303.07
		47 7/8"(1216mm)	48"(1219mm)	QBDF-2948-QNN	N			1912.07	1936.70	2079.17	2134.86	2386.60	2450.89
		59 7/8"(1521mm)	60"(1524mm)	QBDF-2960-QNN	N			2139.15	2168.06	2325.53	2387.64	2671.52	2746.53
		71 7/8"(1826mm)	72"(1829mm)	QBDF-2972-QNN	N			2366.23	2399.42	2571.89	2640.42	2956.44	3042.17
1H													
Sliding Door — Center	17"(432mm)	47 7/8"(1216mm)	48"(1219mm)	QBTF-1748-ZRZ	N			\$2135.97	\$2152.03	\$2395.20	\$2502.32	\$2829.04	\$2914.73
		59 7/8"(1521mm)	60"(1524mm)	QBTF-1760-ZRZ	N			2225.95	2246.29	2501.25	2611.58	2961.87	3055.06
		71 7/8"(1826mm)	72"(1829mm)	QBTF-1772-ZRZ	N			2315.93	2340.55	2607.30	2720.84	3094.70	3195.39
1.5H													
Sliding Door — Center	23"(584mm)	47 7/8"(1216mm)	48"(1219mm)	QBTF-2348-ZRZ	N			\$2273.07	\$2293.41	\$2532.30	\$2639.42	\$2966.14	\$3051.83
		59 7/8"(1521mm)	60"(1524mm)	QBTF-2360-ZRZ	N			2354.47	2379.09	2629.77	2740.10	3090.39	3183.58
		71 7/8"(1826mm)	72"(1829mm)	QBTF-2372-ZRZ	N			2435.87	2464.77	2727.24	2840.78	3214.64	3315.33

*Finished height is for fully assembled base unit including separately specified top.

Storage Top

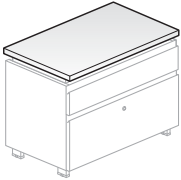
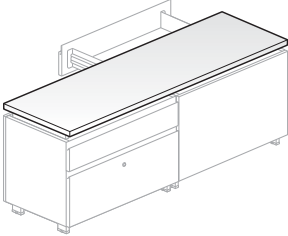
	Nominal Depth	Actual Width	Nominal Width	Number ① ②	Laminate		Wood Group			
					A	B	A	B		
	18"(457mm)	23 7/8"(606mm)	24"(610mm)	QBRA-1824-■ ■ S	\$174.61	\$234.60	\$374.92	\$ 610.58		
		29 7/8"(759mm)	30"(762mm)	QBRA-1830-■ ■ S	189.61	249.60	389.92	642.72		
		35 7/8"(911mm)	36"(914mm)	QBRA-1836-■ ■ S	204.61	264.60	404.92	674.86		
		41 7/8"(1064mm)	42"(1067mm)	QBRA-1842-■ ■ S	219.61	279.60	419.92	707.00		
		47 7/8"(1216mm)	48"(1219mm)	QBRA-1848-■ ■ S	234.61	294.60	434.92	739.14		
		53 7/8"(1368mm)	54"(1372mm)	QBRA-1854-■ ■ S	249.61	309.60	449.92	771.28		
		59 7/8"(1521mm)	60"(1524mm)	QBRA-1860-■ ■ S	264.61	324.60	464.92	803.42		
		65 7/8"(1673mm)	66"(1676mm)	QBRA-1866-■ ■ S	279.61	339.60	479.92	835.56		
		71 7/8"(1826mm)	72"(1829mm)	QBRA-1872-■ ■ S	294.61	354.60	494.92	867.70		
		77 7/8"(1978mm)	78"(1981mm)	QBRA-1878-■ ■ S	309.61	369.60	509.92	899.84		
		83 7/8"(2130mm)	84"(2134mm)	QBRA-1884-■ ■ S	324.61	384.60	524.92	931.98		
		89 7/8"(2283mm)	90"(2286mm)	QBRA-1890-■ ■ S	339.61	399.60	539.92	964.12		
		95 7/8"(2435mm)	96"(2438mm)	QBRA-1896-■ ■ S	354.61	414.60	554.92	996.26		
		101 7/8"(2588mm)	102"(2591mm)	QBRA-18A2-■ ■ S	369.61	429.60	569.92	1028.40		
		107 7/8"(2740mm)	108"(2743mm)	QBRA-18A8-■ ■ S	384.61	444.60	584.92	1060.54		
		113 7/8"(2892mm)	114"(2896mm)	QBRA-18B4-■ ■ S	399.61	459.60	599.92	1092.68		
		119 7/8"(3045mm)	120"(3048mm)	QBRA-18C0-■ ■ S	414.61	474.60	614.92	1124.82		
			36"(914mm)	23 7/8"(606mm)	24"(610mm)	QBRA-3624-■ ■ S	174.61	234.60	374.92	610.58
				29 7/8"(759mm)	30"(762mm)	QBRA-3630-■ ■ S	189.61	249.60	389.92	642.72
				35 7/8"(911mm)	36"(914mm)	QBRA-3636-■ ■ S	204.61	264.60	404.92	674.86
41 7/8"(1064mm)	42"(1067mm)			QBRA-3642-■ ■ S	219.61	279.60	419.92	707.00		
47 7/8"(1216mm)	48"(1219mm)			QBRA-3648-■ ■ S	234.61	294.60	434.92	739.14		
53 7/8"(1368mm)	54"(1372mm)			QBRA-3654-■ ■ S	249.61	309.60	449.92	771.28		
59 7/8"(1521mm)	60"(1524mm)			QBRA-3660-■ ■ S	264.61	324.60	464.92	803.42		
65 7/8"(1673mm)	66"(1676mm)			QBRA-3666-■ ■ S	279.61	339.60	479.92	835.56		
71 7/8"(1826mm)	72"(1829mm)			QBRA-3672-■ ■ S	294.61	354.60	494.92	867.70		
77 7/8"(1978mm)	78"(1981mm)			QBRA-3678-■ ■ S	309.61	369.60	509.92	899.84		
83 7/8"(2130mm)	84"(2134mm)			QBRA-3684-■ ■ S	324.61	384.60	524.92	931.98		
89 7/8"(2283mm)	90"(2286mm)			QBRA-3690-■ ■ S	339.61	399.60	539.92	964.12		
95 7/8"(2435mm)	96"(2438mm)			QBRA-3696-■ ■ S	354.61	414.60	554.92	996.26		
101 7/8"(2588mm)	102"(2591mm)			QBRA-36A2-■ ■ S	369.61	429.60	569.92	1028.40		
107 7/8"(2740mm)	108"(2743mm)			QBRA-36A8-■ ■ S	384.61	444.60	584.92	1060.54		
113 7/8"(2892mm)	114"(2896mm)			QBRA-36B4-■ ■ S	399.61	459.60	599.92	1092.68		
119 7/8"(3045mm)	120"(3048mm)			QBRA-36C0-■ ■ S	414.61	474.60	614.92	1124.82		

QBRA

Features

- Includes 1-3/16"(30mm) thick Individual Storage Top and attachment hardware.
- Available in laminate or wood veneer:
 - Laminate surface with 3mm edge- band on front and back edge; 1mm edgeband on sides.
 - Wood veneer surface with 3mm wood edgeband on front and back; 1mm wood edgeband on sides.
- For use with storage applications with inset unfinished back or separately specified proud finished back. If finished back is not specified; top will extend 3/4"(19mm) past the back of the unit.

Specification Tips

- Dimensioned for use with Beside Storage only.
- Separately specified storage tops are required and can match the width of a single base unit or span two or more adjacent base units side by side.**
- Tops must be drilled to install field installed Powertap brackets with grommets.
- Tops must be field drilled to attach Stanchion Kits.
- Tops required on 1H, 1.5H and 2H storage units.
- Refer to Specification Guide for planning information and actual dimensions.

To Order, Specify:

- Product number, including:

① Material Option:

L Laminate

W Wood

② Edgeband Option:

J Edgeband

K Wood Edgeband

- Laminate color.

- Laminate edgeband color.

Finished Back

Description	Finished Height	Actual Width	Nominal Width	Number ①	Steel		Laminate		Wood Group	
					Trim A	Trim B	A	B	A	B
1H										
	17"(432mm)	23 7/8"(606mm)	24"(610mm)	QBBK-1724-	\$ 95.34	\$100.70	\$109.27	\$169.26	\$133.90	\$137.11
		29 7/8"(759mm)	30"(762mm)	QBBK-1730-	113.55	118.91	127.48	187.47	152.11	156.39
		35 7/8"(911mm)	36"(914mm)	QBBK-1736-	131.76	137.12	145.69	205.68	170.32	175.67
		41 7/8"(1064mm)	42"(1067mm)	QBBK-1742-	149.97	155.33	163.90	223.89	188.53	194.95
		47 7/8"(1216mm)	48"(1219mm)	QBBK-1748-	168.18	173.54	182.11	242.10	206.74	214.23
		59 7/8"(1521mm)	60"(1524mm)	QBBK-1760-	204.60	209.96	218.53	278.52	243.16	252.79
		71 7/8"(1826mm)	72"(1829mm)	QBBK-1772-	241.02	246.38	254.95	314.94	279.58	291.35
1.5H										
	23"(584mm)	23 7/8"(606mm)	24"(610mm)	QBBK-2324-	\$106.05	\$111.41	\$119.98	\$179.97	\$144.61	\$147.82
		29 7/8"(759mm)	30"(762mm)	QBBK-2330-	124.26	129.62	138.19	198.18	162.82	167.10
		35 7/8"(911mm)	36"(914mm)	QBBK-2336-	142.47	147.83	156.40	216.39	181.03	186.38
		41 7/8"(1064mm)	42"(1067mm)	QBBK-2342-	160.68	166.04	174.61	234.60	199.24	205.66
		47 7/8"(1216mm)	48"(1219mm)	QBBK-2348-	178.89	184.25	192.82	252.81	217.45	224.94
		59 7/8"(1521mm)	60"(1524mm)	QBBK-2360-	215.31	220.67	229.24	289.23	253.87	263.50
		71 7/8"(1826mm)	72"(1829mm)	QBBK-2372-	251.73	257.09	265.66	325.65	290.29	302.06
2H										
	29"(737mm)	23 7/8"(606mm)	24"(610mm)	QBBK-2924-	\$116.76	\$122.12	\$130.69	\$190.68	\$155.32	\$158.53
		29 7/8"(759mm)	30"(762mm)	QBBK-2930-	134.97	140.33	148.90	208.89	173.53	177.81
		35 7/8"(911mm)	36"(914mm)	QBBK-2936-	153.18	158.54	167.11	227.10	191.74	197.09
		41 7/8"(1064mm)	42"(1067mm)	QBBK-2942-	171.39	176.75	185.32	245.31	209.95	216.37
		47 7/8"(1216mm)	48"(1219mm)	QBBK-2948-	189.60	194.96	203.53	263.52	228.16	235.65
		59 7/8"(1521mm)	60"(1524mm)	QBBK-2960-	226.02	231.38	239.95	299.94	264.58	274.21
		71 7/8"(1826mm)	72"(1829mm)	QBBK-2972-	262.44	267.80	276.37	336.36	301.00	312.77

Finished Back

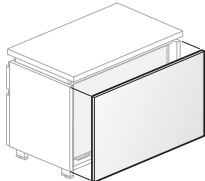

QBBK

Features

- Includes 3/4"(19mm) thick finished back and attachment hardware.
- For use with one Beside base storage unit, not designed to span multiple units.
- Field installed.

Specification Tips

- Provides a finished back panel in an exposed Beside storage back application.
- Provides a finished back in a Beside storage supported convergent worksurface application.
- Finished Back adds 3/4"(19mm) to depth of the unfinished inset back storage unit.
- Refer to Specification Guide for planning information and actual dimensions.

To Order, Specify:

- 1) Product number, including:

① Material Option:

- S** Steel
- L** Laminate
- W** Wood

- 2) Steel, laminate, or wood color.
- 3) Laminate edgeband color.

Accessories — Base Unit Accessory Shelf

	Base Unit Nominal Width	Shelf Actual Width	Number	Trim A	B
Single Units — Open and Functional	24"(610mm)	22.32"(567mm)	QASS-24-BNS	\$113.55	\$118.91
	30"(762mm)	28.32"(719mm)	QASS-30-BNS	117.85	123.21
	36"(914mm)	34.32"(872mm)	QASS-36-BNS	122.12	127.48
	42"(1067mm)	40.32"(1024mm)	QASS-42-BNS	126.41	131.77

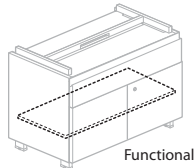
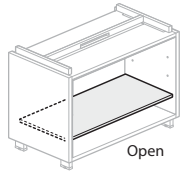

QASS

Feature

- Includes 5/8"(16mm) thick painted steel shelf and shelf pins.

Specification Tips

- Shelf is designed for use with Beside base units only.
- Open and functional interior dimensions/shelf widths are specific to Beside base unit configurations.
- Refer to Specification Guide for planning guidelines and actual dimensions.

Note: When ordering, first determine the type of unit (open or functional), the location of shelf, then determine shelf size.

To Order, Specify:

- Product number.
- Trim color.

	Base Unit Nominal Width	Shelf Actual Width	Number	Trim A	B
Double Units — Open/Open	48"(1219mm)	22.75"(578mm)	QASD-24-ONS	\$113.53	\$127.46
	60"(1524mm)	28.75"(730mm)	QASD-30-ONS	122.09	136.02
	72"(1829mm)	34.75"(883mm)	QASD-36-ONS	130.65	144.58

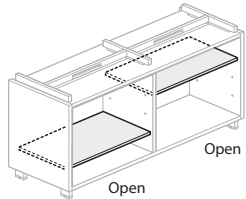

QASD

Feature

- Includes 5/8"(16mm) thick painted steel shelf and shelf pins.

Specification Tips

- Shelf is designed for use with Beside base units only.
- Open and functional interior dimensions/shelf widths are specific to Beside base unit configurations.
- Refer to Specification Guide for planning guidelines and actual dimensions.

Note: When ordering, first determine the type of unit (open or functional), the location of shelf, then determine shelf size.

To Order, Specify:

- Product number.
- Trim color.

	Base Unit Nominal Width	Shelf Actual Width	Number	Trim A	B	
Double Units — Open/Functional	Open Side	48"(1219mm)	23.06"(586mm)	QASD-24-XNS	\$113.53	\$127.46
		60"(1524mm)	29.06"(738mm)	QASD-30-XNS	122.09	136.02
		72"(1829mm)	35.06"(891mm)	QASD-36-XNS	130.65	144.58
	Functional Side	48"(1219mm)	22.32"(567mm)	QASS-24-BNS	\$113.55	\$118.91
		60"(1524mm)	28.32"(719mm)	QASS-30-BNS	117.85	123.21
		72"(1829mm)	34.32"(872mm)	QASS-36-BNS	122.12	127.48

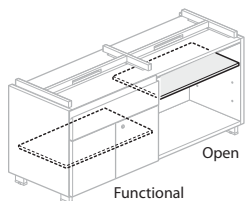

QASD

Feature

- Includes 5/8"(16mm) thick painted steel shelf and shelf pins.

Specification Tips

- Shelf is designed for use with Beside base units only.
- Open and functional interior dimensions/shelf widths are specific to Beside base unit configurations.
- Refer to Specification Guide for planning guidelines and actual dimensions.

Note: When ordering, first determine the type of unit (open or functional), the location of shelf, then determine shelf size.

To Order, Specify:

- Product number.
- Trim color.

Accessories — Base Unit Accessory Shelf

Single Sliding Door

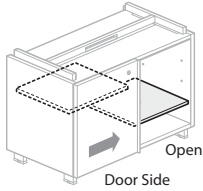

QASD

Description	Base Unit Nominal Width	Shelf Actual Width	Number	Trim	
				A	B
Door Side 24"-42"(610mm-1067mm)	24"(610mm)	11.06"(281mm)	QASD-12-FNS	\$ 96.41	\$110.34
	30"(762mm)	14.06"(357mm)	QASD-15-FNS	100.69	114.62
	36"(914mm)	17.06"(433mm)	QASD-18-FNS	104.97	118.90
	42"(1067mm)	20.06"(510mm)	QASD-21-FNS	109.25	123.18
Door Side 48"-72"(1219mm-1829mm)	48"(1219mm)	22.32"(567mm)	QASS-24-BNS	\$113.55	\$118.91
	60"(1524mm)	28.32"(719mm)	QASS-30-BNS	117.85	123.21
	72"(1829mm)	34.32"(872mm)	QASS-36-BNS	122.12	127.48
Open Side 24"-72"(610mm-1829mm)	24"(610mm)	11.06"(281mm)	QASD-12-XNS	\$ 96.41	\$110.34
	30"(762mm)	14.06"(357mm)	QASD-15-XNS	100.69	114.62
	36"(914mm)	17.06"(433mm)	QASD-18-XNS	104.97	118.90
	42"(1067mm)	20.06"(510mm)	QASD-21-XNS	109.25	123.18
	48"(1219mm)	23.06"(586mm)	QASD-24-XNS	113.53	127.46
	60"(1524mm)	29.06"(738mm)	QASD-30-XNS	122.09	136.02
72"(1829mm)	35.06"(891mm)	QASD-36-XNS	130.65	144.58	

Feature

- Includes 5/8"(16mm) thick painted steel shelf and shelf pins.

Specification Tips

- Shelf is designed for use with Beside base units only.
- Open and functional interior dimensions/shelf widths are specific to Beside base unit configurations.
- Refer to Specification Guide for planning guidelines and actual dimensions.

Note: When ordering, first determine the type of unit (open or functional), the location of shelf, then determine shelf size.

To Order, Specify:

- Product number.
- Trim color.

Double Sliding Door

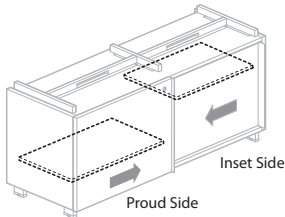

QASR

Proud Side 24"-42"(610mm-1067mm)	24"(610mm)	10.32"(262mm)	QASP-12-FNS	\$ 96.41	\$110.34
	30"(762mm)	13.32"(338mm)	QASP-15-FNS	100.69	114.62
	36"(914mm)	16.32"(415mm)	QASP-18-FNS	104.97	118.90
	42"(1067mm)	19.32"(491mm)	QASP-21-FNS	109.25	123.18
Proud Side 48"-72"(1219mm-1829mm)	48"(1219mm)	22.32"(567mm)	QASP-24-FNS	\$113.53	\$127.46
	60"(1524mm)	28.32"(719mm)	QASP-30-FNS	122.09	136.02
	72"(1829mm)	34.32"(872mm)	QASP-36-FNS	130.65	144.58
Inset Side 24"-42"(610mm-1067mm)	24"(610mm)	11.06"(281mm)	QASR-12-FNS	\$ 96.41	\$110.34
	30"(762mm)	14.06"(357mm)	QASR-15-FNS	100.69	114.62
	36"(914mm)	17.06"(433mm)	QASR-18-FNS	104.97	118.90
	42"(1067mm)	20.06"(510mm)	QASR-21-FNS	109.25	123.18
Inset Side 48"-72"(610mm-1829mm)	48"(1219mm)	23.06"(586mm)	QASR-24-FNS	\$113.53	\$127.46
	60"(1524mm)	29.06"(738mm)	QASR-30-FNS	122.09	136.02
	72"(1829mm)	35.06"(891mm)	QASR-36-FNS	130.65	144.58

Feature

- Includes 5/8"(16mm) thick painted steel shelf and shelf pins.

Specification Tips

- Shelf is designed for use with Beside base units only.
- Open and functional interior dimensions/shelf widths are specific to Beside base unit configurations.
- Refer to Specification Guide for planning guidelines and actual dimensions.

Note: When ordering, first determine the type of unit (open or functional), the location of shelf, then determine shelf size.

To Order, Specify:

- Product number.
- Trim color.

Accessories — Base Unit Accessory Shelf

Triple Unit

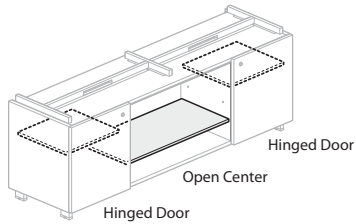
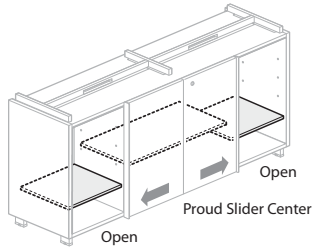
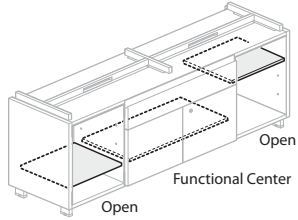

QAST

Description	Base Unit Nominal Width	Shelf Actual Width	Number	Trim	
				A	B
Functional/Proud Center Slider					
Center	48"(1219mm)	22.32"(567mm)	QASS-24-BNS	\$113.55	\$118.91
	60"(1524mm)	28.32"(719mm)	QASS-30-BNS	117.85	123.21
	72"(1829mm)	34.32"(872mm)	QASS-36-BNS	122.12	127.48
Wings (Open or hinged Door)	48"(1219mm)	11.06"(281mm)	QAST-12-FFS	\$ 97.38	\$102.74
	60"(1524mm)	14.06"(357mm)	QAST-15-FFS	100.66	106.02
	72"(1829mm)	17.06"(433mm)	QAST-18-FFS	103.90	109.26
Open Center					
Center	48"(1219mm)	23.91"(607mm)	QAST-24-XNS	\$110.37	\$115.73
	60"(1524mm)	29.91"(760mm)	QAST-30-XNS	116.88	122.24
	72"(1829mm)	35.91"(912mm)	QAST-36-XNS	123.36	128.72
Wings (Hinged Door)	48"(1219mm)	10.45"(265mm)	QAST-12-FOS	\$ 97.38	\$102.74
	60"(1524mm)	13.45"(342mm)	QAST-15-FOS	100.66	106.02
	72"(1829mm)	16.45"(418mm)	QAST-18-FOS	103.90	109.26

Feature

- Includes 5/8"(16mm) thick painted steel shelf and shelf pins.

Specification Tips

- Shelf is designed for use with Beside base units only.
- Open and functional interior dimensions/shelf widths are specific to Beside base unit configurations.
- Refer to Specification Guide for planning guidelines and actual dimensions.

Note: When ordering, first determine the type of unit (open or functional), the location of shelf, then determine shelf size.

To Order, Specify:

- Product number.
- Trim color.

Accessories

Filler Panel

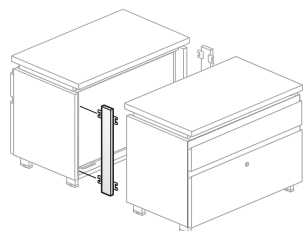

QAFF

Description	Gap	Number	Laminate	
			A	B
1H				
	1.5"(38mm)	QAFF-0017-AL	\$106.05	\$114.54
	2.8"(71mm)	QAFF-0017-BL	109.26	118.01
	5.1"(130mm)	QAFF-0017-CL	112.48	121.49
1.5H				
	1.5"(38mm)	QAFF-0023-AL	\$109.26	\$117.75
	2.8"(71mm)	QAFF-0023-BL	112.47	121.22
	5.1"(130mm)	QAFF-0023-CL	115.69	124.70
2H				
	1.5"(38mm)	QAFF-0029-AL	\$112.48	\$120.97
	2.8"(71mm)	QAFF-0029-BL	115.69	124.44
	5.1"(130mm)	QAFF-0029-CL	118.91	127.92

Features

- Includes one non-handed, laminate filler panel and attachment hardware.
- Beside Filler Panels are used to fill the open vertical gap between back-to-back base units; available in three depths and heights to accommodate specific applications.
 - **1.5"(38mm)** depth fills the gap between two back-to-back Beside base units with separately specified storage tops.
 - **2.8"(71mm)** depth fills the gap between two back-to-back Beside base units with separately specified storage tops and one of the following component options: a Tool Rail, a Center Screen or a Top Feed.
 - **5.1"(130mm)** depth fills the gap between two back-to-back Beside base units with separately specified storage tops, (2) Tools Rails and a Center Screen.

To Order, Specify:

- 1) Product number.
- 2) Laminate color.
- 3) Laminate edgiband.

Specification Tips

- Separately specified ganging bracket required for back-to-back applications.
- Beside base unit storage with drawer applications.
- Order appropriate quantity for application.
- Not for use with finished backs.
- Refer to Specification Guide for planning information.

Notes: These filler panels are not a Beside base unit attachment option for storage support.

Filler panel does not gang units together. Order separately specified ganging bracket for stability.

Top Filler Track

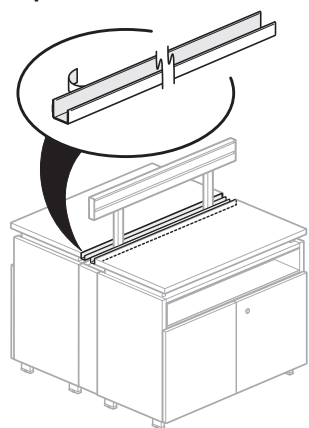

9060-8803

Width	Nominal Depth	Number	Price
72"(1829mm)	1"(25mm)	9060-8803	\$341.71

Features

- Includes (6) 72"(1829mm) plastic filler tracks.
- Tracks attach to Beside storage tops in back-to-back applications when screens or tool rails are used.
- Filler track lessens, but does not fully enclose the top gap.
- Track is field cut to desired width.
- Attaches with double sided tape.
- Available in black only.

To Order, Specify:

- 1) Product number.
(No finish specification required.)

Accessories

Storage to Panel Bracket	Finished Height	Number	Trim		
			A	B	
UniGroup Too					
	17"(432mm)	ZEBQ-1700-P	J	\$157.47	\$166.04
	23"(584mm)	ZEBQ-2300-P	J	157.47	166.04
	29"(737mm)	ZEBQ-2900-P	J	157.47	166.04
Compose					
	17"(432mm)	ZZBQ-1700-P	J	\$157.47	\$166.04
	23"(584mm)	ZZBQ-2300-P	J	157.47	166.04
	29"(737mm)	ZZBQ-2900-P	J	157.47	166.04
PREMISE					
	17"(432mm)	ZNBQ-1700-P	J	\$157.47	\$166.04
	23"(584mm)	ZNBQ-2300-P	J	157.47	166.04
	29"(737mm)	ZNBQ-2900-P	J	157.47	166.04

Left-Hand bracket
Parallel application
Z()BQ-LA

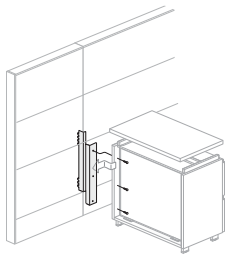

Right-Hand bracket
Perpendicular application
Z()BQ-RE

Features

- Includes one handed application specific attachment bracket with hardware.
- Installs in panel connector slots and attaches to the back corner of the base unit.
- Available in user specified trim colors.

Specification Tips

- Specify the bracket for use with the appropriate panel system; Compose, PREMISE or UniGroup Too, UniGroup and PLACES.
- Height of the bracket is determined by the finished height of the Beside base unit:
 - 17"(432mm) high bracket is for use with a 1H base unit
 - 23"(584mm) high bracket is for use with a 1.5H base unit
 - 29"(737mm) high bracket is for use with a 2H base unit
- Bracket handedness is determined by facing the front of the Beside base unit and identifying if the left or right hand side will attach to the panel.
- Bracket application is determined by the base unit in relationship to the panel run; whether the base unit is parallel or perpendicular to the panel run.
- 2H Beside Base Unit, Storage-to-Panel Bracket and the Adaptable Anti-Dislodgement Clip are separately specified. Used together they provide anti-dislodgement support. Refer to the appropriate panel system Specification Guide for application guidelines.

To Order, Specify:

- 1) Product number, including:

① Handed Option:

- L Left
- R Right

② Application:

- A Parallel
- E Perpendicular

- 2) Trim color.

Adaptable Anti-Dislodgement Clip Kit

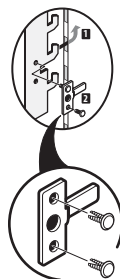

ZZBC

Adaptable Anti-Dislodgement Clip Kit	Number	Price
	ZZBC-0000	\$50.13

Features

- Includes one non-handed attachment plate and two clips.
- For use with 2H Beside Base Unit with Beside Storage- to-Panel Bracket.
- Standard in black finish only.

Specification Tip

- 2H Base Unit, Storage-to-Panel Bracket and the Adaptable Anti-Dislodgement Clip Kit are separately specified. Used together they provide anti-dislodgement support. Refer to the appropriate panel system Specification Guide for application guidelines.

To Order, Specify:

- 1) Product number.
(No finish specification required.)

Accessories

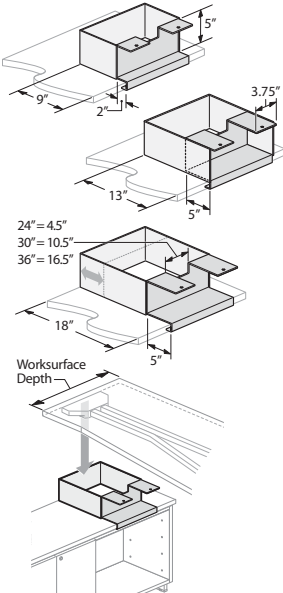
	For Use With	Bracket Width	Number	Trim A	B
Desk-to-Storage Bracket 	Half Cover — 9"(229mm)				
	24" Deep Desking Worksurface	12"(305mm)	ZUBG-2924-PNHC	\$ 94.53	\$ 99.78
	30" Deep Desking Worksurface	18"(457mm)	ZUBG-2930-PNHC	94.53	99.78
	36" Deep Desking Worksurface	24"(610mm)	ZUBG-2936-PNHC	94.53	99.78
	Full Cover — 13"/18"(330mm/457mm)				
	24" Deep Desking Worksurface	12"(305mm)	ZUBG-2924-PNFC	\$115.54	\$120.79
30" Deep Desking Worksurface	18"(457mm)	ZUBG-2930-PNFC	115.54	120.79	
36" Deep Desking Worksurface	24"(610mm)	ZUBG-2936-PNFC	115.54	120.79	

Features

- Includes one desk-to-storage bracket with cover and attachment hardware.
- Bracket height: 5"(127mm).
- Depths are shown in nominal dimensions.
- Cover Options:
 - Half Cover depth is 9"(229mm) deep with 2"(51mm) recess.
 - Full Cover depth is adjustable from 13"-18"(330mm-457mm) deep with a 5"(127mm) recess.

To Order, Specify:

- 1) Product number.
- 2) Trim color.

Specification Tips

- For supporting Reside desking with finished height of 29"(737mm) on Beside one and one-half high storage.
 - Half cover is used to layer Reside above the Beside storage at half depth of 9"(229mm).
 - Full cover used to layer Reside above the Beside storage inside the Beside hutch 13"(330mm) or at full depth 18"(457mm).
- Provides support for one end of Reside desking with central block.
- Desk-to-Storage bracket connects to front or back of Beside storage.
- Desk-to-Storage bracket with half cover supports floating top overhang of 9"(229mm).
- Desk-to-Storage bracket with full cover supports floating top overhang of 13"-18"(330mm-457mm).
- Refer to Specification Guide for planning information and actual dimensions.

ZUBG-PNHC
ZUBG-PNFC

Class PT – SIN 711-2;
Discount Group IX

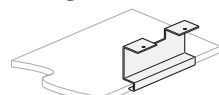
Storage Attachment Bracket

ZUBG-PNNN

Class PT – SIN 711-2;
Discount Group IX

12"(305mm)

ZUBG-2900-PNNN

\$63.02

\$68.27

Feature

- Includes one storage attachment bracket and attachment hardware.
- Bracket height 5"(127mm) with 2"(51mm) recess.

To Order, Specify:

- 1) Produce number.
- 2) Trim color.

Specification Tips

- Used to attach a freestanding 1.5H Beside storage base unit with a storage top.
- Refer to Specification Guide for planning information and actual dimensions.

Note: The storage attachment bracket does not provide Reside Worksurface Support.

Flush Mount Plate

ZUBF-PN

Class CA – SIN 711-1;
Discount Group I

Depth

3"(76mm)

Width

4"(102mm)

Number

ZUBF-0000-PN

Price

\$22.73

Features

- Includes one bracket and mounting screws.
- Standard in Charcoal finish.

To Order, Specify:

- 1) Product number.
(No finish specification required.)

Specification Tips

- Provides attachment for perpendicular desking worksurfaces.
- Used to attach Reside desking or Adaptable worksurface along depth side to front or back edge of Storage Top at a nominal finished height of 29"(737mm).
- Two plates are required.
- Refer to Specification Guide for planning information and actual dimensions.

Accessories

Ganging Bracket Kit

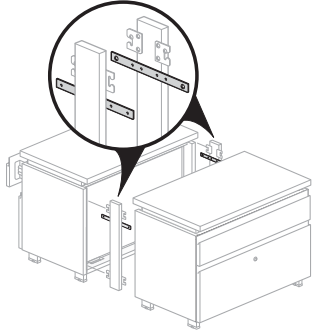

QAGB
(Two kits required for this application)

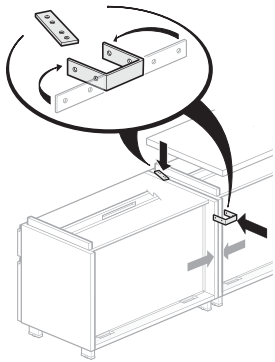

Front-to-Back Hanging Bars

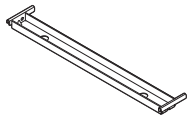

SFCK

Features

- Includes one short and one long bracket and attachment hardware.
- Refer to specification guide for additional required support.
- Attaches two base units together back-to-back or in-line.
- Black only.

Specification Tips

- Provides attached storage support for two or more Beside base units in back-to-back and/or in-line applications. Refer to Specification Guide for planning information.
- **Beside Base units 24"-42" (610mm-1067mm) must be appropriately attached for storage support. Refer to Specification Guide for planning information.**
- **All base units with drawers 24"-72" (610mm-1829mm) must be appropriately attached for storage support. Refer to Specification Guide for planning information.**
- See Specification Guide for planning requirements.

Number

QAGB-0000

Price

\$21.42

To Order, Specify:

- 1) Product number.
(No finish specification required.)

Depth

12" (305mm)

Number

SFCK-0013

Price

\$27.85

Features

- Includes one front-to-back hanging bar.
- Spans between side-to-side hanging bars in file drawers to convert drawer to front-to-back suspended filing format.
- Standard in black finish color only.

To Order, Specify:

- 1) Product number
(No finish specification required.)

Accessories

	Depth	Nominal Width	Actual Width	Number	Fabric Grade				
					A	B	C	D	E
Cushion	16.8"(427mm)	24"(610mm)	22.65"(575mm)	QBFC-1824-F	\$400.40	\$460.46	\$528.53	\$600.60	\$672.67
		30"(762mm)	28.65"(728mm)	QBFC-1830-F	462.80	532.22	610.91	694.20	777.49
		36"(914mm)	34.65"(880mm)	QBFC-1836-F	525.20	603.98	693.29	787.80	882.31
		42"(1067mm)	40.65"(1033mm)	QBFC-1842-F	587.60	675.74	775.67	881.40	987.13

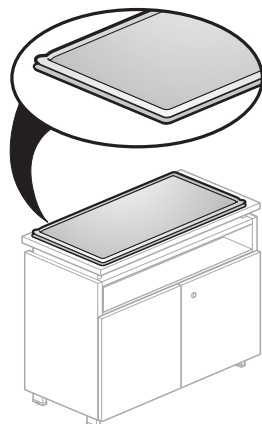

QBFC_F

Features

- Includes one cushion and non-slip material.
- .75"(19mm) thick cushion is cover stitched around perimeter edges.
- Cushion is inset 0.6000" from base unit perimeter edges.
- Cushion has a two-sided reversible surface; same fabric on both sides.

To Order, Specify:

- 1) Product number.
- 2) Fabric and color.

Specification Tips

- Cushion is not structural; to be used with a storage top.
- Cushion may be the same width or not as wide as the base unit.
- Patterned fabrics may not align on both sides of the cushion.

Counterweight

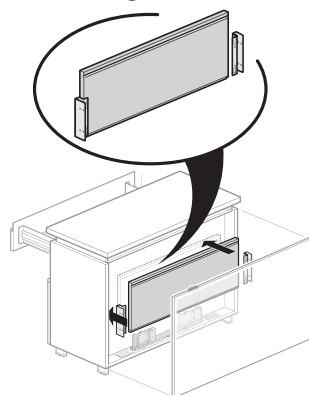

2670

Base Unit Width	Number	Price
24"(610mm) Single	2670-7001	\$410.27
30"(762mm) Single	2670-7002	420.98
36"(914mm) Single	2670-7003	431.69
42"(1067mm) Single	2670-7004	442.40
48"(1219mm) Double	2670-7005	133.89
60"(1524mm) Double	2670-7006	155.31
72"(1829mm) Double	2670-7007	176.73
48"(1219mm) Triple	2670-7008	133.89
60"(1524mm) Triple	2670-7009	155.31
72"(1829mm) Triple	2670-7010	176.73

Features

- Includes counterweight and attachment hardware.
- Installs in back of base unit and allows for standard electrical applications.
- Field installed.
- Counterweights must be the same width and case type (single, double, triple) as base unit.

To Order, Specify:

- 1) Product number.
(No finish specification required.)

Specification Tip

- For use with free-standing Beside base units with drawers and all units less than 48"(1219mm) wide. See Specification Guide for details.

Electrical Components

Infeed Harness

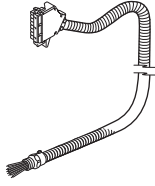

EUEH-0087-3
EUEH-0087-2
EUEH-0087-4



Description	Feed Length	Number	Price
3-Circuit			
	87"(2210mm)	EUEH-0087-3	\$173.83
	180"(4572mm)	EUEH-00F0-3	268.65
	300"(7620mm)	EUEH-00W0-3	452.66
4-Circuit, 2+2			
	87"(2210mm)	EUEH-0087-2	\$190.76
	180"(4572mm)	EUEH-00F0-2	285.58
	300"(7620mm)	EUEH-00W0-2	469.59
4-Circuit, 3+1			
	87"(2210mm)	EUEH-0087-4	\$190.76
	180"(4572mm)	EUEH-00F0-4	285.58
	300"(7620mm)	EUEH-00W0-4	469.59

Features

- Includes electrical harness in galvanized metal conduit.
- Conduit for 3-Circuit includes eight 12-gauge wires for up to three 20 amp circuits of power.
- Conduit for 4-Circuit includes six 12-gauge and two 10-gauge wires for up to four 20 amp circuits of power.
- Can be used to route power from floor to power distribution assembly.
- Can be used with a powered top feed pole to bring an additional set of three circuits into the powered component.
- Local electrician to provide secondary junction box at top of top feed pole.
- For use with components equipped with power components.
- Attaches at any receptacle site in powered component.
- **Designed for use with Reside Desking and Beside Storage.**

To Order, Specify:

- 1) Product number.
(No finish specification required.)

Specification Tips

- **Not for use with power sources other than 120 volt 60 hertz.**
- When used with Reside desking, a vertical base feed cover is a separately specified option.
- Attaches at any receptacle site or right-hand jumper location.
- Split tubing may be field supplied separately to cover exposed galvanized metal conduit.
- Do not mix 3-circuit with 4-circuit components. Do not mix 2+2 and 3+1 components.
- Components have unique polarity key and color coding (3-circuit = black; 2+2 = blue; 3+1 = green).

Electrical Components

Internal Power Base™ AI Base Feed

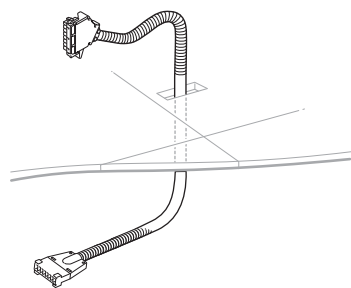

EUEJ-0064-3WF
EUEJ-0064-2WF
EUEJ-0064-4WF



Description	Feed Length	Number	Price
3-Circuit			
	64"(1626mm)	EUEJ-0064-3WF	\$173.83
	144"(3658mm)	EUEJ-0144-3WF	241.56
	300"(7620mm)	EUEJ-0300-3WF	576.84
4-Circuit, 2+2			
	64"(1626mm)	EUEJ-0064-2WF	\$190.76
	144"(3658mm)	EUEJ-0144-2WF	258.49
	300"(7620mm)	EUEJ-0300-2WF	593.77
4-Circuit, 3+1			
	64"(1626mm)	EUEJ-0064-4WF	\$190.76
	144"(3658mm)	EUEJ-0144-4WF	258.49
	300"(7620mm)	EUEJ-0300-4WF	593.77

Features

- Includes connector assembly which consists of one Power Base connector head, galvanized 1/2"(13mm) flexible metal conduit.
- Conduit for 3-Circuit includes eight 12-gauge wires for up to three 20 amp circuits of power.
- Conduit for 4-Circuit includes six 12-gauge and two 10-gauge wires for up to four 20 amp circuits of power.
- For use with components equipped with power components.
- Attaches at any receptacle site or right-hand jumper location and to a Power Base AI underfloor power system.
- **Designed for use with Reside Desking and Beside Storage.**

To Order, Specify:

- 1) Product number.
(No finish specification required.)

Specification Tips

- **Not for use with power sources other than 120 volt 60 hertz.**
- When used with Reside desking, a base feed cover is a separately specified option.
- Exposed split tubing may be field supplied separately to cover exposed galvanized metal conduit.
- Do not mix 3-circuit with 4-circuit components. Do not mix 2+2 and 3+1 components.
- Components have unique polarity key and color coding (3-circuit = black; 2+2 = blue; 3+1 = green).

Electrical Components

Base Feed Module — Architectural Concealed — Hardwire Connection

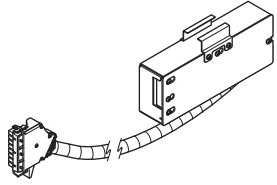

EUEB-0000-3HY
EUEB-0000-2HY
EUEB-0000-4HY



Description	Number	Price
3-Circuit	EUEB-0000-3HY	\$284.03
4-Circuit, 2+2	EUEB-0000-2HY	\$284.03
4-Circuit, 3+1	EUEB-0000-4HY	\$284.03

Features

- Includes one junction box with modular connector and three 1/2" (13mm) knockouts, flexible steel conduit.
- Conduit for 3-Circuit includes eight 12-gauge wires for up to three 20 amp circuits of power.
- Conduit for 4-Circuit includes six 12-gauge and two 10-gauge wires for up to four 20 amp circuits of power.
- For use with components equipped with power components.
- For floor, column or wall hardwire connections.
- Conforms to New York City electrical code.
- **Designed for use with Reside Desking and Beside Storage.**

To Order, Specify:

- 1) Product number.
(No finish specification required.)

Specification Tips

- **Not for use with power sources other than 120 volt 60 hertz.**
- For installation on components 42" (1067mm) or larger.
- Connector plugs into receptacle site on left side of desking and right side of storage.
- Connector may plug into jumper site on right side of Reside desking.
- Conduit and fittings for connection between building and junction box are supplied by local electricians.
- Do not mix 3-circuit with 4-circuit components. Do not mix 2+2 and 3+1 components.
- Components have unique polarity key and color coding (3-circuit = black; 2+2 = blue; 3+1 = green).

Electrical Components

Description	Ceiling Height	Pole Length	Number	Trim	
				A	B
Top Feed — Beside Storage Only					
Floor Mount Height					
3-Circuit	10'(3048mm)	138"(3505mm)	EQET-C000-3	\$822.54	\$877.08
	12'(3658mm)	150"(3810mm)	EQET-E400-3	840.72	904.35
4-Circuit, 2+2	10'(3048mm)	138"(3505mm)	EQET-C000-2	\$822.54	\$877.08
	12'(3658mm)	150"(3810mm)	EQET-E400-2	840.72	904.35
4-Circuit, 3+1	10'(3048mm)	138"(3505mm)	EQET-C000-4	\$822.54	\$877.08
	12'(3658mm)	150"(3810mm)	EQET-E400-4	840.72	904.35

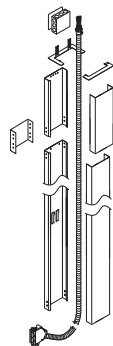

EQET-C000-3
EQET-C000-2
EQET-C000-4



Features

- Includes one 180"(4572mm) electrical harness in metal conduit, electrical box, ceiling bezel plate, pole and hardware.
- Conduit for 3-Circuit includes eight 12-gauge wires for up to three 20 amp circuits of power.
- Conduit for 4-Circuit includes six 12-gauge and two 10-gauge wires for up to four 20 amp circuits of power.
- For connection to the electrical source located in space above a drop ceiling.
- Removable cover on poles provides access to pathway.
- Top feed pole dimensions: 2.5"(64mm) x 8"(203mm).
- Harness attaches to flex connector or receptacle site location.
- **Designed for use with Beside Storage only.**

To Order, Specify:

- 1) Product number.
- 2) Trim color.

Specification Tips

- **Not for use with power sources other than 120 volt 60 hertz.**
- Beside Storage top feed may interfere with Tool Rail or Screen applications.
- Beside Storage floor mount Top Feed mounts to floor, attaches to Beside Storage at any side and ceiling.
- Floor attachment hardware is field supplied.
- If Beside Storage is back-to-back, a minimum gap of 2.5"(63.5mm) must be provided or if no gap, separately specify Top Feed Grommet – field cutting required.
- Do not mix 3-circuit with 4-circuit components. Do not mix 2+2 and 3+1 components.
- Components have unique polarity key and color coding (3-circuit = black; 2+2 = blue; 3+1 = green).

Top Feed Grommet — Beside Storage Only

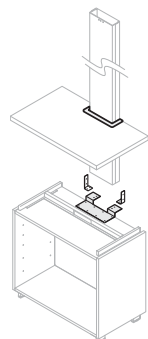

EQAG-0000-PT

Description	Number	Trim	
		A	B
	EQAG-0000-PT	\$45.44	\$51.13

Features

- Includes grommet and attachment hardware.
- For use when mounting Beside Top Feed through storage top.
- **Designed for use with Beside Storage only.**

To Order, Specify:

- 1) Product number.
- 2) Trim color.

Specification Tips

- Beside storage must be attached to another Beside Storage, Beside desk, panel or a wall.
- Grommet requires field modification of storage top.
- Refer to Specification Guide for planning applications.

Electrical Components

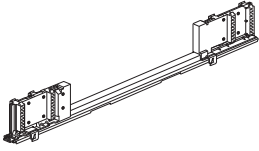
	Description	Panel Width	Number	Price
Power Distribution Assembly — Beside Storage Only  EUEP-0030-3Q EUEP-0030-2Q EUEP-0030-4Q	Hardwire and 3-Circuit			
		30"(762mm)	EUEP-0030-3Q	\$40.79
		36"(914mm)	EUEP-0036-3Q	46.49
		42"(1067mm)	EUEP-0042-3Q	52.19
		48"(1219mm)	EUEP-0048-3Q	58.84
		54"(1372mm)	EUEP-0054-3Q	63.59
		60"(1524mm)	EUEP-0060-3Q	69.29
		66"(1676mm)	EUEP-0066-3Q	75.94
		72"(1829mm)	EUEP-0072-3Q	80.69
		4-Circuit, 2+2		
	30"(762mm)	EUEP-0030-2Q	\$45.34	
	36"(914mm)	EUEP-0036-2Q	51.04	
	42"(1067mm)	EUEP-0042-2Q	56.74	
	48"(1219mm)	EUEP-0048-2Q	63.39	
	54"(1372mm)	EUEP-0054-2Q	68.14	
	60"(1524mm)	EUEP-0060-2Q	73.84	
	66"(1676mm)	EUEP-0066-2Q	80.49	
	72"(1829mm)	EUEP-0072-2Q	85.24	
	4-Circuit, 3+1			
	30"(762mm)	EUEP-0030-4Q	\$45.34	
	36"(914mm)	EUEP-0036-4Q	51.04	
	42"(1067mm)	EUEP-0042-4Q	56.74	
	48"(1219mm)	EUEP-0048-4Q	63.39	
	54"(1372mm)	EUEP-0054-4Q	68.14	
	60"(1524mm)	EUEP-0060-4Q	73.84	
	66"(1676mm)	EUEP-0066-4Q	80.49	
	72"(1829mm)	EUEP-0072-4Q	85.24	



Features

- Includes one power distribution assembly (PDA) and attachment hardware to attach power to Beside Storage.
- Attached to Beside Storage power and communication recessed compartment.
- Field installed.

Specification Tips:

- **For use to access power or route power through Beside Storage.**
- To access power in Beside Storage, separately specify 3-circuit or 4-circuit conduit, Power Tap and bracket.
- **Specify jumper separately.**
- **Beside Storage PDA's do not accept receptacles.**
- Do not mix 3-circuit with 4-circuit components. Do not mix 2+2 and 3+1 components.
- Components have unique polarity key and color coding (3-circuit = black; 2+2 = blue; 3+1 = green).

To Order, Specify:

- 1) Product number.
(No finish specification required.)

Electrical Components

Jumpers

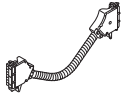

EUEJ-0018-3
EUEJ-0018-2
EUEJ-0018-4



Description	Actual Length	Number	Price
3-Circuit			
	18"(457mm)	EUEJ-0018-3	\$ 97.71
	20"(508mm)	EUEJ-0020-3	99.98
	24"(610mm)	EUEJ-0024-3	104.52
	30"(762mm)	EUEJ-0030-3	111.33
	36"(914mm)	EUEJ-0036-3	118.14
	42"(1067mm)	EUEJ-0042-3	124.95
	48"(1219mm)	EUEJ-0048-3	131.76
	54"(1372mm)	EUEJ-0054-3	138.57
	60"(1524mm)	EUEJ-0060-3	145.38
	76"(1930mm)	EUEJ-0076-3	163.54
	96"(2438mm)	EUEJ-0096-3	186.24
	144"(3658mm)	EUEJ-00E4-3	240.72
	192"(4877mm)	EUEJ-00K2-3	295.20
4-Circuit, 2+2			
	18"(457mm)	EUEJ-0018-2	\$104.53
	20"(508mm)	EUEJ-0020-2	106.80
	24"(610mm)	EUEJ-0024-2	111.34
	30"(762mm)	EUEJ-0030-2	118.15
	36"(914mm)	EUEJ-0036-2	124.96
	42"(1067mm)	EUEJ-0042-2	131.77
	48"(1219mm)	EUEJ-0048-2	138.58
	54"(1372mm)	EUEJ-0054-2	145.39
	60"(1524mm)	EUEJ-0060-2	152.20
	76"(1930mm)	EUEJ-0076-2	170.36
	96"(2438mm)	EUEJ-0096-2	193.06
	144"(3658mm)	EUEJ-00E4-2	247.54
	192"(4877mm)	EUEJ-00K2-2	302.02
4-Circuit, 3+1			
	18"(457mm)	EUEJ-0018-4	\$104.53
	20"(508mm)	EUEJ-0020-4	106.80
	24"(610mm)	EUEJ-0024-4	111.34
	30"(762mm)	EUEJ-0030-4	118.15
	36"(914mm)	EUEJ-0036-4	124.96
	42"(1067mm)	EUEJ-0042-4	131.77
	48"(1219mm)	EUEJ-0048-4	138.58
	54"(1372mm)	EUEJ-0054-4	145.39
	60"(1524mm)	EUEJ-0060-4	152.20
	76"(1930mm)	EUEJ-0076-4	170.36
	96"(2438mm)	EUEJ-0096-4	193.06
	144"(3658mm)	EUEJ-00E4-4	247.54
	192"(4877mm)	EUEJ-00K2-4	302.02

Features

- Includes flexible metal power jumper with safety latches.
- Jumpers cannot be coupled together.
- Field installed.
- **Designed for use with Reside Desking and Beside Storage.**

Specification Tips:

- **Jumpers are used to connect between Power Distribution Assemblies mounted in Utility Trays and/or between Reside desking and Beside storage powered units (desk to desk/ storage to storage/desk to storage/storage to desk).**
- Beside Storage in-line applications; specify 42"(1067mm) jumper.
- Beside Storage dual sided, single row application; specify 54"(1372mm) jumper.
- Refer to Specification Guide for calculation of jumper length.
- Do not mix 3-circuit with 4-circuit components. Do not mix 2+2 and 3+1 components.
- Components have unique polarity key and color coding (3-circuit = black; 2+2 = blue; 3+1 = green).

To Order, Specify:

- 1) Product number.
(No finish specification required.)

Electrical Components

Hardwire

	Floor Mount	Ceiling Height	Pole Length	Number	Trim A	B
Top Feed — Hardwire Beside Storage Only	Hardwire	10'(3048mm)	138"(3505mm)	EQET-C000-C	\$289.70	\$344.24
		12'(3658mm)	150"(3810mm)	EQET-E400-C	307.88	371.51

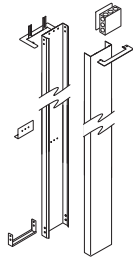

Features

- Includes one electrical box, ceiling bezel plate, pole and hardware.
- For connection to the electrical source located in space above a drop ceiling.
- For routing and cabling capacities, refer to Specification Guide.
- Removable cover on poles provides access to pathway.
- Top feed pole dimensions: 2.5"(64mm) x 8"(203mm).
- **Designed for use with Beside Storage only.**

To Order, Specify:

- 1) Product number.
- 2) Trim color.

Specification Tips

- **Not for use with power sources other than 120 volt 60 hertz.**
- Beside Storage Top Feed may interfere with Tool Rail or Screen applications.
- Beside Storage floor mount Top Feed mounts to floor, attaches to Beside Storage at any side and ceiling.
- Floor attachment hardware is field installed.
- Do not mix 3-circuit with 4-circuit components. Do not mix 2+2 and 3+1 components.
- Components have unique polarity key and color coding (3-circuit = black; 2+2 = blue; 3+1 = green).

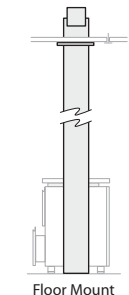

Floor Mount
EQET-C000-C

Top Feed Grommet — Beside Storage Only

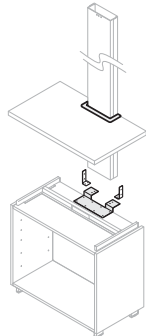

EQAG-0000-PT

Features

- Includes grommet and attachment hardware.
- For use when mounting Beside Top Feed through storage top.
- **Designed for use with Beside Storage only.**

Specification Tips

- Beside storage must be attached to additional Beside Storage, Reside desking, panel or a wall.
- Grommet requires field modification of storage top.
- Refer to Specification Guide for planning applications.

	Number	Trim A	B
	EQAG-0000-PT	\$45.44	\$51.13

To Order, Specify:

- 1) Product number.
- 2) Trim color.

Hardwire Kit — Beside Storage Only

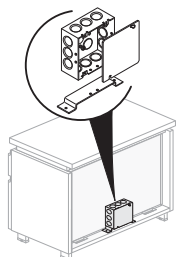

EQEP-0000-C

Features

- Includes one electrical box with nine 1/2"(13mm) knockouts, blank cover plate and mounting hardware.
- Attaches to Beside Storage recessed compartment sidewall.
- Field installed.
- **Designed for use with Beside Storage only.**

Specification Tips

- For use with Hardwire Power Taps for electrical connection.
- **Not intended for mounting of receptacles.**
- **Wiring, fittings and conduit are field supplied.**

EQEP-0000-C	\$124.97
-------------	-----------------

To Order, Specify:

- 1) Product number.
- 2) Trim color.

Electrical Components

Hardwire

**Patch Cord
Data Holder Bracket —
Beside Storage Only**

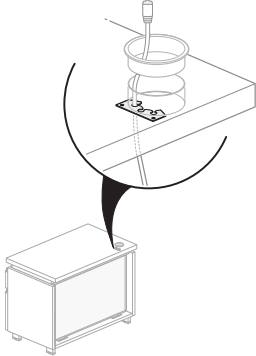

EQAD-0000-GD

Features

- Includes bracket and attachment hardware.
- Designed for use with grommet and sidewall mounting bracket for holding up to three patch cords.
- Designed for use with patch cords having a diameter of 0.16”(4mm) to 0.20”(5mm).

Specification Tips

- Mounts to underside of Beside Storage Top.
- Sidewall bracket for holding up to three patch cords.
- Field supplied.
- Refer to Specification Guide for planning applications.

Number	Trim	
	A	B
EUAD-0000-GD	\$20.45	\$26.14

To Order, Specify:

- 1) Product number.
- 2) Trim color.

**Modular Furniture
Telecommunication
Opening —
Beside Storage Only**

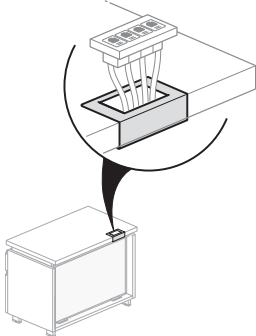

EUDZ-0000-WDD

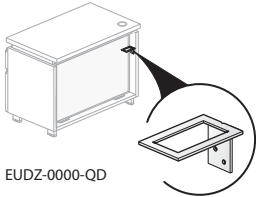

EUDZ-0000-QD

Description

- Storage — Top Mount
- Storage — Sidewall Mount

Number	Trim	
	A	B
EUDZ-0000-WD	\$34.09	\$39.78
EUDZ-0000-QD	34.09	39.78

Features

- Includes bracket and attachment hardware.
- Provides a 1.38”(35mm) x 2.71”(69mm) opening for field supplied modular furniture telecommunication faceplate.
- Storage sidewall bracket mounts Beside Storage recessed compartment sidewall.
- Storage top bracket mounts to back edge of Beside Storage Top.

Specification Tips

- Sidewall storage bracket may interfere with base feed module.
- Coordination of data and power with installation of double sided Beside Storage is recommended.
- Sidewall bracket data patch cords should be available during installation.
- Top mount Modular Furniture Telecommunication requires field modification.
- Field supplied face plate and patch cord.
- Refer to Specification Guide for planning applications.

To Order, Specify:

- 1) Product number.
- 2) Trim color.

Stanchion Kit — G

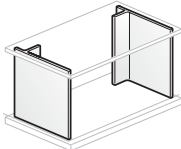
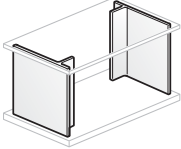
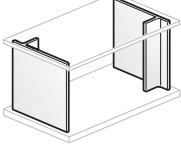
	Actual Height	Nominal Height	Width	Number	Trim A	B
	9.91"(252mm)	10"(254mm)	24"(610mm)	QUSS-1024-GEN	\$342.78	\$348.94
			30"(762mm)	QUSS-1030-GEN	342.78	348.94
			36"(914mm)	QUSS-1036-GEN	342.78	348.94
			42"(1067mm)	QUSS-1042-GEN	342.78	348.94
	11.25"(286mm)	11"(279mm)	24"(610mm)	QUSS-1124-GMN	\$355.64	\$362.64
			30"(762mm)	QUSS-1130-GMN	355.64	362.64
			36"(914mm)	QUSS-1136-GMN	355.64	362.64
			42"(1067mm)	QUSS-1142-GMN	355.64	362.64
	11.91"(303mm)	12"(305mm)	24"(610mm)	QUSS-1224-GNN	\$368.50	\$375.90
			30"(762mm)	QUSS-1230-GNN	368.50	375.90
			36"(914mm)	QUSS-1236-GNN	368.50	375.90
			42"(1067mm)	QUSS-1242-GNN	368.50	375.90
	14.5"(368mm)	15"(381mm)	24"(610mm)	QUSS-1524-GUN	\$407.08	\$416.10
			30"(762mm)	QUSS-1530-GUN	407.08	416.10
			36"(914mm)	QUSS-1536-GUN	407.08	416.10
			42"(1067mm)	QUSS-1542-GUN	407.08	416.10
	15.91"(404mm)	16"(406mm)	24"(610mm)	QUSS-1624-GPN	\$419.94	\$429.84
			30"(762mm)	QUSS-1630-GPN	419.94	429.84
			36"(914mm)	QUSS-1636-GPN	419.94	429.84
			42"(1067mm)	QUSS-1642-GPN	419.94	429.84
	17.91"(455mm)	18"(457mm)	24"(610mm)	QUSS-1824-GFN	\$445.66	\$456.80
			30"(762mm)	QUSS-1830-GFN	445.66	456.80
			36"(914mm)	QUSS-1836-GFN	445.66	456.80
			42"(1067mm)	QUSS-1842-GFN	445.66	456.80

QUSS

Features

- Includes stanchions and attachment hardware.
- For use with a single base unit or multiple units of matching widths in a side-by-side application.
- Field assembled and installed.

Specification Tips

- User side is the inset side.
- Stanchion kits with separately specified shelves create a hutch which is designed to be used with a Beside base unit.
- A single stanchion kit can be used to support a Beside overhead storage unit. The combination of the Beside base unit, Stanchion kit and Overhead Storage or hutch shelf not to exceed 58"(1473mm).
- Binder Storage minimum height 15"(381mm).
- Refer to accessory price pages for stanchion height minimum requirement.
- Stanchion kits G and M not available at widths greater than 42"(1067mm).
- Shelf must match width of stanchion kit.
- Stanchion kits can be configured into multiple configurations.
- Refer to Specification Guide for planning information and actual dimensions.

To Order, Specify:

- 1) Product number.
- 2) Painted color Stanchion left.
- 3) Painted color Stanchion right.

Note: Upcharge for mixed grade fabric or trim surfaces, refer to the electronic design and specification tools for pricing.

Stanchion Kit — H

	Actual Height	Nominal Height	Width	Number	Trim A	B
Stanchion Kit — H	9.91"(252mm)	10"(254mm)	48"(1219mm)	QUSS-1048-HEN	\$396.34	\$405.58
			54"(1372mm)	QUSS-1054-HEN	396.34	405.58
			60"(1524mm)	QUSS-1060-HEN	396.34	405.58
			66"(1676mm)	QUSS-1066-HEN	396.34	405.58
			72"(1829mm)	QUSS-1072-HEN	396.34	405.58
	11.25"(286mm)	11"(279mm)	48"(1219mm)	QUSS-1148-HMN	\$412.41	\$422.91
			54"(1372mm)	QUSS-1154-HMN	412.41	422.91
			60"(1524mm)	QUSS-1160-HMN	412.41	422.91
			66"(1676mm)	QUSS-1166-HMN	412.41	422.91
			72"(1829mm)	QUSS-1172-HMN	412.41	422.91
	11.91"(303mm)	12"(305mm)	48"(1219mm)	QUSS-1248-HNN	\$428.48	\$439.58
			54"(1372mm)	QUSS-1254-HNN	428.48	439.58
			60"(1524mm)	QUSS-1260-HNN	428.48	439.58
			66"(1676mm)	QUSS-1266-HNN	428.48	439.58
			72"(1829mm)	QUSS-1272-HNN	428.48	439.58
14.5"(368mm)	15"(381mm)	48"(1219mm)	QUSS-1548-HUN	\$476.69	\$490.22	
		54"(1372mm)	QUSS-1554-HUN	476.69	490.22	
		60"(1524mm)	QUSS-1560-HUN	476.69	490.22	
		66"(1676mm)	QUSS-1566-HUN	476.69	490.22	
		72"(1829mm)	QUSS-1572-HUN	476.69	490.22	
15.9"(404mm)	16"(406mm)	48"(1219mm)	QUSS-1648-HPN	\$492.76	\$507.61	
		54"(1372mm)	QUSS-1654-HPN	492.76	507.61	
		60"(1524mm)	QUSS-1660-HPN	492.76	507.61	
		66"(1676mm)	QUSS-1666-HPN	492.76	507.61	
		72"(1829mm)	QUSS-1672-HPN	492.76	507.61	
17.91"(455mm)	18"(457mm)	48"(1219mm)	QUSS-1848-HFN	\$524.90	\$541.61	
		54"(1372mm)	QUSS-1854-HFN	524.90	541.61	
		60"(1524mm)	QUSS-1860-HFN	524.90	541.61	
		66"(1676mm)	QUSS-1866-HFN	524.90	541.61	
		72"(1829mm)	QUSS-1872-HFN	524.90	541.61	

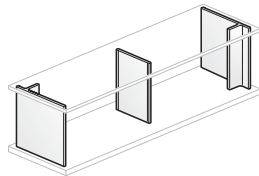
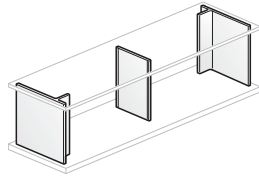
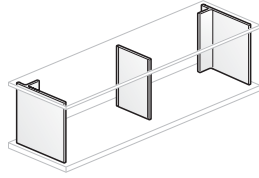

QUSS

Features

- Includes thick stanchions and attachment hardware.
- For use with a single base unit or multiple units of matching widths in a side-by-side application.
- Field assembled and installed.

Specification Tips

- User side is the inset side.
- Stanchion kits with separately specified shelves create a hutch which is designed to be used with a Beside base unit.
- A single stanchion kit can be used to support a Beside overhead storage unit. The combination of the Beside base unit, Stanchion kit and Overhead Storage or hutch shelf not to exceed 58"(1473mm).
- Binder Storage minimum height 15"(381mm).
- Refer to accessory price pages for stanchion height minimum requirement.
- Stanchion kits G and M not available in widths greater than 42"(1067mm).
- Shelf must match width of stanchion kit.
- Stanchion kits can be configured into multiple configurations.
- Refer to Specification Guide for planning information and actual dimensions.

To Order, Specify:

- 1) Product number.
- 2) Painted color Stanchion left.
- 3) Painted color Stanchion right.
- 4) Painted color Center Divider (for widths 48"(1219mm) and higher).

Note: Upcharge for mixed grade fabric or trim surfaces, refer to the electronic design and specification tools for pricing.

This page intentionally blank

Stanchion Kit — M

Stanchion Kit — M

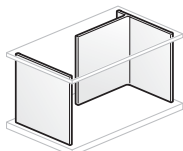
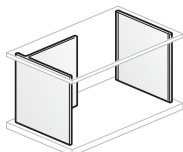

QUSS

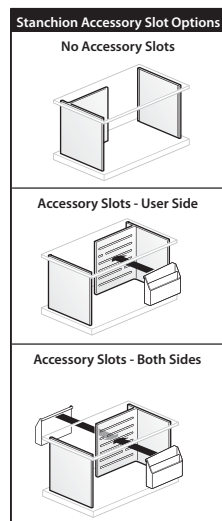

Features

- Includes stanchions and attachment hardware.
- For use with a single base unit or multiple base units of matching widths in a side-by-side application.
- Accessory Functionality:
 - A** User sided accessory slot for right hand stanchion.
 - B** User sided accessory slot for left hand stanchion.
 - D** Both side accessory slot for right hand stanchion.
 - E** Both side accessory slot for left hand stanchion.
 - L** No accessory left.
 - R** No accessory right.
- Field assembled and installed.

Specification Tips

- User side is the inset side.
- Stanchion kits with separately specified shelves create a hutch which is designed to be used with a Beside base unit.
- A single stanchion kit can be used to support a Beside overhead storage unit. The combination of the Beside base unit, Stanchion kit and Overhead Storage or hutch shelf not to exceed 58”(1473mm).
- Binder Storage minimum height 15”(381mm).
- Refer to accessory price pages for stanchion height minimum requirement.
- Stanchion kits G and M not available in widths greater than 42”(1067mm).
- Shelf must match width of the stanchion kit.
- Stanchion kits can be configured into multiple configurations.
- Refer to Specification Guide for planning information and actual dimensions.

To Order, Specify:

1) Product number, including:

① Accessory Slots Options:

User Side

A Right-Hand Stanchion**B** Left-Hand Stanchion

Both Sides

D Right-Hand Stanchion**E** Left-Hand Stanchion

No Accessory Slot

R Right-Hand Stanchion**L** Left-Hand Stanchion

2) Painted color Stanchion Left.

3) Painted color Stanchion Right.

Note: Upcharge for mixed grade fabric or trim surfaces, refer to the electronic design and specification tools for pricing.

Stanchion Kit — M

Actual Height	Nominal Height	Width	Number ①	Trim A	B
Accessory Slots — User Side (A or B)					
9.91"(252mm)	10"(254mm)	24"(610mm)	QUSS-1024-ME ■	\$371.71	\$384.04
		30"(762mm)	QUSS-1030-ME ■	378.13	392.00
		36"(914mm)	QUSS-1036-ME ■	384.55	399.96
		42"(1067mm)	QUSS-1042-ME ■	390.97	407.92
11.25"(286mm)	11"(279mm)	24"(610mm)	QUSS-1124-MM ■	\$383.49	\$397.49
		30"(762mm)	QUSS-1130-MM ■	389.91	405.66
		36"(914mm)	QUSS-1136-MM ■	396.33	413.83
		42"(1067mm)	QUSS-1142-MM ■	402.75	422.00
11.91"(303mm)	12"(305mm)	24"(610mm)	QUSS-1224-MN ■	\$395.27	\$410.08
		30"(762mm)	QUSS-1230-MN ■	401.69	418.36
		36"(914mm)	QUSS-1236-MN ■	408.11	426.63
		42"(1067mm)	QUSS-1242-MN ■	414.53	434.90
14.5"(368mm)	15"(381mm)	24"(610mm)	QUSS-1524-MU ■	\$430.61	\$448.65
		30"(762mm)	QUSS-1530-MU ■	437.03	457.33
		36"(914mm)	QUSS-1536-MU ■	443.45	466.00
		42"(1067mm)	QUSS-1542-MU ■	449.87	474.68
15.91"(404mm)	16"(406mm)	24"(610mm)	QUSS-1624-MP ■	\$442.39	\$462.19
		30"(762mm)	QUSS-1630-MP ■	448.81	471.08
		36"(914mm)	QUSS-1636-MP ■	455.23	479.98
		42"(1067mm)	QUSS-1642-MP ■	461.65	488.87
17.91"(455mm)	18"(457mm)	24"(610mm)	QUSS-1824-MF ■	\$465.95	\$488.23
		30"(762mm)	QUSS-1830-MF ■	472.37	497.44
		36"(914mm)	QUSS-1836-MF ■	478.79	506.64
		42"(1067mm)	QUSS-1842-MF ■	485.21	515.85
Accessory Slot — Both Sides (D or E)					
9.91"(252mm)	10"(254mm)	24"(610mm)	QUSS-1024-ME ■	\$400.63	\$412.96
		30"(762mm)	QUSS-1030-ME ■	410.26	424.13
		36"(914mm)	QUSS-1036-ME ■	419.89	435.30
		42"(1067mm)	QUSS-1042-ME ■	429.52	446.47
11.25"(286mm)	11"(279mm)	24"(610mm)	QUSS-1124-MM ■	\$415.62	\$429.62
		30"(762mm)	QUSS-1130-MM ■	425.25	441.00
		36"(914mm)	QUSS-1136-MM ■	434.88	452.38
		42"(1067mm)	QUSS-1142-MM ■	444.51	463.76
11.91"(303mm)	12"(305mm)	24"(610mm)	QUSS-1224-MN ■	\$430.61	\$445.42
		30"(762mm)	QUSS-1230-MN ■	440.24	456.91
		36"(914mm)	QUSS-1236-MN ■	449.87	468.39
		42"(1067mm)	QUSS-1242-MN ■	459.50	479.87
14.5"(368mm)	15"(381mm)	24"(610mm)	QUSS-1524-MU ■	\$475.58	\$493.62
		30"(762mm)	QUSS-1530-MU ■	485.21	505.51
		36"(914mm)	QUSS-1536-MU ■	494.84	517.39
		42"(1067mm)	QUSS-1542-MU ■	504.47	529.28
15.91"(404mm)	16"(406mm)	24"(610mm)	QUSS-1624-MP ■	\$490.57	\$510.37
		30"(762mm)	QUSS-1630-MP ■	500.20	522.47
		36"(914mm)	QUSS-1636-MP ■	509.83	534.58
		42"(1067mm)	QUSS-1642-MP ■	519.46	546.68
17.91"(455mm)	18"(457mm)	24"(610mm)	QUSS-1824-MF ■	\$520.55	\$542.83
		30"(762mm)	QUSS-1830-MF ■	530.18	555.25
		36"(914mm)	QUSS-1836-MF ■	539.81	567.66
		42"(1067mm)	QUSS-1842-MF ■	549.44	580.08

Stanchion Kit — M

	Actual Height	Nominal Height	Width	Number ①	Trim A	B
No Accessory Slot (L or R)						
	9.91"(252mm)	10"(254mm)	24"(610mm)	QUSS-1024-ME ■	\$342.79	\$355.12
			30"(762mm)	QUSS-1030-ME ■	346.00	359.87
			36"(914mm)	QUSS-1036-ME ■	349.21	364.62
			42"(1067mm)	QUSS-1042-ME ■	352.42	369.37
	11.25"(286mm)	11"(279mm)	24"(610mm)	QUSS-1124-MM ■	\$351.36	\$365.36
			30"(762mm)	QUSS-1130-MM ■	354.57	370.32
			36"(914mm)	QUSS-1136-MM ■	357.78	375.28
			42"(1067mm)	QUSS-1142-MM ■	360.99	380.24
	11.91"(303mm)	12"(305mm)	24"(610mm)	QUSS-1224-MN ■	\$359.93	\$374.74
			30"(762mm)	QUSS-1230-MN ■	363.14	379.81
			36"(914mm)	QUSS-1236-MN ■	366.35	384.87
			42"(1067mm)	QUSS-1242-MN ■	369.56	389.93
	14.5"(368mm)	15"(381mm)	24"(610mm)	QUSS-1524-MU ■	\$385.64	\$403.68
			30"(762mm)	QUSS-1530-MU ■	388.85	409.15
			36"(914mm)	QUSS-1536-MU ■	392.06	414.61
			42"(1067mm)	QUSS-1542-MU ■	395.27	420.08
	15.91"(404mm)	16"(406mm)	24"(610mm)	QUSS-1624-MP ■	\$394.21	\$414.01
			30"(762mm)	QUSS-1630-MP ■	397.42	419.69
			36"(914mm)	QUSS-1636-MP ■	400.63	425.38
			42"(1067mm)	QUSS-1642-MP ■	403.84	431.06
	17.91"(455mm)	18"(457mm)	24"(610mm)	QUSS-1824-MF ■	\$411.35	\$433.63
			30"(762mm)	QUSS-1830-MF ■	414.56	439.63
			36"(914mm)	QUSS-1836-MF ■	417.77	445.62
			42"(1067mm)	QUSS-1842-MF ■	420.98	451.62

This page intentionally blank

Stanchion Kit — N

Stanchion Kit — N

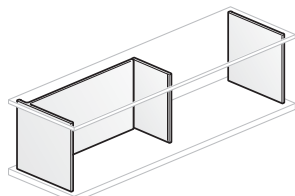
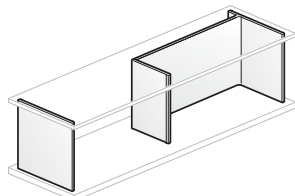

QUSS

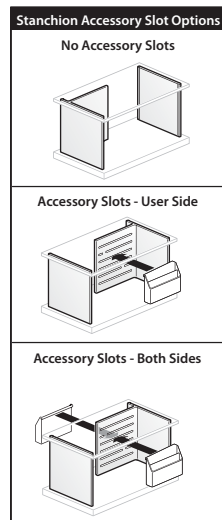

Features

- Includes stanchions and attachment hardware.
- For use with a single base unit or multiple base units of matching widths in a side-by-side application.
- Accessory Functionality:
 - A** User sided accessory slot for right hand stanchion.
 - B** User sided accessory slot for left hand stanchion.
 - D** Both side accessory slot for right hand stanchion.
 - E** Both side accessory slot for left hand stanchion.
 - L** No accessory left.
 - R** No accessory right.
- Field assembled and installed.

Specification Tips

- User side is the inset side.
- Stanchion kits with separately specified shelves create a hutch which is designed to be used with a Beside base unit.
- A single stanchion kit can be used to support a Beside overhead storage unit. The combination of the Beside base unit, Stanchion kit and Overhead Storage or hutch shelf not to exceed 58”(1473mm).
- Binder Storage minimum height 15”(381mm).
- Refer to accessory price pages for stanchion height minimum requirement.
- Stanchion kits not available in widths greater than 72”(1829mm).
- Shelf must match width of the stanchion kit.
- Stanchion kits can be configured into multiple configurations.
- Refer to Specification Guide for planning information and actual dimensions.

To Order, Specify:

1) Product number, including:

1 Accessory Slots Options:

User Side

A Right-Hand Stanchion

B Left-Hand Stanchion

Both Sides

D Right-Hand Stanchion

E Left-Hand Stanchion

No Accessory Slot

R Right-Hand Stanchion

L Left-Hand Stanchion

2) Painted color Stanchion Left.

3) Painted color Stanchion Right.

4) Painted color Center Divider (for widths 48”(1219mm) and higher).

Note: Upcharge for mixed grade fabric or trim surfaces, refer to the electronic design and specification tools for pricing.

Stanchion Kit — N

Actual Height	Nominal Height	Width	Number ①	Trim A	B
Accessory Slot — User Side (A or B)					
9.91"(252mm)	10"(254mm)	48"(1219mm)	QUSS-1048-NE	\$450.95	\$472.52
		54"(1372mm)	QUSS-1054-NE	457.37	480.48
		60"(1524mm)	QUSS-1060-NE	463.79	488.45
		66"(1676mm)	QUSS-1066-NE	470.21	496.41
		72"(1829mm)	QUSS-1072-NE	476.63	504.37
11.25"(286mm)	11"(279mm)	48"(1219mm)	QUSS-1148-NM	\$465.94	\$490.44
		54"(1372mm)	QUSS-1154-NM	472.36	498.61
		60"(1524mm)	QUSS-1160-NM	478.78	506.78
		66"(1676mm)	QUSS-1166-NM	485.20	514.95
		72"(1829mm)	QUSS-1172-NM	491.62	523.12
11.91"(303mm)	12"(305mm)	48"(1219mm)	QUSS-1248-NN	\$480.93	\$506.85
		54"(1372mm)	QUSS-1254-NN	487.35	515.13
		60"(1524mm)	QUSS-1260-NN	493.77	523.40
		66"(1676mm)	QUSS-1266-NN	500.19	531.67
		72"(1829mm)	QUSS-1272-NN	506.61	539.94
14.5"(368mm)	15"(381mm)	48"(1219mm)	QUSS-1548-NU	\$525.90	\$557.47
		54"(1372mm)	QUSS-1554-NU	532.32	566.15
		60"(1524mm)	QUSS-1560-NU	538.74	574.82
		66"(1676mm)	QUSS-1566-NU	545.16	583.50
		72"(1829mm)	QUSS-1572-NU	551.58	592.17
15.91"(404mm)	16"(406mm)	48"(1219mm)	QUSS-1648-NP	\$540.89	\$575.53
		54"(1372mm)	QUSS-1654-NP	547.31	584.43
		60"(1524mm)	QUSS-1660-NP	553.73	593.32
		66"(1676mm)	QUSS-1666-NP	560.15	602.22
		72"(1829mm)	QUSS-1672-NP	566.57	611.11
17.91"(455mm)	18"(457mm)	48"(1219mm)	QUSS-1848-NF	\$570.87	\$609.87
		54"(1372mm)	QUSS-1854-NF	577.29	619.07
		60"(1524mm)	QUSS-1860-NF	583.71	628.28
		66"(1676mm)	QUSS-1866-NF	590.13	637.48
		72"(1829mm)	QUSS-1872-NF	596.55	646.69
Accessory Slot — Both Sides (D or E)					
9.91"(252mm)	10"(254mm)	48"(1219mm)	QUSS-1048-NE	\$492.71	\$514.28
		54"(1372mm)	QUSS-1054-NE	502.34	525.45
		60"(1524mm)	QUSS-1060-NE	511.97	536.63
		66"(1676mm)	QUSS-1066-NE	521.60	547.80
		72"(1829mm)	QUSS-1072-NE	531.23	558.97
11.25"(286mm)	11"(279mm)	48"(1219mm)	QUSS-1148-NM	\$510.91	\$535.41
		54"(1372mm)	QUSS-1154-NM	520.54	546.79
		60"(1524mm)	QUSS-1160-NM	530.17	558.17
		66"(1676mm)	QUSS-1166-NM	539.80	569.55
		72"(1829mm)	QUSS-1172-NM	549.43	580.93
11.91"(303mm)	12"(305mm)	48"(1219mm)	QUSS-1248-NN	\$529.11	\$555.03
		54"(1372mm)	QUSS-1254-NN	538.74	566.52
		60"(1524mm)	QUSS-1260-NN	548.37	578.00
		66"(1676mm)	QUSS-1266-NN	558.00	589.48
		72"(1829mm)	QUSS-1272-NN	567.63	600.96
14.5"(368mm)	15"(381mm)	48"(1219mm)	QUSS-1548-NU	\$583.71	\$615.28
		54"(1372mm)	QUSS-1554-NU	593.34	627.17
		60"(1524mm)	QUSS-1560-NU	602.97	639.05
		66"(1676mm)	QUSS-1566-NU	612.60	650.94
		72"(1829mm)	QUSS-1572-NU	622.23	662.82
15.91"(404mm)	16"(406mm)	48"(1219mm)	QUSS-1648-NP	\$601.91	\$636.55
		54"(1372mm)	QUSS-1654-NP	611.54	648.66
		60"(1524mm)	QUSS-1660-NP	621.17	660.76
		66"(1676mm)	QUSS-1666-NP	630.80	672.87
		72"(1829mm)	QUSS-1672-NP	640.43	684.97
17.91"(455mm)	18"(457mm)	48"(1219mm)	QUSS-1848-NF	\$638.31	\$677.31
		54"(1372mm)	QUSS-1854-NF	647.94	689.72
		60"(1524mm)	QUSS-1860-NF	657.57	702.14
		66"(1676mm)	QUSS-1866-NF	667.20	714.55
		72"(1829mm)	QUSS-1872-NF	676.83	726.97

Stanchion Kit — N

Actual Height	Nominal Height	Width	Number ①	Trim A	B
No Accessory Slot (L or R)					
9.91"(252mm)	10"(254mm)	48"(1219mm)	QUSS-1048-NE	\$409.19	\$430.76
		54"(1372mm)	QUSS-1054-NE	412.40	435.51
		60"(1524mm)	QUSS-1060-NE	415.61	440.27
		66"(1676mm)	QUSS-1066-NE	418.82	445.02
		72"(1829mm)	QUSS-1072-NE	422.03	449.77
11.25"(286mm)	11"(279mm)	48"(1219mm)	QUSS-1148-NM	\$420.97	\$445.47
		54"(1372mm)	QUSS-1154-NM	424.18	450.43
		60"(1524mm)	QUSS-1160-NM	427.39	455.39
		66"(1676mm)	QUSS-1166-NM	430.60	460.35
		72"(1829mm)	QUSS-1172-NM	433.81	465.31
11.91"(303mm)	12"(305mm)	48"(1219mm)	QUSS-1248-NN	\$432.75	\$458.67
		54"(1372mm)	QUSS-1254-NN	435.96	463.74
		60"(1524mm)	QUSS-1260-NN	439.17	468.80
		66"(1676mm)	QUSS-1266-NN	442.38	473.86
		72"(1829mm)	QUSS-1272-NN	445.59	478.92
14.5"(368mm)	15"(381mm)	48"(1219mm)	QUSS-1548-NU	\$468.09	\$499.66
		54"(1372mm)	QUSS-1554-NU	471.30	505.13
		60"(1524mm)	QUSS-1560-NU	474.51	510.59
		66"(1676mm)	QUSS-1566-NU	477.72	516.06
		72"(1829mm)	QUSS-1572-NU	480.93	521.52
15.91"(404mm)	16"(406mm)	48"(1219mm)	QUSS-1648-NP	\$479.87	\$514.51
		54"(1372mm)	QUSS-1654-NP	483.08	520.20
		60"(1524mm)	QUSS-1660-NP	486.29	525.88
		66"(1676mm)	QUSS-1666-NP	489.50	531.57
		72"(1829mm)	QUSS-1672-NP	492.71	537.25
17.91"(455mm)	18"(457mm)	48"(1219mm)	QUSS-1848-NF	\$503.43	\$542.43
		54"(1372mm)	QUSS-1854-NF	506.64	548.42
		60"(1524mm)	QUSS-1860-NF	509.85	554.42
		66"(1676mm)	QUSS-1866-NF	513.06	560.41
		72"(1829mm)	QUSS-1872-NF	516.27	566.41

Stanchion Kit — P

Stanchion Kit — P

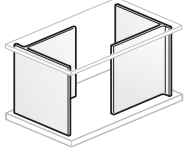
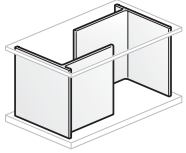

QUSS

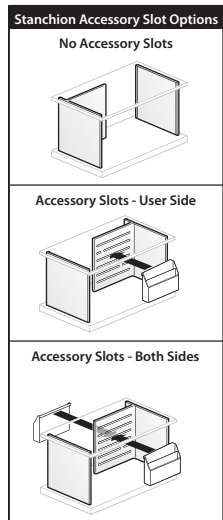

Features

- Includes stanchions and attachment hardware.
- For use with a single base unit or multiple base units of matching widths in a side-by-side application.
- Accessory Functionality:
 - A** User sided accessory slot for right hand stanchion.
 - B** User sided accessory slot for left hand stanchion.
 - C** User sided accessory slot for right and left hand stanchion.
 - D** Both side accessory slot for right hand stanchion.
 - E** Both side accessory slot for left hand stanchion.
 - F** Both side accessory slot for right and left hand stanchion.
 - N** No slots.
- Field assembled and installed.

Specification Tips

- User side is the inset side.
- Stanchion kits with separately specified shelves create a hutch which is designed to be used with a Beside base unit.
- A single stanchion kit can be used to support a Beside overhead storage unit. The combination of the Beside base unit, Stanchion kit and Overhead Storage or hutch shelf not to exceed 58”(1473mm).
- Binder Storage minimum height 15”(381mm).
- Refer to accessory price pages for stanchion height minimum requirement.
- Stanchion kits not available in widths greater than 72”(1829mm).
- Shelf must match width of the stanchion kit.
- Stanchion kits can be configured into multiple configurations.
- Refer to Specification Guide for planning information and actual dimensions.
- Stanchion Kit P can be applied in an in-line condition up to 42”(1067mm). Greater than 42”(1067mm) requires the product to be installed in a mirror image application.

To Order, Specify:

1) Product number, including:

① Accessory Slots Options:

User Side

- A** Right-Hand Stanchion
- B** Left-Hand Stanchion
- C** Right and Left Hand Stanchion

Both Sides

- D** Right-Hand Stanchion
- E** Left-Hand Stanchion
- F** Right and Left Hand Stanchion

No Accessory Slot

- N** No Slot

2) Painted color Stanchion Left.

3) Painted color Stanchion Right.

Note: Upcharge for mixed grade fabric or trim surfaces, refer to the electronic design and specification tools for pricing.

Stanchion Kit — P

Actual Height	Nominal Height	Width	Number ①	Trim A	B
Accessory Slot — User Side (A or B)					
9.91"(252mm)	10"(254mm)	24"(610mm)	QUSS-1024-PE	\$414.56	\$433.06
		30"(762mm)	QUSS-1030-PE	424.19	445.77
		36"(914mm)	QUSS-1036-PE	433.82	458.48
		42"(1067mm)	QUSS-1042-PE	443.45	471.19
		48"(1219mm)	QUSS-1048-PE	453.08	483.90
		54"(1372mm)	QUSS-1054-PE	462.71	496.61
		60"(1524mm)	QUSS-1060-PE	472.34	509.34
		66"(1676mm)	QUSS-1066-PE	481.97	522.05
		72"(1829mm)	QUSS-1072-PE	491.60	534.76
		11.25"(286mm)	11"(279mm)	24"(610mm)	QUSS-1124-PM
30"(762mm)	QUSS-1130-PM			438.12	462.62
36"(914mm)	QUSS-1136-PM			447.75	475.75
42"(1067mm)	QUSS-1142-PM			457.38	488.88
48"(1219mm)	QUSS-1148-PM			467.01	502.01
54"(1372mm)	QUSS-1154-PM			476.64	515.14
60"(1524mm)	QUSS-1160-PM			486.27	528.27
66"(1676mm)	QUSS-1166-PM			495.90	541.40
72"(1829mm)	QUSS-1172-PM			505.53	554.53
11.91"(303mm)	12"(305mm)			24"(610mm)	QUSS-1224-PN
		30"(762mm)	QUSS-1230-PN	452.05	477.99
		36"(914mm)	QUSS-1236-PN	461.68	491.32
		42"(1067mm)	QUSS-1242-PN	471.31	504.65
		48"(1219mm)	QUSS-1248-PN	480.94	517.98
		54"(1372mm)	QUSS-1254-PN	490.57	531.33
		60"(1524mm)	QUSS-1260-PN	500.20	544.66
		66"(1676mm)	QUSS-1266-PN	509.83	557.99
		72"(1829mm)	QUSS-1272-PN	519.46	571.32
		14.5"(368mm)	15"(381mm)	24"(610mm)	QUSS-1524-PU
30"(762mm)	QUSS-1530-PU			493.84	525.42
36"(914mm)	QUSS-1536-PU			503.47	539.55
42"(1067mm)	QUSS-1542-PU			513.10	553.70
48"(1219mm)	QUSS-1548-PU			522.73	567.83
54"(1372mm)	QUSS-1554-PU			532.36	581.98
60"(1524mm)	QUSS-1560-PU			541.99	596.11
66"(1676mm)	QUSS-1566-PU			551.62	610.26
72"(1829mm)	QUSS-1572-PU			561.25	624.39
15.91"(404mm)	16"(406mm)			24"(610mm)	QUSS-1624-PP
		30"(762mm)	QUSS-1630-PP	507.77	542.41
		36"(914mm)	QUSS-1636-PP	517.40	557.00
		42"(1067mm)	QUSS-1642-PP	527.03	571.57
		48"(1219mm)	QUSS-1648-PP	536.66	586.14
		54"(1372mm)	QUSS-1654-PP	546.29	600.73
		60"(1524mm)	QUSS-1660-PP	555.92	615.30
		66"(1676mm)	QUSS-1666-PP	565.55	629.89
		72"(1829mm)	QUSS-1672-PP	575.18	644.46
		17.91"(455mm)	18"(457mm)	24"(610mm)	QUSS-1824-PF
30"(762mm)	QUSS-1830-PF			535.63	574.63
36"(914mm)	QUSS-1836-PF			545.26	589.82
42"(1067mm)	QUSS-1842-PF			554.89	605.03
48"(1219mm)	QUSS-1848-PF			564.52	620.24
54"(1372mm)	QUSS-1854-PF			574.15	635.43
60"(1524mm)	QUSS-1860-PF			583.78	650.64
66"(1676mm)	QUSS-1866-PF			593.41	665.83
72"(1829mm)	QUSS-1872-PF			603.04	681.04

Stanchion Kit — P

Actual Height	Nominal Height	Width	Number	Trim A	B
Accessory Slot — User Side Right and Left-hand Stanchion (C)					
9.91"(252mm)	10"(254mm)	24"(610mm)	QUSS-1024-PEC	\$443.48	\$461.98
		30"(762mm)	QUSS-1030-PEC	456.32	477.90
		36"(914mm)	QUSS-1036-PEC	469.16	493.82
		42"(1067mm)	QUSS-1042-PEC	482.00	509.74
		48"(1219mm)	QUSS-1048-PEC	494.84	525.66
		54"(1372mm)	QUSS-1054-PEC	507.68	541.58
		60"(1524mm)	QUSS-1060-PEC	520.52	557.52
		66"(1676mm)	QUSS-1066-PEC	533.36	573.44
11.25"(286mm)	11"(279mm)	72"(1829mm)	QUSS-1072-PEC	546.20	589.36
		24"(610mm)	QUSS-1124-PMC	\$460.62	\$481.62
		30"(762mm)	QUSS-1130-PMC	473.46	497.96
		36"(914mm)	QUSS-1136-PMC	486.30	514.30
		42"(1067mm)	QUSS-1142-PMC	499.14	530.64
		48"(1219mm)	QUSS-1148-PMC	511.98	546.98
		54"(1372mm)	QUSS-1154-PMC	524.82	563.32
		60"(1524mm)	QUSS-1160-PMC	537.66	579.66
11.91"(303mm)	12"(305mm)	66"(1676mm)	QUSS-1166-PMC	550.50	596.00
		72"(1829mm)	QUSS-1172-PMC	563.34	612.34
		24"(610mm)	QUSS-1224-PNC	\$477.76	\$499.98
		30"(762mm)	QUSS-1230-PNC	490.60	516.54
		36"(914mm)	QUSS-1236-PNC	503.44	533.08
		42"(1067mm)	QUSS-1242-PNC	516.28	549.62
		48"(1219mm)	QUSS-1248-PNC	529.12	566.16
		54"(1372mm)	QUSS-1254-PNC	541.96	582.72
14.5"(368mm)	15"(381mm)	60"(1524mm)	QUSS-1260-PNC	554.80	599.26
		66"(1676mm)	QUSS-1266-PNC	567.64	615.80
		72"(1829mm)	QUSS-1272-PNC	580.48	632.34
		24"(610mm)	QUSS-1524-PUC	\$529.18	\$556.24
		30"(762mm)	QUSS-1530-PUC	542.02	573.60
		36"(914mm)	QUSS-1536-PUC	554.86	590.94
		42"(1067mm)	QUSS-1542-PUC	567.70	608.30
		48"(1219mm)	QUSS-1548-PUC	580.54	625.64
15.91"(404mm)	16"(406mm)	54"(1372mm)	QUSS-1554-PUC	593.38	643.00
		60"(1524mm)	QUSS-1560-PUC	606.22	660.34
		66"(1676mm)	QUSS-1566-PUC	619.06	677.70
		72"(1829mm)	QUSS-1572-PUC	631.90	695.04
		24"(610mm)	QUSS-1624-PPC	\$546.32	\$576.02
		30"(762mm)	QUSS-1630-PPC	559.16	593.80
		36"(914mm)	QUSS-1636-PPC	572.00	611.60
		42"(1067mm)	QUSS-1642-PPC	584.84	629.38
17.91"(455mm)	18"(457mm)	48"(1219mm)	QUSS-1648-PPC	597.68	647.16
		54"(1372mm)	QUSS-1654-PPC	610.52	664.96
		60"(1524mm)	QUSS-1660-PPC	623.36	682.74
		66"(1676mm)	QUSS-1666-PPC	636.20	700.54
		72"(1829mm)	QUSS-1672-PPC	649.04	718.32
		24"(610mm)	QUSS-1824-PFC	\$580.60	\$614.02
		30"(762mm)	QUSS-1830-PFC	593.44	632.44
		36"(914mm)	QUSS-1836-PFC	606.28	650.84
17.91"(455mm)	18"(457mm)	42"(1067mm)	QUSS-1842-PFC	619.12	669.26
		48"(1219mm)	QUSS-1848-PFC	631.96	687.68
		54"(1372mm)	QUSS-1854-PFC	644.80	706.08
		60"(1524mm)	QUSS-1860-PFC	657.64	724.50
		66"(1676mm)	QUSS-1866-PFC	670.48	742.90
		72"(1829mm)	QUSS-1872-PFC	683.32	761.32

Stanchion Kit — P

Actual Height	Nominal Height	Width	Number ①	Trim A	B
Accessory slot — Both Sides (D or E)					
9.91"(252mm)	10"(254mm)	24"(610mm)	QUSS-1024-PE	\$443.48	\$461.98
		30"(762mm)	QUSS-1030-PE	456.32	477.90
		36"(914mm)	QUSS-1036-PE	469.16	493.82
		42"(1067mm)	QUSS-1042-PE	482.00	509.74
		48"(1219mm)	QUSS-1048-PE	494.84	525.66
		54"(1372mm)	QUSS-1054-PE	507.68	541.58
		60"(1524mm)	QUSS-1060-PE	520.52	557.52
		66"(1676mm)	QUSS-1066-PE	533.36	573.44
		72"(1829mm)	QUSS-1072-PE	546.20	589.36
		11.25"(286mm)	11"(279mm)	24"(610mm)	QUSS-1124-PM
30"(762mm)	QUSS-1130-PM			473.46	497.96
36"(914mm)	QUSS-1136-PM			486.30	514.30
42"(1067mm)	QUSS-1142-PM			499.14	530.64
48"(1219mm)	QUSS-1148-PM			511.98	546.98
54"(1372mm)	QUSS-1154-PM			524.82	563.32
60"(1524mm)	QUSS-1160-PM			537.66	579.66
66"(1676mm)	QUSS-1166-PM			550.50	596.00
72"(1829mm)	QUSS-1172-PM			563.34	612.34
11.91"(303mm)	12"(305mm)			24"(610mm)	QUSS-1224-PN
		30"(762mm)	QUSS-1230-PN	490.60	516.54
		36"(914mm)	QUSS-1236-PN	503.44	533.08
		42"(1067mm)	QUSS-1242-PN	516.28	549.62
		48"(1219mm)	QUSS-1248-PN	529.12	566.16
		54"(1372mm)	QUSS-1254-PN	541.96	582.72
		60"(1524mm)	QUSS-1260-PN	554.80	599.26
		66"(1676mm)	QUSS-1266-PN	567.64	615.80
		72"(1829mm)	QUSS-1272-PN	580.48	632.34
		14.5"(368mm)	15"(381mm)	24"(610mm)	QUSS-1524-PU
30"(762mm)	QUSS-1530-PU			542.02	573.60
36"(914mm)	QUSS-1536-PU			554.86	590.94
42"(1067mm)	QUSS-1542-PU			567.70	608.30
48"(1219mm)	QUSS-1548-PU			580.54	625.64
54"(1372mm)	QUSS-1554-PU			593.38	643.00
60"(1524mm)	QUSS-1560-PU			606.22	660.34
66"(1676mm)	QUSS-1566-PU			619.06	677.70
72"(1829mm)	QUSS-1572-PU			631.90	695.04
15.91"(404mm)	16"(406mm)			24"(610mm)	QUSS-1624-PP
		30"(762mm)	QUSS-1630-PP	559.16	593.80
		36"(914mm)	QUSS-1636-PP	572.00	611.60
		42"(1067mm)	QUSS-1642-PP	584.84	629.38
		48"(1219mm)	QUSS-1648-PP	597.68	647.16
		54"(1372mm)	QUSS-1654-PP	610.52	664.96
		60"(1524mm)	QUSS-1660-PP	623.36	682.74
		66"(1676mm)	QUSS-1666-PP	636.20	700.54
		72"(1829mm)	QUSS-1672-PP	649.04	718.32
		17.91"(455mm)	18"(457mm)	24"(610mm)	QUSS-1824-PF
30"(762mm)	QUSS-1830-PF			593.44	632.44
36"(914mm)	QUSS-1836-PF			606.28	650.84
42"(1067mm)	QUSS-1842-PF			619.12	669.26
48"(1219mm)	QUSS-1848-PF			631.96	687.68
54"(1372mm)	QUSS-1854-PF			644.80	706.08
60"(1524mm)	QUSS-1860-PF			657.64	724.50
66"(1676mm)	QUSS-1866-PF			670.48	742.90
72"(1829mm)	QUSS-1872-PF			683.32	761.32

Stanchion Kit — P

Actual Height	Nominal Height	Width	Number	Trim A	B
Accessory Slot — Both Sides Right and Left-hand Stanchion (F)					
9.91"(252mm)	10"(254mm)	24"(610mm)	QUSS-1024-PEF	\$501.32	\$519.82
		30"(762mm)	QUSS-1030-PEF	520.58	542.16
		36"(914mm)	QUSS-1036-PEF	539.84	564.50
		42"(1067mm)	QUSS-1042-PEF	559.10	586.84
		48"(1219mm)	QUSS-1048-PEF	578.36	609.18
		54"(1372mm)	QUSS-1054-PEF	597.62	631.52
		60"(1524mm)	QUSS-1060-PEF	616.88	653.88
		66"(1676mm)	QUSS-1066-PEF	636.14	676.22
11.25"(286mm)	11"(279mm)	72"(1829mm)	QUSS-1072-PEF	655.40	698.56
		24"(610mm)	QUSS-1124-PMF	\$524.88	\$545.88
		30"(762mm)	QUSS-1130-PMF	544.14	568.64
		36"(914mm)	QUSS-1136-PMF	563.40	591.40
		42"(1067mm)	QUSS-1142-PMF	582.66	614.16
		48"(1219mm)	QUSS-1148-PMF	601.92	636.92
		54"(1372mm)	QUSS-1154-PMF	621.18	659.68
		60"(1524mm)	QUSS-1160-PMF	640.44	682.44
11.91"(303mm)	12"(305mm)	66"(1676mm)	QUSS-1166-PMF	659.70	705.20
		72"(1829mm)	QUSS-1172-PMF	678.96	727.96
		24"(610mm)	QUSS-1224-PNF	\$548.44	\$570.66
		30"(762mm)	QUSS-1230-PNF	567.70	593.64
		36"(914mm)	QUSS-1236-PNF	586.96	616.60
		42"(1067mm)	QUSS-1242-PNF	606.22	639.56
		48"(1219mm)	QUSS-1248-PNF	625.48	662.52
		54"(1372mm)	QUSS-1254-PNF	644.74	685.50
14.5"(368mm)	15"(381mm)	60"(1524mm)	QUSS-1260-PNF	664.00	708.46
		66"(1676mm)	QUSS-1266-PNF	683.26	731.42
		72"(1829mm)	QUSS-1272-PNF	702.52	754.38
		24"(610mm)	QUSS-1524-PUF	\$619.12	\$646.18
		30"(762mm)	QUSS-1530-PUF	638.38	669.96
		36"(914mm)	QUSS-1536-PUF	657.64	693.72
		42"(1067mm)	QUSS-1542-PUF	676.90	717.50
		48"(1219mm)	QUSS-1548-PUF	696.16	741.26
15.91"(404mm)	16"(406mm)	54"(1372mm)	QUSS-1554-PUF	715.42	765.04
		60"(1524mm)	QUSS-1560-PUF	734.68	788.80
		66"(1676mm)	QUSS-1566-PUF	753.94	812.58
		72"(1829mm)	QUSS-1572-PUF	773.20	836.34
		24"(610mm)	QUSS-1624-PPF	\$642.68	\$672.38
		30"(762mm)	QUSS-1630-PPF	661.94	696.58
		36"(914mm)	QUSS-1636-PPF	681.20	720.80
		42"(1067mm)	QUSS-1642-PPF	700.46	745.00
17.91"(455mm)	18"(457mm)	48"(1219mm)	QUSS-1648-PPF	719.72	769.20
		54"(1372mm)	QUSS-1654-PPF	738.98	793.42
		60"(1524mm)	QUSS-1660-PPF	758.24	817.62
		66"(1676mm)	QUSS-1666-PPF	777.50	841.84
		72"(1829mm)	QUSS-1672-PPF	796.76	866.04
		24"(610mm)	QUSS-1824-PFF	\$689.80	\$723.22
		30"(762mm)	QUSS-1830-PFF	709.06	748.06
		36"(914mm)	QUSS-1836-PFF	728.32	772.88
17.91"(455mm)	18"(457mm)	42"(1067mm)	QUSS-1842-PFF	747.58	797.72
		48"(1219mm)	QUSS-1848-PFF	766.84	822.56
		54"(1372mm)	QUSS-1854-PFF	786.10	847.38
		60"(1524mm)	QUSS-1860-PFF	805.36	872.22
		66"(1676mm)	QUSS-1866-PFF	824.62	897.04
		72"(1829mm)	QUSS-1872-PFF	843.88	921.88

Stanchion Kit — P

	Actual Height	Nominal Height	Width	Number	Trim A	B
No Slots						
	9.91"(252mm)	10"(254mm)	24"(610mm)	QUSS-1024-PEN	\$385.64	\$404.14
			30"(762mm)	QUSS-1030-PEN	392.06	413.64
			36"(914mm)	QUSS-1036-PEN	398.48	423.14
			42"(1067mm)	QUSS-1042-PEN	404.90	432.64
			48"(1219mm)	QUSS-1048-PEN	411.32	442.14
			54"(1372mm)	QUSS-1054-PEN	417.74	451.64
			60"(1524mm)	QUSS-1060-PEN	424.16	461.16
			66"(1676mm)	QUSS-1066-PEN	430.58	470.66
			72"(1829mm)	QUSS-1072-PEN	437.00	480.16
	11.25"(286mm)	11"(279mm)	24"(610mm)	QUSS-1124-PMN	\$396.36	\$417.36
			30"(762mm)	QUSS-1130-PMN	402.78	427.28
			36"(914mm)	QUSS-1136-PMN	409.20	437.20
			42"(1067mm)	QUSS-1142-PMN	415.62	447.12
			48"(1219mm)	QUSS-1148-PMN	422.04	457.04
			54"(1372mm)	QUSS-1154-PMN	428.46	466.96
			60"(1524mm)	QUSS-1160-PMN	434.88	476.88
			66"(1676mm)	QUSS-1166-PMN	441.30	486.80
			72"(1829mm)	QUSS-1172-PMN	447.72	496.72
	11.91"(303mm)	12"(305mm)	24"(610mm)	QUSS-1224-PNN	\$407.08	\$429.30
			30"(762mm)	QUSS-1230-PNN	413.50	439.44
			36"(914mm)	QUSS-1236-PNN	419.92	449.56
			42"(1067mm)	QUSS-1242-PNN	426.34	459.68
			48"(1219mm)	QUSS-1248-PNN	432.76	469.80
			54"(1372mm)	QUSS-1254-PNN	439.18	479.94
			60"(1524mm)	QUSS-1260-PNN	445.60	490.06
			66"(1676mm)	QUSS-1266-PNN	452.02	500.18
			72"(1829mm)	QUSS-1272-PNN	458.44	510.30
	14.5"(368mm)	15"(381mm)	24"(610mm)	QUSS-1524-PUN	\$439.24	\$466.30
			30"(762mm)	QUSS-1530-PUN	445.66	477.24
			36"(914mm)	QUSS-1536-PUN	452.08	488.16
			42"(1067mm)	QUSS-1542-PUN	458.50	499.10
			48"(1219mm)	QUSS-1548-PUN	464.92	510.02
			54"(1372mm)	QUSS-1554-PUN	471.34	520.96
			60"(1524mm)	QUSS-1560-PUN	477.76	531.88
			66"(1676mm)	QUSS-1566-PUN	484.18	542.82
			72"(1829mm)	QUSS-1572-PUN	490.60	553.74
	15.91"(404mm)	16"(406mm)	24"(610mm)	QUSS-1624-PPN	\$449.96	\$479.66
			30"(762mm)	QUSS-1630-PPN	456.38	491.02
			36"(914mm)	QUSS-1636-PPN	462.80	502.40
			42"(1067mm)	QUSS-1642-PPN	469.22	513.76
			48"(1219mm)	QUSS-1648-PPN	475.64	525.12
			54"(1372mm)	QUSS-1654-PPN	482.06	536.50
			60"(1524mm)	QUSS-1660-PPN	488.48	547.86
			66"(1676mm)	QUSS-1666-PPN	494.90	559.24
			72"(1829mm)	QUSS-1672-PPN	501.32	570.60
	17.91"(455mm)	18"(457mm)	24"(610mm)	QUSS-1824-PFN	\$471.40	\$504.82
			30"(762mm)	QUSS-1830-PFN	477.82	516.82
			36"(914mm)	QUSS-1836-PFN	484.24	528.80
			42"(1067mm)	QUSS-1842-PFN	490.66	540.80
			48"(1219mm)	QUSS-1848-PFN	497.08	552.80
			54"(1372mm)	QUSS-1854-PFN	503.50	564.78
			60"(1524mm)	QUSS-1860-PFN	509.92	576.78
			66"(1676mm)	QUSS-1866-PFN	516.34	588.76
			72"(1829mm)	QUSS-1872-PFN	522.76	600.76

Stanchion Kit — Q

Stanchion Kit — Q

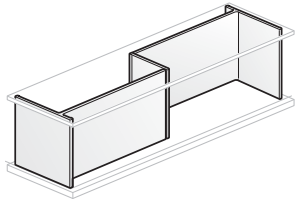
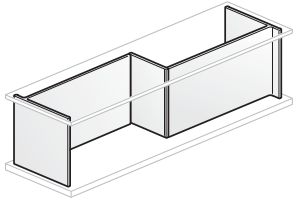
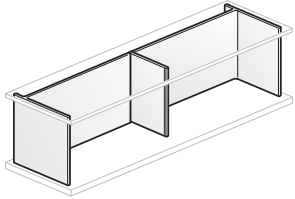

QUSS

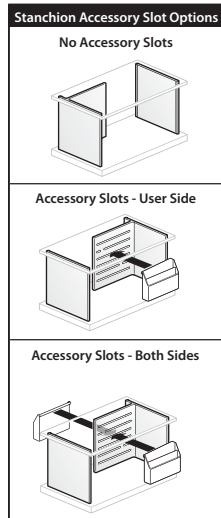

Features

- Includes stanchions and attachment hardware.
- For use with a single base unit or multiple base units of matching widths in a side-by-side application.
- Accessory Functionality:
 - A** User sided accessory slot for right hand stanchion.
 - B** User sided accessory slot for left hand stanchion.
 - C** User side accessory slot for right and left hand stanchion.
 - D** Both side accessory slot for right hand stanchion.
 - E** Both side accessory slot for left hand stanchion.
 - F** Both side accessory slot for right and left hand stanchion.
 - N** No slots.
- Field assembled and installed.

Specification Tips

- User side is the inset side.
- Stanchion kits with separately specified shelves create a hutch which is designed to be used with a Beside base unit.
- A single stanchion kit can be used to support a Beside overhead storage unit. The combination of the Beside base unit, Stanchion kit and Overhead Storage or hutch shelf not to exceed 58”(1473mm).
- Binder Storage minimum height 15”(381mm).
- Refer to accessory price pages for stanchion height minimum requirement.
- Stanchion kits not available in widths greater than 72”(1829mm).
- Shelf must match width of the stanchion kit.
- Stanchion kits can be configured into multiple configurations.
- Refer to Specification Guide for planning information and actual dimensions.

To Order, Specify:

- 1) Product number, including:

① Accessory Slots Options:

User Side

- A** Right-Hand Stanchion
- B** Left-Hand Stanchion
- C** Right and Left Hand Stanchion

Both Sides

- D** Right-Hand Stanchion
- E** Left-Hand Stanchion
- F** Right and Left Hand Stanchion

No Accessory Slot

- N** No Slot

- 2) Painted color Stanchion Left.
- 3) Painted color Stanchion Right.
- 4) Painted color Center Divider (for widths 48”(1219mm) and higher).

Note: Upcharge for mixed grade fabric or trim surfaces, refer to the electronic design and specification tools for pricing.

Stanchion Kit — Q

Actual Height	Nominal Height	Width	Number ①	Trim A	B		
Accessory Slot — User Side (A or B)							
9.91"(252mm)	10"(254mm)	48"(1219mm)	QUSS-1048-QE	\$506.64	\$540.54		
		54"(1372mm)	QUSS-1054-QE	516.27	553.25		
		60"(1524mm)	QUSS-1060-QE	525.90	565.98		
		66"(1676mm)	QUSS-1066-QE	535.53	578.69		
11.25"(286mm)	11"(279mm)	72"(1829mm)	QUSS-1072-QE	545.16	591.40		
		48"(1219mm)	QUSS-1148-QM	\$523.78	\$562.28		
		54"(1372mm)	QUSS-1154-QM	533.41	575.41		
		60"(1524mm)	QUSS-1160-QM	543.04	588.54		
11.91"(303mm)	12"(305mm)	66"(1676mm)	QUSS-1166-QM	552.67	601.67		
		72"(1829mm)	QUSS-1172-QM	562.30	614.80		
		48"(1219mm)	QUSS-1248-QN	\$540.92	\$581.66		
		54"(1372mm)	QUSS-1254-QN	550.55	595.01		
14.5"(368mm)	15"(381mm)	60"(1524mm)	QUSS-1260-QN	560.18	608.34		
		66"(1676mm)	QUSS-1266-QN	569.81	621.67		
		72"(1829mm)	QUSS-1272-QN	579.44	635.00		
		48"(1219mm)	QUSS-1548-QU	\$592.34	\$641.95		
15.91"(404mm)	16"(406mm)	54"(1372mm)	QUSS-1554-QU	601.97	656.10		
		60"(1524mm)	QUSS-1560-QU	611.60	670.23		
		66"(1676mm)	QUSS-1566-QU	621.23	684.38		
		72"(1829mm)	QUSS-1572-QU	630.86	698.51		
17.91"(455mm)	18"(457mm)	48"(1219mm)	QUSS-1648-QP	\$609.48	\$663.91		
		54"(1372mm)	QUSS-1654-QP	619.11	678.50		
		60"(1524mm)	QUSS-1660-QP	628.74	693.07		
		66"(1676mm)	QUSS-1666-QP	638.37	707.66		
17.91"(455mm)	18"(457mm)	72"(1829mm)	QUSS-1672-QP	648.00	722.23		
		48"(1219mm)	QUSS-1848-QF	\$643.76	\$705.05		
		54"(1372mm)	QUSS-1854-QF	653.39	720.24		
		60"(1524mm)	QUSS-1860-QF	663.02	735.45		
17.91"(455mm)	18"(457mm)	66"(1676mm)	QUSS-1866-QF	672.65	750.64		
		72"(1829mm)	QUSS-1872-QF	682.28	765.85		
		Accessory Slot — User Side Right and Left-hand Stanchion (C)					
		9.91"(252mm)	10"(254mm)	48"(1219mm)	QUSS-1048-QEC	\$548.40	\$582.30
54"(1372mm)	QUSS-1054-QEC			561.24	598.22		
60"(1524mm)	QUSS-1060-QEC			574.08	614.16		
66"(1676mm)	QUSS-1066-QEC			586.92	630.08		
11.25"(286mm)	11"(279mm)	72"(1829mm)	QUSS-1072-QEC	599.76	646.00		
		48"(1219mm)	QUSS-1148-QMC	\$568.75	\$607.25		
		54"(1372mm)	QUSS-1154-QMC	581.59	623.59		
		60"(1524mm)	QUSS-1160-QMC	594.43	639.93		
11.91"(303mm)	12"(305mm)	66"(1676mm)	QUSS-1166-QMC	607.27	656.27		
		72"(1829mm)	QUSS-1172-QMC	620.11	672.61		
		48"(1219mm)	QUSS-1248-QNC	\$589.10	\$629.84		
		54"(1372mm)	QUSS-1254-QNC	601.94	646.40		
14.5"(368mm)	15"(381mm)	60"(1524mm)	QUSS-1260-QNC	614.78	662.94		
		66"(1676mm)	QUSS-1266-QNC	627.62	679.48		
		72"(1829mm)	QUSS-1272-QNC	640.46	696.02		
		48"(1219mm)	QUSS-1548-QUC	\$650.15	\$699.76		
15.91"(404mm)	16"(406mm)	54"(1372mm)	QUSS-1554-QUC	662.99	717.12		
		60"(1524mm)	QUSS-1560-QUC	675.83	734.46		
		66"(1676mm)	QUSS-1566-QUC	688.67	751.82		
		72"(1829mm)	QUSS-1572-QUC	701.51	769.16		
17.91"(455mm)	18"(457mm)	48"(1219mm)	QUSS-1648-QPC	\$670.50	\$724.93		
		54"(1372mm)	QUSS-1654-QPC	683.34	742.73		
		60"(1524mm)	QUSS-1660-QPC	696.18	760.51		
		66"(1676mm)	QUSS-1666-QPC	709.02	778.31		
17.91"(455mm)	18"(457mm)	72"(1829mm)	QUSS-1672-QPC	721.86	796.09		
		48"(1219mm)	QUSS-1848-QFC	\$711.20	\$772.49		
		54"(1372mm)	QUSS-1854-QFC	724.04	790.89		
		60"(1524mm)	QUSS-1860-QFC	736.88	809.31		
17.91"(455mm)	18"(457mm)	66"(1676mm)	QUSS-1866-QFC	749.72	827.71		
		72"(1829mm)	QUSS-1872-QFC	762.56	846.13		

Stanchion Kit — Q

Actual Height	Nominal Height	Width	Number ^①	Trim A	B
Accessory Slot — Both Sides (D or E)					
9.91"(252mm)	10"(254mm)	48"(1219mm)	QUSS-1048-QE	\$548.40	\$582.30
		54"(1372mm)	QUSS-1054-QE	561.24	598.22
		60"(1524mm)	QUSS-1060-QE	574.08	614.16
		66"(1676mm)	QUSS-1066-QE	586.92	630.08
		72"(1829mm)	QUSS-1072-QE	599.76	646.00
11.25"(286mm)	11"(279mm)	48"(1219mm)	QUSS-1148-QM	\$568.75	\$607.25
		54"(1372mm)	QUSS-1154-QM	581.59	623.59
		60"(1524mm)	QUSS-1160-QM	594.43	639.93
		66"(1676mm)	QUSS-1166-QM	607.27	656.27
		72"(1829mm)	QUSS-1172-QM	620.11	672.61
11.91"(303mm)	12"(305mm)	48"(1219mm)	QUSS-1248-QN	589.10	629.84
		54"(1372mm)	QUSS-1254-QN	601.94	646.40
		60"(1524mm)	QUSS-1260-QN	614.78	662.94
		66"(1676mm)	QUSS-1266-QN	627.62	679.48
		72"(1829mm)	QUSS-1272-QN	640.46	696.02
14.5"(368mm)	15"(381mm)	48"(1219mm)	QUSS-1548-QU	\$650.15	\$699.76
		54"(1372mm)	QUSS-1554-QU	662.99	717.12
		60"(1524mm)	QUSS-1560-QU	675.83	734.46
		66"(1676mm)	QUSS-1566-QU	688.67	751.82
		72"(1829mm)	QUSS-1572-QU	701.51	769.16
15.91"(404mm)	16"(406mm)	48"(1219mm)	QUSS-1648-QP	\$670.50	\$724.93
		54"(1372mm)	QUSS-1654-QP	683.34	742.73
		60"(1524mm)	QUSS-1660-QP	696.18	760.51
		66"(1676mm)	QUSS-1666-QP	709.02	778.31
		72"(1829mm)	QUSS-1672-QP	721.86	796.09
17.91"(455mm)	18"(457mm)	48"(1219mm)	QUSS-1848-QF	\$711.20	\$772.49
		54"(1372mm)	QUSS-1854-QF	724.04	790.89
		60"(1524mm)	QUSS-1860-QF	736.88	809.31
		66"(1676mm)	QUSS-1866-QF	749.72	827.71
		72"(1829mm)	QUSS-1872-QF	762.56	846.13

Stanchion Kit — Q

Actual Height	Nominal Height	Width	Number	Trim A	B
Accessory Slot — Both Sides Right and Left-hand Stanchion (F)					
9.91"(252mm)	10"(254mm)	48"(1219mm)	QUSS-1048-QEF	\$631.92	\$ 665.82
		54"(1372mm)	QUSS-1054-QEF	651.18	688.16
		60"(1524mm)	QUSS-1060-QEF	670.44	710.52
		66"(1676mm)	QUSS-1066-QEF	689.70	732.86
		72"(1829mm)	QUSS-1072-QEF	708.96	755.20
11.25"(286mm)	11"(279mm)	48"(1219mm)	QUSS-1148-QMF	\$658.69	\$ 697.19
		54"(1372mm)	QUSS-1154-QMF	677.95	719.95
		60"(1524mm)	QUSS-1160-QMF	697.21	742.71
		66"(1676mm)	QUSS-1166-QMF	716.47	765.47
		72"(1829mm)	QUSS-1172-QMF	735.73	788.23
11.91"(303mm)	12"(305mm)	48"(1219mm)	QUSS-1248-QNF	\$685.46	\$ 726.20
		54"(1372mm)	QUSS-1254-QNF	704.72	749.18
		60"(1524mm)	QUSS-1260-QNF	723.98	772.14
		66"(1676mm)	QUSS-1266-QNF	743.24	795.10
		72"(1829mm)	QUSS-1272-QNF	762.50	818.06
14.5"(368mm)	15"(381mm)	48"(1219mm)	QUSS-1548-QUF	\$765.77	\$ 815.38
		54"(1372mm)	QUSS-1554-QUF	785.03	839.16
		60"(1524mm)	QUSS-1560-QUF	804.29	862.92
		66"(1676mm)	QUSS-1566-QUF	823.55	886.70
		72"(1829mm)	QUSS-1572-QUF	842.81	910.46
15.91"(404mm)	16"(406mm)	48"(1219mm)	QUSS-1648-QPF	\$792.54	\$ 846.97
		54"(1372mm)	QUSS-1654-QPF	811.80	871.19
		60"(1524mm)	QUSS-1660-QPF	831.06	895.39
		66"(1676mm)	QUSS-1666-QPF	850.32	919.61
		72"(1829mm)	QUSS-1672-QPF	869.58	943.81
17.91"(455mm)	18"(457mm)	48"(1219mm)	QUSS-1848-QFF	\$846.08	\$ 907.37
		54"(1372mm)	QUSS-1854-QFF	865.34	932.19
		60"(1524mm)	QUSS-1860-QFF	884.60	957.03
		66"(1676mm)	QUSS-1866-QFF	903.86	981.85
		72"(1829mm)	QUSS-1872-QFF	923.12	1006.69
No Slots					
9.91"(252mm)	10"(254mm)	48"(1219mm)	QUSS-1048-QEN	\$464.88	\$ 498.78
		54"(1372mm)	QUSS-1054-QEN	471.30	508.28
		60"(1524mm)	QUSS-1060-QEN	477.72	517.80
		66"(1676mm)	QUSS-1066-QEN	484.14	527.30
		72"(1829mm)	QUSS-1072-QEN	490.56	536.80
11.25"(286mm)	11"(279mm)	48"(1219mm)	QUSS-1148-QMN	\$478.81	\$ 517.31
		54"(1372mm)	QUSS-1154-QMN	485.23	527.23
		60"(1524mm)	QUSS-1160-QMN	491.65	537.15
		66"(1676mm)	QUSS-1166-QMN	498.07	547.07
		72"(1829mm)	QUSS-1172-QMN	504.49	556.99
11.91"(303mm)	12"(305mm)	48"(1219mm)	QUSS-1248-QNN	\$492.74	\$ 533.48
		54"(1372mm)	QUSS-1254-QNN	499.16	543.62
		60"(1524mm)	QUSS-1260-QNN	505.58	553.74
		66"(1676mm)	QUSS-1266-QNN	512.00	563.86
		72"(1829mm)	QUSS-1272-QNN	518.42	573.98
14.5"(368mm)	15"(381mm)	48"(1219mm)	QUSS-1548-QUN	\$534.53	\$ 584.14
		54"(1372mm)	QUSS-1554-QUN	540.95	595.08
		60"(1524mm)	QUSS-1560-QUN	547.37	606.00
		66"(1676mm)	QUSS-1566-QUN	553.79	616.94
		72"(1829mm)	QUSS-1572-QUN	560.21	627.86
15.91"(404mm)	16"(406mm)	48"(1219mm)	QUSS-1648-QPN	\$548.46	\$ 602.89
		54"(1372mm)	QUSS-1654-QPN	554.88	614.27
		60"(1524mm)	QUSS-1660-QPN	561.30	625.63
		66"(1676mm)	QUSS-1666-QPN	567.72	637.01
		72"(1829mm)	QUSS-1672-QPN	574.14	648.37
17.91"(455mm)	18"(457mm)	48"(1219mm)	QUSS-1848-QFN	\$576.32	\$ 637.61
		54"(1372mm)	QUSS-1854-QFN	582.74	649.59
		60"(1524mm)	QUSS-1860-QFN	589.16	661.59
		66"(1676mm)	QUSS-1866-QFN	595.58	673.57
		72"(1829mm)	QUSS-1872-QFN	602.00	685.57

Accessories

	Nominal Depth	Nominal Width	Number ^①	Laminate		Wood Group	
				A	B	A	B
Hutch Shelf	16"(406mm)	24"(610mm)	QUHT-1624-	\$ 96.41	\$156.40	\$407.06	\$419.91
		30"(762mm)	QUHT-1630-	107.12	168.18	424.20	440.26
		36"(914mm)	QUHT-1636-	117.83	179.96	441.34	460.61
		42"(1067mm)	QUHT-1642-	128.54	191.74	458.48	480.96
		48"(1219mm)	QUHT-1648-	139.25	203.52	475.62	501.31
		54"(1372mm)	QUHT-1654-	149.96	215.30	492.76	521.66
		60"(1524mm)	QUHT-1660-	160.67	227.08	509.90	542.01
		66"(1676mm)	QUHT-1666-	171.38	238.86	527.04	562.36
		72"(1829mm)	QUHT-1672-	182.09	250.64	544.18	582.71

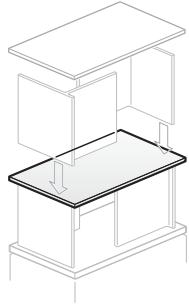

QUHT

Features

- Includes one 3/4"(19mm) shelf.
- Available in:
 - Laminate with 3mm edgeband on user edge and 1mm on sides and back.
 - Wood with 3mm edgeband on user edge with 1mm edgeband on sides and back.

Specification Tips

- For use with Beside Product only.
- Hutch application can be created with one stanchion and one shelf. Maximum stacking with base units, stanchion kits and shelves not to exceed 58"(1473mm).
- Shelves require separately specified stanchion kits.
- Shelves are not used in combination with a stanchion and a overhead.
- Shelves 48"(1219mm) or wider can only be used with Stanchion kits H, N, P and Q.
- Shelf must match width of stanchion kit.
- Separately specified Adaptable LED task light is designed to be attached to the underside of a hutch shelf.

To Order, Specify:

- 1) Product number, including:

① Shelf Surface:

- L Laminate
- W Wood

- 2) Laminate or Wood finish color.
- 3) Laminate edgeband color.

Overhead Storage Unit — Open

Single Sided Open

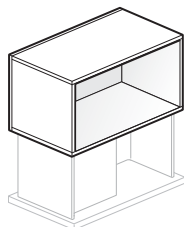

QUS1-XXXX-HXNNN

Height	Depth	Width	Number ①	Laminate		Wood Group	
				A	B	A	B
16"(406mm)	17.25"(438mm)	24"(610mm)	QUS1-1624-H NNN	\$1106.55	\$ 731.63	\$ 852.45	\$1119.40
		30"(762mm)	QUS1-1630-H NNN	1189.03	781.98	986.13	1191.17
		36"(914mm)	QUS1-1636-H NNN	1271.51	832.33	1119.81	1262.94
		42"(1067mm)	QUS1-1642-H NNN	1353.99	882.68	1253.49	1334.71
		48"(1219mm)	QUS1-1648-H NNN	1436.47	933.03	1387.17	1406.48
		54"(1372mm)	QUS1-1654-H NNN	1518.95	1045.51	1582.98	1544.66
		60"(1524mm)	QUS1-1660-H NNN	1667.84	1095.86	1716.66	1667.85
		66"(1676mm)	QUS1-1666-H NNN	1801.74	1174.06	1878.19	1778.18
		72"(1829mm)	QUS1-1672-H NNN	1922.78	792.94	798.30	888.28

Feature

- Includes one overhead storage unit.

Specification Tips

- Overhead Storage Unit can be stanchion mounted on Beside Base Units or top mounted on a system panel; cannot be wall mounted.
- When designing with separately specified stanchion kit no shelves required directly under overhead.
- Maximum stacking with a base unit, a stanchion kit and an overhead unit not to exceed 58"(1473mm). Maximum stacking with a panel and an overhead storage unit not of exceed 66"(1676mm).
- Accepts separately specified lighting.
- Doors are not designed to be retrofitted.
- Separately specified if applicable:
 - Stanchion Kit (hardware included)
 - Panel attachment hardware
- Beside overhead storage unit can be off-modular mounted on separately specified Compose aluminum top trim (UZCC) and PREMISE (QNGB-0000-PZ).

Note: Attachment hardware is application specific. See Specification Guide.

To Order, Specify:

- 1) Product number, including:

① Case Surface Option:

L Laminate

W Wood

- 2) Laminate or wood finish color.
- 3) Laminate edgeband color.

This page intentionally blank

Overhead Storage Unit — Hinged Doors — Laminate Case

Single Sided

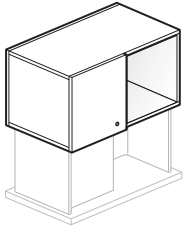

QUS1-XXXX-AXXNX
(Hinged Door left/Open Right)

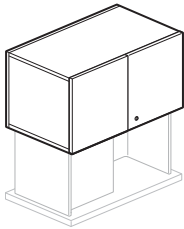

QUS1-XXXX-CXXNX
(Full Hinged Doors)

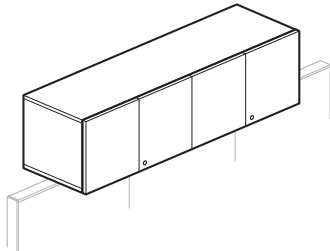

QUS1-XXXX-CXXNX
(Full Hinged Doors)

Features

- Includes overhead unit with laminate case and hinged doors (steel, laminate or wood with touch latch).
- Hinged doors require field assembly.
- Locking (chrome only) and non-locking options available; refer to Lock Program Price List.

Specification Tips

- Overhead Storage Unit can be stanchion mounted on Beside Base Units or top mounted on a system panel; cannot be wall mounted.
- When designing with separately specified stanchion kits no shelves required directly under overhead.
- Maximum stacking with a base unit, a stanchion kit and an overhead unit not to exceed 58" (1473mm). Maximum stacking with a panel and an overhead storage unit not to exceed 66" (1676mm).
- Accepts separately specified lighting.
- Doors are not designed to be retrofitted.
- Separately specified if applicable:
 - Stanchion Kit (hardware included)
 - Panel attachment hardware
- Beside overhead storage unit can be off-modular mounted on separately specified Compose aluminum top trim (UZCC) and PREMISE (QNGB-0000-PZ).

Notes:

Attachment hardware is application specific.
See Specification Guide.

24"-42" (610mm-1067mm) Full hinge units have two doors and one lock if specified.

48"-72" (1219mm-1829mm) Full hinge units have four doors and two locks if specified.

To Order, Specify:

1) Product number, including:

1 Door Material Option:

- S** Steel
- L** Laminate
- W** Wood

2 Lock Option:

- L** Locking, add **\$73.91** list
- N** Non-Locking

- 2) Case laminate color.
- 3) Case edgeband trim color.
- 4) Door material front color.
- 5) Door material front edgeband color with touch latch (laminate only).

Overhead Storage Unit — Hinged Doors — Laminate Case

Single Sided

Description	Outside Depth	Outside Width	Total Inside Width	Number	①	②	Case Laminate A		Laminate Door		Wood Door	
							Steel Door A	B	A	B	Group A	Group B
Hinged Door/Open Right												
	18"(457mm)	24"(610mm)	22.5"(572mm)	QUS1-1624-AL	■	N	\$ 895.78	\$1121.50	\$1178.27	\$ 850.51	\$ 856.94	\$ 955.49
		30"(762mm)	28.5"(724mm)	QUS1-1630-AL	■	N	964.06	1210.51	1272.63	908.08	915.58	1022.70
		36"(914mm)	34.5"(876mm)	QUS1-1636-AL	■	N	1032.34	1299.52	1366.99	965.65	974.22	1089.91
		42"(1067mm)	40.5"(1029mm)	QUS1-1642-AL	■	N	1100.62	1388.53	1461.35	1031.16	1040.80	1165.06
		48"(1219mm)	46.5"(1181mm)	QUS1-1648-AL	■	N	1176.84	1485.48	1563.65	1091.29	1102.00	1234.83
		54"(1372mm)	52.5"(1334mm)	QUS1-1654-AL	■	N	1247.68	1577.05	1660.57	1213.55	1225.33	1366.73
		60"(1524mm)	58.5"(1486mm)	QUS1-1660-AL	■	N	1380.65	1730.75	1819.62	1273.68	1286.53	1436.50
		66"(1676mm)	64.5"(1638mm)	QUS1-1666-AL	■	N	1451.49	1822.32	1916.54	1361.66	1375.58	1534.12
		72"(1829mm)	70.5"(1791mm)	QUS1-1672-AL	■	N	1550.18	1941.74	2041.31	792.94	798.30	888.28
Hinged Door/Open Left												
	18"(457mm)	24"(610mm)	22.5"(572mm)	QUS1-1624-BL	■	N	\$ 895.78	\$1121.50	\$1178.27	\$ 850.51	\$ 856.94	\$ 955.49
		30"(762mm)	28.5"(724mm)	QUS1-1630-BL	■	N	964.06	1210.51	1272.63	908.08	915.58	1022.70
		36"(914mm)	34.5"(876mm)	QUS1-1636-BL	■	N	1032.34	1299.52	1366.99	965.65	974.22	1089.91
		42"(1067mm)	40.5"(1029mm)	QUS1-1642-BL	■	N	1100.62	1388.53	1461.35	1031.16	1040.80	1165.06
		48"(1219mm)	46.5"(1181mm)	QUS1-1648-BL	■	N	1176.84	1485.48	1563.65	1091.29	1102.00	1234.83
		54"(1372mm)	52.5"(1334mm)	QUS1-1654-BL	■	N	1247.68	1577.05	1660.57	1213.55	1225.33	1366.73
		60"(1524mm)	58.5"(1486mm)	QUS1-1660-BL	■	N	1380.65	1730.75	1819.62	1273.68	1286.53	1436.50
		66"(1676mm)	64.5"(1638mm)	QUS1-1666-BL	■	N	1451.49	1822.32	1916.54	1361.66	1375.58	1534.12
		72"(1829mm)	70.5"(1791mm)	QUS1-1672-BL	■	N	1550.18	1941.74	2041.31	858.53	863.89	953.87
Full Hinged Doors												
	18"(457mm)	24"(610mm)	22.5"(572mm)	QUS1-1624-CL	■	N	\$ 961.37	\$1187.09	\$1243.86	\$ 935.09	\$ 941.52	\$1040.07
		30"(762mm)	28.5"(724mm)	QUS1-1630-CL	■	N	1048.64	1295.09	1357.21	1011.65	1019.15	1126.27
		36"(914mm)	34.5"(876mm)	QUS1-1636-CL	■	N	1135.91	1403.09	1470.56	1088.21	1096.78	1212.47
		42"(1067mm)	40.5"(1029mm)	QUS1-1642-CL	■	N	1223.18	1511.09	1583.91	1180.65	1190.29	1314.55
		48"(1219mm)	46.5"(1181mm)	QUS1-1648-CL	■	N	1326.33	1634.97	1713.14	1262.33	1273.04	1405.87
		54"(1372mm)	52.5"(1334mm)	QUS1-1654-CL	■	N	1418.72	1748.09	1831.61	1406.14	1417.92	1559.32
		60"(1524mm)	58.5"(1486mm)	QUS1-1660-CL	■	N	1573.24	1923.34	2012.21	1487.82	1500.67	1650.64
		66"(1676mm)	64.5"(1638mm)	QUS1-1666-CL	■	N	1665.63	2036.46	2130.68	1597.35	1611.27	1769.81
		72"(1829mm)	70.5"(1791mm)	QUS1-1672-CL	■	N	1785.87	2177.43	2277.00	830.43	835.79	925.77

Overhead Storage Unit — Hinged Doors — Laminate Case

Single Sided

Description	Outside Depth	Outside Width	Total Inside Width	Number	①	②	Case Laminate B		Laminate Door		Wood Door	
							Steel Door A	B	A	B	Group A	Group B
Hinged Door/Open Right												
18"(457mm)	24"(610mm)	22.5"(572mm)	QUS1-1624-AL	N			\$ 933.27	\$1158.99	\$1215.76	\$ 971.33	\$ 977.76	\$1076.31
	30"(762mm)	28.5"(724mm)	QUS1-1630-AL	N			1084.88	1331.33	1393.45	1112.23	1119.73	1226.85
	36"(914mm)	34.5"(876mm)	QUS1-1636-AL	N			1236.49	1503.67	1571.14	1253.13	1261.70	1377.39
	42"(1067mm)	40.5"(1029mm)	QUS1-1642-AL	N			1388.10	1676.01	1748.83	1401.97	1411.61	1535.87
	48"(1219mm)	46.5"(1181mm)	QUS1-1648-AL	N			1547.65	1856.29	1934.46	1545.43	1556.14	1688.97
	54"(1372mm)	52.5"(1334mm)	QUS1-1654-AL	N			1701.82	2031.19	2114.71	1751.02	1762.80	1904.20
	60"(1524mm)	58.5"(1486mm)	QUS1-1660-AL	N			1918.12	2268.22	2357.09	1894.48	1907.33	2072.29
	66"(1676mm)	64.5"(1638mm)	QUS1-1666-AL	N			2072.29	2443.12	2065.79	2065.79	2079.71	2238.25
	72"(1829mm)	70.5"(1791mm)	QUS1-1672-AL	N			2254.31	2645.87	2745.44	830.43	835.79	925.77
Hinged Door/Open Left												
18"(457mm)	24"(610mm)	22.5"(572mm)	QUS1-1624-BL	N			\$ 933.27	\$1158.99	\$1215.76	\$ 971.33	\$ 977.76	\$1076.31
	30"(762mm)	28.5"(724mm)	QUS1-1630-BL	N			1084.88	1331.33	1393.45	1112.23	1119.73	1226.85
	36"(914mm)	34.5"(876mm)	QUS1-1636-BL	N			1236.49	1503.67	1571.14	1253.13	1261.70	1377.39
	42"(1067mm)	40.5"(1029mm)	QUS1-1642-BL	N			1388.10	1676.01	1748.83	1401.97	1411.61	1535.87
	48"(1219mm)	46.5"(1181mm)	QUS1-1648-BL	N			1547.65	1856.29	1934.46	1545.43	1556.14	1688.97
	54"(1372mm)	52.5"(1334mm)	QUS1-1654-BL	N			1701.82	2031.19	2114.71	1751.02	1762.80	1904.20
	60"(1524mm)	58.5"(1486mm)	QUS1-1660-BL	N			1918.12	2268.22	2357.09	1894.48	1907.33	2057.30
	66"(1676mm)	64.5"(1638mm)	QUS1-1666-BL	N			2072.29	2443.12	2537.34	2065.79	2079.71	2238.25
	72"(1829mm)	70.5"(1791mm)	QUS1-1672-BL	N			2254.31	2645.87	2745.44	896.02	901.38	991.36
Full Hinged Doors												
18"(457mm)	24"(610mm)	22.5"(572mm)	QUS1-1624-CL	N			\$ 998.86	\$1224.58	\$1281.35	\$1055.91	\$1062.34	\$1160.89
	30"(762mm)	28.5"(724mm)	QUS1-1630-CL	N			1169.46	1415.91	1478.03	1215.80	1223.30	1330.42
	36"(914mm)	34.5"(876mm)	QUS1-1636-CL	N			1340.06	1607.24	1674.71	1375.69	1384.26	1499.95
	42"(1067mm)	40.5"(1029mm)	QUS1-1642-CL	N			1510.66	1798.57	1871.39	1551.46	1561.10	1685.36
	48"(1219mm)	46.5"(1181mm)	QUS1-1648-CL	N			1697.14	2005.78	2083.95	1716.47	1727.18	1860.01
	54"(1372mm)	52.5"(1334mm)	QUS1-1654-CL	N			1872.86	2202.23	2285.75	1943.61	1955.39	2096.79
	60"(1524mm)	58.5"(1486mm)	QUS1-1660-CL	N			2110.71	2460.81	2549.68	2108.62	2121.47	2271.44
	66"(1676mm)	64.5"(1638mm)	QUS1-1666-CL	N			2286.43	2657.26	2751.48	2301.48	2315.40	2473.94
	72"(1829mm)	70.5"(1791mm)	QUS1-1672-CL	N			2490.00	2881.56	2981.13	1159.29	1164.65	1254.63

This page intentionally blank

Overhead Storage Unit — Hinged Doors — Wood Case

Single Sided

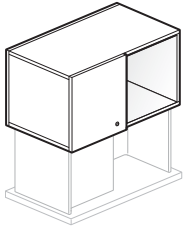

QUS1-XXXX-AXXNX
(Hinged Door left/Open Right)

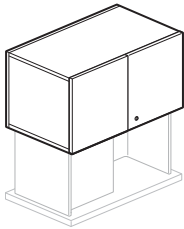

QUS1-XXXX-CXXNX
(Full Hinged Doors)

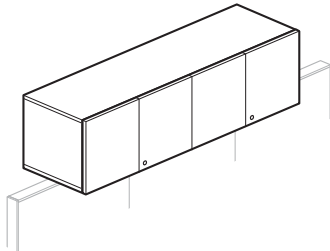

QUS1-XXXX-CXXNX
(Full Hinged Doors)

Features

- Includes overhead unit with wood case and hinged doors (steel, laminate or wood with touch latch).
- Hinged doors require field assembly.
- Locking (chrome only) and non-locking options available; refer to Lock Program Price List.

Specification Tips

- Overhead Storage Unit can be stanchion mounted on Beside Base Units or top mounted on a system panel; cannot be wall mounted.
- When designing with separately specified stanchion kits no shelves required directly under overhead.
- Maximum stacking with a base unit, a stanchion kit and an overhead unit not to exceed 58" (1473mm). Maximum stacking with a panel and an overhead storage unit not to exceed 66" (1676mm).
- Accepts separately specified lighting.
- Doors are not designed to be retrofitted.
- Separately specified if applicable:
 - Stanchion Kit (hardware included)
 - Panel attachment hardware
- Beside overhead storage unit can be off-modular mounted on separately specified Compose aluminum top trim (UZCC) and PREMISE (QNGB-0000-PZ).

Notes: Attachment hardware is application specific.

See Specification Guide.

24"-42" (610mm-1067mm) Full hinge units have two doors and one lock if specified.

48"-72" (1219mm-1829mm) Full hinge units have four doors and two locks if specified.

To Order, Specify:

1) Product number, including:

1 Door Material Option:

- S** Steel
- L** Laminate
- W** Wood

2 Lock Option:

- L** Locking, add **\$73.91** list
- N** Non-Locking

- 2) Case wood finish.
- 3) Door material front color.
- 4) Door material front edgeband color with touch latch (laminate only).

Overhead Storage Unit — Hinged Doors — Wood Case

Single Sided

Description	Outside Depth	Outside Width	Total Inside Width	Number	① ②		Case Wood Group A		Laminate Door		Wood Door		
					A	B	A	B	Group A	Group B			
Hinged Door/Open Right													
	18"(457mm)	24"(610mm)	22.5"(572mm)	QUS1-1624-AW	■	N	■	\$1262.13	\$1487.85	\$1544.62	\$1238.28	\$1244.71	\$1343.26
		30"(762mm)	28.5"(724mm)	QUS1-1630-AW	■	N	■	1351.83	1598.28	1660.40	1317.27	1324.77	1431.89
		36"(914mm)	34.5"(876mm)	QUS1-1636-AW	■	N	■	1441.53	1708.71	1776.18	1396.26	1404.83	1520.52
		42"(1067mm)	40.5"(1029mm)	QUS1-1642-AW	■	N	■	1531.23	1819.14	1891.96	1483.19	1492.83	1617.09
		48"(1219mm)	46.5"(1181mm)	QUS1-1648-AW	■	N	■	1628.87	1937.51	2015.68	1564.74	1575.45	1708.28
		54"(1372mm)	52.5"(1334mm)	QUS1-1654-AW	■	N	■	1721.13	2050.50	2134.02	1712.70	1724.48	1865.88
		60"(1524mm)	58.5"(1486mm)	QUS1-1660-AW	■	N	■	1879.80	2229.90	2318.77	1845.67	1858.52	2008.49
		66"(1676mm)	64.5"(1638mm)	QUS1-1666-AW	■	N	■	2023.48	2394.31	2488.53	1965.78	1979.70	2138.24
		72"(1829mm)	70.5"(1791mm)	QUS1-1672-AW	■	N	■	2154.30	2545.86	2645.43	1159.29	1164.65	1254.63
Hinged Door/Open Left													
	18"(457mm)	24"(610mm)	22.5"(572mm)	QUS1-1624-BW	■	N	■	\$1262.13	\$1487.85	\$1544.62	\$1238.28	\$1244.71	\$1343.26
		30"(762mm)	28.5"(724mm)	QUS1-1630-BW	■	N	■	1351.83	1598.28	1660.40	1317.27	1324.77	1431.89
		36"(914mm)	34.5"(876mm)	QUS1-1636-BW	■	N	■	1441.53	1708.71	1776.18	1396.26	1404.83	1520.52
		42"(1067mm)	40.5"(1029mm)	QUS1-1642-BW	■	N	■	1531.23	1819.14	1891.96	1483.19	1492.83	1617.09
		48"(1219mm)	46.5"(1181mm)	QUS1-1648-BW	■	N	■	1628.87	1937.51	2015.68	1564.74	1575.45	1708.28
		54"(1372mm)	52.5"(1334mm)	QUS1-1654-BW	■	N	■	1721.13	2050.50	2134.02	1712.70	1724.48	1865.88
		60"(1524mm)	58.5"(1486mm)	QUS1-1660-BW	■	N	■	1879.80	2229.90	2318.77	1845.67	1858.52	2008.49
		66"(1676mm)	64.5"(1638mm)	QUS1-1666-BW	■	N	■	2023.48	2394.31	2488.53	1965.78	1979.70	2138.24
		72"(1829mm)	70.5"(1791mm)	QUS1-1672-BW	■	N	■	2154.30	2545.86	2645.43	1224.88	1230.24	1320.22
Full Hinged Doors													
	18"(457mm)	24"(610mm)	22.5"(572mm)	QUS1-1624-CW	■	N	■	\$1327.72	\$1553.44	\$1610.21	\$1322.86	\$1329.29	\$1427.84
		30"(762mm)	28.5"(724mm)	QUS1-1630-CW	■	N	■	1436.41	1682.86	1744.98	1420.84	1428.34	1535.46
		36"(914mm)	34.5"(876mm)	QUS1-1636-CW	■	N	■	1545.10	1812.28	1879.75	1518.82	1527.39	1643.08
		42"(1067mm)	40.5"(1029mm)	QUS1-1642-CW	■	N	■	1653.79	1941.70	2014.52	1632.68	1642.32	1766.58
		48"(1219mm)	46.5"(1181mm)	QUS1-1648-CW	■	N	■	1778.36	2087.00	2165.17	1735.78	1746.49	1879.32
		54"(1372mm)	52.5"(1334mm)	QUS1-1654-CW	■	N	■	1892.17	2221.54	2305.06	1905.29	1917.07	2058.47
		60"(1524mm)	58.5"(1486mm)	QUS1-1660-CW	■	N	■	2072.39	2422.49	2511.36	2059.81	2072.66	2222.63
		66"(1676mm)	64.5"(1638mm)	QUS1-1666-CW	■	N	■	2237.62	2608.45	2702.67	2201.47	2215.39	2373.93
		72"(1829mm)	70.5"(1791mm)	QUS1-1672-CW	■	N	■	2389.99	2781.55	2881.12	1218.21	1223.57	1313.55

Overhead Storage Unit — Hinged Doors — Wood Case

Single Sided

Description	Outside Depth	Outside Width	Total Inside Width	Number	①	②	Case Wood Group B				Wood Door	
							Steel Door A	Steel Door B	Laminate Door A	Laminate Door B	Group A	Group B
Hinged Door/Open Right												
	18"(457mm)	24"(610mm)	22.5"(572mm)	QUS1-1624-AW	■	N	\$1321.05	\$1546.77	\$1603.54	\$1307.91	\$1314.34	\$1412.89
	30"(762mm)	28.5"(724mm)	28.5"(724mm)	QUS1-1630-AW	■	N	1421.46	1667.91	1730.03	1397.61	1405.11	1512.23
	36"(914mm)	34.5"(876mm)	34.5"(876mm)	QUS1-1636-AW	■	N	1521.87	1789.05	1856.52	1487.31	1495.88	1611.57
	42"(1067mm)	40.5"(1029mm)	40.5"(1029mm)	QUS1-1642-AW	■	N	1622.28	1910.19	1983.01	1584.95	1594.59	1718.85
	48"(1219mm)	46.5"(1181mm)	46.5"(1181mm)	QUS1-1648-AW	■	N	1730.63	2039.27	2117.44	1677.21	1687.92	1820.75
	54"(1372mm)	52.5"(1334mm)	52.5"(1334mm)	QUS1-1654-AW	■	N	1833.60	2162.97	2246.49	1835.88	1847.66	1989.06
	60"(1524mm)	58.5"(1486mm)	58.5"(1486mm)	QUS1-1660-AW	■	N	2002.98	2353.08	2441.95	1979.56	1992.41	2142.38
	66"(1676mm)	64.5"(1638mm)	64.5"(1638mm)	QUS1-1666-AW	■	N	2157.37	2528.20	2622.42	2110.38	2124.30	2282.84
	72"(1829mm)	70.5"(1791mm)	70.5"(1791mm)	QUS1-1672-AW	■	N	2298.90	2690.46	2790.03	1218.21	1223.57	1313.55
Hinged Door/Open Left												
	18"(457mm)	24"(610mm)	22.5"(572mm)	QUS1-1624-BW	■	N	\$1321.05	\$1546.77	\$1603.54	\$1307.91	\$1314.34	\$1412.89
	30"(762mm)	28.5"(724mm)	28.5"(724mm)	QUS1-1630-BW	■	N	1421.46	1667.91	1730.03	1397.61	1405.11	1512.23
	36"(914mm)	34.5"(876mm)	34.5"(876mm)	QUS1-1636-BW	■	N	1521.87	1789.05	1856.52	1487.31	1495.88	1611.57
	42"(1067mm)	40.5"(1029mm)	40.5"(1029mm)	QUS1-1642-BW	■	N	1622.28	1910.19	1983.01	1584.95	1594.59	1718.85
	48"(1219mm)	46.5"(1181mm)	46.5"(1181mm)	QUS1-1648-BW	■	N	1730.63	2039.27	2117.44	1677.21	1687.92	1820.75
	54"(1372mm)	52.5"(1334mm)	52.5"(1334mm)	QUS1-1654-BW	■	N	1833.60	2162.97	2246.49	1835.88	1847.66	1989.06
	60"(1524mm)	58.5"(1486mm)	58.5"(1486mm)	QUS1-1660-BW	■	N	2002.98	2353.08	2441.95	1979.56	1992.41	2142.38
	66"(1676mm)	64.5"(1638mm)	64.5"(1638mm)	QUS1-1666-BW	■	N	2157.37	2528.20	2622.42	2110.38	2124.30	2282.84
	72"(1829mm)	70.5"(1791mm)	70.5"(1791mm)	QUS1-1672-BW	■	N	2298.90	2690.46	2790.03	1283.80	1289.16	1379.14
Full Hinged Doors												
	18"(457mm)	24"(610mm)	22.5"(572mm)	QUS1-1624-CW	■	N	\$1386.64	\$1612.36	\$1669.13	\$1392.49	\$1398.92	\$1497.47
	30"(762mm)	28.5"(724mm)	28.5"(724mm)	QUS1-1630-CW	■	N	1506.04	1752.49	1814.61	1501.18	1508.68	1615.80
	36"(914mm)	34.5"(876mm)	34.5"(876mm)	QUS1-1636-CW	■	N	1625.44	1892.62	1960.09	1609.87	1618.44	1734.13
	42"(1067mm)	40.5"(1029mm)	40.5"(1029mm)	QUS1-1642-CW	■	N	1744.84	2032.75	2105.57	1734.44	1744.08	1868.34
	48"(1219mm)	46.5"(1181mm)	46.5"(1181mm)	QUS1-1648-CW	■	N	1880.12	2188.76	2266.93	1848.25	1858.96	1991.79
	54"(1372mm)	52.5"(1334mm)	52.5"(1334mm)	QUS1-1654-CW	■	N	2004.64	2334.01	2417.53	2028.47	2040.25	2181.65
	60"(1524mm)	58.5"(1486mm)	58.5"(1486mm)	QUS1-1660-CW	■	N	2195.57	2545.67	2634.54	2193.70	2206.55	2356.52
	66"(1676mm)	64.5"(1638mm)	64.5"(1638mm)	QUS1-1666-CW	■	N	2371.51	2742.34	2836.56	2346.07	2359.99	2518.53
	72"(1829mm)	70.5"(1791mm)	70.5"(1791mm)	QUS1-1672-CW	■	N	2534.59	2926.15	3025.72	994.09	1000.52	1099.07

This page intentionally blank

Overhead Storage Unit — Sliding Doors — Laminate Case

Single Sided

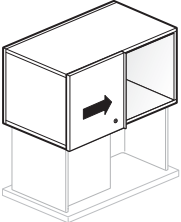

QUS1-XXXX-EXXVX
(When in the locked position, door is on left side of unit)

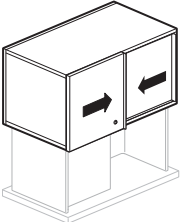

QUS1-XXXX-GXXVX
(Proud side door is in the left position - stanchion mounted)

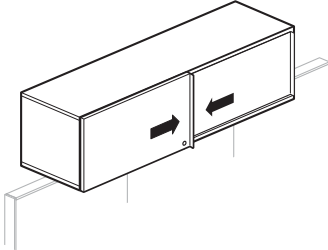

QUS1-XXXX-GXXVX
(Proud side door is in the left position - panel mounted)

Features

- Includes overhead unit with laminate case and sliding door (steel, laminate or wood).
- Sliding doors require field assembly.
- Locking (chrome only) and non-locking options available; refer to Lock Program Price List.

Specification Tips

- Overhead Storage Unit can be stanchion mounted on Beside Base Units or top mounted on a system panel; cannot be wall mounted.
- When designing with separately specified stanchion kits no shelves required directly under overhead.
- Maximum stacking with a base unit, a stanchion kit and an overhead unit not to exceed 58”(1473mm). Maximum stacking with a panel and an overhead storage unit not of exceed 66”(1676mm).
- Accepts separately specified lighting.
- Doors are not designed to be retrofitted.
- Separately specified if applicable:
 - Stanchion Kit (hardware included)
 - Panel attachment hardware
- Beside overhead storage unit can be off-modular mounted on separately specified Compose aluminum top trim (UZCC) and PREMISE (QNGB-0000-PZ).

Note: Attachment hardware is application specific. See Specification Guide.

To Order, Specify:

1) Product number, including:

1 Door Material Option:

- S** Steel
- L** Laminate
- W** Wood

2 Lock Option:

- L** Locking, add **\$73.91** list
- N** Non-Locking

- 2) Case laminate color.
- 3) Case edgeband trim color.
- 4) Door material front color.
- 5) Door material front edgeband color (laminate only).
- 6) Pull trim color.

Overhead Storage Unit — Sliding Doors — Laminate Case

Single Sided

Description	Outside Depth	Outside Width	Total Inside Width	Number	① ②	Case Laminate A		Laminate Door		Wood Door	
						Steel Door A	B	A	B	Group A	Group B
Sliding Door/Right											
18"(457mm)	30"(762mm)	28.5"(724mm)	QUS1-1630-DL	V		\$1107.64	\$1347.96	\$1410.08	\$1066.20	\$1073.70	\$1180.82
	36"(914mm)	34.5"(876mm)	QUS1-1636-DL	V		1190.46	1451.51	1518.98	1138.31	1146.88	1262.57
	42"(1067mm)	40.5"(1029mm)	QUS1-1642-DL	V		1273.28	1555.06	1627.88	1210.42	1220.06	1344.32
	48"(1219mm)	46.5"(1181mm)	QUS1-1648-DL	V		1356.10	1658.61	1736.78	1282.53	1293.24	1426.07
	54"(1372mm)	52.5"(1334mm)	QUS1-1654-DL	V		1438.92	1762.16	1845.68	1416.77	1428.55	1569.95
	60"(1524mm)	58.5"(1486mm)	QUS1-1660-DL	V		1583.87	1927.84	2016.71	1488.88	1501.73	1651.70
	66"(1676mm)	64.5"(1638mm)	QUS1-1666-DL	V		1666.69	2031.39	2125.61	1588.84	1602.76	1761.30
	72"(1829mm)	70.5"(1791mm)	QUS1-1672-DL	V		1777.36	2162.79	2262.36	994.09	1000.52	1099.07
Sliding Door/Left											
18"(457mm)	30"(762mm)	28.5"(724mm)	QUS1-1630-EL	V		\$1107.64	\$1347.96	\$1410.08	\$1066.20	\$1073.70	\$1180.82
	36"(914mm)	34.5"(876mm)	QUS1-1636-EL	V		1190.46	1451.51	1518.98	1138.31	1146.88	1262.57
	42"(1067mm)	40.5"(1029mm)	QUS1-1642-EL	V		1273.28	1555.06	1627.88	1210.42	1220.06	1344.32
	48"(1219mm)	46.5"(1181mm)	QUS1-1648-EL	V		1356.10	1658.61	1736.78	1282.53	1293.24	1426.07
	54"(1372mm)	52.5"(1334mm)	QUS1-1654-EL	V		1438.92	1762.16	1845.68	1416.77	1428.55	1569.95
	60"(1524mm)	58.5"(1486mm)	QUS1-1660-EL	V		1583.87	1927.84	2016.71	1488.88	1501.73	1651.70
	66"(1676mm)	64.5"(1638mm)	QUS1-1666-EL	V		1666.69	2031.39	2125.61	1588.84	1602.76	1761.30
	72"(1829mm)	70.5"(1791mm)	QUS1-1672-EL	V		1777.36	2162.79	2262.36	1091.32	1097.75	1196.30
Double Sliding Door/Right											
18"(457mm)	30"(762mm)	28.5"(724mm)	QUS1-1630-FL	V		\$1204.87	\$1445.19	\$1507.31	\$1182.42	\$1189.92	\$1297.04
	36"(914mm)	34.5"(876mm)	QUS1-1636-FL	V		1306.68	1567.73	1635.20	1273.52	1282.09	1397.78
	42"(1067mm)	40.5"(1029mm)	QUS1-1642-FL	V		1408.49	1690.27	1763.09	1364.62	1374.26	1498.52
	48"(1219mm)	46.5"(1181mm)	QUS1-1648-FL	V		1510.30	1812.81	1890.98	1455.72	1466.43	1599.26
	54"(1372mm)	52.5"(1334mm)	QUS1-1654-FL	V		1612.11	1935.35	2018.87	1608.95	1620.73	1762.13
	60"(1524mm)	58.5"(1486mm)	QUS1-1660-FL	V		1776.05	2120.02	2208.89	1700.05	1712.90	1862.87
	66"(1676mm)	64.5"(1638mm)	QUS1-1666-FL	V		1877.86	2242.56	2336.78	1819.00	1832.92	1991.46
	72"(1829mm)	70.5"(1791mm)	QUS1-1672-FL	V		2007.52	2392.95	2492.52	1091.32	1097.75	1196.30
Double Sliding Door/Left											
18"(457mm)	30"(762mm)	28.5"(724mm)	QUS1-1630-GL	V		\$1204.87	\$1445.19	\$1507.31	\$1182.42	\$1189.92	\$1297.04
	36"(914mm)	34.5"(876mm)	QUS1-1636-GL	V		1306.68	1567.73	1635.20	1273.52	1282.09	1397.78
	42"(1067mm)	40.5"(1029mm)	QUS1-1642-GL	V		1408.49	1690.27	1763.09	1364.62	1374.26	1498.52
	48"(1219mm)	46.5"(1181mm)	QUS1-1648-GL	V		1510.30	1812.81	1890.98	1455.72	1466.43	1599.26
	54"(1372mm)	52.5"(1334mm)	QUS1-1654-GL	V		1612.11	1935.35	2018.87	1608.95	1620.73	1762.13
	60"(1524mm)	58.5"(1486mm)	QUS1-1660-GL	V		1776.05	2120.02	2208.89	1700.05	1712.90	1862.87
	66"(1676mm)	64.5"(1638mm)	QUS1-1666-GL	V		1877.86	2242.56	2336.78	1819.00	1832.92	1991.46
	72"(1829mm)	70.5"(1791mm)	QUS1-1672-GL	V		2007.52	2392.95	2492.52	1114.91	1121.34	1219.89

Overhead Storage Unit — Sliding Doors — Laminate Case

Single Sided

Description	Outside Depth	Outside Width	Total Inside Width	Number	①	②	Case Laminate B		Laminate Door		Wood Door	
							Steel Door A	B	A	B	Group A	Group B
Sliding Door/Right												
	18"(457mm)	30"(762mm)	28.5"(724mm)	QUS1-1630-DL	V		\$1228.46	\$1468.78	\$1530.90	\$1270.35	\$1277.85	\$1384.97
	36"(914mm)	34.5"(876mm)	34.5"(876mm)	QUS1-1636-DL	V		1394.61	1655.66	1723.13	1425.79	1434.36	1550.05
	42"(1067mm)	40.5"(1029mm)	40.5"(1029mm)	QUS1-1642-DL	V		1560.76	1842.54	1915.36	1581.23	1590.87	1715.13
	48"(1219mm)	46.5"(1181mm)	46.5"(1181mm)	QUS1-1648-DL	V		1726.91	2029.42	2107.59	1736.67	1747.38	1880.21
	54"(1372mm)	52.5"(1334mm)	52.5"(1334mm)	QUS1-1654-DL	V		1893.06	2216.30	2299.82	1954.24	1966.02	2107.42
	60"(1524mm)	58.5"(1486mm)	58.5"(1486mm)	QUS1-1660-DL	V		2121.34	2465.31	2554.18	2109.68	2122.53	2272.50
	66"(1676mm)	64.5"(1638mm)	64.5"(1638mm)	QUS1-1666-DL	V		2287.49	2652.19	2746.41	2292.97	2306.89	2465.43
	72"(1829mm)	70.5"(1791mm)	70.5"(1791mm)	QUS1-1672-DL	V		2481.49	2866.92	2966.49	1114.91	1121.34	1219.89
Sliding Door/Left												
	18"(457mm)	30"(762mm)	28.5"(724mm)	QUS1-1630-EL	V		\$1228.46	\$1468.78	\$1530.90	\$1270.35	\$1277.85	\$1384.97
	36"(914mm)	34.5"(876mm)	34.5"(876mm)	QUS1-1636-EL	V		1394.61	1655.66	1723.13	1425.79	1434.36	1550.05
	42"(1067mm)	40.5"(1029mm)	40.5"(1029mm)	QUS1-1642-EL	V		1560.76	1842.54	1915.36	1581.23	1590.87	1715.13
	48"(1219mm)	46.5"(1181mm)	46.5"(1181mm)	QUS1-1648-EL	V		1726.91	2029.42	2107.59	1736.67	1747.38	1880.21
	54"(1372mm)	52.5"(1334mm)	52.5"(1334mm)	QUS1-1654-EL	V		1893.06	2216.30	2299.82	1954.24	1966.02	2107.42
	60"(1524mm)	58.5"(1486mm)	58.5"(1486mm)	QUS1-1660-EL	V		2121.34	2465.31	2554.18	2109.68	2122.53	2272.50
	66"(1676mm)	64.5"(1638mm)	64.5"(1638mm)	QUS1-1666-EL	V		2287.49	2652.19	2746.41	2292.97	2306.89	2465.43
	72"(1829mm)	70.5"(1791mm)	70.5"(1791mm)	QUS1-1672-EL	V		2481.49	2866.92	2966.49	1212.14	1218.57	1317.12
Double Sliding Door/Right												
	18"(457mm)	30"(762mm)	28.5"(724mm)	QUS1-1630-FL	V		\$1325.69	\$1566.01	\$1628.13	\$1386.57	\$1394.07	\$1501.19
	36"(914mm)	34.5"(876mm)	34.5"(876mm)	QUS1-1636-FL	V		1510.83	1771.88	1839.35	1561.00	1569.57	1685.26
	42"(1067mm)	40.5"(1029mm)	40.5"(1029mm)	QUS1-1642-FL	V		1695.97	1977.75	2050.57	1735.43	1745.07	1869.33
	48"(1219mm)	46.5"(1181mm)	46.5"(1181mm)	QUS1-1648-FL	V		1881.11	2183.62	2261.79	1909.86	1920.57	2053.40
	54"(1372mm)	52.5"(1334mm)	52.5"(1334mm)	QUS1-1654-FL	V		2066.25	2389.49	2473.01	2146.42	2158.20	2299.60
	60"(1524mm)	58.5"(1486mm)	58.5"(1486mm)	QUS1-1660-FL	V		2313.52	2657.49	2746.36	2320.85	2333.70	2483.67
	66"(1676mm)	64.5"(1638mm)	64.5"(1638mm)	QUS1-1666-FL	V		2498.66	2863.36	2957.58	2523.13	2537.05	2695.59
	72"(1829mm)	70.5"(1791mm)	70.5"(1791mm)	QUS1-1672-FL	V		2711.65	3097.08	3196.65	1212.14	1218.57	1317.12
Double Sliding Door/Left												
	18"(457mm)	30"(762mm)	28.5"(724mm)	QUS1-1630-GL	V		\$1325.69	\$1566.01	\$1628.13	\$1386.57	\$1394.07	\$1501.19
	36"(914mm)	34.5"(876mm)	34.5"(876mm)	QUS1-1636-GL	V		1510.83	1771.88	1839.35	1561.00	1569.57	1685.26
	42"(1067mm)	40.5"(1029mm)	40.5"(1029mm)	QUS1-1642-GL	V		1695.97	1977.75	2050.57	1735.43	1745.07	1869.33
	48"(1219mm)	46.5"(1181mm)	46.5"(1181mm)	QUS1-1648-GL	V		1881.11	2183.62	2261.79	1909.86	1920.57	2053.40
	54"(1372mm)	52.5"(1334mm)	52.5"(1334mm)	QUS1-1654-GL	V		2066.25	2389.49	2473.01	2146.42	2158.20	2299.60
	60"(1524mm)	58.5"(1486mm)	58.5"(1486mm)	QUS1-1660-GL	V		2313.52	2657.49	2746.36	2320.85	2333.70	2483.67
	66"(1676mm)	64.5"(1638mm)	64.5"(1638mm)	QUS1-1666-GL	V		2498.66	2863.36	2957.58	2523.13	2537.05	2695.59
	72"(1829mm)	70.5"(1791mm)	70.5"(1791mm)	QUS1-1672-GL	V		2711.65	3097.08	3196.65	1381.86	1388.29	1486.84

This page intentionally blank

Overhead Storage Unit — Sliding Doors — Wood Case

Single Sided

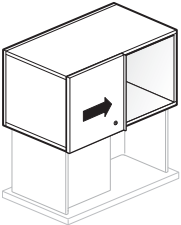

QUS1-XXXX-EXXVX
(When in the locked position, door is on left side of unit)

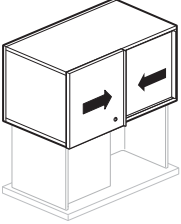

QUS1-XXXX-GXXVX
(Proud side door is in the left position - stanchion mounted)

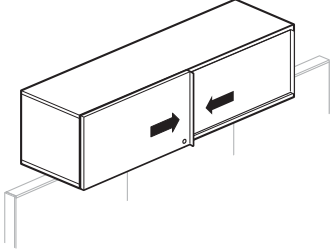

QUS1-XXXX-GXXVX
(Proud side door is in the left position - panel mounted)

Features

- Includes overhead unit with wood case and sliding door (steel, laminate or wood).
- Sliding doors require field assembly.
- Locking (chrome only) and non-locking options available; refer to Lock Program Price List.

Specification Tips

- Overhead Storage Unit can be stanchion mounted on Beside Base Units or top mounted on a system panel; cannot be wall mounted.
- When designing with separately specified stanchion kit no shelves required directly under overhead.
- Maximum stacking with a base unit, a stanchion kit and an overhead unit not to exceed 58”(1473mm). Maximum stacking with a panel and an overhead storage unit not to exceed 66”(1676mm).
- Accepts separately specified lighting.
- Doors are not designed to be retrofitted.
- Separately specified if applicable:
 - Stanchion Kit (hardware included)
 - Panel attachment hardware
- Beside overhead storage unit can be off-modular mounted on separately specified Compose aluminum top trim (UZCC) and PREMISE (QNGB-0000-PZ).

Note: Attachment hardware is application specific. See Specification Guide.

To Order, Specify:

1) Product number, including:

1 Door Material Option:

- S** Steel
- L** Laminate
- W** Wood

2 Lock Option:

- L** Locking, add **\$73.91** list
- N** Non-Locking

- 2) Case wood color.
- 3) Door material front color.
- 4) Door material front edgeband color with touch latch (laminate only).
- 5) Pull trim color.

Overhead Storage Unit — Sliding Doors — Wood Case

Single Sided

Description	Outside Depth	Outside Width	Total Inside Width	Number	①	②	Case Wood Group A				Wood Door Group A	Wood Door Group B
							Steel Door A	Steel Door B	Laminate Door A	Laminate Door B		
Sliding Door/Right												
18"(457mm)	30"(762mm)	28.5"(724mm)	QUS1-1630-DW	■	V	■	\$1495.41	\$1735.73	\$1797.85	\$1475.39	\$1482.89	\$1590.01
	36"(914mm)	34.5"(876mm)	QUS1-1636-DW	■	V	■	1599.65	1860.70	1928.17	1568.92	1577.49	1693.18
	42"(1067mm)	40.5"(1029mm)	QUS1-1642-DW	■	V	■	1703.89	1985.67	2058.49	1662.45	1672.09	1796.35
	48"(1219mm)	46.5"(1181mm)	QUS1-1648-DW	■	V	■	1808.13	2110.64	2188.81	1755.98	1766.69	1899.52
	54"(1372mm)	52.5"(1334mm)	QUS1-1654-DW	■	V	■	1912.37	2235.61	2319.13	1915.92	1927.70	2069.10
	60"(1524mm)	58.5"(1486mm)	QUS1-1660-DW	■	V	■	2083.02	2426.99	2515.86	2060.87	2073.72	2223.69
	66"(1676mm)	64.5"(1638mm)	QUS1-1666-DW	■	V	■	2238.68	2603.38	2697.60	2192.96	2206.88	2365.42
	72"(1829mm)	70.5"(1791mm)	QUS1-1672-DW	■	V	■	2381.48	2766.91	2866.48	1381.86	1388.29	1486.84
Sliding Door/Left												
18"(457mm)	30"(762mm)	28.5"(724mm)	QUS1-1630-EW	■	V	■	\$1495.41	\$1735.73	\$1797.85	\$1475.39	\$1482.89	\$1590.01
	36"(914mm)	34.5"(876mm)	QUS1-1636-EW	■	V	■	1599.65	1860.70	1928.17	1568.92	1577.49	1693.18
	42"(1067mm)	40.5"(1029mm)	QUS1-1642-EW	■	V	■	1703.89	1985.67	2058.49	1662.45	1672.09	1796.35
	48"(1219mm)	46.5"(1181mm)	QUS1-1648-EW	■	V	■	1808.13	2110.64	2188.81	1755.98	1766.69	1899.52
	54"(1372mm)	52.5"(1334mm)	QUS1-1654-EW	■	V	■	1912.37	2235.61	2319.13	1915.92	1927.70	2069.10
	60"(1524mm)	58.5"(1486mm)	QUS1-1660-EW	■	V	■	2083.02	2426.99	2515.86	2060.87	2073.72	2223.69
	66"(1676mm)	64.5"(1638mm)	QUS1-1666-EW	■	V	■	2238.68	2603.38	2697.60	2192.96	2206.88	2365.42
	72"(1829mm)	70.5"(1791mm)	QUS1-1672-EW	■	V	■	2381.48	2766.91	2866.48	1479.09	1485.52	1584.07
Double Sliding Door/Right												
18"(457mm)	30"(762mm)	28.5"(724mm)	QUS1-1630-FW	■	V	■	\$1592.64	\$1832.96	\$1895.08	\$1591.61	\$1599.11	\$1706.23
	36"(914mm)	34.5"(876mm)	QUS1-1636-FW	■	V	■	1715.87	1976.92	2044.39	1704.13	1712.70	1828.39
	42"(1067mm)	40.5"(1029mm)	QUS1-1642-FW	■	V	■	1839.10	2120.88	2193.70	1816.65	1826.29	1950.55
	48"(1219mm)	46.5"(1181mm)	QUS1-1648-FW	■	V	■	1962.33	2264.84	2343.01	1929.17	1939.88	2072.71
	54"(1372mm)	52.5"(1334mm)	QUS1-1654-FW	■	V	■	2085.56	2408.80	2492.32	2108.10	2119.88	2261.28
	60"(1524mm)	58.5"(1486mm)	QUS1-1660-FW	■	V	■	2275.20	2619.17	2708.04	2272.04	2284.89	2434.86
	66"(1676mm)	64.5"(1638mm)	QUS1-1666-FW	■	V	■	2449.85	2814.55	2908.77	2423.12	2437.04	2595.58
	72"(1829mm)	70.5"(1791mm)	QUS1-1672-FW	■	V	■	2611.64	2997.07	3096.64	1479.09	1485.52	1584.07
Double Sliding Door/Left												
18"(457mm)	30"(762mm)	28.5"(724mm)	QUS1-1630-GW	■	V	■	\$1592.64	\$1832.96	\$1895.08	\$1591.61	\$1599.11	\$1706.23
	36"(914mm)	34.5"(876mm)	QUS1-1636-GW	■	V	■	1715.87	1976.92	2044.39	1704.13	1712.70	1828.39
	42"(1067mm)	40.5"(1029mm)	QUS1-1642-GW	■	V	■	1839.10	2120.88	2193.70	1816.65	1826.29	1950.55
	48"(1219mm)	46.5"(1181mm)	QUS1-1648-GW	■	V	■	1962.33	2264.84	2343.01	1929.17	1939.88	2072.71
	54"(1372mm)	52.5"(1334mm)	QUS1-1654-GW	■	V	■	2085.56	2408.80	2492.32	2108.10	2119.88	2261.28
	60"(1524mm)	58.5"(1486mm)	QUS1-1660-GW	■	V	■	2275.20	2619.17	2708.04	2272.04	2284.89	2434.86
	66"(1676mm)	64.5"(1638mm)	QUS1-1666-GW	■	V	■	2449.85	2814.55	2908.77	2423.12	2437.04	2595.58
	72"(1829mm)	70.5"(1791mm)	QUS1-1672-GW	■	V	■	2611.64	2997.07	3096.64	1451.49	1457.92	1556.47

Overhead Storage Unit — Sliding Doors — Wood Case

Single Sided

Description	Outside Depth	Outside Width	Total Inside Width	Number	①	②	Case Wood Group B				Wood Door Group A	Wood Door Group B
							Steel Door A	Steel Door B	Laminate Door A	Laminate Door B		
Sliding Door/Right												
18"(457mm)	30"(762mm)	28.5"(724mm)	QUS1-1630-DW	■	V	■	\$1565.04	\$1805.36	\$1867.48	\$1555.73	\$1563.23	\$1670.35
	36"(914mm)	34.5"(876mm)	QUS1-1636-DW	■	V	■	1679.99	1941.04	2008.51	1659.97	1668.54	1784.23
	42"(1067mm)	40.5"(1029mm)	QUS1-1642-DW	■	V	■	1794.94	2076.72	2149.54	1764.21	1773.85	1898.11
	48"(1219mm)	46.5"(1181mm)	QUS1-1648-DW	■	V	■	1909.89	2212.40	2290.57	1868.45	1879.16	2011.99
	54"(1372mm)	52.5"(1334mm)	QUS1-1654-DW	■	V	■	2024.84	2348.08	2431.60	2039.10	2050.88	2192.28
	60"(1524mm)	58.5"(1486mm)	QUS1-1660-DW	■	V	■	2206.20	2550.17	2639.04	2194.76	2207.61	2357.58
	66"(1676mm)	64.5"(1638mm)	QUS1-1666-DW	■	V	■	2372.57	2737.27	2831.49	2337.56	2351.48	2510.02
	72"(1829mm)	70.5"(1791mm)	QUS1-1672-DW	■	V	■	2526.08	2911.51	3011.08	1451.49	1457.92	1556.47
Sliding Door/Left												
18"(457mm)	30"(762mm)	28.5"(724mm)	QUS1-1630-EW	■	V	■	\$1565.04	\$1805.36	\$1867.48	\$1555.73	\$1563.23	\$1670.35
	36"(914mm)	34.5"(876mm)	QUS1-1636-EW	■	V	■	1679.99	1941.04	2008.51	1659.97	1668.54	1784.23
	42"(1067mm)	40.5"(1029mm)	QUS1-1642-EW	■	V	■	1794.94	2076.72	2149.54	1764.21	1773.85	1898.11
	48"(1219mm)	46.5"(1181mm)	QUS1-1648-EW	■	V	■	1909.89	2212.40	2290.57	1868.45	1879.16	2011.99
	54"(1372mm)	52.5"(1334mm)	QUS1-1654-EW	■	V	■	2024.84	2348.08	2431.60	2039.10	2050.88	2192.28
	60"(1524mm)	58.5"(1486mm)	QUS1-1660-EW	■	V	■	2206.20	2550.17	2639.04	2194.76	2207.61	2357.58
	66"(1676mm)	64.5"(1638mm)	QUS1-1666-EW	■	V	■	2372.57	2737.27	2831.49	2337.56	2351.48	2510.02
	72"(1829mm)	70.5"(1791mm)	QUS1-1672-EW	■	V	■	2526.08	2911.51	3011.08	1548.72	1555.15	1653.70
Double Sliding Door/Right												
18"(457mm)	30"(762mm)	28.5"(724mm)	QUS1-1630-FW	■	V	■	\$1662.27	\$1902.59	\$1964.71	\$1671.95	\$1679.45	\$1786.57
	36"(914mm)	34.5"(876mm)	QUS1-1636-FW	■	V	■	1796.21	2057.26	2124.73	1795.18	1803.75	1919.44
	42"(1067mm)	40.5"(1029mm)	QUS1-1642-FW	■	V	■	1930.15	2211.93	2284.75	1918.41	1928.05	2052.31
	48"(1219mm)	46.5"(1181mm)	QUS1-1648-FW	■	V	■	2064.09	2366.60	2444.77	2041.64	2052.35	2185.18
	54"(1372mm)	52.5"(1334mm)	QUS1-1654-FW	■	V	■	2198.03	2521.27	2604.79	2231.28	2243.06	2384.46
	60"(1524mm)	58.5"(1486mm)	QUS1-1660-FW	■	V	■	2398.38	2742.35	2831.22	2405.93	2418.78	2568.75
	66"(1676mm)	64.5"(1638mm)	QUS1-1666-FW	■	V	■	2583.74	2948.44	3042.66	2567.72	2581.64	2740.18
	72"(1829mm)	70.5"(1791mm)	QUS1-1672-FW	■	V	■	2756.24	3141.67	3241.24	1548.72	1555.15	1653.70
Double Sliding Door/Left												
18"(457mm)	30"(762mm)	28.5"(724mm)	QUS1-1630-GW	■	V	■	\$1662.27	\$1902.59	\$1964.71	\$1671.95	\$1679.45	\$1786.57
	36"(914mm)	34.5"(876mm)	QUS1-1636-GW	■	V	■	1796.21	2057.26	2124.73	1795.18	1803.75	1919.44
	42"(1067mm)	40.5"(1029mm)	QUS1-1642-GW	■	V	■	1930.15	2211.93	2284.75	1918.41	1928.05	2052.31
	48"(1219mm)	46.5"(1181mm)	QUS1-1648-GW	■	V	■	2064.09	2366.60	2444.77	2041.64	2052.35	2185.18
	54"(1372mm)	52.5"(1334mm)	QUS1-1654-GW	■	V	■	2198.03	2521.27	2604.79	2231.28	2243.06	2384.46
	60"(1524mm)	58.5"(1486mm)	QUS1-1660-GW	■	V	■	2398.38	2742.35	2831.22	2405.93	2418.78	2568.75
	66"(1676mm)	64.5"(1638mm)	QUS1-1666-GW	■	V	■	2583.74	2948.44	3042.66	2567.72	2581.64	2740.18
	72"(1829mm)	70.5"(1791mm)	QUS1-1672-GW	■	V	■	2756.24	3141.67	3241.24	1167.34	1538.15	1779.05

Overhead Storage Unit — Open

Dual Sided

Description	Outside Depth	Outside Width	Total Inside Width	Number ①	Laminate		Wood Group A	Wood Group B
					A	B		
Open Right								
	18"(457mm)	48"(1219mm)	46.5"(1181mm)	QUS2-1648-J ■ NNN	\$1880.81	\$1264.50	\$1718.64	\$1897.63
		54"(1372mm)	52.5"(1334mm)	QUS2-1654-J ■ NNN	2010.10	1423.79	1961.26	2082.62
		60"(1524mm)	58.5"(1486mm)	QUS2-1660-J ■ NNN	2205.80	1520.95	2141.75	2252.62
		66"(1676mm)	64.5"(1638mm)	QUS2-1666-J ■ NNN	2386.51	1645.96	2350.09	2409.76
		72"(1829mm)	70.5"(1791mm)	QUS2-1672-J ■ NNN	2554.36	1167.34	1627.70	1811.54
Open Left								
	18"(457mm)	48"(1219mm)	46.5"(1181mm)	QUS2-1648-K ■ NNN	\$1880.81	\$1264.50	\$1718.64	\$1897.63
		54"(1372mm)	52.5"(1334mm)	QUS2-1654-K ■ NNN	2010.10	1423.79	1961.26	2082.62
		60"(1524mm)	58.5"(1486mm)	QUS2-1660-K ■ NNN	2205.80	1520.95	2141.75	2252.62
		66"(1676mm)	64.5"(1638mm)	QUS2-1666-K ■ NNN	2386.51	1645.96	2350.09	2409.76
		72"(1829mm)	70.5"(1791mm)	QUS2-1672-K ■ NNN	2554.36	1618.06	1627.70	1811.54

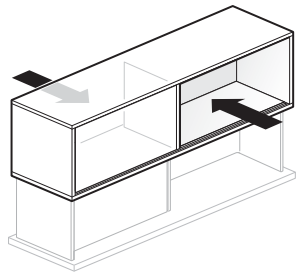

QUS2-XXXX-JXNNN
(Open right)

Features

- Includes one dual sided open overhead with laminate or wood case and an opening on each side.

Specification Tips

- Overhead Storage Unit can be stanchion mounted on Beside Base Units or top mounted on a system panel; cannot be wall mounted.
- When designing with separately specified stanchion kits no shelves required directly under overhead.
- Maximum stacking with a base unit, a stanchion kit and an overhead unit not to exceed 58"(1473mm). Maximum stacking with a panel and an overhead storage unit not of exceed 66"(1676mm).
- Accepts separately specified lighting.
- Doors are not designed to be retrofitted.
- Separately specified if applicable:
 - Stanchion Kit (hardware included)
 - Panel attachment hardware
- Beside overhead storage unit can be off-modular mounted on separately specified Compose aluminum top trim (UZCC) and PREMISE (QNGB-0000-PZ).
- Designed to be used with shared back-to-back office applications.

Note: Attachment hardware is application specific.
See Specification Guide.

To Order, Specify:

- 1) Product number, including:

① Case Surface Option:

- L Laminate
- W Wood

- 2) Laminate or wood finish color.
- 3) Edgeband trim color.

This page intentionally blank

Overhead Storage Unit — Sliding Doors — Laminate Case

Dual Sided

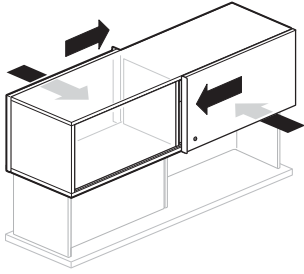

QUS2-XXXX-DXXVX
(When in a locked position,
the door is on the right side of the unit)

Features

- Includes overhead unit with laminate case and dual sliding doors (laminate, wood or steel).
- Doors are field assembled.
- Locking (chrome only) and non-locking options available; refer to Lock Program Price List.

Specification Tips

- Overhead Storage Unit can be stanchion mounted on Beside Base Units or top mounted on a system panel; cannot be wall mounted.
- When designing with separately specified stanchion kits no shelves required directly under overhead.
- Maximum stacking with a base unit, a stanchion kit and an overhead unit not to exceed 58"(1473mm). Maximum stacking with a panel and an overhead storage unit not to exceed 66"(1676mm).
- Accepts separately specified lighting.
- Doors are not designed to be retrofitted.
- Separately specified if applicable:
 - Stanchion Kit (hardware included)
 - Panel attachment hardware
- Beside overhead storage unit can be off-modular mounted on separately specified Compose aluminum top trim (UZCC) and PREMISE (QNGB-0000-PZ).
- Designed to be used with shared back-to-back office applications.

Note: Attachment hardware is application specific.
See Specification Guide.

To Order, Specify:

1) Product number, including:

① Door Material Option:

- L** Laminate
- W** Wood
- S** Steel

② Lock Option:

- L** Locking, add **\$73.91** list
- N** Non-Locking

- 2) Case laminate finish color.
- 3) Case edgeband trim color.
- 4) Door material front color.
- 5) Door material front edgeband (laminate only).
- 6) Pull trim color.*

***Note: \$5.36** upcharge for Metallic and accent Pull trim colors

Overhead Storage Unit — Sliding Doors — Laminate Case

Dual Sided

Description	Outside Depth	Outside Width	Total Inside Width	Number	①	②	Case Laminate A		Laminate Door		Wood Door	
							Steel Door A	B	A	B	Group A	Group B
Sliding Door/Right												
	18"(457mm)	48"(1219mm)	46.5"(1181mm)	QUS2-1648-DL	■	V ■	\$1823.32	\$2252.37	\$2330.54	\$1785.96	\$1796.67	\$1989.08
		54"(1372mm)	52.5"(1334mm)	QUS2-1654-DL	■	V ■	2001.93	2451.71	2535.23	2015.99	2027.77	2228.75
		60"(1524mm)	58.5"(1486mm)	QUS2-1660-DL	■	V ■	2242.67	2713.18	2802.05	2183.89	2196.74	2406.29
		66"(1676mm)	64.5"(1638mm)	QUS2-1666-DL	■	V ■	2421.28	2912.52	3006.74	2379.64	2393.56	2611.68
		72"(1829mm)	70.5"(1791mm)	QUS2-1672-DL	■	V ■	2627.74	3139.71	3239.28	1618.06	1627.70	1811.54
Sliding Door/Left												
	18"(457mm)	48"(1219mm)	46.5"(1181mm)	QUS2-1648-EL	■	V ■	\$1823.32	\$2252.37	\$2330.54	\$1785.96	\$1796.67	\$1989.08
		54"(1372mm)	52.5"(1334mm)	QUS2-1654-EL	■	V ■	2001.93	2451.71	2535.23	2015.99	2027.77	2228.75
		60"(1524mm)	58.5"(1486mm)	QUS2-1660-EL	■	V ■	2242.67	2713.18	2802.05	2183.89	2196.74	2406.29
		66"(1676mm)	64.5"(1638mm)	QUS2-1666-EL	■	V ■	2421.28	2912.52	3006.74	2379.64	2393.56	2611.68
		72"(1829mm)	70.5"(1791mm)	QUS2-1672-EL	■	V ■	2627.74	3139.71	3239.28	1988.87	1998.51	2182.35

Description	Outside Depth	Outside Width	Total Inside Width	Number	①	②	Case Laminate B		Laminate Door		Wood Door	
							Steel Door A	B	A	B	Group A	Group B
Sliding Door/Right												
	18"(457mm)	48"(1219mm)	46.5"(1181mm)	QUS2-1648-DL	■	V ■	\$2194.13	\$2623.18	\$2701.35	\$2240.10	\$2250.81	\$2443.22
		54"(1372mm)	52.5"(1334mm)	QUS2-1654-DL	■	V ■	2456.07	2905.85	2989.37	2553.46	2565.24	2766.22
		60"(1524mm)	58.5"(1486mm)	QUS2-1660-DL	■	V ■	2780.14	3250.65	3339.52	2804.69	2817.54	3027.09
		66"(1676mm)	64.5"(1638mm)	QUS2-1666-DL	■	V ■	3042.08	3533.32	3627.54	3083.77	3097.69	3315.81
		72"(1829mm)	70.5"(1791mm)	QUS2-1672-DL	■	V ■	3331.87	3843.84	3943.41	1988.87	1998.51	2182.35
Sliding Door/Left												
	18"(457mm)	48"(1219mm)	46.5"(1181mm)	QUS2-1648-EL	■	V ■	\$2194.13	\$2623.18	\$2701.35	\$2240.10	\$2250.81	\$2443.22
		54"(1372mm)	52.5"(1334mm)	QUS2-1654-EL	■	V ■	2456.07	2905.85	2989.37	2553.46	2565.24	2766.22
		60"(1524mm)	58.5"(1486mm)	QUS2-1660-EL	■	V ■	2780.14	3250.65	3339.52	2804.69	2817.54	3027.09
		66"(1676mm)	64.5"(1638mm)	QUS2-1666-EL	■	V ■	3042.08	3533.32	3627.54	3083.77	3097.69	3315.81
		72"(1829mm)	70.5"(1791mm)	QUS2-1672-EL	■	V ■	3331.87	3843.84	3943.41	2258.05	2267.69	2451.53

Overhead Storage Unit — Sliding Doors — Wood Case

Dual Sided

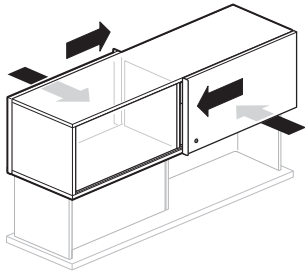

QUS2-XXXX-DXXVX
(When in a locked position,
the door is on the right side of the unit)

Features

- Includes overhead unit with wood case and dual sliding doors (laminate, wood or steel).
- Doors are field assembled.
- Locking (chrome only) and non-locking options available; refer to Lock Program Price List.

Specification Tips

- Overhead Storage Unit can be stanchion mounted on Beside Base Units or top mounted on a system panel; cannot be wall mounted.
- When designing with separately specified stanchion kits no shelves required directly under overhead.
- Maximum stacking with a base unit, a stanchion kit and an overhead unit not to exceed 58"(1473mm). Maximum stacking with a panel and an overhead storage unit not to exceed 66"(1676mm).
- Accepts separately specified lighting.
- Doors are not designed to be retrofitted.
- Separately specified if applicable:
 - Stanchion Kit (hardware included)
 - Panel attachment hardware
- Beside overhead storage unit can be off-modular mounted on separately specified Compose aluminum top trim (UZCC) and PREMISE (QNGB-0000-PZ).
- Designed to be used with shared back-to-back office applications.

Note: Attachment hardware is application specific.
See Specification Guide.

To Order, Specify:

1) Product number, including:

① Door Material Option:

- L** Laminate
- W** Wood
- S** Steel

② Lock Option:

- L** Locking, add **\$73.91** list
- N** Non-Locking

- 2) Case wood finish color.
- 3) Door material front color.
- 4) Door material front edgeband (laminate only).
- 5) Pull trim color.*

***Note:** **\$5.36** upcharge for Metallic and accent Pull trim colors.

Overhead Storage Unit — Sliding Doors — Wood Case

Dual Sided

Description	Outside Depth	Outside Width	Total Inside Width	Number	①	②	Case Wood Group A				Wood Door Group A	Wood Door Group B
							Steel Door A	Steel Door B	Laminate Door A	Laminate Door B		
Sliding Door/Right												
	18"(457mm)	48"(1219mm)	46.5"(1181mm)	QUS2-1648-DW	■	V ■	\$2463.31	\$2892.36	\$2970.53	\$2447.37	\$2458.08	\$2650.49
		54"(1372mm)	52.5"(1334mm)	QUS2-1654-DW	■	V ■	2663.34	3113.12	3196.64	2703.10	2714.88	2915.86
		60"(1524mm)	58.5"(1486mm)	QUS2-1660-DW	■	V ■	2929.78	3400.29	3489.16	2943.84	2956.69	3166.24
		66"(1676mm)	64.5"(1638mm)	QUS2-1666-DW	■	V ■	3181.23	3672.47	3766.69	3171.72	3185.64	3403.76
		72"(1829mm)	70.5"(1791mm)	QUS2-1672-DW	■	V ■	3419.82	3931.79	4031.36	2258.05	2267.69	2451.53
Sliding Door/Left												
	18"(457mm)	48"(1219mm)	46.5"(1181mm)	QUS2-1648-EW	■	V ■	\$2463.31	\$2892.36	\$2970.53	\$2447.37	\$2458.08	\$2650.49
		54"(1372mm)	52.5"(1334mm)	QUS2-1654-EW	■	V ■	2663.34	3113.12	3196.64	2703.10	2714.88	2915.86
		60"(1524mm)	58.5"(1486mm)	QUS2-1660-EW	■	V ■	2929.78	3400.29	3489.16	2943.84	2956.69	3166.24
		66"(1676mm)	64.5"(1638mm)	QUS2-1666-EW	■	V ■	3181.23	3672.47	3766.69	3171.72	3185.64	3403.76
		72"(1829mm)	70.5"(1791mm)	QUS2-1672-EW	■	V ■	3419.82	3931.79	4031.36	2359.81	2369.45	2553.29

Description	Outside Depth	Outside Width	Total Inside Width	Number	①	②	Case Wood Group B				Wood Door Group A	Wood Door Group B
							Steel Door A	Steel Door B	Laminate Door A	Laminate Door B		
Sliding Door/Right												
	18"(457mm)	48"(1219mm)	46.5"(1181mm)	QUS2-1648-DW	■	V ■	\$2565.07	\$2994.12	\$3072.29	\$2559.84	\$2570.55	\$2762.96
		54"(1372mm)	52.5"(1334mm)	QUS2-1654-DW	■	V ■	2775.81	3225.59	3309.11	2826.28	2838.06	3039.04
		60"(1524mm)	58.5"(1486mm)	QUS2-1660-DW	■	V ■	3052.96	3523.47	3612.34	3077.73	3090.58	3300.13
		66"(1676mm)	64.5"(1638mm)	QUS2-1666-DW	■	V ■	3315.12	3806.36	3900.58	3316.32	3330.24	3548.36
		72"(1829mm)	70.5"(1791mm)	QUS2-1672-DW	■	V ■	3564.42	4076.39	4175.96	2359.81	2369.45	2553.29
Sliding Door/Left												
	18"(457mm)	48"(1219mm)	46.5"(1181mm)	QUS2-1648-EW	■	V ■	\$2565.07	\$2994.12	\$3072.29	\$2559.84	\$2570.55	\$2762.96
		54"(1372mm)	52.5"(1334mm)	QUS2-1654-EW	■	V ■	2775.81	3225.59	3309.11	2847.70	2859.48	3060.46
		60"(1524mm)	58.5"(1486mm)	QUS2-1660-EW	■	V ■	3074.38	3544.89	3633.76	3120.58	3133.43	3342.98
		66"(1676mm)	64.5"(1638mm)	QUS2-1666-EW	■	V ■	3357.97	3849.21	3943.43	3348.46	3362.38	3580.50
		72"(1829mm)	70.5"(1791mm)	QUS2-1672-EW	■	V ■	3596.56	4108.53	4208.10	81.41	92.12	81.41

Overhead Storage Unit Accessories

Description	Number	Trim	
		A	B
Top Mount Bracket			
Compose Steel Trim			
	QZBT-0000-PPH	\$ 92.12	\$ 81.41
Compose Aluminum Trim			
	QZBT-0000-PPA	\$ 92.12	\$239.94
UniGroup Too			
	QEBT-0000-PP	\$256.01	\$219.59
PREMISE — Off Modular			
	QNGB-0000-PZ	\$235.66	\$256.01
PREMISE — On Modular			
	QNGB-0000-PM	\$219.59	\$235.66

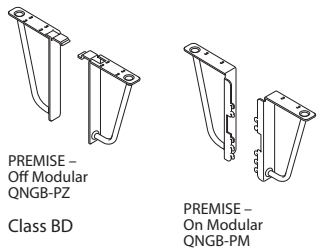
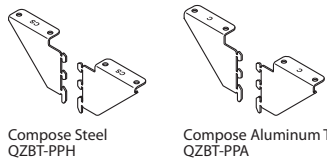

Features

- Includes brackets and attachment hardware.
- Use to center mount Beside overhead storage unit to Compose, UniGroup Too, and PREMISE Panel systems.

To Order, Specify:

- 1) Product number.
- 2) Trim color.

Specification Tips

- Order appropriate Top mount bracket.
- For trim lengths over 60”(1524mm) order two kits.
- PREMISE Off Modular and PREMISE on Modular Top Mount Bracket may be used with a monolithic panel or a stackable panel configuration.
- PREMISE Off Modular and PREMISE On Modular Top Mount Bracket **cannot** be used with 10”(254mm) stack pads or kits.
- PREMISE On Modular Top Mount Bracket installed in connector slots on same size panel or on a combination of panels which equal the width of the storage unit.
- For PREMISE Off Modular Top Mount Bracket used with a stackable panel: the panel must have a 16”(406mm) high structural fabric stack pad/kit with a structural cross bar. Structural cross bar must be at the top of the panel configuration.
- Foundation element must have a grooved cap top cap when using PREMISE Off Modular Top Mount Bracket.

Off Modular Top Trim Mounting 18”-120” for Compose

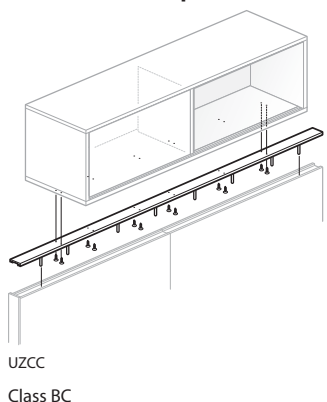

Number	Trim	
	A	B
UZCC-0018-A	\$ 85.98	\$ 87.13
UZCC-0024-A	97.08	98.81
UZCC-0030-A	108.18	109.91
UZCC-0036-A	119.28	121.01
UZCC-0042-A	130.38	132.11
UZCC-0048-A	141.48	143.21
UZCC-0051-A	147.03	148.76
UZCC-0054-A	152.58	154.31
UZCC-0060-A	163.68	165.41
UZCC-0063-A	195.84	197.57
UZCC-0066-A	201.39	203.12
UZCC-0072-A	212.49	214.22
UZCC-0075-A	242.34	244.07
UZCC-0078-A	247.89	249.62
UZCC-0084-A	258.99	260.72
UZCC-0090-A	270.09	271.82
UZCC-0096-A	281.19	282.92
UZCC-0102-A	292.29	294.02
UZCC-0108-A	303.39	305.12
UZCC-0114-A	314.49	316.22
UZCC-0120-A	325.59	327.32

Features

- Includes Full Profile Aluminum Off Modular top trim and attachment hardware.
- Use to center mount Beside overhead storage unit to modular or off modular applications.

To Order, Specify:

- 1) Product number.
- 2) Trim color.

Specification Tips

- Designed to be used in full profile aluminum top trim applications only.
- Recommended panel height is 42”(1067mm) to 50”(1270mm).

Overhead Storage Unit Accessories

	Number	Price
Ganging Tie Plate Bracket	QUUG-0000	\$40.03

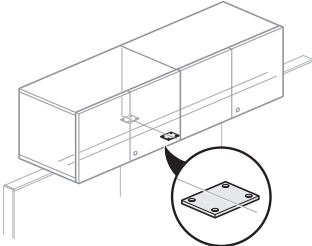

QUUG

Features

- Includes one bracket and attachment hardware.
- Available in Charcoal only.

Specification Tips

- Designed to be used with Beside overhead storage unit in top mount positions only.
- Not designed to be used with PREMISE.
- Quantity of brackets dependent on application use.

To Order, Specify:

- 1) Product number.
(No finish specification required.)

Task Lighting

	Height	Depth	Width	Number	Price
Adaptable Electronic Ballast Task Light	1.375"(25mm)	4 1/4"(105mm)	24"(610mm)	LUTS-0024-16UEP	\$213.34
			30"(762mm)	LUTS-0030-16UEP	220.22
			42"(1067mm)	LUTS-0042-16UEP	233.98
			54"(1372mm)	LUTS-0054-16UEP	247.74

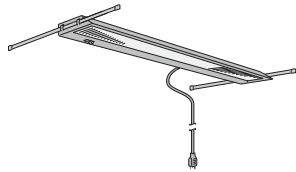

LUTS-16UEP
Class CA – SIN 711-1;
Discount Group I

Features

- Includes mounting brackets, black power cord, prismatic lens, low mercury content, and T-8 optic fluorescent lamp with 3500K color temperature.
- Six foot cord is factory installed on right side; may be field-installed on the left-hand side, 42"(1067mm)- and 54"(1372mm)-wide units only.
- Nine foot cord is available as a specified option.
- Provides task lighting beneath shelves or overhead storage units.
- **For use with 120 volt 60 hertz electrical systems only.**
- Available in charcoal only.

Specification Tips

- **A task light must be a minimum of 6"(152mm) less than the vertical storage unit to which it is attached.**
- Task lights may be adjusted front-to-back.
- Task light is less than the width of the unit to which it is attached, it may be adjusted side-to-side.
- Separately specified task light mounting brackets (JBBT-1) for X Series vertical storage unit applications.

To Order, Specify:

- 1) Product number.
(No finish specification required.)

Batwing Lens Specification:

To specify, replace **P** with **B** in the product number and add **\$19.49** list.

Example: LUTS-0030-16UEB

Chicago Specification:

To specify, replace **1** with **C** in the product number and add **\$89.48** list.

Example: LUTS-0030-C6UEP

Chicago only: Plug includes 3 AMP resettable circuit breaker.

9' Cord Option

To specify, replace **6** with **9** and add **\$39.01** list.

Example: LUTS-0030-19UEP

Adaptable Light Skirt

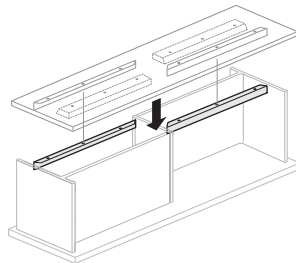

QULS
Class BD – SIN 711-3;
Discount Group XII

Actual Width	Nominal Width	Number	Trim	
			A	B
20.69"(508mm)	24"(610mm)	QULS-0024	\$ 64.27	\$ 70.70
26.69"(660mm)	30"(762mm)	QULS-0030	74.98	82.48
32.69"(813mm)	36"(914mm)	QULS-0036	85.69	94.26
38.69"(965mm)	42"(1067mm)	QULS-0042	96.40	106.04
21.94"(533mm)	48"(1219mm)	QULS-0048	107.11	117.82
24.94"(610mm)	54"(1372mm)	QULS-0054	117.82	130.67
27.94"(686mm)	60"(1524mm)	QULS-0060	128.53	141.38
30.94"(762mm)	66"(1676mm)	QULS-0066	139.24	154.23
33.94"(838mm)	72"(1829mm)	QULS-0072	149.95	164.94

Features

- Includes light skirt with attachment hardware.
- Used to visually conceal the Adaptable Task Light.
- Units 48"(1219mm) wide and greater include 2 light skirts. See actual widths for dimensions.

Specification Tip

- To be used with Beside stanchion kits application only.

To Order, Specify:

- 1) Product number.
- 2) Trim color.

This page intentionally blank

Belong Screens

Screen — Back

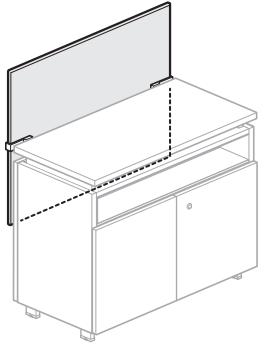

SUFB

Features

- Includes screen and attachment hardware.
- Fabric surface is non-tackable.
- Laminate surface is high pressure laminate with 1mm edgeband.
- Wood surface is wood veneer surface with 1mm edgeband.
- Screen and brackets are field installed.

Specification Tips

- **Attaches to back of Reside Desking and most Adaptable Worksurfaces and Beside Storage.**
- **Designed for single sided applications.**
- Specify screen width to allow 12”(305mm) clearance for top feed applications.
- Screens are non-load bearing Screens can be specified to match width of component for any size.
- Screens with clear glass specified are clear above and below the Reside desking worksurface or storage unit.
- Screen mounting:
 - 19”(483mm) High: 4.25”(108mm) above worksurface or Beside Lower Storage 13”(330mm) from bottom of worksurface to bottom of screen
 - 27” High: 12.25”(311mm) above worksurface; 13”(330mm) from bottom of worksurface to bottom of screen
- Screen Thickness:
 - Fabric, laminate, and wood – 0.56”(14mm)
 - Glass – 0.24”(6mm)
- Gap between screen and horizontal surface allows installation of Belong Tool Rail.
- Refer to Specification Guide for additional guidelines.

To Order, Specify:

- 1) Product number.
- 2) Surface Colors Options:
 - Fabric:
 - Fabric Color
 - Laminate:
 - Laminate Surface Color:
 - Edgeband trim color
 - Wood:
 - Wood Finish Color
 - Glass:
 - Glass Finish
 - 9T-1C Clear (Grade A)
 - 9T-E21 Satin Etched (Grade C)
- 3) Trim color for bracket.

Notes: **\$2.16** upcharge list for Metallic and accent trim colors.
Premium laminate wood grain direction is vertical.

Height	Width	Number	Fabric Grade						
			A	B	C	D	E	F	G
Fabric									
19”(483mm)	24”(610mm)	SUFB-1924-FU	\$205.03	\$208.81	\$212.59	\$216.37	\$220.15	\$226.24	\$229.67
	30”(762mm)	SUFB-1930-FU	224.50	229.90	235.52	241.25	246.97	255.77	260.82
	36”(914mm)	SUFB-1936-FU	243.97	250.99	258.45	266.13	273.79	285.30	291.97
	42”(1067mm)	SUFB-1942-FU	263.44	272.08	281.38	291.01	300.61	314.83	323.12
	48”(1219mm)	SUFB-1948-FU	282.91	293.17	304.31	315.89	327.43	344.36	354.27
	54”(1372mm)	SUFB-1954-FU	302.38	314.26	327.24	340.77	354.25	373.89	385.42
27”(686mm)	60”(1524mm)	SUFB-1960-FU	321.85	335.35	350.17	365.65	381.07	403.42	416.57
	24”(610mm)	SUFB-2724-FU	\$230.95	\$239.05	\$247.15	\$255.25	\$263.35	\$276.40	\$283.75
	30”(762mm)	SUFB-2730-FU	250.42	260.14	270.08	280.13	290.17	305.93	314.90
	36”(914mm)	SUFB-2736-FU	269.89	281.23	293.01	305.01	316.99	335.46	346.05
	42”(1067mm)	SUFB-2742-FU	289.36	302.32	315.94	329.89	343.81	364.99	377.20
	48”(1219mm)	SUFB-2748-FU	308.83	323.41	338.87	354.77	370.63	394.52	408.35
54”(1372mm)	SUFB-2754-FU	328.30	344.50	361.80	379.65	397.45	424.05	439.50	
	60”(1524mm)	SUFB-2760-FU	347.77	365.59	384.73	404.53	424.27	453.58	470.65

Height	Width	Number	Laminate	
			A	B
Laminate				
19”(483mm)	24”(610mm)	SUFB-1924-DU	\$135.13	\$143.51
	30”(762mm)	SUFB-1930-DU	143.78	152.87
	36”(914mm)	SUFB-1936-DU	152.43	162.23
	42”(1067mm)	SUFB-1942-DU	161.08	171.59
	48”(1219mm)	SUFB-1948-DU	169.73	180.95
	54”(1372mm)	SUFB-1954-DU	178.38	190.31
27”(686mm)	60”(1524mm)	SUFB-1960-DU	187.03	199.67
	24”(610mm)	SUFB-2724-DU	\$161.05	\$171.59
	30”(762mm)	SUFB-2730-DU	169.70	180.95
	36”(914mm)	SUFB-2736-DU	178.35	190.31
	42”(1067mm)	SUFB-2742-DU	187.00	199.67
	48”(1219mm)	SUFB-2748-DU	195.65	209.03
54”(1372mm)	SUFB-2754-DU	204.30	218.39	
	60”(1524mm)	SUFB-2760-DU	212.95	227.75

Belong Screens

Height	Width	Number	Wood Group	
			A	B
Wood				
19"(483mm)	24"(610mm)	SUFB-1924-WU	\$385.23	\$392.25
	30"(762mm)	SUFB-1930-WU	402.53	411.07
	36"(914mm)	SUFB-1936-WU	419.83	429.89
	42"(1067mm)	SUFB-1942-WU	437.13	448.71
	48"(1219mm)	SUFB-1948-WU	454.43	467.53
	54"(1372mm)	SUFB-1954-WU	471.73	486.35
	60"(1524mm)	SUFB-1960-WU	489.03	505.17
27"(686mm)	24"(610mm)	SUFB-2724-WU	\$411.15	\$422.49
	30"(762mm)	SUFB-2730-WU	428.45	441.31
	36"(914mm)	SUFB-2736-WU	445.75	460.13
	42"(1067mm)	SUFB-2742-WU	463.05	478.95
	48"(1219mm)	SUFB-2748-WU	480.35	497.77
	54"(1372mm)	SUFB-2754-WU	497.65	516.59
	60"(1524mm)	SUFB-2760-WU	514.95	535.41
Glass				
Height	Width	Number	Glass	
			A	C
19"(483mm)	24"(610mm)	SUFB-1924-GU	\$313.61	\$347.78
	30"(762mm)	SUFB-1930-GU	341.73	377.20
	36"(914mm)	SUFB-1936-GU	369.85	406.62
	42"(1067mm)	SUFB-1942-GU	397.97	436.04
	48"(1219mm)	SUFB-1948-GU	434.09	473.46
	54"(1372mm)	SUFB-1954-GU	470.21	510.88
	60"(1524mm)	SUFB-1960-GU	506.33	548.30
27"(686mm)	24"(610mm)	SUFB-2724-GU	\$382.81	\$424.82
	30"(762mm)	SUFB-2730-GU	410.93	454.24
	36"(914mm)	SUFB-2736-GU	439.05	483.66
	42"(1067mm)	SUFB-2742-GU	467.17	513.08
	48"(1219mm)	SUFB-2748-GU	503.29	550.50
	54"(1372mm)	SUFB-2754-GU	539.41	587.92
	60"(1524mm)	SUFB-2760-GU	575.53	625.34

Belong Screens

Screen — Center

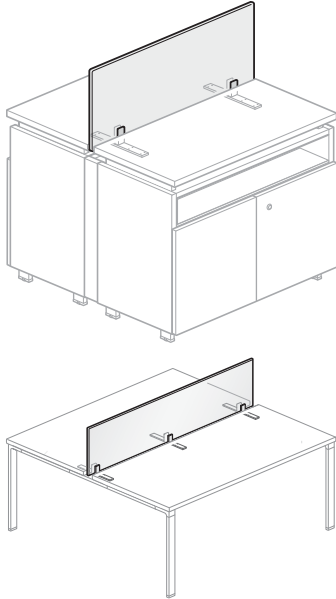

SUPC

Features

- Includes screen and attachment hardware.
- Fabric surface is non-tackable.
- Laminate surface is high pressure laminate with 1mm edgeband.
- Wood surface is wood veneer surface with 1mm edgeband.
- Screen and brackets are field installed.

Specification Tips

Designed for center back-to-back Reside Desking worksurface and Beside Storage.

- For ease of installation, it is required that center screen brackets are attached to only one of the two back-to-back Beside storage tops.
- Specify screen width to allow 12”(305mm) clearance for top feed applications.
- Screens can be specified to match width of component or screens can span multiple adjacent components.
- Screen Thickness:
 - Fabric, laminate, and wood – 0.56”(14mm)
 - Glass – 0.24”(6mm)
- Gap between screen and horizontal surface allows installation of Belong Tool Rail and Reside desking utility tray; 1.5”(38mm) clearance range.
- Screen is 12.25”(311mm) above worksurface top.
- Refer to Specification Guide for additional guidelines.
- Screens are designed to be used with Belong screen rail.

To Order, Specify:

1) Product number.

2) Surface Colors Options:

Fabric:

–Fabric Color

Laminate:

–Laminate Surface Color:

–Edgeband trim color

Wood:

–Wood Finish Color

Glass:

–Glass Finish

9T-1C Clear (Grade A)

9T-E21 Satin Etched (Grade C)

3) Trim color for bracket.

Notes: \$2.16 upcharge list for Metallic and accent trim colors.

Premium laminate wood grain direction is vertical.

Height	Width	Number	Fabric Grade						
			A	B	C	D	E	F	G
Fabric									
14”(356mm)	24”(610mm)	SUPC-1424-FU	\$209.24	\$213.41	\$218.01	\$223.04	\$228.05	\$234.75	\$238.92
	30”(762mm)	SUPC-1430-FU	223.30	229.63	236.40	244.67	251.84	261.79	268.12
	36”(914mm)	SUPC-1436-FU	237.36	245.85	254.79	266.30	275.63	288.83	297.32
	42”(1067mm)	SUPC-1442-FU	251.42	262.07	273.18	287.93	299.42	315.87	326.52
	48”(1219mm)	SUPC-1448-FU	265.48	278.29	291.57	309.56	323.21	342.91	355.72
	54”(1372mm)	SUPC-1454-FU	279.54	294.51	309.96	331.19	347.00	369.95	384.92
	60”(1524mm)	SUPC-1460-FU	293.60	310.73	328.35	352.82	370.79	396.99	414.12

Height	Width	Number	Laminate	
			A	B
Laminate				
14”(356mm)	24”(610mm)	SUPC-1424-DU	\$159.89	\$162.49
	30”(762mm)	SUPC-1430-DU	170.71	174.39
	36”(914mm)	SUPC-1436-DU	181.53	186.29
	42”(1067mm)	SUPC-1442-DU	192.35	198.19
	48”(1219mm)	SUPC-1448-DU	203.17	210.09
	54”(1372mm)	SUPC-1454-DU	213.99	221.99
	60”(1524mm)	SUPC-1460-DU	224.81	233.89
	66”(1676mm)	SUPC-1466-DU	235.63	245.79
	72”(1829mm)	SUPC-1472-DU	246.45	257.69
	78”(1981mm)	SUPC-1478-DU	257.27	269.59
	84”(2134mm)	SUPC-1484-DU	268.09	281.49
	90”(2286mm)	SUPC-1490-DU	278.91	293.39
	96”(2438mm)	SUPC-1496-DU	289.73	305.29

Height	Width	Number	Wood Group	
			A	B
Wood				
14”(356mm)	24”(610mm)	SUPC-1424-WU	\$399.19	\$405.03
	30”(762mm)	SUPC-1430-WU	415.41	425.58
	36”(914mm)	SUPC-1436-WU	431.63	446.13
	42”(1067mm)	SUPC-1442-WU	447.85	466.68
	48”(1219mm)	SUPC-1448-WU	464.07	487.23
	54”(1372mm)	SUPC-1454-WU	480.29	507.78
	60”(1524mm)	SUPC-1460-WU	496.51	528.33
	66”(1676mm)	SUPC-1466-WU	512.73	548.88
	72”(1829mm)	SUPC-1472-WU	528.95	569.43
	78”(1981mm)	SUPC-1478-WU	545.17	589.98
	84”(2134mm)	SUPC-1484-WU	561.39	610.53
	90”(2286mm)	SUPC-1490-WU	577.61	631.08
	96”(2438mm)	SUPC-1496-WU	593.83	651.63

Belong Screens

Screen — Center (cont'd)	Height	Width	Number	Glass	
				A	C
Glass					
	14"(356mm)	24"(610mm)	SUPC-1424-GU	\$224.80	\$262.65
		30"(762mm)	SUPC-1430-GU	237.78	276.61
		36"(914mm)	SUPC-1436-GU	250.76	290.57
		42"(1067mm)	SUPC-1442-GU	263.74	304.53
		48"(1219mm)	SUPC-1448-GU	284.72	326.49
		54"(1372mm)	SUPC-1454-GU	305.70	348.45
		60"(1524mm)	SUPC-1460-GU	326.68	370.41
		66"(1676mm)	SUPC-1466-GU	347.66	392.37
		72"(1829mm)	SUPC-1472-GU	368.64	414.33
		78"(1981mm)	SUPC-1478-GU	389.62	436.29
		84"(2134mm)	SUPC-1484-GU	410.60	458.25
		90"(2286mm)	SUPC-1490-GU	431.58	480.21
		96"(2438mm)	SUPC-1496-GU	452.56	502.17

Bracket — Screen — For use with 120° Reside worksurface

	Number	Trim	
		A	B
	SUCB-0000	\$79.53	\$85.22

Feature

- Includes one bracket.

Specification Tips

- For use with Reside 120° worksurface application with separately specified Belong Center Screen.
- Order one Bracket for each Center Screen; bracket replaces one of the standard brackets shipped with Center Screen.

To Order, Specify:

- 1) Product
- 2) Trim color.

Storage Pantry — 28" High

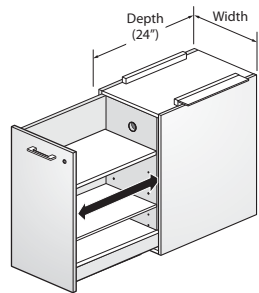
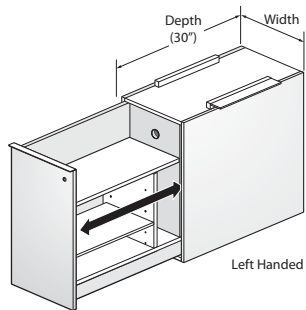

QLG1-ZLLF

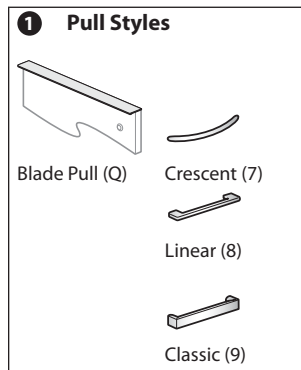

Features

- Includes: Laminate or wood case with sliding pull out storage pantry, spacer, glides and one center caster.
- Spacer: 1.18"(30mm) high.
- Glides: Adjustment range: 0.78"(20mm).
- Center Caster: Height adjustable caster located in the center front of the pull out storage pantry. Adjustment range: 1"(25mm).
- Full extension slides.
- Storage pantry standard with fixed shelf between upper and lower storage compartments.
- Pantry drilled with holes in 2"(51mm) increments to accept separately specified adjustable shelf.
- Pantry interior standard in laminate.
 - Laminate case has matching laminate interior.
 - Veneer case has specifiable laminate interior.
- 15"(381mm) and 18"(457mm) wide units accommodate standard height binders in lower storage compartment.
- Crescent, Linear and Classic pulls are brushed nickel finish. Blade pull available in trim color.
- Optional USB Power Cutout comes with a precut hole to accept a round Bezel Utility Module.
- Bezel Utility Module is separately specified.
- Lock option standard in chrome.
- Digital locks available. For this and other lock options, refer to Lock Program Price List.

Specification Tips

- Maximum load capacity of 125 pounds.
- For use beneath a separately specified adaptable worksurface; storage pantry standard with spacer provides a 29"(737mm) finished height worksurface.
- Must be attached under an adaptable worksurface equal to or greater than pantry depth.
- Not for use with Reside or Intuity worksurfaces.
- When using pantry to support one end of a worksurface in a panel application, secure worksurface to panel using a corner bracket, cantilever, or pantry to panel bracket; separately specified.
- Separately specified and field installed options include:
 - Finished back
 - Bezel Utility Module (must be installed prior to installing a finished back)
 - Personal drawer
 - Hanging file drawer
 - Adjustable shelf
 - Upper and lower slat rails
- 28"(711mm) high pantry not available with inner pantry markerboard side panel option.
- One personal or hanging file drawer per 15"(381mm) or 18"(457mm) deep pantry is allowed. Field installed beneath fixed shelf.
- Upper storage compartment is 6.38"(162mm) high.
- Lower Storage compartment is 13.64"(346mm) high.
- Lower storage compartment of 24"(610mm) deep pantry consists of one storage section. 30"(762mm) deep pantry lower storage compartment comprised of two storage compartments.
- Door Orientation: If pantry is located on left-hand side of the user it is left-handed. If located on right-hand side of user it is right-hand.
- Not for use with Saddle Cover.
- Refer to Specification Guide for planning information and actual dimensions.

To Order, Specify:

- 1) Product number, including:

1 Pull Option: (see side bar)

- Q** Blade Pull, add **\$40.00** list
- 7** Crescent Pull
- 8** Linear Pull
- 9** Classic Pull

2 User Orientation:

- L** Left-Hand
- R** Right-Hand

3 Lock Option:

- L** Locking, add **\$40.00** list
- N** Non-Locking

4 USB Power Cutout Option:

- N** No power cutout
- Y** Bezel Utility Module power cutout, add **\$50.00** list

- 2) Case exterior laminate or wood finish.
- 3) Case exterior laminate edgeband color.
- 4) Front laminate or wood finish color.
- 5) Front laminate edgeband color (if applicable).
- 6) Trim color (Spacer and Blade pull if applicable).

Storage Pantry — 28" High

Height	Depth	Width	Number	①②③④	Case Laminate A Front - Laminate		Case Laminate B Front - Laminate	
					A	B	A	B
Laminate Case/Laminate Front, Worksurface Depth								
28"(711mm)	24"(610mm)	12"(305mm)	QLG1-2812-ZLLF	■ ■ ■ ■	\$1830.00	\$1855.19	\$1940.97	\$1966.16
		15"(381mm)	QLG1-2815-ZLLF	■ ■ ■ ■	1872.00	1897.41	1985.67	2011.08
		18"(457mm)	QLG1-2818-ZLLF	■ ■ ■ ■	1914.00	1939.41	2030.37	2055.78
30"(762mm)	12"(305mm)	12"(305mm)	QLM1-2812-ZLLF	■ ■ ■ ■	\$1950.00	\$1975.19	\$2069.61	\$2094.80
		15"(381mm)	QLM1-2815-ZLLF	■ ■ ■ ■	1992.00	2017.41	2114.31	2139.72
		18"(457mm)	QLM1-2818-ZLLF	■ ■ ■ ■	2034.00	2059.41	2159.01	2184.42

Height	Depth	Width	Number	①②③④	Case Laminate A Front - Wood		Case Laminate B Front - Wood	
					Group A	Group B	Group A	Group B
Laminate Case/Wood Front, Worksurface Depth								
28"(711mm)	24"(610mm)	12"(305mm)	QLG1-2812-ZLWF	■ ■ ■ ■	\$2125.00	\$2177.51	\$2235.97	\$2288.48
		15"(381mm)	QLG1-2815-ZLWF	■ ■ ■ ■	2174.50	2228.35	2288.17	2342.02
		18"(457mm)	QLG1-2818-ZLWF	■ ■ ■ ■	2216.50	2270.35	2332.87	2386.72
30"(762mm)	12"(305mm)	12"(305mm)	QLM1-2812-ZLWF	■ ■ ■ ■	\$2245.00	\$2297.51	\$2364.61	\$2417.12
		15"(381mm)	QLM1-2815-ZLWF	■ ■ ■ ■	2294.50	2348.35	2416.81	2470.66
		18"(457mm)	QLM1-2818-ZLWF	■ ■ ■ ■	2336.50	2390.35	2461.51	2515.36

Height	Depth	Width	Number	①②③④	Case Wood Group A Front - Laminate		Case Wood Group B Front - Laminate	
					A	B	A	B
Wood Case/Laminate Front, Worksurface Depth								
28"(711mm)	24"(610mm)	12"(305mm)	QLG1-2812-ZWLL	■ ■ ■ ■	\$2462.00	\$2487.19	\$2574.51	\$2599.70
		15"(381mm)	QLG1-2815-ZWLL	■ ■ ■ ■	2519.00	2544.41	2634.18	2659.59
		18"(457mm)	QLG1-2818-ZWLL	■ ■ ■ ■	2576.00	2601.41	2693.85	2719.26
30"(762mm)	12"(305mm)	12"(305mm)	QLM1-2812-ZWLL	■ ■ ■ ■	\$2678.00	\$2703.19	\$2807.61	\$2832.80
		15"(381mm)	QLM1-2815-ZWLL	■ ■ ■ ■	2735.00	2760.41	2867.28	2892.69
		18"(457mm)	QLM1-2818-ZWLL	■ ■ ■ ■	2792.00	2817.41	2926.95	2952.36

Height	Depth	Width	Number	①②③④	Case Wood Group A Front - Wood		Case Wood Group B Front - Wood	
					Group A	Group B	Group A	Group B
Wood Case/Wood Front, Worksurface Depth								
28"(711mm)	24"(610mm)	12"(305mm)	QLG1-2812-ZWWL	■ ■ ■ ■	\$2757.00	\$2809.51	\$2869.51	\$2922.02
		15"(381mm)	QLG1-2815-ZWWL	■ ■ ■ ■	2821.50	2875.35	2936.68	2990.53
		18"(457mm)	QLG1-2818-ZWWL	■ ■ ■ ■	2878.50	2932.35	2996.35	3050.20
30"(762mm)	12"(305mm)	12"(305mm)	QLM1-2812-ZWWL	■ ■ ■ ■	\$2973.00	\$3025.51	\$3102.61	\$3155.12
		15"(381mm)	QLM1-2815-ZWWL	■ ■ ■ ■	3037.50	3091.35	3169.78	3223.63
		18"(457mm)	QLM1-2818-ZWWL	■ ■ ■ ■	3094.50	3148.35	3229.45	3283.30

Storage Pantry — Laminate Case and Front

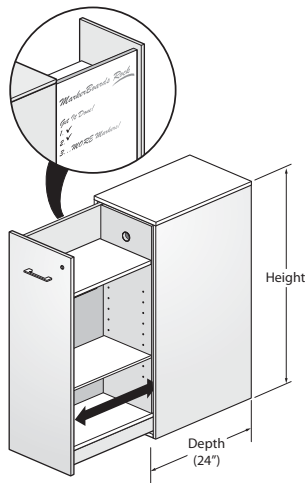
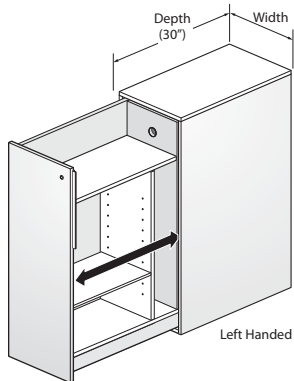

Features

- Includes: Laminate case and front sliding pull out storage pantry, glides and one center caster.
- Glides: Adjustment range: 0.78"(20mm).
- Center Caster: Height adjustable caster located in the center front of the pull out storage pantry. Adjustment range: 1"(25mm).
- Full extension slides.
- Storage pantry standard with fixed shelf between upper and lower storage compartments.
- Pantry drilled with holes in 2"(51mm) increments to accept separately specified adjustable shelf.
- Pantry interior standard in laminate.
 - Laminate case has matching laminate interior.
- 15"(381mm) and 18"(457mm) wide units accommodate standard height binders in lower storage compartment.
- Optional USB Power Cutout Option comes with a precut hole to accept a round Bezel Utility Module. Bezel Utility Module is separately specified.
- Available with laminate or markerboard inner pantry side panel option. Inner pantry side panel is located on the non-user side of the pull out pantry. Laminate option matches case exterior laminate.
- Crescent, Linear and Classic pulls are brushed nickel finish. Blade pull available in trim color.
- Lock plug standard in chrome.
- Digital locks available. For this and other lock options, refer to Lock Program Price List.

Specification Tips

- 40"(1016mm) and 48"(1219mm) high pantry supports maximum load capacity of 180 pounds.
- 12"(305mm) wide units must be attached. (Refer to specification guidelines).
- 15"(381mm) and 18"(457mm) wide units can be freestanding.
- Extended depth pantry designed for back to back application to fill the gap on a bench or panel application.
- Separately specified and field installed options include:
 - Finished back
 - Bezel Utility Module (must be installed prior to installing a finished back)
 - Personal drawer
 - Hanging file drawer
 - Adjustable shelf
 - Upper and lower slat rails
- Personal or hanging file drawer allowed on 15"(381mm) or 18"(457mm) deep pantry. Field installed beneath fixed or adjustable shelf.
- Upper storage compartment is 6.38"(162mm) high.
- Lower Storage compartment height:
 - 40"(1016mm) high pantry - 27.98"(711mm) high
 - 48"(1219mm) high pantry - 35.98"(914mm) high
- Lower storage compartment of 24"(610mm) deep pantry consists of one storage section. 30"(762mm) deep pantry lower storage compartment comprised of one storage compartment and one valet with coat hook.
- User Orientation: If pantry is located on left-hand side of the user it is left-handed. If located on right-hand side of user it is right-hand
- Refer to Specification Guide for planning information and actual dimensions.
- The following are recommended to maintain markerboard appearance:
 - Dry erase marker kit (includes holder, six markers and eraser), order part# 7062-8001.
 - Markerboard cleaner and conditioner, order part# 7031-7001.
 - Markerboard spray cleaner, order part# 7031-7002.

2 Pull Styles

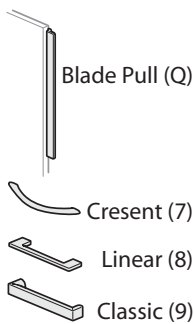

To Order, Specify:

1) Product number, including:

1 Inner Pantry Side Panel Option:

- Z** Laminate
- Y** Markerboard, add **\$40.00** list

2 Pull Option: (see side bar)

- Q** Blade Pull, add **\$40.00** list
- 7** Crescent Pull
- 8** Linear Pull
- 9** Classic Pull

3 User Orientation:

- L** Left-Hand
- R** Right-Hand

4 Lock Option:

- L** Locking, add **\$40.00** list
- N** Non-Locking

5 USB Power Cutout Option:

- N** No power cutout
- Y** Bezel Utility Module power cutout, add **\$50.00** list

- 2) Case exterior laminate color.
- 3) Case exterior laminate edgeband color.
- 4) Front laminate color.
- 5) Front laminate edgeband color.
- 6) Pull trim color (Blade pull only).

Storage Pantry — Laminate Case and Front

Height	Depth	Width	Number	①	②	③	④	⑤	Case Laminate A Front - Laminate		Case Laminate B Front - Laminate			
									A	B	A	B		
Worksurface Depth														
40"(1016mm)	24"(610mm)	12"(305mm)	QLG1-4012-	LLF	■	■	■	■	■	\$1932.00	\$1958.87	\$2049.93	\$2076.80	
		15"(381mm)	QLG1-4015-	LLF	■	■	■	■	■	1974.00	2001.09	2094.63	2121.72	
		18"(457mm)	QLG1-4018-	LLF	■	■	■	■	■	2016.00	2043.09	2139.33	2166.42	
	30"(762mm)	12"(305mm)	QLM1-4012-	LLF	■	■	■	■	■	\$2052.00	\$2078.87	\$2178.57	\$2205.44	
		15"(381mm)	QLM1-4015-	LLF	■	■	■	■	■	2094.00	2121.09	2223.27	2250.36	
		18"(457mm)	QLM1-4018-	LLF	■	■	■	■	■	2136.00	2163.09	2267.97	2295.06	
	48"(1219mm)	24"(610mm)	12"(305mm)	QLG1-4812-	LLF	■	■	■	■	\$2020.00	\$2047.99	\$2142.57	\$2170.56	
			15"(381mm)	QLG1-4815-	LLF	■	■	■	■	2062.00	2090.21	2187.27	2215.48	
			18"(457mm)	QLG1-4818-	LLF	■	■	■	■	2104.00	2132.21	2231.97	2260.18	
30"(762mm)		12"(305mm)	QLM1-4812-	LLF	■	■	■	■	■	\$2140.00	\$2167.99	\$2271.21	\$2299.20	
		15"(381mm)	QLM1-4815-	LLF	■	■	■	■	■	2182.00	2210.21	2315.91	2344.12	
		18"(457mm)	QLM1-4818-	LLF	■	■	■	■	■	2224.00	2252.21	2360.61	2388.82	
Extended Depth														
40"(1016mm)	25.5"(648mm)	12"(305mm)	QLG2-4012-	LLF	■	■	■	■	■	\$1959.00	\$1985.87	\$2076.93	\$2103.80	
		15"(381mm)	QLG2-4015-	LLF	■	■	■	■	■	2001.00	2028.09	2121.63	2148.72	
		18"(457mm)	QLG2-4018-	LLF	■	■	■	■	■	2043.00	2070.09	2166.33	2193.42	
	31.5"(800mm)	12"(305mm)	QLM2-4012-	LLF	■	■	■	■	■	\$2094.00	\$2120.87	\$2220.57	\$2247.44	
		15"(381mm)	QLM2-4015-	LLF	■	■	■	■	■	2136.00	2163.09	2265.27	2292.36	
		18"(457mm)	QLM2-4018-	LLF	■	■	■	■	■	2178.00	2205.09	2309.97	2337.06	
	48"(1219mm)	25.5"(648mm)	12"(305mm)	QLG2-4812-	LLF	■	■	■	■	\$2051.00	\$2078.99	\$2173.57	\$2201.56	
			15"(381mm)	QLG2-4815-	LLF	■	■	■	■	■	2093.00	2121.21	2218.27	2246.48
			18"(457mm)	QLG2-4818-	LLF	■	■	■	■	■	2135.00	2163.21	2262.97	2291.18
31.5"(800mm)		12"(305mm)	QLM2-4812-	LLF	■	■	■	■	■	\$2186.00	\$2213.99	\$2317.21	\$2345.20	
		15"(381mm)	QLM2-4815-	LLF	■	■	■	■	■	2228.00	2256.21	2361.91	2390.12	
		18"(457mm)	QLM2-4818-	LLF	■	■	■	■	■	2270.00	2298.21	2406.61	2434.82	

Storage Pantry — Laminate Case with Wood Front

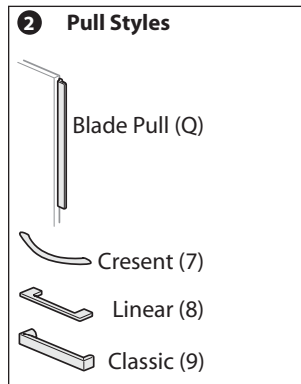
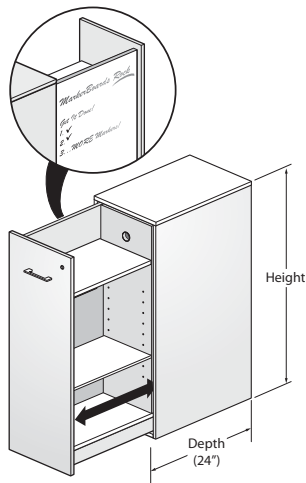
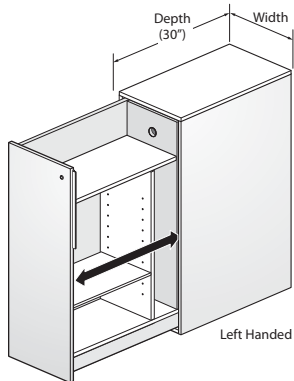

Features

- Includes: Laminate case with wood front sliding pull out storage pantry, glides and one center caster.
- Glides: Adjustment range: 0.78"(20mm).
- Center Caster: Height adjustable caster located in the center front of the pull out storage pantry. Adjustment range: 1"(25mm)
- Full extension slides.
- Storage pantry standard with fixed shelf between upper and lower storage compartments.
- Pantry drilled with holes in 2"(51mm) increments to accept separately specified adjustable shelf.
- Pantry interior standard in laminate.
–Laminate case has matching laminate interior.
- 15"(381mm) and 18"(457mm) wide units accommodate standard height binders in lower storage compartment.
- Optional USB Power Cutout Option comes with a precut hole to accept a round Bezel Utility Module. Bezel Utility Module is separately specified.
- Available with laminate or markerboard inner pantry side panel option. Inner pantry side panel is located on the non-user side of the pull-out pantry. Laminate option matches case exterior laminate.
- Crescent, Linear and Classic pulls are brushed nickel finish. Blade pull available in trim color.
- Lock plug standard in chrome.
- Digital locks available. For this and other lock options, refer to Lock Program Price List.

Specification Tips

- 40"(1016mm) and 48"(1219mm) high pantry supports maximum load capacity of 180 pounds.
- 12"(305mm) wide units must be attached. (Refer to specification guidelines).
- 15"(381mm) and 18"(457mm) wide units can be freestanding.
- Extended depth pantry designed for back to back application to fill the gap on a bench or panel application.
- Separately specified and field installed options include:
 - Finished back
 - Bezel Utility Module (must be installed prior to installing a finished back)
 - Personal drawer
 - Hanging file drawer
 - Adjustable shelf
 - Upper and lower slat rails
- Personal or hanging file drawer allowed on 15"(381mm) or 18"(457mm) deep pantry. Field installed beneath fixed or adjustable shelf.
- Upper storage compartment is 6.38"(162mm) high.
- Lower Storage compartment height:
 - 40"(1016mm) high pantry - 27.98"(756mm) high
 - 48"(1219mm) high pantry - 35.98"(914mm) high
- Lower storage compartment of 24"(610mm) deep pantry consists of one storage section. 30"(762mm) deep pantry lower storage compartment comprised of one storage compartment and one valet with coat hook.
- User Orientation: If pantry is located on left-hand side of the user it is left-handed. If located on right-hand side of user it is right-hand
- Refer to Specification Guide for planning information and actual dimensions.
- The following are recommended to maintain markerboard appearance:
 - Dry erase marker kit (includes holder, six markers and eraser), order part# 7062-8001.
 - Markerboard cleaner and conditioner, order part# 7031-7001.
 - Markerboard spray cleaner, order part# 7031-7002.

To Order, Specify:

1) Product number, including:

1 Inner Pantry Side Panel Option:

- Z** Laminate
- Y** Markerboard, add **\$40.00** list

2 Pull Option: (see side bar)

- Q** Blade Pull, add **\$40.00** list
- 7** Crescent Pull
- 8** Linear Pull
- 9** Classic Pull

3 User Orientation:

- L** Left-Hand
- R** Right-Hand

4 Lock Option:

- L** Locking, add **\$40.00** list
- N** Non-Locking

5 USB Power Cutout Option:

- N** No power cutout
- Y** Bezel Utility Module power cutout, add **\$50.00** list

- 2) Case exterior laminate color.
- 3) Case exterior laminate edgeband color.
- 4) Front wood color.
- 5) Pull trim color (Blade pull only).

Storage Pantry — Laminate Case with Wood Front

Height	Depth	Width	Number	①	②	③	④	⑤	Case Laminate A Front - Wood		Case Laminate B Front - Wood	
									Group A	Group B	Group A	Group B
Worksurface Depth												
40"(1016mm)	24"(610mm)	12"(305mm)	QLG1-4012-	LWF	■	■	■	■	\$2347.00	\$2420.87	\$2464.93	\$2538.80
		15"(381mm)	QLG1-4015-	LWF	■	■	■	■	2396.50	2471.71	2517.13	2592.34
		18"(457mm)	QLG1-4018-	LWF	■	■	■	■	2438.50	2513.71	2561.83	2637.04
	30"(762mm)	12"(305mm)	QLM1-4012-	LWF	■	■	■	■	\$2467.00	\$2540.87	\$2593.57	\$2667.44
		15"(381mm)	QLM1-4015-	LWF	■	■	■	■	2516.50	2591.71	2645.77	2720.98
		18"(457mm)	QLM1-4018-	LWF	■	■	■	■	2558.50	2633.71	2690.47	2765.68
	48"(1219mm)	24"(610mm)	12"(305mm)	QLG1-4812-	LWF	■	■	■	\$2515.00	\$2603.11	\$2637.57	\$2725.68
			15"(381mm)	QLG1-4815-	LWF	■	■	■	2564.50	2653.95	2689.77	2779.22
			18"(457mm)	QLG1-4818-	LWF	■	■	■	2606.50	2695.95	2734.47	2823.92
30"(762mm)		12"(305mm)	QLM1-4812-	LWF	■	■	■	\$2635.00	\$2723.11	\$2766.21	\$2854.32	
		15"(381mm)	QLM1-4815-	LWF	■	■	■	2684.50	2773.95	2818.41	2907.86	
		18"(457mm)	QLM1-4818-	LWF	■	■	■	2726.50	2815.95	2863.11	2952.56	
Extended Depth												
40"(1016mm)	25.5"(648mm)	12"(305mm)	QLG2-4012-	LWF	■	■	■	\$2374.00	\$2447.87	\$2491.93	\$2565.80	
		15"(381mm)	QLG2-4015-	LWF	■	■	■	2423.50	2498.71	2544.13	2619.34	
		18"(457mm)	QLG2-4018-	LWF	■	■	■	2465.50	2540.71	2588.83	2664.04	
	31.5"(800mm)	12"(305mm)	QLM2-4012-	LWF	■	■	■	\$2509.00	\$2582.87	\$2635.57	\$2709.44	
		15"(381mm)	QLM2-4015-	LWF	■	■	■	2558.50	2633.71	2687.77	2762.98	
		18"(457mm)	QLM2-4018-	LWF	■	■	■	2600.50	2675.71	2732.47	2807.68	
	48"(1219mm)	25.5"(648mm)	12"(305mm)	QLG2-4812-	LWF	■	■	\$2546.00	\$2634.11	\$2668.57	\$2756.68	
			15"(381mm)	QLG2-4815-	LWF	■	■	2595.50	2684.95	2720.77	2810.22	
			18"(457mm)	QLG2-4818-	LWF	■	■	2637.50	2726.95	2765.47	2854.92	
31.5"(800mm)		12"(305mm)	QLM2-4812-	LWF	■	■	\$2681.00	\$2769.11	\$2812.21	\$2900.32		
		15"(381mm)	QLM2-4815-	LWF	■	■	2730.50	2819.95	2864.41	2953.86		
		18"(457mm)	QLM2-4818-	LWF	■	■	2772.50	2861.95	2909.11	2998.56		

Storage Pantry — Wood Case with Laminate Front

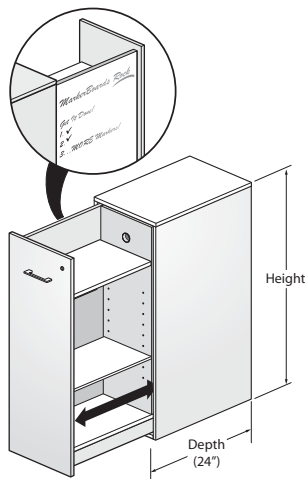
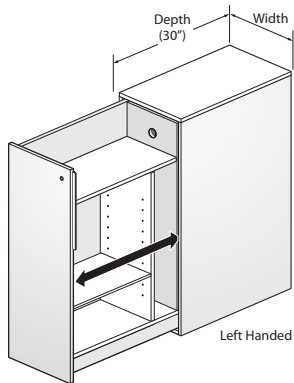

Features

- Includes: Wood case with laminate front sliding pull out storage pantry, glides and one center caster.
- Glides: Adjustment range: 0.78"(20mm).
- Center Caster: Height adjustable caster located in the center front of the pull out storage pantry. Adjustment range: 1"(25mm).
- Full extension slides.
- Storage pantry standard with fixed shelf between upper and lower storage compartments.
- Pantry drilled with holes in 2"(51mm) increments to accept separately specified adjustable shelf.
- Pantry interior standard in laminate.
- 15"(381mm) and 18"(457mm) wide units accommodate standard height binders in lower storage compartment.
- Optional USB Power Cutout Option comes with a precut hole to accept Bezel Utility Module. Bezel Utility Module is separately specified.
- Available with laminate or markerboard inner pantry side panel option. Inner pantry side panel is located on the non-user side of the pull-out pantry. Laminate option matches case interior laminate.
- Crescent, Linear and Classic pulls are brushed nickel finish. Blade pull available in trim color.
- Lock plug standard in chrome.
- Digital locks available. For this and other lock options, refer to Lock Program Price List.

Specification Tips

- 40"(1016mm) and 48"(1219mm) high pantry supports maximum load capacity of 180 pounds.
- 12"(305mm) wide units must be attached. (Refer to specification guidelines).
- 15"(381mm) and 18"(457mm) wide units can be freestanding.
- Extended depth pantry designed for back to back application to fill the gap on a bench or panel application.
- Separately specified and field installed options include:
 - Finished back
 - Bezel Utility Module (must be installed prior to installing a finished back)
 - Personal drawer
 - Hanging file drawer
 - Adjustable shelf
 - Upper and lower slat rails
- Personal or hanging file drawer allowed on 15"(381mm) or 18"(457mm) deep pantry. Field installed beneath fixed or adjustable shelf.
- Upper storage compartment is 6.38"(162mm) high.
- Lower Storage compartment height:
 - 40"(1016mm) high pantry - 27.98"(711mm) high
 - 48"(1219mm) high pantry - 35.98"(914mm) high
- Lower storage compartment of 24"(610mm) deep pantry consists of one storage section. 30"(762mm) deep pantry lower storage compartment comprised of one storage compartment and one valet with coat hook.
- User Orientation: If pantry is located on left-hand side of the user it is left-handed. If located on right-hand side of user it is right-hand.
- Refer to Specification Guide for planning information and actual dimensions.
- The following are recommended to maintain markerboard appearance:
 - Dry erase marker kit (includes holder, six markers and eraser), order part# 7062-8001.
 - Markerboard cleaner and conditioner, order part# 7031-7001.
 - Markerboard spray cleaner, order part# 7031-7002.

To Order, Specify:

- 1) Product number, including:

1 Inner Pantry Side Panel Option:

- Z** Laminate
- Y** Markerboard, add **\$40.00** list

2 Pull Option: (see side bar)

- Q** Blade Pull, add **\$40.00** list
- 7** Crescent Pull
- 8** Linear Pull
- 9** Classic Pull

3 User Orientation:

- L** Left-Hand
- R** Right-Hand

4 Lock Option:

- L** Locking, add **\$40.00** list
- N** Non-Locking

5 USB Power Cutout Option:

- N** No power cutout
- Y** Bezel Utility Module power cutout, add **\$50.00** list

- 2) Case exterior finish.
- 3) Interior laminate color.
- 4) Case interior edgeband color.
- 5) Front laminate color.
- 6) Front edgeband color.
- 7) Pull trim color (Blade pull only).

2 Pull Styles

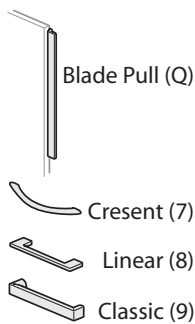

Storage Pantry — Wood Case with Laminate Front

Height	Depth	Width	Number ①	②	③	④	⑤	Case Wood Group A Front - Laminate		Case Wood Group B Front - Laminate		
								A	B	A	B	
Worksurface Depth												
40"(1016mm)	24"(610mm)	12"(305mm)	QLG1-4012-	WLL				\$2684.00	\$2710.87	\$2817.87	\$2844.74	
		15"(381mm)	QLG1-4015-	WLL				2741.00	2768.09	2877.54	2904.63	
		18"(457mm)	QLG1-4018-	WLL				2798.00	2825.09	2937.21	2964.30	
	30"(762mm)	12"(305mm)	QLM1-4012-	WLL				\$2900.00	\$2926.87	\$3050.97	\$3077.84	
		15"(381mm)	QLM1-4015-	WLL				2957.00	2984.09	3110.64	3137.73	
		18"(457mm)	QLM1-4018-	WLL				3014.00	3041.99	3170.31	3197.40	
	48"(1219mm)	24"(610mm)	12"(305mm)	QLG1-4812-	WLL				\$2852.00	\$2879.99	\$3000.11	\$3028.10
			15"(381mm)	QLG1-4815-	WLL				2909.00	2937.21	3059.78	3087.99
			18"(457mm)	QLG1-4818-	WLL				2966.00	2994.21	3119.45	3147.66
30"(762mm)		12"(305mm)	QLM1-4812-	WLL				\$3068.00	\$3095.99	\$3233.21	\$3261.20	
		15"(381mm)	QLM1-4815-	WLL				3125.00	3153.21	3292.88	3321.09	
		18"(457mm)	QLM1-4818-	WLL				3182.00	3210.21	3352.55	3380.76	
Extended Depth												
40"(1016mm)	25.5"(648mm)	12"(305mm)	QLG2-4012-	WLL				\$2711.00	\$2737.87	\$2844.87	\$2871.74	
		15"(381mm)	QLG2-4015-	WLL				2768.00	2795.09	2904.54	2931.63	
		18"(457mm)	QLG2-4018-	WLL				2825.00	2852.09	2964.21	2991.30	
	31.5"(800mm)	12"(305mm)	QLM2-4012-	WLL				\$2942.00	\$2968.87	\$3092.97	\$3119.84	
		15"(381mm)	QLM2-4015-	WLL				2999.00	3026.09	3152.64	3179.73	
		18"(457mm)	QLM2-4018-	WLL				3056.00	3083.09	3212.31	3239.40	
	48"(1219mm)	25.5"(648mm)	12"(305mm)	QLG2-4812-	WLL				\$2883.00	\$2910.99	\$3031.11	\$3059.10
			15"(381mm)	QLG2-4815-	WLL				2940.00	2968.21	3090.78	3118.99
			18"(457mm)	QLG2-4818-	WLL				2997.00	3025.21	3150.45	3178.66
31.5"(800mm)		12"(305mm)	QLM2-4812-	WLL				\$3114.00	\$3141.99	\$3279.21	\$3307.20	
		15"(381mm)	QLM2-4815-	WLL				3171.00	3199.21	3338.88	3367.09	
		18"(457mm)	QLM2-4818-	WLL				3228.00	3256.21	3398.55	3426.76	

Storage Pantry — Wood Case with Wood Front

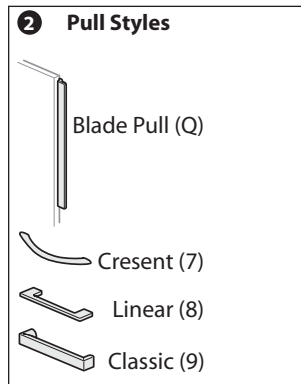
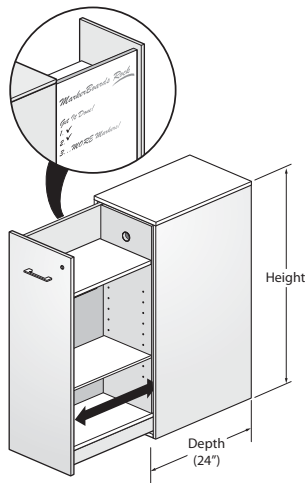
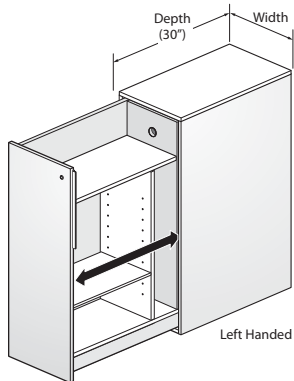

Features

- Includes: Wood case with wood front sliding pull out storage pantry, glides and one center caster.
- Glides: Adjustment range: 0.78"(20mm).
- Center Caster: Height adjustable caster located in the center front of the pull out storage pantry. Adjustment range: 1"(25mm).
- Full extension slides.
- Storage pantry standard with fixed shelf between upper and lower storage compartments.
- Pantry drilled with holes in 2"(51mm) increments to accept separately specified adjustable shelf.
- Pantry interior standard in laminate.
- 15"(381mm) and 18"(457mm) wide units accommodate standard height binders in lower storage compartment.
- Optional USB Power Cutout Option comes with a precut hole to accept Bezel Utility Module. Bezel Utility Module is separately specified.
- Available with laminate or markerboard inner pantry side panel option. Inner pantry side panel is located on back to non-user side of the pull-out pantry. Laminate option matches case interior laminate.
- Crescent, Linear and Classic pulls are brushed nickel finish. Blade pull available in trim color.
- Lock plug standard in chrome.
- Digital locks available. For this and other lock options, refer to Lock Program Price List.

Specification Tips

- 40"(1016mm) and 48"(1219mm) high pantry supports maximum load capacity of 180 pounds.
- 12"(305mm) wide units must be attached. (Refer to specification guidelines).
- 15"(381mm) and 18"(457mm) wide units can be freestanding.
- Extended depth pantry designed for back to back application to fill the gap on a bench or panel application.
- Separately specified and field installed options include:
 - Finished back
 - Bezel Utility Module (must be installed prior to installing a finished back)
 - Personal drawer
 - Hanging file drawer
 - Adjustable shelf
 - Upper and lower slat rails
- Personal or hanging file drawer allowed on 15"(381mm) or 18"(457mm) deep pantry. Field installed beneath fixed or adjustable shelf.
- Upper storage compartment is 6.38"(162mm) high.
- Lower Storage compartment height:
 - 40"(1016mm) high pantry - 27.98"(711mm) high
 - 48"(1219mm) high pantry - 35.98"(914mm) high
- Lower storage compartment of 24"(610mm) deep pantry consists of one storage section. 30"(762mm) deep pantry lower storage compartment comprised of one storage compartment and one valet with coat hook.
- User Orientation: If pantry is located on left-hand side of the user it is left-handed. If located on right-hand side of user it is right-hand
- Refer to Specification Guide for planning information and actual dimensions.
- The following are recommended to maintain markerboard appearance:
 - Dry erase marker kit (includes holder, six markers and eraser), order part# 7062-8001.
 - Markerboard cleaner and conditioner, order part# 7031-7001.
 - Markerboard spray cleaner, order part# 7031-7002.

To Order, Specify:

- 1) Product number, including:

1 Inner Pantry Side Panel Option:

- Z** Laminate
- Y** Markerboard, add **\$40.00** list

2 Pull Option: (see side bar)

- Q** Blade Pull, add **\$40.00** list
- 7** Crescent Pull
- 8** Linear Pull
- 9** Classic Pull

3 User Orientation:

- L** Left-Hand
- R** Right-Hand

4 Lock Option:

- L** Locking, add **\$40.00** list
- N** Non-Locking

5 USB Power Cutout Option:

- N** No power cutout
- Y** Bezel Utility Module power cutout, add **\$50.00** list

- 2) Case exterior wood finish.
- 3) Interior laminate color.
- 4) Case interior edgeband color.
- 5) Front wood finish.
- 6) Pull trim color (Blade pull only).

Storage Pantry — Wood Case with Wood Front

Height	Depth	Width	Number ①	②	③	④	⑤	Case Wood Group A		Case Wood Group B	
								Front - Wood Group A	Group B	Front - Wood Group A	Group B
Worksurface Depth											
40"(1016mm)	24"(610mm)	12"(305mm)	QLG1-4012-	WWL	■	■	■	\$3099.00	\$3172.87	\$3232.87	\$3306.74
		15"(381mm)	QLG1-4015-	WWL	■	■	■	3163.50	3238.71	3300.04	3375.25
		18"(457mm)	QLG1-4018-	WWL	■	■	■	3220.50	3295.71	3359.71	3434.92
	30"(762mm)	12"(305mm)	QLM1-4012-	WWL	■	■	■	\$3315.00	\$3388.87	\$3465.97	\$3539.84
		15"(381mm)	QLM1-4015-	WWL	■	■	■	3379.50	3454.71	3533.14	3608.35
		18"(457mm)	QLM1-4018-	WWL	■	■	■	3436.50	3511.71	3592.81	3668.02
	48"(1219mm)	24"(610mm)	12"(305mm)	QLG1-4812-	WWL	■	■	\$3347.00	\$3435.11	\$3495.11	\$3583.22
			15"(381mm)	QLG1-4815-	WWL	■	■	3411.50	3500.95	3562.28	3651.73
			18"(457mm)	QLG1-4818-	WWL	■	■	3468.50	3557.95	3621.95	3711.40
30"(762mm)		12"(305mm)	QLM1-4812-	WWL	■	■	\$3563.00	\$3651.11	\$3728.21	\$3816.32	
		15"(381mm)	QLM1-4815-	WWL	■	■	3627.50	3716.95	3795.38	3884.83	
		18"(457mm)	QLM1-4818-	WWL	■	■	3684.50	3773.95	3855.05	3944.50	
Extended Depth											
40"(1016mm)	25.5"(648mm)	12"(305mm)	QLG2-4012-	WWL	■	■	\$3126.00	\$3199.87	\$3259.87	\$3333.74	
		15"(381mm)	QLG2-4015-	WWL	■	■	3190.50	3265.71	3327.04	3402.25	
		18"(457mm)	QLG2-4018-	WWL	■	■	3247.50	3322.71	3386.71	3461.92	
	31.5"(800mm)	12"(305mm)	QLM2-4012-	WWL	■	■	\$3357.00	\$3430.87	\$3507.97	\$3581.84	
		15"(381mm)	QLM2-4015-	WWL	■	■	3421.50	3496.71	3575.14	3650.35	
		18"(457mm)	QLM2-4018-	WWL	■	■	3478.50	3553.71	3634.81	3710.02	
	48"(1219mm)	25.5"(648mm)	12"(305mm)	QLG2-4812-	WWL	■	■	\$3378.00	\$3466.11	\$3526.11	\$3614.22
			15"(381mm)	QLG2-4815-	WWL	■	■	3442.50	3531.95	3593.28	3682.73
			18"(457mm)	QLG2-4818-	WWL	■	■	3499.50	3588.95	3652.95	3742.40
31.5"(800mm)		12"(305mm)	QLM2-4812-	WWL	■	■	\$3609.00	\$3697.11	\$3774.21	\$3862.32	
		15"(381mm)	QLM2-4815-	WWL	■	■	3673.50	3762.95	3841.38	3930.83	
		18"(457mm)	QLM2-4818-	WWL	■	■	3730.50	3819.95	3901.05	3990.50	

Storage Pantry Finished Back

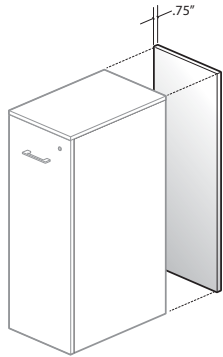

QALF

Height	Depth	Width	Number	Laminate	
				A	B
Laminate					
28"(711mm)	0.75"(19.05mm)	12"(305mm)	QALF-2812-L1	\$ 85.00	\$ 94.70
		15"(381mm)	QALF-2815-L1	94.00	104.42
		18"(457mm)	QALF-2818-L1	103.00	114.14
40"(1016mm)	12"(305mm)	12"(305mm)	QALF-4012-L1	\$115.00	\$127.10
		15"(381mm)	QALF-4015-L1	124.00	136.82
		18"(457mm)	QALF-4018-L1	133.00	146.54
48"(1219mm)	12"(305mm)	12"(305mm)	QALF-4812-L1	\$135.00	\$148.70
		15"(381mm)	QALF-4815-L1	144.00	158.42
		18"(457mm)	QALF-4818-L1	153.00	168.14
Height	Depth	Width	Number	Wood Group	
				A	B
Wood					
28"(711mm)	0.75"(19.05mm)	12"(305mm)	QALF-2812-W1	\$124.00	\$133.60
		15"(381mm)	QALF-2815-W1	137.50	149.50
		18"(457mm)	QALF-2818-W1	151.00	165.40
40"(1016mm)	12"(305mm)	12"(305mm)	QALF-4012-W1	\$172.00	\$190.12
		15"(381mm)	QALF-4015-W1	185.50	206.02
		18"(457mm)	QALF-4018-W1	199.00	221.92
48"(1219mm)	12"(305mm)	12"(305mm)	QALF-4812-W1	\$204.00	\$227.80
		15"(381mm)	QALF-4815-W1	217.50	243.70
		18"(457mm)	QALF-4818-W1	231.00	259.60

Features

- Includes: One field installed finished back and necessary hardware.
- Available in laminate or wood veneer.
- Pantry with finished back will accommodate a saddle.
- Finished back on 28"(711mm) high pantry allows use of spacer to attach to worksurface.

Specification Tips

- Once installed the finished back is not removable.
- Optional round Bezel Utility Module must be installed prior to installing the finished back.
- Finished back not required when pantry back is applied against a panel and not exposed.

To Order, Specify:

Laminate

- 1) Product number.
- 2) Laminate color.
- 3) Laminate edgeband color.

Wood

- 1) Product number.
- 2) Wood finish color.

Accessories

Pantry Accessories

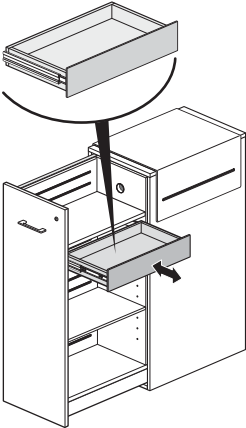
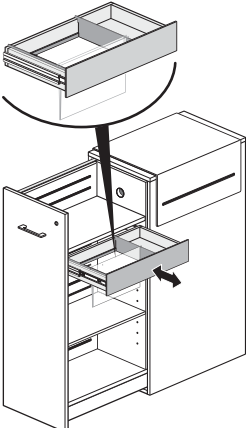
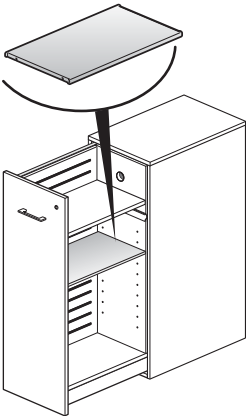
	Height	Depth	Width	Number	Trim A	Trim B
Personal Drawer  <p>QALD</p>	4"(102mm)	20"(508mm)	11 1/2"(292mm)	QALD-2415-S	\$225.00	\$230.00
Features <ul style="list-style-type: none"> Includes: One birchwood drawer frame with painted steel front, steel ball bearing drawer slides and hardware. Drawer to be field installed. Drawer is non-locking. 						
To Order, Specify: <ol style="list-style-type: none"> Product number. Drawer front trim color. 						
Specification Tips <ul style="list-style-type: none"> Compatible with Beside Pantry only. Limit 3 drawers allowed per pantry. Not for use on 12"(305mm) wide pantry. 						
Hanging File Drawer  <p>QALH</p>	4"(102mm)	20"(508mm)	11 1/2"(292mm)	QALH-2415-S	\$275.00	\$285.00
Features <ul style="list-style-type: none"> Includes: One birchwood drawer frame with painted steel front, steel ball bearing drawer slides and hardware. Drawer to be field installed. Letter size front to back filing. Drawer is non-locking. 						
To Order, Specify: <ol style="list-style-type: none"> Product number. Drawer front trim color. 						
Specification Tips <ul style="list-style-type: none"> Compatible with Beside Pantry only. Not for use on 12"(305mm) wide pantry. 						
Adjustable Shelf  <p>QALS</p>	.08"(20mm)	24"(610mm)	12"(305mm) 15"(381mm) 18"(457mm)	QALS-2412-S QALS-2415-S QALS-2418-S	\$107.00 110.75 114.50	\$124.00 129.25 134.50
Features <ul style="list-style-type: none"> Includes: Painted steel shelf and attachment hardware. Shelves adjust in 2"(51mm) increments. 30"(762mm) pantry with valet uses 24"(610mm) deep shelf. 						
To Order, Specify: <ol style="list-style-type: none"> Product number. Trim color. 						
Specification Tips <ul style="list-style-type: none"> To relocate shelves, use pliers to remove the four shelf studs. Can be used with or without the lower slat rail. Shelf will sit flush to the slat rail or flush to the back of the pantry. 						

Accessories

Pantry Accessories

	Height	Depth	Number	Trim A	Trim B
Upper Slat Rail	6"(152mm)	24"(610mm)	QALA-2406-S	\$ 92.00	\$ 99.00
		30"(762mm)	QALA-3006-S	104.00	114.00

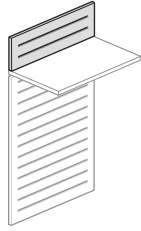

QALA

Features

- Includes: One painted steel slat rail and attachment hardware.
- Attaches above the fixed shelf inside Beside Pantry.

To Order, Specify:

- 1) Product number.
- 2) Trim color.

Specification Tip

- Compatible with Belong accessories. Tool cup must be used on bottom accessory rail. Hanging sorter cannot be used with Upper Slat Rail.

Lower Slat Rail

27.5"(699mm)	24"(610mm)	QALB-2440-S	\$262.00	\$294.50
35.5"(902mm)	24"(610mm)	QALB-2448-S	302.00	340.50



QALB

Features

- Includes: One painted steel slat rail and attachment hardware.
- Attaches below the fixed shelf inside Beside Pantry.

To Order, Specify:

- 1) Product number.
- 2) Trim color.

Specification Tips

- Compatible with Belong accessories.
- Not available on 28"(711mm) high pantry.

Saddle

Case Height	Depth	Width	Number	Trim A	Trim B
40"(1016mm)	24"(610mm)	12"(305mm)	QAGC-4012-SS	\$210.00	\$286.00
		15"(381mm)	QAGC-4015-SS	219.00	298.00
		18"(457mm)	QAGC-4018-SS	228.00	310.00
48"(1219mm)	24"(610mm)	12"(305mm)	QAGC-4812-SS	\$242.00	\$330.00
		15"(381mm)	QAGC-4815-SS	251.00	342.00
		18"(457mm)	QAGC-4818-SS	260.00	354.00
40"(1016mm)	30"(762mm)	12"(305mm)	QAMC-4012-SS	\$222.00	\$304.00
		15"(381mm)	QAMC-4015-SS	231.00	316.00
		18"(457mm)	QAMC-4018-SS	240.00	328.00
48"(1219mm)	30"(762mm)	12"(305mm)	QAMC-4812-SS	\$254.00	\$348.00
		15"(381mm)	QAMC-4815-SS	263.00	360.00
		18"(457mm)	QAMC-4818-SS	272.00	372.00

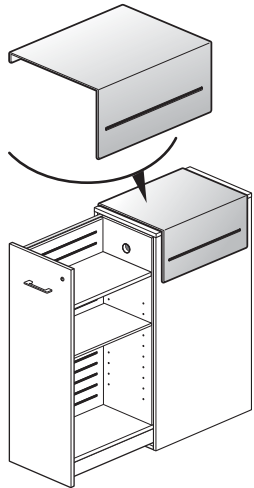

QAGC

Features

- Includes one painted steel saddle with accessory slot.
- Accessory slot accommodates Belong accessories.
- Saddle extends down over one side of the Beside Pantry.
- Saddle on 40"(1016mm) H Pantry extends down 9.5"(241mm). Saddle on 48"(1219mm) H Pantry extends down 17.5"(445mm).

To Order, Specify:

- 1) Product number.
- 2) Trim color.

Specification Tips

- For use on 40"(1016mm) or 48"(1219mm) high storage pantry only.
- Match width of saddle to width of storage pantry.

Attachment Brackets

Pantry Accessories

Product Application	Number	Trim A	B
Adaptable WS	ZUBW-0000-PN	\$23.63	N/A
Reside without legs/Adaptable Rectangular Convergent WS	ZUBT-0307-PN	31.51	N/A
Reside with legs	ZKBG-0000-PN	36.05	\$ 41.20
Intuity	ZBBG-0000-PN	39.14	44.29
Planes Height Adjustable Table-Bench	ZTBG-0000-PN	49.44	54.59

Features

- Includes: One steel non-handed bracket and hardware.
- For use with 40"(1016mm) and 48"(1219mm) H Pantry.

To Order, Specify:

- 1) Product number.
- 2) Trim color (if applicable).

Specification Tips

- Two ZUBW-0000-PN brackets (standard in Black) are used to attach one end of an Adaptable Worksurface in an off modular worksurface condition in a Compose panel application. The back of the off-modular worksurface must also be attached to the panel with a worksurface support bracket.
- Two ZUBT-0307-PN brackets (standard in Black) are used in the following conditions:
 - To attach one end of an Adaptable rectangular convergent worksurface with a maximum width of 60"(1524mm) in a non-panel based application. Opposite end requires a floor support option or to be attached to another storage pantry.
 - In place of Reside support legs to attach one end of a Reside worksurface to a storage pantry.
 - When passing power through storage pantry or pantries to another Reside worksurface.
- Two ZKBG-0000-PN brackets are used to attach one end of an Reside Worksurface in conjunction with Reside support legs adjacent to the storage pantry in the following conditions:
 - When passing power through storage pantry or pantries to another Reside worksurface.
 - To support a 12"(305mm) wide storage pantry if field supplied ganging hardware is not applicable.
- Two ZBBG-0000-PN brackets are used to attach one end of an Intuity Worksurface in conjunction with Intuity support legs adjacent to the storage pantry in the following conditions:
 - When passing power through storage pantry or pantries to another Intuity worksurface.
 - To support a 12"(305mm) wide storage pantry if field supplied ganging hardware is not applicable.
- Two ZTBG-0000-PN brackets are used to attach one end of an Planes Height Adjustable Table - Bench worksurface in the following conditions:
 - When passing power through storage pantry or pantries to another Planes Height Adjustable Table - Bench worksurface.
 - To support a 12"(305mm) wide storage pantry if field supplied ganging hardware is not applicable.
- Jumper and Grommets are separately specified for routing power from desk-to-desk through a pantry or pantries.
- Refer to specification guide for planning information.

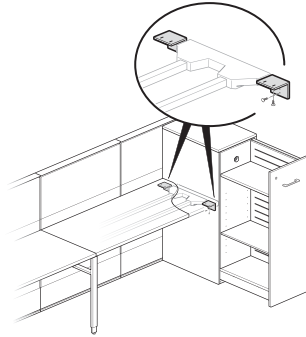

ZUBW-0000-PN

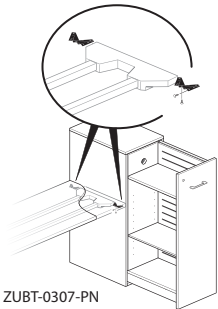

ZUBT-0307-PN

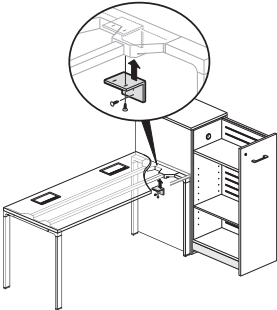

ZKBG-0000-PN

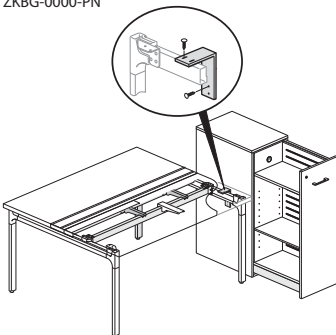

ZBBG-0000-PN

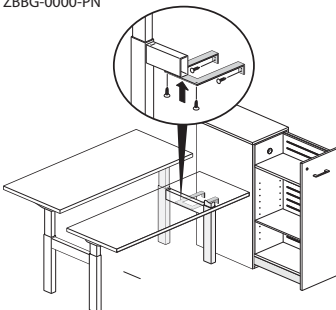

ZTBG-0000-PN

Attachment Brackets

Pantry Accessories

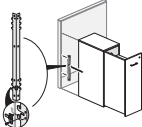
	Product Application	Number	Trim A	B
Compose Panel to Pantry Bracket	Compose Panel, Anti-Dislodgement Bracket, X Series 2H Storage & Beside Pantry	ZZBF-1800-PNW	\$94.54	\$108.20
	<p>Features</p> <ul style="list-style-type: none"> • Includes: One painted steel non-handed panel to pantry bracket. • Used to attached Compose Full Panel Frame to Beside Pantry. • For use with panels equal or taller than Beside Pantry. • Installs in panel frame slots and attaches to the back corner. <p>Specification Tips</p> <ul style="list-style-type: none"> • Installation requires drilling of Pantry. • Not for use with finished back. 	<p>To Order, Specify:</p> <p>1) Product number.</p>		

ZZBF-1800-PNW

Electrical Components

Bezel Utility Model

Description	Diameter	Number	①	Price
12' Cord	1.75"(44mm)	EURT-00E4-1010C	■	\$273.11

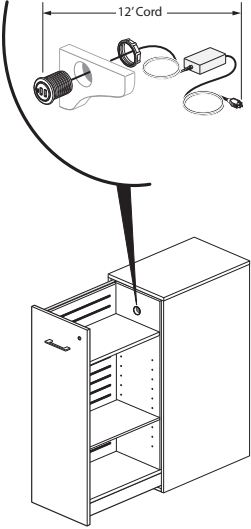

EURT-0072-1010



Features

- Includes: Round faced Power Module and mounting hardware.
- For use on surfaces 0.75"(19mm) - 2.0"(51mm) thick.
- Available with: One two port USB charger. Consists of two USB outlets with 1000mA of charging power (5 volts) per USB outlet.
- Available in black or supplier white only.

Specification Tips

- For use with 120 volt 60 hertz power source only.
- Unit has one cord with 2"(51mm)x 1"(25mm) x 3"(76mm) voltage transformer plug. Transformer may block adjacent outlets.
- Field installed.
- Application may require approval of local authority having jurisdiction (AHJ); ensure compliance before placing orders and installing.

To Order, Specify:

1) Product number, including:



① Color Options:

B Black

W White

Electrical Components

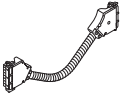
Pantry Accessories

	Description	Actual Length	Number	Price
Jumpers  EUEJ-0036-2 SIN 711-2; Discount Group XIII 	3-Circuit			
		36"(914mm)	EUEJ-0036-3	\$118.14
		42"(1067mm)	EUEJ-0042-3	124.95
		48"(1219mm)	EUEJ-0048-3	131.76
		54"(1372mm)	EUEJ-0054-3	138.57
		60"(1524mm)	EUEJ-0060-3	145.38
	4-Circuit, 2+2			
		36"(914mm)	EUEJ-0036-2	\$124.96
		42"(1067mm)	EUEJ-0042-2	131.77
		48"(1219mm)	EUEJ-0048-2	138.58
		54"(1372mm)	EUEJ-0054-2	145.39
		60"(1524mm)	EUEJ-0060-2	152.20
	4-Circuit, 3+1			
		36"(914mm)	EUEJ-0036-4	\$124.96
		42"(1067mm)	EUEJ-0042-4	131.77
	48"(1219mm)	EUEJ-0048-4	138.58	
	54"(1372mm)	EUEJ-0054-4	145.39	
	60"(1524mm)	EUEJ-0060-4	152.20	

Features

- Includes flexible metal power jumper with safety latches.
- For use with power components.
- Jumpers cannot be coupled together.
- Field installed.

To Order, Specify:

- 1) Product number.
(No finish specification required.)

Specification Tips

- Jumper routes power from desk/bench through a storage pantry or two side-by-side storage pantries to another desk/bench.
- For use with the following powered desk/bench applications:
 - Reside
 - Intuity
 - Planes Height Adjustable Table - Bench
- Not for use with Planes Height Adjustable Tables.
- Each jumper requires (2) separately specified grommets (KUAG-0204-PA); one for the exposed entry site and one for the exposed exit site.
- Refer to Specification Guide for calculation of jumper length.
- Do not mix 3-circuit with 4-circuit components. Do not mix 2+2 and 3+1 components.
- Components have unique polarity key and color coding (3-circuit = black; 2+2 = blue; 3+1 = green).

Grommet	Height	Depth	Width	Number	Price
	4"(102mm)	11/16"(17mm)	2"(51mm)	KUAG-0204-PA	\$21.01

Features

- Includes one grommet.
- Standard in black.
- Installed in field drilled hole.

To Order, Specify:

- 1) Product number.
(No finish specification required.)

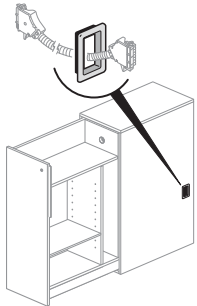

KUAG

SIN 711-3;
Discount Group XIII

Specification Guide Beside Storage

Table of Contents – Beside Storage

Statement of Line – Beside Storage

Statement of Line 157

Product Details – Beside Storage

Wood Grain Direction 166

Base Units

Functional Configuration Options 167
Components 168
Widths and Functional Sections 169
Finished Heights 170
Depth 171
Spacer Dimensions 172
Interior / Exterior Dimensions 173-183
Drawer Capacity and Load 184
Surface Materials and Finishes 185
Order For Specifying Base Unit Colors 186

Storage Tops 187

Finished Backs and Filler Panels 188

Accessory Shelf 189

Brackets

Storage-To-Panel Bracket 190
Desk To Storage Bracket 190
Storage Attachment Bracket 191
Flush Mount Plate 191
Ganging Bracket Kit 191

Electrical Components

Infeed Harness 192
Internal Power Base AI Base Feed 192
Base Feed Module: Architectural Concealed Hardwire Connection 193
Top Feed 194
Power Distribution Assembly (PDA) 195
Jumper – Power Connectors 195
Jumper Application Guidelines 196
Calculating Jumper Lengths 198
Power Taps 199
Power Tap Brackets 199
Power Tap Application Guidelines 200
Calculating Power Tap Reach 201
Typical Conduit Routing for Beside Storage 202

Stanchion Kits

Configurations 203
Application Guidelines 204
Specifying Accessory Slot Functionality 205
Accessory Slot Dimensions 206-213
Designing with Stanchion Kits – Orientation Options 214
Specification Sequence For Stanchion Kit Paint Color 215

Hutch Shelf 216

Overhead Storage Units – Dimensions 217-223

Table of Contents – Beside Storage

Product Details – Beside Storage (continued)

storage Pantry	
28" High/24" Deep	224
28" High/30" Deep	225
40" High/24" Deep	226
40" High/30" Deep	227
48" High/24" Deep	228
48" High/30" Deep	229
Finished Backs	230
Personal Drawer	231
Hanging File Drawer.....	232
Adjustable Shelf	233
Upper Slat Rail	234
Lower Slat Rail	235
Saddle.....	236
Brackets	327-328
Bezel Utility Module	239
Grommet	240
Digital Locks	241
Pull Options	242-243
Wood Grain Direction	244

Product Application – Beside Storage

Storage Attachment Guidelines

Planning Model Overview	246-247
In-Line and Back-To-Back Storage Planning Models – Ganging Bracket Kit	248
Ganging Bracket Kit Application Guidelines	249
Desk-to-Storage Bracket / Storage Attachment Bracket.....	250
Flush Mount Plate.....	251
Panel Systems and Base Units.....	252

Storage Based Planning With Attached Perpendicular Worksurface

Application Guidelines	253
Desk-To-Storage Bracket Application Guidelines	254
Flush-Mount Plate Application Guidelines	257
Mixed Type A and Type B Base Unit Applications	258
Application Guidelines For Type A Base Units	260
Application Guidelines For Mixed Type A and Type B Base Units	261
Worksurface Interference with Base Unit Drawers / Hinged Doors.....	262
Screen Interference with Base Unit Drawers	263
Application Overview – Storage Based Planning with Single Sided Rectilinear Benching.....	264
Application Overview – Storage Based Planning with Double Sided Rectilinear Benching.....	95
Application Overview – Storage Based Desking Cluster With Single Depth Storage Spine	96
Application Overview – Storage Based Desking Cluster With Double Depth Storage Spine	267
Stanchion Kits – Vertical Planning Models	268
Stanchion Kits – Hutch Applications	269
Stanchion Kits – Stanchion Mounted Overhead Storage Unit Applications	270
Six Easy Steps – Designing A Hutch Application	271
Six Easy Steps –Designing A Stanchion Kit Mounted Overhead Storage Unit Application.....	272

Table of Contents – Beside Storage

Product Application – Beside Storage (continued)

- Storage Based Planning – One-High Hutch Applications 273
- Storage Based Planning – Two-High Hutch Applications 279
- Storage Based Planning – Back-To-Back Base Units Hutch Applications 284
- Application Guidelines – Panel Mounted Overhead Storage Unit (OSU) 285
- Application Overview – Storage Based Desking Cluster With Single Depth Storage Spine 286
- Critical Dimensions for Planning - Hutch Application 287
- Critical Dimensions for Planning – Beside Storage Hutch with Compose Panels..... 288
- Storage Pantry – Product Platform Compatibility Overview 289
- Storage Pantry – Product Planning Introduction..... 290
- Planning Model Overview – Storage Pantry (28” High – Worksurface Depth) 291
- Planning Model Overview – Storage Pantry – 40” and 48” High/Worksurface Depth292-295
- Storage Pantry / Non-Panel Based – Freestanding Applications.....26-299
- Storage Pantry / Compose Panel Applications300-309
- Storage Pantry / Reside Benching Applications310-317
- Storage Pantry / Intuity Benching Applications318-323
- Storage Pantry / Planes Height Adjustable Table Bench Applications324-326

Technical Specifications – Beside Storage

- Technical Specifications.....327-331

Statement of Line Beside Storage

Statement of Line – Beside Storage

Base Unit – Open Storage

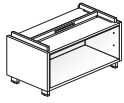

Single Width
One-High
QBSO-17__-ZNNNN_N

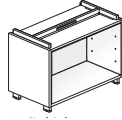

Single Width
One and One-Half High
QBSO-23__-ZNNNN_N

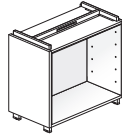

Single Width
Two-High
QBSO-29__-ZNNNN_N

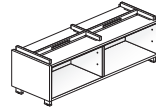

Double Width
One-High
QBDO-17__-ZZNNN_N

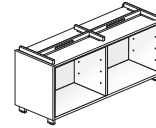

Double Width
One and One-Half High
QBDO-23__-ZZNNN_N

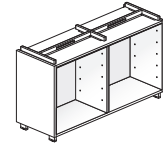

Double Width
Two-High
QBDO-29__-ZZNNN_N

Base Unit – Open Storage with Drawer

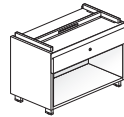

Single Width
One and One-Half High
QBSF-23__-CNN

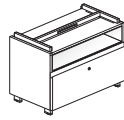

Single Width
One and One-Half High
QBSF-23__-DNN



Single Width
Two-High
QBSF-29__-CNN



Single Width
Two-High
QBSF-29__-DNN

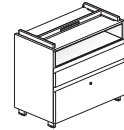

Single Width
Two-High
QBSF-29__-FNN

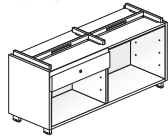

Double Width
One and One-Half High
QBDF-23__-CZN
QBDF-23__-ZCN

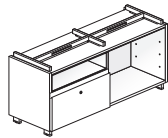

Double Width
One and One-Half High
QBDF-23__-DZN
QBDF-23__-ZDN

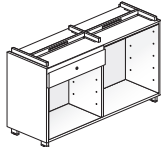

Double Width
Two-High
QBDF-29__-CZN
QBDF-29__-ZCN

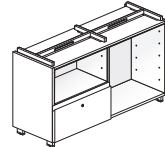

Double Width
Two-High
QBDF-29__-DZN
QBDF-29__-ZDN

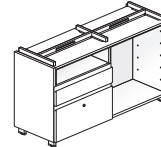

Double Width
Two-High
QBDF-29__-FZN
QBDF-29__-ZFN

Base Unit – Drawer Combinations

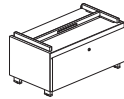

Single Width
One-High
QBSF-17__-ANN

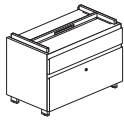

Single Width
One and One-Half High
QBSF-23__-BNN

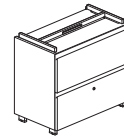

Single Width
Two-High
QBSF-29__-ENN

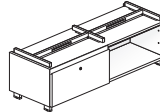

Double Width
One-High
QBDF-17__-AZN
QBDF-17__-ZAN

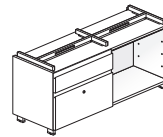

Double Width
One and One-Half High
QBDF-23__-BZN
QBDF-23__-ZBN

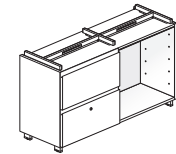

Double Width
Two-High
QBDF-29__-EZN
QBDF-29__-ZEN

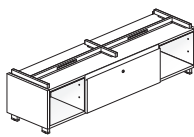

Triple Width
One High
QBTF-17__-ZAZ

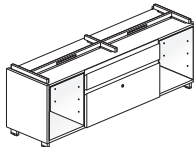

Triple Width
One and One-Half High
QBTF-23__-ZBZ

Statement of Line – Beside Storage

Base Unit – Hinged Door

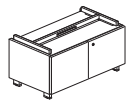

Single Width
One-High
QBSF-17__-GNN

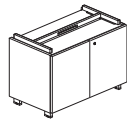

Single Width
One and One-Half High
QBSF-23__-HNN

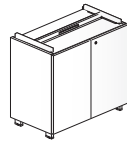

Single Width
Two-High
QBSF-29__-JNN

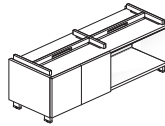

Double Width
One-High
QBDF-17__-GZN
QBDF-17__-ZGN

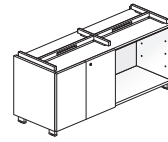

Double Width
One and One-Half High
QBDF-23__-HZN
QBDF-23__-ZHN

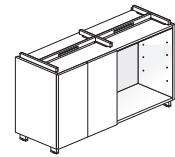

Double Width
Two-High
QBDF-29__-JZN
QBDF-29__-ZJN

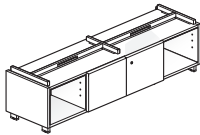

Triple Width
One-High
QBTF-17__-ZGZ

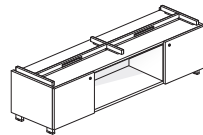

Triple Width
One-High
QBTF-17__-ZGZ

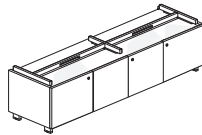

Triple Width
One-High
QBTF-17__-GGG

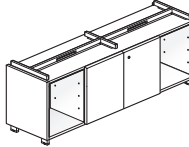

Triple Width
One and One-Half High
QBTF-23__-ZHZ

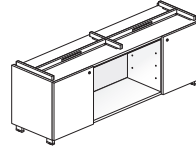

Triple Width
One and One-Half High
QBTF-23__-HZH

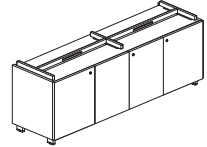

Triple Width
One and One-Half High
QBTF-23__-HHH

Base Unit – Hinged Door and Open Storage

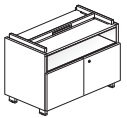

Single Width
One and One-Half High
QBSF-23__-KNN

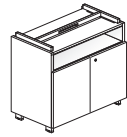

Single Width
Two-High
QBSF-29__-LNN

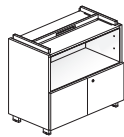

Single Width
Two-High
QBSF-29__-KNN

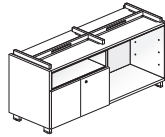

Double Width
One and One-Half High
QBDF-23__-KZN
QBDF-23__-ZKN

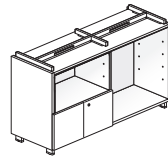

Double Width
Two-High
QBDF-29__-KZN
QBDF-29__-ZKN

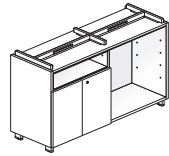

Double Width
Two-High
QBDF-29__-LZN
QBDF-29__-ZLN

Base Unit – Hinged Door and Drawer Combination

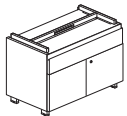

Single Width
One and One-Half High
QBSF-23__-MNN

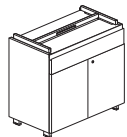

Single Width
One and One-Half High
QBSF-29__-ONN

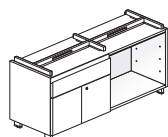

Double Width
One and One-Half High
QBDF-23__-MZN
QBDF-23__-ZMN

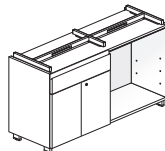

Double Width
One and One-Half High
QBDF-29__-OZN
QBDF-29__-ZON

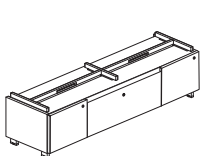

Triple Width
One-High
QBTF-17__-GAG

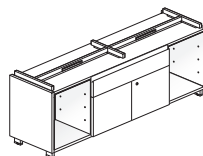

Triple Width
One and One-Half High
QBTF-23__-ZMZ

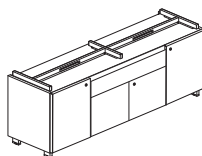

Triple Width
One and One-Half High
QBTF-23__-HMH

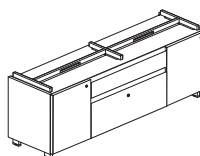

Triple Width
One and One-Half High
QBTF-23__-HBH

Statement of Line – Beside Storage

Base Unit – Single Sliding Door

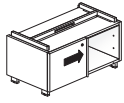

Single Width
One-High
QBDF-17__-SZN
QBDF-17__-ZTN

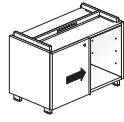

Single Width
One and One-Half High
QBDF-23__-SZN
QBDF-23__-ZTN

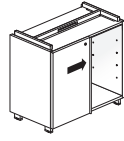

Single Width
Two-High
QBDF-29__-SZN
QBDF-29__-ZTN

Base Unit – Double Sliding Door

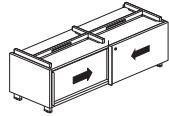

Double Width
One High
QBDF-17__-QNN
QBDF-17__-PNN

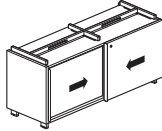

Double Width
One and One-Half High
QBDF-23__-QNN
QBDF-23__-PNN

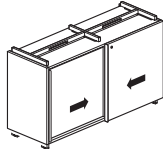

Double Width
Two High
QBDF-29__-QNN
QBDF-29__-PNN

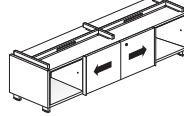

Triple Width
One High
QBTF-17__-ZRZ

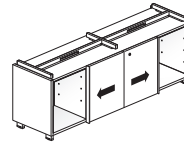

Triple Width
One and One-Half High
QBTF-23XX-ZRZ

Storage Tops



Storage Top
(Single Width Base Unit)
QBRA-18__

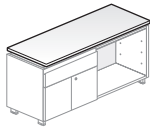

Storage Top
(Double Width Base Unit)
QBRA-18__

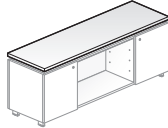

Storage Top
(Triple Width Base Unit)
QBRA-18__

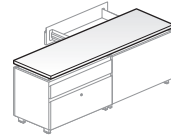

Storage Top
(Spanning Top - more
than one Base Unit)
QBRA-18__

Finished Back

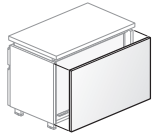

Finished Back
QBBK

Accessories – Base Unit Accessory Shelf

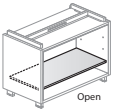

Base Unit Accessory Shelf
Single Units – Open
QASS-__-BNS

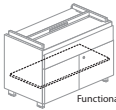

Base Unit Accessory Shelf
Single Units – Functional
QASS-__-BNS

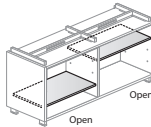

Base Unit Accessory Shelf
Double Units –
Open/Open
QASD-__-ONS

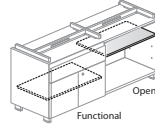

Base Unit Accessory Shelf
Double Units –
Open/Functional
QASD-__-BNS (Functional)
QASS-__-XNS (Open Side)

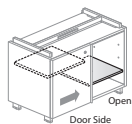

Base Unit Accessory Shelf
Single Sliding Door
QASD-__-FNS
(Door Side 24"-42")
QASS-__-BNS
(Door Side 48"-72")
QASD-__-XNS
(Open Side 24"-72")

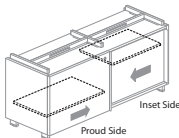

Base Unit Accessory Shelf
Double Sliding Door
QASP-__-FNS
(Proud Side 24"-72")
QASR-__-FNS
(Inset Side 24"-72")

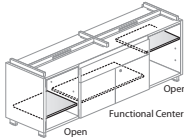

Base Unit Accessory Shelf
Center Slider – Triple Unit
QASS-__-BNS (Center)
QAST-__-FFS
(Wings - Open or Hinged)

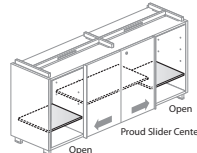

Functional or Proud

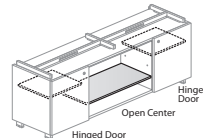

Base Unit Accessory Shelf
Open Center – Triple Unit
QAST-__-XNS (Center)
QAST-__-FOS
(Wings - Hinged Door)

Statement of Line – Beside Storage

Accessories

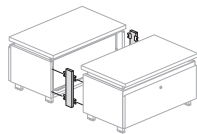

Filler Panel – One-High
QAFF-0017-AL (1.5" Gap)
QAFF-0017-BL (2.8" Gap)
QAFF-0017-CL (5.1" Gap)

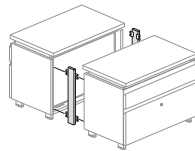

Filler Panel – One and One-Half High
QAFF-0023-AL (1.5" Gap)
QAFF-0023-BL (2.8" Gap)
QAFF-0023-CL (5.1" Gap)

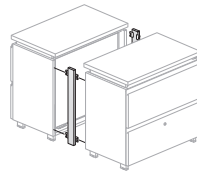

Filler Panel – Two-High
QAFF-0029-AL (1.5" Gap)
QAFF-0029-BL (2.8" Gap)
QAFF-0029-CL (5.1" Gap)

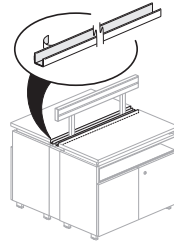

Top Filler Track
9060-8803

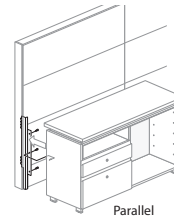

Storage to Panel Bracket – Parallel
ZEBQ (UniGroup Too)
ZZBQ (Compose)
ZNBQ (PREMISE)

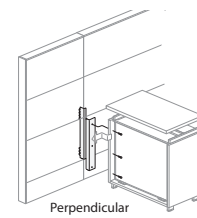

Storage to Panel Bracket – Perpendicular
ZEBQ (UniGroup Too)
ZZBQ (Compose)
ZNBQ (PREMISE)

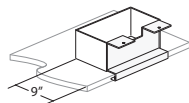

Desk-to-Storage Bracket – Half Cover
ZUBG-29__-PNHC

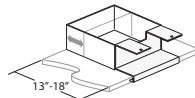

Desk-to-Storage Bracket – Full Cover
ZUBG-29__-PNFC

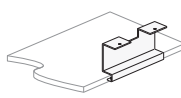

Storage Attachment Bracket
ZUBG-2900-PNHN

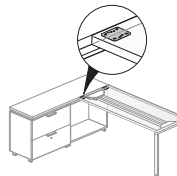

Flush Mount Plate
ZUBF-0000-PN

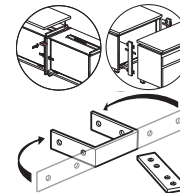

Ganging Bracket Kit
QAGB-0000

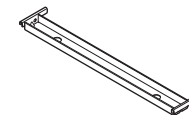

Front-to-Back Hanging Bar
SFCK-0013

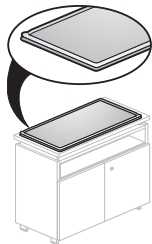

Cushion
QBFC_F

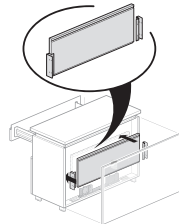

Counterweight
2670

Electrical Components

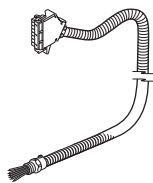

Infeed Harness
EUEH

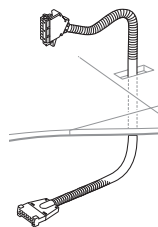

Internal Power Base™ AI
Base Feed
EUEJ

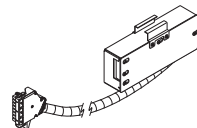

Base Feed Module – Architectural Concealed – Hardwire Connection
EUEB-0000-3HY



Top Feed – Beside Storage Only
EQET-__ 00-3

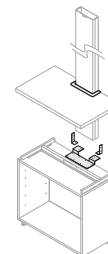

Top Feed Grommet – Beside Storage Only
EQAG-0000-PT

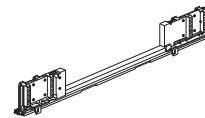

Power Distribution Assembly – Beside Storage Only
EUEP-00__-3Q

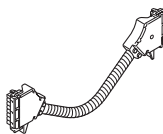

Jumpers
EUEJ-00__-3

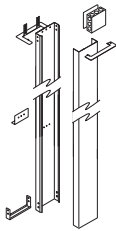

Top Feed – Hardwire Beside Storage Only
EQET-__ 00-C

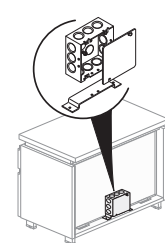

Hardwire Kit – Beside Storage Only
EQEP-0000-C

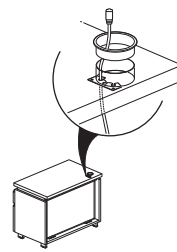

Patch Cord Data Holder Bracket
EUAD-0000-GD

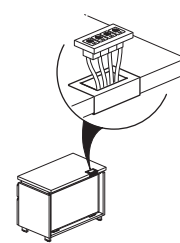

Modular Furniture Telecommunication Opening – Top Mount
EUDZ-0000-WD

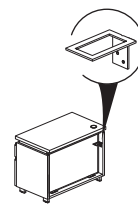

Modular Furniture Telecommunication Opening – Sidewall Mount
EUDZ-0000-QD

Statement of Line – Beside Storage

Stanchions Kits

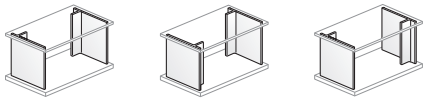

Stanchion Kit – G
QUSS-____-G_N

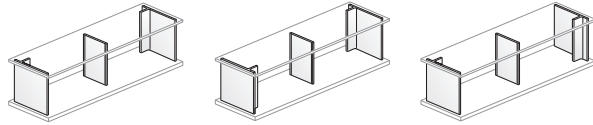

Stanchion Kit – H
QUSS-____-H_N

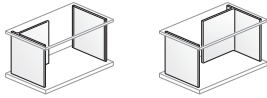

Stanchion Kit – M
QUSS-____-M_

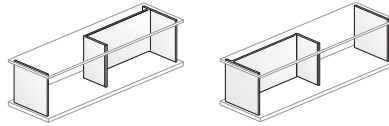

Stanchion Kit – N
QUSS-____-N_

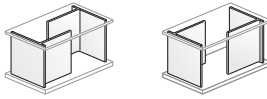

Stanchion Kit – P
QUSS-____-P_

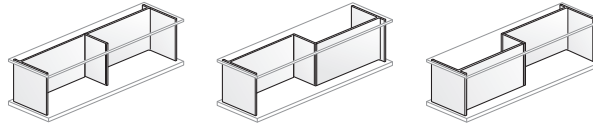

Stanchion Kit – Q
QUSS-____-Q_

Hutch Shelf

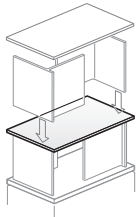

Hutch Shelf
QUHT-____-

Overhead Storage Unit



Single Sided Open –
Single Width
QUS1-16__-H_NNN

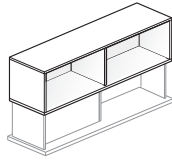

Single Sided Open –
Double Width
QUS1-16__-H_NNN

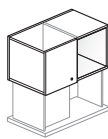

Single Sided Full Hinged
Single Door/Open –
(24"-42" Wide)
QUS1-16__-A__N_
(Open Left)
QUS1-16__-B__N_
(Open Right)

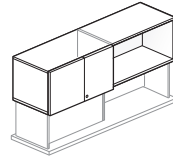

Single Sided Full Hinged
Doors/Open –
(48"-72" Wide)
QUS1-16__-A__N_
(Open Left)
QUS1-16__-B__N_
(Open Right)

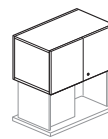

Single Sided Full Hinged
Doors – Single Width
(24"-42" Wide)
QUS1-16__-C__N_

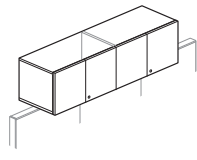

Single Sided Full Hinged
Doors – Double Width
(48"-72" Wide)
QUS1-16__-C__N_

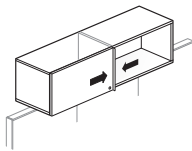

Single Sided
Single Sliding Door
– Right
QUS1-16__-D__V_
– Left
QUS1-16__-E__V_

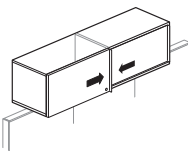

Single Sided
Double Sliding Doors
– Right
QUS1-16__-F__V_
– Left
QUS1-16__-G__V_

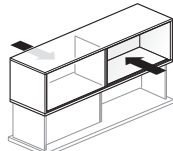

Dual Sided Open
– Right
QUS2-16__-J_NNN
– Left
QUS2-16__-K_NNN

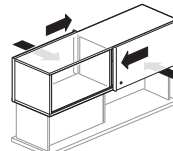

Dual Sided Sliding Doors
– Right
QUS2-16__-D__V_
– Left
QUS2-16__-E__V_

Statement of Line – Beside Storage

Overhead Storage Unit Accessories

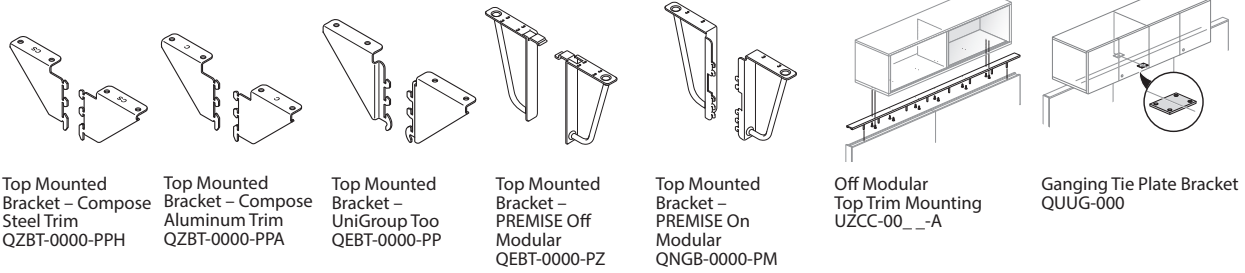

Lighting

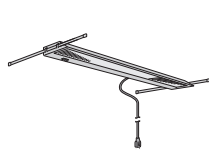

Adaptable Electronic Ballast Task Light
LUTS-00__ - 16UEP

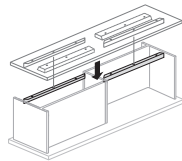

Adaptable Light Skirt
QULS-00__

Belong Screens

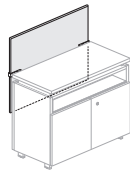

Screen – Back
SUFB-____-__U

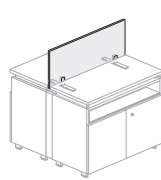

Screen – Center
SUPC-____-__U

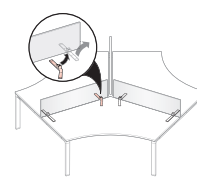

Bracket – Screen – For use with 120° Reside worksurface
SUCB-0000

Storage Pantry

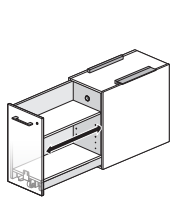

Storage Pantry
28" High
QLG1
QLM1

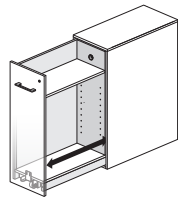

Storage Pantry
40" High
QLG1
QLM1
QLG2
QLM2

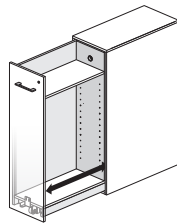

Storage Pantry
48" High
QLG1
QLM1
QLG2
QLM2

Storage Pantry Finished Backs

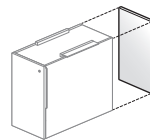

Finished Back
28" High
QALF

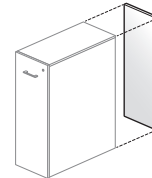

Finished Back
40" High
QALF

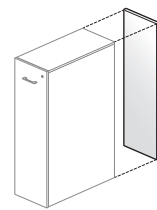

Finished Back
48" High
QALF

Storage Pantry Accessories

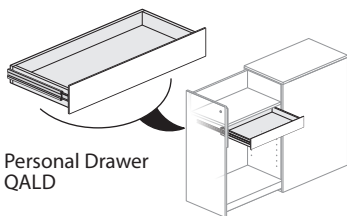

Personal Drawer
QALD

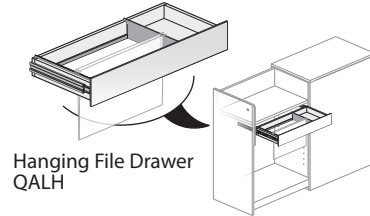

Hanging File Drawer
QALH

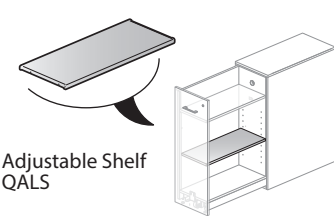

Adjustable Shelf
QALS

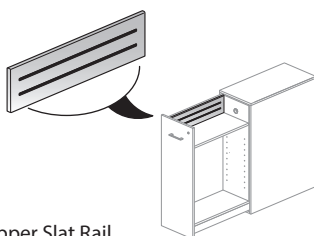

Upper Slat Rail
QALA

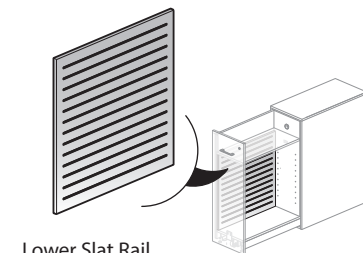

Lower Slat Rail
QALB

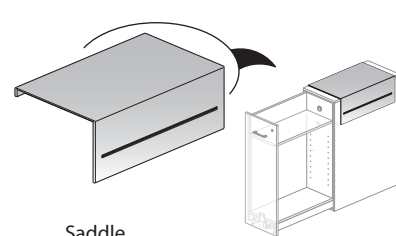

Saddle
QAGC

Statement of Line – Beside Storage

Beside Storage Pantry Brackets

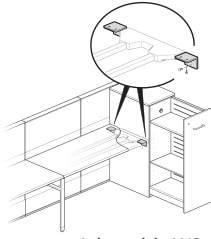

Adaptable WS Bracket

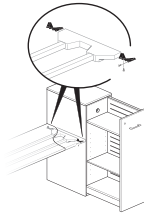

Reside without legs/
Adaptable Rectangular
Convergent WS Bracket

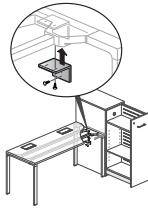

Reside with
legs Bracket

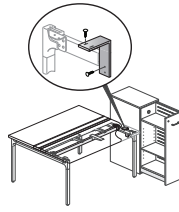

Intuity
Bracket

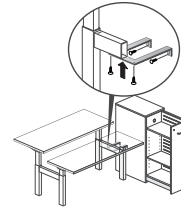

Planes Height
Adjustable
Table-Bench
Bracket

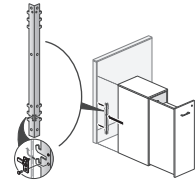

Compose Panel to
Panty Bracket

Power Components

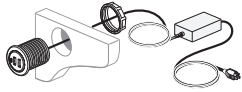

Bezel Utility
Module – 12' Cord

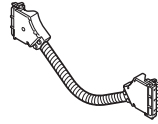

Jumper – 3 or 4 Circuit

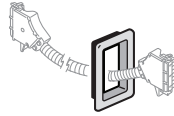

Grommet

Product Details Beside Storage

Product Details – Beside Storage

Wood Grain Direction

Natural Veneer

Vertical Surfaces – Wood grain runs vertically on drawers, hinged doors, sliding doors and finished backs.

Horizontal Surfaces – Wood grain runs side-to-side on storage tops.

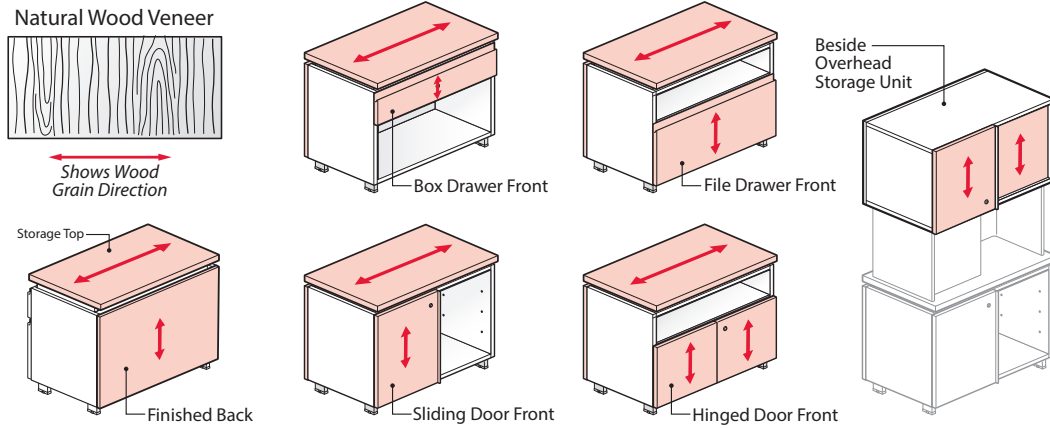

Double Cut Veneer

Vertical Surfaces – Wood grain runs horizontally on drawers, hinged doors, sliding doors and finished backs.

Horizontal Surfaces – Wood grain runs side-to-side on storage tops.

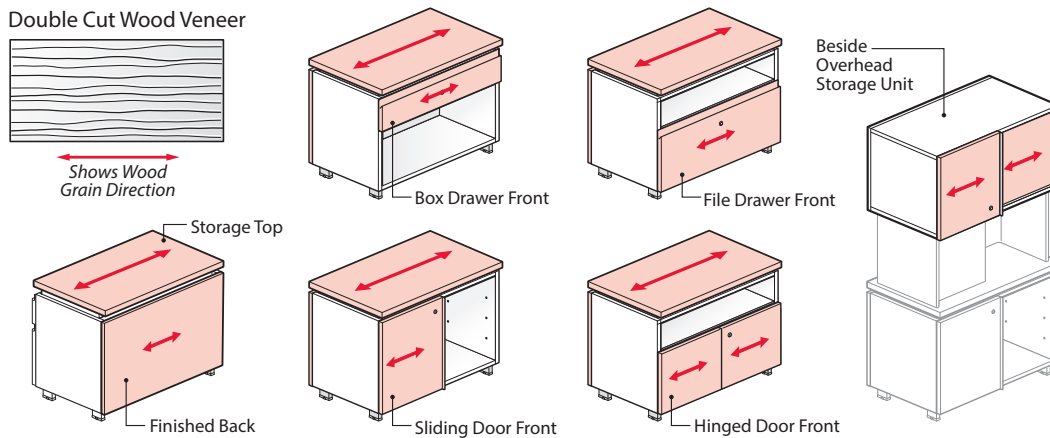

Note Surfaces without arrows are a laminate finish or painted steel finish.

Wood Grain Laminate

Vertical Surfaces – Wood grain runs vertically on drawers, hinged/sliding doors, end panels and finished backs.

Horizontal Surfaces – Wood grain runs side-to-side on tops and storage tops.

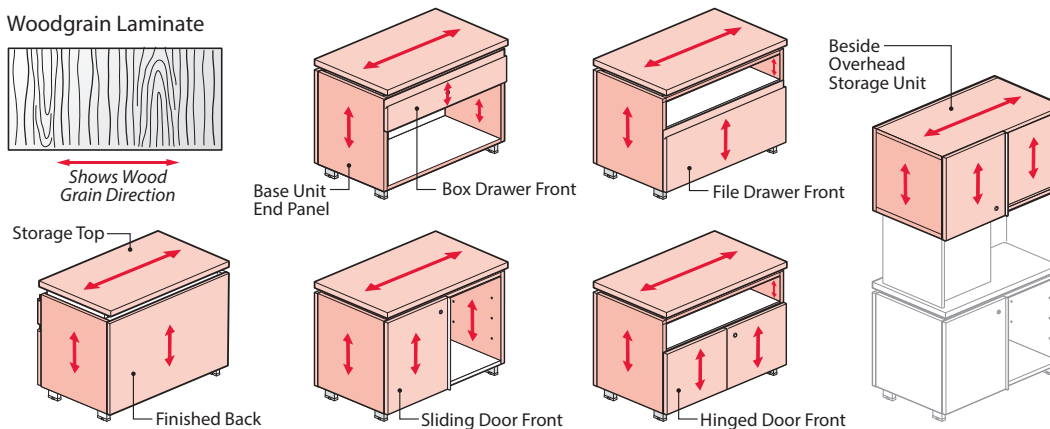

Note Surfaces without arrows are a painted steel finish.

Product Details – Beside Storage

Base Units – Functional Configuration Options

Open Storage

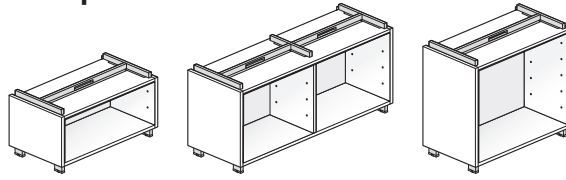

Open Storage With Drawer

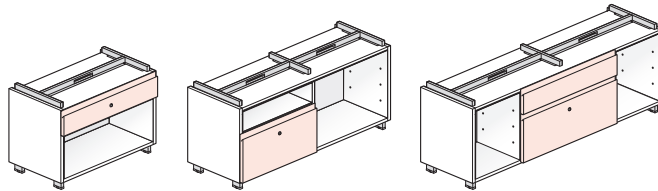

Drawer Combinations

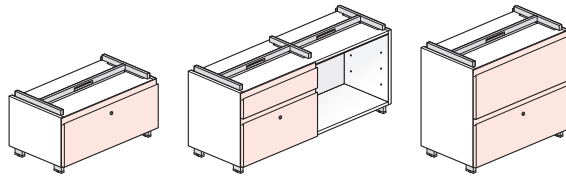

Single Sliding Door

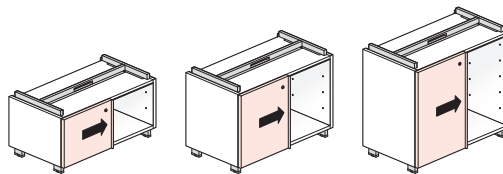

Hinged Door

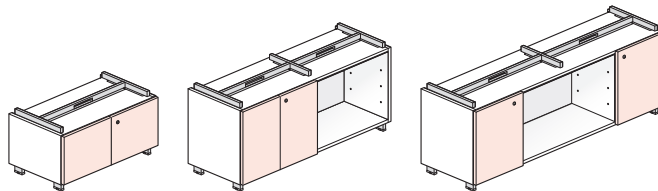

Hinged Door With Open Storage

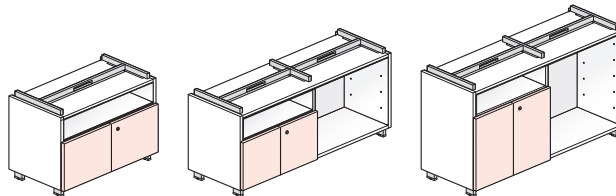

Hinged Door With Drawer Combination

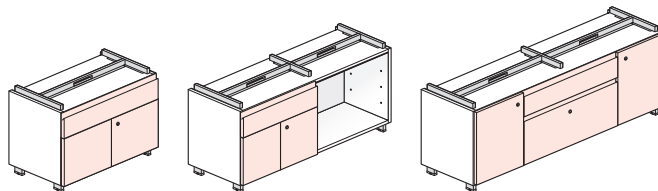

Double Sliding Door

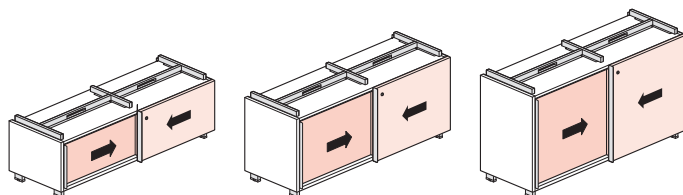

Note For all available height, width and functional configurations refer to the price list for product offerings.

Product Details – Beside Storage

Base Units – Components

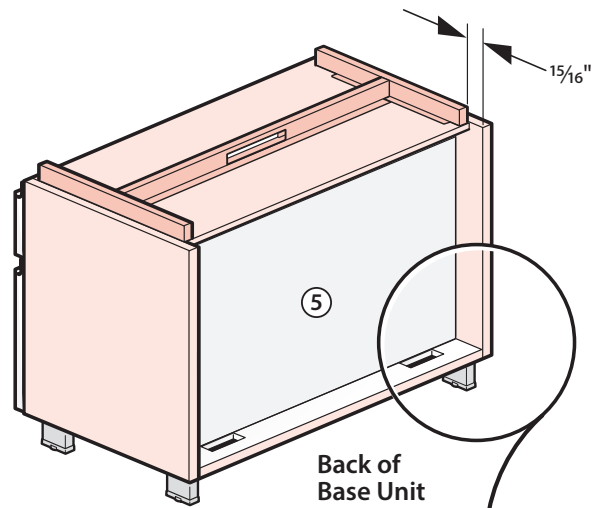
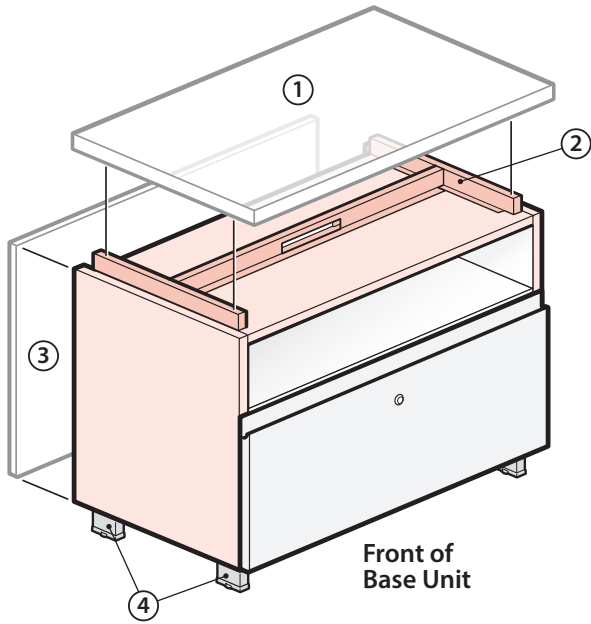

Base Unit Components:

- ① **Storage Top**
• Required – Must be separately specified.
- ② **Spacer**
• Included with Base Unit
- ③ **Finished Back**
• Optional– Must be separately specified.
- ④ **Legs**
• Included with Base Unit.
• Available with optional Straight Leg (F) or Chamfer Leg (P).
- ⑤ **Unfinished Inset Back**

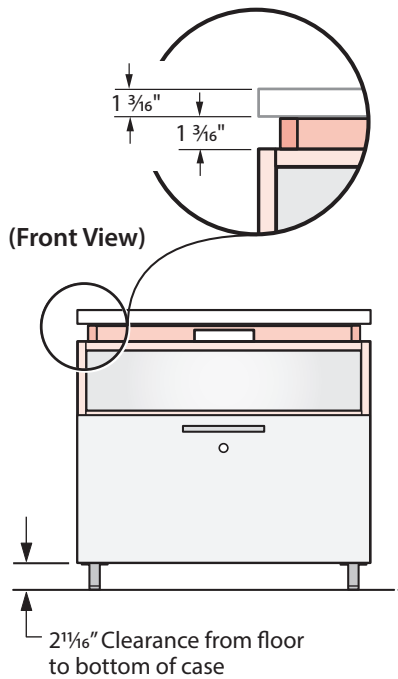
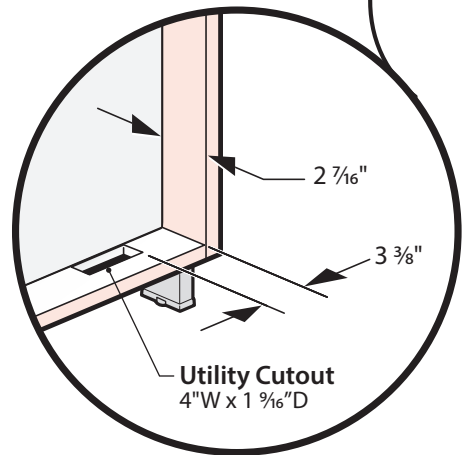

(Side View)

Leg Options:

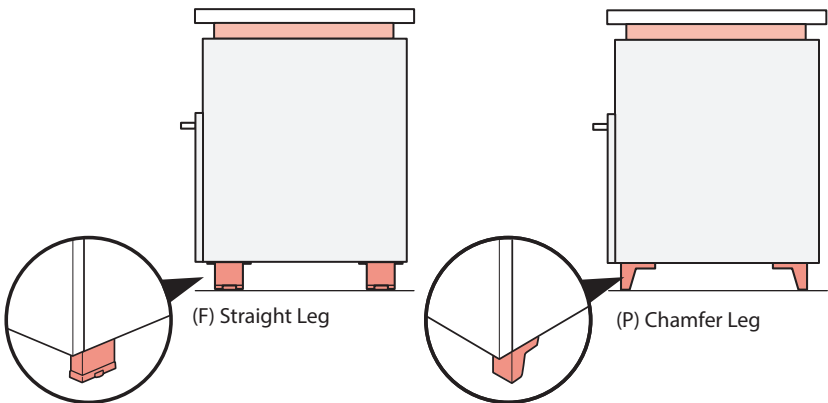

Product Details – Beside Storage

Base Units – Widths and Functional Sections

Another variable is a single, double or triple unit. This determines the number of functional sections within the Base Unit.

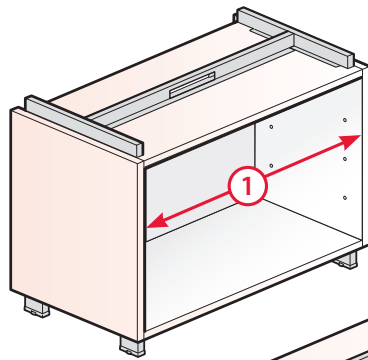

SINGLE WIDTH

- One functional section.
- 24", 30", 36" or 42" overall widths (depending on product offering - check price list for availability).

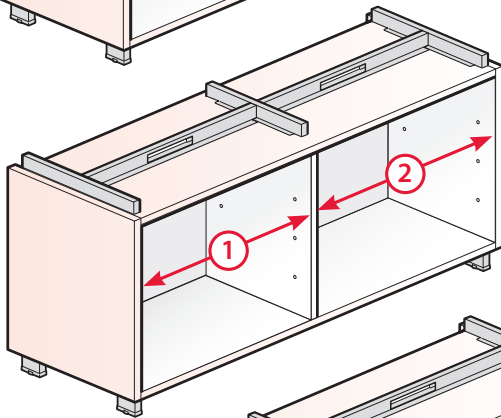

DOUBLE WIDTH

- Two functional sections.
- 24", 30", 36", 42", 48", 60" or 72" overall widths (depending on product offering - check price list for availability)

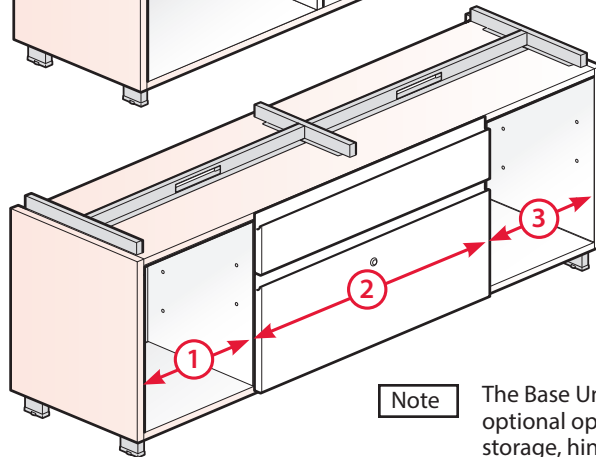

TRIPLE WIDTH

- Three functional sections.
- 48", 60" or 72" overall widths (depending on product configuration - check Price List for availability)

Note The Base Unit functional configuration determines the functionality with optional open, open with drawer, drawer combinations, hinged door open storage, hinged door combination and sliding door units.

Beside Storage Base Unit Heights & Configurations For Storage Based Planning:

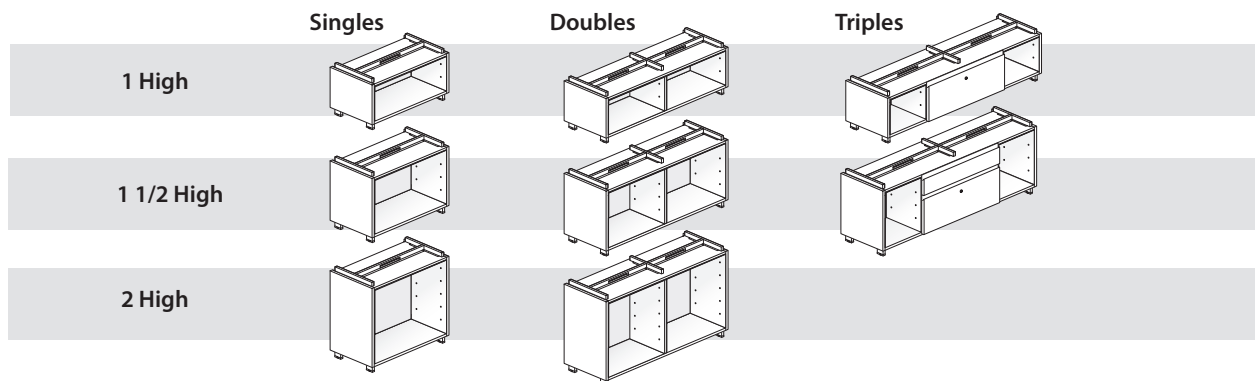

WIDTH	Base Unit Width	24" (23 7/8")	30" (29 7/8")	36" (35 7/8")	42" (41 7/8")	48" (47 7/8")	60" (59 7/8")	72" (71 7/8")
	Nominal (Actual)	Wide	Wide	Wide	Wide	Wide	Wide	Wide

Product Details – Beside Storage

Base Units – Finished Heights

Base Units require a separately specified Storage Top. The height of the Base Unit and the Storage Top are added together to provide the finished height of a Base Unit.

Base Units are available in three heights:

- **ONE-HIGH**
(17 ³/₁₆" finished height)
- **ONE AND ONE-HALF HIGH**
(23 ³/₁₆" finished height)
- **TWO-HIGH**
(29 ³/₁₆" finished height)

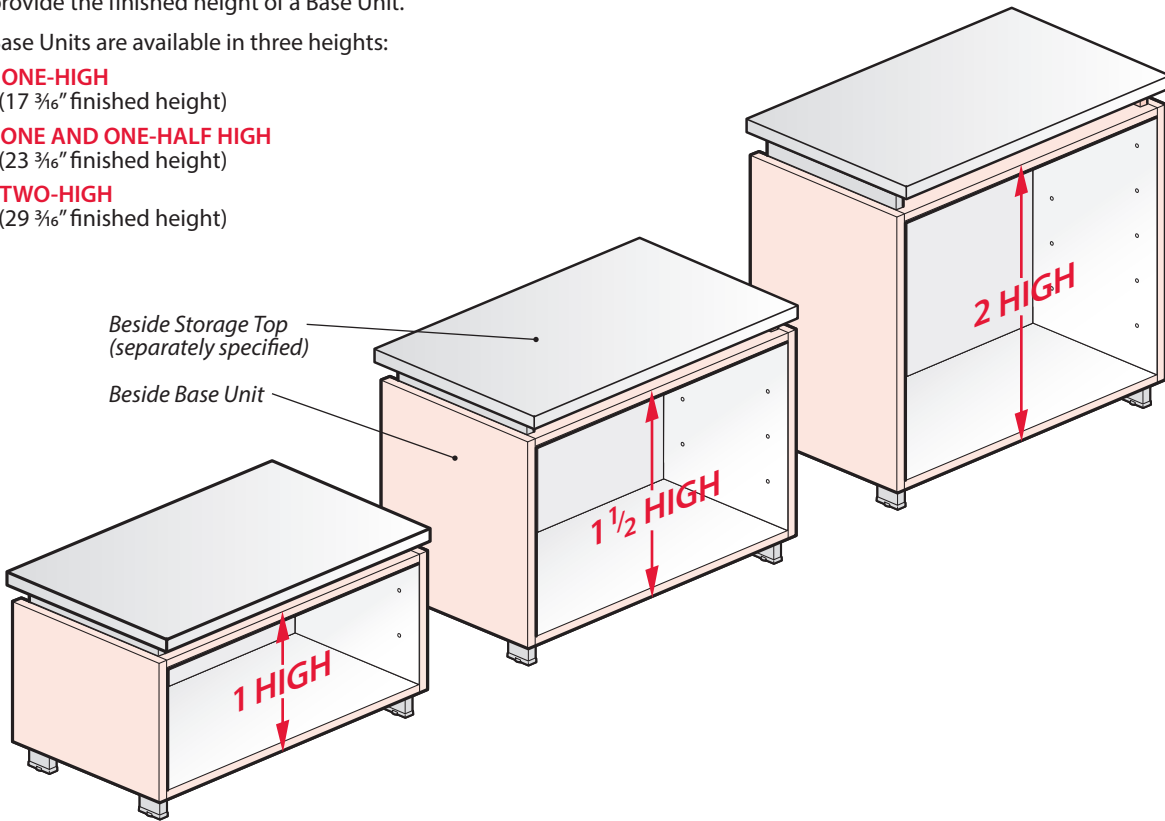

Front Views – Height (with glides extended 1/2") and Width

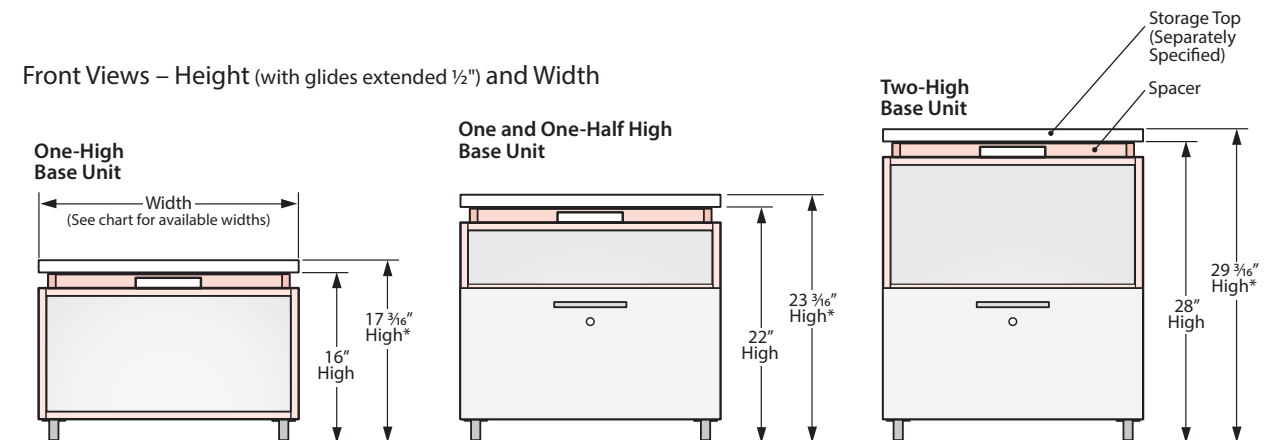

* with glides extended 1/2"

Glide Adjustment Range:

- Straight Leg: 1 1/2"
- Chamfer Leg: 1 1/4"

Tip • Storage Tops are required and must be separately specified.

Note • Finished heights includes Beside Storage Top (separately specified), Base Unit, spacer and legs.
• Glide adjustment range: Straight Legs 1 1/2" and Chamfer Leg 1 1/4".

Product Details – Beside Storage

Base Units – Depth

Side Views - Depth

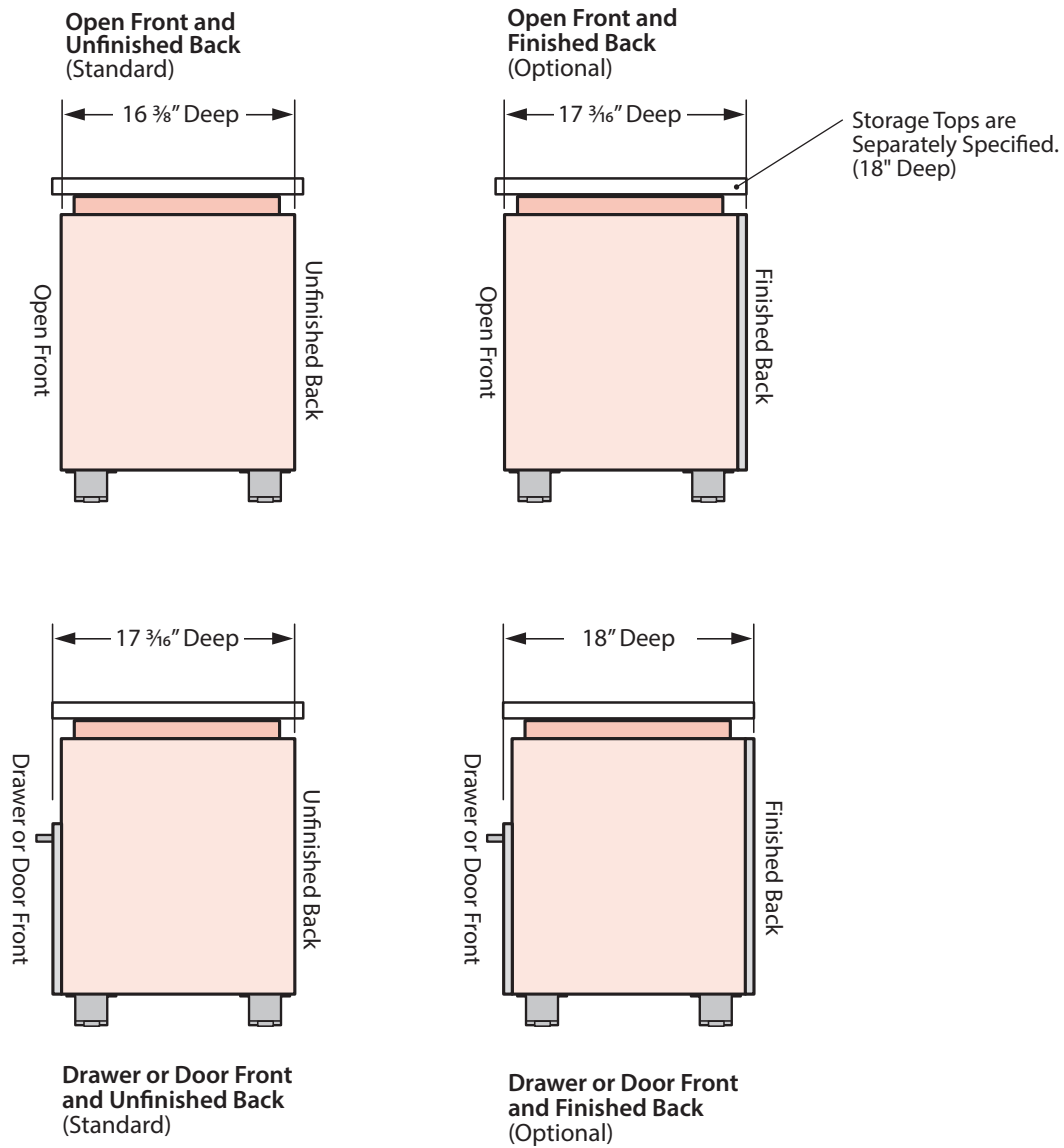

Note • Base Unit dimensions vary per case functionality and configuration; dimensions are specific to the Base Unit shown.

Tip • Finished Back is optional and must be separately specified.

Product Details – Beside Storage

Base Units – Spacer Dimensions

Single Width Base Unit

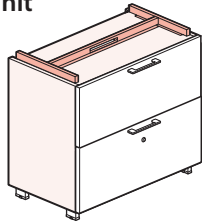

24", 30", 36" and 42" Wide Base Units
• Includes (1) Utility Cutout

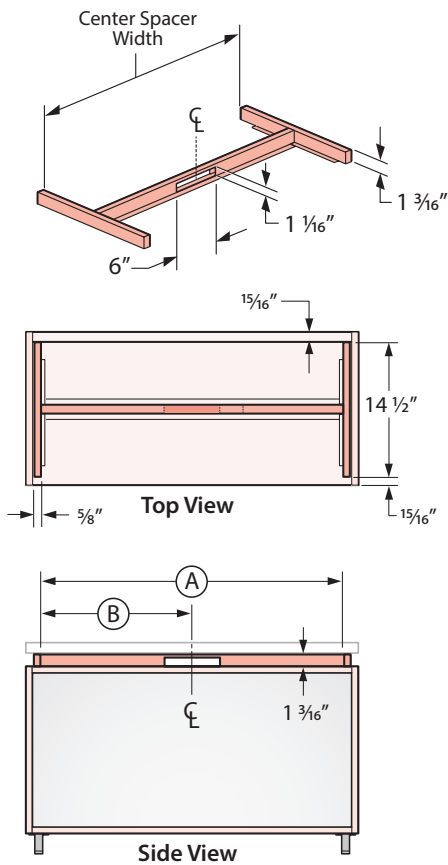

Double Width Base Unit

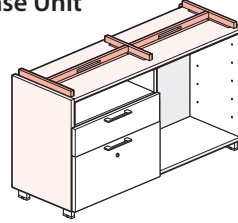

Triple Width Base Unit

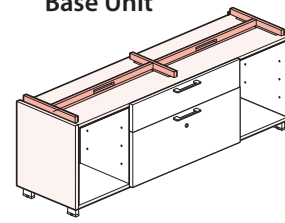

48", 60" and 72" Wide Base Units
• Includes (2) Utility Cutouts
• Additional Center Support

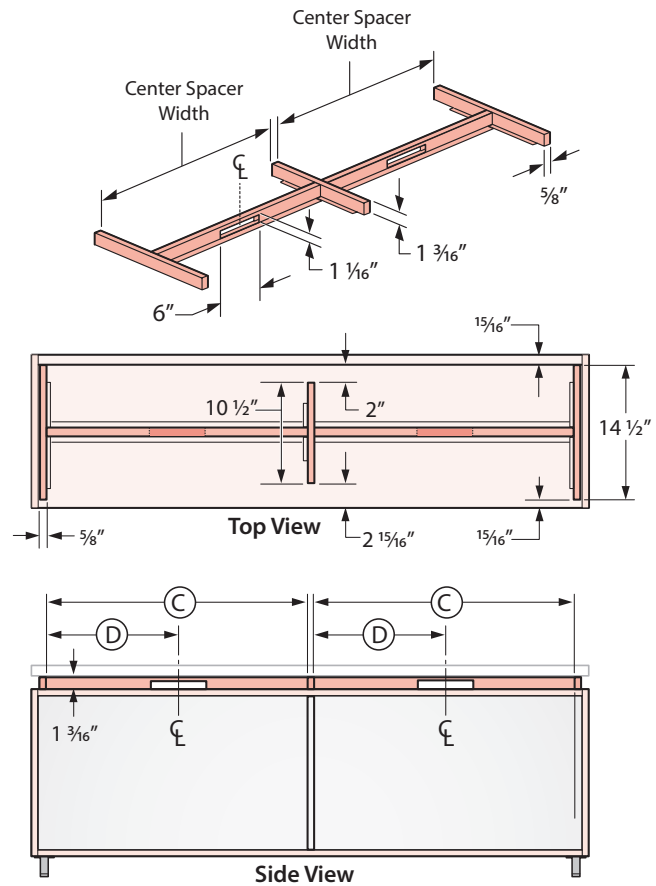

24", 30", 36" and 42" Wide Base Units
(Single Width)

48", 60" and 72" Wide Base Units
(Double or Triple Width)

Base Unit Exterior Width Nominal (Actual)	24" (23 7/8") Wide	30" (29 7/8") Wide	36" (35 7/8") Wide	42" (41 7/8") Wide	48" (47 7/8") Wide	60" (59 7/8") Wide	72" (71 7/8") Wide
Center Spacer Width	(A) 20.48"	(A) 26.48"	(A) 32.48"	(A) 38.48"	(C) 21.85"	(C) 27.85"	(C) 33.85"
Cutout Location	(B) 10.24"	(B) 13.24"	(B) 16.24"	(B) 19.24"	(D) 10.93"	(D) 13.93"	(D) 16.93"

Note • Base Unit dimensions vary per case functionality and configuration; dimensions are specific to the Base Unit shown.

Tip • Storage Top is required and must be separately specified.
• Finished Back is optional and must be separately specified.

Product Details – Beside Storage

Base Units – Interior / Exterior Dimensions Base Units Open – Single Width

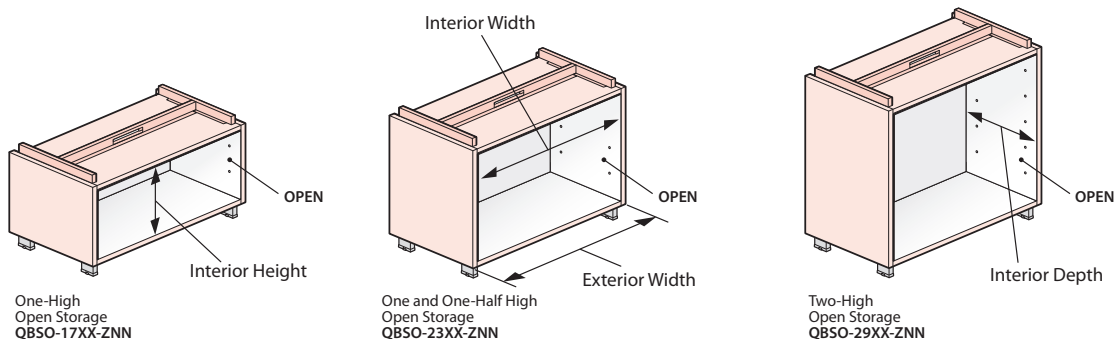

HEIGHT	Interior Height (Functional Sections)	One-High – 10 ⁹ / ₁₆ " High	One and One-Half High – 16 ⁹ / ₁₆ " High	Two-High – 22 ⁹ / ₁₆ " High	
	Exterior Width Nominal (Actual)	24" (23 ⁷ / ₈ ") Wide	30" (29 ⁷ / ₈ ") Wide	36" (35 ⁷ / ₈ ") Wide	42" (41 ⁷ / ₈ ") Wide
WIDTH	Interior Width (Functional Sections)	22 ³ / ₈ " Wide	28 ³ / ₈ " Wide	34 ³ / ₈ " Wide	40 ³ / ₈ " Wide
	Interior Depth (Functional Sections)	13 ¹³ / ₁₆ " Deep			
DEPTH					

Base Unit – Open – Double Width

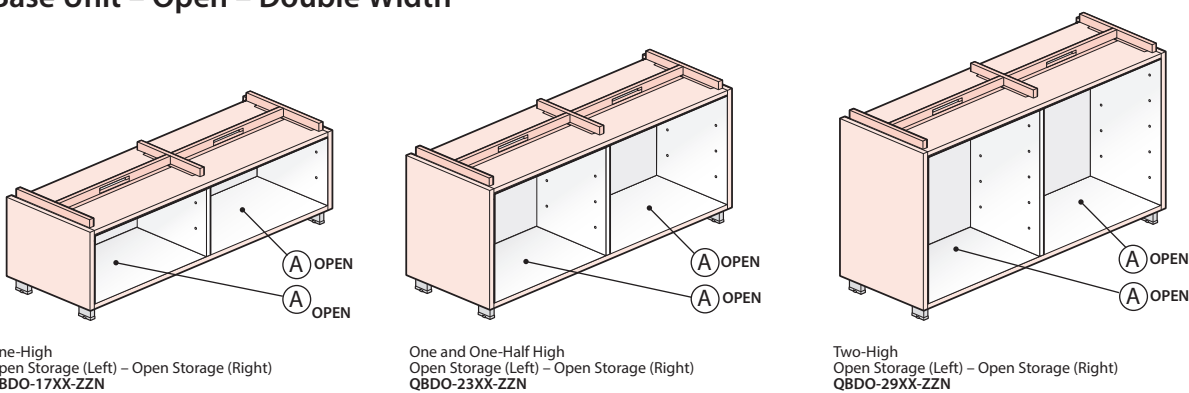

HEIGHT	Interior Height (Functional Sections)	One-High 10 ⁹ / ₁₆ " High	One and One-Half High 16 ⁹ / ₁₆ " High	Two-High 22 ⁹ / ₁₆ " High
	Exterior Width Nominal (Actual)	48" (47 ⁷ / ₈ ") Wide	60" (59 ⁷ / ₈ ") Wide	72" (71 ⁷ / ₈ ") Wide
WIDTH	Interior Width (Functional Sections)	Ⓐ 22 ¹³ / ₁₆ " Wide	Ⓐ 28 ¹³ / ₁₆ " Wide	Ⓐ 34 ¹³ / ₁₆ " Wide
	Interior Depth (Functional Sections)	Ⓐ 13 ¹³ / ₁₆ " Deep		
DEPTH				

Note • All interior dimensions are actual.
• Base Unit dimensions vary per case functionality and configuration; dimensions are specific to the Base Unit shown.

Tip • Storage Top is required and must be separately specified.
• Finished Back is optional and must be separately specified as needed.
• Binders taller than 10 ⁹/₁₆" won't fit upright in One High Base Units.

Product Details – Beside Storage

Base Units – Interior / Exterior Dimensions Base Unit – Open Storage with a Drawer – Single Width

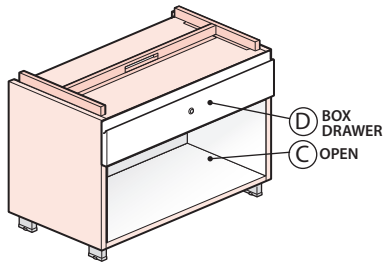

One and One-Half High
Box Drawer/Open
QBSF-23XX-CNN

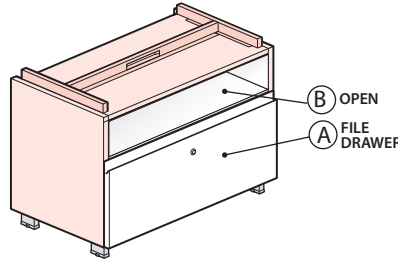

One and One-Half High
Open/File Drawer
QBSF-23XX-DNN

HEIGHT	Interior Height (Functional Sections)	Ⓐ 10 3/16" High* Ⓑ 5 5/16" High Ⓒ 11 3/8" High Ⓓ 4 3/16" High*		
	Exterior Width Nominal (Actual)	24" (23 7/8") Wide	30" (29 7/8") Wide	36" (35 7/8") Wide
WIDTH	Interior Width (Functional Sections)	Ⓐ Ⓓ 20 13/16" Wide* Ⓑ Ⓒ 22 3/8" Wide	Ⓐ Ⓓ 26 13/16" Wide* Ⓑ Ⓒ 28 3/8" Wide	Ⓐ Ⓓ 32 13/16" Wide* Ⓑ Ⓒ 34 3/8" Wide
	Interior Depth (Functional Sections)	Ⓐ Ⓓ 13 5/16" Deep* Ⓑ Ⓒ 13 13/16" Deep		

* Dimensions are to the interior of the drawer not the case.

Base Unit – Open Storage with a Drawer – Single Width

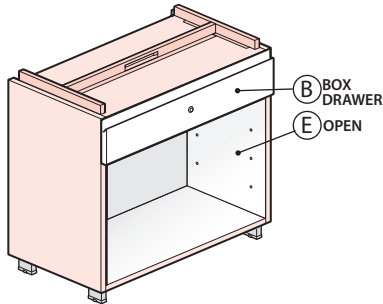

Two-High
Box/Open
QBSF-29XX-CNN

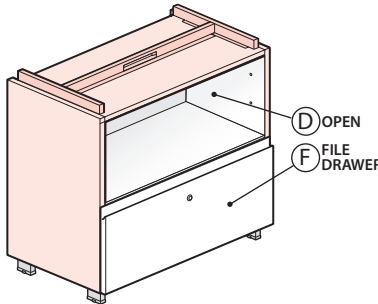

Two-High
Open/File Drawer
QBSF-29XX-DNN

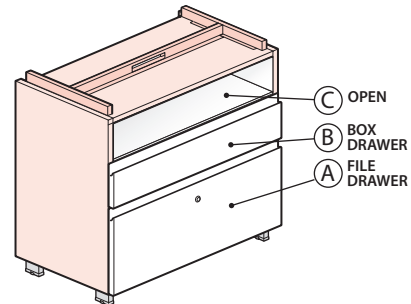

Two-High
Open/Box/File Drawer
QBSF-29XX-FNN

HEIGHT	Interior Height (Functional Sections)	Ⓐ 11" High* Ⓑ 4 3/16" High* Ⓒ 5 5/16" High Ⓓ 11 5/16" High Ⓔ 17 3/8" High Ⓕ 10 3/16" High*		
	Exterior Width Nominal (Actual)	24" (23 7/8") Wide	30" (29 7/8") Wide	36" (35 7/8") Wide
WIDTH	Interior Width (Functional Sections)	Ⓐ Ⓑ Ⓕ 20 13/16" Wide Ⓒ Ⓓ Ⓔ 22 3/8" Wide	Ⓐ Ⓑ Ⓕ 26 13/16" Wide Ⓒ Ⓓ Ⓔ 28 3/8" Wide	Ⓐ Ⓑ Ⓕ 32 13/16" Wide Ⓒ Ⓓ Ⓔ 34 3/8" Wide
	Interior Depth (Functional Sections)	Ⓐ Ⓑ Ⓕ 13 5/16" Deep Ⓒ Ⓓ Ⓔ 13 13/16" Deep		

* Dimensions are to the interior of the drawer not the case

Note • Base Unit dimensions vary per case functionality and configuration; dimensions are specific to the Base Unit shown.

- Tip**
- Storage Top is required and must be separately specified.
 - Finished Back is optional and must be separately specified as needed.
 - Binders taller than 10 9/16" won't fit upright in One High Base Units.

Product Details – Beside Storage

Base Units – Interior / Exterior Dimensions

Base Unit – Open Storage with a Drawer – Double Width

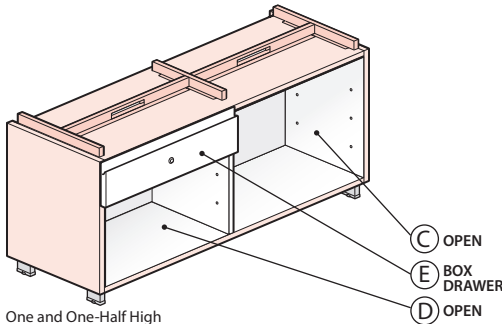

One and One-Half High
Box Drawer/12" Open (Left) – Open (Right)
QBDF-23XX-CZN

Alternative Configuration:
Open (Left) – 12" Open / Box Drawer (Right)
QBDF-23XX-ZCN

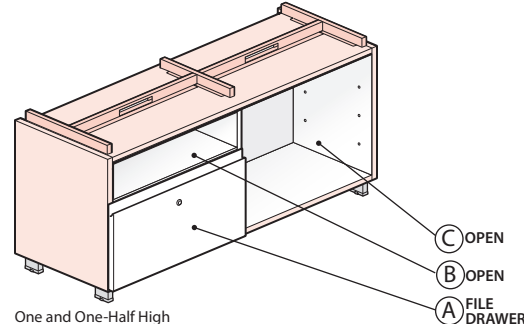

One and One-Half High
Open/File Drawer (Left) – Open (Right)
QBDF-23XX-DZN

Alternative Configuration:
Open (Left) – 6" Open/File Drawer (Right)
QBDF-23XX-ZDN

HEIGHT	Interior Height (Functional Sections)	A 10 3/16" High* B 5 5/16" High C 16 9/16" High D 11 3/8" High E 4 3/16" High*		
	Exterior Width Nominal (Actual)	48" (47 7/8") Wide	60" (59 7/8") Wide	72" (71 7/8") Wide
WIDTH	Interior Width (Functional Sections)	A E 20 13/16" Wide* B D 22 7/16" Wide C 23 3/16" Wide	A E 26 13/16" Wide* B D 28 7/16" Wide C 29 3/16" Wide	A E 32 13/16" Wide* B D 34 7/16" Wide C 35 3/16" Wide
	Interior Depth (Functional Sections)	A E 13 9/16" Deep* B C D 13 13/16" Deep		

* Dimensions are to the interior of the drawer not the case.

Base Unit – Open Storage with a Drawer – Double Width

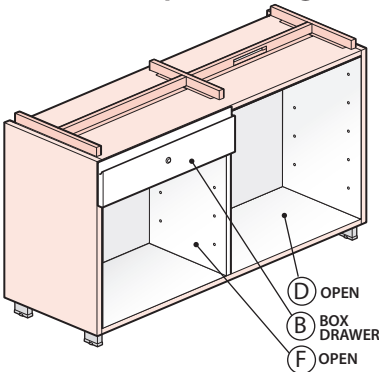

Two-High
Box Drawer/18" Open (Left) – Open (Right)
QBDF-29XX-CZN

Alternative Configuration:
Open (Left) – Box Drawer/18" Open (Right)
QBDF-29XX-ZCN

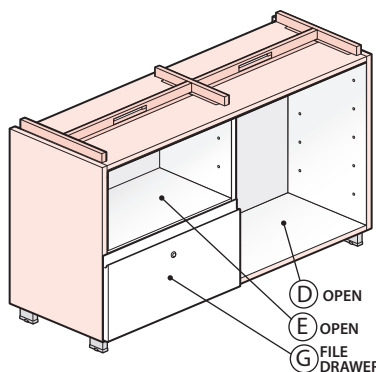

Two-High
12" Open/File Drawer (Left) – Open (Right)
QBDF-29XX-DZN

Alternative Configuration:
Open (Left) – 12" Open/File Drawer (Right)
QBDF-29XX-ZDN

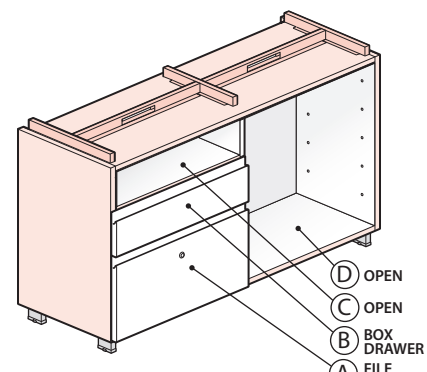

Two-High
6" Open/Box Drawer/File Drawer (Left) – Open (Right)
QBDF-29XX-FZN

Alternative Configuration:
Open (Left) – 6" Open/Box Drawer/File Drawer (Right)
QBDF-29XX-ZFN

HEIGHT	Interior Height (Functional Sections)	A 11" High* B 4 3/16" High* C 5 5/16" High D 22 9/16" High E 11 5/16" High F 17 3/8" High G 10 3/16" High*		
	Exterior Width Nominal (Actual)	48" (47 7/8") Wide	60" (59 7/8") Wide	72" (71 7/8") Wide
WIDTH	Interior Width (Functional Sections)	A B G 20 13/16" Wide* C E F 22 7/16" W D 23 3/16" W	A B G 26 13/16" Wide* C E F 28 7/16" W D 29 3/16" W	A B G 32 13/16" Wide* C E F 34 7/16" W D 35 3/16" W
	Interior Depth (Functional Sections)	A B G 13.56" Deep* C D E F 13.79" Deep		

* Dimensions are to the interior of the drawer not the case.

Note

- All interior dimensions are actual.
- Base Unit dimensions vary per case functionality and configuration; dimensions are specific to the Base Unit shown.

Tip

- Storage Top is required and must be separately specified.
- Finished Back is optional and must be separately specified as needed.
- Binders taller than 10 9/16" won't fit upright in One High Base Units.

Product Details – Beside Storage

Base Units – Interior / Exterior Dimensions Base Unit – Drawer Combinations – Single Width

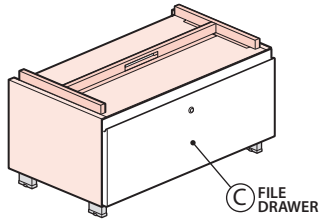

One-High
File Drawer
QBSF-17XX-ANN

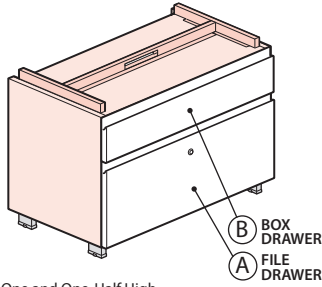

One and One-Half High
Box Drawer / File Drawer
QBSF-23XX-BNN

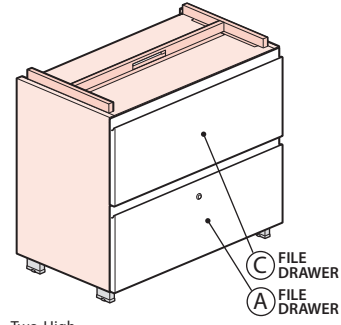

Two-High
Lateral File Drawer / File Drawer
QBSF-29XX-ENN

HEIGHT	Interior Height (Functional Sections)	Ⓐ 11" High* Ⓑ 4 3/16" High* Ⓒ 10 3/16" High*		
	Exterior Width Nominal (Actual)	24" (23 7/8") Wide	30" (29 7/8") Wide	36" (35 7/8") Wide
WIDTH	Interior Width (Functional Sections)	Ⓐ Ⓑ Ⓒ 20 13/16" Wide*	Ⓐ Ⓑ Ⓒ 26 13/16" Wide*	Ⓐ Ⓑ Ⓒ 32 13/16" Wide*
	Interior Depth (Functional Sections)	Ⓐ Ⓑ Ⓒ 13 1/16" Deep*		

* Dimensions are to the interior of the drawer not the case.

Base Unit – Drawer Combinations – Double Width

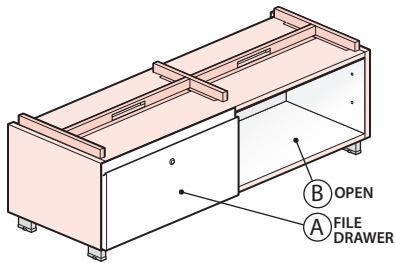

One-High
File Drawer (Left) – Open Storage (Right)
QBDF-17XX-AZN

Alternative Configuration:
Open Storage (Left) – File Drawer (Right)
QBDF-17XX-ZAN

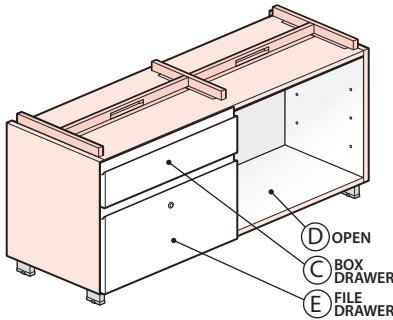

One and One-Half High
Box Drawer/File Drawer (Left) – Open Storage (Right)
QBDF-23XX-BZN

Alternative Configuration:
Open Storage (Left) – Box Drawer/File Drawer (Right)
QBDF-23XX-ZBN

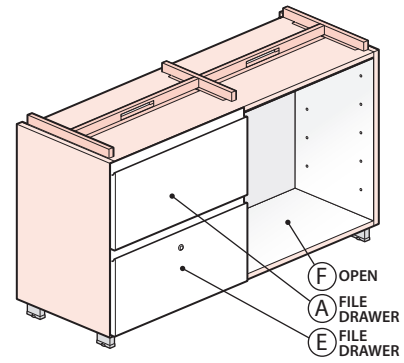

Two-High
File Drawer/File Drawer (Left) – Open Storage (Right)
QBDF-29XX-EZN

Alternative Configuration:
Open Storage (Left) – File Drawer/File Drawer (Right)
QBDF-29XX-ZEN

HEIGHT	Interior Height (Functional Sections)	Ⓐ 10 3/16" High* Ⓑ 10 9/16" High Ⓒ 4 3/16" High* Ⓓ 16 9/16" High Ⓔ 11" High* Ⓕ 22 9/16" High					
	Exterior Width Nominal (Actual)	48" (47 7/8") Wide		60" (59 7/8") Wide		72" (71 7/8") Wide	
WIDTH	Interior Width (Functional Sections)	Ⓐ Ⓒ Ⓔ 20 13/16" Wide* Ⓑ Ⓓ Ⓕ 23 3/16" Wide		Ⓐ Ⓒ Ⓔ 26 13/16" Wide* Ⓑ Ⓓ Ⓕ 29 3/16" Wide		Ⓐ Ⓒ Ⓔ 32 13/16" Wide* Ⓑ Ⓓ Ⓕ 35 3/16" Wide	
	Interior Depth (Functional Sections)	Ⓐ Ⓒ Ⓔ 13 1/16" Deep*			Ⓑ Ⓓ Ⓕ 13 13/16" Deep		

* Dimensions are to the interior of the drawer not the case.

Note • All interior dimensions are actual.
• Base Unit dimensions vary per case functionality and configuration; dimensions are specific to the Base Unit shown.

Tip • Storage Top is required and must be separately specified.
• Finished Back is optional and must be separately specified as needed.
• Binders taller than 10 9/16" won't fit upright in One High Base Units.

Product Details – Beside Storage

Base Units – Interior / Exterior Dimensions Base Unit – Drawer Combinations – Triple Width

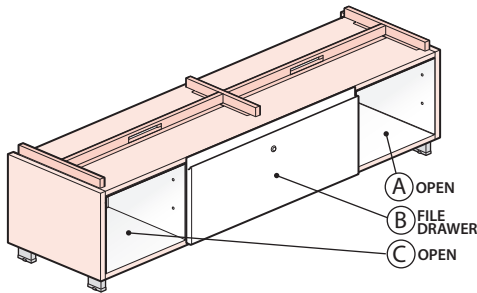

One High
Open Storage (Left)– File Drawer (Center)– Open Storage (Right)
QBTF-17XX-ZAZ

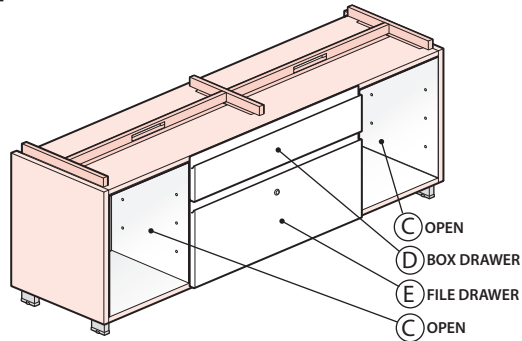

One and One-Half High
Open Storage (Left) – Box Drawer/File Drawer (Center) – Open Storage (Right)
QBTF-23XX-ZBZ

HEIGHT	Interior Height (Functional Sections)	(A) 10 9/16" High (B) 10 3/16" High* (C) 16 9/16" High (D) 4 3/16" High* (E) 11" High*		
	Exterior Width Nominal (Actual)	48" (47 7/8") Wide	60" (59 7/8") Wide	72" (71 7/8") Wide
WIDTH	Interior Width (Functional Sections)	(A) (C) 11 1/4" Wide (B) (D) (E) 20 13/16" Wide*	(A) (C) 14 1/4" Wide (B) (D) (E) 26 13/16" Wide*	(A) (C) 17 1/4" Wide (B) (D) (E) 32 13/16" Wide*
	Interior Depth (Functional Sections)	(A) (C) 13 13/16" Deep (B) (D) (E) 13 9/16" Deep*		

* Dimensions are to the interior of the drawer not the case.

Base Unit – Hinged Door – Single Width

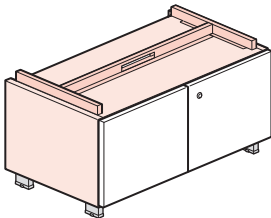

One-High
Hinged Door
QBSF-17XX-GNN

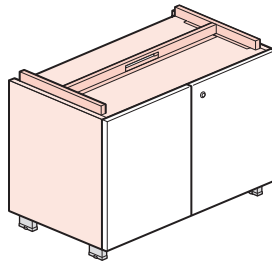

One and One-Half High
Hinged Door
QBSF-23XX-HNN

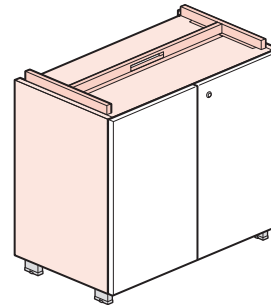

Two-High
Hinged Door
QBSF-29XX-JNN

HEIGHT	Interior Height (Functional Sections)	One-High – 10 9/16" High	One and One-Half High – 16 9/16" High	Two-High – 22 9/16" High	
	Exterior Width Nominal (Actual)	24" (23 7/8") Wide	30" (29 7/8") Wide	36" (35 7/8") Wide	42" (41 7/8") Wide
WIDTH	Interior Width (Functional Sections)	22 3/8" Wide	28 3/8" Wide	34 3/8" Wide	40 3/8" Wide
	Interior Depth (Functional Sections)	13 13/16" Deep			

Note • All interior dimensions are actual.
• Base Unit dimensions vary per case functionality and configuration; dimensions are specific to the Base Unit shown.

Tip • Storage Top is required and must be separately specified.
• Finished Back is optional and must be separately specified as needed.
• Binders taller than 10 9/16" won't fit upright in One High Base Units.

Product Details – Beside Storage

Base Units – Interior / Exterior Dimensions Base Unit – Hinged Door – Double Width

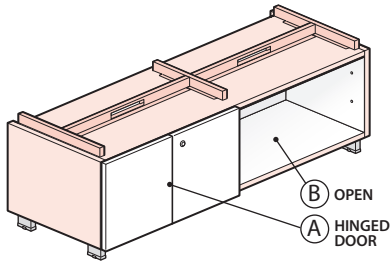

One-High Hinged Door (Left) – Open (Right)
QBDF-17XX-GZN
Alternative Configuration:
Open (Left) – 12" Hinged Door (Right)
QBDF-17XX-ZGN

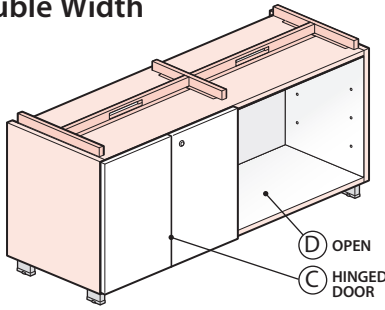

One and One-Half High Hinged Door (Left) – Open (Right)
QBDF-23XX-HZN
Alternative Configuration:
Open (Left) – 18" Hinged Door (Right)
QBDF-23XX-ZHN

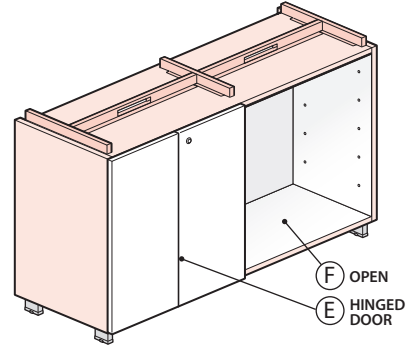

Two-High Hinged Door (Left) – Open (Right)
QBDF-29XX-JZN
Alternative Configuration:
Open (Left) – 24" Hinged Door (Right)
QBDF-29XX-ZJN

HEIGHT	Interior Height (Functional Sections)	Ⓐ Ⓑ 10 9/16" High Ⓒ Ⓓ 16 9/16" High Ⓔ Ⓕ 22 9/16" High		
	Exterior Width (Nominal (Actual))	48" (47 7/8") Wide	60" (59 7/8") Wide	72" (71 7/8") Wide
WIDTH	Interior Width (Functional Sections)	Ⓐ Ⓒ Ⓔ 22 7/16" Wide Ⓑ Ⓓ Ⓕ 23 3/16" Wide	Ⓐ Ⓒ Ⓔ 28 7/16" Wide Ⓑ Ⓓ Ⓕ 29 3/16" Wide	Ⓐ Ⓒ Ⓔ 34 7/16" Wide Ⓑ Ⓓ Ⓕ 35 3/16" Wide
	Interior Depth (Functional Sections)	Ⓐ Ⓑ Ⓒ Ⓓ Ⓔ Ⓕ 13 13/16" Deep		

Base Unit – Hinged Door – Triple Width

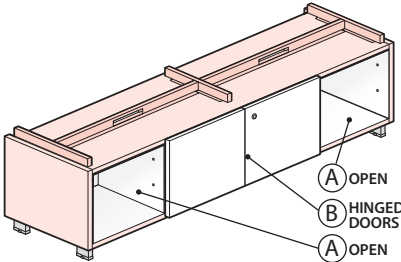

One-High Open (Left) – Hinged Door (Center) – Open (Right)
QBTF-17XX-ZGZ

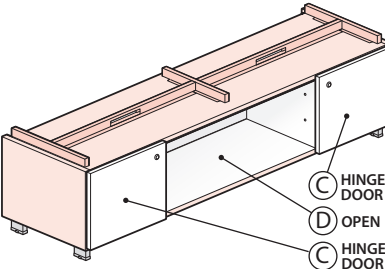

One-High Hinged Door (Left) – Open (Center) – Hinged Door (Right)
QBTF-17XX-GZG

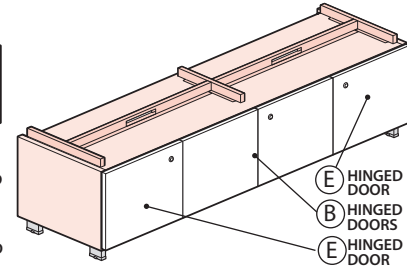

One-High Hinged Door (Left) – Hinged Door (Center) – Hinged Door (Right)
QBTF-17XX-GGG

HEIGHT	Interior Height (Functional Sections)	Ⓐ Ⓑ Ⓒ Ⓓ Ⓔ 10 9/16" High		
	Exterior Width (Nominal (Actual))	48" (47 7/8") Wide	60" (59 7/8") Wide	72" (71 7/8") Wide
WIDTH	Interior Width (Functional Sections)	Ⓐ Ⓔ 11 1/4" Wide Ⓑ 22 3/8" Wide Ⓒ 10 1/2" Wide Ⓓ 23 7/8" Wide	Ⓐ Ⓔ 14 1/4" Wide Ⓑ 28 3/8" Wide Ⓒ 13 1/2" Wide Ⓓ 29 7/8" Wide	Ⓐ Ⓔ 17 1/4" Wide Ⓑ 34 3/8" Wide Ⓒ 16 1/2" Wide Ⓓ 35 7/8" Wide
	Interior Depth (Functional Sections)	Ⓐ Ⓑ Ⓒ Ⓓ Ⓔ 13 13/16" Deep		

Note • All interior dimensions are actual.
• Base Unit dimensions vary per case functionality and configuration; dimensions are specific to the Base Unit shown.

Tip • Storage Top is required and must be separately specified.
• Finished Back is optional and must be separately specified as needed.
• Binders taller than 10 9/16" won't fit upright in One High Base Units.

Product Details – Beside Storage

Base Units – Interior / Exterior Dimensions Base Unit – Hinged Door – Triple Width

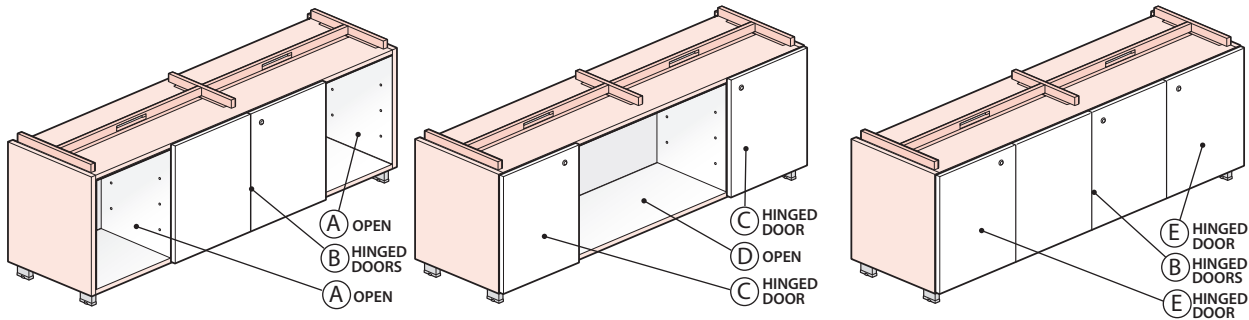

One and One-Half High
Open (Left) – Hinged Door (Center) – Open (Right)
QBTF-23XX-ZHZ

One and One-Half High
Hinged Door (Left) – Open (Center) – Hinged Door (Right)
QBTF-23XX-HZH

One and One-Half High
Hinged Door(Left)-Hinged Door(Right)
QBTF-23XX-HHH

HEIGHT	Interior Height (Functional Sections)	Ⓐ Ⓑ Ⓒ Ⓓ Ⓔ 16 ⁵ / ₁₆ " High		
	Exterior Width Nominal (Actual)	48" (47 ⁷ / ₈ " Wide	60" (59 ⁷ / ₈ " Wide	72" (71 ⁷ / ₈ " Wide
WIDTH	Interior Width (Functional Sections)	Ⓐ Ⓔ 11 ¹ / ₄ " Wide Ⓑ 22 ³ / ₈ " Wide	Ⓐ Ⓔ 14 ¹ / ₄ " Wide Ⓑ 28 ³ / ₈ " Wide	Ⓐ Ⓔ 17 ¹ / ₄ " Wide Ⓑ 34 ³ / ₈ " Wide
		Ⓒ 10 ¹ / ₂ " Wide Ⓓ 23 ⁷ / ₈ " Wide	Ⓒ 13 ¹ / ₂ " Wide Ⓓ 29 ⁷ / ₈ " Wide	Ⓒ 16 ¹ / ₂ " Wide Ⓓ 35 ⁷ / ₈ " Wide
DEPTH	Interior Depth (Functional Sections)	Ⓐ Ⓑ Ⓒ Ⓓ Ⓔ 13 ¹³ / ₁₆ " Deep		

Base Unit – Hinged Door and Open Storage Unit – Single Width

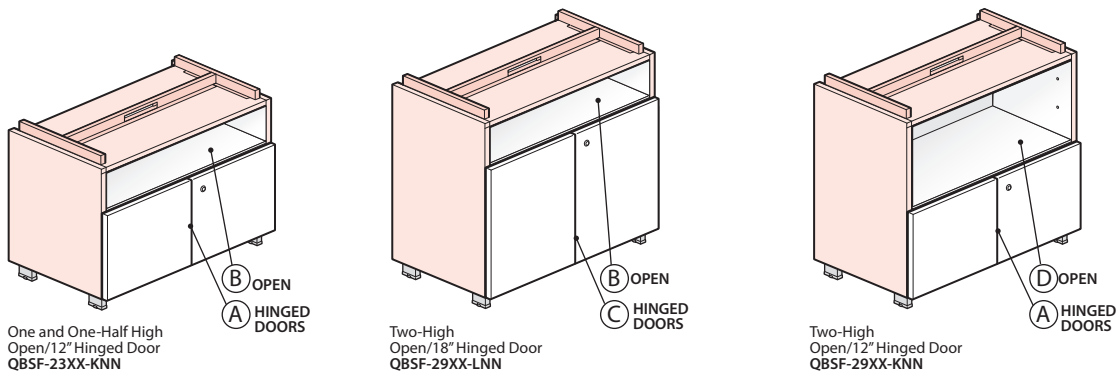

One and One-Half High
Open/12" Hinged Door
QBSF-23XX-KNN

Two-High
Open/18" Hinged Door
QBSF-29XX-LNN

Two-High
Open/12" Hinged Door
QBSF-29XX-KNN

HEIGHT	Interior Height (Functional Sections)	Ⓐ 10 ⁹ / ₁₆ " High Ⓑ 5 ⁵ / ₁₆ " High Ⓒ 16 ⁹ / ₁₆ " High Ⓓ 11 ⁵ / ₁₆ " High			
	Exterior Width Nominal (Actual)	24" (23 ⁷ / ₈ " Wide	30" (29 ⁷ / ₈ " Wide	36" (35 ⁷ / ₈ " Wide	42" (41 ⁷ / ₈ " Wide
WIDTH	Interior Width (Functional Sections)	Ⓐ Ⓒ Ⓑ Ⓓ 22 ³ / ₈ " Wide	Ⓐ Ⓒ Ⓑ Ⓓ 28 ³ / ₈ " W	Ⓐ Ⓒ Ⓑ Ⓓ 34 ³ / ₈ " Wide	Ⓐ Ⓒ Ⓑ Ⓓ 40 ³ / ₈ " Wide
DEPTH	Interior Depth (Functional Sections)	Ⓐ Ⓑ Ⓒ Ⓓ 13 ¹³ / ₁₆ " Deep			

Note • All interior dimensions are actual.
• Base Unit dimensions vary per case functionality and configuration; dimensions are specific to the Base Unit shown.

Tip • Storage Top is required and must be separately specified.
• Finished Back is optional and must be separately specified as needed.

Product Details – Beside Storage

Base Units – Interior / Exterior Dimensions

Double Base Unit – Hinged Door and Open Storage Units – Double Width

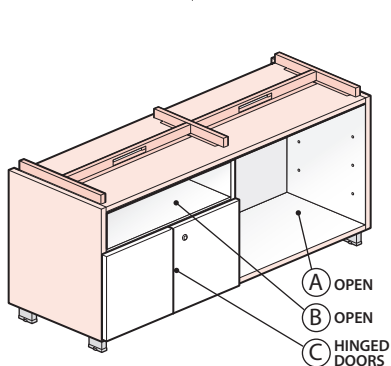

One and One-Half High
Open/12" Hinged Door(Left) – Open (Right)
QBDF-23XX-KZN
Alternative Configuration:
Open (Left) – Open/ Hinged Door(Right)
QBDF-23XX-ZKN

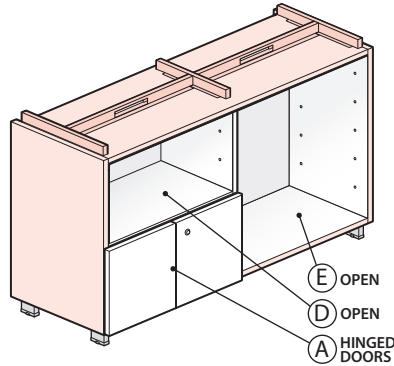

Two-High
Open/12" Hinged Door (Left) – Open(Right)
QBDF-29XX-KZN
Alternative Configuration:
Open (Left) – Open/Hinged Door (Right)
QBDF-29XX-ZKN

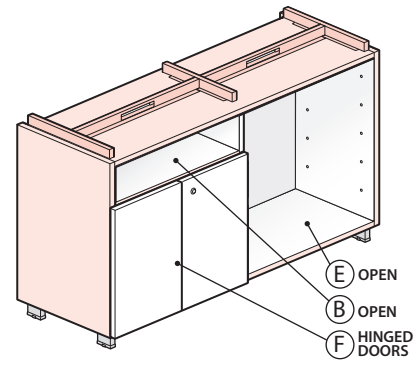

Two-High
Open/ Hinged Door (Left) – Open Right (Right)
QBDF-29XX-LZN
Alternative Configuration:
Open (Left) – Open/ Hinged Door(Right)
QBDF-29XX-ZLN

HEIGHT	Interior Height (Functional Sections)	Ⓐ 10 9/16" High Ⓑ 5 5/16" High Ⓒ Ⓕ 16 9/16" High Ⓓ 11 5/16" High Ⓔ 22 9/16" High		
	Exterior Width Nominal (Actual)	48" (47 7/8") Wide	60" (59 7/8") Wide	72" (71 7/8") Wide
WIDTH	Interior Width (Functional Sections)	Ⓐ Ⓑ Ⓓ Ⓕ 22 7/16" Wide Ⓒ Ⓔ 23 3/16" Wide	Ⓐ Ⓑ Ⓓ Ⓕ 28 7/16" Wide Ⓒ Ⓔ 29 3/16" Wide	Ⓐ Ⓑ Ⓓ Ⓕ 34 7/16" Wide Ⓒ Ⓔ 35 3/16" Wide
	Interior Depth (Functional Sections)	Ⓐ Ⓑ Ⓒ Ⓓ Ⓔ Ⓕ 13 13/16" Deep		

Base Unit – Hinged Door and Drawer Combination – Single Width

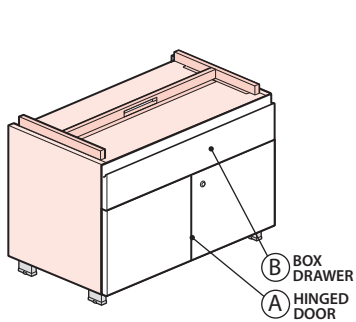

One and One-Half High
Box Drawer/Hinged Door
QBSF-23XX-MNN

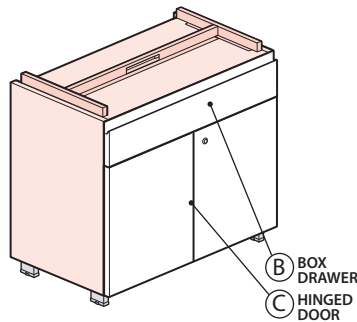

One and One-Half High
Box Drawer/Hinged Door
QBSF-29XX-ONN

HEIGHT	Interior Height (Functional Sections)	Ⓐ 11 3/8" High Ⓑ 4 3/16" High* Ⓒ 17 3/8" High		
	Exterior Width Nominal (Actual)	24" (23 7/8") Wide	30" (29 7/8") Wide	36" (35 7/8") Wide
WIDTH	Interior Width (Functional Sections)	Ⓐ Ⓒ 22 3/8" Wide Ⓑ 20 13/16" Wide*	Ⓐ Ⓒ 28 3/8" Wide Ⓑ 26 13/16" Wide*	Ⓐ Ⓒ 34 3/8" Wide Ⓑ 32 13/16" Wide*
	Interior Depth (Functional Sections)	Ⓐ Ⓒ 13 13/16" Deep Ⓑ 13 9/16" Deep*		

* Dimensions are to the interior of the drawer not the case.

Note

- All interior dimensions are actual.
- Base Unit dimensions vary by case functionality and configuration; dimensions are specific to the Base Unit shown.

Tip

- Storage Top is required and must be separately specified.
- Finished Back is optional and must be separately specified as needed.

Product Details – Beside Storage

Base Units – Interior / Exterior Dimensions

Base Unit – Hinged Door and Drawer Combination – Double Width

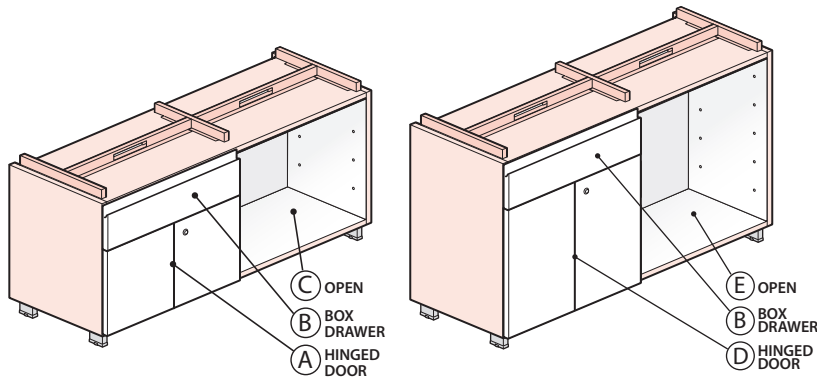

One and One-Half High
Box Drawer/Hinged Door (Left)– Open (Right)
QBDF-23XX-MZN

Alternative Configuration:
Open (Left) – Box Drawer/Hinged Door (Right)
QBDF-23XX-ZMN

One and One-Half High
Box Drawer/Hinged Door (Left)–Open (Right)
QBDF-29XX-OZN

Alternative Configuration:
Open (Left) – Box Drawer/Hinged Door (Right)
QBDF-29XX-ZON

HEIGHT	Interior Height (Functional Sections)	Ⓐ 11 3/8" High Ⓑ 4 3/16" High* Ⓒ 16 1/16" High Ⓓ 17 3/8" High Ⓔ 22 9/16" High		
	Exterior Width Nominal (Actual)	48" (47 7/8") Wide	60" (59 7/8") Wide	72" (71 7/8") Wide
WIDTH	Interior Width (Functional Sections)	Ⓐ Ⓓ 22 3/8" W Ⓑ 20 13/16" W*	Ⓐ Ⓓ 28 3/8" W Ⓑ 26 13/16" W*	Ⓐ Ⓓ 34 3/8" W Ⓑ 32 13/16" W*
		Ⓒ Ⓔ 23 3/16" W	Ⓒ Ⓔ 29 3/16" W	Ⓒ Ⓔ 35 13/16" W
DEPTH	Interior Depth (Functional Sections)	Ⓐ Ⓒ Ⓓ Ⓔ 13 13/16" Deep Ⓑ 13 9/16" Deep*		

* Dimensions are to the interior of the drawer not the case.

Base Unit – Hinged Door and Drawer Combination – Triple Width

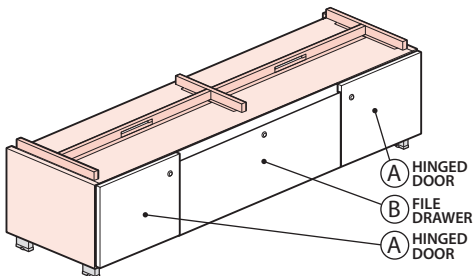

One-High
Hinged Door (Left) – File Drawer (Center) – Hinged Door (Right)
QBTF-17XX-GAG

HEIGHT	Interior Height (Functional Sections)	Ⓐ 10 9/16" High Ⓑ 10 3/16" High*		
	Exterior Width Nominal (Actual)	48" (47 7/8") Wide	60" (59 7/8") Wide	72" (71 7/8") Wide
WIDTH	Interior Width (Functional Sections)	Ⓐ 11 1/4" W Ⓑ 20 13/16" W*	Ⓐ 14 1/4" W Ⓑ 26 13/16" W*	Ⓐ 17 1/4" W Ⓑ 32 13/16" W*
DEPTH	Interior Depth (Functional Sections)	Ⓐ 13 13/16" Deep Ⓑ 13 9/16" Deep*		

* Dimensions are to the interior of the drawer not the case.

Note • All interior dimensions are actual.
• Base Unit dimensions vary per case functionality and configuration; dimensions are specific to the Base Unit shown.

Tip • Storage Top is required and must be separately specified.
• Finished Back is optional and must be separately specified as needed.
• Binders taller than 10 9/16" won't fit upright in One High Base Units.

Product Details – Beside Storage

Base Units – Interior / Exterior Dimensions

Base Unit – Hinged Door and Drawer Combination - Triple Width

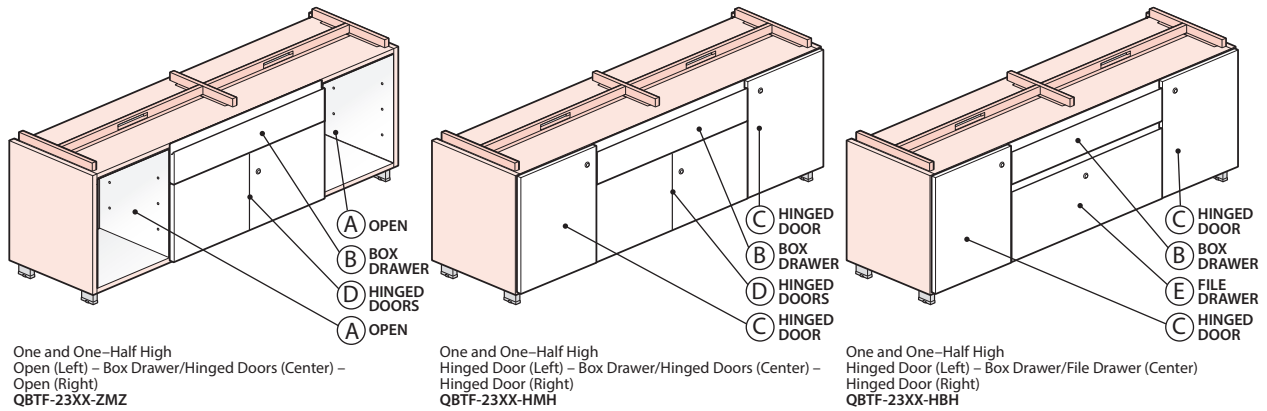

HEIGHT	Interior Height (Functional Sections)	A C 16 5/16" High B 4 3/16" High D 11 3/8" High E 11" High					
	Exterior Width Nominal (Actual)	48" (47 7/8") Wide		60" (59 7/8") Wide		72" (71 7/8") Wide	
WIDTH	Interior Width (Functional Sections)	A C 11 1/4" Wide		A C 14 1/4" Wide		A C 17 1/4" Wide	
	Interior Depth (Functional Sections)	B E 20 13/16" Wide D 22 3/8" Wide	B E 26 13/16" Wide D 28 3/8" Wide	B E 32 13/16" Wide D 34 3/8" Wide			
DEPTH	Interior Depth (Functional Sections)	A C D 13 13/16" Deep B E 13 5/16" Deep					

Base Unit – Single Sliding Door - Single Width

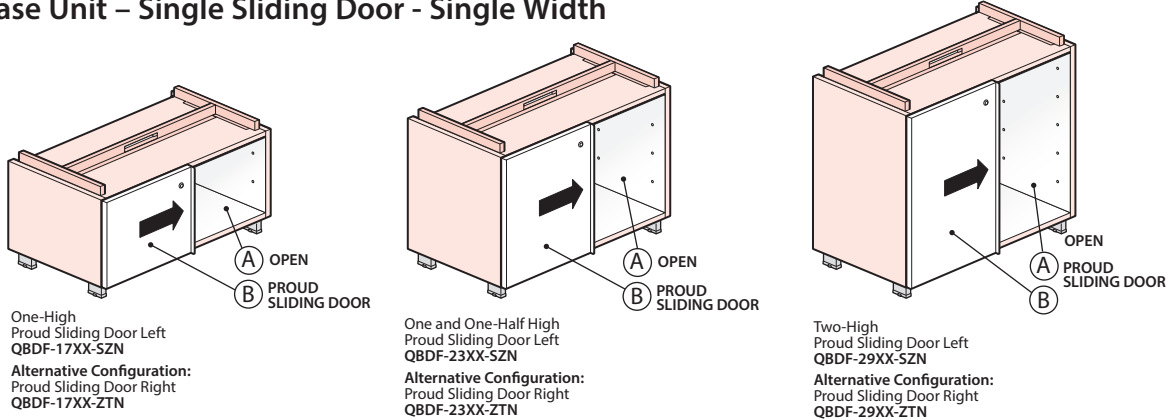

HEIGHT	Interior Height (Functional Sections)	One-High – 10 5/16" High		One and One-Half High – 16 5/16" High		Two-High – 22 5/16" High		
	Exterior Width Nominal (Actual)	24" (23 7/8") W	30" (29 7/8") W	36" (35 7/8") W	42" (41 7/8") W	48" (47 7/8") W	60" (59 7/8") W	72" (71 7/8") W
WIDTH	Interior Width (Functional Sections)	A 11 3/16" W B 10 7/16" W	A 14 3/16" W B 13 7/16" W	A 17 3/16" W B 16 7/16" W	A 20 3/16" W B 19 7/16" W	A 23 3/16" W B 22 7/16" W	A 29 3/16" W B 28 7/16" W	A 35 3/16" W B 34 7/16" W
	Interior Depth (Functional Sections)	A B 13 13/16" Deep						

Note • All interior dimensions are actual.
• Base Unit dimensions vary per case functionality and configuration; dimensions are specific to the Base Unit shown.

Tip • Storage Top is required and must be separately specified.
• Finished Back is optional and must be separately specified as needed.
• Binders taller than 10 5/16" won't fit upright in One High Base Units.

Product Details – Beside Storage

Base Units – Interior / Exterior Dimensions Base Unit – Double Sliding Door – Double Width

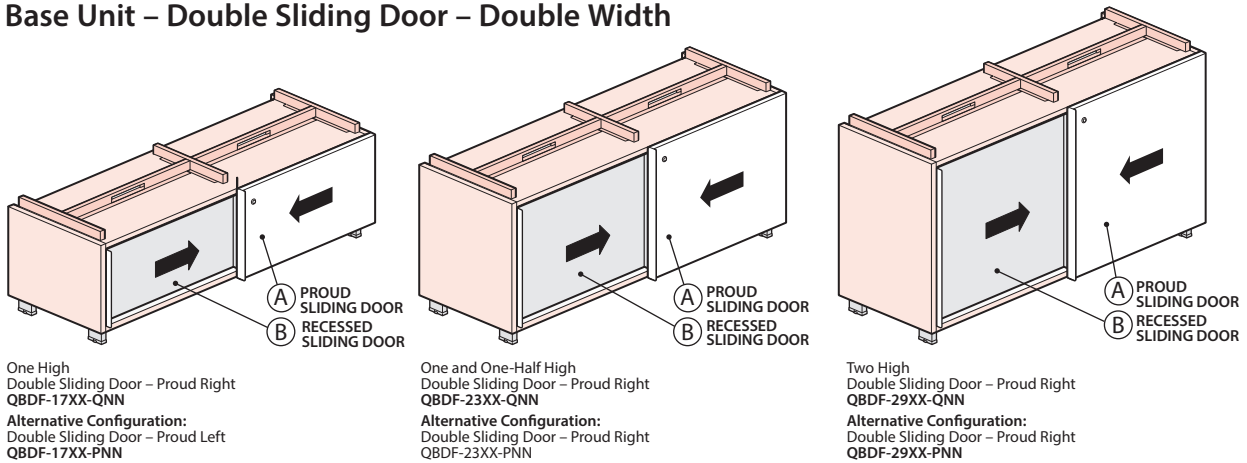

HEIGHT	Interior Height (Functional Sections)	One-High – 10 5/16" High		One and One-Half High – 16 5/16" High		Two-High – 22 5/16" High		
	Exterior Width Nominal (Actual)	24" (23 7/8") W	30" (29 7/8") W	36" (35 7/8") W	42" (41 7/8") W	48" (47 7/8") W	60" (59 7/8") W	72" (71 7/8") W
WIDTH	Interior Width (Functional Sections)	(A) 10 3/16" W (B) 10 7/16" W	(A) 13 3/16" W (B) 13 7/16" W	(A) 16 3/16" W (B) 16 7/16" W	(A) 19 3/16" W (B) 19 7/16" W	(A) 22 3/16" W (B) 22 7/16" W	(A) 28 3/16" W (B) 28 7/16" W	(A) 34 3/16" W (B) 34 7/16" W
	Interior Depth (Functional Sections)	(A) (B) 12 1/8" Deep						

Base Unit – Double Sliding Door – Triple Width

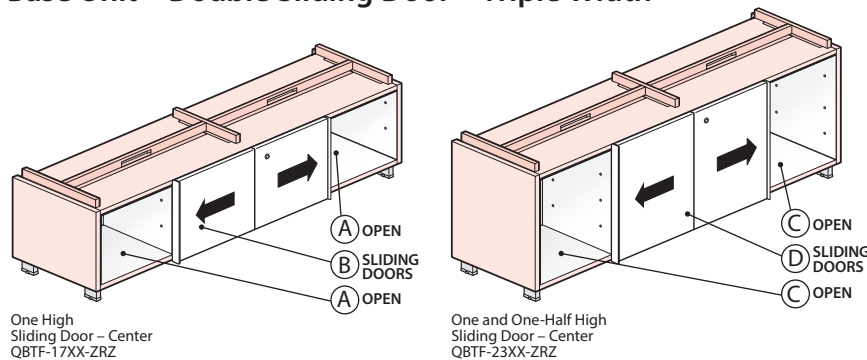

HEIGHT	Interior Height (Functional Sections)	(A) (B) 10 5/16" High (C) (D) 16 5/16" High		
	Exterior Width Nominal (Actual)	48" (47 7/8") Wide	60" (59 7/8") Wide	72" (71 7/8") Wide
WIDTH	Interior Width (Functional Sections)	(A) (C) 11 1/4" W (B) (D) 22 3/8" W	(A) (C) 14 1/4" W (B) (D) 28 3/8" W	(A) (C) 17 1/4" W (B) (D) 34 3/8" W
	Interior Depth (Functional Sections)	(A) (B) (C) (D) 13 5/16" Deep		

Note • All interior dimensions are actual.
• Base Unit dimensions vary per case functionality and configuration; dimensions are specific to the Base Unit shown.

Tip • Storage Top is required and must be separately specified.
• Finished Back is optional and must be separately specified as needed.
• Binders taller than 10 5/16" won't fit upright in One High Base Units.

Product Details – Beside Storage

Base Units – Drawer Capacity and Load

24" Wide File Drawer

Available with the following Base Unit sizes: 24"W Single Width Base Units, 48" W Double Base Unit and 48" W Triple Width Base Units.

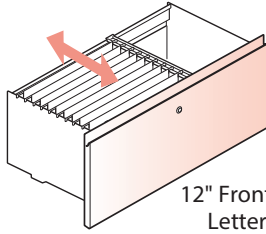

12" Front To Back Letter Filing

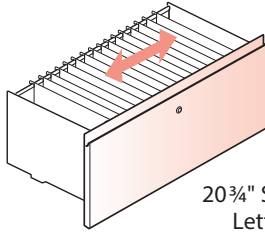

20 3/4" Side To Side Letter Filing

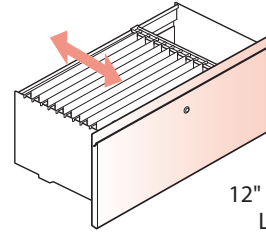

12" Front To Back Legal Filing

30" – Wide File Drawer

Available with the following Base Unit sizes: 30"W Single Width Base Units, 60"W Double Base Unit and 60" W Triple Width Base Units.

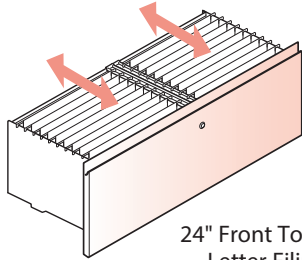

24" Front To Back Letter Filing

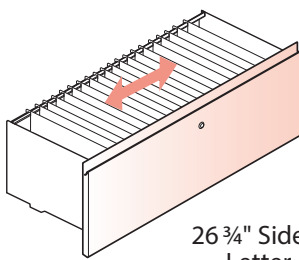

26 3/4" Side To Side Letter Filing

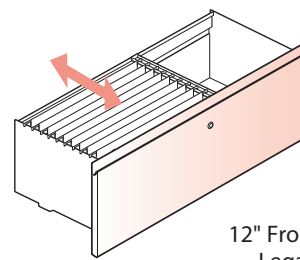

12" Front To Back Legal Filing

36" – Wide File Drawer

Available with the following Base Unit sizes: 36"W Single Width Base Units, 72"W Double Base Unit and 72" W Triple Width Base Units.

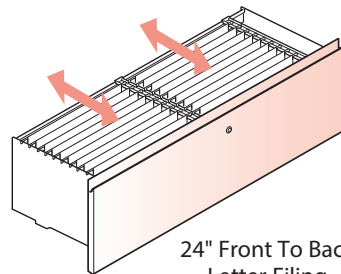

24" Front To Back Letter Filing

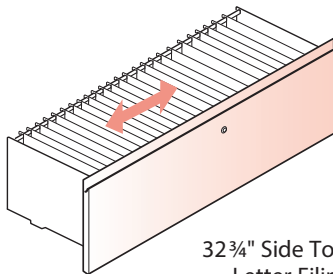

32 3/4" Side To Side Letter Filing

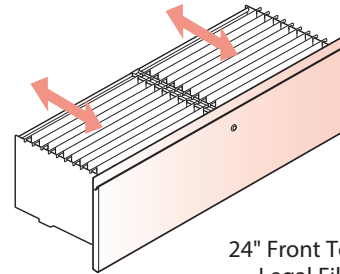

24" Front To Back Legal Filing

File Drawer Load Capacities

Nominal Size	Depth	Width	Load
12"D x 24"W	13 5/16"	20 13/16"	44 lbs.
12"D x 30"W	13 5/16"	26 13/16"	57 lbs.
12"D x 36"W	13 5/16"	32 13/16"	70 lbs.

Box Drawer Load Capacities

Nominal Size	Depth	Width	Load
6"D x 24"W	13 5/16"	20 13/16"	16 lbs.
6"D x 30"W	13 5/16"	26 13/16"	20 lbs.
6"D x 36"W	13 5/16"	32 13/16"	25 lbs.

Note

- Drawer load ratings are based on BIFMA load requirement of 0.017 lbs per cubic inch of drawer volume.
- Side-to-side hanging bar positions are provided in each lateral file drawer to allow depth adjustment for different hanging folder sizes.
- Due to the clear height – there may be interference with some Pendaflex tabs.

Product Details – Beside Storage

Base Units – Surface Materials and Finishes

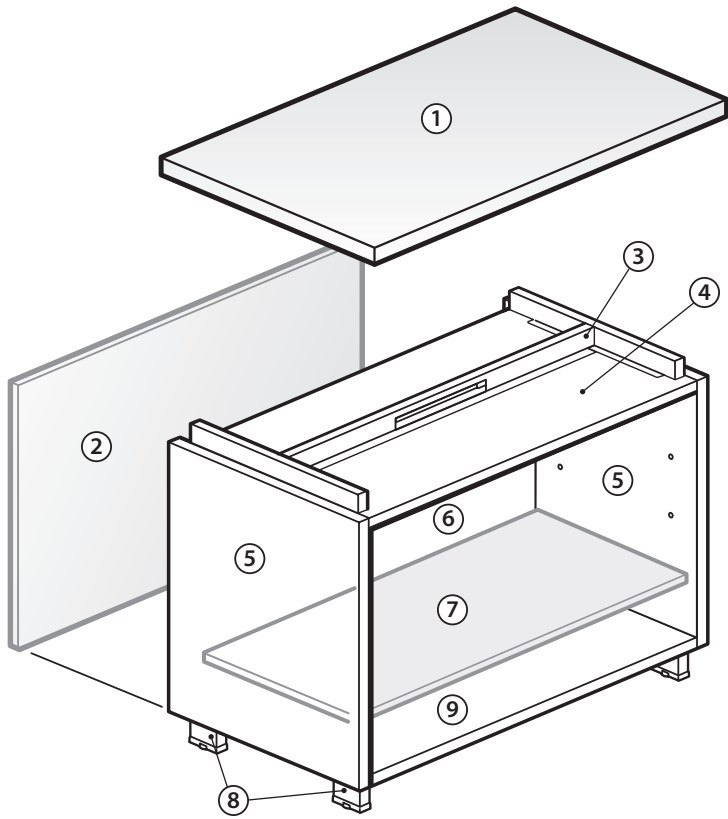

- ① **Beside Storage Top**
(Separately Specified)
• Laminate
• Wood Veneer
- ② **Beside Finished Back**
(Separately Specified)
• Painted Steel
• Laminate
• Wood Veneer
- ③ **Spacer**
• Painted Steel
- ④ **Inner Top**
• Laminate
- ⑤ **End Panels**
• Laminate
- ⑥ **Inset Back**
• Painted Steel
- ⑦ **Beside Accessory Shelf**
(Separately Specified)
• Painted Steel
- ⑧ **Legs**
• Painted Metal
- ⑨ **Base**
• Painted Steel

Functional Configurations

Storage Fronts:
• Painted Steel
• Laminate
• Wood Veneer

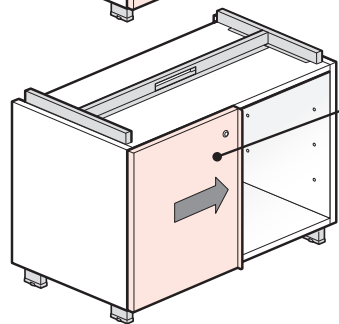
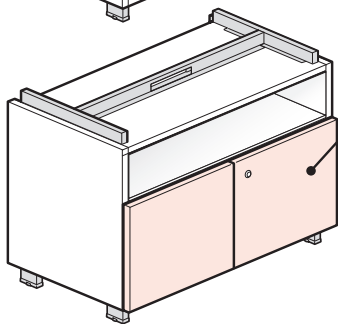
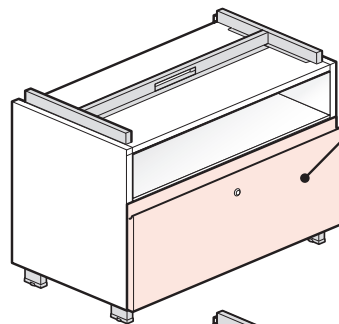
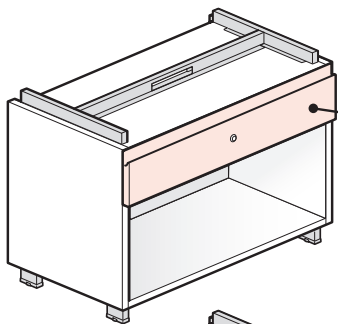

Note

- All Base Units require a separately specified Beside Storage Top.
- Accessory Shelves and finished backs are not included in Base Units and must be separately specified as needed.

Product Details – Beside Storage

Base Units – Order For Specifying Base Unit Colors

Base Units with Steel Fronts

To Order Base Units with Steel Fronts, Specify:

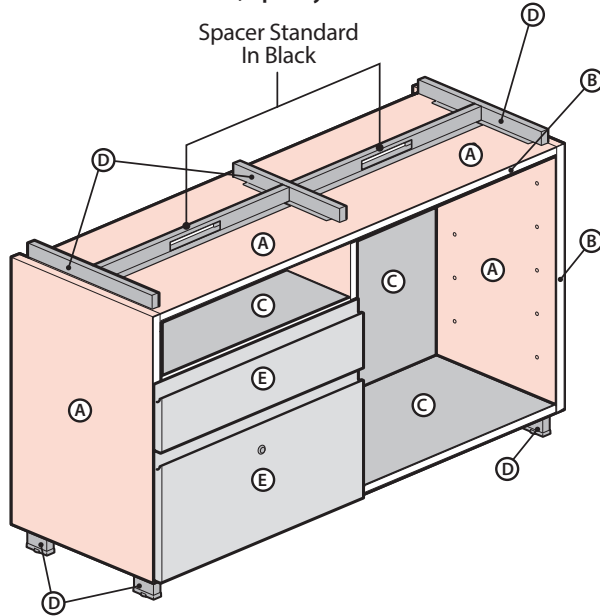

Option A
Laminate
Case Color

Option B
Laminate Case
Edgeband Color

Option C
Bottom, inset
back and fixed
shelf trim color

Option D
Leg and spacer
end trim color

Option E
Steel front color
(includes J-Pull)

- Note**
- All Base Units require a separately specified Beside Storage Top.
 - Shelves and finished backs are not included in Base Units and must be separately specified as needed.
 - Optional Lock comes standard in chrome.

Base Units with Laminate or Wood Fronts

To Order Base Units with Laminate or Wood Fronts, Specify:

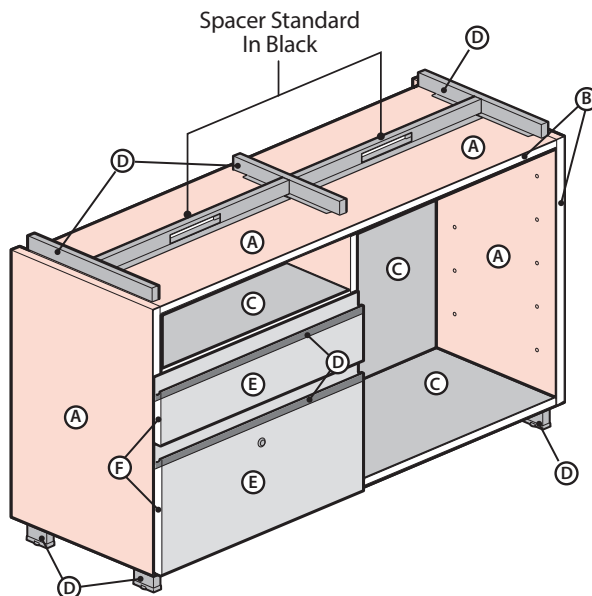

Option A
Case Color
- Laminate

Option B
Case Edgeband
Color - Laminate

Option C
Bottom, inset
back and fixed
shelf trim color

Option D
Pull, leg and spacer
end trim color

Option E
Material front
color

Option F
Material front
edgeband color
- Laminate

- Note**
- **All Base Units require a separately specified Beside Storage Top.**
 - **Accessory Shelves and finished backs are not included in Base Units and must be separately specified as needed.**
 - Options listed by location not order of specification.
 - Optional Lock comes standard in chrome.

Product Details – Beside Storage

Storage Top – Storage Tops for Beside Base Units

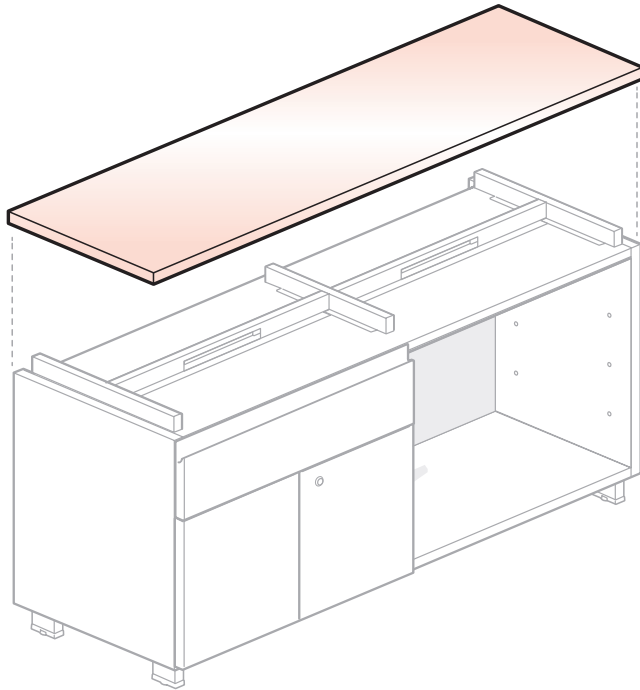

Separately specified Storage tops are required for all Base Units.

- Depths: 18" or 36"
- Widths: Range from 24" to 120"
- Available in laminate or wood with 3mm radius edgeband on front and back and 1mm edgeband on sides.
- Storage tops are for use with all heights - single, double or triple width Base Units.
- May be used on a single Base Unit or may span more than one side-by-side, in-line Base Units. Application may be mirrored for a back-to-back application.

REQUIRED for all Base Units

Separately Specified

Storage Top on single width Base Unit

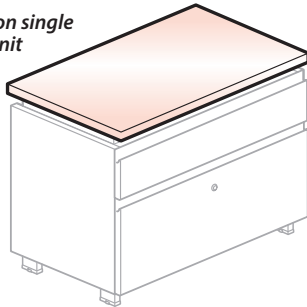

Storage Top spanning side-by-side, in-line Base Unit application

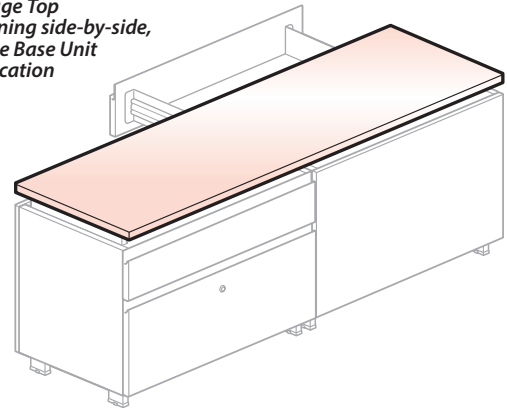

Storage Top on double width Base Unit

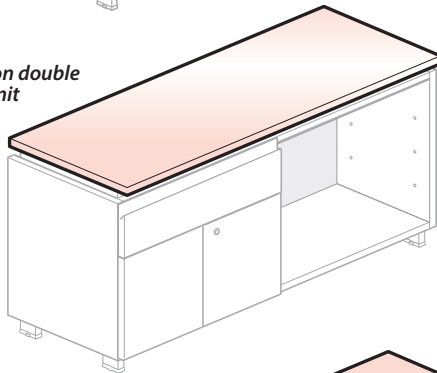

Storage Top spanning back-to-back Base Unit application

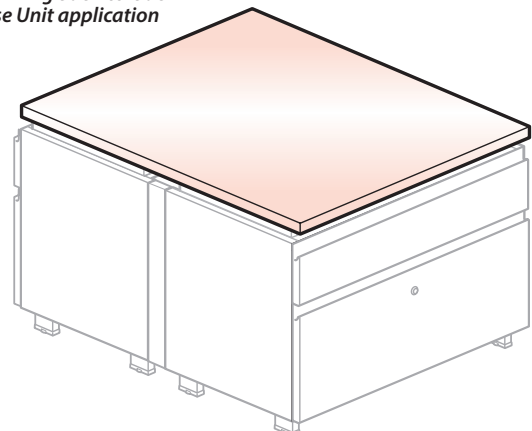

Storage Top on triple width Base Unit

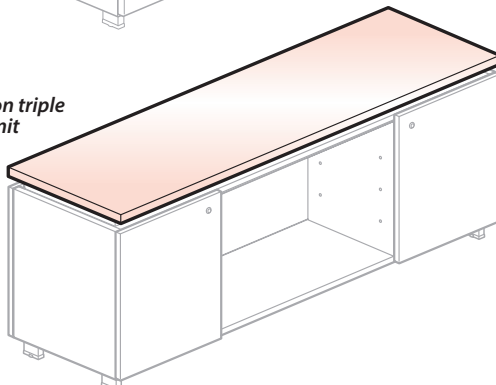

Product Details – Beside Storage

Finished Backs and Filler Panels

Finished Back for Beside Storage Base Units

Separately specified Finished Backs are needed to provide a finished back panel in an exposed back application.

- Widths range from 24" to 72".
- Finished Backs are available in steel, laminate or wood.
- Finished Backs are available for all Base Units heights: (One-High, One and One-Half High and Two-High)
- Finished Back width must match the Base Unit width.
- Not for use to span more than one side-by-side, in-line Base Units.
- Finished Backs add 3/4" to the depth of the Base Unit.
- Not for use with Filler Panels.

Separately Specified as needed

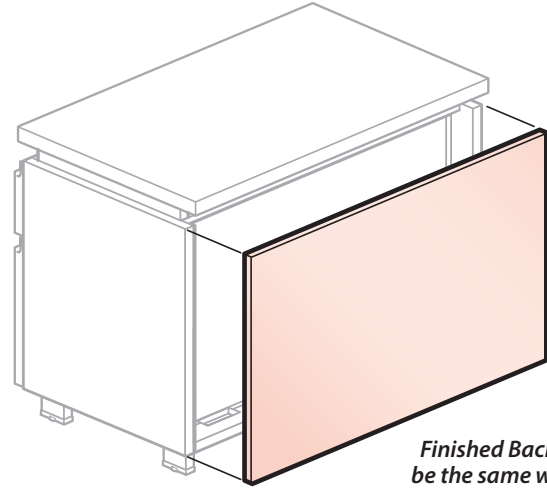

Finished Back must be the same width as the Base Unit.

Note • Finished Back is not for use with Filler Panels for dimensional reasons.

Filler Panel For Beside Storage Base Units

Separately specified Filler Panels are used to fill the open vertical gap between the back-to-back Base Units.

- Available in three depths and heights to accommodate specific applications:
 - 1.5" depth** fills the gap between two back-to-back Base Units with separately specified Storage Tops. This depth Filler Panel is used when the backs of the Storage Top are flush to each other without a gap.
 - 2.8" depth** fills the gap between two back-to-back Base Units with separately specified Storage Tops and one of the following component options: a Tool Rail, a Shared Screen or a Top Feed.
 - 5.1" depth** fills the gap between two back-to-back Base Units with separately specified Storage Tops, (2) Tool Rails and a Center Screen.

Separately Specified as needed

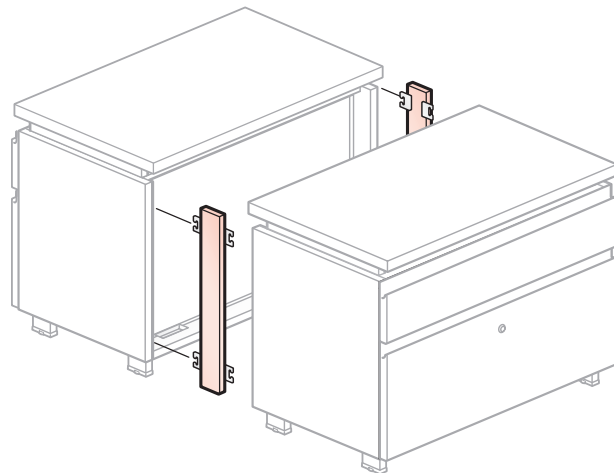

Note • Filler Panels do NOT gang units together. A separately specified ganging bracket is available for ganging Base Units to one another.
• Filler Panel is not for use with Finished Back for dimensional reasons.

Product Details – Beside Storage

Accessory Shelf for Beside Base Units

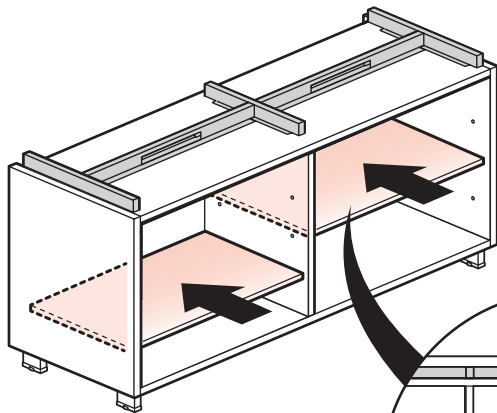

Separately specified accessory shelves are needed to provide additional storage within a Beside Base Unit.

- Accessory Shelf is painted steel.
- Shelves are not included in Base Units and must be separately specified as needed.
- Shelves are specified per Base Unit functionality; open, drawers, doors, etc...
- Refer to the price list for specification details.

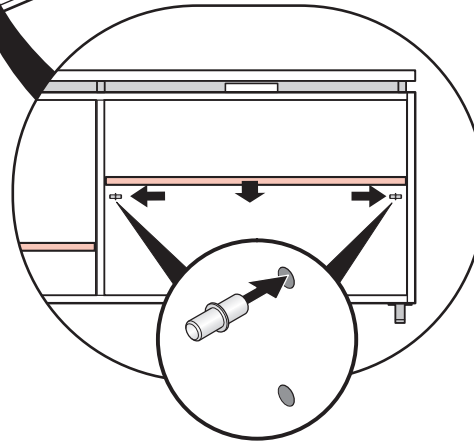

Single Width Base Units

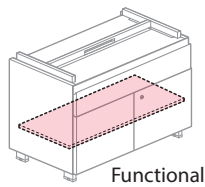
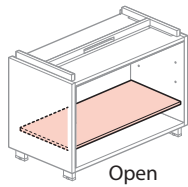

Double Width Base Units

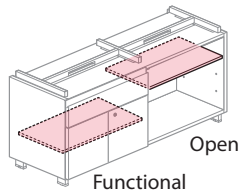
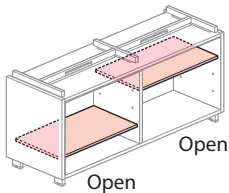

Single Sliding Door Base Units

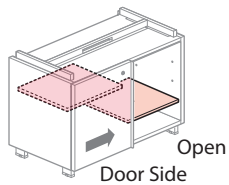

Double Sliding Doors Base Unit

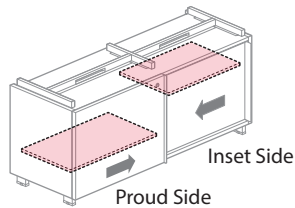

Triple Width Base Units

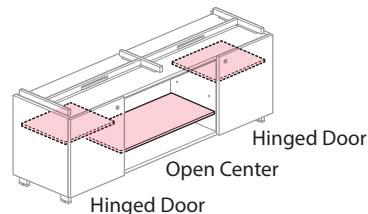
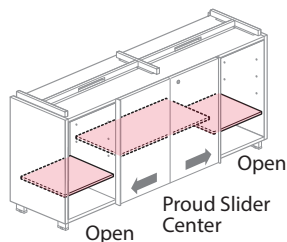
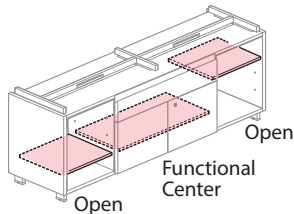

Product Details – Beside Storage

Brackets

Storage-to-Panel Bracket

Separately specified Storage-to-Panel Bracket is required for the following application:

- To attach a Base Unit to a systems panel. Specify bracket to match height of Base Unit; 17" height for One-high, 23" height for One and One-Half high, and 29" height for Two-high.
- Specify a systems application specific bracket for Compose, PREMISE or UniGroup application.

Separately Specified as needed.

Parallel to Panel
Storage-to-Panel Bracket
Left Handed Shown

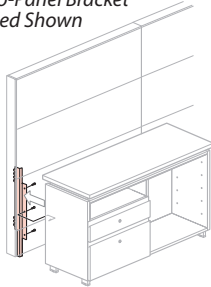

Perpendicular to Panel
Storage-to-Panel Bracket
Right Handed Shown

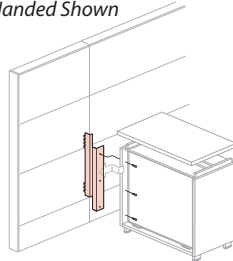

Note

- Storage-to-Panel Bracket on a Two-High Base Unit provides Group A Panel Floor Support.
- Storage-to-Panel Bracket on a One-and-One-Half high Base Unit provides Group B Panel Floor Support.
- Storage-to-Panel Bracket on a One-High Base Unit secures storage to panel.
- Must be planned on-modular.

Desk-to-Storage Bracket

Separately specified Desk-to-Storage Bracket is required for the following application:

- In a One and One-Half high storage based planning model (Base Units function as application spine): Reside Worksurfaces are located perpendicular to the storage spine.
- Desk-to-Storage Bracket attaches to the front or back of One and One-Half Base Unit providing Beside Base Unit and Reside Worksurface required support.

Separately Specified as needed

Half Cover – 9"

Aligns with mid point of Storage Top (for floating worksurface with 9" Overhang)

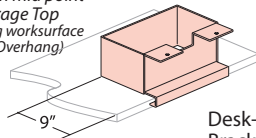

Full Cover – 13"

Flush with the back of Hutch (Hutch Application)

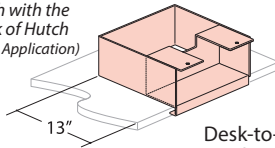

Full Cover – 18"

Flush with the back edge of Base Unit

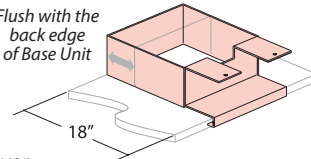

Desk-to-Storage Bracket – Half Cover
ZUBG-29__-PNHC

Desk-to-Storage Bracket – Full Cover
ZUBG-29__-PNFC

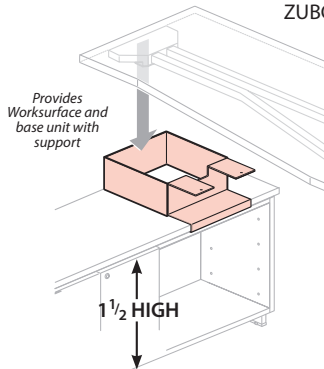

Note

The Half Cover or Full Cover Desk-to-Storage Bracket product specification options allow the floating worksurface overhang dimension to be 9", 13" or 18".

Half Cover Option: The half cover results in the end of the worksurface to align mid point of the Base Unit depth resulting in a 9" floating worksurface overhang.

Full Cover Option: The cover is multifunctional and offers two planning options. In the 18" deep position the full cover aligns the end of the floating worksurface to be flush with the back edge of Base Unit with no overhang or the 13" deep position is used in Hutch application to position the floating worksurface adjacent to the back of the Hutch.

Product Details – Beside Storage

Brackets

Storage Attachment Bracket

Separately specified Storage Attachment Bracket is required for the following applications:

- To support a One and One-Half high Base Unit with drawer(s).
- Storage Attachment Bracket attaches to front or back of One and One-Half high Base Unit providing required support.

☑ Separately Specified as needed

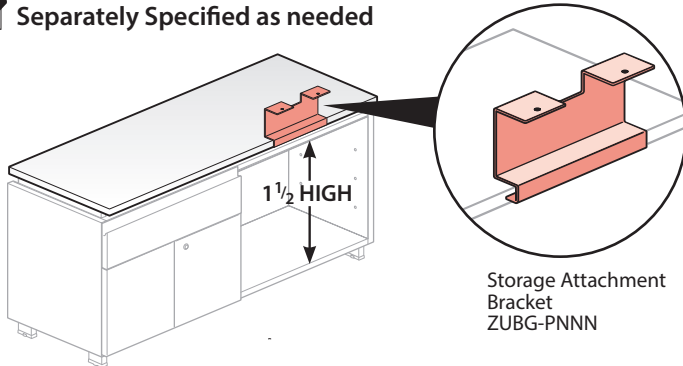

- Provides support for Base Units with drawers.
- Does not provide support to the worksurface.

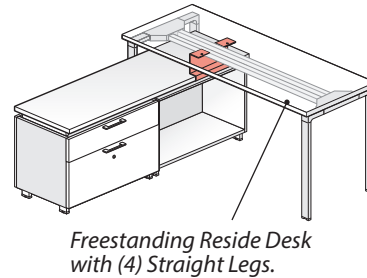

- Note**
- Storage Attachment Bracket does not provide Beside Worksurface support.
 - In a benching application with One and One-Half Base Units perpendicular to a 24" depth worksurface the Base Unit must be located 6" for the back of the Worksurface to accommodate the Storage Attachment Bracket. This guideline applies to a 24" deep Worksurface, only.

Flush Mount Plate

Separately specified Flush Mount Plates are required for the following application:

- In a Two-High Storage Based Planning Model (Base Units function as application spine): Beside Worksurfaces are located perpendicular to the storage spine.
- Two Flush Mount Plates attach to the top of a two-high Base Unit providing Beside Base Unit and Beside Worksurface required support.

☑ Separately Specified as needed

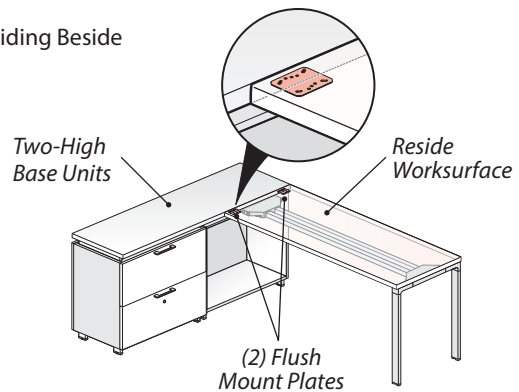
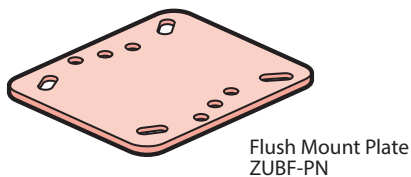

- Note**
- Beside Return Worksurfaces cannot be attached to a Beside Base Unit; applies to all Base Unit heights.

Ganging Bracket Kit

- Ganging Bracket Kit includes two brackets, one for in-line storage planning model and one flat bracket for back to back planning Model.
- Gangs two Base Units together back to back or in-line.

☑ Separately Specified as needed

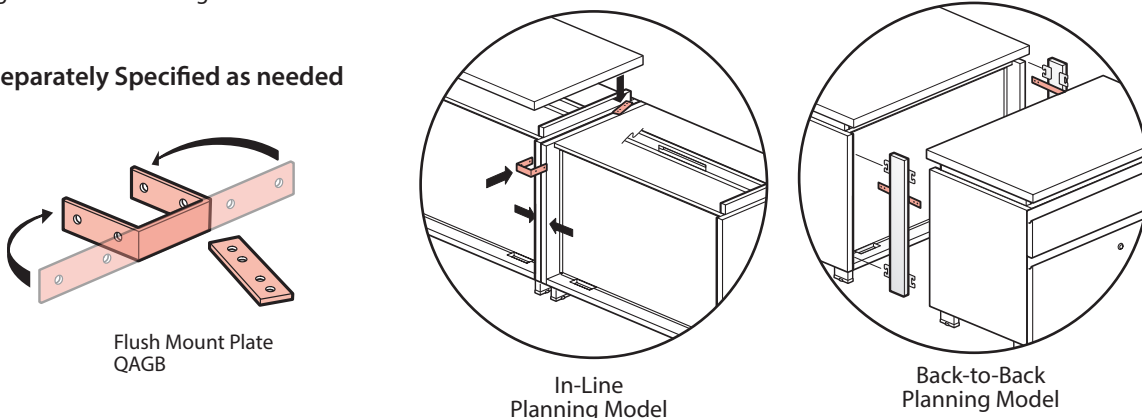

Product Details – Beside Storage



Electrical Components

Infeed Harness

IN: Power to Beside Storage

The Infeed Harness is used to transition building wiring to modular power within the furniture. One end is hardwired to the building wiring and the modular end snaps into the Power Distribution Assembly (PDA) in the furniture. This connection may be used to bring power in from the base.

Specification Tips

- For use with 30"–72" (762mm–1829mm) wide power components.
- Modular connector plugs into receptacle or power connector site on PDA.

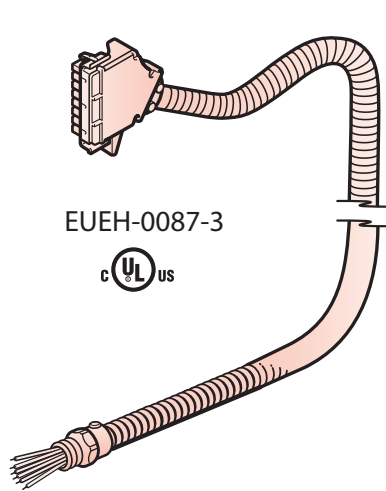

POWER LOCATIONS

- Floor
- Column
- Wall

Circuit	Lengths
3-Circuit	87"
	180"
	300"
4-Circuit (2+2)	87"
	180"
	300"
4-Circuit (3+1)	87"
	180"
	300"

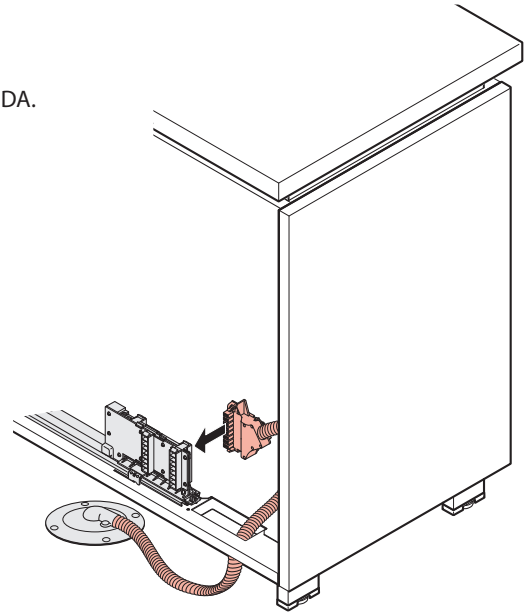

Infeed Harness Application

Internal Power Base AI Base Feed

IN: Power to Beside Storage

These modules are used to make plug-and-play connections between Power Base AI under floor modular power and Power Base modular power in furniture.

Specification Tips

- For use with 30"–72" wide power components.
- Can only be connected to Power Base AI underfloor power system.
- Black split tubing may be field supplied to cover any galvanized metal conduit.
- Attaches at receptacle or power connector site in PDA and to a Power Base AI underfloor power system.

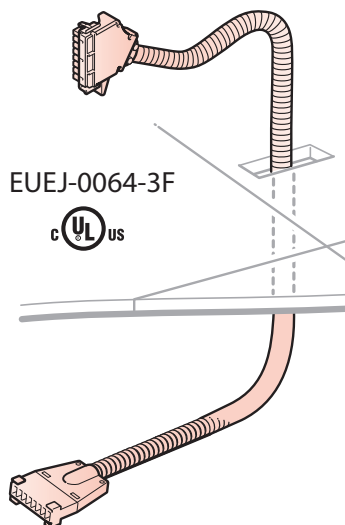

POWER LOCATION

- Floor

Circuit	Lengths
3-Circuit	64"
	144"
	300"
4-Circuit (2+2)	64"
	144"
	300"
4-Circuit (3+1)	64"
	144"
	300"

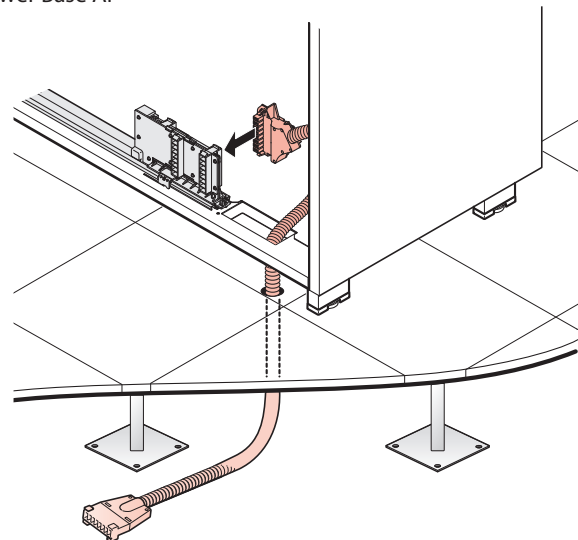

Internal Power Base AI Base Feed Application

Product Details – Beside Storage



Electrical Components

Base Feed Module: Architectural Concealed Hardwire Connection

IN: Power to Beside Storage

The module is used to transition building wiring to modular power within the furniture. The module's junction box is mounted to the furniture and its modular connector snaps into the power distribution assembly (PDA).

Specification Tips

- Attaches to PDA on Beside Storage Base Units 42" and wider.
- Attaches to the side on 30" and 36" wide Base Units that are 1½ high or 2 high.
- Modular connector plugs into a receptacle site on PDA.
- Conforms to New York City Electrical Code.

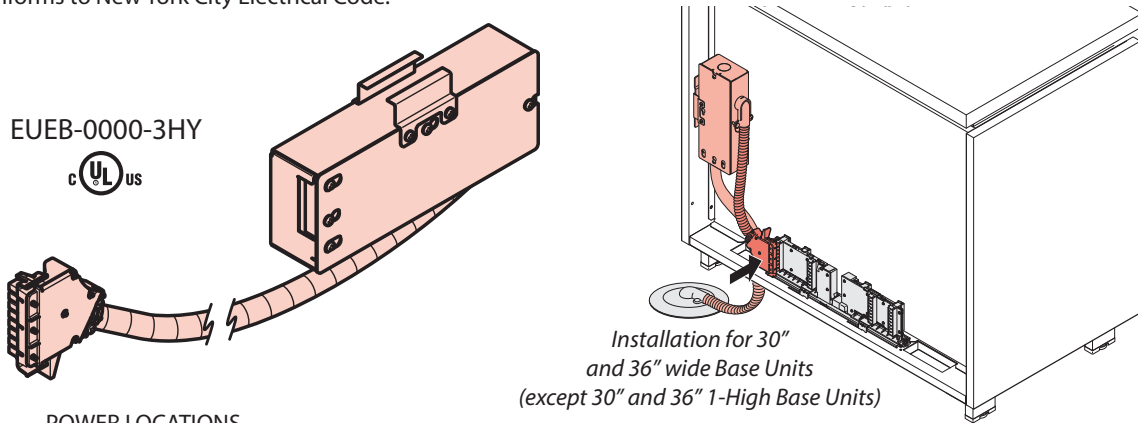

EUEB-0000-3HY

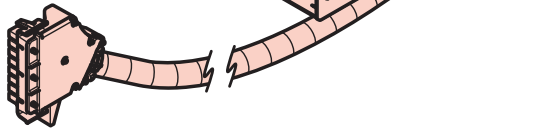

Installation for 30" and 36" wide Base Units (except 30" and 36" 1-High Base Units)

POWER LOCATIONS

- Floor
- Column
- Wall

Circuit

- 3-Circuit
- 4-Circuit (2+2)
- 4-Circuit (3+1)

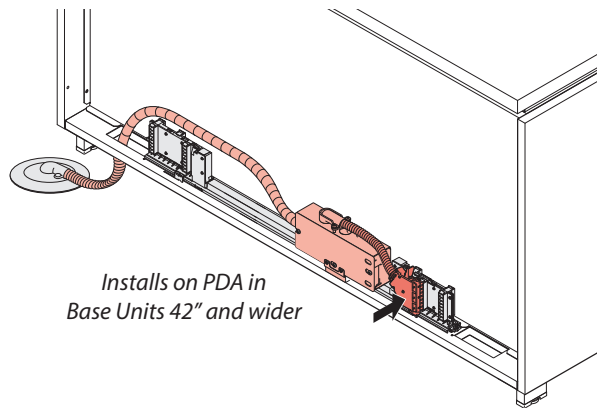

Installs on PDA in Base Units 42" and wider

Product Details – Beside Storage



Electrical Components

Top Feed

IN: Power to Beside Storage

The module mounts to a Beside Storage Base Unit along the end, back or to the top and routes power and communications cabling from the ceiling to the PDA in the furniture.

Specification Tips

- For use with 30"–72" (762mm–1829mm) wide Base Units.
- Mounts at the end, back or to the top of a Beside base storage unit.
- Wire harness length is 180" (4572mm) regardless of pole length.
- Top Feed Grommet requires 12" minimum clearance to mount to top of Beside Storage Top.

Circuit	Ceiling Height	Pole Length
3-Circuit	10'	138"
	12'	150"
4-Circuit (2+2)	10'	138"
	12'	150"
4-Circuit (3+1)	10'	138"
	12'	150"
Hardwire	10'	138"
	12'	150"

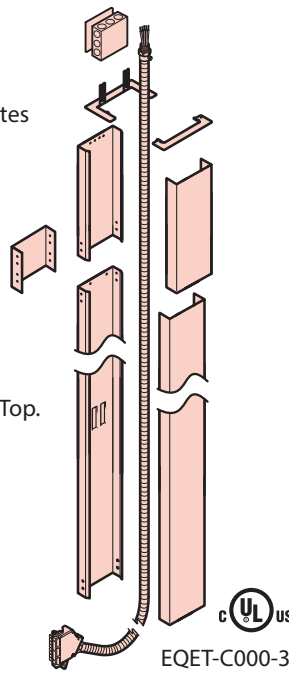

POWER LOCATION
• 10' and 12' Ceilings

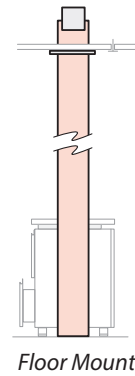

Floor Mount

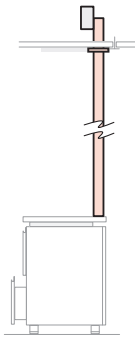

Top Mount with Top Feed Grommet

Top Feed Grommet

- Separately Specified
- Beside Storage Only

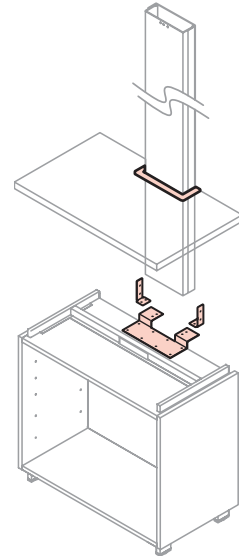

EQAG-0000-PT

Do

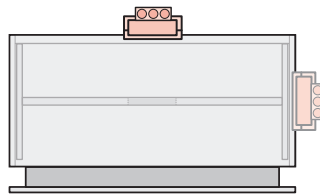

Front

For a Single Sided Storage application, the top feed mount may attach to the back of the Base Unit or to the side of the Base Unit at an end-of-run condition. If using Belong Screens and/or rails allow for proper space allocation to accommodate the top feed.

Note

Do

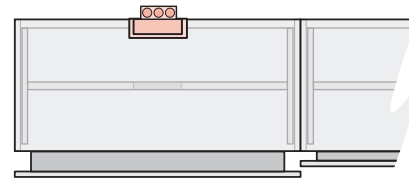

Front

If the Top Feed is attached to a Storage Top with the use of a Top Feed Grommet and the Top Feed Pole. More than one Base Unit must be ganged together when the Top Feed is attached to the Storage Top.

Do

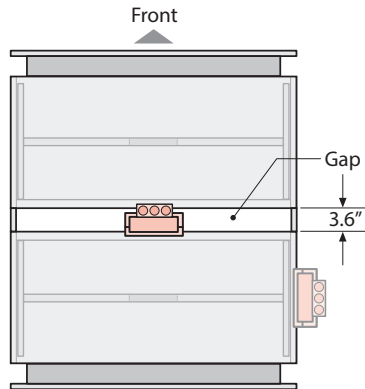

Front

In a Double Sided storage application with a 3.6" gap, the top feed may attach to the back of the Base Unit or to the side of the Base Unit at an end-of-run condition.

Do

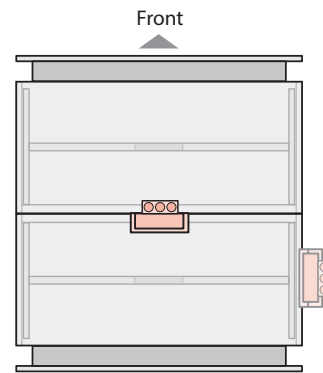

Front

In a Double Sided storage application with no gap, the top feed may attach to the top of the Storage Top with a separately specified Grommet and at the end-of-run condition.

Note

If using Belong Screens and/or Rails allow for proper space allocation to accommodate the Floor Mount Top Feed.

Product Details – Beside Storage



Electrical Components

Power Distribution Assembly (PDA)

THROUGH: Power Distribution

A Power Distribution Assembly (PDA) is used to distribute power through the furniture. The PDA is used to connect electrical components such as in-feeds, jumpers, and power taps. The PDA has eight connection sites for the purpose of attaching these components. Receptacles cannot be attached to a PDA in a Beside Storage Base Unit, instead Power Taps should be utilized to access power.

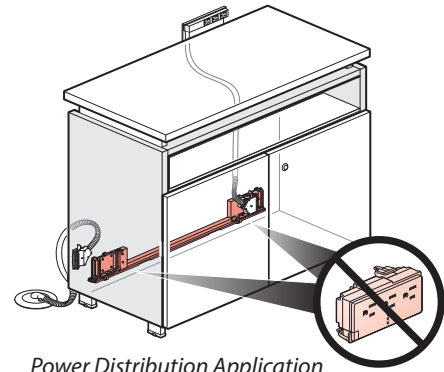

Power Distribution Application

Specification Tips

- For use with 30"–72" (762mm–1829mm) wide Beside Storage Base Units.
- Match PDA width to storage width.
- One PDA cannot span multiple Base Units.
- Specify appropriate jumper when spanning power between powered storage or powered worksurfaces.
- A non-powered storage Base Unit can be powered with the addition of the Power Distribution Assembly (PDA).
- 24" wide Base Units do not accept power. A 76" Jumper must be used to pass power through a 24" Base Unit located between two powered Base Units in an in-line application.

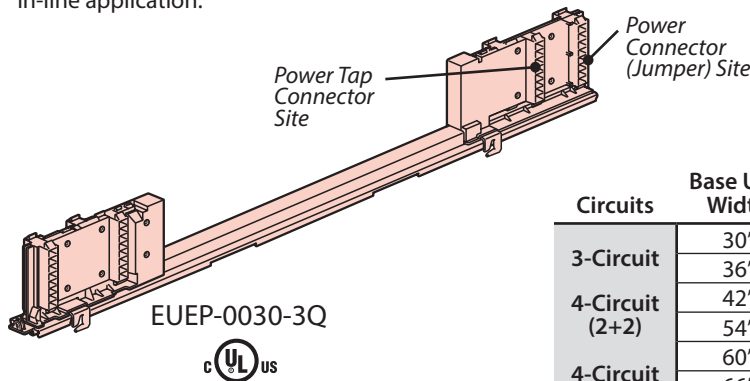

Circuits	Base Unit Width
3-Circuit	30"
	36"
4-Circuit (2+2)	42"
	54"
4-Circuit (3+1)	60"
	66"
	72"

Jumpers – Power Connectors

THROUGH: Power Distribution

These connectors are used to span power between Power Distribution Assemblies mounted in Beside Storage Base Units and/or between powered units (desk to desk / storage to storage / desk to storage / storage to desk). A Power Distribution Assembly (PDA) is separately specified to match the size of each storage unit.

Specification Tips

- Connectors cannot be coupled together.
- Jumpers are sized specific to the application.
- Jumpers can be used to pass through non-powered Base Units.
- A 76" jumper must be used to pass power through a 24" Base Unit located between two powered Base Units in an in-line application.

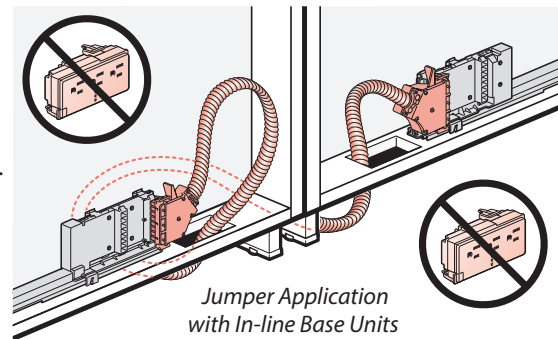

Jumper Application with In-line Base Units

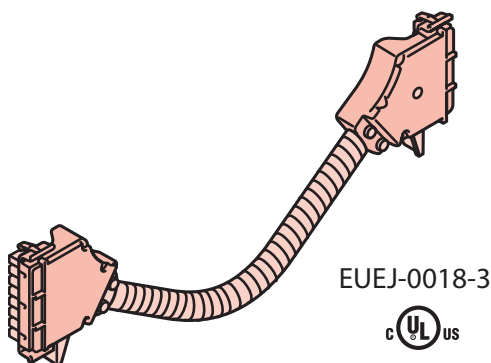

Circuits	Lengths
3-Circuit	42"
	48"
4-Circuit (2+2)	54"
	60"
4-Circuit (3+1)	76"
	96"

Note • For use with Reside Desking and Beside Storage only.

Product Details – Beside Storage



Electrical Components

Jumper – Application Guidelines

THROUGH: Power Distribution

- Separately specified Jumpers are used to distribute power from one powered storage unit to another.
- Jumper length for in-line Base Units with single sided access is 42".

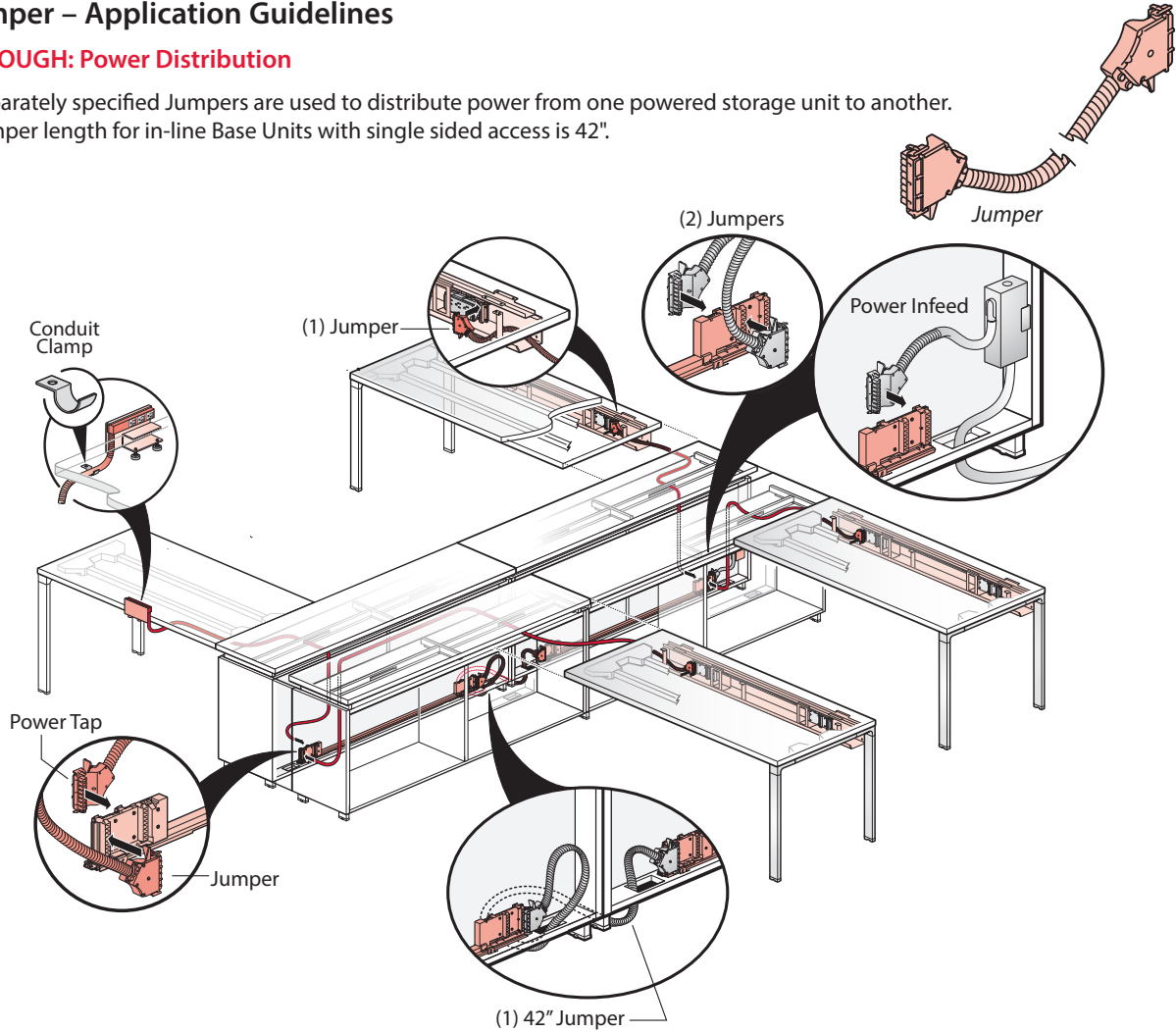

A 42" Jumper must be used to pass power between 48" Base Units in an in-line application.

24" wide Base Units do not accept power. A 76" Jumper must be used to pass power through a 24" Base Unit located between two powered Base Units in an in-line application.

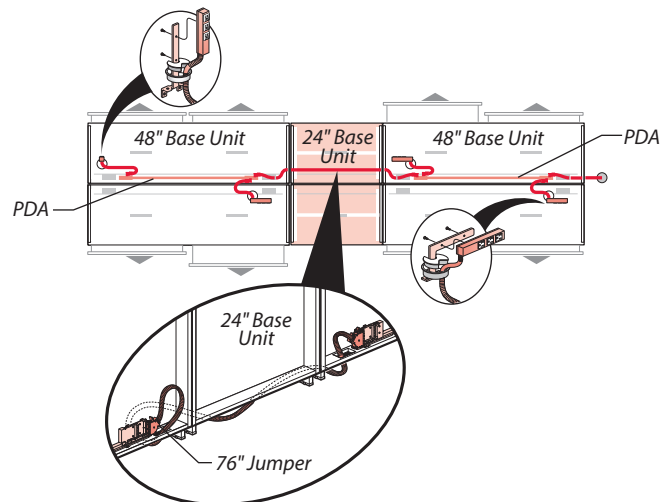
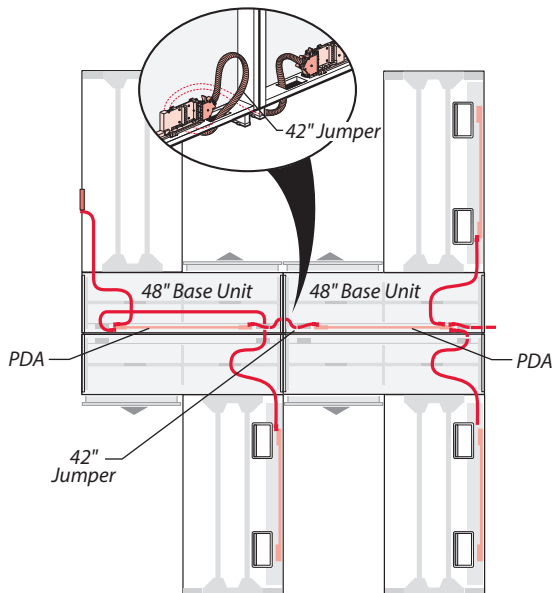

Product Details – Beside Storage



Electrical Components

Jumper – Application Guidelines

THROUGH: Power Distribution

- Separately specified jumpers are used to distribute power from one powered storage unit to another.
- Jumper length for in-line Base Units with dual sided access is 54".
- Jumper length to pass power through a 24" Non-Powered Base Unit located between two powered Base Units in an in-line application is 76".

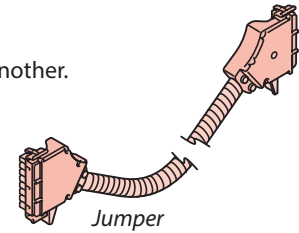

Recommended Jumper Lengths for dual sided in-line Base Units Applications:

A 54" Jumper must be used to pass power through in-line Base Units with dual sided access.

24" wide Base Units do not accept power. A 76" Jumper must be used to pass power through a 24" Base Unit located between two powered Base Units in an in-line application.

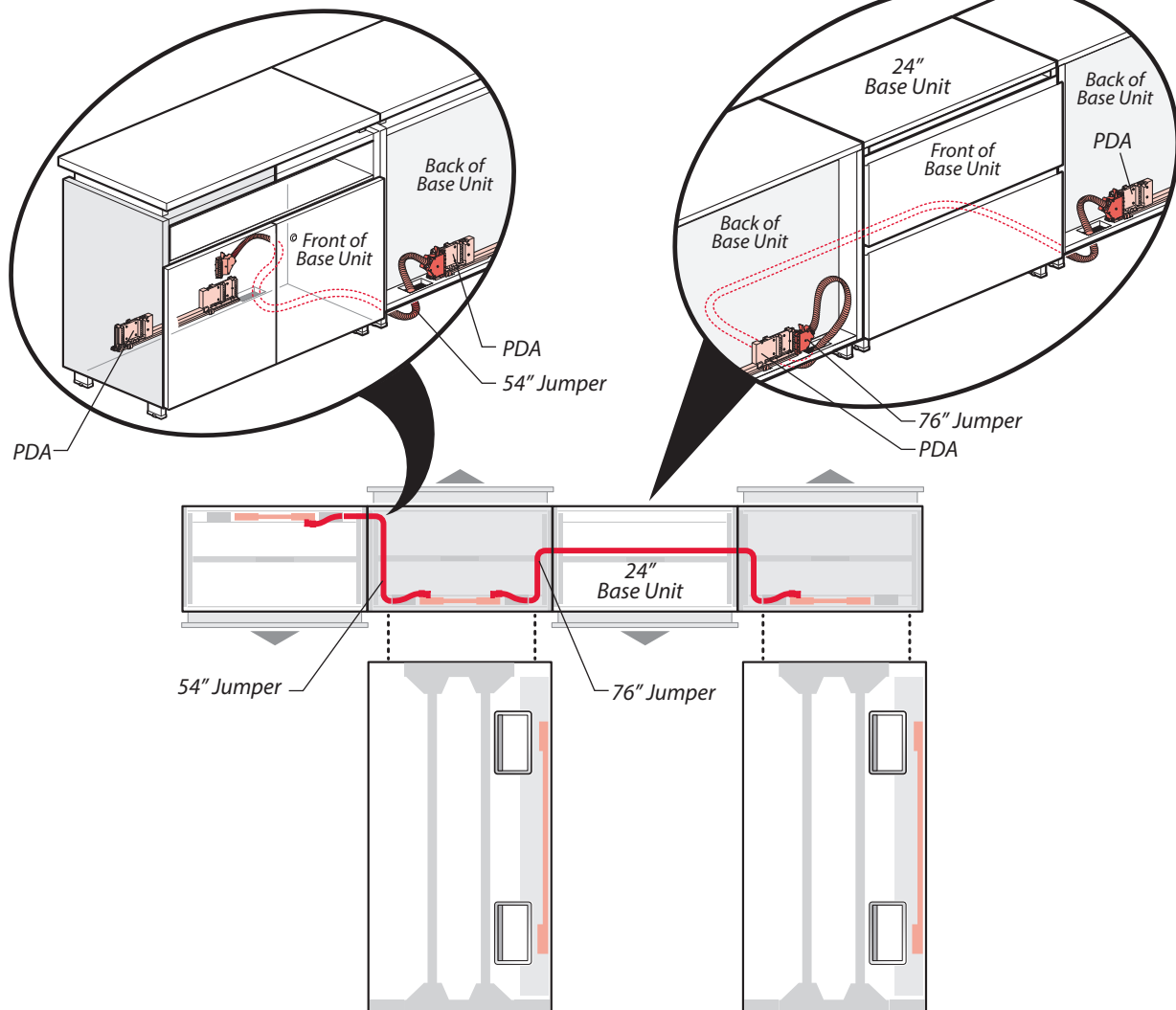

Product Details – Beside Storage



Electrical Components

Calculating Jumper Length – Beside Storage to Reside Worksurface with Utility Tray

THROUGH: Power Distribution

Jumper length run from a 1½ High and 2 High Base Units to a Reside Worksurface with Utility Tray is 96" or 144".

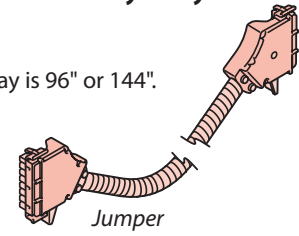

Recommended Jumper Lengths for routing power from Beside Base Units with PDAs to Reside Worksurfaces with powered Utility Trays:

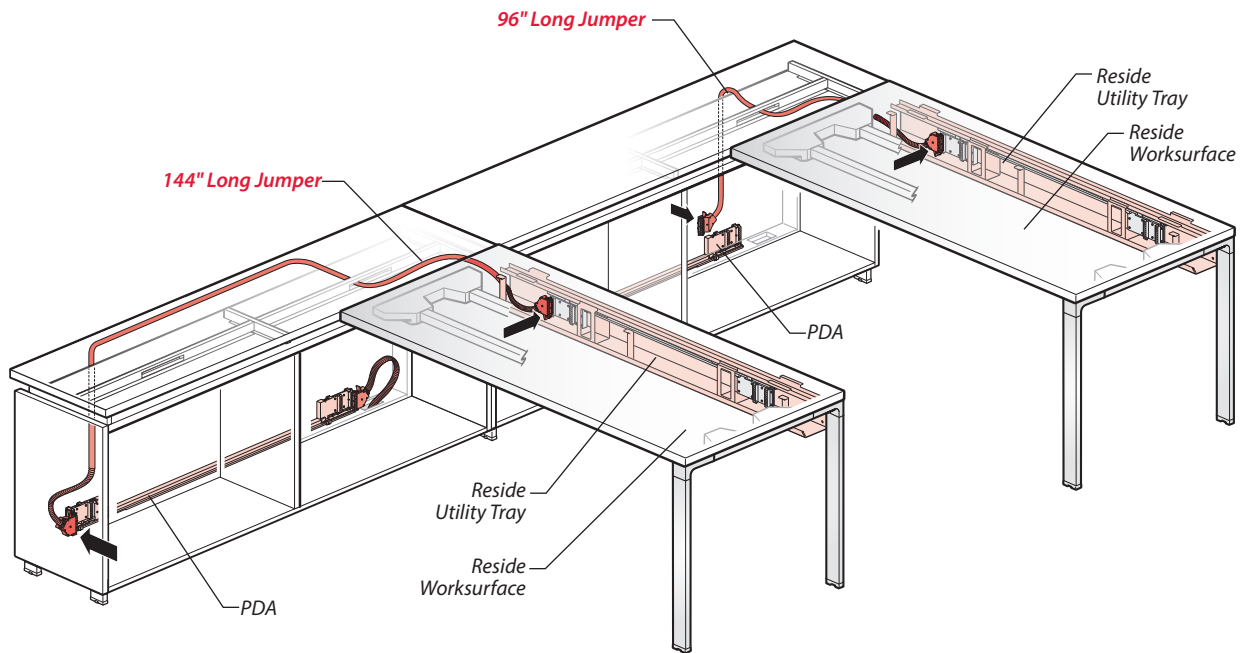

Product Details – Beside Storage



Electrical Components

Power Taps

OUT: Receptacle Access

- Power Taps provide three 15A receptacle outlets in a housing that can attach to a separately specified Power Tap Bracket. Power Tap Brackets can be mounted through Storage Tops with grommets, to the back edge of a single sided storage application or in a double storage applications with 2.8" and 5.1" Filler Panels without Stanchion Kits.

Specification Tips

- 15 Amp receptacle configuration is NEMA 5-15R.
- Specify appropriate number of Power Taps for each circuit.
- Required Mounting Bracket is separately specified.
- Available in conduit and hardwire versions only for Beside Storage.
- Power Tap applications should be reviewed by local authorities (electrical inspector) prior to ordering due to varying local codes.
- Power Tap modular connector heads are handed.

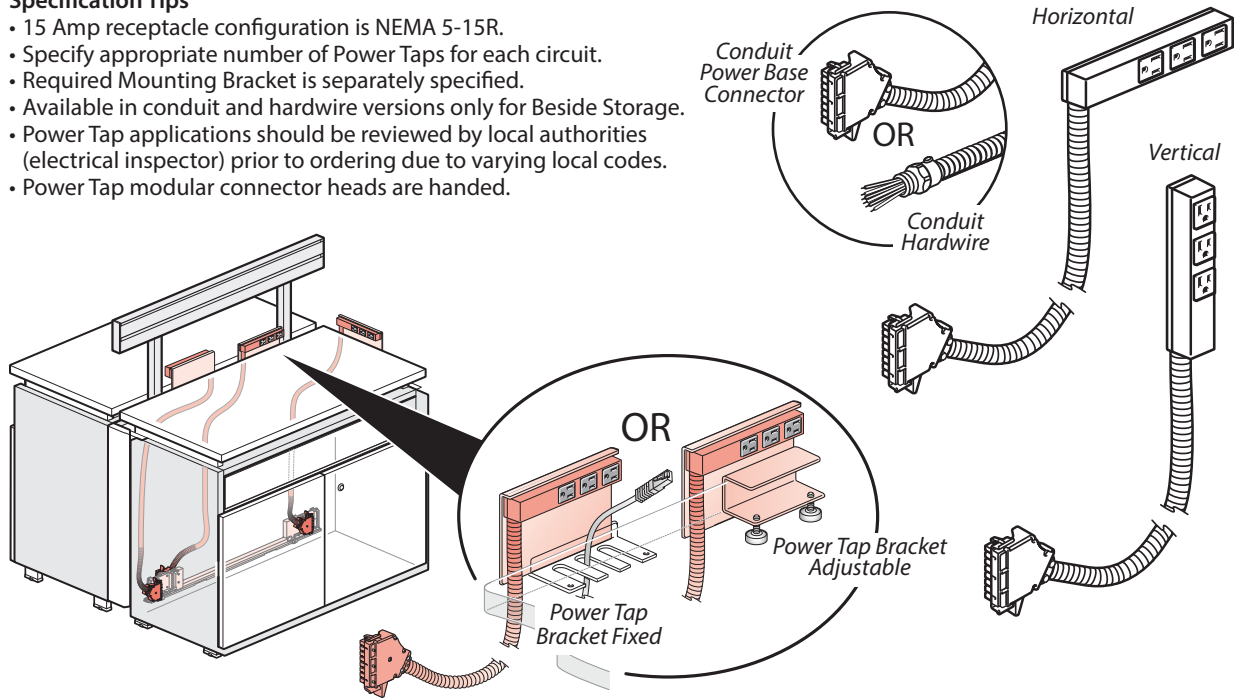

Power Tap Brackets

ACCESSORIES: Wire Management

- Power Taps require a separately specified Power Tap Brackets to attach to Beside Storage Base Units.
- Power Tap Bracket types – with Grommet (Vertical and Horizontal), Fixed, or Adjustable

Power Tap Brackets With Grommet – Vertical / Horizontal

- Power Tap Bracket with Grommet – Horizontal and Vertical are specified for:
 - Single sided storage applications with or without Stanchion Kits.
 - Double sided storage applications with or without Stanchion Kits.
- Power Tap Bracket with Grommet – Horizontal mounts to Beside Storage Top through field installed grommet. Horizontal Power Tap required.
- Power Tap Bracket with Grommet – Vertical mounts to Beside Storage Top through field installed grommet. Vertical Power Tap required.
- Always use Power Tap Bracket with Grommet if Stanchion Kit(s) block access to back edge of Storage Top(s).

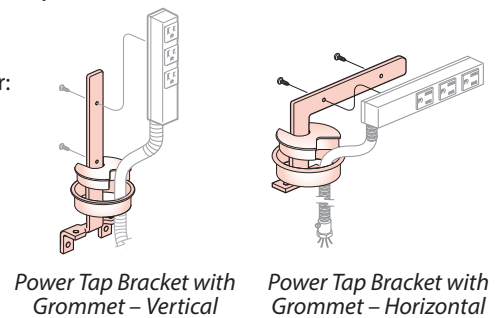

Power Tap Brackets – Fixed / Adjustable

- Power Tap Bracket – Fixed and Adjustable are specified for:
 - Single sided storage applications.
 - Double sided storage applications with 2.8" and 5.1" Filler Panels without Stanchion Kits.
- Power Tap Bracket – Fixed and Adjustable mount to back edge of Storage Top(s). Horizontal Power Tap required.
- Power Tap applications should be reviewed by local authorities (electrical inspector) prior to ordering due to varying local codes.

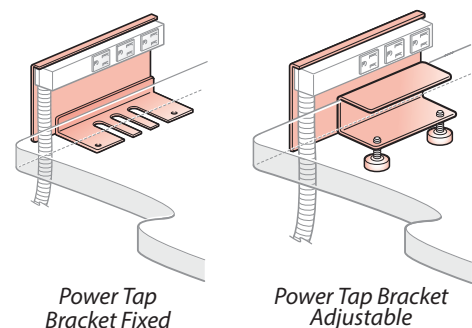

Product Details – Beside Storage



Electrical Components

Power Tap and Power Tap Bracket Guidelines

OUT: Receptacle Access – Power Tap and Power Tap Bracket Guidelines

Do For power access in Beside Storage applications with stanchions only the Power Tap (vertical or horizontal) and corresponding Power Tap Bracket with Grommet (vertical or horizontal) can be used.

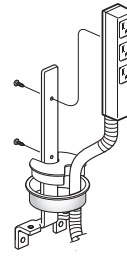
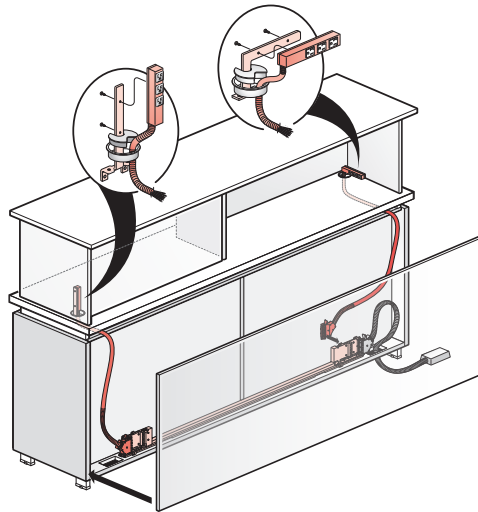

Power Tap – Vertical and Power Tap Bracket with Grommet – Vertical

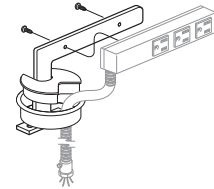

Power Tap – Horizontal and Power Tap Bracket with Grommet – Horizontal

Do When planning with Power Tap Brackets in benching or desking and storage based applications make certain that there are no clearance or mounting issues with other Electrical Components, Tool Rail Mounts, Center or Back Screen Mounts or Worksurface Support Components.

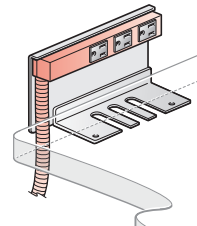
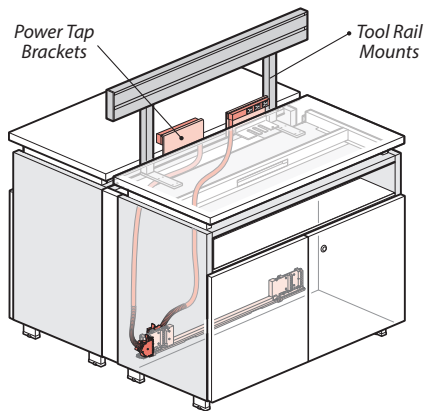

Power Tap – Horizontal and Power Tap Bracket Fixed

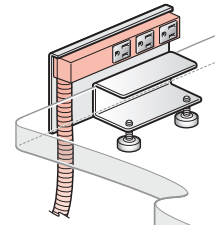

Power Tap – Horizontal and Power Tap Bracket Adjustable

Do The Power Tap – Vertical and the Power Tap Bracket – Under Surface may be used to access power inside Base Units.

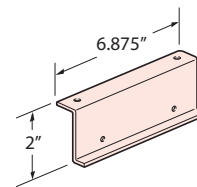
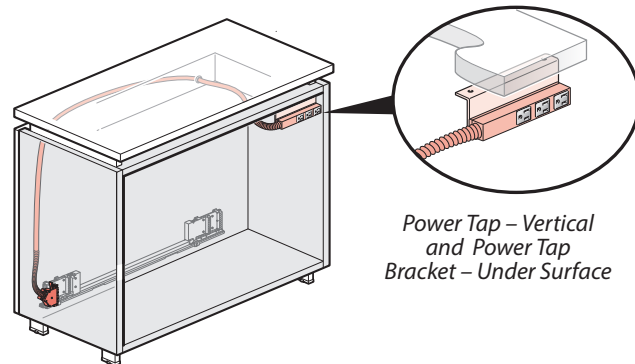

Power Tap Bracket – Under Surface

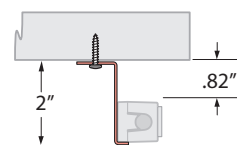

Power Tap – Vertical and Power Tap Bracket – Under Surface

Product Details – Beside Storage



Electrical Components

Calculating Power Tap Reach – Beside Storage to Reside Worksurface with Power Tap Bracket

OUT: Receptacle Access

Refer to the chart below to determine the reach of each power tap to determine possible worksurface locations. The chart applies to 6' and 9' Power Taps.

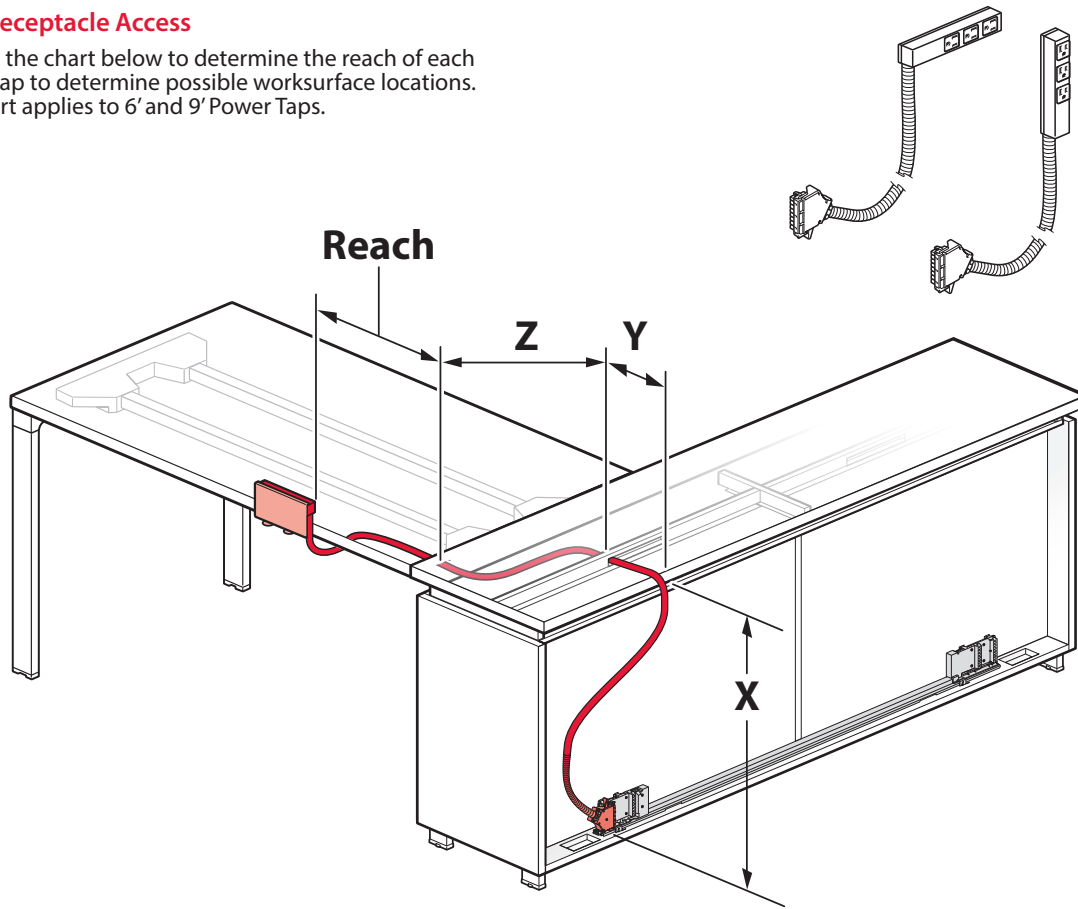

Reach (Adjustment Range of Power Tap from the edge of the Worksurface)

Storage Height	Storage Width	Dimension X	Dimension Y	Dimension Z	Total Inches To Front Corner	Reach of 6' Power Tap	Reach of 9' Power Tap
1 1/2 High and 2 High	24"	30"	15"	15"	60"	6"	42"
1 1/2 High and 2 High	30"	30"	18"	18"	66"	0"	36"
1 1/2 High and 2 High	36"	30"	20"	20"	70"	NO	32"
1 1/2 High and 2 High	42"	30"	23"	23"	76"	NO	26"
1 1/2 High and 2 High	48"	30"	15"	15"	60"	6"	42"
1 1/2 High and 2 High	54"	30"	18"	18"	66"	0"	36"
1 1/2 High and 2 High	60"	30"	20"	20"	70"	NO	32"
1 1/2 High and 2 High	66"	30"	23"	23"	76"	NO	26"
1 1/2 High and 2 High	72"	30"	26"	26"	82"	NO	20"

Product Details – Beside Storage

Electrical Components

Typical Conduit Routing For Beside Storage / Reside Desking Applications

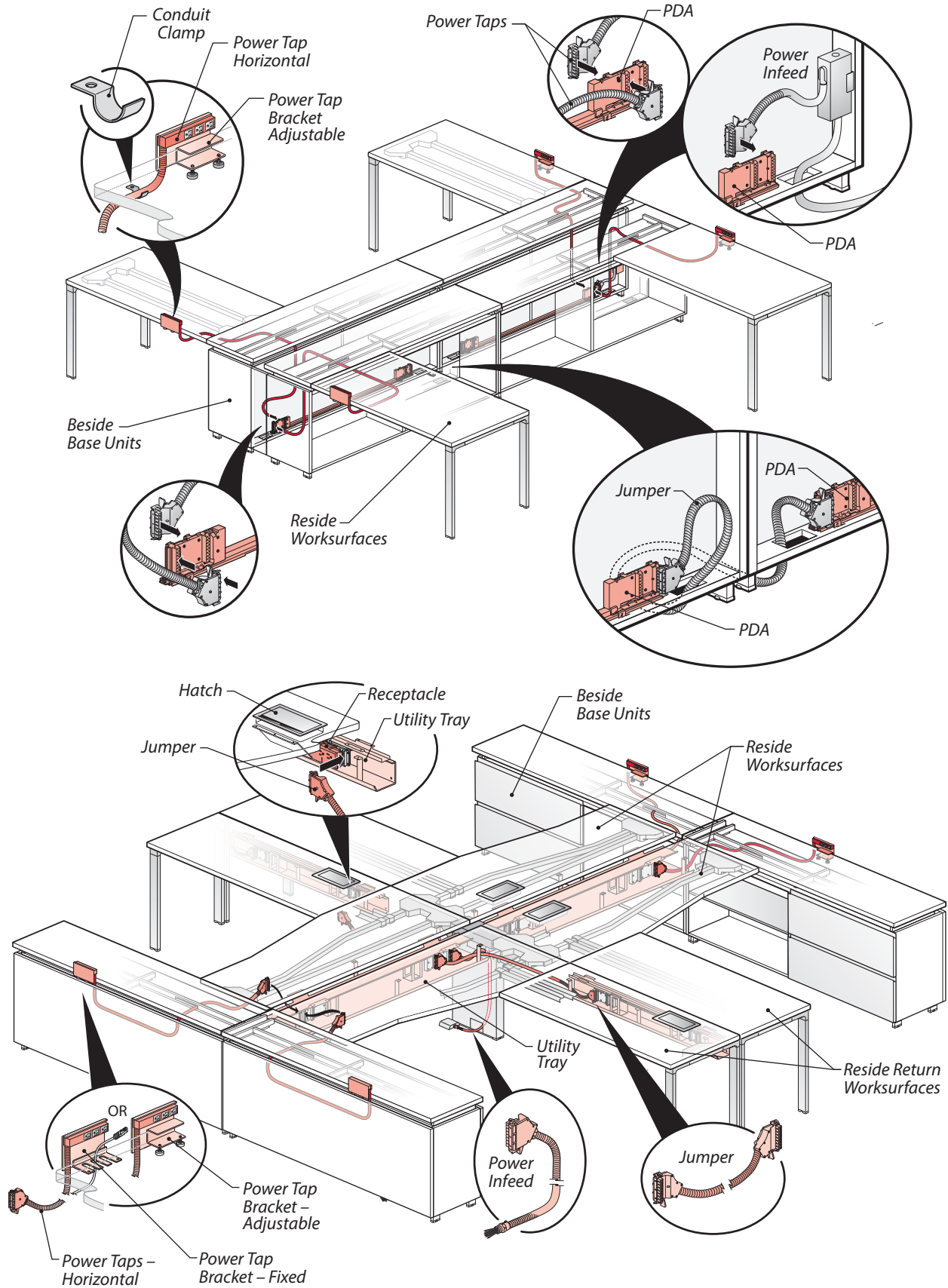

Product Details – Beside Storage

Stanchion Kit – Configurations

- Stanchion Kits are available in six heights 10", 11", 12", 15", 16", 18".
- Widths are determined per kit type, 24", 30", 36", 42", 48", 54", 60", 66", and 72".
- The Stanchion configuration determines the amount of enclosure and the inclusion of accessory slots for Belong accessories.

Catalog logic drives the **Stanchion configuration**. Configurations can be open, partially enclosed or fully enclosed. Each configuration is available with or without a division.

Catalog Logic:

Product/Catalog Number:
QUSS-1036-PEA
Configuration →

- G – Open
- H – Open with Division
- M – Partial Enclosure
- N – Partial Enclosure with Division
- P – Full Enclosure
- Q – Full Enclosure with Division

Open Configuration – Stanchion Kits:

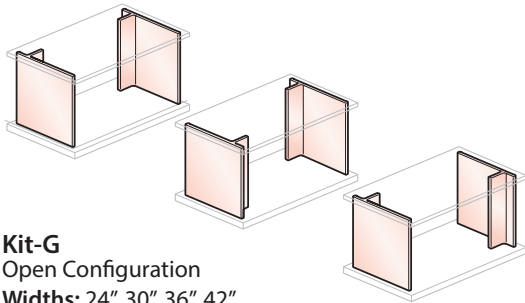

Kit-G
Open Configuration
Widths: 24", 30", 36", 42"

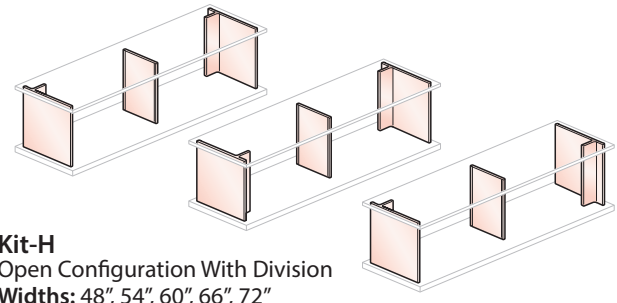

Kit-H
Open Configuration With Division
Widths: 48", 54", 60", 66", 72"

Note Open configuration Stanchion Kits (Kit-G and Kit-H) are not available with accessory slots.

Partial Enclosure Configuration – Stanchion Kits:

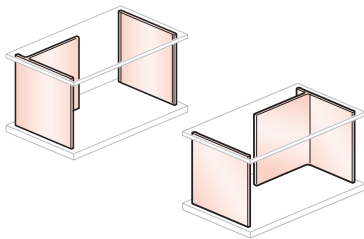

Kit-M
Partial Enclosure Configuration
Widths: 24", 30", 36", 42"

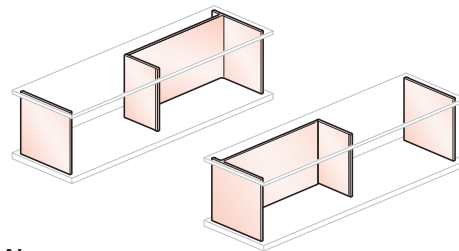

Kit-N
Partial Enclosure Configuration With Division
Widths: 48", 54", 60", 66", 72"

Note Partial enclosure configuration Stanchion Kits (Kit-M and Kit-N) are available with or without accessory slots. Refer to price list for details.

Full Enclosure Configurations – Stanchion Kits:

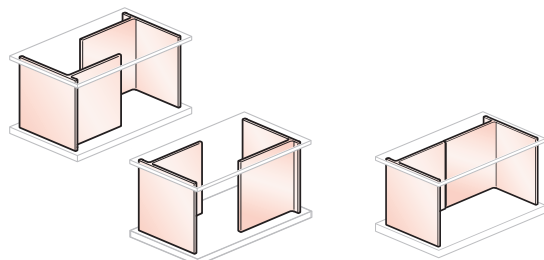

Kit-P (Mirror Image Application)
Full Enclosure Configuration
Widths: 24", 30", 36", 42", 48", 54", 60", 66", 72"

Kit-P (In-line Application)
Full Enclosure Configuration
Widths: 24", 30", 36", 42"

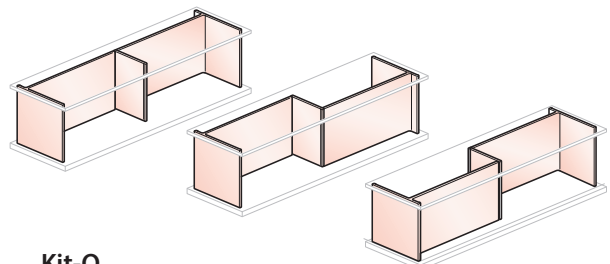

Kit-Q
Full Enclosure Configuration With Division
Widths: 48", 54", 60", 66", 72"

Note

- Stanchion Kit P can be applied in an in-line condition up to 42". Greater than 42" requires the product to be installed in a mirror image application only.
- Full enclosure configuration Stanchion Kits (Kit-P and Kit-Q) are available with or without accessory slots. Refer to price list for details.

Product Details – Beside Storage

Stanchion Kits – Application Guidelines

Stanchion Kit applications consist of separately specified components: Base Unit, Storage Top, Stanchion Kit and Hutch Shelf or Overhead Storage Unit .

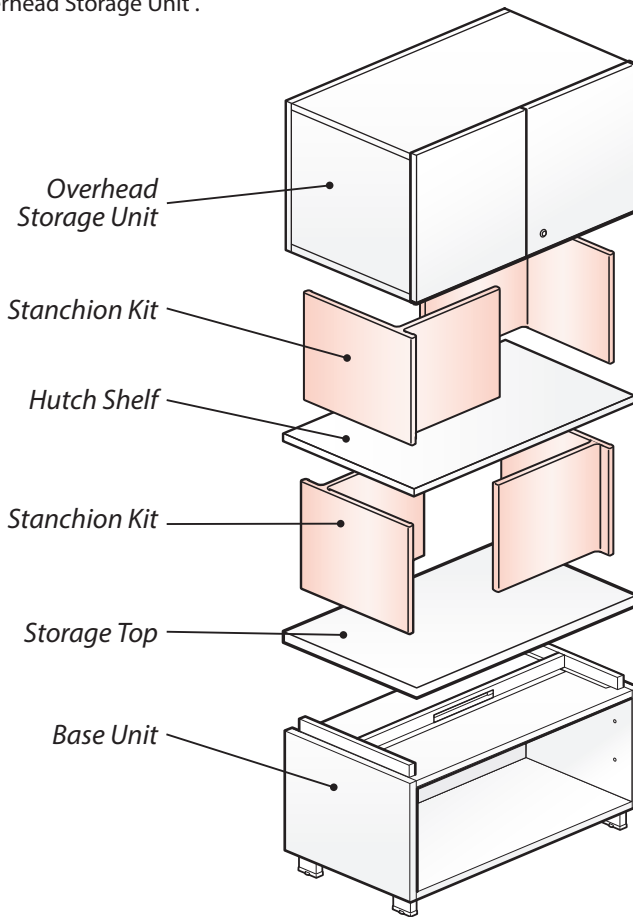

- Stanchion Kits include vertical Stanchion panels and attachment hardware
- All kits have a left and a right Stanchion. Select kits have a center Stanchion.
- Stanchion Kits are for use on Base Units with Storage Top, only.
- Hutch Shelf , Stanchion Kits and Overhead Storage Unit applications must not exceed 58" in height.

Accessory Slot Functionality

- Stanchion Kits slots may be specified for user side access or access on both sides.
- For accessory slot functionality per Stanchion Kit type refer to the price list for detailed product offering.
- Belong tools may be separately specified for Stanchion Kits if specified with accessory slots.

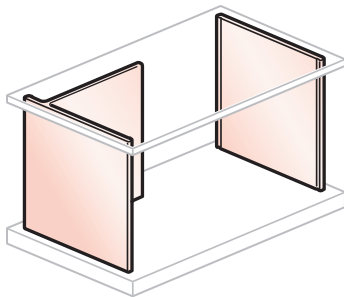

No Accessory Slots

- Not for use with Belong accessories.

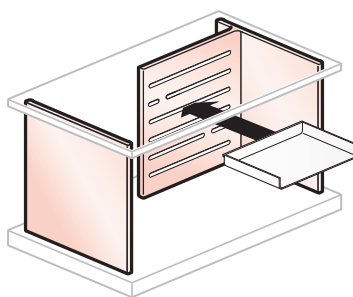

User Side Accessory Slots

- For use with separately specified Belong accessories.
- Right hand Stanchion is shown with user sided accessory slot option. Provides single user accessory access.

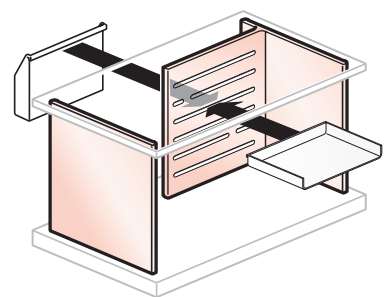

Both Sided Accessory Slots

- For use with separately specified Belong accessories.
- Right hand Stanchion is shown with both sided accessory slot option. Provides dual user accessory access.

Note Verify Stanchion height will accommodate needed accessories and tools.

Product Details – Beside Storage

Stanchion Kits – Specifying Accessory Slot Functionality

- Stanchion Kits with the accessory slot functionality offer multiple slot locations ranging from left side, right side or both sides.
- Slots may be specified for user side access or access on both sides.
- For available width and accessory functionality refer to the price list for detailed product offering.

Catalog Logic:

Product/Catalog Number:
QUSS-1036-PE^A
Accessory Functionality ← **A**

Catalog logic drives **accessory slot** location for fully enclosed (kit-P and kit-Q) and partially enclosed (kit-N and kit-M) Stanchion Kit configurations. Open configurations (kit-H and kit-G) are not available with accessory slots.

Open Configuration – Kit-H and Kit-G

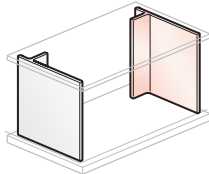

N No Slots

Note Open configuration Stanchion Kits (Kit-G and Kit-H) are not available with accessory slots.

Full Enclosure Configuration – Kit-P and Kit-Q

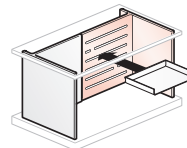

A User sided accessory slot for right hand Stanchion.

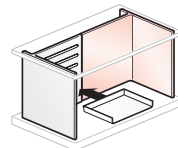

B User sided accessory slot for left hand Stanchion.

Partial Enclosure Configuration – Kit-N and Kit-M

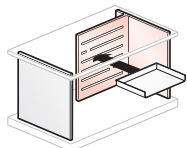

A User sided accessory slot for right hand Stanchion.

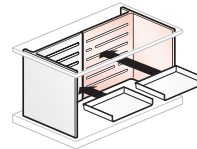

C User sided accessory slot for right and left hand Stanchion.

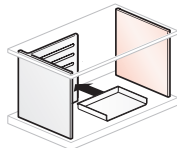

B User sided accessory slot for left hand Stanchion.

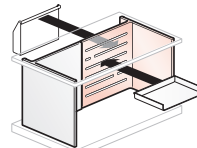

D Both side accessory slot for right hand Stanchion.

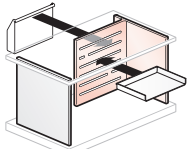

D Both side accessory slot for right hand Stanchion.

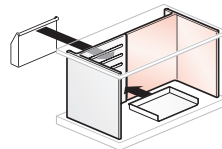

E Both side accessory slot for left hand Stanchion.

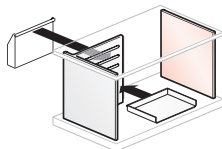

E Both side accessory slot for left hand Stanchion.

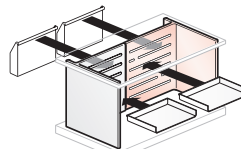

F Both sided accessory slot for right and left hand Stanchion.

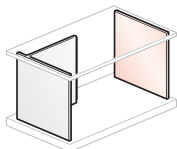

L No accessory slot for left hand Stanchion.

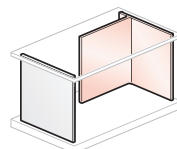

R No accessory slot for right hand Stanchion.

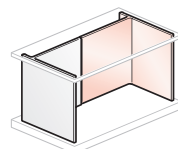

N No Slots

- Tip**
- Back panel determines handedness of accessory slot functionality.
 - Installation drawings must depict Stanchion Kit orientation and color selection to ensure design intent.

Product Details – Beside Storage

Stanchion Kits – Accessory Slot Dimensions – 24" Wide Stanchions

• Stanchion Accessory Slots may be used to accommodate separately specified Belong hanging accessories.

Belong Hanging Accessories – Dimensions

Paper Tray – Landscape

• May be mounted on Stanchion Accessory Slots larger than 12 3/4" wide.

Height	Depth	Width
1 1/2"	8 7/8"	12 3/4"

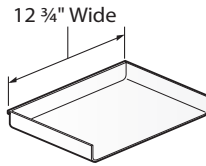

Mini Shelf

• May be mounted on Stanchion Accessory Slots larger than 8" wide.

Height	Depth	Width
1"	4"	8"

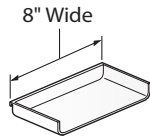

Tool Cup

• May be mounted on Stanchion Accessory Slots larger than 2 1/2" wide.

Height	Depth	Width
3 1/2"	2 1/2"	2 1/2"

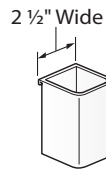

Hanging Sorter

• May be mounted on Stanchion Accessory Slots larger than 12 3/4" wide.

Height	Depth	Width
8 1/2"	2 1/2"	12 3/4"

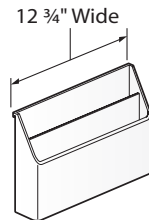

Reference Shelf – Small

• May be mounted on Stanchion Accessory Slots larger than 6 3/8" wide.

Height	Width
11 1/4"	9 7/8"

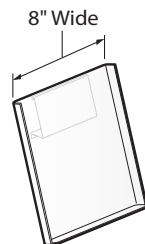

Reference Shelf – Large

• May be mounted on Stanchion Accessory Slots larger than 14 3/4" wide.

Height	Width
11 1/4"	18 1/2"

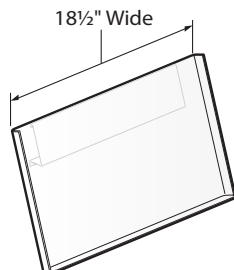

24" Wide Stanchions –

• Stanchion Kit-P shown with Mirror Image Application
 • Dimensions are typical for All 24" partial and full enclosure Stanchion Kits (configurations/orientations may vary).

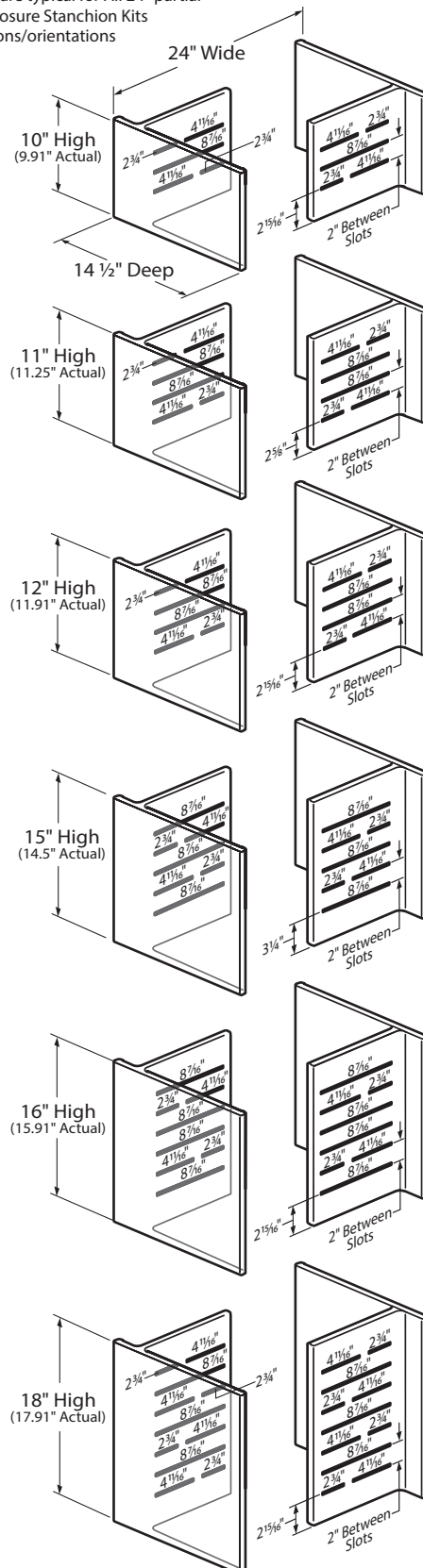

Product Details – Beside Storage

Stanchion Kits – Accessory Slot Dimensions – 30" and 46" Wide Stanchions

• Stanchion Accessory Slots may be used to accommodate separately specified Belong hanging accessories.

30" Wide Stanchions –

- Stanchion Kit-P shown with Mirror Image Configuration.
- Dimensions are typical for All 30" partial and full enclosure Stanchion Kits (configurations/orientations may vary).

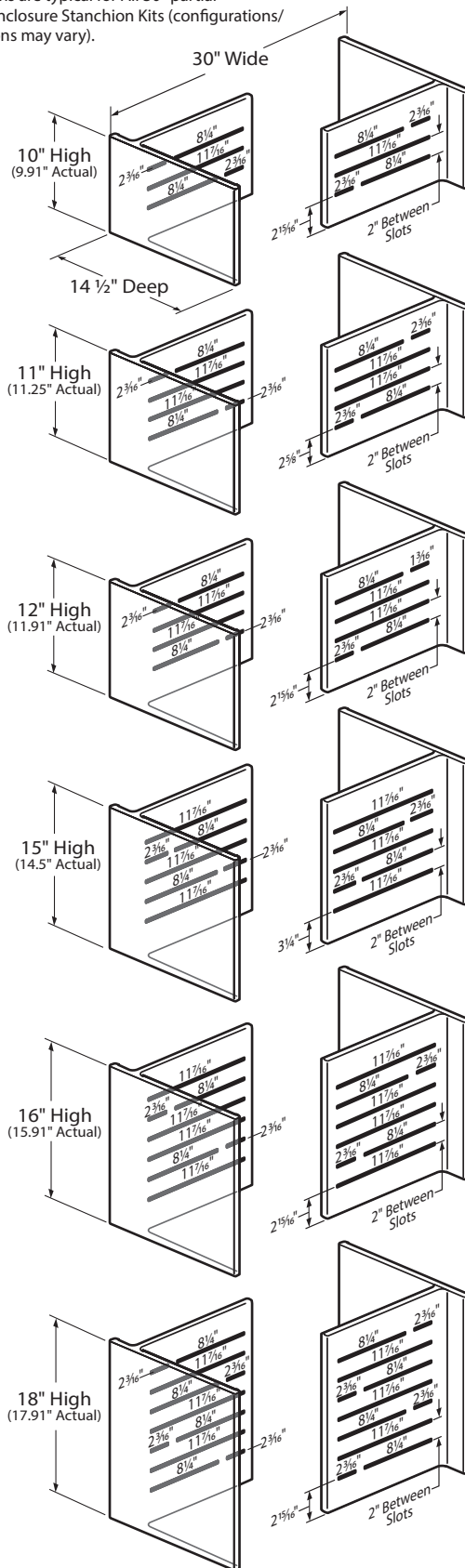

36" Wide Stanchions –

- Stanchion Kit-P shown with Mirror Image Configuration.
- Dimensions are typical for All 36" partial and full enclosure Stanchion Kits (configurations/orientations may vary).

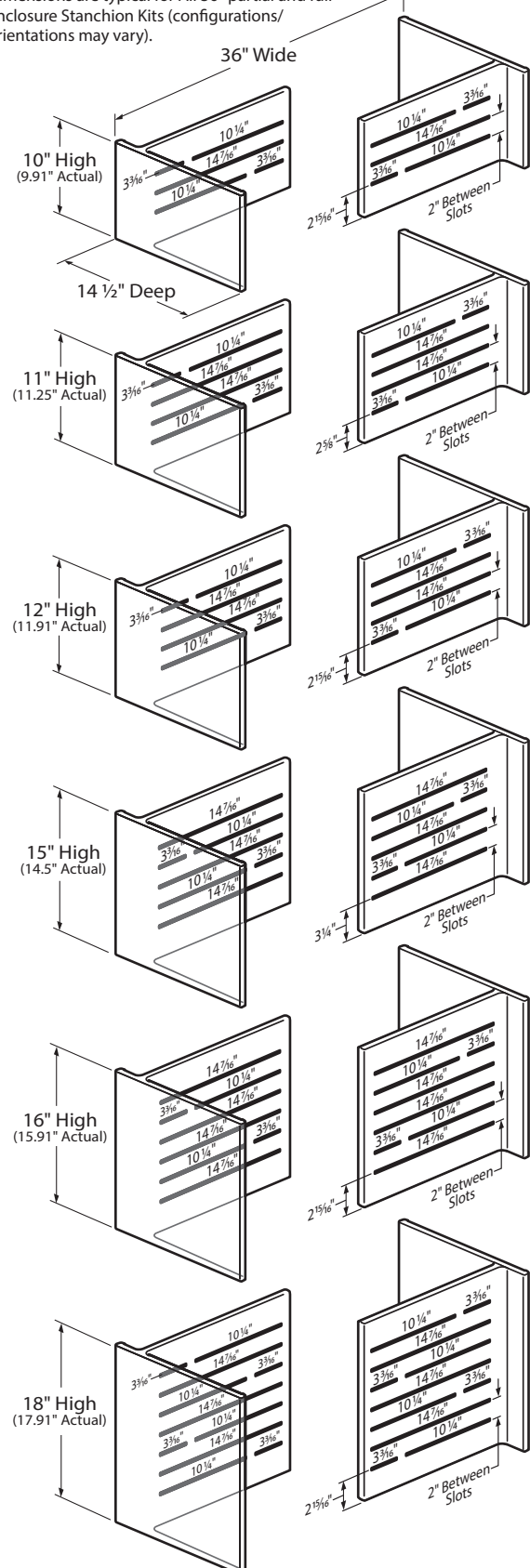

Product Details – Beside Storage

Stanchion Kits – Accessory Slot Dimensions – 42" Wide Stanchions

• Stanchion Accessory Slots may be used to accommodate separately specified Belong hanging accessories.

42" Wide Stanchions –

- Stanchion Kit-P shown with Mirror Image Configuration.
- Dimensions are typical for All 42" partial and full enclosure Stanchion Kits (configurations/orientations may vary).

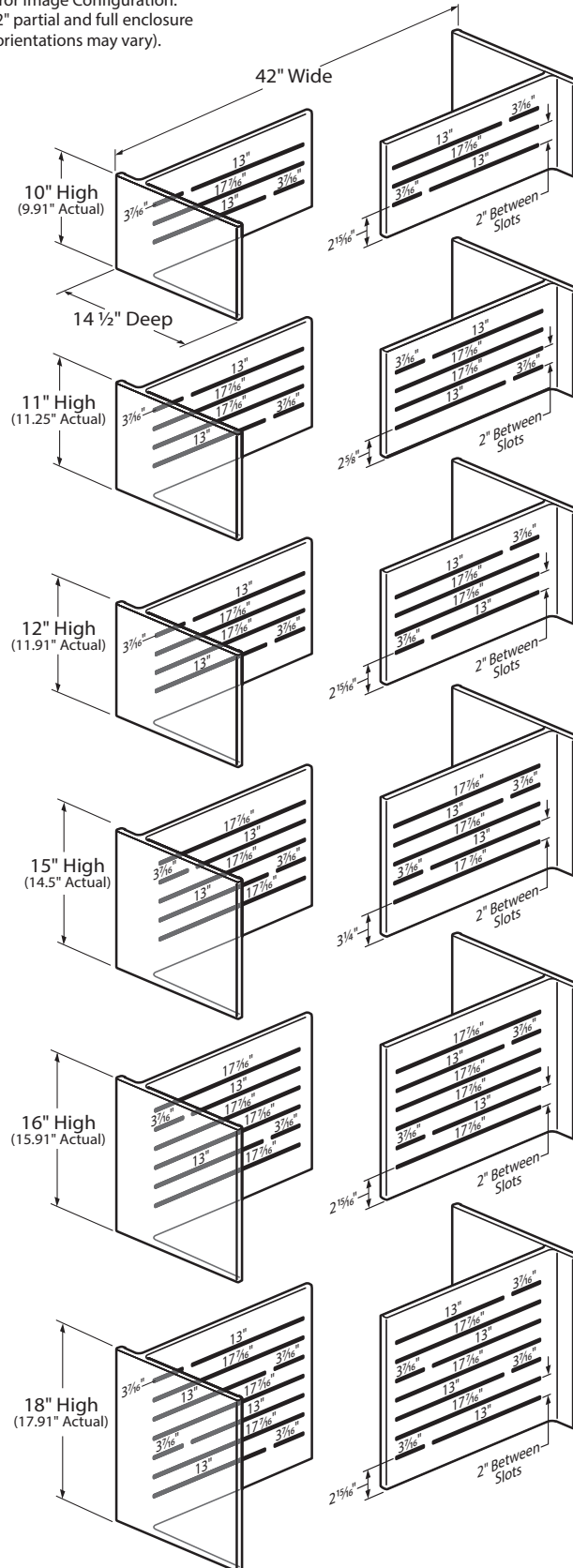

Product Details – Beside Storage

Stanchion Kits – Accessory Slot Dimensions – 48" Wide Stanchions

• Stanchion Accessory Slots may be used to accommodate separately specified Belong hanging accessories.

48" Wide Stanchions –

- Stanchion Kit-P shown with Mirror Image Configuration.
- Dimensions are typical for All 48" partial and full enclosure Stanchion Kits (configurations/orientations may vary).

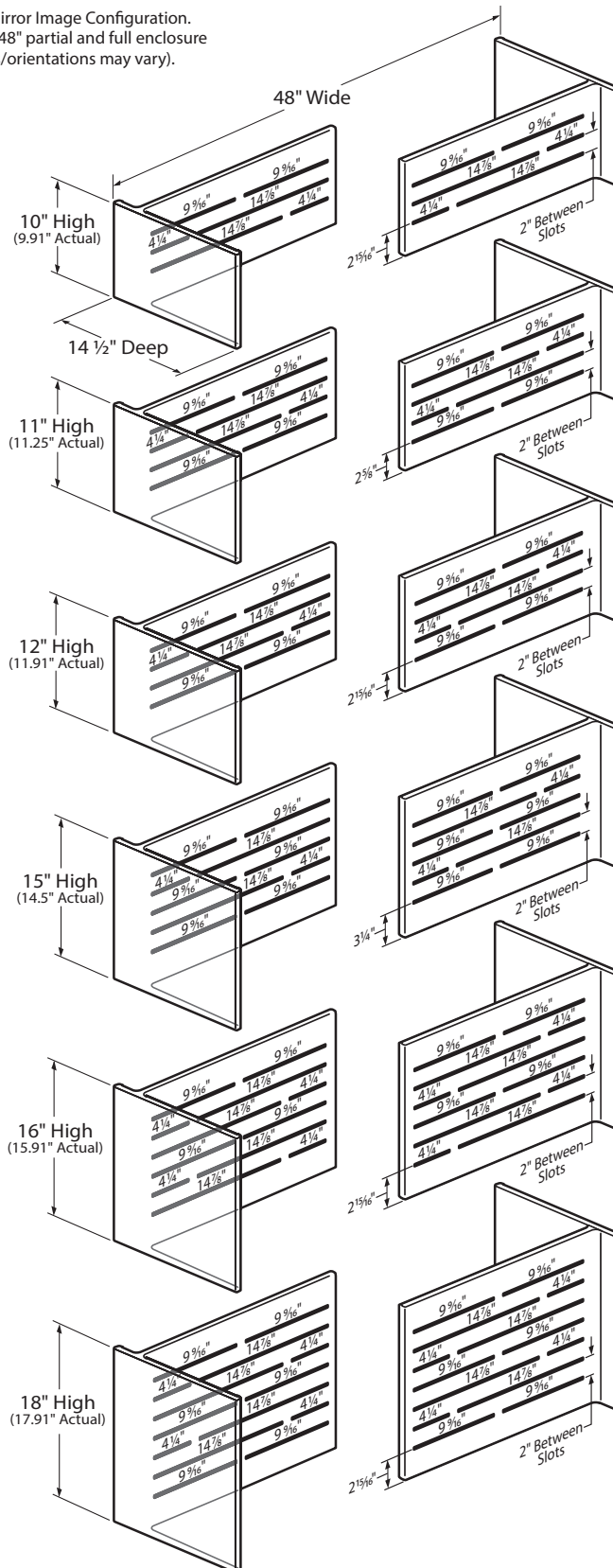

Product Details – Beside Storage

Stanchion Kits – Accessory Slot Dimensions – 54" Wide Stanchions

• Stanchion Accessory Slots may be used to accommodate separately specified Belong hanging accessories.

54" Wide Stanchions –

- Stanchion Kit-P shown with Mirror Image Configuration.
- Dimensions are typical for All 54" partial and full enclosure Stanchion Kits (configurations/orientations may vary).

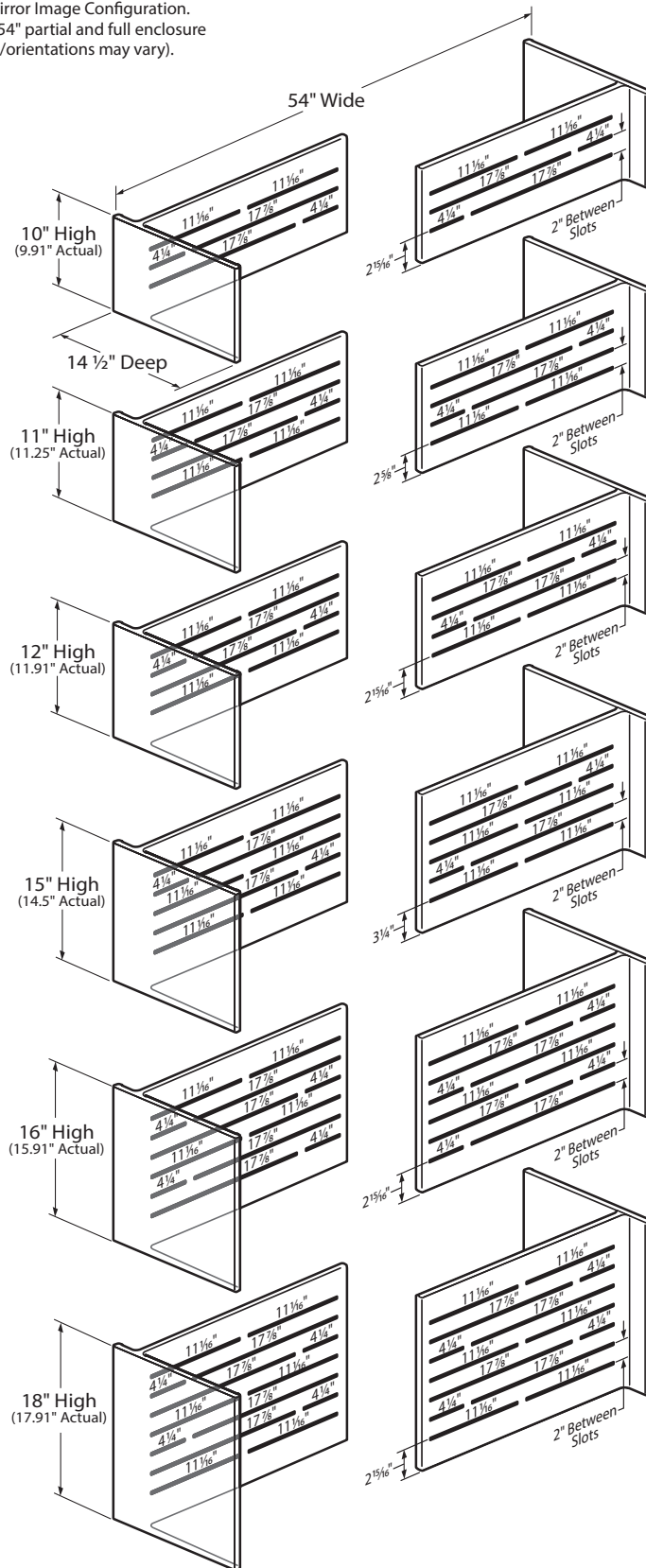

Product Details – Beside Storage

Stanchion Kits – Accessory Slot Dimensions – 60" Wide Stanchions

• Stanchion Accessory Slots may be used to accommodate separately specified Belong hanging accessories.

60" Wide Stanchions –

- Stanchion Kit-P shown with Mirror Image Configuration.
- Dimensions are typical for All 60" partial and full enclosure Stanchion Kits (configurations/orientations may vary).

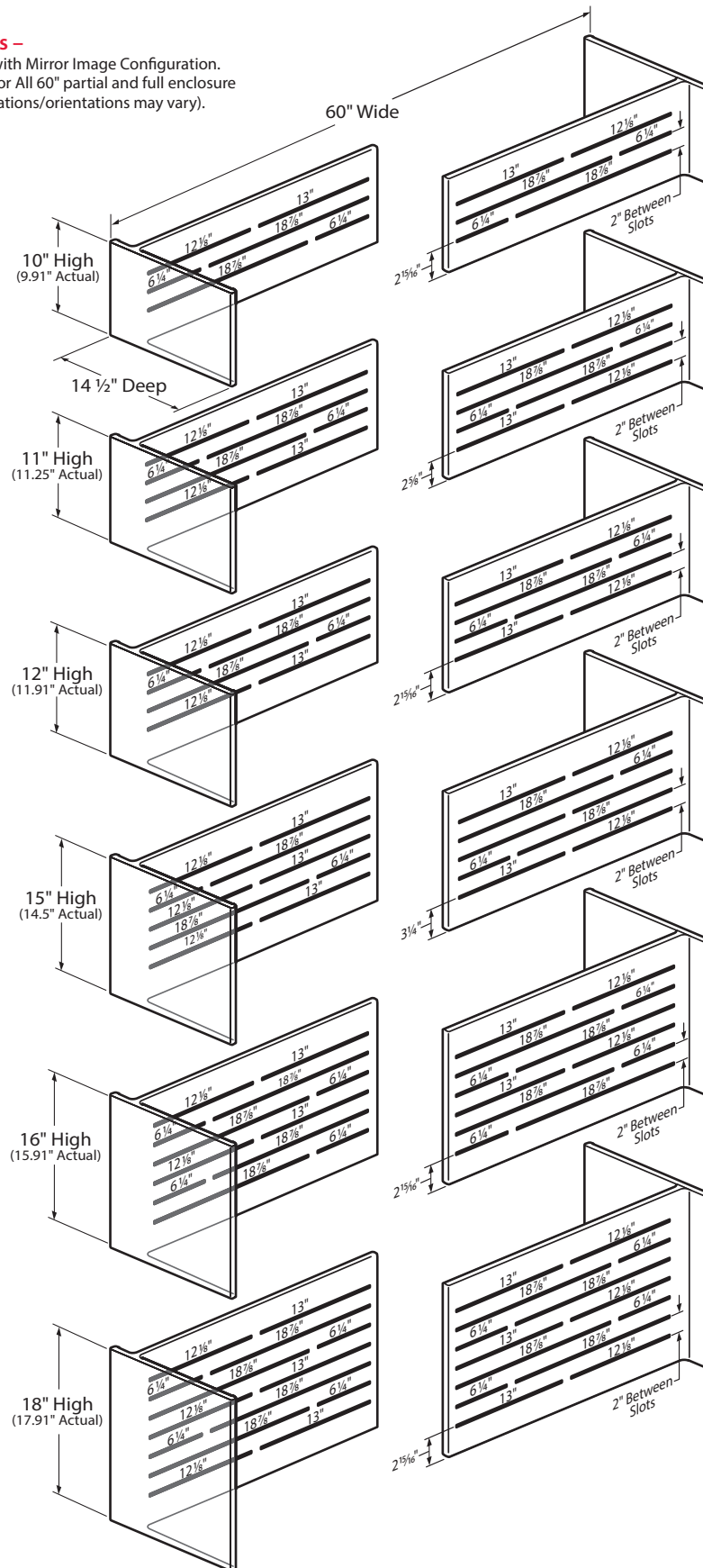

Product Details – Beside Storage

Stanchion Kits – Accessory Slot Dimensions – 66" Wide Stanchions

- Stanchion Accessory Slots may be used to accommodate separately specified Belong hanging accessories.

66" Wide Stanchions –

- Stanchion Kit-P shown with Mirror Image Configuration.
- Dimensions are typical for All 66" partial and full enclosure Stanchion Kits (configurations/orientations may vary).

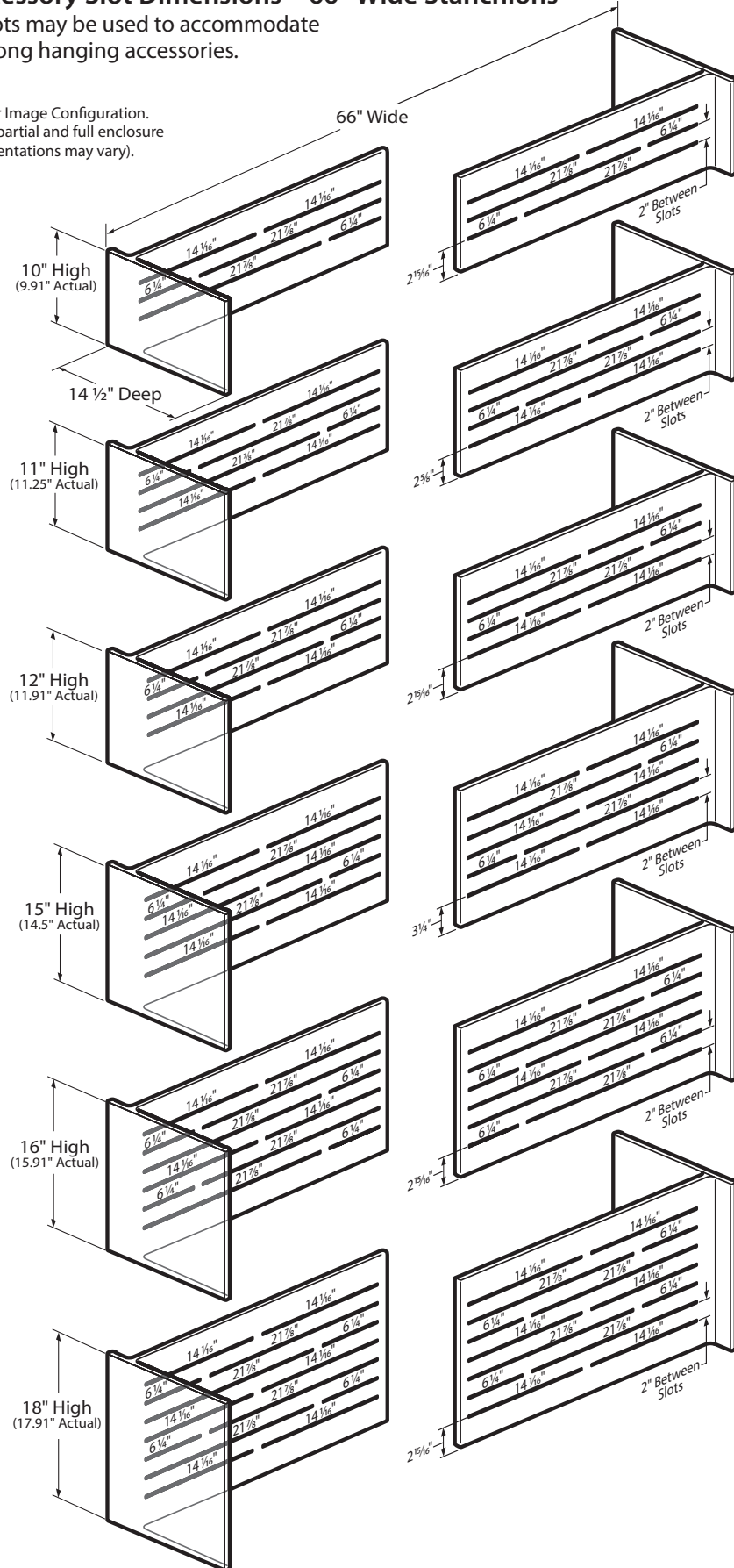

Product Details – Beside Storage

Stanchion Kits – Accessory Slot Dimensions – 72" Wide Stanchions

- Stanchion Accessory Slots may be used to accommodate separately specified Belong hanging accessories.

72" Wide Stanchions –

- Stanchion Kit-P shown with Mirror Image Configuration.
- Dimensions are typical for All 72" partial and full enclosure Stanchion Kits (configurations/orientations may vary).

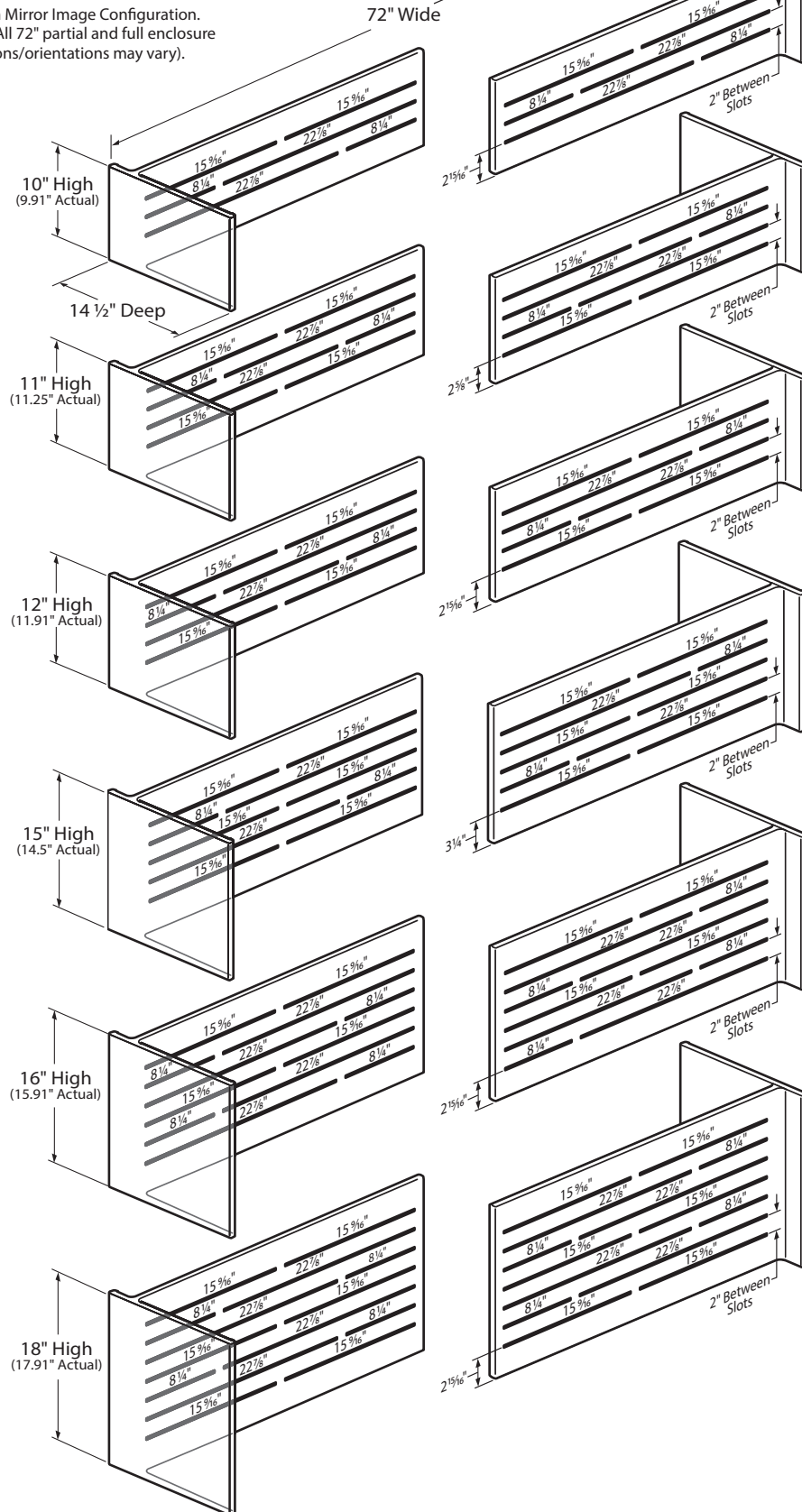

Product Details – Beside Storage

Stanchion Kits – Designing with Stanchion Kits – Orientation Options

- Stanchion Kits may be field orientated as needed for single or dual users.
- Orientation of the Stanchion Kit is installation dependent; no additional hardware is required.
- In the illustration below Stanchion Kit P is shown less than 48" wide in three possible user orientations.

Stanchion Kit Orientation Options (Installation dependent)

Single User Access

Both back panels of Left and Right Stanchions are adjacent or in-line to each other for single user access.

- Left hand Stanchion. Shown with both sided accessory slot specification option.
- Back panel of left Stanchion installed in back position for single user access.

Stanchion Kit-P Widths:
• 24"-42" accommodate a single sided application.

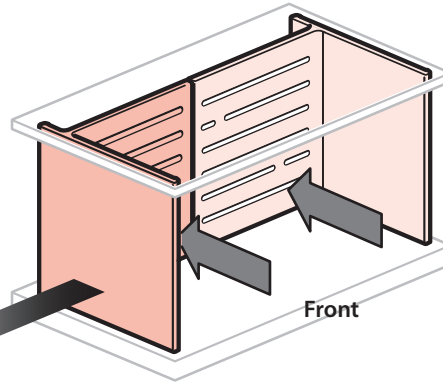

- Right hand Stanchion. Shown with both sided accessory slot specification option.
- Back panel of right Stanchion Installed in back position for single user access.



Left hand Stanchion is flip-flopped 180° to switch user orientation.

Dual User Access

- Back panel of left Stanchion installed in opposite position as right hand Stanchion for dual user access.

Stanchion Kit-P Widths:
• 24"-72" accommodate a dual sided application.

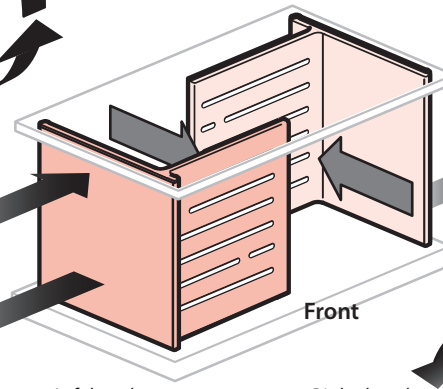

- Back panel of right Stanchion installed in opposite position as left Stanchion for dual user access.

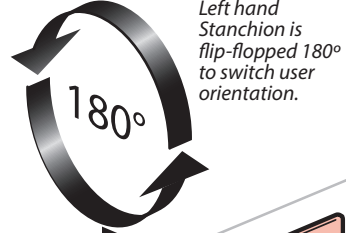

Left hand Stanchion is flip-flopped 180° to switch user orientation.

Right hand Stanchion is flip-flopped 180° to switch user orientation.

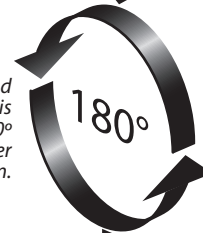

Dual User Access

- Back panel of left Stanchion installed in opposite position as right hand Stanchion for dual user access.

Stanchion Kit-P Widths:
• 24"-72" accommodate a dual sided application.

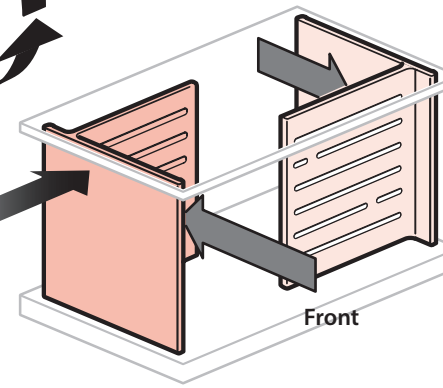

- Back panel of right Stanchion installed in opposite position as left Stanchion for dual user access.

Tip Installation drawings must depict Stanchion Kit orientation and color selection to ensure design intent.

Product Details – Beside Storage

Stanchion Kits – Specification Sequence For Stanchion Kit Paint Color

- Stanchion Kits are painted metal.
- Paint color specification sequence is shown below.

To Order, Specify:
 Product Number
1 Painted Color **Stanchion Left**
2 Painted Color **Stanchion Right**
3 Painted Color **Center Divider**

Single User Access

Both back panels of Left and Right Stanchions are adjacent or in-line to each other for single user access.

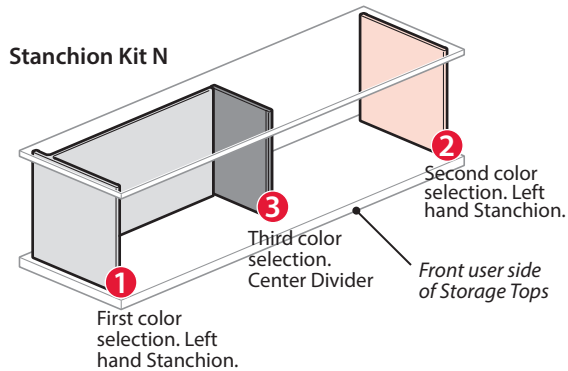
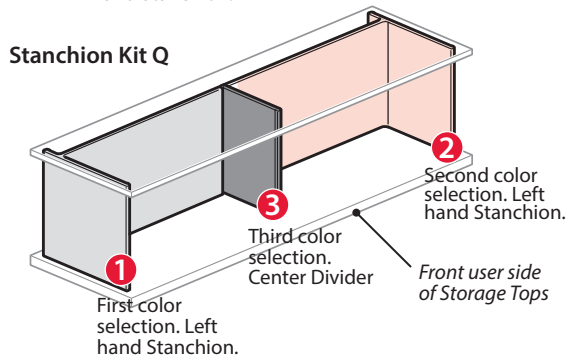
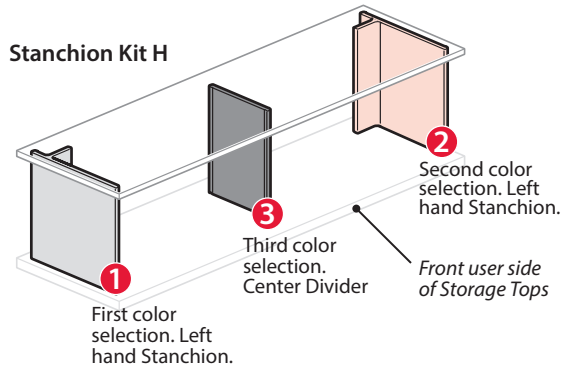

Dual User Access

Back panel of left Stanchion installed in opposite position as right hand Stanchion for dual user access.

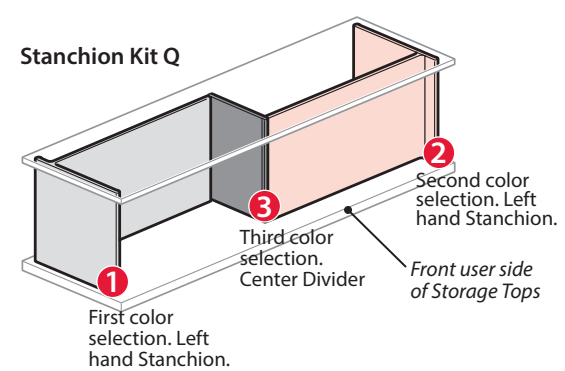
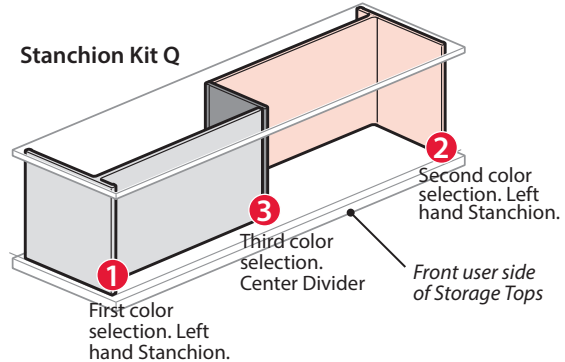
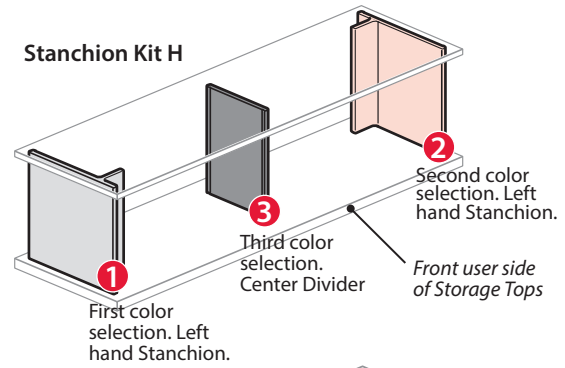

Tip Installation drawings must depict Stanchion Kit orientation and color selection to ensure design intent.

Note Paint color selections 1, 2 and 3 may be the same color or each one may be different color.

Product Details – Beside Storage

Hutch Shelf

- Hutch Shelf is available in laminate or wood.
- Laminate Hutch Shelf includes a 1mm edgeband on all sides.
- Wood Hutch Shelf includes a 0.6mm edgeband on all sides.
- The Hutch Shelf is installed on top of a separately specified Stanchion Kit to create a Hutch application.
- Hutch Shelf widths correspond with the Stanchion Kit widths.
- Hutch Shelf width must match the Stanchion Kit width; **may not span side-by-side Stanchion Kits.**
- Hutch Shelf adds 3/4" to the Stanchion Kit height.
- Hutch Shelf is not required when using Overhead Storage Unit.
- Shelves 48" or wider can only be used with Stanchion Kits H, N, P and Q.
- The overall height of a Hutch application must not exceed 58".
- Separately specified Adaptable LED light may be attached to underside of Hutch Shelf.

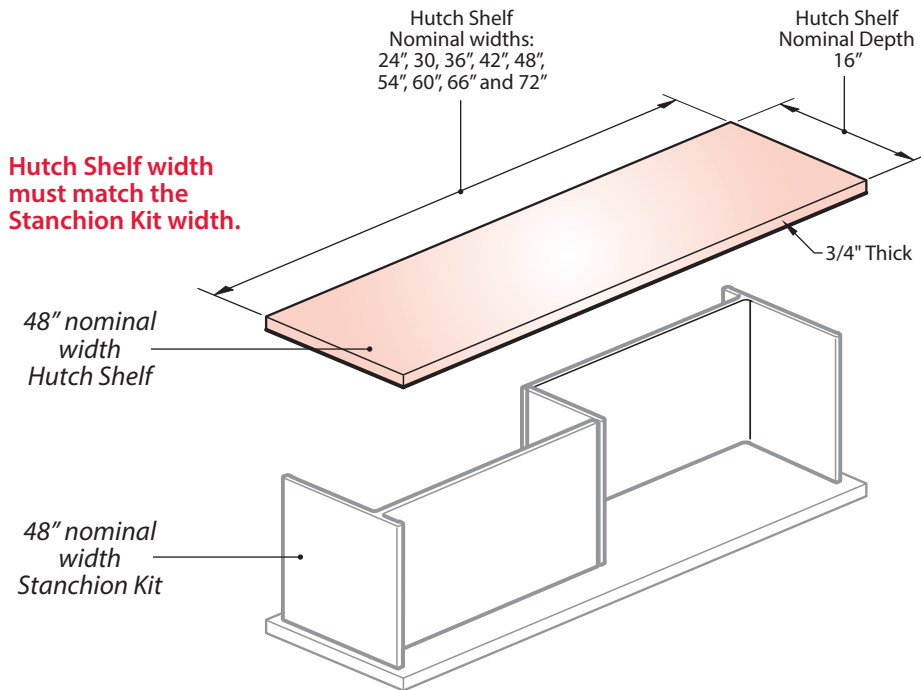

Laminate Edgeband Detail

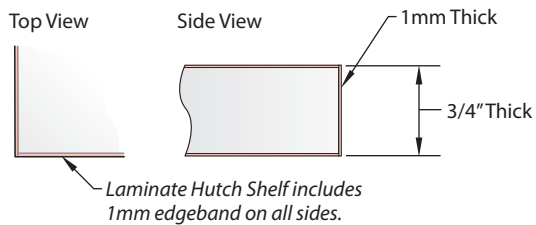

Wood Edgeband Detail

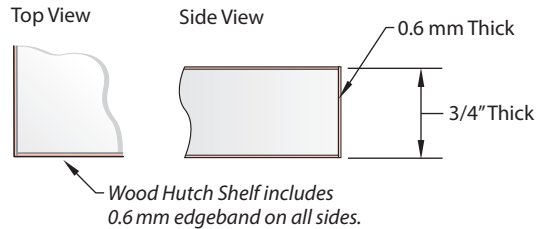

Product Details – Beside Storage

Overhead Storage Units – Single Sided / Open – Dimensions

This non-handed OSU is available in 24”–72” (610mm–1829mm) wide and provides single sided user access. Includes one or two functional sections depending on the width of the OSU. A full width back panel encloses the back of the unit.

Single Sided Access – Open
QUS1-16__-H_NNN
24”-72” Wide

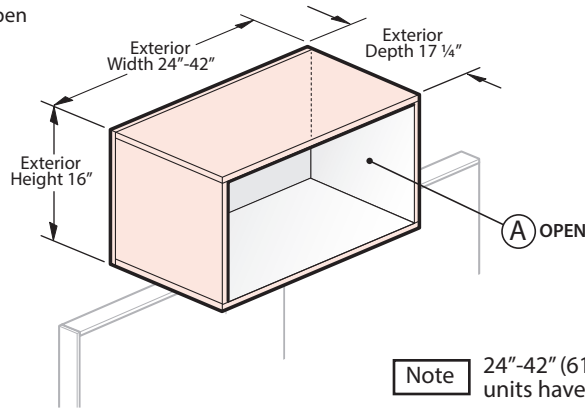

Note 24”-42” (610mm-1067mm) wide units have one open section.

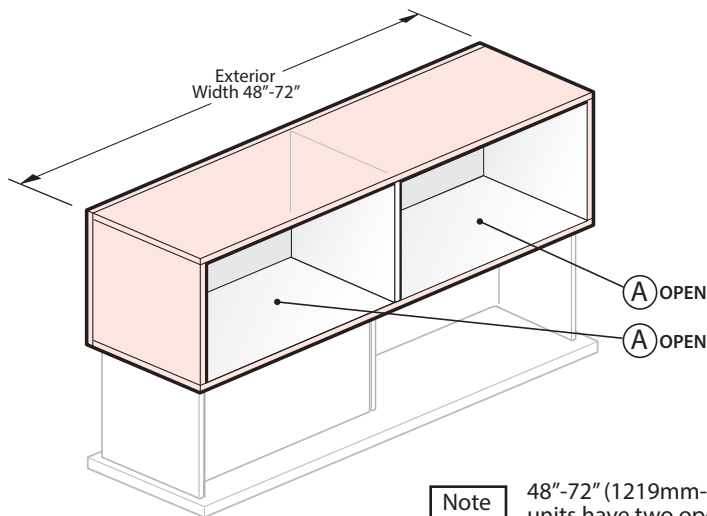

Note 48”-72” (1219mm-1829mm) wide units have two open sections.

HEIGHT	Interior Height (Actual Dimension)	(A) (14 1/2”) High								
	Exterior Width Nominal	24” Wide	30” Wide	36” Wide	42” Wide	48” Wide	54” Wide	60” Wide	66” Wide	72” Wide
WIDTH	Interior Width Functional Sections (Actual Dimension)	(A) (22 7/16” W)	(A) (28 7/16” W)	(A) (34 7/16” W)	(A) (40 7/16” W)	(A) (22.85” W)	(A) (25 7/8” W)	(A) (28 7/8” W)	(A) (31 7/8” W)	(A) (34 7/8” W)
	Interior Depth Functional Sections (Actual Dimension)	(A) (16 1/2”) Deep								

Note • Interior dimensions vary per OSU functionality; dimensions are specific to the OSU unit shown.

- Tip**
- For use above a Beside Stanchion Kit or a Compose, UniGroup Too or PREMISE systems panel; top of OSU not to exceed 66” high.
 - Beside OSU may not be stacked above each other or directly located on a Beside or Adaptable Worksurface.

Product Details – Beside Storage

Overhead Storage Units – Single Sided / Hinged Door – Dimensions

This handed OSU is available in 24" – 72" (610mm–1829mm) wide and provides single sided user access. Includes two functional sections with a single or a pair of hinged doors depending on the width of the OSU. A full width back panel encloses the back of the unit.

Single Sided Access –
Hinged Door (Left) /
Open (Right)
QUS1-16__-A__N__
24" – 72" Wide

Alternative Configuration:
Single Sided – Open (Left) /
Hinged Door (Right)
QUS1-16__-B__N__

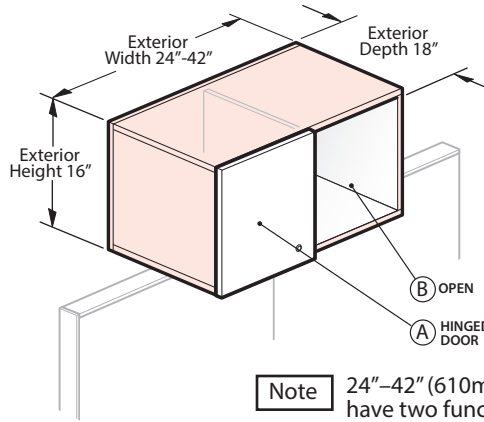

Note 24"–42" (610mm–1067mm) wide units have two functional sections; a single hinged door section and an open section.

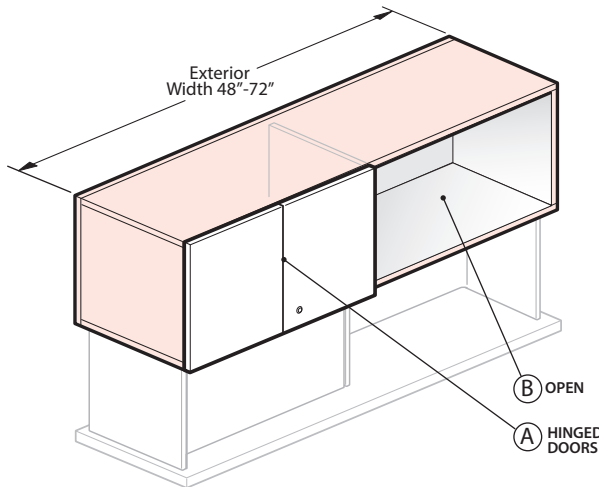

Note 48"–72" (1219mm–1829mm) wide units have two functional sections; a section with a pair of hinged doors and an open section.

HEIGHT	Interior Height Nominal (Actual)	(A) (B) (14 1/2") High								
	Exterior Width Nominal (Actual)	24" Wide	30" Wide	36" Wide	42" Wide	48" Wide	54" Wide	60" Wide	66" Wide	72" Wide
WIDTH	Interior Width Functional Sections (Actual Dimension)	(A) (10 1/2"W)	(A) (13 1/2"W)	(A) (16 1/2"W)	(A) (19 1/2"W)	(A) (22 1/2"W)	(A) (25 1/2"W)	(A) (28 1/2"W)	(A) (31 1/2"W)	(A) (34 1/2"W)
		(B) (11 1/4"W)	(B) (14 1/4"W)	(B) (17 1/4"W)	(B) (20 1/4"W)	(B) (23 1/4"W)	(B) (26 1/4"W)	(B) (29 1/4"W)	(B) (32 1/4"W)	(B) (35 1/4"W)
DEPTH	Interior Depth (Functional Sections) Nominal (Actual)	(A) (B) (16 1/2") Deep								

Note • Interior dimensions vary per OSU functionality; dimensions are specific to the OSU unit shown.

- Tip**
- For use above a Beside Stanchion Kit or a Compose, UniGroup Too or PREMISE systems panel; top of OSU not to exceed 66" high.
 - Beside OSU may not be stacked above each other or directly located on a Reside or Adaptable Worksurface.

Product Details – Beside Storage

Overhead Storage Units – Single Sided / Full Hinged Doors – Dimensions

This non-handed OSU is available in 24"–72" (610mm–1829mm) wide and provides single sided user access. Includes one or two functional sections depending on the width. A full width back panel encloses the back of the unit.

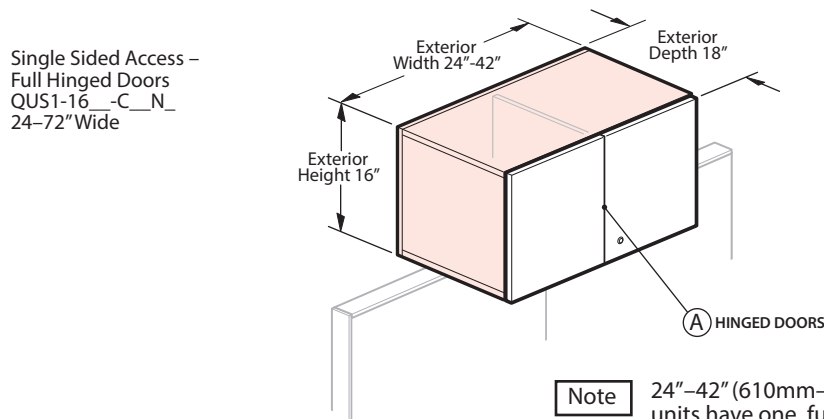

Note 24"–42" (610mm–1067mm) wide units have one functional section with a pair of hinged doors.

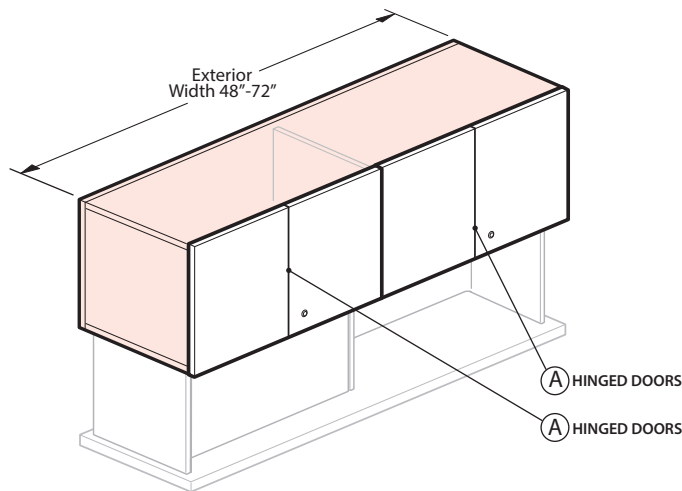

Note 48"–72" (1219mm–1829mm) wide units have two functional sections; each section has a pair of hinged doors.

HEIGHT	Interior Height (Actual Dimension)	(A) (14 1/2") High								
	Exterior Width Nominal (Actual)	24" Wide	30" Wide	36" Wide	42" Wide	48" Wide	54" Wide	60" Wide	66" Wide	72" Wide
WIDTH	Interior Width Functional Sections (Actual Dimension)	(A) (22 7/16" W)	(A) (28 7/16" W)	(A) (34 7/16" W)	(A) (40 7/16" W)	(A) (22 7/8" W)	(A) (25 7/8" W)	(A) (28 7/16" W)	(A) (31 7/16" W)	(A) (34 1/2" W)
	Interior Depth Functional Sections (Actual Dimension)	(A) (16 1/2") Deep								

Note • Interior dimensions vary per OSU functionality; dimensions are specific to the OSU unit shown.

- Tip**
- For use above a Beside Stanchion Kit or a Compose, UniGroup Too or PREMISE systems panel; top of OSU not to exceed 66" high.
 - Beside OSU may not be stacked above each other or directly located on a Reside or Adaptable Worksurface.

Product Details – Beside Storage

Overhead Storage Units – Single Sided / Single Sliding Door – Right or Left – Dimensions

This handed OSU is available in 30"–72" (762mm–1829mm) wide and provides single sided user access. Includes two functional sections. Both functional sections are accessible from the same side of the case. A single sliding door is proud of the case and designates the handedness. The sliding door may be positioned to enclose the right or left-hand section leaving the adjacent section open. A full width back panel encloses the back of the unit.

Single Sided Access –
Proud Sliding Door (Left) / Open (Right)
QUS1-16__-E__V__
30"–72" Wide

Alternative Configuration:
Open (Left) / Proud Sliding Door (Right)
QUS1-16__-D__V__
30"–72" Wide

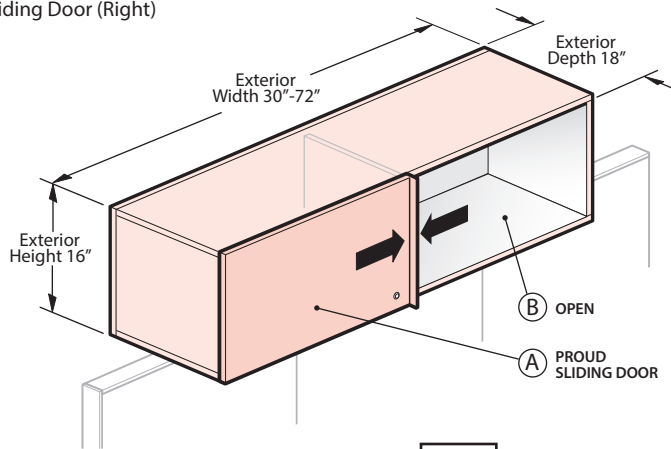

Note

- Left Hand Unit (shown)– pull is located on the right side of the proud door.
- Right Hand Unit - pull is located on the left side of the proud door.
- Proud sliding door specified as locking, will include a lock.
- Right or left sliding door configurations determine lock location.
- Door shown in locked position.
- Door pull is adjacent to lock location.

HEIGHT	Interior Height Nominal (Actual)	(A) (B) (14 1/2") High							
	Exterior Width Nominal (Actual)	30" Wide	36" Wide	42" Wide	48" Wide	54" Wide	60" Wide	66" Wide	72" Wide
WIDTH	Interior Width Functional Sections (Actual Dimension)	(A) (13 1/2" W)	(A) (16 1/2" W)	(A) (19 1/2" W)	(A) (22 1/2" W)	(A) (25 1/2" W)	(A) (28 1/2" W)	(A) (31 1/2" W)	(A) (34 1/2" W)
		(B) (14 1/4" W)	(B) (17 1/4" W)	(B) (20 1/4" W)	(B) (23 1/4" W)	(B) (26 1/4" W)	(B) (29 1/4" W)	(B) (32 1/4" W)	(B) (35 1/4" W)
DEPTH	Interior Depth (Functional Sections) Nominal (Actual)	(A) (B) (16 1/2") Deep							

Note • Interior dimensions vary per OSU functionality; dimensions are specific to the OSU unit shown.

- Tip**
- For use above a Beside Stanchion Kit or a Compose, UniGroup Too or PREMISE systems panel; top of OSU not to exceed 66" high.
 - Beside OSU may not be stacked above each other or directly located on a Reside or Adaptable worksurface.

Product Details – Beside Storage

Overhead Storage Units – Single Sided / Double Sliding Doors – Right or Left – Dimensions

This handed OSU is available in 30"–72" (762mm–1829mm) wide and provides single sided user access. Includes two functional sections. Both functional sections are accessible from the same side of the case. A single sliding door is proud of the case and designates the handedness. A full width back panel encloses the back of the unit.

Single Sided Access –
Proud Sliding Door (Left) /
Recessed Sliding Door (Right)
QUS1-16___G___V___
30"–72" Wide

Alternative Configuration:
Recessed Sliding Door (Left) /
Proud Sliding Door (Right)
QUS1-16___F___V___
30"–72" Wide

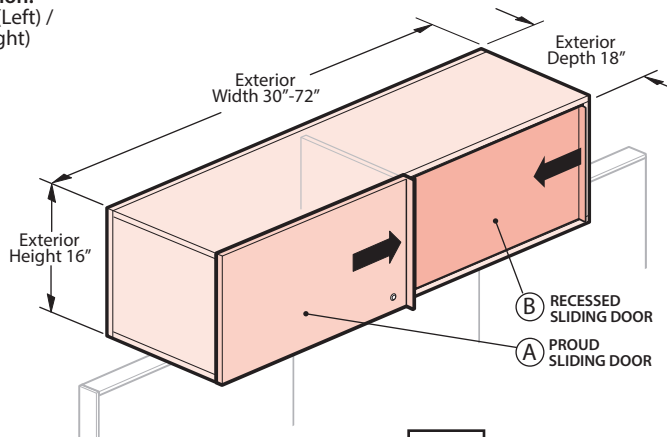

Note

- Left Hand Unit (shown) – pull is located on the right side of the proud door.
- Right Hand Unit - pull is located on the left side of the proud door.
- Double sliding door units 30"- 42" wide don't get a divider on non-locking units.
- Proud sliding door specified as locking, will include a lock.
- Right or left double sliding door configurations determine lock location.
- Door shown in locked position.
- Door pull is adjacent to lock location.

HEIGHT	Interior Height Nominal (Actual)	(A) (B) (14 1/2") High							
	Exterior Width Nominal (Actual)	30" Wide	36" Wide	42" Wide	48" Wide	54" Wide	60" Wide	66" Wide	72" Wide
WIDTH	Interior Width Functional Sections (Actual Dimension)	(A) (13 1/2" W)	(A) (16 1/2" W)	(A) (19 1/2" W)	(A) (22 1/2" W)	(A) (25 1/2" W)	(A) (28 1/2" W)	(A) (31 1/2" W)	(A) (34 1/2" W)
		(B) (14 1/4" W)	(B) (17 1/4" W)	(B) (20 1/4" W)	(B) (23 1/4" W)	(B) (26 1/4" W)	(B) (29 1/4" W)	(B) (32 1/4" W)	(B) (35 1/4" W)
DEPTH	Interior Depth (Functional Sections) Nominal (Actual)	(A) (B) (16 1/2") Deep							

Note

- Interior dimensions vary per OSU functionality; dimensions are specific to the OSU unit shown.

Tip

- For use above a Beside Stanchion Kit or a Compose, UniGroup Too or PREMISE systems panel; top of OSU not to exceed 66" high.
- Beside OSU may not be stacked above each other or directly located on a Reside or Adaptable Worksurface.

Product Details – Beside Storage

Overhead Storage Units – Dual Sided / Open – Dimensions

This handed OSU is available in 48"–72" (1219mm–1829mm) wide and provides dual user access. Includes two open functional sections. One functional section is accessible per each side of the OSU. The open front designates the user access side and handedness. A closed back panel is located adjacent to each open front.

Dual Sided Access –
Open (Left/Back) /
Open (Right/Front)
QUS2-16___-J_NNN
48"–72" Wide

Alternative Configuration:
Dual Sided – Open (Left/Front) /
Open (Right/Back)
QUS2-16___-K_NNN
48"–72" Wide

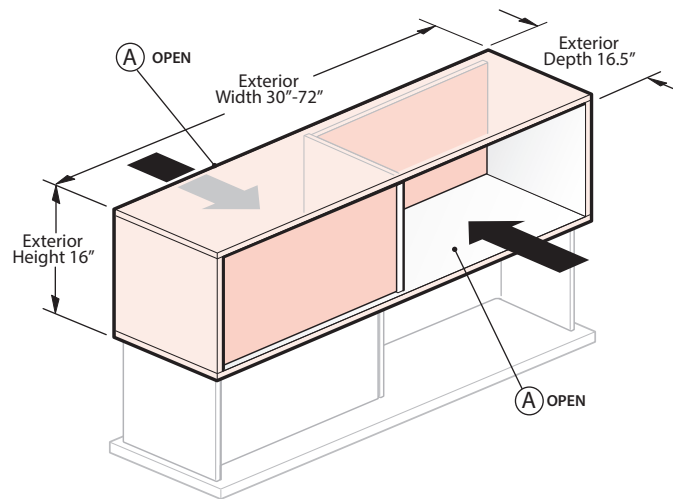

HEIGHT	Interior Height Nominal (Actual)	Ⓐ (14 ½") High				
	Exterior Width Nominal (Actual)	48" Wide	54" Wide	60" Wide	66" Wide	72" Wide
WIDTH	Interior Width Functional Sections (Actual Dimension)	Ⓐ (22 ⅞" W)	Ⓐ (25 ⅞" W)	Ⓐ (28 ⅞" W)	Ⓐ (31 ⅞" W)	Ⓐ (34 ⅞" W)
	Interior Depth (Functional Sections) Nominal (Actual)	Ⓐ (14 ⅝") Deep				

Note • Interior dimensions vary per OSU functionality; dimensions are specific to the OSU unit shown.

Tip • For use above a Beside Stanchion Kit or a Compose, UniGroup Too or PREMISE systems panel; top of OSU not to exceed 66" high.
• Beside OSU may not be stacked above each other or directly located on a Reside or Adaptable Worksurface.

Product Details – Beside Storage

Overhead Storage Units – Dual Sided / Sliding Door – Dimensions

This handed OSU is available in 48"–72" (1219mm–1829mm) wide and provides dual sided user access. Includes two functional sections. One functional section is accessible per each side of the OSU. The single sliding door is proud of the case and designates the user access side and handedness. A closed back panel is located adjacent to each sliding door.

Dual Sided Access –
Sliding Door (Left/Back) /
Sliding Door (Right/Front)
QUS2-16__-D__V__
48"–72" Wide

Alternative Configuration:
Dual Sided –
Sliding Door (Left/Front) /
Sliding Door (Right/Back)
QUS2-16__-E__V__
48"–72" Wide

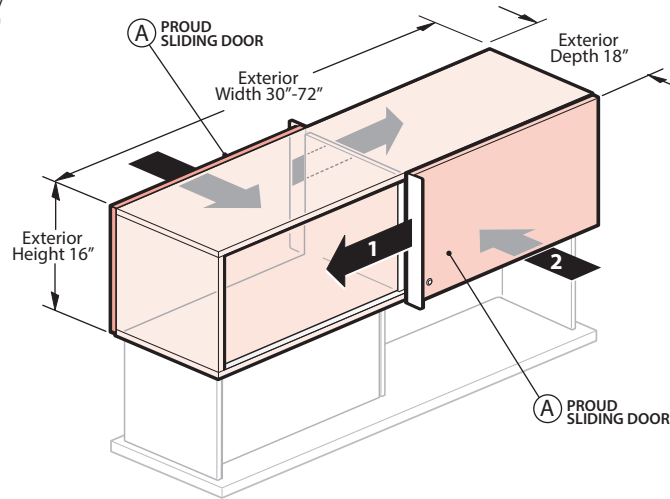

HEIGHT	Interior Height Nominal (Actual)	Ⓐ (14 ½") High				
	Exterior Width Nominal (Actual)	48" Wide	54" Wide	60" Wide	66" Wide	72" Wide
WIDTH	Interior Width Functional Sections (Actual Dimension)	Ⓐ (22 ⅞" W)	Ⓐ (25 ⅞" W)	Ⓐ (28 ⅞" W)	Ⓐ (31 ⅞" W)	Ⓐ (34 ⅞" W)
	Interior Depth (Functional Sections) Nominal (Actual)	Ⓐ (13 ½") Deep				

Note • Interior dimensions vary per OSU functionality; dimensions are specific to the OSU unit shown.

- Tip**
- For use above a Beside Stanchion Kit or a Compose, UniGroup Too or PREMISE systems panel; top of OSU not to exceed 66" high.
 - Beside OSU may not be stacked above each other or directly located on a Beside or Adaptable Worksurface.

Product Details – Beside Storage

Storage Pantry – 28" High

24" Deep (Closed Position)

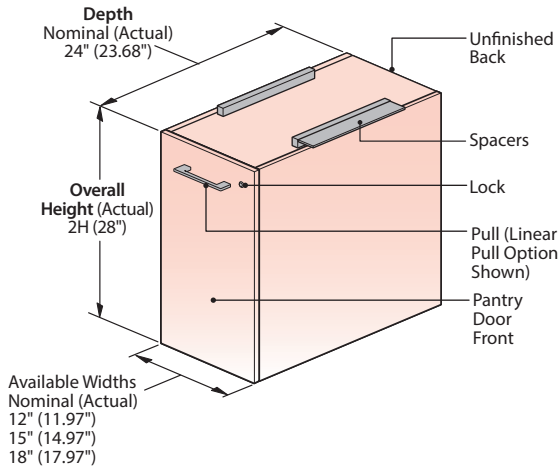

24" Deep (Open Position)

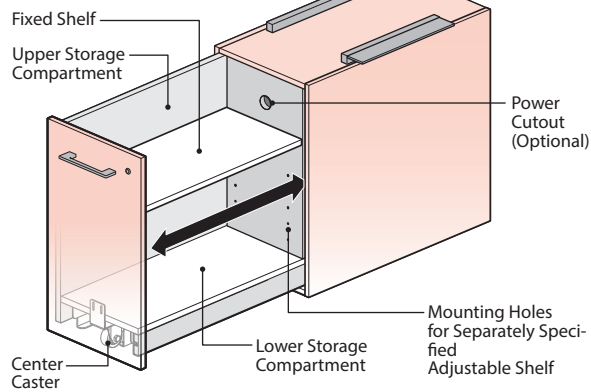

Component Materials/Finishes

COMPONENT NAME	MATERIALS/ FINISHES
Case and Pantry	Laminate Case with unfinished back and matching Laminate Pantry Interior and Laminate fixed shelf.
	Wood Case with unfinished back and specifiable Laminate Pantry Interior and laminate fixed shelf.
Pantry Door Front	Laminate
	Wood
Pulls	(Q) Blade Pull – Available in Trim Color
	(7) Crescent – Brushed Nickel Finish
	(8) Linear – Brushed Nickel Finish
	(9) Classic – Brushed Nickel Finish
Lock	Chrome
Spacer	Painted Metal – Trim Color

Orientation Options:

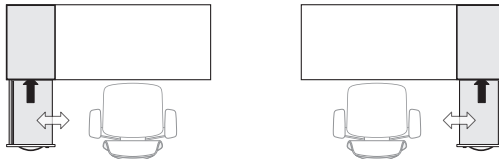

(L) Left Hand –
If pantry is located on left-hand side of the user it is left-handed.

(R) Right Hand –
If pantry is located on right-hand side of user it is right-handed.

Dimensions:

Case		Pantry Interior	
Depth Nominal (Actual)	Width Nominal (Actual)	(A)	(B)
24" (22.93")	12" (11.97")	9 1/4"	4 5/8"
	15" (14.97")	12 1/4"	6 1/8"
	18" (17.97")	15 1/4"	7 5/8"

Front View

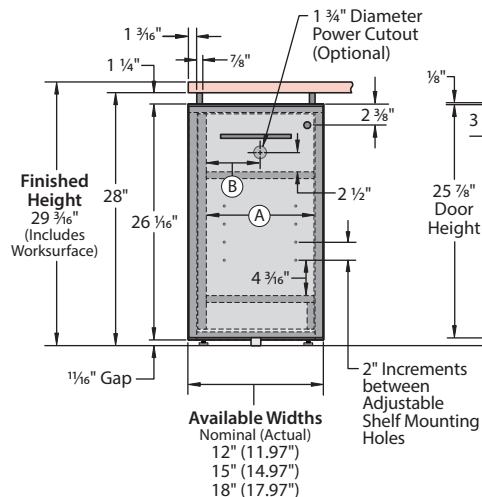

Side View (Closed Position)

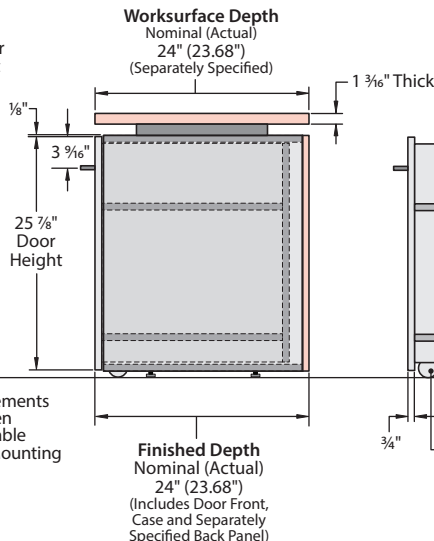

Side View (Open Position)

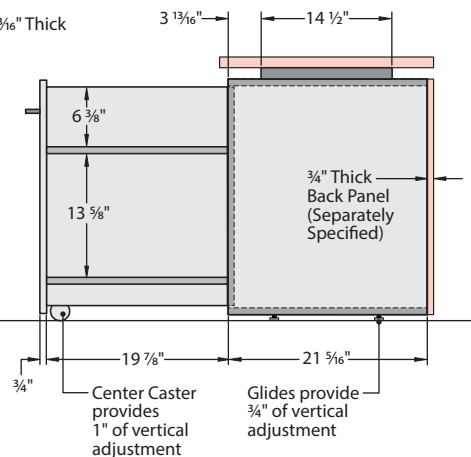

Product Details – Beside Storage

Storage Pantry – 28" High

30" Deep (Closed Position)

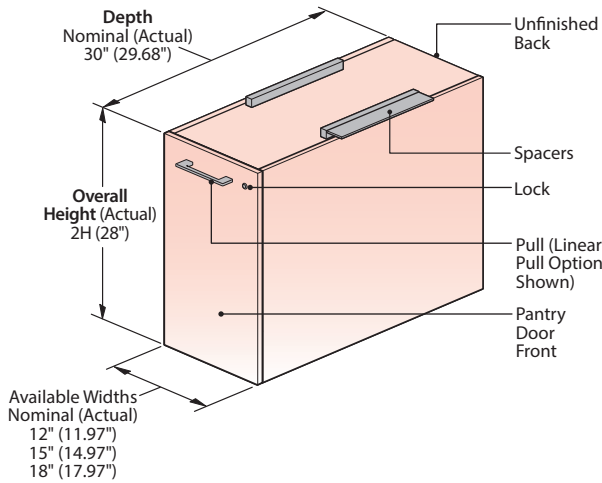

30" Deep (Open Position)

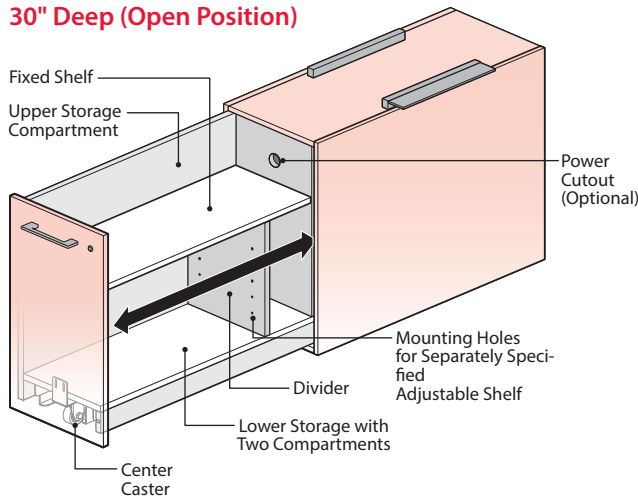

Component Materials/Finishes

COMPONENT NAME	MATERIALS/ FINISHES
Case and Pantry	Laminate Case with unfinished back and matching Laminate Pantry Interior and Laminate fixed shelf.
	Wood Case with unfinished back and specifiable Laminate Pantry Interior and laminate fixed shelf.
Pantry Door Front	Laminate
	Wood
Pulls	(Q) Blade Pull – Available in Trim Color
	(7) Crescent – Brushed Nickel Finish
	(8) Linear – Brushed Nickel Finish
	(9) Classic – Brushed Nickel Finish
Lock	Chrome
Spacer	Painted Metal – Trim Color

Orientation Options:

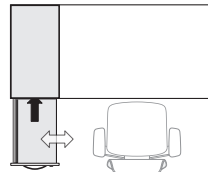

(L) Left Hand –
If pantry is located on left-hand side of the user it is left-handed.

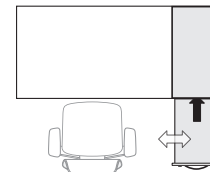

(R) Right Hand –
If pantry is located on right-hand side of the user it is right-handed.

Dimensions:

Case		Pantry Interior	
Depth Nominal (Actual)	Width Nominal (Actual)	(A)	(B)
30" (28.93")	12" (11.97")	9 1/4"	4 5/8"
	15" (14.97")	12 1/4"	6 1/8"
	18" (17.97")	15 1/4"	7 3/8"

Front View

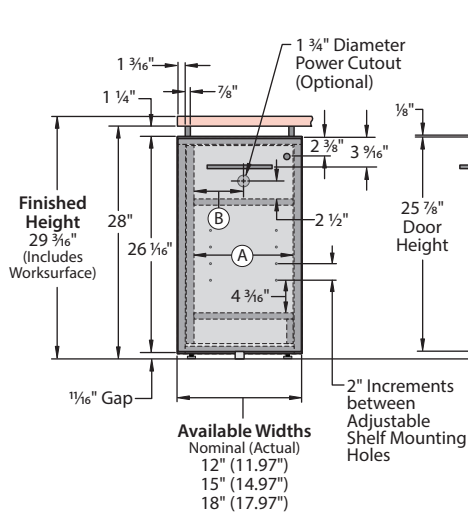

Side View (Closed Position)

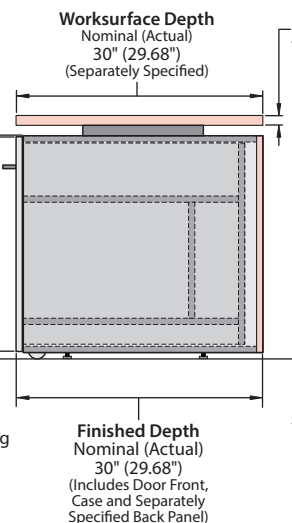

Side View (Open Position)

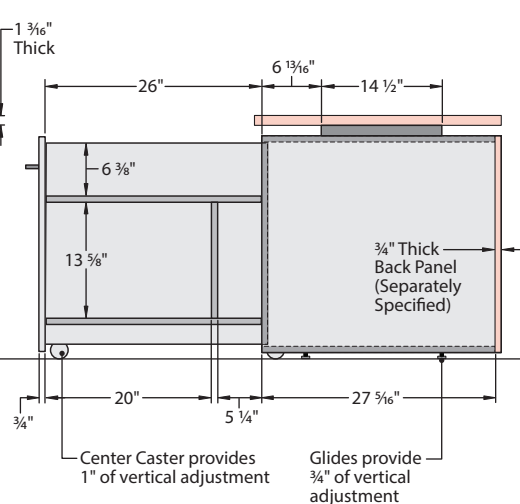

Product Details – Beside Storage

Beside Storage Pantry – 40" High

24" Deep (Closed Position)

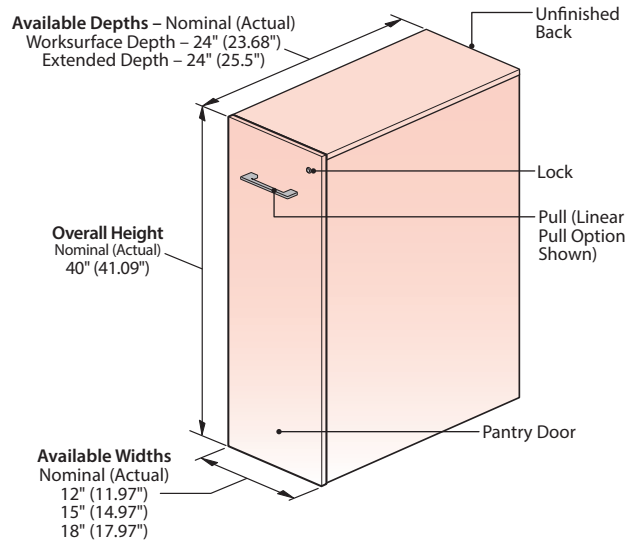

24" Deep (Open Position)

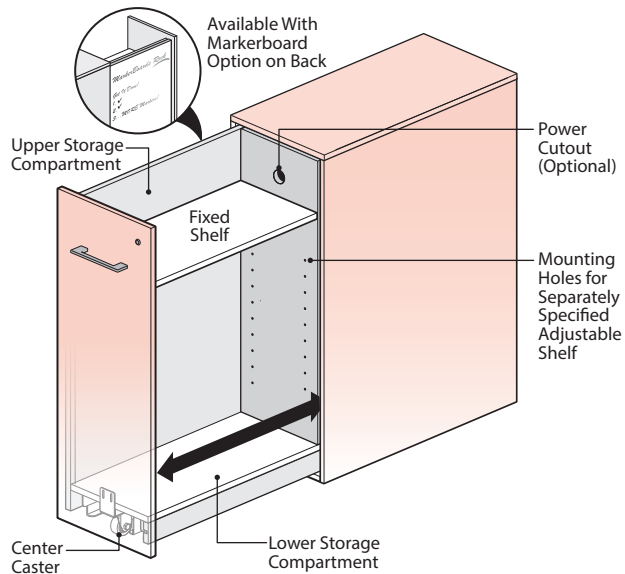

Component Materials/Finishes

COMPONENT NAME	MATERIALS/ FINISHES
Case and Pantry	Laminate Case with unfinished back and matching Laminate Pantry Interior and Laminate fixed shelf.
	Wood Case with unfinished back and specifiable Laminate Pantry Interior and laminate fixed shelf.
Pantry Door	Laminate
	Wood
Pulls	(Q) Blade Pull – Available in Trim Color
	(7) Crescent – Brushed Nickel Finish
	(8) Linear – Brushed Nickel Finish
	(9) Classic – Brushed Nickel Finish
Lock	Chrome

Orientation Options:

(L) Left Hand

If pantry is located on left-hand side of the user it is left-handed.

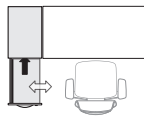

(R) Right Hand

If pantry is located on right-hand side of user it is right-handed.

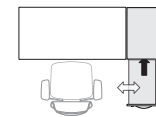

Depth Options:

Worksurface Depth
Matches Worksurface Depth.

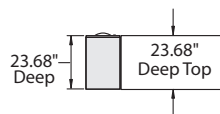

Extended Depth
Back-to-Back Pantry condition used with a double sided benching/panel applications.

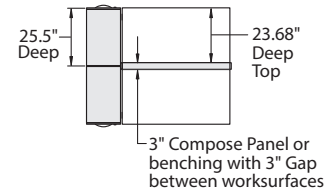

Dimensions

Overall Dimensions		Case	Pantry Interior	
Depth Nominal (Actual)	Width Nominal (Actual)	(A)	(B)	(C)
Worksurface Depth 24" (23.68")	12" (11.97")	22 13/16"	9 1/4"	4 5/8"
	15" (14.97")	22 13/16"	12 1/4"	6 1/8"
	18" (17.97")	22 13/16"	15 1/4"	7 5/8"
Extended Depth 24" (25.5")	12" (11.97")	24 11/16"	9 1/4"	4 5/8"
	15" (14.97")	24 11/16"	12 1/4"	6 1/8"
	18" (17.97")	24 11/16"	15 1/4"	7 5/8"

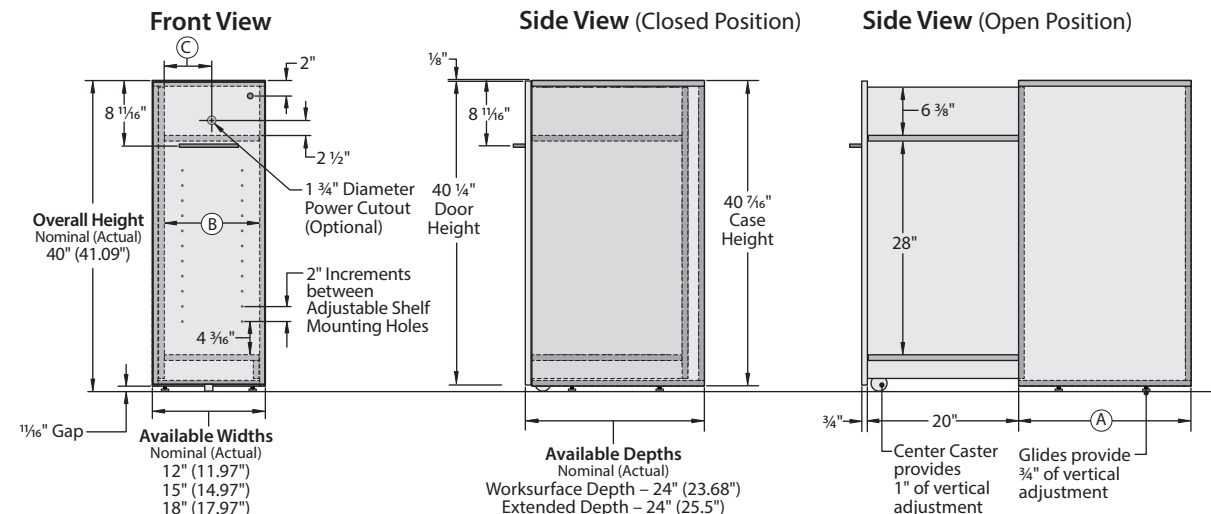

Product Details – Beside Storage

Beside Storage Pantry – 40" High

30" Deep (Closed Position)

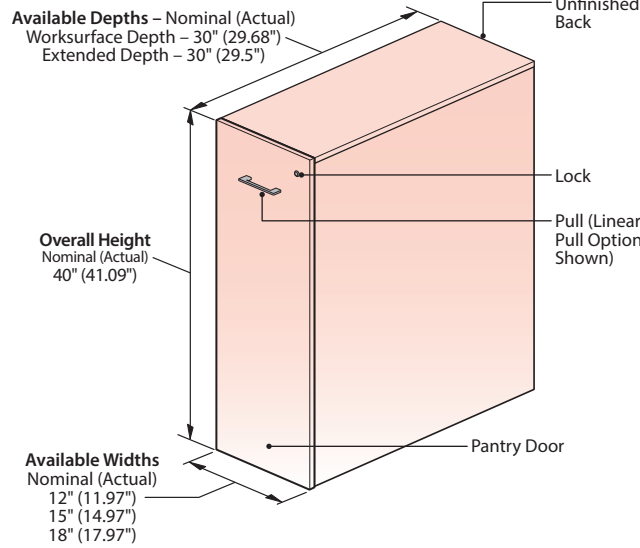

30" Deep (Open Position)

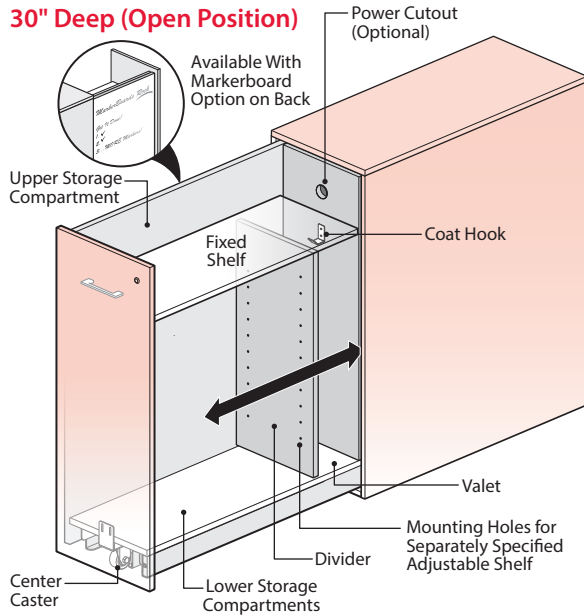

Component Materials/Finishes

COMPONENT NAME	MATERIALS/ FINISHES
Case and Pantry	Laminate Case with unfinished back and matching Laminate Pantry Interior and Laminate fixed shelf.
	Wood Case with unfinished back and specifiable Laminate Pantry Interior and laminate fixed shelf.
Pantry Door	Laminate
	Wood
Pulls	(Q) Blade Pull – Available in Trim Color
	(7) Crescent – Brushed Nickel Finish
	(8) Linear – Brushed Nickel Finish
	(9) Classic – Brushed Nickel Finish
Lock	Chrome
Coat Hook	Brushed Matte Finish

Orientation Options:

(L) Left Hand

If pantry is located on left-hand side of the user it is left-handed.

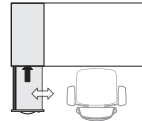

(R) Right Hand

If pantry is located on right-hand side of user it is right-handed.

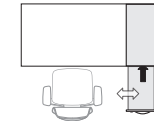

Depth Options:

Worksurface Depth

Matches Worksurface Depth.



Extended Depth

Back-to-Back Pantry condition used with a double sided benching/panel applications.

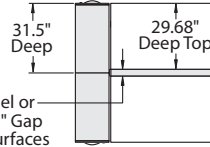

Dimensions

Overall Dimensions		Case	Pantry Interior	
Depth Nominal (Actual)	Width Nominal (Actual)	(A)	(B)	(C)
Worksurface Depth 30" (29.68")	12" (11.97")	28 13/16"	9 1/4"	4 3/8"
	15" (14.97")	28 13/16"	12 1/4"	6 1/8"
	18" (17.97")	28 13/16"	15 1/4"	7 5/8"
Extended Depth 30" (31.5")	12" (11.97")	30 11/16"	9 1/4"	4 3/8"
	15" (14.97")	30 11/16"	12 1/4"	6 1/8"
	18" (17.97")	30 11/16"	15 1/4"	7 5/8"

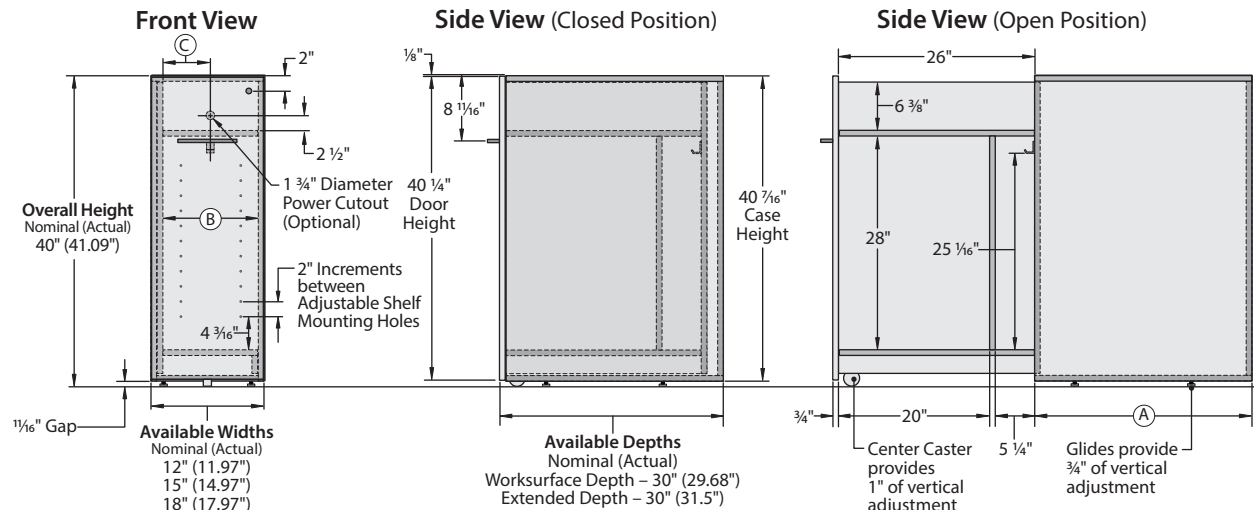

Product Details – Beside Storage

Beside Storage Pantry – 48" High

24" Deep (Closed Position)

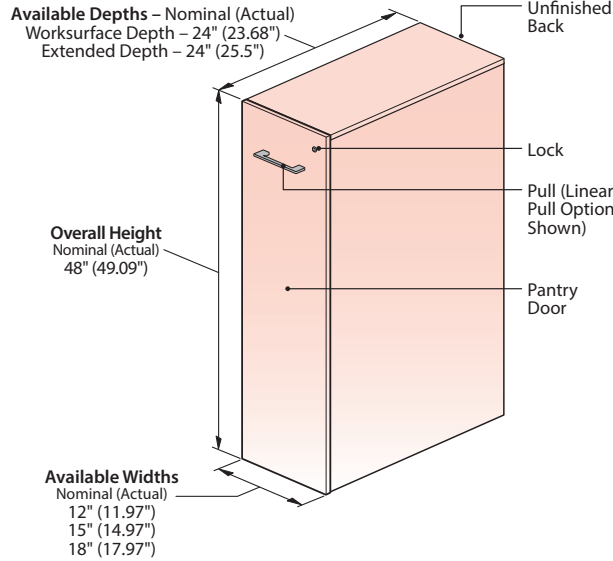

24" Deep (Open Position)

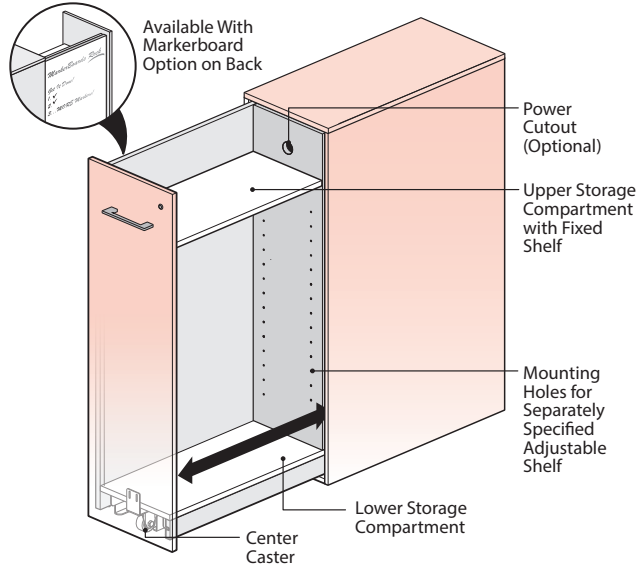

Component Materials/Finishes

COMPONENT NAME	MATERIALS/ FINISHES
Case and Pantry	Laminate Case with unfinished back and matching Laminate Pantry Interior and Laminate fixed shelf.
	Wood Case with unfinished back and specifiable Laminate Pantry Interior and laminate fixed shelf.
Pantry Door Front	Laminate
	Wood
Pulls	(Q) Blade Pull – Available in Trim Color
	(7) Crescent – Brushed Nickel Finish
	(8) Linear – Brushed Nickel Finish
	(9) Classic – Brushed Nickel Finish
Lock	Chrome

Orientation Options:

(L) Left Hand

If pantry is located on left-hand side of the user it is left-handed.

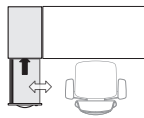

(R) Right Hand

If pantry is located on right-hand side of user it is right-handed.

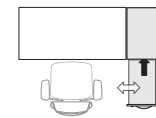

Depth Options:

Worksurface Depth

Matches Worksurface Depth.

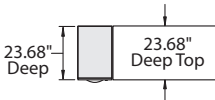

Extended Depth

Back-to-Back Pantry condition used with a double sided benching/panel applications.

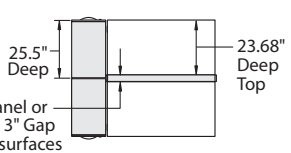

Dimensions

Overall Dimensions		Case	Pantry Interior	
Depth Nominal (Actual)	Width Nominal (Actual)	(A)	(B)	(C)
Worksurface Depth 24" (23.68")	12" (11.97")	22 13/16"	9 1/4"	4 5/8"
	15" (14.97")	22 13/16"	12 1/4"	6 1/8"
	18" (17.97")	22 13/16"	15 1/4"	7 3/8"
Extended Depth 24" (25.5")	12" (11.97")	24 1/16"	9 1/4"	4 5/8"
	15" (14.97")	24 1/16"	12 1/4"	6 1/8"
	18" (17.97")	24 1/16"	15 1/4"	7 3/8"

Front View

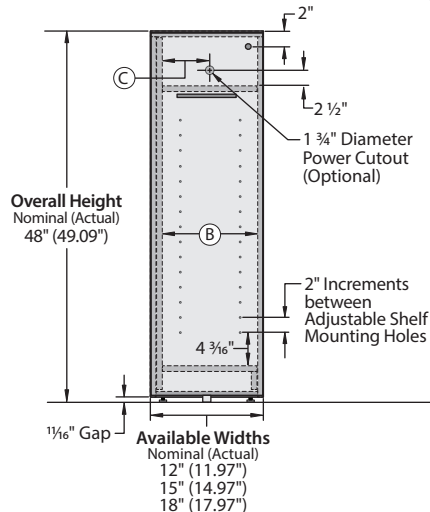

Side View (Closed Position)

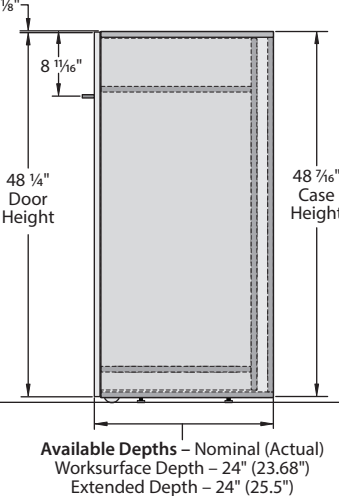

Side View (Open Position)

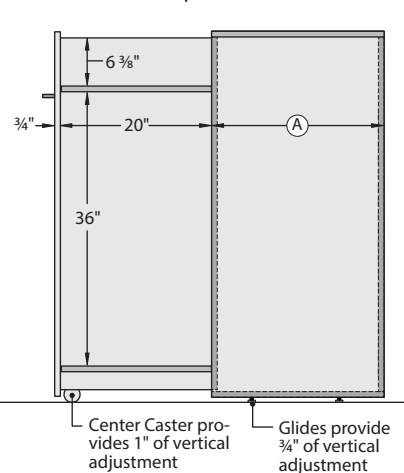

Product Details – Beside Storage

Beside Storage Pantry – 48" High

30" Deep (Closed Position)

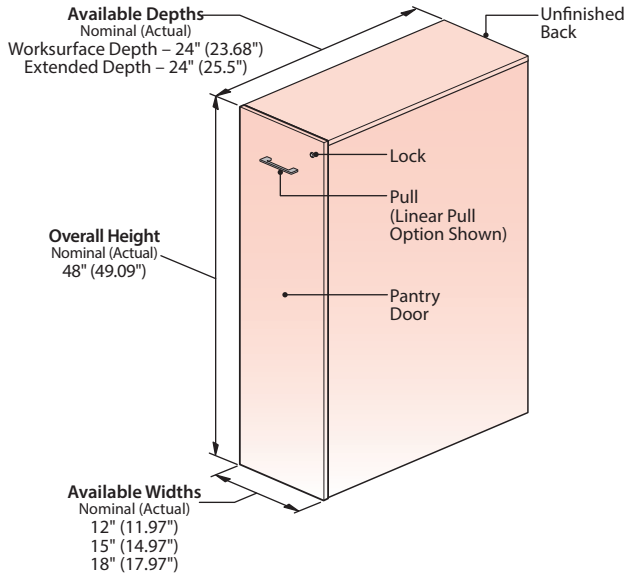

30" Deep (Open Position)

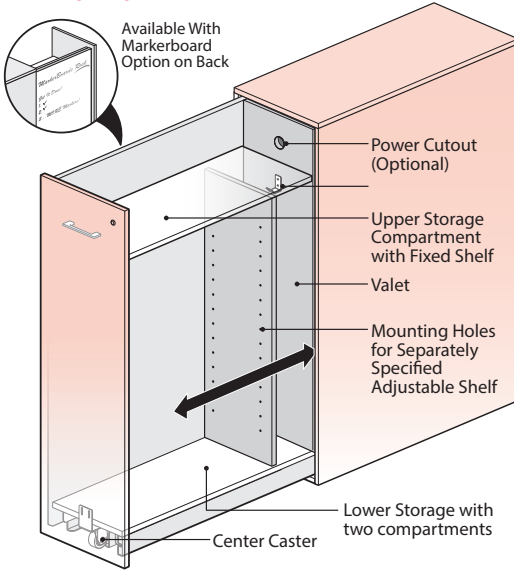

Component Materials/Finishes

COMPONENT NAME	MATERIALS/ FINISHES
Case and Pantry	Laminate Case with unfinished back and matching Laminate Pantry Interior and Laminate fixed shelf. Wood Case with unfinished back and specifiable Laminate Pantry Interior and laminate fixed shelf.
Pantry Door Front	Laminate Wood
Pulls	(Q) Blade Pull – Available in Trim Color (7) Crescent – Brushed Nickel Finish (8) Linear – Brushed Nickel Finish (9) Classic – Brushed Nickel Finish
Lock	Chrome
Coat Hook	Brushed Matte Finish

Orientation Options:

(L) Left Hand

If pantry is located on left-hand side of the user it is left-handed.

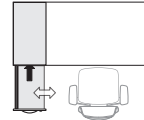

(R) Right Hand

If pantry is located on right-hand side of user it is right-handed.

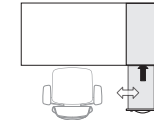

Depth Options:

Worksurface Depth

Matches Worksurface Depth.



Extended Depth

Back-to-Back Pantry condition in a double sided benching or Compose panel application.

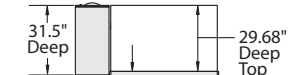

3" Compose Panel or benching with 3" Gap between worksurfaces

Dimensions

Overall Dimensions		Case	Pantry Interior	
Depth Nominal (Actual)	Width Nominal (Actual)	(A)	(B)	(C)
Worksurface Depth 30" (29.68")	12" (11.97")	28 13/16"	9 1/4"	4 5/8"
	15" (14.97")	28 13/16"	12 1/4"	6 1/8"
	18" (17.97")	28 13/16"	15 1/4"	7 3/8"
Extended Depth 30" (31.5")	12" (11.97")	30 11/16"	9 1/4"	4 5/8"
	15" (14.97")	30 11/16"	12 1/4"	6 1/8"
	18" (17.97")	30 11/16"	15 1/4"	7 3/8"

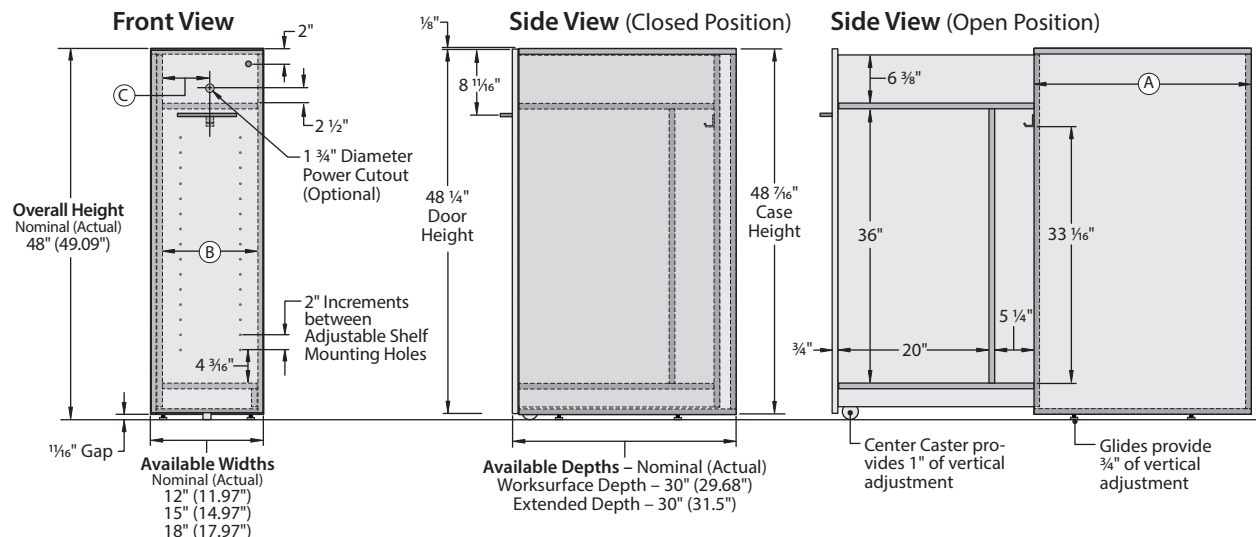

Product Details – Beside Storage

Finished Backs

- Required for applications where the back of the pantry will be visible.

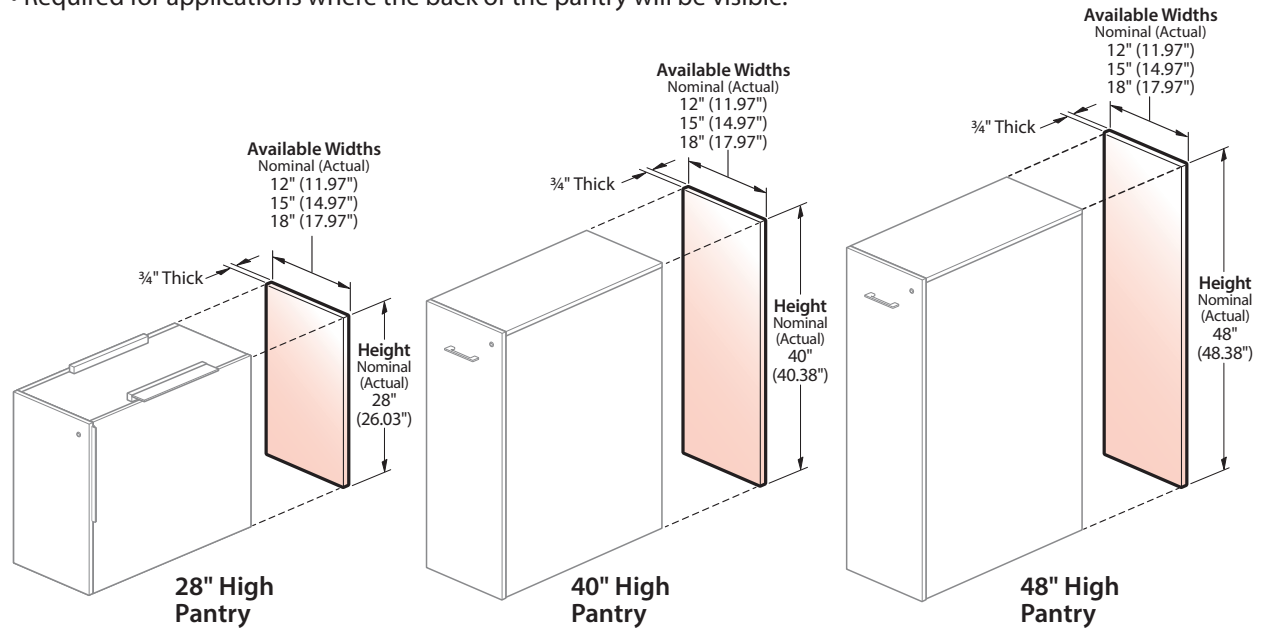

Component Materials/Finishes

COMPONENT NAME	MATERIALS/ FINISHES
Finished Back	Laminate Finish
	Wood Veneer Finish

Finished Depths

- Adds 3/4" to the finished depth of the pantry.
- The finished depth of the 28" high Pantry is different than the finished depth of the 40" and 48" high Pantries.

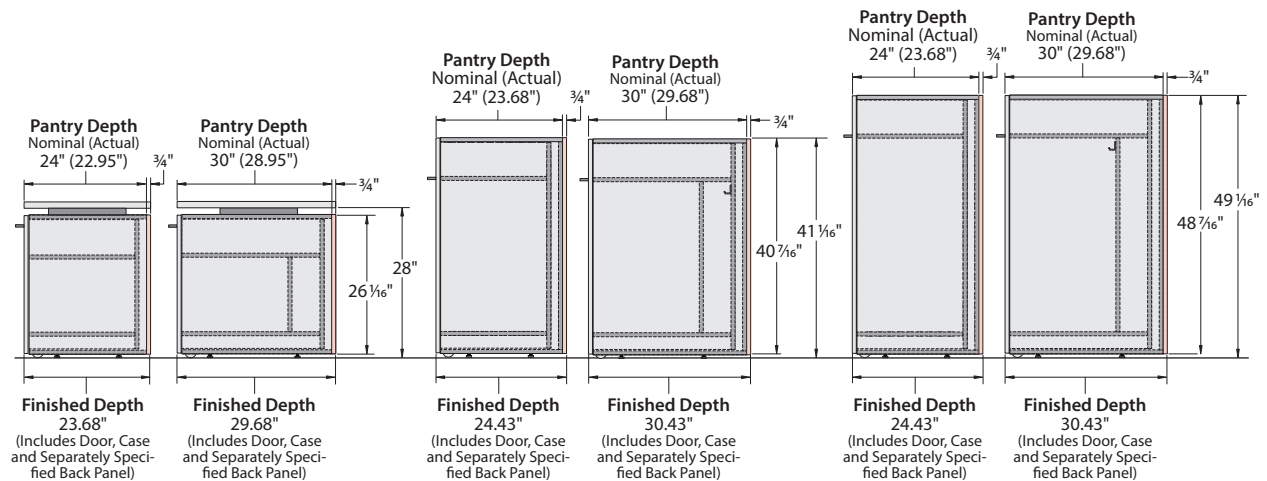

- Note**
- Once installed the finished back is not removable.
 - Power should be installed before the Finished Back is installed.

Product Details – Beside Storage

Personal Drawer

- The Personal Storage Drawer is designed for installation in the lower storage compartment of each Pantry.
- A maximum of 3 Personal Drawers are allowed per Pantry.
- The Personal Drawer may be field installed beneath the fixed shelf included with each pantry or beneath a separately specified adjustable shelf.
- Drawer is always non-locking.

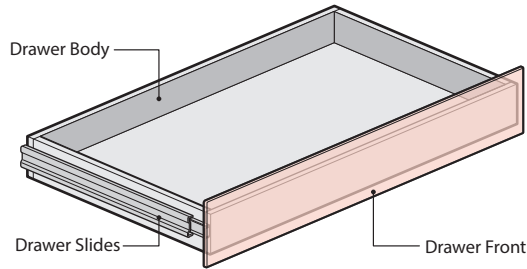

Fixed Shelf Position

- Drawer is positioned beneath the fixed shelf location.

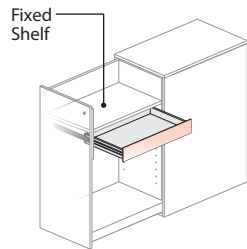

Adjustable Shelf Position

- Drawer is positioned beneath a separately specified Adjustable Shelf.
- Adjustable Shelf may be adjusted in 2" increments inside the Lower Compartment.

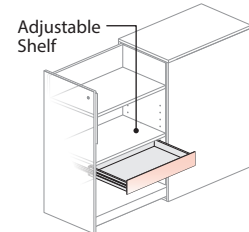

Dimensions

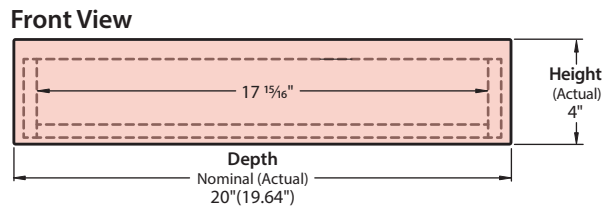
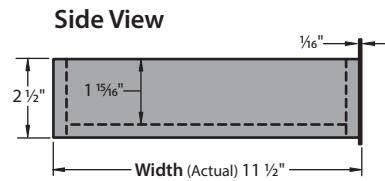

24" Deep Pantry Applications:

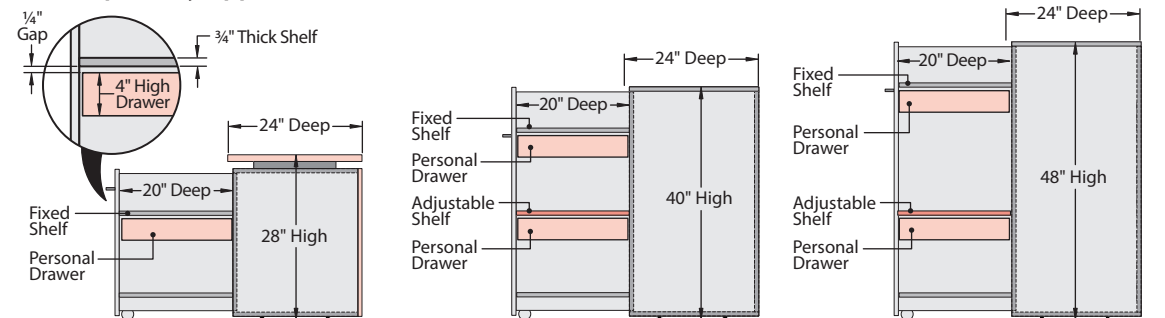

30" Deep Pantry Applications:

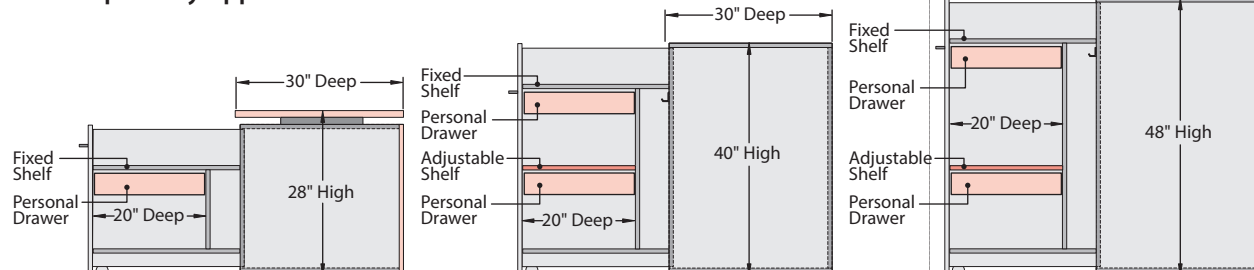

Component Materials/Finishes

COMPONENT NAME	MATERIALS/ FINISHES
Drawer Front	Painted Steel
Drawer Body	Wood Drawer

Pantry Width Restrictions:

- Personal Drawer is only for use with 15" and 18" wide Pantries.
- 12" wide Pantries are not wide enough to accommodate the Personal Drawer.



12" wide Pantries are not wide enough to accommodate the drawer.



15" wide Pantries do accommodate the drawer.



18" wide Pantries do accommodate the drawer.

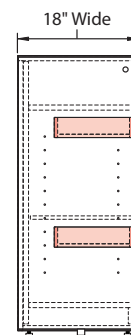
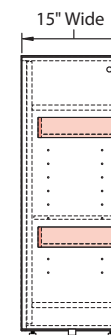
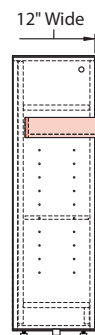

Note

- Ensure the drawer has proper clearance with adjacent furniture to open and access.

Product Details – Beside Storage

Hanging File Drawer

- The Hanging File Drawer is designed for installation in the lower storage compartment of the Pantry.
- A maximum of one Hanging File Drawers is allowed in each Pantry
- The Hanging File Drawer may be field installed beneath the fixed shelf included with each pantry or beneath a separately specified adjustable shelf.

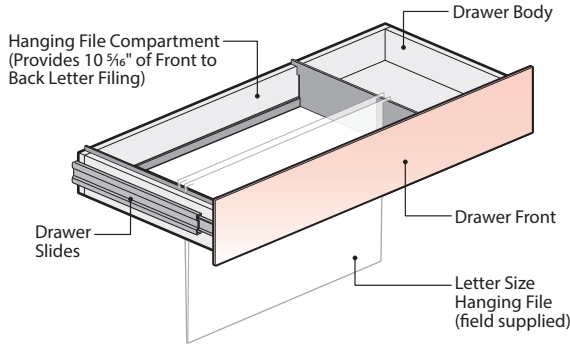

Fixed Shelf Position

- Drawer is positioned beneath the fixed shelf location.

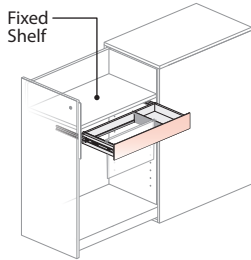

Adjustable Shelf Position

- Drawer is positioned beneath a separately specified Adjustable Shelf.
- Adjustable Shelf may be adjusted in 2" increments inside the Lower Compartment.

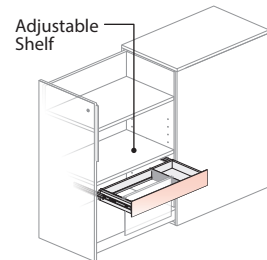

Component Materials/Finishes

COMPONENT NAME	MATERIALS/ FINISHES
Drawer Front	Painted Steel
Integrated File Hanging Bars	Painted Steel (Same as Drawer Front)
Drawer Body	Wood Drawer

Pantry Width Restrictions:

- Hanging File Drawer is only for use with 15" and 18" wide Pantries.
- 12" wide Pantries are not wide enough to accommodate the Personal Drawer.



Don't
12" wide Pantries are not wide enough to accommodate the drawer.



Do
15" wide Pantries do accommodate the drawer.



Do
18" wide Pantries do accommodate the drawer.

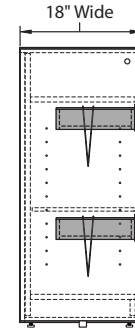
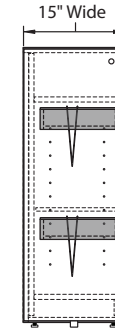
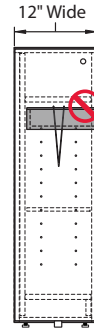

Note

- Ensure the drawer has proper clearance with adjacent furniture to open and access.

Dimensions

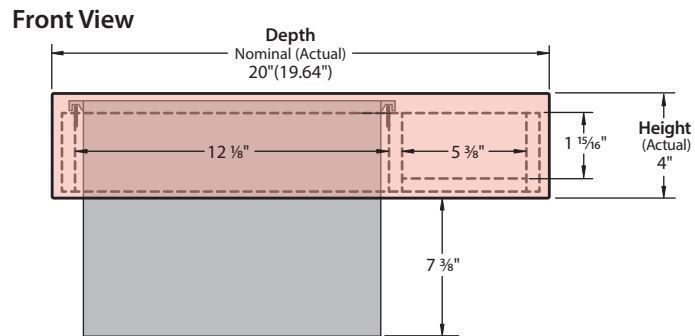
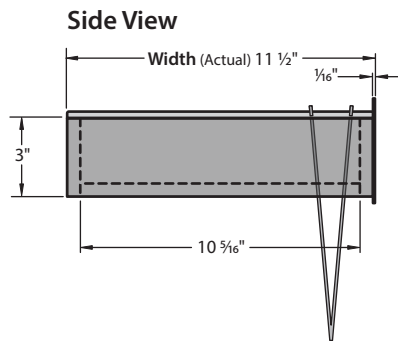

24" or 30" Deep Pantry Applications:

- The Hanging File Drawer is designed for either 24" or 30" deep pantries.

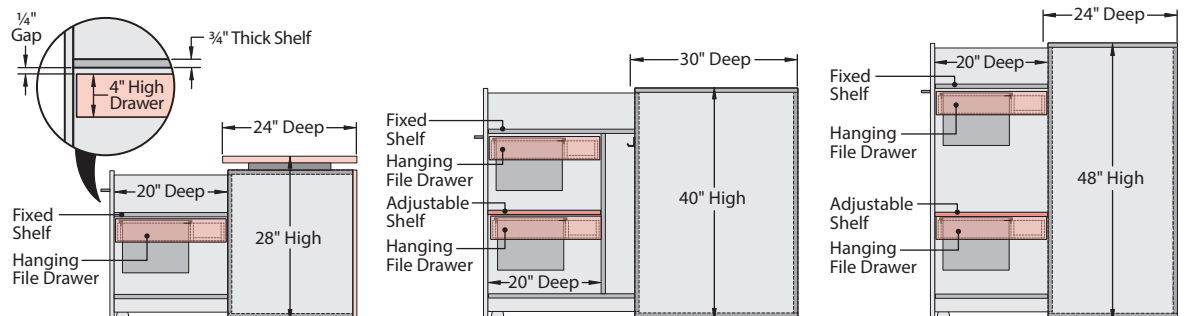

Product Details – Beside Storage

Adjustable Shelf

- The Adjustable Shelf is designed for installation in the lower storage compartment of the Pantry.
- The Adjustable Shelf may be adjusted in 2" increments inside the Lower Compartment of the Pantry.

Component Materials/Finishes

COMPONENT NAME	MATERIALS/ FINISHES
Adjustable Shelf	Painted Steel

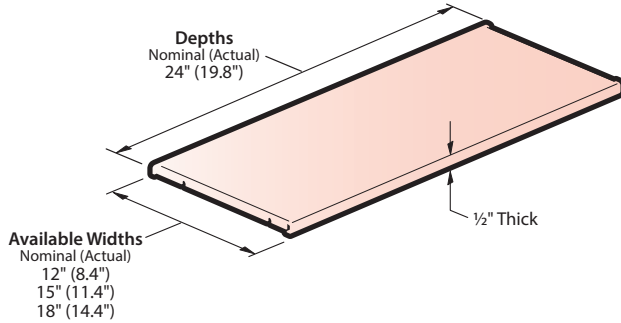

Adjustable Shelf Pantry Applications:

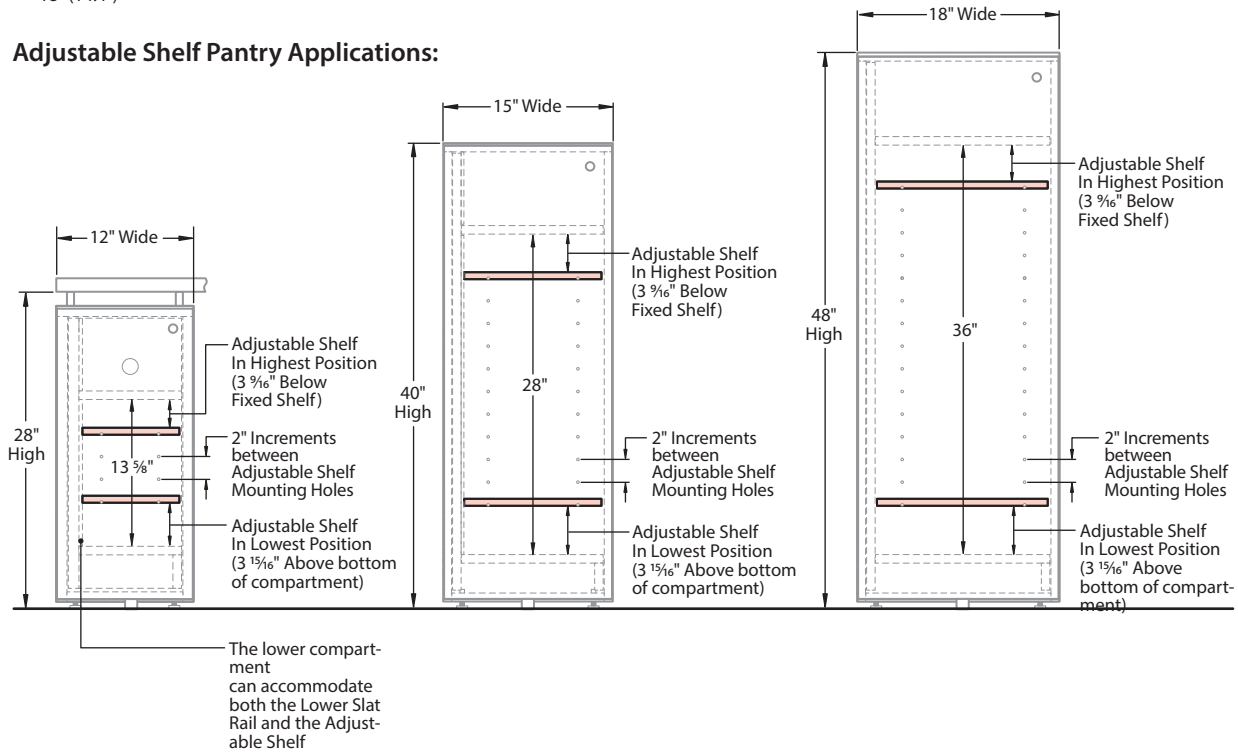

Product Details – Beside Storage

Upper Slat Rail

- The Upper Slat Rail attaches above the fixed shelf inside the Beside Pantry.
- compatible Belong Accessories.
- For use on 28", 40" or 48" high storage pantries.

Component Materials/Finishes

COMPONENT NAME	MATERIALS/ FINISHES
Slat Rail	Painted Steel

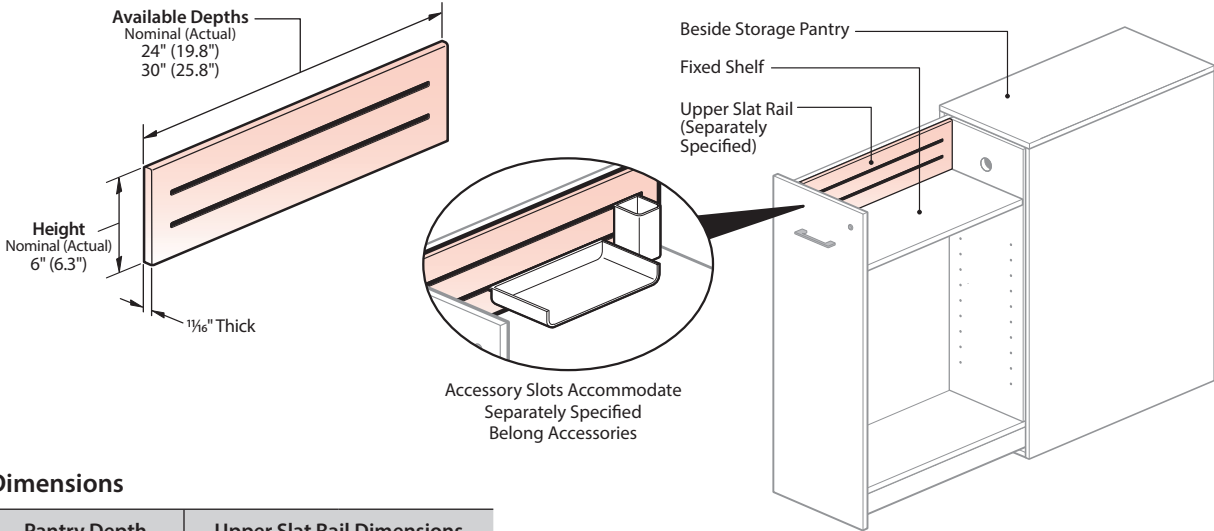

Dimensions

Pantry Depth	Upper Slat Rail Dimensions	
	(A) Slat Rail Depth Nominal (Actual)	(B) Slot Depth
Worksurface Depth 24" (23.68")	24" (19.8")	16 13/16"
Extended Depth 24" (24.5")	24" (19.8")	16 13/16"
Worksurface Depth 30" (29.68")	30" (25.8")	22 13/16"
Extended Depth 30" (31.5")	30" (25.8")	22 13/16"

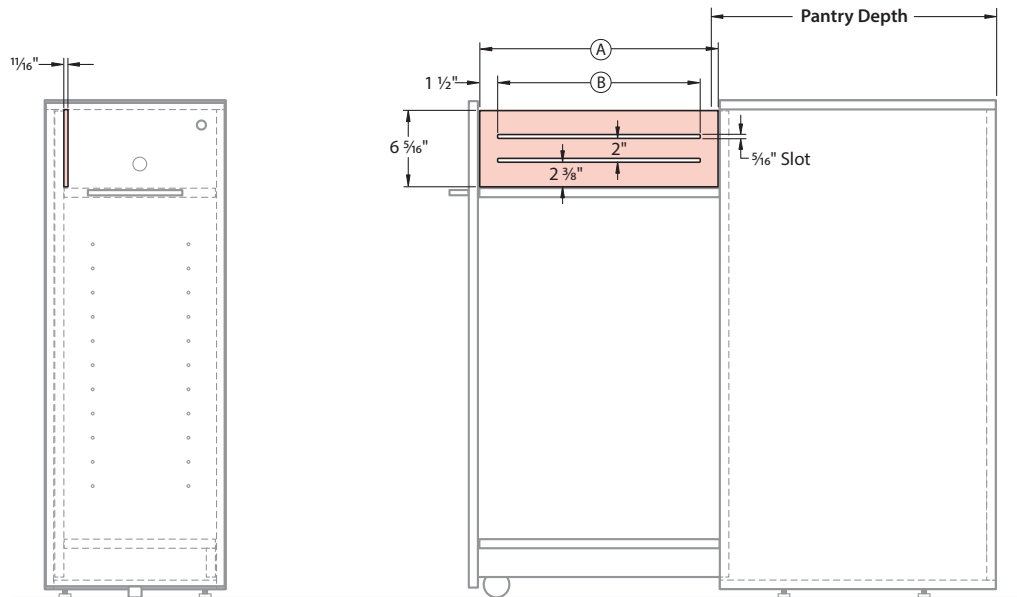

- Note**
- The Belong Tool Cup can not be used on the lower accessory slot.
 - The Belong Hanging Sorter will not work with the Upper Slat Rail.
 - The Belong Paper Tray (Hanging/Slat Mounted) will not work with the 12" Wide Beside Storage Pantries.

Product Details – Beside Storage

Lower Slat Rail

- The Lower Slat Rail attaches below the fixed shelf inside the Beside Pantry.
- The accessory slots allow the attachment of compatible Belong Accessories.
- For use on 40" or 48" high storage pantries only.

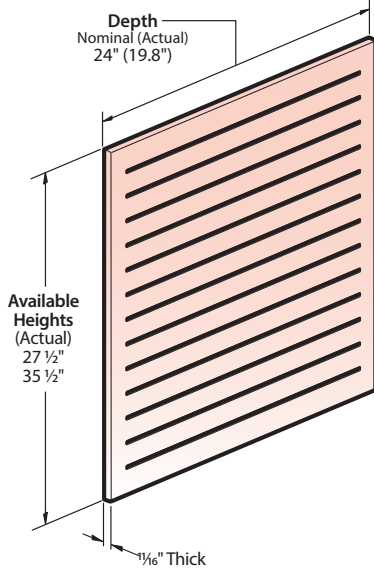

Dimensions

Pantry Dimensions		Lower Slat Rail Dimensions
Height Nominal (Actual)	Depth Nominal (Actual)	Ⓐ Slat Rail Height
40" (41.09")	Worksurface Depth 24" (23.68")	27 1/2"
	Extended Depth 24" (24.5")	27 1/2"
48" (49.09")	Worksurface Depth 30" (29.68")	35 1/2"
	Extended Depth 30" (31.5")	35 1/2"

Component Materials/Finishes

COMPONENT NAME	MATERIALS/ FINISHES
Slat Rail	Painted Steel

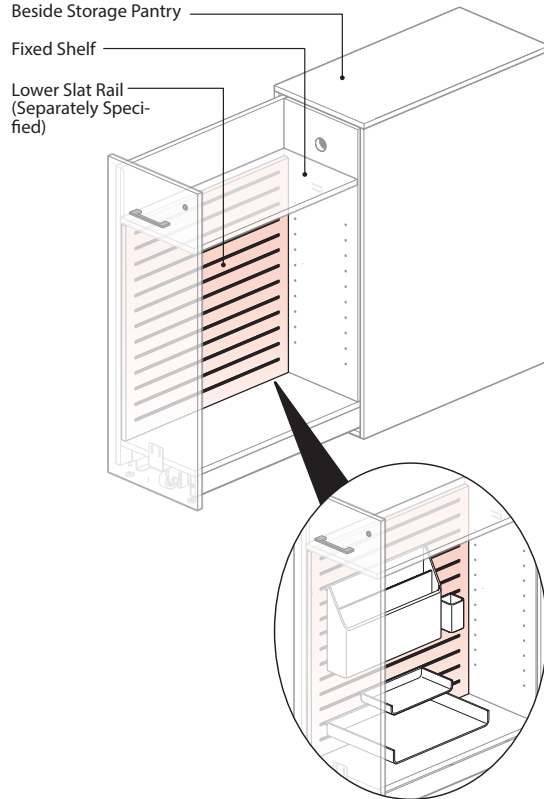

Accessory Slots Accommodate Separately Specified Belong Accessories

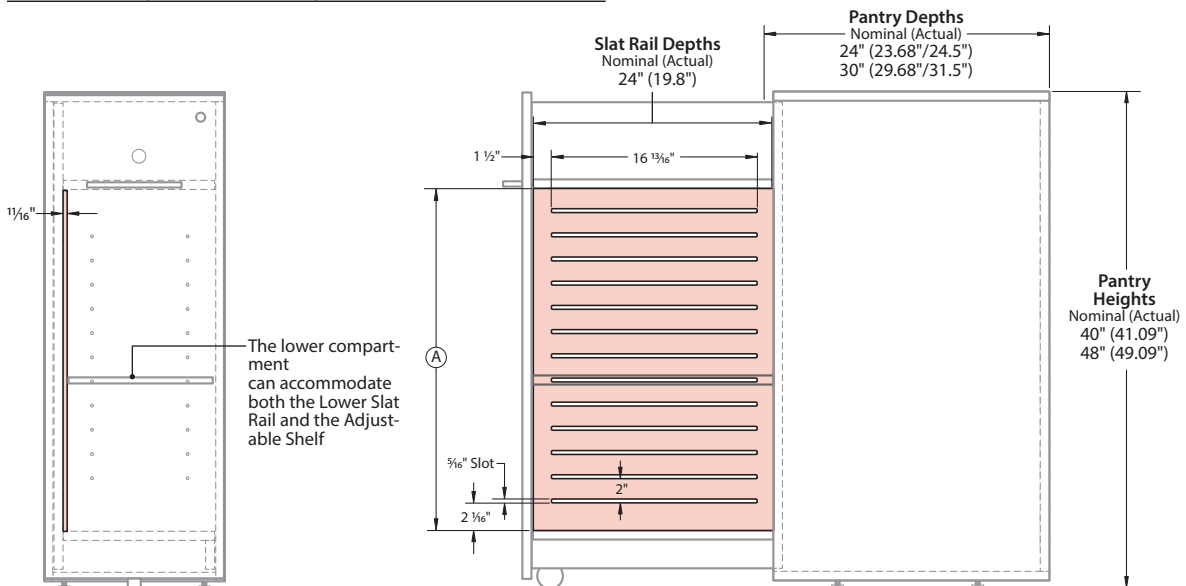

Note • The Belong Paper Tray (Hanging/Slat Mounted) will not work with the 12" Wide Beside Storage Pantries.

Product Details – Beside Storage

Saddle

- The Saddle extends down over one side of the Beside Pantry case.
- Accessory Slot accommodates Belong hanging accessories.
- For use on 40" or 48" high storage pantries only.

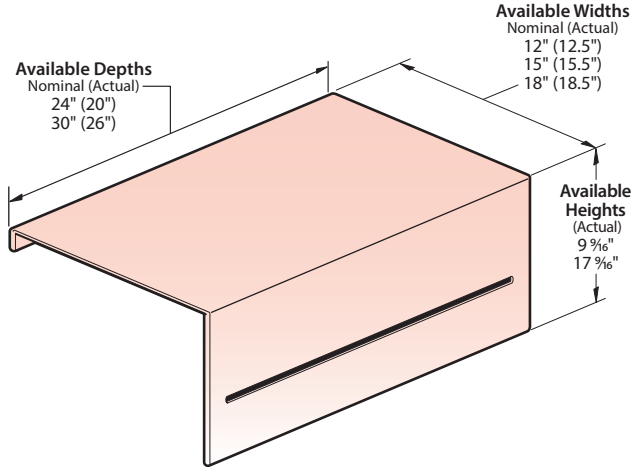

Component Materials/Finishes

COMPONENT NAME	MATERIALS/ FINISHES
Saddle	Painted Steel

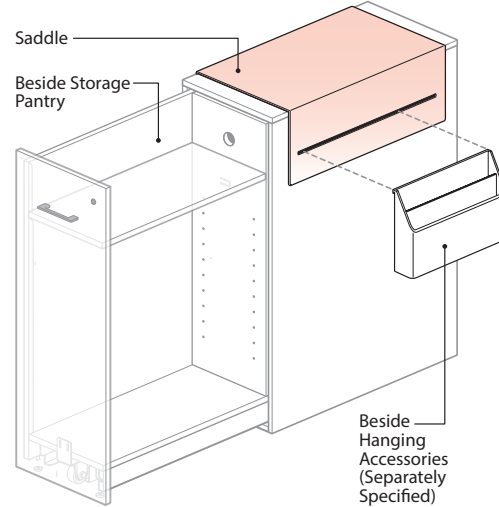

Dimensions

Pantry Dimensions			Saddle Dimensions			
Height (Actual)	Depth Nominal (Actual)	Width Nominal (Actual)	Ⓐ Saddle Width Nominal (Actual)	Ⓑ Saddle Depth Nominal (Actual)	Ⓒ Saddle Height (Actual)	Ⓓ
40"	Worksurface Depth 24" (23.68")	12" (11.97")	12" (12.5")	24" (20")	9 1/2"	17"
	Extended Depth 24" (25.5")	15" (14.97")	15" (15.5")	24" (20")	9 1/2"	17"
	Extended Depth 24" (25.5")	18" (17.97")	18" (18.5")	24" (20")	9 1/2"	17"
	Worksurface Depth 30" (29.68")	12" (11.97")	12" (12.5")	30" (26")	9 1/2"	23"
	Extended Depth 30" (31.5")	15" (14.97")	15" (15.5")	30" (26")	9 1/2"	23"
	Extended Depth 30" (31.5")	18" (17.97")	18" (18.5")	30" (26")	9 1/2"	23"
48"	Worksurface Depth 24" (23.68")	12" (11.97")	12" (12.5")	24" (20")	17 1/2"	17"
	Extended Depth 24" (25.5")	15" (14.97")	15" (15.5")	24" (20")	17 1/2"	17"
	Extended Depth 24" (25.5")	18" (17.97")	18" (18.5")	24" (20")	17 1/2"	17"
	Worksurface Depth 30" (29.68")	12" (11.97")	12" (12.5")	30" (26")	17 1/2"	23"
	Extended Depth 30" (31.5")	15" (14.97")	15" (15.5")	30" (26")	17 1/2"	23"
	Extended Depth 30" (31.5")	18" (17.97")	18" (18.5")	30" (26")	17 1/2"	23"

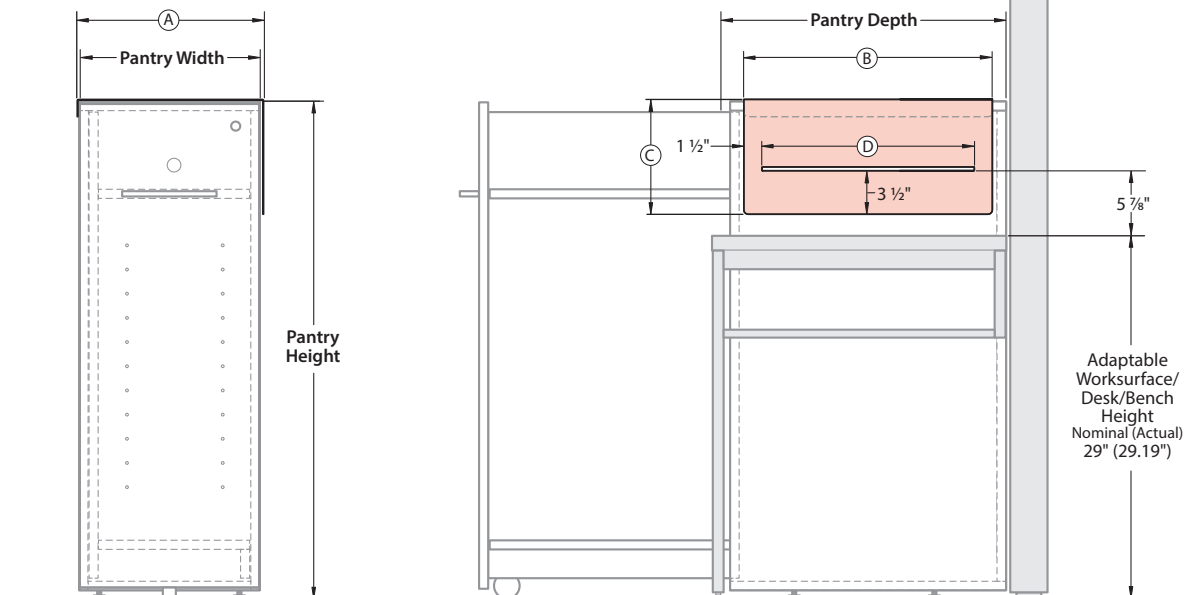

Product Details – Beside Storage

Brackets

Adaptable WS Bracket

- Two ZUBW-0000-PN brackets are used to attach one end of an Adaptable Worksurface in an off modular worksurface condition in a Compose panel application. The back of the off-modular worksurface must also be attached to the panel with a worksurface support bracket.

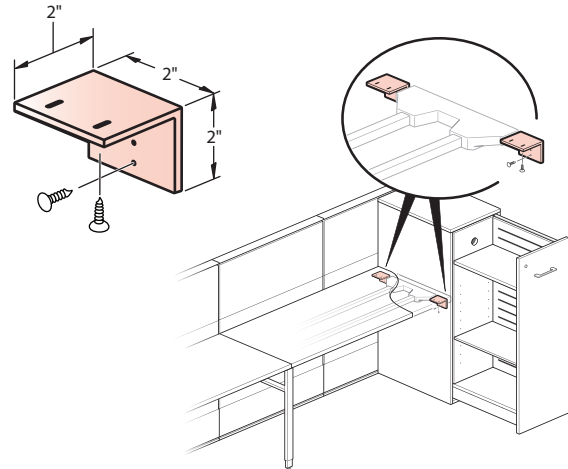

Component Materials/Finishes

COMPONENT NAME	MATERIALS/ FINISHES
Adaptable Worksurface	Painted Metal – Standard in Black

Reside without legs/Adaptable Rectangular Convergent Worksurface Bracket

- Two ZUBT-0307-PN brackets are used in the following conditions:
 - To attach one end of an Adaptable rectangular convergent worksurface with a maximum width of 60" in a nonpanel based application. Opposite end requires a floor support option or to be attached to another storage pantry.
 - In place of Reside support legs to attach one end of a Reside worksurface to a storage pantry.
 - When passing power through storage pantry or pantries to another Reside worksurface.

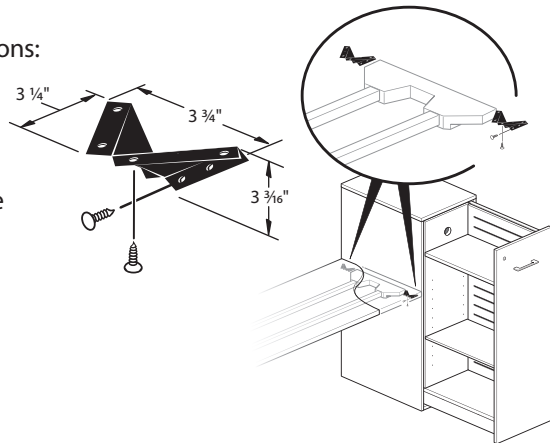

Component Materials/Finishes

COMPONENT NAME	MATERIALS/ FINISHES
Reside without legs/Adaptable Rectangular Convergent WS	Painted Metal – Standard in Black

Reside with Legs Bracket

- Two ZKBG-0000-PN brackets are used to attach one end of an Reside Worksurface in conjunction with Reside support legs adjacent to the storage pantry in the following conditions:
 - When passing power through storage pantry or pantries to another Reside worksurface.
 - To support a 12" wide storage pantry if field supplied ganging hardware is not applicable.

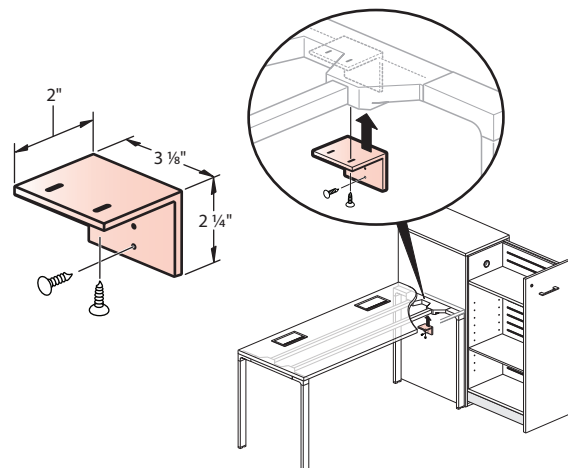

Component Materials/Finishes

COMPONENT NAME	MATERIALS/ FINISHES
Reside with Legs Bracket	Painted Metal

Product Details – Beside Storage

Brackets

Intuity Bracket

- Two ZBBG-0000-PN brackets are used to attach one end of an Intuity Worksurface in conjunction with Intuity support legs adjacent to the storage pantry in the following conditions:
 - When passing power through storage pantry or pantries to another Intuity worksurface.
 - To support a 12" wide storage pantry if field supplied ganging hardware is not applicable.

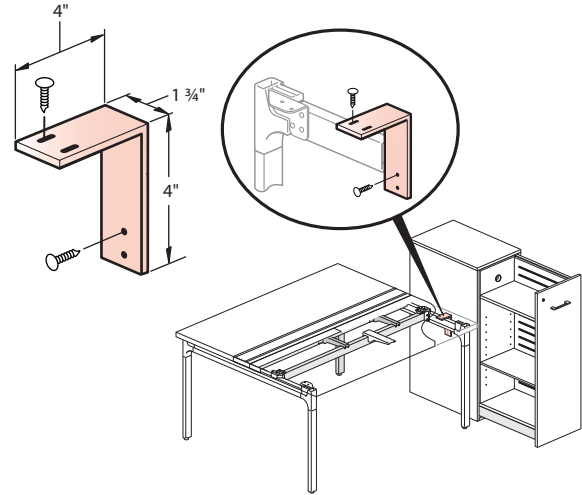

Component Materials/Finishes

COMPONENT NAME	MATERIALS/ FINISHES
Intuity Bracket	Painted Steel

Planes Height Adjustable Table – Bench Bracket

- Two ZTBG-0000-PN brackets are used to attach one end of an Planes Height Adjustable Table - Bench worksurface in the following conditions:
 - When passing power through storage pantry or pantries to another Planes Height Adjustable Table - Bench worksurface.
 - To support a 12" wide storage pantry if field supplied ganging hardware is not applicable.

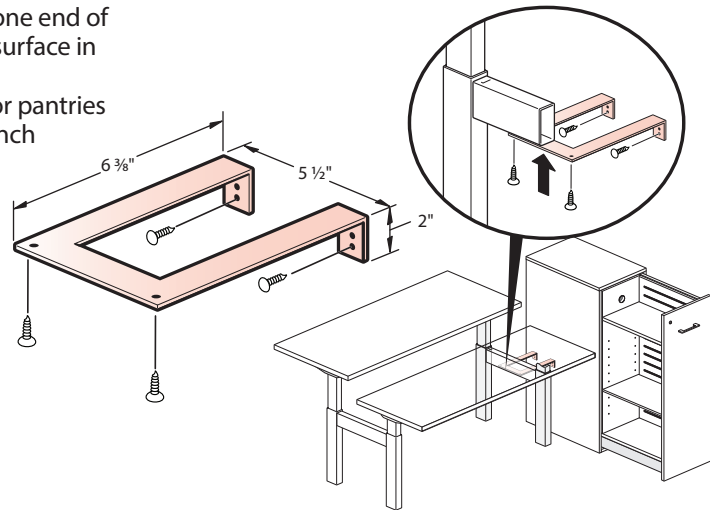

Component Materials/Finishes

COMPONENT NAME	MATERIALS/ FINISHES
Planes Height Adjustable Table – Bench Bracket	Painted Steel

Compose Panel to Pantry Bracket

- Allows a 28", 40" or 48" high Beside Storage Pantry to be attached to a Compose Panel.
- Panels must be equal in height or taller than height of Beside Storage Pantry.
- Installs in panel frame slots and attaches to the back corner of the Storage Pantry (requires drilling).
- Not for use with Finished Back.

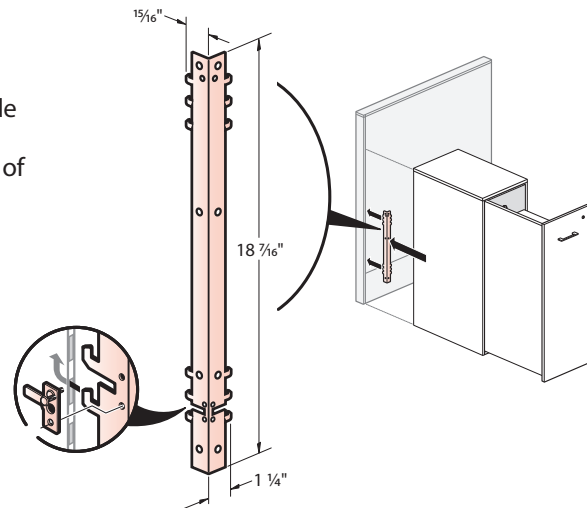

Component Materials/Finishes

COMPONENT NAME	MATERIALS/ FINISHES
Compose Bracket	Painted Steel

Product Details – Beside Storage

Bezel Utility Module

- Includes a round faced module with two USB ports, 12' cord with a voltage transformer and plug.
- Each USB port provides 1000 mA of charging power (5 volts).
- Installation requires the Beside Storage Pantry be specified with the optional Power Cutout.

Bezel Utility Module

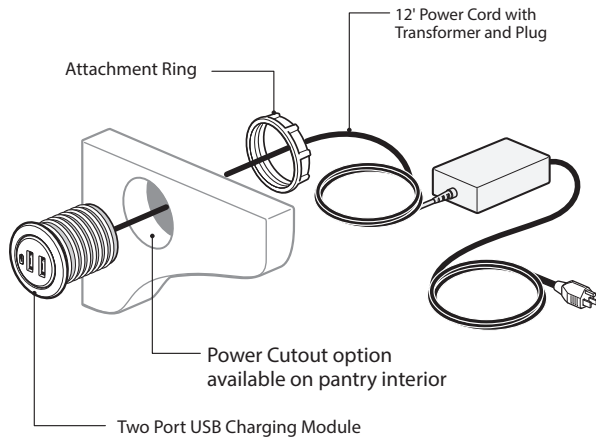

Component Materials/Finishes

COMPONENT NAME	MATERIALS/ FINISHES
Two Port USB Charging Module	Black or White Finish
12' Power Cord with Transformer and Plug	Black
Transformer Mounting Bracket	Black

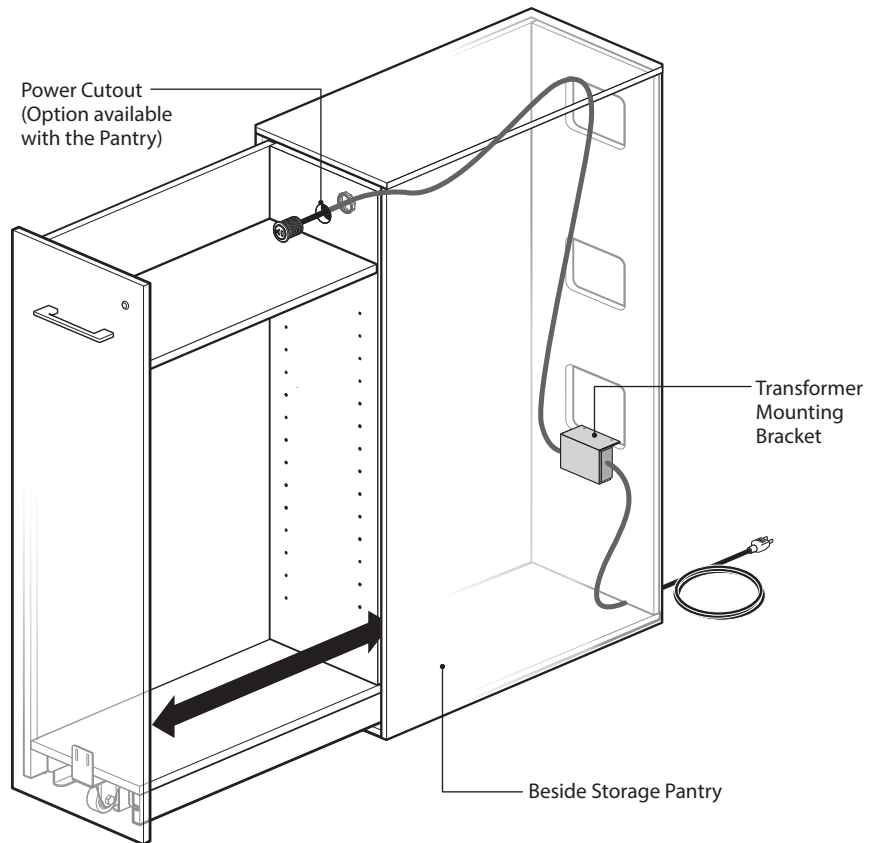

Product Details – Beside Storage

Grommet

- Field installed Grommet is required for applications where Jumpers are run through the back of the pantry to route power between adjacent worksurfaces.
- The grommet is standard in black and is used to finish the field installed cutout used for routing a jumper through the back of the pantry.

Component Materials/Finishes

COMPONENT NAME	MATERIALS/ FINISHES
Grommet	Plastic – Standard in Black

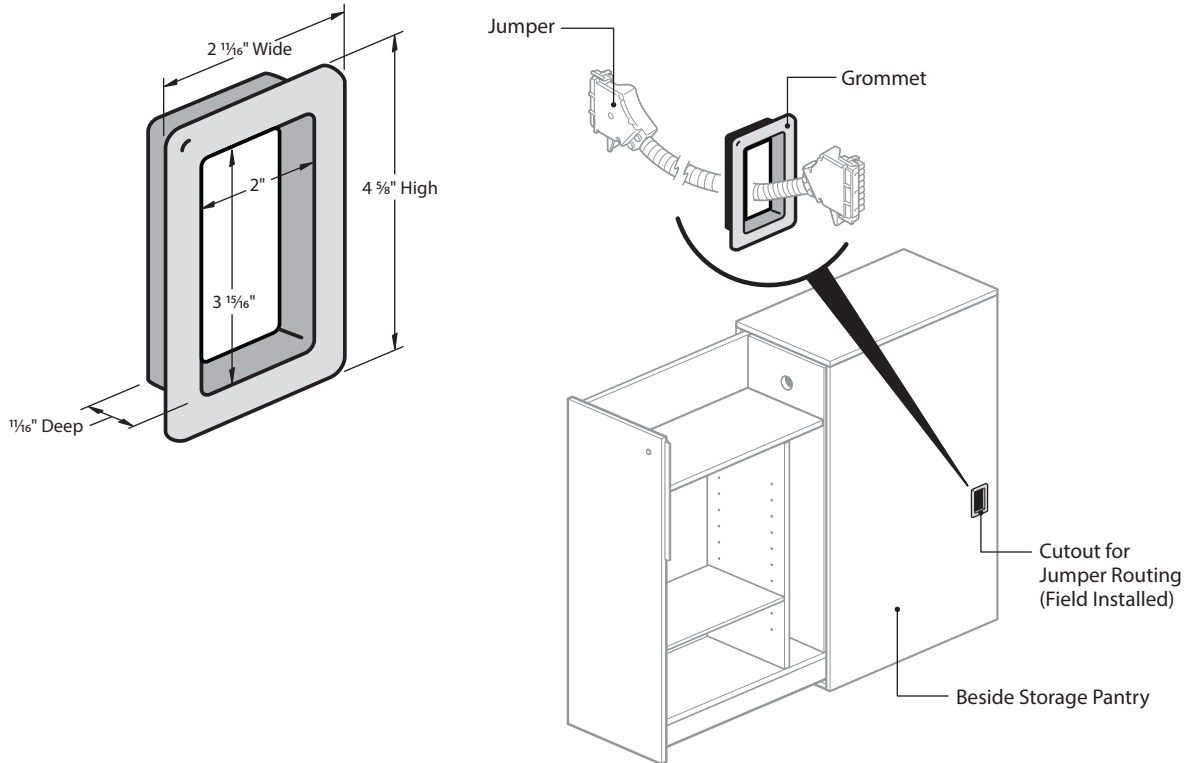

Product Details – Beside Storage

Digital Locks

- Includes:
 - Digital lock with 5-digit horizontal or vertical keypad and rotating lock knob
 - CR2032 3-volt lithium battery
 - Factory-assigned access code
 - Attachment hardware and spacer for metal and wood surfaces
- Fits the standard lock housing available with the Beside Storage Pantry.
- Lock may be specified with 90° or 180° knob rotation
- Two software versions allow the lock to be programmed by individual users each time it's used, or by a facility manager for workstations where re-programming is infrequent.

Component Materials/Finishes

COMPONENT NAME	MATERIALS/ FINISHES
Housing and Knob	Black or Brushed Chrome

Horizontal Digital Lock Knob on Left Side

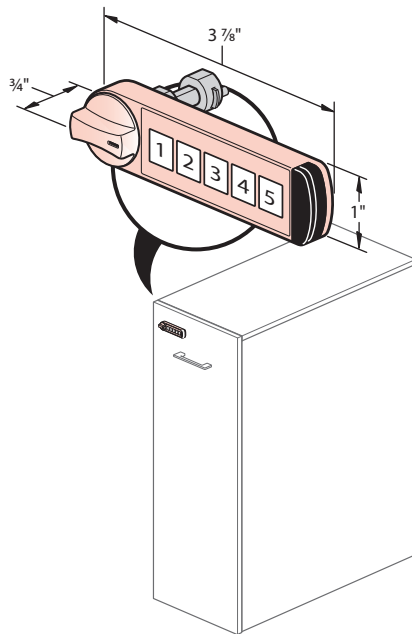

Horizontal Digital Lock Knob on Right Side

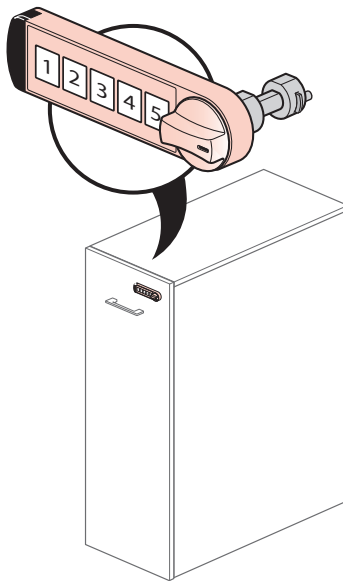

Vertical Digital Lock Knob on Top

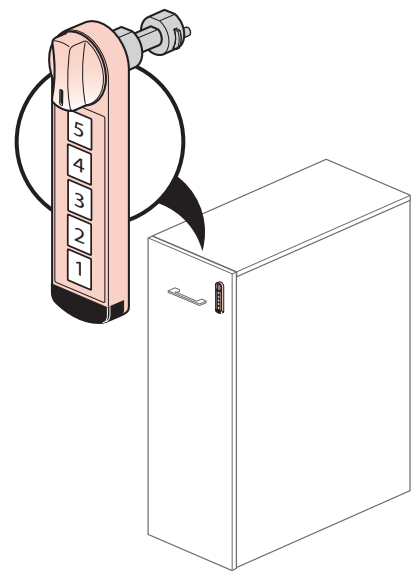

Don't

Vertical Digital Lock Knob on Bottom

- The Vertical Digital Lock with Knob on Bottom is not for use the Beside Storage Pantry since the Lock would stick up past the top of the pantry when installed.

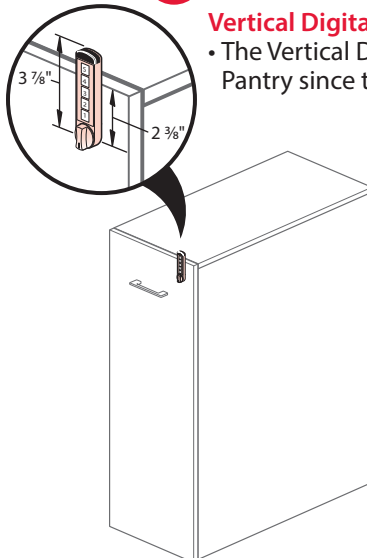

Product Details – Beside Storage

Pull Options – Blade Pull

Blade Pull Option (Q) – with 28" High Storage Pantry

- The drawer pulls for 28" high Storage Pantries are mounted on the top of the pull out drawer front.

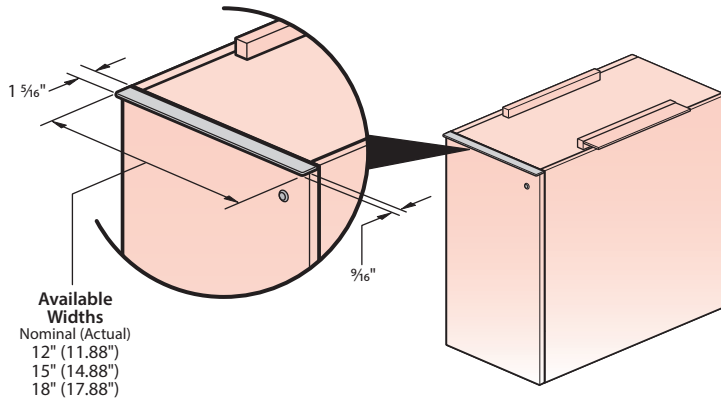

Blade Pull Option (Q) – with 40" High Storage Pantry

- The drawer pulls for 40" high Storage Pantries are mounted on the side of the pull out drawer front.

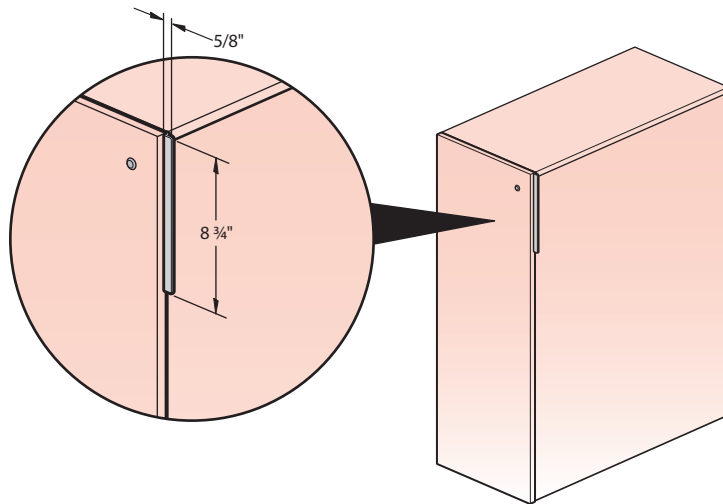

Blade Pull Option (Q) – with 48" High Storage Pantry

- The drawer pulls for 48" high Storage Pantries are mounted on the side of the pull out drawer front.

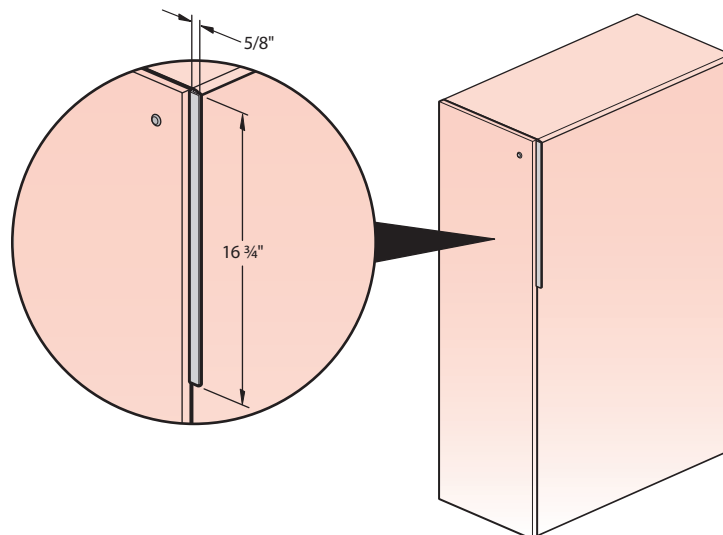

Product Details – Beside Storage

Pull Options

Crescent Pull (7), Linear Pull (8) and Classic Pull (9)

- The Crescent, Linear and Classic Pulls are mounted on the Storage Pantry Pull Out Drawer front.
- Each of the pulls have a brushed nickel finish.



Crescent Pull (7)

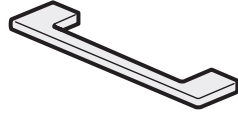

Linear Pull (8)

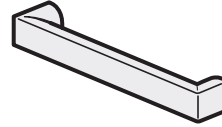

Classic Pull (9)

Storage Pantry Pull Locations

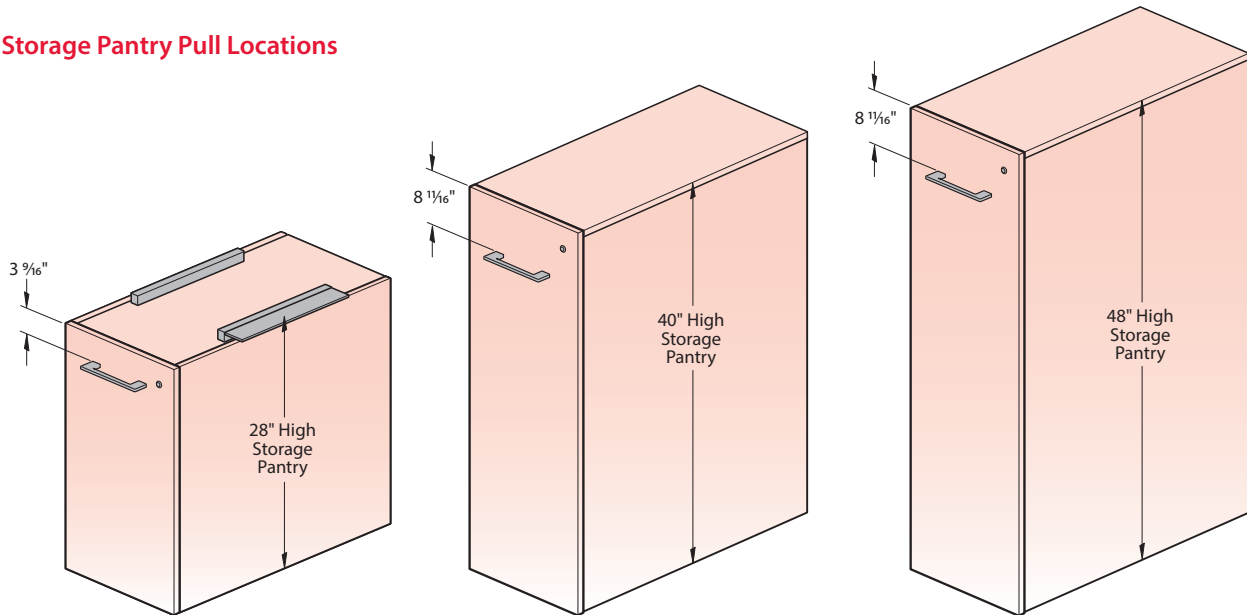

Product Details – Beside Storage

Wood Grain Direction

Natural Veneer

Vertical Surfaces – Wood grain direction runs vertically on the case, door and finished back.

Horizontal Surfaces – Wood grain direction runs side-to-side on case tops.

Natural Wood Veneer

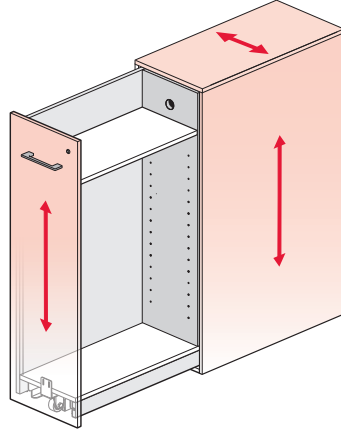
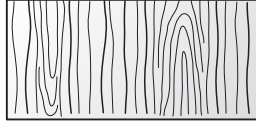

Double Cut Veneer

Vertical Surfaces – Wood grain direction runs horizontally on case, door and finished back.

Horizontal Surfaces – Wood grain direction runs side-to-side on case tops.

Double Cut Wood Veneer

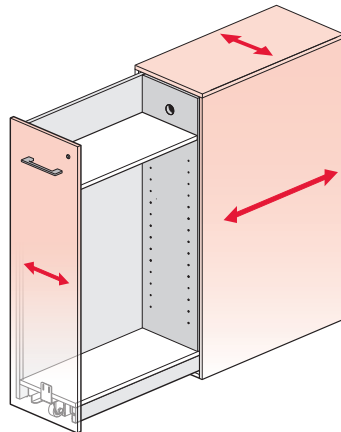
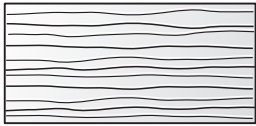

Wood Grain Laminate

Vertical Surfaces – Wood grain direction runs vertically on the case, door, pantry interior and the finished back.

Horizontal Surfaces – Wood grain direction runs side-to-side on the case tops and front-to-back on shelves.

Woodgrain Laminate

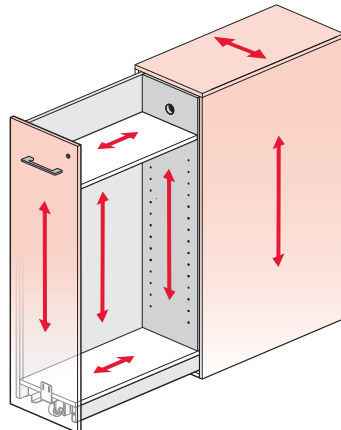
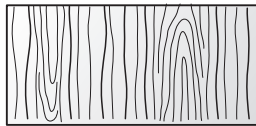

Product Application Beside Storage

Product Application – Beside Storage

Storage Attachment Guidelines – Planning Model Overview

For Base Unit attachment planning purposes there are two functional categories. The first functional type is a Base Unit with drawers; includes box or file drawers. The second functional type is all other Base Unit configurations; includes open, single and double sliding doors and hinged doors. For double or triple Base Units configured with an open, slider or hinged door portion and a box or lateral drawer portion default to the drawer portion of the Base Unit to apply attachment guidelines.

- All Beside Base Units with a box or file drawer must be attached.
- Beside Base Unit 42" wide or less must be attached.
- Beside Base Unit 48" wide or greater without a box or lateral drawer may be freestanding.

Type A Base Units – Any Base Unit CONTAINING box drawers or file drawers.

Functional Base Unit TYPE

(A)

✓ **Must Be ATTACHED** – All widths

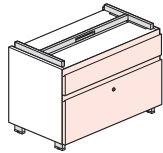

Any Single Width with File Drawer

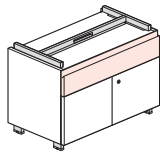

Any Single Width with Box Drawer

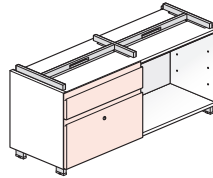

Double Width with Box or File Drawer

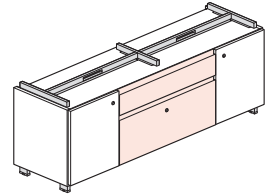

Triple Width with Box or File Drawer

TYPE B Base Units – Any Base Unit NOT CONTAINING box drawers or file drawers.

Functional Base Unit TYPE

(B)

✓ **Must Be ATTACHED** – Widths of 42" or Less

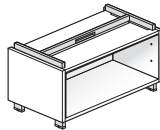

Single Width Open Under 42"

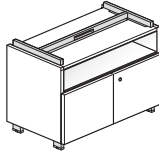

Single Width Hinged Doors Under 42"

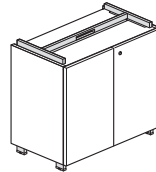

Single Width Hinged Doors Under 42"

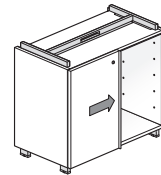

Single Width Sliding Door Under 42"

✓ **May Be FREESTANDING** – Widths of 48" or Greater

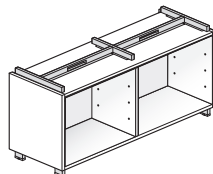

Double Width Open Over 48"

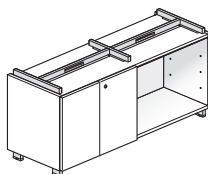

Double Width Hinged Doors Over 48"

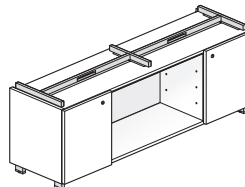

Triple Width Hinged Doors Over 48"

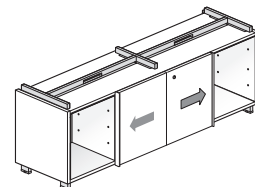

Triple Width Sliding Door Over 48"

Product Application – Beside Storage

Storage Attachment Guidelines – Planning Model Overview

There are several attachment options for Beside Base Units. Attachment options include Ganging Bracket Kit, Storage Attachment Bracket, Desk-to-Storage Bracket, Flush Mount Plate and Storage-to-Panel Bracket.

In addition to type A and B functional Base Units the Base Unit height and planning models are key factors in determining valid attachment options. Base Unit Planning Model Overview shown below:

Base Unit Attachment Options:

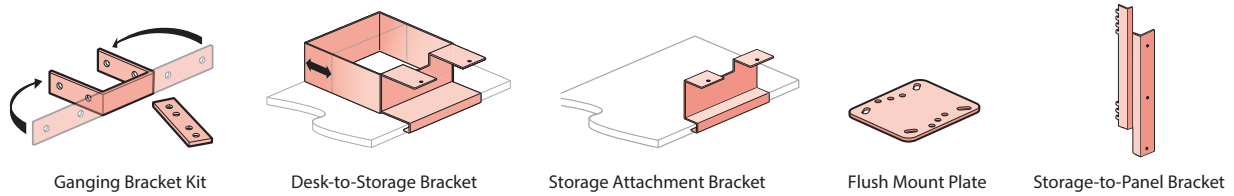

In-Line Base Units – Planning Models:

Two Base Units:

Single Sided Access

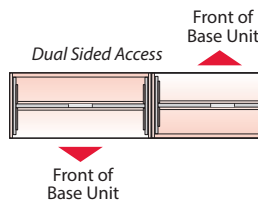
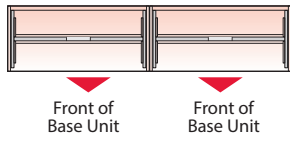

Three Base Units:

Single Sided Access

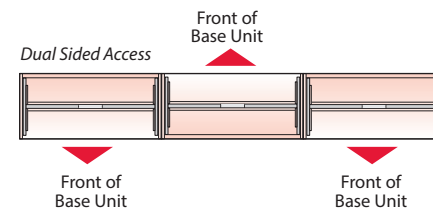
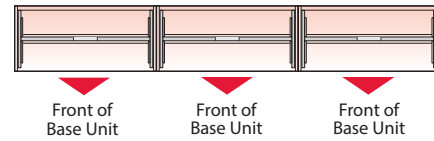

Back-To-Back Base Units – Planning Model:

Back-To-Back Base Units:

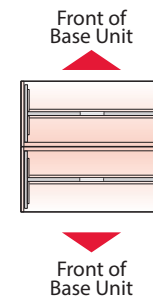

Storage Based – Planning Model – With Beside Base Units

One-and-One-Half High Base Units

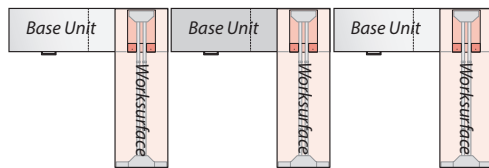

Two High Base Units

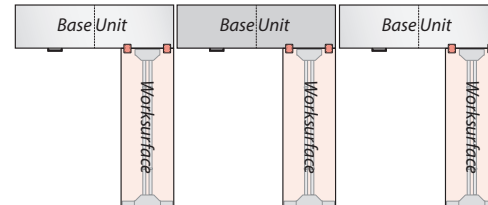

Reside Benching With Beside Base Units – Planning Model

One-and-One-Half High Base Unit

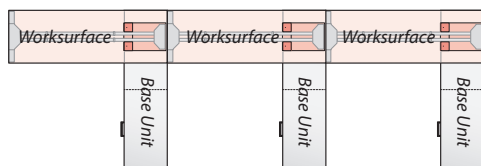

Panel Systems With Beside Base Unit – Planning Model

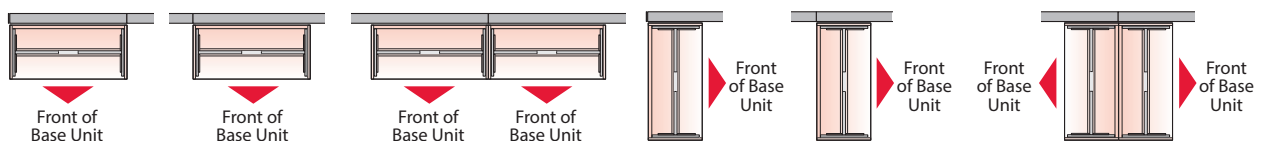

Product Application – Beside Storage

Storage Attachment Guidelines – In-Line and Back-to-Back Storage Planning Models – Ganging Bracket Kit

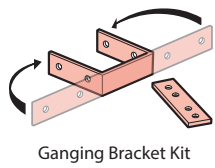

Refer to the chart below to determine which Base Units may be used with the Ganging Bracket Kit for attachment purposes. The chart applies to single, double and triple Base Units. For double or triple Base Units configured with an open, slider door or hinged door portion and a box or lateral drawer portion default to the drawer portion of the Base Unit to apply application guidelines.

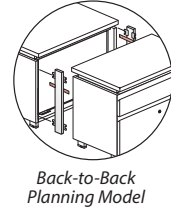
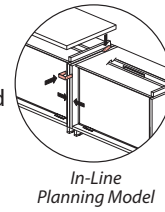

In-Line Planning Model

Two Base Units – Facing Same Direction

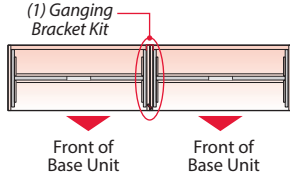

- Both Base Units may be the same or a combination of Single, Double or Triple Base Units.
- If both Base Units are type B; they may be different heights.

Base Unit Functional Type	1 High (17" High*)	1 1/2 High (23" High*)	2 High (29" High*)
A-A	NO	NO	NO
B-B	YES	YES	YES
A-B or B-A	YES	NO	NO

Two Base Units – Facing Opposite Direction

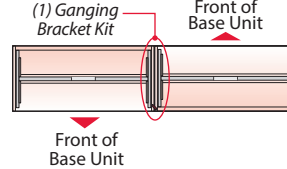

- Both Base Units may be the same or a combination of Single, Double or Triple Base Units.
- Both Base Units must be the same height.

Base Unit Functional Type	1 High (17" High*)	1 1/2 High (23" High*)	2 High (29" High*)
A-A	YES	NO	NO
B-B	YES	YES	YES
A-B or B-A	YES	NO	NO

Note Apply guidelines for longer file banks with multiples of two Base Units.

Three Base Units – Facing Same Direction

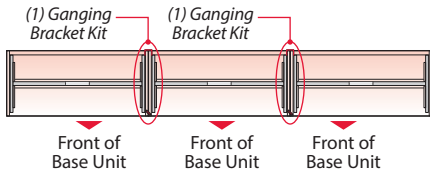

- Both Base Units may be the same or a combination of Single, Double or Triple Base Units.

Base Unit Functional Type	1 High (17" High*)	1 1/2 High (23" High*)	2 High (29" High*)
A-A-A	NO	NO	NO
B-B-B	YES	YES	YES
A-A-B, A-B-A, B-A-A	NO	NO	NO
B-B-A, B-A-B, A-B-B	YES	NO	NO

Three Base Units – Facing Opposite Direction

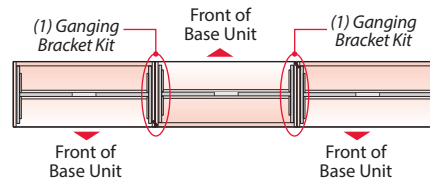

- Both Base Units may be the same or a combination of Single, Double or Triple Base Units.
- Both Base Units must be the same height.

Base Unit Functional Type	1 High (17" High*)	1 1/2 High (23" High*)	2 High (29" High*)
A-A-A	NO	NO	NO
B-B-B	YES	YES	YES
A-A-B, A-B-A, B-A-A	NO	NO	NO
B-B-A, B-A-B, A-B-B	YES	NO	NO

Note Apply guidelines for longer file banks with multiples of three Base Units.

Back-to-Back Planning Model

Back-To-Back Base Units – Facing Opposite Direction

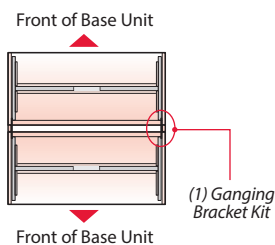

- Both Base Units may be single, double or triple height Base Units.
- If both units are Type A; they may have different drawer configurations.

Base Unit Functional Type	1 High (17" High*)	1 1/2 High (23" High*)	2 High (29" High*)
A-A	YES	YES	YES
B-B	YES	YES	YES
A-B or B-A	YES	YES	YES

* Reflects finished height; Base Unit with separately specified Storage Top

Product Application – Beside Storage

Storage Attachment Guidelines – Ganging Bracket Kit Application Guidelines

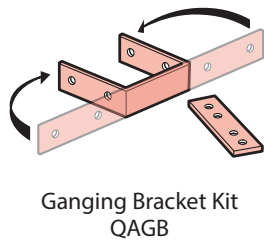

- The Beside ganging bracket kit includes two brackets. Used to gang Base Units together for increased rigidity.
- The Strap Bracket attaches adjacent side edges of vertical end panels. Strap Bracket is supplied flat and is bent in the field to U-Shape for certain applications.
- The Flat Bracket attaches adjacent top edges of vertical end panels.
- Adjacent Base Units facing the same direction require (1) Ganging Bracket Kit in a storage based planning application with an attached perpendicular Reside Worksurface.
- Adjacent Base Units facing opposite directions require (2) Ganging Bracket Kits in a storage based planning application with an attached perpendicular Reside Worksurface. (2) Two Flat Brackets attached at the top of the Base Units are required for ganging.
- Guideline applies to both type A Base Units with drawer(s) and type B Base Units without drawer(s).

Adjacent Base Units – Facing the Same Direction

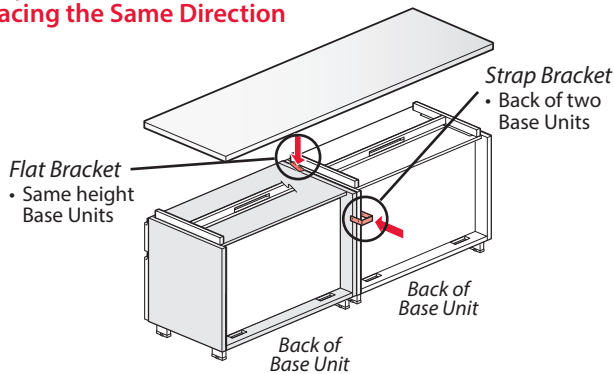

Adjacent Base Units – Facing the Opposite Direction

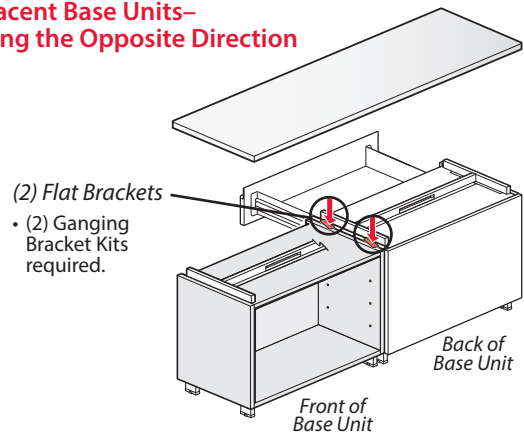

Desk-To-Storage Bracket Application –

One and One-Half High Base Units with attached perpendicular Reside worksurface

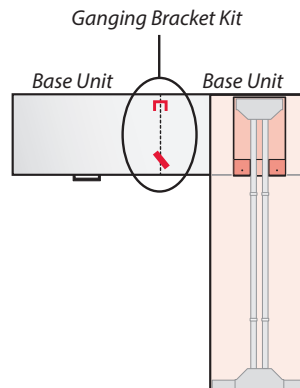
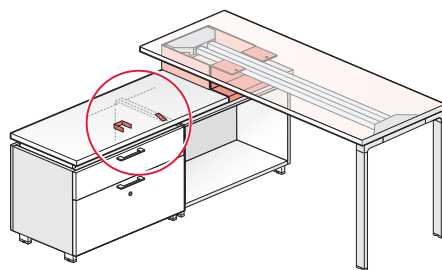

Flush Mount Plate Application –

Two High Base Units – with attached perpendicular Reside worksurface

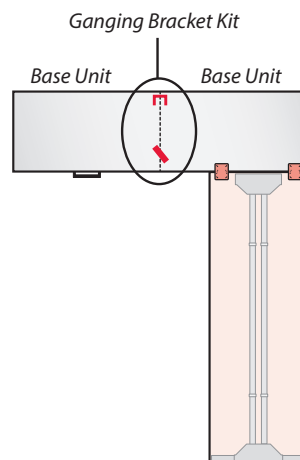
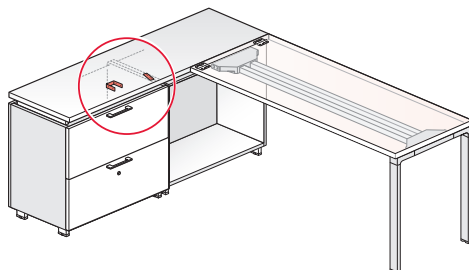

Product Application – Beside Storage

Storage Attachment Guidelines – Desk-to-Storage Bracket / Storage Attachment Bracket

Desk-to-Storage Bracket

- For use with One-and-One Half High Base Units, only
- Used to support a worksurface. Also provides support to a Beside Base Unit.

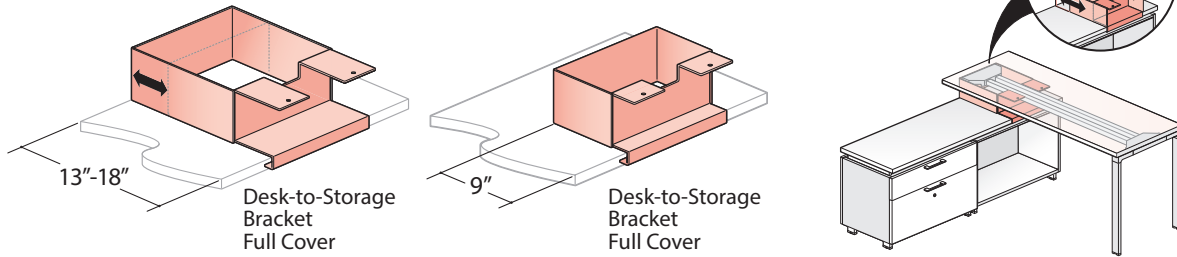

Note • All Beside Base Units with a box or lateral drawer(s) must be attached for support purposes. Base Units without drawers which are 42" wide or less must also be attached for support purposes.

- ✓ **Do Storage Based Planning Model**
 - Desk-to-Storage Bracket – provides support to Worksurfaces and One and One-Half High Base Units.

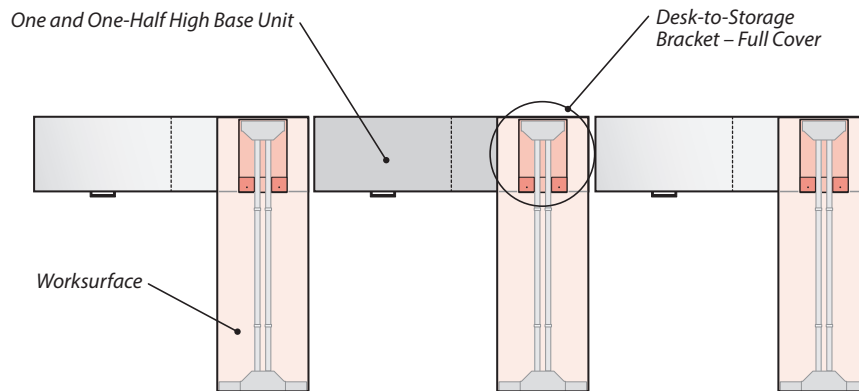

- ✓ **Do Reside Benching Planning Model**
 - Desk-to-Storage Bracket – provides support to Worksurfaces and One and One-Half High Base Unit.

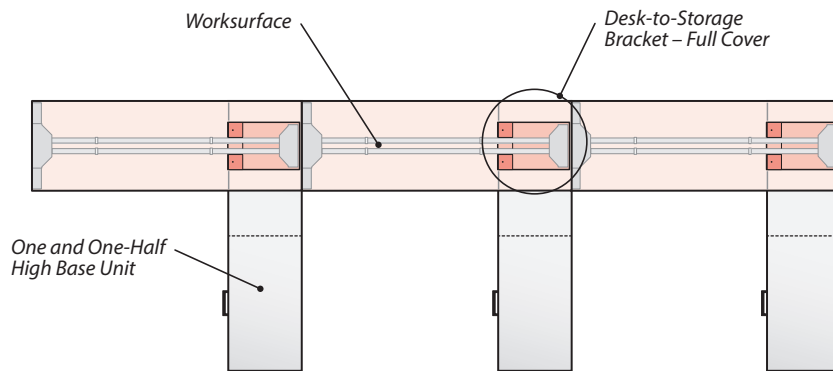

Product Application – Beside Storage

Storage Attachment Guidelines – Flush Mount Plate

Desk-to-Storage Bracket

- For use with Two-high Base Units, only
- Flush Mount Plates attached to a two-high Beside Base Unit provides floor support to one end of a worksurface and also provides support to a Beside Base Unit.
- Flush Mount Plates may be located anywhere along the front or back edge of a two-high Base Unit.
- The Flush Mount Plates attach to the underside of the Beside Storage Top and worksurface.

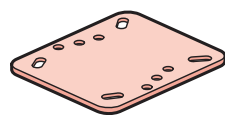

Flush Mount Plate ZUBF-PN

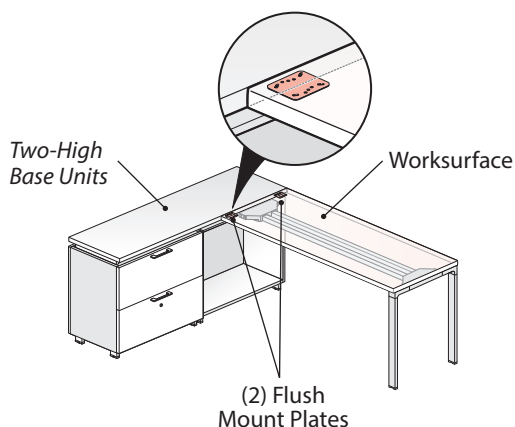

Do

Storage Based Planning Model

- Flush Mount Plate – provides support to worksurfaces and Two-High Base Units.

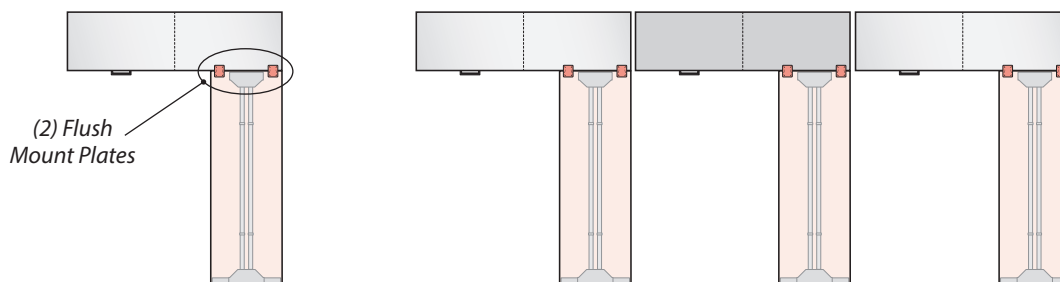

Don't

- The Base Unit spacer prohibits the Flush Mount Plate from attaching to the side of the Base Unit.

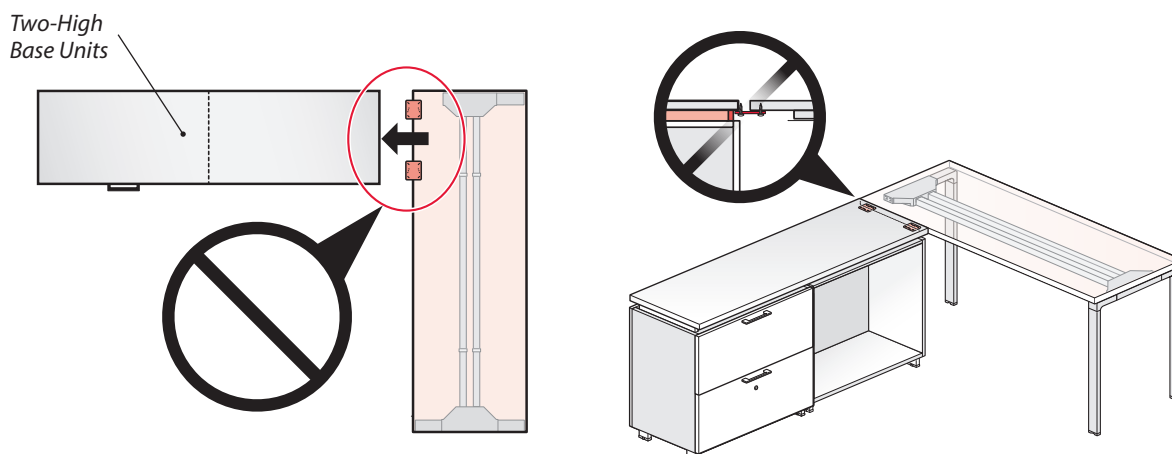

Note

- A quantity of (2) Flush Mount Plates are required to support one end of the Worksurface.

Tip

- For Flush Mount applications with the Base Units perpendicular to a Reside Worksurface, the open section of a Base Unit must be located beneath the Reside Worksurface or the back of the Base Unit if it has all drawers or doors. This is recommended for clearance reasons as the Reside structural beam interferes with opening the drawer/door in a flush mount application.

Product Application – Beside Storage

Storage Attachment Guidelines – Panel Systems and Base Units

Beside Base Unit integrated with panel system.

Storage-to-Panel Bracket

- Attaches One-High, One and One-Half High and Two-High Base Units to systems panel slots.
- Specify a systems specific bracket for Compose, PREMISE or UniGroup applications.
- Storage-To-Panel Bracket used with a Beside Base Unit provides various degrees of panel support. Refer to the appropriate panel system Specification Guide for application guidelines.
- Additional support variables include which panel system and if the Storage-to-Panel Bracket is being used with a separately specified Adaptable Anti-Dislodgement Clip Kit. Refer to the appropriate panel system Specification Guide for application guidelines.

Storage To Panel Bracket – Parallel Planning Model – One or Two Base Units

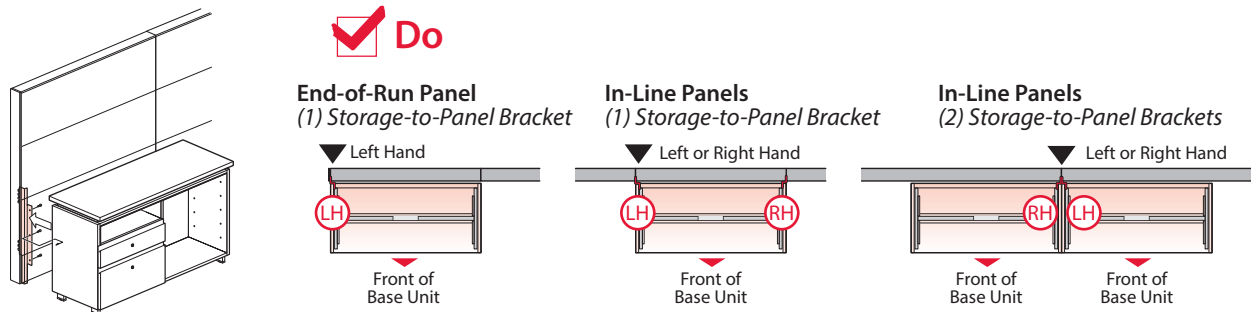

Parallel to Panel
Storage-to-Panel-Bracket – Left Hand

Storage To Panel Bracket – Perpendicular Planning Model – One or Two Base Units

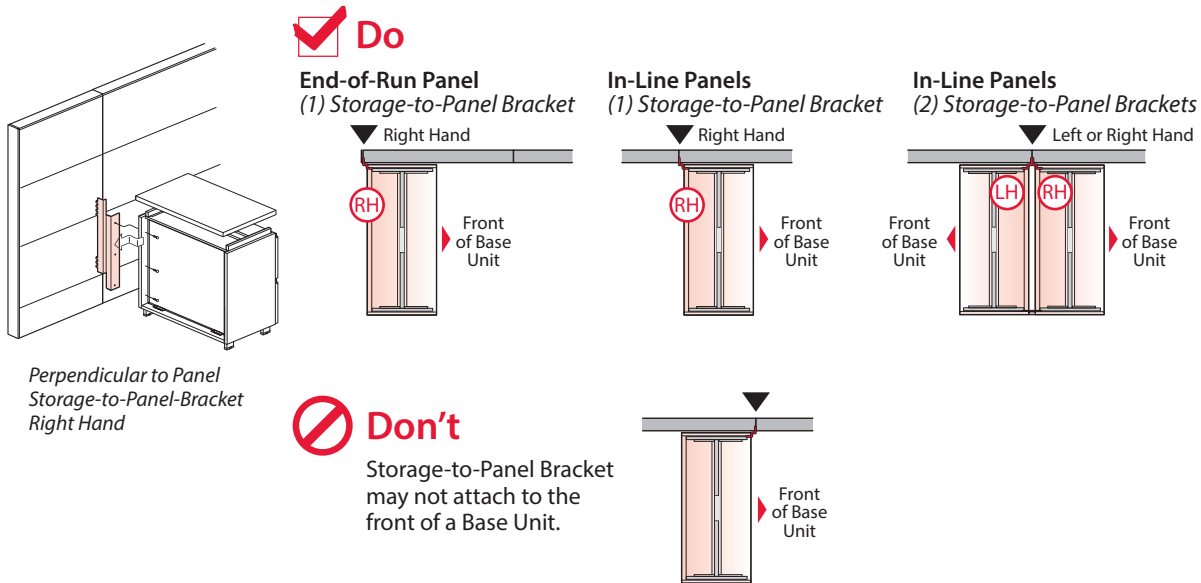

Perpendicular to Panel
Storage-to-Panel-Bracket
Right Hand

Adaptable Anti-Dislodgement Clip Kit with a Storage-To-Panel Bracket attaching a Two High Beside Base Unit parallel or perpendicular to a Panel Run.

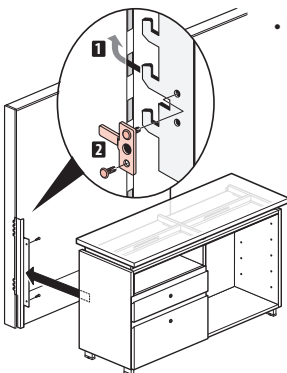

- Two High Beside Base Unit, Storage-to-Panel Brackets and the Adaptable Anti-Dislodgement Clip Kit are separately specified. Used together they provide anti-dislodgement support. Refer to the appropriate panel system Specification Guide for application guidelines.

Product Application – Beside Storage

Storage Based Planning With Attached Perpendicular Worksurface – Application Guidelines

- A perpendicular Reside Worksurfaces requires a separately specified support bracket(s).
- Type A Base Unit with drawer(s) must be supported by a perpendicular Reside worksurface attached to a spanning Storage Top.
- 72 combined inches of Type A Base Unit with drawer(s) is the maximum allowed per perpendicular worksurface. The combined inches is the overall width of multiple in-line Base Units with drawers.

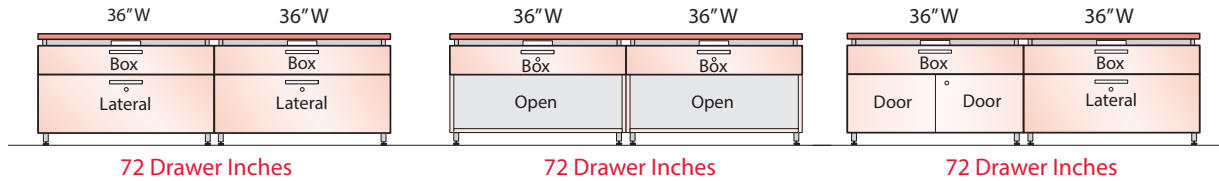

Perpendicular Worksurface requires separately specified Support Bracket(s).

One-and-One-Half High Base Units With Perpendicular Reside Worksurface Support Bracket – Desk-to-Storage Bracket (Full or Half Cover)

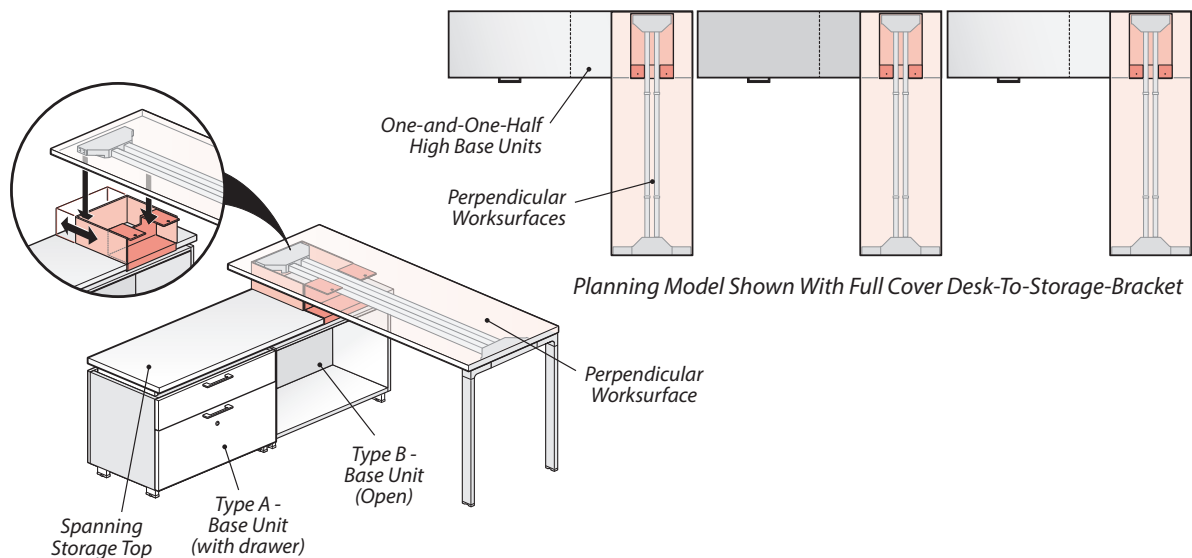

Two High Base Unit With Perpendicular Reside Worksurface Support Bracket – (2) Two Flush Mount Plates

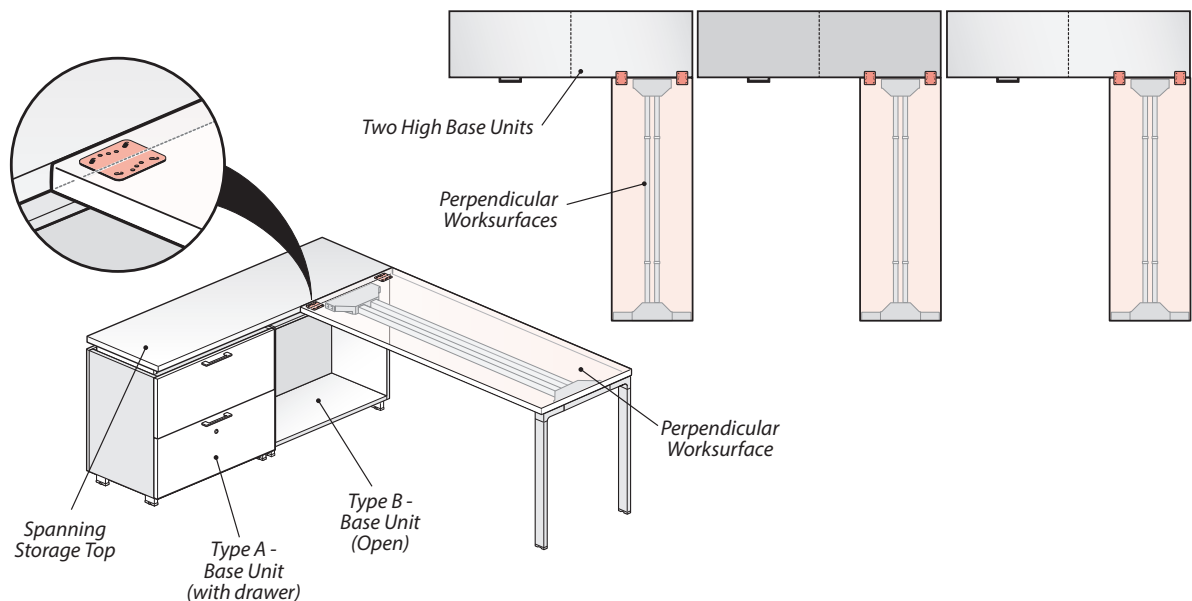

Product Application – Beside Storage

Storage Based Planning With Attached Perpendicular Worksurface – Desk-To-Storage Bracket Application Guidelines

- The Desk-to-Storage Bracket attached to a one-and-one-half high Beside Base Unit provides floor support to one end of a Reside worksurface.
- Available in several depths to correspond with the Reside worksurface depths.
- The Desk-to-Storage Bracket has two cover options; half or full cover to accommodate multiple applications.
- Catalog number includes the Desk-to-Storage Bracket with the user specified cover option.
- Desk-to-Storage Bracket must be installed on the centerline of the Reside Worksurface to enclose the Central Block and Support Beams.

Desk-to-Storage Bracket – Half Cover

- Half cover provides a 9" overlap between the Reside Worksurface and the Beside Base Unit.

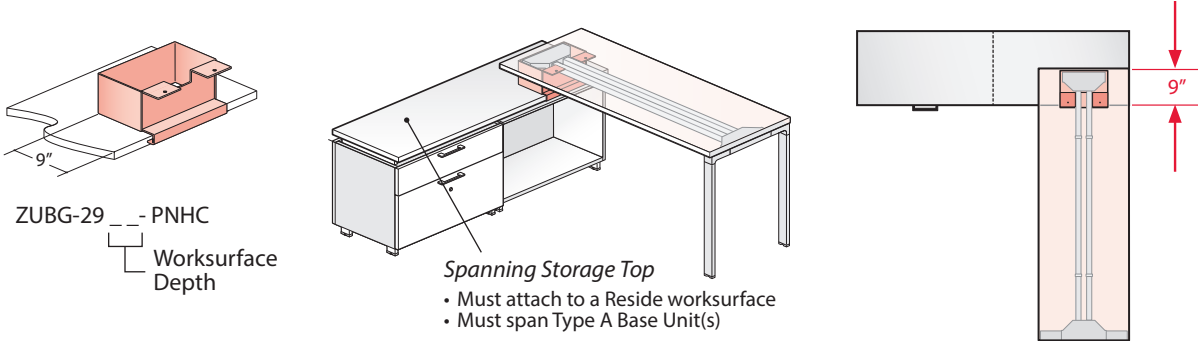

Tip • The Beside Storage Attachment Bracket is not for use in this application; it does not provide proper Worksurface support.

Note • If a utility tray is utilized in the above application it must be 6" less than the width of the Reside Worksurface.
• Do not specify a Hatch cutout above the Desk-to-Storage Bracket; it will not be accessible.

Desk-to-Storage Bracket – Full Cover

- Full cover provides a 13" or 18" overlap between the Reside Worksurface and the Beside Base Unit.

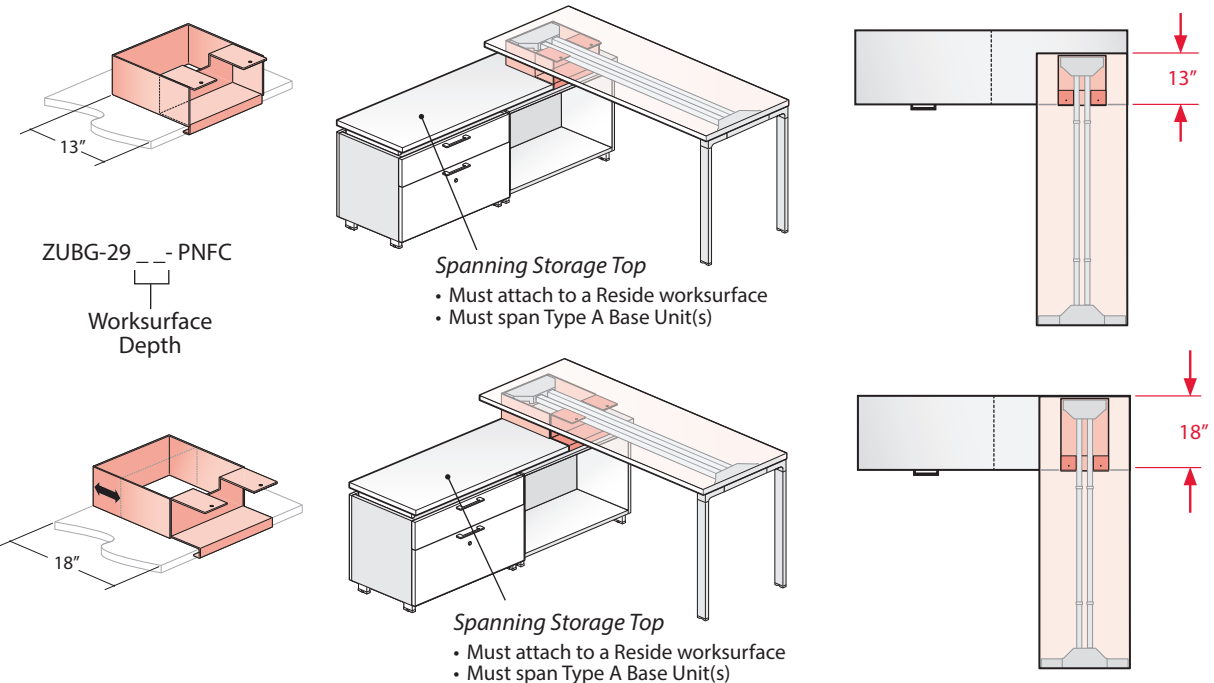

Tip • The Beside Storage Attachment Bracket is not for use in this application; it does not provide proper worksurface support.
• The Wedge worksurface is not for use with the Desk-to-Storage Bracket with Full Cover.

Note • If a Utility Tray is utilized in the above application length must be reduced to accommodate attachment to storage.
• Do not specify a Hatch cutout above the Desk-to-Storage Bracket; it will not be accessible.

Product Application – Beside Storage

Storage Based Planning With Attached Perpendicular Worksurface – Desk-To-Storage Bracket Application Guidelines

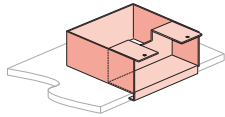

Desk-to-Storage Bracket

- The Desk-to-Storage Bracket with half or full cover may be located anywhere along the front or back edge of a One-and-One-Half High Base Unit.
- The Desk-to-Storage bracket attaches to the edge of the Beside Storage Top and to the underside of the Reside worksurface.

Desk-to-Storage Bracket – Attachment to **FRONT** of Beside Base Unit

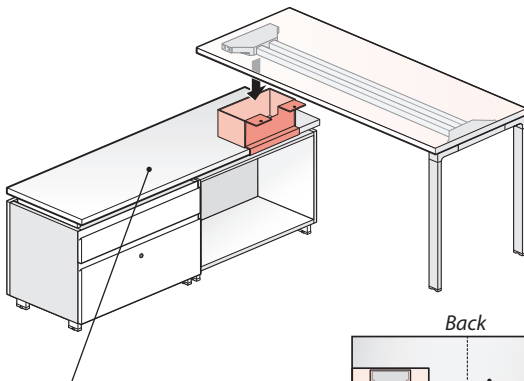

Spanning Storage Top

- Must attach to a Reside worksurface
- Must span Type A Base Unit

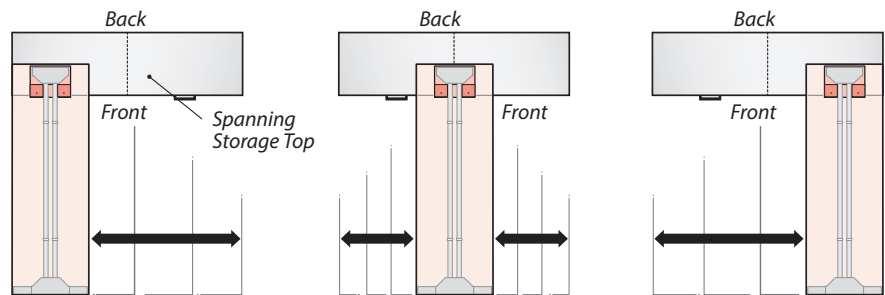

Desk-to-Storage Bracket – Attachment to **BACK** of Beside Base Unit

- Bracket does not interfere with the finished back.

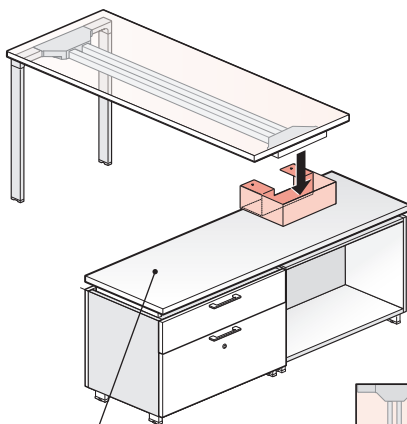

Spanning Storage Top

- Must attach to a Reside worksurface
- Must span Type A Base Unit

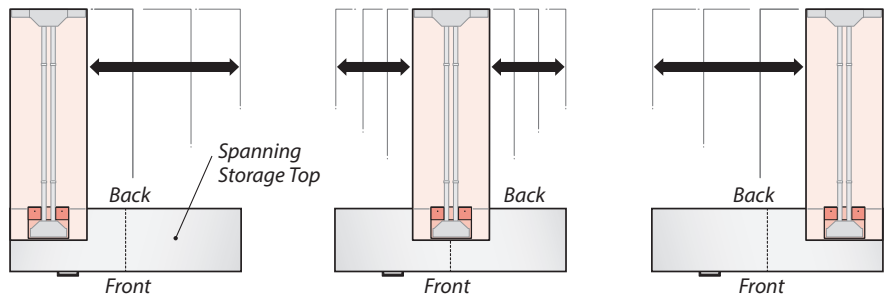

Notes

- Locating the Desk-to-Storage Bracket above a drawer in a One and One-Half High application limits drawer accessibility.
- Do not attach perpendicular worksurfaces to the side(s) of a Base Unit.

Product Application – Beside Storage

Storage Based Planning With Attached Perpendicular Worksurface – Desk-to-Storage Bracket Application Guidelines

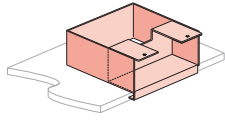

Desk-to-Storage Bracket

- The Desk-to-Storage Bracket attached to one and one-half high Beside Base Unit provides floor support to one end of a perpendicular Reside Worksurface.
- Desk-to-Storage Brackets may be located anywhere along the front or back edge of a one and one-half high Base Unit.
- The Desk-to-Storage Bracket attaches to the underside of the Beside Storage Top and Reside Worksurface.



Do

- Desk-to-Storage Bracket must be installed on the centerline of the Reside Worksurface to enclose the Central Block and Support Beams.

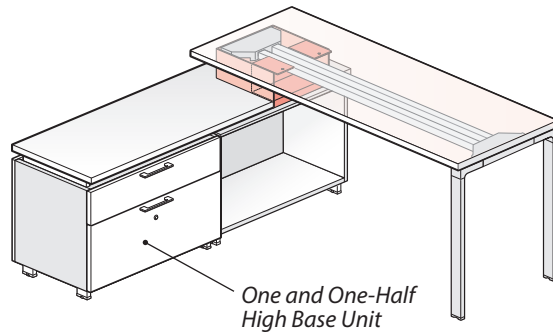

One and One-Half High Base Unit

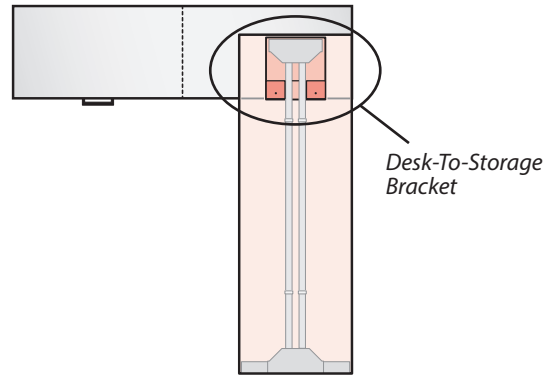

- Type A Base Units adjacent to Reside Worksurfaces must not have a drawer in the top location of the Base Unit to avoid interference with opening and using the drawer.



Don't

- The Base Unit Spacer prohibits the Desk-to-Storage Bracket from attaching to the side of the Base Unit.
- This configuration prevents nesting Worksurface Central Block and Support Beams in the Desk-To-Storage Bracket.

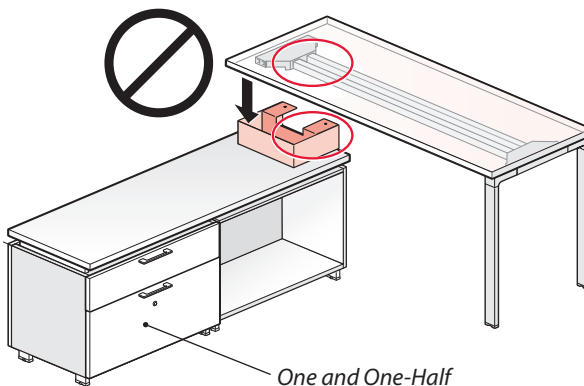

One and One-Half High Base Unit

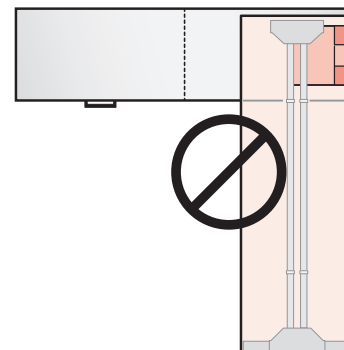

Product Application – Beside Storage

Storage Based Planning With Attached Perpendicular Worksurface – Flush-Mount Plate Application Guidelines

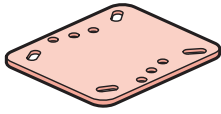

Flush Mount Plate
ZUBF-PN

- Flush mount plates attached to a two-high Beside Base Unit provides floor support to one end of a Reside worksurface.
- Flush Mount Plates may be located anywhere along the front or back edge of a two-high Base Unit.
- The Flush Mount Plates attach to the underside of the Beside Storage Top and Reside worksurface.

 **Do** Flush Mount Plates– Reside Worksurface attachment to the **FRONT** of Beside Base Unit

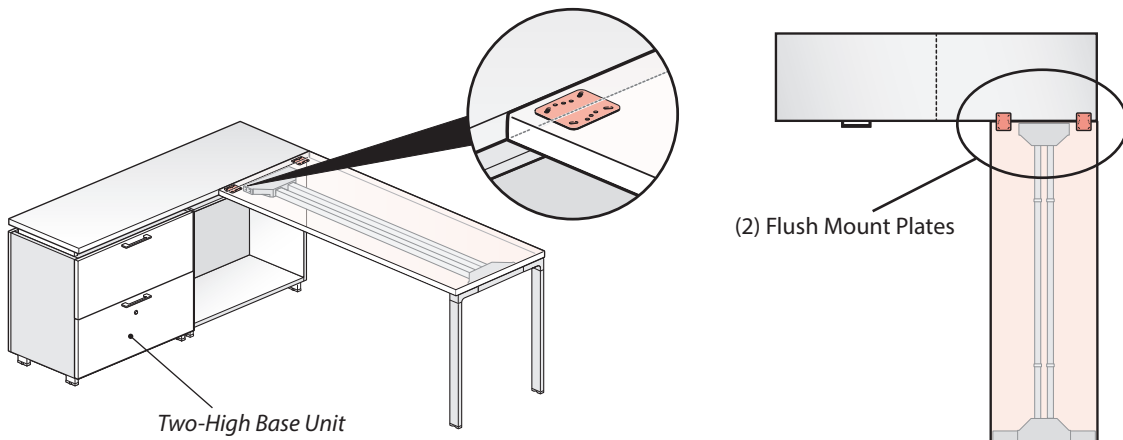

Note • A quantity of (2) Flush Mount plates are required to support one end of the worksurface.

Tip • For Flush Mount applications with the Base Unit perpendicular to a Reside Worksurface, the open section of a Base Unit must be located beneath the Reside Worksurface or the back of the Base Unit if it has all drawers or doors. This is recommended for clearance reasons as the Reside structural beam interferes with opening the drawer/door in a flush mount application.

 **Don't** Flush Mount Plates– Reside Worksurface attachment to the **SIDE** of Beside Base Unit

- The Base unit spacer prohibits the flush mount plate from attaching to the side of the Base Unit.

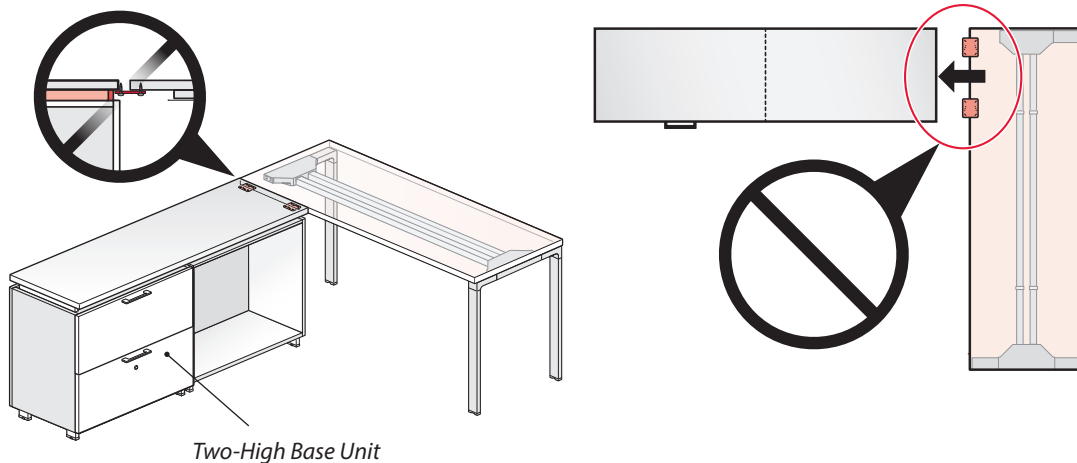

Product Application – Beside Storage

Storage Based Planning With Attached Perpendicular Worksurface – Mixed Type A and Type B Base Unit Applications

- Type A Base Units with drawer(s) must be supported by a perpendicular Reside Worksurface attached to a spanning Storage Top.
- The perpendicular Worksurface attached to a spanning Storage Top is required to support the drawer Base Units.
- The Storage Top must span the open Base Units to provide the drawer Base Units the required support.

One Spanning Storage Top – Application 1

(1) Spanning Storage Top

- Must attach to a Reside Worksurface
- Must span Type A Base Units

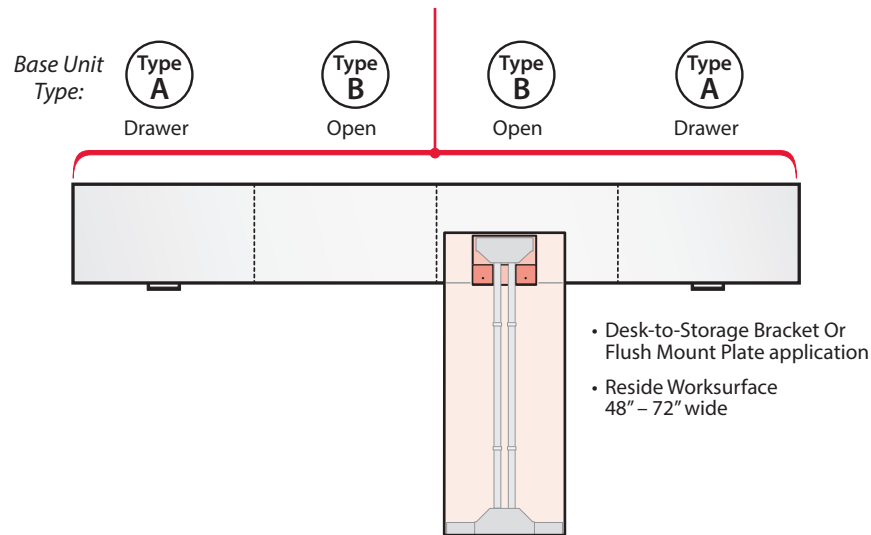

Two Spanning Storage Tops – Application 2

(2) Spanning Storage Tops

- Must attach to a Reside Worksurface
- Must span Type A Base Units

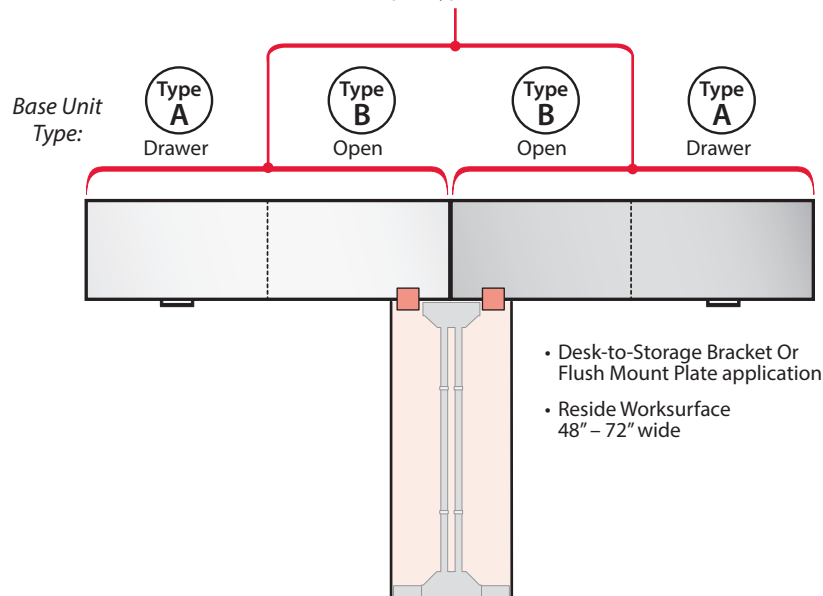

- For Desk-To-Storage Bracket applications using One and One-Half High Base Units, Type A Base Units adjacent to Reside Worksurfaces must not have a drawer in the top location of the Base Unit to avoid interference with opening and using the drawer.
- For Flush Mount applications with Two-High Base Units, the open section of a Base Unit must be located beneath the Reside Worksurface or the back of the Base Unit if it has all drawers or doors. This is recommended for clearance reasons as the Reside structural beam interferes with opening the drawer/door in a flush mount application.



- Both of these applications require (3) Ganging Bracket Kits for proper support and load.
- 120" is the widest Storage Top available for a Beside Base Unit application without additional support.
- Worksurfaces may be located anywhere along front or back edge of the Storage Top.

Product Application – Beside Storage

Storage Based Planning With Attached Perpendicular Worksurface – Mixed Type A and Type B Base Unit Applications

- Type A Base Unit with drawer(s) must be supported by a Reside perpendicular worksurface attached to a spanning Storage Top. (Continued)

Two Spanning Storage Tops – Application 3

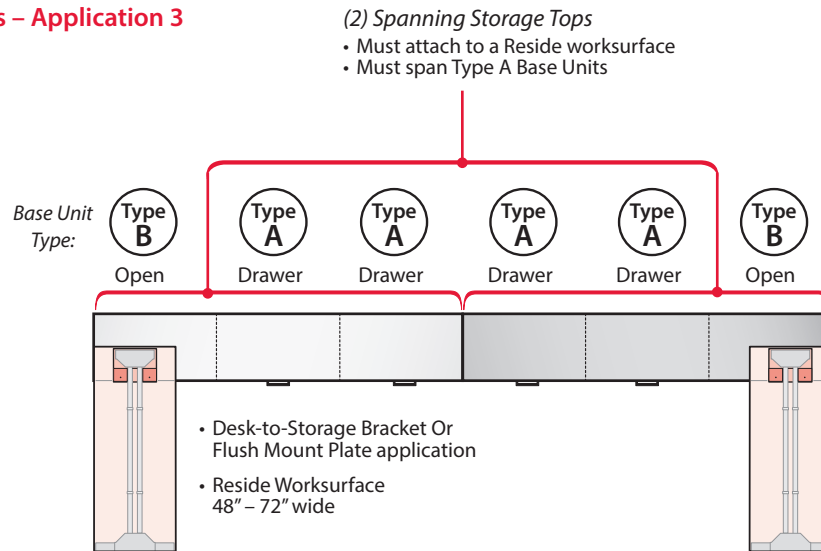

Three Spanning Storage Tops – Application 4

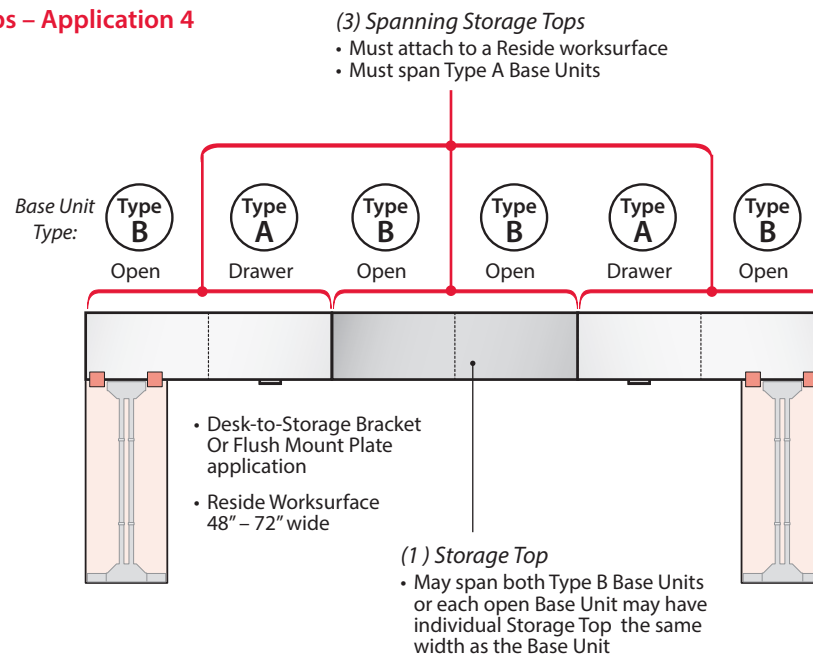

- Tip**
- Type A Base Units adjacent to Reside Worksurfaces must not have a drawer or hinged doors in the top location of the Base Unit to avoid interference with opening and using the drawers or hinged doors.

- Note**
- Both of these applications require (5) Ganging Bracket Kits for proper support and load.
 - 120" is the widest Storage Top available for Beside Base Unit applications.
 - Worksurfaces may be located anywhere along the front edge of the Storage Top.

Product Application – Beside Storage

Storage Based Planning With Attached Perpendicular Worksurface – Application Guidelines For Type A Base Units

- 72 combined drawer inches of Type A Base Unit with drawer(s) is the maximum allowed per perpendicular worksurface.
- The combined drawer inches is the overall width of multiple in-line Base Units with drawers.

Calculating Inches Of Drawer Units

EXAMPLES:

36" Wide Single Base Units

- Each of the Base Units shown below have 36 drawer inches.

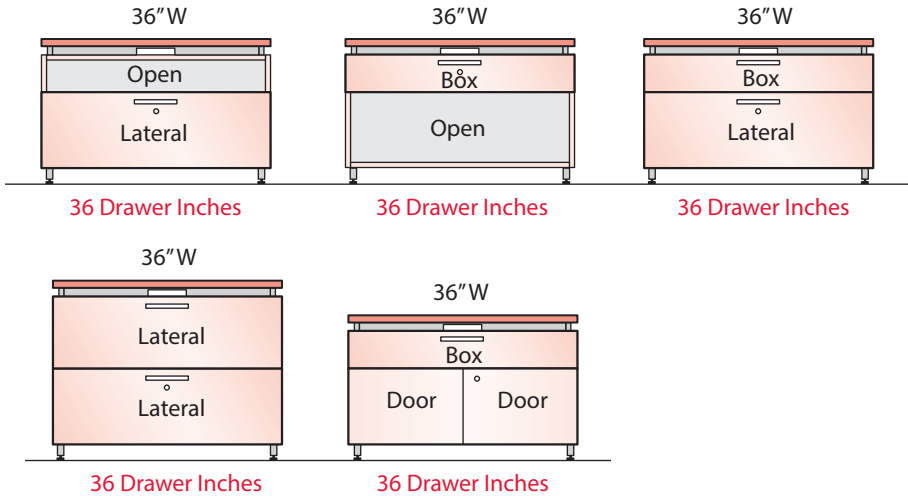

- All One and One-Half High and Two High Base Units with drawers must be attached to a Reside perpendicular worksurface.
- Each of the above examples requires a perpendicular Reside Worksurface attached to a Storage Top for proper support.

Two 36" Wide Single Base Units

- Each of the Base Unit applications shown below have 72 drawer inches:

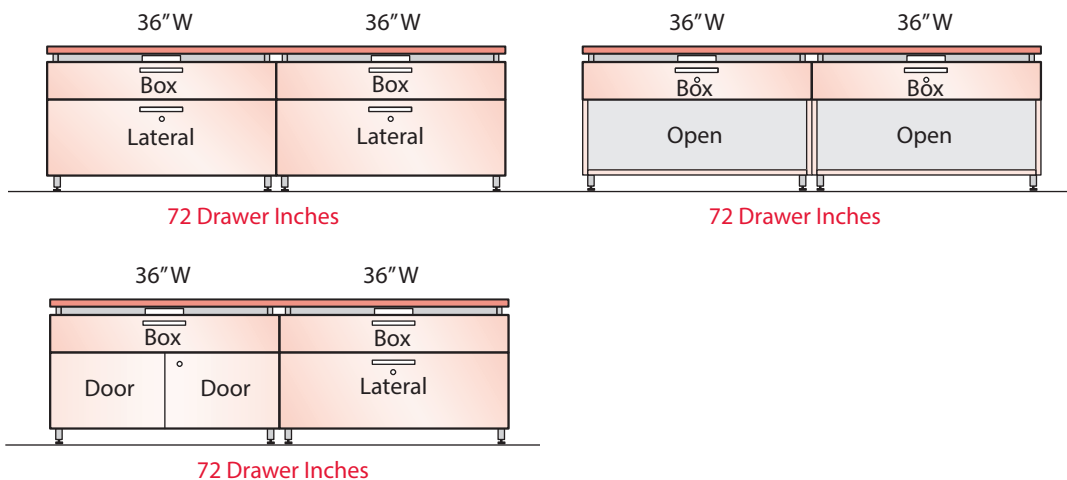

- 72" is the maximum combined drawer inches allowed per perpendicular worksurface.
- Each of the above examples require a perpendicular Reside worksurface attached to a spanning Storage Top for proper support.
- A Ganging Bracket Kit is also required for additional support between Base Units.

Product Application – Beside Storage

Storage Based Planning With Attached Perpendicular Worksurface – Application Guidelines For Mixed Type A and Type B Base Units

• Each application option shown below has 72 combined drawer inches.

Mix Of Base Units / Type A And Type B Base Unit Applications

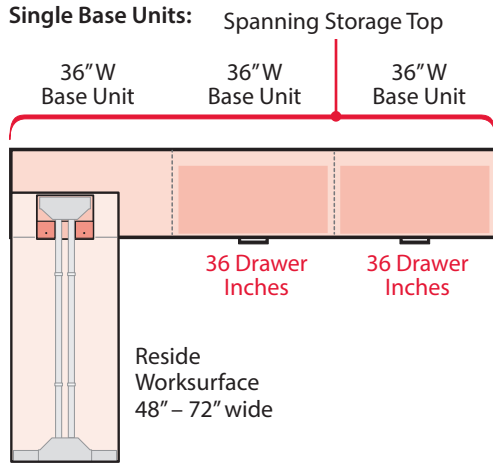

One And One-Half High Base Units With Drawers:
 • (2) 36" W Base Units with lateral drawer

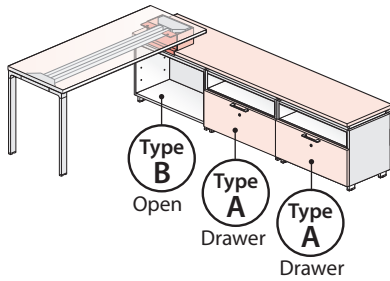

One And One-Half High Base Units With Drawers:
 • (2) 36" W Base Units with box drawer

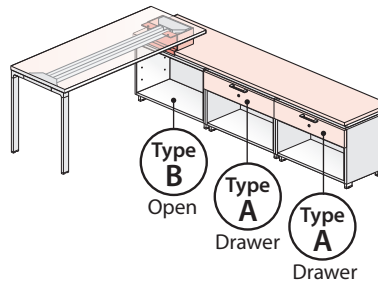

Two High Base Units With Drawers:
 • (2) 36" W Base Units with lateral drawers

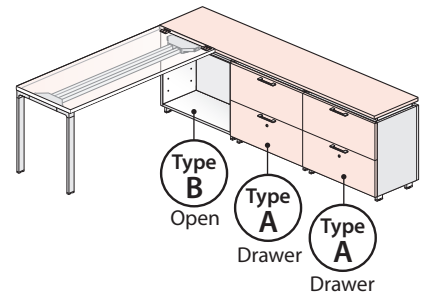

Single and Triple Base Units:

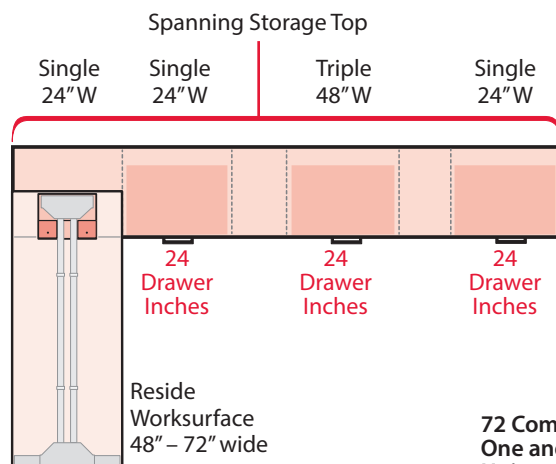

48" W Triple Combination Base Unit is standard with 24" Wide drawer

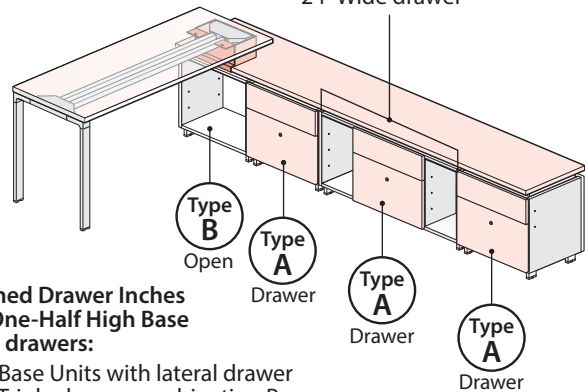

72 Combined Drawer Inches One and One-Half High Base Units with drawers:

- (2) 24" W Base Units with lateral drawer
- (1) 48" W Triple drawer combination Base Unit with 24" W lateral drawer

Note

• Same guidelines apply to Reside worksurfaces attached to two-high Base Units with Flush Mount Plates.

Product Application – Beside Storage

Storage Based Planning With Attached Perpendicular Worksurface – Worksurface Interference with Base Unit Drawers / Hinged Doors

In a two-high storage spine application with attached Worksurfaces, plan around potential drawer or door interference.

- Base Units with hinged doors or storage drawers in the top position do not have the required clear access to open due to the structural beams beneath the Reside Worksurface. To avoid interference do not locate a storage drawer or hinged door directly beneath the flush mount attached Reside Worksurface.

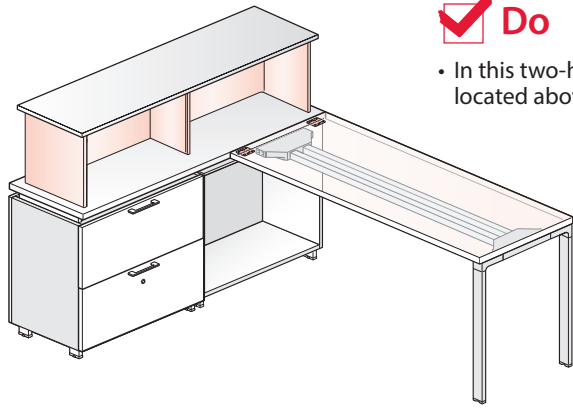

✓ Do

- In this two-high storage based planning application the Reside Worksurface is located above an open storage unit allowing for a functional storage application.

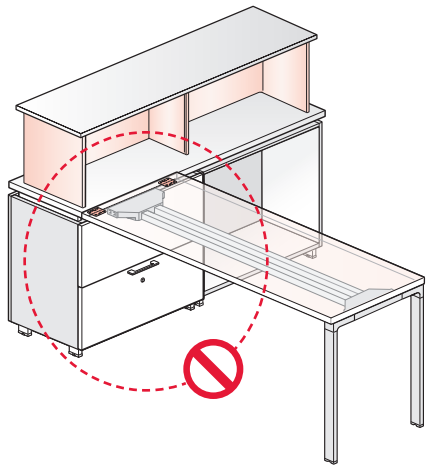
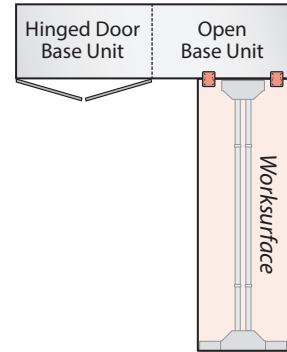
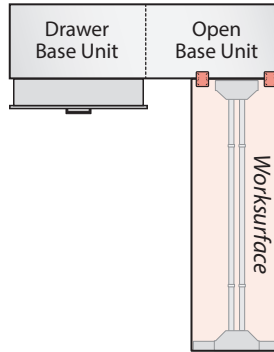

✗ Don't

- The Reside Worksurface is located above a Beside Base Unit with a file drawer in the top position.
- The worksurface interferes with the functionality of the drawer and prevents it from opening.

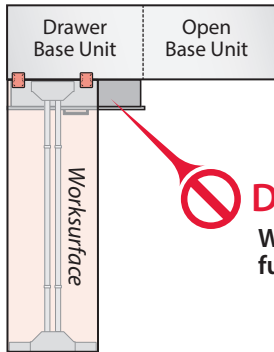

✗ Don't
Worksurface interferes with functionality of the drawer.

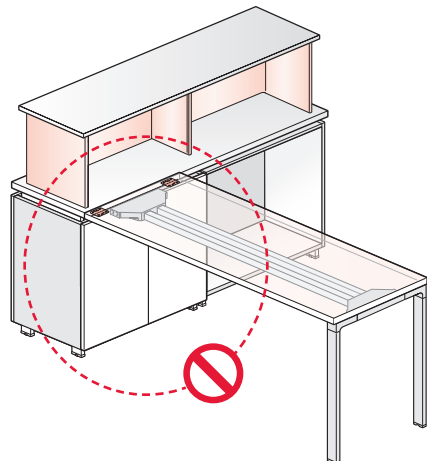

✗ Don't

- The Worksurface is located directly above a Base Unit with hinged doors.
- The worksurface interferes with the functionality of the hinged doors and prevents them from opening.

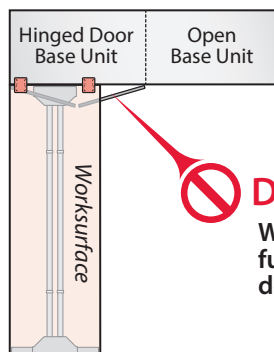

✗ Don't
Worksurface interferes with functionality of the hinged doors.

Product Application – Beside Storage

Storage Based Planning With Attached Perpendicular Worksurface – Screen Interference with Base Unit Drawers

In storage spine applications with attached Worksurfaces with Screens, plan around potential drawer interference with the Screen.

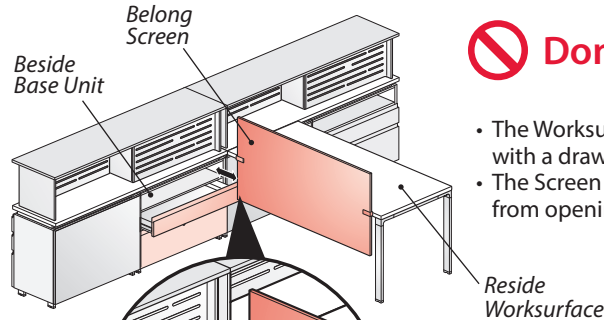

Don't

- The Worksurface and the Screen are mounted adjacent to a Beside Base Unit with a drawer.
- The Screen interferes with the functionality of the drawer and prevents it from opening.

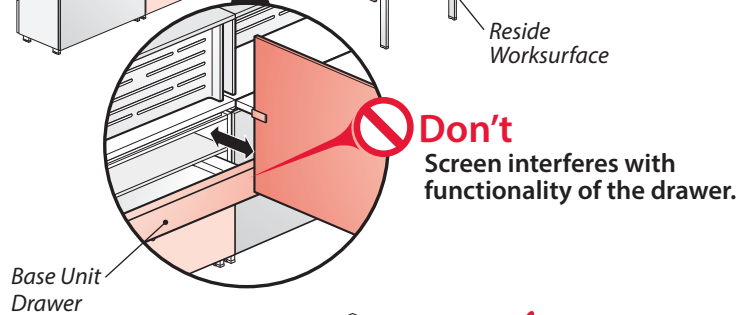

Don't
Screen interferes with functionality of the drawer.

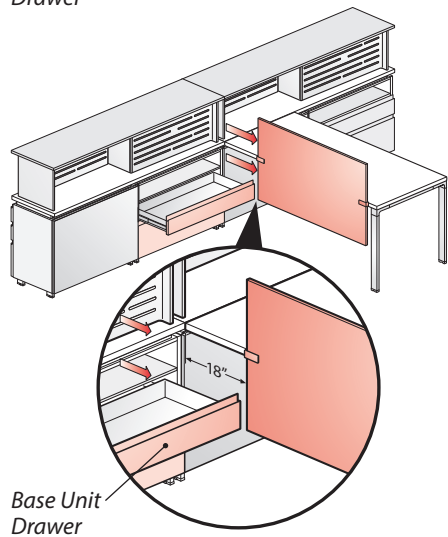

Do

- In storage spine applications with attached Worksurfaces with Screens, specify the Screen 18" shorter than the Worksurface width. Position the Screen on the Worksurface allowing the drawer to fully open.

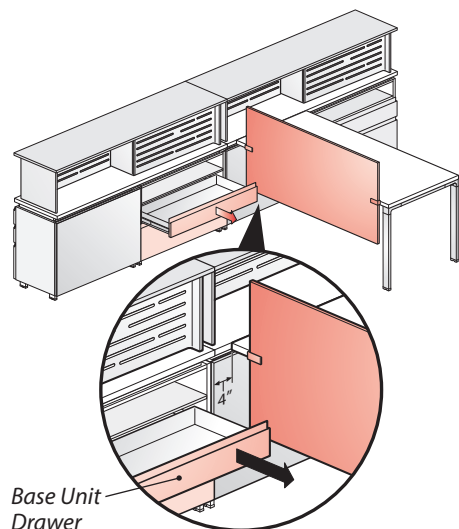

Do

- In storage spine applications with attached Worksurfaces with Screens mount the Worksurface a minimum of 4" from the drawer to allow adequate clearance with the Screen for the drawer to open.

Product Application – Beside Storage

Application Overview – Storage Based Planning with Single Sided Rectilinear Benching

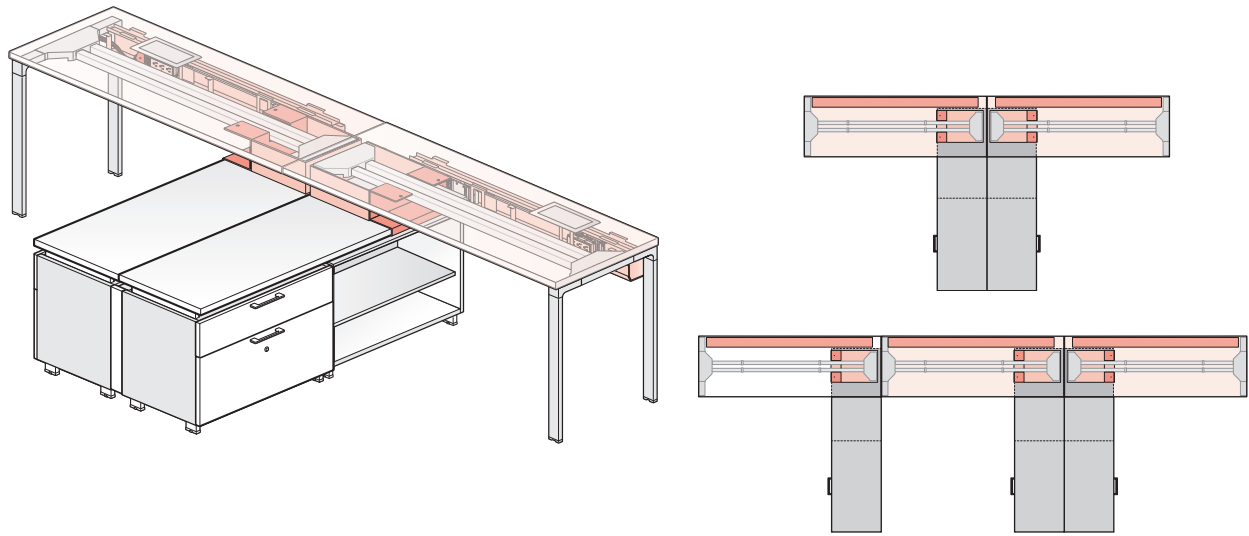

Simple Specification:

- Rectilinear Worksurface(s) specified with hatch cutouts.
- Infeed used to access building power (uses two power connectors or any receptacle location on Power Distribution Assembly).
- Powered Utility Tray specified to match worksurface width(s) and Single Utility Tray Cover.
- Jumper(s) to continue power from one Powered Utility Tray to the next Receptacles specified for power access.

Desking/Benching – Worksurfaces, Legs and Brackets

Worksurface:

- Rectangular Worksurface

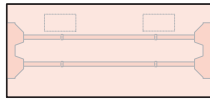

Worksurface Alternatives:

- Articulated Transition Worksurface
- Wedge Worksurface
- Bent Worksurface

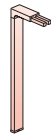

Legs:

- Straight Leg – Fixed

Leg Alternatives:

- Angled Leg
- Adjustable Hoop Leg – Single Desk

Bracket:

- Desk-to-Storage Bracket – Full Cover

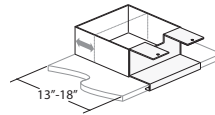

Storage – Base Units, Shelves, Brackets, Stanchions and Hutch Shelf

Base Units:

- Open – Single Width – 1.5-High
- Drawer Combination – Single Width – 1.5-High

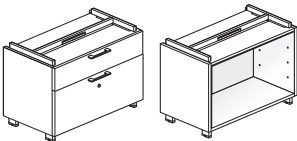

Base Unit Alternatives:

- Open Storage with Drawer
- Hinged Door
- Hinged Door and Open Storage
- Hinged Door and Drawer Combination
- Single Sliding Door

Shelf:

- Base Unit Accessory Shelf

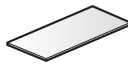

Storage Top:

- Base Unit Storage Top



Brackets:

- Ganging Bracket Kit

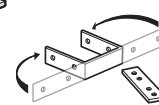

Filler Panel:

- Base Unit Filler Panel



Electrical – Electrical Components and Accessories

Power In:

- Infeed Harness

Power In Alternatives:

- Infeed Harness
- Internal Power Base™ AI Base Feed
- Base Feed Module – Architectural Concealed – Hardwire Connection
- Top Feed

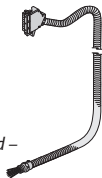

Power Through:

- Utility Tray Single Powered

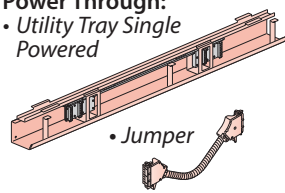

Power Out:

- Triplex Receptacles



Wire Management:

- Base Feed Cover

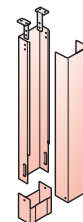

- Utility Tray End Cover – Single

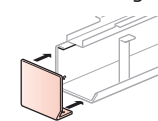

- Hatch – No Tray

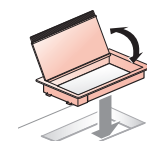

Product Application – Beside Storage

Application Overview – Storage Based Planning with Double Sided Rectilinear Benching

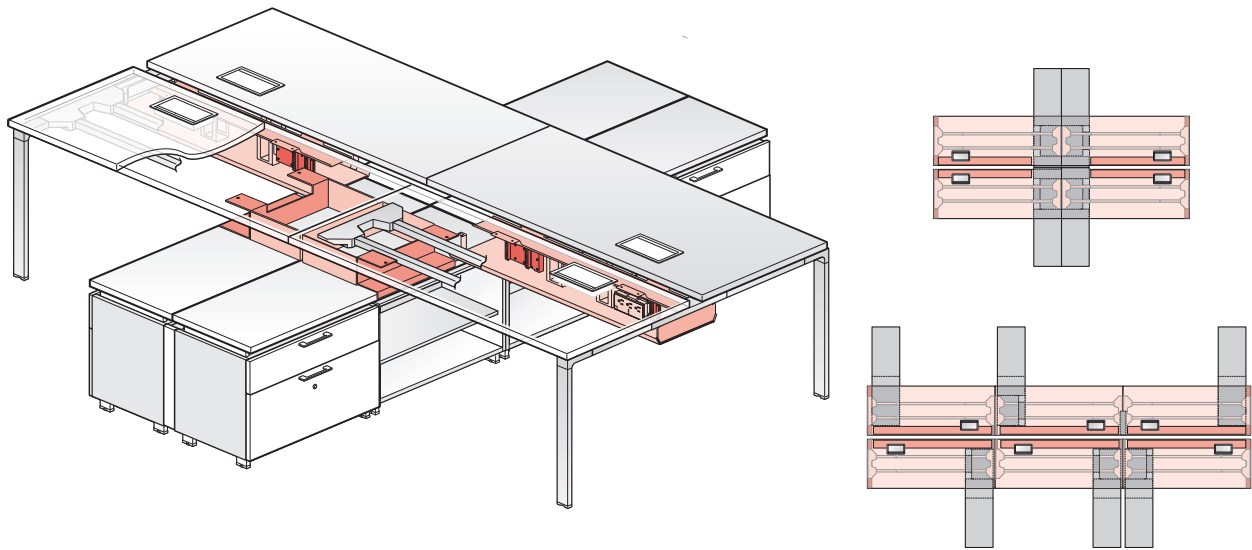

Simple Specification:

- Rectilinear Worksurface(s) specified with hatch cutouts.
- Infeed used to access building power (uses two power connectors or any receptacle location on Power Distribution Assembly).
- Powered Utility Tray specified to match worksurface width(s) and Single Utility Tray Cover.
- Jumper(s) to continue power from one Powered Utility Tray to the next Receptacles specified for power access.

Desking/Benching – Worksurfaces, Legs and Brackets

Worksurface:

- Rectangular Worksurface

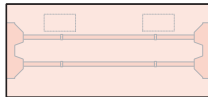

Worksurface Alternatives:

- Articulated Transition Worksurface
- Wedge Worksurface
- Bent Worksurface

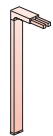

Legs:

- Straight Leg – Fixed

Leg Alternatives:

- Angled Leg
- Adjustable Hoop Leg – Double Benching

Brackets:

- Desk-to-Storage Bracket – Full Cover

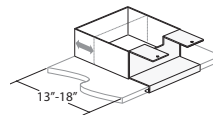

- Shared Block Connector

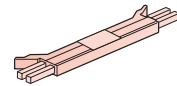

Storage – Base Units, Shelves, Brackets, Stanchions and Hutch Shelf

Base Units:

- Open – Single Width – 1.5-High
- Drawer Combination – Single Width – 1.5-High

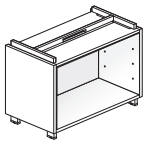
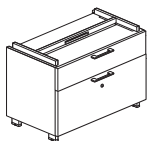

Base Unit Alternatives:

- Open Storage with Drawer
- Hinged Door
- Hinged Door and Open Storage
- Hinged Door and Drawer Combination
- Single Sliding Door

Shelf:

- Base Unit
- Accessory Shelf

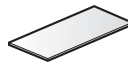

Storage Top:

- Base Unit
- Storage Top

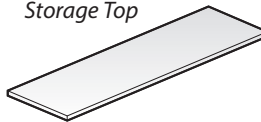

Brackets:

- Ganging Bracket Kit

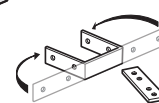

Filler Panel:

- Base Unit
- Filler Panel



Electrical – Electrical Components and Accessories

Power In:

- Infeed Harness

Power In Alternatives:

- Infeed Harness
- Internal Power Base™
- AI Base Feed
- Base Feed Module –
- Architectural Concealed – Hardwire Connection
- Top Feed



Power Through:

- Utility Tray Single Powered

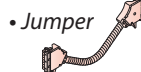
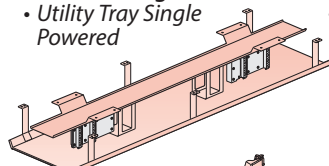

Power Out:

- Triplex Receptacles



Wire Management:

- Base Feed Cover

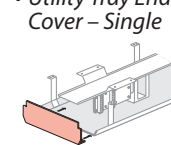
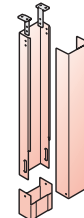

- Hatch – No Tray

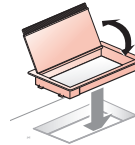

Product Application – Beside Storage

Application Overview – Storage Based Desking Cluster With Single Depth Storage Spine

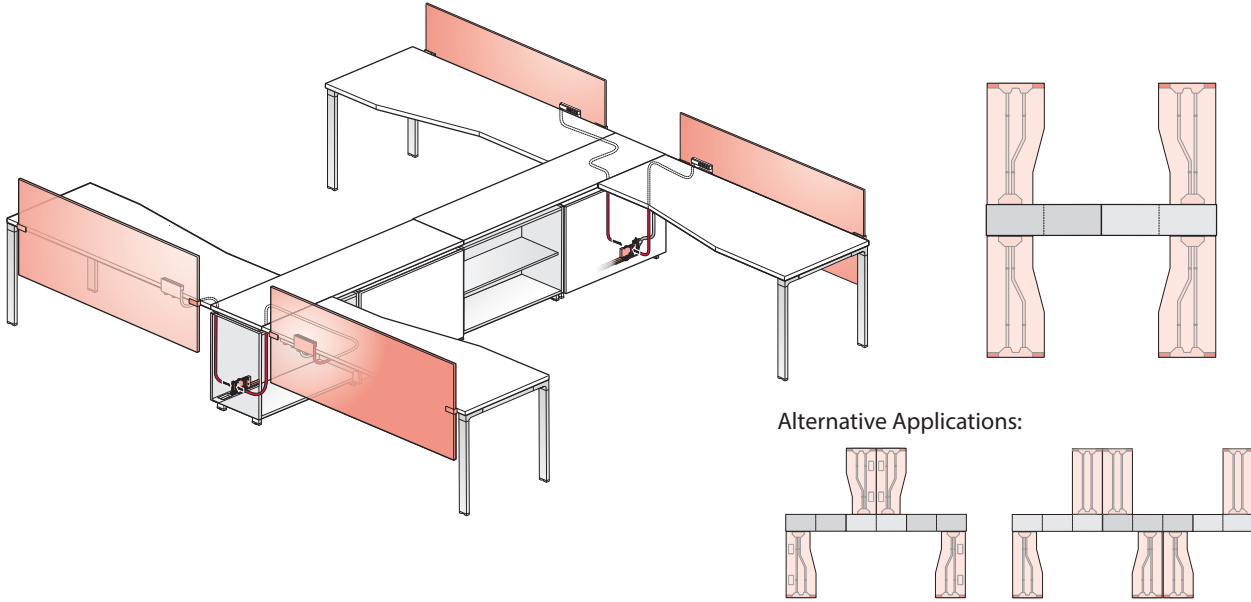

Simple Specification:

- Infeed to access building power location (uses two power connectors or any receptacle location on PDA).
- Power Distribution Assembly (PDA) specified to match Base Unit width(s).
- Jumper(s) to continue power from one powered Base Unit to the next.
- Power Tap -Horizontal and Power Tap Bracket – Fixed specified for power access.

Desking – Worksurfaces, Legs and Brackets

Worksurfaces:

- Articulated Transition Worksurface

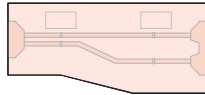

- Worksurface Alternatives:**
- Rectangular Worksurface
 - Wedge Worksurface
 - Bent Worksurface

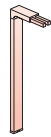

Legs:

- Straight Leg – Fixed

- Leg Alternatives:**
- Angled Leg
 - Adjustable Hoop Leg – Single Desk

Bracket:

- Flush Mount Plate

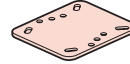

Storage – Base Units, Shelves, Brackets, Stanchions and Hutch Shelf

Base Units:

- Open – Single Width – Two-High

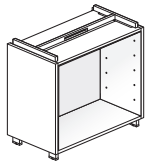

Base Unit Alternatives:

- Open Storage with Drawer
- Drawer Combinations
- Hinged Door
- Hinged Door and Open Storage
- Hinged Door and Drawer Combination
- Single Sliding Door

Shelf:

- Base Unit Accessory Shelf



Storage Top:

- Base Unit Storage Top



Back:

- Finished Back



Brackets:

- Ganging Bracket Kit

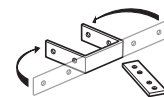

Electrical – Electrical Components and Accessories

Power In:

- Infeed Harness

Power In Alternatives:

- Infeed Harness
- Internal Power Base™ AI Base Feed
- Base Feed Module – Architectural Concealed – Hardwire Connection
- Top Feed

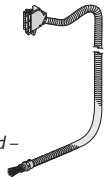

Power Through:

- PDA (Power Distribution Assembly)
- Jumper

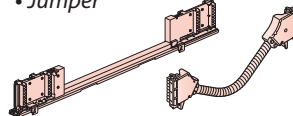

Power Out:

- Power Tap Horizontal
- Power Tap Bracket Fixed

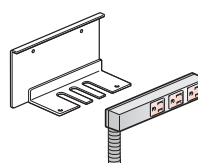

Power Out Alternatives:

- Power Tap Vertical
- Power Tap Bracket with Grommet Vertical
- Power Tap Bracket Adjustable
- Power Tap Bracket with Grommet Horizontal

Screens, Work Tools and Accessories:

Screens:

- Screen – Back

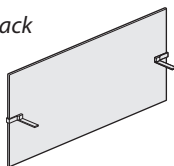

Product Application – Beside Storage

Application Overview – Storage Based Desking Cluster With Double Depth Storage Spine

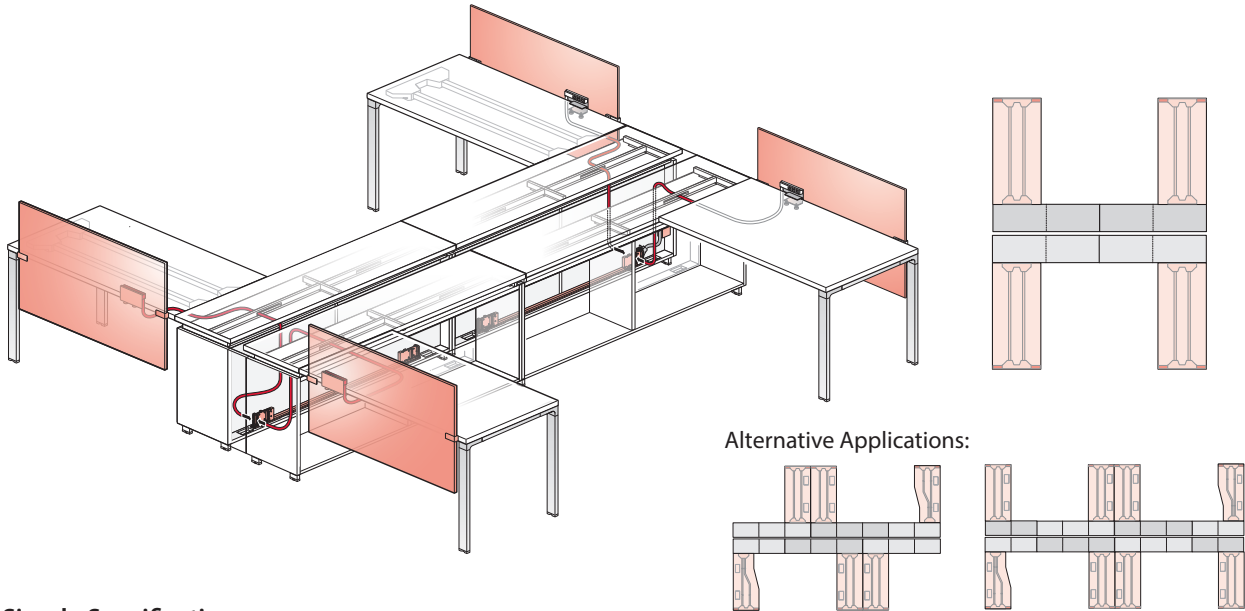

Simple Specification:

- Infeed to access building power location (uses two power connectors or any receptacle location on PDA).
- Power Distribution Assembly (PDA) specified to match Base Unit width(s).
- Jumper(s) to continue power from one powered Base Unit to the next.
- Power Tap – Horizontal and Power Tap Bracket with Grommet – Horizontal specified for power access.

Desking – Worksurfaces, Legs and Brackets

Worksurfaces:

- Rectangular Worksurface



- Worksurface Alternatives:**
- Articulated Transition Worksurface
 - Wedge Worksurface
 - Bent Worksurface

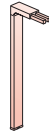

Legs:

- Straight Leg – Fixed
- Leg Alternatives:**
- Angled Leg
 - Adjustable Hoop Leg – Single Desk

Bracket:

- Flush Mount Plate



Storage – Base Units, Shelves, Brackets, Stanchions and Hutch Shelf

Base Units:

- Open – Single Width – Two-High

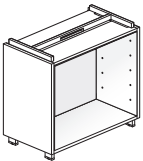

- Base Unit Alternatives:**
- Open Storage with Drawer
 - Drawer Combinations
 - Hinged Door
 - Hinged Door and Open Storage
 - Hinged Door and Drawer Combination
 - Single Sliding Door

Shelf:

- Base Unit Accessory Shelf



Storage Top:

- Base Unit Storage Top

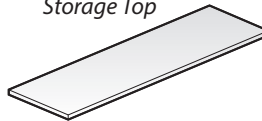

Brackets:

- Ganging Bracket Kit

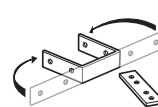

Filler Panel:

- Filler Panel – Two-High



Electrical – Electrical Components and Accessories

Power In:

- Infeed Harness
- Power In Alternatives:**
- Infeed Harness
 - Internal Power Base™ AI Base Feed
 - Base Feed Module – Architectural Concealed – Hardwire Connection
 - Top Feed



Power Through:

- PDA (Power Distribution Assembly)
- Jumper

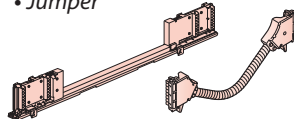

Power Out:

- Power Tap Horizontal
- Power Tap Bracket with Grommet Horizontal

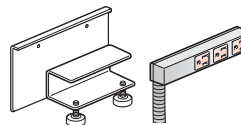

- Power Out Alternatives:**
- Power Tap Vertical
 - Power Tap Bracket with Grommet Vertical
 - Power Tap Bracket Fixed
 - Power Tap Bracket Adjustable

Screens, Work Tools and Accessories:

Screens:

- Screen – Back

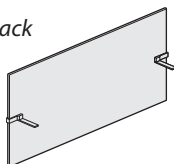

Product Application – Beside Storage

Stanchion Kits – Vertical Planning Models

One-High Hutch Application

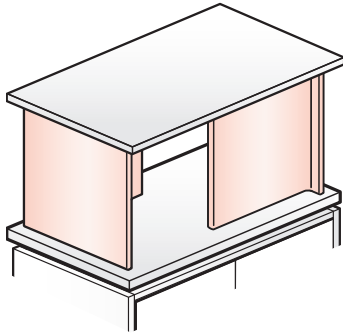

Two-High Hutch Application

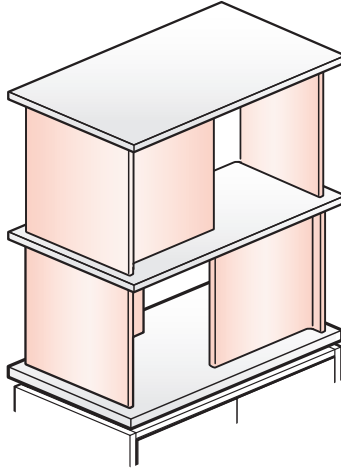

Three-High Hutch Application

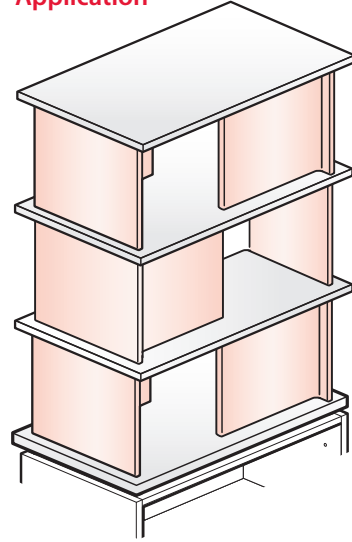

One-High Stanchion Mounted Overhead Storage Unit application

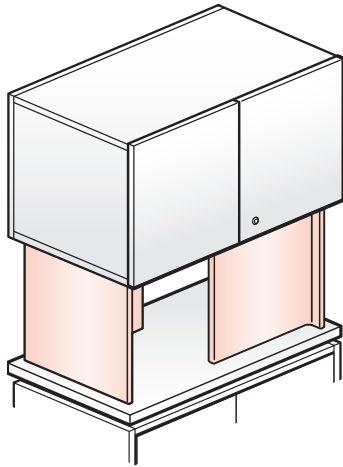

Two-High Stanchion Mounted Overhead Storage Unit application

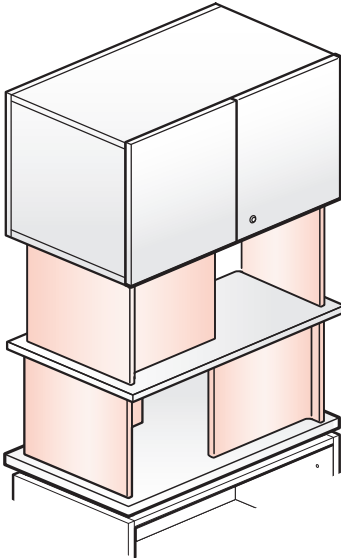

Note The storage components shown above are available in multiple configurations and sizes; refer to the Beside Price List for options.

Tip • Hutch applications and/or Stanchion Mounted Overhead Storage Unit applications with Beside Base Unit may not exceed 58" high.
 • A Beside Overhead Storage Unit may be center mounted above a Compose, PREMISE or UniGroup panel; may not exceed 66" high.

Product Application – Beside Storage

Stanchion Kits – Hutch Applications

- A Beside Storage Top is a separately specified component which is required above a Beside Storage Unit.
- A separately specified Hutch Shelf encloses the top of the Stanchion Kit creating a Hutch Application.
- A maximum of three Stanchion Kits are allowed in a Hutch application; two-high and three-high Stanchion Kit applications may not exceed 58" high including Base Unit.

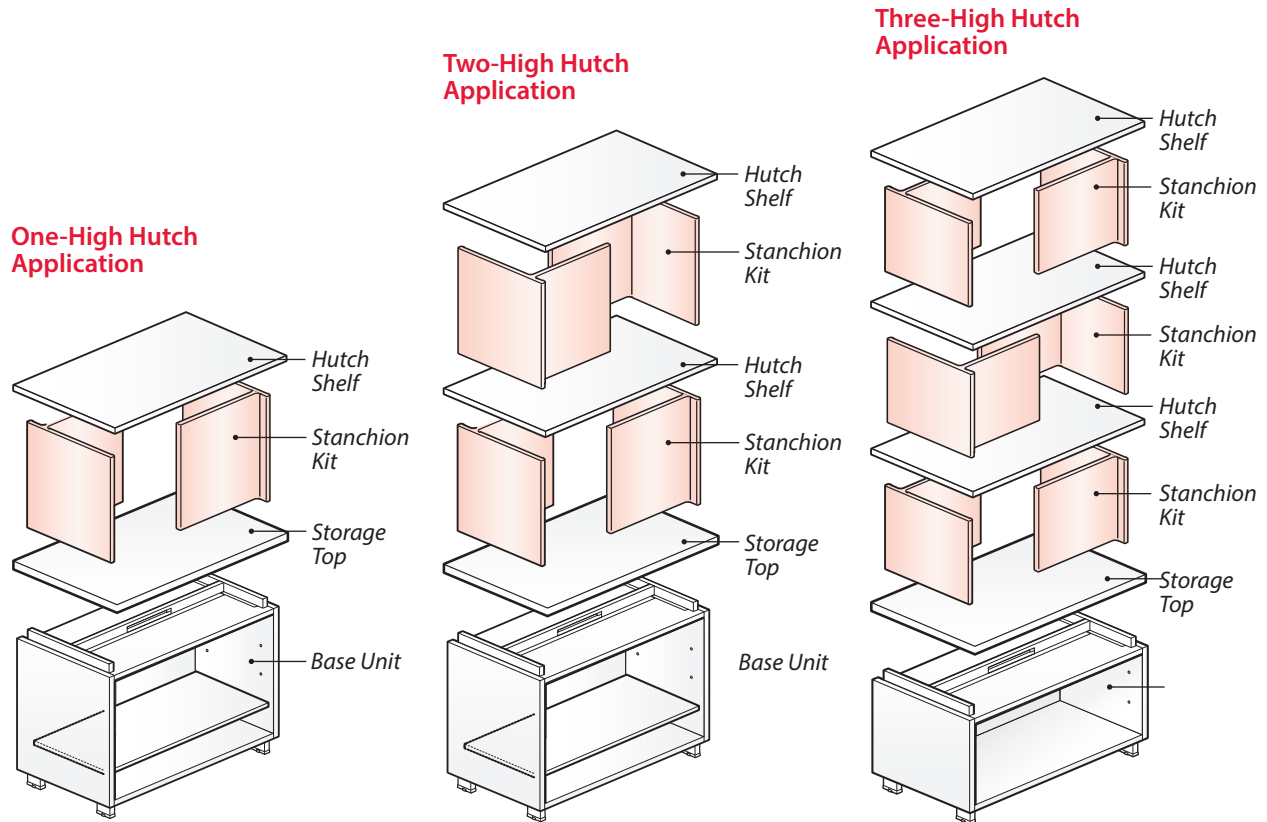

✓ Do

- Hutch applications consist of separately specified components: Base Unit, Storage Top, Stanchion Kit and Hutch Shelf.
- Hutch applications must be under 58" in height.
- Stanchion Kits may be located one above another with a Hutch Shelf between Stanchion Kits and at the top of the upmost Stanchion Kit.
- Hutch Shelf width must match the Stanchion Kit width.
- A Stanchion Kit may span multiple Base Units if the Base Units have a single spanning Storage Top.

⊘ Don't

- Stanchions are not for use on top of a Reside Table or Desking Worksurface or Return.
- Hutch is not for use on an panel mounted Adaptable Worksurface.
- Hutch Shelf may not span side-by-side Stanchion Kits.
- Hutch applications may not exceed 58" in height.

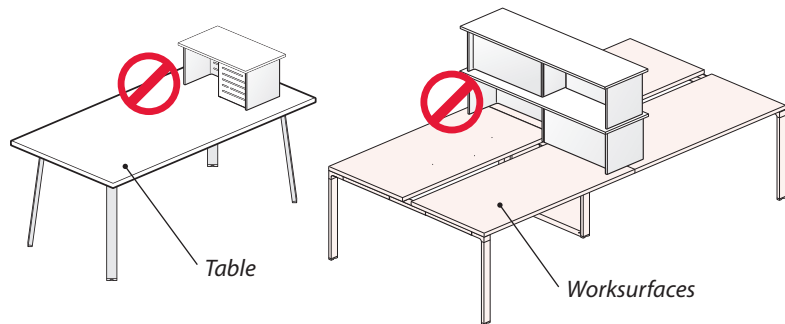

Tip

- Hutch applications and/or Stanchion Mounted Overhead Storage Unit applications with Beside Base Unit may not exceed 58" high.
- A Beside Overhead Storage Unit may be center mounted above a Compose, PREMISE or UniGroup panel; may not exceed 66" high.

Product Application – Beside Storage

Stanchion Kits – Stanchion Mounted Overhead Storage Unit Applications

- A Beside Storage Top is a separately specified component which is required above a Beside Base Unit in a Stanchion Kit application.
- A Beside Overhead Storage Unit may be located above a Stanchion Kit creating a Stanchion Mounted Overhead Storage Unit application.
- **A maximum of two Stanchion Kits are allowed in a Stanchion Mounted Overhead Storage Unit application; may not exceed 58" high including Base Unit.**
- In a two-high Stanchion Mounted Overhead Storage Unit application a separately specified Hutch Shelf is required between Stanchion Kits.
- A Hutch Shelf not required between the Stanchion Kit and the Beside Overhead Storage Unit.

One-High Stanchion Mounted Overhead Storage Unit Application

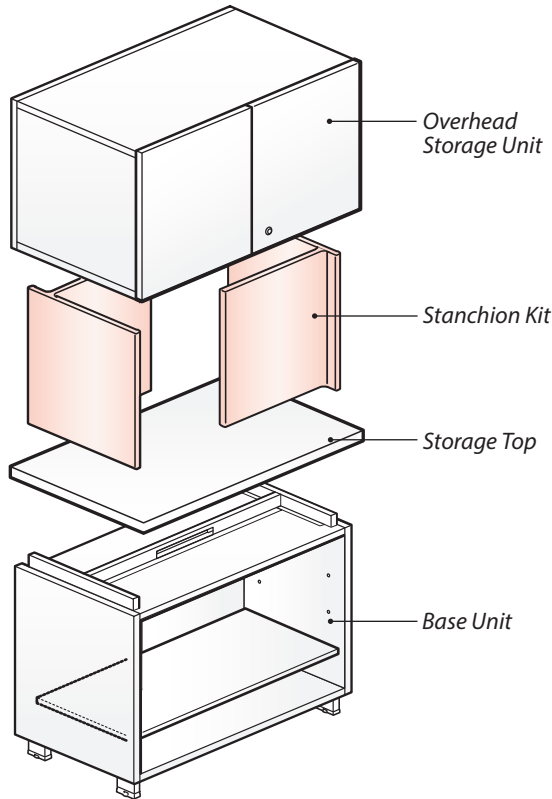

Two-High Stanchion Mounted Overhead Storage Unit Application

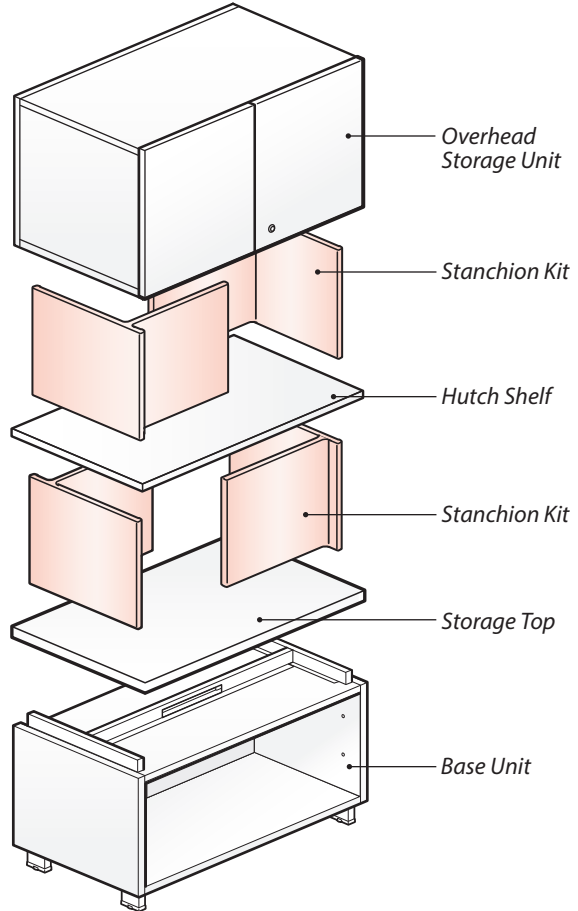

✓ Do

- Separately specify Stanchion Kit (hardware included), Storage Top and Base Unit.
- Separately specify Adaptable Task Light and/or LED Light for use with Stanchion mounted OSU.
- Overhead Storage Units (OSU) may be attached above separately specified Stanchion Kits and at the top of the upmost Stanchion Kit.

⊘ Don't

- Hutch applications not to exceed 58" in height
- Beside OSU cannot be freestanding
- Beside OSU cannot be mounted to a Reside table, worksurface or Return Worksurface.

Note

- The storage components shown above are available in multiple configurations and sizes; refer to the Beside Price List for options.
- Hutch Shelf is not required between the Stanchion Kit and the Overhead Storage Unit.

Tip

- Hutch applications and/or Stanchion Mounted Overhead Storage Unit applications with Beside Base Unit may not exceed 58" high.
- A Beside Overhead Storage Unit may be center mounted above a Compose PREMISE or UniGroup panel; may not exceed 66" high.

Product Application – Beside Storage

Six Easy Steps – Designing A Hutch Application

- Step 1 Beside Base Unit –** Beside Base Unit is used to support a Stanchion Kit.
Note: Stanchion Kits are not for use on desking Worksurfaces/Return Worksurfaces, panel mounted Adaptable Worksurfaces, or Desk Shells.
- Step 2 Beside Storage Top –** (required; separately specify)
A separately specified Beside Storage Top is a required component above a Beside Base Unit.
- Step 3 Beside Stanchion Kit –** (located in a one-high position)
A Beside Stanchion Kit may be used above a Beside Base Unit with Storage Top for additional vertical storage. Available in multiple configurations and sizes.
- Step 4 Beside Hutch Shelf –** (required; separately specify)
A separately specified 3/4" thick Hutch Shelf encloses the top of the Stanchion Kit creating a Hutch Application. When stacking Stanchion Kits above one another a Hutch Shelf is required between Stanchion Kits.
Note: Beside Hutch Shelf must be the same nominal width as the Stanchion Kit.
- Step 5 Beside Stanchion Kit –** (located in two-high position)
A Beside Stanchion Kit may be used above one another for additional vertical storage.
- Step 6 Beside Hutch Shelf –** (required; separately specify)
A Hutch Shelf is required at the top of a Stanchion Kit to stabilize the vertical panels.
Note: Beside Hutch Shelf must be the same nominal width as the Stanchion Kit.

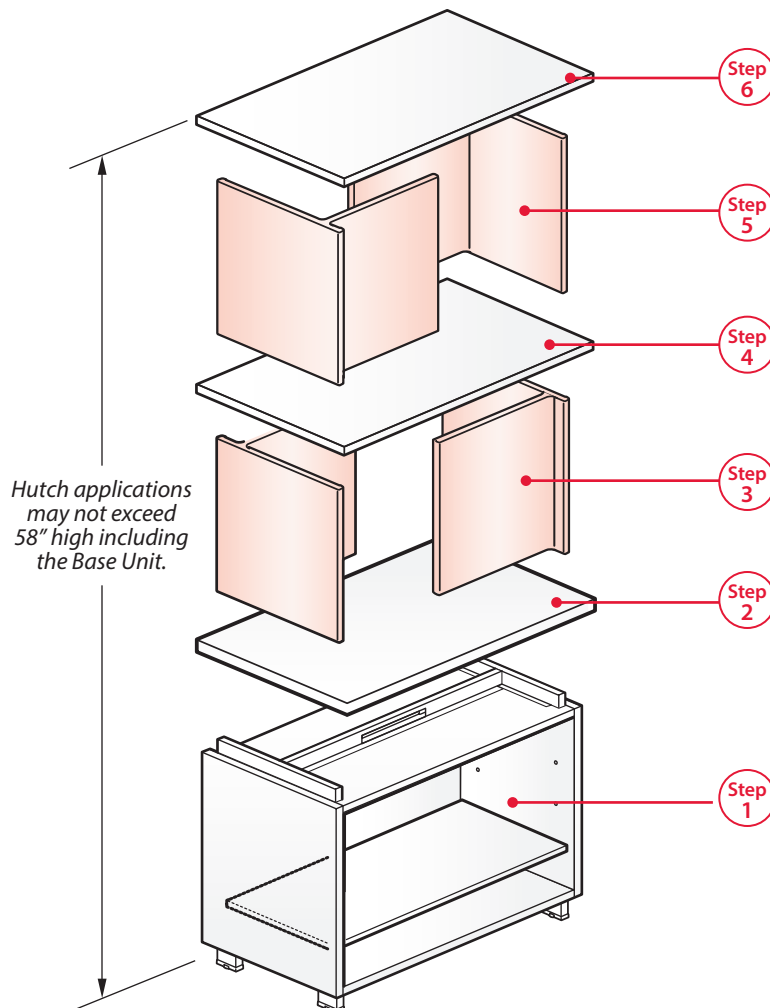

Note Refer to the following pages for additional planning models for specific Stanchion Kit / Hutch application guidelines.

Product Application – Beside Storage

Six Easy Steps – Designing A Stanchion Kit Mounted Overhead Storage Unit Application

- Step 1 Beside Base Unit –**
Beside Base Unit is used to support a Stanchion Kit.
Note: Stanchion Kits are not for use on desking Worksurfaces/Return Worksurfaces, panel mounted Adaptable Worksurfaces, or Desk Shells.
- Step 2 Beside Storage Top –** (required; separately specify)
A separately specified Beside Storage Top is a required component above a Beside Base Unit.
- Step 3 Beside Stanchion Kit –** (located in a one-high position)
A Beside Stanchion Kit may be used above a Beside Base Unit with Storage Top for additional vertical storage. Available in multiple configurations and sizes.
- Step 4 Beside Hutch Shelf –** (required; separately specify)
A separately specified 3/4" thick Hutch Shelf encloses the top of the Stanchion Kit creating a Hutch Application. When stacking Stanchion Kits above one another a Hutch Shelf is required between Stanchion Kits.
Note: Beside Hutch Shelf must be the same nominal width as the Stanchion Kit.
- Step 5 Beside Stanchion Kit –** (located in two-high position)
A Beside Stanchion Kit may be used above one another for additional vertical storage.
- Step 6 Beside Overhead Storage Unit –** (required; separately specify)
A separately specified Overhead Storage Unit encloses the top of the Stanchion Kit creating a Hutch Application. The Overhead Storage Unit is installed above the above a Stanchion Kit; a Hutch Shelf is not required below the Overhead Storage Unit.

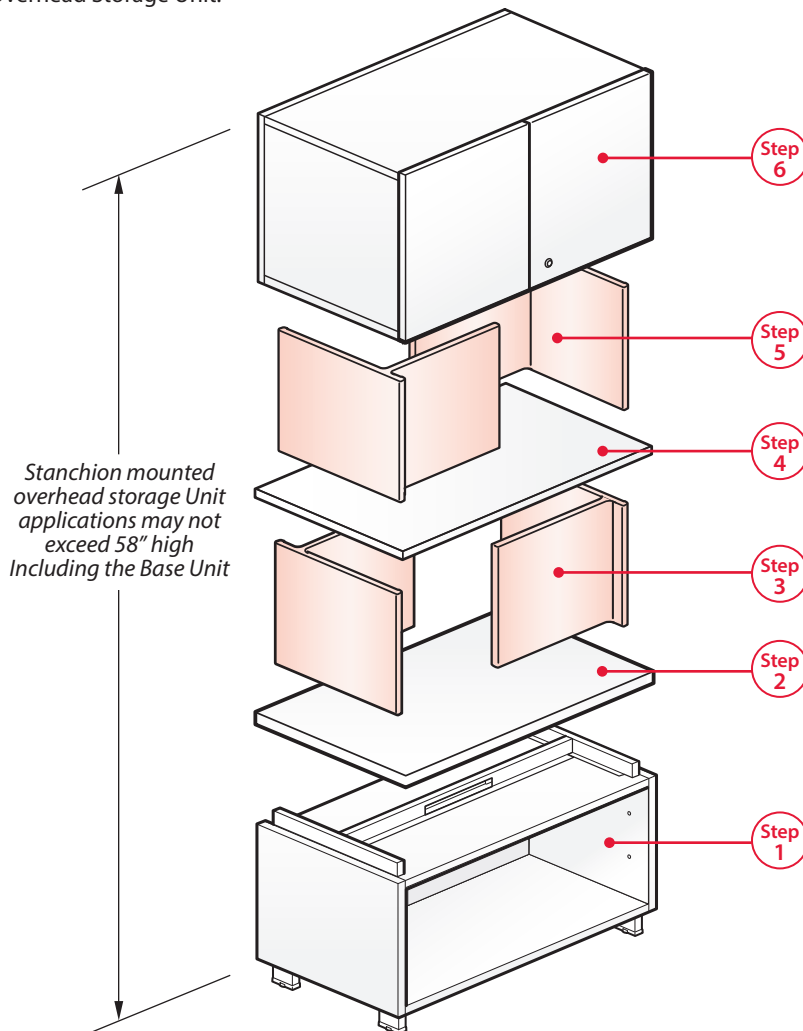

Note Refer to the following pages for additional planning models for specific Stanchion Kit / Hutch application guidelines.

Product Application – Beside Storage

Storage Based Planning – One-High Hutch Applications

- ✓ Do** **Application 1-A**
- (1) Stanchion Kit – same nominal width as (1) Base Unit and Storage Top.

Planning Model:

- (1) Base Unit
- (1) Storage Top
- (1) Stanchion Kit
- (1) Hutch Shelf

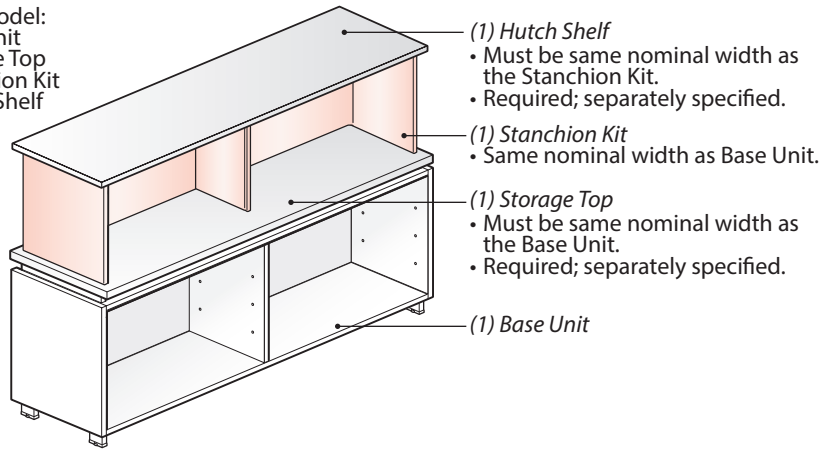

Application Alternative:

- The Stanchion Kit and the Base Unit may face in the same or opposite direction.

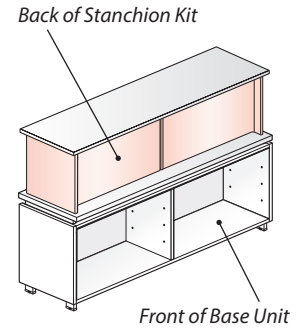

Same application as above with the following exceptions:

- ✓ Do** **Application 1-B**
- (1) Storage Top spans (2) Base Units

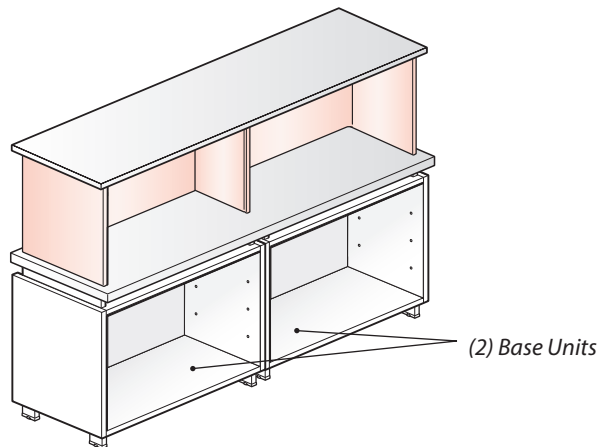

Application Alternative:

- The Stanchion Kit and the Base Units may face in the same or opposite directions.

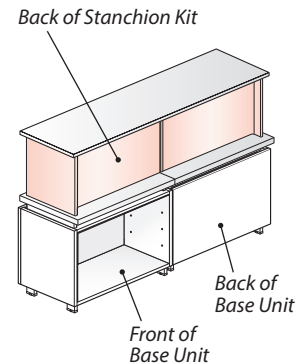

- ⊘ Don't** **Application 1-C – Not a valid application with two Storage Tops.**
- (2) Base Units and (2) Storage Tops – each Storage Top has the same nominal width as each Base Unit.

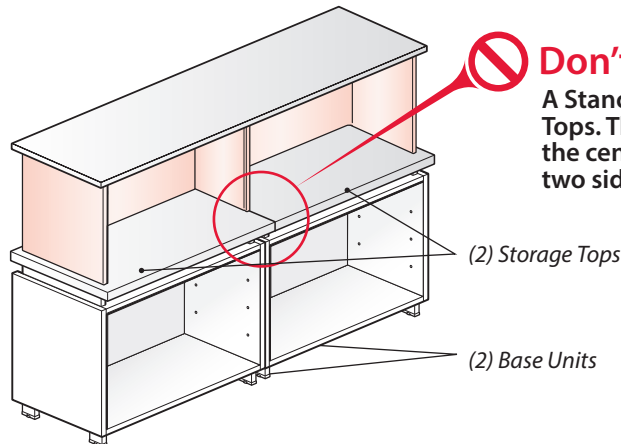

⊘ Don't

A Stanchion Kit may not span multiple Storage Tops. The Stanchion Kit vertical panel located in the center may not be installed at the seam of two side-by-side Beside Storage Tops.

Note • A Stanchion Kit with the same nominal width as the Storage Top includes an installation template; installation requires field drilling.

Tip • The combined height of the Base Unit, Storage Top, Stanchion Kits, and Hutch Top(s) may not exceed a maximum height of 58".
 • A Hutch Shelf encloses the top of a Stanchion Kit creating a hutch application.

Product Application – Beside Storage

Storage Based Planning – One-High Hutch Applications

- Do** **Application 2-A**
 • (2) Stanchion Kits – half the nominal width of the Base Unit and the Storage Top.

Planning Model:
 • (1) Base Unit
 • (1) Storage Top
 • (2) Stanchion Kits
 • (2) Hutch Shelves

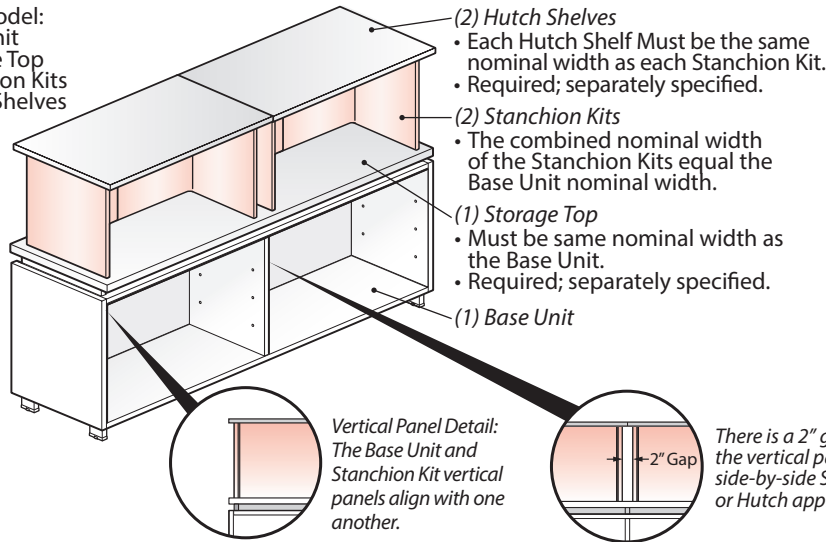

Application Alternative:

- The Stanchion Kits and the Base Unit may face in the same or opposite directions.

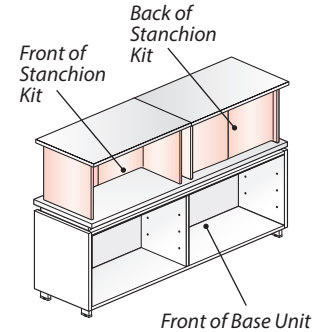

Same application as above with the following exceptions:

- Do** **Application 2-B**
 • (2) Base Units

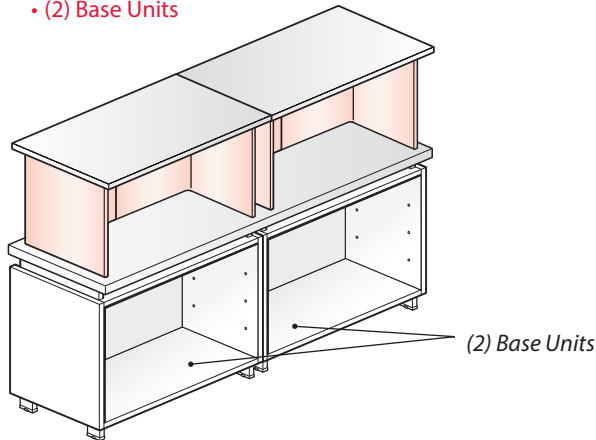

Application Alternative:

- The Stanchion Kits and the Base Units may face in the same or opposite directions.

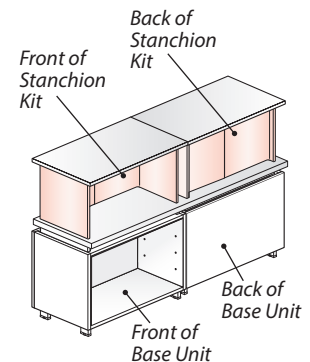

- Do** **Application 2-C**
 • (2) Base Units and (2) Storage Tops

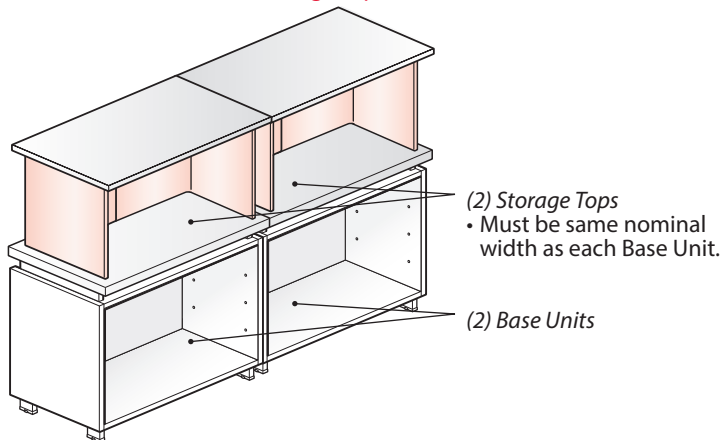

Application Alternative:

- The Stanchion Kits and the Base Units may face in the same or opposite directions.

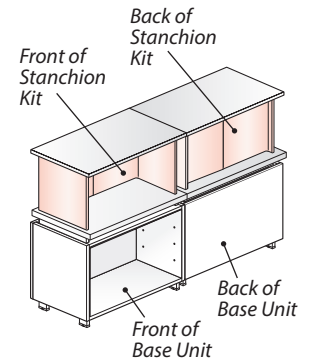

Note • A Stanchion Kit with the same nominal width as the Storage Top includes an installation template; installation requires field drilling.

Tip • The combined height of the Base Unit, Storage Top, Stanchion Kits, and Hutch Top(s) may not exceed a maximum height of 58".
 • A Hutch Shelf encloses the top of a Stanchion Kit creating a hutch application.

Product Application – Beside Storage

Storage Based Planning – One-High Hutch Applications

- ✓ Do** **Application 3-A**
 • (1) Stanchion Kit – half the nominal width of the Base Unit and the Storage Top.

Planning Model:
 • (1) Base Unit
 • (1) Storage Top
 • (1) Stanchion Kit
 • (1) Hutch Shelf

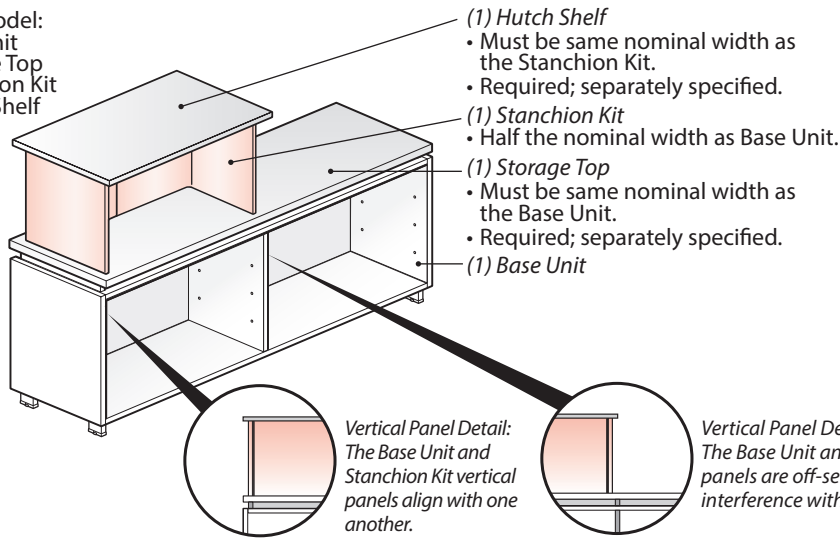

Application Alternative:

- The Stanchion Kit and the Base Unit may face in the same or opposite directions.

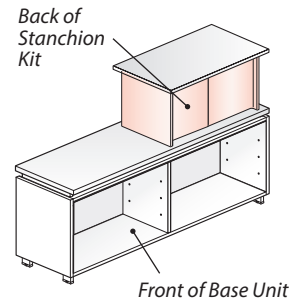

Same application as above with the following exceptions:

- ✓ Do** **Application 3-B**
 • (2) Base Units

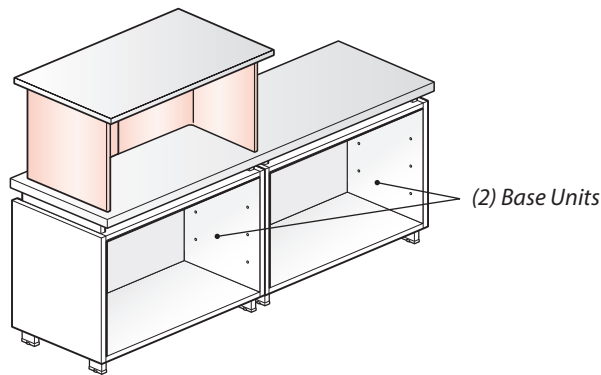

Application Alternative:

- The Stanchion Kit and the Base Units may face in the same or opposite directions.

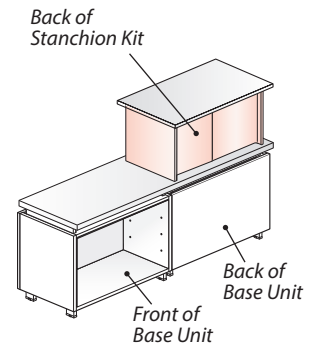

- ✓ Do** **Application 3-C**
 • (2) Base Units and (2) Storage Tops

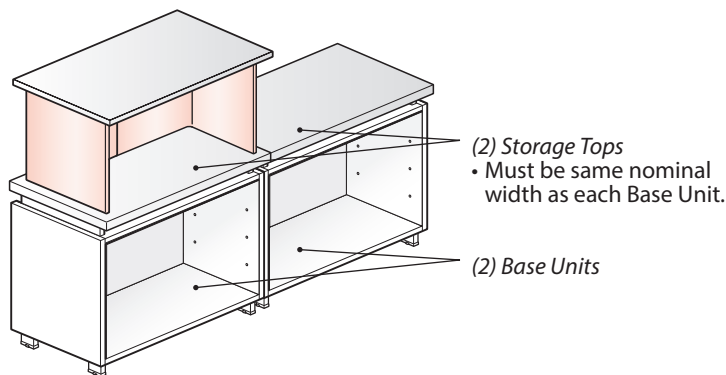

Application Alternative:

- The Stanchion Kit and the Base Units may face in the same or opposite directions.

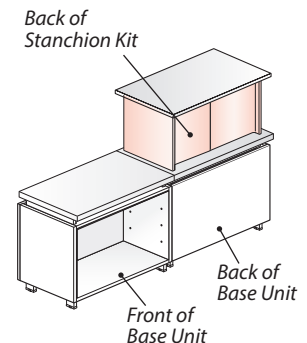

Note • A Stanchion Kit with the same nominal width as the Storage Top includes an installation template; installation requires field drilling.

Tip • The combined height of the Base Unit, Storage Top, Stanchion Kits, and Hutch Top(s) may not exceed a maximum height of 58".
 • A Hutch Shelf encloses the top of a Stanchion Kit creating a hutch application.

Product Application – Beside Storage

Storage Based Planning – One-High Hutch Applications

- Do** **Application 4-A / Off-Modular**
 • (1) Stanchion Kit – half the nominal width of the Base Unit and the Storage Top.

- Planning Model:
 • (1) Base Unit
 • (1) Storage Top
 • (1) Stanchion Kit
 • (1) Hutch Shelf

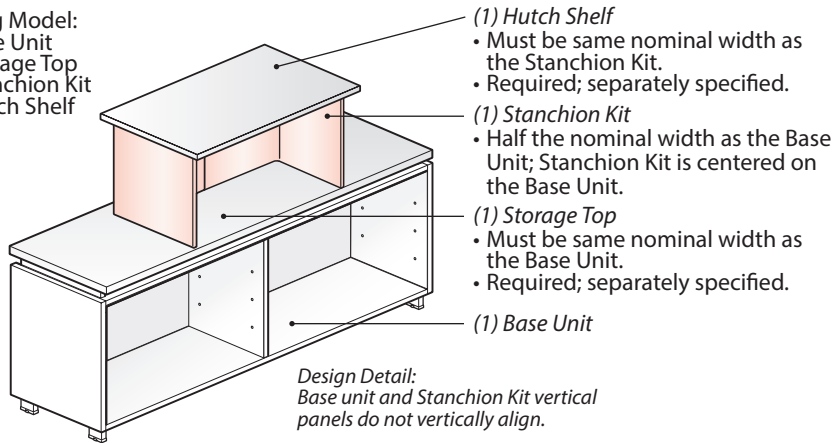

Application Alternative:

- The Stanchion Kit and the Base Unit may face in the same or opposite directions.

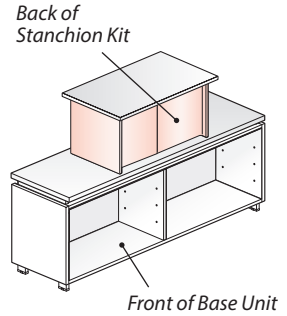

Same Application as above with the following exceptions:

- Do** **Application 4-B / Off-Modular**
 • (2) Base Units

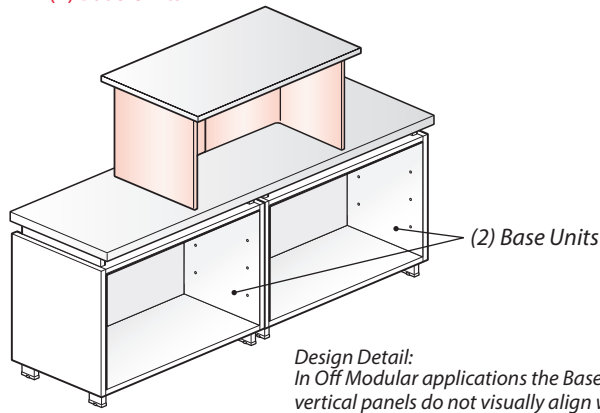

Application Alternative:

- The Stanchion Kit and the Base Units may face in the same or opposite directions.

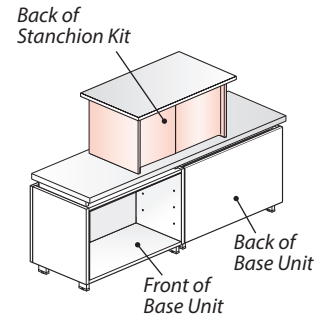

- Don't** **Application 4-C / Off-Modular – Not a valid application with two Storage Tops.**
 • (2) Base Units and (2) Storage Tops

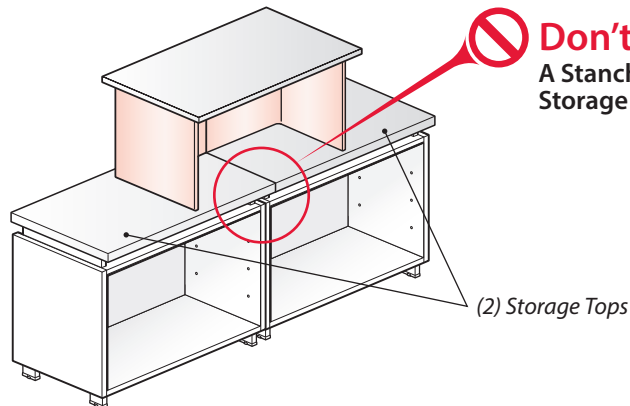

Note • A Stanchion Kit with the same nominal width as the Storage Top includes an installation template; installation requires field drilling.

Tip • The combined height of the Base Unit, Storage Top, Stanchion Kits, and Hutch Top(s) may not exceed a maximum height of 58".
 • A Hutch Shelf encloses the top of a Stanchion Kit creating a hutch application.

Product Application – Beside Storage

Storage Based Planning – One-High Hutch Applications



Do

Application 5-A / Off-Modular

- (2) Stanchion Kits – The combined nominal width of the Stanchion Kits are less than the Base Unit nominal width.
- Stanchion Kits are located at each end of the Base Unit.

- Planning Model:
- (1) Base Unit
 - (1) Storage Top
 - (2) Stanchion Kits
 - (2) Hutch Shelves

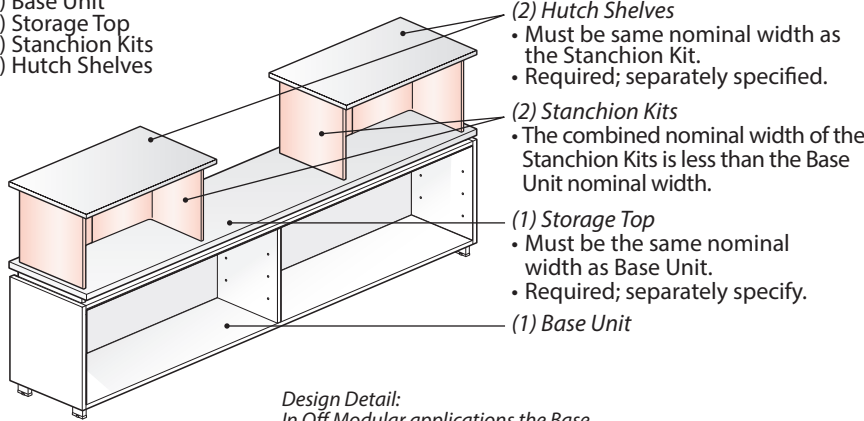

Design Detail:
In Off Modular applications the Base Unit and Stanchion Kit vertical panels do not visually align with each other.

Application Alternative:

- The Stanchion Kits and the Base Unit may face in the same or opposite directions.

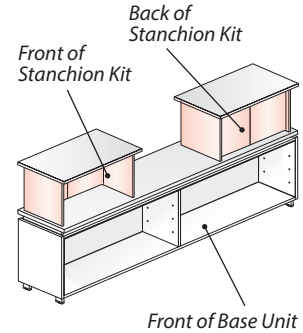

Same as Application 5A with the following exceptions:



Do

Application 5-B / Off-Modular

- (2) Base Units

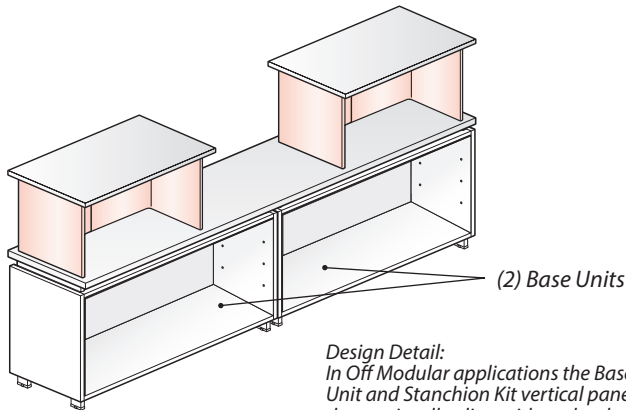

Design Detail:
In Off Modular applications the Base Unit and Stanchion Kit vertical panels do not visually align with each other.

Application Alternative:

- The Stanchion Kits and the Base Units may face in the same or opposite directions.

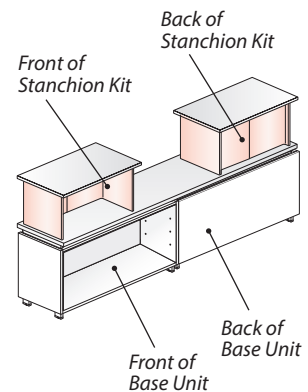

Note

- A Stanchion Kit with the same nominal width as the Storage Top includes an installation template; installation requires field drilling.

Tip

- The combined height of the Base Unit, Storage Top, Stanchion Kits, and Hutch Top(s) may not exceed a maximum height of 58".
- A Hutch Shelf encloses the top of a Stanchion Kit creating a hutch application.

Product Application – Beside Storage

Storage Based Planning – One-High Hutch Applications

Same as Application 5A with the following exceptions:

- ✔ **Do**
 - Application 5-C / Off-Modular**
 - (2) Base Units and (2) Storage Tops with the same nominal width.

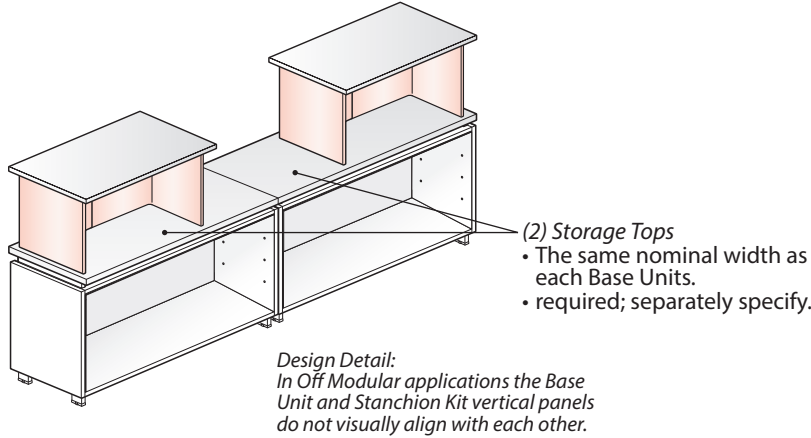

Application Alternative:

- The Stanchion Kits and the Base Units may face in the same or opposite directions.

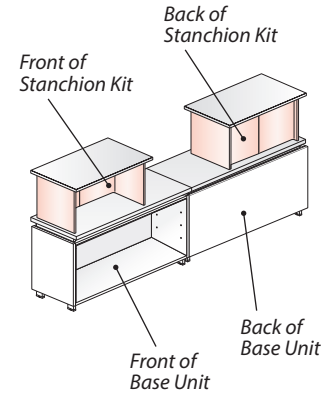

Same as Application 5A with the following exceptions:

- ⊘ **Don't**
 - Application 5-D / Off-Modular**
 - (1) Hutch Shelf spans (2) Stanchion Kits.

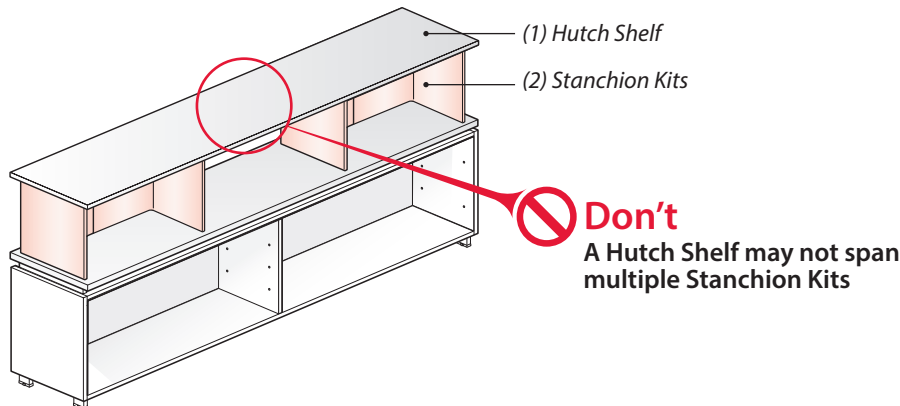

Note • A Stanchion Kit with the same nominal width as the Storage Top includes an installation template; installation requires field drilling.

Tip • The combined height of the Base Unit, Storage Top, Stanchion Kits, and Hutch Top(s) may not exceed a maximum height of 58".
• A Hutch Shelf encloses the top of a Stanchion Kit creating a hutch application.

Product Application – Beside Storage

Storage Based Planning – Two-High Hutch Applications



Do

Application 6-A

- (2) Stanchion Kits in a stacked application above (1) Base Unit – each Stanchion Kit is the same nominal width as the Base Unit.

- Planning Model:
- (1) Base Unit
 - (1) Storage Top
 - (2) Stanchion Kits
 - (2) Hutch Shelves

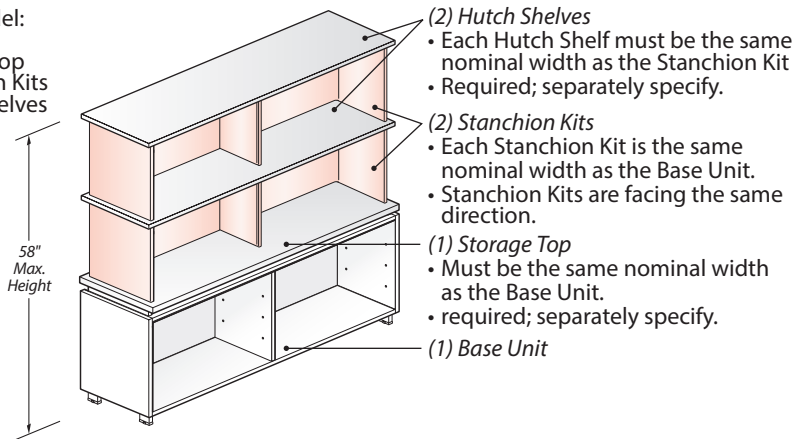

Application Alternative:

- The Stanchion Kits and the Base Unit may face in the same or opposite directions.

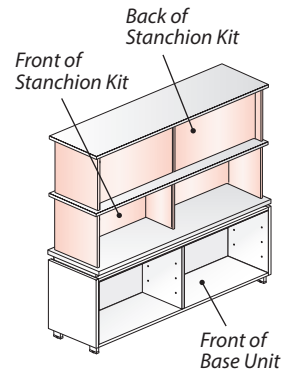

Same application as above with the following exceptions:



Do

Application 6-B

- (2) Base Units.

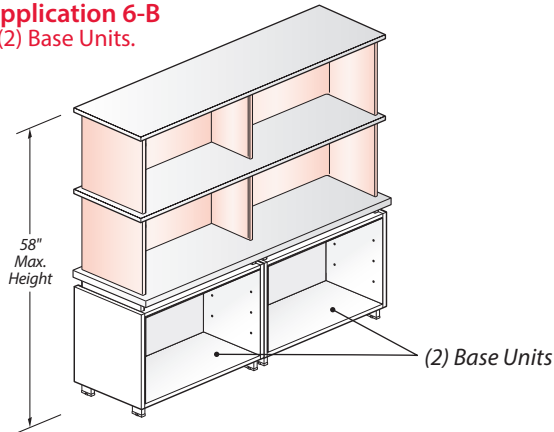

Application Alternative:

- The Stanchion Kits and the Base Units may face in the same or opposite directions.

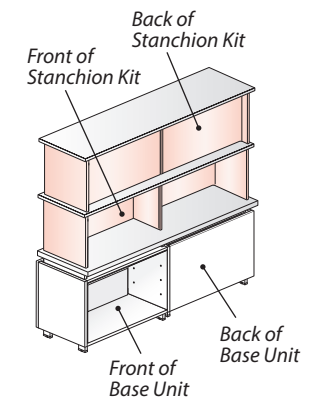

Don't

Application 6-C

- (2) Storage Tops and (2) Base Units – Storage Tops are same nominal width as each Base Unit.

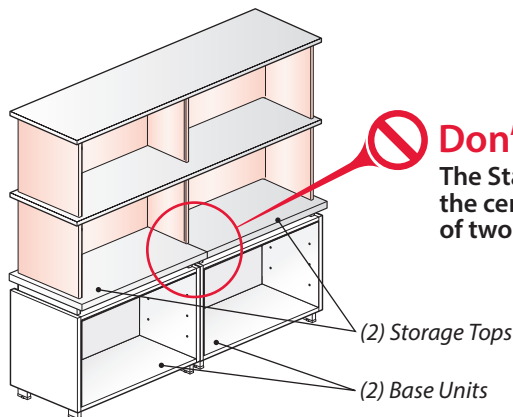

Don't

The Stanchion Kit vertical panel located in the center may not be installed at the seam of two side-by-side Beside Storage Tops.

Note

- A Stanchion Kit with the same nominal width as the Storage Top includes an installation template; installation requires field drilling.

Tip

- The combined height of the Base Unit, Storage Top, Stanchion Kits, and Hutch Top(s) may not exceed a maximum height of 58".
- A Hutch Shelf encloses the top of a Stanchion Kit creating a hutch application.

Product Application – Beside Storage

Storage Based Planning – Two-High Hutch Applications



Do

Application 7-A

- (2) Stanchion Kits in a stacked application
- The one-high Stanchion Kit is the same nominal width as the Base Unit. The two-high Stanchion Kit is half the nominal width as the one-high Stanchion Kit and may be located above either end of the Base Unit.

- Planning Model:
- (1) Base Unit
 - (1) Storage Top
 - (2) Stanchion Kits
 - (2) Hutch Shelves

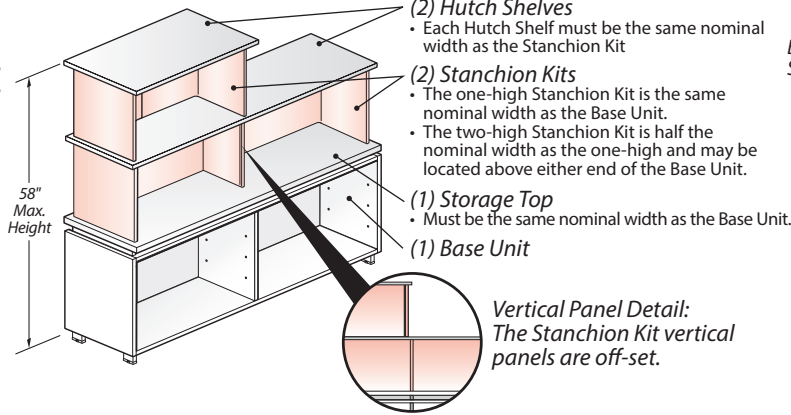

Application Alternative:

- The Stanchion Kits and the Base Unit may face in the same or opposite directions.

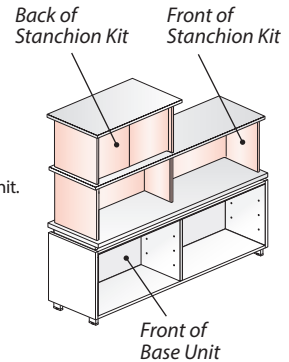

Same application as above with the following exceptions:



Do

Application 7-B

- (2) Base Units

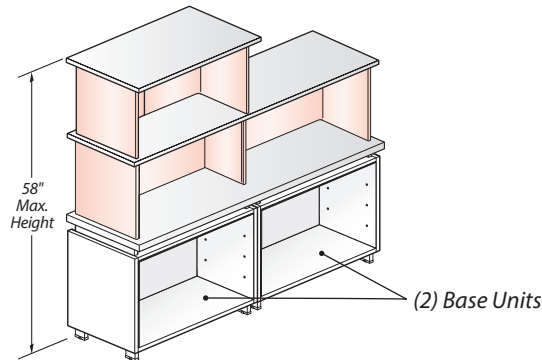

Application Alternative:

- The Stanchion Kits and the Base Units may face in the same or opposite directions.

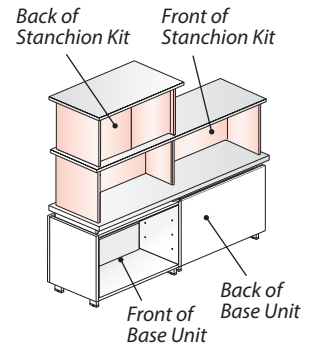

Don't

Application 7-C

- (2) Storage Tops and (2) Base Units – each Storage Top is the same nominal width as each Base Unit.

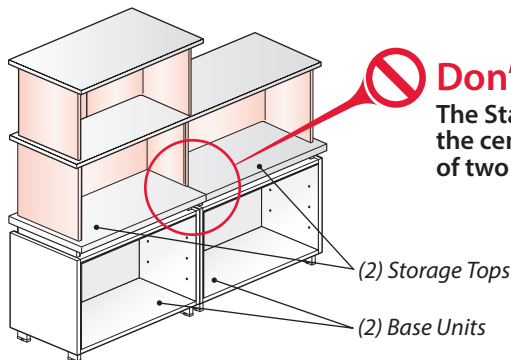

Don't

The Stanchion Kit vertical panel located in the center may not be installed at the seam of two side-by-side Beside Storage Tops.

Note

- A Stanchion Kit with the same nominal width as the Storage Top includes an installation template; installation requires field drilling.

Tip

- The combined height of the Base Unit, Storage Top, Stanchion Kits, and Hutch Top(s) may not exceed a maximum height of 58".
- A Hutch Shelf encloses the top of a Stanchion Kit creating a hutch application.

Product Application – Beside Storage

Storage Based Planning – Two-High Hutch Applications



Do

Application 8-A

- (2) Stanchion Kits in a stacked application – Each Stanchion Kit is half the nominal width as the Base Unit.
- Stanchion Kits may be located above either end of the Base Unit.

- Planning Model:
- (1) Base Unit
 - (1) Storage Top
 - (2) Stanchion Kits
 - (2) Hutch Shelves

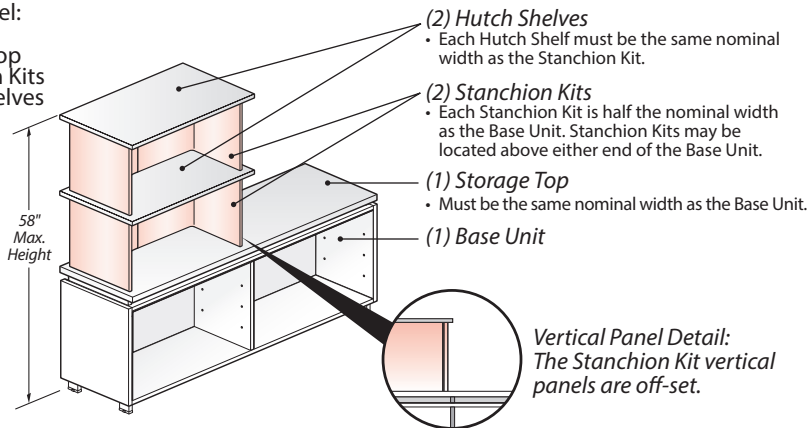

Application Alternative:

- The Stanchion Kits and the Base Unit may face in the same or opposite directions.

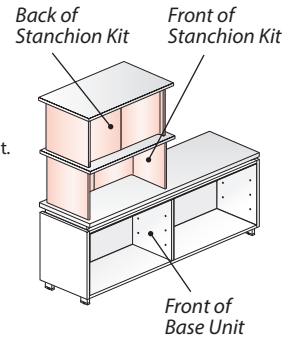

Same application as above with the following exceptions:



Do

Application 8-B

- (2) Base Units

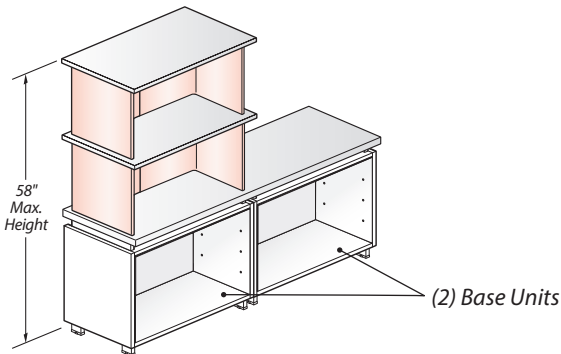

Application Alternative:

- The Stanchion Kits and the Base Units may face in the same or opposite directions.

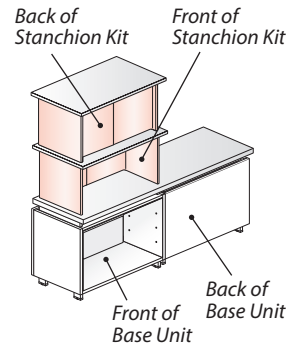

Do

Application 8-C

- (2) Storage Tops and (2) Base Units – each Storage Top is the same nominal width as each Base Unit.

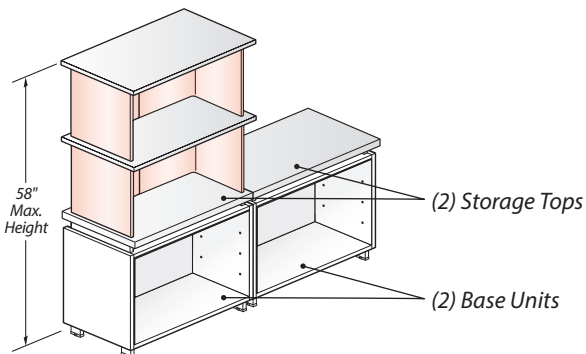

Application Alternative:

- The Stanchion Kits and the Base Units may face in the same or opposite directions.

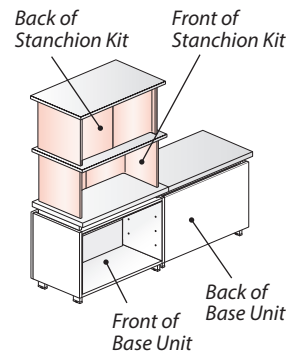

Note

- A Stanchion Kit with the same nominal width as the Storage Top includes an installation template; installation requires field drilling.

Tip

- The combined height of the Base Unit, Storage Top, Stanchion Kits, and Hutch Top(s) may not exceed a maximum height of 58".
- A Hutch Shelf encloses the top of a Stanchion Kit creating a hutch application.

Product Application – Beside Storage

Storage Based Planning – Two-High Hutch Applications



Do

Application 9-A / Off-Modular Tiered

- (2) Stanchion Kits in a tiered stacked application – the one-high Stanchion Kit may be 6" less than the Base Unit width.
- The two-high Stanchion Kit may be 12" less than the one-high Stanchion Kit width.

Application Alternative:

- The Stanchion Kits and the Base Unit may face in the same or opposite directions.

- Planning Model:
- (1) Base Unit
 - (1) Storage Top
 - (2) Stanchion Kits
 - (2) Hutch Shelves

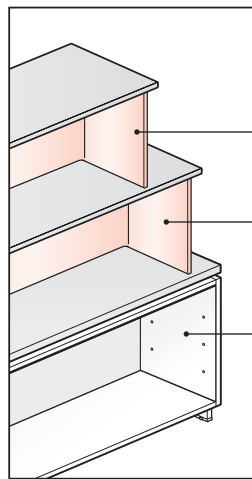
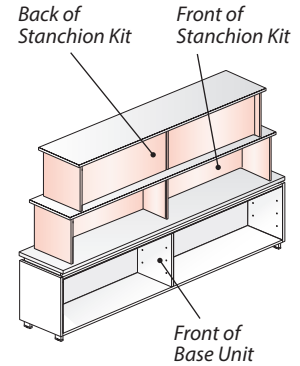
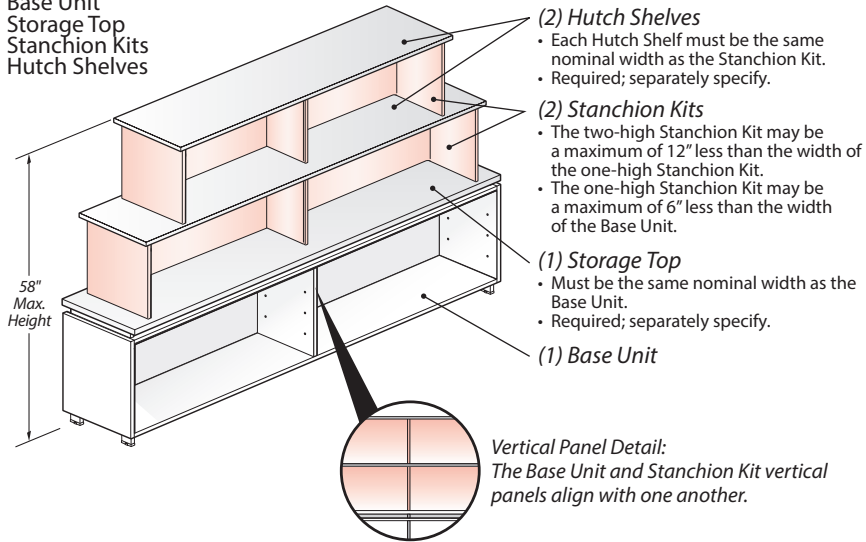

Tiered Width - Example:

- **54" wide – Two-High Stanchion Kit**
• Maximum of 12" less than the width of the one-high Stanchion Kit.
- **66" wide – One-High Stanchion Kit**
• Maximum of 6" less than the width of the Base Unit.
- **72" wide – Base Unit**

Note

- A Stanchion Kit with the same nominal width as the Storage Top includes an installation template; installation requires field drilling.

Tip

- The combined height of the Base Unit, Storage Top, Stanchion Kits, and Hutch Top(s) may not exceed a maximum height of 58".
- A Hutch Shelf encloses the top of a Stanchion Kit creating a hutch application.

Product Application – Beside Storage

Storage Based Planning – Two-High Hutch Applications

Same as Application 9-A with the following exceptions:

-  **Do** **Application 9-B / Off-Modular Tiered**
 • (2) Base Units

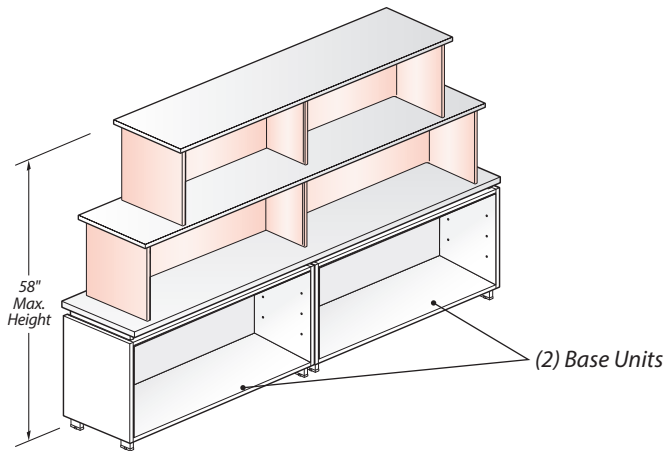

Application Alternative:

- The Stanchion Kits and the Base Units may face in the same or opposite directions.

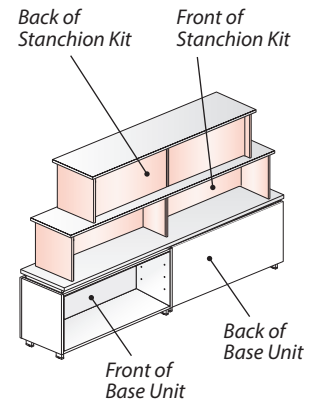

-  **Don't** **Application 9-C / Off-Modular Tiered**
 • (2) Storage Tops and (2) Base Units – each Storage Top is the same nominal width as each Base Unit.

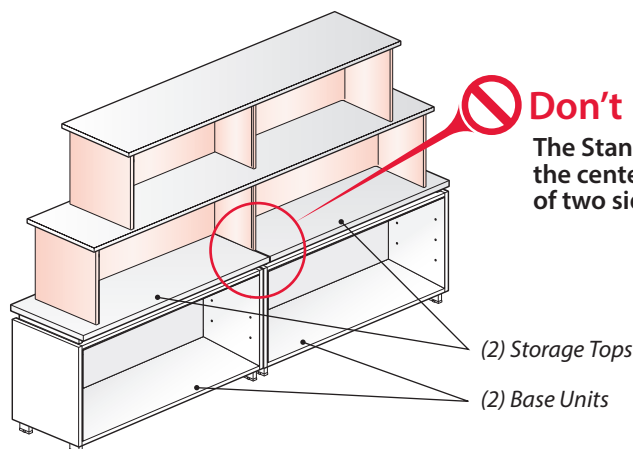

The Stanchion Kit vertical panel located in the center may not be installed at the seam of two side-by-side Beside Storage Tops.

Note • A Stanchion Kit with the same nominal width as the Storage Top includes an installation template; installation requires field drilling.

Tip • The combined height of the Base Unit, Storage Top, Stanchion Kits, and Hutch Top(s) may not exceed a maximum height of 58".
 • A Hutch Shelf encloses the top of a Stanchion Kit creating a hutch application.

Product Application – Beside Storage

Storage Based Planning – Back-To-Back Base Units Hutch Applications



Do

Application 10-A

- (1) Stanchion Kit - Center Mounted on the back-to-back Base Units without Screens or Tool Rails.
- Stanchion Kit user access may be in the same or opposite directions.

- Planning Model:
- (2) Base Units
 - (2) Storage Tops
 - (1) Stanchion Kit
 - (1) Hutch Shelf

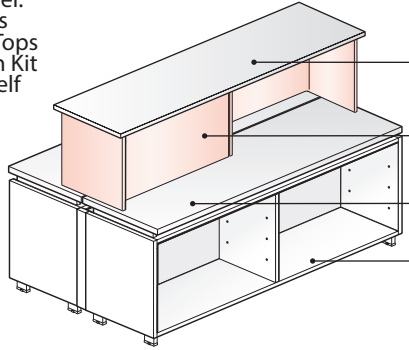

(1) Hutch Shelves

- Each Hutch Shelf must be the same nominal width as the Stanchion Kit

(1) Stanchion Kit

- The one-high Stanchion Kit is the same nominal width as the Base Unit.

(2) Storage Tops

- Must be the same nominal width as the Base Unit.

(2) Base Units

Planning Model for center mounted Stanchion Kits:

- The guidelines for on-module and off-module; one and two high Stanchion Kit applications in the previous pages apply to a center mounted Stanchion Kit condition.

Same application as above with the following exceptions:



Do

Application 10-B

- (4) Base Units

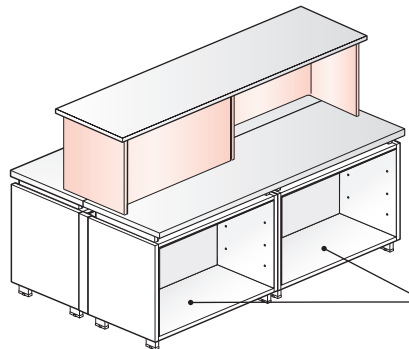

(2) Base Units



Don't

Application 10-C

- (4) Base Units and (4) Storage Tops – each Storage Top is the same nominal width as each Base Unit.

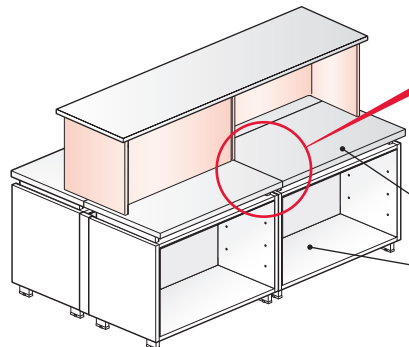

Don't

The Stanchion Kit vertical panel located in the center may not be installed at the seam of two side-by-side Beside Storage Tops.

(4) Storage Tops

(4) Base Units

Note

- A Stanchion Kit with the same nominal width as the Storage Top includes an installation template; installation requires field drilling.



Tip

- The combined height of the Base Unit, Storage Top, Stanchion Kits, and Hutch Top(s) may not exceed a maximum height of 58".
- A Hutch Shelf encloses the top of a Stanchion Kit creating a hutch application.

Product Application – Beside Storage

Application Overview – Panel Mounted Overhead Storage Unit (OSU)

Overhead Storage Units can be panel mounted on top of a Compose, PREMISE or UniGroup Too panel.

Panel Mounted Application

Beside Overhead Storage Units can be mounted to a Compose, PREMISE or UniGroup Too panel. The Overhead Storage Unit is always center mounted on the top of a panel.

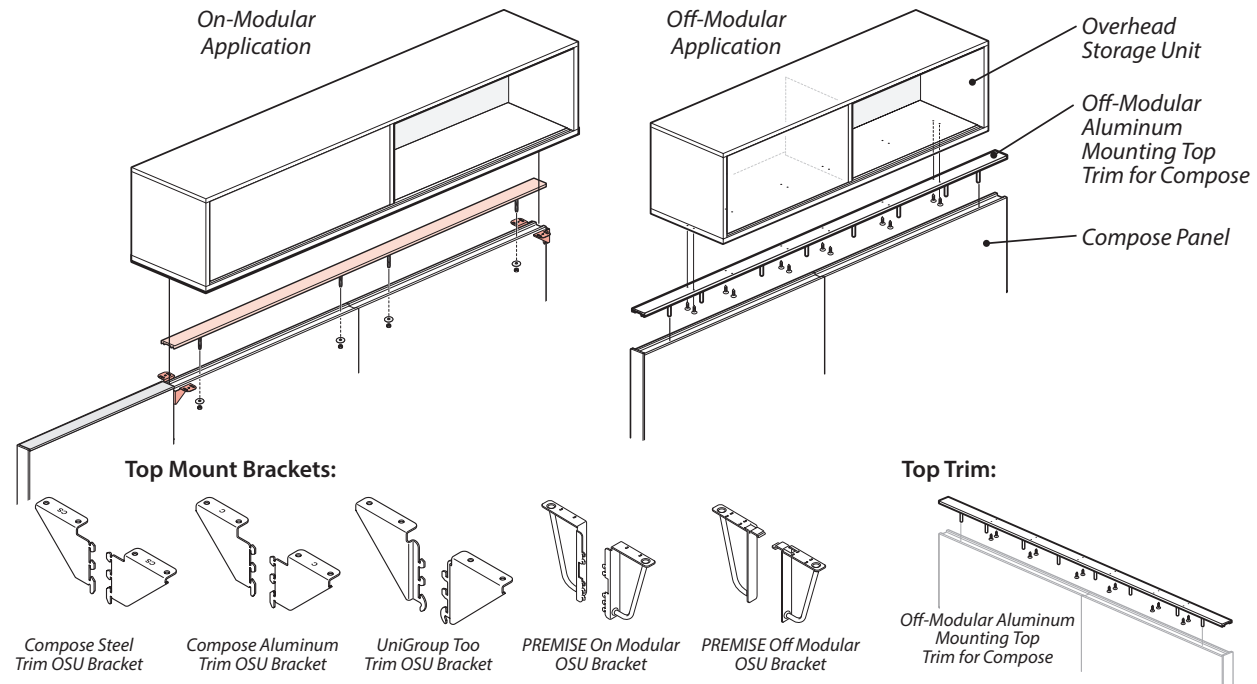

- In a panel mounted application the Beside OSU is always center mounted on the top of a panel.
- Panel mounted Overhead Storage Units are available for an on-modular or off-modular applications with separately specified application components.
 - For an on-modular Beside OSU application (fixed condition - OSU and panel are the same width) separately specify a systems application specific mounting bracket for a Compose, PREMISE or UniGroup Too application.
 - Off-modular Beside OSU applications are only for use with Compose panel system with aluminum top trim and PREMISE panel system with grooved trim. Separately specify the off-modular top trim for Compose. Top trim includes attachment hardware. Off-modular top trim is used in place of the standard Compose top trim.
 - Compose off-modular top trim (for off-modular OSU applications) is available in full profile aluminum, only.
- The overall height of Compose panel with Beside Overhead Storage Unit must not exceed 66"

Compose Panel Mounted Beside Overhead Storage Unit (OSU) Application Guidelines

- Beside OSU must follow the existing double-sided up-mount OSU support and load guidelines shown in the Compose specification guide.
- For use on a Compose full panel frame or a full panel frame with stack frame.
- Cannot be mounted on glass panels or glass stacks.
- Recommended for use on a 50" high Compose panel configuration; not for use on panel configurations greater than 50" high.
- Two return panels are required at each OSU end-of-run condition for a balanced application; results in a 3-way panel intersection (2-way panel intersection does not offer proper support for a center mounted OSU).
- If the panel application does not have worksurfaces the return panels must be at least 18" wide.
- Return panels must be same height as OSU panel spine.
- Length of OSU panel run must not exceed 8 feet.



Do

- LED light may be used in a panel mounted OSU application.
- Separately specified OSU ganging brackets are required for an on-modular and off-modular side-by-side Beside OSU application. Two brackets are required for every side-by-side OSU condition; catalog number QUUG-0000 includes one bracket.



Don't

- Adaptable Task Light cannot be used with a panel mounted Beside OSU.

Product Application – Beside Storage

Application Overview – Storage Based Desking Cluster With Single Depth Storage Spine

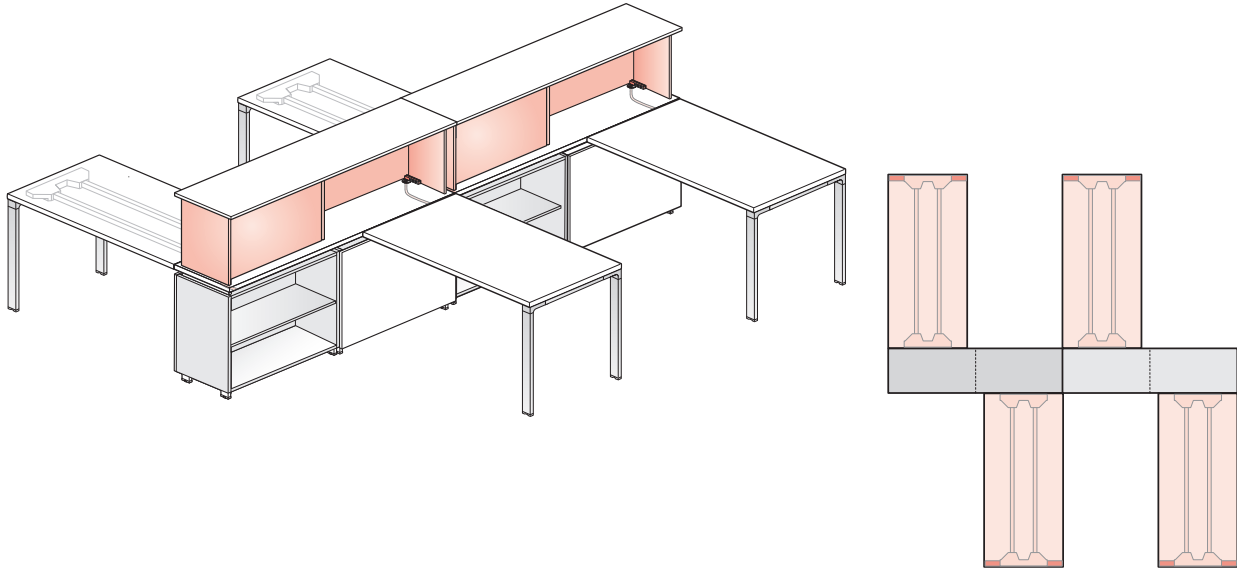

Simple Specification:

- Infeed to access building power location (uses two power connectors or any receptacle location on PDA).
- Power Distribution Assembly specified to match Base Unit width(s).
- Jumper(s) to continue power from one powered Base Unit to the next.
- Power Tap and Power Tap Bracket specified for power access

Desking – Worksurfaces, Legs and Brackets

Worksurfaces:

- Rectangular Worksurface



- Worksurface Alternatives:**
- Articulated Transition Worksurface
 - Wedge Worksurface
 - Bent Worksurface

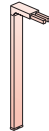

Legs:

- Straight Leg – Fixed
- Leg Alternatives:**
- Angled Leg
 - Adjustable Hoop Leg – Single Desk

Bracket:

- Flush Mount Plate

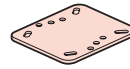

Storage – Base Units, Shelves, Brackets, Stanchions and Hutch Shelf

Base Units:

- Open – Single Width – Two-High

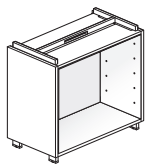

- Base Unit Alternatives:**
- Open Storage with Drawer
 - Drawer Combinations
 - Hinged Door
 - Hinged Door and Open Storage
 - Hinged Door and Drawer Combination
 - Single Sliding Door

Storage Top:

- Base Unit Storage Top

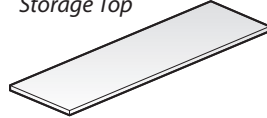

Shelf:

- Base Unit Accessory Shelf

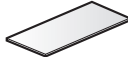

Stanchions:

- Stanchion Kit Q

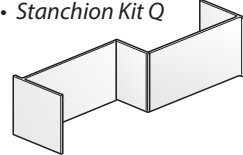

Brackets:

- Ganging Bracket Kit

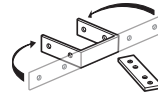

Shelf:

- Hutch Shelf

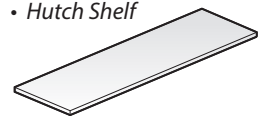

Electrical – Electrical Components and Accessories

Power In:

- Infeed Harness

Power In Alternatives:

- Infeed Harness
- Internal Power Base™ AI Base Feed
- Base Feed Module – Architectural Concealed – Hardwire Connection
- Top Feed

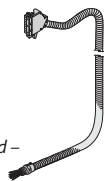

Power Through:

- PDA (Power Distribution Assembly)
- Jumper

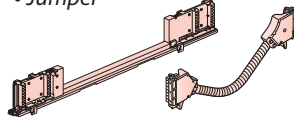

Power Out:

- Power Tap Horizontal
- Power Tap Bracket with Grommet Horizontal

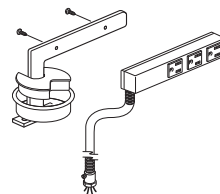

Power Out Alternatives:

- Power Tap Vertical
- Power Tap Bracket with Grommet Vertical
- Power Tap Bracket Fixed
- Power Tap Bracket Adjustable

Product Application – Critical Dimensions for Planning

Critical Dimensions for Planning - Hutch Application

- Hutch applications consist of separately specified components: Base Unit, Storage Top, Stanchion Kit and Hutch Shelf.
- Maximum stacking height with Base Units, Stanchion Kits and shelves should not exceed 58".
- Hutch shelf adds 3/4" to the Stanchion Kit height.
- Stanchion Kits are available in six heights: 10", 11", 12", 15", 16", 18".
- Base units are available three finished heights: one-high (17"), one and one-half high (23") and two high (29"). Finished height is for fully assembled Base Unit including a separately specified Storage Top.

Hutch Applications

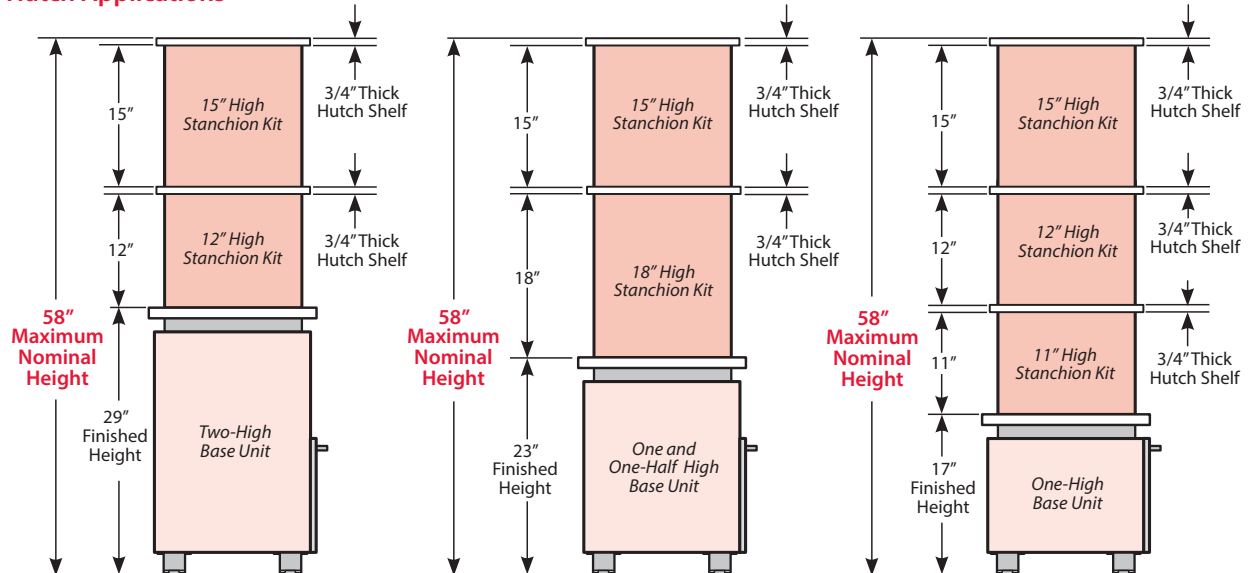

Stanchion Mounted Overhead Storage Unit Applications not to exceed 58" in height

- Stanchion Mounted Overhead Storage Unit Applications consist of separately specified components: Base Unit, Storage Top, Stanchion Kit, Hutch Shelf and Overhead Storage Unit.
- Maximum stacking height with Base Units, Stanchion Kits and shelves should not exceed 58".
- Hutch shelf adds 3/4" to the Stanchion Kit height.
- Stanchion Kits are available in six heights: 10", 11", 12", 15", 16", 18".
- Base units are available three finished heights: one-high (17"), one and one-half high (23") and two high (29"). Finished height is for fully assembled Base Unit including a separately specified Storage Top.

Stanchion Mounted Overhead Storage Unit Applications

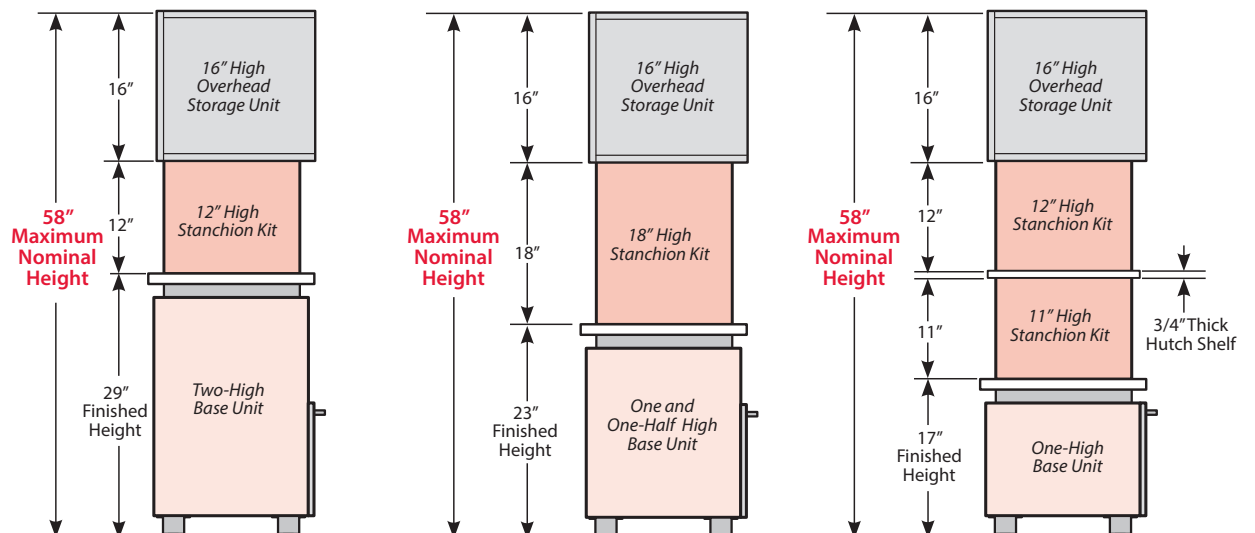

Note

- The Base Unit finished height includes the separately specified Storage Top. Do not add the Storage Top separately to figure maximum height.
- Above nominal dimensions are shown with glides fully recessed.

Product Application – Critical Dimensions for Planning

Critical Dimensions for Planning – Beside Storage Hutch with Compose Panels

Hutch & Compose Panels / Horizontal Alignment

Hutch storage applications are designed to complement Compose 50" and 58" panel heights. Using specific height Base Units and Stanchion Kits the hutch shelves at the top of the hutch configuration result in horizontal alignment with 50" and 58" Compose panels. Lower hutch shelves within the hutch configuration horizontally align with each other.

- Hutch applications consist of separately specified components: Base Unit, Storage Top, Stanchion Kit(s) and Hutch Shelf(s)
- Hutch applications not to exceed 58" in height
- Stanchion Kits may be located one above another with a Hutch Shelf between Stanchion Kits and at the top of the upmost Stanchion Kit.

50" High Compose Panel

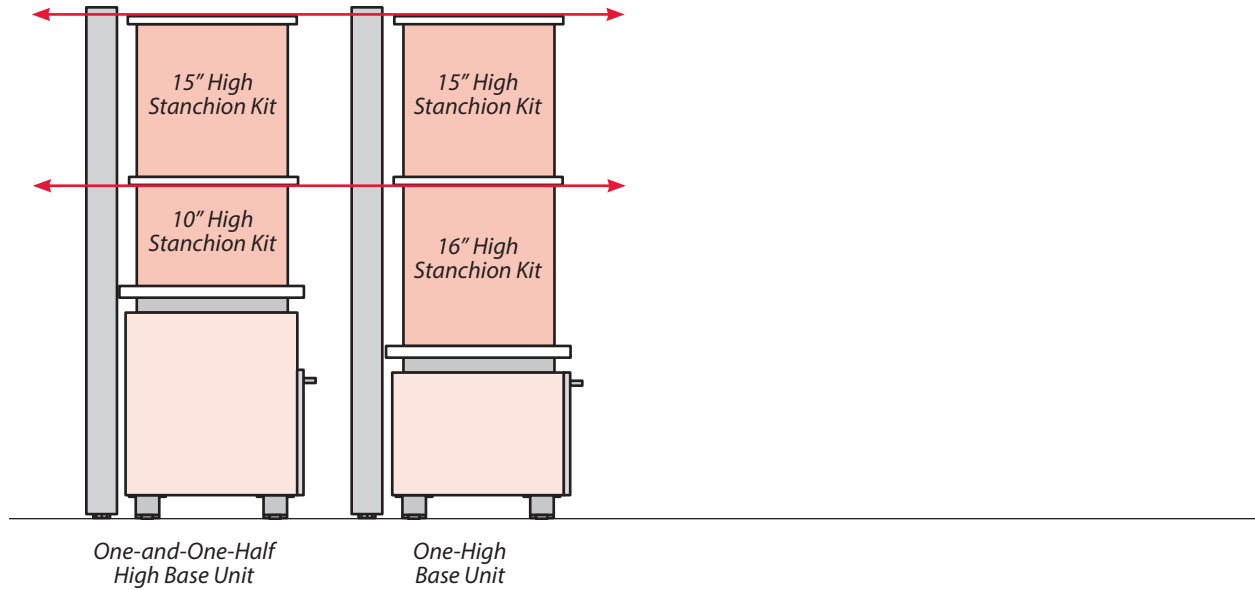

58" High Compose Panel

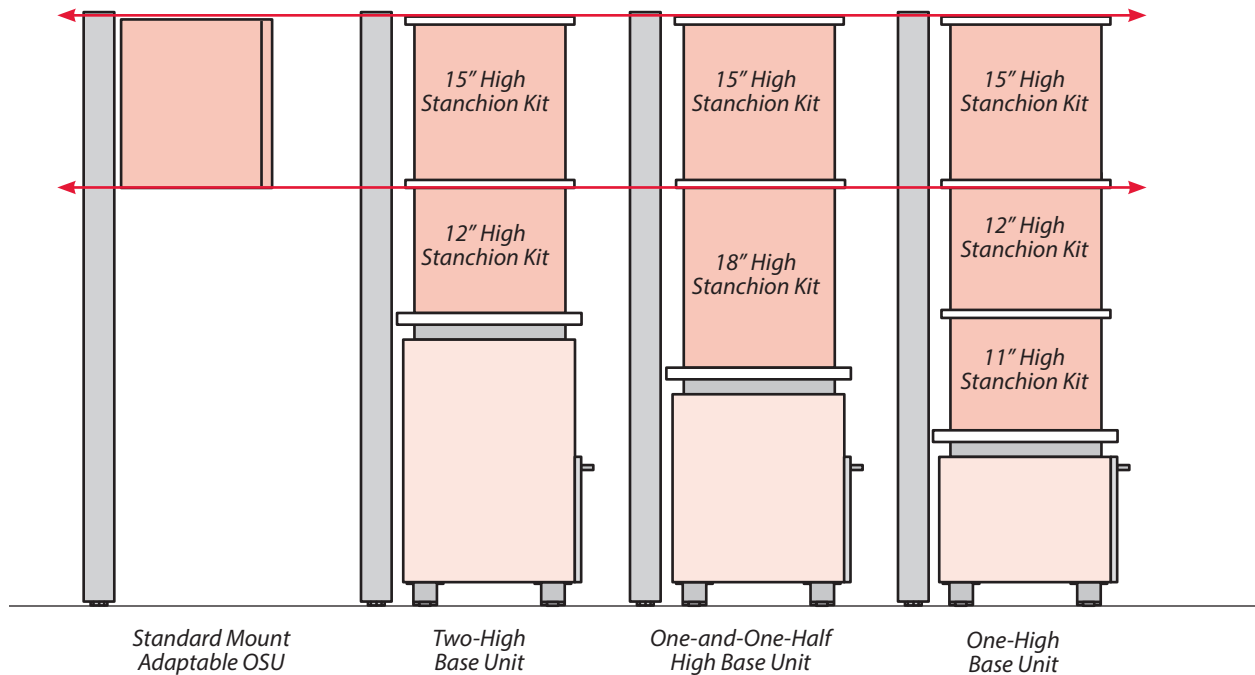

Note Stanchion Mounted Overhead Storage Unit and Hutch applications in a freestanding condition can be aligned with the top of a 50" or 58" high Compose panel. When attaching the storage to a Compose panel the storage will be elevated by 1/2" causing horizontal misalignment between the top of the panel and storage application. When planning take Panel glide adjustment range and floor condition into consideration.

Product Application – Beside Storage

Storage Pantry – Product Platform Compatibility Overview

The Beside Storage Pantry is designed to work with the following product platforms:

Adaptable Convergent Worksurface Applications

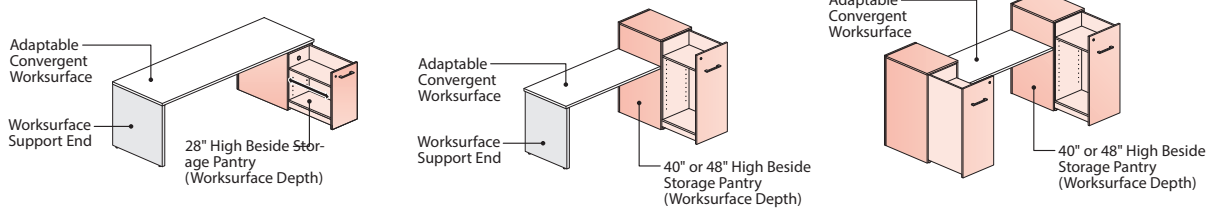

Compose Panel Applications

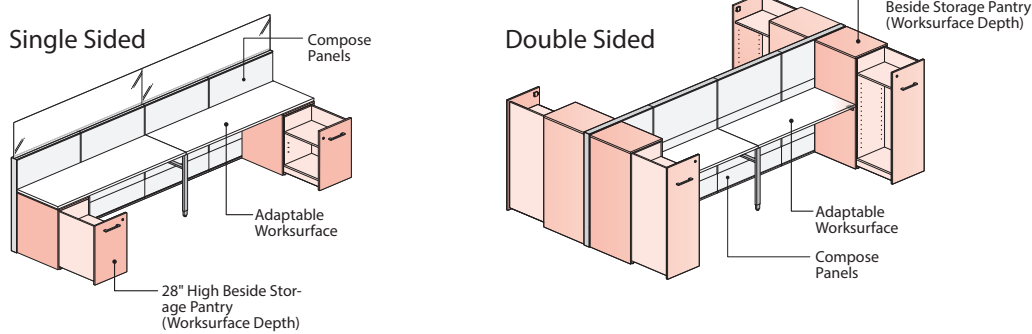

Reside Desking Applications

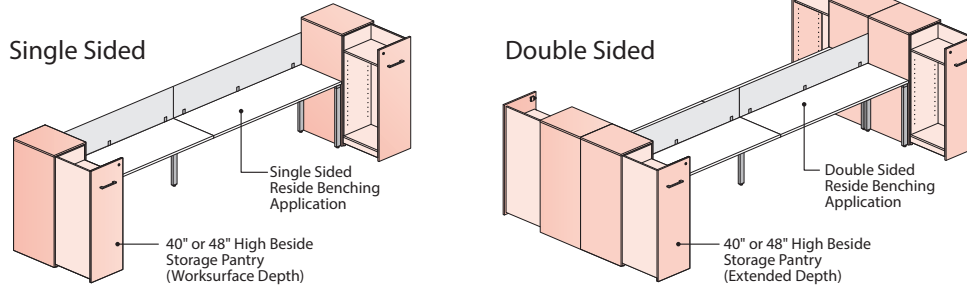

Intuity Benching Applications

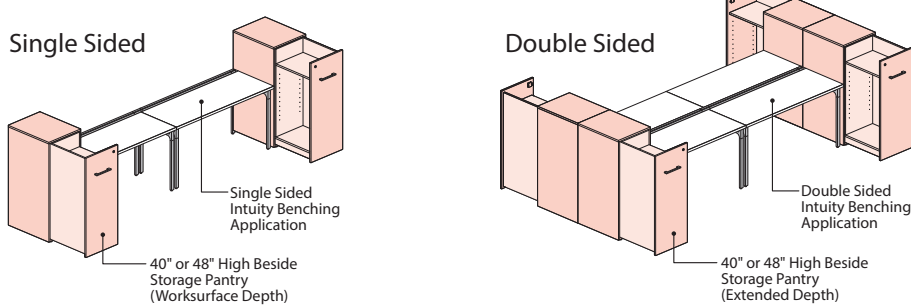

Planes Height Adjustable Table - Bench Application

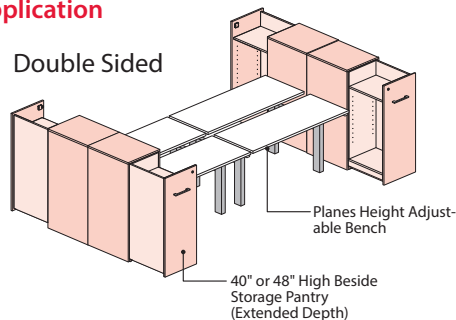

Product Application – Beside Storage

Storage Pantry – Product Planning Introduction

The Beside Storage Pantry is available in three heights, 28", 40" and 48". The 28" high storage pantry is available Worksurface Depth, only. The 40" and 48" high storage pantries are available Worksurface Depth and Extended Worksurface Depth. Storage pantries are available 12", 15" and 18" wide.

User Orientation Options

A Beside Storage Pantry has a full-height front sliding pull out storage compartment. The user accesses the storage compartment from one side of the pantry which requires Left or Right hand product specification.

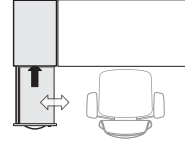

(L) Left Hand
If pantry is located on left-hand side of the user it is left-handed.

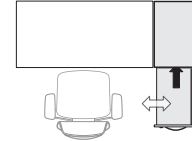

(R) Right Hand
If pantry is located on right-hand side of the user it is right-handed.

Specifying Pantry Depths

Extended Depth Storage Pantry is 1.5" deeper than the Worksurface Depth storage pantry for application planning purposes. The depth difference is driven by a single number, 1 or 2, in base one of the catalog number:

- 1 For Worksurface Depth
- 2 For Extended Depth

Catalog Number:

QLG1-4012- ZLWFQLNN

- Pantry Depth
- 1 – Worksurface Depth
- 2 – Extended Depth

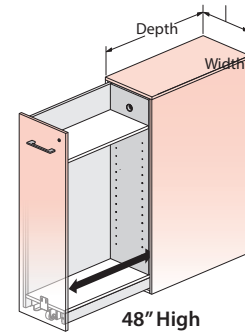
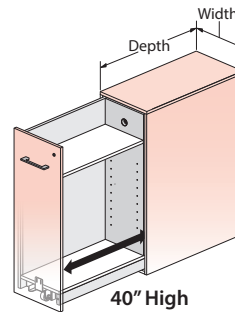
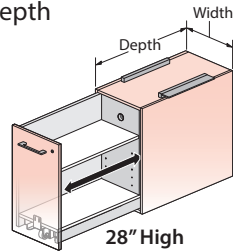

Left-Hand user orientation shown above

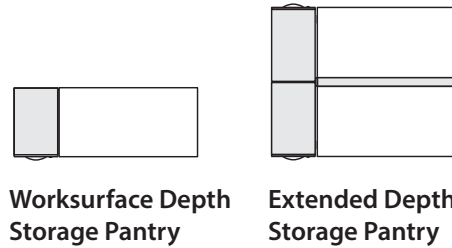

	28" High Storage Pantry	40" High Storage Pantry	48" High Storage Pantry
Worksurface Depth Nominal (Actual) • 24" (23.68") Deep • 30" (29.68") Deep	☑	☑	☑
Extended Depth Nominal (Actual") • 24" (25.5") Deep • 30" (31.5") Deep	Not Available	☑	☑

Product Application – Beside Storage

Planning Model Overview – Storage Pantry (28" High – Worksurface Depth)

In a Compose panel application a 28" high worksurface depth storage pantry must be attached below an adaptable worksurface. Not for use in a Reside, Intuity or Planes desking/benching application.

Compose Panel Based Application

- 28" high Storage Pantry is for use with an Adaptable rectangular worksurface.
- 12", 15" or 18" wide Worksurface Depth Storage pantry with panel to pantry bracket(s).

Single Sided Application

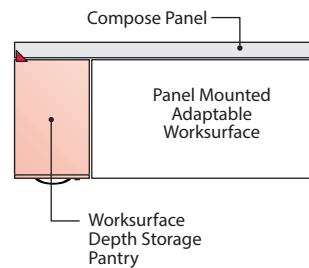
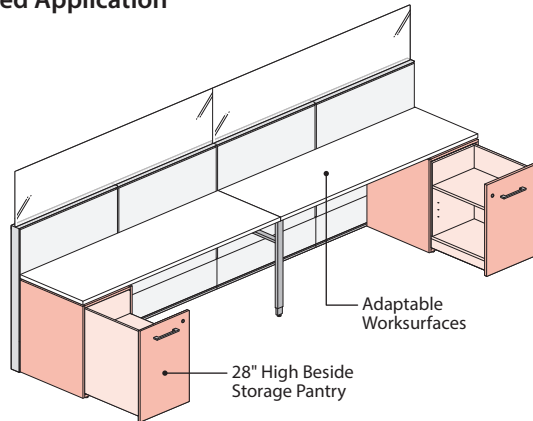

Double Sided Application

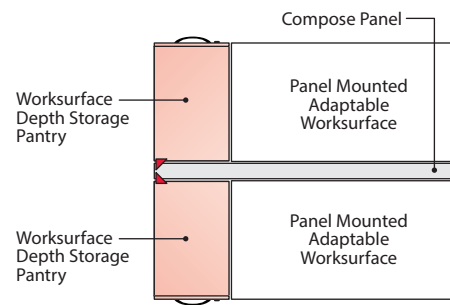
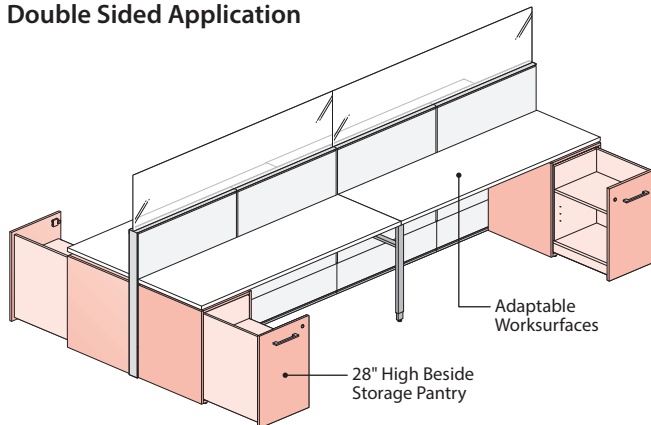

Non-Panel Based – Freestanding Application

28" high Storage Pantry is for use with an Adaptable Convergent worksurface..

Freestanding (Non-Panel Based)

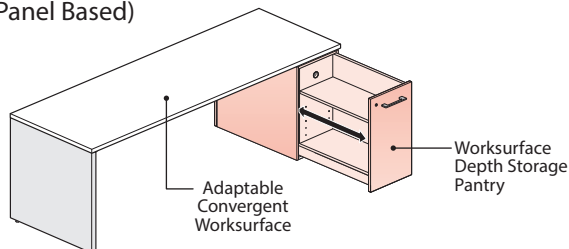

Freestanding (Non-Panel Based)

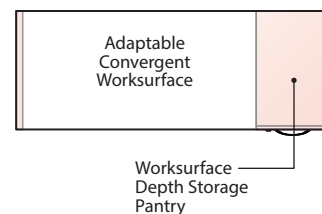

Product Application – Beside Storage

Planning Model Overview – Storage Pantry – 40" and 48" High/Worksurface Depth

40" and 48" high worksurface depth storage pantries are for use adjacent to an Adaptable worksurface or a desking worktop.

Compose Panel Based Applications

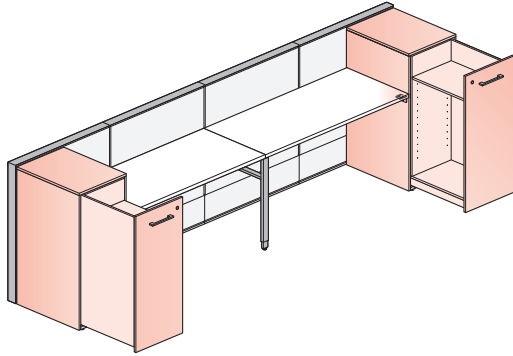

- 40" High Storage pantry is intended for use with 42" high or higher Compose Panels.
- 48" high Storage pantry is intended for use with 50" high or higher Compose Panels.

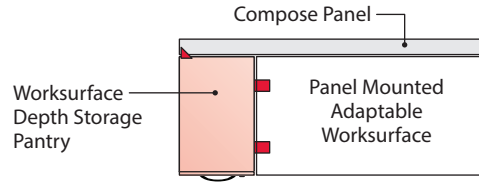

- 12", 15" or 18" wide Worksurface Depth Storage Pantry with panel to pantry bracket and worksurface attachment brackets

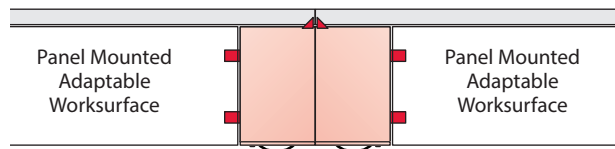

- 12", 15" or 18" wide Worksurface Depth Storage Pantries with panel to pantry brackets and worksurface attachment brackets

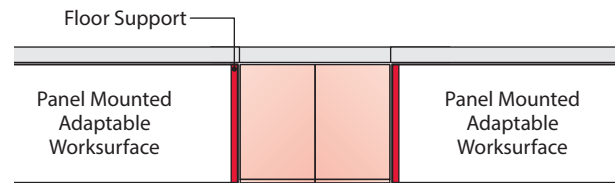

- 15" or 18" wide Worksurface Depth Freestanding Storage Pantries
- 12" wide Worksurface Depth Storage pantry must be panel attached or ganged

Product Application – Beside Storage

Planning Model Overview – Storage Pantry – 40" and 48" High/Worksurface Depth

40" and 48" high worksurface depth storage pantries are for use adjacent to an Adaptable worksurface or a desking worktop.

Desking/Benching Applications

Reside Desking with Legs Adjacent to Storage Pantry

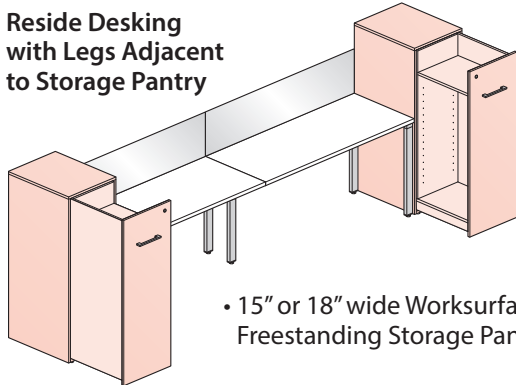

- 15" or 18" wide Worksurface Depth Freestanding Storage Pantry



- 15" or 18" wide Worksurface Depth Freestanding Storage Pantry

Reside Desking without Legs Adjacent to Storage Pantry

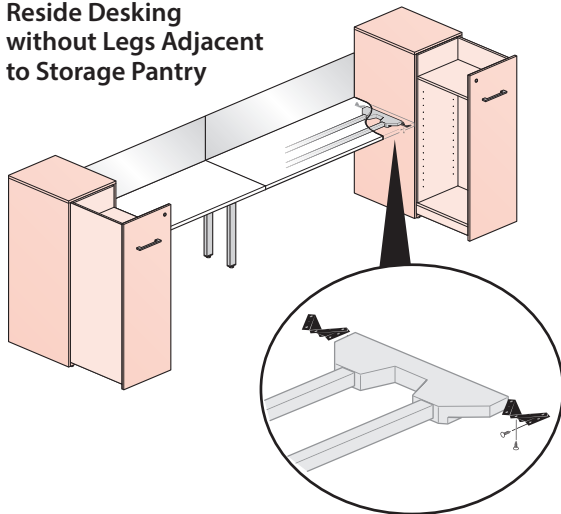

- 12", 15" or 18" wide Worksurface Depth Attached Storage Pantry



- 15" or 18" wide Worksurface Depth Freestanding Storage Pantry

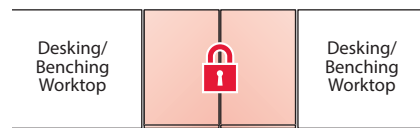

- 12" wide Worksurface Depth Storage Pantries ganged together

Intuity Benching with Legs Adjacent to Storage Pantry

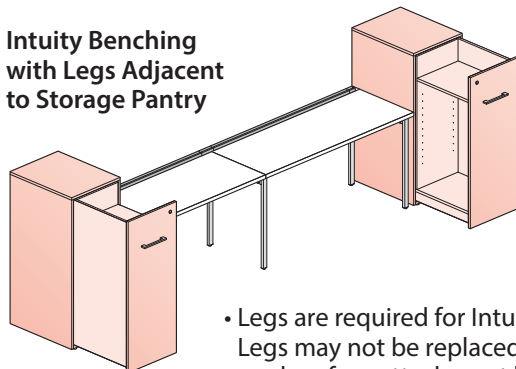

- Legs are required for Intuity benching. Legs may not be replaced with worksurface attachment brackets.

Product Application – Beside Storage

Planning Model Overview – Storage Pantry – 40" and 48" High/Worksurface Depth

40" and 48" high worksurface depth storage pantries are for use adjacent to an Adaptable worksurface or a desking worktop.

Panel Based Applications – Double Sided

Compose Panels

- 40" High Storage pantry is intended for use with 42" high or higher Compose Panels.
- 48" high Storage pantry is intended for use with 50" high or higher Compose Panels.

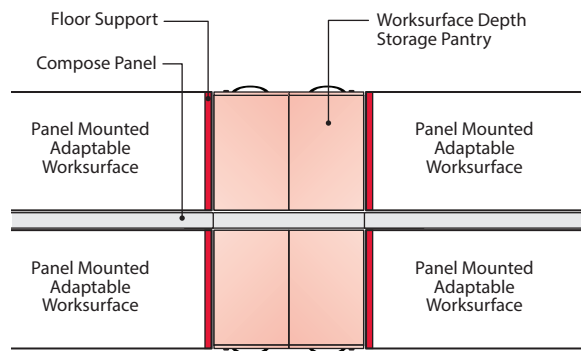
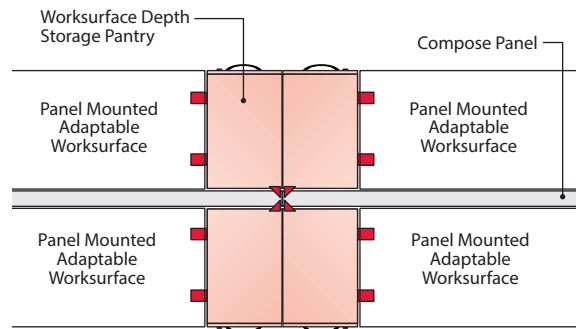
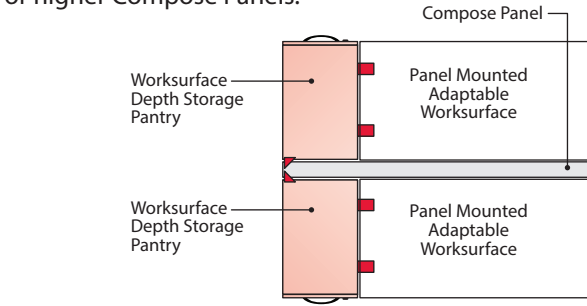
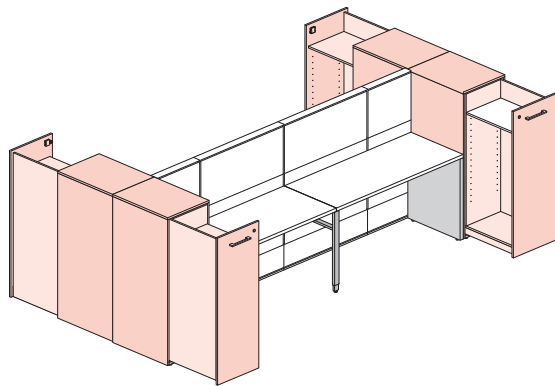
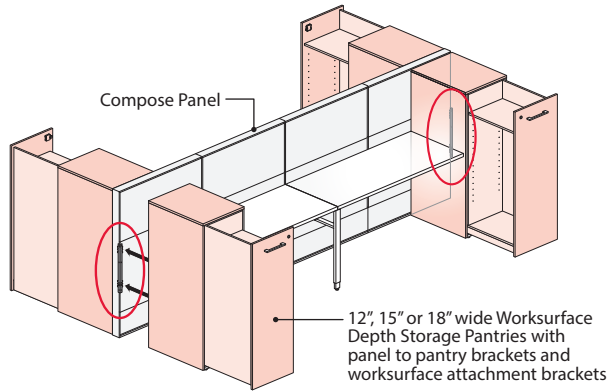

Don't Worksurface depth Storage Pantries are not for use in a double sided desking/benching application because it creates an open gap between pantries.

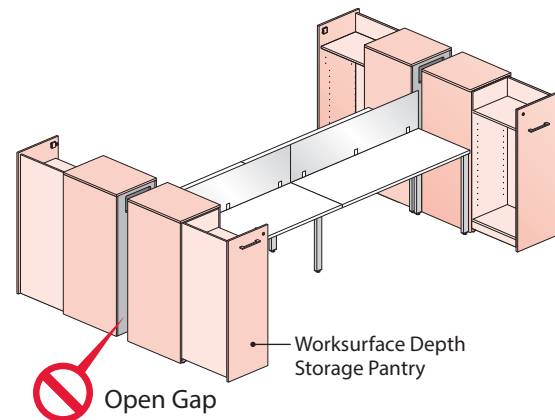

Product Application – Beside Storage

Planning Model Overview – Storage Pantry – 40" and 48" High/Worksurface Depth

Two 40" or 48" high Extended Depth back-to-back storage pantries used at the end-of-run fill the 3" panel gap or desking gap. Extended depth storage pantries are for use in a double sided application, only.

Panel Based Applications – Double Sided

Compose Panels

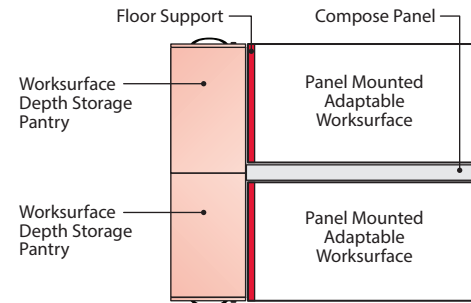
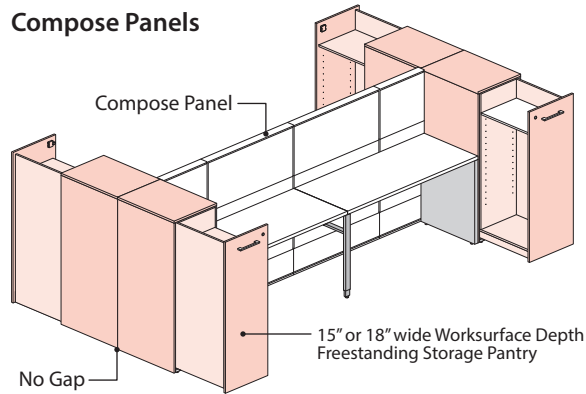

Tip Extended Depth Storage Pantry may not be used with a panel to pantry bracket.

Desking/Benching Applications – Double Sided

Reside Desking

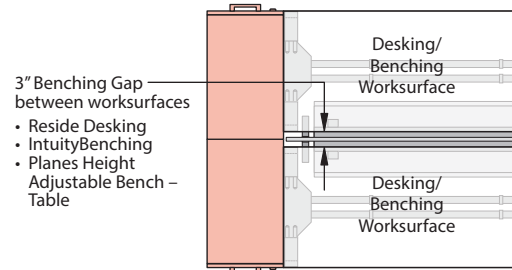
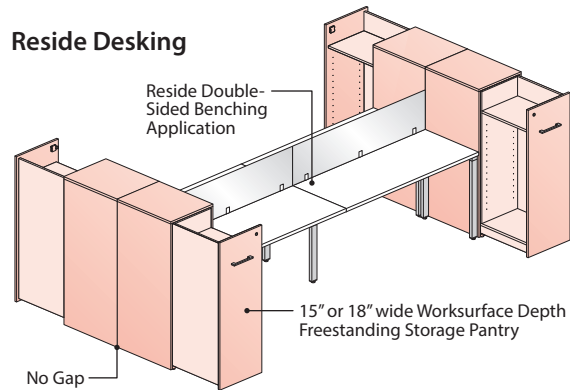

Intuity Benching

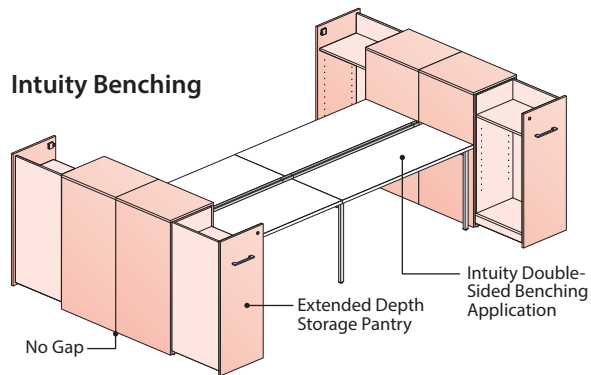

Planes Height Adjustable Bench – Table

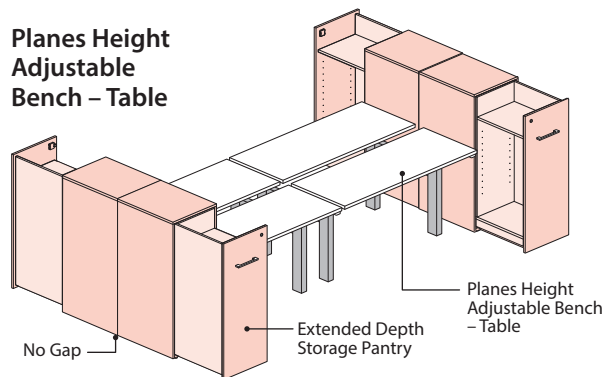

Product Application – Beside Storage

Storage Pantry / Non-Panel Based – Freestanding Applications

Application Guidelines – Storage Pantry (28" High/Worksurface Depth) / Adaptable Convergent Worksurface

Both sides of the convergent worksurface require floor support.

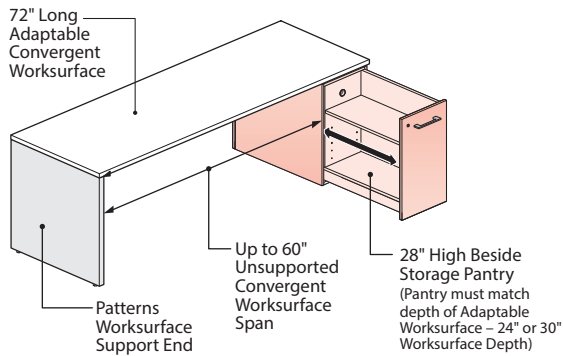

- The 28" high storage pantry includes spacers for attachment below the Adaptable Convergent Worksurface.

Note 60" is the maximum worksurface span allowed between end-of-run floor supports unless an intermediate worksurface floor support is used.

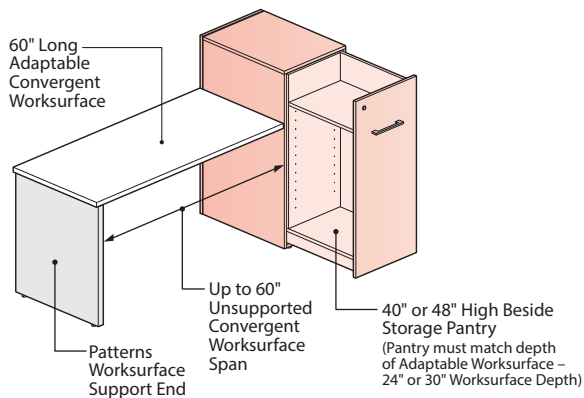

- The 40" and 48" high storage pantry requires separately specified attachment brackets for the Adaptable Convergent Worksurface.

Floor Support Options

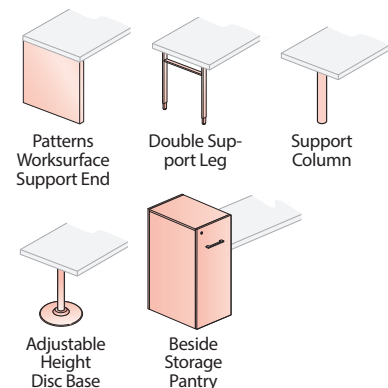

Note Patterns Worksurface Support End is for use with edgeband worksurface trim option, only.

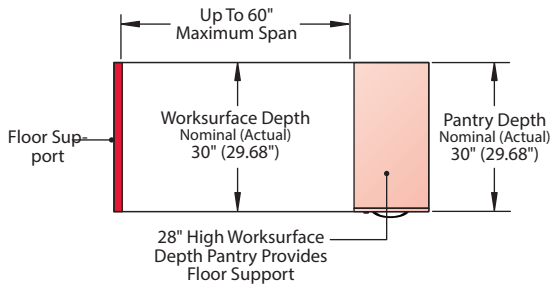
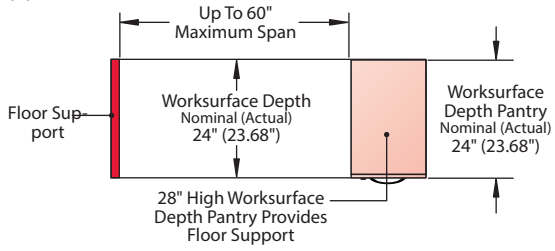

- The 28" high storage pantry includes spacers for attachment below the Adaptable Convergent Worksurface.

Note 60" is the maximum worksurface span allowed between end-of-run floor supports unless an intermediate worksurface floor support is used.

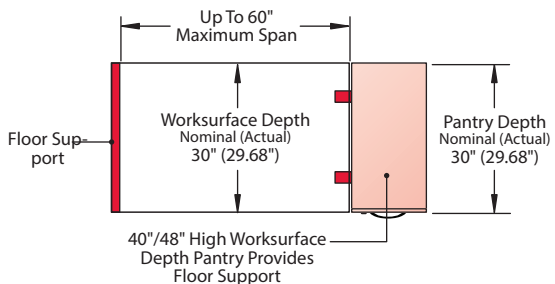
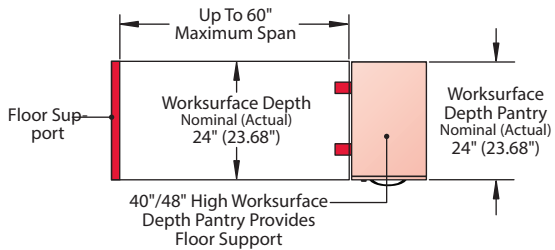

- The 40" and 48" high storage pantry requires separately specified attachment brackets for the Adaptable Convergent Worksurface.

Product Application – Beside Storage

Storage Pantry / Non-Panel Based – Freestanding Applications

Application Guidelines – Storage Pantry (28" High/Worksurface Depth) / Adaptable Convergent Worksurface – Attachment Brackets and Reinforcement Channel

Attachment Bracket / Hardware

- The 28" high storage pantry includes spacers for attachment to the Adaptable Convergent worksurface. No additional worksurface attachment hardware is required.
- The 40" and 48" high storage pantry requires separately specified worksurface attachment brackets.

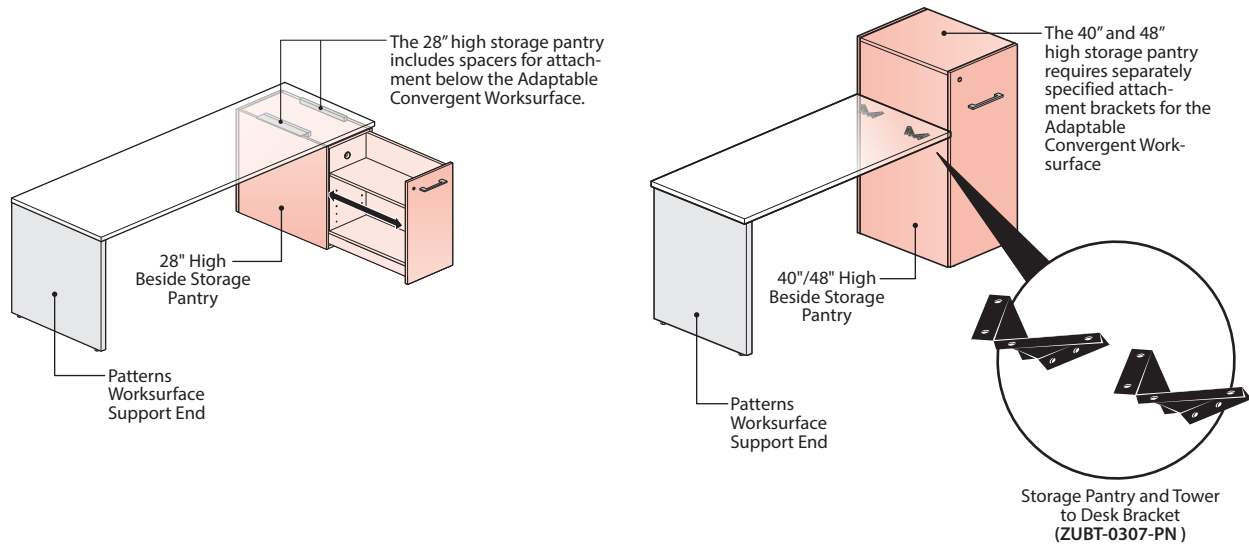

Reinforcement Channel – Guidelines for Convergent Worksurface Spans

- 60" is the maximum worksurface span allowed between worksurface supports.
- A separately specified Worksurface Reinforcement Channel must be specified to provide additional support for laminate or wood worksurfaces with 50" or larger spans that are heavily loaded and not otherwise supported by an intermediate worksurface floor support

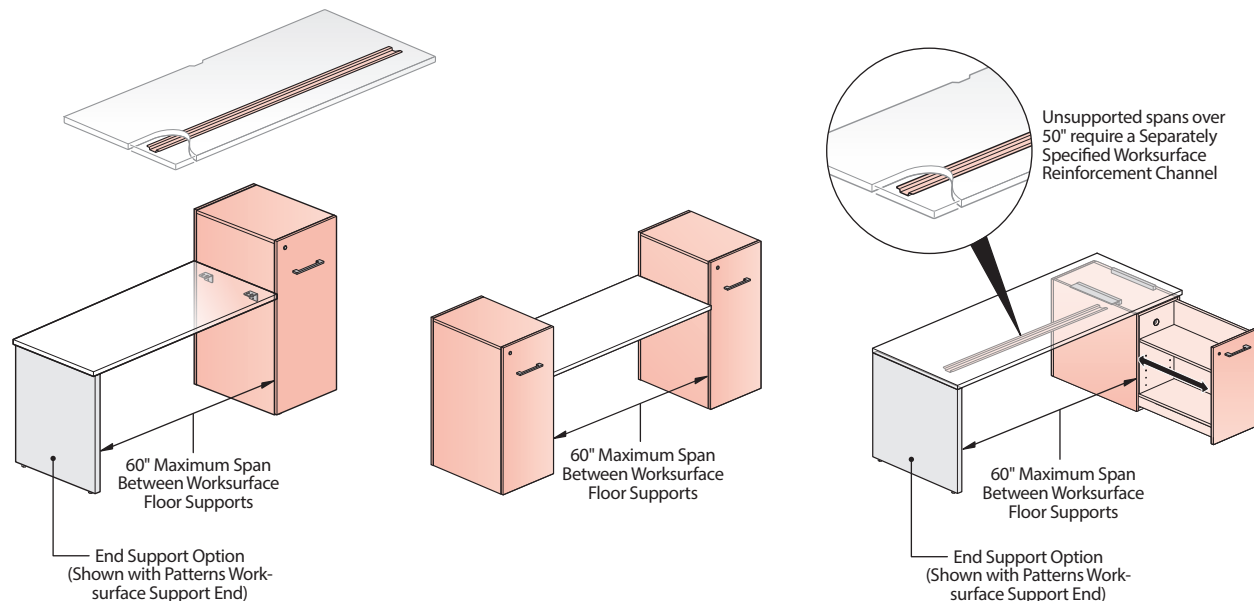

Product Application – Beside Storage

Storage Pantry / Non-Panel Based – Freestanding Applications

Application Guidelines – Storage Pantry (28" High/Worksurface Depth) / Adaptable Convergent Worksurface – Finished Back

- A finished back panel may be separately specified as needed.
- If the back of the storage pantry is exposed a finished back is required.
- Adds $\frac{3}{4}$ " to the depth of the Storage pantry.
- Once installed the finished back is not removable.
- Does not interfere with the spacer used to attach the worksurface in 28" high storage pantry application.

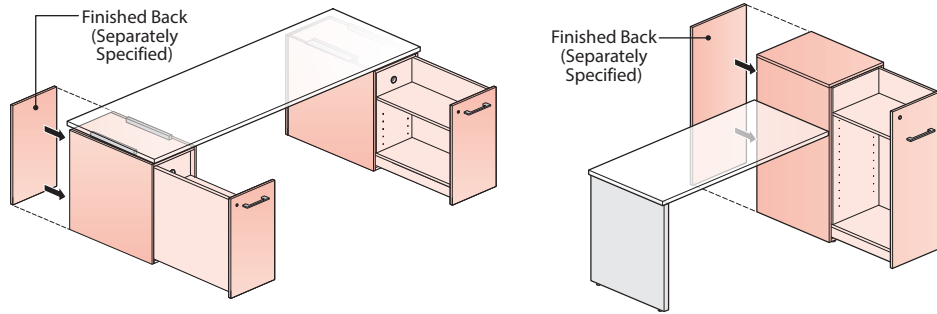

- A Finished Back is for use in a single sided application when the back of the storage pantry is visible.

Product Application – Beside Storage

Storage Pantry / Non-Panel Based – Freestanding Applications

Application Guidelines – Storage Pantry (28" High/Worksurface Depth) / Adaptable Convergent Worksurface
 Worksurface Depth Pantry – Adaptable Convergent Worksurface – Finished Backs

 **Do** • Storage Pantries are for use with an Adaptable Convergent worksurface.

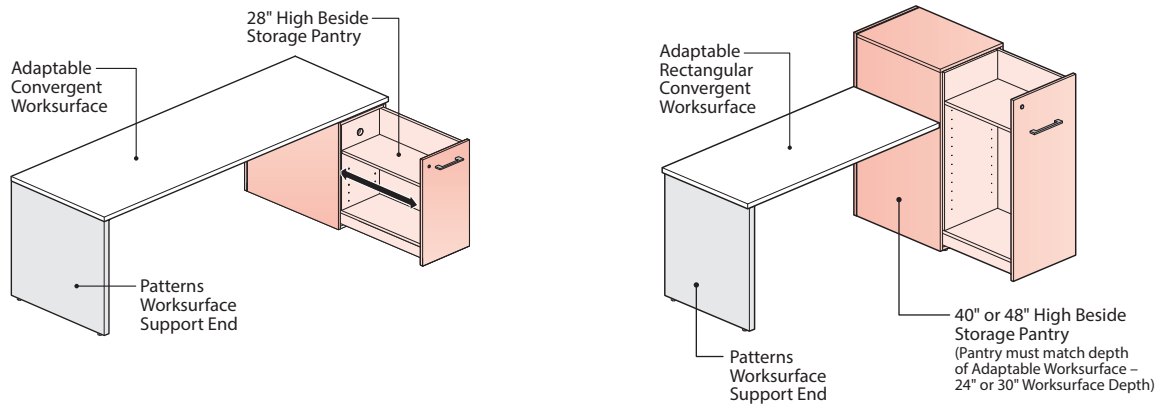

Application Guidelines – Storage Pantry (28" High – Worksurface Depth) / Freestanding – Non-Panel Based

 **Don't** • 28" high Storage Pantry is not for use in the following applications.

Freestanding

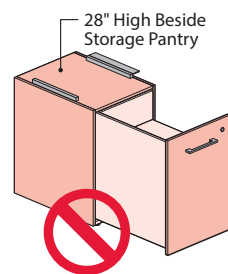

Planes Height Adjustable Table

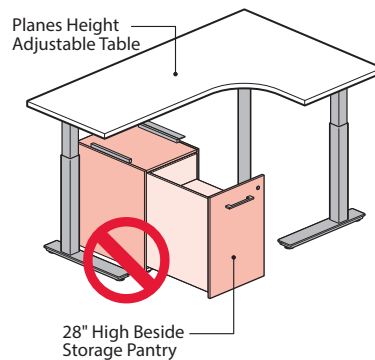

Planes Height Adjustable Table – Bench

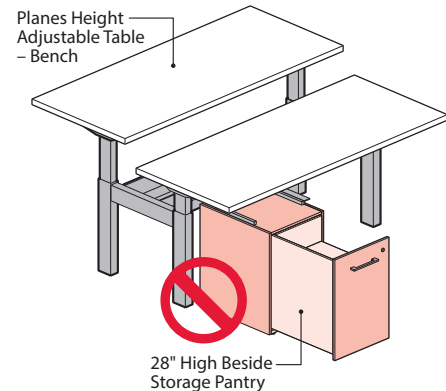

Intuity Benching

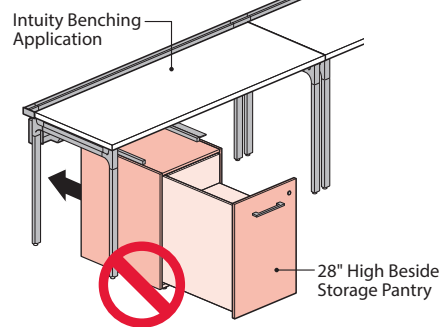

Reside Desking

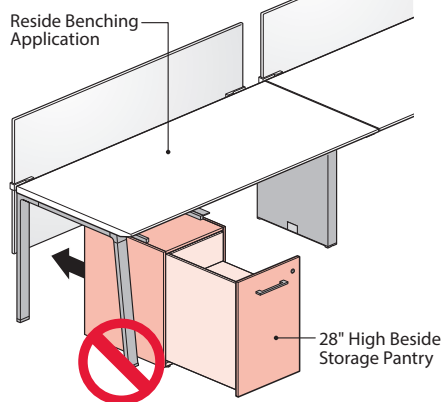

28" High Storage Pantry:

- Not for use as a freestanding unit.
- May not be attached to a height adjustable worktop.
- Not for use with Intuity Benching or Reside Desking product lines; interferes with the understructure.

Product Application – Beside Storage Pantry

Storage Pantry / Compose Panel Applications

Basic Guidelines – Storage Pantry (28" High/Worksurface Depth) / Compose Panel

- 28" high Beside Storage Pantry is designed for applications using Compose Panels and Adaptable Worksurfaces.
- 28" high Beside Storage Pantry is not for use with Reside, Intuity, Planes or any other product platforms.
- The Adaptable Worksurface and the 28" high Beside Storage Pantry must be the same depth.

Single Sided Compose Panel Application

- Worksurface Depth Storage Pantry
- Adaptable Worksurfaces

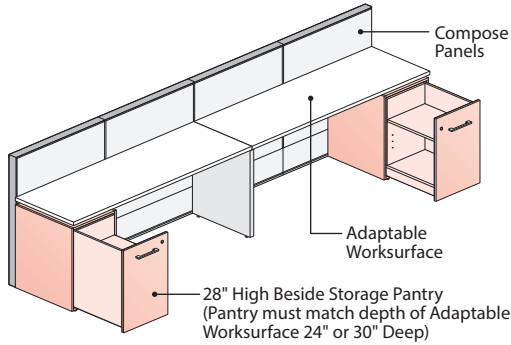

Double Sided Compose Panel Application

- Worksurface Depth Storage Pantry
- Adaptable Worksurfaces

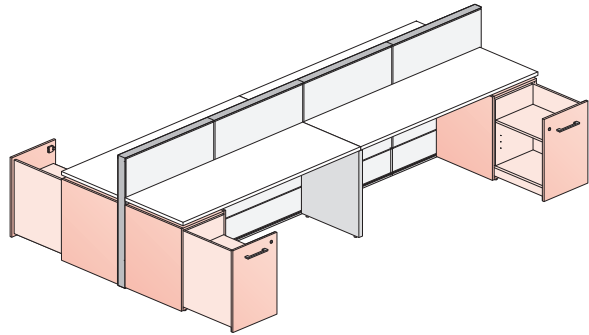

- Note**
- 28"H Beside Storage Pantry is standard worksurface depth only; not available in extended depth.
 - 28"H Beside Storage Pantry is not for use with Overhead Storage Units.

Basic Guidelines – Storage Pantry (40" and 48" High – Worksurface Depth) / Compose Panel

- The 40" and 48" high/worksurface Depth Beside Storage Pantry is designed for applications using Compose Panels and Adaptable Worksurfaces.
- The 40" high Beside Storage Pantry is intended for use with 42" or higher Compose Panels.
- The 48" high Beside Storage Pantry is intended for use with 50" or higher Compose Panels.
- The depth of the Adaptable Worksurface must not be more than the Beside Storage Pantry depth.

Single Sided Applications

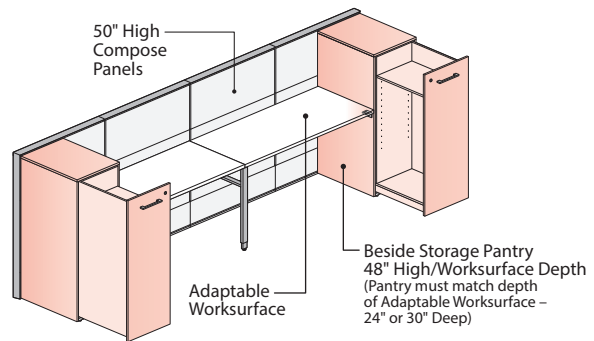
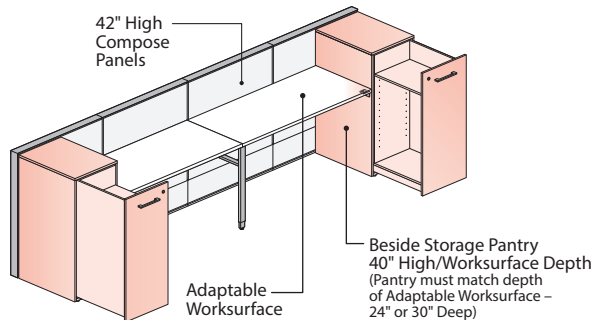

Double Sided Applications

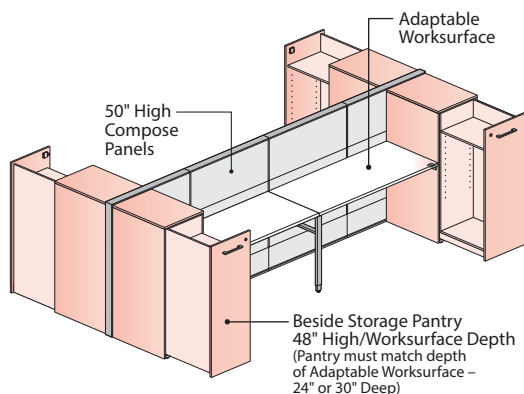
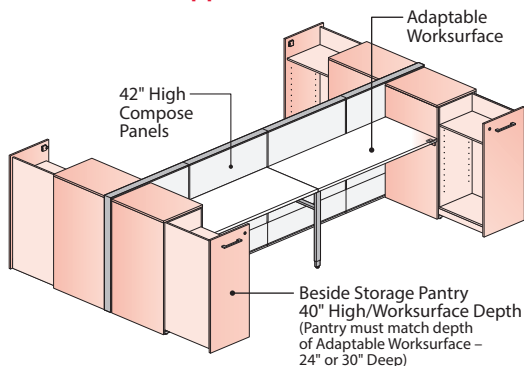

Product Application – Beside Storage Pantry

Storage Pantry / Compose Panel Applications

Support and Load Guidelines

Basic Guidelines for Beside Storage Pantry Applications with Compose Panels and Adaptable Worksurfaces

- ✓ A panel run must have floor support at each end.
- ✓ A Panel Run with components requires floor support every 10' per loaded side.

Note • Refer to Support and Load section for application details and exceptions to basic planning guidelines.

Group B Floor Support

- A Worksurface Depth Beside Storage Pantry may be used with a separately specified Compose Panel to Pantry Bracket (ZZBF-1800-PNW) to provide Group B floor support for Compose panels.
- Group B floor support is for use without panel mounted overhead storage only.

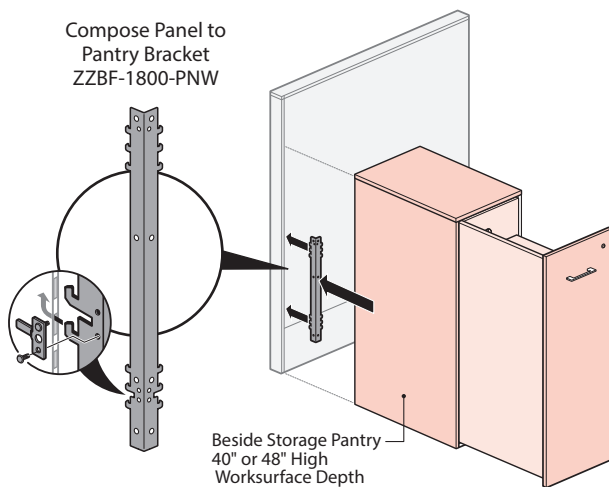
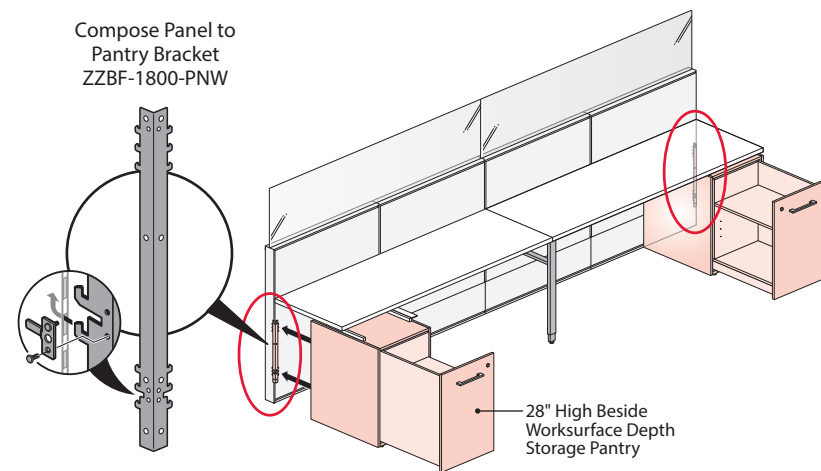

Product Application – Beside Storage

Storage Pantry / Compose Panel Applications

Basic Guidelines – Storage Pantry (28" High/Worksurface Depth) / Compose Panel – Attachment Brackets

In the applications below the Worksurface Depth Storage Pantry is providing panel support with the separately specified panel to storage attachment brackets. The 28" high storage pantry must be the same depth as the Adaptable worksurface.

Single Sided / Unbalanced Compose Panel-Application

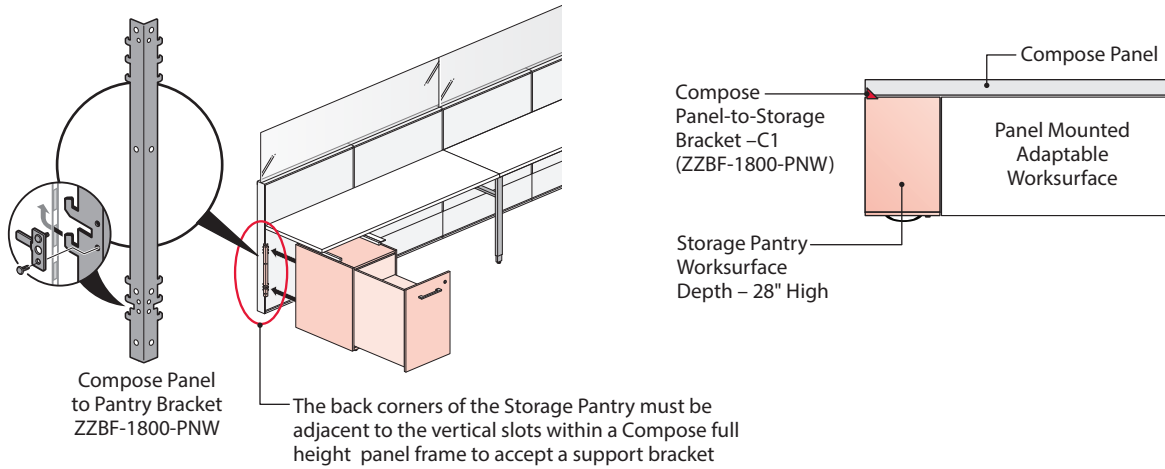

Double Sided / Balanced Compose Panel-Application

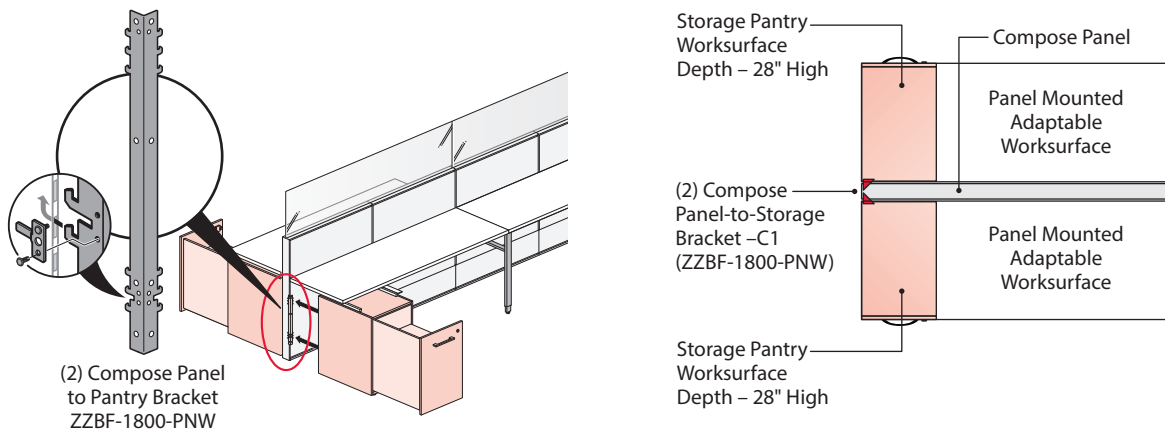

Attachment Bracket / Hardware

- The 28" high storage pantry includes spacers for attachment to the Adaptable worksurface.
- Additional attachment bracket (ZZBF-1800-PNW) is required for panel support.
- Attachment bracket (ZZBF-1800-PNW) is non-handed and requires field drilling of the storage pantry.

Note

- A panel run must have floor support at each end. Refer to the Compose Specification Guide for application specific Support and Load guidelines.
- Attachment bracket (ZZBF-1800-PNW) is not for use with a Compose Connections panel.

Don't

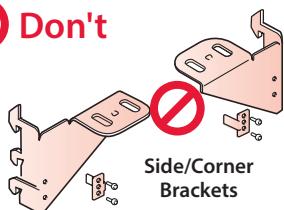

- Do not use Side/Corner Brackets instead of a Compose Panel-to-Storage Bracket -C1 (ZZBF-1800-PNW)
- Side/Corner Brackets are not for use with 28" high storage pantry.

Product Application – Beside Storage

Storage Pantry / Compose Panel Applications

Application Guidelines – Storage Pantry (40" and 48" High/Worksurface Depth) / Compose Panel

In the Compose Panel System applications below the Worksurface Depth Storage Pantry is attached to the panel for the required panel support.

Single Sided / Compose Panel System Applications

Same Nominal Depth Beside Storage Pantry and Adaptable Worksurface is recommended.

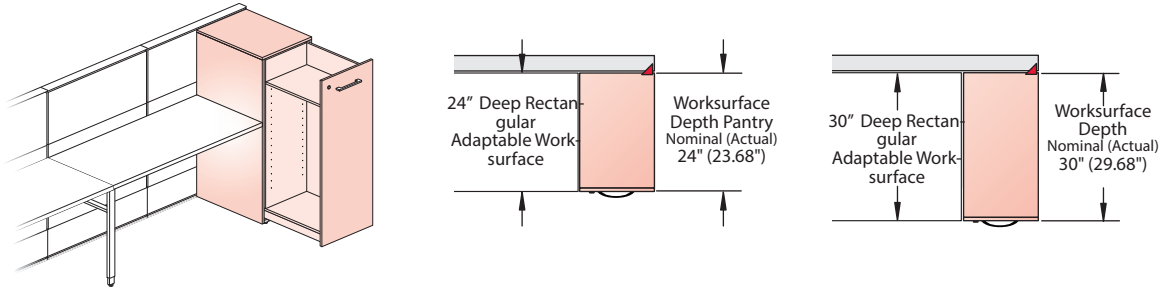

A deeper Beside Storage Pantry adjacent to a shallower depth Adaptable Worksurface may be used but is not recommended for aesthetic reasons.



Don't A deeper Beside Storage Pantry adjacent to a shallower depth Adaptable Worksurface may be used but is not recommended for aesthetic reasons.



Double Sided / Reside Benching Applications

Don't Back to Back Worksurface Depth Storage Pantries are not for use in a Double Sided Compose Panel Application.

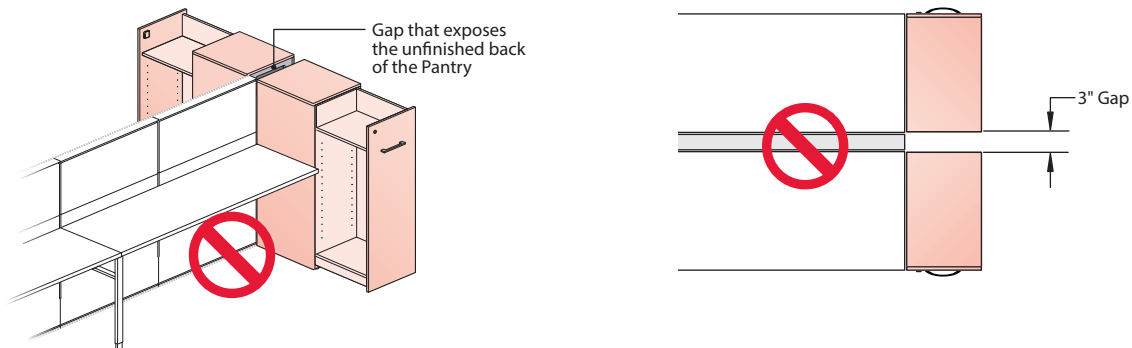

Product Application – Beside Storage

Storage Pantry / Compose Panel Applications

Application Guidelines – Storage Pantry (40" and 48" High/Worksurface Depth) / Compose Panel – Attachment Brackets

In the applications below the end of the Worksurface is off-module to the full panel frame. The off-modular condition does not allow for use of a panel mounted worksurface support. The (ZUBW-0000-PN) bracket attaches the worksurface to the storage pantry. The worksurface end adjacent to the storage pantry requires (2) separately specified (ZUBW-0000-PN) brackets. The Compose Panel-to-Storage Bracket C1 attaches the storage pantry to the panel.

40" or 48" high Worksurface Depth Pantry provides floor support with separately specified brackets.

Single Sided / Unbalanced Compose Panel-Application

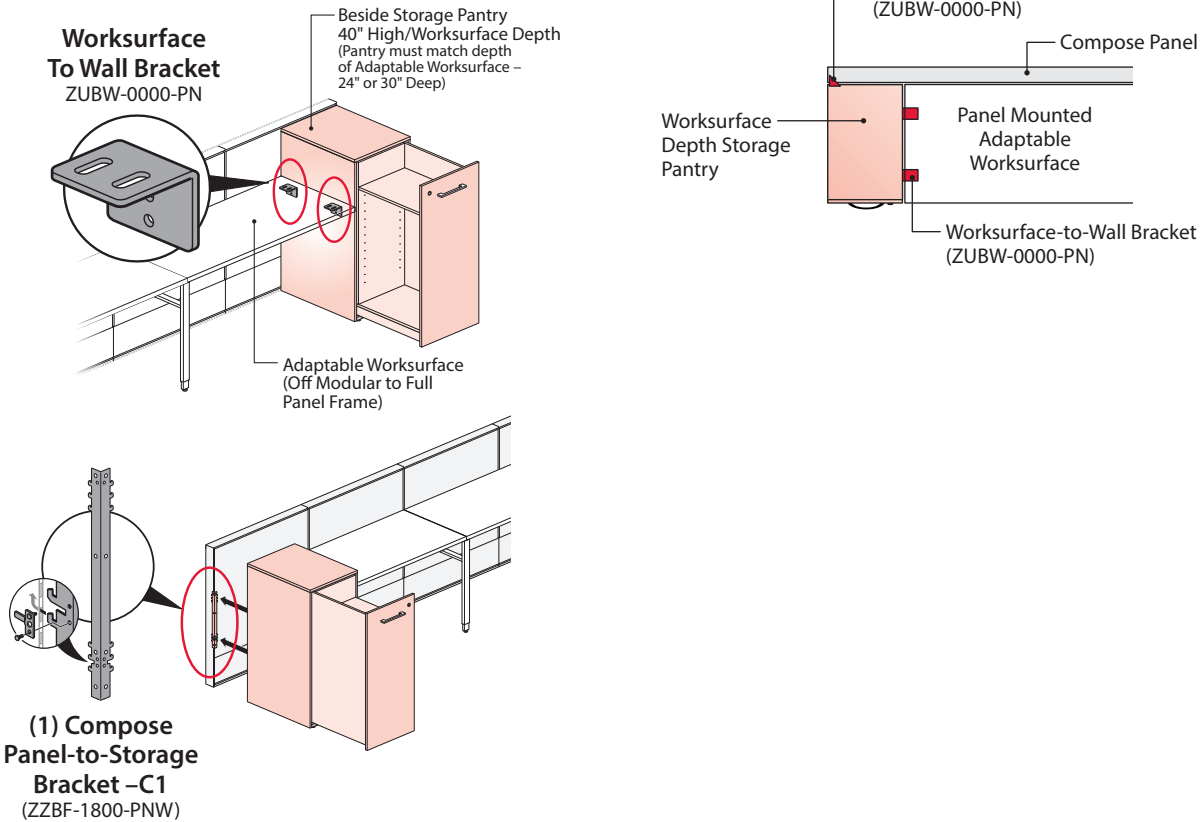

Double Sided / Balanced Compose Panel-Application

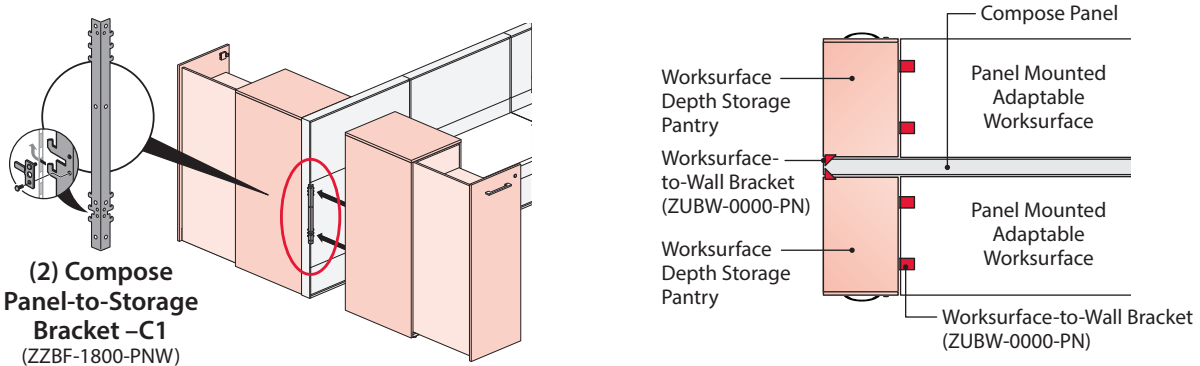

- Note**
- A panel run must have floor support at each end. Refer to the Compose Specification Guide for application specific Support and Load Guidelines.
 - Attachment bracket (ZZBF-1800-PNW) is not for use with a Compose Connections panel.

Product Application – Beside Storage

Storage Pantry / Compose Panel Applications

Application Guidelines – Storage Pantry (Worksurface Depth) / Compose Panel – Worksurface Support and Load – Reinforcement Channel and Reinforcement Bar

The panel and worksurface require separately specified support per application. Refer to the Compose Specification Guide for application specific Support and Load guidelines.

Worksurface Reinforcement Channel

- Worksurface reinforcement channels must be specified to provide additional support for laminate or wood worksurfaces with 50" or larger spans that are heavily loaded and not otherwise supported by mid-span cantilevers, worksurface supports, legs, or under-worksurface storage.

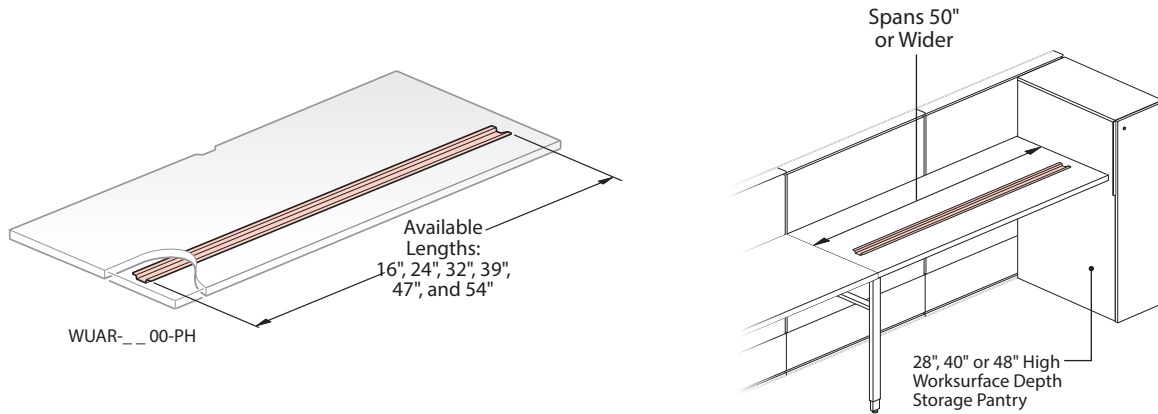

Note A panel run must have floor support at each end. Refer to the Compose Specification Guide for application specific Support and Load Guidelines.

Worksurface Reinforcement Bar

- When the height of the spine panel is 50" or lower; A minimum of 72" worksurface reinforcement bar must be specified to provide additional support on a contiguous laminate or wood worksurface with 72" or greater gap between floor supports. Where feasible; longer worksurface reinforcement bars provide additional strength.
- A 72" worksurface span without front edge support requires a Reinforcement Bar.

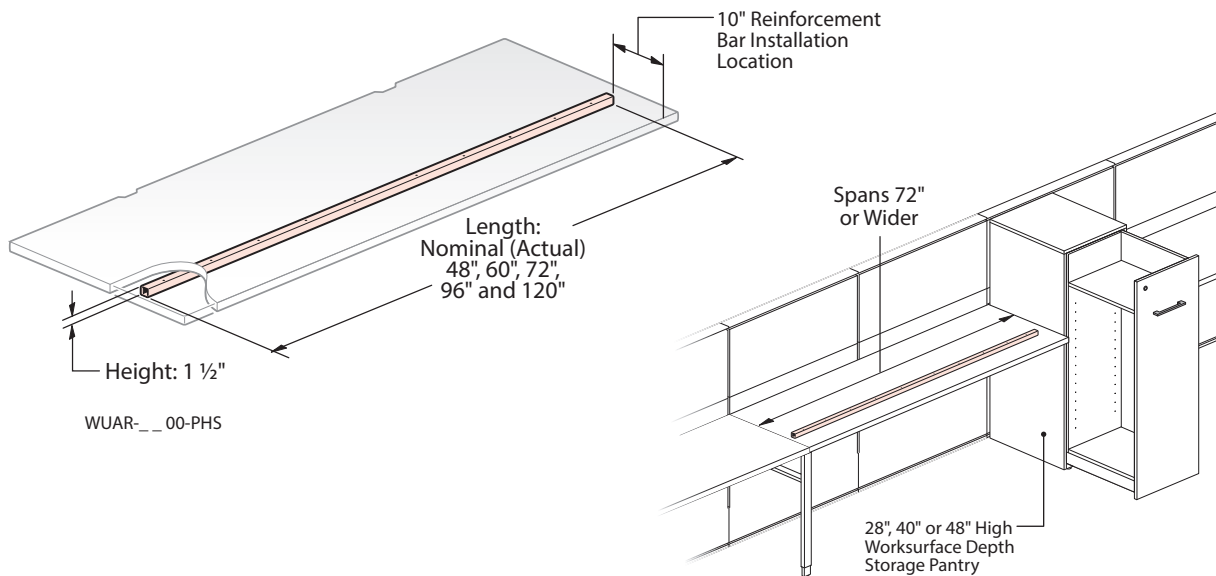

Note • The panel and worksurface require separately specified support per application. Refer to the Compose Specification Guide for application specific Support and Load guidelines.

Product Application – Beside Storage

Storage Pantry / Compose Panel Applications

Application Guidelines – Storage Pantry (40" and 48" High/Worksurface Depth) / Compose Panel – Finished Backs

- A Finished Back may not be used in applications where a worksurface depth Storage Pantry attached to a Compose Panel using the Compose Panel to Pantry Bracket (ZZBF-1800-PNW).
- A Storage Pantry with an unfinished back requires a Compose Panel of the same height or taller to cover the unfinished back.
- Applications where the Compose Panel is shorter than the Beside Storage Pantry should be avoided since the unfinished back of the Storage Pantry will be visible.

Single Sided / Unbalanced Compose Panel-Application

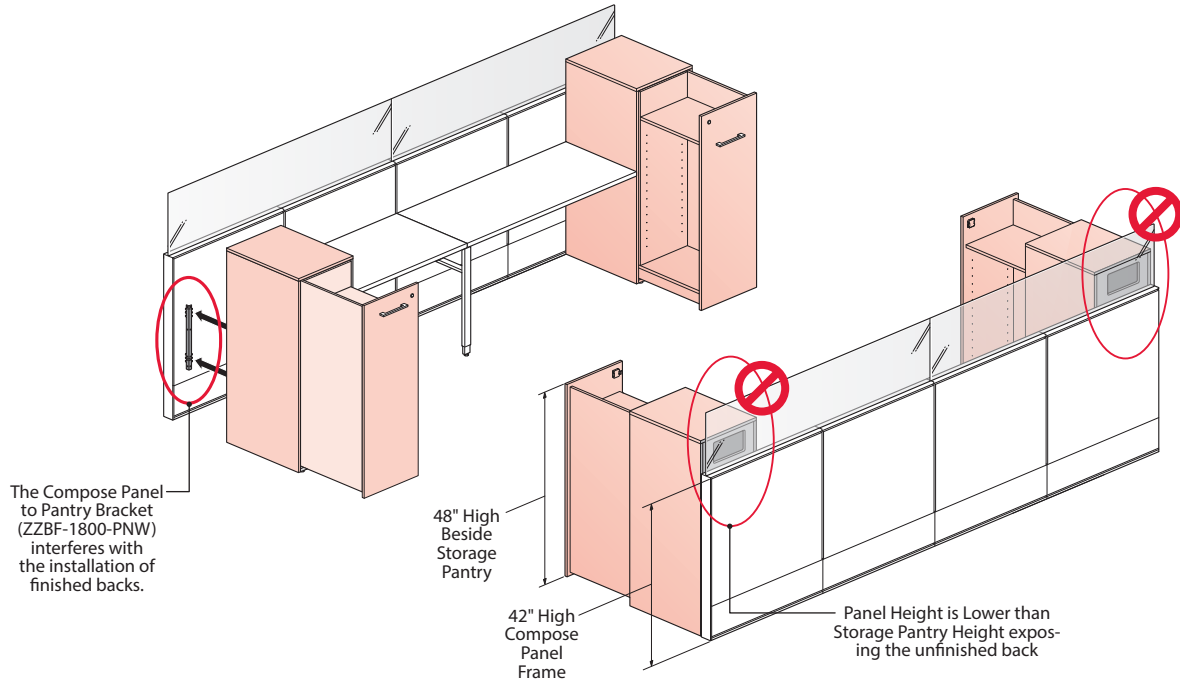

Don't

Don't specify the panel height lower than the Beside Storage Pantry. A finished back may not be used with a Compose Panel to Pantry Bracket (ZZBW-1800-PNW). Using a lower panel results in a Storage Pantry with visibly exposed unfinished back.

Product Application – Beside Storage

Storage Pantry / Compose Panel Applications

Application Guidelines – Storage Pantry (40" and 48" High/Worksurface Depth) / Compose Panel

- The Extended Depth Storage Pantry is 1.5" deeper than the Worksurface Depth Storage Pantry.
- Extended Depth Storage Pantries are to be used in a back-to-back condition.
- The overall depth of the Pantries fill the 3" panel gap at the end-of-run.

In the Compose Panel application below the Extended Depth Storage Pantries are freestanding. Storage Pantry must be 15" or 18" wide. A 12" wide storage pantry may not be freestanding.

Double Sided Compose Panel Applications

- 40 or 48" high Freestanding Extended Depth Storage Pantry
- 15" or 18" wide Storage Pantries, only

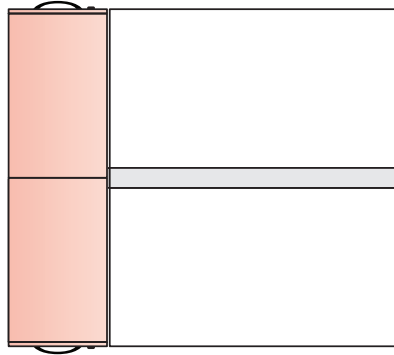

Compose Panel-to-Storage Bracket – C1

The Compose Panel-to-Storage Bracket – C1 (ZZBF-1800-PNW) is not for use with an Extended Depth Pantry. The increased depth of the extended depth pantry does not allow for a ZZBF-1800-PNW to attach to a Compose Panel.

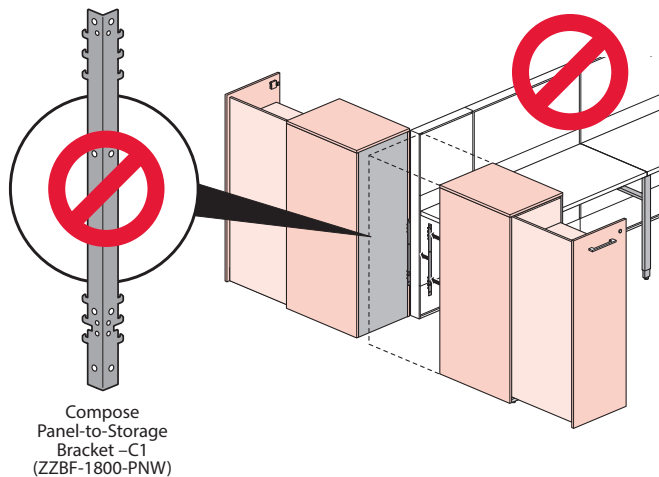

Note • Refer to the Compose System Specification Guide for additional panel application guidelines.

Product Application – Beside Storage

Storage Pantry / Compose Panel Applications

Application Guidelines – Storage Pantry (40" and 48" High/Worksurface Depth) / Compose Panel

- In the Compose Panel applications below the Extended Depth Storage Pantry is freestanding.
- Storage Pantry must be 15" or 18" wide. A 12" wide storage pantry may not be freestanding.

Double Sided / Reside Benching Applications

- Same Nominal Depth Beside Storage Pantry and Adaptable Worksurface is recommended.

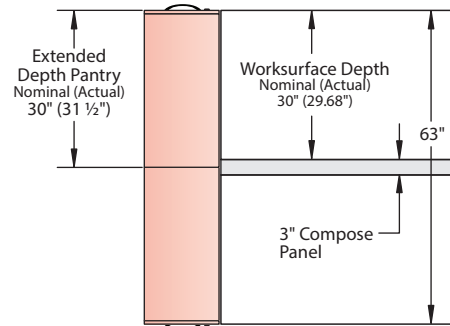
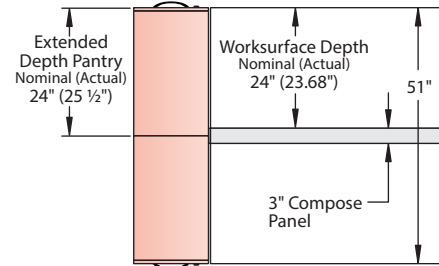
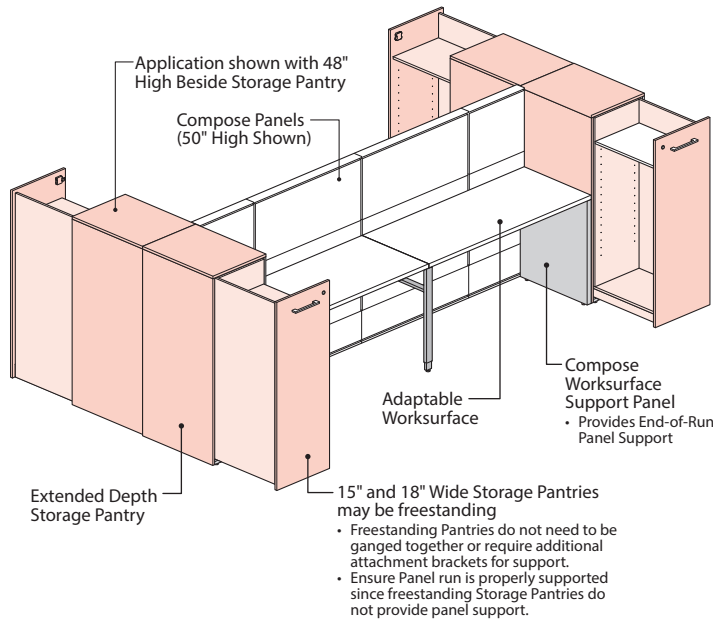

A deeper Beside Storage Pantry adjacent to a shallower depth Adaptable Worksurface may be used but is not recommended for aesthetic reasons.

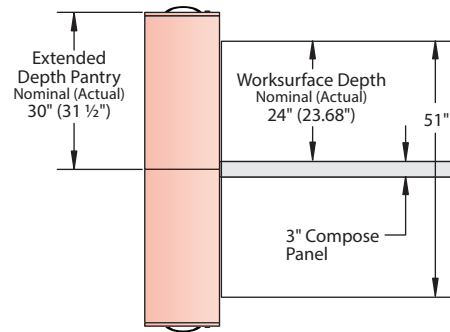
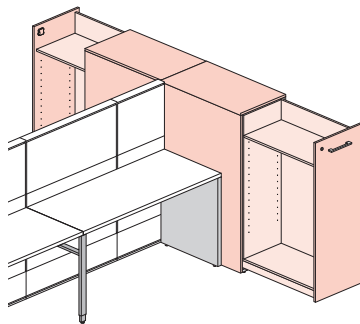

Don't A deeper Beside Storage Pantry adjacent to a shallower depth Adaptable Worksurface may be used but is not recommended for aesthetic reasons.

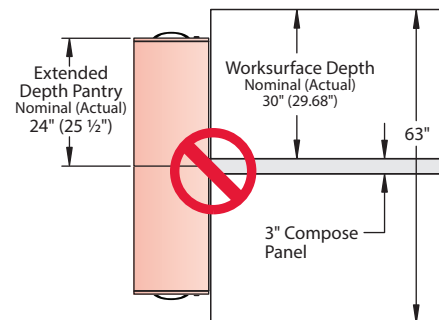
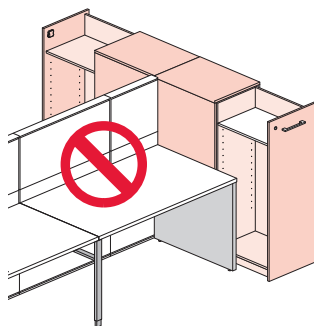

Product Application – Beside Storage Pantry

Storage Pantry / Compose Panel Applications

Application Guidelines – Storage Pantry (40" and 48" High/Worksurface Depth) / Compose Panel

- 15" and 18" Wide Beside Storage Pantries may be freestanding. They do not require ganging or attachment brackets when used in applications adjacent to Compose Panels.
- 12" Wide Beside Storage Pantries may not be freestanding and must be ganged side to side.
- Extended Depth Beside Storage Pantry are designed to be used in conjunction with Compose Panel Runs, but since the Storage Pantry is not attached to the Panel it provides no panel support. Ensure all panels have necessary panel support.

✓ Do

- Applications with freestanding Extended Depth Pantries do not provide panel floor support, ensure adjacent panels include required floor support.
- In the application below (4) Worksurface Support Panels and (4) Anti-Dislodgement Brackets provide support at each end of the panel run. The (2) P-Leg's provide intermediate support.

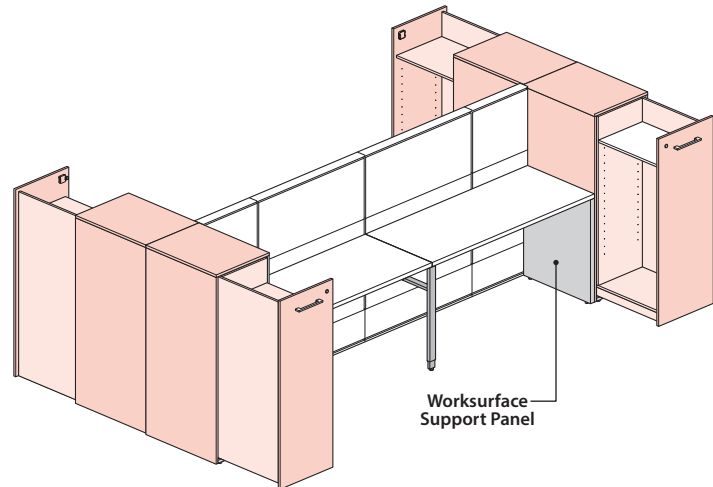

✓ Do

- Worksurface Support Panels (ZZFS-____-LNE_) must be used with a separately specified Adaptable Worksurface and Anti-Dislodgement Bracket (ZZBF-0000-P_).
- Worksurface Support Panel may be 6" less than worksurface depth.

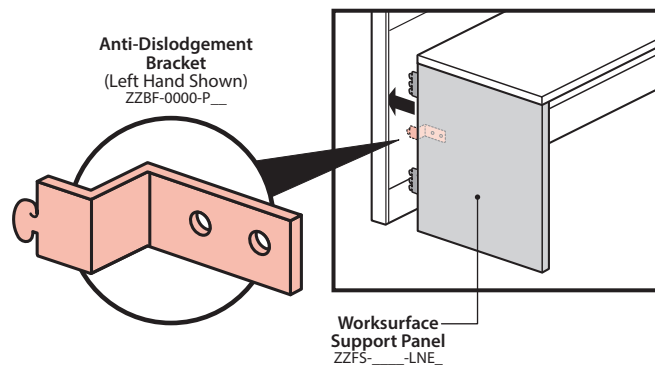

⊘ Don't

- A Compose Panel to Pantry Bracket, (ZZBF-1800-PNW) is not for use with an Extended Depth Pantry.
- The increased depth of the extended depth pantry does not allow for a Compose Panel-to-Storage Bracket to be used.

Top View

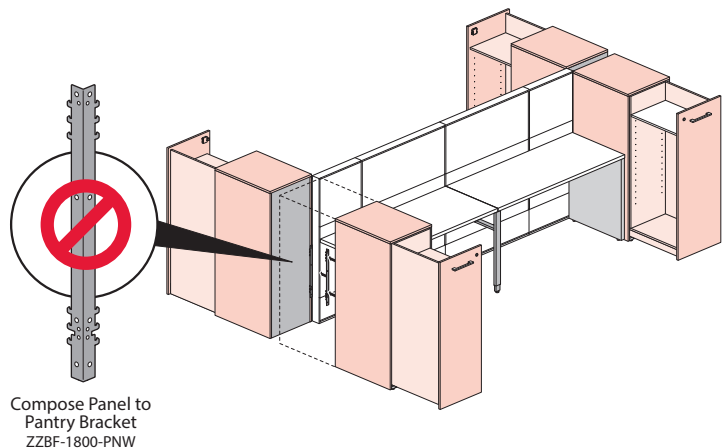
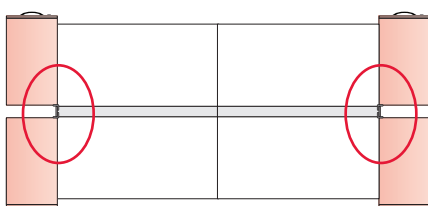

Product Application – Beside Storage

Storage Pantry / Reside Benching Applications

- The Beside Storage Pantry may be used with Reside single or double-sided benching applications.

Basic Guidelines – Storage Pantry (40" and 48" High/Extended Depth) / Reside Benching – Single-Sided

- 24" deep Reside worksurfaces are for use with 24" Deep (Worksurface Depth) Beside Storage Pantries.
- 30" deep Reside worksurfaces are for use with 30" Deep (Worksurface Depth) Beside Storage Pantries.
- 15" and 18" wide Storage Pantry may be freestanding.
- 12" Wide Storage Pantry cannot be freestanding, requires side-to-side ganging.

Note The 28" High Beside Storage Pantry is not for use with Reside worksurfaces due to interference with the worksurface understructure.

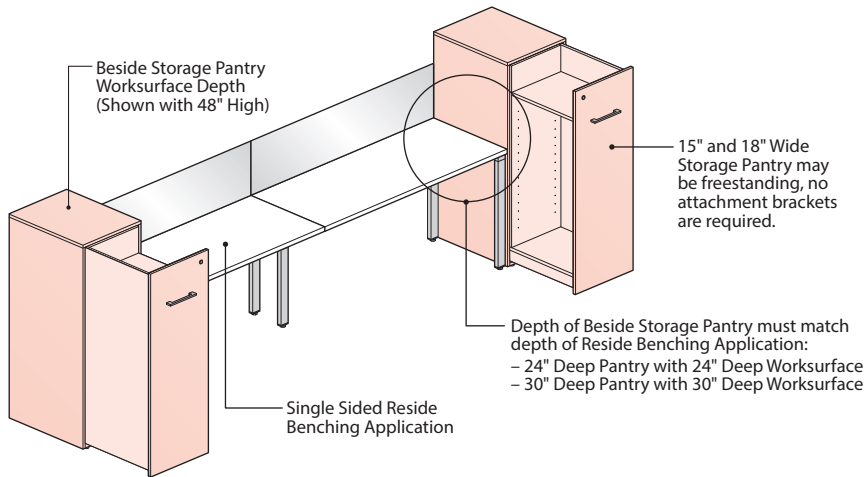

Note If the back of the Storage Pantry is visible a separately specified finished back is required.

Basic Guidelines – Reside Benching / 40" and 48" High Extended Depth Pantry – Double-Sided

- Specify back-to-back 25 1/2" Deep Extended Depth Beside Storage Pantries for applications with double sided 24" Deep Reside Worksurfaces.
- Specify back-to-back 31 1/2" Deep Extended Depth Beside Storage Pantries for applications with double sided 30" Deep Reside Worksurfaces.
- 15" and 18" Wide Storage Pantry may be freestanding.
- 12" Wide Storage Pantry cannot be freestanding, requires side-to-side ganging.

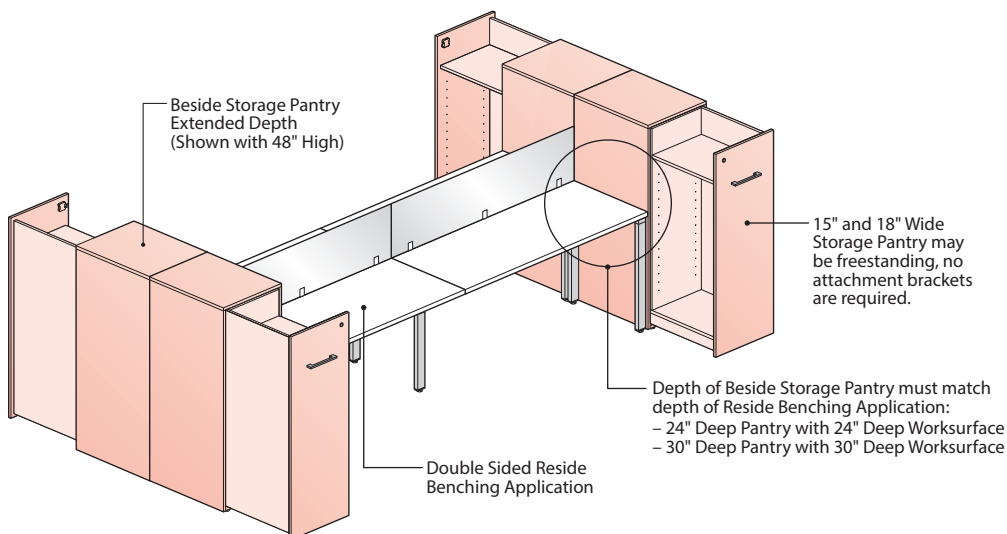

Note 12" wide storage pantry may not be freestanding. Requires (ZKBG-0000-PN) attachment brackets

Product Application – Beside Storage

Storage Pantry / Reside Benching Applications

Basic Guidelines – Storage Pantry (40" and 48" High/Extended Depth) / Reside Benching – Single-Sided

- In the Reside Benching applications below the Worksurface Depth Storage Pantry is freestanding.
- Storage Pantry must be 15" or 18" wide. A 12" wide storage pantry may not be freestanding.

Reside Benching Application – Single Sided – Leg Supported

Same Nominal Depth Beside Storage Pantry and Reside Desking Worksurface is recommended

The front edge of the Storage Pantry aligns with the front edge of the worksurface when both are specified with matching depths.

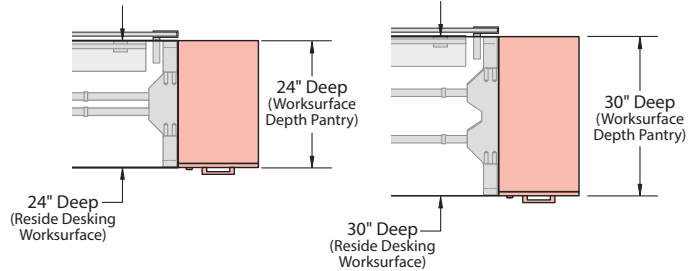
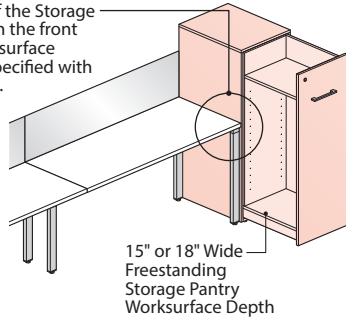

A deeper Beside Storage Pantry adjacent to a shallower depth Reside Desking Worksurface may be used but is not recommended for aesthetic reasons.

The front edge of the Reside Worksurface is inset from the front of the Storage Pantry

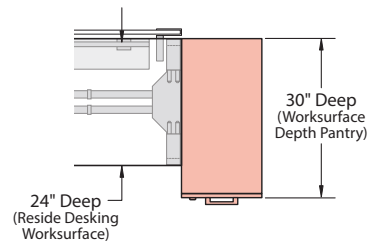
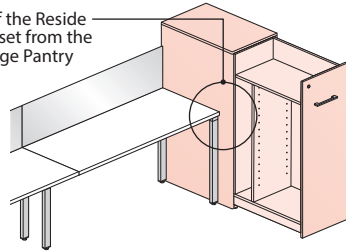

- Don't** • A shallower Beside Storage Pantry adjacent to a deeper Reside Desking Worksurface is not recommended for functional and aesthetic reasons.

The Leg interferes with access to the Storage Pantry

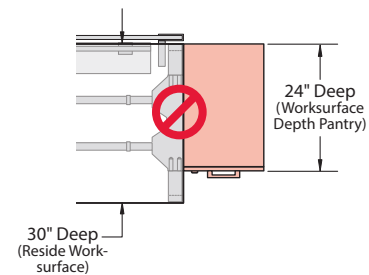
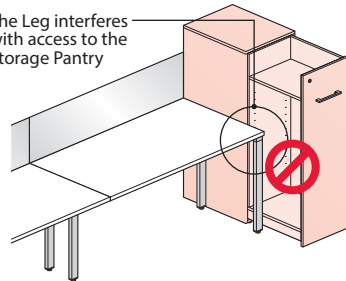

Reside Benching Application – Double Sided – Leg Supported

- Don't** • Back to Back Worksurface Depth Storage Pantries are not for use in a Double Sided Reside Benching Application.

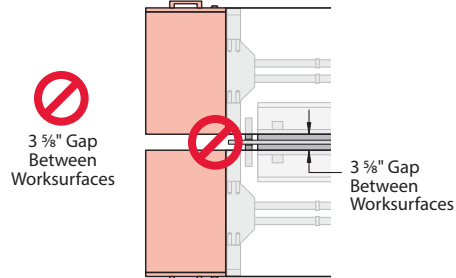
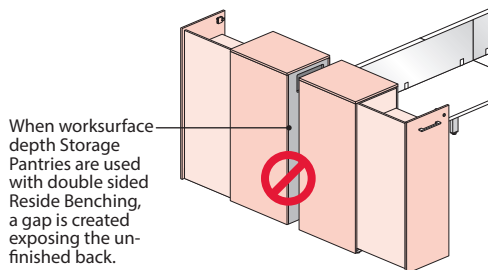

Product Application – Beside Storage

Storage Pantry / Reside Benching Applications

Basic Guidelines –Storage Pantry (40" and 48" High/Extended Depth) / Reside Benching – Single-Sided

- In the Reside Benching applications below the Worksurface Depth Storage Pantry is freestanding.
- Storage Pantry must be 15" or 18" wide. A 12" wide storage pantry may not be freestanding.

Reside Benching Application – Single Sided – Bracket Supported

- Same Nominal Depth Beside Storage Pantry and Reside Desking Worksurface is recommended.

The front edge of the Storage Pantry aligns with the front edge of the worksurface when both are specified with matching depths.

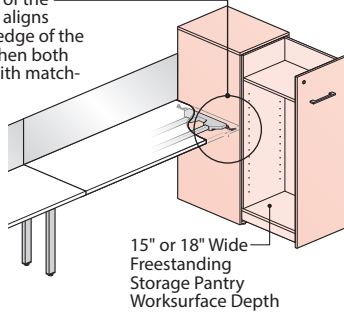

Attachment Brackets for Reside without legs/Adaptable Rectangular Convergent Worksurface (ZUBT-0307-PN)

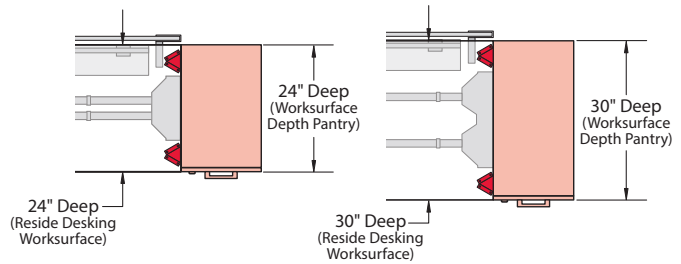

- A deeper Storage Pantry adjacent to a shallower depth Reside Desking Worksurface may be used but is not recommended for aesthetic reasons.

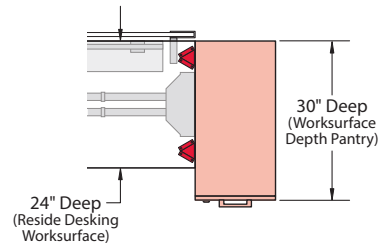
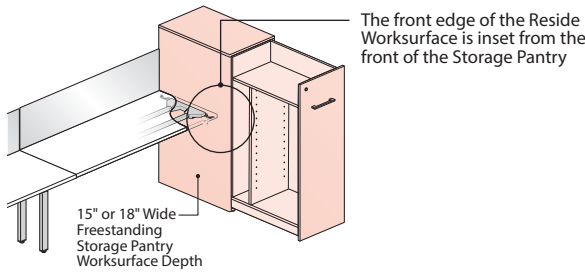

Don't

- A shallower Beside Storage Pantry adjacent to a deeper Reside Desking Worksurface is not recommended for functional and aesthetic reasons.

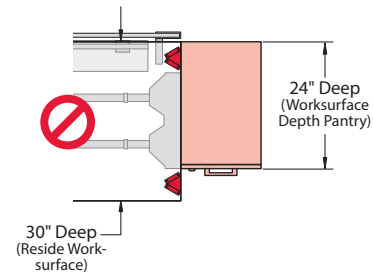
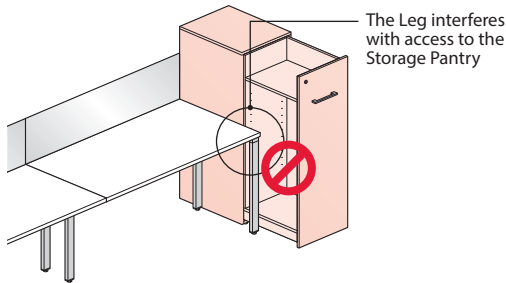

Reside Benching Application – Double Sided – Bracket Supported



Don't

- Back to Back Worksurface Depth Storage Pantries are not for use in a Double Sided Reside Benching Application.

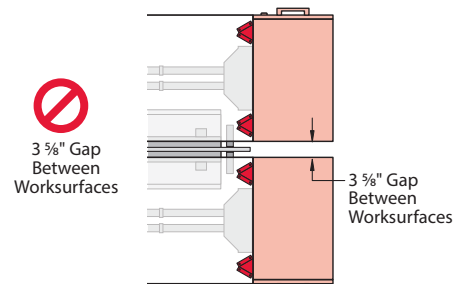
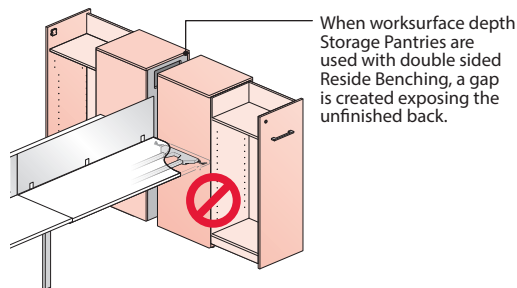

Note 12" wide storage pantry may not be freestanding. Requires (ZKBG-0000-PN) attachment brackets

Product Application – Beside Storage

Storage Pantry / Reside Benching Applications

Basic Guidelines – Storage Pantry (40" and 48" High/Extended Depth) / Reside Benching – Single-Sided

- In the Single Sided Reside Benching application below the Worksurface Depth Storage Pantry is freestanding.
- Storage Pantry must be 15" or 18" wide. A 12" Storage Pantry may not be freestanding.

Finished Back

- A finished back panel may be separately specified as needed. If the back of the storage pantry is exposed a finished back is required.
- Adds $\frac{3}{4}$ " to the depth of the pantry.
- Once installed the finished back is not removable.

Reside Benching Application – Single Sided with Finished Back

A Finished Back is for use in a single sided application when the back of the storage pantry is visible.

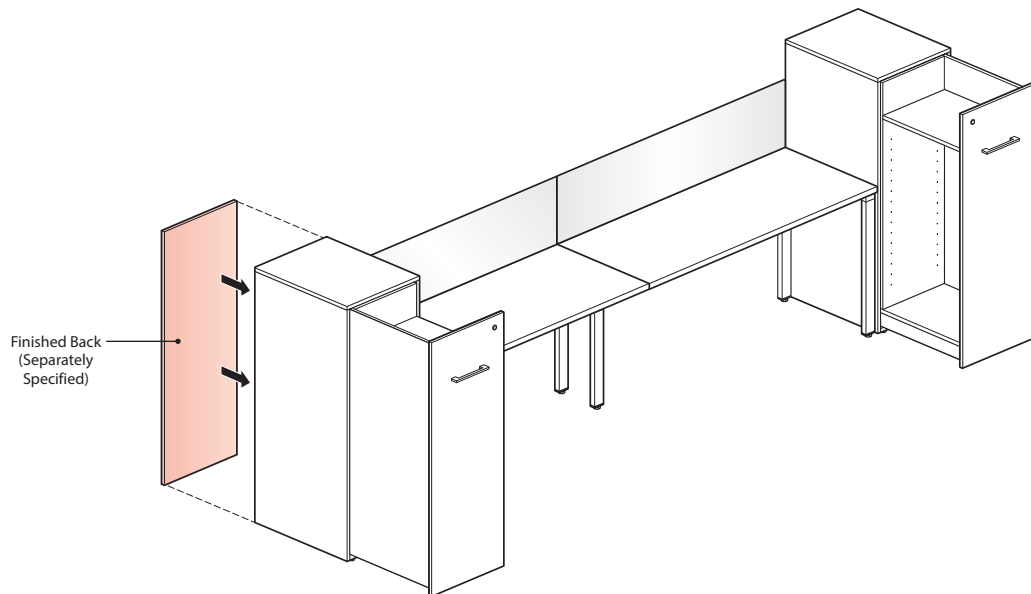

Product Application – Beside Storage

Storage Pantry / Reside Benching Applications

Basic Guidelines – Storage Pantry (40" and 48" High/Extended Depth) / Reside Benching – Double-Sided

- In the Reside Benching applications below the Worksurface Depth Storage Pantry is freestanding.
- Storage Pantry must be 15" or 18" wide. A 12" wide storage pantry may not be freestanding.

Reside Benching Application – Double Sided – Leg Supported

Same nominal depth Beside Storage Pantry and Reside Desking Worksurface is recommended.

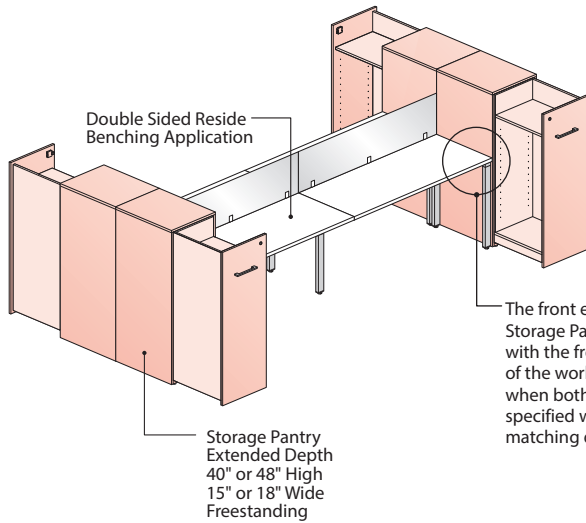

The front edge of the Storage Pantry aligns with the front edge of the worksurface when both are specified with matching depths.

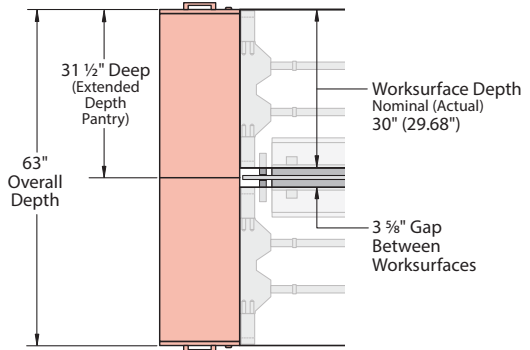
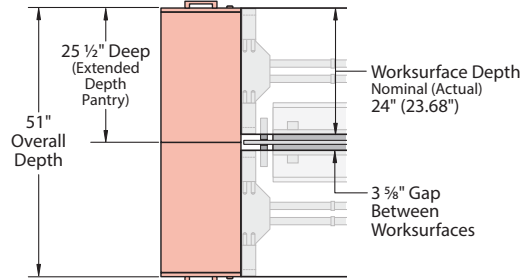

A deeper Beside Storage Pantry adjacent to a shallower depth Reside Desking Worksurface may be used but is not preferred for aesthetic reasons.

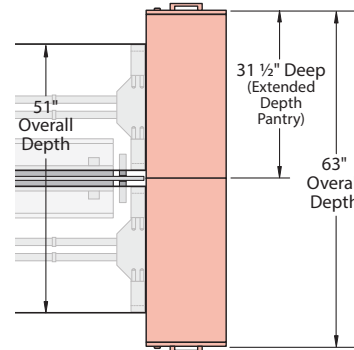
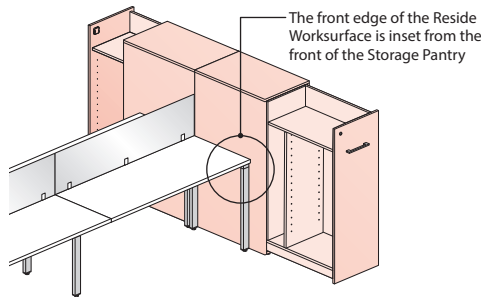

Don't

A shallower Beside Storage Pantry adjacent to a deeper Reside Desking Worksurface is not recommended for functional and aesthetic reasons.

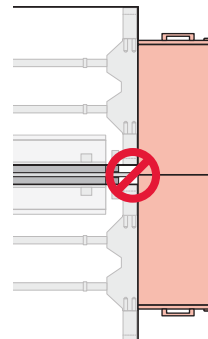
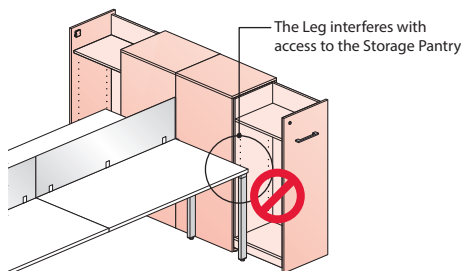

Product Application – Beside Storage

Storage Pantry / Reside Benching Applications

Basic Guidelines –Storage Pantry (40" and 48" High/Extended Depth) / Reside Benching – Double-Sided

- The Extended Depth Beside Storage Pantries are designed for a back-to-back/side-to-side applications in 51" deep Reside double sided benching applications require back-to-back 25 ½" deep Storage Pantries.
- 63" deep Reside double sided benching applications require back-to-back 31 ½" deep Storage Pantries.
- 15" and 18" wide Storage Pantries may be freestanding.
- 12" wide Storage Pantries cannot be freestanding, they always require side-to-side ganging.

Reside Benching Application – Double Sided – Bracket Supported

The Reside Benching application and the Beside Storage Pantries are not attached. The Benching Application is supported by legs that stand adjacent to the Beside Storage Unit

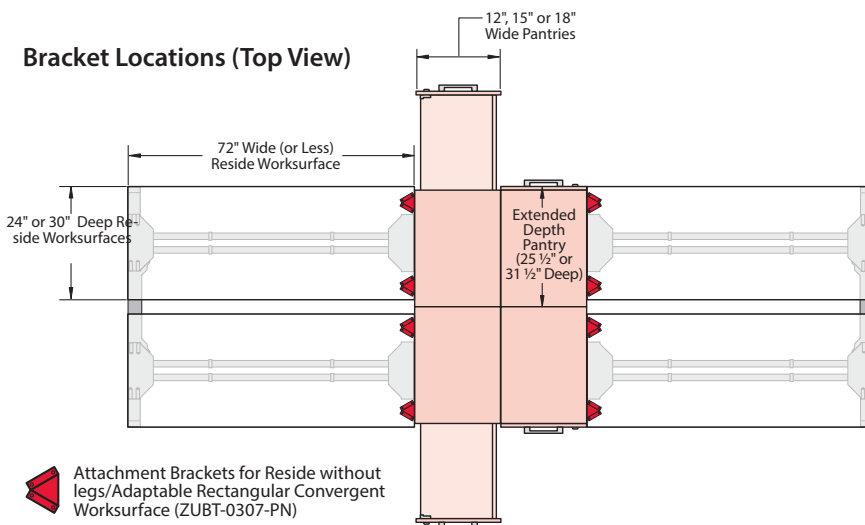
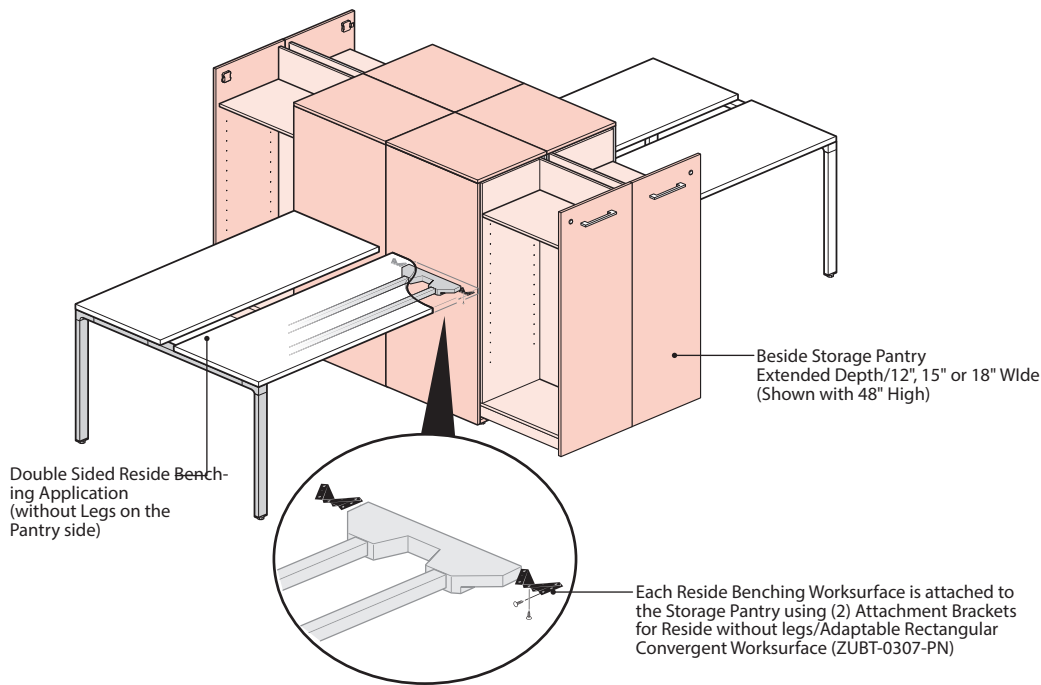

Note Using an Attachment Bracket to attach the worksurface to the Storage Pantry eliminates the need for field supplied ganging hardware; applies to all pantry widths 12", 15" and 18" wide Storage Pantries.

Product Application – Beside Storage Pantry

Storage Pantry / Reside Benching Applications

Guidelines for Storage Pantry Power Pass Through Applications for Leg Supported Reside Benching

To facilitate the routing of power through Beside Storage Pantries, a separately specified Grommet (KUAG-0204-PA) may be installed in field drilled holes on the side of the Beside Storage Pantry.

- The Grommet allows a power Jumper to be passed through the back of a Storage Pantry(s), from one Reside benching application to another.
- Storage Pantry applications specified with power components must be ganged to the Reside benching application. A Separately specify Attachment Bracket for use with Reside Legs (ZKBG-0000-PN) is required for each Reside worksurface.
- When power is routed through multiple Storage Pantries, they must be ganged together side-to-side (not back-to-back). Installer to supply ganging hardware.

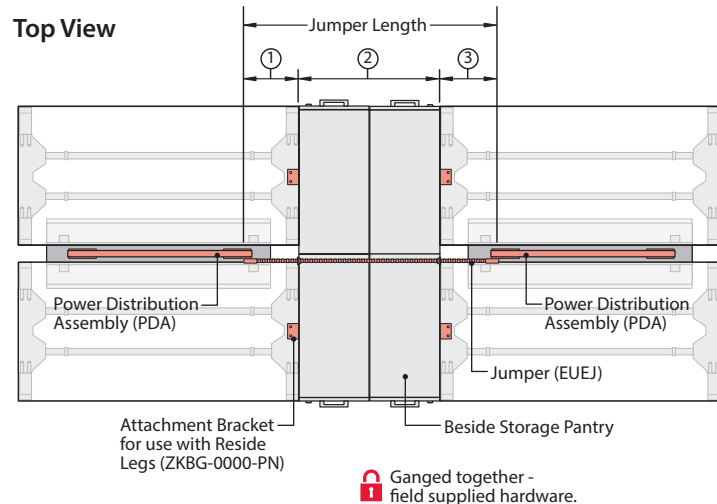
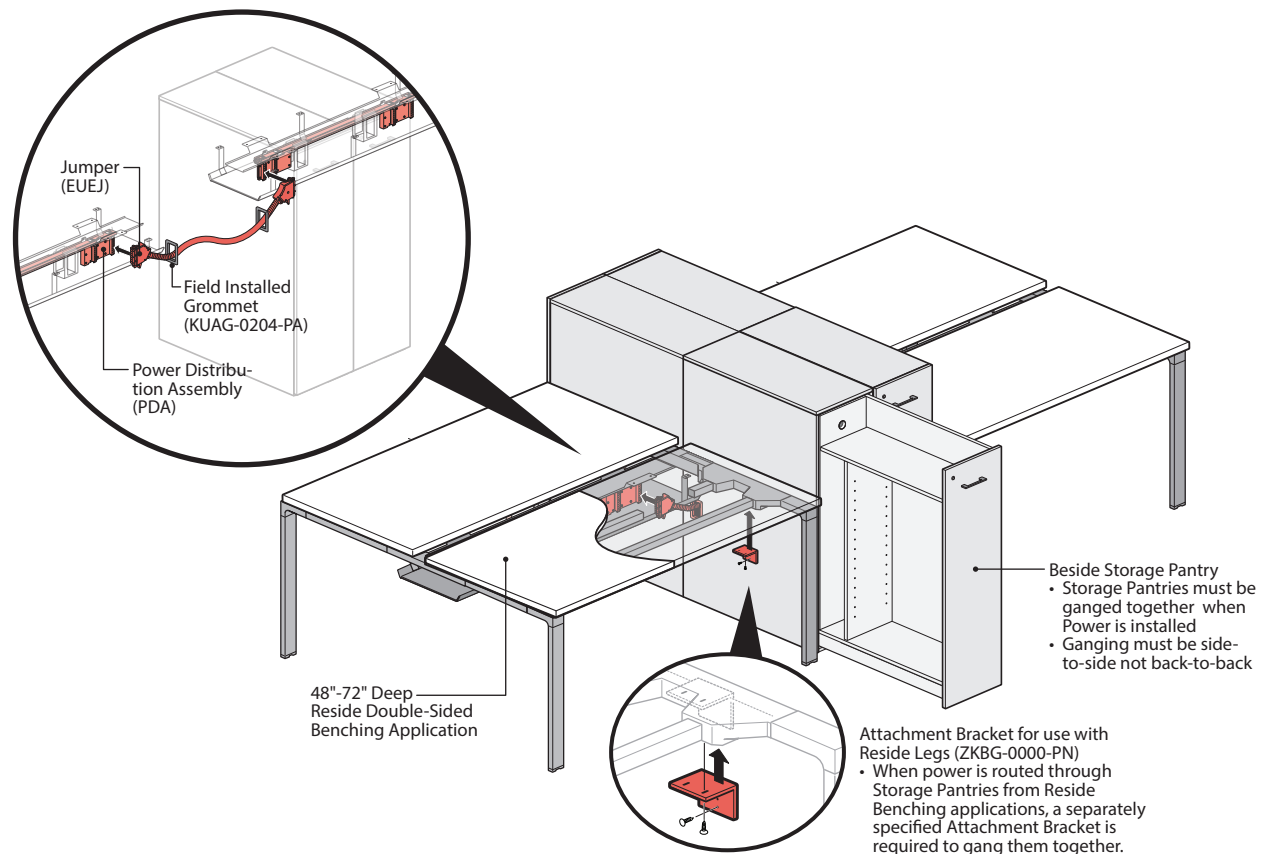

Calculating Jumper Length

- To calculate appropriate Jumper length, add the following:
 - ① 12" (distance between PDA and Pantry)
 - ② Width of Storage Pantry(s)
 - ③ 12" (distance between PDA and Pantry)

Jumper Length Example:

$$\begin{array}{r}
 12'' \text{ ① distance between PDA and Pantry} \\
 30'' \text{ ② Width of Storage Pantries} \\
 + 12'' \text{ ③ distance between PDA and Pantry} \\
 \hline
 54'' \text{ Required Jumper Length}
 \end{array}$$

Product Application – Beside Storage

Storage Pantry / Reside Benching Applications

Guidelines for Storage Pantry Power Pass Through Applications for Bracket Supported Reside Benching

To facilitate the routing of power through Beside Storage Pantries, a separately specified Grommet (KUAG-0204-PA) may be installed in field drilled holes on the side of the Beside Storage Pantry.

- The Grommet allows a power Jumper to be passed through the back of a Storage Pantry(s), from one Reside benching application to another.
- Each Reside Benching Worksurface is attached to the Storage Pantry using (2) Attachment Brackets for Reside without legs/Adaptable Rectangular Convergent Worksurface (ZUBT-0307-PN).
- When power is routed through multiple Storage Pantries, they must be ganged together side-to-side (not back-to-back). Installer to supply ganging hardware.

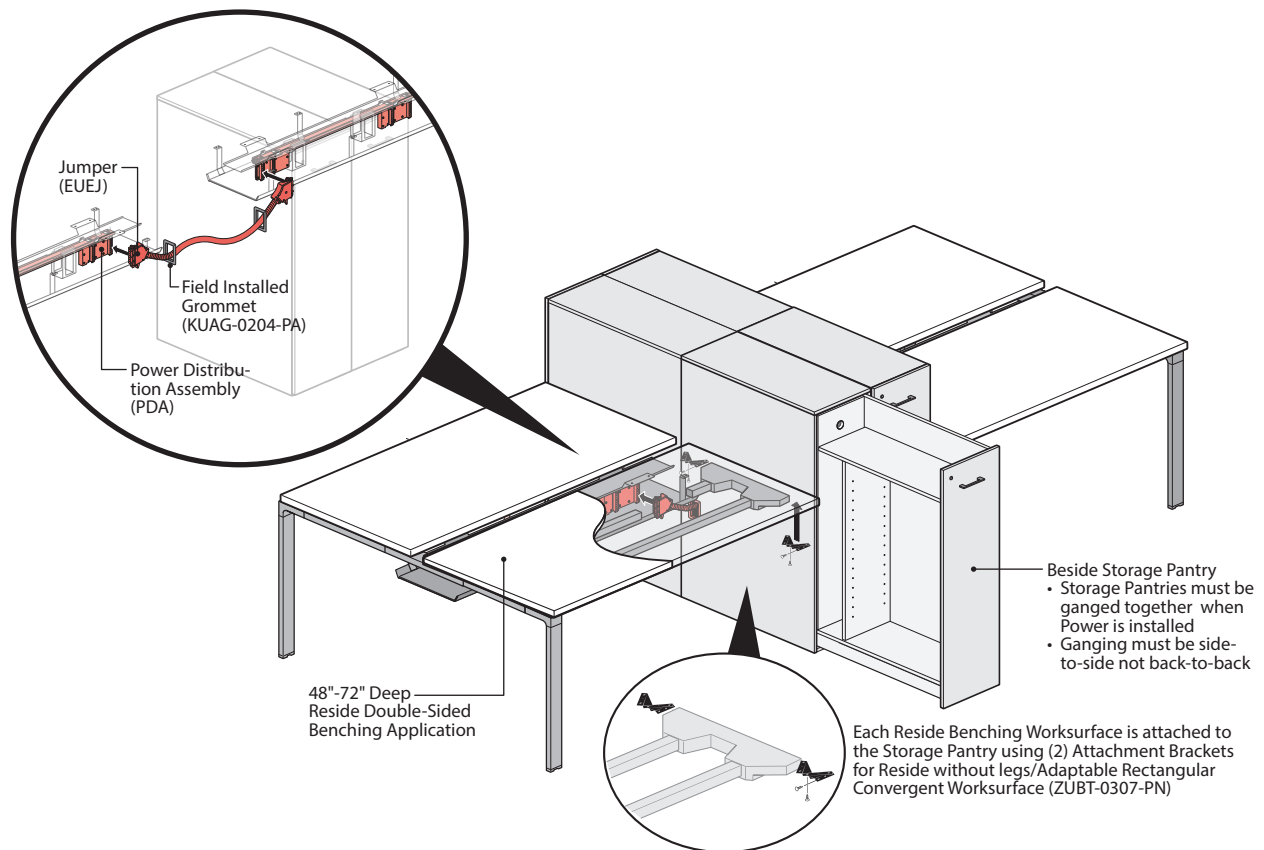

Top View

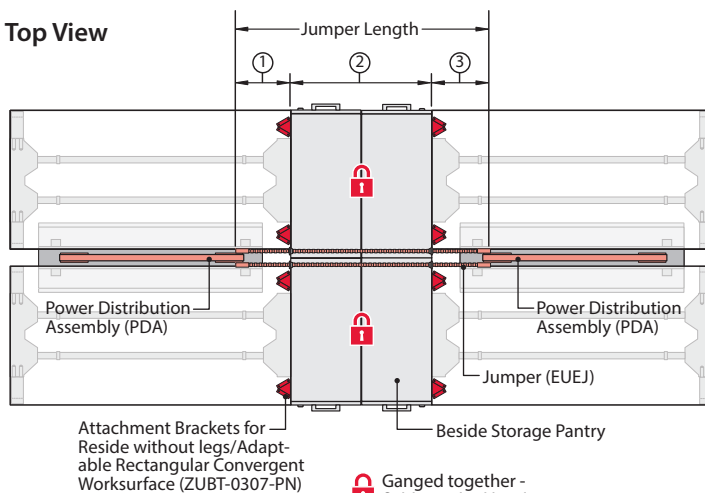

Calculating Jumper Length

- To calculate appropriate Jumper length, add the following:

- ① 12" (distance between PDA and Pantry)
- ② Width of Storage Pantry(s)
- ③ 12" (distance between PDA and Pantry)

Jumper Length Example:

$$\begin{array}{r}
 12'' \text{ ① distance between PDA and Pantry} \\
 30'' \text{ ② Width of Storage Pantries} \\
 + 12'' \text{ ③ distance between PDA and Pantry} \\
 \hline
 54'' \text{ Required Jumper Length}
 \end{array}$$

Product Application – Beside Storage

Storage Pantry / Intuity Benching Applications

The Storage Pantry may be used with Intuity single or double-sided benching applications.

Application Guidelines – Storage Pantry (40" and 48" High/Extended Depth) / Intuity Benching – Single-Sided

- 24" deep Intuity Worksurfaces are for use with 24" Deep (Worksurface Depth) Beside Storage Pantries.
- 30" deep Intuity Worksurfaces are for use with 30" Deep (Worksurface Depth) Beside Storage Pantries.
- 15" and 18" wide Storage Pantry may be freestanding.
- 12" Wide Storage Pantry cannot be freestanding, requires side-to-side ganging.

- Note**
- The 28" High Storage Pantry is not for use with Intuity worksurfaces due to interference with the Leg Kit under structure.
 - If the back of the Storage Pantry is visible a separately specified finished back is required.

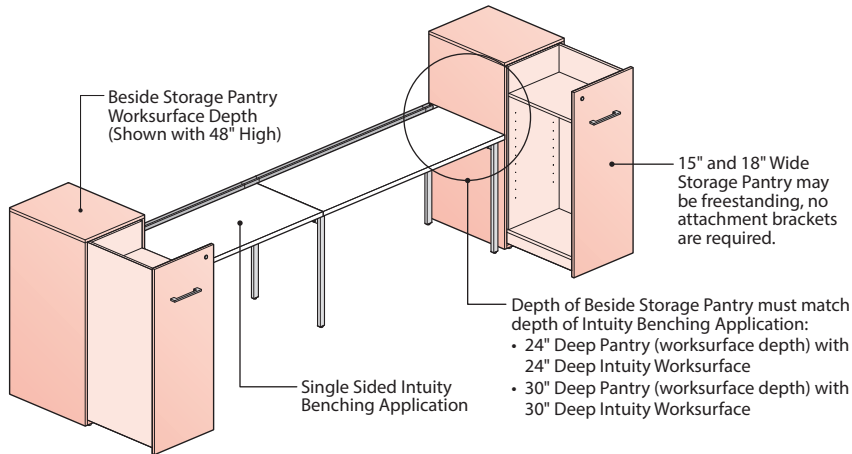

Application Guidelines – Storage Pantry 40" and 48" High Extended Depth / Intuity Benching – Double-Sided

- Specify back-to-back 25 1/2" deep extended depth Beside Storage Pantries for applications with 51" deep double-sided benching applications (back-to-back 24" Deep Intuity worksurfaces).
- Specify back-to-back 31 1/2" deep extended depth Beside Storage Pantries for applications with 63" deep double-sided benching applications (back-to-back 30" Deep Intuity worksurfaces).
- 15" and 18" Wide Storage Pantry may be freestanding.
- 12" Wide Storage Pantry cannot be freestanding, requires side-to-side ganging.

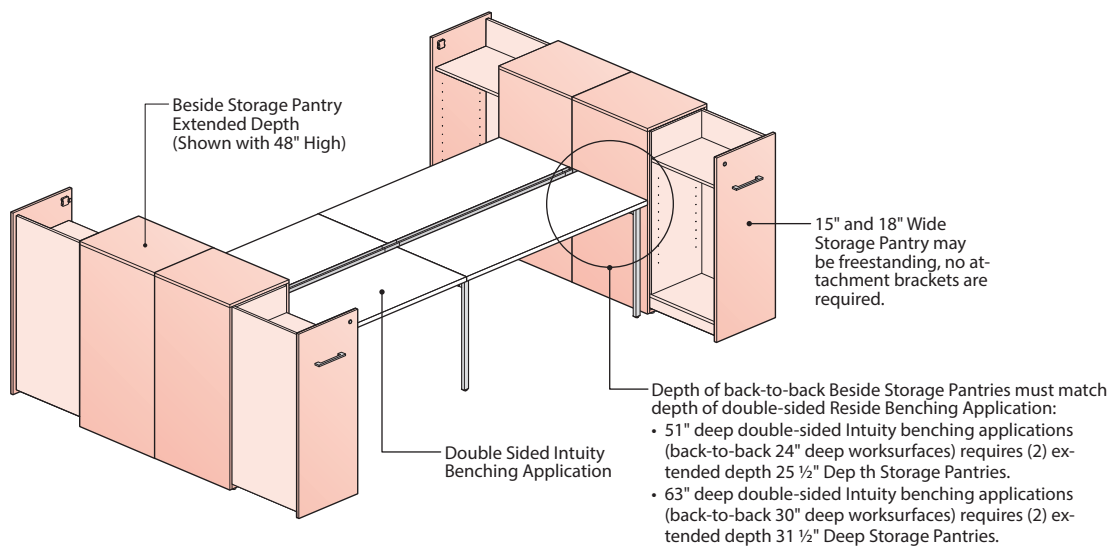

- Note**
- If legs are not used adjacent to storage pantry separately specified Attachment brackets are required for worksurface support.

Product Application – Beside Storage

Storage Pantry / Intuity Benching Applications

Application Guidelines – Storage Pantry (40" and 48" High/Extended Depth) / Intuity Benching

- In the Intuity Benching applications below the Worksurface Depth Storage Pantry is freestanding.
- Storage Pantry must be 15" or 18" wide. A 12" Storage Pantry may not be freestanding.

Storage Pantry – 40" and 48" High Extended Depth / Intuity Benching – Single Sided Application

Same Nominal Depth Beside Storage Pantry and Intuity Desking Worksurface is recommended.

The front edge of the Storage Pantry aligns with the front edge of the worksurface when both are specified with matching depths.

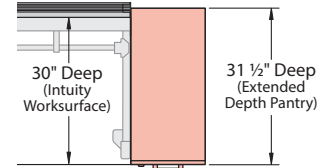
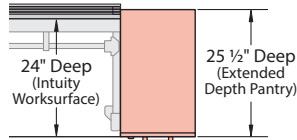
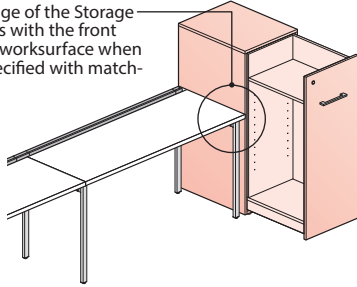

A deeper Beside Storage Pantry adjacent to a shallower depth Intuity Desking Worksurface may be used but is not recommended for aesthetic reasons.

The front edge of the Reside Worksurface is inset from the front of the Storage Pantry

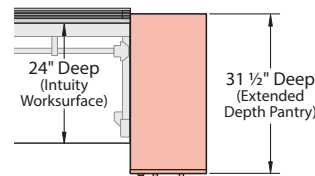
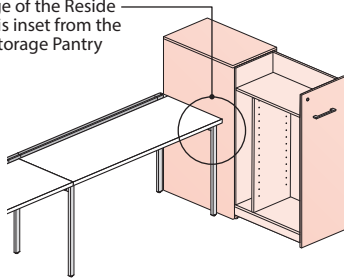

Don't

A shallower Beside Storage Pantry adjacent to a deeper Intuity Desking Worksurface is not recommended for aesthetic reasons.

Intuity Leg interferes with access to the Storage Pantry

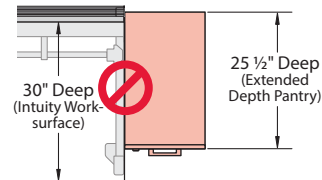
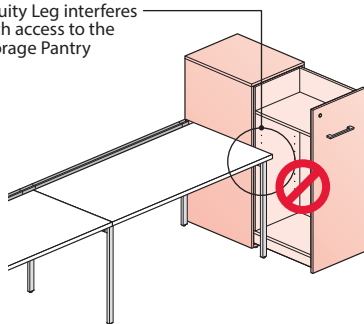

Storage Pantry – 40" and 48" High Extended Depth / Intuity Benching – Double Sided Application



Don't

Back to Back Worksurface Depth Storage Pantries are not for use in a Double Sided Intuity Benching Application.

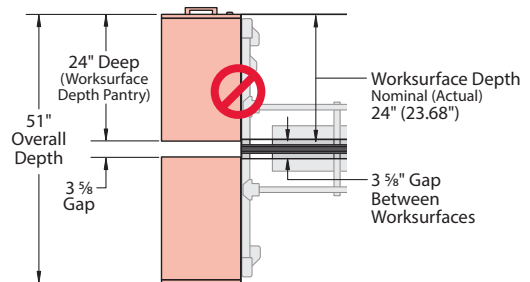
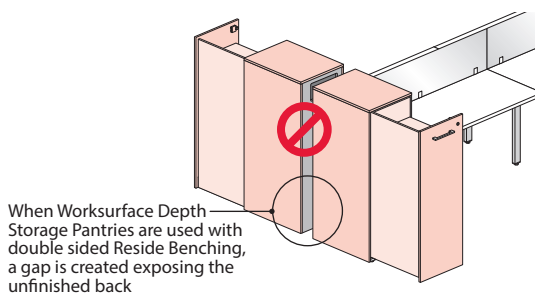

Product Application – Beside Storage

Storage Pantry / Intuity Benching Applications

Application Guidelines – Storage Pantry (40" and 48" High Extended Depth) / Intuity Benching – Single-Sided

- In the Intuity Benching applications below the Worksurface Depth Storage Pantry is freestanding.
- Storage Pantry must be 15" or 18" wide. A 12" Storage Pantry may not be freestanding.

Finished Back

- A finished back panel may be separately specified as needed. If the back of the storage pantry is exposed a finished back is required.
- Adds $\frac{3}{4}$ " to the depth of the pantry.
- Once installed the finished back is not removable.

Intuity Desking Application – Single Sided

A Finished Back is for use in a single sided application when the back of the storage pantry is visible.

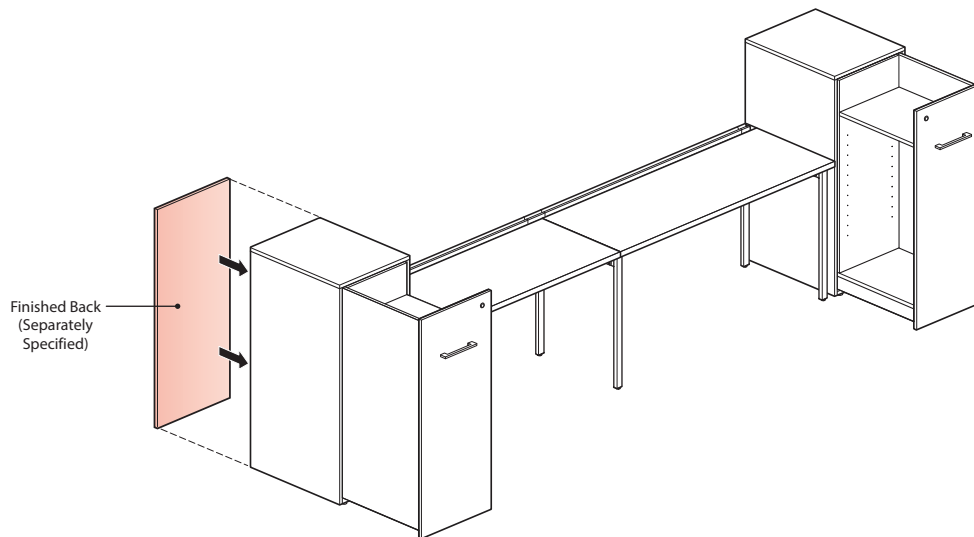

Product Application – Beside Storage

Storage Pantry / Intuity Benching Applications

Application Guidelines – Storage Pantry (40" and 48" High Extended Depth) / Intuity Benching – Double-Sided

- The Extended Depth Storage Pantry is 1.5" deeper than the Worksurface Depth Storage Pantry.
- Extended Depth Storage Pantries are to be used in a back-to-back condition.
- The overall depth of the Pantries fill the 3" panel gap at the end-of-run.
- In the Reside Benching applications below the Extended Depth Storage Pantries are freestanding.
- Storage Pantry must be 15" or 18" wide. A 12" Storage Pantry may not be freestanding.

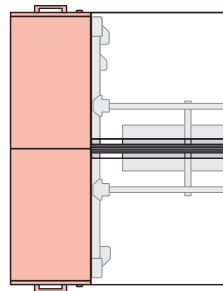

- 40 or 48" high Freestanding
- Extended Depth Storage Pantry
- 15" or 18" wide Storage Pantries, only

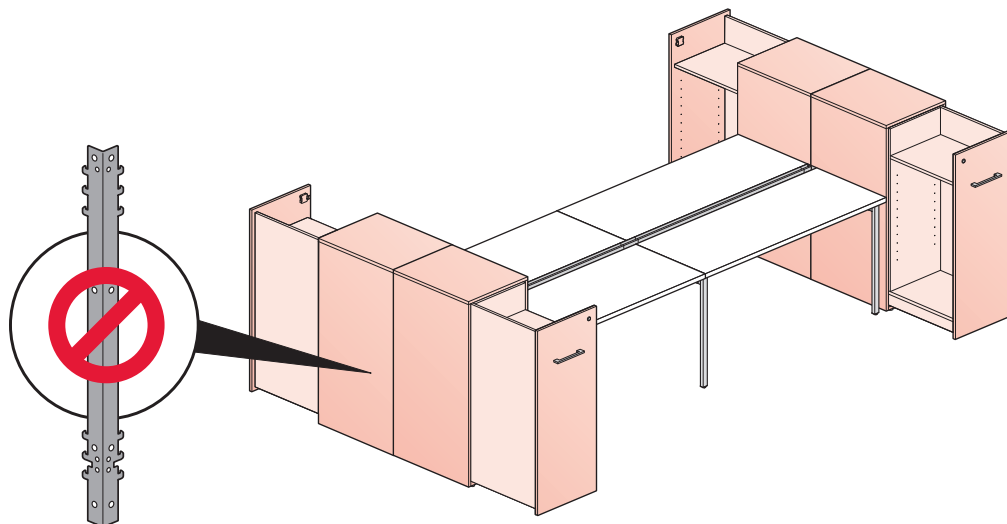

Compose
Panel-to-Storage
Bracket -C1
(ZZBF-1800-PNW)

ZZBG-1800-PNW bracket is not for a benching application; for use with Compose Panel System, only. The storage pantries in this application are freestanding. Therefore, they must be 15" or 18" wide; a 12" wide storage pantry may not be freestanding.

Note

- Refer to the Intuity Desking Specification Guide for additional benching application guidelines.

Product Application – Beside Storage

Storage Pantry / Intuity Benching Applications

Application Guidelines – Storage Pantry (40" and 48" High Extended Depth) / Intuity Benching – Double-Sided

- In the Intuity Benching applications below the Worksurface Depth Storage Pantry is freestanding.
- Storage Pantry must be 15" or 18" wide. A 12" Storage Pantry may not be freestanding.

Intuity Benching Applications – Double Sided

Same Nominal Depth Beside Storage Pantry and Reside Desking Worksurface is recommended.

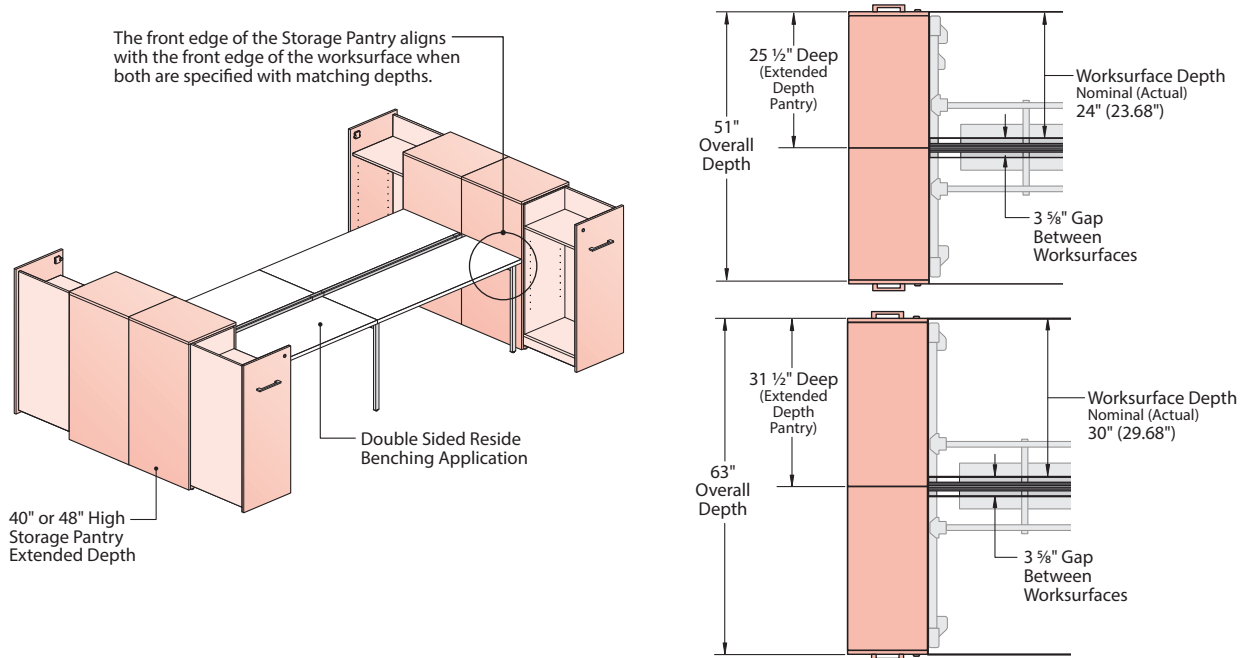

A deeper Beside Storage Pantry adjacent to a shallower depth Reside Desking Worksurface may be used but is not preferred for aesthetic reasons.

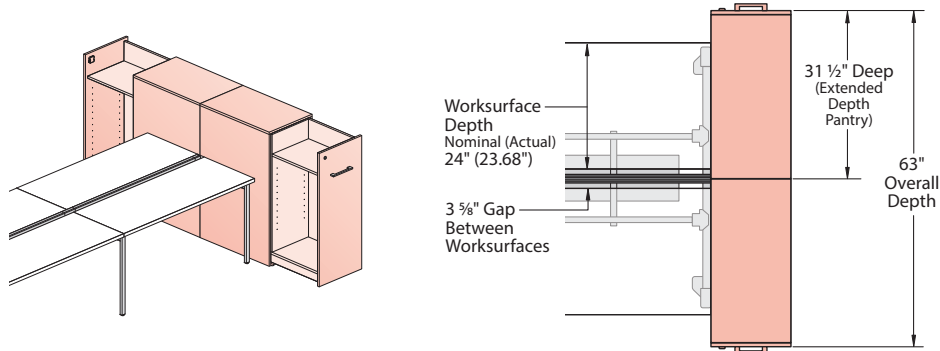

Don't A shallower Beside Storage Pantry adjacent to a deeper Reside Desking Worksurface is not recommended for functional and aesthetic reasons.

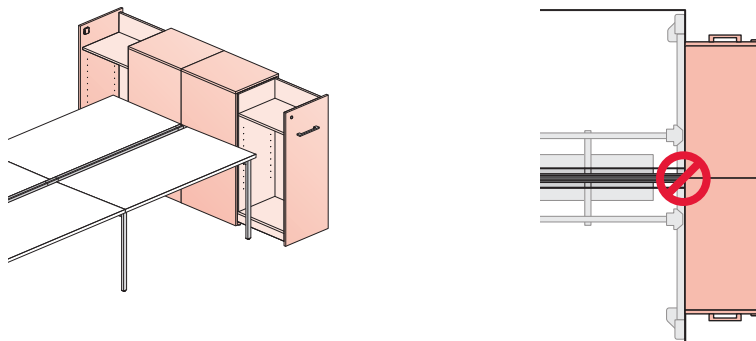

Product Application – Beside Storage Pantry

Storage Pantry / Intuity Benching Applications

Application Guidelines for Storage Pantry Power Pass Through

- To facilitate the routing of power through Beside Storage Pantries, a separately specified Grommet (KUAG-0204-PA) may be installed in field drilled holes on the side of the Beside Storage Pantry.
- The Grommet allows a power Jumper to be passed through the back of a Storage Pantry(s), from one Intuity benching application to another.
- Storage Pantry applications specified with power components must be ganged to the Intuity benching application. A Separately specify Attachment Bracket for use with Intuity (ZKBB-0000-PN) is required for each Intuity worksurface.
- When power is routed through multiple Storage Pantries, they must be ganged together side-to-side (not back-to-back). Installer to supply ganging hardware.

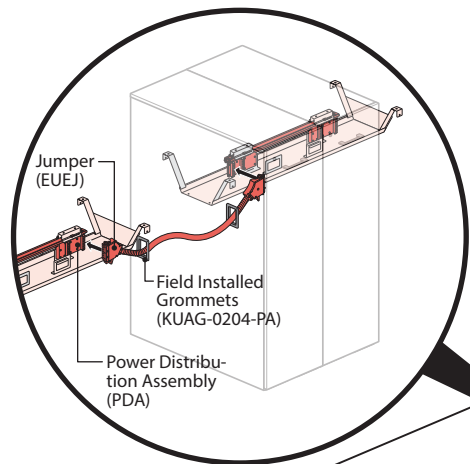

- Note**
- A quantity of (2) Grommets are required for use with each jumper. One for the exposed entry site and one for the exposed exit site.
 - The Attachment bracket is not designed to support the Intuity Benching application. The benching application must be supported with intuity legs.

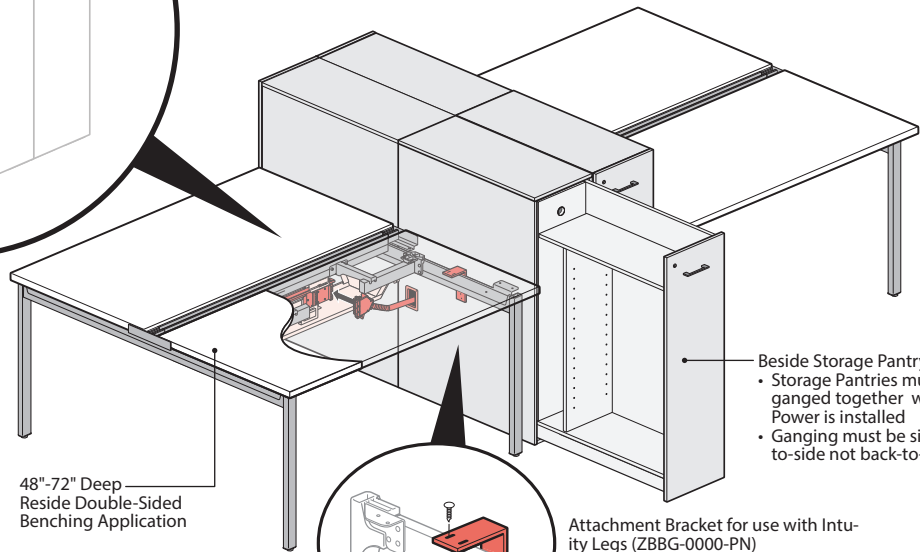

- Beside Storage Pantry**
- Storage Pantries must be ganged together when Power is installed
 - Ganging must be side-to-side not back-to-back

- Attachment Bracket for use with Intuity Legs (ZBBG-0000-PN)**
- When power is routed through Storage Pantries from Reside Benching applications, a separately specified Attachment Bracket is required to gang them together.

Top View

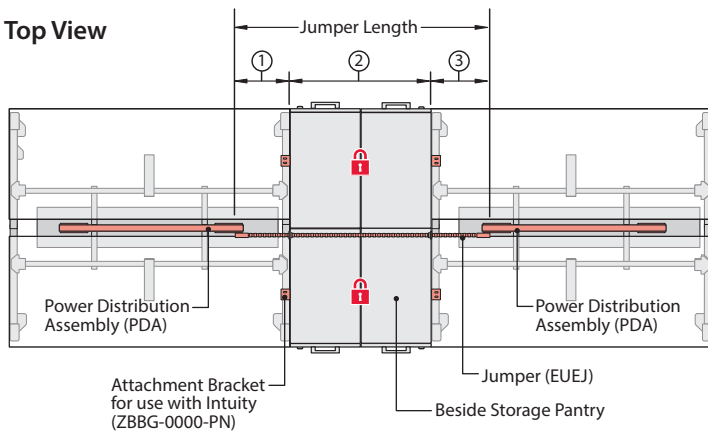

Ganged together - field supplied hardware.

Calculating Jumper Length

- To calculate appropriate Jumper length, add the following:
 - ① 12" (distance between PDA and Pantry)
 - ② Width of Storage Pantry(s)
 - ③ 12" (distance between PDA and Pantry)

Jumper Length Example:

$$\begin{array}{r}
 12'' \text{ ① distance between PDA and Pantry} \\
 30'' \text{ ② Width of Storage Pantries} \\
 + 12'' \text{ ③ distance between PDA and Pantry} \\
 \hline
 54'' \text{ Required Jumper Length}
 \end{array}$$

Product Application – Beside Storage

Storage Pantry / Planes Height Adjustable Table Bench Applications

Basic Guidelines – Storage Pantry – (40" and 48" High/Extended Depth) / Planes Height Adjustable Table Bench

- Specify back-to-back 25 ½" deep extended depth Beside Storage Pantries for applications with 51" deep double-sided benching applications (back-to-back 24" Deep worksurfaces).
- Specify back-to-back 31 ½" deep extended depth Beside Storage Pantries for applications with 63" deep double-sided benching applications (back-to-back 30" Deep worksurfaces).
- 15" and 18" Wide Storage Pantry may be freestanding.
- 12" Wide Storage Pantry cannot be freestanding, requires side-to-side ganging.
- All pantries with power components routed through the back must be ganged side-to-side.

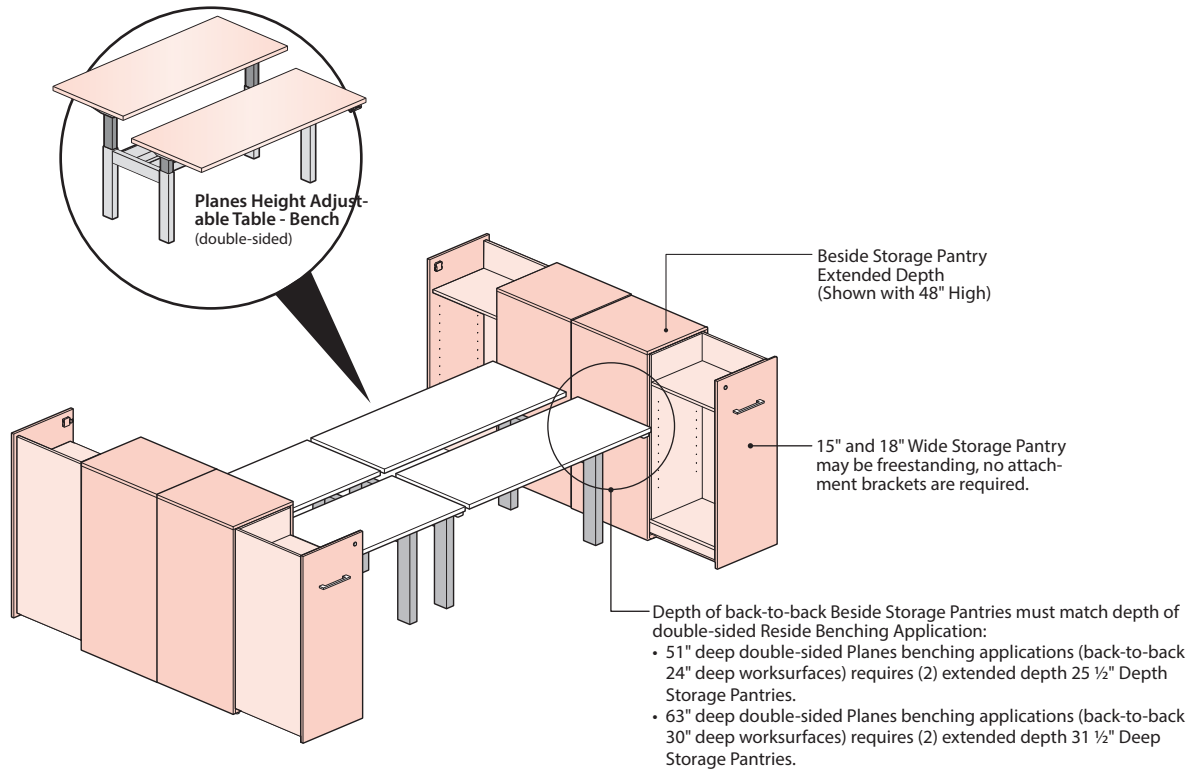

Note The 28" High Beside Storage Pantry is not for use with the Planes Height Adjustable Table Bench, since the Pantry cannot be attached to a height adjustable worksurface.

Product Application – Beside Storage

Storage Pantry / Planes Height Adjustable Table Bench Applications

Basic Guidelines – Storage Pantry – (40" and 48" High/Extended Depth) / Planes Height Adjustable Table Bench

- In the Planes Height Adjustable Table Bench applications below the Extended Depth Storage Pantry is freestanding.
- Storage Pantry must be 15" or 18" wide. A 12" Storage Pantry may not be freestanding.

Double Sided / Planes Height Adjustable Table -Bench Applications

Same Depth Beside Storage Pantry and Planes Height Adjustable Benching –Table is recommended.

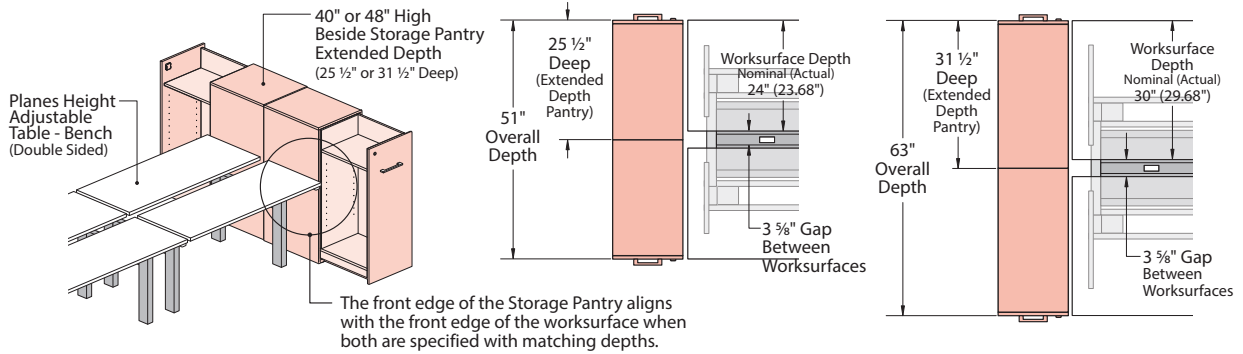

A deeper Beside Storage Pantry adjacent to a shallower depth Planes Height Adjustable Table -Bench may be used but is not recommended for aesthetic reasons.

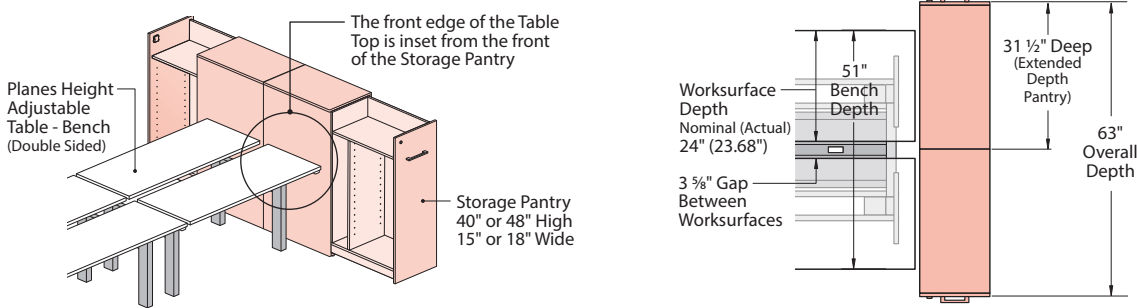

Don't A deeper Beside Storage Pantry adjacent to a shallower depth Planes Height Adjustable Table -Bench may be used but is not recommended for aesthetic reasons.

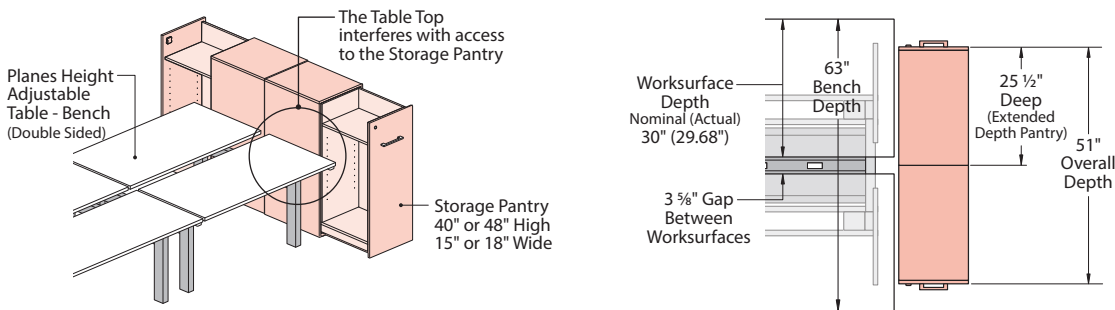

Don't Back to Back Worksurface Depth Storage Pantries are not for use in a Planes Height Adjustable Table Bench Application.

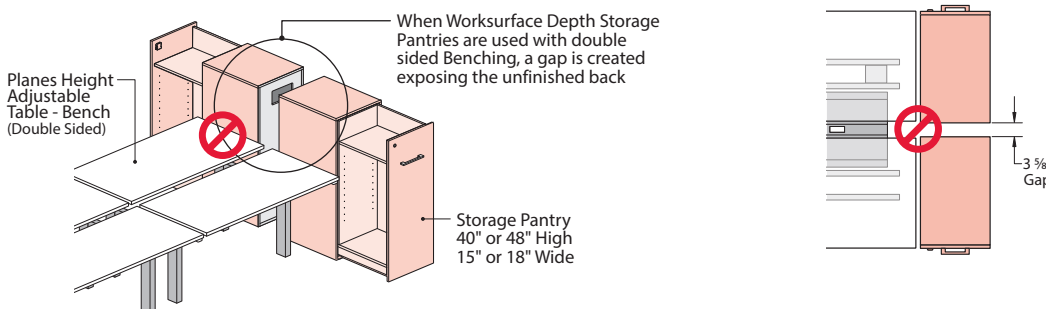

Product Application – Beside Storage

Storage Pantry / Planes Height Adjustable Table Bench Applications

Basic Guidelines – Storage Pantry – (40" and 48" High/Extended Depth) / Planes Height Adjustable Table Bench

- The Extended Depth Beside Storage Pantries are designed for back-to-back/side-to-side applications with adjacent Planes Height Adjustable Table - Bench.
- An Attachment Bracket to connect the Pantry and the Benching application are only required when power is routed from the benching application through the Pantry.
- 51" deep Beside double sided benching applications require back-to-back 25 ½" deep Storage Pantries.
- 63" deep Beside double sided benching applications require back-to-back 31 ½" deep Storage Pantries.
- 15" or 18" wide Beside Storage Pantries may be freestanding when adjacent to Intuity Benching Applications.
- 12" wide Beside Storage Pantries cannot be freestanding, they must be ganged together side-to-side.

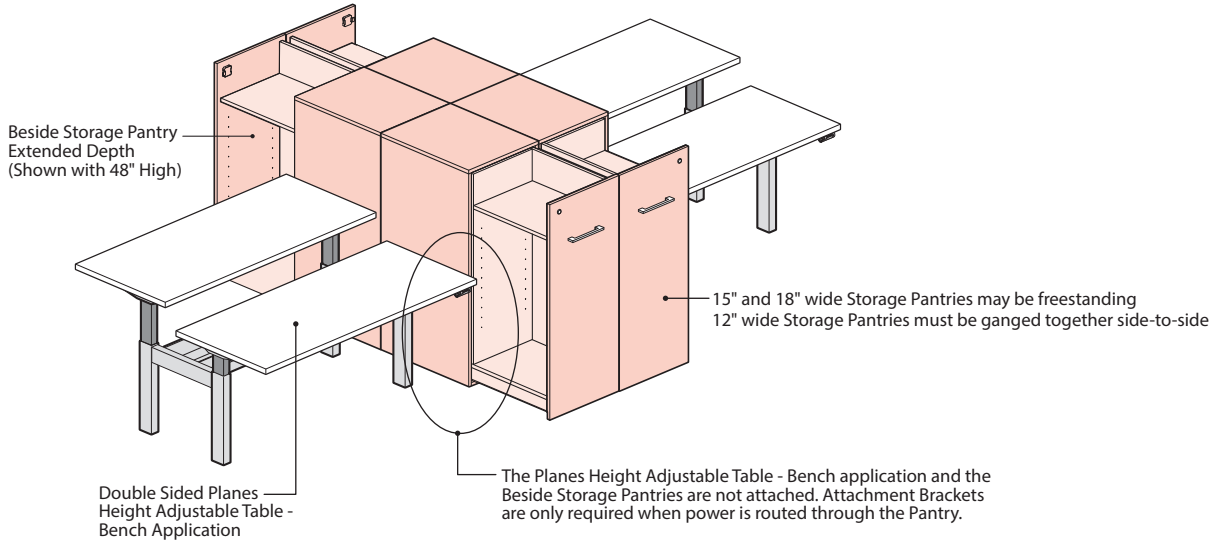

12" Wide Storage Pantry

- 12" wide Storage Pantries must be ganged to another pantry for support and load reasons.
- Installer to supply ganging hardware.
- Must be ganged together side-to-side not back-to-back.

15" and 18" Wide Storage Pantry

- Storage Pantry widths 15" and 18" may be freestanding.
- Must be bracket attached, only when power is passed through the Storage Pantries from the Planes Height Adjustable Table - Bench.

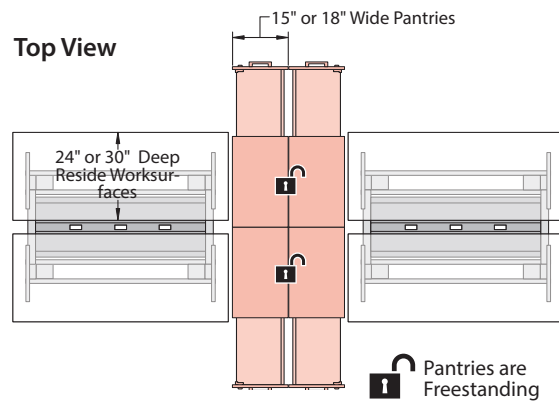
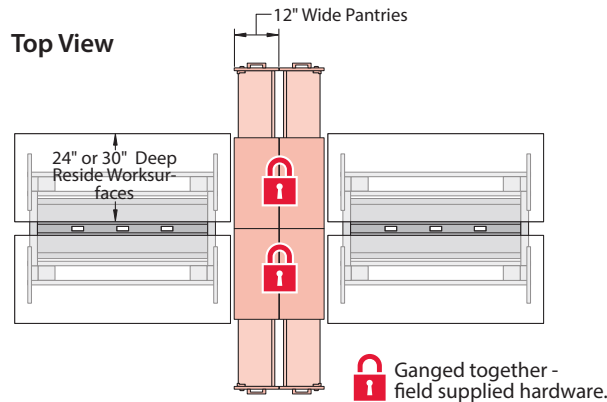

Technical Specifications Beside Storage

Technical Specifications – Beside Storage

Storage Base Unit

Base unit is constructed with wood composite end panels and an inner top with a formed steel bottom and back. End panels and inner tops are .750" (19mm) thick with a wood composite core sandwiched between two laminate skins and 0.039" (1mm) thick plastic edgeband around the perimeter. The bottom and inner back are made with 20 gauge steel with a powdercoat finish. Base units include a utility cavity for routing power and data/communication cabling at the back of each unit. This cavity can be covered by an optional back available in painted steel, laminate or wood veneer. Base units 30" to 72" wide have cut outs in the steel bottom for routing of electrical components and data/communications cables. Cutouts are 1.5", 38mm x 4", 102mm. Fixed and optional shelves are made from 22 gauge formed steel. Base units have a formed steel black powder coated spacer with access opening (with knock-out) to route power and data cabling from the storage unit to attached desk top. The spacer provides a 1.18" (30 mm) high reveal between steel top of unit and separately specified laminate or wood veneer storage unit tops. Vertical and horizontal power receptacles with three outlets can be mounted on storage unit tops in various locations. The unit is shipped assembled and support legs are field installed. The straight leg option includes glides with 1.5" height adjustment and chamfer leg option glides have 1.25" adjustment. Units are available with drawers, doors, or open storage. Open units and units with doors accept separately specified storage shelves. Doors are available in pivot/swing with self closing hinges that open to 100 degree angle or sliding doors. Units with drawers include full-extension steel ball bearing slides. Drawers and shelves can be loaded to 0.017 pounds per cubic inch of clear volume. Drawer interlock system allows only one drawer to open at a time. Drawer bottoms and backs are made with 22 gauge steel and sides are made with 20 gauge steel. Doors and drawers can be specified with or without locks. The vertically hinged and sliding doors require less than 4.8 pounds of force to operate. Doors, drawer fronts and optional backs are available in the following materials:

- Painted Steel- 11/16" (17.5 mm) thick formed with 22 gauge steel with powder coat finish.
- Laminate - 11/16" (17.5mm) thick with a wood composite core and high pressure laminate over the face and back with ABS edge band.
- Wood Veneer – 11/16" (17.5mm) thick with a wood composite core and wood veneer over the face with a balancing backer and wood veneer edge band.

Storage Tops for Base Units

Storage Tops are 1 3/16" (30.2mm) thick and are made with a wood composite core available in two core types.

- **Standard Core:** Made with an engineered composite panel with a minimum 90% wood fiber content with at least 10% post consumer and 80% pre-consumer wood fiber bonded with resin. These worksurfaces/tops are 3rd party certified compliant with GREENGUARD® and ANSI/BIFMA Standards for Low Emitting Products. The composite panel is 3rd party certified compliant with California Air Resource Board requirements for Phase 2 formaldehyde emission levels.
- **Green Core:** Made with an engineered composite panel with a minimum 90% pre-consumer wood fiber content bonded with no-added urea formaldehyde resin. These worksurfaces/tops are 3rd party certified compliant with GREENGUARD® and ANSI/BIFMA Standards for Low Emitting Products. The composite panel is 3rd party certified compliant with California Air Resource Board requirements for Phase 2 formaldehyde emission levels.

Laminate Storage Tops are balanced construction with high-pressure laminate on the top, a laminate backer on the bottom and 0.118" (3mm) radius edge band on the front and back edge with a 0.039" (1mm) thick edge band on the sides.

Wood Veneer Storage Tops are balanced construction with wood veneer on the top, a balancing backer on the bottom and a 0.118" (3mm) radius edge band on the front and back edge with a 0.028" (.7mm) thick edge band on the sides.

Technical Specifications – Beside Storage

Hutch

Hutches are made by combining stanchions and shelves or overhead storage units. Stanchions are made with 16 gauge formed steel ends, center supports and horizontal extensions (backs). Extensions (backs) with optional integrated accessory slots are made from 13 gauge formed steel. Horizontal extensions nest into the end and center supports. Stanchions and horizontal extensions are powdercoated. Stanchions can support hutch shelves or an overhead storage unit. Shelves are made with .750" (19mm) thick wood composite material with laminate faces and 1mm thick plastic edgeband or .728" (18mm) thick wood composite material with veneer faces and matching edgeband. Pilot holes are partially drilled on the bottom side to allow multiple stanchion mounting positions by drilling through the proper hole pattern. Hutches attach to storage unit tops that are attached to Base Units.

Overhead Storage Units

Wood and Laminate Overhead Storage Units (OSU) consisting of a case that includes a top, bottom, ends, backs and a center divider for widths greater than 60" are constructed of .750", 19mm thick wood composite material with laminate faces and 1mm thick ABS edgeband or .728", 18mm thick wood composite material with veneer faces and matching edgeband. OSU's can be attached onto stanchions mounted to storage tops attached to base units. They can also be attached to Compose aluminum and wood veneer panel top caps, or to Premise and Unigroup Too panels with formed steel brackets. Units ship unassembled. Units with single sliding doors have a center divider that sections off half the unit. Sliding door units and units without doors can be specified to have a full depth opening on ½ of each face of the unit. Units are available with pivot/swing door, sliding doors or without doors. Doors can be specified with or without locks. The vertically hinged and sliding door types require less than 4.8 pounds of force to operate. Doors are available in the following materials:

- Painted Door – 11/16" (17.5mm) thick formed with 22 gauge (0.030", 0.76mm) thick steel with powder coat finish.
- Laminate Door - 11/16" (17.5mm) thick with a wood composite core and high pressure laminate over the face and back with ABS edge band.
- Wood Door – 11/16" (17.5mm) thick with a wood composite core and wood veneer over the face with a balancing backer and wood veneer edge band.

Screens

Screens attach to storage base units with powder coated aluminum "U" brackets attached to a steel plate with threaded fasteners. This bracket assembly attaches to the bottom side of storage unit tops with threaded fasteners. Fabric, Laminate and wood veneer screens are held in the "U" bracket with a threaded set screw. For glass screens a plastic gasket fits into the "U" bracket and the screens are friction fit into the plastic gasket. Screens are available in the following materials:

- Fabric screens are made with 0.5" (12.7mm) thick non-tackable wood composite core with fabric bonded to the faces and edges and the seams covered by a plastic spline that surrounds the edge perimeter.
- Laminate screens consist of .5" (12.7mm) thick wood composite core with high pressure laminate bonded to the faces and the edges capped with a .039" (1mm) plastic edge.
- Wood Veneer screens consist of .5" (12.7mm) thick wood composite core with wood veneer bonded to the faces and edges.
- Glass screens are made with 0.240" (6mm) thick tempered safety glass eased on the top and sides with beveled corners at the top.

Tool Rail

The tool rail is made from extruded aluminum and can be attached to desks and storage with aluminum extruded posts. The rail supports monitor arms and plastic molded paper management accessories.

Technical Specifications – Beside Storage

Electrical Distribution System

The electrical distribution system has eight-wires and can be specified with either one 3-circuit or two different types of 4-circuit wiring configurations. The system is UL listed and CUL certified (UL Mark for Canada). The overall system is PVC Free and consists of a variety of in-feeds to bring power to desks or storage. Power distribution assemblies (PDA) and flexible power jumpers/connectors route power through the furniture. The power system has 8-wires and is available in 3 or 4 circuit configurations. The 3-circuit version has 3 hot conductors, 3 neutral conductors, 1 common ground, and 1 isolated ground. The wire gauge of the 3-circuit system's conductors is 12 American Wire Gauge (AWG). The 4-circuit has two versions; one is a 2 + 2 configuration and the other is a 3 + 1, both of which have 4 hot conductors, 2 neutral conductors, 1 common ground, and 1 isolated ground. The wire gauge of the 4-circuit system's conductors is 10 AWG for the neutral conductors and 12 AWG for the hot and ground conductors. All circuits for the 3 and 4-circuit systems are rated for 20 amps at 125 volts.

- Power Taps and Receptacles are used to access power in Desks. Vertical and horizontal oriented Power Taps can connect directly to a Power Distribution Assembly (PDA) with a modular connector, directly to an outlet using the corded version, or directly to building power using the hardwire version. The Modular connector version connects to one of six locations on a PDA. The corded version is available in four lengths and consists of a black insulated cord with a three conductor NEMA 5-15P plug for connection to a standard NEMA 5-15R receptacle. The hardwire version is available in four lengths and consists of a 3/8" flexible metal conduit with three 12 AWG conductors. Power Taps are attached using a variety of separately specified brackets. Power Taps are circuit specific and available with common ground access only. Triplex receptacles are available to access power and are unique for the 3-circuit and both 4-circuit systems. They are available in 15 Amp (NEMA 5-15R) or 20 Amp (NEMA 5-20R) configurations with either common or isolated ground access. The 3-circuit 15 Amp receptacles are programmable to all three circuits. The 3-circuit 20 Amp receptacles and all 4-circuit receptacles are circuit specific.
- Power Taps are used to access power in Storage Base Units and are available in a modular and hardwire version. Both are described above.

Jumpers consist of eight conductors which are enclosed in flexible metal conduit between two plastic enclosures. Jumpers route between PDAs and are secured with safety latches. Electrical power enters PDA's attached to desk mounted utility trays or mounted to the back utility cavity of storage units through separately specified power in-feeds. Several types of in-feeds are available and allow for connection to building power from floors, columns, or the ceiling to the power system. A hardwire electrical system is also available. The desk mounted utility tray and utility cavity of storage units allow routing of data and communication cables in addition to power.

LED Task Lights

The Stand-Alone LED Task Light has a peak output of 444 Lumens/ 76 Foot Candles at 7.8 Watts. Power cord consists of a 15 Watt 24 V transformer power supply contained in a molded plug and a 9' black cord. Fixture housing is 16.4" (417mm) long x 2" (51mm) wide x 0.5" (12 mm) high.

The Starter LED Task Lights have peak outputs of 444/980/1412/1791 Lumens, 76/131/148/151 Foot Candles, and 7.8/17.6/25.9/33.6 Watts for fixture lengths of 17" (431.8mm)/31" (787.4mm)/44" (1117.6mm)/58" (1473.2mm) respectively. Power cord consists of a 60 Watt 24 V in-line brick transformer with a 12' (304.80mm) black cord. Actual fixture housings are 30.1" (764.54mm), 43.7" (1110.0mm), or 57.4" (1458 mm) long x 2" (50.8mm) wide x 0.5" (12.7mm) high.

Add-On LED Task Lights fixtures are identical to Starter LED Light fixtures but contain a 54" (1371.6mm) black inter-link cord instead of a power cord. Add-On LED Task Lights are used in conjunction with Starter LED Task Lights to form a Daisy Chain configuration.

All LED light fixtures have a color temperature of 3500 and a CRI of 84. Lights employ a touch sensitive switch with touch-and-hold continuous dimming from 100% to 15% and single touch on/off power. An auto off feature on each fixture activates after 10 hours (+/- 15 minutes) of use. Mounting options include clips with screws for attachment to wood/laminate surfaces or clips with magnets for attachment to steel surfaces. Fixtures carry the ETL mark indicating conformance to UL 153 and certified to CAN/CSA C22.2 No. 9.

Technical Specifications – Beside Storage

LED Occupancy Sensor

A passive infrared (PIR) interlink occupancy sensor can be added to single or multiple interconnected (daisy-chained) LED Task Lights. The sensor will automatically turn off the lights after 30 minutes of no detection and back on as the user re-enters the workspace. In a daisy-chain application all fixtures connected after the sensor will be controlled. Sensor is attached to LED fixtures with either a 1" (25.4mm) long end-to-end connector or an interlink cord. Sensor is 2.3" (58.4mm) long x 2" (50.8mm) wide x 0.7" (17.78mm) high.

Electronic Ballast Task Light

Task lights have an Energy Star® rated electronic ballast. They have a T8 Task lights have an Energy Star rated electronic ballast. They have a T8 3500K Tri-Phosphor Octic lamp with low mercury content and are rated for a 20,000 hour life. Lamp wattage is 13W for 24" (762mm) wide lights, 17W for 36" (914mm) wide lights, 25W for 42" (1067mm) wide lights and 32W for 54" (1372mm) wide lights. A six foot long, black, cord with three conductor plug is factory installed on right side and may be field-installed on left side of 42" (1067mm) and 54" (1372mm) units. An optional 9' cord is available. The Chicago version has a plug with an integral 3-amp re-settable circuit breaker. Lights are standard with an acrylic lens featuring a pyramid shaped prism pattern that reduces reflected glare. An optional batwing lens consisting of a series of prisms that distributes light patterns to the left and right of the observer and further reduces reflective glare is available. Lights 42" (1067mm) wide and 54" (1372mm) wide can be specified for daisy chain applications allowing up to 5 lights to be powered by a single cord with plug. Lights are listed by Underwriters Laboratory for use in the United States and certified by UL to Canadian Standards. Task lights include mounting brackets for attaching under metal shelves and screws for attaching under countertops and wood/laminate components. The lights are concealed behind the front edge of steel shelves or by a separately specified skirt.

This page intentionally left blank.

Finish/Color Legend

Wood Finishes		Laminate		Edgeband		Trim	
Grade A		Grade A		Solid Color		Grade A	
<u>Double Cut</u>		<u>Solid Color</u>		<u>Solid Color</u>		<u>Smooth</u>	
2P-RL	Applegate	H-34	Beige	HP-34	Beige	TR-R	Beige
WL-RL	Beachwood	H-AK	Chalk	HP-AK	Chalk	TR-AK	Chalk
2R-RL	Butternut	H-8J	Charcoal	HP-8J	Charcoal	TR-K	Charcoal
WE-RD	Dune	H-3J	Graphite	HP-3J	Graphite	TR-C1	Cocoa
WJ-RE	Ebony	H-62	Gray Tone	HP-62	Gray Tone	TR-J	Graphite
2N-RL	Echo	H-WL	Linen	HP-WL	Linen	TR-G	Gray Tone
WE-RT	Melba	H-3P	Platinum	HP-3P	Platinum	TR-AA	Putty
WC-RW	Wenge	H-AA	Putty	HP-AA	Putty	TR-E	Smoke
		H-3E	Smoke	HP-3E	Smoke	TR-PLS	Smooth Plaster
						TR-FM	Snow
Grade B		Wood		Wood Grain		Textured	
<u>Anegre Quarter Cut</u>		<u>Wood</u>		<u>Wood Grain</u>		<u>Textured</u>	
NP-W15	Espresso	H-AM	Amber Cherry	HP-KA	Brazilwood	TR-TY	Cement
NP-W08	Golden	H-AE	Maple	HP-AM	Cherry	TR-TG	Grout
NP-W07	Light	H-AD	Medium Cherry	HP-KG	Columbian Walnut	TR-TF	Pitch
				HP-KP	Field Elm	TR-TW	Plaster
<u>Cherry</u>		Grade B		HP-KN	Grey Elm		
VC-CA1	Amber	<u>Premium Wood Grain</u>		HP-KM	Landmark Wood		
VC-W23	American	H-KA	Brazilwood	HP-AE	Maple		
VC-W33	Caramel	H-KG	Columbian Walnut	HP-AD	Medium Cherry		
VC-W30	Heritage	H-KP	Field Elm	HP-KL	Neo Walnut		
VC-W32	Pacific	H-KN	Grey Elm	HP-KC	New Age Oak		
		H-KM	Landmark Wood	HP-KR	Phantom Ecru		
<u>Cherry Quarter Cut</u>		H-KL	Neo Walnut	HP-KS	Phantom Pearl		
NX-U	Medium	H-KC	New Age Oak	HP-KD	River Cherry		
		H-KR	Phantom Ecru	HP-KE	Sanara		
<u>Maple</u>		H-KS	Phantom Pearl	HP-KF	Williamsburg Cherry		
VP-LM	Light	H-KD	River Cherry				
VP-N	Natural	H-KE	Sanara				
VP-AD	Sand	H-KF	Williamsburg Cherry				
<u>Maple Quarter Cut</u>							
NM-N	Natural						
<u>Oak</u>							
VJ-W42	Brindle						
VJ-W05	Natural						
<u>Rift Cut White Oak</u>							
NR-W15	Espresso						
NR-W37	Fawn						
NR-W40	Mocha						
NR-W38	Tuxedo						
<u>Walnut</u>							
VR-W15	Espresso						
VR-W31	Retro						
<u>Walnut Quarter Cut</u>							
NW-W15	Espresso						
NW-W31	Retro						
NW-W41	Verdant						

ALERT: These materials are current, however they are being considered for future obsolescence due to low volume.

Wood:

VR-W21 Mahogany Satin on Walnut
VR-W12 Naturally
WF-RC Sorrel Double Cut

Laminate:

H-DH Barley Grain
H-22 Gray Spex
H-AD Medium Cherry
H-DA Oats Grain
H-EK Owl Nest
H-EC Quail Nest
H-ED Rhea Nest
H-EA Robin Nest
H-DE Wheat Grain
H-21 White Spex

Forest Stewardship Council (FSC) Statement:

In our continuing support of sustainable forestry and responsible purchasing, Haworth North America is offering FSC certified wood products at no up-charge. By providing FSC certified material, Haworth is supporting our client's green building goals and demonstrating our collective commitment to source materials more sustainably.

Haworth will provide to you the necessary FSC-certified paperwork with your shipment. For more information, FAQs, and a complete FSC product list (including product exceptions), go to the Library and search FSC.

Smooth Metallic

TR-DM Dark Bronze Metallic
TR-MC Metallic Champagne
TR-LE Metallic Silver

Textured Metallic

TR-AL Alloy
TR-AR Argent
TR-HE Hellenic

Vertical Fabrics/Color Legend

Vertical Fabrics listed apply to Belong Screens.

• To obtain fabric samples contact your authorized Haworth dealer.

(d) = Directional fabric

(n) = Non-directional fabric

• Fabric and finish availability as well as technical information are subject to change; refer to Surfaces.Haworth.com for current information.

Fabric Grade: A (d)
**ETCH
100% Post Consumer
Recycled Polyester**

35-CM	Cameo
35-CA	Cartoon
35-CT	Circuit
35-CR	Crayon
35-DD	Doodle
35-DT	Draft
35-DR	Draw
35-MA	Marquette
35-UT	Outline
35-PA	Pastel
35-PE	Pencil
35-SP	Scratch Pad
35-SK	Sketch
35-TH	Thatch
35-TT	Tic Tac

Fabric Grade: A (d)
**HIGHLANDS
100% Recycled Polyester
(100% REPREVE®)**

L6-AG	Glen
L6-AH	Heather
L6-AL	Loch
L6-AM	Moor
L6-AP	Peat
L6-AT	Thatch

Fabric Grade: A (d)
**IOWA
52% Post Industrial
Recycled Polyester/
48% Post Consumer
Recycled Polyester**

FZ-10	Badger
FZ-6	Bixby
FZ-3	Bobwhite
FZ-2	Cedar Rock
FZ-11	Clear Lake
FZ-13	Emerson
FZ-7	Gar
FZ-9	Honeycreek
FZ-1	Manawa
FZ-5	Rice Lake
FZ-4	Trappers Bay
FZ-12	Walnut Woods
FZ-8	Wapello

Fabric Grade: A (d)
**POINT
100% Polyester**

EE-AG	Compass
EE-AC	Decimal
EE-AF	Focal
EE-AD	Nib
EE-AA	Peak
EE-AE	Vertex

Fabric Grade: A (d)
**STRIAE
42% Post Industrial
Recycled Polyester/
42% Post Consumer
Recycled Polyester/
16% Polyester
(84% REPREVE®)**

C1-AM	Band
C1-AJ	Beam
C1-AH	Element
C1-AF	Fillet
C1-AC	Moonlight
C1-AE	Ray
C1-AK	Ribbon
C1-AD	Straws
C1-AA	Stream
C1-AL	Trace

Fabric Grade A (d)
**TAILORED
100% Post Consumer
Recycled Polyester**

PY-AL	Alter
PY-BU	Buttons
PY-DR	Draper
PY-FC	French Chalk
PY-HE	Hem
PY-MA	Mannequin
PY-SE	Seam
PY-SH	Shears
PY-SU	Suit
PY-TH	Thread
PY-TR	Tradition

Fabric Grade: A (d)
**TATAMI
100% Polyester**

W5-1	Agave
W5-2	Coir
W5-3	Geta
W5-4	Hemp
W5-5	Jute
W5-6	Kayar
W5-7	Kobe
W5-8	Saffron
W5-9	Sapporo
W5-10	Sisal
W5-12	Tabi
W5-11	Tesori

Fabric Grade: A (n)
TELLURE

3A-31	Aegean
3A-18	Black
3A-45	Buff
3A-53	Cayenne
3A-40	Chocolate
3A-49	Dove
3A-28	Dynamo
3A-54	Goose
3A-23	Jodhpurs
3A-33	Miami
3A-19	Navy
3A-06	Nickel
3A-34	Ocean
3A-46	Parrot
3A-50	Peel
3A-47	Pumpkin
3A-44	Roan
3A-51	Rust
3A-37	Spring
3A-48	Sprout
3A-52	Sunset
3A-43	Tomato

Fabric Grade A (d)
**TUSCAN
65% Post Industrial
Recycled Polyester/
35% Post Consumer
Recycled Polyester
(35% REPREVE®)**

TK-AR	Arno
TK-CA	Carrara
TK-DA	David
TK-ET	Etruscan
TK-FL	Florence
TK-LM	Limoncello
TK-MA	Masonry
TK-ME	Medici
TK-TR	Olive Tree
TK-PS	Pisa
TK-RM	Romanesque
TK-RU	Rustic
TK-SE	Siena

Fabric Grade: B (d)
**CAMP
100% Post Consumer
Recycled Polyester**

33-CF	Campfire
33-CA	Canoe
33-CT	Cot
33-DK	Docks
33-FF	Firefly
33-FR	Forest
33-GR	Granola
33-GL	Grill
33-JA	Jamboree
33-PD	Pond
33-RA	Rain
33-SC	Scout
33-SM	Smore
33-TE	Tent

Fabric Grade: B (d)
**CLASSIC
82% Recycled Polyester/
18% Polyester
(82% REPREVE®)**

L5-AJ	Art
L5-AG	Car
L5-AF	Comedy
L5-AR	Dance
L5-AH	Design
L5-AD	Drama
L5-AT	Movie
L5-AA	Musical
L5-AC	Radio
L5-AS	Song

Fabric Grade: B (d)
**FIELDS
50% Post Consumer
Recycled Polyester/
50% Virgin Polyester**

34-AL	Alfalfa
34-BB	Blueberry
34-CN	Corn
34-CT	Cotton
34-OA	Oats
34-PL	Plow
34-PR	Prairie
34-PK	Pumpkin
34-SC	Scarecrow
34-SY	Soy
34-ST	Strawberry
34-TL	Till
34-WH	Wheat

Fabric Grade: B (d)
**HUE
62% Antimony Free Polyester/
38% Virgin Polyester**

6-BK	Bark
6-ED	Eddy
6-FR	Froth
6-GK	Ginko
6-LT	Latte
6-LF	Leaf
6-LM	Lemon
6-MG	Marigold
6-MR	Marine
6-PP	Poppy
6-RD	Red
6-SS	Seaside
6-SP	Spring
6-ST	Steam
6-TQ	Turquoise
6-WP	Wisp

Fabric Grade: B (d)
**KIO
100% Recycled Polyester**

ZR-6	Bennett
ZR-8	Cascade
ZR-7	Crew
ZR-5	FUD
ZR-3	Jeanlin
ZR-1	Jib
ZR-11	Reeds Lake
ZR-13	Regatta
ZR-10	Sailor
ZR-2	Sentra
ZR-12	Smurf
ZR-9	TSJ
ZR-4	Yippi Kio

Vertical Fabrics/Color Legend

Fabric Grade: B (d)
PECA
**51% Virgin Polyester/
49% Antimony Free
Polyester**

32-BE	Bead
32-CH	Chip
32-DT	Dots
32-EL	Elfin
32-JT	Jot
32-MN	Minnow
32-MS	Mouse
32-PW	Pee Wee
32-SE	Seed
32-SM	Smidge
32-TA	Tad
32-TT	Title
32-TR	Trifle
32-TY	Tyne

Fabric Grade: B (n)
PUZZLER
**48% Post Industrial
Recycled Polyester/
52% Post Consumer
Recycled Polyester**

7L-C	Clue
7L-CR	Cryptic
7L-E	Enigma
7L-I	Intrigue
7L-M	Maze
7L-R	Riddle

Fabric Grade: B (d)
REVERB
**100% Post Consumer
Recycled Polyester**

3V-BM	Boomy
3V-BN	Bounce
3V-CR	Crackle
3V-EC	Echo
3V-GN	Gong
3V-HA	Harmonics
3V-MG	Moog
3V-MR	Murmur
3V-PN	Ping
3V-RF	Rifts
3V-RN	Ring
3V-SN	Snare
3V-SC	Sonic
3V-SY	Synth
3V-TM	Timbers
3V-WF	Waft

Fabric Grade B (d)
RITZ
**49% Post Industrial
Recycled Polyester/
51% Post Consumer
Recycled Polyester
(51% REPPEVE')**

PV-BR	Bravo
PV-BT	Black Tie
PV-CA	Candle Light
PV-CH	Champagne
PV-CL	Classy
PV-CT	Class Act
PV-FR	Formal
PV-VA	Ovation
PV-WT	White Tie

Fabric Grade: B (d)
SHIMMER
100% Recycled Polyester

WS-5	Cellophane
WS-8	Copper
WS-13	Dew
WS-14	Diamond
WS-9	Flaxen
WS-4	Gems
WS-11	Glass
WS-1	Glitter
WS-10	Mirage
WS-16	Mirror
WS-2	Moonlight
WS-6	Puddle
WS-15	Reflection
WS-12	Stars
WS-3	Water
WS-7	Wet Grass

Fabric Grade: B (d)
TRAFFIC
**24% Post Industrial
Recycled Polyester/
76% Post Consumer
Recycled Polyester**

WZ-9	Autobon
WZ-6	Country Drive
WZ-7	Freeway
WZ-5	Gridlock
WZ-1	Jam
WZ-3	Merge
WZ-8	Route 66
WZ-4	Ticket
WZ-2	Yield

Fabric Grade C (d)
BIRDS NEST
**38% Post Industrial
Recycled Polyester/
20% Post Consumer
Recycled Polyester/
42% Recycled Polyester
(20% REPPEVE')**

PH-CA	Canary
PH-EA	Eagle
PH-EG	Egret
PH-FA	Falcon
PH-HE	Heron
PH-HU	Hummingbird
PH-MD	Morning Dove
PH-NU	Nuthatch
PH-WL	Owl
PH-RA	Raven
PH-SA	Sandpiper
PH-ST	Stork
PH-SW	Swan

Fabric Grade C (d)
GEODE
**34% Post Industrial
Recycled Polyester/
26% Post Consumer
Recycled Polyester/
40% Recycled Polyester
(26% REPPEVE')**

PR-BS	Bismuth
PR-CA	Calcite
PR-CT	Citrine
PR-CR	Crystal
PR-FL	Fluorite
PR-GA	Galena
PR-HL	Hollow
PR-MA	Malachite
PR-QU	Quartz
PR-WN	Wonder

Fabric Grade: C (d)
THORMAN
**48% Post Industrial
Recycled Polyester/
26% Post Consumer
Recycled 26% Polyester**

45-DR	Dryden
45-EC	Eclipse
45-FR	Farm
45-FL	Flamingo
45-HS	Hope St
45-KV	Kevin
45-MR	Martini
45-SM	Sam
45-TH	Theatre

Fabric Grade: D (d)
TANGRAM
**57% Polyester/
28% Post Industrial
Recycled Polyester/
15% Post Consumer
Recycled Polyester**

LV-CL	Clue
LV-EN	Enigma
LV-GU	Guess
LV-MA	Maze
LV-MU	Muse
LV-MT	Mystery
LV-MY	Mystify
LV-UT	Outline
LV-PE	Perplex
LV-PC	Pieces
LV-PU	Puzzle
LV-RD	Riddle
LV-SC	Scrabble
LV-SL	Solve
LV-TE	Teaser
LV-TR	Trick

ALERT: These materials are current, however they are being considered for future obsolescence due to low volume.

Fabric Grade: A (d)
SAVOY
**51% Virgin Polyester/
49% Recycled Polyester**

FJ-CC	Apache
FJ-AD	Balsam
FJ-AP	Bisque
FJ-AE	Blue Ridge
FJ-AA	Blue Willow
FJ-CA	Breaker
FJ-AR	Chamois
FJ-AK	Elephant
FJ-AL	Glacier
FJ-AX	Mango
FJ-AY	Maya
FJ-AW	Poplar
FJ-CD	Raisen
FJ-AT	Shallot
FJ-AM	Stainless
FJ-AF	Tempest

Fabric Grade: B (d)
LANDSCAPE
100% Recycled Polyester

C2-AD	Estate
C2-AH	Harvest
C2-AJ	Panorama
C2-AF	Parkland
C2-AC	Photograph
C2-AE	Seascape
C2-AA	Vista

Haworth+

For information on the Haworth+ alliance program, including images and product availability, please refer to: Surfaces.Haworth.com

Customer's Own Material (COM)

For general Customer's Own Material (COM) information including processes and forms, please refer to: surfaces.haworth.com > Resources > COM

For information on approved COM's, please refer to: surfaces.haworth.com > COM Library

Seating Fabrics/Color Legend

- The following fabrics are available on Seating and cushions.

(d) = Directional fabric (n) = Non-directional fabric

- To obtain fabric samples contact your authorized Haworth dealer.
- Fabric and finish availability as well as technical information are subject to change; refer to Surfaces.Haworth.com for current information.

Fabric Grade: A (d)
BLANKET
50% Post Consumer Recycled Polyester, 50% Virgin Polyester

4H-BE Beach
 4H-BD Bindle
 4H-CL Cloak
 4H-FE Feather
 4H-FW Firewheel
 4H-FT Fort
 4H-GR Grass
 4H-HD Hood
 4H-MA Mackinaw
 4H-MT Manta
 4H-PN Picnic
 4H-PC Poncho
 4H-SW Swag
 4H-SP Sweep
 4H-TK Tuck
 4H-YA Yawn

Fabric Grade: A (d)
HORIZON

100% Polyester
 1N-001 Beeline
 1N-004 Birdseye
 1N-003 Border
 1N-002 Compass
 1N-005 Panorama
 1N-008 Skyline
 1N-006 Sweep
 1N-007 Vista

Fabric Grade: A (d)
MORSE

100% Polyester
 4J-BP Blip
 4J-CA Cable
 4J-CD Code
 4J-DA Dash
 4J-DT Dot
 4J-MA Marconi
 4J-RA Radio
 4J-SS S.O.S.
 4J-SC Scribe
 4J-TA Tap
 4J-TE Telegraph
 4J-TR Transmit
 4J-WL Wireless

Fabric Grade: A (d)
PIXEL
51% Polyester, 32% Post Industrial Recycled Polyester, 17% Post Consumer Recycled Polyester

2A-BY Byte
 2A-DC Dice
 2A-DT Dot
 2A-EA Easel
 2A-FT Flaunt
 2A-FC Focus
 2A-FL Folio
 2A-HM Home
 2A-IK Ikon
 2A-IM Imagine
 2A-ND Node
 2A-PM Pomp
 2A-RA Raster
 2A-SP Spectral
 2A-TA Tab
 2A-VE Vertex

Fabric Grade: A (n)
TELLURE
100% Polyester

3A-31 Aegean
 3A-18 Black
 3A-45 Buff
 3A-53 Cayenne
 3A-40 Chocolate
 3A-49 Dove
 3A-28 Dynamo
 3A-54 Goose
 3A-23 Jodhpurs
 3A-33 Miami
 3A-19 Navy
 3A-06 Nickel
 3A-34 Ocean
 3A-46 Parrot
 3A-50 Peel
 3A-47 Pumpkin
 3A-44 Roan
 3A-51 Rust
 3A-37 Spring
 3A-48 Sprout
 3A-52 Sunset
 3A-43 Tomato

Fabric Grade: A (d)
TWIST

80% Post Consumer Recycled Polyester, 20% from Rayon Bamboo
 MM-AS And Shout
 MM-C Coil
 MM-CS Corkscrew
 MM-CU Curl
 MM-D DNA
 MM-I Ivy
 MM-P Plot
 MM-SW Sidewinder
 MM-S Snail
 MM-SP Spire
 MM-WH Whirlpool
 MM-W Winding

Fabric Grade: A (n)
WELLINGTON FAUX LEATHER

100% Polyurethane
 XJ-BL Black
 XJ-BU Buff
 XJ-EL Elephant
 XJ-JA Java
 XJ-PA Pacific
 XJ-SA Sage
 XJ-ST Storm
 XJ-TA Tangelo
 XJ-WI Wine

Fabric Grade: B (d)
ALIGN
97% Post Industrial Recycled Nylon, 3% Post Consumer Recycled Nylon

4F-AR Array
 4F-FC Focus
 4F-LM Limerick
 4F-OR Orient
 4F-PK Picket
 4F-RT Root
 4F-SC Scrimmage
 4F-SP Spring
 4F-TA Tangent
 4F-TL Tree Line
 4F-WR Wire

Fabric Grade: B (d)
DIAGONALE

16% Nylon, 84% Polyester
 4N-AC Across
 4N-BA Bias
 4N-CH Chevron
 4N-CR Crosscut
 4N-DA Diamond
 4N-FE Featherstitch
 4N-HT Half Timber
 4N-KC Kitty Corner
 4N-MA Matrix
 4N-OB Oblique
 4N-SE Serge
 4N-ST Slant
 4N-SH Slash
 4N-SL Slope
 4N-WC Whipcord
 4N-ZZ Zig Zag

Fabric Grade: B (d)
ENGLISH TWEED
92% Polyester, 5% Post Industrial Recycled Polyester, 3% Post Consumer Recycled Polyester

4E-B5 Biscuit
 4E-BL Blimey
 4E-BN Bonnet
 4E-CT Cottage
 4E-DW Doctor Who
 4E-FX Fox
 4E-ML My Lady
 4E-XD Oxford
 4E-PE Pipe
 4E-SH Sherry
 4E-SN Stilton
 4E-ST Stout
 4E-TE Tea
 4E-TU Tudor

Fabric Grade: B (d)
JEWEL
77% Post Industrial Recycled Polyester, 23% Post Consumer Recycled Polyester

MN-AM Amber
 MN-A Aquamarine
 MN-C Citrine
 MN-E Emerald
 MN-G Garnet
 MN-J Jade
 MN-M Malachite
 MN-R Ruby
 MN-S Sapphire
 MN-TE Tiger's Eye

Fabric Grade: B (d)
LEEF

49% Post Industrial Recycled Polyester 51% Post Consumer Recycled Polyester

ML-A Aspen
 ML-B Beet
 ML-C Coca
 ML-CN Coconut
 ML-F Fennel
 ML-HE Henna
 ML-H Hosta
 ML-HY Hydrangea
 ML-M Moonflower
 ML-PE Petunia
 ML-P Pumpkin
 ML-S Sunflower
 ML-V Violet

Fabric Grade: B (d)
MOODRING

100% Recycled Polyester
 NQ-4 Calm
 NQ-24 Cheerful
 NQ-3 Cool
 NQ-21 Grounded
 NQ-25 Happy
 NQ-22 Inspired
 NQ-23 Intense
 NQ-8 Joy
 NQ-10 Liberate
 NQ-28 Peaceful
 NQ-26 Restful
 NQ-27 Zen

Fabric Grade: B (d)
RAMIE
62% Polyester, 25% Post Industrial Recycled Polyester, 13% Post Consumer Recycled Polyester

4V-B5 Basket
 4V-BT Bast
 4V-FX Foxtail
 4V-GN Gunnie
 4V-HY Hay
 4V-MC Macrame
 4V-ML Millet
 4V-MB Mulberry
 4V-RN Rain
 4V-RD Reed
 4V-RT Root
 4V-SC Sack Cloth
 4V-SS Sisal
 4V-TH Thatch
 4V-WT Water
 4V-WD Weed

Fabric Grade: B (d)
TECH

100% Post Consumer Recycled Polyester
 MV-A1 A.I.
 MV-AN Anatomy
 MV-A Aviation
 MV-B Bionics
 MV-C Cosmos
 MV-D Disc
 MV-E Electric
 MV-F Forestry
 MV-L Logic
 MV-P Optics
 MV-RA Radio
 MV-R Rocket
 MV-SF Sci-Fi
 MV-S Skill
 MV-T Theory
 MV-Z Zoology

Fabric Grade: C (d)
KING

100% Polyester
 LH-BE Beige
 LH-DB Dark Blue
 LH-DG Dark Green
 LH-DM Dark Mustard
 LH-GD Gold
 LH-GL Light Green
 LH-LG Light Grey
 LH-MB Medium Blue
 LH-MG Medium Grey
 LH-RD Red
 LH-RG Orange
 LH-WG Warm Grey

Fabric Grade: C (d)
MAYA

100% Polyester
 LM-DB Dark Blue
 LM-GR Green
 LM-GY Golden Yellow
 LM-MG Medium Cool Grey
 LM-WG Medium Warm Grey
 LM-RG Orange

Seating Fabrics/Color Legend

Fabric Grade: C (d)

SMALL ARROW
46% Virgin Nylon,
54% Post Industrial
Recycled Nylon
 4L-AR Archer
 4L-BA Barb
 4L-CR Crossbow
 4L-DA Dart
 4L-FL Fletcher
 4L-MA Mark
 4L-NK Nock
 4L-QU Quiver
 4L-RE Reed
 4L-RL Release
 4L-ST Shaft
 4L-SH Sharp
 4L-TA Target

Fabric Grade: D (d)

BIG ARROW
100% Post Consumer
Recycled Polyester
 4D-BS Bisque
 4D-BL Blue
 4D-CN Cool Neutral
 4D-DB Dark Blue
 4D-GD Gold
 4D-GR Green
 4D-MG Medium Grey
 4D-RE Red
 4D-SA Salmon
 4D-WN Warm Neutral

Fabric Grade: D (d)**BIG DIAGONALE**

66% Post Consumer
Recycled Polyester
34% Post Industrial
Recycled Polyester
 1K-AM Amber
 1K-BL Balsam
 1K-CR Carbon
 1K-ER Earth
 1K-HN Henna
 1K-MN Mineral
 1K-PR Parrot
 1K-RD Red
 1K-RS Rosa
 1K-SE Sea
 1K-TR Terracotta
 1K-ZF Zaffer

Fabric Grade: D (d)**CLASS**

100% Polyester
 LE-DG Dark Grey
 LE-GM Green Multi
 LE-GR Green
 LE-LN Light Cool Neutral
 LE-MB Medium Blue
 LE-MN Medium Warm Neutral
 LE-RR Reddish Orange

Fabric Grade D (n)

COTSWOLD
100% Wool
 JB-AN Anquilla
 JB-BR Bottlegrass
 JB-CA Camp
 JB-DN Dandelion
 JB-ED Editor Blue
 JB-GS Goldfish
 JB-HA Heart
 JB-KE Kokanee
 JB-NE Nettle Bellflower
 JB-PL Pickeral Weed
 JB-SA Sand
 JB-SD Silver Dollar
 JB-SU Silverbush
 JB-SC Soft Charcoal
 JB-TR Tree
 JB-WE Wheaton

Fabric Grade: D (d)

DOTS
72.7% Post Consumer
Recycled Polyester
27.3% Post Industrial
Recycled Nylon
 6K-CL Clay
 6K-VY Ivy
 6K-LM Lemon
 6K-MN Mandarin
 6K-MS Mist
 6K-NG Night
 6K-SH Shadow
 6K-WT Water

Fabric Grade: D (d)**ELEMENT**

76% Post Consumer
Recycled Polyester
24% Rayon
 4Z-ER Earth
 4Z-ES Essence
 4Z-FR Fire
 4Z-FS Fossil
 4Z-HR Herbal
 4Z-LG Logic
 4Z-LY Lyrical
 4Z-PL Pillar
 4Z-PT Poetic
 4Z-RR Rare
 4Z-RT Root
 4Z-SC Scenic
 4Z-TH Thread
 4Z-TM Timeless
 4Z-TR Truth
 4Z-WN Wind

Fabric Grade: D (d)**MAIN LINE FLAX**
70% Virgin Wood
30% Flax

6M-AL Aldgate
 6M-AR Archway
 6M-BN Bank
 6M-BY Bayswater
 6M-BT Bethnal
 6M-BR Brompton
 6M-CM Camden
 6M-GL Goldhawk
 6M-LM Lambeth
 6M-LY Leyton
 6M-MN Monument
 6M-ST Stanmore
 6M-TM Temple
 6M-TW Tower
 6M-TF Tufnell
 6M-WS Westminster

Fabric Grade: D (d)**NOTABLE**

28% Virgin Nylon,
72% Post Industrial
Recycled Nylon
 4K-BR Bravo
 4K-CT Concert
 4K-DR Dramatic
 4K-EN Entertain
 4K-MA Magic
 4K-MT Matinee
 4K-PA Pantomime
 4K-PE Perform
 4K-PL Play
 4K-PT Plot
 4K-PR Practice
 4K-SC Script
 4K-SH Show
 4K-SK Skit
 4K-ST Star
 4K-TH Theatrical

Fabric Grade: D (d)**TANGRAM**

57% Polyester,
28% Post Industrial
Recycled Polyester,
15% Post Consumer
Recycled Polyester
(43% REPVEVE)
 LV-CL Clue
 LV-EN Enigma
 LV-GU Guess
 LV-MA Maze
 LV-MU Muse
 LV-MT Mystery
 LV-MY Mystify
 LV-UT Outline
 LV-PE Perplex
 LV-PC Pieces
 LV-PU Puzzle
 LV-RD Riddle
 LV-SC Scrabble
 LV-SL Solve
 LV-TE Teaser
 LV-TR Trick

Fabric Grade: E (d)**BRISA FAUX LEATHER**
100% Polyurethane face,
65% Polyester,
35% Rayon Backing

XG-23 Apple Green
 XG-22 Ash
 XG-3 Aztec
 XG-28 Birch
 XG-12 Black Onyx
 XG-25 Blossom
 XG-5 Cambridge Blue
 XG-26 Coffee Bean
 XG-20 New Sand
 XG-18 Night Navy
 XG-21 Pompeian Red
 XG-1 Salsa
 XG-27 Shitake
 XG-24 Skyway
 XG-17 Sterling Blue
 XG-13 White

ALERT: These materials are current, however they are being considered for future obsolescence due to low volume.

Fabric Grade: A (d)

BARQUE
69% Polyester,
31% Recycled Polyester
(31% REPVEVE)
 07-AH Ash
 07-AS Aspen
 07-BR Birch
 07-BW Black Walnut
 07-CN Chestnut
 07-GO Golden Oak
 07-RB Redbud
 07-WL Willow

Fabric Grade: A (d)

DOTTIE
89% Post Industrial
Recycled Polyester,
11% Post Consumer
Recycled Polyester
 ME-CA Calico
 ME-C Chads
 ME-DD Dew Drops
 ME-F Flecks
 ME-M Morse
 ME-P Pip
 ME-PD Polka Dots
 ME-R Roulette
 ME-T Tabby
 ME-Y Yahtzee

Fabric Grade: A (d)

GAUGE
100% Recycled Polyester
 1X-05 Depth
 1X-04 Gas
 1X-11 Narrow
 1X-08 Pressure
 1X-02 Rain
 1X-12 Sea
 1X-13 Standard
 1X-10 Test
 1X-03 Time
 1X-09 Water
 1X-06 Weather
 1X-01 Wind
 1X-07 Wire

Haworth+

For information on the Haworth+ alliance program, including images and product availability, please refer to:
surfaces.haworth.com > Haworth+ Library

Customer's Own Material (COM)

For general Customer's Own Material (COM) information including processes and forms, please refer to:
surfaces.haworth.com > Resources > COM
 For information on approved COM's, please refer to:
surfaces.haworth.com > COM Library

Fabric Grade: A (d)

ZINGER
37% Recycled Polyester,
63% Polyester
(13% REPVEVE)
 NI-2 BBQ
 NI-17 Beluga
 NI-10 Bluegill
 NI-8 Chips
 NI-11 Classic
 NI-16 Concord
 NI-13 Frog
 NI-15 Glade
 NI-9 Grain
 NI-12 Granny
 NI-4 Gravel
 NI-18 Kiwi
 NI-20 Mulberry
 NI-3 Onion
 NI-6 Pacific
 NI-1 Roan
 NI-21 Tar
 NI-7 Wagon
 NI-19 Wicker
 NI-5 Wolf

Fabric Grade: B (d)

COCKTAIL
100% Eco-Intelligent*
Polyester
MBDC Cradle to Cradle Gold
 1W-12 Black Cow
 1W-08 Blue Moon
 1W-13 Boilermaker
 1W-01 Bubbly
 1W-03 Gibson
 1W-04 Grasshopper
 1W-07 Lounge
 1W-16 Margarita
 1W-10 Martini
 1W-14 Mojito
 1W-11 Old Fashion
 1W-06 Pink Squirrel
 1W-15 Sidecar
 1W-09 Stinger
 1W-02 Stout
 1W-05 Swizzle

COM Yardage Requirements

Procedure

To confirm approval of or request new approval for COM's, contact the **Haworth Inquiry Center (1.800.426.8562)**, or <http://hub.Haworth.com>, or www.haworth.com > **surface collection** > **COM Library** to determine if the COM you have selected has already been tested and approved for use on our product.

If the fabric is approved, and the directional orientation (directional rightway, directional railroad, or non-directional) of the tested fabric has been confirmed, then refer to the appropriate column in the chart for yardage requirements.

Steps to follow to calculate fabric usage:

- 1) Identify product type and size.
- 2) Determine method in which fabric is to be cut (directional rightway, directional railroad or non-directional).
- 3) Determine fabric roll width.
- 4) Find corresponding fabric usage value from the table.
- 5) Calculate fabric required using the formula below:

$$\text{Fabric usage} = \text{number of units} \times \text{number of sides with fabric} \times \text{fabric usage (from tables)} + C \text{ (constant).}$$

Constant — Compose[®], PREMISE[®], PLACES[®] and UniGroup[®]

Product	C
Panels	2.5
Tackboards, Tackstrips	1.5
OSUs and Flipper Doors	1.5
LFBs and VSUs	1.5
Trim Covers (Finish Post, End of Run)	1.5
Stackable Pads	1.5
Add-ons and Wainscot Panels	1.5

Constant — RACE[®]

Product	C
Desktop Screens	1.5
RACE Privacy Screens*	0.0
RACE Pads	0.0

*Includes fabric for both sides. Sizes 51"-78" include two screens.

- 6) Repeat steps 1-5 for each product type, size and fabric.
- 7) Add all values together to find total number of linear yards required for the order. Add the appropriate percentage shown below to the total yardage to accommodate fabric flaws, wrinkles and other imperfections.

Up to 500 yards	Add 10%
501 to 1000 yards	Add 5%
More than 1000 yards	Add 3%

Directional Rightway:

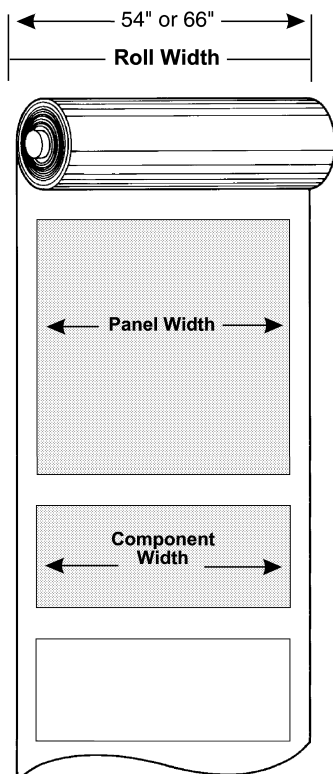

Directional Railroad:

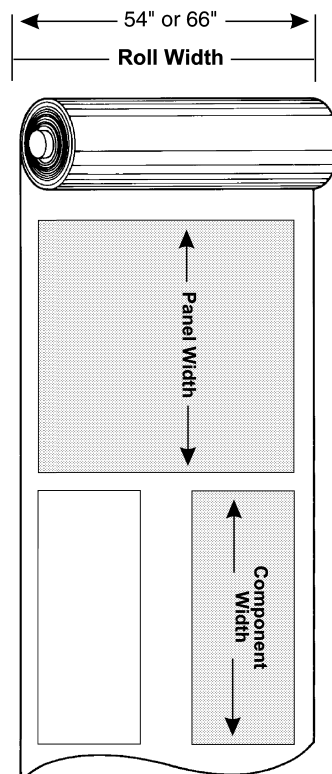

Non-Directional:

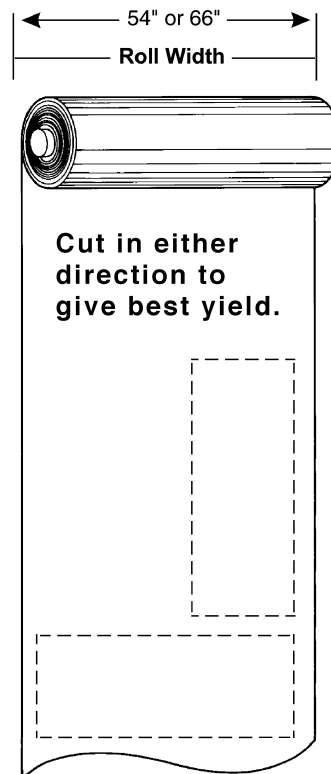

COM Yardage Requirements

Nominal (Inches)		66 Inch Roll (Linear Yards)			54 Inch Roll (Linear Yards)		
Height	Width	Directional	Railroad	Non-directional	Directional	Railroad	Non-directional
BELONG Back, End, Center Screen Fabric Usage							
14" (356mm)	24" (610mm)	0.250	0.259	0.250	0.500	0.259	0.259
	30" (762mm)	0.500	0.315	0.315	0.500	0.315	0.315
	36" (914mm)	0.500	0.370	0.370	0.500	0.370	0.370
	42" (1067mm)	0.500	0.426	0.426	0.500	0.426	0.426
	48" (1219mm)	0.500	0.481	0.481	0.500	0.481	0.481
	54" (1372mm)	0.500	0.537	0.500	N/A	0.537	N/A
	60" (1524mm)	0.500	0.593	0.500	N/A	0.593	N/A
19" (483mm)	24" (610mm)	0.319	0.389	0.319	0.639	0.389	0.389
	30" (762mm)	0.639	0.472	0.472	0.639	0.472	0.472
	36" (914mm)	0.639	0.556	0.556	0.639	0.556	0.556
	42" (1067mm)	0.639	0.639	0.639	0.639	0.639	0.639
	48" (1219mm)	0.639	0.722	0.639	0.639	0.722	0.639
	54" (1372mm)	0.639	0.806	0.639	N/A	0.806	0.806
	60" (1524mm)	0.639	0.889	0.639	N/A	0.889	0.889
27" (686mm)	24" (610mm)	0.431	0.389	0.389	0.861	0.778	0.778
	30" (762mm)	0.861	0.472	0.472	0.861	0.944	0.861
	36" (914mm)	0.861	0.556	0.556	0.861	1.111	0.861
	42" (1067mm)	0.861	0.639	0.639	0.861	1.278	0.861
	48" (1219mm)	0.861	0.722	0.722	0.861	1.444	0.861
	54" (1372mm)	0.861	0.806	0.806	N/A	1.611	1.611
	60" (1524mm)	0.861	0.889	0.861	N/A	1.778	1.778

North American Terms of Sale

These Terms of Sale are part of a quotation, bid response, or other sales document issued by Haworth, Inc., Haworth, Ltd. ("Haworth").

These Terms of Sale do not cover products manufactured in North America shipping to non-North American countries nor do they cover products manufactured in non-North American countries shipping to North America. For those terms of sale, please contact Haworth's Global Trade and Compliance Department at 616.393.3000 or through Haworth.com.

A. Ordering Information

Haworth sells its products on the terms set forth in these standard Terms of Sale:

ORDERS MUST BE SUBMITTED IN WRITING OR ELECTRONICALLY (Lynx) AS REPRESENTED BY A VALID PURCHASE ORDER, WHICH INCLUDES PRODUCT TOTAL.

An order is not binding upon Haworth until Haworth issues an order acknowledgment to the customer (the "Customer"), which will include price information and an anticipated delivery date.

1. Order Changes/Cancellations

For Specials, Customer's Own Material (C.O.M.), finish matches, custom colors, custom products, Master lock and key orders, and RUSH orders, no changes or cancellations are allowed 24 hours after order placement. All other products require approval for changes or cancellations. A change/cancellation fee may apply. Contact Order Services for applicable charges.

Ship-to addresses changed within five (5) business days of delivery will incur fees to cover administrative costs due to re-labeling of product and/or reconsignment fees with the carrier.

Order cancellations are complete annulments of orders. Order changes are the deletion of line items or a change in size, color, quantity, ship-to address, or scope of work. There is no penalty for additions; however, any change may cause the order or the line items affected to be rescheduled. Order changes involving additional product and services which increase the value must be accompanied by an amended Purchase Order or other document as agreed.

ALL CHANGES MUST BE IN WRITING, REGARDLESS OF THE (DOLLAR) VALUE. CHANGES ARE NOT BINDING UPON HAWORTH UNTIL HAWORTH ISSUES AN ACKNOWLEDGMENT OF THE CHANGE.

2. C.O.M. (Customer's Own Material)

A Customer who requests a fabric, surface or finish material (C.O.M.) not in Haworth's standard finish offering must first confirm approval of or request new approval for the C.O.M.

Haworth will determine feasibility of the material for manufacturability. For a description of the procedure to submit C.O.M. samples, contact Haworth's Order Services department. For testing information, see the C.O.M. section of the catalog, or call Haworth Order Services.

If Haworth agrees to use the C.O.M., (1) Haworth shall have no responsibility for the condition, quality, value, performance, physical properties, or any other aspect of the C.O.M.; and (2) Haworth shall have no liability for any damages, injuries, or losses to the Customer or to any third party that shall be caused by any C.O.M., and the Customer shall hold Haworth harmless for all such liability.

3. Valid/Complete Purchase Order

The following information is required in order to process an order with Haworth:

a. Customer Information

- i. **Sold To:** Legal name, complete address (if Haworth is to bill the end user, provide end user Purchase Order made out to Haworth, Inc., Haworth, Ltd.) and phone and fax number.
- ii. **Ship To:** Legal name and address.
- iii. **Purchase Order Number:** From the party Haworth will be billing.
- iv. **Authorized Signature:** All Purchase Orders must be signed by a duly authorized representative if a signature line is present. Electronically transmitted Purchase Orders will be accepted without a signature if dealer billed and the dealer has an electronic purchase payment agreement on file.
- v. **Contact Name and Phone Number:** Person Haworth should contact with any questions regarding the order.
- vi. **Shipping Contact:** Name and phone number of person to be contacted regarding shipping and delivery matters.
- vii. **Tagging Instructions:** This information will appear on all documentation received from Haworth including: cartons, acknowledgments, and invoices.
- viii. **Price Agreement or National Sales Agreement Number**
- ix. **Product Total:** Net dollars.
- x. **Installation, Design, Project Management, and/or Service Fees**

b. Product Information

- i. **Quantity**
- ii. **Product Numbers**
- iii. **Colors**
- iv. **Specials:** Specify special part number for new special products.
- v. **Customer's Own Material:** Order entry code, manufacturer, pattern, and color.

- vi. **Approval Drawings:** An authorized signature by a duly authorized representative is required for shop drawings when applicable.
- vii. A deposit may be required for custom materials.

c. Order Confirmation

All orders will be acknowledged.

B. Pricing Policies

1. Terms of Payment

Terms of payment and credit limits will be established based on financial information. Standard payment terms on open credit are net thirty (30) days from invoice date. Advance payments or other payment security may be required by Haworth. The account balance must be at or below the credit limit and current at all times (no past-due balances). Haworth reserves the right to delay or cancel any delivery to a Customer whose Haworth account balance is over the credit limit and/or past due. For walls and floors a deposit will be required.

2. Terms of Credit

Customer hereby authorizes Haworth to obtain such credit reports, financial information or other information as Haworth may request, including, without limitation, credit information from any financial institutions or others having a business relationship with the Customer. Customer hereby authorizes any credit references to answer Haworth's inquiries and provide such credit information and documentation as Haworth may request.

The Customer hereby releases and holds Haworth harmless for any inconvenience whatsoever, caused by any temporary or permanent withdrawal or restriction of credit privileges hereunder, or the enforcement of any of the provisions contained in this paragraph.

3. Past-Due Charges

Past-due balances will be increased by a maximum of 1.5% per month, or 18% annually, without forfeit of Haworth's right to immediate payment.

4. Applicable Prices

The price of any product sold to Customer by Haworth will be based upon the North American Price List (Catalog).

Prices and discounts are subject to change without notice or approval. In the event of an adjustment to pricing, National Sales Agreement (NSA) Customers will be notified in advance according to the terms of the NSA.

Applicable prices and currency exchange rates are those in effect at the time of the RECEIPT of an ORDER; Haworth reserves the right to use the published pricing effective at the time of shipment, if the requested delivery date is more than 120 days after the order receipt date.

North American Terms of Sale

Haworth Flooring products are sold using the North American price list in US dollars. Currency exchange rates at the time of the transaction will be used to convert the USD amount into the alternate currency. Should the currency exchange rate between the USD and alternate currency change between a quote and the receipt of an order, the alternate currency amount will also change to equal the current, equivalent USD amount.

5. C.O.M. (Customer's Own Material) Charges

Refer to appropriate Customer's Own Material (C.O.M.) form for applicable surface material charges.

6. Taxes

Haworth prices do not include customs duty, sales, use, value added or similar taxes. Any federal, state/provincial or other taxes or assessments based upon the sale or delivery of products or services sold applicable to the customer at present or later imposed by federal, state/provincial or municipal agencies, shall be added and paid by the customer. Customer is responsible for all such taxes.

NOTE: For all countries a valid sales tax exemption certificate must be approved by and on file with Haworth prior to product shipment. Otherwise, sales tax will be due and payable to Haworth when such tax is invoiced to Customer.

7. Services

If, as a result of Customer request, the Haworth dealer or Haworth subsidiary provides planning/design services, storage, project management, special handling, set-up, installation and/or other services, the Customer will be charged at the local Haworth dealer/subsidiary's prevailing rates.

8. Termination by Haworth

Haworth may immediately terminate an order upon written notice in the event bankruptcy or insolvency proceedings are instituted by or against the Customer, or the Customer is adjudicated as bankrupt, becomes insolvent, makes an assignment for the benefit of creditors, or proposes or makes any arrangements for the liquidation of its debts, or a receiver or receiver and manager is appointed with respect to all or any part of the assets of the Customer.

C. Shipping and Delivery

Haworth will have the right to determine the method of shipment and routing of product.

This section does not apply to any of Haworth's Flooring products. All Haworth Flooring products are sold freight collect.

If, for any reason, a delivery has to be made to an intermediate location (i.e. a location other than the "Ship To" location noted on the order or ultimate end user location), all handling and re-delivery costs incurred would be at the Customer's expense.

1. U.S.A. - Contiguous

All deliveries will be CPT (Carriage Paid To) (ICC Incoterms 2010) Haworth's manufacturing facilities or distribution centers. Freight charges will be prepaid by Haworth on all orders to locations within the continental United States. Customer bears all risk of loss or damage to the goods when they are placed on Haworth's means of transport.

2. U.S.A. - Non-contiguous (Alaska, Hawaii and Puerto Rico)

All deliveries will be CIF (Cost, Insurance and Freight) (ICC Incoterms 2010). Haworth's catalog prices include ocean freight and insurance to the port of the final destination. Haworth has the right to determine the carrier, method of shipment and routing. Haworth will contract with the insurer and provide minimal insurance coverage (CIF @ 110%) made payable to the Customer. Customer is responsible to obtain greater insurance if so desired.

Customer bears all risk of loss or damage to the goods when the goods are effectively at the disposal of the Customer on board the vessel at the named port of destination. Proof of delivery is a clean on board bill of lading. Customer will be responsible for all on-carriage from the receiving port to the final destination.

3. Canada

All deliveries will be DDP (Delivered Duty Paid) (ICC Incoterms 2010). Haworth's catalog prices include delivery to Customer's named place, not unloaded from any arriving means of transport. Customer bears all risk of loss or damage to the goods when they are delivered to the Customer's named facility not unloaded. Haworth will assume responsibility to file all freight claims with the carrier for any loss/damage which may occur while product is in transit, and will promptly repair or replace any damaged or lost product. Haworth requires the Customer to report all freight damage and/or loss to both the carrier and to Haworth.

NOTE: Under all delivery terms (U.S.A. and Canada), any additional expense resulting from Customer's request for expedited transportation, special services, packaging, handling, routing, and/or shipping method will be billed to Customer.

4. Mexico

All deliveries will be DAP (Delivered to Place) (ICC Incoterms 2010). Haworth's catalog prices include freight charges for normal surface transportation to a United States point of exportation within the 48

contiguous states. Haworth has the right to determine the carrier, method of shipment and routing.

Customer bears all risk of loss or damage to the goods when the goods are delivered to the named United States point of exportation. Haworth will provide customs clearance facilitation and arrangement of local delivery through an Authorized Dealer in Mexico, on a separately negotiated basis. Otherwise the Customer will be responsible for all customs clearance formalities and on-carriage from the United States point of exportation to the final destination in Mexico.

5. Delivery Dates and Delay

If Haworth cannot deliver products as scheduled due to causes beyond its reasonable control (such as casualty, labor disputes, or accident; inability to obtain necessary labor, material or transportation; or changes requested by the Customer), the delivery date will be extended to compensate for the delay as determined by Haworth.

6. Delivery Shortages and Damage

Product shortages and damage must be noted on delivery receipts at the time of delivery and reported to the carrier for correction.

Claims against Haworth for shortages, errors, or damage must be made within ten (10) days of the date of delivery or the Customer waives the right to make such a claim. Signed Bill of Ladings or Delivery Receipt must be sent in with claims. See the Haworth/Haworth Dealers Roles and Responsibilities document for further details.

7. Storage

Haworth may transfer product to storage at the Customer's risk and expense if the Customer is unable or unwilling to take delivery of product as originally scheduled. Upon such transfer to storage, the Customer assumes risk of loss. Haworth will invoice the Customer for storage fees and the Customer will make payments in accordance with Haworth's standard payment terms.

North American Terms of Sale

D. General Terms

1. Governing Law

For products purchased for delivery in the U.S. pursuant hereto, this Agreement shall be governed by and construed according to the laws of the State of Michigan. Where Products are purchased for delivery in Canada pursuant hereto, this Agreement shall be governed by and construed according to the laws of the Province of Alberta. In either case, the parties attorn to the exclusive jurisdiction of the courts of Michigan and Alberta, respectively for the purpose of hearing any disputes arising under this Agreement or with respect to any Products sold pursuant hereto, and agree that the provisions of the United Nations Convention on Contracts for the International Sale of Goods and any other provision or law which would have the effect of applying the laws of any jurisdiction other than Michigan or Alberta, as the case may be, shall be excluded.

2. Force Majeure

In the event that the performance of Customer or Haworth or its participating dealer assignee(s) would be prevented, restricted, interfered with or rendered commercially impracticable by reason of Force Majeure, then upon the giving of notice to the other parties, the party affected by the Force Majeure shall be excused from performing hereunder until the Force Majeure no longer prevents, restricts, interferes with, or renders such performance commercially impracticable.

"Force Majeure" shall mean: fire, explosion, breakdown of plant, epidemic, hailstorm, snow/ice storms en route, hurricane, tornado, cyclone, flood or power failure; war, revolution, civil or military disturbances, acts of public enemies, acts of terrorism, blockade or embargo; any law, order, proclamation, regulation, ordinance, demand or requirement of any applicable governmental authority or any subdivision, authority, or representative of any such government; labor difficulties, including without limitation, strikes, slowdowns, picketing or boycotts; or difficulties beyond Haworth's reasonable control in obtaining necessary raw materials, labor, fuels and electric power, components or facilities, and any other circumstances beyond the control of the party affected.

3. Delays by Customer

Where Haworth has not received adequate site dimensions, Product specifications, shipping information, installation particulars or other information required by Haworth to permit the efficient manufacture of any Products, or where site conditions are not in accordance with the Installation Requirements set forth, or are not otherwise suitable to permit effective and efficient installation, the manufacture and/or delivery of Products may be delayed, and such event shall constitute a delay by the Customer. When manufacture, delivery or installation is delayed by the Customer or at the Customer's request: (i) Haworth may, at its option, present the invoice for the full price of the Products to the Customer as then due and payable; (ii) the Customer shall pay to

Haworth all reasonable storage, handling and other reasonable incidental expenses incurred by Haworth in connection with such delay; and (iii) the Customer shall bear all risk of loss or damage to the Products being held by Haworth for the Customer.

4. Use and Installation of Products

Haworth recommends that its products be installed by certified, qualified and approved installers according to Haworth's written installation procedures. The Customer agrees to use Haworth products properly; not to remove or alter safety devices, warnings, or operation instructions placed on products by Haworth, and to instruct employees as to the proper care and use of the products according to printed instructions.

5. Warranty

Haworth's standard North American Warranty will apply as appropriate. All product line warranty specifics are available in each catalog or upon request.

E. Services

Service requests for design, installation, relocation, storage, etc. are handled by the local Haworth dealer on a separately negotiated basis. Contact the local Haworth dealer, affiliate or area sales office for more details.

Scope of Work - Design

Customer acknowledges that the Products to be manufactured or procured by Haworth in connection with the order are or may be custom manufactured for the Customer and that Haworth may be required to perform extensive work in relation to the design and specification of such Products. Where Customer requests that Haworth create as-built drawings or make more than two material revisions to any particular Product design or specification, Customer agrees that Haworth shall be entitled to invoice Customer with respect to such additional work on the basis of Haworth's then prevailing rates for related design and specification services.

Installation Requirements

Where installation services are to be provided by Haworth, its authorized dealer or subcontractor, a document will be provided setting forth the scope of installation work to be performed (the "Scope of Work") and the price to be charged therefore. Unless otherwise specified in the scope of work, Haworth's installation services are limited to products sold by Haworth with the exception of lighting, under floor electrical and data.

General Conditions

(a) Sufficient time shall be allocated by the Customer following delivery of Products and prior to Customer's occupation of the premises to allow the installation of all Products during conventional working hours, Monday through Friday, 7:30 a.m. to 4:30 p.m. Where sufficient time is not allocated and Haworth is required or requested to perform installation work outside of such times, overtime charges shall be charged at Haworth's then prevailing rates. (b) Haworth shall be given free and exclusive access to; (i) a loading dock within 150' of the freight elevator or hoist, which loading dock shall be of sufficient size to enable full-size tractor-trailer deliveries to the premises (where required by Haworth); (ii) a freight elevator or hoist of sufficient size and capacity to allow the efficient movement of the Products; (iii) an unobstructed and safe pathway to the area where Products are to be stored or staged; (iv) a secure storage / staging area; (v) convenient trash facilities; (vi) adequate lighting; (vii) a work site that complies with applicable health and safety legislation. Where such areas and facilities are not available, Haworth shall be entitled to bill Customer for all amounts incurred by Haworth for double-handling, product movement, lifting, hoisting, trash removal and any other resulting charges. (c) The installation site shall be free and clear of existing furniture, debris, or other obstructions (including construction in progress) and shall otherwise be in the reasonable opinion of Haworth ready for installation of the Products. Any building where Products are to be installed shall be fully closed in, dry and protected from the natural elements, with temperatures between 40°F and 90°F (4°C and 32°C) and relative humidity not to exceed 70% at all times including receipt of products, during and after installation and shall be adequately heated and/or air-conditioned. Where unusual site conditions exist which impede or prevent the normal installation of any Products, applicable extra charges shall apply at prevailing rates. (d) Haworth's installation pricing is based upon the installation occurring as one continuous delivery and installation project. Phased installation pricing shall be provided by Haworth on a case by case basis. (e) Electrical hardwiring, plumbing and mechanical work is not included and shall be the responsibility of the Customer. (f) Except as may be otherwise specifically indicated, installation pricing does not apply to projects where union labor is required. Where Haworth has provided installation pricing on the basis that non-union labor be utilized, and where Haworth is required to use union labor or it otherwise becomes impractical to use non-union labor, or where Haworth is required by law to use prevailing wages, Haworth shall be entitled to charge the Customer for any cost differential between the anticipated cost of non-union labor and the actual cost of utilizing union or prevailing wage labor. (g) Haworth shall not be responsible for obtaining permits.

North American Terms of Sale

Project / Site Conditions

Lateral load bracing is not included in the scope of Haworth's work and shall not be performed by Haworth. In areas where flooring Products are to be installed by Haworth overhead construction must be completed prior to the commencement of such work to avoid damage to the panels and finishes. The existing subfloor must be smooth, mopped clean, free of moisture, dust, dirt and debris. Once installed, the access floor must be maintained in the same manner. The subfloor must have a maximum vertical elevation deviation of 0.375" (10mm) over a horizontal span of 10'-0" (3m), and without discontinuities in floor slope. For greater certainty, the scope of Haworth's installation work in such areas shall not be deemed to include any work required to level such subfloor, remove protrusions, remove pre-existing floor coverings or adhesives, or any other work which is required to remedy any conditions which may impede the efficient installation of flooring. Except as may be otherwise specifically indicated in the order, installation pricing for flooring Products and the Scope of Work in relation thereto shall not include any work required to remove and replace floor panels following their initial installation to provide tradespersons or others with access to the underpanel cable management cavity. In areas where movable walls are to be installed, all flooring (including carpeting) and ceiling components (including dropped ceiling grid components) shall be fully complete and ready for the installation of the movable wall products. Further, the existing floor (or other surface on which the movable wall panels are to be installed) shall have a maximum vertical deviation of 1.25" (30mm) and the dropped ceiling grid shall have a maximum vertical deviation of 0.375" (10mm) from the specifications to which such movable wall panels were designed and manufactured (collectively the "Permitted Tolerances"), and shall otherwise comply with any site condition assumptions made known to Haworth prior to the manufacture of such Products (the "Site Assumptions"). Where the Permitted Tolerances or Site Assumptions are not strictly adhered to or met, additional charges may be incurred in connection with site remediation and/or the modification or remanufacture of affected movable wall products, together with all resulting shipping and labor charges at Haworth's then prevailing rates for such Products and services.

Installation Change Orders

Where Customer requests work to be performed or materials to be provided which are not contemplated in the Scope of Work, or Customer otherwise requests Products or services not contemplated in the order (collectively "Extras"), prior to providing such Extras Haworth reserves the right to require the Customer to provide and sign a written Purchase Order or Change Order acceptable to Haworth describing the Extras and the amounts to be charged therefore, and the Customer agrees to pay such charges.

Entire Agreement

The order and this Agreement (including applicable Schedules) constitute the sole agreement between the parties and supercede any prior understanding or written or oral agreements between the parties (excluding National Sales Agreements). No waiver of any of the provisions of these Standard Terms and Conditions shall be binding on Haworth unless expressly agreed in writing.

Revision Date: June 1, 2015

Index

Products are listed alphabetically in this index by alpha-numeric prefix/suffix codes.

Product Code	Product Description	Page
2670	Accessories – Counterweight	.75
9060-8803	Accessories – Top Filler Track	.71
EQAD-0000-GD	Beside Electrical – Patch Cord Data Holder Bracket — Beside Storage Only	.83
EQAG-0000-PT	Electrical Components – Top Feed Grommet — Beside Storage Only	.79
EQAG-0000-PT	Electrical Components – Top Feed Grommet — Beside Storage Only	.82
EQEP-0000-C	Electrical Components – Hardwire Kit — Beside Storage Only	.82
EQET-C000-2	Electrical Components – Top Feed — Beside Storage Only	.79
EQET-C000-3	Electrical Components – Top Feed — Beside Storage Only	.79
EQET-C000-4	Electrical Components – Top Feed — Beside Storage Only	.79
EQET-C000-C	Electrical Components – Top Feed — Hardwire Beside Storage Only	.82
EUDZ-0000-QD	Beside Electrical – Modular Furniture Telecommunication Opening — Beside Storage Only	.83
EUDZ-0000-WDD	Beside Electrical – Modular Furniture Telecommunication Opening — Beside Storage Only	.83
EUEB-0000-2HY	Electrical Components – Base Feed Module — Architectural Concealed — Hardwire Connection	.78
EUEB-0000-3HY	Electrical Components – Base Feed Module — Architectural Concealed — Hardwire Connection	.78
EUEB-0000-4HY	Electrical Components – Base Feed Module — Architectural Concealed — Hardwire Connection	.78
EUEH-0087-2	Electrical Components – Infeed Harness	.76
EUEH-0087-3	Electrical Components – Infeed Harness	.76
EUEH-0087-4	Electrical Components – Infeed Harness	.76
EUEJ-0018-2	Belong Electrical Components – Jumpers	.152
EUEJ-0018-2	Electrical Components – Jumpers	.81
EUEJ-0018-3	Electrical Components – Jumpers	.81
EUEJ-0018-4	Electrical Components – Jumpers	.81
EUEJ-0064-2WF	Electrical Components – Internal Power Base™ AI Base Feed	.77
EUEJ-0064-3WF	Electrical Components – Internal Power Base™ AI Base Feed	.77
EUEJ-0064-4WF	Electrical Components – Internal Power Base™ AI Base Feed	.77
EUEP-0030-2Q	Electrical Components – Power Distribution Assembly — Beside Storage Only	.80
EUEP-0030-3Q	Electrical Components – Power Distribution Assembly — Beside Storage Only	.80
EUEP-0030-4Q	Electrical Components – Power Distribution Assembly — Beside Storage Only	.80
EURT-0072-1010	Electrical Components – Bezel Utility Model	.151
KUAG	Belong Electrical Components – Grommet	.152
LUTS-16UEP	Task Lighting – Adaptable Electronic Ballast Task Light	.130
QAFF	Accessories – Filler Panel	.71
QAGB	Accessories – Ganging Bracket Kit	.74
QAGC	Accessories – Saddle	.148
QALA	Accessories – Upper Slat Rail	.148
QALB	Accessories – Lower Slat Rail	.148
QALD	Accessories – Personal Drawer	.147
QALF	Storage Pantry Finished Back	.146
QALH	Accessories – Hanging File Drawer	.147
QALS	Accessories – Adjustable Shelf	.147
QASD	Accessories — Base Unit Accessory Shelf – Double Units — Open/Functional	.68
QASD	Accessories — Base Unit Accessory Shelf – Double Units — Open/Open	.68
QASD	Accessories — Base Unit Accessory Shelf – Single Sliding Door	.69
QASR	Accessories — Base Unit Accessory Shelf – Double Sliding Door	.69
QASS	Accessories — Base Unit Accessory Shelf – Single Units — Open and Functional	.68
QAST	Accessories — Base Unit Accessory Shelf – Triple Unit	.70
QBBK	Finished Back – Finished Back	.67
QBDF	Base Unit — Hinged Door and Drawer Combination – Hinged Door — Drawer Combination	.51
QBDF-PNN	Base Unit — Double Sliding Door – Double Sliding Door	.63
QBDF-QNN	Base Unit — Double Sliding Door – Double Sliding Door	.63
QBDF-SZN	Base Unit — Single Sliding Door – Single Sliding Door	.59
QBDF-AZN	Base Unit — Drawer Combinations — Double – Drawer Combinations — Double	.30
QBDF-BZN	Base Unit — Drawer Combinations — Double – Drawer Combinations — Double	.30

Product Code	Product Description	Page
QBDF-CZLN	Base Unit — Open Storage with a Drawer — Double	.18
QBDF-CZLN	Base Unit — Open Storage with a Drawer — Double	.18
QBDF-DZLN	Base Unit — Open Storage with a Drawer — Double	.18
QBDF-DZLN	Base Unit — Open Storage with a Drawer — Double	.18
QBDF-EZLN	Base Unit — Drawer Combinations — Double – Drawer Combinations — Double	.30
QBDF-FZLN	Base Unit — Open Storage with a Drawer — Double	.18
QBDF-HZLN	Base Unit — Hinged Door – Hinged Door	.38
QBDF-KZLN	Base Unit — Hinged Door and Open Storage Unit – Hinged Door — Open Storage Unit	.45
QBDF-LZLN	Base Unit — Hinged Door and Open Storage Unit – Hinged Door — Open Storage Unit	.45
QBDF-ZTLN	Base Unit — Single Sliding Door – Single Sliding Door	.59
QBDO	Base Unit — Open Storage – Open	.10
QBFC_F	Accessories – Cushion	.75
QBRA	Storage Top – Rectangular	.66
QBSF	Base Unit — Hinged Door and Drawer Combination – Hinged Door — Drawer Combination	.51
QBSF-2330	Base Unit — Open Storage with a Drawer — Single – Open Storage with a Drawer — Single	.12
QBSF-2930	Base Unit — Open Storage with a Drawer — Single – Open Storage with a Drawer — Single	.12
QBSF-ANN	Base Unit — Drawer Combinations — Single – Drawer Combinations — Single	.26
QBSF-BNN	Base Unit — Drawer Combinations — Single – Drawer Combinations — Single	.26
QBSF-ENN	Base Unit — Drawer Combinations — Single – Drawer Combinations — Single	.26
QBSF-GNN	Base Unit — Hinged Door – Hinged Door	.38
QBSF-KNN	Base Unit — Hinged Door and Open Storage Unit – Hinged Door — Open Storage Unit	.45
QBSO	Base Unit — Open Storage – Open	.10
QBTF	Base Unit — Hinged Door and Drawer Combination – Hinged Door — Drawer Combination	.51
QBTF-HZH	Base Unit — Hinged Door – Hinged Door	.38
QBTF-ZAZ	Base Unit — Drawer Combinations — Triple – Drawer Combinations — Triple	.35
QBTF-ZBZ	Base Unit — Drawer Combinations — Triple – Drawer Combinations — Triple	.35
QBTF-ZRZ	Base Unit — Double Sliding Door – Double Sliding Door	.63
QEBT-PP	Overhead Storage Unit Accessories – Top Mount Bracket	.128
QLG1-LLF	Storage Pantry — Laminate Case and Front	.138
QLG1-LWF	Storage Pantry — Laminate Case with Wood Front	.140
QLG1-WLF	Storage Pantry — Wood Case with Laminate Front	.142
QLG1-WWL	Storage Pantry — Wood Case with Wood Front	.144
QLG1-ZLLF	Storage Pantry — 28" High	.136
QNGB-PM	Overhead Storage Unit Accessories – Top Mount Bracket	.128
QNGB-PZ	Overhead Storage Unit Accessories – Top Mount Bracket	.128
QUHT	Accessories – Hutch Shelf	.104
QULS	Task Lighting – Adaptable Light Skirt	.130
QUS1-AXXNX	Overhead Storage Unit — Hinged Doors — Laminate Case – Single Sided	.107
QUS1-AXXNX	Overhead Storage Unit — Hinged Doors — Wood Case	.111
QUS1-CXXNX	Overhead Storage Unit — Hinged Doors — Laminate Case – Single Sided	.107
QUS1-CXXNX	Overhead Storage Unit — Hinged Doors — Laminate Case – Single Sided	.107
QUS1-CXXNX	Overhead Storage Unit — Hinged Doors — Wood Case	.111
QUS1-CXXNX	Overhead Storage Unit — Hinged Doors — Wood Case	.111
QUS1-EXXVX	Overhead Storage Unit — Sliding Doors — Laminate Case	.115
QUS1-EXXVX	Overhead Storage Unit — Sliding Doors — Wood Case	.119
QUS1-GXXVX	Overhead Storage Unit — Sliding Doors — Laminate Case	.115
QUS1-GXXVX	Overhead Storage Unit — Sliding Doors — Laminate Case	.115
QUS1-GXXVX	Overhead Storage Unit — Sliding Doors — Wood Case	.119
QUS1-GXXVX	Overhead Storage Unit — Sliding Doors — Wood Case	.119
QUS1-HXNNN	Overhead Storage Unit — Open – Single Sided Open	.105
QUS2-DXXVX	Overhead Storage Unit — Sliding Doors — Laminate Case – Dual Sided	.124
QUS2-DXXVX	Overhead Storage Unit — Sliding Doors — Wood Case – Dual Sided	.126
QUS2-JXNNN	Overhead Storage Unit — Open – Dual Sided	.122
QUSS	Stanchion Kit — G – Stanchion Kit — G	.84
QUSS	Stanchion Kit — H – Stanchion Kit — H	.85

Index

Product Code	Product Description	Page
QUSS	Stanchion Kit — M – Stanchion Kit — M	.87
QUSS	Stanchion Kit — N – Stanchion Kit — N	.91
QUSS	Stanchion Kit — P – Stanchion Kit — P	.94
QUSS	Stanchion Kit — Q – Stanchion Kit — Q	.100
QUUG	Overhead Storage Unit Accessories – Ganging Tie Plate Bracket	.129
QZBT-PPA	Overhead Storage Unit Accessories – Top Mount Bracket	.128
QZBT-PPH	Overhead Storage Unit Accessories – Top Mount Bracket	.128
SFCK	Accessories – Front-to-Back Hanging Bars	.74
SUFB	Belong Screens – Screen — Back	.132
SUPC	Belong Screens – Screen — Center	.134
UZCC	Overhead Storage Unit Accessories – Off Modular Top Trim Mounting 18”-120” for Compose	.128
ZBBG-PN	Attachment Brackets	.149
Z()BQ-LA	Accessories – Storage to Panel Bracket	.72
Z()BQ-RE	Accessories – Storage to Panel Bracket	.72
ZKBG-PN	Attachment Brackets	.149
ZTBG-PN	Attachment Brackets	.149
ZUBF-PN	Accessories – Flush Mount Plate	.73
ZUBG-PNFC	Accessories – Desk-to-Storage Bracket	.73
ZUBG-PNHC	Accessories – Desk-to-Storage Bracket	.73
ZUBG-PNNN	Accessories – Storage Attachment Bracket	.73
ZUBT-0307-PN	Attachment Brackets	.149
ZUBW-PN	Attachment Brackets	.149
ZZBC	Accessories – Adaptable Anti-Dislodgement Clip Kit	.72
ZZBF-1800-PNW	Attachment Brackets – Compose Panel to Pantry Bracket	.150

Great Expectations

You have them as a Haworth customer and so do we. And because **we value our customers**, we cover our products with the Haworth North America Product Compatibility and Limited Warranty Policy.

Product Compatibility And Limited Warranty Policy

OUR COMMITMENT TO PRODUCT COMPATIBILITY – INTEGRATED PRODUCT PLATFORMS

As a market leader in the design and manufacture of workspaces that adapt to change, we strive to maintain product compatibility within our various generations of integrated product platforms. This benefits the customer who desires to update or modify their work environment. It also benefits the customer needing to replace a product due to damage or other reasons but which is no longer manufactured or is otherwise unavailable, such as a fabric or finish that is discontinued because of changing market preferences. In both circumstances, we often can provide products with comparable function and performance.

OUR COMMITMENT TO PRODUCT QUALITY – THE HAWORTH NORTH AMERICA LIMITED WARRANTY

To ensure customer satisfaction and peace of mind, we stand behind our products with the Haworth North America Limited Warranty. To review the current version of the limited warranty including its terms and conditions, please go to: www.haworth.com/resources/product-info/warranties or contact Haworth's First Call Center at **800.426.8562**.

WARRANTY REQUESTS OR QUESTIONS

For questions or service requests pertaining to the Haworth Limited Warranty, please contact your Haworth dealer. If you are unsure who your dealer is, please call Haworth's First Call Center at **800.426.8562**.

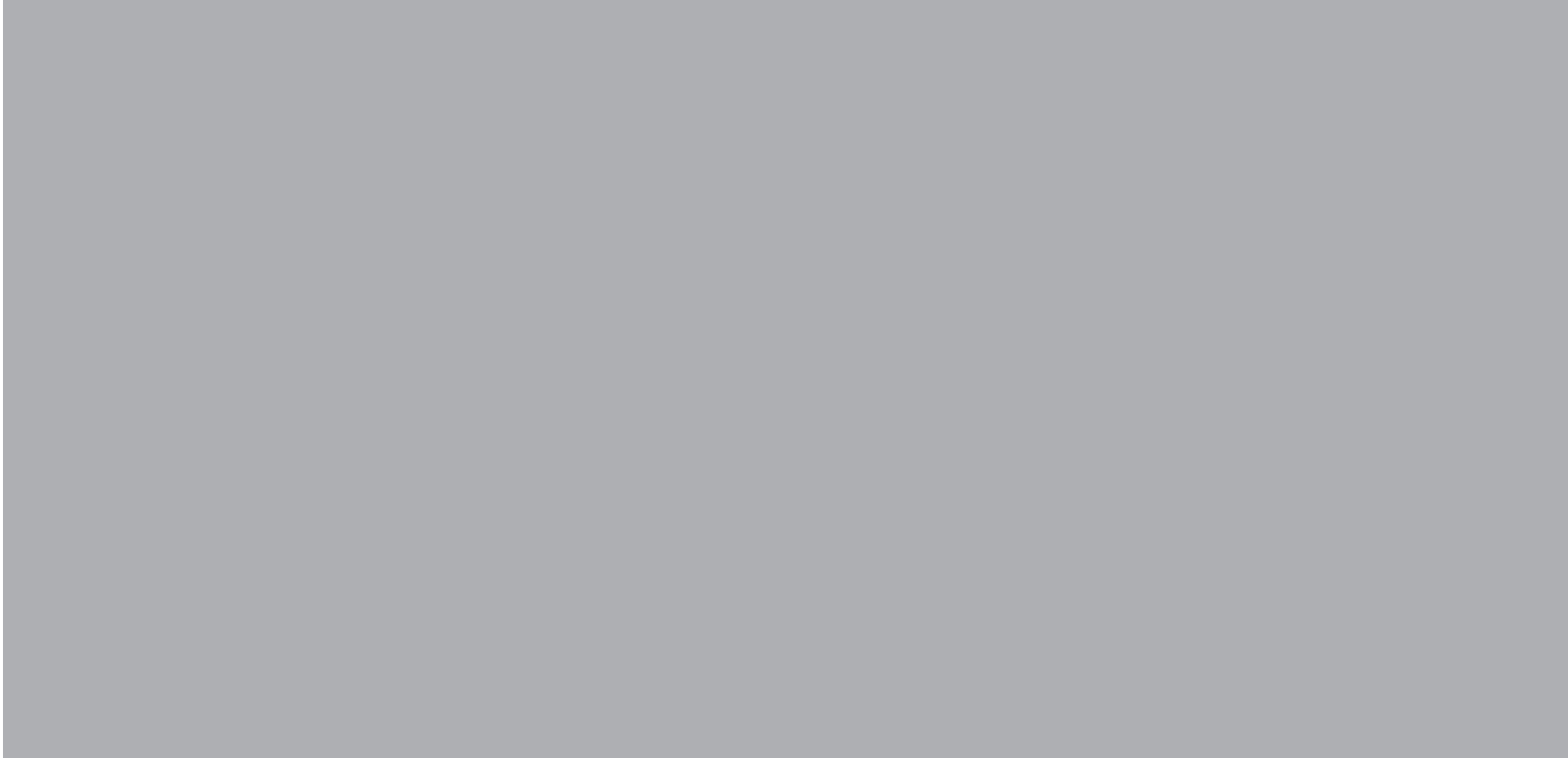

HAWORTH®

For more information call 800.344.2600 or 616.393.3000.

Haworth is a registered trademark of Haworth, Inc.

©Haworth, Inc. 2018 4.18 Item #0010

haworth.com | haworth-europe.com | haworth-asia.com



Haworth's Integrated Palette includes
Compose®, Enclose®, Patterns™, Planes®,
Reside®, Beside® and Belong™.