

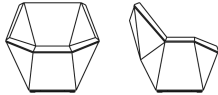























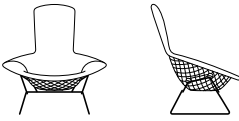

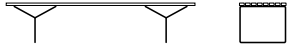

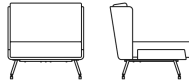
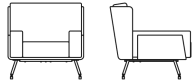
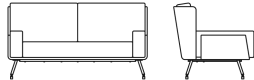
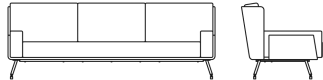
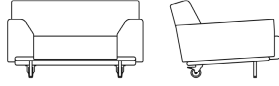
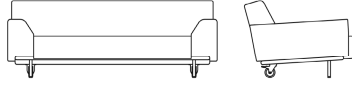

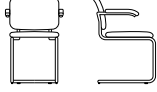
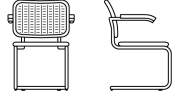
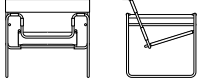

Introduction	Designer Index	3
	Visual Index	5
	Using the KnollStudio Price List	16
	Spinneybeck Leather Grades	17
	Upholstery Notes	18
	🔥 California Technical Bulletin 133	19
	Knoll and Sustainable Design	22
	GREENGUARD™ Certified KnollStudio Products	23
	KnollStudio Finish Code Chart: Compatibility with Knoll Office Systems	25
	Materials and Finishes	26
	Product Maintenance	28
	📅 KnollStudio 20-Day Program	30
	📅 KnollStudio 20-Day Program Upholstery Scope	30
	📅 Items Available on KnollStudio 20-Day Program	31
	Placing Your KnollStudio Order	33
	Side Chairs and Lounge Seating	David Adjaye : The Washington Collection for Knoll™
Edward Barber & Jay Osgerby : Sofa Collection		38
Edward Barber & Jay Osgerby : Pilot by Knoll® Lounge Collection		46
Edward Barber & Jay Osgerby : Piton™ Stools		50
Harry Bertoia : Side Chair		52
Harry Bertoia : Two-Tone Side Chair		54
Harry Bertoia : Barstools		56
Harry Bertoia : Bertoia Molded Shell Side Chair and Barstool		60
Harry Bertoia : Diamond Lounge Seating		62
Harry Bertoia : Two-Tone Diamond Chair		64
Harry Bertoia : Bird Lounge Chair and Ottoman		66
Harry Bertoia : Asymmetric Chaise		68
Harry Bertoia : Bench		70
Pierre Beucler and Jean-Christophe Poggioli: Contract Lounge Seating		72
Pierre Beucler and Jean-Christophe Poggioli: Residential Lounge Seating		78
Cini Boeri : Lounge Collection		90
Marcel Breuer : Cesca Chair		94
Marcel Breuer : Wassily Chair		98
Don Chadwick : Spark® Series		100
Jonathan Crinion : Crinion Chair		104
Joseph Paul D'Urso : Contract Lounge Seating		106
Joseph Paul D'Urso : Residential Lounge Seating		110
Joseph Paul D'Urso : Swivel Lounge Seating		114
Raul de Armas : de Armas Chair		116
Raul de Armas : Vertical de Armas Chair		122
Frank Gehry : Side and Dining Chairs		126
Frank Gehry : Lounge Seating		128
Markus Jehs and Jürgen Laub : Jehs+Laub Lounge Collection, pedestal base		130
Markus Jehs and Jürgen Laub : Jehs+Laub Lounge Collection, wire base		132
Florence Knoll : Lounge Seating		134
Florence Knoll : Relaxed Lounge Seating		136
KnollStudio : Throw Pillows		138
Antti Kotilainen : CHIP Chair and Barstool		140
Marc Krusin : Guest Seating Collection		142
Maya Lin : Stones	152	
Piero Lissoni : Divina® Lounge Seating	156	
Ross Lovegrove : Sprite Armless Chair	162	
Ross Lovegrove : Sprite Arm Chair	164	
Vico Magistretti : Cirene Stacking Chair	166	
Marco Maran : Gigi® Arm Chair	168	
Marco Maran : Gigi® Armless Chair	172	
Marco Maran : Gigi® Armless Chair with Sled Base	176	

Side Chairs and Lounge Seating (cont'd.)	Marco Maran : Gigi® Barstool and Swivel Chair	180	
	Ludwig Mies van der Rohe : Tubular Brno Chair	182	
	Ludwig Mies van der Rohe : Flat Bar Brno Chair	184	
	Ludwig Mies van der Rohe : Four Seasons Stool	186	
	Ludwig Mies van der Rohe : MR Lounge Seating	188	
	Ludwig Mies van der Rohe : MR Chair	190	
	Ludwig Mies van der Rohe : Barcelona® Lounge Seating	192	
	Ludwig Mies van der Rohe : Krefeld™ Collection	194	
	George Nakashima : Straight Chair	200	
	Jonathan Olivares : Aluminum Stacking Chair	202	
	Jorge Pensi : Toledo Stacking Chair	204	
	Charles Pfister : Petite Lounge Seating	206	
	Charles Pfister : Lounge Seating	210	
	Charles Pfister : Sofa System	212	
	Warren Platner : Seating Collection	214	
	Warren Platner : Easy Chair and Ottoman	216	
	Charles Pollock : Executive Conference Arm and Armless Chairs	218	
	Charles Pollock : Arm Chair	220	
	Carlos Riart : Riart Rocker	222	
	Joe Ricchio : Joe™ Chair	224	
	Joe and Linda Ricchio : JR® and Ricchio Chair with Upholstered Seat	226	
	Joe and Linda Ricchio : Fully Upholstered Ricchio and JR® Chairs	230	
	Jens Risom : Seating	234	
	Jens Risom : Outdoor Seating	240	
	Eero Saarinen : Tulip Chairs	242	
	Eero Saarinen : Executive Arm Chairs	244	
	Eero Saarinen : Executive Armless Chairs	248	
	Eero Saarinen : Womb Chair, Ottoman and Settee	252	
	Richard Schultz : 1966 Collection® Dining Chairs	260	
	Richard Schultz : 1966 Collection® Barstools	262	
	Richard Schultz : 1966 Collection® Lounge Seating	264	
	Richard Schultz : 1966 Collection® Chaise Lounge Chairs	266	
	Richard Schultz : Swell® Seating Collection	268	
	Richard Schultz : Topiary® Seating Collection	270	
	Shelton Mindel : Shelton Mindel Side Chair	272	
	Shelton Mindel : SM1 Lounge Collection	274	
	Shelton Mindel : SM2 Lounge Collection	276	
	Kazuhide Takahama : Suzanne Lounge Seating	280	
	Ufficio Tecnico : Spoleto Chair	282	
	Vignelli Associates : Handkerchief Armless Chair	284	
	Vignelli Associates : Handkerchief Arm Chair	286	
	Tables/Executive Office	David Adjaye : The Washington Collection for Knoll™	288
		Franco Albini : Albini Desk	292
Edward Barber & Jay Osgerby : Piton™ Side Table		294	
Marcel Breuer : Laccio Tables		296	
Joseph Paul D'Urso : Square Work and Low Tables		298	
Joseph Paul D'Urso : Round Work and Low Tables		300	
Joseph Paul D'Urso : Racetrack Work Tables		304	
Frank Gehry : Face Off Cafe Table		306	
Alexander Girard : Coffee Table		308	
Florence Knoll : Oval Table Desks		310	
Florence Knoll : Round Table Desk		312	
Florence Knoll : Dining Tables and Mini Desk		314	
Florence Knoll : Executive Desk		318	
Florence Knoll : Credenzas		320	
Florence Knoll : Coffee Tables		324	
Florence Knoll : End Tables		326	
Florence Knoll : Hairpin™ Stacking Table		328	
Rem Koolhaas : 04 Counter		330	
Marc Krusin : Occasional Tables		332	
Lucia Mercer : Mercer Table		334	

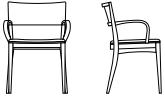
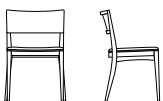
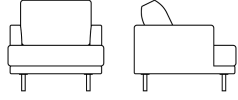
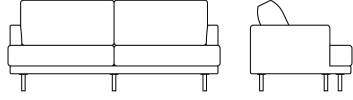
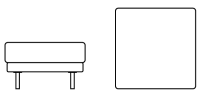
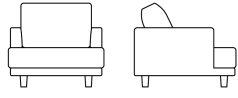
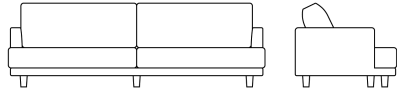
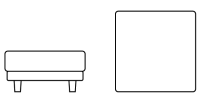
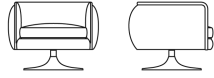
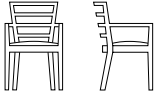
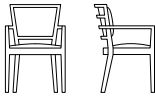
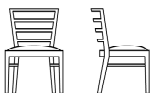
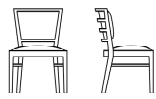
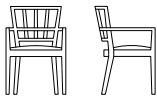
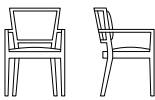
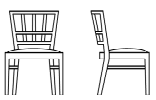

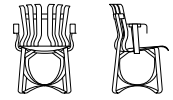
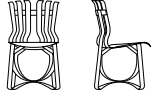
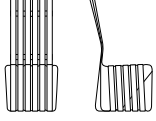
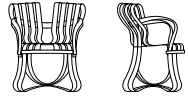
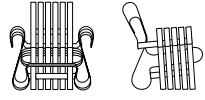
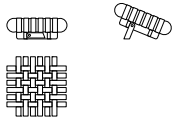
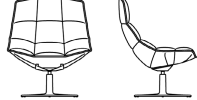
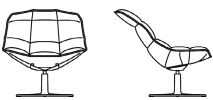

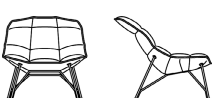









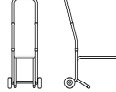



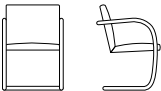

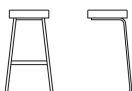
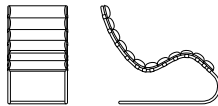
Tables/Executive Office (cont'd.)	Ludwig Mies van der Rohe : Barcelona® Table, MR Table	336
	Ludwig Mies van der Rohe : Krefeld™ Side and Coffee Table	338
	Pascal Mourgue : Square and Rectangular Conference Tables	340
	Pascal Mourgue : Round and Racetrack Conference Tables	342
	Pascal Mourgue : Bullet Conference Tables	344
	George Nakashima : Splay-Leg Table and Tray	346
	Isamu Noguchi : Cyclone™ Dining and Side Tables	348
	Jorge Pensi : Pensi Tables	350
	Piironen : Arena Cafe Tables	354
	Warren Platner : Dining and Side Tables	356
	Warren Platner : Coffee Tables	358
	Jens Risom : Dining and Side Tables	360
	Jens Risom : Child's Amoeba Table	362
	Jens Risom : Outdoor Tables	364
	Eero Saarinen : Round Dining Tables	366
	Eero Saarinen : Oval Dining Tables	372
	Eero Saarinen : Round End and Coffee Tables	374
	Eero Saarinen : Oval End and Coffee Tables	378
	Eero Saarinen : Outdoor Tables	380
	Richard Schultz : Petal® Table Collection	382
	Richard Schultz : 1966 Collection® Dining Tables	384
	Richard Schultz : 1966 Collection® Counter Height Tables	386
	Richard Schultz : 1966 Collection® Bar Height Tables	388
	Richard Schultz : 1966 Collection® End and Coffee Tables	390
	Richard Schultz : 1966 Collection® Serving Cart	394
	Richard Schultz : Topiary® Dining Tables	396
	Shelton Mindel : SM Tables	398
	Daniel Stromborg : Round Tables	400
	Daniel Stromborg : Square Tables	402
	Daniel Stromborg : Rectangular Tables	404
	Vignelli Associates : PaperClip™ Cafe Tables	406
Alpha-Numeric Index		407
Selling Policy		412
General Ordering Information		414

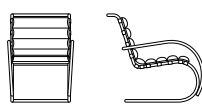
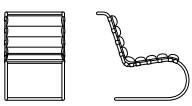
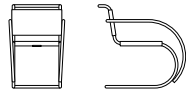
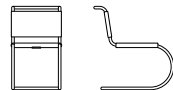





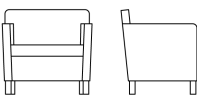
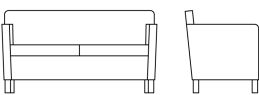
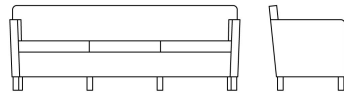





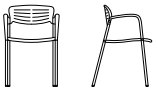

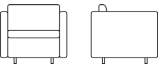
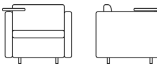
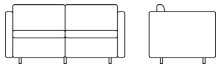
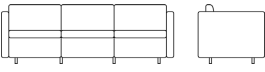
David Adjaye	34-37, 288-291
Franco Albini	292-293
Edward Barber & Jay Osgerby	38-45
Edward Barber & Jay Osgerby	46-51, 294-295
Harry Bertola	52-71
Pierre Beucler & Jean-Christophe Poggioli	72-89
Cini Boeri	90-93
Marcel Breuer	94-99, 296-297
Don Chadwick	100-103
Jonathan Crinion	104-105
Raul de Armas	116-125
Joseph Paul D’Urso	106-115, 298-305
Frank Gehry	126-129, 306-307
Alexander Girard	308-309
Markus Jehs and Jürgen Laub	130-133
Florence Knoll	134-137, 310-329
Rem Koolhaas	330-331
Antti Kotilainen	140-141
Marc Krusin	142-151, 332-333
Maya Lin	152-155
Piero Lissoni	156-161
Ross Lovegrove	162-165
Vico Magistretti	166-167
Marco Maran	168-181
Lucia Mercer	334-335
Ludwig Mies van der Rohe	182-199, 336-339
Pascal Mourgue	340-345
George Nakashima	200-201, 346-347
Isamu Noguchi	348-349
Jonathan Olivares	202-203
Jorge Pensi	204-205, 350-353
Charles Pfister	206-213
Piiroinen	354-355
Warren Platner	214-217, 356-359
Charles Pollock	218-221
Carlos Riart	222-223
Joseph Ricchio	224-233
Linda Ricchio	226-233
Jens Risom	234-241, 360-365
Eero Saarinen	242-259, 366-381
Richard Schultz	260-271, 382-397
Peter Shelton & Lee Mindel	272-279, 398-399
Daniel Stromborg	400-405
Kazuhide Takahama	280-281
Ufficio Tecnico	282-283
Vignelli Associates	284
Vignelli Associates: David Law, Lella Vignelli & Massimo Vignelli	406-407

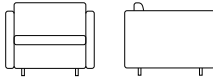
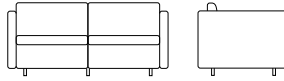
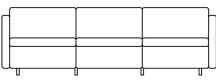

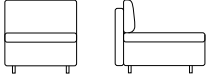

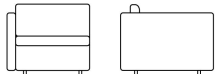
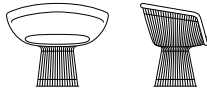

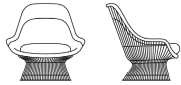
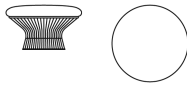

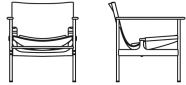
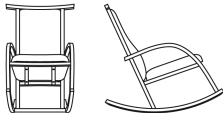

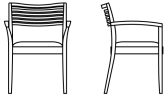
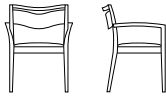
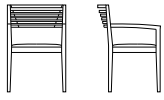
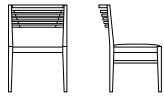
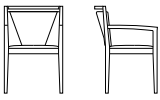
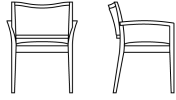

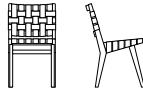
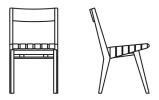





Page	SIDE CHAIRS AND LOUNGE SEATING				
34	ADJAYE	Prism™ Lounge chair 	Prism™ Ottoman 	Washington Skin™ 	Washington Skeleton™ 
38	BARBER & OSGERBY	Sofa 	Ottoman 	Arm chair 	Pillow 
		Piton™ stools 	Pilot High back 	Pilot Low back 	
52	BERTOIA	Side chair 	Barstools 	Diamond chair 	Child's Diamond chair 
		Large Diamond chair 	Bird high back chair 	Ottoman 	Bench 
		Asymmetric Lounge 			
72	BEUCLER & POGGIOLI	Small lounge chair 	Lounge chair 	Settee 	Sofa 
90	BOERI	Lounge chair 		Sofa 	
		Ottoman 	Large pillow 	Small pillow 	
94	BREUER	Cesca chair 	Cesca chair, cane 	Wassily chair 	
		Spark side chair 	Spark lounge chair 		



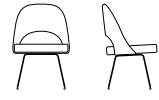

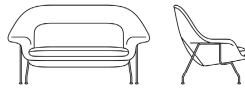





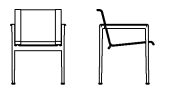

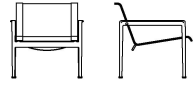
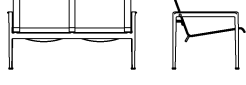
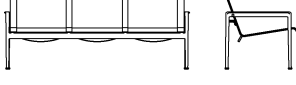

Page		SIDE CHAIR AND LOUNGE SEATING, continued			
104 105	CRINION	Crinion arm chair 	Crinion armless chair 		
106 115	D'URSO	Contract Lounge chair 	Small Sofa 	Ottoman 	
		Residential Lounge chair 	Sofa 	Ottoman 	
		Swivel Lounge chair 			
116 123	DE ARMAS	de Armas arm chairs 		de Armas armless chairs 	
		Vertical de Armas arm chairs 		Vertical de Armas armless chairs 	
126 129	GEHRY	Hat Trick arm chair 	Hat Trick armless chair 	High Sticking chair 	Cross Check chair 
		Power Play chair 	Offside ottoman 		
130 133	JEHS+LAUB	Lounge chair, pedestal base 		Ottoman, pedestal base 	
		Lounge chair, wire base 		Ottoman, wire base 	

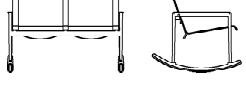
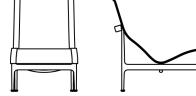
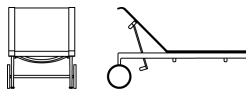
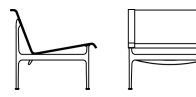

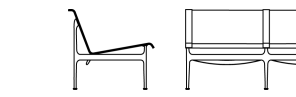

Page		SIDE CHAIR AND LOUNGE SEATING, continued			
134	KNOLL	Lounge chair	Settee	Sofa	
		Two seater bench	Three seater bench		
		Relaxed Lounge Chair	Relaxed Settee	Relaxed Sofa	
138	KNOLLSTUDIO	Lumbar pillow	Throw pillow	Large throw pillow	
140	KOTILAINEN	CHIP armless chair	CHIP arm chair	CHIP barstools	Dolly
		Ganging mechanism			
142	KRUSIN	Arm chair	Arm chair with inset	Armless chair	Armless chair with inset
		Arm lounge	Armless lounge		
152	LIN	Adult stones	Child stones	Stones Coffee table	
156	LISSONI	Divina Lounge chair	Petite Lounge chair	Settee	Sofa
		Ottoman			





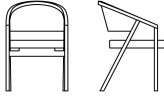
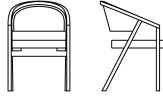
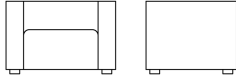
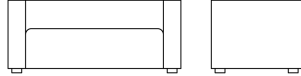
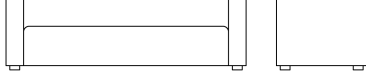
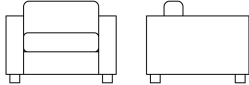
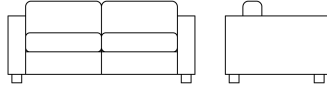
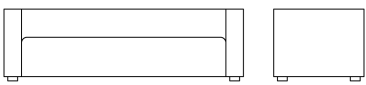
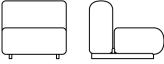

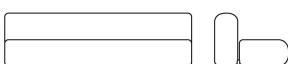
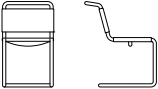







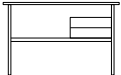





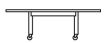

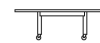

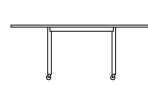



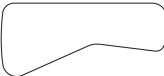
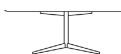

Page		SIDE CHAIR AND LOUNGE SEATING, continued			
162	LOVEGROVE	Sprite armless chair 	Sprite arm chair 	Sprite Dolly 	
166	MAGISTRETTI	Cirene arm stacking chair 	Cirene armless stacking chair 	Cirene Dolly 	
168	MARAN	Gigi arm chair 	Gigi armless chair 	Gigi Barstools 	Gigi Swivel chair 
182	MIES VAN DER ROHE	Tubular Brno chair 	Flat Bar Brno chair 	Four Seasons stool 	
		MR Chaise lounge 	MR adjustable chaise lounge 	MR arm lounge chair 	MR armless lounge chair 
		MR arm chair 	MR armless chair 		
192	MIES VAN DER ROHE	Barcelona chair 	Child's Barcelona chair 	Barcelona stool 	Child's Barcelona stool 
		Barcelona stool with cowhide sling 	Barcelona couch 		
		Krefeld Lounge chair 	Krefeld Settee 	Krefeld Sofa 	
		Krefeld medium and large benches 	Ottoman 		

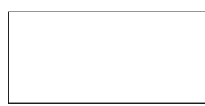
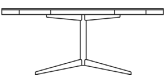

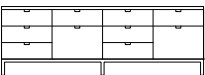







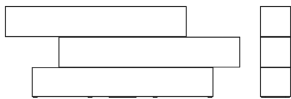

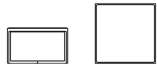

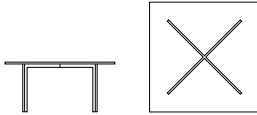
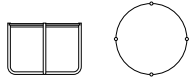
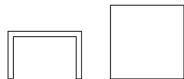
Page	SIDE CHAIRS AND LOUNGE SEATING, continued					
200	NAKASHIMA	Straight chair				
						
202	OLIVARES	Olivares chair				
						
204	PENSI	Toledo chair	Toledo chair seat cushion			
						
206	PFISTER	Petite Lounge chair	Petite Lounge chair with tablet arm	Petite Settee	Petite Sofa	
						
		Petite Ottoman	Lounge chair	Settee	Sofa	
						
		Ottoman	Modular Sofa System Center module	End modules	Corner module	
						
214	PLATNER	Lounge chair	Arm chair	Stool	Easy chair	Ottoman
						
218	POLLOCK	Executive Conference arm chair	Executive Conference armless chair		Arm chair	
						
222	RIART	Riart Rocker				
						

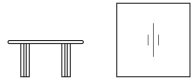
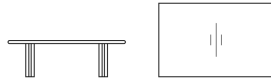

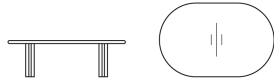

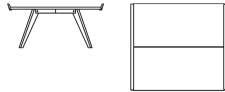



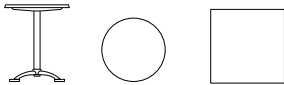
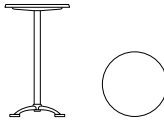
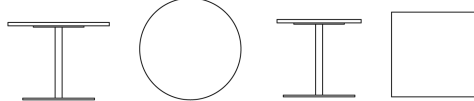
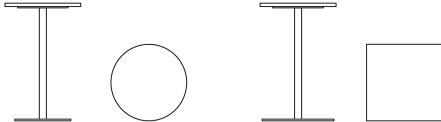

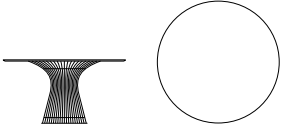

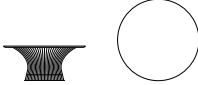
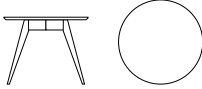

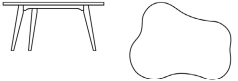
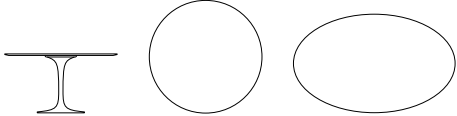
Page		SIDE CHAIRS AND LOUNGE SEATING, continued			
224	RICCHIO	Joe arm chair	JR chair	Ricchio arm chair	Ricchio armless chair
					
		Ricchio Fully upholstered chair JR Fully upholstered chair			
					
234	RISOM	Lounge chairs		Side chairs	
					
		Sitting stool	Child's Side chairs		Child's Sitting stool
					
242	SAARINEN	Tulip arm chair	Tulip armless chair	Stool	
					
244	SAARINEN	Executive arm chair	Executive armless chair	Arm chair	Armless chair
					
252	SAARINEN	Womb chair	Ottoman	Womb Settee	Medium Womb chair
					
		Medium Ottoman	Child's Womb chair		
					

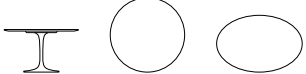
Page	SCHULTZ	SIDE CHAIRS AND LOUNGE SEATING, continued			
260		Dining chair with arm	Dining chair, armless	Counter height armless barstool	Bar height armless barstool
					
		Lounge chair with arms	Two seat lounge chair with arms	Three seat lounge chair with arms	
					
		Single rocker	Double rocker		
					
		Contour chaise lounge	Adjustable chaise lounge		
					
		Single seat club chair	Two seat sofa	Three seat sofa	
					
		Topiary dining chair	Topiary lounge chair	Topiary bench	Topiary small ottoman/end table
					
		Topiary stacking chair			
					

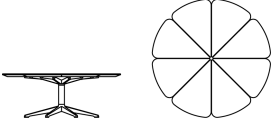
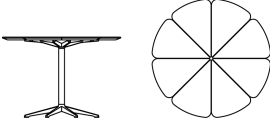
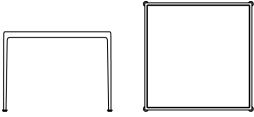
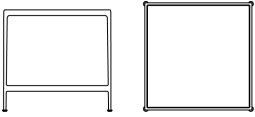
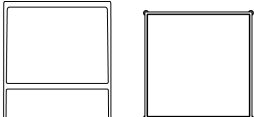
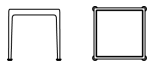
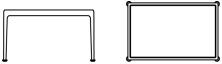
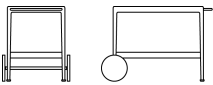
Page		SIDE CHAIRS AND LOUNGE SEATING, continued			
272	SHELTON & MINDEL	SM side chair	SM side chair, fully upholstered		
					
		SM1 Lounge chair	SM1 Settee	SM1 Sofa	
					
		SM2 Lounge chair	SM2 Settee	SM2 Sofa	
					
280	TAKAHAMA	Suzanne lounge chair	Double lounge chair	Settee	Sofa
					
282	TECHNICO	Spoleto chair			
					
284	VIGNELLI ASSOCIATES	Handkerchief arm chair	Handkerchief armless chair		
					

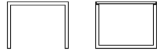
Page	TABLES / EXECUTIVE OFFICE			
288	ADJAYE	Washington Corana™	Prism™ side tables	
				 
292	ALBINI	Pedestal desk		
				
294	BARBER & OSGERBY	PITON™ side tables		
				
296	BREUER	Laccio tables		
				
298	D'URSO	Work and low tables - Square	Work and low tables - Round	Work tables - Racetrack
		 	 	 
306	GEHRY	Face Off café tables		
				
308	GIRARD	Coffee table		
				
310	KNOLL	Oval and Round table desks	Dining Table and Mini Desk	Executive desk
		  	 	 
		Two Position Credenza	Four Position Credenza	Coffee and end tables
				   
		Hairpin stacking table		
				

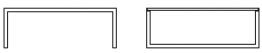
Page	TABLES / EXECUTIVE OFFICE				
330	KOOLHAAS	Counter			
					
332	KRUSIN	Square side tables	Square end tables	Square coffee tables	Square coffee tables
					
336	MIES VAN DER ROHE	Barcelona table	MR table	Krefeld side table	Krefeld coffee table
					
340	MOURGUE	Pascal square table	Pascal rectangular table	Pascal round table	Pascal racetrack table
					
		Pascal bullet table			
					
346	NAKASHIMA	Splay-leg table	Tray		
					
348	NOGUCHI	Cyclone dining table	Cyclone side table		
					
350	PENSI	Pensi tables	Pensi high table		
					
354	PIIROINEN	Arena tables	Arena high tables		
					

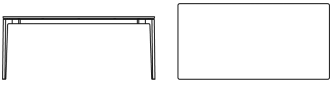
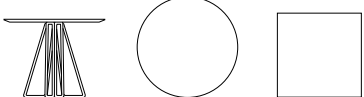
Page	TABLES / EXECUTIVE OFFICE, continued				
356	PLATNER	Dining table	Side table	Coffee tables	
					
360	RISOM	Dining table	Side tables	Amoeba coffee table	Child's Amoeba coffee table
					
366	SAARINEN	Dining tables		Side tables	Coffee tables
					
		Outdoor tables			
					
382	SCHULTZ	Petal end table	Petal coffee table	Petal dining table	
					
		1966 Dining table	1966 Counter Height table	1966 Bar Height table	1966 End table
					
		1966 Coffee table	1966 Serving Cart	Topiary® Dining table	
					
398	SHELTON & MINDEL	SM side table	SM small coffee table	SM large coffee table	SM square coffee table
					
400	STROMBORG	Round table	Square table	Rectangular table	
					
406	VIGNELLI ASSOCIATES	PaperClip tables			
					

A Price List Overview

Where do I send my order? How should I maintain my marble table? From textile options to wood polishes, the KnollStudio price list is designed to provide you with everything you need to know in order to understand, specify, and care for furniture in the KnollStudio Collection.

This book is divided into three easy-to-use sections.

- Side Chairs and Lounge Seating
- Tables and Executive Office
- Propeller Table Series

For a quick overview of the collection's scope, review the Visual Index on pages 5-15. If you're looking for pieces by a specific designer, try the Designer Index on page 4.

Need furniture in a hurry? KnollStudio 20-day on pages 30-31 highlights KnollStudio pieces available in only twenty days.

Leathers, Textiles, and Finishes

If you're confused about which leather to select, pages 17-18 explains the broad selection of Spinneybeck leathers available for KnollStudio furniture.

Additional upholstery notes and Customer's Own Material (COM) information are available on page 18.

For detailed explanations of the many materials used in constructing KnollStudio furniture, consult page 27. A cross-reference of KnollStudio veneer or lumber finishes with standard Knoll Office veneers is provided on page 25. Easy-care maintenance information is also provided on pages 28-29.

Placing Your KnollStudio Order

For information about where to send your order and key terms and conditions, see page 33. The complete Knoll Selling Policy is available on pages 412-413.

General Ordering Information and Knoll's Sustainability Statement is available on page 414

Product Information On Each Page

On each page, the following features will assist you:

Description provides both the pattern number and a basic description of the product.

Dimensions provide the overall space the product will require. Statistics are based on the maximum width, depth, and height of the product.

Weight is based on the product itself. It does not include packaging. Weights are rounded to the nearest pound.

Weights of upholstered items do not include weight of textile/leather. To calculate total weight, multiply covering requirements by textile/leather weight, and add to product weight.

Pattern Number provides both the product identification number and all additional selections required for ordering. Finish options are enclosed in parentheses. Finish suffix descriptions are found under Finishes on the bottom portion of the page.

Order Code/Ordering Information outlines exactly how to specify KnollStudio product and the full scope of finishes and other options. The Order Code provides an example of how one pattern number on the page is specified.

20-Day pieces available in 20 days ex-factory are noted with helicopters  next to the items. Additional information is provided under Ordering Information and in the 20-Day section of this book.

Construction provides specific materials and finishes employed, as well as specific construction details.

Textiles and Leather Grades list by price group all KnollTextiles and Spinneybeck Leathers approved for each seating piece. This list is derived through careful examination of the textile or leather's distinctive upholstery characteristics and the form and structure of each piece of furniture. KnollTextiles or

Spinneybeck leathers that are not listed have been rejected because Knoll cannot ensure their performance on that product. To view the full range of colorways available for each fabric or leather, consult any Knoll or Spinneybeck representative.

Cal 133 Technical Bulletin

Many KnollStudio products meet California Technical Bulletin 133. Information for specifying these items is on page 19. Items available are indicated with a flame . Applicable upcharge will be listed on the respective price list page.

Greenguard

Many KnollStudio products meet Greenguard environmental standards. Please see page 24 for a complete listing of products.

CPSIA Testing

Many knoll kids products meet the consumer Product Safety Improvement Act of 2008 for Children's Products, 16 C.F.R. 1303 CPSIA Title 1 Section 101 for Total Lead in Substrates and Surface Coatings. For a complete listing of approved products, please refer to individual price list pages.

Note to Knoll Dealer Sellers:

The products contained in this price list are also available through the Knoll Essentials program, with limited exceptions. For additional information, please contact your customer service representative or visit Knoll Exchange.

For More Information

For more information, contact your KnollStudio representative, a Knoll Space reailer or e-tailer, or telephone Customer Services at 800 343-KNOLL. To find the retailer or showroom nearest you, visit www.knoll.com.

For the ultimate in comfort, durability, and prestige, many KnollStudio products can be upholstered in Spinneybeck leathers.

Spinneybeck leathers are made from the top 2% of the world's finest hides, inspected numerous times during production to ensure evenness of grain, surface, color and the absence of scars.

After tanning, all Spinneybeck leathers are drum-dyed, a time-consuming procedure which ensures color penetration throughout the hide. Each hide is then finished in the manner which will best bring out its individual character.

Spinneybeck leathers are all full-grain aniline drum-dyed products imported from Italy.

The following Spinneybeck leathers are approved for application on KnollStudio products. Leathers are grouped into five price categories referred to as "grades." The selection of approved leathers varies by product. Please refer to the pricing page of each product line for more information.

Square footage requirements for Customer's Own Leather (COL) are listed on the left side of the pricing page. Please refer to Upholstery Notes on page 18 and The Knoll Selling Policy on pages 412-413 for further information regarding COL.

For further information call Spinneybeck at 1-800-482-7777.

Grades

U

Vicenza
Volo

Characteristics

Heavily finished cowhide, corrected grain, slightly raised grain texture
Heavily finished cowhide, corrected grain, slightly raised grain texture

V

Acqua
Andes
Embossed
Tipped
España
Hand Tipped
Maremma
Velluto Pelle

Heavy water-repellent finished kip, corrected grain, slightly raised grain texture
Slightly pronounced grain cowhide with a medium finish, and enhanced grain
Lightly finished cowhide, full grain, embossed pronounced pebble grain
Smooth, tight grain cowhide; breathable, protective medium finish, enhanced grain
Two-toned leather, lightly finished cowhide, pronounced pebble grain texture
Full grain textured suede with impregnated soil-resistant treatment
Slightly pronounced grain cowhide with a medium finish, enhanced grain

W

Alaska
Amazon
Antique
Derby
Forte
Lucente
Sabrina

Pearlized-iridescent protective finish cowhide, full grain with smooth texture
Mid-weight, full grain cowhide; colors of the Amazonian jungle, raised grain texture
Smooth tight grain cowhide, lightly antiqued to produce an elegant patina, enhanced grain
Combination-tanned cowhide; full grain, medium finish and raised grain texture
High performance, full grain leather with slightly pronounced grain texture
Smooth, very tight grain cowhide; subtle sheen; light casein finish
Smooth, tight and full grain kip with a breathable protective finish

X

Ducale
Ducale
Velour

Embossed shrunken grain cowhide, medium protective finish, full grain
Full grain-sueded cowhide, embossed shrunken grain, scotch-guarded

Y

Capri
Cervo
Copenhagen
Distressed
Lucca
Marissa
Portofino
Riva
Saddle
Torello

Chrome-free, light protective finish, full grain cowhide
Full aniline, pronounced grain texture, soft luxurious hand
Full aniline, 100% vegetable tanned leather, full grain
Aniline-dyed, paraffin wax final ironing process with a smooth finish, and full grain
Aniline-dyed, pebble grain sueded leather
Grain-sueded cowhide, scotch-guarded smooth suede grain
Full grain, lightly finished cowhide, with a pronounced raised texture
Slightly pronounced grain texture, water-repellent, full grain
Full aniline, smooth very tight grain surface takes on a rich patina over time
Full grain, aniline dyed, natural shrunken bovine leather; light protective finish

Textile and Leather Notes

All seating in this price list includes the cost of applied fabric or leather. To simplify ordering, the seating is arranged into specific upholstery grades and priced accordingly. Samples and prices of cut textiles are available on request. For a full list of the Spinneybeck leathers available, see page 17.

Leather*The Natural Qualities of Leather*

Natural leather is unique. Because every animal is different, each hide has its own individual color, texture, and life-marks. In fact, our leathers are painstakingly treated to retain their natural appearance and hand. Range marks are not camouflaged. Colors and texture vary, and will do so more with age as the leather mellows and takes on a rich patina.

Spinneybeck Leathers

Spinneybeck offers full-grain Italian leathers.

Spinneybeck features three different tanning processes which preserve the leather. The first is mineral tannage, in which chromium salts are used; the second is vegetable tannage, in which bark tanning is used; and the third is a combination of the first two processes. Each leather is tanned in the manner which will best accentuate its unique characteristics.

Spinneybeck leathers are drum-dyed which tumbles the leather over and over for smooth, even coloring absorbed directly into the leather. This aniline-dyeing process enhances the natural qualities of leather grain. Many competitors use vat-dyeing. This does not dye the leather in an even manner.

If you have further questions on Spinneybeck leathers, contact your Knoll representative or telephone Spinneybeck Customer Service at 1-800 482-7777.

Below are additional details on the three major types of Spinneybeck leathers.

Naked Leather (Capri, Copenhagen, Distressed, Maremma, Saddle) Naked leather contains no foreign substances which would affect the superbly soft, mellow hand of this most luxurious of upholstery leathers. Natural markings are

accentuated. Since there are no barriers against spillage or staining, naked leathers should be carefully specified. However, scratches and marks will dissipate in time as the leather develops a beautiful patina.

Leathers with Protective Finishes:

(Acqua, Alaska, Amazon, Andes, Antique, Derby, Ducale, España, Forte, Hand Tipped, Lucente, Montalcino, Portofino, Riva, Sabrina, Velluto Pelle, Volo)

For high traffic areas, protective finishes allow leather to be not only practical, but easy to maintain.

Grain Sueded Leathers (Ducale Velour, Marissa)

Full grain leathers that have been lightly buffed to raise the nap of the surface are referred to as "grain sueded" leathers. This produces the soft hand of sueded leathers. For maximum soil resistance and durability, these leathers have received an impregnated soil resistance treatment during the drum-dye process which permeates the leather, making it repellent to liquid and dirt.

Textile*Classic Boucle*

Classic Boucle is with spun Boucle yarn that is a blend of wool and nylon that is piece dyed. Color can vary from lot-to-lot and it is important to use the same lot for multiple piece orders. Please notate sales order when items must match. Classic Boucle, Pearl contains natural, un-dyed wool and will have darker hairs woven within the textile.

Knoll Upholstery Restrictions

Every Knoll leather and fabric is exhaustively tested on each Knoll upholstered item. This is done in addition to the most extensive program of independent fabric testing in the industry. On furniture, testing ensures precise fit and appearance, without stretch, puddling, telegraphing or other common problems frequently experienced when careful factory pre-qualification is eliminated.

When Knoll suggests that a particular leather or fabric not be used on an object, this does not mean the material is defective in any way; it only implies less than perfect performance with the form and structure of a specific item on furniture.

Instructions for Ordering Nano-Tex

The minimum for Nano-Tex on KnollStudio orders is 1-lot of \$206 net for up to 65 yards. Nano-Tex orders of 65 yards or more is \$3.00 net/yard.

Dealer instructions for ordering Nano-Tex:

- 1) Visit knolltextiles.com/technical documents and open the Nano-Tex specifications to see if the fabric is approved with the finish.
- 2) If approved, check the seating matrix at knolltextiles.com to see if the fabric alone is approved on the chair. (If yes, proceed to #3).
- 3) Contact your account manager with the fabric name, treatment required, and name and pattern number of desired chair. They will see if Knoll has tested this fabric with finish/treatment on said chair. In most cases, application testing has not been done and they will contact the appropriate parties to initiate approval and determine leadtime for testing.
- 4) If approved, book order with a suffix of N (for Nano-Tex) after the fabric pattern number.
- 5) The fabric grade will remain the same. Add line item for finish/treatment required and multiply the finish cost by the number of yards required.

Customer's Own Material (COM)**Customer's Own Leather (COL)**

While Knoll is pleased to cooperate with COM/COL selections, an extra charge is required to help offset receiving and handling costs. Such charges are included under the COM/COL title of the price columns in this price list. Prior to order placement, a sample cutting of actual COM/COL must be submitted to Knoll in East Greenville or through your regional Knoll office for preliminary approval of intended item (8' x 8" minimum memo sample if solid; if COM has a repeat, the sample must be large enough to show the repeat).

Even after such preliminary approval, Knoll reserves the right to reject COM/COL, including, if necessary, the item intended for use with COM/COL, if Knoll considers the customer-supplied material inadequate for any reason. When COM/COL is accepted, KnollStudio assumes no responsibility for its appearance, durability, color fastness or any other quality after upholstered on a Knoll product.

Published yardage requirements are based upon Knoll 52" width material unless specified otherwise. Leather requirements are based on whole hides with a minimum of 50 square feet per hide. However, in some cases, the nature or pattern of COM/COL will require additional yardage/square feet and/or additional labor charges. When this is necessary, the customer will be notified at the same time that the preliminary sample is approved.

If your COM/COL is approved, you may send the required amount for the product to:

Knoll, Inc.
1235 Water St
East Greenville, PA 18041
Attn: Customer Resources

COM/COL must be marked with designated approval number and customer's name.

For additional information, see Customer's Own Material (COM) under Selling Policy on pages 412-413.

Test Objective

California Technical Bulletin 133 (Cal 133) is a full-scale seating test, not a component test. Testing must be performed on the designated seating unit and textile together. Component data alone cannot be used to certify compliance with the regulation. Under Cal 133 you cannot assume that seating or textiles that have passed individually will pass together.

Test Procedure

The seating unit is exposed to a square open flame gas burner for 80 seconds, positioned at the center of the seating unit, two inches from the back and one inch from the seat.

Scope

Cal 133 only applies to seating units. The bulletin is designed for high risk public areas:

- Nursing homes
- Health care facilities
- Public auditoriums
- Hotels (more than 10 seating units in one room)
- Motels (more than 10 seating units in one room)
- Jails and prisons

Tables and desks are not covered by the bulletin. Variations may occur in individual states with regards to specific application. In California only, compliance is at the discretion of the fire marshal in any building which is fully sprinklered.

KnollStudio Approvals

Tested seating units have been tested in a worst case scenario thus covering other fabrics of lighter weight and same construction. When specifying Cal 133, the seating unit may be constructed with a fire resistant foam and a fire blocker will be laminated to the textile.

How To Specify

It is easy to specify Cal 133 on KnollStudio seating. Simply add the suffix “C” to the end of the pattern number prior to the textile selection. Approved textile selections must have the suffix 133 added to the end of the pattern number.

Example: Bertoia side chair, chrome, seat pad in Common Ground/Basalt 420C-C-K-C-K448/12-133

Testing Additional Product

If you would like to test a specific product:

Specify chair and textile desired - adding appropriate C and 133 codes as explained.

Testing lead time will be the standard lead time of the chair plus 4 - 6 weeks for testing procedure.

Test cost will be the regular price of the chair plus \$500 for the testing procedures.

Cal 133 tested and approved fabrics and seating units are indicated with a flame . All prices below are list.

KnollStudio CAL 133 Approved Products					
Designer	Product	Pattern #	Unupholstered, no upcharge	Knoll Textiles, upcharge	Spinneybeck leather, upcharge
Bertoia	Side Chair, seat cushion	420K	approved	approved, no upcharge	approved, no upcharge
Bertoia	Barstools, Bar Height, seat cushion	427K	approved	approved, no upcharge	approved, no upcharge
Bertoia	Barstools, Counter Height, seat cushion	428K	approved	approved, no upcharge	approved, no upcharge
Bertoia	Diamond Lounge Chair	421K	approved	approved, no upcharge	approved, no upcharge
Bertoia	Diamond Lounge Chair	421F	approved	approved, no upcharge	approved, no upcharge
Bertoia	Child’s Diamond Lounge Chair	421LS-K		approved, no upcharge	approved, no upcharge
Bertoia	Child’s Diamond Lounge Chair	421LS-U		approved, no upcharge	
Bertoia	Large Diamond Chair	422F		approved, no upcharge	
Bertoia	Bird Lounge Chair and Ottoman	423LU, 424YU		approved, no upcharge	
Bertoia	Asymmetric Chaise	429LU, 429F		approved, no upcharge	
Boeri	Lounge Chair	CB1		\$674.00	\$893.00
Boeri	Sofa	CB2		\$921.00	\$1,272.00
Boeri	Ottoman	CB3		\$393.00	\$714.00
Breuer	Cesca Chair	50A, 50C		\$101.00	
Breuer	Wassily Chair	50L	approved		approved
Chadwick	Spark Series	4-C-SD-S, 4-C-LG-S		\$64.00	
Crinion	Crinion Chair	58A, 58C		\$64.00	
D’Urso	Lounge Chair	2160, 2160R		\$645.00	\$754.00
D’Urso	Lounge Chair, split upholstery	2160S, 2160RS		\$981.00	\$980.00
D’Urso	Swivel Lounge Chair	2165		\$583.00	
D’Urso	Small Sofa	2161		\$1,151.00	\$1,260.00
D’Urso	Small Sofa, split upholstery	2161S		\$1,513.00	\$1,513.00
D’Urso	Residential Sofa	2162R		\$1,406.00	\$1,513.00
D’Urso	Residential Sofa, split upholstery	2162RS		\$1,766.00	\$1,766.00
D’Urso	Ottoman	2163, 2163R		\$347.00	\$462.00
D’Urso	Ottoman, split upholstery	2163S, 2163RS		\$589.00	\$589.00
de Armas	de Armas Chair Collection	38A, 38AW, 38C, 28CW, 41A, 41AW, 41C, 41CW		\$64.00	\$64.00
de Armas	de Armas Chair Collection	38AW-U, 38CW-U, 41AW-U, 41CW-U		\$113.00	\$113.00

KnollStudio CAL 133 Approved Products (continued)					
Designer	Product	Pattern #	Unupholstered, no upcharge	Knoll Textiles, upcharge	Spinneybeck leather, upcharge
Jehs+Laub	Lounge Chair	JL1-P, JL1-PLt, JL2-P, JL2-PLT, JL1-W, JL1-WLT, JL2-W, JL2-WLT		\$266.00	\$361.00
Jehs+Laub	Ottoman Chair	JL3-P, JL3-PLT, JL3-W, JL3-WLT		\$102.00	\$179.00
Knoll	Lounge Chair	1205S1		\$620.00	\$730.00
Knoll	Settee	1205S2		\$1,080.00	\$1,275.00
Knoll	Sofa	1205S3		\$1,445.00	\$1,705.00
Knoll	Small Bench	2530Y2C		\$144.00	\$387.00
Knoll	Large Bench	2530Y3C		\$223.00	\$266.00
Kotilainen	CHIP Chair	23C, 23A	approved		
Lin	Stones, seat pad	83Y-K, 84Y-K		\$64.00	
Lissoni	Divina Petite Lounge Chair	67S		\$418.00	\$785.00
Lissoni	Divina Standard Lounge Chair	67, 67R		\$671.00	\$979.00
Lissoni	Divina Settee	68, 68R		\$1,031.00	\$1,550.00
Lissoni	Divina Optional Side Cushion	68C		\$92.00	
Lissoni	Divina Sofa	69, 69R		\$1,546.00	\$1,996.00
Lissoni	Divina Ottoman	73, 73R		\$368.00	\$671.00
Lovegrove	Sprite Arm and Armless Chair	27C, 27A	approved	\$64.00	\$64.00
Mies van der Rohe	Tubular Brno Chair	245AT, 245AB		\$680.00	\$680.00
Mies van der Rohe	Flat Bar Brno Chair	255AS, 255CS		\$680.00	\$680.00
Mies van der Rohe	Four Seasons Stool	257C			\$178.00
Mies van der Rohe	Barcelona Lounge Chair	250LS, 250LC			\$556.00
Mies van der Rohe	Child's Barcelona Chair	250LC-S			\$489.00
Mies van der Rohe	Barcelona Ottoman	251YS, 251YC			\$281.00
Mies van der Rohe	Child's Barcelona Ottoman	251YC-S			\$242.00
Mies van der Rohe	Krefeld Lounge Chair	751		\$593.00	\$941.00
Mies van der Rohe	Krefeld Settee	752		\$733.00	\$1,309.00
Mies van der Rohe	Krefeld Sofa	753		\$1,008.00	\$1,692.00
Mies van der Rohe	Krefeld Ottoman	754		\$275.00	\$491.00
Mies van der Rohe	Krefeld Medium Bench	755		\$459.00	\$740.00
Mies van der Rohe	Krefeld Large Bench	756		\$503.00	\$999.00
Pensi	Toledo Stacking Chair	29C	approved		
Pfister	Standard Lounge Chair, Petite Lounge Chair	1051C, 1051C-S		\$684.00	\$1,033.00
Pfister	Standard Settee	1052C		\$1,171.00	\$1,788.00
Pfister	Standard Sofa	1053C		\$1,526.00	\$2,532.00
Pfister	Corner Module	1050C-3		\$640.00	\$1,048.00
Pfister	End Module, left panel and right panel	1050C-1, 1050C-2		\$573.00	\$895.00
Pfister	Center Module	1050C		\$469.00	\$739.00
Pfister	Standard Ottoman	1059C		\$360.00	\$495.00
Pollock	Executive/Conference Arm and Armless Chairs	12A, 12C		\$118.00	\$118.00
Ricchio	Joe Chair	48A		\$64.00	\$64.00
Ricchio	Ricchio Chair	37A, 37C		\$64.00	\$64.00
Ricchio	JR Chair	44A		\$64.00	\$64.00
Ricchio	Fully Upholstered Ricchio Chair	37A-U, 37C-U, 44A-U		\$180.00	\$180.00
Ricchio	Ricchio Barstool	37CH, 37CM		\$64.00	\$64.00
Risom	Risom Stool, Side and Lounge Chair	666C, 667Y, 666CS, 667YS, 654LA, 654LC		approved, no upcharge	approved, no upcharge
Saarinen	Executive Arm Chairs	71A		\$286.00	\$414.00
Saarinen	Executive Armless Chairs	72C		\$197.00	\$414.00
Saarinen	Womb Settee	73L		\$870.00	\$1,618.00
Saarinen	Womb Chair	70L		\$695.00	\$1,283.00
Saarinen	Medium Womb Chair	70LM		\$483.00	\$1,171.00
Saarinen	Womb Ottoman	74Y		\$210.00	\$383.00
Saarinen	Medium Womb Ottoman	74YM		\$163.00	\$335.00
Shelton Mindel	Side Chair	SM8A		\$64.00	\$64.00
Shelton Mindel	Side Chair Fully Upholstered	SM8A-U		\$180.00	\$178.00
Shelton Mindel	SM1 Lounge Chair	SM1-1		\$592.00	\$743.00

KnollStudio CAL 133 Approved Products (continued)					
Designer	Product	Pattern #	Unupholstered, no upcharge	Knoll Textiles, upcharge	Spinneybeck leather, upcharge
Shelton Mindel	SM1 Settee	SM1-2		\$824.00	\$1,060.00
Shelton Mindel	SM1 Sofa	SM1-3		\$1,033.00	\$1,405.00
Shelton Mindel	SM2 Lounge Chair	SM2-1		\$758.00	\$824.00
Shelton Mindel	SM2 Lounge Chair- combination	SM2S-1		\$1,335.00	\$1,335.00
Shelton Mindel	SM2 Settee	SM2-2		\$1,213.00	\$1,285.00
Shelton Mindel	SM2 Settee- combination	SM2S-2		\$1,979.00	\$1,979.00
Shelton Mindel	SM2 Sofa	SM2-3		\$1,782.00	\$1,940.00
Shelton Mindel	SM2 Sofa- combination	SM2S-3		\$2,809.00	\$2,809.00
Vignelli Associates	Handkerchief Arm and Armless Chair	4901K, 4902K	approved	\$64.00	

Each year Knoll sets key initiatives in our journey to sustainability. We are members of a global consortium on energy, have adopted a scientific, metrics-based approach to sustainable product design, and maintain a leadership position in establishing universal, verifiable, sustainability standards for our industry.

Knoll promotes independent third-party certification because it provides the most impartial and trustworthy foundation for industry-wide environmental compliance. Certification by established and respected third parties ensures that all manufacturers are held to the same high standards and that customers can trust a company's declaration about the environmental benefits of its products. Knoll third-party partners include: the International Standards Organization (ISO); Forest Stewardship Council (FSC®); Rainforest Alliance; GREENGUARD® Environmental Institute; and The Business and Institutional Furniture Manufacturer's Association (BIFMA) level® certification from Scientific Certification Systems (SCS).

In addition, Knoll is aligned with the U.S. Green Building Council and can help companies, healthcare organizations and educational institutions achieve Leadership in Energy and Environmental Design (LEED®) workplace certification.

Global Climate Change

- Knoll is a sponsor of the Clinton Global Initiative, which brings together a community of global leaders to devise and implement solutions to some of the world's most pressing challenges, including environmental change.
- Knoll has a comprehensive Energy Management Program to increase energy efficiency in products and processes.

Life Cycle Assessment (LCA) Tool

- Life Cycle Assessment is a science-based measurement of a product's environmental impacts throughout its life cycle, from raw materials sourcing through manufacture, shipping, use and re-use or end-of-life. LCA enables cradle-to-cradle implementation of sustainable practices.

Setting Industry Standards

- Knoll partners with MTS (The Institute for Market Transformation to Sustainability) to develop the SMaRT® Consensus Sustainable Products Standards, a set of consensus-based sustainable product standards based on the LEED® model, for all building products, fabric, apparel, flooring and carpet. MTS, the developer of SMaRT®, is an accredited American National Standards Institute (ANSI) standard developer.
- Knoll also partners with BIFMA (Business and Institutional Furniture Manufacturers Association) to promote level® sustainability standards for the contract furniture industry.
- Knoll has established FSC® (Forest Stewardship Council) certified wood as the standard for general office open plan office systems, casegoods and tables.
- Knoll has launched Full Circle, a resource recovery program developed with ANEW, to help customers extend the life cycle of surplus furniture, fixtures and equipment (FF&E) in an economically, socially and environmentally responsible manner.
- Our goal is to encourage all manufacturers in the contract furniture industry and related industries to adopt standards that will lead to sustainable products and practices.

For more information about Knoll and sustainable design, visit knoll.com/environment.

GREENGUARD™

- The most respected independent testing program for low-emitting products.
- GREENGUARD™ – certified products help reduce indoor air pollution and create healthier interior environments.
- Knoll GREENGUARD™ – certified products help achieve points for the U.S. Green Building Council’s LEED – CI (Commercial Interiors) Program.
- GREENGUARD™ – tested and certified office furniture is required for Credit 4.5 in the LEED – CI Indoor Environmental Quality section.

GREENGUARD™ provides the only guide to certified low-emitting interior products and building materials. Its goal is to help building owners and managers, architects, interior designers and product specifiers build and furnish healthier offices, hospitals, schools and homes by providing a register of tested and certified low-emitting products and materials. GREENGUARD™ certification is recognized by LEED. Air Quality Science, an Independent indoor air quality laboratory, tests products submitted for GREENGUARD™ certification using stringent environmental chamber testing protocols and current indoor air quality standards. Certification is administered by the GREENGUARD™ Environmental Institute.

Designer	Product
Side Chairs and Lounge Seating	
David Adjaye	Washington Skin and Skeleton Chairs
Paul Aferiat and Peter Stamberg	Salsa Lounge Seating
Edward Barber and Jay Osgerby	Piton Stools
Harry Bertoaia	Side Chair, Barstools, Diamond Chairs, Bird Lounge Chair, Asymmetric Chaise
Cini Boeri	Lounge Collection
Marcel Breuer	Cesca Chair, Wassily Chair
Don Chadwick	Spark Series
Jonathan Crinion	Crinion Side Chair
Raul de Armas	de Armas Chair, Vertical de Armas Chair
Markus Jehs and Jürgen Laub	Jehs+Laub Lounge Collection
Antti Kotilainen	Chip Chair and Barstool
Florence Knoll	Lounge Seating
Knoll Design	k. lounge Collection and k. lounge Throw Pillows
Marc Krusin	Wood Guest Seating Collection
Piero Lissoni	Divina Lounge Collection
Ross Lovegrove	Sprite Chair in Maple, Exotic Alpi and Veneer finishes
Maya Lin	Seats and Coffee Table
Vico Magistretti	Cirene Chair
Marco Maran	Gigi Chair, Gigi Swivel, Gigi Barstool, X3 Chair, X3 Barstool
Ludwig Mies van der Rohe	Brno Chairs, Four Seasons Stool, MR Chair, MR Lounge Chair, Barcelona Lounge Seating, Krefeld Lounge Seating
George Nakashima	Straight Chair
Jonathan Olivares	Aluminum Chair
Jorge Pensi	Toledo Chair
Charles Pfister	Petite Lounge Seating, Lounge Seating, Sofa System
Warren Platner	Lounge Seating
Charles Pollock	Executive/ Conference Arm and Armless Chairs
Carlos Riart	Riart Rocker
Joe Ricchio	Joe Chair
Joe and Linda Ricchio	JR Chair, Ricchio Chair
Jens Risom	Side and Lounge Chairs
Eero Saarinen	Tulip Chairs, Executive Arm and Armless Chairs, Womb Chair and Ottoman
Richard Schultz	1966 Collection, Topiary, Swell and Fresh Air Seating
Peter Shelton and Lee Mindel	Shelton Mindel Wood Side Chair, SM1 Lounge Collection, SM2 Lounge Collection
Kazhide Takahama	Suzanne Lounge Seating
Ufficio Tecnico	Spoletto Chair
Massimo and Lella Vignelli	Handkerchief Arm and Armless Chairs

Designer	Product
Tables	
David Adjaye	Washington Corona Table
Edward Barberand Jay Osgerby	Piton Side Table
Marcel Breuer	Laccio Table
Joseph D'Urso	D'Urso Tables with Laminate Top and PVC Edge; Granite Tops; Veneer Tops
Alexander Girard	Coffee Table
Florence Knoll	Coffee and End Tables
Florence Knoll	Table Desks
Florence Knoll	Credenzas and Executive Desk
Ross Lovegrove	Rectangular, Round and Tri-Oval Tables
Ludwig Mies van der Rohe	Barcelona Table, MR Table
Pascal Mourgue	Tables with laminate Tops and PVC Edge
George Nakashima	Splay-Leg Table
Isamu Noguchi	Cyclone Table
Jorge Pensi	Pensi Tables
Piironen	Arena Café Tables
Warren Platner	Platner Tables with Glass, Natural Marble and Veneer Tops
Jens Risom	Dining Table, Side Tables, Amoeba Coffee Table
Eero Saarinen	Saarinen Tables with Laminate, Natural Marble, Veneer or Granite Tops
Richard Schultz	1966 Collection, Petal and Topiary Tables
Peter Shelton and Lee Mindel	Shelton Mindel Side and Coffee Tables
Massimo and Lella Vignelli	PaperClip Café Tables

KnollStudio Finish Code Chart

Compatibility with Knoll Office Systems

Wood Compatibility Matrix

To match KnollStudio wood side chairs with Knoll Office or KnollStudio veneer finishes, please specify the appropriate Special code. Finishes are matched on either maple or beech basewood depending on depth of color.

Please note: this match is complimentary in color only. Perception can be affected by the variation in the grain of the basewood.

Example: **37A-BQV436-K784/74**

37A, Ricchio Side Chair

BQV436, V2 Natural Veneer - Medium Brown Cherry

K784/74, Knoll Velvet/Moss

To match Propeller, Pixel, and LSM with Knoll Office or KnollStudio finishes, please submit a request through CPD. Any of the finishes listed below may be used at no additional upcharge.

KNOLL OFFICE VENEER FINISHES			STUDIO WOOD SIDE CHAIR FINISHES	
	CUT	Standard Finish Code	Special Code - Maple	Special Code - Beech
V1 Engineered Techwoods				
Maple *	FC	Y316	•	•
Cherry *	FC	Y319	•	BQY319
Medium Walnut*	FC	Y323	•	B323
Dark Mahogany*	FC	Y326	•	BQY326
Light Oak*	RC	Y327	QY327	•
Medium Oak*	RC	Y329	•	BQY329
Wenge	QC	Y341	•	BQY341
Medium Teak	QC	Y342	•	BQY342
Dark Grey Oak	RC	Y343	•	BQY343
Espresso	QC	Y344	•	BQY344
Natural**	QC	Y811 (T)	QY811	•
Blond Maple (Maple)**	QC	Y821 (4)	KC	•
Light Cherry (Cherry)**	QC	Y831 (6)	•	BQY831
Medium Brown Mahogany	QC	C6F3 (7)	•	BQE7
Black Oak	RC	Y851	•	BQY851
Medium Red Mahogany	QC	C6F4 (8)	•	BQE8
* = previously Refr Techwoods, ** = previously, Morrison Techgrain. Names and codes in parenthesis () are names prior to 2009.				
V2 Natural Veneers				
Beech	FC	V311	•	B311
Bronzed Cherry	FC	V312	•	B312
Maple (Light Maple)	FC	V316	•	•
Mahogany on Beech	FC	V317	•	BQV317
Medium Cherry	FC	V319	•	BQV319
Medium Cherry on Beech	FC	V321	•	BQV321
Medium Walnut on Beech	FC	V322	•	BQV322
Light Walnut	FC	V411	•	BQV411
Peacock Green Walnut	FC	V415	•	BQV415
Old English Walnut	FC	V417	•	BQV417
Smoked Walnut	FC	V418	•	BQV418
Chalk Oak	RC	V421	QV421	•
Light Oak	RC	V423	QV423	•
Amber Oak	RC	V425	QV425	•
Brown Oak	RC	V427	•	BQV427
Light Fawn Cherry	FC	V433	•	BQV433
Medium Brown Cherry	FC	V436	•	BQV436
Straight Anigre	QC	V439	QV439	•
V3 Natural Exotic Veneers				
Figured Anigre	QC	V512	QV512	•
Graphite Oak	RC	V513	•	BQV513
Makore	QC	V514	•	BQV514
Figured Sycamore	QC	V515	•	•
Sapele	QC	V517	•	BQV517
Propeller Veneer Finishes				
American Cherry	FC	X	•	BQEX
Warm Brown Walnut	FC	J	•	BQEJ
Ebonized Walnut	FC	D	KE	BE

FC= Flat Cut Veneer, exhibits cathedral pattern

RC= Rift Cut Veneer, Straight Grain

QC = Quarter Cut Veneer, Straight Grain

• = Not possible

KnollStudio Natural Materials

Wood, marble, granite, and slate are natural materials that vary. Use material samples and printed sample materials as reference only.

KnollStudio printed and finish samples offer an example of what an “average” natural material may look like, within a range of acceptance carefully delineated by Knoll.

Because of the breadth of variations possible with any natural material, Knoll specialists select these materials with stringent criteria, accepting only the top 3 - 5% of what is available.

Wood*Knoll Natural Veneers*

All natural finishes are selected from the finest hardwoods available around the world. Veneers are flat cut and carefully matched so that cathedral or heart patterns are perfectly balanced. Natural veneers also are cut to allow a generous margin of quarter-grain figuring ensuring invisible splicing.

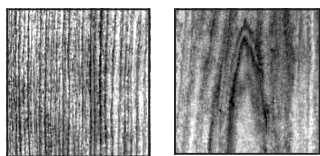

*Quarter
Pattern*

*Cathedral
Pattern*

Knoll Techgrain®

Knoll Techgrain is a veneer product that eliminates the inherent disparities in pattern, color and texture that characterize natural wood veneers. The consistency of Techgrain is important for uniformity. All KnollStudio Techgrains are non-figured and feature a regular, homogenous pattern.

The Techgrain process begins with wood veneers vat-dyed in natural vegetable mineral solines to create a perfectly clear, integrated color throughout. The veneer is finish coated with a clear water-white catalyzed varnish, a polymer finish which helps resist staining and marring. The result is a handsome surface with the appearance of a hand-rubbed oil finish.

Finishes

Most finishes are designed to coordinate with standard Morrison and Reff. For reference, consult the matrix on page 25.

Laminated Plywood (Cirene)

De Padova laminated plywood shells are made of the world's top 3-5% veneers available. The unique lamination process allows for an extremely thin yet sturdy shell with unmatched flexibility and dimensionality. Shells are natural veneer.

Marble, Granite and Slate

Knoll selects the highest quality, structurally sound marble, granite and slate available, through a host of quarries in Africa, South America, Greece, Turkey, Spain, Slovenia and Italy. Because each mountain range and quarry have their own signature, every marble piece - even within a single quarry - is unique. Hues, veins, crystals, fossils, clouds, and distinctive marks will vary from piece to piece. This is the extraordinary character of stone as a material. Below are the marbles, granites, travertines, and slates that KnollStudio offers:

Coated Marbles*Coated Marbles*

Coated marbles have transparent, high-polish, polyester coating to prevent use-associated stains. Even with this protection, coated marbles should not be used outdoors. Stains should be wiped immediately. Coating will yellow over time.

Satin Coated Marble

Satin coated marbles have transparent satin polyester coating to prevent use-associated stains. This satin finish gives the stone a natural, honed appearance while providing the same protective qualities as the Coated Marbles. Even with this protection, satin coated marbles should not be used outdoors. Stains should be wiped immediately. Coating will yellow over time.

Arabescato

Ivory white with dark grey veining. May contain random green veins.

Calacatta

Ivory white. Gold and beige random veins with additional veins varying from cream to green and grey.

Carrara

White background with grey veining.

Emperador Dark

Dark Brown with light brown and white veining. Natural finished stones will contain open fissures and pin-holes, which is considered a natural desirable trait.

Empire Beige

Yellowish-cream with yellow and rose colored veining and fissures.

Grey Marble

Grey with black and white veins. Hues vary in tone and intensity.

Nero Marquina

Rich black with random veins that can vary from white to gold.

Verde Alpi

Green. Black and white veins. Hues vary in tone and intensity.

Natural Marbles

Natural marbles have a protective sealer to protect the stone from aging and staining. Sealer has to be renewed periodically (see product maintenance on page 28). Natural marbles are not suitable for outdoor use.

Carrara

White background with grey veining.

Calacatta

Ivory white. Gold and beige random veins with additional veins varying from cream to green and grey.

Emperador Dark

Dark Brown with light brown and white veining. Natural finished stones will contain open fissures and pin-holes, which is considered a natural desirable trait.

Natural Granites

Natural granites have a sealer to protect the stone from aging and staining. Sealer has to be renewed periodically (see product maintenance on page 29). Because of its non-porous density, granite does not require protective polyester coatings.

Black Andes Granite

Black with reflective mica crystallines.

Slate

Natural cleft slate is available on Vignelli PaperClip Tables, SM Tables, and Saarinen Tables.

In combination with a weather-resistant base, PaperClip tables with slate tops are suitable for outdoor use. Please refer to respective product pages for recommended outdoor finish combinations.

Cane

A natural material, hand-woven for impeccable finish and smooth surface. Cane on Cesca chair has a light polyurethane coating for stain resistance.

Man-Made Materials & Finishes*Stainless Steel*

Completely rust-proof, highly durable, and resistant to bending stress.

Polished Chrome

Several-step plating process that includes a heavy layer of nickel for added rust protection and a bright mirror finish.

Satin Chrome

Chrome plating applied for a soft satinized chrome finish with a higher nickel content.

Nickel Finish

A warm, lustrous finish of nickel electroplate. Yellowish in color. Coated with clear lacquer to prevent oxidation.

Polished Aluminum

A shiny, polished finish.

Clear Anodized Aluminum

A light grey satin finish.

Fused Nylon Rilsan

A very durable and adhesive fused nylon-dipped finish. Scratch, chip, and chemical resistant. Appropriate for outdoor use.

Laminate/Color Core Laminate

An exceptionally durable plastic surface. Highly resistant to most chemicals and extensive wear.

Cotton Webbing

100% cotton unfinished webbing.

Cotton/Nylon Webbing

60% nylon, 40% cotton mixed yarns with silicone water-based protective coating.

Porcelain

An oven-baked finish on steel support with high durability.

Outdoor Powder Coat:

Durable outdoor powder finish that will provide excellent color and gloss retention with limited exposure to outdoor elements.

Painted, acid etched glass:

Clear glass with an acid etched top and painted underside. Polished and beveled edges surround.

Vetro Bianco:

Vetro Bianco is an engineered resin free quartz surface. The brilliant white surface is nonporous, stain proof, and extremely durable making it suitable for indoor and outdoor use.

With proper care, your KnollStudio furniture should last for years to come. To help ensure the longevity of your purchase, below are helpful hints on routine cleaning for your KnollStudio piece. Most basic maintenance can be performed with common household cleaning products.

Textiles

See KnollTextiles website for detailed cleaning and care instructions. Wipe all spills immediately. Brush and vacuum every three to four months. Use a foam upholstery cleaner as directed semi-annually, or more frequently if necessary. Try a hidden area to test for color fastness.

Spinneybeck Leathers

Leather is hardy and will adjust to its environment. It mellows gracefully with age. Leather is expected to change; even the oils from our hands help to develop the patina.

Full grain, aniline leather is undemanding. It breathes, has a life of its own, and requires little care. It should not be abused by harsh cleaners, or substances such as wax or mink oils which will clog the pores. A periodic wipe with a damp cloth is a sufficient means of cleaning under normal conditions.

Spinneybeck now offers a leather maintenance kit specifically designed for the 28 quantities offered. The kit includes a cleaner, conditioner and ink-remover and can be ordered by calling 1 800 482-7777. There are three types of kits:

- finished products
- full aniline products
- brush-sueded products

The following guidelines will help you to maintain the beauty of the leather without destroying any of its natural characteristics.

Naked Leather (Capri, Cervo, Copenhagen, Cordovan, Distressed, Prima, Saddle)

Naked leathers contain no foreign substances that act as a barrier against spillage or staining. They should be selected with this in mind.

The only recommended cleaning method for naked leather is to wipe the entire surface with a soft woolen cloth and water. Do not spot rub for it will darken only that area. The idea is to even out any abrasions or stains.

With use, naked leather develops a beautiful patina that removes many small scratches and abrasions as body oils moisturize and revitalize the leather. Substantial body oil marks will also dissipate over time, particularly if rubbed down with cool water.

Protective Finished Leathers (Acqua, Alaska, Amazon, Andes, Antique, Arizona, Derby, Ducale, España, Forte, Hand Tipped, Portofino, Riva, Sabrina, Salon, Torello, Velluto Pelle, Vicenza, Volo)

For high traffic use, breathable protective finish allows leather not only to be practical but also easy to maintain. It can be cleaned by wiping the entire surface with a soft cloth and a very mild solution of Ivory Flakes and cold water, followed by wiping the entire surface with water alone.

Grain Sueded Leather (Ducale Velour, Marissa)

For maximum soil resistance and durability these leathers have received an impregnated soil resistant treatment in the drum which permeates the leather making it repellent to liquid and dirt.

Grain sueded leather can be maintained with moderate care because spillage will bead and roll off. However, spillage should not be allowed to puddle, and should be blotted dry immediately. For normal care, leather should be brushed occasionally, with a sueded cleaning block to help remove general soilage.

If you have further questions about the care and maintenance of Spinneybeck leather, call Spinneybeck Customer Service at 800 482-7777.

Cowhide Slings, Belting Leather

For normal cleaning, use a soft cloth dampened with a solution of mild soap or detergent (Ivory Flakes) well dissolved in water. Rub very lightly, never pressing hard. Do not use solvents because dye may run. For scratches, use liquid shoe polish and buff when dry. Any liquids spilled on leather should be mopped up as soon as possible in order to avoid being absorbed by the leather.

Natural Caning

Use water and glycerin every three months to keep cane from drying out.

Vinyl

Clean frequently with a mild detergent and water. Use leather or plastic cleaners for unusually heavy use. Do not use solvents such as gasoline because plastic surface will gum and deteriorate.

Wood

Clean with a commercial brand of liquid furniture polish twice a month. For stubborn dirt or light scratches, rub lightly with very fine steel wool before using furniture polish. To rejuvenate luster, apply a furniture cream as a last step. Do not use water or household solvents: they will destroy the protective finish.

Lacquer Finishes on Wood (Florence Knoll credenza)

Frequent cleaning recommended: once per week with heavy use or once per month with light use. Clean with ordinary household soaps or detergents, well dissolved in water. Polish with lemon oil using a very soft cloth. For stubborn dirt or light scratches, uniformly apply Cleanbright Liquid Ebony or Guardsman liquid furniture polish with cheesecloth. Allow ten minutes to dry and wipe with a clean, dry cloth. For nicks, chips, and deep scratches, contact a professional refinisher. Never use abrasives.

Teak

Do not apply teak oil if you are using your furniture outdoors. For teak furniture used indoors, wipe surface with soft cloth to remove dust. Apply thin layer of teak oil using a paint brush and wipe excess using a soft cloth. Oil can be applied every 3 months to maintain rich color.

Wood Frame Chairs

Clean with dry and soft cloth. Rub smoothly with damp, lukewarm cloth. Treat stubborn stains with household soap solution or a solution with dishwashing liquid. Wipe off with clean, dry cloth. Do not use acid or abrasive detergents.

Marble with Polyester Coating

Wash with lukewarm water. Wash more thoroughly with Windex, Fantastik, Ivory Flakes in warm water, or other non-abrasive solutions. Rinse with warm water and dry with a soft cloth.

Natural Marbles/Marbles without Polyester Coating

Cleaning: Wipe off stains and liquid spills immediately with water and soft cloth. Never use steel wool or other abrasives on marble.

Maintenance: The mineral surface of marble is very porous and easily absorbs moisture and fluids causing staining and discoloring. If applied on a yearly basis, impregnators or penetrating sealers protect the interior of the stone, inhibit discoloration and allow the stone to breathe and release water vapor.

To restore a uniform luster, clean surface from any grit or debris, then remove all topical coatings with Stoneguard Stripper. Use Marblex to rinse surface, then let top dry for twelve hours before applying stone impregnator. Apply SCI Impregnator using a clean and dry applicator brush. After five minutes, wipe off the excess with soft, white terry cloth. If impregnator is absorbed within five minutes apply second coat at least twelve hours later.

Never use steel wool or other abrasives on marble.

Slate

Apply a generous amount of soap solution (1:5) to the table top with a hard brush. Wipe off the top with a clean, damp cloth. Repeat as often as required. Apply mineral oil or lemon oil as needed to protect surface and maintain color.

Granite

Clean with Windex, Fantastik, or other non-abrasive solutions on a regular basis. Apply a marble wax to improve luster and protect finish. Routine maintenance will prevent the stone from darkening with use from body oils, and will help maintain an evenness of color.

Vetro Bianco

Wash surface with lukewarm water. Clean more thoroughly with a non-abrasive solution such as Windex or Fantastik. Rinse with warm water and dry with a soft cloth. Wipe off stains immediately with water and a soft cloth. Never use steel wool or other abrasives on surface.

Glass/Acrylic Polycarbonate

Clean with Windex, Fantastik or other non-abrasive cleaning solutions. Wipe dry with a clean cloth.

Laminate/Melamine

Scrub with Windex, Fantastik, Mr. Clean, or other household soaps or detergents well dissolved in water, or with a very soft cloth dampened with alcohol or a synthetic thinner. For a dull finish, rub with jeweler's rouge as a polishing agent and finish with paste wax. Never use abrasives. Remove stubborn stains with Soft Scrub.

Stainless Steel

Use Windex, Fantastik, or other non-abrasive household cleaners. For small scratches, rub with Comet, Ajax, or other mild abrasives in the direction of the grain. Apply a coat of auto wax to maintain beauty.

Chrome/Satin Chrome

Clean with Windex or an automotive chrome cleaner such as Semi-Chrome twice a month. Apply a coat of hard paste wax to protect against moisture.

Nickel

Clean with Windex, Fantastik, or other non-abrasive cleaning solutions. If discoloration occurs, rub lightly with a fine steel wool to restore luster. Steel wool Grade #0000 is recommended. Touch-up with a clear lacquer to prevent oxidation.

Copper (uncoated)

Polish using a soft cloth and metal polish cream such as BlueMagic®. Do not use harsh abrasive or steel wool.

Polished Aluminum

Clean with Windex, Fantastik, or other non-abrasive cleaning solutions. Coat with a hard paste wax semi-annually to maintain luster and prevent discoloration.

Anodized Aluminum

Clean with mild soaps, detergents, or other non-abrasive cleaning agents. Apply paste wax or DuPont non-abrasive car polish #7 twice a year to prevent oxidation.

For stubborn stains or discolorations, apply navel jelly aluminum cleaner.

Urethane Edge

Clean with household soaps and detergents well dissolved in water. Do not use abrasive cleaning solutions.

Epoxy

Clean with Windex, Fantastik, or other ordinary non-abrasive household soaps, detergents, or ammonia at least once a month to prevent yellowing. For scratches and chips, rub with Comet, Ajax, or other mild abrasives. For deeper scratches, contact Knoll Customer Service for touch-up paint. Shine with a high grade auto polish. Never use harsh abrasives or steel wool.

Rilsan

Clean with Windex, Fantastik, or other ordinary non-abrasive household soaps or detergents. For ink stains on white surfaces, use Soft Scrub. For scratches and chips, rub with Comet, Ajax, or other mild abrasives. For deeper scratches, use a good grade automotive acrylic-lacquer touch-up paint. Shine with a high grade auto polish. Never use harsh abrasives or steel wool.

Porcelain

Clean with damp cloth using water or Windex. Do not use any abrasive detergent.

Powder Coat Paint

Clean with Windex or Endust using a soft cloth. Remove stubborn stains with Soft Scrub.

Polyester Shell

Clean with Windex or soap and water. Do not use any abrasive detergent.

Plastic Seat Shells

Clean with damp cloth with diluted soap. Wipe dry with clean cloth. Do not use any abrasive or acid detergents.

Cotton Webbing

Use damp cloth to clean. Do not use detergent or soap or any abrasive detergent.

Cotton/Nylon Webbing

Use damp cloth to wipe off stains.

Moving Parts

Lubricate moving parts every six months.

Swivel Mechanism

Apply a paste-type grease to swivel mechanism once a year.

Plastic/Polyethelene

Clean using a soft rag, either dry or wet. When needed, use mild pH-balanced soap diluted in water. Do not use abrasives sponges, acidic products or solvents containing ammonia.

To remove scuff marks, lightly rub scuff mark with a dry, non-scratch scour pad, like Scotch-Brite.

An assortment of our most popular products are available to ship in twenty working days:

Scope:

The KnollStudio 20-Day program offers a selection of products, finishes and upholstery materials for KnollStudio products only. 20-Day products and finishes are denoted by a helicopter () on the relevant page of the price list. See page 31 for a list of products and finishes, and maximum order quantities that are available within the 20-Day program.

Knoll will upholster 20-Day pieces in any approved KnollTextile or Spinneybeck leather that is in stock in sufficient quantity at time of order entry if not denoted otherwise. To check availability, call 1-800-523-0346 for KnollTextiles and 1-800-482-7777 for Spinneybeck leathers or contact your KnollStudio sales representative.

The upholstery scope listed below represents KnollTextiles and Spinneybeck leathers that are guaranteed to be in stock to support upholstered pieces on the 20-Day program unless noted otherwise in the upholstery column on page 31.

Availability:

20-Day orders can be fulfilled pending availability. Before specifying a 20-Day order, please check the lead time sheet on Knoll Exchange or contact your KnollStudio sales or customer resources representative to ensure availability.

Maximum order quantities are listed on page 31. Please check with your customer resources representative for availability of larger quantities.

For specific terms and conditions, consult the Knoll Selling Policy on pages 412-413.

Specification Guidelines:

20-Day orders should contain the following:

- Orders should be specified separately from standard lead time orders. Separate delivery charges may apply.
- A special prefix is required for 20-Day items. Please make sure all 20-Day items are marked with a “KS” prefix, as outlined on page 31.
- Full payment is required, including applicable tax and delivery fees.
- No changes or cancellations are allowed.
- 20-Day products are only available in the continental United States and Canada.

 KnollStudio 20-Day Program Upholstery Scope

Knoll will upholster 20-day pieces in any approved KnollTextile or Spinneybeck leather that is in stock at the time of order entry. To check availability, call 1-800-523-0346 for KnollTextiles or 1-800-482-7777 for Spinneybeck leathers, or contact your KnollStudio customer resources representative. The textile and leather selection listed below are reserved for the 20-day quickship program and are most likely to be instock at time of order entry.

KnollTextiles

Spinneybeck Leather

Grade A:	Grade B:	Grade C:	Grade G:	Grade U:
<p><i>Common Ground K448</i> 15 colorways, Teflon soil and stain repellent, 100% nylon content</p> <p><i>Mariner K642</i> 8 colorways, 100% nylon content</p>	<p><i>Vinyl K242</i> 10 colorways, outdoor approved, 100% vinyl face, backing 6% polyester, 91% vinyl, 3% cotton content</p>	<p><i>Classic Boucle K162</i> 13 colorways, 48% nylon, 52% wool content</p>	<p><i>Ultrasuede K1021</i> 21 colorways, high performance, stain resistant, 100% Polyester Ultra Microfiber content</p>	<p><i>Volo</i> Black (BLK) Toast(903)</p>

<i>Product</i>	<i>Code</i>	<i>Finish</i>	<i>Upholstery</i>	<i>Max. qty. per order</i>	<i>Page</i>
Side Chairs, Barstools and Lounge Seating					
Bertoia side chair	420C-C	Chrome	unupholstered	10	52
Bertoia side chair	420C-C-K	Chrome	In stock upholstery	10	52
Bertoia counter height stool	427C-C	Chrome	unupholstered	5	58
Bertoia counter height stool	427C-C-K	Chrome	In stock upholstery	5	58
Bertoia bar height stool	428C-C	Chrome	unupholstered	5	56
Bertoia bar height stool	428C-C-K	Chrome	In stock upholstery	5	56
Bertoia Diamond chair	421L-C-K	Chrome	In stock upholstery	5	62
Bertoia Seat cushions	420K, 427K, 428K		In stock upholstery	5	52
Wassily chair	50L-BLBLCK 50L-BL1905	Black or Red Spinneybeck Belting Leather		2	98
Spark side chair	4-C-SD-N	Red, Blue, Citron, Light Grey, Dark Grey, Recycled Black	unupholstered	25	100
Spark lounge chair	4-C-LG-N	Red, Blue, Citron, Light Grey, Dark Grey, Recycled Black	unupholstered	25	100
Chip armless chair	23C	Chrome Base, White, Birch, Grey		10	140
Sprite armless chair	27C	Chrome base, Black, White, Maple, solid front and back only		10	162
Gigi armless chair	87C	White, Graphite, Black, Red, Navy		25	168
Gigi arm chair	87A	White, Graphite, Black, Red, Navy		10	168
Gigi barstool, counter height	87CM	White, Graphite, Black, Red, Navy		10	180
Gigi barstool, bar height	87CH	White, Graphite, Black, Red, Navy		10	180
Barcelona chair	250LC	Chrome	Volo Black (VO BLK)	2	192
Barcelona ottoman	251YC	Chrome	Volo Black (VO BLK)	2	192
Toledo chair	29C			10	204
Spoletto chair	50CS-BLBLCK	Black belting leather		2	282
Womb chair	70L-C	Chrome Base	Classic Boucle/Pearl Classic Boucle/Cayenne	2	252
Womb ottoman	74Y-C	Chrome Base	Classic Boucle/Pearl Classic Boucle/Cayenne	2	252
Tables					
Albini desk	80D-E	Ebonized		1	292
Laccio side table	50T1	Black, white		2	296
Laccio coffee table	50T2	Black, white		2	296
D'Urso square work table	6348	In stock laminate, black legs, glides		10	298
D'Urso round work table	6242	In stock laminate, black legs, glides		10	300
D'Urso racetrack work table	6472	In stock laminate, black legs, glides		10	304
Florence Knoll tables	2510T-C-G2 2511T-C-G2	Chrome base, glass top		2	324
Pensi café table	29TS-35-DE 29TR27-DE 29TR-39-DE	Disks		3	350
Arena round café table	23TR36-C-W	Chrome base, white top		3	354
Barcelona table	252C	Chrome base, clear glass top		1	336
MR table	259TS-G			2	336
Cyclone dining table	311-F2	White top		1	348
Platner side and coffee tables	3710T-N-G2	Nickel base, clear glass top		2	356
	3710T-BRM-G2	Bronze base, clear glass top		2	356
	3712T-BRM-G2				
	3714-BRM-G2				
	3710T-BRM-BRG	Bronze base, bronze glass top		2	356
	3712T-BRM-BRG				
	3714T-BRM-BRG				

<i>Product</i>	<i>Code</i>	<i>Finish</i>	<i>Upholstery</i>	<i>Max. qty. per order</i>	<i>Page</i>
Tables, continued					
Saarinen dining tables	173TR-F2-2 176TR-F2-2 164TR-F2-2	Laminate top, white base		2	366
Saarinen side and coffee tables	169TR-LO-2 169TR-F2-2 163TR-F2-2	Light oak top, white base White laminate top, white base White laminate top, white base		1	374

Please see pages 30 and 33 for more information on placing a KnollStudio 20-Day order.

Use the Following Address:

If you would like to send an order directly to our order entry departments, please use the following address:

Knoll, Inc.
P.O. Box 157
East Greenville, PA 18041
Attn: Order Entry

Fax: 215 679-1570
Tel: 800 343-KNOLL

When Placing Your Order, Include:

- All information requested on the order form.
- Local taxes for the “delivered to” address.
- For orders \$2,000 or under (including applicable taxes and delivery/installation fees, if any), full payment must be made when order is placed.
- For orders over \$2,000, a deposit equal to one-half of the complete order value is required at order placement. Balance must be settled before shipment.
- For 20-day orders, please adhere to the specification guidelines on page 30.

Key Points to Remember:

All accepted orders will be confirmed in writing on the Knoll standard acknowledgement form. A copy of the acknowledgement will be mailed to the customer prior to production.

Freight within the 48 contiguous United States and Canada, excluding the Yukon, Northwest Territories and Newfoundland, is prepaid and included in the price of all orders.

For residential orders, Knoll strongly recommends White Glove delivery service to most locations in the Continental United States and Canada. White Glove service includes inside delivery, unpacking, furniture installation and removing cartons and crates. The fee for this service will be quoted at the point of purchase.

KnollStudio’s limited warranty covers all furniture against manufacturing defects in this price list for a period of five years after delivery to the customer.



All pricing is in U.S. dollars.

For More Information:

For complete Knoll Selling Policy and warranty information, please refer to pages 412-413 in the back of this price list.

For additional information on KnollStudio, contact your KnollStudio representative, a Knoll Space retailer or e-tailer, or telephone Customer Services at 800 343-KNOLL. To find the retailer or showroom nearest you, visit www.knoll.com.

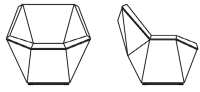
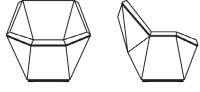
David Adjaye
The Washington Collection for Knoll™
Prism™ Lounge Chair and Ottoman

	description	w	d	h	height, seat	textile fabric yards
<i>Designer(s):</i> David Adjaye, 2014 <i>Award(s):</i> Editors Choice Award, Lounge Furniture Collection, NeoCon June 2015, USA; Metropolis Likes Award, Metropolis Magazine, June 2015, USA	WL21F Lounge Chair, fixed base 	33 1/4"	31 1/2"	31 1/2"	16 1/4"	2
	WL21S Lounge Chair, swivel base 	33 1/4"	31 1/2"	31 1/2"	16 1/4"	2
	WL23 Ottoman 	26 3/4"	17"	16 3/4"	15 1/2"	1









pattern no.	A	B	C	D	E	F	G	H	I
WL21F-(-)	\$15,099.	\$15,144.	\$15,196.	\$15,257.	\$15,342.	\$15,391.	\$15,477.	\$15,534.	\$15,706.
WL21S-(-)	15,556.	15,602.	15,653.	15,714.	15,799.	15,849.	15,935.	15,992.	16,164.
WL23-(-)	7,806.	7,828.	7,854.	7,885.	7,927.	7,952.	7,994.	8,024.	8,109.

Order Code	Ordering Information	Construction
<i>Example:</i> WL21S-111G-K1882/9 WL21S Lounge, swivel 111G Black base K1882/9 Melange/Onyx	<i>Base finishes:</i> Black (suffix 111G) White (suffix 118G) Red (suffix 845G) <i>Maintenance:</i> See pages 28-29.	<i>Base:</i> Constructed of 3/4" Baltic Birch plywood panels covered in a plastic color core laminate which maintains color throughout so vibrancy is maintained from edge to edge. Panels are assembled together using poplar wood corner blocks. <i>Upholstery:</i> Textile upholstered over individual panels of urethane molded foam. All upholstery will feature a black leather welt along the edges where the base and upholstery meet. <i>Note:</i> Swivel base returns to center.

- Specify:*
1. Pattern number
 2. Base finish selection
 3. Textile selection

Approved KnollTextiles Grades/Fabrics		
A Hourglass Sonnet	C Circa Classic Boucle	G Haze Melange Ultrasuede
B Cameo Chroma Journey Keaton Knoll Felt Knoll Hopsack Ransom Synth	F Atelier Calais Cotton Velvet Cornaro Rivington	H Arno Magritte
<i>Check with your KnollTextiles Representatives for changes or additions.</i>		

David Adjaye
The Washington Collection for Knoll™
Skin™ and Skeleton™ Chair

	description	seat h	w	d	h	weight
<i>Designer(s):</i> David Adjaye, 2013	WS2CN Washington Skin™ nylon chair	17 1/2"	18"	20 1/4"	32 1/2"	13 lbs.
<i>Award(s):</i> 2014 Design Guild Mark Best of NeoCon Gold Award 2014						
	WS1CA Washington Skeleton™ painted aluminum chair	17 1/2"	18"	20 1/4"	32 1/2"	20 lbs.
						
	WS1CA Washington Skeleton™ nickel plated aluminum chair	17 1/2"	18"	20 1/4"	32 1/2"	20 lbs.
						
	WS1CA Washington Skeleton™ copper plated aluminum chair, natural	17 1/2"	18"	20 1/4"	32 1/2"	20 lbs.
						
	WS1CA Washington Skeleton™ copper plated aluminum chair with ceramic coating	17 1/2"	18"	20 1/4"	32 1/2"	20 lbs.
						

pattern no.	
WS2CN-()	\$682.
WS1CA-()	1,113.
WS1CA-NO	2,250.
WS1CA-NCU	2,250.
WS1CA-CC	2,690.

Order Code	Ordering Information	Construction
<i>Example:</i> WS1CA-001	<i>Nylon finishes:</i> Black (suffix 011) White (suffix 012) Grey (suffix 013) Orange (suffix 015) Yellow (suffix 016) Lime (suffix 017)	<i>Nylon Chair:</i> Injection molded, glass reinforced nylon cantilevered chair. The chair's shell and legs are cast in three parts and are connected using mortise and tenon joinery and stainless steel fasteners. The unique leg design is reinforced internally with a cast aluminum brace. Features four integral glides that elevate and protect the leg profile.
WS1CA Aluminum chair	<i>Aluminum paint finishes:</i> Black (suffix 001) Grey (suffix 003) Green (suffix 007) White (suffix WHT) Sterling (suffix 906T)	<i>Aluminum Chair:</i> Constructed from die-cast aluminum, the chair's shell and legs are cast in three parts and connected using mortise and tenon joinery and stainless steel fasteners. Available in ultra-durable powder coat paint, a nickel plated finish, a natural copper plated finish that will patina with age and a copper plated finish with ceramic coating that will maintain the original copper finish and prevent patina. Features four nylon glides.
001 Black paint finish	<i>Aluminum, plated finish:</i> Copper, natural (suffix NCU) Copper, coated (suffix CC) Brushed Nickel (suffix NO)	<i>Note:</i> Copper plated chairs without the ceramic coating will patina with age. The Washington Skin and Washington Skeleton chairs are Greenguard certified.
<i>Specify:</i> 1. Pattern number 2. Paint finish selection	<i>Outdoor Use:</i> With proper maintenance painted aluminum chairs are appropriate for outdoor environments. <i>Maintenance:</i> See pages 28-29.	<i>Outdoor Use:</i> With proper care, the Washington Skeleton Chair in powder coat paint finishes is appropriate for outdoor environments.







Edward Barber & Jay Osgerby

Sofa Collection

Lounge Seating

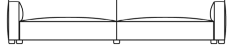
Designer(s):
Edward Barber and Jay Osgerby,
2013



description	seat h	arm h	w	d	h	textile fabric yds.	req. leather sq. ft.
BO2 Two Seat Sofa 	15 1/4"	25"	73 1/4"	40 1/4"	28 1/4"	10.7	220
BO3 Three Seat Sofa 	15 1/4"	25"	85"	40 1/4"	28 1/4"	13	240
BO4 Four Seat Sofa 	15 1/4"	25"	132 1/4"	40 1/4"	28 1/4"	14.9	330
BO5L Asymmetric Sofa, left 	15 1/4"	25"	102 1/4"	40 1/4"	28 1/4"	12.3	270
BO5R Asymmetric Sofa, right 	15 1/4"	25"	102 1/4"	40 1/4"	28 1/4"	12.3	270
BO15L Asymmetric Sofa with Left Chaise 	15 1/4"	25"	102 1/4"	66"	28 1/4"	13.9	310
BO15R Asymmetric Sofa with Right Chaise 	15 1/4"	25"	102 1/4"	66"	28 1/4"	13.9	310

Order Code	Ordering Information	Construction
<i>Example:</i> BO3-C-H800/19	<i>Base/Leg Finish:</i> Chrome (suffix C) Jet Black (suffix 111) Medium Metallic Grey (suffix 612) Red Coral (suffix CRL)	<i>Frame:</i> Hardwood and plywood construction with elastomeric suspension sheet webbing and foam supported sit-through feature at the cushion breaks.
BO3 Barber & Osgerby Three Seat sofa		<i>Stitching:</i> Pinched topstitched seaming.
C Polished chrome		<i>Legs:</i> Die cast aluminum legs with height adjustable glides.
H800/19 Cato, Fire Red	<i>Upholstery/COM information:</i> Prices shown include fabric or leather upholstery. Contact your Knoll representative for colors. Only approved KnollTextiles and Spinneybeck leathers may be ordered.	<i>Note:</i> Four Seat and Asymmetric Sofas come in two sections and are joined by a pin and socket locking mechanism in the joining leg.
<i>Specify:</i> 1. Pattern number 2. Base finish selection 3. Textile/leather selection	Customer's Own Material is available pending approval. For approval requirements, processing instructions and ordering information please see page 18. <i>Maintenance:</i> See pages 28-29.	<i>Upholstery:</i> High density foam construction throughout with gel infused high density memory foam on top seating surface. All textiles must be railroaded - including COMs. Asymmetric Sofa with Chaise: The fabric on the sofa will always run perpendicular to the fabric on the chaise as both pieces must railroaded. Therefore, only textiles with a solid color and a non-specific directional weave may be used. Approved fabrics are noted with an asterisk (*).

pattern no.	grades A	COM B	C	D	E	F	G	H	I	COL U	V	W	X	Y
BO2-(-)(-)	\$8,259.	\$8,511.	\$8,795.	\$9,132.	\$9,598.	\$9,870.	\$10,345.	\$10,661.	\$11,605.	\$15,486.	\$16,500.	\$18,563.	\$18,992.	\$19,493.
BO3-(-)(-)	9,500.	9,809.	10,152.	10,562.	11,129.	11,459.	12,035.	12,420.	13,567.	17,333.	18,439.	20,691.	21,160.	21,706.
BO4-(-)(-)	12,462.	12,815.	13,210.	13,678.	14,328.	14,707.	15,367.	15,808.	17,124.	23,291.	24,813.	27,908.	28,552.	29,303.
BO5L-(-)(-)	10,781.	11,072.	11,397.	11,784.	12,321.	12,634.	13,179.	13,542.	14,629.	19,750.	20,996.	23,528.	24,055.	24,669.
BO5R-(-)(-)	10,781.	11,072.	11,397.	11,784.	12,321.	12,634.	13,179.	13,542.	14,629.	19,750.	20,996.	23,528.	24,055.	24,669.
BO15L-(-)(-)	12,661.	12,991.	13,359.	13,796.	14,402.	14,754.	15,372.	15,782.	17,008.	21,405.	22,836.	25,743.	26,348.	27,054.
BO15R-(-)(-)	12,661.	12,991.	13,359.	13,796.	14,402.	14,754.	15,372.	15,782.	17,008.	21,405.	22,836.	25,743.	26,348.	27,054.

Approved KnollTextiles Grades/Fabrics	Spinneybeck Leather
A Crossroad Delite Hourglass * Mariner * Overture Presto * Sonnnet Uni-Form *	U Vicenza * Volo * V Acqua * Andes * Embossed Tipped * Espana * Velluto Pelle *
C Circa Classic Boucle * Lagos Pullman Spot On Star Struck Swing	W Antique * Alaska * Forte * Lucente * Sabrina * Umbria * Y Riva *
D Compass CR	
E Aegean * Highland *	
F Atelier Cornaro *	
G Alter Ego Haze Melange * Modern Tweed Petite Floral Ultrasuede *	
H Arno * Magritte *	
I Cato	
B Calypso Cameo Diva Helios Keaton Knoll Felt * Knoll Hopsack * Little Devil Melody Spark Summit Tinge	





*Approved for the Asymmetric Sofa with Chaise (BO15R, BO15L)

Check with your KnollTextiles or Spinneybeck Representative for changes or additions.

Edward Barber & Jay Osgerby

Sofa Collection

Lounge Seating

	description	seat h	arm h	w	d	h	textile fabric yds.	req. leather sq. ft.
<i>Designer(s):</i> Edward Barber and Jay Osgerby, 2013	BO6 Ottoman, small 			29 1/2"	29 1/2"	15 1/4"	2.1	45
	BO7 Ottoman, medium 			35 1/2"	35 1/2"	15 1/4"	2.5	60
								

pattern no.	grades A	COM B	C	D	E	F	G	H	I	COL U	V	W	X	Y
BO6-(-)(-)	\$2,802.	\$2,853.	\$2,907.	\$2,973.	\$3,065.	\$3,119.	\$3,212.	\$3,274.	\$3,459.	\$4,331.	\$4,538.	\$4,960.	\$5,047.	\$5,150.
BO7-(-)(-)	3,129.	3,189.	3,255.	3,333.	3,442.	3,506.	3,616.	3,690.	3,911.	5,180.	5,387.	5,809.	5,897.	6,000.

Order Code	Ordering Information	Construction
<i>Example:</i> BO3-C-H800/19	<i>Base/Leg Finish:</i> Chrome (suffix C) Jet Black (suffix 111) Medium Metallic Grey (suffix 612) Red Coral (suffix CRL)	<i>Frame:</i> Hardwood and plywood construction with elastomeric suspension sheet webbing and foam supported sit-through feature at the cushion breaks.
BO3 Barber & Osgerby Three Seat sofa		<i>Stitching:</i> Pinched topstitched seaming.
C Polished chrome		<i>Legs:</i> Die cast aluminum legs with height adjustable glides.
H800/19 Cato, Fire Red	<i>Upholstery/COM information:</i> Prices shown include fabric or leather upholstery. Contact your Knoll representative for colors. Only approved KnollTextiles and Spinneybeck leathers may be ordered.	<i>Upholstery:</i> High density foam construction throughout with gel infused high density memory foam on top seating surface. All textiles must be railroaded - including COMs.
<i>Specify:</i> 1. Pattern number 2. Base finish selection 3. Textile/leather selection	Customer's Own Material is available pending approval. For approval requirements, processing instructions and ordering information please see page 18. <i>Maintenance:</i> See pages 28-29.	<i>Note:</i> Four Seat and Asymmetric Sofas come in two sections and are joined by a pin and socket locking mechanism in the joining leg. All textiles must be railroaded - including COMs



Approved KnollTextiles Grades/Fabrics	Spinneybeck Leather
A Crossroad Delite Hourglass * Mariner * Overture Presto * Sonnet Uni-Form *	U Vicenza * Volo * V Acqua * Andes * Embossed Tipped * Espana * Velluto Pelle *
C Circa Classic Boucle * Lagos Pullman Star Struck Swing	W Antique * Alaska * Forte * Lucente * Sabrina * Umbria * Y Riva *
D Compass CR	
E Aegean * Highland *	
F Atelier Cornaro *	
G Alter Ego Haze Melange * Modern Tweed Petite Floral Ultrasuede *	
H Arno * Magritte *	
I Cato	
B Calypso Cameo Diva Helios Keaton Knoll Felt * Knoll Hopsack * Little Devil Melody Spark Summit Tinge	

*Approved for the Asymmetric Sofa with Chaise (BO15R, BO15L)
Check with your KnollTextiles or Spinneybeck Representative for changes or additions.

Edward Barber & Jay Osgerby

Sofa Collection

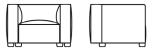
Compact Lounge Seating

	description	seat h	arm h	w	d	h	textile fabric yds.	req. leather sq. ft.	weight
<i>Designer(s):</i> Edward Barber and Jay Osgerby, 2013 	BOC1 Armchair	15 3/4"	25"	39 1/2"	33 3/4"	25"	5.9	125	
									
	BOC2 Two Seat sofa	15 3/4"	25"	64 1/2"	33 3/4"	25"	8.7	175	
									

pattern no.	grades A	COM B	C	D	E	F	G	H	I	COL U	V	W	X	Y
BOC1-(-)(-)	\$5,101.	\$5,242.	\$5,398.	\$5,583.	\$5,841.	\$5,990.	\$6,251.	\$6,426.	\$6,947.	\$9,351.	\$9,928.	\$11,100.	\$11,344.	\$11,628.
BOC2-(-)(-)	7,180.	7,387.	7,617.	7,892.	8,270.	8,492.	8,877.	9,133.	9,901.	13,235.	14,041.	15,682.	16,025.	16,423.

Order Code	Ordering Information	Construction
<i>Example:</i> BOC2-SGE-K1320/3		
BOC2 Barber & Osgerby Two Seat sofa	Base/Leg Finish: Chrome (suffix C) Jet Black (suffix 111) Medium Metallic Grey (suffix 612) Red Coral (suffix CRL)	Frame: Hardwood and plywood construction with elastomeric suspension sheet webbing and foam supported sit-through feature at the cushion breaks.
SGE Sage		Upholstery: High density foam construction throughout with gel infused high density memory foam on top seating surface.
K1320/3 Cornaro, Mist		Stitching: Pinched topstitched seaming.
<i>Specify:</i> 1. Pattern number 2. Base finish selection 3. Textile/leather selection	Upholstery/COM information: Prices shown include fabric or leather upholstery. Contact your Knoll representative for colors. Only approved KnollTextiles and Spinneybeck leathers may be ordered. Customer's Own Material is available pending approval. For approval requirements, processing instructions and ordering information please see page 18. Maintenance: See pages 28-29.	Legs: Die cast aluminum legs with height adjustable glides.

Approved KnollTextiles Grades/Fabrics				Spinneybeck Leather
A Crossroad Delite Hourglass Mariner Overture Presto Sonnet Uni-Form	C Circa Classic Boucle Lagos Pullman Spot On Star Struck Swing	D Compass CR	E Aegean Highland	U Vicenza * Volo *
B Calypso Cameo Diva Helios Keaton Knoll Felt Knoll Hopsack Little Devil Melody Spark Summit Tinge	F Atelier Cornaro	G Alter Ego Haze Melange Modern Tweed Petite Floral Ultrasuede	H Arno Magritte	V Acqua * Andes * Embossed Tipped * España *
			I Cato	W Antique * Alaska * Forte * Lucente * Umbria *
				X Sabrina * Y Riva *
				Check with your KnollTextiles or Spinneybeck Representative for changes or additions.

Edward Barber & Jay Osgerby
Sofa Collection
Pillows

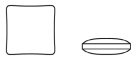
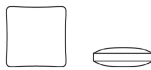
	description	w	d	textile fabric yds.	req. leather sq. ft.
<i>Designer(s):</i> Edward Barber and Jay Osgerby, 2013 	BO8P Pillow, small	19"	19"	1.9	25
					
	BO9P Pillow, large	23 1/2"	23 1/2"	2.6	30
					

pattern no.	A	B	C	D	E	F	G	H	I	U	V	W	X	Y
BO8P-()	\$556.	\$601.	\$652.	\$711.	\$795.	\$843.	\$927.	\$984.	\$1,150.	\$1,296.	\$1,412.	\$1,646.	\$1,695.	\$1,752.
BO9P-()	744.	806.	874.	957.	1,069.	1,136.	1,251.	1,327.	1,557.	1,606.	1,743.	2,025.	2,083.	2,152.

Order Code	Ordering Information	Construction
<i>Example:</i> BO8P-K1054/9	<i>Upholstery/COM information:</i> Prices shown include fabric upholstery only. Contact your Knoll representative for colors. Only approved KnollTextiles may be ordered.	<i>Fill:</i> Made from 90% feather and 10% down.
BO8P Small pillow		
K1054/9 Circa/Red		
<i>Specify:</i> 1. Pattern number 2. Textile selection	Customer's Own Material is not approved.	<i>Ticking:</i> 100% cotton.

Approved KnollTextiles Grades/Fabrics			
A Crossroad Delite Hourglass Mariner Overture Presto Sonnet Uni-Form	C Circa Classic Boucle Lagos Pullman Spot On Star Struck Swing	D Compass CR Woodland	G Alter Ego Haze Melange Modern Tweed Striae Stripe Ultrasuede
B Calypso Cameo Diva Helios Keaton Knoll Felt Knoll Hopsack Little Devil Melody Spark Tinge Zipline		E Highland Meroe	H Arno Magritte Stretch Appeal
		F Atelier Cornaro In Stitches Liberty	I Cato Ita

Edward Barber & Jay Osgerby

Pilot by Knoll® Lounge Collection

High Back

Designer(s):
Edward Barber and Jay Osgerby,
2014



description	seat h	arm h	w	d	h	Base Finish	textile fabric yds.	req. leather sq. ft.	weight
BO30-AL Pilot by Knoll® High Back Lounge Chair, Loop arm	16"	20"	27 1/4"	30 3/8"	39 3/8"	Dark Grey, painted	6	61	59 lbs.
	16"	20"	27 1/4"	30 3/8"	39 3/8"	Polished aluminum	6	61	59 lbs.
BO30-AU Pilot by Knoll® High Back Lounge Chair, Upholstered arm	16"	21 1/2"	27 1/4"	30 3/8"	39 3/8"	Dark Grey, painted	6	61	59 lbs.
	16"	21 1/2"	27 1/4"	30 3/8"	39 3/8"	Polished aluminum	6	61	59 lbs.
BO30-C Pilot by Knoll® High Back Lounge Chair, Armless	16"		23 3/8"	30 3/8"	39 3/8"	Dark Grey, painted	6	61	57 lbs.
	16"		23 3/8"	30 3/8"	39 3/8"	Polished aluminum	6	61	57 lbs.

Order Code	Ordering Information
<i>Example:</i> BO30-AL-3-K1523/25	<i>Base finishes:</i> Polished Aluminum (suffix P) Dark Grey paint (suffix 3)
BO30	Pilot by Knoll® High Back Lounge Chair
AL	Loop arms
3	Dark Grey, painted (base and arms)
K1523/25	Hourglass/Iron
<i>Specify:</i>	<i>Loop Arm finishes:</i> Loop with chrome brackets Black painted loop with dark grey painted brackets
1. Pattern number	<i>Loop Arm specification:</i> The selected base finish will automatically designate coordinating arm finish: Polished Aluminum base / Chrome loop arms Dark Grey painted base / Black loop arms with Dark Grey brackets
2. Arm option	
3. Base finish selection (loop arm finish will match base finish)	
4. Split upholstery (optional)	<i>Two or three split upholstery option:</i> Seat, back and upholstered arms can be specified in different fabrics or leathers. <u>Fabric and leather cannot be mixed.</u> Indicate S followed by the textile or leather for seat, back and arms (if applicable). For any split upholstery, price equals the higher seat or back upholstery grade plus \$150 upcharge. <u>Specification example:</u> Pattern number: BO30-AU-P-S-K-1882/8-K2063/3-K1579/5 High Back Lounge Chair, upholstered arms, polished aluminum base, split upholstery Seat textile: Melange/Flannel (Grade G) Back textile: Tivoli/Dove (Grade F) Arms textile: Tudor/Glacier (grade I) Price = Grade G + \$150 upcharge
5. Textile selection	<i>Upholstery/COM information:</i> Prices shown include fabric or leather upholstery. Contact your Knoll representative for colors. Only approved KnollTextiles and Spinneybeck leathers may be ordered. Customer's Own Material is available pending approval. For approval requirements, processing instructions and ordering information please see page 18. <i>Maintenance:</i> See pages 28-29.
	<i>COM split fabric requirements:</i> Seat: 2.4 yards Back: 2.4 yards Arms: 1.2 yards
	<i>COL split leather requirements:</i> Seat: 19 square feet Back: 28 square feet Arms: 14 square feet

pattern no.	grades A	COM B	C	D	E	F	G	H	I	COL U	V	W	X	Y
BO30-AL-3-()	\$4,006.	\$4,092.	\$4,216.	\$4,315.	\$4,459.	\$4,585.	\$4,727.	\$4,836.	\$5,327.	\$5,981.	\$6,271.	\$6,891.	\$7,100.	\$7,465.
BO30-AL-P-()	4,239.	4,325.	4,449.	4,548.	4,691.	4,817.	4,959.	5,069.	5,560.	6,213.	6,504.	7,123.	7,332.	7,698.
BO30-AU-3-()	4,351.	4,438.	4,561.	4,660.	4,804.	4,930.	5,072.	5,181.	5,673.	6,420.	6,710.	7,330.	7,538.	7,904.
BO30-AU-P-()	4,481.	4,568.	4,691.	4,791.	4,934.	5,060.	5,202.	5,311.	5,803.	6,550.	6,840.	7,460.	7,668.	8,035.
BO30-C-3-()	3,481.	3,567.	3,691.	3,790.	3,934.	4,060.	4,202.	4,311.	4,802.	5,396.	5,687.	6,306.	6,515.	6,880.
BO30-C-P-()	3,611.	3,698.	3,821.	3,920.	4,064.	4,190.	4,332.	4,441.	4,932.	5,526.	5,817.	6,436.	6,645.	7,011.

Construction	Approved KnollTextiles Grades/Fabrics	Spinneybeck Leather
<i>Base:</i> Four star, cantilevered, 360° swivel, die cast aluminum base, available polished or painted in a highly durable powder coat.	A Common Ground Delite Dristi Hourglass Mariner Overture Presto Sonnet	U Vicenza Volo V Acqua Andes España Velluto Pelle
<i>Upholstery:</i> Highly resilient polyurethane molded foam, overlaid with knit backed polyester fiber. Top stitched, open parallel double side seaming.	B cont. Ransom Summit Tinge Utmost Venue Vinyl Westwood	W Alaska Antique Forte Sabrina Umbria
<i>Substructure:</i> Comprised of steel, die cast aluminum and elastic webbing embedded inside polyurethane molded foam.	C Calypso Cameo Chroma Diva Ferry Forza Helios Journey Keaton Knoll Felt Knoll Hopsack Ludlow Melody Prairie	Y Copenhagen Marissa Riva Saddle
<i>Arms:</i> <u>Loop Arms:</u> steel rod loop arms and die cast aluminum arm brackets. <u>Upholstered Arms:</u> steel weldment substructure embedded inside highly resilient polyurethane molded foam, overlaid with knit backed polyester fiber.	D Woodland E Demure Highland Whip F Atelier Cornaro Rivington Tweed Frieze	H Haze Melange Petite Floral Ultrasuede I Arno Tudor

Check with your KnollTextiles or Spinneybeck Representative for changes or additions.

Edward Barber & Jay Osgerby

Pilot by Knoll® Lounge Collection

Low Back

Designer(s):
Edward Barber and Jay Osgerby,
2014



description	seat h	arm h	w	d	h	Base Finish	textile fabric yds.	req. leather sq. ft.	weight
BO31-AL Pilot by Knoll® Low Back Lounge Chair, Loop arm	16"	20"	27 1/4"	27 1/2"	31 7/8"	Dark Grey, painted	5.5	57	57 lbs.
	16"	20"	27 1/4"	27 1/2"	31 7/8"	Polished aluminum	5.5	57	57 lbs.



BO31-AU Pilot by Knoll® Low Back Lounge Chair, Upholstered arm	16"	21 1/2"	27 1/4"	27 1/2"	31 7/8"	Dark Grey, painted	5.5	57	57 lbs.
	16"	21 1/2"	27 1/4"	27 1/2"	31 7/8"	Polished aluminum	5.5	57	57 lbs.



BO31-C Pilot by Knoll® Low Back Lounge Chair, Armless	16"		23 3/8"	27 1/2"	31 7/8"	Dark Grey, painted	5.5	55	55lbs.
	16"		23 3/8"	27 1/2"	31 7/8"	Polished aluminum	5.5	55	55lbs.

Order Code

<i>Example:</i>	BO31-AL-3-K1523/25
BO31	Pilot by Knoll® Low Back Lounge Chair
AL	Loop arms
3	Dark Grey, painted (base and arms)
K1523/25	Hourglass/Iron

Specify:

1. Pattern number
2. Arm option
3. Base finish selection (loop arm finish will match base finish)
4. Split upholstery (optional)
5. Textile selection

Ordering Information

Base finishes:
Polished Aluminum (suffix P)
Dark Grey paint (suffix 3)

Loop Arm finishes:
Loop with chrome brackets
Black painted loop with dark grey painted brackets

Loop Arm specification:
The selected base finish will automatically designate coordinating arm finish:
Polished Aluminum base / Chrome loop arms
Dark Grey painted base / Black loop arms with Dark Grey brackets

Two or three split upholstery option:
Seat, back and upholstered arms can be specified in different fabrics or leathers. Fabric and leather cannot be mixed. Indicate **S** followed by the textile or leather for seat, back and arms (if applicable).

For any split upholstery, price equals the higher seat or back upholstery grade plus \$150 upcharge.
Specification example:
Pattern number:
BO31-AU-P-S-K-1882/8-K2063/3-K1579/5
Low Back Lounge Chair, upholstered arms, polished aluminum base, split upholstery
Seat textile: Melange/Flannel (Grade G)
Back textile: Tivoli/Dove (Grade F)
Arms textile: Tudor/Glacier (grade I)
Price = Grade G+ \$150 upcharge

COM split fabric requirements:
Seat: 2.4 yards
Back: 1.9 yards
Arms: 1.2 yards

COL split leather requirements:
Seat: 19 square feet
Back: 22 square feet
Arms: 14 square feet

Upholstery/COM information:
Prices shown include fabric or leather upholstery. Contact your Knoll representative for colors. Only approved KnollTextiles and Spinneybeck leathers may be ordered.

Customer's Own Material is available pending approval. For approval requirements, processing instructions and ordering information please see page 18.

Maintenance:
See pages 28-29.

pattern no.	grades A	COM B	C	D	E	F	G	H	I	COL U	V	W	X	Y
BO31-AL-3(-)	\$3,751.	\$3,831.	\$3,945.	\$4,035.	\$4,167.	\$4,282.	\$4,413.	\$4,512.	\$4,964.	\$5,546.	\$5,808.	\$6,366.	\$6,555.	\$6,884.
BO31-AL-P(-)	3,984.	4,064.	4,177.	4,268.	4,400.	4,515.	4,645.	4,745.	5,196.	5,778.	6,040.	6,599.	6,787.	7,116.
BO31-AU-3(-)	4,126.	4,206.	4,319.	4,410.	4,542.	4,657.	4,787.	4,887.	5,338.	5,970.	6,232.	6,791.	6,979.	7,308.
BO31-AU-P(-)	4,256.	4,336.	4,449.	4,540.	4,672.	4,787.	4,917.	5,017.	5,468.	6,100.	6,362.	6,921.	7,019.	7,438.
BO31-C-3(-)	3,231.	3,311.	3,425.	3,515.	3,647.	3,762.	3,893.	3,993.	4,444.	4,961.	5,223.	5,782.	5,970.	6,299.
BO31-C-P(-)	3,362.	3,441.	3,555.	3,646.	3,777.	3,893.	4,023.	4,123.	4,574.	5,091.	5,353.	5,912.	6,100.	6,429.

Construction

Base:
Four star, cantilevered, 360° swivel, die cast aluminum base, available polished or painted in a highly durable powder coat.

Upholstery:
Highly resilient polyurethane molded foam, overlaid with knit backed polyester fiber. Top stitched, open parallel double side seaming.

Substructure:
Comprised of steel, die cast aluminum and elastic webbing embedded inside polyurethane molded foam.





Arms:
Loop Arms: steel rod loop arms and die cast aluminum arm brackets.
Upholstered Arms: steel weldment substructure embedded inside highly resilient polyurethane molded foam, overlaid with knit backed polyester fiber.

Approved KnollTextiles Grades/Fabrics

A Common Ground	B continued	D Woodland	G Haze	U Vicenza	W Alaska
Delite	Ransom		Melange	Volo	Antique
Dristi	Summit		Petite Floral		Forte
Hourglass	Tinge	E Demure	Ultrasuede	V Acqua	Sabrina
Mariner	Utmost	Highland		Andes	Umbria
Overture	Venue	Whip	H Arno	Espana	
Presto	Vinyl			Velluto Pelle	Y Copenhagen
Sonnet	Westwood	F Atelier	I Tudor		Marissa
		Cornaro			Riva
	C Atlas	Rivington			Saddle
	Circa	Tweed Frieze			
	Classic Boucle				
	Dune				
	Lagos				
	Noble				
	Palisade				
	Sahara				
	Journey				
	Keaton				
	Knoll Felt				
	Knoll Hopsack				
	Ludlow				
	Melody				
	Prairie				

Spinneybeck Leather





Check with your KnollTextiles or Spinneybeck Representative for changes or additions.



	description	w	d	h	seat finish	weight
<i>Designer(s):</i> Edward Barber and Jay Osgerby, 2014	BO10C stool, indoor fixed height, swivel seat 	14 1/4"	14 1/4"	18"	Aluminum, polished	14 lbs.
		14 1/4"	14 1/4"	18"	Ash	12 lbs.
	BO10CO stool, outdoor fixed height, swivel seat 	14 1/4"	14 1/4"	18"	Aluminum, painted (seat matches base)	14 lbs.
		14 1/4"	14 1/4"	18"	Teak	12 lbs.
	BO11C stool, indoor adjustable height, swivel seat 	14 1/4"	14 1/4"	18" - 22"	Aluminum, painted (seat matches base)	15 lbs.
		14 1/4"	14 1/4"	18" - 22"	Aluminum, polished	15 lbs.
		14 1/4"	14 1/4"	18" - 22"	Ash	13 lbs.
		14 1/4"	14 1/4"	18" - 22"	Teak	13 lbs.



pattern no.	list
BO10C-AP-()	\$723.
BO10C-AE-()	1,018.
BO10CO-()-()	616.
BO10CO-K-()	1,291.
BO11C-()-()	665.
BO11C-AP-()	772.
BO11C-AE-()	1,066.
BO11C-K-()	1,340.

Order Code	Ordering Information	Construction
<i>Example:</i> BO10C-AP-CRLT	<i>Aluminum seat finishes:</i> Polished Aluminum (suffix AP) Painted Aluminum Seat *: Jet Black (Suffix 111T) Med. Metallic Grey, (suffix 612T) Red Coral (suffix CRLT) Sterling (suffix 906T) White (suffix WHTT) (base must be specified in the same color)	<i>Base paint finishes:</i> Jet Black (suffix 111T) Medium Metallic Grey (suffix 612T) Red Coral (suffix CRLT) Sterling (suffix 906T) White (suffix WHTT) <i>Maintenance:</i> See pages 28-29.
BO10C	Stool, indoor fixed height, swivel seat	<i>Base:</i> Base is constructed of die-cast aluminum with stainless steel fasteners and finished with a highly durable powder coat paint. Height adjustable
AP	Aluminum, polished	<i>Aluminum Seats:</i> Contoured die-cast aluminum seats are attached to the base with stainless steel fasteners. Available in a polished aluminum or painted with a highly durable powder coat paint.
CRLT	Red Coral	<i>Wood Seats:</i> Contoured wood seats are available in ebonized ash or an oiled teak.
<i>Specify:</i> 1. Pattern number 2. Seat selection 3. Base selection	<i>Wood Seat Finishes:</i> Ebonized Ash (suffix AE) Teak, natural (suffix K) * * Outdoor Use: The painted aluminum and teak seats are approved for outdoor use when used on the fixed height stool only	

Harry Bertoia Side Chair

	description	seat h	w	d	h	textile fabric yds.	req. leather sq. ft.	weight
<i>Designer(s):</i> Harry Bertoia, 1952	420CU Side chair, full cover 	17 3/4"	21 3/4"	19 3/4"	28 3/4"	1.8	n/a	14 lbs.
		17 3/4"	21 3/4"	19 3/4"	28 3/4"	1.8	n/a	14 lbs.
<i>Award(s):</i> “Designer of the Year” 1955, USA; Certificate of Merit, American Institute of Architects	420F Full cover replacement 420C Side chair, back pad and seat cushion 					1.8	n/a	
		17 3/4"	21 3/4"	19 3/4"	28 3/4"	1.5	n/a	14 lbs.
	420P Back pad replacement 420KP Back pad and seat cushion replacement					0.7	n/a	
		17 3/4"	21 3/4"	19 3/4"	28 3/4"	0.8	14	14 lbs.
	420C Side chair, seat cushion or unupholstered 420K Seat cushion replacement	17 3/4"	21 3/4"	19 3/4"	28 3/4"	0.8	14	14 lbs.
		17 3/4"	21 3/4"	19 3/4"	28 3/4"	0.8	14	14 lbs.

Order Code	Ordering Information
<i>Example:</i> 420C-C-K-K242/13	
420C Side chair	<i>Frame finishes:</i> Black (suffix BL) Blue (suffix BU) Green (suffix GE)  Polished Chrome (suffix C) Red (suffix RD) Satin Chrome (suffix CO) White (suffix W) Yellow (suffix YL)
C Polished Chrome	
K Seat cushion	<i>Upholstery options:</i> Full cover (suffix U)  Seat cushion only (suffix K) Back pad and seat cushion combination (suffix KP)
K242/13 Vinyl, White	<i>Upholstery/COM information:</i> Prices shown include fabric or leather upholstery. Contact your Knoll representative for colors. Only approved KnollTextiles and Spinneybeck leathers may be ordered.
<i>Specify:</i>	<i>Customer's Own Material</i> is available pending approval. For approval requirements, processing instructions and ordering information please see page 18.
1. Pattern number	<i>Cal 133 Fire Code</i>  : The Bertoia Chairs with seat cushion attached comply with the California Technical Bulletin 133 standard in all upholstery. All textiles marked with a flame are also Cal 133 approved for full cover or seat and back pad upholstery. Specify suffix -C at end of pattern number and suffix -133 at end of textile selection.
2. Finish selection	<i>Note:</i> The Knoll logo is stamped into the base of the chair.
3. Upholstery option	The Bertoia Side Chair is Greenguard certified.
4. Cal 133 Fire Code option	
5. Textile selection	<i>Outdoor use:</i> With proper care and limited exposure to the elements, the Bertoia Collection is appropriate for outdoor environments. Specify powder coat finish (red, yellow, green, blue, black, white). Consult a Knoll representative for appropriate upholstery options.
<i>For cushion replacement specify:</i>	
1. Pattern number	
2. Textile selection	

pattern no.	unuph. (remove suffix -K)	grades A	COM B	C	D	E	F	G	H	I	COL U	V	W	X	Y
420C-()-U		\$1,665.	\$1,752.	\$1,831.	\$1,931.	\$2,003.	\$2,061.	\$2,149.	\$2,330.	\$2,461.					
420C-CO-U		1,943.	2,032.	2,111.	2,209.	2,283.	2,342.	2,428.	2,608.	2,739.					
420F-()		770.	854.	929.	1,020.	1,094.	1,145.	1,229.	1,404.	1,526.					
420C-()-KP		1,787.	1,831.	1,876.	1,923.	1,962.	1,993.	2,038.	2,131.	2,276.					
420C-CO-KP		2,077.	2,122.	2,165.	2,213.	2,253.	2,282.	2,330.	2,421.	2,566.					
420P-()		514.	534.	552.	574.	591.	603.	625.	667.	698.					
420KP-()		817.	859.	900.	947.	983.	1,011.	1,057.	1,143.	1,208.					
420C-()-K 	938.	1,177.	1,214.	1,253.	1,296.	1,330.	1,360.	1,400.	1,481.	1,544.	1,775.	1,920.	2,212.	2,272.	2,344.
420C-CO-K	1,226.	1,467.	1,505.	1,542.	1,586.	1,620.	1,650.	1,689.	1,772.	1,832.	2,065.	2,209.	2,502.	2,563.	2,634.
420K-() 	293.	328.	364.	405.	435.	460.	497.	573.	628.	842.	973.	1,239.	1,293.	1,352.	

Construction	Approved KnollTextiles Grades/Fabrics	Spinneybeck Leather
<i>Base and basket:</i> Welded steel with rods in polished or satin chrome, or highly durable outdoor power coat (red, yellow, green, blue, white, black). The diameter of the base rods are 11mm. The diameter of the edge rods is 4.5 mm and the interlacements measure 4mm. The chair features stainless steel connections and plastic glides.	A Bocce Common Ground * Commuter Cloth * Crossroad * Delite * Hourglass Mariner * Overture Presto * Soliloquy Sonnet * Trophy * Uni-Form *	U Vicenza Volo V Acqua Andes Embossed Tipped Hand Tipped Velluto Pelle W Alaska Amazon Antique Derby Forte Lucente Sabrina Umbria
<i>Upholstery:</i> Cushion and back pad secured to chair with domed metal lock snaps. Seat cushions and back pads have fabric edges. Full covers are stretched over wire seat basket and attach to seat basket with hooks. Back pad is not available with leather upholstery.	B continued Roam Rush Hour Summit * Sutton Synth * Tabloid Venue * Versa Vinyl Wide Angle Zipline C Axiom Classic Boucle * Dahlia CR Durand Earthwork Entourage * Hula Hoop Lagos Milestone Moto CR Noble Pullman * Quark Roundtrip Sinclair Smart Spectator Spot On Swing * Tight Rope Tower Grid Wit Ransom *	X Ducale Ducale Velour Y Cervo Copenhagen Distressed Gemma Lucca Marissa Portofino Riva Torello * Approved for fully upholstered versions. ‡ Approved for Cal 133 upholstery. <i>Check with your KnollTextiles or Spinneybeck Representative for changes or additions.</i>
	D Hologram Masquerade Menagerie Zoom E Aegean * Highland * Ikat Stripe Katazome Kimono Marquee Nature Walk Sherman * Tryst F Atelier * Calais Cotton Velvet Cornaro * Glider Icon Intrigue * In Stitches * Liberty Mod Plaid Totem Tweed Frieze	G Alter Ego * Haze * Kamani Melange * Modern Tweed * Petite Floral Serendipity Straie Stripe Ultrasuede * Utrillo * H Arno * Bavaria * Catwalk * Magritte * I Aswan Byron Cato * Cummings Dynamic Ita * Knoll Velvet * North Island * Rutledge Tudor Vermeer * Zimba *

Harry Bertoia

Two-Tone Side Chair

	description	seat h	w	d	h	textile fabric yds	req. leather sq. ft	weight
<i>Designer(s):</i> Harry Bertoia, 1952	420CT-U Two-Tone Side chair, full cover	17 3/4"	21 3/4"	19 3/4"	28 3/4"	1.8	n/a	14 lbs.
<i>Award(s):</i> "Designer of the Year" 1955, USA; Certificate of Merit, American Institute of Architects	420CT-KP Two-Tone Side chair, back pad and seat cushion	17 3/4"	21 3/4"	19 3/4"	28 3/4"	1.5	n/a	14 lbs.
	420CT-K Two-Tone Side chair, seat cushion	17 3/4"	21 3/4"	19 3/4"	28 3/4"	0.8	14	14 lbs.
	420F Full cover replacement					1.8	n/a	
	420KP Back pad and seat cushion replacement					1.5	n/a	
	420P Back pad replacement					0.7	n/a	
	420K Seat cushion replacement					0.8	14	



pattern no.	unuph.	A	B	C	D	E	F	G	H	I	COL U	V	W	X	Y	
420CT-U(-)(-)(-)		\$1,665.	\$1,752.	\$1,831.	\$1,931.	\$2,003.	\$2,061.	\$2,149.	\$2,330.	\$2,461.						
420CT-KP(-)(-)(-)		1,787.	1,831.	1,876.	1,923.	1,962.	1,993.	2,038.	2,131.	2,276.						
420CT-K(-)(-)(-)		938.	1,177.	1,214.	1,253.	1,296.	1,330.	1,360.	1,400.	1,481.	1,544.	1,775.	1,920.	2,212.	2,272.	2,344.
420F(-)		770.	854.	929.	1,020.	1,094.	1,145.	1,229.	1,404.	1,526.						
420KP(-)		817.	859.	900.	947.	983.	1,011.	1,057.	1,143.	1,208.						
420P(-)		514.	534.	552.	574.	591.	603.	625.	667.	698.						
420K(-)		293.	328.	364.	405.	435.	460.	497.	573.	628.	842.	973.	1,239.	1,293.	1,352.	

Order Code	Ordering Information
<i>Example:</i> 420CT-U-BU-W-K242/13	
420CT-U Two-Tone Side chair, fully upholstered	<i>Frame finishes:</i> Polished Chrome (suffix C) Black (suffix BL) Blue (suffix BU) Red (suffix RD) White (suffix W)
BU Blue basket	<i>Upholstery options:</i> Full cover (suffix U) ☒ Seat cushion only (suffix K) Back pad and seat cushion combination (suffix KP)
W White base	<i>Upholstery/COM information:</i> Prices shown include fabric or leather upholstery. Contact your Knoll representative for colors. Only approved KnollTextiles and Spinneybeck leathers may be ordered.
K242/13 Vinyl, White	<i>Customer's Own Material</i> is available pending approval. For approval requirements, processing instructions and ordering information please see page 18. ☒ <i>KnollStudio 20 Day Program:</i> Replacement seat cushions are available with in-stock KnollTextiles. For specific information, consult pages 30 - 33. <i>Note:</i> The Knoll logo is stamped into the base of the chair. The Bertoia Side Chair is Greenguard certified. <i>Maintenance:</i> See pages 28-29.
<i>Specify:</i>	
1. Pattern number	
2. Basket finish selection	
3. Base finish selection	
4. Textile selection	
<i>For cushion replacement specify:</i>	
1. Pattern number	
2. Textile selection	

Construction	Approved KnollTextiles Grades/Fabrics	Spinneybeck Leather
<i>Base and basket:</i> Welded steel with rods in polished chrome, or highly durable power coat (red, blue, white, black). The diameter of the base rods are 11mm. The diameter of the edge rods is 4.5 mm and the interlacements measure 4mm. The chair features stainless steel connections and plastic glides. <i>Upholstery:</i> Cushion and back pad secured to chair with domed metal lock snaps. Seat cushions and back pads have fabric edges. Full covers are stretched over wire seat basket and attach to seat basket with hooks. Back pad is not available with leather upholstery. <i>Note:</i> Two-Tone Bertoia Chairs are not appropriate for outdoor use. Screws that attach the base to the basket are not painted to match the basket finish.	A Bocce Common Ground * Commuter Cloth * Crossroad * Delite * Hourglass Mariner * Overture Presto * Soliloquy Sonnet * Trophy * Uni-Form * B Abacus Belize Bistro Calypso * Cameo Chronicle Diva * Ferry * Forza Grande Grandview Holbrook Journey * Keaton * Knoll Felt *▲ Knoll Hopsack *▲ Little Devil * Petal Pusher * Prairie Prim ▲ Ransom * C Axiom Classic Boucle *▲ Dahlia CR Durand Earthwork Entourage * Hula Hoop Lagos Milestone Moto CR Noble Pullman * Quark Roundtrip Sinclair Smart Spectator Spot On Swing * Tight Rope Tower Grid Wit D continued Roam Rush Hour Summit * Sutton Synth * Tabloid Venue * Versa Vinyl Wide Angle Zipline E Aegean * Highland * Ikat Stripe Katazome Kimono Marquee Nature Walk Sherman * Tryst F Atelier * Calais Cotton Velvet Cornaro * Glider Icon Intrigue * In Stitches * Liberty Mod Plaid Totem Tweed Frieze G Alter Ego * Haze * Kamani Melange * Modern Tweed * Petite Floral Serendipity Straie Stripe Ultrasuede * Utrillo *▲ H Arno *▲ Bavaria * Catwalk * Magritte * I Aswan Byron Cato * Cummings Dynamic Ita * Knoll Velvet * North Island *▲ Rutledge Tudor Vermeer * Zimba	U Vicenza Volo V Acqua Andes Embossed Tipped Hand Tipped Velluto Pelle W Alaska Amazon Antique Derby Forte Lucente Sabrina Umbria * Approved for fully upholstered versions. ▲ Approved for Cal 133 upholstery. <i>Check with your KnollTextiles or Spinneybeck Representative for changes or additions.</i>
	X Ducale Ducale Velour Y Cervo Copenhagen Distressed Gemma Lucca Marissa Portofino Riva Torello	

Harry Bertoia

Barstools

Bar Height Stools

Designer(s):
Harry Bertoia, 1952

Award(s):
“Designer of the Year” 1955,
USA; Certificate of Merit,
American Institute of Architects



description	seat h	w	d	h	textile fabric yds.	req. leather sq. ft.	weight
428CU Barstool, full cover, bar height	29 1/4"	21 3/4"	22"	41 1/4"	1.8	n/a	22 lbs.
	29 1/4"	21 3/4"	22"	41 1/4"	1.8	n/a	22 lbs.
428F Full cover replacement for 428C					1.8	n/a	
428C-KP Barstool, back pad and seat cushion, bar height	29 1/4"	21 3/4"	22"	41 1/4"	1.5	n/a	22 lbs.
	29 1/4"	21 3/4"	22"	41 1/4"	1.5	n/a	22 lbs.
428P Back pad replacement					0.7	n/a	
428KP Back pad and seat cushion replacement					1.5	n/a	
428C Barstool, seat cushion or unupholstered, bar height	29 1/4"	21 3/4"	22"	41 1/4"	0.8	14	21 lbs.
	29 1/4"	21 3/4"	22"	41 1/4"	0.8	14	21 lbs.
428K Seat cushion replacement for 428C					0.8	14	

Order Code Ordering Information

<i>Example:</i> 428C-C-KP-K1021/8
428C Barstool, bar height
C Polished Chrome
KP Back and seat pad
K1021/8 Ultrasuede, Poppy

Frame finishes:
Black (suffix BL)
☞ Polished Chrome (suffix C)
Satin Chrome (suffix CO)
White (suffix W)

Customer's Own Material is available pending approval. For approval requirements, processing instructions and ordering information, please see page 18.

Cal 133 Fire Code ♣ :
The Bertoia Barstools with seat cushion attached comply with the California Technical Bulletin 133 standard in all upholstery. **All textiles marked with a flame are also Cal 133 approved for full cover or seat and back pad upholstery.** Specify suffix -C at end of pattern number and suffix -133 at end of textile selection.

- Specify:*
1. Pattern number
 2. Finish selection
 3. Upholstery option
 4. Cal 133 Fire Code option
 5. Textile selection

Upholstery options:
Full cover (suffix U)
☞ Seat cushion only (suffix K)
Back pad and seat cushion combination (suffix KP)

☞ *KnollStudio 20-Day Program:*
The Bertoia 428 barstool is available in a polished chrome finish on the 20-Day Program unupholstered or with seat cushion upholstered with any in-stock KnollTextile. Seat cushion only is available on the 20-day program with any in-stock KnollTextile. For specific information, consult pages 30-33.

Maintenance:
See pages 28-29.

Note:
The Knoll logo is stamped into the base of the barstool.

- For cushion replacement, specify:*
1. Pattern number
 2. Textile selection

Upholstery/COM information:
Prices shown include fabric or leather upholstery. Contact your Knoll representative for colors. Only approved KnollTextiles and Spinneybeck leather may be ordered.

Outdoor use:
With proper care and limited exposure to the elements, the 428 Bertoia Barstool is appropriate for outdoor environments. Specify outdoor powder coat. Consult a Knoll representative for appropriate upholstery options.

The Bertoia Bar Height stool is Greenguard certified.

pattern no.	unuph. (remove suffix -K)	grades A	COM B	C	D	E	F	G	H	I	COL U	V	W	X	Y
428C-()-U		\$2,258.	\$2,334.	\$2,406.	\$2,488.	\$2,552.	\$2,603.	\$2,681.	\$2,832.	\$2,947.					
428C-CO-U		2,735.	2,811.	2,884.	2,964.	3,032.	3,079.	3,157.	3,311.	3,423.					

428F-()	740.	821.	893.	981.	1,052.	1,101.	1,182.	1,350.	1,467.						
428C-()-KP	2,516.	2,563.	2,605.	2,652.	2,692.	2,721.	2,768.	2,859.	2,927.						
428C-CO-KP	3,014.	3,060.	3,102.	3,151.	3,190.	3,217.	3,266.	3,358.	3,423.						

428P-()	494.	513.	531.	552.	568.	580.	601.	641.	671.						
428KP-()	786.	826.	865.	911.	945.	972.	1,016.	1,099.	1,162.						

428C-()-K ☞	1,666.	1,869.	1,904.	1,938.	1,976.	2,006.	2,029.	2,062.	2,137.	2,189.	2,391.	2,513.	2,765.	2,817.	2,878.
428C-CO-K	2,163.	2,366.	2,401.	2,434.	2,473.	2,504.	2,526.	2,562.	2,635.	2,686.	2,888.	3,010.	3,262.	3,317.	3,376.

428K-() ☞	282.	315.	350.	389.	418.	442.	478.	551.	604.	810.	936.	1,191.	1,243.	1,300.	
-------------------	------	------	------	------	------	------	------	------	------	------	------	--------	--------	--------	--

Construction Approved KnollTextiles Grades/Fabrics Spinneybeck Leather

Base and basket:
Welded steel with rods in polished or satin chrome or highly durable bonded powder coat (white and black). Stainless steel connections. Holes pre-drilled for easy snap-in installation. 1 1/4" wide round articulated glides on barstool. Black plastic glide with metal cover. Barstool base wire diameter measures 14mm, basket edge measures 7mm and interlacements measure 5 mm.

Upholstery:
Cushion and back pad secured to chair with domed metal lock snaps. Seat cushions and back pads have fabric edges. Full covers are stretched over wire seat basket and attach to seat basket with hooks. Back pad is not available with leather upholstery.

- A** Bocce
- Common Ground *
- Commuter Cloth *
- Crossroad *
- Delite *
- Hourglass *
- Mariner *
- Overture
- Presto *
- Soliloquy
- Sonnet *
- Stacks
- Trophy *
- Uni-Form *
- B** Abacus
- Belize
- Bistro
- Calypso *
- Cameo
- Chronicle
- Diva *
- Ferry *
- Forza
- Grande
- Grandview
- Holbrook
- Journey *
- Keaton *
- Knoll Felt *♣
- Knoll Hopsack *♣
- Little Devil *
- Night Life
- Petal Pusher *
- Prairie
- Prim ♣
- Ransom *
- Ricochet
- C** continued
- Roam
- Rush Hour
- Soiree
- Summit *
- Sutton
- Synth *
- Tabloid
- Venue *
- Versa
- Vinyl
- Wide Angle
- Zipline
- D** Hologram
- Masquerade
- Menagerie
- Theory
- Zoom
- E** Aegean *
- Highland *
- Ikat Stripe
- Katazome
- Kimono
- Marquee
- Nature Walk
- Sherman *
- Tryst
- F** Atelier *
- Calais CottonVelvet
- Cornaro *
- Clider
- Groove Line
- Icon
- Intrigue *
- In Stitches *
- Liberty
- Mod Plaid
- Totem
- Tweed Frieze
- G** Alter Ego *
- Arabella
- Haze *
- Kamani
- Kingston
- Melange *
- Modern Tweed *
- Petite Floral
- Sablon *
- Serendipity
- Straie Stripe
- Ultrasuede *
- Utrillo *♣
- H** Arno *♣
- Bavaria *
- Catwalk *
- Gezelle *
- Magritte *
- I** Aswan
- Byron
- Cato *
- Cummings
- Dynamic
- Fiori *
- Ita *
- Knoll Velvet *
- North Island *♣
- Rutledge
- Tudor
- Vermeer *
- Zimba

- U** Vicenza
- Volo
- V** Acqua
- Andes
- Embossed Tipped
- Hand Tipped
- Velluto Pelle
- W** Alaska
- Amazon
- Antique
- Derby
- Forte
- X** Ducale
- Ducale Velour
- Y** Cervo
- Copenhagen
- Distressed
- Gemma
- Lucca
- Marissa
- Portofino
- Riva
- Torello

* Approved for fully upholstered versions.
♣ Available for Cal 133 upholstery.

Check with your KnollTextiles or Spinneybeck Representative for changes or additions.

Harry Bertoia

Barstools

Counter Height Stools

Designer(s):
Harry Bertoia, 1952

Award(s):
“Designer of the Year” 1955, USA; Certificate of Merit, American Institute of Architects



description	seat h	w	d	h	textile fabric yds.	req. leather sq. ft.	weight
427CU Barstool, full cover, counter height	27 1/2"	21 3/4"	22"	39 1/2"	1.8	n/a	20 lbs.
	27 1/2"	21 3/4"	22"	39 1/2"	1.8	n/a	20 lbs.
427F Full cover replacement for 427C					1.8	n/a	
427C-KP Barstool, back pad and seat cushion, counter height	27 1/2"	21 3/4"	22"	39 1/2"	1.5	n/a	20 lbs.
	27 1/2"	21 3/4"	22"	39 1/2"	1.5	n/a	20 lbs.
427P Back pad replacement					0.7	n/a	
427KP Back pad and seat cushion replacement					1.5	n/a	
427C Barstool, seat cushion or unupholstered, counter height	27 1/2"	21 3/4"	22"	39 1/2"	0.8	14	20 lbs.
	27 1/2"	21 3/4"	22"	39 1/2"	0.8	14	20 lbs.
427K Seat cushion replacement for 427C					0.8	14	





Order Code	Ordering Information
<i>Example:</i> 427C-U-K1207/2	<i>Frame finishes:</i>
427C Barstool, counter height	Black (suffix BL)
C Polished Chrome	Polished Chrome (suffix C)
U Fully upholstered	Satin Chrome (suffix CO)
K1207/2 Knoll Felt, Tan	White (suffix W)
	<i>Upholstery options:</i>
	Full cover (suffix U)
	Seat cushion only (suffix K)
	Back pad and seat cushion combination (suffix KP)
	<i>Upholstery/COM information:</i>
	Prices shown include fabric or leather upholstery. Contact your Knoll representative for colors. Only approved KnollTextiles and Spinneybeck leathers may be ordered.
	<i>Outdoor use:</i>
	With proper care and limited exposure to the elements, the 427 Bertoia Barstool is appropriate for outdoor environments. Specify outdoor powder coat. Consult a Knoll representative for appropriate upholstery options.
	<i>Customer's Own Material is available pending approval for approval requirements, processing instructions and ordering information please see page 18.</i>
	<i>Cal 133 Fire Code *</i> : The Bertoia Barstools with seat cushion attached comply with the California Technical Bulletin 133 standard in all upholstery. All textiles marked with a flame are also Cal 133 approved for full cover or seat and back pad upholstery. Specify suffix -C at end of pattern number and suffix -133 at end of textile selection.
	<i>Maintenance:</i> See pages 28-29.
	<i>Note:</i> The Knoll logo is stamped into the base of the barstool.
	The Bertoia Counter Height stool is Greenguard certified
	<i>KnollStudio 20-Day Program:</i> The Bertoia 427 barstool is available in a polished chrome finish unupholstered or with a seat pad on the 20-day program. Replacement seat cushion is also available. Seat cushion must be upholstered with an in-stock KnollTextile. For specific information, consult pages 30-33.

pattern no.	unuph. (remove suffix -K)	grades A	COM B	C	D	E	F	G	H	I	COL U	V	W	X	Y
427C-()-U		\$2,258.	\$2,334.	\$2,406.	\$2,488.	\$2,552.	\$2,603.	\$2,681.	\$2,832.	\$2,947.					
427C-CO-U		2,735.	2,811.	2,884.	2,964.	3,032.	3,079.	3,157.	3,311.	3,423.					
427F-()		740.	821.	893.	981.	1,052.	1,101.	1,182.	1,350.	1,467.					
427C-()-KP		2,516.	2,563.	2,605.	2,652.	2,692.	2,721.	2,768.	2,859.	2,927.					
427C-CO-KP		3,014.	3,060.	3,102.	3,151.	3,190.	3,217.	3,266.	3,358.	3,423.					
427P-()		494.	513.	531.	552.	568.	580.	601.	641.	671.					
427KP-()		786.	826.	865.	911.	945.	972.	1,016.	1,099.	1,162.					
427C-()-K	1,666.	1,869.	1,904.	1,938.	1,976.	2,006.	2,029.	2,062.	2,137.	2,189.	2,391.	2,513.	2,765.	2,817.	2,878.
427C-CO-K	2,163.	2,366.	2,401.	2,434.	2,473.	2,504.	2,526.	2,562.	2,635.	2,686.	2,888.	3,010.	3,262.	3,317.	3,376.
427K-()	282.	315.	350.	389.	418.	442.	478.	551.	604.	810.	936.	1,191.	1,243.	1,300.	

Construction	Approved KnollTextiles Grades/Fabrics	Spinneybeck Leather
<i>Base and basket:</i> Welded steel with rods in polished or satin chrome or highly durable bonded powder coat (white and black). Stainless steel connections. Holes pre-drilled for easy snap-in installation. 1 1/4" wide round articulated glides on barstool. Black plastic glide with metal cover. Barstool base wire diameter measures 14mm, basket edge measures 7mm and interlacements measure 5 mm.	A Bocce Common Ground * Commuter Cloth * Crossroad * Delite * Hourglass Mariner * Overture Presto * Soliloquy Sonnet * Stacks Trophy * Uni-Form * B Abacus Belize Bistro Calypso * Cameo Chronicle Diva * Ferry * Forza Grande Grandview Holbrook Journey * Keaton * Knoll Felt * Knoll Hopsack * Little Devil * Night Life Petal Pusher * Prairie Prim Ransom * Ricochet C Axiom Biota Classic Boucle * Dahlia CR Durand Earthwork Entourage * Hula Hoop Lagos Milestone Moto CR Noble Pullman * Quark Roundtrip Sinclair Smart Spectator Spot On Swing * Tight Rope * Tower Grid * Vibe Wit D continued Roam Rush Hour Soiree Summit * Sutton Synth * Tabloid Venue Versa Vinyl Wide Angle Zipline E Aegean * Highland * Ikat Stripe Katazome Kimono Marquee Nature Walk Sherman * Tryst F Atelier * Calais Cotton Velvet Cornaro * Glider Icon Intrigue * In Stitches * Liberty Mod Plaid Totem Tweed Frieze G Hologram Masquerade Menagerie Theory Zoom H Arno * Bavaria * Catwalk * Gezelle * Magritte * I Aswan Byron Cato * Cummings Dynamic Fiori * Ita * Knoll Velvet * North Island * Rutledge Tudor Vermeer * Zimba U Vicenza Volo V Acqua Andes Embossed Tipped Hand Tipped Velluto Pelle W Alaska Amazon Antique Derby Forte X Ducale Ducale Velour Y Cervo Copenhagen Distressed Gemma Lucca Marissa Portofino Riva Torello * Approved for fully upholstered versions. Available for Cal 133 upholstery. Check with your KnollTextiles or Spinneybeck Representative for changes or additions.	

Harry Bertoia

Bertoia Molded Shell Side Chair and Barstool

	description	seat h	w	d	h	weight	base finish
<i>Designer(s):</i> Harry Bertoia, 1960	420N Molded Shell Side chair 	17 3/4"	21 3/4"	19 3/4"	28 3/4"	14 lbs.	Painted
		17 3/4"	21 3/4"	19 3/4"	28 3/4"	14 lbs.	Polished chrome
	427N Molded Shell Barstool, counter height 	27 1/4"	21 3/4"	22"	41"	22 lbs.	Painted
		27 1/4"	21 3/4"	22"	41"	22 lbs.	Polished Chrome
	428N Molded Shell Barstool, bar height 	29 1/4"	21 3/4"	22"	43"	23 lbs.	Painted
		29 1/4"	21 3/4"	22"	43"	23 lbs.	Polished chrome

pattern no.	
420N-()-()	\$520.
420N-()-C	540.
427N-()-()	860.
427N-()-C	880.
428N-()-()	860.
428N-()-C	880.

Order Code	Ordering Information	Construction
<i>Example:</i> 420N-WH-C	<i>Molded Shell finishes:</i>	<i>Base:</i>
420N Molded Shell side chair	White (suffix WH)	Welded steel rods in polished chrome or highly durable bonded powder coat (white and black).
WH White shell	Medium Grey (suffix MG)	Side Chairs: diameter of the base rods are 11mm featuring stainless steel connections and plastic glides.
C Polished chrome base	Blue (suffix BU)	Bar and Counter Height Stools: diameter of the base rods are 14mm featuring stainless steel connections and 1 1/4" wide round articulated glides with metal cover.
	Orange Red (suffix OR)	
	Yellow (suffix YE)	
<i>Specify:</i>	<i>Base finishes:</i>	<i>Basket:</i>
1. Pattern number	Polished Chrome (suffix C)	Glass fiber reinforced nylon shell
2. Molded Shell finish	Black (suffix BL)	
3. Base finish	White (suffix W)	
		<i>Note: Bertoia Molded Shell Chairs and Stools are not appropriate for outdoor use.</i>

Harry Bertoia

Diamond Lounge Seating

Designer(s):
Harry Bertoia, 1952

Award(s):
“Designer of the Year” 1955, USA; Certificate of Merit, American Institute of Architects



description	seat h	w	d	h	textile fabric yds.	req. leather sq. ft.	weight
421L Diamond chair, seat cushion with glides	16 1/2"	33 1/2"	28 1/4"	30"	0.7	14	16 lbs.
	16 1/2"	33 1/2"	28 1/4"	30"	0.7	14	16 lbs.
	16 1/2"	33 1/2"	28 1/4"	30"	0.7	14	16 lbs.
421K Seat cushion replacement					0.7	14	
421LU Diamond chair, full cover with glides	16 1/2"	33 1/2"	28 1/4"	30"	3.0	n/a	16 lbs.
	16 1/2"	33 1/2"	28 1/4"	30"	3.0	n/a	16 lbs.
421F Full cover replacement					3.0	n/a	
421LS Child's Diamond chair, seat cushion with glides	11 1/4"	24 1/2"	22 3/4"	24"	0.7	11	9 lbs.
	11 1/4"	24 1/2"	22 3/4"	24"	0.7	11	9 lbs.
421KS Child's Diamond, seat cushion replacement					0.7	11	
421LS Child's Diamond chair, full cover with glides	11 1/4"	24 1/2"	22 3/4"	24"	2.5	n/a	10 lbs.
	11 1/4"	24 1/2"	22 3/4"	24"	2.5	n/a	10 lbs.
421FS Child's Diamond, full cover replacement					2.5	n/a	
422LU Large diamond chair, full cover with glides	15 1/4"	45"	31 1/2"	28 3/4"	3.8	n/a	24 lbs.
	15 1/4"	45"	31 1/2"	28 3/4"	3.8	n/a	24 lbs.
422F Full cover replacement					3.8	n/a	

Order Code	Ordering Information
Example: 421L-CO-U-K231/1	
421L Diamond chair	Frame finishes (421L,LU): Black (suffix BL)
CO Satin Chrome	☞ Polished Chrome (suffix C) Satin Chrome (suffix CO) White (suffix W) 18k Gold Plated (suffix GLD)
U Fully upholstered	Frame finishes (421LS): Black (suffix BL) ☞ Polished Chrome (suffix C) Satin Chrome (suffix CO) White (suffix W) 18k Gold Plated (suffix GLD)
K231/1 Cuddle Cloth, Neutral	Frame finishes (422LU): Black (suffix 1) Polished Chrome (suffix C) White (suffix W)

Specify:
1. Pattern number
2. Finish selection
3. Upholstery option
4. Cal 133 Fire Code Option
5. Textile selection

For cushion replacement, specify:
1. Pattern number
2. Textile selection

Upholstery options:
Full cover (suffix U)
Seat cushion only (suffix K)

Upholstery/COM information:
Prices shown include fabric or leather upholstery. Contact your Knoll representative for colors. Only approved KnollTextiles and Spinneybeck leathers may be ordered.

Customer's Own Material is available pending approval. For approval requirements, processing instructions and ordering information please see page 18. ☞ **KnollStudio 20-Day Program:** The Diamond chair in a polished chrome finish is available on the KnollStudio 20-Day program with seat cushion upholstered with any in-stock KnollTextile. For specific information, consult pages 31 -33.

Outdoor use:
With proper care and limited exposure to the elements, the 421 Bertoia Diamond Chair is appropriate for outdoor environments. Specify powder coat finish. Consult a Knoll representative for appropriate upholstery options.

Cal 133 Fire Code☜:
Bertoia 421 chair with seat pad attached complies with the California Technical Bulletin 133 standard in *all* upholstery. Cal 133 is approved for selected fabrics marked with a flame for fully upholstered versions. Specify suffix -C at end of pattern number. **Maintenance:** See pages 28-29.

Note:
The Knoll logo is stamped into the base of the chair.

The Bertoia Diamond Lounge Seating is Greenguard certified.

The Child's Diamond Chair is compliant to the Consumer Product Safety Improvement Act of 2008 for Children's Products, 16 C.F.R. 1303, CPSIA Title 1 Section 101 for Total Lead in Substrates and Surface Coatings.



pattern no.	grades	COM	C	D	E	F	G	H	I	COL	V	W	X	Y
	A	B								U				
421L(-)-K ☞	\$1,851.	\$1,892.	\$1,932.	\$1,970.	\$2,003.	\$2,028.	\$2,070.	\$2,148.	\$2,203.	\$2,609.	\$2,763.	\$3,082.	\$3,149.	\$3,226.
421L-GLD-K ☞	3,203.	3,219.	3,238.	3,258.	3,287.	3,306.	3,335.	3,355.	3,415.	4,754.	4,817.	4,944.	4,970.	5,001.
421LCO-K	2,250.	2,290.	2,331.	2,368.	2,402.	2,427.	2,470.	2,546.	2,601.	3,009.	3,165.	3,483.	3,547.	3,626.
421K(-)	468.	504.	538.	574.	604.	628.	661.	733.	785.	1,149.	1,293.	1,577.	1,635.	1,705.
421L(-)-U	2,922.	3,091.	3,241.	3,407.	3,543.	3,643.	3,811.	4,133.	4,368.					
421LCO-U	3,305.	3,473.	3,621.	3,789.	3,927.	4,025.	4,191.	4,515.	4,750.					
421F(-)	1,143.	1,290.	1,424.	1,575.	1,695.	1,783.	1,936.	2,218.	2,325.					
421LS-C-K	1,081.	1,097.	1,112.	1,129.	1,143.	1,151.	1,173.	1,205.	1,236.	1,333.	1,400.	1,533.	1,561.	1,593.
421KS(-)	278.	296.	317.	335.	354.	365.	387.	422.	452.	578.	654.	813.	847.	884.
421LS-C-U	1,404.	1,462.	1,518.	1,580.	1,631.	1,668.	1,731.	1,849.	1,934.					
421FS(-)	705.	773.	841.	914.	972.	1,016.	1,090.	1,227.	1,329.					
422L(-C,1,2)-U	3,903.	4,080.	4,238.	4,420.	4,562.	4,671.	4,852.	5,192.	5,442.					
422F(-)	1,185.	1,335.	1,477.	1,633.	1,759.	1,851.	2,006.	2,305.	2,523.					

Construction	Approved KnollTextiles Grades/Fabrics	Spinneybeck Leather
Frame: Welded steel with rods in polished or satin (421L only) chrome finish, powder coat (white and black), or plated in 18k gold. Stainless steel connections. Four plastic glides. On all Diamond chairs, the base wire diameter measures 11mm. The frame edge wire diameter measures 4.5mm, the interlacements measure 4mm in diameter.	A Common Ground ☜ Crossroad Delite Hourglass Mariner Presto Sonnet Trophy Uni-Form	U Vicenza * Volo * V Acqua * Andes * Embossed Tipped * Hand Tipped * Velluto Pelle * W Alaska * Amazon * Antique * Derby * Forte *
Upholstery: Cushion secured to chair with lock-snaps. Full covers are stretched over wire frame and attach to seat basket with hooks. Cushions and covers fit all Bertoia Diamond Chairs manufactured since 1952 within a limited range of tolerance.	B continued Knoll Felt Knoll Hopsack Little Devil Prairie * Ransom * Synth Venue Vinyl *	W continued Lucente * Sabrina * Umbria * ☜ Ducale * Ducale Velour * Y Cervo * Copenhagen * Distressed * Gemma * Lucca * Marissa * Portofino * Riva * Saddle * Torello *
422L is not available with seat pad option.	C Classic Boucle ☜ Entourage Hula Hoop * Moto CR * Pullman Quark * Swing	I Cato Dynamic Ita Knoll Velvet North Island Vermeer Zimba
Child's Diamond Chair: The Child's Diamond Chair is 75% scale of the standard size and is only available with polished chrome frame.	D Hologram * Masquerade * Zoom *	* Available on 421K and 421KS seat cushion only. ☜ Available for Cal 133 upholstery.
	E Aegean Highland Marquee * Sherman	
	F Atelier Calais Cotton Velvet * Cornaro Icon * Intrigue In Stitches Totem * Tweed Frieze *	
	G continued Melange Modern Tweed Ultrasuede ☜ Utrillo *	
	H Arno Bavaria Catwalk * Magritte Stretch Appeal	
	G Alter Ego Haze	

Check with your KnollTextiles or Spinneybeck Representative for changes or additions.

Harry Bertoia

Two-Tone Diamond Chair

	description	seat h	w	d	h	textile fabric yds.	req. leather sq. ft.	weight
<i>Designer(s):</i> Harry Bertoia, 1952	421LT-U Two-Tone Diamond chair, full cover with glides	16 1/2"	33 1/2"	28 3/4"	30"	3.0	n/a	16 lbs.
<i>Award(s):</i> "Designer of the Year" 1955, USA; Certificate of Merit, American Institute of Architects								
	421LT-K Two-Tone Diamond chair, seat cushion with glides	16 1/2"	33 1/2"	28 3/4"	30"	0.7	14	16 lbs.
								
	421F Full cover replacement					3.0	n/a	
	421K Seat cushion replacement					0.7	14	

pattern no.	grades A	COM B	C	D	E	F	G	H	I	COL U	V	W	X	Y
421LT-U-(-)-(-)	\$2,922.	\$3,091.	\$3,241.	\$3,407.	\$3,543.	\$3,643.	\$3,811.	\$4,133.	\$4,368.					
421LT-K-(-)-(-)	1,851.	1,892.	1,932.	1,970.	2,003.	2,028.	2,070.	2,148.	2,203.	2,609.	2,763.	3,082.	3,149.	3,226.
421F-(-)	1,143.	1,290.	1,424.	1,575.	1,695.	1,783.	1,936.	2,218.	2,325.					
421K-(-)	468.	504.	538.	574.	604.	628.	661.	733.	785.	1,149.	1,293.	1,577.	1,635.	1,705.



Order Code	Ordering Information
<i>Example:</i> 421LT-K-RD-BL-H800/19	<i>Frame finishes:</i> Polished Chrome (suffix C) Black (suffix BL) Blue (suffix BU) Red (suffix RD) White (suffix W)
421LT-K Two-Tone Diamond chair, seat pad	<i>Cal 133 Fire Code</i> † : Bertoia 421 chair with seat pad attached complies with the California Technical Bulletin 133 standard in <i>all</i> upholstery. Cal 133 is approved for selected fabrics marked with a flame for fully upholstered versions. Specify suffix -C at end of pattern number.
RD Red basket	<i>Maintenance:</i> See pages 28-29.
BL Black base	<i>Note:</i> The Knoll logo is stamped into the base of the chair.
H800/19 Cato, Fire Red	The Bertoia Diamond Lounge Seating is Greenguard certified.
<i>Specify:</i> 1. Pattern number 2. Basket finish selection 3. Base finish selection 4. Textile selection	The Child's Diamond Chair is compliant to the Consumer Product Safety Improvement Act of 2008 for Children's Products, 16 C.F.R. 1303, CPSIA Title 1 Section 101 for Total Lead in Substrates and Surface Coatings.
<i>For cushion replacement, specify:</i> 1. Pattern number 2. Textile selection	<i>Upholstery options:</i> Full cover (suffix U) Seat cushion only (suffix K)
	<i>Upholstery/COM information:</i> Prices shown include fabric or leather upholstery. Contact your Knoll representative for colors. Only approved KnollTextiles and Spinneybeck leathers may be ordered.
	Customer's Own Material is available pending approval. For approval requirements, processing instructions and ordering information please see page 18.

Construction	Approved KnollTextiles Grades/Fabrics	Spinneybeck Leather
<i>Frame:</i> Welded steel with rods in polished chrome finish and powder coat. Stainless steel connections. Four plastic glides. On all Diamond chairs, the base wire diameter measures 11mm. The frame edge wire diameter measures 4.5mm, the interlacements measure 4mm in diameter.	A Common Ground † Crossroad Delite Hourglass Mariner Presto Sonnet Trophy Uni-Form	U Vicenza * Volo * V Acqua * Andes * Embossed Tipped * Hand Tipped * Velluto Pelle * W Alaska * Amazon * Antique * Derby * Forte * Lucente * Sabrina * Umbria *
<i>Upholstery:</i> Cushion secured to chair with lock-snaps. Full covers are stretched over wire frame and attach to seat basket with hooks. Cushions and covers fit all Bertoia Diamond Chairs manufactured since 1952 within a limited range of tolerance.	B continued Ransom * Synth Venue Vinyl * C Classic Boucle † Entourage Hula Hoop * Moto CR * Pullman Quark * Swing	X Ducale * Ducale Velour * Y Cervo * Copenhagen * Distressed * Lucca * Marissa * Gemma * Portofino * Riva * Saddle * Torello *
<i>Note:</i> Two-Tone Bertoia Diamond Chairs are not appropriate for outdoor use.	D Hologram * Masquerade * Zoom * E Aegean Highland Marquee * Sherman F Atelier Calais Cotton Velvet * Cornaro Icon * Intrigue In Stitches Totem * Tweed Frieze *	G Haze Melange Modern Tweed Ultrasuede † Utrillo * H Arno Bavaria Catwalk * Magritte Stretch Appeal I Cato Dynamic Ita Knoll Velvet North Island Vermeer Zimba
Screws that attach the base to the basket are not painted to match the basket finish.		* Available on 421K seat cushion only. † Available for Cal 133 upholstery.

Check with your KnollTextiles or Spinneybeck Representative for changes or additions.

Harry Bertoia

Bird Lounge Chair and Ottoman

	description	seat h	w	d	h	textile fabric yds.	req. leather sq. ft.	weight
<i>Designer(s):</i> Harry Bertoia, 1952	423LU Bird high back chair, full cover with glides	14 1/2"	38 1/2"	33"	40 1/4"	3.8	n/a	21 lbs.
<i>Award(s):</i> "Designer of the Year," USA, 1955; Certificate of Merit, American Institute of Architects; Design Center Stuttgart Award, W. Germany, 1962								
	423F Full cover replacement					3.8	n/a	
	424YU Ottoman, full cover with glides	14 1/2"	23 1/2"	17 1/4"	14 1/2"	1.3	n/a	9 lbs.
								
	424F Full cover replacement					1.3	n/a	



pattern no.	grades A	COM B	C	D	E	F	G	H	I
423L-(C,1,2)-U	\$4,671.	\$4,856.	\$5,030.	\$5,224.	\$5,379.	\$5,492.	\$5,685.	\$6,055.	\$6,322.
423F-()	1,447.	1,614.	1,775.	1,950.	2,091.	2,196.	2,366.	2,708.	2,949.
424Y-(C,1,2)-U	1,523.	1,583.	1,638.	1,707.	1,760.	1,801.	1,861.	1,991.	2,081.
424F-()	609.	667.	718.	774.	826.	862.	918.	1,036.	1,119.

Order Code	Ordering Information	Construction
<i>Example:</i> 423L-C-U-K1084/9	<i>Frame finishes:</i> Black (suffix 1) Polished Chrome (suffix C) White (suffix 2)	<i>Frame:</i> Welded steel with rods in polished chrome or bonded rilsan, a very durable and adhesive fused nylon-dipped finish. Scratch, chip, and chemical resistant. Stainless steel connections. Four plastic glides. Frame wire diameter measures 4.5mm. Interlacement wire diameter measures 4mm.
423L Bird high back chair	<i>Upholstery/COM information:</i> Prices shown include fabric or leather upholstery. Contact your Knoll representative for colors. Only approved KnollTextiles and Spinneybeck leathers may be ordered.	<i>Upholstery:</i> High back chairs only available with full cover. Full covers are stretched over wire frame and attach to seat basket with hooks. Full cover replacement for High Back Chairs fit all Bertoia High Back Chairs manufactured since 1952 within a limited range of tolerance.
C Polished Chrome	<i>Maintenance:</i> See pages 28-29.	
U Full cover	<i>Note:</i> The Knoll logo is stamped into the base of the chair and bench.	
K1084/9 Harrison, Dunbar	Customer's Own Material is available pending approval. For approval requirements, processing instructions and ordering information please see page 18.	The Bertoia Bird Lounge Seating is Greenguard certified.



- Specify:*
1. Pattern number
 2. Finish selection
 3. Upholstery option
 4. Textile selection
- For cushion replacement, specify:*
1. Pattern number
 2. Textile selection

Approved KnollTextiles Grades/Fabrics		
A Common Ground Crossroad Delite Hourglass Mariner Presto Sonnet Trophy Uni-Form	C Classic Boucle # Entourage Pullman Swing	H Arno Bavaria Magritte Stretch Appeal
B Diva Ferry Helios Journey Keaton Knoll Felt Knoll Hopsack Little Devil Synth	E Aegean Highland	I Cato Dynamic Ita Knoll Velvet North Island Vermeer Zimba
	F Atelier Cornaro Intrigue In Stitches	
	G Alter Ego Haze Melange Modern Tweed Ultrasuede	

Check with your KnollTextiles Representative for changes or additions.

Harry Bertoia

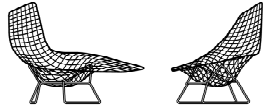
Asymmetric Chaise

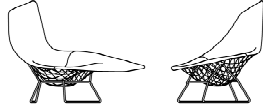
	description	seat h	w	d	h	textile fabric yds.	weight
<i>Designer(s):</i> Harry Bertoia, 1952	429L Asymmetric Chaise, unupholstered, with glides		52"	38 1/2"	40 1/4"		23 lbs.
<i>Award(s):</i> Honorable Mention, Annual Design Awards, ID Magazine 2006							
	429L Asymmetric Chaise, seat pad, with glides		52"	38 1/2"	40 1/4"	2.5	24 lbs.
							
	429K Seat cushion replacement					2.5	
	429L Asymmetric Chaise, fully upholstered, with glides		52"	38 1/2"	40 1/4"	4.5	22 lbs.
							
	429F Full cover replacement					4.5	

pattern no.	grades	COM	C	D	E	F	G	H	I	
429L-()		\$10,754.								
429L-()-K		11,547.	11,626.	11,704.	11,789.	11,859.	11,913.	11,997.	12,164.	12,282.
429K-()		844.	920.	995.	1,075.	1,142.	1,188.	1,272.	1,425.	1,539.
429L-()-U		12,321.	12,466.	12,609.	12,763.	12,888.	12,982.	13,137.	13,432.	13,647.
429F-()		2,011.	2,150.	2,282.	2,428.	2,548.	2,635.	2,781.	3,060.	3,261.

Order Code

<i>Example:</i>	429L-C-U-K1152/8
429L	Asymmetric chaise
C	Polished Chrome
U	Fully upholstered
K1152/8	Stirling, Cobble

Specify:

1. Pattern number
2. Frame finish
3. Upholstery option
4. Textile selection

For seat cushion replacement specify:

1. Pattern number
2. Textile selection

Ordering Information

Frame finishes:
Chrome (suffix C)
White (suffix 2)

Upholstery options:
Fully upholstered (suffix U)
Seat cushion only (suffix K)

Upholstery/COM information:

Prices shown include fabric or leather upholstery. Contact your Knoll representative for colors. Only approved KnollTextiles and Spinneybeck leathers may be ordered.

Customer's Own Material is available pending approval. For approval requirements, processing instructions and ordering information please see page 18.

Outdoor Use:

With proper care and limited exposure to the elements, the 429 Bertoia Asymmetric chaise is appropriate for outdoor environments. Specify rilsan finish. Consult a Knoll representative for appropriate upholstery options.

Cal 133 Fire Code #:

The Asymmetric chaise complies with the California Technical Bulletin 133 standard if upholstered in Cal 133 approved KnollTextiles. Specify suffix -C at end of pattern number and suffix -133 at end of textile selection.

Maintenance:

See pages 28-29.

Note:

The Knoll logo is stamped into the base of the Chaise.

The Bertoia Asymmetric Chaise is Greenguard certified.

Construction

Frame:

Welded steel rods in polished chrome or bonded white rilsan, a very durable and adhesive fused nylon-dipped finish. Scratch, chip and chemical resistant. Chrome chair features chrome connections. White rilsan chair features stainless steel connections suitable for outdoor use. Holes are drilled for the glides, and are included with the Chaise.

Upholstery:

Seat cushion secured to chair with lock-snaps. Full covers are stretched over wire frame and attach with hooks. Seat cushions and full covers will ship already attached to the chaise. If ordering a full cover replacement, installation must be performed by Knoll Field Services.

Approved KnollTextiles Grades/Fabrics

A Common Ground **	C Classic Boucle # Entourage Pullman Swing * Theory *	F Atelier Cornaro Intrigue In Stitches *	H Arno ** Bavaria Magritte Stretch Appeal
B Diva Ferry Journey Keaton Knoll Felt Knoll Hopsack Little Devil Ransom * Synth Venue * Vinyl *	E Aegean Highland	G Alter Ego Haze * Melange Modern Tweed Ultrasuede * Utrillo *	I Dynamic Ita Knoll Velvet * North Island Vermeer Zimba

* Available on seat cushion only.
** Available on full cover only.

Check with your KnollTextiles Representative for changes or additions.

Harry Bertoia Bench

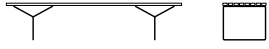
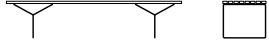
	description	seat h	w	d	h	textile fabric yds.	req.leather sq. ft.	weight	frame
<i>Designer(s):</i> Harry Bertoia, 1952	400Y Bench	15 1/4"	72"	19"	15 1/4"			32 lbs.	Chrome
									
	400K Seat cushion (one of maximum three)		19"	19"	3"	1.2	15	2 lbs.	
	410Y Outdoor Teak Bench	15 1/4"	72"	19"	15 1/4"			32 lbs.	Paint
									
		15 1/4"	72"	19"	15 1/4"			32 lbs.	Stainless
	410K Outdoor Seat cushion (one of maximum three)		19"	19"	3"	1.2	15	2 lbs.	

Order Code

<i>Example:</i>	400Y-CBL
400Y	Bench
C1	Chrome frame with black slats
<i>Example:</i>	400K-H800/19
400K	Seat cushion
H800/19	Cato, Fire Red
<i>Example:</i>	410K-K1557/8
410K	Outdoor Seat Cushion
K1557/8	Baxter, Hazel

Specify:

1. Pattern number
2. Frame/Slat finish selection
3. Seat cushion option
4. Textile selection

For seat cushion only, specify:

1. Pattern number
2. Textile selection

Ordering Information

Bench frame/slat finish combinations:
 Chrome/black (suffix CBL)
 Chrome/white (suffix CW)
 Black/teak (suffix BLK)
 White/teak (suffix WK)
 Stainless/teak (suffix SK)

Upholstery/COM information:

Prices shown include fabric or leather upholstery. Contact your Knoll representative for colors. Only approved KnollTextiles and Spinneybeck leathers may be ordered.

Customer's Own Material is available pending approval. For approval requirements, processing instructions and ordering information please see page 18.

Maintenance:

See pages 28-29.

Note:

The Knoll logo is stamped into the base of the bench.

Construction

Bench platform:

Solid wood horizontal slats pre-treated to help prevent sagging or warping. Slats in black or white painted finish and teak. Base wire diameter measures 12mm.

Platform bench cushion available separately: firm foam cushions upholstered with welt detail. Three cushions maximum per bench.

Outdoor use:

With proper care and preventative maintenance, benches specified with painted or stainless steel base and teak slats are appropriate for outdoor use.

To specify outdoor bench cushions, use pattern number 410K and appropriate outdoor upholstery.

Outdoor paint:

Ultra-durable polyester powder coat paint.

pattern no.	grades	COM																		
	A	B	C	D	E	F	G	H	I	COL	U	V	W	X	Y					
400Y-(CBL,CW)	\$3,697.																			
400K-()	486.	536.	581.	634.	677.	709.	759.	859.	934.	1,026.	1,150.	1,401.	1,456.	1,513.						
410Y-(BLK,WK)	2,730.																			
410Y-SK	3,449.																			
410K-()	0.	536.	581.	0.	0.	0.	0.	0.	0.	0.	0.	0.	0.	0.	0.					

Approved KnollTextiles Grades/Fabrics

A Alignment Bocce Cat's Cradle Chance Commuter Cloth Crossroad Delite Dristi Foil Rap Heavy Metal Hourglass Mariner Monarch Overture Prep Presto Soliloquy Sonnet Trophy Uni-Form	B continued Little Devil Ludlow Melody Mini Stitch Paradigm Petal Pusher Pogo Prairie * Prim Radianee Ransom Roam Rush Hour Spark Spree Summit Sutton Synth Tabloid Tinge Venue Versa Vinyl Westwood Wide Angle Zipline	C continued Enmesh Entourage Essence Fable CR Fibra Greenwich Hudson Hula Hoop Kaleidoscope CR Kaya CR Kora CR Lagos Legend CR Lore CR Metro Milestone Moto CR Noble * Palisade Panache CR Pullman Quark Roundtrip Sahara Sashiko Sequin CR Sinclair * Smart Spectator Spot On Star Struck Stepping Stones Swing Tilden Tower Grid Treble CR Wit Zari CR Zen Wave	D continued Kabuki Masquerade Menagerie Origins Woodland Zoom E Aegean Cleo Demure Highland Ikat Stripe Juno Katazome Kimono Mamba Marquee Meroe Midpoint Nature Walk Sherman Shima Tryst Vatera	F Alter Ego Arber Gibson Haze Kamani Melange Modern Tweed Petite Floral Serendipity Spencer Straie Stripe Ultrasuede Utrillo H Arno Bavaria Catwalk Constance Firefly	G Alter Ego Arber Gibson Haze Kamani Melange Modern Tweed Petite Floral Serendipity Spencer Straie Stripe Ultrasuede Utrillo	H continued Magritte Stretch Appeal I Aswan Byron Cato Cummings Diamond Days Dynamic Ita Jaipur Knoll Velvet Limani North Island Olema Piper Rutledge Sandis Tudor Vermeer Zimba	U Vicenza Volo V Acqua Andes Embossed Tipped España Hand Tipped Maremma Velluto Pelle W Alaska Amazon Antique Derby Forte Lucente Sabrina Umbria	X Ducale Ducale Velour Y Cervo Copenhagen Distressed Gemma Lucca Marissa Portofino Riva Saddle Torello
--	--	---	--	--	--	---	--	---

Spinneybeck Leather

U Vicenza Volo	V Acqua Andes Embossed Tipped España Hand Tipped Maremma Velluto Pelle	W Alaska Amazon Antique Derby Forte Lucente Sabrina Umbria	X Ducale Ducale Velour	Y Cervo Copenhagen Distressed Gemma Lucca Marissa Portofino Riva Saddle Torello
-----------------------------	--	---	-------------------------------------	--

*Appropriate for outdoor use. Specify 410K.

Check with your KnollTextiles or Spinneybeck Representative for changes or additions.

Pierre Beucler and Jean-Christophe Poggioli Architecture & Associés Contract Lounge Seating

Designer(s):
Pierre Beucler and
Jean-Christophe Poggioli, 2012



description	seat h	arm h	w	d	h	type	textile	leather	weight
							fabric yds	sq ft	
AAC4 AA Small Lounge chair, low back, std. wing, same upholstery, frame and cushions	16 1/2"	-	27 3/8"	32 3/4"	30 1/8"		4.4	81	-
AAC4 AA Small Lounge chair, low back, std. wing, combination upholstery, frame and cushions	-	-	-	-	-	frame uph.	2.4	41	-
						upchg, cushions	2.3	40	-
AAC1 AA Lounge chair, low back, std. wing, arm cushions, same upholstery, frame and cushions	16 1/2"	-	31 1/2"	32 3/4"	30 1/8"		6.3	113	-
AAC1 AA Lounge chair, low back, std. wing, arm cushions, combination upholstery, frame and cushions	-	-	-	-	-	frame uph.	3.2	50	-
						upchg, cushions	3.5	63	-

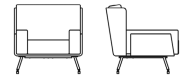
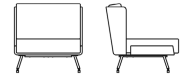

Order Code	Ordering Information	Construction
<i>Example:</i> AAC4-CU-K1479/6-K1406/7	<i>Leg finishes:</i> Chrome (suffix C) Copper (suffix CU)	<i>Frame:</i> Constructed in two formed plywood frames, back and seat, giving the pieces their architectural form. Frames are softened with highly resilient urethane foam wrapping.
AAC4 AA Small Lounge Chair	<i>Copper leg upcharge:</i> Copper leg finish is available at an upcharge of \$409 list. Use suffix CU to specify.	<i>Upholstery:</i> Interior loose cushions are available in either residential or contract versions. Contract cushions provide a tailored look for high use areas, while residential cushions convey a relaxed aesthetic. For units with combination upholstery, add list price of surround in appropriate grade with the list price of cushions to obtain total list price for item.
CU Copper legs		<i>Cushion fill:</i> "Contract" back and seat cushion are multi-density urethane foam.
K1479/6 Surround in Haiku, Storm		<i>Legs:</i> Machined steel legs feature height adjustable feet for leveling.
K1406/7 Cushions in Sonnet, Denim		
<i>Specify:</i> 1. Pattern number 2. Leg finish 3. Textile selection	<i>Upholstery/ COM information:</i> Prices shown includes fabric or leather upholstery. Contact your Knoll representative for colors. Only approved KnollTextiles and Spinneybeck leathers may be ordered.	
<i>Specify with split upholstery:</i> 1. Pattern number 2. Leg finish 3. Textile selection, Surround 4. Textile selection, Cushions	Customer's Own Material is available pending approval. For approval requirements, processing instructions and ordering information please see page 18.	
	<i>Maintenance:</i> See pages 28-29.	

pattern no.	grades	COM								COL				
	A	B	C	D	E	F	G	H	I	U	V	W	X	Y
AAC4-(-)(-)	\$4,154.	\$4,258.	\$4,359.	\$4,469.	\$4,558.	\$4,625.	\$4,734.	\$4,943.	\$5,100.	\$6,236.	\$6,620.	\$7,402.	\$7,566.	\$7,755.
AAC4S-(-)(-)	3,145.	3,202.	3,256.	3,317.	3,365.	3,401.	3,460.	3,574.	3,662.	4,140.	4,334.	4,732.	4,814.	4,911.
AAC4 cushions	1,229.	1,286.	1,337.	1,396.	1,442.	1,477.	1,535.	1,644.	1,725.	2,179.	2,368.	2,755.	2,835.	2,929.
AAC1-(-)(-)	4,562.	4,712.	4,856.	5,013.	5,143.	5,235.	5,393.	5,693.	5,916.	7,377.	7,912.	9,004.	9,232.	9,495.
AAC1S-(-)(-)	3,389.	3,467.	3,539.	3,619.	3,685.	3,733.	3,814.	3,966.	4,078.	4,573.	4,811.	5,294.	5,393.	5,510.
AAC1 cushions	1,401.	1,485.	1,565.	1,653.	1,724.	1,775.	1,863.	2,030.	2,154.	2,886.	3,186.	3,794.	3,922.	4,068.

Approved KnollTextiles Grades/Fabrics						Spinneybeck Leather	
A Chance Common Ground Commuter Cloth Crossroad Delite Dristi Hourglass Mariner Overture Prep * Presto * Sonnet Trophy Uni-Form *	B continued Pogo * Prairie * Ransom Rush Hour Spark * Summit Sutton Synth * Tinge Venue * Westwood * Wide Angle Zipline	C continued Milestone * Palisade Panache * Quark * Sahara Sequin CR * Spot On Stepping Stones * Swing Tilden * D Eclat Weave * Menagerie	E Aegean Highland Katazome Sherman Shima F Atelier Calais Cotton Velvet * Cornaro Icon Liberty Rivington * Soon Topography *	G Alter Ego Haze Kamani * Melange Modern Tweed * Petite Floral Ultrasuede H Arno Magritte	I Cato Dynamic Knoll Velvet * [†] Piper * Rutledge Tudor Vermeer	U Vicenza Volo V Acqua Andes Embossed Tipped España Velluto Pelle W Alaska Amazon Antique Forte Sabrina [†] Not approved on frame [‡] Indicates fabrics without topstitching Knoll Felt/Ivory K1207/1 not approved	X Ducale Velour Y Cervo Copenhagen Distressed Marissa Riva Saddle

Check with your KnollTextiles or Spinneybeck Representative for additions or changes.

Pierre Beucler and Jean-Christophe Poggioli Architecture & Associés Contract Lounge Seating

Designer(s):
Pierre Beucler and
Jean-Christophe Poggioli, 2012



description	seat h	arm h	w	d	h	type	textile	leather	weight
							fabric yds	sq ft	
AAC2 AA Settee, low back, std. wing, arm cushions, same upholstery, frame and cushions	16 1/2"	—	58"	32 3/4"	30 1/8"		9.3	170	—
AAC2 AA Settee, low back, std. wing, arm cushions, combination upholstery, frame and cushions	—	—	—	—	—	frame uph.	4	70	—
						upchg. cushions	5.3	100	—
AAC3 AA Sofa, low back, std. wing, arm cushions, same upholstery, frame and cushions	16 1/2"	—	85 1/4"	32 3/4"	30 1/8"		11.5	225	—
AAC3 AA Sofa, low back, std. wing, arm cushions, combination upholstery, frame and cushions	—	—	—	—	—	frame uph.	4.7	90	—
						upchg. cushions	7.2	138	—

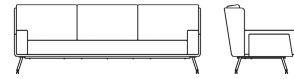
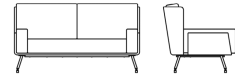

Order Code	Ordering Information	Construction
<i>Example:</i> AAC4-CU-K1479/6-K1406/7	<i>Leg finishes:</i> Chrome (suffix C) Copper (suffix CU)	<i>Frame:</i> Constructed in two formed plywood frames, back and seat, giving the pieces their architectural form. Frames are softened with highly resilient urethane foam wrapping.
AAC4 AA Small Lounge Chair	<i>Copper leg upcharge:</i> Copper leg finish is available at an upcharge of \$409 list. Use suffix CU to specify.	<i>Cushion fill:</i> "Contract" back and seat cushion are multi-density urethane foam.
CU Copper legs	<i>Upholstery/ COM information:</i> Prices shown includes fabric or leather upholstery. Contact your Knoll representative for colors. Only approved KnollTextiles and Spinneybeck leathers may be ordered.	<i>Legs:</i> Machined steel legs feature height adjustable feet for leveling.
K1479/6 Surround in Haiku, Storm	Customer's Own Material is available pending approval. For approval requirements, processing instructions and ordering information please see page 18.	<i>Upholstery:</i> Interior loose cushions are available in either residential or contract versions. Contract cushions provide a tailored look for high use areas, while residential cushions convey a relaxed aesthetic. For units with combination upholstery, add list price of surround in appropriate grade with the list price of cushions to obtain total list price for item.
K1406/7 Cushions in Sonnet, Denim	<i>Maintenance:</i> See pages 28-29.	

pattern no.	grades A	COM B	C	D	E	F	G	H	I	COL U	V	W	X	Y
AAC2-(-)(-)	\$6,440.	\$6,662.	\$6,872.	\$7,106.	\$7,296.	\$7,433.	\$7,666.	\$8,110.	\$8,438.	\$10,713.	\$11,520.	\$13,162.	\$13,503.	\$13,902.
AAC2S-(-)(-)	4,730.	4,825.	4,917.	5,015.	5,099.	5,156.	5,257.	5,449.	5,590.	6,407.	6,740.	7,417.	7,559.	7,721.
AAC2 cushions	2,042.	2,167.	2,287.	2,421.	2,529.	2,607.	2,739.	2,992.	3,179.	4,404.	4,881.	6,983.	6,047.	6,282.
AAC3-(-)(-)	8,230.	8,503.	8,764.	9,053.	9,288.	9,459.	9,746.	10,295.	10,700.	13,932.	15,001.	17,174.	17,627.	18,153.
AAC3S-(-)(-)	5,950.	6,062.	6,169.	6,286.	6,382.	6,451.	6,569.	6,792.	6,959.	8,129.	8,556.	9,424.	9,606.	9,817.
AAC3 cushions	2,735.	2,908.	3,072.	3,251.	3,399.	3,505.	3,685.	4,029.	4,282.	5,998.	6,654.	7,987.	8,264.	8,589.



Approved KnollTextiles Grades/Fabrics						Spinneybeck Leather	
A Chance Common Ground Commuter Cloth Crossroad Delite Dristi Hourglass Mariner Overture Prep * Presto * Sonnet Trophy Uni-Form *	B continued Pogo * Prairie * Ransom Rush Hour Spark * Summit Sutton Synth * Tinge Venue * Westwood * Wide Angle Zipline	C continued Milestone * Palisade Panache * Quark * Sahara Sequin CR * Spot On Stepping Stones * Swing Tilden * D Eclat Weave * Menagerie	E Aegean Highland Katazome Sherman Shima F Atelier Calais Cotton Velvet * Cornaro Icon Liberty Rivington * Soon Topography *	G Alter Ego Haze Kamani * Melange Modern Tweed * Petite Floral Ultrasuede H Arno Magritte	I Cato Dynamic Knoll Velvet * [†] Piper * Rutledge Tudor Vermeer	U Vicenza Volo V Acqua Andes Embossed Tipped España Velluto Pelle W Alaska Amazon Antique Forte Sabrina [‡] Not approved on frame [†] Indicates fabrics without topstitching Knoll Felt/Ivory K1207/1 not approved	X Ducale Velour Y Cervo Copenhagen Distressed Marissa Riva Saddle

Check with your KnollTextiles or Spinneybeck Representative for additions or changes.

Pierre Beucler and Jean-Christophe Poggioli Architecture & Associés Contract Lounge Seating

Designer(s):
Pierre Beucler and
Jean-Christophe Poggioli, 2012



description	seat h	arm h	w	d	h	type	textile fabric yds	leather sq ft	weight
AAC5 AA Small Ottoman, same upholstery, frame and cushions 	–	–	27 1/2"	24 1/2"	16"		2.2	40	–
AAC5 AA Small Ottoman, combination upholstery, frame and cushions	–	–	–	–	–	frame uph.	1.2	18	–
	–	–	–	–	–	upchg, cushions	1.3	22	–
AAC6 AA Medium Ottoman, same upholstery, frame and cushions 	–	–	31 1/8"	29 1/2"	16"		3.3	60	–
AAC6 AA Medium Ottoman, combination upholstery, frame and cushions	–	–	–	–	–	frame uph.	1.8	28	–
	–	–	–	–	–	upchg, cushions	2.3	32	–
AAC7 AA Large Ottoman, same upholstery, frame and cushions 	–	–	59"	29 1/2"	16 1/2"		4.5	70	–
AAC7 AA Large Ottoman, combination upholstery, frame and cushions	–	–	–	–	–	frame uph.	2.2	31	–
	–	–	–	–	–	upchg, cushions	2.7	43	–

pattern no.	grades A	COM B	C	D	E	F	G	H	I	COL U	V	W	X	Y
AAC5-(-)(-)	\$2,434.	\$2,489.	\$2,538.	\$2,592.	\$2,638.	\$2,670.	\$2,725.	\$2,830.	\$2,907.	\$3,491.	\$3,681.	\$4,067.	\$4,149.	\$4,241.
AAC5S-(-)(-)(-)	1,851.	1,880.	1,906.	1,938.	1,961.	1,979.	2,009.	2,068.	2,222.	2,281.	2,366.	2,541.	2,576.	2,619.
AAC5 cushions	734.	765.	796.	828.	855.	874.	906.	968.	1,014.	1,251.	1,356.	1,568.	1,613.	1,665.
AAC6-(-)(-)	2,565.	2,643.	2,718.	2,800.	2,867.	2,916.	2,999.	3,155.	3,273.	4,083.	4,368.	4,949.	5,069.	5,210.
AAC6S-(-)(-)(-)	1,927.	1,971.	2,011.	2,057.	2,094.	2,121.	2,165.	2,251.	2,315.	2,584.	2,720.	2,990.	3,045.	3,112.
AAC6 cushions	823.	878.	930.	988.	1,034.	1,068.	1,127.	1,238.	1,318.	1,540.	1,691.	2,000.	2,065.	2,139.
AAC7-(-)(-)	3,885.	3,993.	4,094.	4,207.	4,298.	4,365.	4,477.	4,692.	4,852.	5,698.	6,049.	6,764.	6,913.	7,087.
AAC7S-(-)(-)(-)	2,985.	3,037.	3,086.	3,142.	3,187.	3,220.	3,274.	3,380.	3,457.	3,694.	3,842.	4,142.	4,204.	4,276.
AAC7 cushions	1,059.	1,123.	1,184.	1,252.	1,308.	1,348.	1,414.	1,543.	1,639.	2,045.	2,248.	2,663.	2,751.	2,852.

Order Code

<i>Example:</i>	AAC7-C-K1617/3
AAC7	AA Large Ottoman
C	Chrome legs
K1617/3	Dynamic, Radiant

Specify:

1. Pattern number
2. Leg finish
3. Textile selection

Specify with split upholstery:

1. Pattern number
2. Leg finish
3. Textile selection, Surround
4. Textile selection, Cushions

Ordering Information

Leg finishes:

Chrome (suffix C)
Copper (suffix CU)

Copper leg upcharge:

Copper leg finish is available at an upcharge of \$409 list. Use suffix CU to specify.

Upholstery/ COM information:

Prices shown includes fabric or leather upholstery. Contact your Knoll representative for colors. Only approved KnollTextiles and Spinneybeck leathers may be ordered.

Customer's Own Material is available pending approval. For approval requirements, processing instructions and ordering information please see page 18.

Maintenance:

See pages 28-29.

Construction

Frame:

Constructed in two formed plywood frames, back and seat, giving the pieces their architectural form. Frames are softened with highly resilient urethane foam wrapping.

Upholstery:

Interior loose cushions are available in either residential or contract versions. Contract cushions provide a tailored look for high use areas, while residential cushions convey a relaxed aesthetic. For units with combination upholstery, add list price of surround in appropriate grade with the list price of cushions to obtain total list price for item.

Cushion fill:

"Contract" back and seat cushion are multi-density urethane foam.

Legs:

Machined steel legs feature height adjustable feet for leveling.

Approved KnollTextiles Grades/Fabrics

A Chance Common Ground Commuter Cloth Crossroad Delite Dristi Hourglass Mariner Overture Prep * Presto * Sonnet Trophy	B Argyle * Belize * Calypso Cameo Chroma Diva Ferry * Helios Journey Knoll Felt Knoll Hopsack Little Devil Ludlow	C continued Melody Pogo * Prairie * Ransom Rush Hour Spark * Summit Sutton Synth Tinge Venue * Westwood * Wide Angle Zipline	D Eclat Weave * Menagerie	E Aegean Highland Katazome Sherman Shima	F Atelier Calais Cotton Velvet * Cornaro Icon Liberty Rivington * Soon Topography *	G Alter Ego Haze Kamani * Melange Petite Floral Ultrasuede	H Arno Magritte	I Cato Dynamic Knoll Velvet *† Piper * Rutledge Tudor Vermeer	U Vicenza Volo	V Acqua Andes Embossed Tipped España Velluto Pelle	W Alaska Amazon Antique Forte Satin Unapproved on frame Unbricates fabrics without topstitching Knoll Felt/Ivory K1207/1 not approved	X Ducale Velour	Y Cervo Copenhagen Distressed Marissa Riva Saddle
--	---	---	--	--	---	---	------------------------------	---	-----------------------------	--	--	---------------------------	--

Spinneybeck Leather

U Vicenza Volo	V Acqua Andes Embossed Tipped España Velluto Pelle	W Alaska Amazon Antique Forte Satin Unapproved on frame Unbricates fabrics without topstitching Knoll Felt/Ivory K1207/1 not approved	X Ducale Velour	Y Cervo Copenhagen Distressed Marissa Riva Saddle
-----------------------------	--	--	---------------------------	--

Check with your KnollTextiles or Spinneybeck Representative for additions or changes.

Pierre Beucler and Jean-Christophe Poggioli Architecture & Associés Residential Lounge Seating

Designer(s):
Pierre Beucler and
Jean-Christophe Poggioli, 2012



description	seat h	arm h	w	d	h	type	textile	leather	weight
							fabric yds	sq ft	
AAR4 AA Small Lounge chair, low back, std. wing, same upholstery, frame and cushions	16 1/2"	—	27 3/8"	32 3/4"	30 1/8"		4.5	82	—
AAR4 AA Small Lounge chair, low back, std. wing, combination upholstery, frame and cushions	—	—	—	—	—	from uph.	2.4	42	—
	—	—	—	—	—	upchg, cushions	2.5	40	—
AAR1 AA Lounge chair, low back, std. wing, arm cushions, same upholstery, frame and cushions	16 1/2"	—	31 1/2"	32 3/4"	30 1/8"		6.4	118	—
AAR1 AA Lounge chair, low back, std. wing, arm cushions, combination upholstery, frame and cushions	—	—	—	—	—	frame uph.	3.1	50	—
	—	—	—	—	—	upchg, cushions	4.7	68	—



Order Code	Ordering Information	Construction
<i>Example:</i> AAR1-CU-CV44-H800/2	<i>Leg finishes:</i> Chrome (suffix C) Copper (suffix CU)	<i>Frame:</i> Constructed in two formed plywood frames, back and seat, giving the pieces their architectural form. Frames are softened with highly resilient urethane foam wrapping.
AAR1 AA Lounge Chair	<i>Copper leg upcharge:</i> Copper leg finish is available at an upcharge of \$409 list. Use suffix CU to specify.	<i>Cushion fill:</i> "Residential" back cushion is 100% polyester fiber and the seat is a multi-density urethane foam.
CU Copper legs	<i>Upholstery/ COM information:</i> Prices shown includes fabric or leather upholstery. Contact your Knoll representative for colors. Only approved KnollTextiles and Spinneybeck leathers may be ordered.	<i>Legs:</i> Machined steel legs feature height adjustable feet for leveling.
CV44 Surround in Cervo, Lessinia	Customer's Own Material is available pending approval. For approval requirements, processing instructions and ordering information please see page 18.	<i>Upholstery:</i> Interior loose cushions are available in either residential or contract versions. Contract cushions provide a tailored look for high use areas, while residential cushions convey a relaxed aesthetic. For units with combination upholstery, add list price of surround in appropriate grade with the list price of cushions to obtain total list price for item.
H800/2 Cushions in Cato, Sand	<i>Maintenance:</i> See pages 28-29.	

Specify:

1. Pattern number
2. Leg finish
3. Textile selection

Specify with split upholstery:

1. Pattern number
2. Leg finish
3. Textile selection, Surround
4. Textile selection, Cushions

pattern no.	grades	COM	C	D	E	F	G	H	I	COL	U	V	W	X	Y
AAR4-(-)(-)	\$4,140.	\$4,246.	\$4,349.	\$4,462.	\$4,554.	\$4,621.	\$4,734.	\$4,949.	\$5,106.	\$6,242.	\$6,631.	\$7,424.	\$7,587.	\$7,780.	
AAR4S-(-)(-)	3,131.	3,188.	3,243.	3,302.	3,351.	3,386.	3,448.	3,562.	3,645.	4,154.	4,352.	4,758.	4,844.	4,940.	
AAR4 cushions	1,240.	1,297.	1,355.	1,418.	1,468.	1,506.	1,568.	1,688.	1,775.	2,172.	2,361.	2,749.	2,829.	2,921.	
AAR1-(-)(-)	4,549.	4,702.	4,847.	5,007.	5,139.	5,232.	5,392.	5,698.	5,923.	7,491.	8,051.	9,190.	9,428.	9,704.	
AAR1S-(-)(-)	3,370.	3,443.	3,514.	3,592.	3,654.	3,701.	3,778.	3,927.	4,036.	4,558.	4,795.	5,279.	5,380.	5,496.	
AAR1 cushions	1,480.	1,593.	1,700.	1,817.	1,915.	1,983.	2,100.	2,323.	2,491.	3,015.	3,337.	3,995.	4,132.	4,291.	

Approved KnollTextiles Grades/Fabrics						Spinneybeck Leather							
A Chance Common Ground Commuter Cloth Crossroad Delite Dristi Hourglass Mariner Overture Prep * Presto * Sonnet Trophy	B Argyle * Belize * Calypso Cameo Chroma Diva Ferry * Helios Journey Knoll Felt Knoll Hopsack Little Devil Ludlow	C continued Melody Pogo * Prairie * Ransom Rush Hour Spark * Summit Sutton Synth * Tinge Venue * Westwood * Wide Angle Zipline	D Eclat Weave * Menagerie	E Aegean Highland Katazome Sherman Shima	F Atelier Calais Cotton Velvet * Cornaro Icon Liberty Rivington * Soon Topography *	G Alter Ego Haze Kamani * Melange Petite Floral Ultrasuede	H Arno Magritte	I Cato Dynamic Knoll Velvet *† Piper Rutledge Tudor Vermeer	U Vicenza Volo	X Ducale Velour	Y Cervo Copenhagen Distressed Marissa Riva Saddle	V Acqua Andes Embossed Tipped España Velluto Pelle	W Alaska Amazon Antique Forte Satin Unapproved on frame Unbricates fabrics without topstitching Knoll Felt/Ivory K1207/1 not approved

Check with your KnollTextiles or Spinneybeck Representative for additions or changes.

Pierre Beucler and Jean-Christophe Poggioli

Architecture & Associés

Residential Lounge Seating

Designer(s):
Pierre Beucler and
Jean-Christophe Poggioli, 2012

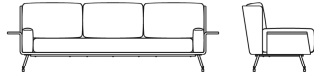

description	seat h	arm h	w	d	h	type	textile	leather	weight
							fabric yds	sq ft	
AAR2 AA Settee, low back, std. wing, arms, arm cushions, same upholstery, frame and cushions	16 1/2"	—	69 1/2"	32 3/4"	30 1/8"		9.5	177	—
						frame	4.3	76	—
						upchg. cushions	6.7	101	—
AAR3 AA Sofa, low back, std. wing, arms, arm cushions, same upholstery, frame and cushions	16 1/2"	—	97"	32 3/4"	30 1/8"		12.5	231	—
						frame uph.	5.4	93	—
						upchg. cushions	8.5	138	—

pattern no.	grades	COM	C	D	E	F	G	H	I	COL	U	V	W	X	Y
AAR2-(-)(-)	\$6,455.	\$6,681.	\$6,897.	\$7,134.	\$7,328.	\$7,469.	\$7,707.	\$8,161.	\$8,495.	\$10,902.	\$11,744.	\$13,453.	\$13,809.	\$14,223.	
AAR2S-(-)(-)	4,751.	4,854.	4,952.	5,060.	5,147.	5,211.	5,318.	5,523.	5,674.	6,571.	6,931.	7,665.	7,819.	7,996.	
AAR2 cushions	2,141.	2,302.	2,454.	2,620.	2,758.	2,857.	3,024.	3,345.	3,580.	4,432.	4,913.	5,887.	6,092.	6,327.	
AAR3-(-)(-)	8,292.	8,592.	8,875.	9,188.	9,443.	9,628.	9,939.	10,537.	10,978.	14,087.	15,184.	17,416.	17,880.	18,420.	
AAR3S-(-)(-)	5,994.	6,121.	6,245.	6,379.	6,490.	6,571.	6,705.	6,963.	7,154.	8,205.	8,644.	9,544.	9,732.	9,950.	
AAR3 cushions	2,827.	3,028.	3,222.	3,434.	3,608.	3,736.	3,947.	4,352.	4,651.	5,996.	6,652.	7,985.	8,262.	8,584.	

Order Code	Ordering Information	Construction
<i>Example:</i> AAR1-CU-CV44-H800/2	<i>Leg finishes:</i> Chrome (suffix C) Copper (suffix CU)	<i>Frame:</i> Constructed in two formed plywood frames, back and seat, giving the pieces their architectural form. Frames are softened with highly resilient urethane foam wrapping.
AAR1 AA Lounge Chair		<i>Cushion fill:</i> "Residential" back cushion is 100% polyester fiber and the seat is a multi-density urethane foam.
CU Copper legs	<i>Copper leg upcharge:</i> Copper leg finish is available at an upcharge of \$409 list. Use suffix CU to specify.	<i>Legs:</i> Machined steel legs feature height adjustable feet for leveling.
CV44 Surround in Cervo, Lessinia		<i>Upholstery:</i> Interior loose cushions are available in either residential or contract versions. Contract cushions provide a tailored look for high use areas, while residential cushions convey a relaxed aesthetic. For units with combination upholstery, add list price of surround in appropriate grade with the list price of cushions to obtain total list price for item.
H800/2 Cushions in Cato, Sand	<i>Upholstery/ COM information:</i> Prices shown includes fabric or leather upholstery. Contact your Knoll representative for colors. Only approved KnollTextiles and Spinneybeck leathers may be ordered.	
<i>Specify:</i> 1. Pattern number 2. Leg finish 3. Textile selection	<i>Customer's Own Material</i> is available pending approval. For approval requirements, processing instructions and ordering information please see page 18.	
<i>Specify with split upholstery:</i> 1. Pattern number 2. Leg finish 3. Textile selection, Surround 4. Textile selection, Cushions	<i>Maintenance:</i> See pages 28-29.	

Approved KnollTextiles Grades/Fabrics						Spinneybeck Leather							
A Chance Common Ground Commuter Cloth Crossroad Delite Dristi Hourglass Mariner Overture Prep * Presto * Sonnet Trophy	B Argyle * Belize * Calypso Cameo Chroma Diva Ferry * Helios Journey Knoll Felt Knoll Hopsack Little Devil Ludlow	C continued Melody Pogo * Prairie * Ransom Rush Hour Spark * Summit Sutton Synth * Tinge Venue * Westwood * Wide Angle Zipline	D Eclat Weave * Menagerie	E Aegean Highland Katazome Sherman Shima	F Atelier Calais Cotton Velvet * Cornaro Icon Liberty Rivington * Soon Topography *	G Alter Ego Haze Kamani * Melange Petite Floral Ultrasuede	H Arno Magritte	I Cato Dynamic Knoll Velvet *† Piper Rutledge Tudor Vermeer	U Vicenza Volo	X Ducale Velour	Y Cervo Copenhagen Distressed Marissa Riva Saddle	V Acqua Andes Embossed Tipped España Velluto Pelle	W Alaska Amazon Antique Forte Satin Unapproved on frame Unbricates fabrics without topstitching Knoll Felt/Ivory K1207/1 not approved

Check with your KnollTextiles or Spinneybeck Representative for additions or changes.

Pierre Beucler and Jean-Christophe Poggioli Architecture & Associés Residential Lounge Seating

Designer(s):
Pierre Beucler and
Jean-Christophe Poggioli, 2012



description	seat h	arm h	w	d	h	type	textile fabric yds	leather sq ft	weight
AAR8 AA Lounge chair, high back, std. wing, arm cushions, same upholstery, frame and cushions	16 1/2"	–	31 1/2"	36"	36 3/8"		7.3	132	–
AAR8 AA Lounge chair, high back, std. wing, arm cushions, combination upholstery, frame and cushions	–	–	–	–	–	frame uph.	3.6	60	–
	–	–	–	–	–	upchg. cushions	4.5	72	–
AAR9 AA Settee, high back, std. wing, arms, arm cushions, same upholstery, frame and cushions	16 1/2"	–	69 1/2"	36"	36 3/8"		11.2	203	–
AAR9 AA Settee, high back, std. wing, arms, arm cushions, combination upholstery, frame and cushions	–	–	–	–	–	frame uph.	5	89	–
	–	–	–	–	–	upchg. cushions	6.8	114	–



Order Code	Ordering Information	Construction
<i>Example:</i> AAR9-C-PR34-K128/3	<i>Leg finishes:</i> Chrome (suffix C) Copper (suffix CU)	<i>Frame:</i> Constructed in two formed plywood frames, back and seat, giving the pieces their architectural form. Frames are softened with highly resilient urethane foam wrapping.
AAR9 AA Settee, high back	<i>Copper leg upcharge:</i> Copper leg finish is available at an upcharge of \$409 list. Use suffix CU to specify.	<i>Cushion fill:</i> "Residential" back cushion is 100% polyester fiber and the seat is a multi-density urethane foam.
C Chrome legs	<i>Upholstery/ COM information:</i> Prices shown includes fabric or leather upholstery. Contact your Knoll representative for colors. Only approved KnollTextiles and Spinneybeck leathers may be ordered.	<i>Legs:</i> Machined steel legs feature height adjustable feet for leveling.
PR34 Surround in Prima, Scarlatti	Customer's Own Material is available pending approval. For approval requirements, processing instructions and ordering information please see page 18.	<i>Upholstery:</i> Interior loose cushions are available in either residential or contract versions. Contract cushions provide a tailored look for high use areas, while residential cushions convey a relaxed aesthetic. For units with combination upholstery, add list price of surround in appropriate grade with the list price of cushions to obtain total list price for item.
K128/3 Cushions in Arno, Obsidian	<i>Maintenance:</i> See pages 28-29.	

Specify:

1. Pattern number
2. Leg finish
3. Textile selection

Specify with split upholstery:

1. Pattern number
2. Leg finish
3. Textile selection, Surround
4. Textile selection, Cushions

pattern no.	grades A	COM B	C	D	E	F	G	H	I	COL U	V	W	X	Y
AAR8-(-)(-)	\$4,634.	\$4,809.	\$4,973.	\$5,156.	\$5,306.	\$5,414.	\$5,597.	\$5,946.	\$6,204.	\$7,890.	\$8,519.	\$9,793.	\$10,060.	\$10,367.
AAR8S-(-)(-)	3,420.	3,505.	3,587.	3,676.	3,750.	3,803.	3,894.	4,065.	4,192.	4,844.	5,128.	5,709.	5,828.	5,970.
AAR8 cushions	1,473.	1,581.	1,683.	1,795.	1,888.	1,954.	2,066.	2,281.	2,439.	3,130.	3,472.	4,167.	4,313.	4,480.
AAR9-(-)(-)	6,756.	7,023.	7,278.	7,560.	7,788.	7,953.	8,233.	8,767.	9,162.	11,786.	12,752.	14,712.	15,121.	15,597.
AAR9S-(-)(-)	4,922.	5,041.	5,154.	5,280.	5,382.	5,456.	5,581.	5,820.	5,996.	7,044.	7,466.	8,325.	8,505.	8,713.
AAR9 cushions	2,208.	2,369.	2,525.	2,694.	2,833.	2,934.	3,103.	3,429.	3,669.	4,845.	5,385.	6,486.	6,716.	6,984.

Approved KnollTextiles Grades/Fabrics	Spinneybeck Leather
A Chance Common Ground Commuter Cloth Crossroad Delite Dristi Hourglass Mariner Overture Prep * Presto * Sonnet Trophy	U Vicenza Volo V Acqua Andes Embossed Tipped España Velluto Pelle W Alaska Amazon Antique Forte Satin Nonapproved on frame Unbricates fabrics without topstitching Knoll Felt/Ivory K1207/1 not approved
B Argyle * Belize * Calypso Cameo Chroma Diva Ferry * Helios Journey Knoll Felt Knoll Hopsack Little Devil Ludlow	X Ducale Velour Y Cervo Copenhagen Distressed Marissa Riva Saddle
C continued Melody Pogo * Prairie * Ransom Rush Hour Spark * Summit Sutton Synth * Tinge Venue * Westwood * Wide Angle Zipline	I Cato Dynamic Knoll Velvet *† Piper * Rutledge Tudor Vermeer
D Eclat Weave * Menagerie	H Arno Magritte S Cornaro Icon Liberty Rivington * Soon Topography *
E Aegean Highland Katazome Sherman Shima	G Alter Ego Haze Kamani * Melange Petite Floral Ultrasuede
F Atelier Calais Cotton Velvet * Cornaro Liberty Rivington * Soon Topography *	

Check with your KnollTextiles or Spinneybeck Representative for additions or changes.

Pierre Beucler and Jean-Christophe Poggioli

Architecture & Associés

Residential Lounge Seating

Designer(s):
Pierre Beucler and
Jean-Christophe Poggioli, 2012



description	seat h	arm h	w	d	h	type	textile	leather	weight
							fabric yds	sq ft	
AAR10 AA Sofa, high back, std. wing, arms, arm cushions, same upholstery, frame and cushions	16 1/2"	—	97"	36"	36 3/8"		13.8	243	—
AAR10 AA Sofa, high back, std. wing, arms, arm cushions, combination upholstery, frame and cushions	—	—	—	—	—	frame uph.	6.1	110	—
	—	—	—	—	—	upchg, cushions	8.6	157	—
AAR11 AA Settee, high back, large wing, arms, same upholstery, frame and cushions	16 1/2"	—	69 1/2"	36"	36 3/8"		10.3	190	—
AAR11 AA Settee, high back, large wing, arms, combination upholstery, frame and cushions	—	—	—	—	—	frame uph.	5.5	97	—
	—	—	—	—	—	upchg, cushions	5	93	—

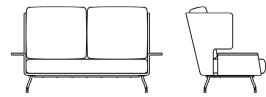

Order Code	Ordering Information	Construction
<i>Example:</i> AAR9-C-PR34-K128/3	<i>Leg finishes:</i> Chrome (suffix C) Copper (suffix CU)	<i>Frame:</i> Constructed in two formed plywood frames, back and seat, giving the pieces their architectural form. Frames are softened with highly resilient urethane foam wrapping.
AAR9 AA Settee, high back	<i>Copper leg upcharge:</i> Copper leg finish is available at an upcharge of \$409 list. Use suffix CU to specify.	<i>Cushion fill:</i> "Residential" back cushion is 100% polyester fiber and the seat is a multi-density urethane foam.
C Chrome legs		<i>Legs:</i> Machined steel legs feature height adjustable feet for leveling.
PR34 Surround in Prima, Scarlatti		<i>Upholstery:</i> Interior loose cushions are available in either residential or contract versions. Contract cushions provide a tailored look for high use areas, while residential cushions convey a relaxed aesthetic. For units with combination upholstery, add list price of surround in appropriate grade with the list price of cushions to obtain total list price for item.
K128/3 Cushions in Arno, Obsidian		
<i>Specify:</i>	<i>Upholstery/ COM information:</i> Prices shown includes fabric or leather upholstery. Contact your Knoll representative for colors. Only approved KnollTextiles and Spinneybeck leathers may be ordered.	
1. Pattern number		
2. Leg finish		
3. Textile selection		
<i>Specify with split upholstery:</i>	Customer's Own Material is available pending approval. For approval requirements, processing instructions and ordering information please see page 18.	
1. Pattern number		
2. Leg finish		
3. Textile selection, Surround		
4. Textile selection, Cushions		
	<i>Maintenance:</i> See pages 28-29.	

pattern no.	grades	COM	C	D	E	F	G	H	I	COL	V	W	X	Y
AAR10-(-)(-)	\$8,630.	\$8,959.	\$9,273.	\$9,616.	\$9,899.	\$10,104.	\$10,449.	\$11,106.	\$11,593.	\$14,654.	\$15,809.	\$18,155.	\$18,644.	\$19,213.
AAR10S-(-)(-)(-)	6,207.	6,352.	6,490.	6,642.	6,768.	6,858.	7,011.	7,303.	7,515.	8,826.	9,350.	10,412.	10,634.	10,890.
AAR10 cushions	2,914.	3,118.	3,313.	3,529.	3,706.	3,831.	4,047.	4,457.	4,760.	6,592.	7,338.	8,854.	9,169.	9,537.
AAR11-(-)(-)	7,294.	7,539.	7,773.	8,031.	8,242.	8,394.	8,651.	9,143.	9,506.	12,037.	12,940.	14,775.	15,156.	15,602.
AAR11S-(-)(-)(-)	5,361.	5,492.	5,617.	5,754.	5,868.	5,949.	6,085.	6,349.	6,543.	7,664.	8,124.	9,062.	9,256.	9,484.
AAR11 cushions	2,278.	2,396.	2,510.	2,636.	2,737.	2,811.	2,937.	3,175.	3,351.	4,473.	4,916.	5,814.	6,000.	6,218.

Approved KnollTextiles Grades/Fabrics						Spinneybeck Leather							
A Chance Common Ground Commuter Cloth Crossroad Delite Dristi Hourglass Mariner Overture Prep * Presto * Sonnet Trophy	B Argyle * Belize * Calypso Cameo Chroma Diva Ferry * Helios Journey Knoll Felt Knoll Hopsack Little Devil Ludlow	C continued Melody Pogo * Prairie * Ransom Rush Hour Summit Sutton Synth * Tinge Venue * Westwood * Wide Angle Zipline	D Eclat Weave * Menagerie	E Aegean Highland Katazome Sherman Shima	F Atelier Calais Cotton Velvet * Cornaro Icon Liberty Rivington * Soon Topography *	G Alter Ego Haze Kamani * Melange Petite Floral Ultrasuede	H Arno Magritte	I Cato Dynamic Knoll Velvet *† Piper * Rutledge Tudor Vermeer	U Vicenza Volo	X Ducale Velour	Y Cervo Copenhagen Distressed Marissa Riva Saddle	V Acqua Andes Embossed Tipped España Velluto Pelle	W Alaska Amazon Antique Forte Satin Unapproved on frame Unbricates fabrics without topstitching Knoll Felt/Ivory K1207/1 not approved

Check with your KnollTextiles or Spinneybeck Representative for additions or changes.

Pierre Beucler and Jean-Christophe Poggioli Architecture & Associés Residential Lounge Seating

Designer(s):
Pierre Beucler and
Jean-Christophe Poggioli, 2012



description	seat h	arm h	w	d	h	type	leather sq ft	textile fabric yds	weight
AAR12L AA Chaise, high back, large wing, left arm, same upholstery, frame and cushions	16 1/2"	—	35 1/2"	69"	36 3/8"		150	8.3	—
AAR12L AA Chaise, high back, large wing, left arm, combination upholstery, frame and cushions	—	—	—	—	—	frame	86	5.3	—
						upchg. cushions	64	4.4	—
AAR12R AA Chaise, high back, large wing, right arm, same upholstery, frame and cushions	16 1/2"	—	35 1/2"	69"	36 3/8"		150	8.3	—
AAR12R AA Chaise, high back, large wing, right arm, combination upholstery, frame and cushions	—	—	—	—	—	frame	86	5.3	—
						upchg. cushions	64	4.4	—

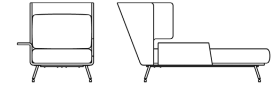
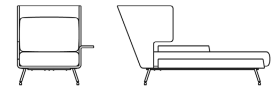

Order Code	Ordering Information	Construction
<i>Example:</i> AAR12L-CU-RA1805-K1021/5	<i>Leg finishes:</i> Chrome (suffix C) Copper (suffix CU)	<i>Frame:</i> Constructed in two formed plywood frames, back and seat, giving the pieces their architectural form. Frames are softened with highly resilient urethane foam wrapping.
AAR12L AA Chaise, left arm	<i>Copper leg upcharge:</i> Copper leg finish is available at an upcharge of \$409 list. Use suffix CU to specify.	<i>Upholstery:</i> Interior loose cushions are available in either residential or contract versions. Contract cushions provide a tailored look for high use areas, while residential cushions convey a relaxed aesthetic. For units with combination upholstery, add list price of surround in appropriate grade with the list price of cushions to obtain total list price for item.
CU Copper legs		
RA1805 Surround in Riva, Labbo		
K1021/5 Cushions in Ultrasuede, Aztec		
<i>Specify:</i> 1. Pattern number 2. Leg finish 3. Textile selection	<i>Upholstery/ COM information:</i> Prices shown includes fabric or leather upholstery. Contact your Knoll representative for colors. Only approved KnollTextiles and Spinneybeck leathers may be ordered.	<i>Cushion fill:</i> "Residential" back cushion is 100% polyester fiber and the seat is a multi-density urethane foam.
<i>Specify with split upholstery:</i> 1. Pattern number 2. Leg finish 3. Textile selection, Surround 4. Textile selection, Cushions	Customer's Own Material is available pending approval. For approval requirements, processing instructions and ordering information please see page 18.	<i>Legs:</i> Machined steel legs feature height adjustable feet for leveling.
	<i>Maintenance:</i> See pages 28-29.	

pattern no.	grades A	COM B	C	D	E	F	G	H	I	COL U	V	W	X	Y
AAR12L-(-)(-)	\$7,011.	\$7,209.	\$7,398.	\$7,606.	\$7,775.	\$7,897.	\$8,105.	\$8,501.	\$8,793.	\$10,813.	\$11,525.	\$12,975.	\$13,276.	\$13,628.
AAR12LS-(-)(-)	5,334.	5,460.	5,581.	5,714.	5,822.	5,900.	6,033.	6,286.	6,472.	7,353.	7,762.	8,594.	8,764.	8,967.
AAR12L cushions	2,107.	2,212.	2,313.	2,423.	2,512.	2,577.	2,687.	2,898.	3,053.	3,561.	3,864.	4,482.	4,611.	4,761.
AAR12R-(-)(-)	7,011.	7,209.	7,398.	7,606.	7,775.	7,897.	8,105.	8,501.	8,793.	10,813.	11,525.	12,975.	13,276.	13,628.
AAR12RS-(-)(-)	5,334.	5,460.	5,581.	5,714.	5,822.	5,900.	6,033.	6,286.	6,472.	7,353.	7,762.	8,594.	8,764.	8,967.
AAR12R cushions	2,107.	2,212.	2,313.	2,423.	2,512.	2,577.	2,687.	2,898.	3,053.	3,561.	3,864.	4,482.	4,611.	4,761.

Approved KnollTextiles Grades/Fabrics						Spinneybeck Leather							
A Chance Common Ground Commuter Cloth Crossroad Delite Dristi Hourglass Mariner Overture Prep * Presto * Sonnet Trophy	B Argyle * Belize * Calypso Cameo Chroma Diva Ferry * Helios Journey Knoll Felt Knoll Hopsack Little Devil Ludlow	C continued Melody Pogo * Prairie * Ransom Rush Hour Spark * Summit Sutton Synth * Tinge Venue * Westwood * Wide Angle Zipline	D Eclat Weave * Menagerie	E Aegean Highland Katazome Sherman Shima	F Atelier Calais Cotton Velvet * Cornaro Icon Liberty Rivington * Soon Topography *	G Alter Ego Haze Kamani * Melange Petite Floral Ultrasuede	H Arno Magritte	I Cato Dynamic Knoll Velvet *† Piper Rutledge Tudor Vermeer	U Vicenza Volo	X Ducale Velour	Y Cervo Copenhagen Distressed Marissa Riva Saddle	V Acqua Andes Embossed Tipped España Velluto Pelle	W Alaska Amazon Antique Forte Satin Unapproved on frame Unbricates fabrics without topstitching Knoll Felt/Ivory K1207/1 not approved

Check with your KnollTextiles or Spinneybeck Representative for additions or changes.



Pierre Beucler and Jean-Christophe Poggioli

Architecture & Associés

Residential Lounge Seating

Designer(s):
Pierre Beucler and
Jean-Christophe Poggioli, 2012



description	seat h	arm h	w	d	h	type	textile fabric yds	leather sq ft	weight
AAR5 AA Small Ottoman, same upholstery, frame and cushions 	–	–	27 1/2"	24 1/2"	16"		2.2	40	–
AAR5 AA Small Ottoman, combination upholstery, frame and cushions	–	–	–	–	–	frame uph.	1.2	18	–
	–	–	–	–	–	upchg, cushions	1.3	22	–
AAR6 AA Medium Ottoman, same upholstery, frame and cushions 	–	–	31 1/8"	29 1/2"	16"		3.3	60	–
AAR6 AA Medium Ottoman, combination upholstery, frame and cushions	–	–	–	–	–	frame uph.	1.8	28	–
	–	–	–	–	–	upchg, cushions	2.3	32	–
AAR7 AA Large Ottoman, same upholstery, frame and cushions 	–	–	59"	29 1/2"	16 1/2"		4.5	74	–
AAR7 AA Large Ottoman, combination upholstery, frame and cushions	–	–	–	–	–	frame uph.	2.2	31	–
	–	–	–	–	–	upchg, cushions	2.7	43	–

pattern no.	grades A	COM B	C	D	E	F	G	H	I	COL U	V	W	X	Y
AAR5-(-)(-)	\$2,434.	\$2,489.	\$2,538.	\$2,592.	\$2,638.	\$2,670.	\$2,725.	\$2,830.	\$2,907.	\$3,491.	\$3,681.	\$4,067.	\$4,149.	\$4,241.
AAR5S-(-)(-)(-)	1,851.	1,880.	1,906.	1,938.	1,961.	1,979.	2,009.	2,068.	2,109.	2,281.	2,366.	2,541.	2,576.	2,619.
AAR5 cushions	734.	765.	796.	828.	855.	874.	906.	968.	1,014.	1,251.	1,356.	1,568.	1,613.	1,665.
AAR6-(-)(-)	2,565.	2,643.	2,718.	2,800.	2,867.	2,916.	2,999.	3,155.	3,273.	4,083.	4,368.	4,949.	5,069.	5,210.
AAR6S-(-)(-)(-)	1,927.	1,971.	2,011.	2,057.	2,094.	2,121.	2,165.	2,251.	2,315.	2,584.	2,720.	2,990.	3,045.	3,112.
AAR6 cushions	823.	878.	930.	988.	1,034.	1,068.	1,127.	1,238.	1,318.	1,540.	1,691.	2,000.	2,065.	2,139.
AAR7-(-)(-)	3,885.	3,993.	4,094.	4,207.	4,298.	4,365.	4,477.	4,692.	4,852.	5,698.	6,049.	6,764.	6,913.	7,087.
AAR7S-(-)(-)(-)	2,985.	3,037.	3,086.	3,142.	3,187.	3,220.	3,274.	3,380.	3,457.	3,694.	3,842.	4,142.	4,204.	4,276.
AAR7 cushions	1,059.	1,123.	1,184.	1,252.	1,308.	3,848.	1,414.	1,543.	1,639.	2,045.	2,248.	2,663.	2,751.	2,852.

Order Code	Ordering Information	Construction
<i>Example:</i> AAR5-C-SL69	<i>Leg finishes:</i> Chrome (suffix C) Copper (suffix CU)	<i>Frame:</i> Constructed in two formed plywood frames, back and seat, giving the pieces their architectural form. Frames are softened with highly resilient urethane foam wrapping.
AAR5 AA Small Ottoman	<i>Copper leg upcharge:</i> Copper leg finish is available at an upcharge of \$409 list. Use suffix CU to specify.	<i>Cushion fill:</i> "Residential" back cushion is 100% polyester fiber and the seat is a multi-density urethane foam.
C Chrome legs	<i>Upholstery/ COM information:</i> Prices shown includes fabric or leather upholstery. Contact your Knoll representative for colors. Only approved KnollTextiles and Spinneybeck leathers may be ordered.	<i>Legs:</i> Machined steel legs feature height adjustable feet for leveling.
SL69 Saddle, Seal Bay	<i>Customer's Own Material</i> is available pending approval. For approval requirements, processing instructions and ordering information please see page 18.	<i>Upholstery:</i> Interior loose cushions are available in either residential or contract versions. Contract cushions provide a tailored look for high use areas, while residential cushions convey a relaxed aesthetic. For units with combination upholstery, add list price of surround in appropriate grade with the list price of cushions to obtain total list price for item.
<i>Specify:</i> 1. Pattern number 2. Leg finish 3. Textile selection	<i>Maintenance:</i> See pages 28-29.	
<i>Specify with split upholstery:</i> 1. Pattern number 2. Leg finish 3. Textile selection, Surround 4. Textile selection, Cushions		



Approved KnollTextiles Grades/Fabrics				Spinneybeck Leather									
A Chance Common Ground Commuter Cloth Crossroad Delite Dristi Hourglass Mariner Overture Prep * Presto * Sonnet Trophy	B Argyle * Belize * Calypso Cameo Chroma Diva Ferry * Helios Journey Knoll Felt Knoll Hopsack Little Devil Ludlow	C continued Melody Pogo * Prairie * Ransom Rush Hour Spark * Summit Sutton Synth * Tinge Venue * Westwood * Wide Angle Zipline	D Eclat Weave * Menagerie	E Aegean Highland Katazome Sherman Shima	F Atelier Calais Cotton Velvet * Cornaro Icon Liberty Rivington * Soon Topography *	G Alter Ego Haze Kamani * Melange Petite Floral Ultrasuede	H Arno Magritte	I Cato Dynamic Knoll Velvet *† Piper * Rutledge Tudor Vermeer	U Vicenza Volo	X Ducale Velour	V Acqua Andes Embossed Tipped España Velluto Pelle	W Alaska Amazon Antique Forte Satin Unapproved on frame Unbricates fabrics without topstitching Knoll Felt/Ivory K1207/1 not approved	Y Cervo Copenhagen Distressed Marissa Riva Saddle

Check with your KnollTextiles or Spinneybeck Representative for additions or changes.

Cini Boeri Lounge Collection

Designer(s):
Cini Boeri, 2008

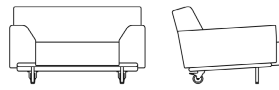
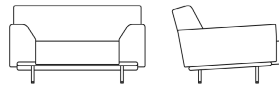
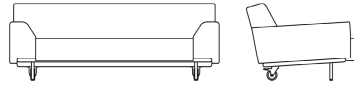
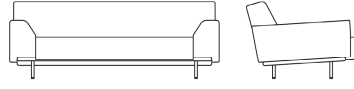

description	seat h	arm h	w	d	h	textile fabric yds.	req. leather sq. ft.	weight
CB1-C Lounge chair 	16 3/8"	22 3/16"	53 3/8"	43 3/8"	30 7/16"	6.2	145	113 lbs.
CB1-L Lounge chair with four standard legs 	16 3/8"	22 3/16"	53 3/8"	43 3/8"	30 7/16"	6.2	145	113 lbs.
CB2-C Sofa 	16 3/8"	22 3/16"	83"	43 3/8"	30 7/16"	7.8	200	142 lbs.
CB2-L Sofa with four standard legs 	16 3/8"	22 3/16"	83"	43 3/8"	30 7/16"	7.8	200	142 lbs.
CB3 Ottoman 			33"	33"	13 1/2"	3.6	50	50 lbs.

Order Code

Example:	CB2-L-K1152/1
CB2	Cini Boeri sofa
L	Four standard legs
K1152/1	Stirling, Gable

Specify:

1. Pattern number
2. Leg selection
3. Textile selection

Ordering Information

Upholstery/COM information:
Prices shown include fabric or leather upholstery. Contact your Knoll representative for colors. Only approved KnollTextiles and Spinneybeck leathers may be ordered.

Customer's Own Material in textile applications is limited and no COL leather applications are approved.
For approval requirements, processing instructions and ordering information, please see page 18.

Pillow:
Throw pillows for the Cini Boeri Lounge Collection are available in two sizes. Pillows are composed of recycled polyester. Since pillow is not fitted it is available in fabric only.

Maintenance:
See pages 28-29.

Note:
The Cini Boeri Lounge Collection is Greenguard certified.

Construction

Frame:
Formed steel tubing with powder coat finish. Finish color is Dark Grey paint (113).

Legs:
Available with four legs or a combination of legs and casters. Fixed rear locking casters are standard on Lounge Chair and Sofa. Swivel casters on ottoman do not lock.

Seat Cushion:
Seat cushion is made of highly-resilient polyurethane open-cell Cal 117 foam. Cushion is not reversible.

Upholstery:
Textile application must be railroaded. Textile applications are standard with single needle top stitch. Leather applications are standard with double needle top stitch. Please note that ottoman stitch detail is applicable to top seams only; side seams for both textile and leather are single blind seams.

pattern no.	grades A	COM B	C	D	E	F	G	H	I	COL U	V	W	X	Y
CB1-C	\$8,005.	\$8,178.	\$8,365.	\$8,556.	\$8,718.	\$8,826.	\$9,021.	\$9,383.	\$9,654.	\$12,703.	\$13,665.	\$15,388.	\$15,773.	\$16,156.
CB1-L	8,005.	8,178.	8,365.	8,556.	8,718.	8,826.	9,021.	9,383.	9,654.	12,703.	13,665.	15,388.	15,773.	16,156.
CB2-C	10,315.	10,552.	10,811.	11,069.	11,292.	11,439.	11,709.	12,205.	12,576.	16,933.	18,257.	20,640.	21,169.	21,699.
CB2-L	10,315.	10,552.	10,811.	11,069.	11,292.	11,439.	11,709.	12,205.	12,576.	16,933.	18,257.	20,640.	21,169.	21,699.
CB3-()	2,884.	2,984.	3,094.	3,203.	3,298.	3,360.	3,476.	3,683.	3,841.	3,943.	4,242.	4,778.	4,897.	5,015.

Approved KnollTextiles Grades/Fabrics

A Alignment * Beacon Bocce Cat's Cradle * Chance Common Ground Commuter Cloth Crossroad Delite Dristi Heavy Metal * Hourglass Mariner Monarch * Overture Prep * Presto * Sonnet Trophy Uni-Form	B continued Little Devil Ludlow Melody Mini Stitch * Nonchalant CR * Paradigm * Pogo * Prairie Prim ** Radiance Ransom Roam * Rush Hour Spark * Spree * Summit Sutton Synth Tabloid ** Tinge Utmost ** Venue * Westwood Zipline	C continued Dahlia CR Decade * Durand ** Earthwork # Echo * Empire Stripe * Emmesh * Entourage Essence Fable CR * Fibra * Greenwich * Hudson * Kaleidoscope * Kora CR * Lagos Lore CR * Metro * Milestone ** Moto CR * Palisade Panache CR * Versa * Quark * Roundtrip ** Sahara Spectator ** Spot On Star Struck * Stepping Stones Swing Tight Rope ** Tilden Tower Grid **	C continued Treble CR * Zari CR *	D Compass CR Coterie * Eclat Weave * Hologram * Island ** Kabuki ** Masquerade * Menagerie Origins * Woodland ** Zoom *	E Aegean Highland Ikat Stripe * Katazome Kimono * Mamba * Marquee * Meroe ** Sherman Shima Tryst * Whip	F Atelier Biscayne * Calais Cotton Velvet * Cornaro Glider * Icon Intrigue * Liberty ** Mod Plaid * Rivington * Soon Topography * Totem *	G Alter Ego Gibson * Haze Melange Modern Tweed Petite Floral Serendipity * Spencer * Ultrasuede # Utrillo **	H Arno Constance * Firefly ** Magritte Byron ** Cato Diamond Days Dynamic Jaipur ** Knoll Velvet Olema Piper Rutledge Sandis * Tudor Vermeer Zimba	I Byron ** Cato Diamond Days Dynamic Jaipur ** Knoll Velvet Olema Piper Rutledge Sandis * Tudor Vermeer Zimba	U Vicenza Volo	V Acqua Andes España Embossed Tipped Hand Tipped Velluto Pelle	W Alaska Amazon Antique Derby Forte Lucente Sabrina Umbria * Approved for CB3 ottoman, CBP1 and CBP2 throw pillows only. ** Approved for CBP1 and CBP2 throw pillows only.	X Ducale Ducale Velour	Y Cervo Copenhagen Distressed Marissa Riva Saddle
--	---	--	---	---	--	--	---	--	---	-----------------------------	---	---	-------------------------------------	--

Spinneybeck Leather



Check with your KnollTextiles or Spinneybeck Representative for changes or additions.

Cini Boeri

Lounge Collection

Designer(s):
Cini Boeri, 2008



description	seat h	arm h	w	d	h	textile fabric yds.	req. leather sq. ft.	weight
CBP1 Large throw pillow 			31"		24"	2	n/a	
CBP2 Small throw pillow 			24"		18"	1.6	n/a	

pattern no.	grades A	COM B	C	D	E	F	G	H	I	COL U	V	W	X	Y
CBP1-()	\$503.	\$556.	\$609.	\$662.	\$709.	\$742.	\$799.	\$905.	\$983.					
CBP2-()	432.	479.	535.	592.	639.	669.	726.	829.	909.					

Order Code

Example:	CB2-L-K1152/1
CB2	Cini Boeri sofa
L	Four standard legs
K1152/1	Stirling, Gable

Specify:

1. Pattern number
2. Leg selection
3. Textile selection

Ordering Information

Upholstery/COM information:
Prices shown include fabric or leather upholstery. Contact your Knoll representative for colors. Only approved KnollTextiles and Spinneybeck leathers may be ordered.

Customer's Own Material in textile applications is limited and no COL leather applications are approved.
For approval requirements, processing instructions and ordering information, please see page 18.

Pillow:
Throw pillows for the Cini Boeri Lounge Collection are available in two sizes. Pillows are composed of of recycled polyester. Since pillow is not fitted it is available in fabric only.

Maintenance:
See pages 28-29.

Note:
The Cini Boeri Lounge Collection is Greenguard certified.

Construction

Frame:
Formed steel tubing with powder coat finish. Finish color is Dark Grey paint (113).

Legs:
Available with four legs or a combination of legs and casters. Fixed rear locking casters are standard on Lounge Chair and Sofa. Swivel casters on ottoman do not lock.

Seat Cushion:
Seat cushion is made of highly-resilient polyurethane open-cell Cal 117 foam. Cushion is not reversible.

Upholstery:
Textile application must be railroaded. Textile applications are standard with single needle top stitch. Leather applications are standard with double needle top stitch. Please note that ottoman stitch detail is applicable to top seams only; side seams for both textile and leather are single blind seams.

Approved KnollTextiles Grades/Fabrics

A Alignment * Beacon Bocce Cat's Cradle * Chance Common Ground Commuter Cloth Crossroad Delite Dristi Heavy Metal * Hourglass Mariner Monarch * Overture Prep * Presto * Sonnet Trophy Uni-Form	B continued Little Devil Ludlow Melody Mini Stitch * Nonchalant CR * Paradigm * Pogo * Prairie Prim ** Radiance Ransom Roam * Rush Hour Spark * Spree * Summit Sutton Synth Tabloid ** Tinge Utmost ** Venue * Westwood Zipline	C continued Dahlia CR Decade * Durand ** Earthwork # Echo * Empire Stripe * Emesh * Entourage Essence Fable CR * Fibra * Greenwich * Hudson * Kaleidoscope * Kora CR * Lagos Lore CR * Metro * Milestone ** Moto CR * Palisade Panache CR * Versa * Quark * Roundtrip ** Sahara Spectator ** Spot On Star Struck * Stepping Stones Swing Tight Rope ** Tilden Tower Grid **	C continued Treble CR * Zari CR *	D Compass CR Coterie * Eclat Weave * Hologram * Island ** Kabuki ** Masquerade * Menagerie Origins * Woodland ** Zoom *	E Aegean Highland Ikat Stripe * Katazome Kimono * Mamba * Marquee * Meroe ** Sherman Shima Tryst * Whip	F Atelier Biscayne * Calais Cotton Velvet * Cornaro Glider * Icon Intrigue * Liberty ** Mod Plaid * Rivington * Soon Topography * Totem *	G Alter Ego Gibson * Haze Melange Modern Tweed Petite Floral Serendipity * Spencer * Ultrasuede # Utrillo **	H Arno Constance * Firefly ** Magritte Byron ** Cato Diamond Days Dynamic Jaipur ** Knoll Velvet Olema Piper Rutledge Sandis * Tudor Vermeer Zimba	I Byron ** Cato Diamond Days Dynamic Jaipur ** Knoll Velvet Olema Piper Rutledge Sandis * Tudor Vermeer Zimba	U Vicenza Volo Acqua Andes España Embossed Tipped Hand Tipped Velluto Pelle Alaska Amazon Antique Derby Forte Lucente Sabrina Umbria * Approved for CB3 ottoman, CBP1 and CBP2 throw pillows only. ** Approved for CBP1 and CBP2 throw pillows only.	V Acqua Andes España Embossed Tipped Hand Tipped Velluto Pelle	W Alaska Amazon Antique Derby Forte Lucente Sabrina Umbria * Approved for CB3 ottoman, CBP1 and CBP2 throw pillows only. ** Approved for CBP1 and CBP2 throw pillows only.	X Ducale Ducale Velour	Y Cervo Copenhagen Distressed Marissa Riva Saddle
--	---	---	---	---	--	--	---	--	---	---	---	---	-------------------------------------	--

Spinneybeck Leather

U Vicenza Volo	V Acqua Andes España Embossed Tipped Hand Tipped Velluto Pelle	W Alaska Amazon Antique Derby Forte Lucente Sabrina Umbria * Approved for CB3 ottoman, CBP1 and CBP2 throw pillows only. ** Approved for CBP1 and CBP2 throw pillows only.	X Ducale Ducale Velour	Y Cervo Copenhagen Distressed Marissa Riva Saddle
-----------------------------	---	---	-------------------------------------	--

Check with your KnollTextiles or Spinneybeck Representative for changes or additions.

Marcel Breuer

Cesca Chair

Designer(s):
Marcel Breuer, 1928



description	seat h	arm h	w	d	h	textile fabric yds.	req. leather sq. ft.	weight
50A-7 Arm chair, fully upholstered seat and back	17 3/4"	27"	23 1/2"	23 1/2"	31 1/2"	1.1	20	17 lbs.
50AR-7 Replacement seat, back and arms for 50A-7						1.1	20	
50A-5 Arm chair, wood frame, handwoven cane inset seat and back	17 3/4"	27"	23 1/2"	23 1/2"	31 1/2"			16 lbs.
50AR-5 Replacement seat, back, arms for 50A-5								

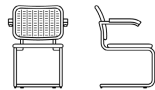
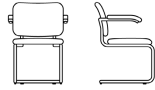

Order Code	Ordering Information	Construction
------------	----------------------	--------------

<i>Example:</i> 50A-5-BE	
50A-5	Cesca arm chair, cane seat
BE	Ebonized frame

Seat and back finishes:
Clear (suffix B)
Ebonized (suffix BE)

Cal 133 Fire Code ♣ :
The Cesca chair complies with California Technical Bulltin 133 with select KnollTextiles. Upcharge applies, see page 18.

Fully upholstered chairs:
Urethane foam over molded plywood seat and back. Solid hardwood arms. Arms are upholstered.

<i>Example:</i> 50C-2-K1106/8	
50C-2	Cesca armless chair, fully upholstered
K1106/8	Spencer, Apricot

Upholstery/COM information:
Prices shown include fabric or leather upholstery. Contact your Knoll representative for colors. Only approved KnollTextiles and Spinneybeck leathers may be ordered.

Note:
The KnollStudio logo and signature of Marcel Breuer are stamped into the base of the chair.

Cane inset chairs:
Hardwood beech seat/back frames and arms with natural clear lacquer or matte ebonized finish. Handwoven cane insets.

Note:
Cesca chairs are part of a collection. Please refer to the Wassily lounge chair and Laccio tables on pages 98 and 296.

Customer's Own Material is available pending approval. For approval requirements, processing instructions and ordering information please see page 18.

The Cesca Chair is Greenguard certified.

Frame:
1" diameter round steel tube with chrome-plated and polished finish.

- Specify:*
1. Pattern number
 2. Seat/back frame finish suffix

Maintenance:
See pages 28-29.

For fully upholstered specify:

1. Pattern number
2. Seat/back frame finish suffix
3. Textile selection

Glides:
Opaque plastic; snap-in place design. Glides shipped with each chair for optional in-field insertion.

Replacement seat baskets:
Cesca seat baskets can be replaced in the field by field services or a furniture repair specialist. Seat basket replacements do not ship with hardware and are not pre-drilled. They consist of seat and back for armless chairs; seat, back and arms for arm chair.

pattern no.	cane seat	grades A	COM B	C	D	E	F	G	H	I	COL U	V	W	X	Y
50A-7		\$1,511.	\$1,561.	\$1,608.	\$1,639.	\$1,671.	\$1,697.	\$1,727.	\$1,798.	\$1,939.	\$2,362.	\$2,526.	\$2,857.	\$2,943.	\$3,008.
50AR-7		884.	926.	970.	1,000.	1,031.	1,058.	1,083.	1,150.	1,283.	1,689.	1,848.	2,164.	2,243.	2,308.
50A-5-B		2,345.													
50A-5-BE		2,612.													
50AR-5-B		1,609.													
50AR-5-BE		1,873.													

Approved KnollTextiles Grades/Fabrics	Spinneybeck Leather
---------------------------------------	---------------------

A Alignment Beacon Bocce Chance Common Ground Commuter Cloth Crossroad Delite Dristi Hourlgass Mariner Overture Prep Presto Soliloquy Sonnet Trophy Uni-Form	B continued Helios Journey Keaton Knoll Felt Knoll Hopsack Little Devil Melody Paradigm Petal Pusher Pogo Prairie Prim Radiance Ransom Roam Rush Hour Spark Spree Summit Sutton Synth Tabloid Tinge Venue Versa Vinyl Westwood Wide Angle Yeni Zipline	C Atlas Axiom Baxter Charm Circa Classic Boucle Dahlia CR Decade Durand Earthwork Echo Empire.Stripe Enmesh Entourage Essence Fable CR Fibra Greenwich Hudson Hula Hoop Kora CR Lagos Magnolia Metro Moto CR Noble Palisade Panache CR Pullman Quark Roundtrip Sequin CR Sinclair Smart Spectator Spot On Star Struck Stepping Stones Swing	C continued Tight Rope Tilden Tower Grid Treble CR Wit Zari CR	D Coterie In Stitches Eclat Weave Hologram In The Loop Island Masquerade Menagerie Origins Woodand Zoom	E Aegean Cleo Demure Highland Ikat Stripe Juno Katazome Mamba Marquee Midpoint Nature Walk Sherman Shima Vatera Whip	F Atelier Biscayne Calais Cotton Velvet Cornaro Glider Icon Intrigue In Stitches Jasmine Liberty Mod Plaid Rivington Topography Totem Tweed Frieze	G Alter Ego Gibson Haze Kamani Melange Modern Tweed Petite Floral Serendipity Spencer♣ Straie Stripe Ultrasuede Utrillo	H Arno Bavaria Catwalk Constance Firefly Magritte Stretch Appeal	I Aswan Byron Cato Diamond Days Dynamic Ita Knoll Velvet Limani North Island Olema Piper Rutledge Tudor Vermeer Zimba	U Vicenza Volo	V Acqua Andes Embossed Tipped España Velluto Pelle	W Alaska Amazon Antique Derby Forte Lucente Sabrina Umbria	X Ducale Velour	Y Cervo Copenhagen Distressed Gemma Lucca Marissa Riva
---	---	---	---	---	--	---	--	--	---	-----------------------------	--	---	---------------------------	--

♣ Approved for Cal 133 upholstery

Check with your KnollTextiles or Spinneybeck Representative for changes or additions.

Marcel Breuer Cesca Chair

Designer(s):
Marcel Breuer, 1928



description	seat h	arm h	w	d	h	textile fabric yds.	leather sq. ft.	weight
50C-1 Armless chair, wood frame handwoven cane inset seat and back	17 3/4"		18 1/2"	23 1/2"	31 1/2"			11 lbs.
50CR-1 Replacement seat and back for 50C-1								
50C-2 Armless chair, fully upholstered seat and back	17 3/4"		18 1/2"	23 1/2"	31 1/2"	1.1	20	14 lbs.
50CR-2 Replacement seat, back and arms for 50C-2						1.1	20	

pattern no.	cane seat	grades A	COM B	C	D	E	F	G	H	I	COL U	V	W	X	Y
50C-1-BE	\$2,412.														
50C-1-B	2,150.														
50CR-1-B	1,407.														
50CR-1-BE	1,675.														
50C-2		1,211.	1,259.	1,304.	1,334.	1,368.	1,392.	1,424.	1,499.	1,633.	2,060.	2,220.	2,554.	2,638.	2,705.
50CR-2		595.	639.	679.	711.	740.	766.	795.	862.	995.	1,400.	1,556.	1,872.	1,952.	2,019.

Order Code	Ordering Information	Construction
<i>Example:</i> 50A-5-BE	<p><i>Seat and back finishes:</i> Clear (suffix B) Ebonized (suffix BE)</p> <p><i>Upholstery/COM information:</i> Prices shown include fabric or leather upholstery. Contact your Knoll representative for colors. Only approved KnollTextiles and Spinneybeck leathers may be ordered.</p> <p>Customer's Own Material is available pending approval. For approval requirements, processing instructions and ordering information please see page 18.</p>	<p><i>Cal 133 Fire Code</i> ♣ : The Cesca chair complies with California Technical Bulletin 133 with select KnollTextiles. Upcharge applies, see page 18.</p> <p><i>Note:</i> The KnollStudio logo and signature of Marcel Breuer are stamped into the base of the chair.</p> <p><i>Maintenance:</i> See pages 28-29.</p>
50A-5 Cesca arm chair, cane seat		
BE Ebonized frame		
<i>Example:</i> 50C-2-K1106/8	<p>The Cesca Chair is Greenguard certified.</p>	<p><i>Fully upholstered chairs:</i> Urethane foam over molded plywood seat and back. Solid hardwood arms. Arms are upholstered.</p> <p><i>Cane inset chairs:</i> Hardwood beech seat/back frames and arms with natural clear lacquer or matte ebonized finish. Handwoven cane insets.</p> <p><i>Frame:</i> 1" diameter round steel tube with chrome-plated and polished finish.</p> <p><i>Glides:</i> Opaque plastic; snap-in place design. Glides shipped with each chair for optional in-field insertion.</p> <p><i>Replacement seat baskets:</i> Cesca seat baskets can be replaced in the field by field services or a furniture repair specialist. Seat basket replacements do not ship with hardware and are not pre-drilled. They consist of seat and back for armless chairs; seat, back and arms for arm chair.</p>
50C-2 Cesca armless chair, fully upholstered		
K1106/8 Spencer, Apricot		
<p>Note: Cesca chairs are part of a collection. Please refer to the Wassily lounge chair and Laccio tables on pages 98 and 296.</p> <p>Specify:</p> <ol style="list-style-type: none"> 1. Pattern number 2. Seat/back frame finish suffix <p>For fully upholstered specify:</p> <ol style="list-style-type: none"> 1. Pattern number 2. Seat/back frame finish suffix 3. Textile selection 		

Approved KnollTextiles Grades/Fabrics				Spinneybeck Leather			
A Alignment Beacon Bocce Chance Common Ground Commuter Cloth Crossroad Delite Dristi Hourlgass Mariner Overture Prep Presto Soliloquy Sonnet Trophy Uni-Form	B continued Helios Journey Keaton Knoll Felt Knoll Hopsack Little Devil Melody Paradigm Petal Pusher Pogo Prairie Prim Radiance Ransom Roam Rush Hour Spark Spree Summit Sutton Synth Tabloid Tinge Venue Versa Vinyl Westwood Wide Angle Yeni Zipline	C Atlas Axiom Baxter Charm Circa Classic Boucle Dahlia CR Decade Durand Earthwork Echo Empire.Stripe Enmesh Entourage Essense Fable CR Fibra Greenwich Hudson Hula Hoop Kora CR Lagos Magnolia Metro Moto CR Noble Palisade Panache CR Pullman Quark Roundtrip Sequin CR Sinclair Smart Spectator Spot On Star Struck Stepping Stones Swing	C continued Tight Rope Tilden Tower Grid Treble CR Wit Zari CR D Coterie In Stitches Eclat Weave Hologram In The Loop Island Masquerade Menagerie Origins Woodland Zoom E Aegean Cleo Demure Highland Ikat Stripe Juno Katazome Mamba Marquee Midpoint Nature Walk Sherman Shima Vatera Whip	F Atelier Biscayne Calais Cotton Velvet Cornaro Glider Icon Intrigue In Stitches Jasmine Liberty Mod Plaid Rivington Topography Totem Tweed Frieze G Alter Ego Gibson Haze Kamani Melange Modern Tweed Petite Floral Serendipity Spencer♣ Straie Stripe Ultrasuede Utrillo	H Arno Bavaria Catwalk Constance Firefly Magritte Stretch Appeal I Aswan Byron Cato Diamond Days Dynamic Ita Knoll Velvet Limani North Island Olema Piper Rutledge Tudor Vermeer Zimba	U Vicenza Volo V Acqua Andes Embossed Tipped España Velluto Pelle W Alaska Amazon Antique Derby Forte Lucente Sabrina Umbria	X Ducale Velour Y Cervo Copenhagen Distressed Gemma Lucca Marissa Riva ♣ Approved for Cal 133 upholstery <i>Check with your KnollTextiles or Spinneybeck Representative for changes or additions.</i>

Marcel Breuer Wassily Chair

description	seat h	arm h	w	d	h	weight
50L Wassily chair	16½"	23"	31"	27"	28¾"	25 lbs.

Designer(s):
Marcel Breuer, 1925

Award(s):
The Museum of Modern Art, New York, USA, 1968; Recognition as "Piece of Art," W. Germany, 1982

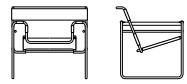

pattern no.

50L-()

\$3,934.

Order Code

<i>Example:</i>	50L-3COLHH
50L	Wassily chair
3COLHH	Haired Hide, Tri-Colored

Note:
The Wassily Chair is part of a collection. Please refer to Cesca side chairs and Laccio tables on pages 94 and 296.

Specify:
1. Pattern number
2. Sling material and color selection

Ordering Information

Spinneybeck Belting Leather:

- Black (suffix BLBLCK)
- Brown (suffix BL1923)
- Burnt Orange (suffix BL1907)
- Chocolate (suffix BL1902)
- Cognac (suffix BL1904)
- Cream (suffix BL1919)
- Dark Mustard (suffix BL1903)
- Dark Salmon (suffix BL1906)
- Deep Green (suffix BL1911)
- Deep Purple (suffix BL1913)
- Eggplant (suffix BL1926)
- Fudge (suffix BL1901)
- Gun Metal (suffix BL1917)
- Key Lime (suffix BL1910)
- Khaki (suffix BL1922)
- Lemon Meringue (suffix BL1909)
- Light Grey (suffix BL1916)
- Medium Grey (suffix BL1918)
- Putty (suffix BL1920)
- Simply Red (suffix BL1905)
- Smoke (suffix BL1915)
- Sunshine (suffix BL1908)
- Taupe (suffix BL1921)
- Umber (suffix BL1925)
- Warm Beige (suffix BL1924)
- White (suffix BL1914)

Cowhide leather colors:

- Black (suffix L80)
- Light Brown (suffix L82)
- White Beige (suffix L84)

Haired Hide:

- Black (suffix BLCKHH)
- Black and White (suffix BKWHHH)
- Chestnut (suffix OA12HH)
- Coffee (suffix OA18HH)
- Gold (suffix OCP5HH)
- Mahogany (suffix OA19HH)
- Tan (suffix OCP3HH)
- Tri-Color (suffix 3COLHH)

Upholstery note:

No Customer's Own Materials can be used.

Replacement slings:

Knoll does not recommend replacement slings. This procedure requires the chair to be disassembled and rebuilt, a complex and time consuming process.

KnollStudio 20-Day Program:

The Wassily Chair is available on the KnollStudio 20-Day program in Black and Simply Red. Spinneybeck belting leather. For specific information, consult pages 30-33.

Construction

Cal 133 Fire Code

The Wassily chair complies with California Technical Bulltin 133, see page 18.

Maintenance:
See pages 28-29.

Note:
The KnollStudio logo and signature of Marcel Breuer is stamped into the base of the chair.

The Wassily Chair is Greenguard certified.

Please ask your Spinneybeck Representative for samples of the belting leather and haired hide.

Frame:

Tubular steel with a polished chrome finish

Upholstery:

Cowhide Slings:
Thick cowhide leather slings in three colors. Edges dyed to match for Black and Light Brown colors. White Beige will have edges matching Light Brown cowhide color.

Belting Leather:

Highly durable Spinneybeck belting leather in twenty seven colors. Belting leather edges will always match specified color.





Haired Hide:

Spinneybeck haired hide in eight colors. Haired Hide is a natural material, markings are one-of-a-kind and will vary from piece to piece.

Glides:

Four, molded clear plastic glides with twin-pin snap-in construction included with each chair.

Don Chadwick Spark® Series

	description	seat h	w	d	h	textile fabric yds.	weight	arm h
<i>Designer(s):</i> Don Chadwick, 2009	4-C-SD-N Spark stacking side chair	18"	20½"	22"	31"	0.75	10 lbs.	
<i>Award(s):</i> Editors' Choice Award, Best of NeoCon, June 2009, USA GOOD DESIGN Award, Chicago Athenaeum, 2009, USA								
	4-C-SD-S Spark stacking side chair, with seat pad	18"	20½"	22"	31"	0.75	10 lbs.	
								
	4SDSEAT Seat pad replacement for 4-C-SD-S							
	4DOLLY Spark stacking dolly		25"	43"	30¼"		19 lbs.	
								
	4GA Spark ganging mechanism for side chair							
								



Order Code	Ordering Information	Construction
<i>Example:</i> 4-C-SD-S-04-K1000/11	<i>Maintenance:</i> See pages 28-29.	<i>Frame:</i> Integrally colored, textured, glass reinforced polypropylene; approved for indoor and out door use.
4-C-SD Spark stacking side chair	<i>Cal 133 Fire Code</i> ▲: The Spark stacking side and lounge chair complies with the Cal 133 fire code standard if upholstered in Cal 133 approved upholstery. Unupholstered chairs are not Cal 133 approved. Specify suffix -C at end of pattern number and suffix -133 at end of textile selection. Upcharge applies, see page 19.	<i>Seat Pad:</i> Molded highly-resilient polyurethane foam with textile cover and steel fasteners; approved for indoor use only.
S Seat pad	<i>KnollStudio 20-Day Program:</i> Spark side and lounge chairs with no upholstery are available on the 20-day program in all finishes. For specific ordering information consult pages 30-30.	<i>Stacking:</i> Spark side and lounge chairs stack up to 6 units high on the floor and 10 units high on the Spark dolly, which can accommodate the side or lounge chair. The dolly stacked with 10 side chairs measures 54" high and with 10 lounge chairs measures 53" high.
04 Light Grey	<i>Outdoor use:</i> With proper care and preventative maintenance, the Spark Series is appropriate for outdoor environments.	<i>Dolly:</i> Tubular metal frame with textured powder coat finish, four handles made of black thermoplastic elastomer (TPE) that act as bumpers to cushion the chairs, and four locking casters. Not appropriate for outdoor storage.
K1000/11 Presto, Navy Blue	<i>Recycled Content:</i> The Recycled Black color of both the non-upholstered side chair and the non-upholstered lounge chair contain 40% post-industrial recycled content. Recycled content percentages for the Recycled Black chairs with seat pads will vary depending on the fabric used. All other finishes do not contain recycled content.	

- Specify:*
1. Pattern number
 2. Finish selection
 3. Cal 133 Fire Code option
 4. Textile selection

- Finishes:*
- Blue (suffix 02)
 - Citron (suffix 03)
 - Dark Grey (suffix 05)
 - Light Grey (suffix 04)
 - Recycled Black (suffix 06)
 - Red (suffix 01)

Note:
Spark colors Red, Blue and Citron coordinate with KnollStudio Maya Lin Stones in Warm Red, Blue and Chartreuse finishes.

pattern no.	unuphol.	grades A	COM B	C	D	E	F	G	H	I
4-C-SD-N 	\$297.									
4-C-SD-S- ()	0.	441.	461.	478.	494.	515.	529.	548.	588.	619.
4SDSEAT		190.	211.	229.	244.	265.	280.	297.	337.	370.
4DOLLY	426.									
4GA	7.									

Approved KnollTextiles Grades/Fabrics



Ganging Device:
Semi-translucent TPE. The Spark ganging device adjoins the Spark side chairs' back legs. Position the ganging device so the raised surface in the middle of the device faces toward the front of the chair. The angle of the device should mirror the angle of the chair's back legs.

A Alignment ▲ Cat's Cradle ▲ Chance Common Ground ▲ Commuter Cloth ▲ Crossroad Delite Dristi Hourglass Mariner Overture Prep ▲ Presto ▲ Sonnet Uni-Form	B Abacus ▲ Argyle Belize Bistro Calypso Cameo ▲ Chronicle Close Knit Diva Dovetail ▲ Fast Forward Ferry Gala II Grande Grandview Helios Holbrook Journey Keaton Knoll Felt ▲ Knoll Hopsack ▲ Little Devil	C continued Ludlow Melody Mini Stitch ▲ Paradigm Petal Pusher Prairie Prim Radiance Ransom ▲ Roam Rush Hour Spark ▲ Spree Summit Sutton Tabloid Tinge Venue Versa Westwood Zipline	C continued Enmesh ▲ Entourage ▲ Essence Fable CR Fibra Greenwich Hudson ▲ Hula Hoop Kaleidoscope CR Kaya CR Kora CR Lagos Legend CR Lore CR Metro Milestone Noble Palisade Panache CR Pullman Quark ▲ Roundtrip ▲ Sequin CR Sinclair Smart Spectator ▲ Spot On Star Struck Stepping Stones Swing Tilden Tight Rope Tower Grid Treble CR	C continued Wit Zari CR D Compass CR Coterie Eclat Weave Hologram Island Masquerede Menagerie Origins Woodland Zoom E Aegean Cleo Demure Highland Ikat Stripe Juno Katazome Kimono Mamba Marquee Meroc Midpoint Nature Walk Sherman Tryst Vatera Whip	F Atelier Biscayne Cornaro Glider Icon Intrigue In Stitches Liberty Mod Plaid Rivington Soon Topography G Alter Ego Andissa Gibson Haze	G continued Melange Modern Tweed Serendipity Straie Stripe Ultrasuede ▲ H Arno ▲ Catwalk Constance Firefly Gezelle Magritte Stretch Appeal I Aswan Diamond Days Dynamic Ita Olema Piper Rutledge Vermeer Zimba
---	--	--	---	---	--	--

▲ Approved for Cal 133 upholstery.

Check with your KnollTextiles or Spinneybeck Representative for changes or additions.

Don Chadwick Spark® Series

	description	seat h	w	d	h	textile fabric yds.	weight	arm h
<i>Designer(s):</i> Don Chadwick, 2009	4-C-LG-N Spark stacking lounge chair	17"	25 1/2"	25 1/2"	30 1/2"	0.80	14 lbs.	
<i>Award(s):</i> Editors' Choice Award, Best of NeoCon, June 2009, USA GOOD DESIGN Award, Chicago Athenaeum, 2009, USA								
	4-C-LG-S Spark stacking lounge chair, with seat pad	17"	25 1/2"	25 1/2"	30 1/2"	0.80	14 lbs.	
								
	4LGSEAT Seat pad replacement for 4-C-LG-S							



Order Code	Ordering Information	Construction
<i>Example:</i> 4-C-SD-S-04-K1000/11	<i>Maintenance:</i> See pages 28-29.	<i>Frame:</i> Integrally colored, textured, glass reinforced polypropylene; approved for indoor and out door use.
4-C-SD Spark stacking side chair	<i>Cal 133 Fire Code</i> †: The Spark stacking side and lounge chair complies with the Cal 133 fire code standard if upholstered in Cal 133 approved upholstery. Unupholstered chairs are not Cal 133 approved. Specify suffix -C at end of pattern number and suffix -133 at end of textile selection. Upcharge applies, see page 19.	<i>Seat Pad:</i> Molded highly-resilient polyurethane foam with textile cover and steel fasteners; approved for indoor use only.
S Seat pad	<i>KnollStudio 20-Day Program:</i> Spark side and lounge chairs with no upholstery are available on the 20-day program in all finishes. For specific ordering information consult pages 30-30.	<i>Stacking:</i> Spark side and lounge chairs stack up to 6 units high on the floor and 10 units high on the Spark dolly, which can accommodate the side or lounge chair. The dolly stacked with 10 side chairs measures 54" high and with 10 lounge chairs measures 53" high.
04 Light Grey	<i>Outdoor use:</i> With proper care and preventative maintenance, the Spark Series is appropriate for outdoor environments.	<i>Dolly:</i> Tubular metal frame with textured powder coat finish, four handles made of black thermoplastic elastomer (TPE) that act as bumpers to cushion the chairs, and four locking casters. Not appropriate for outdoor storage.
K1000/11 Presto, Navy Blue	<i>Recycled Content:</i> The Recycled Black color of both the non-upholstered side chair and the non-upholstered lounge chair contain 40% post-industrial recycled content. Recycled content percentages for the Recycled Black chairs with seat pads will vary depending on the fabric used. All other finishes do not contain recycled content.	
<i>Specify:</i> 1. Pattern number 2. Finish selection 3. Cal 133 Fire Code option 4. Textile selection		
<i>Finishes:</i> Blue (suffix 02) Citron (suffix 03) Dark Grey (suffix 05) Light Grey (suffix 04) Recycled Black (suffix 06) Red (suffix 01)		
<i>Note:</i> Spark colors Red, Blue and Citron coordinate with KnollStudio Maya Lin Stones in Warm Red, Blue and Chartreuse finishes.		

pattern no.	unuphol.	grades A	COM B	C	D	E	F	G	H	I
4-C-LG-N 	\$463.									
4-C-LG-S-()		604.	623.	643.	657.	679.	693.	712.	752.	784.
4LGSEAT		204.	223.	241.	257.	278.	292.	311.	352.	382.

Approved KnollTextiles Grades/Fabrics

<i>Ganging Device:</i> Semi-translucent TPE. The Spark ganging device adjoins the Spark side chairs' back legs. Position the ganging device so the raised surface in the middle of the device faces toward the front of the chair. The angle of the device should mirror the angle of the chair's back legs.	A Alignment † Cat's Cradle † Chance Common Ground † Commuter Cloth † Crossroad Delite Dristi Hourglass Mariner Overture Prep † Presto † Sonnet Uni-Form	B continued Ludlow Melody Mini Stitch † Paradigm Petal Pusher Prairie Prim Radiance Ransom † Roam Rush Hour Spark † Spree Summit Sutton Tabloid Tinge Venue Versa Westwood Zipline	C continued Enmesh † Entourage † Essence Fable CR Fibra Greenwich Hudson † Hula Hoop Kaleidoscope CR Kora CR Lagos Legend CR Lore CR Metro Milestone Noble Palisade Panache CR Pullman Quark † Roundtrip † Sequin CR Sinclair Smart Spectator † Spot On Star Struck Stepping Stones Swing Tight Rope Tilden Tower Grid Treble CR	C continued Wit Zari CR D Compass CR Coterie Eclat Weave Hologram Island Masquerede Menagerie Origins Woodland Zoom E Aegean Cleo Demure Highland Ikat Stripe Juno Katazome Kimono Mamba Marquee Meroe Midpoint Nature Walk Sherman Tryst Vatera Whip	F Atelier Biscayne Cornaro Glider Icon Intrigue In Stitches Liberty Mod Plaid Rivington Soon Topography G Alter Ego Andissa Gibson Haze	G continued Melange Modern Tweed Serendipity Straie Stripe Ultrasuede † H Arno † Catwalk Constance Firefly Gezelle Magritte Stretch Appeal I Aswan Diamond Days Dynamic Ita Olema Piper Rutledge Vermeer Zimba
---	--	--	--	---	--	--

† Approved for Cal 133 upholstery.

Check with your KnollTextiles or Spinneybeck Representative for changes or additions.



Jonathan Crinion

Crinion Chair

Designer(s):
Jonathan Crinion, 1999

Award(s):
FX International Interior Design Award, 1999



description	seat h	arm h	w	d	h	textile fabric yds.	req. leather sq. ft.	weight	finish
58A Arm chair, upholstered seat 	17 1/2"	26 1/2"	23 1/4"	19 1/2"	30 3/4"	0.7	13	18 lbs.	beech stains
	17 1/2"	26 1/2"	23 1/4"	19 1/2"	30 3/4"	0.7	13	17 lbs.	maple
58C Armless chair, upholstered seat 	17 1/2"		20 1/2"	19 1/2"	30 3/4"	0.7	13	16 lbs.	beech stains
	17 1/2"		20 1/2"	19 1/2"	30 3/4"	0.7	13	15 lbs.	maple
58A-R Seat pad replacement, for arm chair with upholstered seat 58A						0.7	13		
58C-R Seat pad replacement, for armless chair with upholstered seat 58C						0.7	13		

pattern no.	grades A	COM B	C	D	E	F	G	H	I	COL U	V	W	X	Y
58A-()	\$1,707.	\$1,740.	\$1,770.	\$1,804.	\$1,830.	\$1,851.	\$1,889.	\$1,949.	\$2,001.	\$2,165.	\$2,285.	\$2,530.	\$2,578.	\$2,638.
58A-(KC)	2,091.	2,123.	2,153.	2,187.	2,214.	2,236.	2,272.	2,332.	2,386.	2,549.	2,670.	2,914.	2,963.	3,021.
58C-()	1,454.	1,487.	1,518.	1,549.	1,583.	1,598.	1,631.	1,700.	1,746.	1,913.	2,031.	2,274.	2,326.	2,383.
58C-(KC)	1,731.	1,763.	1,794.	1,825.	1,858.	1,873.	1,906.	1,974.	2,023.	2,187.	2,307.	2,549.	2,603.	2,655.
58A-R-()	285.	318.	343.	376.	404.	418.	453.	515.	561.	714.	829.	1,060.	1,109.	1,164.
58C-R-()	285.	318.	343.	376.	404.	418.	453.	515.	561.	714.	829.	1,060.	1,109.	1,164.

Order Code

<i>Example:</i> 58A-BB-K715/3	Crinion arm chair
B323	Medium Walnut
K715/3	Abacus, Gold Coin

Specify:

1. Pattern number
2. Finish selection
3. Textile selection

Ordering Information

Clear Maple finish:
Maple (suffix KC)

Beech frame stains:
Beech (suffix B311)
Bronzed Cherry (suffix B312A)
Burnt Walnut (suffix B313)
Deep Red Mahogany (suffix B328)
Ebonized (suffix BE)
Light Cherry (suffix B315)
Medium Cherry (suffix B319)
Medium Red Mahogany (suffix BR)
Medium Walnut (suffix B323)
Natural Beech (suffix BN)
Warm Brown Walnut (suffix J)

Upholstery/COM information:
Prices shown include fabric or leather upholstery. Contact your Knoll representative for colors. Only approved KnollTextiles and Spinneybeck leathers may be ordered.

Customer's Own Material is available pending approval. For approval requirements, processing instructions and ordering information please see page 18.

KnollStudio wood finishes:
KnollStudio wood finishes complement a large variety of KnollStudio veneer and Knoll Office veneer finishes. To select correct complementary finish, please refer to KnollStudio Wood Finish Matrix on page 25. Complementary finishes are available at no upcharge. If no complementary standard finish is available, please refer to custom finish policy below.

Custom finishes:
To complement non-Knoll wood veneer or lumber finishes, a one-time, non-negotiable net upcharge of \$662 applies. Re-orders are at no upcharge.

Please contact your KnollStudio representative, dealer or Customer Service associate for complete custom finish information and Order Code. Minimum order quantity for any custom finish order: 4 chairs.

Cal 133 Fire Code:
Crinion Chairs with upholstered seat comply with the California Technical Bulletin 133 standard if upholstered in Cal 133 approved upholstery. Specify suffix -C at end of pattern number and suffix -133 at end of textile selection. Upcharge applies, see page 18.

Maintenance:
See pages 28-29.

Note:
The Crinion Chair is Greenguard certified.

Construction

Frame:
Clear Maple Chair: Select clear maple hardwood frame with maple plywood back panel in clear finish. Dowel, mortise and tenon construction. Arm supported by metal cross dowel.

Beech Chair: Select beech hardwood frame with plywood back panel in clear or stained finishes. Arm supported by metal cross dowel.





Seat pad:
Upholstered, high-density polyurethane foam seat pad on a plywood seat basket with Dymetrol® suspension. Seat pad reaches to the seat frame edge, surrounds arm.

Seat pad replacement:
Seat pad can be replaced in the field.

Finish:
Catalyzed lacquer protective coating. Hand-applied final wax coating.

High Traffic Areas:
When specifying armless chair in high use or high traffic areas, we recommend the use of a stretcher for added strength. Contact CPD or your KnollStudio sales representative for more information.

Approved KnollTextiles Grades/Fabrics

A Alignment  Beacon Bocce Chance Common Ground  Commuter Cloth  Crossroad Delite Heavy Metal Hourglass Mariner Monarch  Overture Prep  Presto  Soliloquy Sonnet Trophy Uni-Form	B Abacus  Argyle Backdrop Belize Bistro  Boundary  Calypso Cameo Chroma  Chronicle Close Knit Digital Tape Diva Dovetail  Fast Forward Ferry	C Atlas Axiom Baxter Charm Circa Classic Boucle Dahlia CR Decade Durand Earthwork  Echo Empire Stripe Emmesh  Entourage Essence Fable CR Greenwich Hudson Hula Hoop Kaleidoscope CR Kora CR Lagos Legend CR Lore CR Magnolia Metro Milestone Moto CR Noble Palisade Panache CR Pullman Quark Roundtrip Sequin CR Sinclair Smart Spot On Star Struck	C continued Stepping Stones Spectator Swing Tight Rope Tilden Tower Grid Treble CR Wit Zari CR	D Compass CR Coterie Hologram In The Loop Island Kabuki Masquerade Menagerie Origins Woodland Zoom	E Aegean Cleo Highland Ikat Stripe Juno Katazome Mamba Marquee Midpoint Nature Walk Sherman Shima Tryst Vatera Whip 	F Atelier Biscayne Calais Cotton Velvet Cornaro Glider Icon Intrigue In Stitches Liberty Mod Plaid Rivington Soon Topography Totem Tweed Frieze	G Alter Ego Arber Gibson Haze Kamani Melange Modern Tweed Petite Floral Serendipity Straie Stripe Ultrasuede  Utrillo	H Arno Bavaria Constance Magritte Stretch Appeal	I Aswan Byron Cato Cummings Diamond Days Dynamic Ita Jaipur Knoll Velvet Limani North Island Olema Piper Rutledge Tudor Vermeer Zimba	U Vicenza  Volo  V Acqua  Andes  Embossed Tipped España  Hand Tipped Velluto Pelle  W Alaska  Amazon  Antique  Forte  Lucente Sabrina  Umbria X Ducale  Ducale Velour 	Y Cervo Copenhagen  Distressed Gemma Lucca Marissa  Portofino Riva  Torello
---	--	---	--	--	---	--	---	--	---	---	--

Spinneybeck Leather

 Available for Cal 133 upholstery.

Check with your KnollTextiles or Spinneybeck Representative for changes or additions.

Joseph Paul D’Urso

Contract Lounge Seating

Designer(s):
Joseph Paul D’Urso, 2008

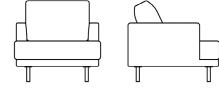

description	w	d	h	seat h	arm h	type	textile	leather	weight
							fabric yds.	sq ft	
2160 Contract Lounge chair, same upholstery, frame and cushions	34"	36 1/2"	30 1/2"	17 3/8"	22 3/8"		7.6	105	70 lbs.
2160 Contract Lounge chair, combination upholstery, frame and cushions	34"	36 1/2"	30 1/2"	17 3/8"	frame	4.6	60		
					upchg, cushions	3.2	50		

pattern no.	grades	COM	C	D	E	F	G	H	I	COL	U	V	W	X	Y
2160-C-()	\$4,370.	\$4,567.	\$4,750.	\$4,955.	\$5,119.	\$5,240.	\$5,443.	\$5,832.	\$6,119.	\$7,404.	\$7,940.	\$9,024.	\$9,252.	\$9,514.	
2160S-C-()-()	3,334.	3,484.	3,625.	3,780.	3,905.	4,000.	4,154.	4,452.	4,669.	5,313.	5,715.	6,532.	6,702.	6,900.	
upchg, cushions	1,429.	1,493.	1,554.	1,620.	1,674.	1,714.	1,779.	1,907.	2,001.	2,278.	2,450.	2,800.	2,871.	2,957.	

Order Code	Ordering Information	Construction
<i>Example:</i> 2160-C-H800/40	<i>Leg finishes:</i> Polished Chrome (suffix C)	<i>Frame:</i> Constructed of plywood with sinuous spring seat suspension and matrix back suspension. Standard lounge chair and small sofa depth is 36"; residential sofa is 40" deep.
2160	D’Urso Contract Lounge Collection, lounge chair	<i>Stitching:</i> Non-directional textiles with railroad application, single needle topstitch for arms, double needle topstitch for seat and back cushions; directional textiles, single needle topstitch for arms, double needle topstitch for seat and back cushions, single blind stitch for vertical seams of seat cushion, a vertical single blind center seam joins inside and outside back panels of the sofa; leather, single needle topstitch for arms, double needle topstitch for seat and back cushions, single blind stitch for vertical seams of seat cushion, a vertical double needle topstitch seam joins inside and outside back panels of sofa. Ottoman; all applications, double needle topstitch for horizontal cushion seams, single blind seam for vertical seams of seat cushion.
C	Polished Chrome legs	<i>Upholstery:</i> One seat and back cushion for the Lounge Chair, two seat and back cushions for the Small Sofa, one semi-attached cushion for Ottoman. For units with combination upholstery, add list price of surround in appropriate grade with the list price of cushions to obtain total list price for item.
H800/40	Cato, Orange	<i>Legs:</i> Seat cushions constructed of highly resilient polyurethane foam and polyester fiber, wrapped in polyester fiber batting. Back cushion constructed with a soft polyurethane foam core and polyester fiber fill. Side cushion constructed of 10/90 down with a down proof ticking. Leather cushions feature a perforated zipper breather panel.
<i>Example:</i> 2161-C-S-HT1502-K1206/6	<i>Upholstery/COM information:</i> Prices shown includes fabric or leather upholstery. Contact your Knoll representative for colors. Only approved KnollTextles and Spinneybeck leathers may be ordered.	<i>Maintenance:</i> See pages 28-29.
2161	D’Urso Contract Lounge Collection, small sofa	Railroad upholstery application is standard for all non-directional textiles. Please see 'Stitching' for seam details.
C	Polished Chrome legs	
S	Split upholstery	
HT1502	Surround in Hand Tipped, Mesa Verde	
K1206/6	Cushions in Knoll Hopsack, Gold	

Specify:

1. Pattern number
2. Leg finish
3. Textile selection

Specify with split upholstery:

1. Pattern number
2. Leg finish
3. Split upholstery option
4. Textile selection, Surround
5. Textile selection, Cushions

Approved KnollTextiles Grades/Fabrics							Spinneybeck Leather						
A Alignment ‡ Beacon Bocce Cat’s Cradle Common Ground Commuter Cloth ‡ Crossroad Delite Dristi Hourglass Mariner Monarch ‡ Overture Prep ‡ Presto ‡ Sonnet Trophy Uni-Form	B continued Melody Mini Stitch ‡ Paradigm Pogo Prairie Prim Radiance Ransom Rush Hour Spark ‡ Spree Summit Sutton Synth Tabloid Tinge Venue Versa Vinyl Westwood Wide Angle ‡ Zipline	C continued Echo Empire Stripe Enmesh ‡ Entourage Essence Fable CR Fibra Hudson Hula Hoop Kaleidoscope CR Kora CR Lagos Legend CR Lore CR Metro Palisade Panache CR Pullman Quark Roundtrip Sahara Sequin CR Spectator * Spot On Star Struck Stepping Stones Swing Tilden Wit Zari CR	D Compass CR Coterie Eclat Weave Hologram Island Kabuki Masquerade Menagerie Woodland Zoom	E Aegean Demure Highland Ikata Stripe Katazome Kimono Mamba Marquee Meroc Sherman Shima Tryst Whip	F Atelier Calais Cotton Velvet Cornaro Icon Intrigue In Stitches Liberty Mod Plaid Rivington Soon Topography Totem Tweed Frieze	G Alter Ego Gibson Haze Melange Modern Tweed Petite Floral Spencer Ultrasuede ‡	H Arno ‡ Constance Firefly Magritte	I Byron Cato Diamond Days Dynamic Knoll Velvet Piper Tudor Vermeer Zimba	U Vicenza ‡ Volo ‡	V Acqua ‡ Andes ‡ Embossed Tipped España ‡ Hand Tipped ‡ Velluto Pelle ‡	W Alaska ‡ Amazon ‡ Antique ‡ Derby ‡ Forte ‡ Lucente Sabrina ‡ Umbria * Approved for 2161P only.	X Ducale Ducale Velour ‡	Y Cervo Copenhagen ‡ Distressed ‡ Marissa ‡ Riva ‡ Saddle ‡

Check with your KnollTextiles or Spinneybeck Representative for additions or changes.

Joseph Paul D’Urso

Contract Lounge Seating

Designer(s):
Joseph Paul D’Urso, 2008



description	width	depth	height	seat h, max	arm h, max	type	textile fabric yards	leather sq ft	weight
2161 Contract Small Sofa, same upholstery, frame and cushions	74"	36 1/2"	30 1/2"	17 3/8"	22 3/8"		13.5	215	135 lbs.
2161 Contract Small Sofa, combination upholstery, frame and cushions	74"	36 1/2"	30 1/2"	17 3/8"		frame uph.	6.5	95	
						upchg, cushions	7	120	
2163 Contract Ottoman, same upholstery, frame and cushions	28 1/2"	28 1/2"	16"	16"			3.5	45	29 lbs.
2163 Contract Ottoman, combination upholstery, frame and cushions	28 1/2"	28 1/2"	16"	16"		frame uph.	1.4	15	
						upchg, cushions	2.8	30	
2161P Optional side cushion for small sofa	17"	3"	11"				1	n/a	5 lbs.

Order Code	Ordering Information	Construction
<i>Example:</i> 2160-C-H800/40	<i>Leg finishes:</i> Polished Chrome (suffix C)	<i>Frame:</i> Constructed of plywood with sinuous spring seat suspension and matrix back suspension. Standard lounge chair and small sofa depth is 36"; residential sofa is 40" deep.
2160	D’Urso Contract Lounge Collection, lounge chair	
C	Polished Chrome legs	
H800/40	Cato, Orange	
<i>Example:</i> 2161-C-S-HT1502-K1206/6	<i>Upholstery/COM information:</i> Prices shown includes fabric or leather upholstery. Contact your Knoll representative for colors. Only approved KnollTextles and Spinneybeck leathers may be ordered.	<i>Stitching:</i> Non-directional textiles with railroad application, single needle topstitch for arms, double needle topstitch for seat and back cushions; directional textiles, single needle topstitch for arms, double needle topstitch for seat and back cushions, single blind stitch for vertical seams of seat cushion, a vertical single blind center seam joins inside and outside back panels of the sofa; leather, single needle topstitch for arms, double needle topstitch for seat and back cushions, single blind stitch for vertical seams of seat cushion, a vertical double needle topstitch seam joins inside and outside back panels of sofa. Ottoman; all applications, double needle topstitch for horizontal cushion seams, single blind seam for vertical seams of seat cushion.
2161	D’Urso Contract Lounge Collection, small sofa	
C	Polished Chrome legs	
S	Split upholstery	
HT1502	Surround in Hand Tipped, Mesa Verde	
K1206/6	Cushions in Knoll Hopsack, Gold	
	<i>Maintenance:</i> See pages 28-29.	<i>Upholstery:</i> One seat and back cushion for the Lounge Chair, two seat and back cushions for the Small Sofa, one semi-attached cushion for Ottoman. For units with combination upholstery, add list price of surround in appropriate grade with the list price of cushions to obtain total list price for item.
		<i>Legs:</i> 6" steel leg, 1 1/4" diameter, available in polished chrome with black nylon glides.
		<i>Cushions:</i> Seat cushions constructed of highly resilient polyurethane foam and polyester fiber, wrapped in polyester fiber batting. Back cushion constructed with a soft polyurethane foam core and polyester fiber fill. Side cushion constructed of 10/90 down with a down proof ticking. Leather cushions feature a perforated zipper breather panel.

Specify:

1. Pattern number
2. Leg finish
3. Textile selection

Specify with split upholstery:

1. Pattern number
2. Leg finish
3. Split upholstery option
4. Textile selection, Surround
5. Textile selection, Cushions

pattern no.	grade A	COM B	C	D	E	F	G	H	I	COL U	V	W	X	Y
2161-C-()	\$6,898.	\$7,244.	\$7,572.	\$7,934.	\$8,230.	\$8,444.	\$8,805.	\$9,495.	\$10,005.	\$13,041.	\$14,135.	\$16,360.	\$16,823.	\$17,363.
2161S-C-()-()	5,263.	5,527.	5,778.	6,054.	6,281.	6,442.	6,717.	7,245.	7,633.	9,358.	10,142.	11,738.	12,071.	12,458.
upchg, cushions	2,256.	2,368.	2,475.	2,595.	2,690.	2,760.	2,879.	3,104.	3,272.	4,010.	4,347.	5,032.	5,175.	5,340.
2163-C-()	2,632.	2,739.	2,841.	2,954.	3,045.	3,113.	3,224.	3,439.	3,599.	4,086.	4,315.	4,781.	4,879.	4,992.
2163S-C-()-()	2,007.	2,091.	2,167.	2,253.	2,323.	2,376.	2,461.	2,625.	2,746.	2,932.	3,097.	3,431.	3,499.	3,581.
upchg, cushions	860.	895.	929.	966.	996.	1,018.	1,056.	1,126.	1,176.	1,256.	1,327.	1,471.	1,501.	1,536.
2161P-()	486.	512.	536.	563.	583.	600.	627.	678.	716.					

Approved KnollTextiles Grades/Fabrics						Spinneybeck Leather							
A Alignment † Beacon Bocce Cat’s Cradle Common Ground Commuter Cloth † Crossroad Delite Dristi Hourglass Mariner Monarch † Overture Prep † Presto † Sonnet Trophy Uni-Form	B continued Melody Mini Stitch † Paradigm Pogo Prairie Prim Radiance Ransom Rush Hour Spark † Spree Summit Sutton Synth Tabloid Tinge Venue Versa Vinyl Westwood Wide Angle † Zipline	C continued Echo Empire Stripe Enmesh † Entourage Essence Fable CR Fibra Hudson Hula Hoop Kaleidoscope CR Kora CR Lagos Legend CR Lore CR Metro Milestone Moto CR Palisade Panache CR Pullman Quark Roundtrip Sahara Sequin CR Spectator * Spot On Star Struck Stepping Stones Swing Tilden Wit Zari CR	D Compass CR Coterie Eclat Weave Hologram Island Kabuki Masquerade Menagerie Woodland Zoom	E Aegean Demure Highland Ikata Stripe Katazome Kimono Mamba Marquee Meroc Sherman Shima Tryst Whip	F Atelier Calais Cotton Velvet Cornaro Icon Intrigue In Stitches Liberty Mod Plaid Rivington Soon Topography Totem Tweed Frieze	G Alter Ego Gibson Haze Melange Modern Tweed Petite Floral Spencer Ultrasuede †	H Arno † Constance Firefly Magritte	I Byron Cato Diamond Days Dynamic Knoll Velvet Piper Tudor Vermeer Zimba	U Vicenza † Volo †	V Acqua † Andes † Embossed Tipped España † Hand Tipped † Velluto Pelle †	W Alaska † Amazon † Antique † Derby † Forte † Lucente Sabrina † Umbria * Approved for 2161P only.	X Ducale Ducale Velour †	Y Cervo Copenhagen † Distressed † Marissa † Riva † Saddle †

Check with your KnollTextiles or Spinneybeck Representative for additions or changes.

Joseph Paul D’Urso

Residential Lounge Seating

Designer(s):
Joseph Paul D’Urso, 2008



description	w	d	h	seat h	arm h	type	textile fabric yds.	leather sq ft.	weight
2160R Residential Lounge chair, same upholstery, frame and cushions	34"	36 1/2"	28 1/2"	15 3/8"	20 3/8"		7.6	105	67 lbs.
2160R Residential Lounge chair, combination upholstery, frame and cushions	34"	36 1/2"	28 1/2"	15 3/8"		frame uph.	4.6	60	
						upchg, cushions	3.2	50	

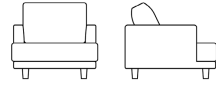

Order Code	Ordering Information	Construction
<i>Example:</i> 2160R-OE-K162/25	<i>Leg finishes:</i> Burnt Walnut on Oak (suffix 0313) Clear Oak (suffix OC) Ebonized on Oak (suffix OE) Polished Chrome (suffix C)	<i>Frame:</i> Constructed of plywood with sinuous spring seat suspension and matrix back suspension. Standard lounge chair and sofa depth is 36"; residential sofa is 40" deep.
2160R	D’Urso Residential Lounge Collection, lounge chair	<i>Upholstery:</i> One seat and back cushion for the Lounge Chair, two seat and back cushions for the Sofa, one semi-attached cushion for Ottoman. For units with combination upholstery, add list price of surround in appropriate grade with the list price of cushions to obtain total list price for item.
OE	Ebonized legs	<i>Stitching:</i> Non-directional textiles with railroad application, single needle topstitch for arms, double needle topstitch for seat and back cushions; directional textiles, single needle topstitch for arms, double needle topstitch for seat and back cushions, single blind stitch for vertical seams of seat cushion, a vertical single blind center seam joins inside and outside back panels of the sofa; leather, single needle topstitch for arms, double needle topstitch for seat and back cushions, single blind stitch for vertical seams of seat cushion, a vertical double needle topstitch seam joins inside and outside back panels of sofa. Ottoman; all applications, double needle topstitch for horizontal cushion seams, single blind seam for vertical seams of seat cushion.
K162/25	Classic Boucle, Aegean	<i>Legs:</i> 4" steel leg, 1 1/4" diameter, available in polished chrome with black nylon glides, or 4" turned solid oak leg available in natural oak, medium walnut on oak and ebonized oak with white nylon glides.
<i>Example:</i> 21623R-0313-S-K1152/8-K1024/3	<i>Upholstery/COM information:</i> Prices shown includes fabric or leather representative for colors. Only approved KnollTextiles and Spinneybeck leathers may be ordered.	
2163R	D’Urso Residential Lounge Collection, ottoman	
0313	Burnt Walnut legs	
S	Split upholstery	
K1152/8	Surround in Stirling, Cobble	Railroad upholstery application is standard for all non-directional textiles. Please see 'Stitching' for seam details.
K1024/3	Cushions in Coco, Ciel	
<i>Specify:</i>	<i>Maintenance:</i> See pages 28-29.	
1. Pattern number		
2. Leg finish		
3. Textile selection		
<i>Specify with split upholstery:</i>		
1. Pattern number		
2. Leg finish		
3. Split upholstery option		
4. Textile selection, Surround		
5. Textile selection, Cushions		
		Leather cushions feature a perforated zipper breather panel.

pattern no.	grades	COM	C	D	E	F	G	H	I	COL	U	V	W	X	Y
2160R-(-)-(-)	\$4,370.	\$4,567.	\$4,750.	\$4,955.	\$5,119.	\$5,240.	\$5,443.	\$5,832.	\$6,119.	\$7,404.	\$7,940.	\$9,024.	\$9,252.	\$9,514.	
2160RS-(-)-(-)	3,334.	3,484.	3,625.	3,780.	3,905.	4,000.	4,154.	4,452.	4,669.	5,313.	5,715.	6,532.	6,702.	6,900.	
upchg, cushions	1,429.	1,493.	1,554.	1,620.	1,674.	1,714.	1,779.	1,907.	2,001.	2,278.	2,450.	2,800.	2,871.	2,957.	

Approved KnollTextiles Grades/Fabrics						Spinneybeck Leather							
A Alignment ‡ Beacon Bocce Cat’s Cradle Common Ground Commuter Cloth ‡ Crossroad Delite Dristi Hourglass Mariner Monarch ‡ Overture Prep ‡ Presto ‡ Sonnet Trophy Uni-Form	B continued Melody Mini Stitch ‡ Paradigm Pogo Prairie Prim Radiance Ransom Rush Hour Spark ‡ Spree Summit Sutton Synth Tabloid Tinge Venue Versa Vinyl Westwood Wide Angle ‡ Zipline	C continued Echo Empire Stripe Enmesh ‡ Entourage Essence Fable CR Fibra Hudson Hula Hoop Kaleidoscope CR Kora CR Lagos Legend CR Lore CR Metro Milestone Moto CR Palisade Panache CR Pullman Quark Roundtrip Sahara Sequin CR Spectator * Spot On Star Struck Stepping Stones Swing Tilden Wit Zari CR	D Compass CR Coterie Eclat Weave Hologram Island Kabuki Masquerade Menagerie Woodland Zoom	E Aegean Demure Highland Ikat Stripe Katazome Kimono Mamba Marquee Meroe Sherman Shima Tryst Whip	F Atelier Calais Cotton Velvet Cornaro Icon Intrigue In Stitches Liberty Mod Plaid Rivington Soon Topography Totem Tweed Frieze	G Alter Ego Gibson Haze Melange Modern Tweed Petite Floral Spencer Ultrasuede ‡	H Arno ‡ Constance Firefly Magritte	I Byron Cato Diamond Days Dynamic Knoll Velvet Piper Tudor Vermeer Zimba	U Vicenza ‡ Volo ‡	V Acqua ‡ Andes ‡ Embossed Tipped España ‡ Hand Tipped ‡ Velluto Pelle ‡	W Alaska ‡ Amazon ‡ Antique ‡ Derby ‡ Forte ‡ Lucente Sabrina ‡ Umbria * Approved for 2162P only.	X Ducale Ducale Velour ‡	Y Cervo Copenhagen ‡ Distressed ‡ Marissa ‡ Riva ‡ Saddle ‡
<i>Check with your KnollTextiles or Spinneybeck Representative for additions or changes.</i>													

Joseph Paul D’Urso

Residential Lounge Seating

Designer(s):
Joseph Paul D’Urso, 2008



description	width	depth	height	seat h, max	arm h, max	type	textile fabric yards	leather sq ft	weight
2162R Residential Sofa, same upholstery, frame and cushions	90"	40 1/2"	28 1/2"	15 3/8"	20 3/8"		14	250	151 lbs.
2162R Residential Sofa, combination upholstery, frame and cushions	90"	40 1/2"	28 1/2"	15 3/8"	frame uph.	upchg, cushions	6.7	110	
							7.7	145	
2163R Residential Ottoman, same upholstery, frame and cushions	28 1/2"	28 1/2"	14"	14"			3.5	45	26 lbs.
2163R Residential Ottoman, combination upholstery, frame and cushions	28 1/2"	28 1/2"	14"	14"	frame uph.	upchg, cushions	1.4	15	
							2.8	30	
2162P Optional side cushion for residential sofa	21"	5"	11"				1	n/a	6 lbs.

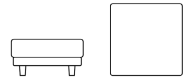
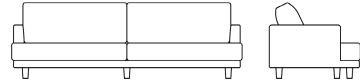

Order Code	Ordering Information	Construction
<i>Example:</i> 2160R-OE-K162/25	<i>Leg finishes:</i> Burnt Walnut on Oak (suffix 0313) Clear Oak (suffix OC) Ebonized on Oak (suffix OE) Polished Chrome (suffix C)	<i>Frame:</i> Constructed of plywood with sinuous spring seat suspension and matrix back suspension. Standard lounge chair and sofa depth is 36"; residential sofa is 40" deep.
2160R	D’Urso Residential Lounge Collection, lounge chair	<i>Upholstery:</i> One seat and back cushion for the Lounge Chair, two seat and back cushions for the Sofa, one semi-attached cushion for Ottoman. For units with combination upholstery, add list price of surround in appropriate grade with the list price of cushions to obtain total list price for item.
OE	Ebonized legs	<i>Stitching:</i> Non-directional textiles with railroad application, single needle topstitch for arms, double needle topstitch for seat and back cushions; directional textiles, single needle topstitch for arms, double needle topstitch for seat and back cushions, single blind stitch for vertical seams of seat cushion, a vertical single blind center seam joins inside and outside back panels of the sofa; leather, single needle topstitch for arms, double needle topstitch for seat and back cushions, single blind stitch for vertical seams of seat cushion, a vertical double needle topstitch seam joins inside and outside back panels of sofa. Ottoman; all applications, double needle topstitch for horizontal cushion seams, single blind seam for vertical seams of seat cushion.
K162/25	Classic Boucle, Aegean	<i>Legs:</i> 4" steel leg, 1 1/4" diameter, available in polished chrome with black nylon glides, or 4" turned solid oak leg available in natural oak, medium walnut on oak and ebonized oak with white nylon glides.
<i>Example:</i> 21623R-0313-S-K1152/8-K1024/3	<i>Upholstery/COM information:</i> Prices shown includes fabric or leather upholstery. Contact your Knoll representative for colors. Only approved KnollTextiles and Spinneybeck leathers may be ordered.	Railroad upholstery application is standard for all non-directional textiles. Please see 'Stitching' for seam details.
2163R	D’Urso Residential Lounge Collection, ottoman	<i>Cushions:</i> Seat cushions constructed of highly resilient polyurethane foam and polyester fiber, wrapped in polyester fiber batting. Back cushion constructed with a soft polyurethane foam core and polyester fiber fill. Side cushion constructed of 10/90 down with a down proof ticking.
0313	Burnt Walnut legs	Leather cushions feature a perforated zipper breather panel.
S	Split upholstery	
K1152/8	Surround in Stirling, Cobble	
K1024/3	Cushions in Coco, Ciel	
<i>Specify:</i>	<i>Maintenance:</i> See pages 28-29.	
1. Pattern number		
2. Leg finish		
3. Textile selection		
<i>Specify with split upholstery:</i>		
1. Pattern number		
2. Leg finish		
3. Split upholstery option		
4. Textile selection, Surround		
5. Textile selection, Cushions		

pattern no.	grade A	COM B	C	D	E	F	G	H	I	COL U	V	W	X	Y
2162R-(-)(-)	\$8,457.	\$8,826.	\$9,177.	\$9,563.	\$9,878.	\$10,106.	\$10,492.	\$11,227.	\$11,771.	\$15,619.	\$16,891.	\$19,477.	\$20,015.	\$20,643.
2162RS-(-)(-)(-)	6,452.	6,735.	7,001.	7,296.	7,537.	7,712.	8,005.	8,566.	8,981.	11,206.	12,119.	13,974.	14,360.	14,812.
upchg, cushions	2,765.	2,886.	3,001.	3,128.	3,229.	3,304.	3,431.	3,671.	3,850.	4,804.	5,193.	5,990.	6,154.	6,348.
2163R-(-)(-)	2,632.	2,739.	2,841.	2,954.	3,045.	3,113.	3,224.	3,439.	3,599.	4,086.	4,315.	4,781.	4,879.	4,992.
2163RS-(-)(-)(-)	2,007.	2,091.	2,167.	2,253.	2,323.	2,376.	2,461.	2,625.	2,746.	2,932.	3,097.	3,431.	3,499.	3,581.
upchg, cushions	860.	895.	929.	966.	996.	1,018.	1,056.	1,126.	1,176.	1,256.	1,327.	1,471.	1,501.	1,536.
2162P-(-)	486.	512.	536.	563.	583.	600.	627.	678.	716.					

Approved KnollTextiles Grades/Fabrics					Spinneybeck Leather								
A Alignment # Beacon Bocce Cat’s Cradle Common Ground Commuter Cloth # Crossroad Delite Dristi Hourglass Mariner Monarch # Overture Prep # Presto # Sonnet Trophy Uni-Form	B continued Melody Mini Stitch # Paradigm Pogo Prairie Prim Radiance Ransom Rush Hour Spark # Spree Summit Sutton Synth Tabloid Tinge Venue Versa Vinyl Westwood Wide Angle # Zipline	C continued Echo Empire Stripe Enmesh # Entourage Essence Fable CR Fibra Hudson Hula Hoop Kaleidoscope CR Kora CR Lagos Legend CR Lore CR Metro Milestone Moto CR Palisade Panache CR Pullman Quark Roundtrip Sahara Sequin CR Spectator * Spot On Star Struck Stepping Stones Swing Tilden Wit Zari CR	D Compass CR Coterie Eclat Weave Hologram Island Kabuki Masquerade Menagerie Woodland Zoom	E Aegean Demure Highland Ikat Stripe Katazome Kimono Mamba Marquee Merue Sherman Shima Tryst Whip	F Atelier Calais Cotton Velvet Cornaro Icon Intrigue In Stitches Liberty Mod Plaid Rivington Soon Topography Totem Tweed Frieze	G Alter Ego Gibson Haze Melange Modern Tweed Petite Floral Spencer Ultrasuede #	H Arno # Constance Firefly Magritte	I Byron Cato Diamond Days Dynamic Knoll Velvet Piper Tudor Vermeer Zimba	U Vicenza # Volo #	V Acqua # Andes # Embossed Tipped España # Hand Tipped # Velluto Pelle #	W Alaska # Amazon # Antique # Derby # Forte # Lucente Sabrina # Umbria * Approved for 2162P only.	X Ducale Ducale Velour #	Y Cervo Copenhagen # Distressed # Marissa # Riva # Saddle #

Check with your KnollTextiles or Spinneybeck Representative for additions or changes.

Joseph Paul D’Urso Swivel Lounge Seating

description	seat h,	seat h,	w	d	h, min	h, max	textile	req.	weight
	min	max					fabric	leather	
	yds.	sq. ft.							
2165 Swivel Lounge chair	17"	20"	32"	30"	25 3/4"	28 3/4"	4.25	100	52 lbs.

Designer(s):
Joseph Paul D’Urso, 2008

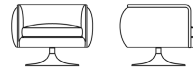

pattern no.	grades	COM	C	D	E	F	G	H	I	U	V	W	X	Y
2165-(-)(-)(-)	A	B												
	\$3,197.	\$3,305.	\$3,408.	n/a	n/a	\$3,683.	n/a	\$4,013.	\$4,174.	n/a	\$6,451.	\$7,305.	n/a	\$7,690.

Order Code	Ordering Information	Construction
<i>Example:</i> 2165-RC-AP-K1320/4	<i>Frame finish:</i> Polished Aluminum (suffix AP) Textured Black (suffix TB) Warm White (suffix WW)	<i>Frame:</i> Inner frame of solid wood and bent laminate plywood.
2165 Joseph Paul D’Urso Swivel lounge	<i>Maintenance:</i> See pages 28-29.	<i>Base:</i> Die cast aluminum base available in polished aluminum or powder coat paint finish.
RC Return to center mechanism	<i>Note:</i> The KnollStudio logo and signature of Joseph Paul D’Urso are located on the underside of chair.	<i>Upholstery:</i> Textile application must be railroaded. Urethane foam with polyester top layer wraps interior frame and a fully upholstered panel surrounds chair.
AP Polished Aluminum	<i>Upholstery/COM information:</i> Prices shown include fabric upholstery. Contact your Knoll representative for colors. Only approved KnollTextiles may be ordered.	<i>Leather upholstery features two vertical double-needle top stitched seams on the outside back of the chair.</i>
K1320/4 Comaro, Tabasco	Customer’s Own Material in textile applications is limited. For approval requirements, processing instructions and ordering information please see page 13.	<i>Cushion:</i> Urethane foam with polyester fiber wrap. Case with a single needle-top stitch detail.
<i>Note:</i> The Joseph Paul D’Urso Swivel lounge chair is part of a collection. Please refer to the Joseph Paul D’Urso Lounge and Table Collections on pages 106, 110, 298, 300 and 304.		
<i>Specify:</i> 1. Pattern number 2. Return to center mechanism, option 3. Frame finish 4. Textile selection		

Control:	Approved KnollTextiles Grades/Fabrics	Spinneybeck Leather
360° Swivel mechanism with pneumatic seat height adjustment, cable operated with a low profile lever, flush mounted on the underside of the chair.	A Mariner Sonnet	V Andes Espana
<i>Return to center mechanism:</i> Optional return to center mechanism allows for 360° swivel movement and returns to a center position when not engaged. Available as fixed height only with an 19" seat height and a 27 3/4" overall height.	B Knoll Felt # Knoll Hopsack Little Devil Melody Sutton	Y Marissa Riva Torello
To specify return to center mechanism, add suffix RC following parent pattern number.	C Classic Boucle	W Sabrina
	F Cornaro Rivington	
	G Modern Tweed	
	H Arno Bavaria Stretch Appeal	
	I Aswan Cato North Island Vermeer	
		<i>Check with your KnollTextiles Representative for changes or additions.</i>

Raul de Armas de Armas Chair

Designer(s):
Raul de Armas, 1991



description	seat h	arm h	w	d	h	textile	req.	weight	finish	
						fabric yds/ welt	leather sq. ft.			
38A Arm chair, upholstered seat, no welt	17 1/2"	25 1/2"	21 1/4"	22 1/2"	33 1/2"	0.7/1.4	13	17 lbs.	other finishes	
38AW Arm chair, upholstered seat, with welt	17 1/2"	25 1/2"	21 1/4"	22 1/2"	33 1/2"	0.7/1.4	13	16 lbs.	maple	
<hr/>										
38AW-U Arm chair, fully upholstered, with welt	17 1/2"	25 1/2"	21 1/4"	22 1/2"	33 1/2"	1.5	27	18 lbs.	other finishes	
	17 1/2"	25 1/2"	21 1/4"	22 1/2"	33 1/2"	1.5	27	17 lbs.	maple	

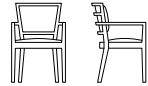
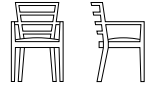

Order Code

<i>Example:</i>	38A-B319-K787/174
38A	de Armas arm chair, upholstered seat
B319	Medium Cherry
K787/174	Calais Cotton Velvet, Black Plum

Specify:

1. Pattern number
2. Finish selection
3. Cal 133 Fire Code option
4. Textile selection

Ordering Information:

Maple:
Clear Maple (suffix KC)

Beech frame stains:
Beech (suffix B311)
Bronzed Cherry (suffix B312A)
Burnt Walnut (suffix B313)
Deep Red Mahogany (suffix B328)
Ebonized (suffix BE)
Light Cherry (suffix B315)
Medium Cherry (suffix B319)
Medium Red Mahogany (suffix BR)
Medium Walnut (suffix B323)
Natural Beech (suffix BN)
Warm Brown Walnut (suffix J)

Ordering Information

Upholstery/COM information:
Prices shown include fabric or leather upholstery. Contact your Knoll representative for colors. Only approved KnollTextiles and Spinneybeck leathers may be ordered.

Customer's Own Material is available pending approval. For approval requirements, processing instructions and ordering information please see page 18.

KnollStudio wood finishes:
KnollStudio wood finishes complement a large variety of KnollStudio veneer and Knoll Office veneer finishes. To select correct complementary finish, please refer to KnollStudio Wood Finish Matrix on page 25. Complimentary finishes are available at no upcharge. If no complementary standard finish is available, please refer to custom finish policy below.

Custom finishes:
To complement non-Knoll wood veneer or lumber finishes, a one-time, non-negotiable net upcharge of \$662 applies. Re-orders are at no upcharge.

Please contact your KnollStudio representative, dealer or Customer Service associate for complete custom finish information and Order Code. Minimum order quantity for any custom finish order: 4 chairs.

Cal 133 Fire Code **▲** :
The de Armas Chairs comply with the California Technical Bulletin 133 standard if upholstered in Cal 133 approved upholstery. Specify suffix -C at end of pattern number and suffix -133 at end of textile selection. Upcharge applies, see page 18.

Certified Wood:
Chairs manufactured using FSC certified hardwoods are available through Custom Product Development. Extended leadtime and upcharge apply.

Maintenance:
See pages 28-29.

Note:
The de Armas Chair is Greenguard certified.

Construction

Frame:
Select clear maple hardwood in clear finish or select beech hardwood in stained finish.

Finish:
Catalyzed lacquer protective coating. Hand-applied final wax coating.

Seat:
Highly elastic woven membrane suspension with polyurethane foam insert.

Upholstery:
Inset seat available with optional welt detail. Fully upholstered features inset back with welt detail.

Glides:
Recessed plastic glides.

High Traffic Areas:
When specifying armless chair in high use or high traffic areas, we recommend the use of a stretcher for added strength. Contact CPD or your KnollStudio sales representative for more information.

pattern no.	grades	COM								COL					
	A	B	C	D	E	F	G	H	I	U	V	W	X	Y	
38A-() or 38AW-()	\$1,438.	\$1,465.	\$1,494.	\$1,511.	\$1,530.	\$1,548.	\$1,565.	\$1,612.	\$1,688.	\$1,866.	\$1,973.	\$2,182.	\$2,228.	\$2,277.	
38A-KC or 38AW-KC	1,580.	1,606.	1,634.	1,653.	1,670.	1,688.	1,706.	1,750.	1,828.	2,006.	2,113.	2,321.	2,368.	2,418.	
<hr/>															
38AW-U-()	2,155.	2,201.	2,243.	2,292.	2,330.	2,359.	2,406.	2,499.	2,566.	2,827.	2,988.	3,320.	3,389.	3,467.	
38AW-U-KC	2,362.	2,407.	2,451.	2,501.	2,538.	2,567.	2,614.	2,706.	2,773.	3,035.	3,195.	3,527.	3,598.	3,675.	

Approved KnollTextiles Grades/Fabrics

A Alignment *▲ Beacon * Bocce * Cat's Cradle * Chance * Common Ground * Commuter Cloth *▲ Crossroad Delite * Dristi * Foil Rap * Heavy Metal * Hourglass Mariner * Monarch *▲ Overture * Prep *▲ Presto *▲ Sonnet * Trophy * Uni-Form *	B continued Gala II * Grandview * Grande * Helios * Holbrook * Journey * Keaton * Knoll Felt * Knoll Hopsack * Little Devil * Ludlow * Lyric * Melody * Mini Stitch *▲ Paradigm * Petal Pusher * Prairie * Prim *▲ Radiance * Ransom * Roam * Rush Hour * Spark *▲ Spree * Summit * Sutton *▲ Synth * Tabloid * Utmost * Venue * Versa * Vinyl * Westwood * Wide Angle *▲ Yeni *	C Axiom * Atlas * Baxter * Cairo * Charm * Circa * Classic Boucle * Dahlia CR * Decade * Durand * Earthwork * Echo * Empire Stripe * Enmesh *▲ Entourage * Essence * Fable CR * Fibra * Greenwich * Hudson * Hula Hoop * Kaleidoscope CR * Kora CR * Lagos * Legend CR * Lore CR * Magnolia * Metro * Milestone * Moto CR * Noble * Palisade * Panache CR * Pullman *	C continued Quark * Roundtrip * Sahara * Sequin CR * Sinclair * Smart * Spectator * Spot On * Star Struck * Stepping Stones * Swing * Tight Rope * Tilden * Tower Grid * Treble CR * Wit * Zari CR *	D Compass CR * Coterie * Eclat Weave * Hologram * In The Loop * * Island * Masquerade * Menagerie * Origins * Woodland * Zoom *	E Aegean * Cleo * Demure * Highland * Ikat Stripe * Juno * Katazome * Kimono * Mamba * Marquee * Meroe * Midpoint Nature Walk Sherman * Shima * Tryst * Vatera * Whip *	F Atelier * Biscayne * Calais Cotton Velvet * Clider * Icon * Intrigue * In Stitches * Liberty * Mod Plaid * Rivington * Soon * Topography * Totem * Tweed Frieze *	G Alter Ego * Arber * Gibson * Haze * Kamani *	G continued Melange * Modern Tweed * Petite Floral * Serendipity * Spencer * Straie Stripe * Spectator * Ultrasuede *▲ Utrillo * H Arno * Bavaria * * Catwalk * Constance * Firefly * Magritte * Stretch Appeal * I Aswan * Byron * Cato * * Cummings * Diamond Days * Dynamic * Ita * Jaipur * Knoll Velvet *▲ Limani * Mepal * North Island * * Olema * Piper * Rutledge * Sandis * Tudor * Vermeer * Zimba *	U Vicenza *▲ Volo *▲ V Acqua *▲ Andes *▲ Embossed Tipped * España *▲ Hand Tipped * * Velluto Pelle *▲ W Alaska *▲ Amazon *▲ Antique *▲ Derby * *▲ Forte *▲ Lucente Sabrina *▲ Umbria *	X Ducale * *▲ Ducale Velour * *▲ Y Cervo * Copenhagen *▲ Distressed *▲ Gemma * Lucca * Marissa * *▲ Portofino * * Riva *▲ Saddle * *▲ Torello *
---	---	--	--	---	--	--	--	---	---	--

Spinneybeck Leather

* Approved for fully upholstered versions.
* * Approved for seat pad with no welting only.
▲ Approved for Cal 133 upholstery.

Check with your KnollTextiles or Spinneybeck Representative for changes or additions.

Raul de Armas de Armas Chair

description	seat h	arm h	w	d	h	textile	req.	weight	finish
						fabric	leather		
	yds/ welt	sq. ft.							
38C Armless chair, upholstered seat, no welt	17 1/2"		21 1/4"	22 1/2"	33 1/2"	0.7/1.4	13	15 lbs.	other finishes
38CW Armless chair, upholstered seat, with welt	17 1/2"		21 1/4"	22 1/2"	33 1/2"	0.7/1.4	13	15 lbs.	maple

Designer(s):
Raul de Armas, 1991

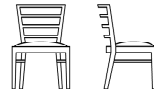

Order Code	Ordering Information	Construction
------------	----------------------	--------------

<i>Example:</i> 38A-B319-K787/174		
38A	de Armas arm chair, upholstered seat	
B319	Medium Cherry	
K787/174	Calais Cotton Velvet, Black Plum	

Specify:

1. Pattern number
2. Finish selection
3. Cal 133 Fire Code option
4. Textile selection

Ordering Information:

Maple:
Clear Maple (suffix KC)

Beech frame stains:
Beech (suffix B311)
Bronzed Cherry (suffix B312A)
Burnt Walnut (suffix B313)
Deep Red Mahogany (suffix B328)
Ebonized (suffix BE)
Light Cherry (suffix B315)
Medium Cherry (suffix B319)
Medium Red Mahogany (suffix BR)
Medium Walnut (suffix B323)
Natural Beech (suffix BN)
Warm Brown Walnut (suffix J)

Upholstery/COM information:
Prices shown include fabric or leather upholstery. Contact your Knoll representative for colors. Only approved KnollTextiles and Spinneybeck leathers may be ordered.

Customer's Own Material is available pending approval. For approval requirements, processing instructions and ordering information please see page 18.

KnollStudio wood finishes:
KnollStudio wood finishes complement a large variety of KnollStudio veneer and Knoll Office veneer finishes. To select correct complementary finish, please refer to KnollStudio Wood Finish Matrix on page 25. Complimentary finishes are available at no upcharge. If no complementary standard finish is available, please refer to custom finish policy below.

Custom finishes:
To complement non-Knoll wood veneer or lumber finishes, a one-time, non-negotiable net upcharge of \$662 applies. Re-orders are at no upcharge.

Please contact your KnollStudio representative, dealer or Customer Service associate for complete custom finish information and Order Code. Minimum order quantity for any custom finish order: 4 chairs.

Cal 133 Fire Code **▲** :
The de Armas Chairs comply with the California Technical Bulletin 133 standard if upholstered in Cal 133 approved upholstery. Specify suffix -C at end of pattern number and suffix -133 at end of textile selection. Upcharge applies, see page 18.

Certified Wood:
Chairs manufactured using FSC certified hardwoods are available through Custom Product Development. Extended leadtime and upcharge apply.

Maintenance:
See pages 28-29.

Note:
The de Armas Chair is Greenguard certified.

Frame:
Select clear maple hardwood in clear finish or select beech hardwood in stained finish.

Finish:
Catalyzed lacquer protective coating. Hand-applied final wax coating.

Seat:
Highly elastic woven membrane suspension with polyurethane foam insert.

Upholstery:
Inset seat available with optional welt detail. Fully upholstered features inset back with welt detail.

Glides:
Recessed plastic glides.

High Traffic Areas:
When specifying armless chair in high use or high traffic areas, we recommend the use of a stretcher for added strength. Contact CPD or your KnollStudio sales representative for more information.

pattern no.	grades	COM								COL				
	A	B	C	D	E	F	G	H	I	U	V	W	X	Y
38C-() or 38CW-()	\$1,360.	\$1,388.	\$1,419.	\$1,435.	\$1,454.	\$1,470.	\$1,491.	\$1,533.	\$1,614.	\$1,793.	\$1,898.	\$2,107.	\$2,149.	\$2,201.
38C-KC or 38CW-KC	1,496.	1,524.	1,554.	1,570.	1,588.	1,606.	1,626.	1,668.	1,746.	1,928.	2,032.	2,241.	2,283.	2,336.

Approved KnollTextiles Grades/Fabrics	Spinneybeck Leather
---------------------------------------	---------------------

- A** Alignment *▲
Beacon *
Bocce *
Cat's Cradle *
Chance *
Common Ground *
Commuter Cloth *▲
Crossroad
Delite *
Dristi *
Foil Rap *
Heavy Metal *
Hourglass
Mariner *
Monarch *▲
Overture *
Prep *▲
Presto *▲
Sonnet *
Trophy *
Uni-Form *
- B** Abacus *▲
Argyle *
Backdrop **
Belize
Bistro *▲
Boundary *▲
Calypso *
Cameo *
Chroma *▲
Chronicle *
Close Knit *
Digital Tape
Dovetail *▲
Fast Forward **
Ferry *
Forza *
- C** continued
Gala II *
Grandview *
Grande *
Helios *
Holbrook *
Journey *
Keaton *
Knoll Felt *
Knoll Hopsack *
Little Devil *
Ludlow *
Lyric *
Melody *
Mini Stitch *▲
Paradigm *
Petal Pusher *
Prairie *
Prim *▲
Radiance *
Ransom *
Roam *
Rush Hour *
Spark *▲
Spree *
Summit *
Sutton *▲
Synth *
Tabloid *
Utmost *
Venue *
Versa *
Vinyl *
Westwood *
Wide Angle *▲
Yeni *
- D** continued
Axiom *
Atlas *
Baxter *
Cairo *
Charm *
Circa *
Classic Boucle *
Dahlia CR *
Decade *
Durand *
Earthwork *
Echo *
Empire Stripe *
Enmesh *▲
Entourage *
Essence *
Fable CR *
Fibra *
Greenwich *
Hudson *
Hula Hoop *
Kaleidoscope CR *
Kora CR *
Lagos *
Legend CR *
Lore CR *
Magnolia *
Metro *
Milestone *
Moto CR *
Noble *
Palisade *
Panache CR *
Pullman *
- E** continued
Quark *
Roundtrip *
Sahara *
Sequin CR *
Sinclair *
Smart *
Spectator *
Spot On *
Star Struck *
Stepping Stones *
Swing *
Tight Rope *
Tilden *
Tower Grid *
Treble CR *
Wit *
Zari CR *
- F** continued
Compass CR *
Coterie *
Eclat Weave *
Hologram *
In The Loop **
Island *
Masquerade *
Menagerie *
Origins *
Woodland *
Zoom *
- G** continued
Aegean *
Cleo *
Demure *
Highland *
Ikat Stripe *
Juno *
Katazome *
Kimono *
Mamba *
Marquee *
Meroe *
Midpoint
Nature Walk
Sherman *
Shima *
Tryst *
Vatera *
Whip *
- H** continued
Arno *
Bavaria **
Catwalk *
Constance *
Firefly *
Magritte *
Stretch Appeal *
- I** continued
Aswan *
Byron *
Cato **
Cummings *
Diamond Days *
Dynamic *
Ita *
Jaipur *
Knoll Velvet *▲
Limani *
Mepal *
North Island **
Olema *
Piper *
Rutledge *
Sandis *
Tudor *
Vermeer *
Zimba *
- U** continued
Melange *
Modern Tweed *
Petite Floral *
Serendipity *
Spencer *
Straie Stripe *
Spectator *
Ultrasuede *▲
Utrillo *
- V** continued
Acqua *▲
Andes *▲
Embossed Tipped *
España *▲
Hand Tipped **
Velluto Pelle *▲
- W** continued
Alaska *▲
Amazon *▲
Antique *▲
Derby **▲
Forte *▲
Lucente
Sabrina *▲
Umbria *
- X** continued
Ducale **▲
Ducale Velour **▲
- Y** continued
Cervo *
Copenhagen *▲
Distressed *▲
Gemma *
Lucca *
Marissa **▲
Portofino **
Riva *▲
Saddle **▲
Torello *

* Approved for fully upholstered versions.
** Approved for seat pad with no welting only.
▲ Approved for Cal 133 upholstery.

Check with your KnollTextiles or Spinneybeck Representative for changes or additions.

Raul de Armas de Armas Chair

Designer(s):
Raul de Armas, 1991



description	seat h	arm h	w	d	h	textile	req.	weight	finish
						fabric yds/ welt	leather sq. ft.		
38CW-U Armless chair, fully upholstered, with welt	17 1/2"		21 1/4"	22 1/2"	33 1/2"	1.5	27	16 lbs.	other finishes
	17 1/2"		21 1/4"	22 1/2"	33 1/2"	1.5	27	16 lbs.	maple
38R Seat basket replacement						0.7/1.4	13		

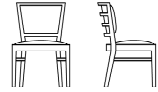

Order Code

<i>Example:</i>	38A-B319-K787/174
38A	de Armas arm chair, upholstered seat
B319	Medium Cherry
K787/174	Calais Cotton Velvet, Black Plum

Specify:

1. Pattern number
2. Finish selection
3. Cal 133 Fire Code option
4. Textile selection

Ordering Information:

Maple:
Clear Maple (suffix KC)

Beech frame stains:
Beech (suffix B311)
Bronzed Cherry (suffix B312A)
Burnt Walnut (suffix B313)
Deep Red Mahogany (suffix B328)
Ebonized (suffix BE)
Light Cherry (suffix B315)
Medium Cherry (suffix B319)
Medium Red Mahogany (suffix BR)
Medium Walnut (suffix B323)
Natural Beech (suffix BN)
Warm Brown Walnut (suffix J)

Ordering Information

Upholstery/COM information:
Prices shown include fabric or leather upholstery. Contact your Knoll representative for colors. Only approved KnollTextiles and Spinneybeck leathers may be ordered.

Customer's Own Material is available pending approval. For approval requirements, processing instructions and ordering information please see page 18.

KnollStudio wood finishes:
KnollStudio wood finishes complement a large variety of KnollStudio veneer and Knoll Office veneer finishes. To select correct complementary finish, please refer to KnollStudio Wood Finish Matrix on page 25. Complimentary finishes are available at no upcharge. If no complementary standard finish is available, please refer to custom finish policy below.

Custom finishes:
To complement non-Knoll wood veneer or lumber finishes, a one-time, non-negotiable net upcharge of \$662 applies. Re-orders are at no upcharge.

Please contact your KnollStudio representative, dealer or Customer Service associate for complete custom finish information and Order Code. Minimum order quantity for any custom finish order: 4 chairs.

Cal 133 Fire Code :
The de Armas Chairs comply with the California Technical Bulletin 133 standard if upholstered in Cal 133 approved upholstery. Specify suffix -C at end of pattern number and suffix -133 at end of textile selection. Upcharge applies, see page 18.

Certified Wood:
Chairs manufactured using FSC certified hardwoods are available through Custom Product Development. Extended leadtime and upcharge apply.

Maintenance:
See pages 28-29.

Note:
The de Armas Chair is Greenguard certified.

Construction

Frame:
Select clear maple hardwood in clear finish or select beech hardwood in stained finish.

Finish:
Catalyzed lacquer protective coating. Hand-applied final wax coating.

Seat:
Highly elastic woven membrane suspension with polyurethane foam insert.

Upholstery:
Inset seat available with optional welt detail. Fully upholstered features inset back with welt detail.

Glides:
Recessed plastic glides.

High Traffic Areas:
When specifying armless chair in high use or high traffic areas, we recommend the use of a stretcher for added strength. Contact CPD or your KnollStudio sales representative for more information.

pattern no.	grades A	COM B	C	D	E	F	G	H	I	COL U	V	W	X	Y
38CW-U(-)	\$1,940.	\$1,983.	\$2,028.	\$2,075.	\$2,115.	\$2,143.	\$2,191.	\$2,280.	\$2,350.	\$2,618.	\$2,779.	\$3,095.	\$3,179.	\$3,258.
38CW-U-KC	2,126.	2,169.	2,213.	2,262.	2,302.	2,328.	2,378.	2,466.	2,536.	2,804.	2,965.	3,282.	3,368.	3,447.
38R(-)	441.	466.	497.	513.	532.	548.	566.	612.	687.	870.	976.	1,182.	1,228.	1,277.

Approved KnollTextiles Grades/Fabrics

A Alignment *▲ Beacon * Bocce * Cat's Cradle * Chance * Common Ground * Commuter Cloth *▲ Crossroad Delite * Dristi * Foil Rap * Heavy Metal * Hourglass Mariner * Monarch *▲ Overture * Prep *▲ Presto *▲ Sonnet * Trophy * Uni-Form *	B Abacus *▲ Argyle * Backdrop ** Belize Bistro *▲ Boundary *▲ Calypso * Cameo * Chroma *▲ Chronicle * Close Knit * Digital Tape Dovetail *▲ Fast Forward ** Ferry * Forza *	C continued Gala II * Grandview * Grande * Helios * Holbrook * Journey * Keaton * Knoll Felt * Knoll Hopsack * Little Devil * Ludlow * Lyric * Melody * Mini Stitch *▲ Paradigm * Petal Pusher * Prairie * Prim *▲ Radiance * Ransom * Roam * Rush Hour * Spark *▲ Spree * Summit * Sutton *▲ Synth * Tabloid * Utmost * Venue * Versa * Vinyl * Westwood * Wide Angle *▲ Yeni *	C continued Quark * Roundtrip * Sahara * Sequin CR * Sinclair * Smart * Spectator * Spot On * Star Struck * Stepping Stones * Swing * Tight Rope * Tilden * Tower Grid * Treble CR * Wit * Zari CR *	D Compass CR * Coterie * Eclat Weave * Hologram * In The Loop ** Island * Masquerade * Menagerie * Origins * Woodland * Zoom *	E Aegean * Cleo * Demure * Highland * Ikat Stripe * Juno * Katazome * Kimono * Mamba * Marquee * Meroe * Midpoint Nature Walk Sherman * Shima * Tryst * Vatera * Whip *	F Atelier * Biscayne * Calais Cotton Velvet * Clider * Icon * Intrigue * In Stitches * Liberty * Mod Plaid * Rivington * Soon * Topography * Totem * Tweed Frieze *	G Alter Ego * Arber * Gibson * Haze * Kamani *	G continued Melange * Modern Tweed * Petite Floral * Serendipity * Spencer * Straie Stripe * Ultrasuede *▲ Utrillo *	H Arno * Bavaria ** Catwalk * Constance * Firefly * Magritte * Stretch Appeal *	I Aswan * Byron * Cato ** Cummings * Diamond Days * Dynamic * Ita * Jaipur * Knoll Velvet *▲ Limani * Mepal * North Island ** Olema * Piper * Rutledge * Sandis * Tudor * Vermeer * Zimba *	U Vicenza *▲ Volo *▲	V Acqua *▲ Andes *▲ Embossed Tipped * España *▲ Hand Tipped ** Velluto Pelle *▲	W Alaska *▲ Amazon *▲ Antique *▲ Derby **▲ Forte *▲ Lucente Sabrina *▲ Umbria *	X Ducale **▲ Ducale Velour **▲	Y Cervo * Copenhagen *▲ Distressed *▲ Gemma * Lucca * Marissa **▲ Portofino ** Riva *▲ Saddle **▲ Torello *
---	--	---	--	--	--	---	--	---	---	---	-----------------------------------	--	--	---	--

Spinneybeck Leather

U Vicenza *▲ Volo *▲	V Acqua *▲ Andes *▲ Embossed Tipped * España *▲ Hand Tipped ** Velluto Pelle *▲	W Alaska *▲ Amazon *▲ Antique *▲ Derby **▲ Forte *▲ Lucente Sabrina *▲ Umbria *
-----------------------------------	--	--

* Approved for fully upholstered versions.
** Approved for seat pad with no welting only.
▲ Approved for Cal 133 upholstery.

Check with your KnollTextiles or Spinneybeck Representative for changes or additions.

Raul de Armas

Vertical de Armas Chair

Designer(s):
Raul de Armas, 2000



description	seat h	arm h	w	d	h	textile	req.	weight	finish
						fabric	leather		
						yds/ welt	sq. ft.		
41A Arm chair, upholstered seat, no welt	17 1/2"	25 1/2"	21 1/4"	22 1/2"	33 1/2"	0.7/1.4	13	17 lbs.	other finishes
41AW Arm chair, upholstered seat, with welt	17 1/2"	25 1/2"	21 1/4"	22 1/2"	33 1/2"	0.7/1.4	13	16 lbs.	maple
41AW-U Arm chair, fully upholstered, with welt	17 1/2"	25 1/2"	21 1/4"	22 1/2"	33 1/2"	1.5	27	18 lbs.	other finishes
	17 1/2"	25 1/2"	21 1/4"	22 1/2"	33 1/2"	1.5	27	17 lbs.	maple
41R Seat basket replacement						0.7/1.4	13		

pattern no.	grades	COM	C	D	E	F	G	H	I	COL	U	V	W	X	Y
41A-() or 41AW-()	\$1,438.	\$1,465.	\$1,494.	\$1,511.	\$1,530.	\$1,548.	\$1,565.	\$1,612.	\$1,688.	\$1,866.	\$1,973.	\$2,182.	\$2,228.	\$2,277.	
41A-KC or 41AW-KC	1,580.	1,606.	1,634.	1,653.	1,670.	1,688.	1,706.	1,750.	1,828.	2,006.	2,113.	2,321.	2,368.	2,418.	
41AW-U-()	2,155.	2,201.	2,243.	2,292.	2,330.	2,359.	2,406.	2,499.	2,566.	2,827.	2,988.	3,320.	3,389.	3,467.	
41AW-U-KC	2,362.	2,407.	2,451.	2,501.	2,538.	2,567.	2,614.	2,706.	2,773.	3,035.	3,195.	3,527.	3,598.	3,675.	
41R-()	441.	466.	497.	513.	532.	548.	566.	612.	687.	870.	976.	1,182.	1,228.	1,277.	

Order Code

<i>Example:</i>	41A-B319-K787/174
41A	de Armas arm chair
B319	Medium Cherry
K787/174	Calais Cotton Velvet, Black Plum

Specify:

1. Pattern number
2. Finish selection
3. Cal 133 Fire Code option
4. Textile selection

Ordering Information:

Maple:
Clear Maple (suffix KC)

Beech frame stains:
Beech (suffix B311)
Bronzed Cherry (suffix B312A)
Burnt Walnut (suffix B313)
Deep Red Mahogany (suffix B328)
Ebonized (suffix BE)
Light Cherry (suffix B315)
Medium Cherry (suffix B319)
Medium Red Mahogany (suffix BR)
Medium Walnut (suffix B323)
Natural Beech (suffix BN)
Warm Brown Walnut (suffix J)

Ordering Information

Upholstery/COM information:
Prices shown include fabric or leather upholstery. Contact your Knoll representative for colors. Only approved KnollTextiles and Spinneybeck leathers may be ordered.

Customer's Own Material is available pending approval. For approval requirements, processing instructions and ordering information please see page 18.

KnollStudio wood finishes:
KnollStudio wood finishes complement a large variety of KnollStudio veneer and Knoll Office veneer finishes. To select correct complementary finish, please refer to KnollStudio Wood Finish Matrix on page 25. Complementary finishes are available at no upcharge. If no complementary standard finish is available, please refer to custom finish policy below.

Custom finishes:
To complement non-Knoll wood veneer or lumber finishes, a one-time, non-negotiable net upcharge of \$662 applies. Re-orders are at no upcharge.

Please contact your KnollStudio representative, dealer or Customer Service associate for complete custom finish information and Order Code. Minimum order quantity for any custom finish order: 4 chairs.

Cal 133 Fire Code :
The de Armas Chairs comply with the California Technical Bulletin 133 standard if upholstered in Cal 133 approved upholstery. Specify suffix -C at end of pattern number and suffix -133 at end of textile selection. Upcharge applies, see page 18.

Certified Wood:
Chairs manufactured using FSC certified hardwoods are available through Custom Product Development. Extended leadtime and upcharge apply.

Maintenance:
See pages 28-29.

Note:
The Vertical de Armas Chair is Greenguard certified.

Construction

Frame:
Select clear maple hardwood in clear finish or select beech hardwood in stained finish.

Finish:
Catalyzed lacquer protective coating. Hand-applied final wax coating.

Seat:
Highly elastic woven membrane suspension with polyurethane foam insert.

Upholstery:
Inset seat available with optional welt detail. Fully upholstered features inset back with welt detail.

Glides:
Recessed plastic glides.

High Traffic Areas:
When specifying armless chair in high use or high traffic areas, we recommend the use of a stretcher for added strength. Contact CPD or your KnollStudio sales representative for more information.

Approved KnollTextiles Grades/Fabrics

A Alignment *▲ Beacon * Boce * Cat's Cradle * Chance * Common Ground * Commuter Cloth *▲ Crossroad * Delite * Dristi * Foil Rap * Heavy Metal * Hourglass Mariner * Monarch *▲ Overture * Prep *▲ Presto *▲ Sonnet * Trophy * Uni-Form *	B continued Gala II * Grandview * Grande * Helios * Holbrook * Journey * Keaton * Knoll Felt * Knoll Hopsack * Little Devil * Ludlow * Melody * Mini Stitch *▲ Paradigm * Petal Pusher * Prairie * Prim *▲ Radiance * Ransom * Roam * Rush Hour * Spark *▲ Spree * Starry Night *▲ Summit * Sutton *▲ Synth * Tabloid * Tinge * Utmost * Venue * Versa * Vinyl * Westwood * Wide Angle *▲ Yeni *	C Axiom * Atlas * Baxter * Cairo * Charm * Circa * Classic Boucle * Dahlia CR * Decade * Durand * Earthwork * Echo * Empire Stripe * Emmesh *▲ Entourage * Essence * Fable CR * Fibra * Greenwich * Hudson * Hula Hoop * Kaleidoscope CR * Kora CR * Lagos * Legend CR * Lore CR * Magnolia * Metro * Milestone * Moto CR * Noble * Palisade * Panache CR * Pullman *	C continued Quark * Roundtrip * Sahara * Sequin CR * Sinclair * Smart * Spectator * Spot On * Star Struck * Stepping Stones * Swing * Tight Rope * Tilden * Tower Grid * Treble CR * Wit * Zari CR *	D Compass CR * Coterie * Eclat Weave * Hologram * In The Loop * * Island * Masquerade * Menagerie * Origins * Woodland * Zoom *	E Aegean * Cleo * Demure * Highland * Ikat Stripe * Juno * Katazome * Kimono * Mamba * Marquee * Meroe * Midpoint Nature Walk Sherman * Shima * Tryst * Vatera * Whip *	F Atelier * Biscayne * Calais Cotton Velvet * Cornaro * Glider * Icon * Intrigue * In Stitches * Liberty * Mod Plaid * Rivington * Soon * Topography * Totem * Tweed Frieze *	G continued Haze * Kamani * Melange * Modern Tweed * Petite Floral * Serendipity * Spencer * Straie Stripe * Ultrasuede *▲ Utrillo * Arno * Bavaria * * Catwalk * Constance * Firefly * Magritte * Stretch Appeal *	H Aswan * Byron * Cato * * Cummings * Diamond Days * Dynamic * Ita * Jaipur * Knoll Velvet *▲ Limani * Mepal * North Island * * Olema * Piper * Rutledge * Sandis * Tudor * Vermeer * Zimba *	I Espeña *▲ Embossed Tipped * España *▲ Hand Tipped * * Velluto Pelle *▲	U Vicenza *▲ Volo *▲	V Acqua *▲ Andes *▲ Espana *▲ Hand Tipped * * Velluto Pelle *▲	W Alaska *▲ Amazon *▲ Antique *▲ Derby * *▲ Forte *▲ Lucente Sabrina *▲ Umbria *	X Ducalle * *▲ Ducalle Velour * *▲	Y Cervo * Copenhagen *▲ Distressed *▲ Gemma * Lucca * Marissa * *▲ Portofino * * Riva *▲ Saddle * *▲ Torello *
---	---	--	--	---	--	--	---	---	--	-----------------------------------	--	---	---	---

Spinneybeck Leather

* Approved for fully upholstered versions. ** Approved for seat pad with no welting only. ▲ Approved for Cal 133 upholstery.
--

Check with your KnollTextiles or Spinneybeck Representative for changes or additions.

Raul de Armas

Vertical de Armas Chair

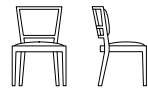
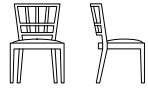

Designer(s):
Raul de Armas, 2000

description	seat h	arm h	w	d	h	textile	leather	weight	finish
						fabric yds/ welt	sq. ft.		
41C Armless chair, upholstered seat, no welt	17 1/2"		21 1/4"	22 1/2"	33 1/2"	0.7/1.4	13	15 lbs.	other finishes
41CW Armless chair, upholstered seat, with welt	17 1/2"		21 1/4"	22 1/2"	33 1/2"	0.7/1.4	13	16 lbs.	maple
41CW-U Armless chair, fully upholstered, with welt	17 1/2"		21 1/4"	22 1/2"	33 1/2"	1.5	27	16 lbs.	other finishes
	17 1/2"		21 1/4"	22 1/2"	33 1/2"	1.5	27	17 lbs.	maple
41R Seat basket replacement						0.7/1.4	13		

pattern no	grades	COM	C	D	E	F	G	H	I	COL	V	W	X	Y
	A	B								U				
41C-() or 41CW-()	\$1,360.	\$1,388.	\$1,419.	\$1,435.	\$1,454.	\$1,470.	\$1,491.	\$1,533.	\$1,614.	\$1,793.	\$1,898.	\$2,107.	\$2,149.	\$2,201.
41C-KC or 41CW-KC	1,496.	1,524.	1,554.	1,570.	1,588.	1,606.	1,626.	1,668.	1,746.	1,928.	2,032.	2,241.	2,283.	2,336.
41CW-U-()	1,940.	1,983.	2,028.	2,075.	2,115.	2,143.	2,191.	2,280.	2,350.	2,618.	2,779.	3,095.	3,179.	3,258.
41CW-U-KC	2,126.	2,169.	2,213.	2,262.	2,302.	2,328.	2,378.	2,466.	2,536.	2,804.	2,965.	3,282.	3,368.	3,447.
41R-()	441.	466.	497.	513.	532.	548.	566.	612.	687.	870.	976.	1,182.	1,228.	1,277.

Order Code	Ordering Information	Construction
------------	----------------------	--------------

Example: **41A-B319-K787/174**
41A de Armas arm chair
B319 Medium Cherry
K787/174 Calais Cotton Velvet, Black Plum

Upholstery/COM information:
 Prices shown include fabric or leather upholstery. Contact your Knoll representative for colors. Only approved KnollTextiles and Spinneybeck leathers may be ordered.

Please contact your KnollStudio representative, dealer or Customer Service associate for complete custom finish information and Order Code. Minimum order quantity for any custom finish order: 4 chairs.

Frame:
 Select clear maple hardwood in clear finish or select beech hardwood in stained finish.

Specify:
 1. Pattern number
 2. Finish selection
 3. Cal 133 Fire Code option
 4. Textile selection

Customer's Own Material is available pending approval. For approval requirements, processing instructions and ordering information please see page 18.

Cal 133 Fire Code :
 The de Armas Chairs comply with the California Technical Bulletin 133 standard if upholstered in Cal 133 approved upholstery. Specify suffix -C at end of pattern number and suffix -133 at end of textile selection. Upcharge applies, see page 18.

Finish:
 Catalyzed lacquer protective coating. Hand-applied final wax coating.

Seat:
 Highly elastic woven membrane suspension with polyurethane foam insert.

Upholstery:
 Inset seat available with optional welt detail. Fully upholstered features inset back with welt detail.

Ordering Information:
 Clear Maple (suffix KC)

KnollStudio wood finishes:
 KnollStudio wood finishes complement a large variety of KnollStudio veneer and Knoll Office veneer finishes. To select correct complementary finish, please refer to KnollStudio Wood Finish Matrix on page 25. Complementary finishes are available at no upcharge. If no complementary standard finish is available, please refer to custom finish policy below.

Certified Wood:
 Chairs manufactured using FSC certified hardwoods are available through Custom Product Development. Extended leadtime and upcharge apply.

Glides:
 Recessed plastic glides.

High Traffic Areas:
 When specifying armless chair in high use or high traffic areas, we recommend the use of a stretcher for added strength. Contact CPD or your KnollStudio sales representative for more information.

Beech frame stains:
 Beech (suffix B311)
 Bronzed Cherry (suffix B312A)
 Burnt Walnut (suffix B313)
 Deep Red Mahogany (suffix B328)
 Ebonized (suffix BE)
 Light Cherry (suffix B315)
 Medium Cherry (suffix B319)
 Medium Red Mahogany (suffix BR)
 Medium Walnut (suffix B323)
 Natural Beech (suffix BN)
 Warm Brown Walnut (suffix J)

Custom finishes:
 To complement non-Knoll wood veneer or lumber finishes, a one-time, non-negotiable net upcharge of \$662 applies. Re-orders are at no upcharge.

Note:
 The Vertical de Armas Chair is Greenguard certified.

Approved KnollTextiles Grades/Fabrics					Spinneybeck Leather				
---------------------------------------	--	--	--	--	---------------------	--	--	--	--

A Alignment *
 Beacon *
 Bocce *
 Cat's Cradle *
 Chance *
 Common Ground *
 Commuter Cloth *
 Crossroad *
 Delite *
 Dristi *
 Foil Rap *
 Heavy Metal *
 Hourglass
 Mariner *
 Monarch *
 Overture *
 Prep *
 Presto *
 Sonnet *
 Trophy *
 Uni-Form *

B Abacus *
 Argyle *
 Backdrop **
 Belize
 Bistro *
 Boundary *
 Calypso *
 Cameo *
 Chroma *
 Chronicle *
 Close Knit *
 Digital Tape *
 Dovetail *
 Fast Forward **
 Ferry *
 Forza *

C continued
 Gala II *
 Grandview *
 Grande *
 Helios *
 Holbrook *
 Journey *
 Keaton *
 Knoll Felt *
 Knoll Hopsack *
 Little Devil *
 Ludlow *
 Melody *
 Mini Stitch *
 Paradigm *
 Petal Pusher *
 Prairie *
 Prim *
 Radiance *
 Ransom *
 Roam *
 Rush Hour *
 Spark *
 Spree *
 Starry Night *
 Sutton *
 Synth *
 Tabloid *
 Tinge *
 Utmost *
 Venue *
 Versa *
 Vinyl *
 Westwood *
 Wide Angle *
 Yeni *

D continued
 Sinclair *
 Smart *
 Spectator *
 Spot On *
 Star Struck *
 Stepping Stones *
 Swing *
 Tight Rope *
 Tilden *
 Tower Grid *
 Treble CR *
 Wit *
 Zari CR *

E continued
 Axiom *
 Atlas *
 Baxter *
 Cairo *
 Charm *
 Circa *
 Classic Boucle *
 Dahlia CR *
 Decade *
 Durand *
 Earthwork *
 Echo *
 Empire Stripe *
 Enmesh *
 Entourage *
 Essence *
 Fable CR *
 Fibra *
 Greenwich *
 Hudson *
 Hula Hoop *
 Kaleidoscope CR *
 Kora CR *
 Lagos *
 Legend CR *
 Lore CR *
 Magnolia *
 Metro *
 Milestone *
 Moto CR *
 Noble *
 Palisade *
 Panache CR *
 Pullman *
 Quark *
 Roundtrip *
 Sahara *
 Sequin CR *

F continued
 Compass CR *
 Coterie *
 Eclat Weave *
 Hologram *
 In The Loop *
 Island *
 Masquerade *
 Menagerie *
 Origins *
 Woodland *
 Zoom *
 Aegean *
 Cleo *
 Demure *
 Highland *
 Ikat Stripe *
 Juno *

G continued
 Katazome *
 Kimono *
 Mamba *
 Marquee *
 Meroe *
 Midpoint
 Nature Walk
 Sherman *
 Shima *
 Tower Grid *
 Tryst *
 Vatera *
 Whip *

H Arno *
 Bavaria **
 Catwalk *
 Constance *
 Firefly *
 Magritte *
 Stretch Appeal *

I Aswan *
 Byron *
 Cato *
 Cummings *
 Diamond Days *
 Dynamic *
 Ita *
 Jaipur *
 Knoll Velvet *
 Limani *
 Mepal *
 North Island **
 Olema *
 Piper *
 Rutledge *
 Sandis *
 Tudor *
 Vermeer *
 Zimba *





U Vicenza *
 Volo *
V Acqua *
 Andes *
 Embossed Tipped *
 España *
 Hand Tipped **
 Velluto Pelle *
W Alaska *
 Amazon *
 Antique *
 Derby *
 Forte *
 Lucente
 Sabrina *
 Umbria *

X Ducale **
 Ducale Velour **
Y Cervo *
 Copenhagen *
 Gemma *
 Lucca *
 Marissa **
 Portofino **
 Riva *
 Saddle **
 Torello *

* Approved for fully upholstered versions.
 ** Approved for seat pad with no welting only.
 Approved for Cal 133 upholstery.

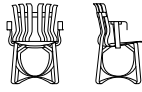
Check with your KnollTextiles or Spinneybeck Representative for changes or additions.

Frank Gehry Side and Dining Chairs

	description	seat h	arm h	w	d	h	textile fabric yds.	req. leather sq. ft.	weight
<i>Designer(s):</i> Frank Gehry, 1990	91A-GC Hat Trick arm chair 	18"	25 7/8"	23 3/8"	22 1/4"	33 1/2"			14 lbs.
		18"	25 7/8"	23 3/8"	22 1/4"	33 1/2"	0.8	15	14 lbs.
<i>Award(s):</i> ASID Award, 1992; ROSCOE Award, 1992; ID Magazine Gold Award, 1992; ICFE Award for Excellence, 1992; IBD Award (Silver), 1992; Premium Imperiale Award (Prince Takamatsu World Culture Award), 1992; Time Magazine, Best Design of 1992	91C-GC Hat Trick armless chair 	18"	20"	22 1/4"	33 1/2"				11 lbs.
		18"	20"	22 1/4"	33 1/2"	0.8	15		11 lbs.
	91K Seat cushion replacement for Hat Trick arm and armless chair						0.8	15	
	92C-GC High Sticking high back chair 	17 7/8"	20 1/8"	23 3/8"	43 3/8"				12 lbs.
		17 7/8"	20 1/8"	23 3/8"	43 3/8"	0.7	14		12 lbs.
	92K Seat cushion replacement						0.7	14	

Order Code

<i>Example:</i>	91A-GC-K-SA783
91A	Hat Trick arm chair
GC	Clear Maple
K	Seat cushion
SA783	Sabrina, Carmen
<i>Example:</i>	92K-K1320/4
92K	High sticking seat cushion replacement
K1320/4	Cornaro, Tabasco

Note:
The Gehry chairs are part of a collection. Please refer to Gehry tables on page 306.

- Specify:*
1. Pattern number
 2. Finish selection
 3. Textile selection

Seat cushion replacement, specify:

1. Pattern number
2. Textile selection

Ordering Information

Finishes:
Clear Maple (suffix GC)

Seat cushion option:
To specify seat cushion, add "K" to end of pattern number and then list textile/leather pattern number.

Upholstery/COM information:
Prices shown include fabric or leather upholstery. Contact your Knoll representative for colors. Only approved KnollTextiles and Spinneybeck leathers may be ordered.

Customer's Own Material is available pending approval. For approval requirements, processing instructions and ordering information please see page 18.

Construction

Hat Trick note:
Hat Trick arms are 9-ply and arm supports are a total of 26-ply for added strength. Arms may be retrofitted on armless Hat Trick chair, or removed from arm version. Easily added or removed with bolts. Contoured seat constructed of cross-ply maple for rigidity.

High Sticking note:
Built-in lumbar curve for enhanced back support. To maximize tension compression, limited assembly glue is used in woven seat: weaves flex in unison for spring-like comfort.

Note:
The underside of each piece is embossed with the Knoll logo and Frank Gehry's signature.

Maintenance:
See pages 28-29.

Frame:
Constructed of hard white maple veneers in 2" wide, 1/32" thick strips on Hat Trick and High Sticking chair, laminated to 7 to 9-ply thickness with high-bonding urea glue. All wood grains run in same direction for resilience. Thermo-set assembly glue provides structural rigidity without the need for metal connectors, while allowing for ergonomic movement and flexibility. Backs on all chairs flex for added comfort.

Cushions:
1/2" thick high resiliency foam on Hat Trick. 3/4" thick high resiliency foam on High Sticking. Hat Trick cushion "shower cap" design envelopes entire seat. Square High Sticking cushion snap-locks underneath chair.

Glides:
Clear plastic with matte frost finish.

pattern no.	unuphol.	grades A	COM B	C	D	E	F	G	H	I	COL U	V	W	X	Y
91A-GC	\$3,881.														
91A-GC-K		4,246.	4,268.	4,290.	4,313.	4,332.	4,346.	4,369.	4,413.	4,446.	4,562.	4,648.	4,817.	4,852.	4,893.
91C-GC	2,952.														
91C-GC-K		3,318.	3,340.	3,360.	3,384.	3,404.	3,416.	3,440.	3,486.	3,518.	3,637.	3,718.	3,889.	3,924.	3,964.
91K-()		439.	462.	480.	504.	525.	537.	562.	607.	639.	758.	841.	1,008.	1,044.	1,086.
92C-GC	5,073.														
92C-GC-K		5,439.	5,463.	5,483.	5,506.	5,526.	5,537.	5,562.	5,607.	5,639.	5,734.	5,812.	5,969.	6,001.	6,038.
92K-()		471.	494.	515.	538.	558.	569.	595.	640.	672.	765.	844.	1,000.	1,033.	1,070.



Approved KnollTextiles Grades/Fabrics

- | | | | | | | | |
|---|--|---|---|--|--|--|--|
| A
Alignment
Beacon
Bocce
Chance
Common Ground
Commuter Cloth
Crossroad
Delite
Dristi
Hourglass
Mariner
Overture
Prep
Presto
Soliloquy
Sonnet
Trophy
Uni-Form | B
Abacus
Argyle
Belize
Bistro
Boundary
Calypso
Cameo
Chroma
Chronicle
Close Knit
Diva
Dovetail
Ferry
Forza
Gala II
Grande
Grandview
Helios
Holbrook
Journey
Keaton
Knoll Felt
Knoll Hopsack
Little Devil
Ludlow
Melody
Mini Stitch | C
Charm
Circa
Classic Boucle
Dahlia CR
Decade
Dune
Durand | E
continued
Paradigm
Pogo
Prairie
Prim #
Radiance
Ransom
Roam
Rush Hour
Spark
Spree
Summit
Sutton
Synth
Tabloid
Utmost
Venue
Versa
Vinyl
Westwood
Wide Angle
Zipline | C continued
Earthwork
Echo
Empire Stripe
Enmesh
Entourage
Essence
Fibra
Greenwich
Hudson
Hula Hoop
Kora CR
Lagos
Legend CR
Lore CR
Magnolia
Metro
Milestone
Moto CR
Noble
Palisade
Panache CR
Pullman
Quark
Roundtrip
Sequin CR
Sinclair
Smart
Spot On
Star Struck
Stepping Stones
Swing
Tilden
Tower Grid | C continued
Treble CR
Zari CR | D
Compass CR
Coterie
Eclat Weave
Hologram
Island
Masquerade
Menagerie
Origins
Woodland
Zoom | E
Aegean
Cleo
Demure
Highland
Ikata Stripe
Katazome
Kimono
Mamba
Marquee
Midpoint
Nature Walk
Sherman
Shima
Tryst
Vatera |
|---|--|---|---|--|--|--|--|

Spinneybeck Leather

- | | | | |
|--|---|--|--|
| U
Vicenza
Volo | V
Acqua
Andes
Embossed Tipped
España
Velluto Pelle | W
Alaska
Amazon
Antique
Forte
Lucente
Sabrina
Umbria | X
Ducale
Ducale Velour
<i>Check with your KnollTextiles or Spinneybeck Representative for changes or additions.</i> |
| Y
Cervo
Copenhagen
Distressed
Gemma
Lucca
Marissa
Riva | I
Aswan
Byron
Diamond Days
Dynamic
Ita
Jaipur
Knoll Velvet
Limani
North Island
Olema
Piper
Rutledge
Sandis
Tudor
Vermeer
Zimba | H
Arno
Bavaria
Catwalk
Firefly
Magritte
Stretch Appeal | F
Atelier
Biscayne
Calais Cotton
Velvet
Cornaro
Glider
Icon
Intrigue
In Stitches
Liberty
Mod Plaid
Rivington
Topography
Totem
Tweed Frieze |

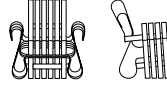
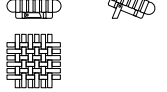
Frank Gehry Lounge Seating

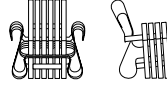
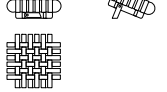
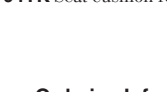
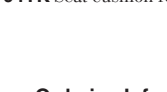
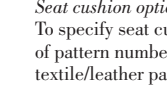
	description	seat h	arm h	w	d	h	textile fabric yds.	req. leather sq. ft.	weight
<i>Designer(s):</i> Frank Gehry, 1990	93A-GC Cross Check arm chair 	18 1/8"	28 3/4"	28 1/2"	24 7/8"	33 3/8"			12 lbs.
		18 1/8"	28 3/4"	28 1/2"	24 7/8"	33 3/8"	0.8	15	12 lbs.
<i>Award(s):</i> ASID Award, 1992; ROSCOE Award, 1992; ID Magazine Gold Award, 1992; ICFE Award for Excellence, 1992; IBD Award (Silver), 1992; Premium Imperiale Award (Prince Takamatsu World Culture Award), 1992; Time Magazine, Best Design of 1992	93K Seat cushion replacement 						0.8	15	
		94L-GC Power Play club chair 	16"	23 1/2"	31 1/8"	30 1/8"	32 7/8"		
	94L-GC-K Power Play club chair 	16"	23 1/2"	31 1/8"	30 1/8"	32 7/8"	0.7	14	26 lbs.
		94K Seat cushion replacement 						0.7	14
	94LY-GC Off Side ottoman 			23 1/8"	23 3/8"	8 1/8"-13 1/8"			6 lbs.
	94LY-GC-K Off Side ottoman 			23 1/8"	23 3/8"	8 1/8"-13 1/8"	0.7	14	6 lbs.
	94YK Seat cushion replacement 						0.7	14	

Order Code	Ordering Information	Construction
------------	----------------------	--------------

<i>Example:</i> 93A-GC-K-K124/14		
93A	Cross Check arm chair	
GC	Clear Maple	
K	Seat cushion	
K1106/8	Spencer, Apricot	
<i>Example:</i> 93K-K1106/8		
93K	Cross Check chair seat cushion replacement	
K1175/3	Obi, Geta	

Finishes:
Clear Maple (suffix GC)

Seat cushion option:
To specify seat cushion, add "K" to end of pattern number and then list textile/leather pattern number.

Upholstery/COM information:
Prices shown include fabric or leather upholstery. Contact your Knoll representative for colors. Only approved KnollTextiles and Spinneybeck leathers may be ordered.

Customer's Own Material is available pending approval. For approval requirements, processing instructions and ordering information please see page 18.

Power Play note:
Power Play slats flex individually for added comfort. Recessed screws connect seat and arm.

Off Side note:
Ottoman has one pair of legs that, locked in upright position, create a slanted leg and foot rest (metal fasteners). Legs fold underneath for low foot rest or floor cushion.

Note:
The underside of each piece is embossed with the Knoll logo and Frank Gehry's signature.

Maintenance:
See pages 28-29.

Frame:
Constructed of hard white maple veneers in 2" wide, 1/8" thick strips. Laminated to 6 to 9-ply thickness with high-bonding urea glue. All wood grains run in same direction for resilience. Thermoset assembly glue provides structural rigidity minimizing the need for metal connectors, while allowing for ergonomic movement and flexibility. Backs on all chairs flex for added comfort.

To maximize tension compression, no assembly glues are used in woven seat: weaves flex in unison for spring-like comfort.

Cushions:
1" thick high resiliency foam for fish-shaped Cross Check cushion. 3/4" thick high resiliency foam for square Power Play and Off Side cushions. Cushions snap-lock underneath chair.

Glides:
Clear plastic with a matte frost finish.

Note:
The Gehry chairs are part of a collection. Please refer to Gehry tables on page 306.

Specify:

1. Pattern number
2. Seat cushion option
3. Textile selection

Seat cushion replacement, specify:

1. Pattern number
2. Textile selection

pattern no.	unuphol.	grades A	COM B	C	D	E	F	G	H	I	COL U	V	W	X	Y
93A-GC	\$6,275.														
93A-GC-K		6,863.	6,918.	6,970.	7,029.	7,074.	7,107.	7,169.	7,274.	7,354.	7,745.	7,954.	8,368.	8,454.	8,556.
93K-()		688.	745.	798.	856.	904.	933.	992.	1,100.	1,180.	1,570.	1,777.	2,192.	2,282.	2,383.
94L-GC	12,949.														
94L-GC-K		13,498.	13,549.	13,593.	13,646.	13,688.	13,718.	13,771.	13,870.	13,945.	14,358.	14,556.	14,952.	15,036.	15,138.
94K-()		648.	693.	743.	796.	836.	867.	919.	1,021.	1,092.	1,509.	1,706.	2,104.	2,187.	2,285.
94LY-GC	3,881.														
94LY-GC-K		4,403.	4,452.	4,496.	4,547.	4,583.	4,612.	4,663.	4,758.	4,830.	5,225.	5,413.	5,793.	5,877.	5,964.
94YK-()		619.	662.	709.	759.	798.	828.	880.	976.	1,045.	1,438.	1,627.	2,007.	2,089.	2,182.

Approved KnollTextiles Grades/Fabrics	Spinneybeck Leather
---------------------------------------	---------------------

A Alignment Beacon Bocce Chance Common Ground Commuter Cloth Crossroad Delite Dristi Hourglass Mariner Overture Prep Presto Soliloquy Sonnet Trophy Uni-Form	B continued Little Devil Ludlow Melody Mini Stitch Paradigm Pogo Prairie Prim # Radiance Ransom Roam Rush Hour Spark Spree Summit Sutton Synth Tabloid Utmost Venue Versa Vinyl Westwood Wide Angle Zipline	C continued Earthwork Echo Empire Stripe Emesh Entourage Essence Fibra Greenwich Hudson Hula Hoop Kora CR Lagos Legend CR Lore CR Magnolia Metro Milestone Moto CR Noble Palisade Panache CR Pullman Quark Roundtrip Sequin CR Sinclair Smart Spot On Star Struck Stepping Stones Swing Tower Grid	C continued Treble CR Zari CR	D Compass CR Coterie Eclat Weave Hologram Island Masquerade Menagerie Origins Tilden Woodland Zoom	E Aegean Cleo Demure Highland Ikat Stripe Katazome Kimono Mamba Marquee Midpoint Nature Walk Sherman Shima Tryst Vatera	F Atelier Biscayne Calais Cotton Velvet Cornaro Glider Icon Intrigue In Stitches Liberty Mod Plaid Rivington Topography Totem Tweed Frieze	G Alter Ego Arber Gibson Haze Kamani Melange Modern Tweed Petite Floral Serendipity Spencer Straie Stripe Ultrasuede Utrillo	H Arno Bavaria Catwalk Firefly Magritte Stretch Appeal	I Aswan Byron Diamond Days Dynamic Ita Jaipur Knoll Velvet Limani North Island Olema Piper Rutledge Sandis Tudor Vermeer Zimba	U Vicenza Volo	V Acqua Andes Embossed Tipped España Velluto Pelle	W Alaska Amazon Antique Forte Lucente Sabrina Umbria	X Ducale Ducale Velour	Y Cervo Copenhagen Distressed Gemma Lucca Marissa Riva
--	---	---	--	--	---	--	--	---	---	-----------------------------	--	--	-------------------------------------	--



Check with your KnollTextiles or Spinneybeck Representative for changes or additions.

Markus Jehs and Jürgen Laub

Jehs+Laub Lounge Collection, pedestal base



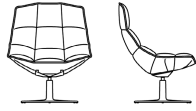
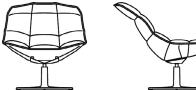















Designer(s):
Markus Jehs and Jürgen Laub,
2008



description	seat h	w	d	h	weight	type	textile fabric yds.	req. leather sq. ft.
JL1-P Jehs+Laub Lounge chair, fixed back, pedestal base	15"	33 1/4"	30 1/2"	38 1/2"	48 lbs.		3.1	50
								
JL1-PLT Jehs+Laub Lounge chair, fixed back, pedestal base, contrast leather welt option	15"	33 1/4"	30 1/2"	38 1/2"	48 lbs.	uphol.	3.1	50
						welt		4
JL2-P Jehs+Laub Lounge chair, articulating back, pedestal base	15"	33 1/4"	30 1/2"	38 1/2"	47 lbs.		3.1	50
								
JL2-PLT Jehs+Laub Lounge chair, articulating back, pedestal base, contrast leather welt option	15"	33 1/4"	30 1/2"	38 1/2"	47 lbs.	uphol.	3.1	50
						welt		4
JL3-P Jehs+Laub Ottoman, pedestal base		31"	22 1/2"	17 1/4"	27 lbs.		1.2	20
								
JL3-PLT Jehs+Laub Ottoman, pedestal base, contrast leather welt option		31"	22 1/2"	17 1/4"	27 lbs.	uphol.	1.2	20
						welt		3

Order Code	Ordering Information	Construction
<i>Example:</i> JL2-PLT-C-K1080/8-VO939	<i>Base finishes:</i> Polished Aluminum (suffix AP) Textured Black paint (suffix TB)	<i>Shell:</i> Molded and reinforced urethane.
JL2	Jehs+Laub Lounge chair, articulating back	
PLT	Pedestal base with contrast leather trim	<i>Base:</i> Pedestal base is available with polished aluminum finish and wire base is available with polished chrome finish, both bases are also available with textured black paint finish.
AP	Polished Aluminum	<i>Upholstery:</i> Polyurethane foam with polyester-fiber backing. Hidden seam tufting eliminates the need for traditional pulls or buttons. A perimeter welt is standard on both chair and ottoman and is available as a self welt (same material) or as a contrasting leather welt. Please specify pattern number with LT suffix, for contrasting welt, and add appropriate leather upcharge for total list price of the piece. Leather welt option is available on textile and leather upholstery.
K1080/8	Rivington, Parchment	
VO939	Volo, Talc	<i>Maintenance:</i> See pages 28-29.
		<i>Note:</i> The KnollStudio logo and signature of Markus Jehs and Jürgen Laub are located on the underside of the chair and ottoman.
		<i>Construction:</i> The Jehs+Laub Lounge Collection with pedestal base is Greenguard certified.
	<i>Customer's Own Material</i> is available pending approval. For approval requirements, processing instructions and ordering information please see page 18.	
<i>Specify:</i>		
1. Pattern number		
2. Return to center mechanism, option		
3. Base finish selection		
4. Textile selection		
5. Contrast leather trim selection, upcharge applies		

pattern no.	grades A	COM B	C	D	E	F	G	H	I	COL U	V	W	X	Y
JL1-P-(-)(-)(-)	\$4,730.	\$4,810.	\$4,884.	\$4,966.	\$5,035.	\$5,082.	\$5,167.	\$5,326.	\$5,442.	\$6,678.	\$6,932.	\$7,451.	\$7,556.	\$7,681.
JL1-PLT-(-)(-)(-)(-)	4,730.	4,810.	4,884.	4,966.	5,035.	5,082.	5,167.	5,326.	5,442.	6,678.	6,932.	7,451.	7,556.	7,681.
upchg, welt										809.	938.	1,194.	1,250.	1,312.
JL2-P-(-)(-)(-)	5,758.	5,839.	5,913.	5,996.	6,063.	6,112.	6,198.	6,355.	6,471.	7,967.	8,222.	8,740.	8,847.	8,972.
JL2-PLT-(-)(-)(-)(-)	5,758.	5,839.	5,913.	5,996.	6,063.	6,112.	6,198.	6,355.	6,471.	7,967.	8,222.	8,740.	8,847.	8,972.
upchg, welt										809.	938.	1,194.	1,250.	1,312.
JL3-P-(-)(-)	2,758.	2,789.	2,817.	2,849.	2,877.	2,895.	2,928.	2,989.	3,036.	3,275.	3,376.	3,582.	3,628.	3,676.
JL3-PLT-(-)(-)(-)(-)	2,758.	2,789.	2,817.	2,849.	2,877.	2,895.	2,928.	2,989.	3,036.	3,275.	3,376.	3,582.	3,628.	3,676.
upchg, welt										656.	785.	1,043.	1,098.	1,162.

	Approved KnollTextiles Grades/Fabrics	Spinneybeck Leather
<i>Return to center mechanism:</i> Optional return to center mechanism allows for 360° swivel movement and returns to a center position when not engaged.	A Common Ground Crossroad Delite Dristi Hourglass Mariner Overture Presto Sonnet Uni-Form	U Vicenza  Volo 
To specify return to center mechanism, add suffix RC following the parent pattern number.	B cont. Ransom Spark Summit Synth Tinge Venue Vinyl Westwood	X Ducale Velour Y Cervo  Copenhagen  Distressed  Marissa  Riva  Saddle  Torello
<i>Glides:</i> Nylon glides, natural.	C Atlas Circa Classic Boucle Enmesh Palisade Pullman Sahara Sequin CR Spot On Star Struck Swing	V Acqua  Andes  Embossed Tipped España  Maremma  Velluto Pelle  W Alaska  Antique  Forte  Sabrina  Umbria
<i>Control:</i> 360° swivel mechanism.	E Aegean Demure Highland Whip F Atelier Calais Cotton Velvet Cornaro Rivington Soon Tweed Frieze	H Alter Ego Haze Melange Modern Tweed Petite Floral Ultrasuede I Arno  Catwalk Magritte Stretch Appeal L Knoll Velvet Tudor

Check with your KnollTextiles or Spinneybeck Representative for changes or additions.

Markus Jehs and Jürgen Laub

Jehs+Laub Lounge Collection, wire base

Designer(s):
Markus Jehs and Jürgen Laub,
2008

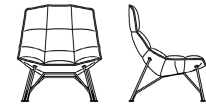

description	seat h	w	d	h	weight	type	textile fabric yds.	req. leather sq. ft.
JL1-W Jehs+Laub Lounge chair, fixed back, wire base	14 1/2"	33 1/4"	30 1/2"	38"	43 lbs.		3.1	50
JL1-WLT Jehs+Laub Lounge chair, fixed back, wire base, contrast leather welt option	14 1/2"	33 1/4"	30 1/2"	38"	43 lbs.	uphol. welt	3.1	50 4
JL2-W Jehs+Laub Lounge chair, articulating back, wire base	14 1/2"	33 1/4"	30 1/2"	38"	42 lbs.		3.1	50
JL2-WLT Jehs+Laub Lounge chair, articulating back, wire base, contrast leather welt option	14 1/2"	33 1/4"	30 1/2"	38"	42 lbs.	uphol. welt	3.1	50 4
JL3-W Jehs+Laub Ottoman, wire base		31"	22 1/2"	16 3/4"	22 lbs.		1.2	20
JL3-WLT Jehs+Laub Ottoman, wire base, contrast leather welt option		31"	22 1/2"	16 3/4"	22 lbs.	uphol. welt	1.2	20 3

Order Code	Ordering Information	Construction
<i>Example:</i> JL2-PLT-C-K1080/8-VO939	<i>Base finishes:</i> Polished Chrome (suffix C) Textured Black paint (suffix TB)	<i>Shell:</i> Molded and reinforced urethane.
JL2	Jehs+Laub Lounge chair, articulating back	
PLT	Pedestal base with contrast leather trim	<i>Base:</i> Pedestal base is available with polished aluminum finish and wire base is available with polished chrome finish, both bases are also available with textured black paint finish.
C	Polished Chrome	<i>Upholstery:</i> Polyurethane foam with polyester-fiber backing. Hidden seam tufting eliminates the need for traditional pulls or buttons. A perimeter welt is standard on both chair and ottoman and is available as a self welt (same material) or as a contrasting leather welt. Please specify pattern number with LT suffix, for contrasting welt, and add appropriate leather upcharge for total list price of the piece. Leather welt option is available on textile and leather upholstery.
K1080/8	Rivington, Parchment	
VO939	Volo, Talc	
<i>Specify:</i>	<i>Upholstery/COM information:</i> Prices shown include fabric or leather upholstery. Contact your Knoll representative for colors. Only approved KnollTextiles and Spinneybeck leathers may be ordered.	
	Customer's Own Material is available pending approval. For approval requirements, processing instructions and ordering information please see page 18.	
	<i>Maintenance:</i> See pages 28-29.	
	<i>Note:</i> The KnollStudio logo and signature of Markus Jehs and Jürgen Laub are located on the underside of the chair and ottoman.	
	The Jehs+Laub Lounge Collection with pedestal base is Greenguard certified.	

pattern no.	grades A	COM B	C	D	E	F	G	H	I	COL U	V	W	X	Y
JL1-W-(-)(-)	\$4,730.	\$4,810.	\$4,884.	\$4,966.	\$5,035.	\$5,082.	\$5,167.	\$5,326.	\$5,442.	\$6,678.	\$6,932.	\$7,451.	\$7,556.	\$7,681.
JL1-WLT-(-)(-)(-) upchg, welt	4,730.	4,810.	4,884.	4,966.	5,035.	5,082.	5,167.	5,326.	5,442.	6,678. 809.	6,932. 938.	7,451. 1,194.	7,556. 1,250.	7,681. 1,312.
JL2-W-(-)(-)	5,758.	5,839.	5,913.	5,996.	6,063.	6,112.	6,198.	6,355.	6,471.	7,967.	8,222.	8,740.	8,847.	8,972.
JL2-WLT-(-)(-)(-) upchg, welt	5,758.	5,839.	5,913.	5,996.	6,063.	6,112.	6,198.	6,355.	6,471.	7,967. 809.	8,222. 938.	8,740. 1,194.	8,847. 1,250.	8,972. 1,312.
JL3-W-(-)(-)	2,758.	2,789.	2,817.	2,849.	2,877.	2,895.	2,928.	2,989.	3,036.	3,275.	3,376.	3,582.	3,628.	3,676.
JL3-WLT-(-)(-)(-) upchg, welt	2,758.	2,789.	2,817.	2,849.	2,877.	2,895.	2,928.	2,989.	3,036.	3,275. 656.	3,376. 785.	3,582. 1,043.	3,628. 1,098.	3,676. 1,162.

Return to center mechanism:	Approved KnollTextiles Grades/Fabrics				Spinneybeck Leather	
Optional return to center mechanism allows for 360° swivel movement and returns to a center position when not engaged.	A Common Ground Crossroad Delite Dristi Hourglass Mariner Overture Presto Sonnet Uni-Form	B continued Ransom Spark Summit Synth Tinge Venue Vinyl Westwood	E Aegean Demure Highland Whip	G Alter Ego Haze Melange Modern Tweed Petite Floral Ultrasuede	U Vicenza # Volo #	X Ducale Velour
To specify return to center mechanism, add suffix RC following the parent pattern number.	C Atlas Circa Classic Boucle Enmesh Palisade Pullman Sahara Sequin CR Spot On Star Struck Swing	F Atelier Calais Cotton Velvet Cornaro Rivington Soon Tweed Frieze	H Arno # Catwalk Magritte Stretch Appeal	V Acqua # Andes # Embossed Tipped España # Maremma # Velluto Pelle #	Y Cervo # Copenhagen # Distressed # Marissa # Riva # Saddle # Torello	
<i>Glides:</i> Nylon glides, natural.	B Calypso Cameo Chroma Diva Ferry Helios Journey Keaton Knoll Felt Knoll Hopsack Little Devil Ludlow Prairie		I Knoll Velvet Tudor	W Alaska # Antique # Forte # Sabrina # Umbria		
<i>Control:</i> 360° swivel mechanism.					<i>Check with your KnollTextiles or Spinneybeck Representative for changes or additions.</i>	

Florence Knoll Lounge Seating

Designer(s):
Florence Knoll, 1954

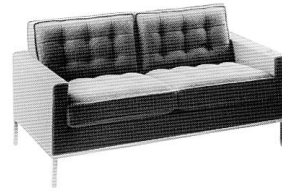

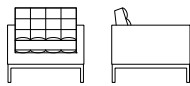
description	seat h	arm h	w	d	h	textile fabric yds.	req. leather sq. ft.	weight
1205S1 Lounge chair 	17 1/2"	23 1/2"	32 1/4"	32 1/4"	31 1/4"	6.75	97	70 lbs.
	17 1/2"	23 1/2"	32 1/4"	32 1/4"	31 1/4"	6.75	97	70 lbs.

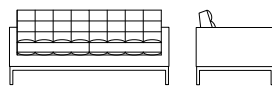

1205S2 Settee 	17 1/2"	23 1/2"	62 1/2"	32 1/4"	31 1/4"	11.8	145	101 lbs.
	17 1/2"	23 1/2"	62 1/2"	32 1/4"	31 1/4"	11.8	145	101 lbs.

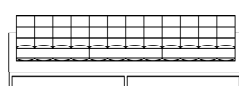
1205S3 Sofa 	17 1/2"	23 1/2"	90 1/2"	32 1/4"	31 1/4"	15.7	193	166 lbs.
	17 1/2"	23 1/2"	90 1/2"	32 1/4"	31 1/4"	15.7	193	166 lbs.

2530Y2C Two Seater Bench 			36 1/4"	19 1/2"	16 1/4"	1.6	20	29 lbs.

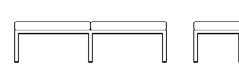
2530Y3C Three Seater Bench 			60 1/4"	19 1/2"	16 1/4"	2.5	32	47 lbs.

pattern no.	grades A	COM B	C	D	E	F	G	H	I	COL U	V	W	X	Y
1205-C-S1	\$7,615.	\$7,793.	\$7,960.	\$8,147.	\$8,297.	\$8,405.	\$8,594.	\$8,948.	\$9,209.	\$11,133.	\$11,819.	\$13,219.	\$13,511.	\$13,851.
1205-CO-S1	7,762.	7,941.	8,108.	8,295.	8,447.	8,554.	8,741.	9,095.	9,358.	11,281.	11,967.	13,366.	13,660.	13,998.

1205-C-S2	12,169.	12,445.	12,712.	12,999.	13,237.	13,410.	13,702.	14,253.	14,664.	17,326.	18,360.	20,454.	20,887.	21,396.
1205-CO-S2	12,393.	12,667.	12,936.	13,225.	13,462.	13,633.	13,925.	14,477.	14,888.	17,553.	18,584.	20,677.	21,110.	21,620.

1205-C-S3	16,834.	17,187.	17,523.	17,887.	18,191.	18,410.	18,779.	19,476.	20,000.	23,854.	25,225.	28,016.	28,592.	29,269.
1205-CO-S3	17,135.	17,490.	17,822.	18,191.	18,492.	18,710.	19,080.	19,779.	20,302.	24,157.	25,526.	28,317.	28,894.	29,570.

2530Y2C	3,738.	3,787.	3,830.	3,884.	3,927.	3,957.	4,010.	4,107.	4,180.	4,406.	4,582.	4,937.	5,014.	5,100.
----------------	--------	--------	--------	--------	--------	--------	--------	--------	--------	--------	--------	--------	--------	--------

2530Y3C	6,174.	6,263.	6,349.	6,442.	6,516.	6,570.	6,664.	6,842.	6,968.	7,228.	7,508.	8,080.	8,198.	8,342.
----------------	--------	--------	--------	--------	--------	--------	--------	--------	--------	--------	--------	--------	--------	--------

Order Code

<i>Example:</i>	1205-CO-S3-K349/4
1205	Florence Knoll Lounge
CO	Satin Chrome
S3	Sofa
K349/4	Alignment, Paprika

Note:
Florence Knoll lounge seating is part of a collection. Please refer to Florence Knoll executive collection, conference and low tables beginning on page 310.

Specify:

1. Pattern number
2. Base finish selection (chair, settee and sofa only)
3. Textile selection

Ordering Information

Base finish options:
Polished Chrome (suffix C)
Satin Chrome (suffix CO) Not available on bench

Upholstery/COM information:
Prices shown include fabric or leather upholstery. Contact your Knoll representative for colors. Only approved KnollTextiles and Spinneybeck leathers may be ordered.

Customer's Own Material is available pending approval. For approval requirements, processing instructions and ordering information please see page 18.

Note:
Designer signature and KnollStudio logo are stamped into the base of the frame.

Cal 133 Fire Code:

The Florence Knoll Lounge collection complies with the California Technical Bulletin 133 standard if upholstered in Cal 133 approved upholstery. Specify suffix -C at end of pattern number and suffix -133 at end of textile selection. Upcharge applies, see page 18.

Maintenance:
See pages 28-29.

Note:
The Florence Knoll Lounge Collection is Greenguard certified.

Construction

Chair, Settee and Sofa:
Inner frame solid wood. Exposed metal frame and legs heavy gauge tubular steel in polished or satin chrome finish.

Bench:
Upholstered seat attached to exposed metal frame. Heavy gauge steel in a polished chrome finish. Seat cushion is permanently attached to frame. Large bench consists of 2 separate 30" cushions. Frame only available in polished chrome.

Upholstery:
Seat suspension with No-Sag springs. Arm, seat and back cushions variable density foam. Seat and back covering is fully welted and tufted. Pieces upholstered in leather have matching buttons, pieces upholstered in fabric do not have buttons.

Glides:
Bench and lounge collection have chrome-plated adjustable glides used for levelling.

Approved KnollTextiles Grades/Fabrics

A Alignment † Beacon Bocce Chance Common Ground Commuter Cloth Crossroad Delite Dristi Hourglass Mariner Monarch † Overture Presto † * * Sonnet Trophy Uni-Form	B continued Grande Helios Journey Keaton Knoll Felt † Knoll Hopsack † Little Devil Ludlow Melody Prairie Radiance Ransom Spark † Spree Summit Trophy Tinge Venue Westwood	C Atlas Circa Classic Boucle Entourage Greenwich Hula Hoop Lagos Lore CR Palisade Pullman Sahara Sequin CR	C continued Spot On Stepping Stones Swing * * Tilden D Eclat Weave Hologram Masquerade Woodland Zoom	E Aegean Demure Highland Katazome Mamba Whip F Atelier Calais Cotton Velvet Cornaro * * Rivington Soon Topography	G Alter Ego Haze Melange Modern Tweed Petite Floral Spencer Ultrasuede † H Arno Magritte I Cato Dynamic Knoll Velvet Tudor Vermeer	U Vicenza † Volo † V Acqua † Andes † Embossed Tipped España † Velluto Pelle † W Alaska † Amazon † Antique † Forte † Lucente Sub Available for Cal 133 upholstery. On White On White * *Fabric will be railroaded	Y Cervo Copenhagen † Distressed † Marissa † Riva † Saddle †
---	---	---	--	---	---	---	--

Check with your KnollTextiles or Spinneybeck Representative for changes or additions.

Florence Knoll

Relaxed Lounge Seating

Designer(s):
Florence Knoll, 1954

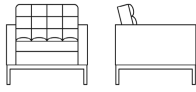
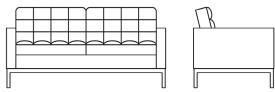
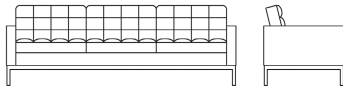

description	seat h	arm h	w	d	h	textile fabric yds.	req. leather sq. ft.	w
1206S1 Relaxed Lounge Chair	18 1/4"	23 1/2"	32 1/4"	32 1/4"	31 1/4"	6.9 yards	125 sq ft	70
								
1206S2 Relaxed Settee	18 1/4"	23 1/2"	63"	35"	31 1/4"	10.9 yards	182 sq ft	125
								
1206S3 Relaxed Sofa	18 1/4"	23 1/2"	91"	35"	31 1/4"	13.8 yards	240 sq ft	177
								



pattern no.	grade A	COM B	C	D	E	F	G	H	I	COL U	V	W	X	Y
1206-C-S1	\$6,285.	\$6,431.	\$6,569.	\$6,724.	\$6,847.	\$6,937.	\$7,092.	\$7,384.	\$7,599.	\$9,187.	\$9,753.	\$10,910.	\$11,150.	\$11,431.
1206-C-S2	10,042.	10,269.	10,490.	10,728.	10,923.	11,066.	11,307.	11,762.	12,101.	14,299.	15,152.	16,879.	17,237.	17,657.
1206-C-S3	13,893.	14,184.	14,460.	14,761.	15,012.	15,192.	15,497.	16,073.	16,505.	19,686.	20,818.	23,119.	23,594.	24,154.

Order Code	Ordering Information	Construction
<i>Example:</i> 1206-C-S3-K349/4	<i>Base finish options:</i> Polished Chrome (suffix C)	<i>Chair, Settee and Sofa:</i> Inner frame solid wood. Exposed metal frame and legs heavy gauge tubular steel in polished chrome finish.
1206 Florence Knoll Relaxed Lounge	<i>Upholstery/COM information:</i> Prices shown include fabric or leather upholstery. Contact your Knoll representative for colors. Only approved KnollTextiles and Spinneybeck leathers may be ordered.	Sofa has four legs (versus six on the standard version). Relaxed back cushions are attached with a zipper as opposed to sewn.
C Polished Chrome	<i>Maintenance:</i> See pages 28-29.	<i>Upholstery:</i> Seat suspension with springs. Arm, seat and back cushions multi-density foam. Seat and back covering is tufted and covered with polyester fiberfill to enhance comfort. Pieces upholstered in leather have matching buttons. Pieces upholstered in fabric do not have buttons. *Due to differing textile thicknesses, dimensions may vary by +/- 1/2".
S3 Sofa	Customer's Own Material is available pending approval. For approval requirements, processing instructions and ordering information please see page 18.	<i>Glides:</i> Lounge collection has chrome-plated adjustable glides used for leveling.
K349/4 Alignment, Paprika		

Approved KnollTextiles Grades/Fabrics	Spinneybeck Leather
A Alignment Beacon Bocce Chance Common Ground Commuter Cloth Crossroad Delite Dristi Hourglass Mariner Monarch Overture Presto * * Sonnet Trophy Uni-Form	U Vicenza Volo V Acqua Andes Embossed Tipped España Velluto Pelle W Alaska Amazon Antique Forte Lucente Sabrina Umbria * Will be produced with matching buttons rather than tufted **Fabric will be railroaded
B continued Grande Helios Journey Keaton Knoll Felt Knoll Hopsack Little Devil Ludlow Melody Prairie Radiance Ransom Spark Spree Summit Synth Tinge Venue Westwood	Y Cervo Copenhagen Distressed Marissa Riva Saddle
C Atlas Circa Classic Boucle Entourage Greenwich Hula Hoop Lagos Lore CR Palisade Pullman Sahara Sequin CR	H Arno Magritte
C continued Spot On Stepping Stones Swing * * Tilden	I Cato Dynamic Knoll Velvet Tudor Vermeer
D Eclat Weave Hologram Masquerade Woodland Zoom	G Alter Ego Haze Melange Modern Tweed Petite Floral Spencer Ultrasuede
E Aegean Demure Highland Katazome Mamba Whip	F Atelier Calais Cotton Velvet Cornaro * * Rivington Soon Topography

Check with your KnollTextiles or Spinneybeck Representative for changes or additions.



description	w	d	textile fabric yds.	type
KSP1 Lumbar pillow 	20"	10.5"	0.4	same upholstery
KSP1S Lumbar pillow	20"	10.5"	0.4	combination upholstery
KSP2 Throw pillow 	16"	16"	0.4	same upholstery
KSP2S Throw pillow	16"	16"	0.4	combination upholstery
KSP3 Large throw pillow 	20"	20"	0.7	same upholstery
KSP3S Large throw pillow	20"	20"	0.7	combination upholstery

pattern no.	A	B	C	D	E	F	G	H	I
KSP1-()	\$186.	\$194.	\$204.	\$213.	\$219.	\$226.	\$235.	\$254.	\$265.
KSP1S-()-()	205.	214.	223.	231.	240.	244.	255.	272.	286.
KSP2-()	234.	243.	253.	260.	268.	274.	285.	301.	315.
KSP2S-()-()	258.	266.	277.	286.	292.	296.	308.	326.	337.
KSP3-()	372.	390.	407.	424.	441.	451.	470.	504.	531.
KSP3S-()-()	412.	431.	445.	465.	479.	492.	509.	543.	571.

Order Code	Ordering Information	Construction
<i>Example:</i> KSP1-K1174/6	<i>Upholstery/COM information:</i> Prices shown include fabric upholstery only. Contact your Knoll representative for colors.	<i>Fill:</i> Made from 100% recycled polyester.
KSP1 Lumbar pillow, same upholstery		
K1174/6 Kimono, Sakura	<i>Note:</i> For pillows with combination upholstery, list price is the highest of the two grades.	<i>Ticking:</i> 100% cotton.
<i>Example:</i> KSP3S-K1155/6-K1021/2		
KSP3S Large throw pillow, combination upholstery		
K1155/6 Jaipur, Ginger		
K1021/2 Ultrasuede, Sand		

Specify:

1. Pattern number
2. Upholstery selection
3. Upholstery selection for split upholstery







Approved KnollTextiles Grades/Fabrics

A Alignment Beacon Bocce Cat's Cradle Chance Common Ground Commuter Cloth Crossroad Delite Dristi Heavy Metal Hourglass Mariner Monarch Overture Prep Presto Soliloquy Sonnet Trophy Uni-Form	B continued Little Devil Ludlow Melody Mini Stitch Nonchalant CR Paradigm Pogo Prairie Prim Radiance Ransom Roam Rush Hour Spark Spree Summit Sutton Synth Tabloid Tinge Utmost Venue Versa Westwood Wide Angle Yeni Zipline	C continued Empire Stripe Enmesh Entourage Essence Fable CR Fibra Greenwich Hudson Hula Hoop Kaleidoscope Kora CR Lagos Lore CR Magnolia Metro Milestone Moto CR Noble Panache CR Pullman Quark Roundtrip Sahara Sequin CR Sinclair Spectator Spot On Star Struck Stepping Stones Swing Tight Rope Tilden Tower Grid Treble CR Wit Zari CR	D Coterie Eclat Weave Hologram Island Masquerade Menagerie Origins Woodland Zoom	E Aegean Cleo Demure Highland Ikat Stripe Juno Katazome Kimono Mamba Marquee Meroe Midpoint Nature Walk Sherman Shima Spot On Vatera Whip	F Atelier Biscayne Calais Cotton Velvet Cornaro Glider Intrigue In Stitches Jasmine Liberty Mod Plaid Rivington Soon Topography Totem	G Alter Ego Arber Gibson Haze Kamani Melange Modern Tweed Petite Floral Serendipity Spencer Straie Stripe Ultrasuede Utrillo	H Arno Bavaria Catwalk Constance Firefly Magritte Stretch Appeal	I Aswan Cato Diamond Days Dynamic Jaipur Knoll Velvet Olema Piper Rutledge Sandis Tudor Vermeer Zimba
---	--	---	--	--	---	--	--	---

Check with your KnollTextiles Representative for changes or additions.



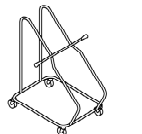

Antti Kotilainen

CHIP Chair and Barstool

	description	seat h	arm h, max	w	d	h	weight
<i>Designer(s):</i> Antti Kotilainen, 2002 <i>Award(s):</i> Good Design Award, 2002	23C CHIP armless chair	17 3/4"		20"	19 3/4"	31"	7 lbs.
							
	23CK CHIP armless chair, seat pad	17 3/4"		20"	19 3/4"	31"	8 lbs.
							
	23A CHIP arm chair	17 3/4"	26 1/4"	21 1/2"	19 3/4"	31"	10 lbs.
							
	23AK CHIP arm chair, seat pad	17 3/4"	26 3/4"	21 1/2"	19 3/4"	31"	10 lbs.
							
	23CH-C CHIP Barstool, bar height, chrome base	29 1/2"		19 1/2"	17 1/2"	33 3/4"	10 lbs.
							
	23DOLLY Dolly for 20 chairs			23 3/8"	32 3/4"	34 3/8"	24 lbs.
							
	23GA Ganging mechanism						
							



pattern no.	unuphol.	seat pad
23C-()-C 	\$827.	
23CK-N-()-C-()		1,334.
23A-()-C	1,188.	
23AK-N-()-C-()		1,744.
23CH-()-C	874.	
23DOLLY	1,733.	
23GA	73.	

Order Code	Ordering Information	Construction
<i>Example:</i> 23CK-N-WV-C-D893	<i>Shell Finishes:</i>  Birch (suffix FMB) Blue (suffix BU) Black (suffix BL) Oak (suffix FMO) Red (suffix RD)  Grey (suffix SL)  White (suffix WV)	<i>Chair:</i> Constructed of melamine covered molded birch on a chrome plated base. <i>Note:</i> The backrest mounts will always be in the silver grey powder paint, even on a chair with chrome frame.
WV White shell		
C Chrome base		
D893 Divina 893 fabric		
<i>Example:</i> 23CH-BU-C	<i>Frame Finishes:</i>  Chrome (suffix C)	<i>Seat pad:</i> CHIP chair with seat pad does not stack. Seat pad is a dacron covered piece of plywood attached to the chair seat. Seat pad is permanently attached to seat by discrete screws not visible from top of chair. Upholstery available in Gabriel fabrics: Event, Fame, and Gaja . Please contact your KnollStudio sales representative for samples.
23CH Chip barstool		
BU Blue shell		
C Chrome base		

Specify:

1. Pattern number
2. Shell finish
3. Frame finish
4. Textile selection

Approved Textiles
<i>Event (E):</i> 100% polyester crepe fabric. It is a synthetic fabric suitable for environments with special requirements regarding cleaning.
<i>Fame (F):</i> A unique woollen upholstery fabric with a wearability of 200,000 Martindale. Extra soft and stretchable with an elegant and vibrant color scale.
<i>Gaja (G):</i> Non directional crepe weave made from 100% pure New Wool from New Zealand with anti-slip properties.
<i>Please contact your KnollStudio representative for colorways, color codes and samples.</i>

Barstool:
Constructed of melamine covered molded birch on a chrome plated base. Foot rest is 11 1/2" from the floor.

Stackability:
Chair
CHIP stacks 12 on the floor. Height of 12 CHIP chairs measures 46" high.

Barstool
CHIP Barstool stacks 6 high on the floor.

Transportation Dolly:
Zinc coated dolly allows CHIP arm and armless chairs to stack 20 high. Height of dolly with 20 CHIP chairs, fully loaded is 63". Empty dollies can be stacked 5 high.

Ganging Mechanism:
The easy to attach and detach mechanism links the back of the chair frames. The mechanism is composed of translucent polypropylene. Can be used for both arm and armless chairs.

Marc Krusin

Guest Seating Collection

Side Chair with Arms

Designer(s):
Marc Krusin, 2011

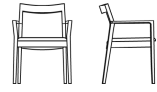

description	seat h	arm h	w	d	h	textile fabric yds.	required leather sq. ft.	weight	finish
MK01A Krusin arm chair	18 1/2"	24 1/2"	23 1/2"	21 3/4"	30 1/2"	0.8	14.5	14 lbs.	beech finish
	18 1/2"	24 1/2"	23 1/2"	21 3/4"	30 1/2"	0.8	14.5	14 lbs.	ash or oak finish
	18 1/2"	24 1/2"	23 1/2"	21 3/4"	30 1/2"	0.8	14.5	14 lbs.	walnut finish
MK01R Seat basket replacement for side chair						0.8	14.5		
MK01RCN Woven rush seat basket replacement for side chair									light kraft

pattern no.	grades A	COM B	C	D	E	F	G	H	I	COL U	V	W	X	Y
MK01A-()	\$1,176.	\$1,193.	\$1,214.	\$1,237.	\$1,251.	\$1,263.	\$1,284.	\$1,325.	\$1,354.	\$1,571.	\$1,628.	\$1,774.	\$1,804.	\$1,840.
MK01A-(A101, O_)	1,454.	1,472.	1,491.	1,512.	1,530.	1,541.	1,562.	1,603.	1,631.	1,850.	1,904.	2,051.	2,081.	2,117.
MK01A-(AW)	1,791.	1,809.	1,828.	1,850.	1,866.	1,879.	1,899.	1,940.	1,969.	2,186.	2,242.	2,389.	2,419.	2,454.
MK01R	343.	361.	381.	402.	418.	431.	451.	492.	521.	727.	782.	929.	958.	994.
MK01RCN	443.	0.	0.	0.	0.	0.	0.	0.	0.	0.	0.	0.	0.	0.

Order Code

<i>Example:</i>	MK01A-BE-K1207/17
MK01A	Krusin arm chair
BE	Ebonized
K1207/17	Knoll Felt, Pewter

Specify:

1. Pattern number
2. Woven rush seat, optional
3. Finish selection
4. Textile selection

Ordering Information:

Ash:
White Ash (suffix A101)

Beech frame stains:
Beech (suffix B311)
Bronzed Cherry (suffix B312A)
Burnt Walnut (suffix B313)
Deep Red Mahogany (suffix B328)
Ebonized (suffix BE)
Light Cherry (suffix B315)
Light Walnut (suffix B411)
Medium Cherry (suffix B319)
Medium Red Mahogany (suffix BR)
Medium Walnut (suffix B323)
Natural Beech (suffix BN)
Warm Brown Walnut (J)

Oak:
Ebonized Oak (suffix OE)
Fumed Oak (suffix OF)
Grey Oak, White Ceruse (suffix OGW)
Grey Oak, Black Ceruse (suffix OGB)
Natural Oak (suffix ON)

Walnut:
American Walnut (suffix AW)

Optional Woven Seat:
An optional woven paper rush seat is available at an upcharge, from grade A pricing, of \$295 for side chairs and \$331 for lounge chairs. Place suffix CN between parent pattern number and wood finish suffix.

Example:MK01A-CN-BE

Upholstery/COM information:
List prices shown include fabric or leather upholstery. Contact your Knoll representative for colors. Only approved KnollTextiles and Spinneybeck leathers may be ordered.

Customer's Own Material is available pending approval. For approval requirements, processing instructions and ordering information please see page 18.

KnollStudio natural wood finishes:
The Krusin Collection of guest seating features a low sheen, Greenguard approved, urethane finish. This finish, available on Ash, Oak, and Walnut delivers the tactility of natural wood while providing a durable matte finish.

Ash and Oak feature a unique staining process that replicate traditional cereused finishes.

KnollStudio Beech wood finishes:
KnollStudio Beech finishes complement a large variety of KnollStudio veneer and Knoll Office veneer finishes. To select correct complementary finish, please refer to KnollStudio Wood Finish Matrix on page 25. If no complementary finish is available, please refer to custom finish policy below.

Custom finishes:
Complementary finishes to any KnollStudio or Knoll Office wood finish are available at no upcharge. To complement non-Knoll wood veneer or lumber finishes, a one-time, non-negotiable net upcharge of \$662 applies. Re-orders are at no upcharge. Please contact your KnollStudio representative, dealer or Customer Service associate for complete custom finish information and Order Code. Minimum order quantity for any custom finish order: 4 chairs.

Certified Wood:
Chairs manufactured using FSC certified hardwoods are available through Custom Product Development. Extended leadtime and upcharge apply.

Maintenance:
See pages 28-29

Note:
The Krusin Collection chairs are Greenguard certified in all wood finishes.

Cal 133 Fire Code #:
The Krusin Side Chairs comply with the California Technical Bulletin 133 standard if upholstered in Cal 133 approved upholstery. Specify suffix -C at end of pattern number and suffix -133 at end of textile selection. Upcharge applies, see page 18.

Construction

Frame:
Select American and European hard wood frames. Dowel and mortise and tenon construction, steam bent top rail. A bent laminate upholstered inset back is available. The back of inset features horizontal grain direction.

Upholstered Seat:
High density, polyurethane foam used in all upholstered areas. Elastic seat belt suspension.

Woven Rush Seats:
A woven natural paper rush seat is available on side and lounge chairs. Not available on chairs with inset back upholstery. Paper rush is a natural, uncoated material.

KnollStudio will not warrant soiled or stained woven seats. A one year warranty will cover woven seats for manufacturer's defects.

Seat basket replacements:
Upholstered and woven seats sit on chair frame. Screws lock basket in place for easy installation or removal.

Finish:
Beech, Catalyzed lacquer protective coating. Hand applied final wax coating. Ash, Oak, and Walnut, urethane protective coating. Hand applied final wax coating.

Glides:
Chairs feature nylon glides.

Approved KnollTextiles Grades/Fabrics

A Alignment # Beacon Bocce # Cat's Cradle # Chance Common Ground # Commuter Cloth # Crossroad Delite Dristi Foil Rap Heavy Metal Hourglass Mariner Monarch Overture Prep # Presto # Soliloquy Sonnet Trophy # Uni-Form	B continued Ferry Forza Gala II Grande Grandview Holbrook Journey Keaton Knoll Felt Knoll Hopsack Little Devil Ludlow Melody Mini Stitch # Paradigm Petat Pusher Prairie Prim # Radiance Ransom Roam Rush Hour Spark # Spree # Summit Sutton Synth Tabloid Tinge Utmost Venue # Versa # Chroma # Chronicle Close Knit Digital Tape Diva Dovetail Fast Forward	C Atlas Axiom Baxter Cairo Charm Circa Classic Boucle Dahlia CR * Decade Durand Earthwork # Echo Empire Stripe Emmesh # Entourage # Essence Fable CR * Fibra Greenwich Hudson Hula Hoop Kaleidoscope CR Kaya CR Kora CR Lagos Legend CR Lore CR Magnolia Metro Milestone Moto CR Noble Palisade Panache CR Pullman Quark Roundtrip # Sahara Sequin CR	C continued Sinclair Smart Spectator # Spot On Star Struck Stepping Stones Swing Tight Rope Tilden * Tower Grid Trebble CR Wit Zari CR Zen Wave	D Compass CR Coterie Eclat Weave Hologram In The Loop Island Kabuki Masquerade Menagerie Origins Woodland Zoom	E Aegean Cleo Highland Ikat Stripe Juno Katazome Kimono	E continued Mamba Marquee Midpoint Sherman Shima Tryst Vatera Whip	F Atelier Biscayne Calais Cotton Velvet Cornaro Glider Icon Intrigue In Stitches Liberty Mod Plaid Rivington Soon Topography Totem Tweed Frieze	G continued Modern Tweed Serendipity Spencer Straie Stripe Ultrasuede Utrillo	H Arno Bavaria Catwalk Constance Firefly Magritte Stretch Appeal	I Aswan Byron Cato Cummings Diamond Days Dynamic Ita Jaipur Knoll Velvet Limani Mepal North Island Olema Piper Rutledge Sandis Tudor Vermeer Zimba	U Vicenza # Volo #	V Acqua # Andes # Embossed Tip # España # Hand Tipped Maremma # Velluto Pelle #	W Alaska # Amazon # Antique # Derby Forte # Lucente Sabrina # Nbrtrp approved for inset back.	X Ducale * # Ducale Velour #	Y Cervo * # Copenhagen # Distressed # Gemma * Lucca * Marissa # Portofino Riva # Saddle Torello * #
---	---	---	--	---	---	---	--	--	--	--	---------------------------------	---	--	---	--

Spinneybeck Leather

U Vicenza # Volo #	V Acqua # Andes # Embossed Tip # España # Hand Tipped Maremma # Velluto Pelle #	W Alaska # Amazon # Antique # Derby Forte # Lucente Sabrina # Nbrtrp approved for inset back.	X Ducale * # Ducale Velour #	Y Cervo * # Copenhagen # Distressed # Gemma * Lucca * Marissa # Portofino Riva # Saddle Torello * #
---------------------------------	---	--	---	--

Check with your KnollTextiles or Spinneybeck Representative for changes or additions.

Marc Krusin

Guest Seating Collection

Side Chair with Arms

Designer(s):
Marc Krusin, 2011

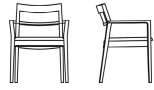

description	seat h	arm h	w	d	h	textile fabric yds.	required leather sq. ft.	weight	finish
MK01AU Krusin arm chair, uphol. inset back	18 1/2"	24 1/2"	23 1/2"	21 3/4"	30 1/2"	1.3	14.5	14 lbs.	ash or oak finish
	18 1/2"	24 1/2"	23 1/2"	21 3/4"	30 1/2"	1.3	14.5	14 lbs.	beech finish
	18 1/2"	24 1/2"	23 1/2"	21 3/4"	30 1/2"	1.3	14.5	14 lbs.	walnut finish
MK01R Seat basket replacement for side chair						0.8	14.5		
MK01RCN Woven rush seat basket replacement for side chair									light kraft

Order Code

Example: **MK01A-BE-S-K1207/17-K1207/4**

MK01A	Krusin arm chair
BE	Ebonized
S	Split upholstery option
K1207/17	seat: Knoll Felt, Pewter
K1207/4	back: Knoll Felt, Green

Oak:
Ebonized Oak (suffix OE)
Fumed Oak (suffix OF)
Grey Oak, White Ceruse (suffix OGW)
Grey Oak, Black Ceruse (suffix OGB)
Natural Oak (suffix ON)

Walnut:
American Walnut (suffix AW)

Optional Woven Seat:
An optional woven paper rush seat is available at an upcharge, from grade A pricing, of \$295 for side chairs and \$331 for lounge chairs. Place suffix CN between parent pattern number and wood finish suffix.

Example:MK01A-CN-BE

Split upholstery option:
The seat and back of the Krusin Side Chair can be specified in split upholstery. Indicate S before selected seat upholstery, followed by selected back upholstery. The price equals the price of the higher upholstery grade.

COM split fabric requirements:
Back upholstery: 0.5 yards
Seat upholstery: 0.8 yards

COL split leather requirements:
Back upholstery: 6 square feet
Seat upholstery: 14.5 square feet

Upholstery/COM information:
List prices shown include fabric or leather upholstery. Contact your Knoll representative for colors. Only approved KnollTextiles and Spinneybeck leathers may be ordered.

Customer's Own Material is available pending approval. For approval requirements, processing instructions and ordering information please see page 18.

KnollStudio natural wood finishes:
The Krusin Collection of guest seating features a low sheen, Greenguard approved, urethane finish. This finish, available on Ash, Oak, and Walnut delivers the tactility of natural wood while providing a durable matte finish.

Ash and Oak feature a unique staining process that replicate traditional cereused finishes.

KnollStudio Beech wood finishes:
KnollStudio Beech finishes complement a large variety of KnollStudio veneer and Knoll Office veneer finishes. To select correct complementary finish, please refer to KnollStudio Wood Finish Matrix on page 25. If no complementary finish is available, please refer to custom finish policy below.

Custom finishes:
Complementary finishes to any KnollStudio or Knoll Office wood finish are available at no upcharge. To complement non-Knoll wood veneer or lumber finishes, a one-time, non-negotiable net upcharge of \$662 applies. Re-orders are at no upcharge. Please contact your KnollStudio representative, dealer or Customer Service associate for complete custom finish information and Order Code. Minimum order quantity for any custom finish order: 4 chairs.

Certified Wood:
Chairs manufactured using FSC certified hardwoods are available through Custom Product Development. Extended leadtime and upcharge apply.

Maintenance:
See pages 28-29

Note:
The Krusin Collection chairs are Greenguard certified in all wood finishes.

Cal 133 Fire Code:
The Krusin Side Chairs comply with the California Technical Bulletin 133 standard if upholstered in Cal 133 approved upholstery. Specify suffix -C at end of pattern number and suffix -133 at end of textile selection. Upcharge applies, see page 18.

Construction

Frame:
Select American and European hard wood frames. Dowel and mortise and tenon construction, steam bent top rail. A bent laminate upholstered inset back is available. The back of inset features horizontal grain direction.

Upholstered Seat:
High density, polyurethane foam used in all upholstered areas. Elastic seat belt suspension.

Woven Rush Seats:
A woven natural paper rush seat is available on side and lounge chairs. Not available on chairs with inset back upholstery. Paper rush is a natural, uncoated material.

KnollStudio will not warrant soiled or stained woven seats. A one year warranty will cover woven seats for manufacturer's defects.

Seat basket replacements:
Upholstered and woven seats sit on chair frame. Screws lock basket in place for easy installation or removal.

Finish:
Beech, Catalyzed lacquer protective coating. Hand applied final wax coating. Ash, Oak, and Walnut, urethane protective coating. Hand applied final wax coating.

Glides:
Chairs feature nylon glides.

pattern no.	grades A	COM B	C	D	E	F	G	H	I	COL U	V	W	X	Y
MK01AU-(A101, O_)	\$1,778.	\$1,796.	\$1,816.	\$1,838.	\$1,854.	\$1,866.	\$1,888.	\$1,927.	\$1,956.	\$2,175.	\$2,230.	\$2,377.	\$2,406.	\$2,441.
MK01AU-()	1,502.	1,518.	1,539.	1,560.	1,577.	1,588.	1,609.	1,650.	1,679.	1,897.	1,953.	2,099.	2,129.	2,164.
MK01AU-(AW)	2,116.	2,133.	2,154.	2,175.	2,191.	2,204.	2,224.	2,265.	2,293.	2,511.	2,568.	2,714.	2,744.	2,779.
MK01R	343.	361.	381.	402.	418.	431.	451.	492.	521.	727.	782.	929.	958.	994.
MK01RCN	443.	0.	0.	0.	0.	0.	0.	0.	0.	0.	0.	0.	0.	0.

Approved KnollTextiles Grades/Fabrics

A Alignment # Beacon Bocce # Cat's Cradle # Chance Common Ground # Commuter Cloth # Crossroad Delite Dristi Foil Rap Heavy Metal Hourglass Mariner Monarch Overture Prep # Presto # Soliloquy Sonnet Trophy # Uni-Form	B continued Ferry Forza Gala II Grande Grandview Hollbrook Journey Keaton Knoll Felt Knoll Hopsack Little Devil Ludlow Melody Mini Stitch # Paradigm Petat Pusher Prairie Prim # Radiance Ransom Roam Rush Hour Spark # Spree # Summit Sutton Synth Tabloid Tinge Utmost Venue # Versa # Vinyl Westwood Wide Angle # Zipline #	C Atlas Axiom Baxter Cairo Charm Circa Classic Boucle Dahlia CR * Decade Durand Earthwork # Echo Empire Stripe Emmesh # Entourage # Essence Fable CR * Fibra Greenwich Hudson Hula Hoop Kaleidoscope CR Kaya CR Kora CR Lagos Legend CR Lore CR Magnolia Metro Milestone Moto CR Noble Palisade Panache CR Pullman Quark Roundtrip # Sahara Sequin CR	C continued Sinclair Smart Spectator # Spot On Star Struck Stepping Stones Swing Tight Rope Tilden * Tower Grid Treble CR Wit Zari CR Zen Wave	D Compass CR Coterie Eclat Weave Hologram In The Loop Island Kabuki Masquerade Menagerie Origins Woodland Zoom	E Aegean Cleo Highland Ikat Stripe Juno Katazome Kimono	
E continued Mamba Marquee Midpoint Sherman Shima Tryst Vatera Whip	F Atelier Biscayne Calais Cotton Velvet Cornaro Glider Icon Intrigue In Stitches Liberty Mod Plaid Rivington Soon Topography Totem Tweed Frieze	G continued Modern Tweed Serendipity Spencer Straie Stripe Ultrasuede Utrillo	H Arno Bavaria Catwalk Constance Firefly Magritte Stretch Appeal	I Aswan Byron Cato Cummings Diamond Days Dynamic Ita Jaipur Knoll Velvet Limani Mepal North Island Olema Piper Rutledge Sandis Tudor Vermeer Zimba	U Vicenza # Volo # V Acqua # Andes # Embossed Tip # España # Hand Tipped Maremma # Velluto Pelle # W Alaska # Amazon # Antique # Derby Forte # Lucente Sabrina # Not approved for inset back.	X Ducale * # Ducale Velour # Y Cervo * # Copenhagen # Distressed # Gemma * Lucca * Marissa # Portofino Riva # Saddle Torello * #

Spinneybeck Leather

Check with your KnollTextiles or Spinneybeck Representative for changes or additions.

Marc Krusin

Guest Seating Collection

Armless Side Chair

Designer(s):
Marc Krusin, 2011



description	seat h	w	d	h	textile fabric yds.	required leather sq. ft.	weight	finish
MK01C Krusin armless chair 	18 1/2"	20 1/4"	21 3/4"	30 1/2"	0.8	14.5	12 lbs.	ash or oak finish
	18 1/2"	20 1/4"	21 3/4"	30 1/2"	0.8	14.5	12 lbs.	beech finish
	18 1/2"	20 1/4"	21 3/4"	30 1/2"	0.8	14.5	12 lbs.	walnut finish
MK01R Seat basket replacement for side chair					0.8	14.5		
MK01RCN Woven rush seat basket replacement for side chair								light kraft

Order Code

<i>Example:</i>	MK01A-BE-K1207/17
MK01A	Krusin arm chair
BE	Ebonized
K1207/17	Knoll Felt, Pewter

Specify:

1. Pattern number
2. Woven rush seat, optional
3. Finish selection
4. Textile selection

Ordering Information:

Ash:
White Ash (suffix A101)

Beech frame stains:
Beech (suffix B311)
Bronzed Cherry (suffix B312A)
Burnt Walnut (suffix B313)
Deep Red Mahogany (suffix B328)
Ebonized (suffix BE)
Light Cherry (suffix B315)
Light Walnut (suffix B411)
Medium Cherry (suffix B319)
Medium Red Mahogany (suffix BR)
Medium Walnut (suffix B323)
Natural Beech (suffix BN)
Warm Brown Walnut (J)

Oak:
Ebonized Oak (suffix OE)
Fumed Oak (suffix OF)
Grey Oak, White Ceruse (suffix OGW)
Grey Oak, Black Ceruse (suffix OGB)
Natural Oak (suffix ON)

Walnut:
American Walnut (suffix AW)

Optional Woven Seat:
An optional woven paper rush seat is available at an upcharge, from grade A pricing, of \$295 for side chairs and \$331 for lounge chairs. Place suffix CN between parent pattern number and wood finish suffix.

Example:MK01A-CN-BE

Upholstery/COM information:
List prices shown include fabric or leather upholstery. Contact your Knoll representative for colors. Only approved KnollTextiles and Spinneybeck leathers may be ordered.

Customer's Own Material is available pending approval. For approval requirements, processing instructions and ordering information please see page 18.

KnollStudio natural wood finishes:
The Krusin Collection of guest seating features a low sheen, Greenguard approved, urethane finish. This finish, available on Ash, Oak, and Walnut delivers the tactility of natural wood while providing a durable matte finish.

Ash and Oak feature a unique staining process that replicate traditional cereused finishes.

KnollStudio Beech wood finishes:
KnollStudio Beech finishes complement a large variety of KnollStudio veneer and Knoll Office veneer finishes. To select correct complementary finish, please refer to KnollStudio Wood Finish Matrix on page 25. If no complementary finish is available, please refer to custom finish policy below.

Custom finishes:
Complementary finishes to any KnollStudio or Knoll Office wood finish are available at no upcharge. To complement non-Knoll wood veneer or lumber finishes, a one-time, non-negotiable net upcharge of \$662 applies. Re-orders are at no upcharge. Please contact your KnollStudio representative, dealer or Customer Service associate for complete custom finish information and Order Code. Minimum order quantity for any custom finish order: 4 chairs.

Certified Wood:
Chairs manufactured using FSC certified hardwoods are available through Custom Product Development. Extended leadtime and upcharge apply.

Maintenance:
See pages 28-29

Cal 133 Fire Code #:
The Krusin Side Chairs comply with the California Technical Bulletin 133 standard if upholstered in Cal 133 approved upholstery. Specify suffix -C at end of pattern number and suffix -133 at end of textile selection. Upcharge applies, see page 18.

Construction

Frame:
Select American and European hard wood frames. Dowel and mortise and tenon construction, steam bent top rail. A bent laminate upholstered inset back is available. The back of inset features horizontal grain direction.

Upholstered Seat:
High density, polyurethane foam used in all upholstered areas. Elastic seat belt suspension.

Woven Rush Seats:
A woven natural paper rush seat is available on side and lounge chairs. Not available on chairs with inset back upholstery. Paper rush is a natural, uncoated material.

KnollStudio will not warrant soiled or stained woven seats. A one year warranty will cover woven seats for manufacturer's defects.

Seat basket replacements:
Upholstered and woven seats sit on chair frame. Screws lock basket in place for easy installation or removal.

Finish:
Beech, Catalyzed lacquer protective coating. Hand applied final wax coating. Ash, Oak, and Walnut, urethane protective coating. Hand applied final wax coating.

Glides:
Chairs feature nylon glides.

Note:
The Krusin Collection chairs are Greenguard certified in all wood finishes.

pattern no.	grades A	COM B	C	D	E	F	G	H	I	COL U	V	W	X	Y
MK01C-(A101, O_)	\$1,354.	\$1,370.	\$1,392.	\$1,412.	\$1,429.	\$1,440.	\$1,462.	\$1,503.	\$1,531.	\$1,749.	\$1,805.	\$1,952.	\$1,980.	\$2,016.
MK01C-(-)	1,074.	1,094.	1,113.	1,135.	1,150.	1,164.	1,184.	1,223.	1,252.	1,454.	1,509.	1,656.	1,685.	1,720.
MK01C-(AW)	1,690.	1,708.	1,727.	1,749.	1,766.	1,777.	1,798.	1,840.	1,867.	2,086.	2,141.	2,287.	2,317.	2,354.
MK01R	343.	361.	381.	402.	418.	431.	451.	492.	521.	727.	782.	929.	958.	994.
MK01RCN	443.	0.	0.	0.	0.	0.	0.	0.	0.	0.	0.	0.	0.	0.

Approved KnollTextiles Grades/Fabrics

A Alignment # Beacon Bocce # Cat's Cradle # Chance Common Ground # Commuter Cloth # Crossroad Delite Dristi Foil Rap Heavy Metal Hourglass Mariner Monarch Overture Prep # Presto # Soliloquy Sonnet Trophy # Uni-Form	B continued Ferry Forza Gala II Grande Grandview Hollbrook Journey Keaton Knoll Felt Knoll Hopsack Little Devil Ludlow Melody Mini Stitch # Paradigm Petal Pusher Prairie Prim # Radiance Ransom Roam Rush Hour Spark # Spree # Summit Sutton Synth Tabloid Tinge Utmost Venue # Versa # Vinyl Westwood Wide Angle # Zipline #	C Atlas Axiom Baxter Cairo Charm Circa Classic Boucle Dahlia CR * Decade Durand Earthwork # Echo Empire Stripe Enmesh # Entourage # Essence Fable CR * Fibra Greenwich Hudson Hula Hoop Kaleidoscope CR Kora CR Lagos Legend CR Lore CR Magnolia Metro Milestone Moto CR Noble Palisade Panache CR Quark Roundtrip # Sahara Sequin CR Sinclair Smart	C continued Pullman Spectator # Spot On Star Struck Stepping Stones Swing Tight Rope Tilden * Tower Grid Trebble CR Wit Zari CR	D Compass CR Coterie Eclat Weave Hologram In The Loop Island Masquerade Menagerie Origins Woodland Zoom	E Aegean Cleo Highland Ikati Stripe Juno Katazome Kimono Mamba Marquee Midpoint Sherman	E continued Shima Tryst Vatera Whip	F Atelier Biscayne Calais Cotton Velvet Cornaro Glider Icon Intrigue In Stitches Liberty Mod Plaid Rivington Soon Topography Totem Tweed Frieze	G continued Straie Stripe Ultrasuede Utrillo	H Arno Bavaria Catwalk Constance Firefly Magritte Stretch Appeal	I Aswan Byron Cato Cummings Diamond Days Dynamic Ita Jaipur Knoll Velvet Limani Mepal North Island Olema Piper Rutledge Sandis Tudor Vermeer Zimba	U Vicenza # Volo #	V Acqua # Andes # Bavaria Catwalk Espana # Hand Tipped Maremma # Velluto Pelle #	W Alaska # Amazon # Antique # Derby Forte # Lucente Sabrina # Saddle Torello * #	X Ducale * # Ducale Velour #	Y Cervo * # Copenhagen # Distressed # Gemma * Lucca * Marissa # Portofino Riva # Saddle Torello * #
---	---	--	--	---	---	--	--	--	--	--	---------------------------------	---	--	---	--

Spinneybeck Leather

indicates approved for inset back.

Check with your KnollTextiles or Spinneybeck Representative for changes or additions.

Marc Krusin

Guest Seating Collection

Armless Side Chair

Designer(s):
Marc Krusin, 2011

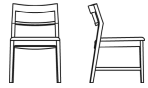

description	seat h	w	d	h	textile fabric yds.	required leather sq. ft.	weight	finish
MK01CU Krusin armless chair, uphol. inset back	18½"	20¼"	21¾"	30½"	1.3	14.5	12 lbs.	ash or oak finish
	18½"	20¼"	21¾"	30½"	1.3	14.5	12 lbs.	beech finish
	18½"	20¼"	21¾"	30½"	1.3	14.5	12 lbs.	walnut finish
MK01R Seat basket replacement for side chair					0.8	14.5		
MK01RCN Woven rush seat basket replacement for side chair								light kraft

Order Code

Example: **MK01A-BE-S-K1207/17-K1207/4**

MK01A	Krusin arm chair
BE	Ebonized
S	Split upholstery option
K1207/17	seat: Knoll Felt, Pewter
K1207/4	back: Knoll Felt, Green

Oak:
Ebonized Oak (suffix OE)
Fumed Oak (suffix OF)
Grey Oak, White Ceruse (suffix OGW)
Grey Oak, Black Ceruse (suffix OGB)
Natural Oak (suffix ON)

Walnut:
American Walnut (suffix AW)

Optional Woven Seat:
An optional woven paper rush seat is available at an upcharge, from grade A pricing, of \$295 for side chairs and \$331 for lounge chairs. Place suffix CN between parent pattern number and wood finish suffix.

Example:MK01A-CN-BE

Split upholstery option:
The seat and back of the Krusin Side Chair can be specified in split upholstery. Indicate S before selected seat upholstery, followed by selected back upholstery. The price equals the price of the higher upholstery grade.

COM split fabric requirements:
Back upholstery: 0.5 yards
Seat upholstery: 0.8 yards

COL split leather requirements:
Back upholstery: 6 square feet
Seat upholstery: 14.5 square feet

Upholstery/COM information:
List prices shown include fabric or leather upholstery. Contact your Knoll representative for colors. Only approved KnollTextiles and Spinneybeck leathers may be ordered.

Customer's Own Material is available pending approval. For approval requirements, processing instructions and ordering information please see page 18.

KnollStudio natural wood finishes:
The Krusin Collection of guest seating features a low sheen, Greenguard approved, urethane finish. This finish, available on Ash, Oak, and Walnut delivers the tactility of natural wood while providing a durable matte finish.

Ash and Oak feature a unique staining process that replicate traditional cereused finishes.

Construction

Frame:
Select American and European hard wood frames. Dowel and mortise and tenon construction, steam bent top rail. A bent laminate upholstered inset back is available. The back of inset features horizontal grain direction.

Upholstered Seat:
High density, polyurethane foam used in all upholstered areas. Elastic seat belt suspension.

Woven Rush Seats:
A woven natural paper rush seat is available on side and lounge chairs. Not available on chairs with inset back upholstery. Paper rush is a natural, uncoated material.

KnollStudio will not warrant soiled or stained woven seats. A one year warranty will cover woven seats for manufacturer's defects.

Seat basket replacements:
Upholstered and woven seats sit on chair frame. Screws lock basket in place for easy installation or removal.

Finish:
Beech, Catalyzed lacquer protective coating. Hand applied final wax coating. Ash, Oak, and Walnut, urethane protective coating. Hand applied final wax coating.

Glides:
Chairs feature nylon glides.

Note:
The Krusin Collection chairs are Greenguard certified in all wood finishes.

pattern no.	grades A	COM B	C	D	E	F	G	H	I	COL U	V	W	X	Y
MK01CU-(A101, O_)	\$1,679.	\$1,695.	\$1,716.	\$1,738.	\$1,753.	\$1,766.	\$1,787.	\$1,827.	\$1,855.	\$2,074.	\$2,130.	\$2,277.	\$2,307.	\$2,342.
MK01CU-()	1,400.	1,419.	1,438.	1,460.	1,476.	1,487.	1,509.	1,549.	1,578.	1,778.	1,834.	1,980.	2,010.	2,046.
MK01CU-(AW)	2,014.	2,033.	2,052.	2,074.	2,091.	2,103.	2,124.	2,164.	2,192.	2,413.	2,466.	2,612.	2,643.	2,679.
MK01R	343.	361.	381.	402.	418.	431.	451.	492.	521.	727.	782.	929.	958.	994.
MK01RCN	443.	0.	0.	0.	0.	0.	0.	0.	0.	0.	0.	0.	0.	0.

Approved KnollTextiles Grades/Fabrics

A Alignment † Beacon Bocce † Cat's Cradle † Chance Common Ground † Commuter Cloth † Delite Dristi Foil Rap Heavy Metal Hourglass Mariner Monarch Overture Prep † Presto † Soliloquy Sonnet Trophy † Uni-Form	B continued Ferry Forza Gala II Grande Grandview Hollbrook Journey Keaton Knoll Felt Knoll Hopsack Little Devil Ludlow Melody Mini Stitch † Paradigm Petat Pusher Prairie Prim † Radiance Ransom Roam Rush Hour Spark † Spree † Summit Sutton Synth Tabloid Tinge Utmost Venue † Versa † Vinyl Westwood Wide Angle † Zipline †	C Atlas Axiom Baxter Cairo Charm Circa Classic Boucle Dahlia CR * Decade Durand Earthwork † Echo Empire Stripe Enmesh † Entourage † Essence Fable CR * Fibra Greenwich Hudson Hula Hoop Kaleidoscope CR Kora CR Lagos Legend CR Lore CR Magnolia Metro Milestone Moto CR Noble Palisade Panache CR Quark Roundtrip † Sahara Sequin CR Sinclair Smart	C continued Pullman Spectator † Spot On Star Struck Stepping Stones Swing Tight Rope Tilden * Tower Grid Treble CR Wit Zari CR	D Compass CR Coterie Eclat Weave Hologram In The Loop Island Masquerade Menagerie Origins Woodland Zoom	E Aegean Cleo Highland Ikat Stripe Juno Katazome Kimono Mamba Marquee Midpoint Sherman	E continued Shima Tryst Vatera Whip	F Atelier Biscayne Calais Cotton Velvet Cornaro Glider Icon Intrigue In Stitches Liberty Mod Plaid Rivington Soon Topography Totem Tweed Frieze	G continued Straie Stripe Ultrasuede Utrillo	H Arno Bavaria Catwalk Constance Firefly Magritte Stretch Appeal	I Aswan Byron Cato Cummings Diamond Days Dynamic Ita Jaipur Knoll Velvet Limani Mepal North Island Olema Piper Rutledge Sandis Tudor Vermeer Zimba	U Vicenza † Volo †	V Acqua † Andes † Embossed Tip † España † Hand Tipped Maremma † Velluto Pelle †	W Alaska † Amazon † Antique † Derby Forte † Lucente Sabrina † Unapproved for inset back.	X Ducale * † Ducale Velour †	Y Cervo * † Copenhagen † Distressed † Gemma * Lucca * Marissa † Portofino Riva † Saddle Torello * †
--	---	--	---	---	--	--	--	--	--	--	---------------------------------	---	---	---	--

Spinneybeck Leather

Check with your KnollTextiles or Spinneybeck Representative for changes or additions.

Marc Krusin

Guest Seating Collection

Lounge Seating

Designer(s):
Marc Krusin, 2011

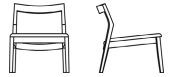
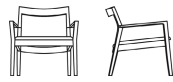

description	seat h	arm h	w	d	h	textile fabric yds.	required leather sq. ft.	weight	finish
MK02A Krusin Lounge arm chair	16"	21 1/2"	27"	25 3/4"	26"	0.9	16.5	14 lbs.	beech finish
	16"	21 1/2"	27"	25 3/4"	26"	0.9	16.5	14 lbs.	ash or oak finish
	16"	21 1/2"	27"	25 3/4"	26"	0.9	16.5	14 lbs.	walnut finish
MK02C Krusin Lounge armless chair	16"		23 1/2"	25 3/4"	26"	0.9	16.5	12 lbs.	beech finish
	16"		23 1/2"	25 3/4"	26"	0.9	16.5	12 lbs.	ash or oak finish
	16"		23 1/2"	25 3/4"	26"	0.9	16.5	12 lbs.	walnut finish
MK02R Seat basket replacement for lounge chair						0.9	16.5		
MK02RCN Woven rush seat basket replacement for lounge chair									light kraft

Order Code

<i>Example:</i>	MK02A-CN-A101
MK02A	Krusin lounge arm chair
CN	Woven rush seat
A101	White Ash

Specify:

1. Pattern number
2. Woven rush seat, optional
3. Finish selection
4. Textile selection

Ordering Information:

Ash:
White Ash (suffix A101)

Beech frame stains:
Beech (suffix B311)
Bronzed Cherry (suffix B312A)
Burnt Walnut (suffix B313)
Deep Red Mahogany (suffix B328)
Ebonized (suffix BE)
Light Cherry (suffix B315)
Light Walnut (suffix B411)
Medium Cherry (suffix B319)
Medium Red Mahogany (suffix BR)
Medium Walnut (suffix B323)
Natural Beech (suffix BN)
Warm Brown Walnut (J)

Oak:
Ebonized Oak (suffix OE)
Fumed Oak (suffix OF)
Grey Oak, White Ceruse (suffix OGW)
Grey Oak, Black Ceruse (suffix OGB)
Natural Oak (suffix ON)

Walnut:
American Walnut (suffix AW)

Optional Woven Seat:

An optional woven paper rush seat is available at an upcharge, from grade A pricing, of \$295 for side chairs and \$331 for lounge chairs. Place suffix CN between parent pattern number and wood finish suffix.

*Example:***MK02A-CN-A101**

Upholstery/COM information:

List prices shown include fabric or leather upholstery. Contact your Knoll representative for colors. Only approved KnollTextiles and Spinneybeck leathers may be ordered.

Customer's Own Material is available pending approval. For approval requirements, processing instructions and ordering information please see page 18.

KnollStudio natural wood finishes:

The Krusin Collection of guest seating features a low sheen, Greenguard approved, urethane finish. This finish, available on Ash, Oak, and Walnut delivers the tactility of natural wood while providing a durable matte finish.

Ash and Oak feature a unique staining process that replicate traditional cereused finishes.

KnollStudio Beech wood finishes:

KnollStudio Beech finishes complement a large variety of KnollStudio veneer and Knoll Office veneer finishes. To select correct complementary finish, please refer to KnollStudio Wood Finish Matrix on page 25. If no complementary finish is available, please refer to custom finish policy below.

Custom finishes:

Complementary finishes to any KnollStudio or Knoll Office wood finish are available at no upcharge. To complement non-Knoll wood veneer or lumber finishes, a one-time, non-negotiable net upcharge of \$662 applies. Re-orders are at no upcharge. Please contact your KnollStudio representative, dealer or Customer Service associate for complete custom finish information and Order Code. Minimum order quantity for any custom finish order: 4 chairs.

Certified Wood:

Chairs manufactured using FSC certified hardwoods are available through Custom Product Development. Extended leadtime and upcharge apply.

Maintenance:

See pages 28-29

Note:

The Krusin Collection chairs are Greenguard certified in all wood finishes.

Cal 133 Fire Code #:

The Krusin Lounge Chairs comply with the California Technical Bulletin 133 standard if upholstered in Cal 133 approved upholstery. Specify suffix -C at end of pattern number and suffix -133 at end of textile selection. Upcharge applies, see page 18.

Construction

Frame:

Select American and European hard wood frames. Dowel and mortise and tenon construction, steam bent top rail.

Upholstered Seat:

High density, polyurethane foam used in all upholstered areas. Elastic seat belt suspension.

Woven Rush Seats:

A woven natural paper rush seat is available on side and lounge chairs. Not available on chairs with inset back upholstery. Paper rush is a natural, uncoated material.

KnollStudio will not warrant soiled or stained woven seats. A one year warranty will cover woven seats for manufacturer's defects.

Seat basket replacements:

Upholstered and woven seats sit on chair frame. Screws lock basket in place for easy installation or removal.

Finish:

Beech, Catalyzed lacquer protective coating. Hand applied final wax coating. Ash, Oak, and Walnut, urethane protective coating. Hand applied final wax coating.

Glides:

Chairs feature nylon glides.

pattern no.	grades	COM	C	D	E	F	G	H	I	COL	V	W	X	Y
MK02A-()	\$1,725.	\$1,743.	\$1,766.	\$1,787.	\$1,806.	\$1,821.	\$1,844.	\$1,888.	\$1,921.	\$2,138.	\$2,204.	\$2,368.	\$2,402.	\$2,444.
MK02A-(A101, O_)	1,796.	1,814.	1,836.	1,858.	1,878.	1,891.	1,916.	1,958.	1,992.	2,228.	2,292.	2,458.	2,493.	2,533.
MK02A-(AW)	2,098.	2,116.	2,137.	2,159.	2,179.	2,192.	2,216.	2,259.	2,293.	2,530.	2,594.	2,758.	2,794.	2,834.
MK02C-()	1,602.	1,619.	1,642.	1,663.	1,682.	1,695.	1,719.	1,764.	1,796.	2,014.	2,079.	2,244.	2,280.	2,320.
MK02C-(A101, O_)	1,672.	1,690.	1,713.	1,735.	1,752.	1,768.	1,791.	1,834.	1,867.	2,104.	2,167.	2,333.	2,368.	2,411.
MK02C-(AW)	1,974.	1,992.	2,013.	2,035.	2,055.	2,069.	2,092.	2,135.	2,168.	2,403.	2,469.	2,635.	2,670.	2,711.
MK02R	425.	443.	464.	485.	501.	513.	535.	574.	602.	862.	918.	1,065.	1,095.	1,130.
MK02RCN	478.	0.	0.	0.	0.	0.	0.	0.	0.	0.	0.	0.	0.	0.

Approved KnollTextiles Grades/Fabrics



A Alignment # Beacon Bocce # Cat's Cradle # Chance Common Ground # Commuter Cloth # Crossroad Delite Dristi Foil Rap Heavy Metal Hourglass Mariner Monarch Overture Prep # Presto # Soliloquy Sonnet Trophy # Uni-Form	B continued Ferry Forza Gala II Grande Grandview Hollbrook Journey Keaton Knoll Hopsack Knoll Felt Little Devil Ludlow Melody Mini Stitch # Paradigm Petal Pusher Prairie Prim # Radiance Ransom Roam Rush Hour Spark # Spree # Summit Sutton Synth Tabloid Tinge Utmost Venue # Versa # Vinyl Westwood Wide Angle # Zipline #	C Atlas Axiom Baxter Cairo Charm Circa Classic Boucle Dahlia CR * Decade Durand Earthwork # Echo Empire Stripe Enmesh # Entourage # Essence Fibra CR * Fibra Greenwich Hudson Hula Hoop Kaleidoscope CR Kora CR Lagos Legend CR Lore CR Magnolia Metro Milestone Moto CR Noble Palisade Panache CR Pullman Quark Roundtrip # Sahara Sequin CR Sinclair Smart	C continued Spectator # Spot On Star Struck Stepping Stones Swing Tight Rope Tilden * Tower Grid Treble CR Wit Zari CR	D Compass CR Coterie Eclat Weave Hologram In The Loop Island Masquerade Menagerie Origins Woodland Zoom	E Aegean Cleo Highland Ikata Stripe Juno Katazome Kimono Mamba Marquee Midpoint Sherman Shima Tryst Vatera Whip	F Atelier Biscayne Calais Cotton Velvet Cornaro Glider Icon Intrigue In Stitches Liberty Mod Plaid Rivington Soon Topography Totem Tweed Frieze	G Alter Ego Gibson Haze Kamani Melange Modern Tweed Serendipity Spencer Straie Stripe Ultrasuede Utrillo	H Arno Bavaria Catwalk Constance Firefly Magritte Stretch Appeal Aswan Byron Cato Cummings Diamond Days Dynamic Ita Jaipur Knoll Velvet Limani Mepal North Island Olema Piper Rutledge Sandis Tudor Vermeer Zimba	I Vicenza # Volò # Acqua # Andes # Embossed Tip # Hand Tipped España # Maremma # Velluto Pelle # Alaska # Amazon # Antique # Derby Forte # Lucente Sabrina # Umbria Check with your KnollTextiles or Spinneybeck Representative for changes or additions.	V Cervo # Copenhagen # Distressed # Gemma Lucca Marissa # Portofino Riva # Saddle Torello #	W Alaska # Amazon # Antique # Derby Forte # Lucente Sabrina # Umbria Check with your KnollTextiles or Spinneybeck Representative for changes or additions.	X Ducale # Ducale Velour #	Y Cervo # Copenhagen # Distressed # Gemma Lucca Marissa # Portofino Riva # Saddle Torello #
---	---	---	--	---	---	--	--	--	--	--	--	---	--

Spinneybeck Leather

Maya Lin

Stones

Seats and Coffee Table

	description	w	d	h	material	textile fabric yds.	req. leather sq. ft.	weight
<i>Designer(s):</i> Maya Lin, 1998	83Y Stones adult seat 	27"	19"	15"	molded polyethylene no weight			13 lbs.
		27"	19"	15"	molded polyethylene with weight			22 lbs.
<i>Award(s):</i> Best of Neocon Silver Award, 1998; Good Design Award, Chicago Athenaeum, 1998; Good Design Award, 2006		83Y-K Seat cushion for adult seat				1.3	30	
		84Y Stones child seat 	16"	12"	10"	molded polyethylene no weight		
	16"		12"	10"	molded polyethylene with weight			17 lbs.
	84Y-K Seat cushion for child seat				1.0	25		

pattern no.	unuphol.	grades A	COM B	C	D	E	F	G	H	I	COL U	V	W	X	Y
83YM-()	\$650.														
83YMW-()	769.														
83Y-K-()		675.	709.	745.	781.	813.	835.	874.	944.	996.	1,384.	1,560.	1,924.	1,999.	2,089.
84YM-()	447.														
84YMW-()	516.														
84Y-K-()		493.	529.	561.	595.	622.	641.	675.	745.	792.	1,224.	1,390.	1,722.	1,795.	1,873.

Order Code

<i>Example:</i>	84YM-W-KHRC-K642/5
84YM	Stones child seat
W	With weight
KHRC	Khaki
K642/5	Mariner, Steel

Specify:

1. Pattern number
2. Weight option
3. Finish option
4. Textile selection

Ordering Information:

Molded Polyethylene finish: White (suffix WV)

Molded Polyethylene finishes with 100% recycled content:

- Blue (suffix BLRC)
- Chartreuse (CHRC)
- Khaki (suffix KHRC)
- Silver (suffix SPRC)
- Tarmac (suffix TARC)
- Warm Red (suffix WRRC)

Upholstery/COM information: Prices shown include fabric or leather upholstery. Contact your Knoll representative for colors. Only approved KnollTextiles and Spinneybeck leathers may be ordered.

Customer's Own Material is available pending approval. For approval requirements, processing instructions and ordering information please see page 18.

Seats and Table:

Stones are available in molded polyethylene in virgin or recycled material. Both versions are fully finished and are enclosed on top, bottom and sides. Seat tops are slightly concave and table top is slightly convex.

Note:

The original Maya Lin Coffee Table (85T42) is no longer available and has been replaced by a modified version (85T32). Please note the new dimensions and weight.

Outdoor application note:

With proper care and limited exposure to the elements, Stones tables and seats without seat pads are suitable for outdoor use. Polyethylene stones in all colors can be used outdoors. Remove water in the concave seats to avoid permanent stains. White patina may appear on surface. During cool or inclement weather, it is recommended to bring Stones inside.

Child seat application note:

Child seat is for child use only and not sized to be used by adults. Do not use as stepping stool.

Security Kit: Security kit hooks onto latch on underside of polyethylene Stone directly into the ground for permanent applications. Due to variations in flooring, kit does not include hardware.

UV Testing:

Maya Lin Stones in polyethylene in all colors have passed UV testing standards including 100 hours under intense UV radiation to test for colorfastness.

Cal 133:

For polyethylene Maya Lin Stones in a Cal 133 finish please request through CPD. Please note, specifying the Maya Lin Stone seat pad in a Cal 133 textile does not make the polyethylene Stone Cal 133 approved.

Maintenance:

See pages 28-29.

Note:

The Maya Lin Seat and Coffee Table are Greenguard approved.

The Child's Maya Lin Stone is compliant to the Consumer Product Safety Improvement Act of 2008 for Children's Products, 16 C.F.R. 1303, CPSIA Title 1 Section 101 for Total Lead in Substrates and Surface Coatings.

Construction

Molded Polyethylene Stones:

Polyethylene stones have integral color with a light texture and a low gloss finish, available in one color.

Recycled Molded Polyethylene Stones:

Recycled polyethylene stones are composed of 100% recycled polyethylene in six colors. Black specs will appear randomly on the surface of the stone. Color will vary slightly from stone to stone. Warranty claims for color variations will not be honored.

Weighted Polyethylene Stones:

Adult and child stones in molded polyethylene can be specified with or without weight. For stones with weight, sand is added at the factory. Weight can be adjusted in the field through access on underside of the stones. There is no option for a sand kit if the Stones are ordered without weight. The coffee table can only be specified without weight.

Seat cushions (seats only):

Seat cushions are 2 1/4" thick, solid foam piece with tapered edge and fabric or leather zip-lock cover. Seat cushions are fully upholstered on top and bottom. Seat cushions are not attached to Stone.

Approved KnollTextiles Grades/Fabrics

A	B	C	D	E	F	G
Alignment #	continued Ludlow	continued Empire Stripe	Compass CR			
Beacon	Mini Stitch	Emmesh #	Coterie			
Bocce	Melody	Entourage	Eclat Weave			
Cat's Cradle	Paradigm	Essence	Hologram			
Chance	Petal Pusher	Fable CR	Island			
Common Ground #	Pogo #	Fibra	Masquerade			
Commuter Cloth #	Prairie	Greenwich	Menagerie			
Crossroad	Prim	Hudson	Origins			
Delite	Radiance	Hula Hoop	Woodland			
Dristi	Ransom	Kaleidoscope CR	Zoom			
Hourglass	Roam	Kora CR				
Mariner #	Rush Hour	Lagos				
Monarch #	Spark #	Legend CR	E			
Overture	Spree	Lore CR	Aegean			
Prep #	Summit	Magnolia	Cleo			
Presto #	Sutton	Metro	Demure			
Soliloquy	Synth	Milestone	Highland			
Sonnet	Tabloid	Moto CR	Ikat Stripe			
Trophy	Tinge	Noble	Juno			
Uni-Form	Venue	Palisade	Katazome			
	Versa	Panache CR	Kimono			
	Vinyl	Pullman	Mamba			
	Westwood	Marquee	Meroe			
	Wide Angle #	Quark	Midpoint			
	Yeni	Roundtrip	Nature Walk			
	Zipline	Sahara	Sherman			
		Sequin CR	Shima			
		Sinclair	Tryst			
		Smart	Vatera			
		Spectator	Whip			
		Spot On				
		Star Struck				
		Stepping Stones				
		Swing	F			
		Tilden	Atelier			
		Tower Grid	Biscayne			
		Treble CR	Calais Cotton			
		Wit	Velvet			
		Zari CR	Cornaro			

Spinneybeck Leather

U	X
Vicenza	Ducale
Volo	Ducale Velour
V	Y
Acqua	Cervo
Andes	Copenhagen
Embossed Tipped	Dressed
España	Gemma
Hand Tipped	Lucca
Velluto Pelle	Marissa
	Portofino
	Riva
	Torello



Approved for Cal 133 upholstery.

Check with your KnollTextiles or Spinneybeck Representative for changes or additions.

Maya Lin

Stones

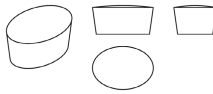
Seats and Coffee Table

	description	w	d	h	material	textile fabric yds.	req. leather sq. ft.	weight
<i>Designer(s):</i> Maya Lin, 1998	85T32M Stones coffee table 	32"	22 1/2"	15"	molded polyethylene	no weight		26.5 lbs.
<i>Award(s):</i> Best of Neocon Silver Award, 1998; Good Design Award, Chicago Athenaeum, 1998; Good Design Award, 2006								
	83ANCHOR Stone Security Kit							

Order Code

<i>Example:</i>	84YM-W-KHRC-K642/5
84YM	Stones child seat
W	With weight
KHRC	Khaki
K642/5	Mariner, Steel

Specify:

1. Pattern number
2. Weight option
3. Finish option
4. Textile selection

Ordering Information:

Molded Polyethylene finish:
White (suffix WV)

Molded Polyethylene finishes with 100% recycled content:

- Blue (suffix BLRC)
- Chartreuse (CHRC)
- Khaki (suffix KHRC)
- Silver (suffix SPRC)
- Tarmac (suffix TARC)
- Warm Red (suffix WRRC)

Upholstery/COM information:

Prices shown include fabric or leather upholstery. Contact your Knoll representative for colors. Only approved KnollTextiles and Spinneybeck leathers may be ordered.

Customer's Own Material is available pending approval. For approval requirements, processing instructions and ordering information please see page 18.

Seats and Table:

Stones are available in molded polyethylene in virgin or recycled material. Both versions are fully finished and are enclosed on top, bottom and sides. Seat tops are slightly concave and table top is slightly convex.

Note:

The original Maya Lin Coffee Table (85T42) is no longer available and has been replaced by a modified version (85T32). Please note the new dimensions and weight.

Outdoor application note:

With proper care and limited exposure to the elements, Stones tables and seats without seat pads are suitable for outdoor use. Polyethylene stones in all colors can be used outdoors. Remove water in the concave seats to avoid permanent stains. White patina may appear on surface. During cool or inclement weather, it is recommended to bring Stones inside.

Child seat application note:

Child seat is for child use only and not sized to be used by adults. Do not use as stepping stool.

Security Kit:

Security kit hooks onto latch on underside of polyethylene Stone directly into the ground for permanent applications. Due to variations in flooring, kit does not include hardware.

UV Testing:

Maya Lin Stones in polyethylene in all colors have passed UV testing standards including 100 hours under intense UV radiation to test for colorfastness.

Cal 133:

For polyethylene Maya Lin Stones in a Cal 133 finish please request through CPD. Please note, specifying the Maya Lin Stone seat pad in a Cal 133 textile does not make the polyethylene Stone Cal 133 approved.

Maintenance:

See pages 28-29.

Note:

The Maya Lin Seat and Coffee Table are Greenguard approved.

The Child's Maya Lin Stone is compliant to the Consumer Product Safety Improvement Act of 2008 for Children's Products, 16 C.F.R. 1303, CPSIA Title 1 Section 101 for Total Lead in Substrates and Surface Coatings.

Construction

Molded Polyethylene Stones:

Polyethylene stones have integral color with a light texture and a low gloss finish, available in one color.

Recycled Molded Polyethylene Stones:

Recycled polyethylene stones are composed of 100% recycled polyethylene in six colors. Black specs will appear randomly on the surface of the stone. Color will vary slightly from stone to stone. Warranty claims for color variations will not be honored.

Weighted Polyethylene Stones:

Adult and child stones in molded polyethylene can be specified with or without weight. For stones with weight, sand is added at the factory. Weight can be adjusted in the field through access on underside of the stones. There is no option for a sand kit if the Stones are ordered without weight. The coffee table can only be specified without weight.

Seat cushions (seats only):

Seat cushions are 2 1/4" thick, solid foam piece with tapered edge and fabric or leather zip-lock cover. Seat cushions are fully upholstered on top and bottom. Seat cushions are not attached to Stone.

pattern no.	unuphol.	grades	COM	C	D	E	F	G	H	I	COL	V	W	X	Y
85T32M-()	\$1,170.														
83ANCHOR	153.														

Approved KnollTextiles Grades/Fabrics

A Alignment # Beacon Bocce Cat's Cradle Chance Common Ground # Commuter Cloth # Crossroad Delite Dristi Hourglass Mariner # Monarch # Overture Prep # Presto # Soliloquy Sonnet Trophy Uni-Form	B Abacus # Argyle Backdrop Belize Bistro # Boundary # Calypso Cameo Chroma # Chronicle Close Knit # Diva Dovetail # Ferry Forza Gala II Grande Grandview Helios Holbrook Journey Keaton Knoll Felt Knoll Hopsack Little Devil	C continued Ludlow Mini Stitch Melody Paradigm Petal Pusher Pogo # Prairie Prim Radiance Ransom Roam Rush Hour Spark # Spree Summit Sutton Synth Tabloid Tinge Venue Versa Vinyl Westwood Wide Angle # Yeni Zipline	D continued Empire Stripe Enmesh # Entourage Essence Fable CR Fibra Greenwich Hudson Hula Hoop Kaleidoscope CR Kora CR Lagos Legend CR Lore CR Magnolia Metro Milestone Moto CR Noble Palisade Panache CR Pullman Quark Roundtrip Sahara Sequin CR Sinclair Smart Spectator Spot On Star Struck Stepping Stones Swing Tilden Tower Grid Treble CR Wit Zari CR	E Aegean Cleo Demure Highland Ikat Stripe Juno Katazome Kimono Mamba Marquee Pullman Quark Roundtrip Sahara Sequin CR Sinclair Smart Spectator Spot On Star Struck Stepping Stones Swing Tilden Tower Grid Treble CR Wit Zari CR	F continued Compass CR Coterie Eclat Weave Hologram Island Masquerade Menagerie Origins Woodland Zoom	G Alter Ego Arber Gibson Haze Kamani Melange Modern Tweed Petite Floral Serendipity Spencer Straie Stripe Ultrasuede # Utrillo	H Arno Bavaria Catwalk Constance Firefly Magritte Stretch Appeal	I Aswan Byron Cato Diamond Days Dynamic Ita Jaipur Knoll Velvet Limani North Island Olema Piper Rutledge Tudor Vermeer Zimba	U Vicenza Volo	V Acqua Andes España Hand Tipped Velluto Pelle	W Alaska Amazon Antique Derby Forte Lucente Sabrina Umbria # Approved for Cal 133 upholstery.	X Ducale Ducale Velour	Y Cervo Copenhagen Distressed Gemma Lucca Marissa Portofino Riva Torello
--	---	---	---	--	---	--	--	---	-----------------------------	--	---	-------------------------------------	--

Spinneybeck Leather

Check with your KnollTextiles or Spinneybeck Representative for changes or additions.

Piero Lissoni

Divina® Lounge Seating

Designer(s):
Piero Lissoni, 2001



description	seat h	arm h	w	d	h	foam type	textile	req.	weight
							fabric yds.	leather sq. ft.	
67S Petite lounge chair	16 1/4"	24 1/2"	30 1/2"	31 1/4"	32 1/2"	standard	4.5	72	42 lbs.
67 Standard lounge chair	16 1/4"	24 1/4"	37"	35 1/2"	31 1/4"	standard	7.5	108	59 lbs.
	16 1/4"	24 1/4"	37"	35 1/2"	31 1/4"	dual density	7.5	108	59 lbs.

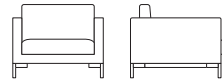
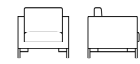

Order Code

<i>Example:</i>	69R-K1052/7
69R	Divina sofa, dual density
K1052/7	Topography, Canyon
<i>Example:</i>	68C-K1052/7
68C	Divina side cushion
K1052/7	Topography, Canyon

Specify:

1. Pattern number
2. R for dual density cushions
3. Textile selection

Side cushion, specify:

1. Pattern number
2. Textile selection

Ordering Information

Upholstery/COM information:

Prices shown include fabric or leather upholstery. Contact your Knoll representative for colors. Only approved KnollTextiles and Spinneybeck leathers may be ordered. Customer's Own Material is available pending approval. For approval requirements, processing instructions and ordering information please see page 18.

Optional Side Cushion:

One or two cushions can be specified for the standard lounge chair, settee and sofa. Side cushion is composed of polyurethane with polyester wrap. Since cushion is not fitted, it is available in fabric only.

Cal 133 Fire Code #:

The Divina Lounge collection complies with the California Technical Bulletin 133 standard if upholstered in Cal 133 approved upholstery. Specify suffix -C at end of pattern number and suffix -133 at end of textile or leather selection. For Cal 133 approval, leather units must be double upholstered: in the F187 fabric barrier and then in leather. Upcharge applies, see page 18.

Maintenance:

See pages 28-29.

Note:

The Divina Lounge Collection is Greenguard certified.

Construction

Frame:

Inner frame solid wood. Exposed metal frame and legs in heavy gauge tubular steel in polished chrome finish.

Feet:

Chrome-plated feet with polyurethane glides measuring 5.75" high.

Standard Cushions:

Seat cushion in polyurethane with polyester fiber wrap. Back cushion in polyurethane. Cushions are not reversible.

Dual Density Cushions:

Back cushion is polyurethane. Seat cushion is dual density foam: a soft foam core with a memory topper. Cushions are not reversible.

Upholstery:

Double-needled stitching on leather upholstery. Double-needled stitching on thin solid textiles, single-needled stitching on heavily ribbed fabrics and multicolor prints.

pattern no.	grades	COM	C	D	E	F	G	H	I	COL	V	W	X	Y
	A	B								U				
67S-()	\$5,253.	\$5,444.	\$5,633.	\$5,834.	\$6,001.	\$6,120.	\$6,326.	\$6,711.	\$7,001.	\$8,482.	\$9,178.	\$10,591.	\$10,885.	\$11,227.
67-()	6,054.	6,313.	6,559.	6,831.	7,056.	7,214.	7,492.	8,008.	8,393.	10,256.	11,195.	13,094.	13,490.	13,950.
67R-()	6,356.	6,626.	6,888.	7,174.	7,410.	7,575.	7,864.	8,410.	8,812.	10,768.	11,753.	13,747.	14,165.	14,647.

Approved KnollTextiles Grades/Fabrics

A Alignment # Beacon Bocce Cat's Cradle Chance Common Ground Commuter Cloth # Crossroad Delite Hourglass Mariner Monarch # Overture Prep # Presto # Sonnet Trophy Uni-Form	B continued Grandview Helios Holbrook Journey # Keaton Knoll Felt Knoll Hopsack Little Devil Melody Paradigm Petal Pusher Pogo Prairie Prim Radiance Ransom Roam Rush Hour Spark # Spree Summit Sutton # Bistro # Calypso Cameo Chroma Chronicle Diva Ferry Gala II	C Atlas Axiom Cairo Charm Circa Classic Boucle # Dahlia CR Durand Earthwork # Echo Empire Stripe Entourage Essence Fable CR Fibra Greenwich Hudson Hula Hoop Kaleidoscope CR Kora CR Lagos Lore CR Metro Milestone Moto CR Palisade Panache CR Pullman	C continued Quark Roundtrip Sahara Sequin CR Spot On Star Struck Stepping Stones Swing Tight Rope Tilden Tower Grid Wit Zari CR	D Coterie Eclat Weave Hologram Island Kabuki Masquerade Menagerie Origins Woodland Zoom	E Aegean Demure Highland Ikat Stripe Katazome Mamba Marquee Meroe Nature Walk Shima Tryst Whip	F Atelier Biscayne Calais Cotton Velvet Cornaro Icon Intrigue In Stitches Liberty Mod Plaid Rivington Soon Topography Totem	G Alter Ego Haze Melange Modern Tweed Petite Floral Serendipity Spencer Ultrasuede Arno # Constance Firefly Magritte Stretch Appeal Byron Cato Diamond Days Dynamic Knoll Velvet Olema Piper Rutledge Sandis Tudor Vermeer Zimba	H Arno # Constance Firefly Magritte Stretch Appeal	I Byron Cato Diamond Days Dynamic Knoll Velvet Olema Piper Rutledge Sandis Tudor Vermeer Zimba	U Vicenza # Volo # Acqua # Andes # Embossed Tipped España # Hand Tipped Velluto Pelle # Alaska # Amazon # Antique # Derby # Forte # Lucente Sabrina # Umbria # Approved for Cal 133 upholstery.	X Ducale # Ducale Velour # Cervo Copenhagen # Distressed # Marissa # Riva # Saddle #	Y Cervo Copenhagen # Distressed # Marissa # Riva # Saddle #
---	--	---	---	--	---	--	--	--	---	---	---	--

Spinneybeck Leather

U Vicenza # Volo # Acqua # Andes # Embossed Tipped España # Hand Tipped Velluto Pelle # Alaska # Amazon # Antique # Derby # Forte # Lucente Sabrina # Umbria # Approved for Cal 133 upholstery.	X Ducale # Ducale Velour # Cervo Copenhagen # Distressed # Marissa # Riva # Saddle #	W Alaska # Amazon # Antique # Derby # Forte # Lucente Sabrina # Umbria # Approved for Cal 133 upholstery.
---	---	---

Check with your KnollTextiles or Spinneybeck Representative for changes or additions.

Piero Lissoni

Divina® Lounge Seating

Designer(s):
Piero Lissoni, 2001

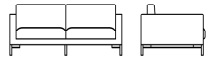
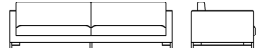

description	seat h	arm h	w	d	h	foam type	textile	req.	weight
							fabric yds.	leather sq. ft.	
68 Settee 	16 1/4"	24 1/4"	66"	35 1/2"	31 1/4"	standard	11.3	163	83 lbs.
	16 1/4"	24 1/4"	66"	35 1/2"	31 1/4"	dual density	11.3	163	83 lbs.
69 Sofa 	16 1/4"	24 1/4"	91"	35 1/2"	31 1/4"	standard	13.3	192	130 lbs.
	16 1/4"	24 1/4"	91"	35 1/2"	31 1/4"	dual density	13.3	192	130 lbs.

pattern no.	grades A	COM B	C	D	E	F	G	H	I	COL U	V	W	X	Y
68- ()	\$9,175.	\$9,572.	\$9,954.	\$10,374.	\$10,713.	\$10,961.	\$11,385.	\$12,180.	\$12,769.	\$15,655.	\$17,090.	\$20,015.	\$20,625.	\$21,332.
68R- ()	9,632.	10,051.	10,452.	10,892.	11,249.	11,511.	11,955.	12,790.	13,409.	16,436.	17,945.	21,017.	21,658.	22,400.
69- ()	10,378.	10,897.	11,389.	11,930.	12,373.	12,692.	13,233.	14,263.	15,028.	19,878.	21,734.	25,501.	26,291.	27,203.
69R- ()	10,897.	11,440.	11,959.	12,528.	12,991.	13,326.	13,894.	14,974.	15,777.	20,869.	22,817.	26,777.	27,605.	28,564.

Order Code

<i>Example:</i>	69R-K1052/7
69R	Divina sofa, dual density
K1052/7	Topography, Canyon

<i>Example:</i>	68C-K1052/7
68C	Divina side cushion
K1052/7	Topography, Canyon

Specify:

1. Pattern number
2. R for dual density cushions
3. Textile selection

Side cushion, specify:

1. Pattern number
2. Textile selection

Ordering Information

Upholstery/COM information:

Prices shown include fabric or leather upholstery. Contact your Knoll representative for colors. Only approved KnollTextiles and Spinneybeck leathers may be ordered. Customer's Own Material is available pending approval. For approval requirements, processing instructions and ordering information please see page 18.

Optional Side Cushion:

One or two cushions can be specified for the standard lounge chair, settee and sofa. Side cushion is composed of polyurethane with polyester wrap. Since cushion is not fitted, it is available in fabric only.

Cal 133 Fire Code #:

The Divina Lounge collection complies with the California Technical Bulletin 133 standard if upholstered in Cal 133 approved upholstery. Specify suffix -C at end of pattern number and suffix -133 at end of textile or leather selection. For Cal 133 approval, leather units must be double upholstered: in the F187 fabric barrier and then in leather. Upcharge applies, see page 18.

Maintenance:

See pages 28-29.

Note:

The Divina Lounge Collection is Greenguard certified.

Construction

Frame:

Inner frame solid wood. Exposed metal frame and legs in heavy gauge tubular steel in polished chrome finish.

Feet:

Chrome-plated feet with polyurethane glides measuring 5.75" high.

Standard Cushions:

Seat cushion in polyurethane with polyester fiber wrap. Back cushion in polyurethane. Cushions are not reversible.

Dual Density Cushions:

Back cushion is polyurethane. Seat cushion is dual density foam: a soft foam core with a memory topper. Cushions are not reversible.

Upholstery:

Double-needled stitching on leather upholstery. Double-needled stitching on thin solid textiles, single-needled stitching on heavily ribbed fabrics and multicolor prints.

Approved KnollTextiles Grades/Fabrics

A Alignment # Beacon Bocce Cat's Cradle Chance Common Ground Commuter Cloth # Crossroad Delite Hourglass Mariner Monarch # Overture Prep # Presto # Sonnet Trophy Uni-Form	B continued Grandview Helios Holbrook Journey # Keaton Knoll Felt Knoll Hopsack Little Devil Ludlow Melody Paradigm Petal Pusher Pogo Prairie Prim Radiance Ransom Roam Rush Hour Spark # Spree Summit Sutton # Bistro # Calypso Cameo Chroma Chronicle Diva Ferry Gala II	C Atlas Axiom Cairo Charm Circa Classic Boucle # Dahlia CR Durand Earthwork # Echo Empire Stripe Entourage Essence Fable CR Fibra Greenwich Hudson Hula Hoop Kaleidoscope CR Kora CR Lagos Lore CR Metro Milestone Moto CR Palisade Panache CR Pullman	C continued Quark Roundtrip Sahara Sequin CR Spot On Star Struck Stepping Stones Swing Tight Rope Tilden Tower Grid Wit Zari CR	D Coterie Eclat Weave Hologram Island Kabuki Masquerade Menagerie Origins Woodland Zoom	E Aegean Demure Highland Ikat Stripe Katazome Mamba Marquee Meroe Nature Walk Shima Tryst Whip	F Atelier Biscayne Calais Cotton Velvet Cornaro Icon Intrigue In Stitches Liberty Mod Plaid Rivington Soon Topography Totem	G Alter Ego Haze Melange Modern Tweed Petite Floral Serendipity Spencer Ultrasuede H Arno # Constance Firefly Magritte Stretch Appeal I Byron Cato Diamond Days Dynamic Knoll Velvet Olema Piper Rutledge Sandis Tudor Vermeer Zimba	U Vicenza # Volo # V Acqua # Andes # Embossed Tipped España # Hand Tipped Velluto Pelle # W Alaska # Amazon # Antique # Derby # Forte # Lucente Sabrina # Umbria # Approved for Cal 133 upholstery.	X Ducale # Ducale Velour # Y Cervo Copenhagen # Distressed # Marissa # Riva # Saddle #
---	--	---	---	--	---	--	--	---	---

Check with your KnollTextiles or Spinneybeck Representative for changes or additions.

Piero Lissoni

Divina® Lounge Seating

Designer(s):
Piero Lissoni, 2001



description	seat h	arm h	w	d	h	foam type	textile fabric yds.	req. leather sq. ft.	weight
68C Optional side cushion for standard chair, settee and sofa			21"	2 1/2"	13 1/4"	standard	1	n/a	5 lbs.
73 Ottoman			29 1/2"	29 1/2"	16"	standard	4.1	43	27 lbs.
			29 1/2"	29 1/2"	16"	dual density	4.1	43	27 lbs.

pattern no.	grades A	COM B	C	D	E	F	G	H	I	COL U	V	W	X	Y
68C-()	\$630.	\$665.	\$700.	\$737.	\$769.	\$794.	\$830.	\$906.	\$957.					
73-()	3,134.	3,270.	3,397.	3,536.	3,650.	3,737.	3,878.	4,144.	4,191.	4,345.	4,471.	5,043.	5,162.	5,300.
73R-()	3,290.	3,432.	3,567.	3,714.	3,832.	3,925.	4,072.	4,352.	4,401.	4,561.	4,697.	5,296.	5,419.	5,565.

Order Code

Example: 69R-K1052/7
69R Divina sofa, dual density
K1052/7 Topography, Canyon
Example: 68C-K1052/7
68C Divina side cushion
K1052/7 Topography, Canyon

Specify:

1. Pattern number
2. R for dual density cushions
3. Textile selection

Side cushion, specify:

1. Pattern number
2. Textile selection

Ordering Information

Upholstery/COM information:

Prices shown include fabric or leather upholstery. Contact your Knoll representative for colors. Only approved KnollTextiles and Spinneybeck leathers may be ordered. Customer's Own Material is available pending approval. For approval requirements, processing instructions and ordering information please see page 18.

Optional Side Cushion:

One or two cushions can be specified for the standard lounge chair, settee and sofa. Side cushion is composed of polyurethane with polyester wrap. Since cushion is not fitted, it is available in fabric only.

Cal 133 Fire Code #:

The Divina Lounge collection complies with the California Technical Bulletin 133 standard if upholstered in Cal 133 approved upholstery. Specify suffix -C at end of pattern number and suffix -133 at end of textile or leather selection. For Cal 133 approval, leather units must be double upholstered: in the F187 fabric barrier and then in leather. Upcharge applies, see page 18.

Maintenance:

See pages 28-29.

Note:

The Divina Lounge Collection is Greenguard certified.

Construction

Frame:

Inner frame solid wood. Exposed metal frame and legs in heavy gauge tubular steel in polished chrome finish.

Feet:

Chrome-plated feet with polyurethane glides measuring 5.75" high.

Standard Cushions:

Seat cushion in polyurethane with polyester fiber wrap. Back cushion in polyurethane. Cushions are not reversible.

Dual Density Cushions:

Back cushion is polyurethane. Seat cushion is dual density foam: a soft foam core with a memory topper. Cushions are not reversible.

Upholstery:

Double-needled stitching on leather upholstery. Double-needled stitching on thin solid textiles, single-needled stitching on heavily ribbed fabrics and multicolor prints.

Approved KnollTextiles Grades/Fabrics

A Alignment # Beacon Bocce Cat's Cradle Chance Common Ground Commuter Cloth # Crossroad Delite Hourglass Mariner Monarch # Overture Prep # Presto # Sonnet Trophy Uni-Form	B continued Grandview Helios Hollbrook Journey # Keaton Knoll Felt Knoll Hopsack Little Devil Ludlow Melody Paradigm Petal Pusher Pogo Prairie Prim Radiance Ransom Roam Rush Hour Spark # Spree Summit Sutton # Bistro # Calypso Cameo Chroma Chronicle Diva Ferry Gala II	C Atlas Axiom Cairo Charm Circa Classic Boucle # Dahlia CR Durand Earthwork # Echo Empire Stripe Entourage Essence Fable CR Fibra Greenwich Hudson Hula Hoop Kaleidoscope CR Kora CR Lagos Lore CR Metro Milestone Moto CR Palisade Panache CR Pullman	C continued Quark Roundtrip Sahara Sequin CR Spot On Star Struck Stepping Stones Swing Tight Rope Tilden Tower Grid Wit Zari CR	D Coterie Eclat Weave Hologram Island Kabuki Masquerade Menagerie Origins Woodland Zoom	E Aegean Demure Highland Ikat Stripe Katazome Mamba Marquee Meroe Nature Walk Shima Tryst Whip	F Atelier Biscayne Calais Cotton Velvet Cornaro Icon Intrigue In Stitches Liberty Mod Plaid Rivington Soon Topography Totem	G Alter Ego Haze Melange Modern Tweed Petite Floral Serendipity Spencer Ultrasuede	H Arno # Constance Firefly Magritte Stretch Appeal	I Byron Cato Diamond Days Dynamic Knoll Velvet Olema Piper Rutledge Sandis Tudor Vermeer Zimba	U Vicenza # Volo #	V Acqua # Andes # Embossed Tipped España # Hand Tipped Velluto Pelle #	W Alaska # Amazon # Antique # Derby # Forte # Lucente Sabrina # Umbria # Approved for Cal 133 upholstery.	X Ducale # Ducale Velour #	Y Cervo Copenhagen # Distressed # Marissa # Riva # Saddle #
---	---	---	---	--	---	--	---	--	---	---------------------------------	---	---	---	--



Spinneybeck Leather

Check with your KnollTextiles or Spinneybeck Representative for changes or additions.

Ross Lovegrove Sprite Armless Chair

Designer(s):
Ross Lovegrove, 2004



description	face/back	seat h	w	d	h	textile fabric yds.	leather sq ft.	weight
27C Same finish, face and back 	maple/maple	17"	22"	22"	32"	0.5	10	10 lbs.
	paint A/paint A	17"	22"	22"	32"	0.5	10	10 lbs.
	veneer/veneer	17"	22"	22"	32"	0.5	10	10 lbs.
27C Combination face and back 	maple/paint or paint/maple	17"	22"	22"	32"	0.5	10	10 lbs.
	paint A/paint B or paint B/Paint A	17"	22"	22"	32"	0.5	10	10 lbs.
	veneer/paint or paint/veneer	17"	22"	22"	32"	0.5	10	10 lbs.
Sprite Dolly 			14.5"	31"	26.5"			10 lbs.
27CGA Sprite Ganging Mechanism, Armless								
TR Sprite Tablet Arm			9 3/4"	13"				

Order Code

Example: **27CTR-KC-BL-C-K(VP-BLK)**

27C	Armless chair
TR	Tablet Arm (\$394 list upcharge)
KC	Rotary Maple face
BL	Black painted back
C	Chrome legs
K	Seat cushion
VP-BLK	Velluto Pelle, Black

Specify:

1. Pattern number
2. Optional tablet arm (\$394 list upcharge)
3. Finish selection, face
4. Finish selection, back
5. Leg finish (chrome only)
6. Seat cushion option
7. Textile selection

Ordering Information:

Maple finish:
☞ Rotary Maple (suffix KC)

Exotic Alpi and Veneer finishes:
Beech (suffix BN)
Cherry (suffix CY)
Walnut (suffix WA)
Zebra (suffix ZE)
Macasser Ebony (suffix ME)
Black and White Woodgrain (suffix WB)

Construction

Shell:
Molded plywood shell made of six layers of maple and three layers of adhesive.

Alpi Veneers:
Reconstituted veneers made of both plantation poplar and Obeche/Ayous, a bland African wood from well-managed sources with a long term forestry management plan.

Paint:
Smooth highly durable paint.

Edge finish:
On chairs painted one color, edge will be painted. For chairs in two-tone combination or with veneer option, edges are natural maple. For chairs in exotic Alpi veneer finish, edges are natural maple. For high use applications, maple or veneer options are recommended.

Base:
3/8" tubular steel with mirror chrome finish. Shell connected to the seat with four screws. Four rubber bumpers assure proper stacking.

Note:
The Sprite Chair in Maple, Exotic Alpi and Veneer finishes are Greenguard certified.

Upholstery:
Seat pad, upholstered in fabric or leather with urethane foam. Water based glue used for upholstery. Seat pad is attached to chair by four screws.

Stacking:
Armless Sprite chairs without seatpad can stack 8-10 high, with seatpad, 4-6.

Transportation Dolly:
Chrome plated steel frame with rubber wheels, 10-12 Sprite armless chairs can stack on a dolly. Dolly with 10 armless chairs measures: 53" h x 40" w x 22" d

Ganging Mechanism:
Armless mechanism measures 7.4". Device is constructed of a low durometer thermoplastic elastomer with a neodymium magnet. When not in use, the mechanism is easily stored (magnetized) to the underside of the chair.

Tablet Arm:
Tablet is right-handed with a fixed, chrome-plated arm. Integral to the frame, the tablet is black laminate with a 1/2" beveled birch edge. Tablet is factory installed and cannot be retrofitted in the field. For left handed version, please contact CPD. Sprite tablet arm passes BIFMA standards. Sprite chairs with tablet arm stack 4 high.

pattern no.	unuphol. (remove suffix -k)	grades A	COM B	C	D	E	F	G	H	I	COL U	V	W	X	Y
27C-(KC)-(KC)-C-K ☞	\$643.	\$804.	\$822.	\$836.	\$855.	\$868.	\$882.	\$898.	\$933.	\$957.	\$1,065.	\$1,132.	\$1,267.	\$1,297.	\$1,330.
27C-(-)(-)-C-K ☞	772.	935.	951.	968.	984.	999.	1,010.	1,028.	1,063.	1,087.	1,194.	1,260.	1,398.	1,428.	1,461.
27C-(-)(-)-C-K	1,080.	1,241.	1,257.	1,273.	1,291.	1,302.	1,318.	1,332.	1,368.	1,392.	1,501.	1,566.	1,705.	1,735.	1,768.
27C-(-)(-)-C-K	804.	967.	983.	999.	1,016.	1,031.	1,042.	1,060.	1,095.	1,118.	1,226.	1,293.	1,430.	1,460.	1,805.
27C-(-)(-)-C-K	862.	1,025.	1,042.	1,059.	1,075.	1,091.	1,101.	1,119.	1,151.	1,177.	1,288.	1,353.	1,490.	1,518.	1,552.
27C-(-)(-)-C-K	1,129.	1,291.	1,305.	1,324.	1,340.	1,355.	1,366.	1,385.	1,419.	1,442.	1,550.	1,617.	1,753.	1,783.	1,816.
27DOLLY	708.														
27CGA	28.														
TR	499.														

Approved KnollTextiles Grades/Fabrics

A Alignment # Bocce Cat's Cradle Common Ground Commuter Cloth # Crossroad Delite Dristi Foil Rap Heavy Metal Hourglass Mariner Monarch # Overture Prep # Presto # Sonnet Uni-Form	B Abacus # Argyle Backdrop Belize Bistro Boundary # Calypso Cameo Chronicle Close Knit Digital Tape Diva Dovetail # Fast Forward Ferry Forza Grande Grandview Helios Holbrook	C continued Cairo Charm Circa Classic Boucle Dahlia CR Decade Durand Earthwork # Echo Empire Stripe Essence Fable CR Prim Radiance Ransom Roam Rush Hour Spark # Spree Summit Sutton # Tabloid Tinge Versa Vinyl Westwood Wide Angle # Yeni Zipline	C continued Treble CR Wit Zari CR	D Compass CR Coterie Eclat Weave Hologram In The Loop Island Masquerade Menagerie Origins Woodland Zoom	E Aegean Cleo Demure Highland Ikati Stripe Juno Katazome Kimono Mamba Marquee Meroe Midpoint Nature Walk Sherman Shima Vatera Whip	F Atelier Biscayne Calais Cotton Velvet Glider Icon Intrigue In Stitches Liberty Mod Plaid Rivington Soon Topography Totem Tweed Frieze	G Alter Ego Andissa Gibson Haze Kamani Melange Modern Tweed Serendipity Spencer Straie Stripe Ultrasuede #	H Arno Bavaria Catwalk Constance Firefly Magritte Stretch Appeal	I Aswan Byron Cato Diamond Days Dynamic Ita Jaipur Knoll Velvet Limani North Island Olema Piper Rutledge Sandis Vermeer Zimba	U Vicenza # Volo #	V Acqua Andes Embossed Tipped España Hand Tipped Maremma Velluto Pelle	W Alaska Amazon Antique Derby Forte Lucente Sabrina	X Ducale Ducale Velour # Approved for Cal 133 upholstery.	Y Cervo Copenhagen Distressed Marissa Portofino Riva Saddle Torello
--	--	---	---	---	--	---	--	--	--	---------------------------------	--	---	---	--



Spinneybeck Leather

Check with your KnollTextiles or Spinneybeck Representative for changes or additions.

Ross Lovegrove Sprite Arm Chair

Designer(s):
Ross Lovegrove, 2004



description	face/back/arm	arm h	seat h	w	d	h	textile fabric yds.	leather sq ft.	weight
27A Same finish, face and back 	maple/maple/urethane arms	25 1/2"	17"	29"	22"	32"	0.5	10	13 lbs.
	paint A/paint A/urethane arms	25 1/2"	17"	29"	22"	32"	0.5	10	13 lbs.
	veneer/veneer/urethane arms	25 1/2"	17"	29"	22"	32"	0.5	10	13 lbs.
27A Combination, face and back 	maple/paint or paint/maple urethane arms	25 1/2"	17"	29"	22"	32"	0.5	10	13 lbs.
	paint A/paint B or paint B/paint A urethane arms	25 1/2"	17"	29"	22"	32"	0.5	10	13 lbs.
	veneer/paint or paint/veneer urethane arms	25 1/2"	17"	29"	22"	32"	0.5	10	13 lbs.
Sprite Dolly 				14.5"	31"	26.5"			10 lbs.
27AGA Sprite Ganging Mechanism, Arm									

Order Code

Example: **27C-KC-BL-C-BP-K(VP-BLK)**

27C	Armless chair
KC	Rotary Maple face
BL	Black painted back
C	Chrome legs
BP	Urethane arms
K	Seat cushion
VP-BLK	Velluto Pelle, Black

Specify:

1. Pattern number
2. Finish selection, face
3. Finish selection, back
4. Leg finish (chrome only)
5. Arm finish
6. Seat cushion option
7. Textile selection

Ordering Information:

Maple finish:
Rotary Maple (suffix KC)

Exotic Alpi and Veneer finishes:

- Beech (suffix BN)
- Cherry (suffix CY)
- Walnut (suffix WA)
- Zebra (suffix ZE)
- Macasser Ebony (suffix ME)
- Black and White Woodgrain (suffix WB)

Construction

Shell:
Molded plywood shell made of six layers of maple and three layers of adhesive.

Paint:
Smooth highly durable paint.

Edge finish:
On chairs painted one color, edge will be painted. For chairs in two-tone combination or with veneer option, edge will be natural maple. For chairs in Exotic Alpi veneer finish, edges are natural maple. For high use applications, maple or veneer options are recommended.

Base:
3/8" tubular steel with mirror chrome finish. Shell connected to the seat with four screws. Four rubber bumpers assure proper stacking.

Note:

The Sprite Chair in Maple, Exotic Alpi and Veneer finishes are Greenguard certified.

Upholstery:
Seat pad, upholstered in fabric or leather with urethane foam. Water based glue used for upholstery. Seat pad is attached to chair by four screws.

Armpads:
Black self skinning polyurethane pads (available on painted or maple/veneer chairs).

Stacking:
Arm Sprite chairs with or without seatpad can stack 4-6 high.

Transportation Dolly:
Chrome-plated steel frame with rubber wheels. 4-6 Sprite arm chairs stack on a dolly. Dolly with 10 armless chairs measures: 53" h x 40" w x 29" d

Ganging Mechanism
Arm mechanism measures 10". Device is constructed of a low durometer thermoplastic elastomer with a neodymium magnet. When not in use, the mechanism is easily stored (magnetized) to the underside of the chair.

pattern no.	unuphol. (remove suffix -k)	grades A	COM B	C	D	E	F	G	H	I	COL U	V	W	X	Y
27A-(KC)-(KC)-C-(BP)-K	\$876.	\$1,040.	\$1,059.	\$1,073.	\$1,095.	\$1,110.	\$1,119.	\$1,141.	\$1,175.	\$1,202.	\$1,312.	\$1,384.	\$1,525.	\$1,556.	\$1,588.
27A-(-)(-)-C-(BP)-K	944.	1,112.	1,130.	1,145.	1,167.	1,180.	1,190.	1,212.	1,246.	1,272.	1,385.	1,454.	1,594.	1,627.	1,648.
27A-(-)(-)-C-(BP)-K	1,256.	1,424.	1,441.	1,457.	1,476.	1,493.	1,502.	1,524.	1,557.	1,583.	1,695.	1,766.	1,906.	1,939.	1,972.
27A-(KC)-(-)-C-(BP)-K	980.	1,147.	1,167.	1,180.	1,203.	1,216.	1,226.	1,247.	1,283.	1,305.	1,420.	1,490.	1,631.	1,664.	1,697.
27A-(-)(-)-C-(BP)-K	1,036.	1,205.	1,221.	1,238.	1,257.	1,273.	1,283.	1,301.	1,335.	1,362.	1,475.	1,545.	1,687.	1,717.	1,751.
27A-(-)(-)-C-(BP)-K	1,310.	1,477.	1,496.	1,510.	1,531.	1,546.	1,556.	1,578.	1,613.	1,636.	1,748.	1,819.	1,960.	1,993.	2,026.
27DOLLY	708.														
27AGA	28.														

Approved KnollTextiles Grades/Fabrics

A Alignment # Bocce Cat's Cradle Common Ground Commuter Cloth # Crossroad Delite Dristi Foil Rap Heavy Metal Hourglass Mariner Monarch # Overture Prep # Presto # Sonnet Uni-Form	B continued Keaton Knoll Felt # Knoll Hopsack # Ludlow Little Devil Melody Mini Stitch # Paradigm Petal Pusher Pogo Prairie Prim Radiance Ransom Roam Rush Hour Spark # Spree Summit Sutton # Tabloid Tinge Versa Vinyl Westwood Wide Angle # Yeni Zipline	C continued Cairo Charm Circa Classic Boucle Dahlia CR Decade Durand Earthwork # Echo Empire Stripe Essence Fable CR Fibra Greenwich Hudson Hula Hoop Kaleidoscope CR Lagos Legend CR Lore CR Metro Milestone Moto CR Palisade Posh Pullman Quark Roundtrip Sinclair Smart Spectator Spot On Star Struck Stepping Stones Tilden Tower Grid	C continued Treble CR Wit Zari CR D Compass CR Coterie In Stitches Hologram In The Loop Island Masquerade Menagerie Origins Woodland Zoom E Aegean Cleo Demure Highland Ikat Stripe Juno Katazome Kimono Mamba Marquee Midpoint Nature Walk Sherman Shima Vatera Whip	F Atelier Biscayne Calais Cotton Velvet Glider Icon Intrigue In Stitches Liberty Mod Plaid Rivington Soon Topography Totem Tweed Frieze G Alter Ego Andissa Gibson Haze Kamani Melange Modern Tweed Serendipity Spencer Straie Stripe Ultrasuede #	H Arno Bavaria Catwalk Constance Firefly Magritte Stretch Appeal I Aswan Byron Cato Diamond Days Dynamic Ita Jaipur Knoll Velvet Limani North Island Olema Piper Rutledge Sandis Vermeer Zimba	U Vicenza # Volo # V Acqua Andes Embossed Tipped España Hand Tipped Maremma Velluto Pelle W Alaska Amazon Antique Derby Forte Lucente	W continued Sabrina X Ducale Ducale Velour Y Cervo Copenhagen Distressed Lucca Marissa Portofino Riva Saddle Torello
---	---	---	--	---	--	---	---

Spinneybeck Leather

U Vicenza # Volo #	V Acqua Andes Embossed Tipped España Hand Tipped Maremma Velluto Pelle	W Alaska Amazon Antique Derby Forte Lucente	W continued Sabrina X Ducale Ducale Velour Y Cervo Copenhagen Distressed Lucca Marissa Portofino Riva Saddle Torello
---------------------------------	--	--	---





Approved for Cal 133 upholstery.

Check with your KnollTextiles or Spinneybeck Representative for changes or additions.

Vico Magistretti Cirene Stacking Chair

Designer(s):
Vico Magistretti, 1999

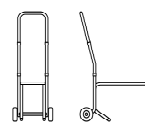

description	seat h	arm h	w	d	h	weight
46A Arm chair, unupholstered 	18"	24 7/8"	22 7/8"	20 1/2"	29 1/2"	14 lbs.
	18"	24 7/8"	22 7/8"	20 1/2"	29 1/2"	14 lbs.
46A-U Arm chair, upholstered 	18"	24 7/8"	22 7/8"	20 1/2"	29 1/2"	15 lbs.
46C Armless chair, unupholstered 	18"		21"	21 1/4"	29 1/2"	11 lbs.
	18"		21"	21 1/4"	29 1/2"	11 lbs.
46C-U Armless chair, upholstered 	18"		21"	21 1/4"	29 1/2"	13 lbs.
59Dolly Dolly for 8 Cirene chairs, unupholstered 			15 7/8"	27 1/2"	43 1/8"	7 lbs.
L Arm / Armless chair with ganging mechanism, installed, stored under seat						

pattern no.	unuphol.	fabric	leather
46A(CG,W)	\$1,348.		
46A-(KC,WE)	1,418.		
46A-U ()		1,825.	2,546.
46C-(CG,W)	1,118.		
46C-(KC,WE)	1,184.		
46C-U ()		1,697.	2,427.
59Dolly	1,322.		
L	141.		

Order Code	Ordering Information
<i>Example:</i> 46C-W-L	<i>Melamine Shell Finishes:</i>
46C Cirene armless stacking chair	White (suffix W)
W White shell	<i>Paint Shell Finishes:</i>
L With ganging mechanism	Charcoal (suffix CC)
<i>Example:</i> 46A-U-MA	<i>Veneer Shell Finishes:</i>
46A-U Cirene arm chair, upholstered	Maple (suffix KC)
MA Brown Leather	Wengè-stained oak (suffix WE)

- Specify:
1. Pattern number
 2. Shell color
 3. Ganging option (suffix L)



- For leather option, specify:
1. Pattern number
 2. Textile selection

Construction	Approved Textiles
<i>Description:</i> Molded plywood shell in natural veneer finish (maple, wengè); smooth paint finish (charcoal) melamine finish with plywood edge (white). Frame is chrome-plated tubular steel. Arm chair features black polypropylene molded armpads. Armpads are not removable and cannot be retrofitted.	<i>Trevira textile colors:</i> Plain weave cross-dye fabrics: Blue (F941741) Orange (F941511) Red (F941521)
<i>Fabric & Leather cover:</i> Cirene can be ordered with full cover. Plywood-shell is covered with pad and fabric/leather is attached with velcro on the underside of the chair. Cover is not removable.	<i>Leather colors:</i> Tabacco (TA) Black (NE) <i>For samples of leathers and fabrics, please contact your KnollStudio sales representative.</i>

Marco Maran Gigi® Arm Chair

Designer(s):
Marco Maran, 2000



description	seat h	arm h	w	d	h	textile fabric yds.	weight
87A-K-S Arm chair with seat pad, stacking 	18"	26½"	19¾"	20"	34¼"	0.7	16 lbs.
87Dolly Dolly for 10 Gigi chairs 			19.2"	31"	26½"		11 lbs.
87Tablet Folding tablet arm, right for armless chair				9¾"	12"		
87GA Gigi ganging mechanism							

pattern no.	unuphol.	A	COM B	C	D	E	F	G	H	I
87A-K-S-(-)(-)		\$1,125.	\$1,143.	\$1,160.	\$1,178.	\$1,193.	\$1,205.	\$1,223.	\$1,259.	\$1,286.
87Dolly	774.									
87TABLET	317.									
87GA	38.									





Order Code

<i>Example:</i> 87A-014	Gigi arm stacking chair
87A	Gigi arm stacking chair
014	Black shell

Specify:

1. Pattern number
2. Shell finish
3. Textile selection

Ordering Information

Shell finishes:
 Black (suffix 014)
 Graphite (suffix 003)
 Mango (suffix 006)
 Navy (suffix 012)
 Red (suffix 007)
 Seafoam (suffix 010)
 White (suffix 001)

 *KnollStudio 20-Day Program:*
 Gigi arm chair is available on the 20-day program, unupholstered, in white, graphite, black, red and navy shell finishes. For specific ordering information consult pages 27-28.

Upholstery/Com information:
 Prices shown include fabric or leather upholstery. Contact your Knoll representative for colors. Only approved KnollTextiles and Spinneybeck leathers may be ordered.

Customer's Own Material is available pending approval. For approval requirements, processing instructions and ordering information, please see page 18.

Maintenance:
 See pages 28-29.

Stacking feature:
 Gigi armless unupholstered chairs stack 4 high on floor.
 Gigi armless chairs with seat pad and bumper stack 4 high on floor.
 Gigi armless chairs with seat pad and stacking bumper stack 8-10 high on a dolly.
 Gigi arm chair with seat pad and stacking bumper stack 4 high on floor and dolly.
 Gigi arm chair stacks 4 high on floor and dolly.
 Gigi chairs with seatpad without bumper (87CK-N, 87AK-N) do not stack.

Note:
 The Gigi Chair is Greenguard certified.

Construction

Description:
 Coloured polypropylene shell on a chrome-plated base. Arm chairs have black polypropylene molded arm pads. Chair back flexes for comfort. Gigi chairs are easily cleaned in food areas and work with a booster seat.

Seat Pad:
 Seat pad is permanently attached to the seat with bolts in the factory. Seat pad is not retrofittable in the field. Constructed of ABS with high resilient foam.

Stacking bumper:
 Black flexible urethane stacking pad secured between base and shell.

Transportation Dolly:
 Chrome plated steel frame with rubber wheels. 10 Gigi armless chairs can be stacked on the dolly. Dollies can stack three high for compact storage. Dolly with 10 chairs will measure 56.3" h, 19.75" w, 41" d. Dolly does not lock.

Approved KnollTextiles Grades/Fabrics

Tablet Arm:
 The tablet attaches to the chair frame underneath the seat. It is aligned with the front leg and has a flip up mechanism. Tablet is black melamine. Steel support with chrome finish. Tablet arm can be used with armless chair only. Gigi with tablet can be stacked 4 high on the floor and on the dolly.

Note:
 Tablet arm option is not offered with stacking bumper.

Ganging Mechanism:
 The easy-to-detach ganging mechanism links two adjoining frames at the front legs or rear legs. Ganging mechanism consists of black molded polypropylene. Chairs with ganging mechanism can be stacked. Tablet arm ships separate from the chair and can be retrofitted in the field. Arm chairs can not be ganged with armless chairs.



A Alignment Bocce Cat's Cradle Chance Common Ground Commuter Cloth Crossroad Delite Dristi Foil Rap Heavy Metal Hourglass Mariner Monarch Overture Prep Presto Soliloquy Sonnet Uni-Form	B Abacus Argyle Belize Bistro Calypso Cameo Chroma Chronicle Close Knit Diva Dovetail Fast Forward Ferry Gala II Grande Grandview Helios Holbrook	C Abacus Argyle Belize Bistro Calypso Cameo Chroma Chronicle Close Knit Diva Dovetail Fast Forward Ferry Gala II Grande Grandview Helios Holbrook	C continued Journey Keaton Knoll Felt Knoll Hopsack Little Devil Ludlow Melody Mini Stitch Paradigm Petal Pusher Pogo Prairie Prim Radiance Ransom Roam Rush Hour Spark Spree Summit Sutton Tabloid Tinge Venue Versa Westwood Wide Angle Yeni Zipline	C continued Dahlia CR Decade Dune Durand Earthwork Echo Enmesh Entourage Essence Fable CR Fibra Greenwich Hudson Hula Hoop Kaleidoscope CR Kaya CR Kora CR Lagos Legend CR Lore CR Metro Milestone Moto CR Noble Palisade Panache CR Pullman Quark Roundtrip Sequin CR Smart Spectator Spot On Star Struck Stepping Stones Swing Tight Rope Tilden Tower Grid	C continued Treble CR Wit Zari CR D Compass CR Coterie Eclat Weave Hologram Island In The Loop Masquerade Menagerie Origins Woodland Zoom E Aegean Cleo Demure Highland Ikat Stripe Juno Katazome Kimono Mamba Marquee Meroe Midpoint Nature Walk Sherman Tryst Vatera Whip	F Atelier Biscayne Calais Cotton Velvet Cornaro Glider Icon Intrigue In Stitches Mod Plaid Liberty Rivington Soon Topography Totem Tweed Frieze G Alter Ego Andissa Gibson Haze Kamani Melange Modern Tweed Serendipity Straie Stripe Ultrasuede	H Arno Bavaria Catwalk Constance Firefly Magritte Stretch Appeal I Aswan Byron Cato Cummings Diamond Days Dynamic Ita Jaipur Mepal Olema Piper Rutledge Sandis Vermeer Zimba
---	--	--	--	---	---	---	---

Check with your KnollTextiles representative for changes or additions.





Marco Maran Gigi® Armless Chair

Designer(s):
Marco Maran, 2000



description	seat h	w	d	h	textile fabric	weight
					yds.	
87C Armless chair, stacking 	18"	19 3/4"	20"	34 1/4"		11 lbs.
87C-K-N Armless chair with seat pad, non-stacking 	18"	19 3/4"	20"	34 1/4"	0.7	12 lbs.

pattern no.	unuphol.	A	COM B	C	D	E	F	G	H	I
87C-() 	\$465.									
87C-K-N-()-()		756.	773.	789.	808.	824.	835.	855.	889.	917.

Order Code	Ordering Information	Construction
<i>Example:</i> 87C-K-S-010-K1207/1	<i>Shell finishes:</i>  Black (suffix 014)  Graphite (suffix 003) Mango (suffix 006)  Navy (suffix 012)  Red (suffix 007) Seafoam (suffix 010)  White (suffix 001) <i>KnollStudio 20-Day Program:</i> Gigi armless chair is available on the 20-day program, unupholstered, in white, graphite, black, red and navy shell finishes. For specific ordering information consult pages 27-28. <i>Upholstery/Com information:</i> Prices shown include fabric or leather upholstery. Contact your Knoll representative for colors. Only approved KnollTextiles and Spinneybeck leathers may be ordered. Customer's Own Material is available pending approval. For approval requirements, processing instructions and ordering information, please see page 18.	<i>Maintenance:</i> See pages 28-29. <i>Stacking feature:</i> Gigi armless unupholstered chairs stack 4 high on floor. Gigi armless chairs with seat pad and bumper stack 4 high on floor. Gigi armless chairs with seat pad and stacking bumper stack 8-10 high on a dolly. Gigi arm chair with seat pad and stacking bumper stack 4 high on floor and dolly. Gigi arm chair stacks 4 high on floor and dolly. Gigi chairs with seatpad without bumper (87CK-N, 87AK-N) do not stack. <i>Note:</i> The Gigi Chair is Greenguard certified.
87C-K-S Gigi armless stacking chair with seat pad		<i>Description:</i> Coloured polypropylene shell on a chrome-plated base. Arm chairs have black polypropylene molded arm pads. Chair back flexes for comfort. Gigi chairs are easily cleaned in food areas and work with a booster seat. <i>Seat Pad:</i> Seat pad is permanently attached to the seat with bolts in the factory. Seat pad is not retrofittable in the field. Constructed of ABS with high resilient foam. <i>Stacking bumper:</i> Black flexible urethane stacking pad secured between base and shell. <i>Transportation Dolly:</i> Chrome plated steel frame with rubber wheels. 10 Gigi chairs can be stacked on the dolly. Dollies can stack three high for compact storage. Dolly with 10 chairs will measure 56.3" h, 19.75" w, 41" d. Dolly does not lock.
010 Seafoam shell		
K1207/1 Knoll Felt, Ivory		

- Specify:
1. Pattern number
 2. Shell finish
 3. Textile finish

Approved KnollTextiles Grades/Fabrics



<i>Tablet Arm:</i> The tablet attaches to the chair frame underneath the seat. It is aligned with the front leg and has a flip up mechanism. Tablet is black melamine. Steel support with chrome finish. Tablet arm can be used with armless chair only. Gigi with tablet can be stacked 4 high on the floor and on the dolly. <i>Note:</i> Tablet arm option is not offered with stacking bumper. <i>Ganging Mechanism:</i> The easy-to-detach ganging mechanism links two adjoining frames at the front legs or rear legs. Ganging mechanism consists of black molded polypropylene. Chairs with ganging mechanism can be stacked. Tablet arm ships separate from the chair and can be retrofitted in the field. Arm chairs can not be ganged with armless chairs.	A Alignment Bocce Cat's Cradle Chance Common Ground Commuter Cloth Crossroad Delite Dristi Foil Rap Heavy Metal Hourglass Mariner Monarch Overture Prep Presto Soliloquy Sonnet Uni-Form	B continued Journey Keaton Knoll Felt Knoll Hopsack Little Devil Ludlow Melody Mini Stitch Paradigm Petal Pusher Pogo Prairie Prim Radiance Ransom Roam Rush Hour Spark Spree Summit Sutton Tabloid Tinge Venue Versa Westwood Wide Angle Yeni Zipline	C continued Dahlia CR Decade Dune Durand Earthwork Echo Enmesh Entourage Essence Fable CR Fibra Greenwich Hudson Hula Hoop Kaleidoscope CR Kora CR Lagos Legend CR Lore CR Metro Milestone Moto CR Noble Palisade Panache CR Pullman Quark Roundtrip Sequin CR Smart Spectator Spot On Star Struck Stepping Stones Swing Tight Rope Tilden Tower Grid	D continued Treble CR Wit Zari CR D Compass CR Coterie Eclat Weave Hologram Island In The Loop Masquerade Menagerie Origins Woodland Zoom	E Aegean Cleo Demure Highland Ikat Stripe Juno Katazome Kimono Mamba Marquee Meroe Midpoint Nature Walk Sherman Tryst Vatera Whip	F Atelier Biscayne Calais Cotton Velvet Cornaro Glider Icon Intrigue In Stitches Mod Plaid Liberty Rivington Soon Topography Totem Tweed Frieze	G Alter Ego Andissa Gibson Haze Kamani Melange Modern Tweed Serendipity Straie Stripe Ultrasuede	H Arno Bavaria Catwalk Constance Firefly Magritte Stretch Appeal I Aswan Byron Cato Cummings Diamond Days Dynamic Ita Jaipur Mepal Olema Piper Rutledge Sandis Vermeer Zimba
---	---	--	--	--	---	--	---	---

Check with your KnollTextiles representative for changes or additions.





Marco Maran Gigi® Armless Chair

Designer(s):
Marco Maran, 2000



description	seat h	w	d	h	textile fabric yds.	weight
87C-K-S Armless chair with seat pad, stacking 	18"	19 3/4"	20"	34 1/4"	0.7	13 lbs.
87Dolly Dolly for 10 Gigi chairs 		19.2"	31"	26 1/2"		11 lbs.
87Tablet Folding tablet arm, right for armless chair			9 1/4"	12"		
87GA Gigi ganging mechanism						

pattern no.	unuphol.	A	COM B	C	D	E	F	G	H	I
87C-K-S(-)(-)		\$859.	\$879.	\$894.	\$914.	\$929.	\$940.	\$959.	\$995.	\$1,022.
87Dolly	774.									
87TABLET	317.									
87GA	38.									

Order Code	Ordering Information	Construction	
<i>Example:</i> 87C-K-S-010-K1207/1	<i>Shell finishes:</i>  Black (suffix 014)  Graphite (suffix 003) Mango (suffix 006)  Navy (suffix 012)  Red (suffix 007) Seafoam (suffix 010)  White (suffix 001) <i>KnollStudio 20-Day Program:</i> Gigi armless chair is available on the 20-day program, unupholstered, in white, graphite, black, red and navy shell finishes. For specific ordering information consult pages 27-28. <i>Upholstery/Com information:</i> Prices shown include fabric or leather upholstery. Contact your Knoll representative for colors. Only approved KnollTextiles and Spinneybeck leathers may be ordered. Customer's Own Material is available pending approval. For approval requirements, processing instructions and ordering information, please see page 18.	<i>Maintenance:</i> See pages 28-29. <i>Stacking feature:</i> Gigi armless unupholstered chairs stack 4 high on floor. Gigi armless chairs with seat pad and bumper stack 4 high on floor. Gigi armless chairs with seat pad and stacking bumper stack 8-10 high on a dolly. Gigi arm chair with seat pad and stacking bumper stack 4 high on floor and dolly. Gigi arm chair stacks 4 high on floor and dolly. Gigi chairs with seatpad without bumper (87CK-N, 87AK-N) do not stack. <i>Note:</i> The Gigi Chair is Greenguard certified.	<i>Description:</i> Coloured polypropylene shell on a chrome-plated base. Arm chairs have black polypropylene molded arm pads. Chair back flexes for comfort. Gigi chairs are easily cleaned in food areas and work with a booster seat. <i>Seat Pad:</i> Seat pad is permanently attached to the seat with bolts in the factory. Seat pad is not retrofittable in the field. Constructed of ABS with high resilient foam. <i>Stacking bumper:</i> Black flexible urethane stacking pad secured between base and shell. <i>Transportation Dolly:</i> Chrome plated steel frame with rubber wheels. 10 Gigi chairs can be stacked on the dolly. Dollies can stack three high for compact storage. Dolly with 10 chairs will measure 56.3" h, 19.75" w, 41" d. Dolly does not lock.



- Specify:
1. Pattern number
 2. Shell finish
 3. Textile finish

Approved KnollTextiles Grades/Fabrics

<i>Tablet Arm:</i> The tablet attaches to the chair frame underneath the seat. It is aligned with the front leg and has a flip up mechanism. Tablet is black melamine. Steel support with chrome finish. Tablet arm can be used with armless chair only. Gigi with tablet can be stacked 4 high on the floor and on the dolly. <i>Note:</i> Tablet arm option is not offered with stacking bumper. <i>Ganging Mechanism:</i> The easy-to-detach ganging mechanism links two adjoining frames at the front legs or rear legs. Ganging mechanism consists of black molded polypropylene. Chairs with ganging mechanism can be stacked. Tablet arm ships separate from the chair and can be retrofitted in the field. Arm chairs can not be ganged with armless chairs.	A Alignment Bocce Cat's Cradle Chance Common Ground Commuter Cloth Crossroad Delite Dristi Foil Rap Heavy Metal Hourglass Mariner Monarch Overture Prep Presto Soliloquy Sonnet Uni-Form	B continued Journey Keaton Knoll Felt Knoll Hopsack Little Devil Ludlow Melody Mini Stitch Paradigm Petal Pusher Pogo Prairie Prim Radiance Ransom Roam Rush Hour Spark Spree Summit Sutton Tabloid Tinge Venue Versa Westwood Wide Angle Yeni Zipline	C continued Dahlia CR Decade Dune Durand Earthwork Echo Enmesh Entourage Essence Fable CR Fibra Greenwich Hudson Hula Hoop Kaleidoscope CR Kora CR Lagos Legend CR Lore CR Metro Milestone Moto CR Noble Palisade Panache CR Pullman Quark Roundtrip Sequin CR Smart Spectator Spot On Star Struck Stepping Stones Swing Tight Rope Tilden Tower Grid	D continued Treble CR Wit Zari CR D Compass CR Coterie Eclat Weave Hologram Island In The Loop Masquerade Menagerie Origins Woodland Zoom	E Aegean Cleo Demure Highland Ikat Stripe Juno Katazome Kimono Mamba Marquee Meroe Midpoint Nature Walk Sherman Tryst Vatera Whip	F Atelier Biscayne Calais Cotton Velvet Cornaro Glider Icon Intrigue In Stitches Mod Plaid Liberty Rivington Soon Topography Totem Tweed Frieze	G Alter Ego Andissa Gibson Haze Kamani Melange Modern Tweed Serendipity Straie Stripe Ultrasuede	H Arno Bavaria Catwalk Constance Firefly Magritte Stretch Appeal I Aswan Byron Cato Cummings Diamond Days Dynamic Ita Jaipur Mepal Olema Piper Rutledge Sandis Vermeer Zimba
---	---	--	--	--	---	--	---	---

Check with your KnollTextiles representative for changes or additions.

Marco Maran
Gigi® Armless Chair with Sled Base

	description	seat h	w	d	h	textile fabric yds.	weight
<i>Designer(s):</i> Marco Maran, 2000 	87CSB Armless chair with sled base, stacking 	18"	21 3/8"	21"	34 1/4"	0.7	14 lbs.
	87CSB-K-N Armless chair with sled base, seat pad upholstery, non-stacking 	18"	21 3/8"	21"	34 1/4"	0.7	14 lbs.

pattern no.	unuphol.	A	COM B	C	D	E	F	G	H	I
87CSB-()	\$641.									
87CSB-K-N-()-()		930.	948.	966.	984.	999.	1,010.	1,030.	1,065.	1,093.

Order Code

<i>Example:</i> 87CSB-K-N-010-K1621/21
87CSB-K-N Gigi armless chair with sled base, non-stacking with seat pad
010 Seafoam shell
K1621/21 Classic Boucle, Smoke

Specify:

1. Pattern number
2. Shell finish
3. Textile selection

Ordering Information

Shell finishes:

- Black (suffix 014)
- Graphite (suffix 003)

Mango (suffix 006)

- Navy (suffix 012)
- Red (suffix 007)

Seafoam (suffix 010)

- White (suffix 001)

Upholstery/COM information:

Prices shown include fabric or leather upholstery. Contact your Knoll representative for colors. Only approved KnollTextiles and Spinneybeck leathers may be ordered.

Customer's Own Material is available pending approval. For approval requirements, processing instructions and ordering information, please see page 18.

Construction

Description:

Coloured polypropylene shell on a chrome-plated base. Arm chairs have black polypropylene molded arm pads. Chair back flexes for comfort. Gigi chairs are easily cleaned in food areas and work with a booster seat.

Seat Pad:

Seat pad is permanently attached to the seat with bolts in the factory. Seat pad is not retrofittable in the field. Constructed of ABS with high resilient foam.

Stacking bumper:

Black flexible urethane stacking pad secured between base and shell.

Transportation Dolly:

Chrome plated steel frame with rubber wheels. 10 Gigi chairs can be stacked on the dolly. Dollies can stack three high for compact storage. Dolly with 10 chairs will measure 56.3" h, 19.75" w, 41" d. Dolly does not lock.



Approved KnollTextiles Grades/Fabrics

A Alignment Bocce Cat's Cradle Chance Common Ground Commuter Cloth Crossroad Delite Dristi Foil Rap Heavy Metal Hourglass Mariner Monarch Overture Prep Presto Soliloquy Sonnet Uni-Form	B Abacus Argyle Belize Bistro Calypso Cameo Chroma Chronicle Close Knit Diva Dovetail Fast Forward Ferry Gala II Grande Grandview Helios Holbrook	B continued Journey Keaton Knoll Felt Knoll Hopsack Little Devil Ludlow Melody Mini Stitch Paradigm Petal Pusher Pogo Prairie Prim Radiance Ransom Roam Rush Hour Spark Spree Summit Sutton Tabloid Tinge Venue Versa Westwood Wide Angle Yeni Zipline	C Atlas Axiom Baxter Cairo Charm Circa Classic Boucle Tower Grid	C continued Dahlia CR Decade Dune Durand Earthwork Echo Enmesh Entourage Essence Fable CR Fibra Greenwich Hudson Hula Hoop Kaleidoscope CR Kora CR Lagos Legend CR Lore CR Metro Milestone Moto CR Noble Palisade Panache CR Pullman Quark Roundtrip Sequin CR Smart Spectator Spot On Star Struck Stepping Stones Swing Tight Rope Tilden Tower Grid	C continued Treble CR Wit Zari CR	D Compass CR Coterie Eclat Weave Hologram Island In The Loop Masquerade Menagerie Origins Woodland Zoom	E Aegean Cleo Demure Highland Ikat Stripe Juno Katazome Kimono Mamba Marquee Meroe Midpoint Nature Walk Sherman Tryst Vatera Whip	F Atelier Biscayne Calais Cotton Velvet Cornaro Glider Icon Intrigue In Stitches Mod Plaid Liberty Rivington Soon Topography Totem Tweed Frieze	G Alter Ego Andissa Gibson Haze Kamani Melange Modern Tweed Serendipity Straie Stripe Ultrasuede	H Arno Bavaria Catwalk Constance Firefly Magritte Stretch Appeal	I Aswan Byron Cato Cummings Diamond Days Dynamic Ita Jaipur Mepal Olema Piper Rutledge Sandis Vermeer Zimba
---	--	--	---	--	---	---	---	--	---	--	---





Check with your KnollTextiles representative for changes or additions.

Marco Maran

Gigi® Armless Chair with Sled Base

	description	height, seat	width	depth	height	textile fabric yds.	weight
<i>Designer(s):</i> Marco Maran, 2000	87CSB-K-S Armless chair with sled base, seat pad upholstery, stacking	18"	21 7/8"	21"	34 1/4"	0.7	14 lbs.
							
	87Dolly Dolly for 10 Gigi chairs		19.2"	31"	26 1/2"		11 lbs.
							

pattern no.	unuphol.	A	COM B	C	D	E	F	G	H	I
87CSB-K-S-()-()		\$1,035.	\$1,055.	\$1,069.	\$1,090.	\$1,103.	\$1,114.	\$1,135.	\$1,171.	\$1,197.
87Dolly	774.									

Order Code	Ordering Information	Construction
<i>Example:</i> 87CSB-K-N-010-K1621/21	<i>Shell finishes:</i>	<i>Description:</i>
87CSB-K-N Gigi armless chair with sled base, non-stacking with seat pad	<ul style="list-style-type: none">  Black (suffix 014)  Graphite (suffix 003) Mango (suffix 006)  Navy (suffix 012)  Red (suffix 007) Seafoam (suffix 010)  White (suffix 001) 	Coloured polypropylene shell on a chrome-plated base. Arm chairs have black polypropylene molded arm pads. Chair back flexes for comfort. Gigi chairs are easily cleaned in food areas and work with a booster seat.
010 Seafoam shell	<i>Stacking feature:</i>	<i>Seat Pad:</i>
K1621/21 Classic Boucle, Smoke	Gigi with sled base, armless, unupholstered stack 4 high on floor.	Seat pad is permanently attached to the seat with bolts in the factory. Seat pad is not retrofittable in the field. Constructed of ABS with high resilient foam.
	Gigi with sled base, armless, seat pad upholstery with stacking bumper stack 4 high on floor.	<i>Stacking bumper:</i>
	Gigi with sled base, armless, seat pad upholstery with stacking bumper stack 8-10 high on dolly.	Black flexible urethane stacking pad secured between base and shell.
	<i>Upholstery/COM information:</i>	<i>Transportation Dolly:</i>
	Prices shown include fabric or leather upholstery. Contact your Knoll representative for colors. Only approved KnollTextiles and Spinneybeck leathers may be ordered.	Chrome plated steel frame with rubber wheels. 10 Gigi chairs can be stacked on the dolly. Dollies can stack three high for compact storage. Dolly with 10 chairs will measure 56.3" h, 19.75" w, 41" d. Dolly does not lock.
	Customer's Own Material is available pending approval. For approval requirements, processing instructions and ordering information, please see page 18.	





Specify:

1. Pattern number
2. Shell finish
3. Textile selection

Approved KnollTextiles Grades/Fabrics					
A	B	C	D	F	H
Alignment	Journey	Dahlia CR	Treble CR	Atelier	Arno
Bocce	Keaton	Decade	Wit	Biscayne	Bavaria
Cat's Cradle	Knoll Felt	Dune	Zari CR	Calais Cotton	Catwalk
Chance	Knoll Hopsack	Durand		Velvet	Constance
Common Ground	Little Devil	Earthwork	D	Cornaro	Firefly
Commuter Cloth	Ludlow	Echo	Compass CR	Glider	Magritte
Crossroad	Melody	Enmesh	Coterie	Icon	Stretch Appeal
Delite	Mini Stitch	Entourage	Eclat Weave	Intrigue	
Dristi	Paradigm	Essence	Hologram	In Stitches	I
Foil Rap	Petal Pusher	Fable CR	Island	Mod Plaid	Aswan
Heavy Metal	Pogo	Fibra	In The Loop	Liberty	Byron
Hourglass	Prairie	Greenwich	Masquerade	Rivington	Cato
Mariner	Prim	Hudson	Menagerie	Soon	Cummings
Monarch	Radiance	Hula Hoop	Origins	Topography	Diamond Days
Overture	Ransom	Kaleidoscope CR	Woodland	Totem	Dynamic
Prep	Roam	Kora CR	Zoom	Tweed Frieze	Ita
Presto	Rush Hour	Lagos			Jaipur
Soliloquy	Spark	Legend CR	E		Mepal
Sonnet	Spree	Lore CR	Aegean	Alter Ego	Olema
Uni-Form	Summit	Metro	Cleo	Andissa	Piper
	Sutton	Milestone	Demure	Gibson	Rutledge
B	Tabloid	Moto CR	Highland	Haze	Sandis
Abacus	Tinge	Noble	Ikate Stripe	Kamani	Vermeer
Argyle	Venue	Palisade	Juno	Melange	Zimba
Belize	Versa	Panache CR	Katazome	Modern Tweed	
Bistro	Westwood	Pullman	Kimono	Serendipity	
Calypso	Wide Angle	Quark	Mamba	Straie Stripe	
Cameo	Yeni	Roundtrip	Marquee	Ultrasuede	
Chroma	Zipline	Sequin CR	Meroe		
Chronicle		Smart	Midpoint		
Close Knit	C	Spectator	Nature Walk		
Diva	Atlas	Spot On	Sherman		
Dovetail	Axiom	Star Struck	Tryst		
Fast Forward	Baxter	Stepping Stones	Vatera		
Ferry	Cairo	Swing	Whip		
Gala II	Charm	Tight Rope			
Grande	Circa	Tilden			
Grandview	Classic Boucle	Tower Grid			
Helios					
Holbrook					

Check with your KnollTextiles representative for changes or additions.

Marco Maran
Gigi® Barstool and Swivel Chair

	description	seat h, min	seat h, max	arm h, min	arm h, max	w	d	h, min	h, max	weight
<p><i>Designer(s):</i> Marco Maran, 2002</p> 	87CS Gigi armless swivel chair 	17 1/4"	22 1/2"			22 9/10"	25"	33 1/2"	38 1/4"	17 lbs.
	87AS Gigi arm swivel chair 	17 1/4"	22 1/2"	24 1/4"	29 1/4"	22 9/10"	25"	33 1/2"	38 1/4"	21 lbs.
	87CM Gigi barstool, counter-height 		24"			19 3/4"	20"		40 1/2"	14 lbs.
	87CH Gigi barstool, bar-height 		29 1/2"			19 3/4"	20"		46"	15 lbs.

pattern no.	
87CS-()	\$1,260.
87AS-()	1,462.
87CM-()	892.
87CH-()	892.

Order Code





Example:	87AS-006
87AS	Gigi arm swivel chair
006	Mango shell

Specify:

1. Pattern number
2. Shell finish

Ordering Information

Shell Finishes:

-  Black (suffix 014)
-  Graphite (suffix 003)
- Mango (suffix 006)
-  Navy (suffix 012)
-  Red (suffix 007)
- Seafoam (suffix 010)
-  White (suffix 001)

 *KnollStudio 20-Day Program:*

Gigi arm and armless swivel chair and counter and bar-height barstools are available on the 20-day program, unupholstered, in white, graphite, black, red and navy shell finishes. For specific ordering information consult pages 27-28.

Maintenance:

See pages 28-29.

Note:

The Gigi Stool and Swivel Chair are Greenguard certified.

Construction

Description:

Coloured polypropylene and 15% fiberglass shell on a chrome-plated base. Arm chairs have black polypropylene molded arm pads. Chair back flexes for comfort. Gigi chairs are easily cleaned in food service areas.

Swivel:

Swivel mechanism with pneumatic seat height adjustment T-section polished aluminum base, with hard black casters. Colored polypropylene shell on a chrome-plated base. Armchairs have black polypropylene molded arm pads.

Ludwig Mies van der Rohe

Tubular Brno Chair

description	frame	seat					arm					textile fabric yds.	req. leather sq. ft.	weight
		h	h	w	d	h	h	w	d	h				
245A Brno Tugendhat arm chair - tubular frame, with thin seat and back	polished chrome	17 1/4"	25 1/4"	22 3/4"	22 1/2"	31 1/2"	1.7	28	23 lbs.					
	stainless steel	17 1/4"	25 1/4"	22 3/4"	22 1/2"	31 1/2"	1.7	28	24 lbs.					
245AT Brno Classic arm chair - tubular frame, with thick seat and back	polished chrome	17 1/4"	25 1/4"	22 3/4"	22 1/2"	31 1/2"	1.7	28	23 lbs.					
	stainless steel	17 1/4"	25 1/4"	22 3/4"	22 1/2"	31 1/2"	1.7	28	24 lbs.					

Designer(s):
Ludwig Mies van der Rohe, 1930
Design from the Mies van der Rohe Archive of The Museum of Modern Art

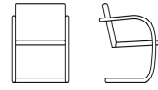

Award(s):
The Museum of Modern Art, New York, USA, 1977

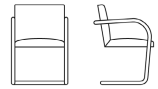

G Glides (add -G to end of pattern number)

P Perforated leather option (add P to end of pattern number and suffix -PERF to leather selection)

30

Order Code	Ordering Information	Construction
<i>Example:</i> 245A-S-P-VO906-PERF	<i>Finishes:</i> Polished Chrome (suffix C) Stainless Steel (suffix S)	<i>Frame:</i> Stainless steel: Tubular pre-stressed, pre-buffed 14 gauge stainless steel. Clean, seamless joints and hidden drilled or countersunk holes (as opposed to punched) render the chair free of deformation.
245A	Tubular arm chair, thin seat	Polished chrome: 11 gauge steel. The mirror chrome-plating process includes lengthy nickel and silicone coatings for rust protection and increased durability. All chairs are polished to a mirror finish. Clean, seamless joints and hidden drilled or countersunk holes (as opposed to punched) render the chair free of deformation.
S	Stainless Steel	Upholstery/COM information: Prices shown include fabric or leather upholstery. Contact your Knoll representative for colors. Only approved KnollTextiles and Spinneybeck leathers may be ordered.
P	Perforated leather	Maintenance: See pages 28-29.
VO906-PERF	Volo, Navy, perforated	Note: The KnollStudio logo and signature of Ludwig Mies van der Rohe are stamped into the frame of the chair under the arm.
		Optional glides: Six clear plastic glides in specially drilled holes.
		The Tubular Brno Chair is Greenguard certified.

Note:
The Tubular and Flat Bar Brno chairs are part of a collection. Please refer to Mies side chairs and lounge seating beginning on page 182 and tables, beginning on page 336.

- Specify:*
1. Pattern number
 2. Glide option
 3. Cal 133 Fire Code option
 4. Perforated leather option
 5. Textile selection

pattern no.	grades	COM	C	D	E	F	G	H	I	COL	V	W	X	Y
245A-C	\$2,314.	\$2,386.	\$2,454.	\$2,505.	\$2,551.	\$2,595.	\$2,641.	\$2,757.	\$2,964.	\$3,203.	\$3,436.	\$3,899.	\$4,012.	\$4,113.
245A-S	2,993.	3,065.	3,134.	3,184.	3,230.	3,273.	3,320.	3,436.	3,642.	3,882.	4,114.	4,579.	4,692.	4,790.
245AT-C	2,649.	2,719.	2,789.	2,842.	2,885.	2,929.	2,974.	3,091.	3,298.	3,536.	3,768.	4,235.	4,348.	4,446.
245AT-S	3,316.	3,384.	3,454.	3,507.	3,552.	3,595.	3,640.	3,755.	3,964.	4,203.	4,434.	4,900.	5,014.	5,113.
G	30.													
P	938.													

Approved KnollTextiles Grades/Fabrics						Spinneybeck Leather			
A Alignment † Beacon Bocce Cat's Cradle Chance Common Ground † Commuter Cloth † Crossroad Delite Dristi Foil Rap Heavy Metal Hourglass Mariner Monarch † Overture Prep † Presto † Soliloquy Sonnet Trophy Uni-Form	B continued Gala II Grande Grandview Helios Holbrook Journey Keaton Knoll Felt Knoll Hopsack Little Devil Ludlow Melody Mini Stitch † Paradigm Petal Pusher Pogo † Prairie Prim † Radiance Ransom Roam Rush Hour Spark † Spree Summit Sutton Synth Tabloid Tinge Venue Versa Vinyl Westwood Wide Angle † Yeni Zipline	C Atlas Axiom Baxter Cairo Charm Circa Classic Boucle Dahlia CR Decade Dune Durand Earthwork † Echo Empire Stripe Enmesh Entourage Essence Fable CR Fibra Greenwich Hudson Hula Hoop Kaleidoscope CR Kora CR Lagos Legend CR Lore CR Magnolia Metro Milestone Moto CR Noble Palisade Panache CR Pullman Quark Roundtrip Sahara Sequin CR Sinclair Smart Spectator Spot On	C continued Star Struck Stepping Stones Swing Tight Rope Tilden Tower Grid Treble CR Wit Zari CR D Compass CR Coterie Eclat Weave Hologram In The Loop Island Masquerade Menagerie Origins Woodland Zoom	F Atelier Biscayne Calais Cotton Velvet Cornaro Glider Icon Intrigue In Stitches Jasmine Liberty Mod Plaid Rivington Soon Topography Totem Tweed Frieze	G continued Straie Stripe Ultrasuede Utrillo H Arno Bavaria Catwalk Constance Firefly Magritte Stretch Appeal I Aswan Byron Cato Cummings Diamond Days Dynamic Ita Jaipur Knoll Velvet Limani Mepal North Island Olema Piper Rutledge Sandis Tudor Vermeer Zimba	U Vicenza † Volo † V Acqua † Andes † Embossed Tipped España † Hand Tipped Maremma Velluto Pelle † W Alaska † Amazon † Antique † Derby † Forte † Lucente Sabrina † Umbria	X Ducale † Ducale Velour † Y Cervo Copenhagen † Distressed Gemma Lucca Marissa † Portofino Riva † Saddle † Torello		
						† Approved for Cal 133 upholstery.			
						<i>Check with your KnollTextiles or Spinneybeck Representative for changes or additions.</i>			

Ludwig Mies van der Rohe

Flat Bar Brno Chair

	description	frame	seat h	arm h	w	d	h	textile fabric yds.	req. leather sq. ft.	weight
<i>Designer(s):</i> Ludwig Mies van der Rohe, 1930	255A Brno arm chair, flat bar frame, with arm pads	polished chrome	17 1/2"	25 3/4"	22 3/4"	22 1/2"	31 1/2"	1.7	28	37 lbs.
		stainless steel	17 1/2"	25 3/4"	22 3/4"	22 1/2"	31 1/2"	1.7	28	38 lbs.
<i>Award(s):</i> The Museum of Modern Art, New York, USA, 1977	255C Brno arm chair, flat bar frame, without arm pads	polished chrome	17 1/2"	25 3/4"	22 3/4"	22 1/2"	31 1/2"	1.7	28	37 lbs.
		stainless steel	17 1/2"	25 3/4"	22 3/4"	22 1/2"	31 1/2"	1.7	28	38 lbs.
	P Perforated leather option (add P to end of pattern number and suffix -PERF to leather selection)								30	
	G Glides (add -G to end of pattern number)									

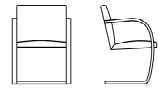
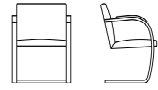

Order Code	Ordering Information	Construction
<i>Example:</i> 245A-S-P-VO906-PERF	<i>Finishes:</i> Polished Chrome (suffix C) Stainless Steel (suffix S)	<i>Perforated leather option:</i> The Tubular Brno Chairs are available in perforated leather upholstery. Specify suffix -P at end of pattern number and suffix -PERF at end of leather selection. 30 sq. ft. of leather required.
245A Tubular arm chair, thin seat	<i>Upholstery/COM information:</i> Prices shown include fabric or leather upholstery. Contact your Knoll representative for colors. Only approved KnollTextiles and Spinneybeck leathers may be ordered.	<i>Frame:</i> Stainless steel: Tubular pre-stressed, pre-buffed 14 gauge stainless steel. Clean, seamless joints and hidden drilled or countersunk holes (as opposed to punched) render the chair free of deformation.
S Stainless Steel	Customer's Own Material is available pending approval. For approval requirements, processing instructions and ordering information please see page 18.	<i>Polished chrome:</i> 11 gauge steel. The mirror chrome-plating process includes lengthy nickel and silicone coatings for rust protection and increased durability. All chairs are polished to a mirror finish. Clean, seamless joints and hidden drilled or countersunk holes (as opposed to punched) render the chair free of deformation.
P Perforated leather	<i>Woven leather option:</i> The Tubular Brno Chairs can be upholstered in woven leather as a COL. 30 sq. ft. of woven leather required. Specify suffix -W after pattern number.	<i>Upholstery:</i> Inner hardwood frame cushioned with variable density foam. Dymetrol seat suspension enhances comfort level. Replacement seat and backs are not available on Brno chairs. Tubular Brno with thin seat (245A, 245AS) has no welt detail. Tubular Brno with thick seat (245AT, 245AB) has welt detail on underside of seat.
VO906-PERF Volo, Navy, perforated	<i>Maintenance:</i> See pages 28-29.	<i>Optional glides:</i> Six clear plastic glides in specially drilled holes.
	<i>Note:</i> The KnollStudio logo and signature of Ludwig Mies van der Rohe are stamped into the frame of the chair under the arm.	
	The Tubular Brno Chair is Greenguard certified.	

Note:
The Tubular and Flat Bar Brno chairs are part of a collection. Please refer to Mies side chairs and lounge seating beginning on page 182 and tables, beginning on page 336.

- Specify:*
1. Pattern number
 2. Glide option
 3. Cal 133 Fire Code option
 4. Perforated leather option
 5. Textile selection

pattern no.	grades	COM	C	D	E	F	G	H	I	COL	V	W	X	Y
255A-C	\$3,298.	\$3,375.	\$3,447.	\$3,498.	\$3,544.	\$3,587.	\$3,636.	\$3,752.	\$3,967.	\$4,208.	\$4,441.	\$4,919.	\$5,034.	\$5,138.
255A-S	4,937.	5,013.	5,084.	5,139.	5,183.	5,227.	5,273.	5,390.	5,606.	5,848.	6,082.	6,559.	6,673.	6,775.
255C-C	2,974.	3,045.	3,114.	3,169.	3,217.	3,257.	3,301.	3,416.	3,630.	3,867.	4,097.	4,562.	4,676.	4,775.
255C-S	4,590.	4,662.	4,730.	4,784.	4,833.	4,874.	4,917.	5,032.	5,244.	5,483.	5,712.	6,179.	6,292.	6,389.
P	938.													
G	30.													

Approved KnollTextiles Grades/Fabrics				Spinneybeck Leather										
A Alignment † Beacon Bocce Cat's Cradle Chance Common Ground † Commuter Cloth † Crossroad Delite Hourglass Mariner Monarch † Overture Prep † Presto † Soliloquy Sonnet Trophy	B continued Gala II Grande Grandview Helios Holbrook Journey Keaton Knoll Felt Knoll Hopsack Little Devil Ludlow Melody Mini Stitch † Paradigm Petal Pusher Pogo † Prairie Prim † Radiance Ransom Roam Rush Hour Spark † Spree Summit Sutton Synth Tabloid Tinge Venue Versa Vinyl Westwood Wide Angle † Yeni Zipline	C Atlas Axiom Baxter Cairo Charm Circa Classic Boucle Dahlia CR Decade Dune Durand Earthwork † Echo Empire Stripe Enmesh Entourage Essence Fable CR Fibra Greenwich Hudson Hula Hoop Kaleidoscope CR Kora CR Lagos Legend CR Lore CR Magnolia Metro Milestone Moto CR Noble Palisade Panache CR Quark Roundtrip Sahara Sequin CR Sinclair Smart Spectator Spot On Star Struck	C continued Stepping Stones Swing Tight Rope Tilden Tower Grid Treble CR Wit Zari CR	D continued Compass CR Coterie Eclat Weave Hologram In The Loop Island Masquerade Menagerie Origins Woodland Zoom	E Aegean Cleo Demure Highland Ikat Stripe Juno Katazome Kimono Mamba Marquee Meroc Midpoint Nature Walk Sherman Shima Tryst Vatera Whip	F Atelier Biscayne Calais Cotton Velvet Cornaro Glider Icon Intrigue Jasmine Liberty Mod Plaid Rivington Soon Topography Totem Tweed Frieze	G continued Straie Stripe Ultrasuede Utrillo	H Arno Bavaria Constance Firefly Magritte	I Aswan Byron Cato Cummings Diamond Days Dynamic Ita Jaipur Knoll Velvet Limani Mepal North Island Olema Piper Rutledge Sandis Tudor Vermeer Zimba	U Vicenza † Volo †	V Acqua † Andes † Embossed Tipped España † Hand Tipped Maremma Velluto Pelle †	W Alaska † Amazon † Antique † Derby † Forte † Lucente Sabrina † Umbria	X Ducale † Ducale Velour †	Y Cervo Copenhagen † Distressed Gemma Lucca Marissa † Portofino Riva † Saddle † Torello

† Approved for Cal 133 upholstery.

Check with your KnollTextiles or Spinneybeck Representative for changes or additions.

Ludwig Mies van der Rohe

Four Seasons Stool

description	w	d	seat h	textile fabric yds.	req. leather sq. ft.	weight
257C Four Seasons Stool	17"	17"	30"	0.8	15	24 lbs.

Designer(s):
Ludwig Mies van der Rohe, 1958

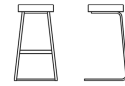





Order Code	Ordering Information	Construction
<i>Example:</i> 257C-DV116	<i>Upholstery/COM information:</i> Prices shown include fabric or leather upholstery. Contact your Knoll representative for colors. Only approved KnollTextiles and Spinneybeck leathers may be ordered.	<i>Frame:</i> Bent steel frame with chrome plating.
257C Four Seasons Stool	Customer's Own Material is available pending approval. For approval requirements, processing instructions and ordering information please see page 18.	<i>Upholstery:</i> Seat upholstered in leather or fabric over foam cushion reinforced with a plywood form.
DV116 Ducale Velour, Lava		
<i>Specify:</i> 1. Pattern number 2. Textile selection	<i>Maintenance:</i> See pages 28-29.	<i>Stitching:</i> Stitching detail is found on the rear left hand corner of the stool.
	<i>Note:</i> The KnollStudio logo and signature of Ludwig Mies van der Rohe are stamped into the base of the stool.	
	<i>Cal 133 Fire Code:</i> The Four Seasons Stools comply with the California Technical Bulletin 133 standard if upholstered in Cal 133 approved upholstery. Specify suffix -C at end of pattern number and suffix -133 at end of textile selection. Upcharge applies, see page 19.	
	The Four Season Stool is Greenguard certified.	

pattern no.	grades	COM								COL				
	A	B	C	D	E	F	G	H	I	U	V	W	X	Y
257C-()	\$3,520.	\$3,543.	\$3,566.	\$3,590.	\$3,609.	\$3,623.	\$3,647.	\$3,698.	\$3,729.	\$3,857.	\$3,945.	\$4,123.	\$4,162.	\$4,205.

Approved KnollTextiles Grades/Fabrics				Spinneybeck Leather			
A Alignment # Beacon Bocce Cat's Cradle Chance Common Ground # Commuter Cloth # Crossroad Delite Dristi Foil Rap Heavy Metal Hourglass Mariner Monarch # Overture Prep # Presto # Soliloquy Sonnet Trophy Uni-Form	B continued Dovetail # Fast Forward Ferry Forza Gala II Grande Grandview Helios Holbrook Journey Keaton Knoll Felt Knoll Hopsack Little Devil Ludlow Melody Mini Stitch # Paradigm Petal Pusher Pogo # Prairie Prim # Radiance Ransom Roam Rush Hour Spark # Spree Summit Sutton Synth Tabloid Tinge Venue Versa Vinyl Westwood Wide Angle # Yeni Zipline	C Atlas Axiom Baxter Cairo Charm Circa Classic Boucle Dahlia CR Decade Dune Durand Earthwork # Echo Empire Stripe Enmesh Entourage Essence Fable CR Fibra Greenwich Hudson Hula Hoop Kaleidoscope CR Kora CR Lagos Legend CR Lore CR Magnolia Metro Milestone Moto CR Noble Palisade Panache CR Pullman Quark Roundtrip Sahara Sequin CR Sinclair Smart Spectator Spot On Star Struck	C continued Stepping Stones Swing Tight Rope Tilden Tower Grid Treble CR Wit Zari CR D Compass CR Coterie Eclat Weave Hologram In The Loop Island Masquerade Menagerie Origins Woodland Zoom E Aegean Cleo Demure Highland Ikate Stripe Katazome Kimono Mamba Marquee Meroe Midpoint Nature Walk Sherman Shima Tryst Vatera Whip	F Atelier Biscayne Calais Cotton Velvet Cornaro Glider Icon Intrigue In Stitches Jasmine Liberty Mod Plaid Rivington Soon Topography Totem Tweed Frieze G Alter Ego Andissa Arber Gibson Haze Kamani Melange Modern Tweed Petite Floral Serendipity Spencer Straie Stripe Ultrasuede Utrillo	H Arno Bavaria Catwalk Constance Firefly Magritte Stretch Appeal I Aswan Byron Cato Cummings Diamond Days Dynamic Ita Jaipur Knoll Velvet Limani Mepal North Island Olema Piper Rutledge Sandis Tudor Vermeer Zimba	U Vicenza # Volo # V Acqua # Andes # Embossed Tipped # España # Hand Tipped # Velluto Pelle # W Alaska # Amazon # Antique # Derby # Forte # Lucente Sabrina # Umbria X Ducale Ducale Velour <i>Check with your KnollTextiles or Spinneybeck Representative for changes or additions.</i>	Y Cervo Copenhagen Distressed Gemma Lucca Marissa # Portofino Riva # Saddle #

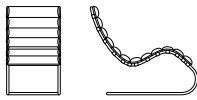
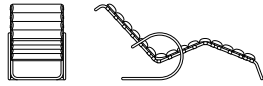
Ludwig Mies van der Rohe

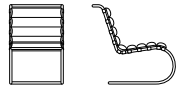
MR Lounge Seating

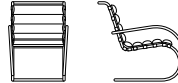
	description	frame	seat h	arm h	w	d	h	req. leather sq. ft.	weight
<i>Designer(s):</i> Mies van der Rohe, 1929 Design from the Mies van der Rohe Archive of The Museum of Modern Art	241LS MR chaise lounge 	Cowhide straps			23 1/2"	47 1/4"	37 1/2"	72	39 lbs.
		Sandwiched straps			23 1/2"	47 1/4"	37 1/2"	106	39 lbs.
<i>Award(s):</i> The Museum of Modern Art, New York, USA; Design Center Stuttgart Award, W. Germany, 1978	242LS MR adjustable chaise lounge 	Cowhide straps	19 1/2"		25 1/2"	70 1/4"	31 3/4"	91	43 lbs.
		Sandwiched straps	19 1/2"		25 1/2"	70 1/4"	31 3/4"	133	43 lbs.
	247LS MR armless lounge chair 	Cowhide straps	15 3/4"		23 1/2"	34 1/4"	33"	50	24 lbs.
		Sandwiched straps	15 3/4"		23 1/2"	34 1/4"	33"	75	24 lbs.
	248LS MR lounge chair with arms 	Cowhide straps	15 3/4"	23"	25 1/2"	36 1/4"	33"	50	32 lbs.
		Sandwiched straps	15 3/4"	23"	25 1/2"	36 1/4"	33"	75	32 lbs.

pattern no.	U	V	W	X	Y
241LS-(H01)	\$14,116.	\$14,709.	\$15,916.	\$16,168.	\$16,461.
241LS-(-)	15,334.	16,205.	17,980.	18,350.	18,782.
242LS-(H01)	17,280.	18,029.	19,557.	19,872.	20,239.
242LS-(-)	18,783.	19,876.	22,104.	22,568.	23,108.
247LS-(H01)	9,345.	9,759.	10,598.	10,768.	10,973.
247LS-(-)	10,240.	10,857.	12,113.	12,377.	12,680.
248LS-(H01)	10,905.	11,318.	12,151.	12,326.	12,531.
248LS-(-)	11,798.	12,414.	13,671.	13,935.	14,239.

Order Code	Ordering Information	Construction
<i>Example:</i> 241LS-H01-VP03	<i>Strap selection:</i> Cowhide belting frame supports to match the following colors: Black (suffix H01) For colors other than black, leather selected is sandwiched to belting thickness on cowhide backing. Select any approved Spinneybeck leather and color. <i>Upholstery note:</i> Prices shown include leather upholstery and strap selection. No Customer's Own Material can be used. <i>Note:</i> The MR Lounge Seating is Greenguard certified.	<i>Frame:</i> Seamless tubular stainless steel with a polished finish. Glides not included. <i>Upholstery straps:</i> Black cowhide belting straps with front, back, and sides all stained. For all other colors, upholstery is sandwiched to belting thickness on both front and back, with sides left natural. Cowhide backing. 241LS contains 12 belting support straps; 242LS contains 15 straps; 247LS and 248LS contain 9 straps each. <i>Upholstery:</i> Leather is crafted in a series of quilted and seamed cushion sections.
241LS Chaise lounge		
H01 Black cowhide straps		
VP03 Velluto Pelle, Espresso		
<i>Example:</i> 242LS-DE221-DE221		
242LS Chaise lounge		
DE221 Sandwiched Derby straps, Brick		
DE221 Derby, Brick		

Note:
The Mies lounge chairs are part of a collection. Please refer to Mies side chairs and lounge seating beginning on page 182, and tables, beginning on page 336.

Specify:



1. Pattern number
2. Strap selection
3. Textile selection

Spinneybeck Leather	
U Vicenza Volo	X Ducale Ducale Velours
V Acqua Andes Embossed Tipped España Hand Tipped Velluto Pelle	Y Capri Cervo Copenhagen Distressed Lucca Marissa Portofino Riva Saddle Torello
W Alaska Amazon Antique Derby Forte Lucente Sabrina	

Check with your Spinneybeck Representative for changes or additions.

Ludwig Mies van der Rohe

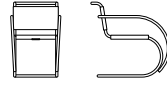
MR Chair

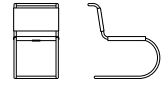
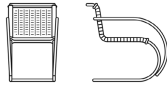
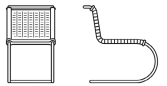
	description	seat h	arm h	w	d	h	weight
<i>Designer(s):</i> Ludwig Mies van der Rohe, 1927	256AS MR cowhide side chair with arms, stainless steel frame	18"	27"	21"	32 1/2"	31"	24 lbs.
<i>Award(s):</i> The Museum of Modern Art, New York, USA, 1977; Design Center Stuttgart Award, W.Germany, 1978							
	256CS MR cowhide armless side chair, stainless steel frame	18"		19 1/4"	27 1/4"	31"	17 lbs.
							
	256AC-RN MR Rattan side chair with arms, chrome frame	18"	27"	21"	32 1/2"	31"	24 lbs.
							
	256CC-RN MR Rattan armless side chair, chrome frame	18"		19 1/4"	27 1/4"	31"	17 lbs.
							
	256AKIT Replacement sling kit with laces for arm chair						
	256CKIT Replacement sling kit with laces for armless chair						
	256LACE Replacement leather laces for arm/armless chair						

pattern no.	
256AS-L()	\$3,857.
256CS-L()	2,460.
256AC-RN	3,253.
256CC-RN	2,444.
256AKIT-L()	1,180.
256CKIT-L()	1,180.
256LACE-L()	90.

Order Code	Ordering Information
------------	----------------------

<i>Example:</i> 256AS-L82	<i>Cowhide Selection:</i> Black(suffix L80) Light Brown (suffix L82) White Beige (suffix L84)	<i>Note:</i> The KnollStudio logo and signature of Ludwig Mies van der Rohe is stamped into the base of the MR chair.
256AS MR cowhide side chair with arms		
L82 Light Brown cowhide		

Note:
The MR chairs are part of a collection. Please refer to Mies side chairs and lounge seating beginning on page 182 and tables, beginning on page 336.

- Specify:*
1. Pattern number
 2. Cowhide selection

Upholstery/COM information:
Prices shown include leather upholstery.
No Customer's Own Material is available.

The MR Chair is Greenguard certified.

Maintenance:
See pages 28-29.

Construction

MR CHAIR
Frame:
Tubular stainless steel in polished finish with cowhide upholstery. Polished chrome frame with woven Rattan only.

Cowhide Upholstery:
Thick cowhide sling with leather laces.

Woven Rattan:
Natural cane handwoven onto polished chrome frame and protected by a clear lacquer finish.

Rattan Maintenance:
Use water and glycerin every three months to keep cane from drying out.



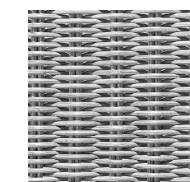

Glides:
Four molded clear plastic glides with twin-pin snap-in construction included with all MR chairs.

Replacement Cowhide Slings:
Slings can be replaced in the field by field services or a furniture repair specialist. Kit includes back and seat replacement slings with laces. Slings should be fitted by field services or by a professional reupholsterer.



Woven Rattan detail:

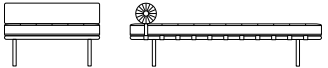

Ludwig Mies van der Rohe Barcelona® Lounge Seating

	description	frame	straps	seat h	bolster		d	h	req. leather sq. ft.	weight
<i>Designer(s):</i> Mies van der Rohe, 1929	250L Barcelona chair 	chrome		17"	29 1/2"	30"	30 1/4"	50	47 lbs.	
		stainless		17"	29 1/2"	30"	30 1/4"	50	53 lbs.	
<i>Award(s):</i> The Museum of Modern Art, New York, USA, 1977	251Y Barcelona stool 	chrome		14 1/4"	22 1/2"	24"	14 3/4"	25	28 lbs.	
		stainless		14 1/4"	22 1/2"	24"	14 3/4"	25	31 lbs.	
	251YC-L80 Barcelona stool with cowhide sling 	chrome		12 1/4"	21 1/2"	23"	12 1/4"	n/a	26 lbs.	
	250LC-S Child's Barcelona chair 	chrome		14"	24"	24"	25"	32	41 lbs.	
	251YC-S Child's Barcelona stool 	chrome		12"	19"	18"	12"	15	25 lbs.	
	258L Barcelona couch 	stainless	black	15.35"	25"	39"	78"	25"	110	84 lbs.
		stainless	colors	15.35"	25"	39"	78"	25"	110	84 lbs.



pattern no.	cowhide	U	V	W	X	Y
250LC 		\$8,810.	\$10,846.	\$11,542.	\$11,682.	\$11,851.
250LS		13,453.	13,916.	14,748.	14,894.	15,121.
251YC 		4,165.	5,118.	5,466.	5,537.	5,620.
251YS		7,785.	7,990.	8,405.	8,506.	8,596.
251YC-L80	2,855.					
250LC-S		7,477.	9,209.	9,798.	9,920.	10,064.
251YC-S		3,535.	4,346.	4,639.	4,703.	4,774.
258LS-(HO1)		15,393.	15,986.	17,189.	17,439.	17,731.
258LS-(-)		16,584.	17,445.	19,198.	19,560.	19,984.

Order Code

<i>Example:</i>	250LS-DV116
250LS	Barcelona chair
DV116	Ducale Velour, Lava

Note:
Barcelona lounge seating and couch are part of a collection. Please refer to Mies side chairs and lounge seating beginning on page 182 and tables, beginning on page 336.

Specify:

1. Pattern number
2. Cal 133 Fire Code option (chair and stool only)
3. Leather selection

Ordering Information

Upholstery note:
Prices shown include leather upholstery and strap selection. **No Customer's Own Material can be used.**

 KnollStudio 20-day Program:
The Barcelona chair and stool are available on the KnollStudio 20-day program with black volo leather and a chrome base. For specific information, consult pages 30-33.

Cal 133 Fire Code  :
The Barcelona Lounge Chair and Stool comply with the California Technical Bulletin 133 standard if upholstered in Cal 133 approved upholstery. Specify suffix -C after pattern number. Upcharge applies, see page 19.

Maintenance:
See pages 28-29.

Note:
The KnollStudio logo and signature of Ludwig Mies van der Rohe is stamped on each piece.

The Barcelona Lounge Seating Collection is Greenguard certified.

The Child's Barcelona chair and stool are compliant to the Consumer Product Safety Improvement Act of 2008 for Children's Products, 16 C.F.R. 1303, CPSIA Title 1 Section 101 for Total Lead in Substrates and Surface Coatings.

Construction

BARCELONA CHAIR AND STOOL
Stainless Steel Frame:
Premium grade 304 bar stock stainless steel. Single piece construction ensures long-term durability. Frame is shaped, welded and hand-buffed to mirror finish. Upholstery straps attached with solid stainless steel screws.

Chrome Frame:
Hand-ground and hand-buffed to a mirror finish. Upholstery attaches with aluminum rivets.

Upholstery straps:
Cowhide belting straps. Side and all sides are dyed to match specified upholstery color. Chair contains 17 belting support straps; stool 7. Child's Chair contains 13 belting support straps; stool 7.

Upholstery:
Chair has 40 individual panels for the chair and 16 for the stool; Child's Chair has 40 individual panels for the chair and 16 for the stool. Individual panels are cut, hand-welted, and hand-tufted with leather and buttons produced from a single cowhide. Cushions are premium quality, highly resilient urethane foam with down-like dacron polyester fiberfill.

Child's Barcelona Chair and Stool:
The Child's Barcelona Chair and Stool is 80% scale of standard size.

BARCELONA STOOL WITH COWHIDE SLING:
Thick cowhide sling in black with nylon laces on a chrome frame.

BARCELONA COUCH
Platform:
Hardwood frame is Sapele Mahogany from Africa. Wood has oak-like strength and is characterized by a dark or reddish-brown color. Frame is finished with a protective clear lacquer finish. 11 thick cowhide leather straps over rubber webbing.

Legs:
Tubular steel in polished stainless steel finish.







Bolster:
Bolster in matching leather is secured to cushion platform with straps complete with lock snaps.

Upholstery straps:
Cowhide belting straps with front, back, and side edges all stained to match specified upholstery color. For black straps, specify option (HO1). For matching straps in all other colors, specify leather upholstery selection and straps will be produced to match. Couch contains 11 belting support straps over rubber webbing.

Upholstery:
72 individual panels are cut, hand-welted and hand-tufted with leather and buttons produced from a single cowhide. Cushions are premium quality, fire retardant, high resilient urethane foam with down-like dacron polyester fiberfill.

Spinneybeck Leather

U Vicenza 
Volo 

V Acqua 
Andes 
Embossed Tipped *
España 
Hand Tipped  *
Maremma 
Velluto Pelle 

X Ducale 
Ducale Velours 

Y Cervo  *
Copenhagen 
Distressed 
Lucca 
Marissa 
Portofino  *
Riva 
Saddle 

 Approved for Cal 133 upholstery.
* Not approved for Cal133 upholstery on 258LS.

Check with your KnollTextiles or Spinneybeck Representative for changes or additions.

Ludwig Mies van der Rohe

Krefeld™ Collection

Designer(s):
Ludwig Mies van der Rohe, 1930
Design from the Mies van der Rohe Archive of The Museum of Modern Art



description	seat h	arm h	w	d	h	type	textile fabric yds.	req. leather sq. ft.	weight	
751 Lounge chair	17 1/4"	25"	32"	27"	30"		6.5	80	59 lbs.	
Lounge chair in textile with leather welt option							uphol.	6.5		
							welt		21	
752 Settee	17 1/4"	25"	57"	27"	30"		8	120	93 lbs.	
Settee in textile with leather welt option							uphol.	8		
							welt		25	

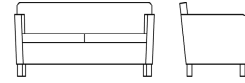
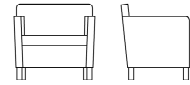

Order Code	Ordering Information	Construction
<i>Example:</i> 751-AWE-DV112	<i>Leg finishes:</i> Clear Oak (suffix AOC) Deep Red Mahogany (suffix AF) Light Walnut (suffix AWA) Medium Cherry (suffix AM) Wenge (suffix AWE)	<i>Frame:</i> Inner frame in engineered hardwood and plywood. Legs are removable, and are attached to metal plate attached to frame. Coil spring suspension for enhanced comfort. Dynamic suspension in the back for added flexibility and support. Legs are ash hardwood stained (in wenge, medium cherry, deep red mahogany, walnut and clear oak).
751 Krefeld lounge chair		<i>Inside dimensions:</i> 751 Lounge Chair: d: 21" w: 26" *
AWE Wenge legs		
DV112 Ducale Velour, Brandy		
<i>Example:</i> 752-AWA-K1026/3-VO904	<i>Leather Welt Option:</i> The Krefeld collection may be specified with an optional leather welt option. Welt contours all edges, including cushions. Please specify pattern number with LT suffix and add appropriate leather upcharge for total list price of the piece. Leather welt option is available on textile upholstery only.	752 Settee: d: 21" w: 51" *
752 Krefeld settee		753 Sofa: d: 21" w: 76" *
AWA Light Walnut legs		<i>*Width measured at the inside of the front of the arms. The chair tapers back, resulting in less width at the back of the chair than the front.</i>
K1026/3 Cross Stitch, Windsor		
VO904 Volo, Stallion welt		

Krefeld lounge seating is part of a collection. Please refer to Mies side chairs and lounge seating beginning on page 182 and tables, beginning on page 336.

Specify:

1. Pattern number
2. Leg finish
3. Textile selection

Leather Welt selection, specify:

1. Pattern number
2. Leg finish
3. Textile selection
4. Leather Welt Selection (upcharge applies)

Maintenance:
See pages 28-29.

Note:
The Krefeld Collection is Greenguard certified.

pattern no.	grades A	COM B	C	D	E	F	G	H	I	COL U	V	W	X	Y
751-(-)(-)	\$3,711.	\$4,010.	\$4,291.	\$4,604.	\$4,857.	\$5,044.	\$5,354.	\$5,952.	\$6,559.	\$7,379.	\$7,921.	\$9,039.	\$9,267.	\$9,538.

751LT-(-)(-)(-)	3,711.	4,010.	4,291.	4,604.	4,857.	5,044.	5,354.	5,952.	6,559.					
upchg, welt										1,042.	1,173.	1,437.	1,493.	1,557.
752-(-)(-)	5,843.	6,150.	6,448.	6,774.	7,038.	7,234.	7,561.	8,184.	8,641.	11,563.	12,282.	13,744.	14,047.	14,401.

752LT-(-)(-)(-)	5,843.	6,150.	6,448.	6,774.	7,038.	7,234.	7,561.	8,184.	8,641.					
upchg, welt										1,233.	1,387.	1,704.	1,770.	1,844.

Approved KnollTextiles Grades/Fabrics						Spinneybeck Leather			
A Alignment ‡ Beacon Bocce Cat's Cradle Chance Common Ground ‡ Commuter Cloth ‡ Crossroad Delite Hourglass Mariner Monarch ‡ Overture Prep ‡ Sonnet Trophy Uni-Form	B continued Grandview Helios Holbrook Journey Keaton Knoll Felt ‡ Knoll Hopsack ‡ Little Devil Ludlow Melody Paradigm Petal Pusher Prairie Prim ‡ Pogo Radiance Ransom Roam Rush Hour Spark ‡ Spree Summit Sutton ‡ Synth Tabloid Tinge Venue Versa Vinyl Wide Angle ‡ Zipline	C Atlas Axiom Cairo Charm Circa Classic Boucle Dahlia CR Decade Durand Earthwork ‡ Echo Empire Stripe Entourage Essence Fable CR Fibra Greenwich Hudson Hula Hoop Kora CR Lagos Lore CR Metro Milestone Moto CR Palisade Panache CR Pullman Quark Roundtrip	C continued Sequin CR Spot On Star Struck Stepping Stones Swing Tight Rope Tilden Tower Grid Wit Zari CR	D Coterie Eclat Weave Hologram Island Kabuki Masquerade Menagerie Origins Woodland Zoom	E Aegean Demure Highland Ikat Stripe Katazome Kimono Mamba Marquee Meroe Nature Walk Sherman Shima Tryst Whip	G Alter Ego Haze Melange Modern Tweed Petite Floral Ultrasuede ‡ H Arno Constance Firefly Magritte Stretch Appeal	I Aswan Byron Cato Diamond Days Dynamic Knoll Velvet Olema Piper Rutledge Sandis Tudor Vermeer Zimba	U Vicenza ‡ Volo ‡ V Acqua ‡ Andes ‡ Embossed Tipped España ‡ Hand Tipped ‡ Velluto Pelle ‡ W Alaska ‡ Amazon ‡ Antique ‡ Forte ‡ Lucente Sabrina ‡ Umbria ‡ ‡ Approved for Cal 133 upholstery.	Y Cervo Copenhagen ‡ Distressed ‡ Marissa ‡ Riva ‡ Saddle ‡

Check with your KnollTextiles or Spinneybeck Representative for changes or additions.

Ludwig Mies van der Rohe

Krefeld™ Collection

Designer(s):
Ludwig Mies van der Rohe, 1930
Design from the Mies van der Rohe Archive of The Museum of Modern Art



description	seat h	arm h	w	d	h	type	textile fabric yds.	req. leather sq. ft.	weight	
753 Sofa	17 1/4"	25"	82"	27"	30"		11	160	122 lbs.	
Sofa in textile with leather welt option							uphol.	11		
							welt		34	
754 Ottoman	17 1/4"		26"	20 1/2"	17 1/4"		3	50	17 lbs.	
Ottoman in textile with leather welt option							uphol.	3		
							welt		15	

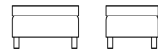
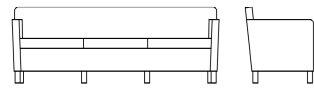

pattern no.	grades A	COM B	C	D	E	F	G	H	I	COL U	V	W	X	Y
753-(-)(-)	\$7,610.	\$7,965.	\$8,304.	\$8,680.	\$8,989.	\$9,209.	\$9,584.	\$10,298.	\$10,824.	\$14,712.	\$15,583.	\$17,366.	\$17,736.	\$18,168.

753LT-(-)(-)(-)	7,610.	7,965.	8,304.	8,680.	8,989.	9,209.	9,584.	10,298.	10,824.					
upchg, welt										1,675.	1,888.	2,315.	2,403.	2,507.
754-(-)(-)	2,176.	2,266.	2,354.	2,449.	2,528.	2,583.	2,680.	2,862.	2,996.	4,007.	4,212.	4,633.	4,722.	4,822.

754LT-(-)(-)(-)	2,176.	2,266.	2,354.	2,449.	2,528.	2,583.	2,680.	2,862.	2,996.					
upchg, welt										739.	833.	1,022.	1,062.	1,107.

Order Code	Ordering Information	Construction
<i>Example:</i> 751-AWE-DV112	<i>Leg finishes:</i> Clear Oak (suffix AOC) Deep Red Mahogany (suffix AF) Light Walnut (suffix AWA) Medium Cherry (suffix AM) Wenge (suffix AWE)	<i>Frame:</i> Inner frame in engineered hardwood and plywood. Legs are removable, and are attached to metal plate attached to frame. Coil spring suspension for enhanced comfort. Dynamic suspension in the back for added flexibility and support. Legs are ash hardwood stained (in wenge, medium cherry, deep red mahogany, walnut and clear oak).
751 Krefeld lounge chair		<i>Inside dimensions:</i> 751 Lounge Chair: d: 21" w: 26" *
AWE Wenge legs		752 Settee: d: 21" w: 51" *
DV112 Ducale Velour, Brandy		753 Sofa: d: 21" w: 76" *
<i>Example:</i> 752-AWA-K1026/3-VO904	<i>Leather Welt Option:</i> The Krefeld collection may be specified with an optional leather welt option. Welt contours all edges, including cushions. Please specify pattern number with LT suffix and add appropriate leather upcharge for total list price of the piece. Leather welt option is available on textile upholstery only.	<i>Upholstery:</i> High-density foam cushions with dacron top layer. Benches and ottoman feature dual density foam for added softness and support. Side panel upholstery is tailored to fit, seat and back cushions are more loose.
752 Krefeld settee		<i>*Width measured at the inside of the front of the arms. The chair tapers back, resulting in less width at the back of the chair than the front.</i>
AWA Light Walnut legs		
K1026/3 Cross Stitch, Windsor		
VO904 Volo, Stallion welt	<i>Cal 133 Fire Code:</i> The Krefeld Lounge Collection complies with the California Technical Bulletin 133 standard if upholstered in Cal 133 approved upholstery. Specify suffix -C after pattern number. Upcharge applies, see page 19.	
	<i>Maintenance:</i> See pages 28-29.	
	<i>Note:</i> The Krefeld Collection is Greenguard certified.	

Krefeld lounge seating is part of a collection. Please refer to Mies side chairs and lounge seating beginning on page 182 and tables, beginning on page 336.

Specify:

1. Pattern number
2. Leg finish
3. Textile selection

Leather Welt selection, specify:

1. Pattern number
2. Leg finish
3. Textile selection
4. Leather Welt Selection (upcharge applies)

Approved KnollTextiles Grades/Fabrics						Spinneybeck Leather			
A Alignment # Beacon Bocce Cat's Cradle Chance Common Ground # Commuter Cloth # Crossroad Delite Hourglass Mariner Monarch # Overture Prep # Sonnet Trophy Uni-Form	B continued Grandview Helios Holbrook Journey Keaton Knoll Felt # Knoll Hopsack # Little Devil Ludlow Melody Paradigm Petal Pusher Prairie Prim # Pogo Radiance Ransom Roam Rush Hour Spark # Spree Summit Sutton # Synth Tabloid Tinge Venue Versa Vinyl Wide Angle # Zipline	C Atlas Axiom Cairo Charm Circa Classic Boucle Dahlia CR Decade Durand Earthwork # Echo Empire Stripe Entourage Essence Fable CR Fibra Greenwich Hudson Hula Hoop Kora CR Lagos Lore CR Metro Milestone Moto CR Palisade Panache CR Pullman Quark Roundtrip	C continued Sequin CR Spot On Star Struck Stepping Stones Swing Tight Rope Tilden Tower Grid Wit Zari CR	D Coterie Eclat Weave Hologram Island Kabuki Masquerade Menagerie Origins Woodland Zoom	E Aegean Demure Highland Ikat Stripe Katazome Kimono Mamba Marquee Meroe Nature Walk Sherman Shima Tryst Whip	G Alter Ego Haze Melange Modern Tweed Petite Floral Ultrasuede # H Arno Constance Firefly Magritte Stretch Appeal	I Aswan Byron Cato Diamond Days Dynamic Knoll Velvet Olema Piper Rutledge Sandis Tudor Vermeer Zimba	U Vicenza # Volo # V Acqua # Andes # Embossed Tipped España # Hand Tipped # Velluto Pelle # W Alaska # Amazon # Antique # Forte # Lucente Sabrina # Umbria # Approved for Cal 133 upholstery.	Y Cervo Copenhagen # Distressed # Marissa # Riva # Saddle #



Check with your KnollTextiles or Spinneybeck Representative for changes or additions.

Ludwig Mies van der Rohe

Krefeld™ Collection

Designer(s):
Ludwig Mies van der Rohe, 1930
Design from the Mies van der Rohe Archive of The Museum of Modern Art

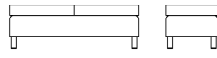

description	seat h	arm h	w	d	h	type	textile fabric yds.	req. leather sq. ft.	weight
755 Medium Bench 	17 1/4"		51"	20 1/2"	17 1/4"		5	64	21 lbs.
Medium Bench in textile with leather welt option						uphol.	5		
						welt		20	
756 Large Bench 	17 1/4"		76"	20 1/2"	17 1/4"		5.5	80	45 lbs.
Large Bench in textile with leather welt option						uphol.	5.5		
						welt		20	

pattern no.	grades A	COM B	C	D	E	F	G	H	I	COL U	V	W	X	Y
755-(-)(-)	\$3,018.	\$3,175.	\$3,330.	\$3,500.	\$3,637.	\$3,738.	\$3,904.	\$4,228.	\$4,464.	\$4,789.	\$5,194.	\$6,021.	\$6,191.	\$6,390.

755LT-(-)(-)(-)	3,018.	3,175.	3,330.	3,500.	3,637.	3,738.	3,904.	4,228.	4,464.					
upchg, welt										988.	1,114.	1,376.	1,431.	1,494.
756-(-)(-)	3,502.	3,715.	3,923.	4,145.	4,332.	4,464.	4,687.	5,118.	5,435.	6,242.	6,813.	7,970.	8,209.	8,491.

756LT-(-)(-)(-)	3,502.	3,715.	3,923.	4,145.	4,332.	4,464.	4,687.	5,118.	5,435.					
upchg, welt										1,019.	1,145.	1,406.	1,462.	1,526.

Order Code	Ordering Information	Construction
<i>Example:</i> 751-AWE-DV112	<i>Leg finishes:</i> Clear Oak (suffix AOC) Deep Red Mahogany (suffix AF) Light Walnut (suffix AWA) Medium Cherry (suffix AM) Wenge (suffix AWE)	<i>Frame:</i> Inner frame in engineered hardwood and plywood. Legs are removable, and are attached to metal plate attached to frame. <i>Inside dimensions:</i> 751 Lounge Chair: d: 21" w: 26" * 752 Settee: d: 21" w: 51" * 753 Sofa: d: 21" w: 76" *
751 Krefeld lounge chair		
AWE Wenge legs		
DV112 Ducale Velour, Brandy		
<i>Example:</i> 752-AWA-K1026/3-VO904	<i>Leather Welt Option:</i> The Krefeld collection may be specified with an optional leather welt option. Welt contours all edges, including cushions. Please specify pattern number with LT suffix and add appropriate leather upcharge for total list price of the piece. Leather welt option is available on textile upholstery only.	<i>Upholstery:</i> High-density foam cushions with dacron top layer. Benches and ottoman feature dual density foam for added softness and support. Side panel upholstery is tailored to fit, seat and back cushions are more loose.
752 Krefeld settee		
AWA Light Walnut legs		
K1026/3 Cross Stitch, Windsor		
VO904 Volo, Stallion welt		

Krefeld lounge seating is part of a collection. Please refer to Mies side chairs and lounge seating beginning on page 182 and tables, beginning on page 336.

Specify:

1. Pattern number
2. Leg finish
3. Textile selection

Leather Welt selection, specify:

1. Pattern number
2. Leg finish
3. Textile selection
4. Leather Welt Selection (upcharge applies)

Cal 133 Fire Code:
The Krefeld Lounge Collection complies with the California Technical Bulletin 133 standard if upholstered in Cal 133 approved upholstery. Specify suffix -C after pattern number. Upcharge applies, see page 19.

Maintenance:
See pages 28-29.

Note:
The Krefeld Collection is Greenguard certified.

Approved KnollTextiles Grades/Fabrics						Spinneybeck Leather				
A Alignment # Beacon Bocce Cat's Cradle Chance Common Ground # Commuter Cloth # Crossroad Delite Hourglass Mariner Monarch # Overture Prep # Sonnet Trophy Uni-Form	B continued Grandview Helios Holbrook Journey Keaton Knoll Felt # Knoll Hopsack # Little Devil Ludlow Melody Paradigm Petal Pusher Prairie Prim # Pogo Radiance Ransom Roam Rush Hour Spark # Spree Summit Sutton # Synth Tabloid Tinge Venue Versa Vinyl Wide Angle # Zipline	C Atlas Axiom Cairo Charm Circa Classic Boucle Dahlia CR Decade Durand Earthwork # Echo Empire Stripe Entourage Essence Fable CR Fibra Greenwich Hudson Hula Hoop Kora CR Lagos Lore CR Metro Milestone Moto CR Palisade Panache CR Pullman Quark Roundtrip	C continued Sequin CR Spot On Star Struck Stepping Stones Swing Tight Rope Tilden Tower Grid Wit Zari CR	D Coterie Eclat Weave Hologram Island Kabuki Masquerade Menagerie Origins Woodland Zoom	E Aegean Demure Highland Ikat Stripe Katazome Kimono Mamba Marquee Meroe Nature Walk Sherman Shima Tryst Whip	F Atelier Biscayne Calais Cotton Velvet Cornaro Glider Icon Intrigue In Stitches Liberty Mod Plaid Rivington Soon Topography Totem	G Alter Ego Haze Melange Modern Tweed Petite Floral Ultrasuede # H Arno Constance Firefly Magritte Stretch Appeal	I Aswan Byron Cato Diamond Days Dynamic Knoll Velvet Olema Piper Rutledge Sandis Tudor Vermeer Zimba	U Vicenza # Volo # V Acqua # Andes # Embossed Tipped España # Hand Tipped # Velluto Pelle # W Alaska # Amazon # Antique # Forte # Lucente Sabrina # Umbria # Approved for Cal 133 upholstery.	Y Cervo Copenhagen # Distressed # Marissa # Riva # Saddle #

Check with your KnollTextiles or Spinneybeck Representative for changes or additions.

George Nakashima
Straight Chair

	description	seat h	w	d	h	weight
<i>Designer(s):</i> George Nakashima, 1946	N19 Straight Chair	17 1/4"	22 1/2"	17 1/2"	30"	11 lbs.



pattern no.	
N19-AW	\$1,236.

Order Code	Ordering Information	Construction
<i>Example:</i> N19-AW	<i>Finishes:</i> American Walnut (suffix AW)	<i>Frame:</i> Constructed from solid American Walnut, turned American Walnut legs and stretchers, and contrasting Hickory spindles, clear low-sheen finish and nylon glides.
N19 Straight Chair	<i>Maintenance:</i> See pages 28-29.	<i>Note:</i> American Walnut exhibits a high degree of natural color characteristics, ranging from chocolate, grey and purplish-browns to deep honey. Color variation will soften and become more uniform over time.
AW American Walnut	<i>Note:</i> The Straight Chair is Greenguard certified.	
<i>Note:</i> The Straight chair is part of a collection. Please refer to the Splay-Leg table on page 346.	Each chair features George Nakashima's signature under the seat.	
<i>Specify:</i> 1. Pattern number 2. Finish		

Jonathan Olivares

Aluminum Stacking Chair

	description	seat h	w	d	h	weight
<i>Designer(s):</i> Jonathan Olivares, 2012	OAC1 Olivares Chair	17 1/2"	22 1/3"	21 7/8"	31 1/2"	15 lbs.





pattern no.	list
OAC1-()	\$960.

Order Code	Ordering Information	Construction
<i>Example:</i> OAC1-WHT	<i>Paint finishes:</i>	<i>Shell:</i>
OAC1 Olivares chair	White (suffix WHT)	Constructed from die-cast aluminum with integrated leg tenons. A long low-profile nylon stacking bumper distributes the chair's weight over a wide area providing a more stable stacking condition. The designer's signature and KnollStudio logo are located under the seat.
WHT White paint finish	Grey (suffix GRY)	
	Yellow (suffix YEL)	
	Lime Green (suffix LGR)	
	Orange (suffix ORG)	
	Plum (suffix PLM)	
	Sky Blue (suffix SBL)	
	Blue (suffix BLU)	
	Dark Charcoal (CHR)	
<i>Specify:</i>	<i>Maintenance:</i>	<i>Legs:</i>
1. Pattern number	See pages 28-29.	Aluminum extruded legs are secured to the chair's shell using epoxy and stainless steel fasteners.
2. Paint finish selection		
		<i>Paint:</i>
		Ultra-durable polyester powder coat paint.
		<i>Glides:</i>
		1/4" flat nylon glides.
		<i>Stacking:</i>
		Chairs stack six on the floor.
		<i>Outdoor use:</i>
		With proper preventative maintenance, the Olivares chair is appropriate for outdoor environments.

Jorge Pensi

Toledo Stacking Chair

	description	seat h	arm h	w	d	h	textile fabric yds.	req. leather sq. ft.	weight
<i>Designer(s):</i> Jorge Pensi, 1988	29C Toledo Chair 	17 1/4"	27 1/4"	21 1/8"	21 1/4"	29 7/8"			15 lbs.
<i>Award(s):</i> First Place, Sidi Selection, Valencia, Spain, 1988; "Delta Plate" of ADI FAD, 1988; Design Center Stuttgart Award, W. Germany, 1990	29K Toledo Chair, seat cushion replacement 						0.6	7	



Order Code	Ordering Information	Construction
<i>Example:</i> 29C-29K-K161/1	<i>Note:</i> The Toledo Chair is available in the United States only.	<i>Cal 133 Fire Code #:</i> The Toledo Chair without seat pad complies with California Technical Bulletin 133. See page 18.
29C Toledo chair	 <i>KnollStudio 20-Day Program:</i> The Toledo Chair is available on the KnollStudio 20-Day program. For specific information, consult pages 30 - 33.	<i>Legs:</i> Anodized, polished tubular aluminum. The Toledo chair is 100% recyclable.
29K Seat cushion option	<i>Upholstery/COM information:</i> Prices shown include fabric or leather upholstery. Contact your Knoll representative for colors. Only approved KnollTextiles and Spinneybeck leathers may be ordered.	<i>Stacking feature:</i> Chairs can be stacked up to 4 high for compact storage.
K161/1 Classic Boucle, Pearl	<i>Note:</i> Toledo Chairs are stamped under the seat with the name of the designer and the manufacturer, AMAT 3.	<i>Outdoor use:</i> With proper preventative maintenance, the Toledo Chair is appropriate for outdoor environments. Aluminum will not reflect extreme outdoor temperatures.
<i>Note:</i> Toledo Chairs are part of a collection. Please refer to Pensi Tables on pages 350.	Customer's Own Material is available pending approval. For approval requirements, processing instructions and ordering information please see page 18.	<i>Optional seat pad:</i> Regardless of the textile, the seat pad is not approved for outdoor use.
<i>Specify:</i> 1. Pattern number 2. Seat pad option 3. Textile selection		Toledo Stacking Chair is manufactured in Spain by Amat-3.

pattern no.	grades	COM	C	D	E	F	G	H	I	COL	U	V	W	X	Y
29C 		\$2,012.													
29K	285.	311.	331.	358.	378.	392.	418.	468.	505.	499.	557.	669.	692.	720.	

Approved KnollTextiles Grades/Fabric						Spinneybeck Leathers					
A Alignment Analogy Beacon Bocce Cat's Cradle Chance Common Ground Commuter Cloth Dristi Foil Rap Heavy Metal Hourglass Mariner Metaphor Monarch Prep Presto Soliloquy Sonnet Stacks Trophy	B continued Close Knit Digit Digital Tape Dovetail Fast Forward Ferry Forza Framework Gala II Grande Grandview Journey Keaton Knoll Felt Knoll Hopsack Lyric Mini Stitch Night Life Nonchalant CR Paradigm Pogo Pop Prairie Prim Ransom Ricochet Roam Rush Hour Soiree Spark Spinoff Nuance Spotlight Spree Starry Night Sutton Synth Venue Versa Vinyl Wide Angle Zephyr Zipline	C Atlas Autobahn Axiom Baxter Biota Charm Circa Classic Boucle Dahlia CR Decade Durand Earthwork Echo Empire Stripe Knoll Hopsack Entourage Fable CR Fibra Fox Trot CR Greenwich Highline CR Hudson Hula Hoop Kaleidoscope CR Kora CR Legend CR Lore CR Metro Milestone Moto CR Noble Panache CR Pony Up Posh Quark Regard CR Roundtrip Sequin CR	C continued Sahara Sandpiper Sinclair Smart Spectator Spot On Star Struck Stepping Stones Swing Tight Rope Tilden Tower Grid Transition Treble CR Vibe Zari CR	F Atelier Biscayne Calais Cotton Velvet Cornaro Eclipse Glider Icon Intrigue Jubilee Kinship Mod Plaid Rivington Topography Totem Tweed Frieze	H Arno Bavaria Constance Gezelle Haiku Magritte	I Byron Canaan Cato Cummings Diamond Days Dynamic Fiori Galloway Gates Gramercy Jaipur Knoll Velvet Mepal North Island Olema Piper Ravello Rutledge Sandis Stirling Tudor Vermeer Walker Worth Zimba	U Vicenza Volo	V Acqua Andes Embossed Tipped España Hand Tipped Maremma Velluto Pelle	W Alaska Amazon Antique Arizona Derby Forte Lucente Sabrina Umbria	X Ducale Ducale Velour	Y Cervo Copenhagen Cordovan Distressed Gemma Lucca Marissa Portofino Prima Riva Torello

Check with your KnollTextiles or Spinneybeck Representative for changes or additions.

Charles Pfister

Petite Lounge Seating

Designer(s):
Charles Pfister, 1971

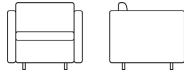
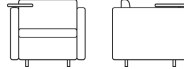

description	seat h	arm h	w	d	h	textile fabric yds.	req. leather sq. ft.	weight
1051C-S Petite lounge chair	16"	24"	29 1/2"	29 1/2"	26"	6.5	117	39 lbs.
								
1051C-ST-() Petite Pfister lounge chair with optional tablet arm	16"	24"	29 1/2"	29 1/2"	26"	6.5	117	41 lbs.
								

pattern no.	upcharge	grades	COM	C	D	E	F	G	H	I	COL	U	V	W	X	Y
1051C-S		\$2,855.	\$3,123.	\$3,380.	\$3,661.	\$3,891.	\$4,054.	\$4,333.	\$4,870.	\$5,418.	\$6,818.	\$7,779.	\$9,819.	\$10,137.	\$10,607.	
1051C-ST-()		3,606.	3,872.	4,132.	4,409.	4,639.	4,806.	5,082.	5,621.	6,170.	7,570.	8,529.	10,570.	10,886.	11,359.	

Order Code	Ordering Information	Construction
<i>Example:</i> 1051C-ST-R-H-K109/15	<i>Tablet arm option (suffix ST), lounge chair only:</i> Left handed (suffix L) Right handed (suffix R)	<i>Frame:</i> Constructed in sections with a combination plywood/hardwood seat and back.
1051C Petite Pfister lounge chair		
ST Tablet arm option		
R Right handed tablet arm		
H Caster option	<i>Caster option (suffix H), lounge chair only:</i> To specify four casters add -H to end of pattern number before upholstery selection.	<i>Upholstery:</i> Petite Pfister lounge seat and back cushion are fully upholstered. Double-needled top stitching on leather upholstery and on thin solid textiles. Single-needled top stitching on heavily ribbed fabrics and multicolor prints. No sag spring deck covered in black cotton textile.
K109/15 Haze, Persimmon	<i>Upholstery/COM information:</i> Prices shown include fabric or leather upholstery. Contact your Knoll representative for colors. Only approved KnollTextiles and Spinneybeck leathers may be ordered.	<i>Swivel tablet:</i> Machined aluminum, post and socket mechanism with black phenolic rectangular tablet; swivels 360°. Tablet dimensions are 10" x 14".
	Customer's Own Material is available pending approval. Non-railroad COM fabrics will require additional yardage. For approval requirements, processing instructions and ordering information please see page 18.	<i>Seat height:</i> Seat height is measured from the floor to the crown of the seat cushion. Height could vary up to 1/2" depending on leather or textile specified.
	<i>Cal 133 Fire Code:</i> Petite Pfister lounge seating complies with the California Technical Bulletin 133 standard if upholstered in Cal 133 approved upholstery. Specify suffix -C at end of pattern number and suffix -133 at end of textile selection. Upcharge applies, see page 19.	
	<i>Note:</i> The Petite Pfister Lounge Seating Collection is Greenguard certified.	

- Specify:
1. Pattern number
 2. Cal 133 Fire Code option
 3. Tablet option (lounge chair only), right or left
 4. Caster option (lounge chair only)
 5. Textile selection

Approved KnollTextiles Grades/Fabrics				Spinneybeck Leather										
A Alignment † Beacon Bocce Cat's Cradle Chance Common Ground † Commuter Cloth † Crossroad Delite Dristi Hourglass Mariner Monarch Overture Prep Soliloquy Sonnet Trophy Uni-Form	B continued Grandview Helios Holbrook Journey Keaton Knoll Felt † Knoll Hopsack † Little Devil Ludlow Melody Mini Stitch Paradigm Petal Pusher Pogo † Prairie Prim † Radiance Ransom Roam Rush Hour Spark † Spree Summit Sutton Synth Tabloid Tinge Venue Versa Vinyl Westwood Wide Angle † Yeni Zipline	C Atlas Axiom Baxter Cairo Charm Circa Classic Boucle Dahlia CR Decade Dune Durand Earthwork † Echo Empire Stripe Entourage Esseence Fable CR Fibra Greenwich Hudson Hula Hoop Kaleidoscope CR Kora CR Lagos Legend CR Lore CR Magnolia Metro Milestone Moto CR Noble Palisade Panache CR Pullman Quark Roundtrip Sahara Sequin CR Sinclair Smart Spectator	C continued Spot On Star Struck Stepping Stones Swing Tight Rope Tilden Tower Grid Treble CR Wit Zari CR	D Compass CR Coterie Eclat Weave Hologram Island Masquerade Menagerie Origins Woodland Zoom	E Aegean Cleo Demure Highland Ikati Stripe Juno Katazome Kimono Mamba Marquee Meroe Midpoint Nature Walk Sherman Shima Tryst Vatera Whip	F Atelier Biscayne Calais Cotton Velvet Cornaro Glider Icon Intrigue In Stitches Jasmine Liberty Mod Plaid Rivington Soon Topography Totem	G Alter Ego Andissa Arber Gibson Haze Kamani Melange Modern Tweed Petite Floral Serendipity Spencer † Straie Stripe Ultrasuede Utrillo	H Arno Bavaria Catwalk Constance Firefly Magritte Stretch Appeal	I Aswan Byron Cato Cummings Diamond Days Dynamic Ita Jaipur Knoll Velvet † Mepal North Island Olema Piper Rutledge Sandis Tudor Vermeer Zimba	U Vicenza † Volo †	V Acqua † Andes † Embossed Tipped España † Hand Tipped Maremma Velluto Pelle †	W Alaska † Amazon † Antique † Derby † Forte † Lucente † Sabrina † Umbria	X Ducale † Ducale Velour †	Y Cervo Copenhagen † Lucca Marissa † Portofino Riva † Saddle † Torello



† Approved for Cal 133 upholstery.
Check with your KnollTextiles or Spinneybeck Representative for changes or additions.

Charles Pfister

Petite Lounge Seating

Designer(s):
Charles Pfister, 1971

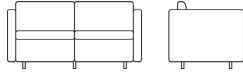

description	height, seat	height, arm	width	depth	height	textile fabric yards	leather sq ft	weight
1052C-S Petite settee 	16"	24"	53"	29 1/2"	26"	10.8	194	64 lbs.
1053C-S Petite sofa 	16"	24"	76 1/2"	29 1/2"	26"	15.0	270	88 lbs.
1059C-S Petite ottoman 			22"	22"	16"	3.8	69	18 lbs.
H Optional casters for Petite lounge chair								

pattern no.	upcharge	grade A	COM B	C	D	E	F	G	H	I	COL U	V	W	X	Y
1052C-S		\$5,014.	\$5,455.	\$5,880.	\$6,339.	\$6,719.	\$6,994.	\$7,459.	\$8,343.	\$9,248.	\$11,615.	\$13,206.	\$16,589.	\$17,115.	\$17,897.
1053C-S		7,008.	7,625.	8,212.	8,860.	9,389.	9,773.	10,420.	11,652.	12,918.	16,249.	18,459.	23,166.	23,898.	24,988.
1059C-S		2,108.	2,257.	2,394.	2,546.	2,669.	2,758.	2,912.	3,197.	3,492.	4,453.	4,986.	6,116.	6,294.	6,557.
H	n/c														

Order Code	Ordering Information	Construction
<i>Example:</i> 1051C-ST-R-H-K109/15	<i>Tablet arm option (suffix ST), lounge chair only:</i>	<i>Frame:</i>
1051C Petite Pfister lounge chair	Left handed (suffix L)	Constructed in sections with a combination plywood/hardwood seat and back.
ST Tablet arm option	Right handed (suffix R)	
R Right handed tablet arm		<i>Upholstery:</i>
H Caster option	<i>Caster option (suffix H), lounge chair only:</i>	Petite Pfister lounge seat and back cushion are fully upholstered. Double-needled top stitching on leather upholstery and on thin solid textiles. Single-needled top stitching on heavily ribbed fabrics and multicolor prints. No sag spring deck covered in black cotton textile.
K109/15 Haze, Persimmon	To specify four casters add -H to end of pattern number before upholstery selection.	<i>Swivel tablet:</i>
	<i>Upholstery/COM information:</i>	Machined aluminum, post and socket mechanism with black phenolic rectangular tablet; swivels 360°. Tablet dimensions are 10" x 14".
	Prices shown include fabric or leather upholstery. Contact your Knoll representative for colors. Only approved KnollTextiles and Spinneybeck leathers may be ordered.	<i>Seat height:</i>
	Customer's Own Material is available pending approval. Non-railroad COM fabrics will require additional yardage. For approval requirements, processing instructions and ordering information please see page 18.	Seat height is measured from the floor to the crown of the seat cushion. Height could vary up to 1/2" depending on leather or textile specified.
	<i>Cal 133 Fire Code:</i>	
	Petite Pfister lounge seating complies with the California Technical Bulletin 133 standard if upholstered in Cal 133 approved upholstery. Specify suffix -C at end of pattern number and suffix -133 at end of textile selection. Upcharge applies, see page 19.	
	<i>Note:</i>	
	The Petite Pfister Lounge Seating Collection is Greenguard certified.	

Approved KnollTextiles Grades/Fabrics								Spinneybeck Leather					
A Alignment ‡ Beacon Bocce Cat's Cradle Chance Common Ground ‡ Commuter Cloth ‡ Crossroad Delite Dristi Hourglass Mariner Monarch Overture Prep Soliloquy Sonnet Trophy Uni-Form	B continued Grande Grandview Helios Hollbrook Journey Keaton Knoll Felt ‡ Knoll Hopsack ‡ Little Devil Ludlow Melody Mini Stitch Paradigm Petal Pusher Pogo ‡ Prairie Prim ‡ Radiance Ransom Roam Rush Hour Spark ‡ Spree Summit Sutton Synth Tabloid Tinge Venue Versa Vinyl Westwood Wide Angle ‡ Yeni Zipline	C Atlas Axiom Baxter Cairo Charm Circa Classic Boucle Dahlia CR Decade Dune Durand Earthwork ‡ Echo Empire Stripe Entourage Essence Fable CR Fibra Greenwich Hudson Hula Hoop Kaleidoscope CR Kora CR Lagos Legend CR Lore CR Magnolia Metro Milestone Moto CR Noble Palisade Panache CR Pullman Quark Roundtrip Sahara Sequin CR Sinclair Smart Spectator	C continued Spot On Star Struck Stepping Stones Swing Tight Rope Tilden Tower Grid Treble CR Wit Zari CR	D Compass CR Coterie Eclat Weave Hologram Island Masquerade Menagerie Origins Woodland Zoom	E Aegean Cleo Demure Highland Ikati Stripe Juno Katazome Kimono Mamba Marquee Meroe Midpoint Nature Walk Sherman Shima Tryst Vatera Whip	F Atelier Biscayne Calais Cotton Velvet Cornaro Glider Icon Intrigue In Stitches Jasmine Liberty Mod Plaid Rivington Soon Topography Totem	G Alter Ego Andissa Arber Gibson Haze Kamani Melange Modern Tweed Petite Floral Serendipity Spencer ‡ Straie Stripe Ultrasuede Utrillo	H Arno Bavaria Catwalk Constance Firefly Magritte Stretch Appeal	I Aswan Byron Cato Cummings Diamond Days Dynamic Ita Jaipur Knoll Velvet ‡ Mepal North Island Olema Piper Rutledge Sandis Tudor Vermeer Zimba	U Vicenza ‡ Volo ‡	X Ducale ‡ Ducale Velour ‡	V Acqua ‡ Andes ‡ Embossed Tipped España ‡ Hand Tipped Maremma Velluto Pelle ‡	Y Cervo Copenhagen ‡ Lucca Marissa ‡ Portofino Riva ‡ Saddle ‡ Torello



‡ Approved for Cal 133 upholstery.

Check with your KnollTextiles or Spinneybeck Representative for changes or additions.

Charles Pfister Lounge Seating

Designer(s):
Charles Pfister, 1971

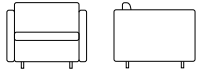
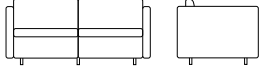

description	seat h	arm h	w	d	h	textile fabric yds.	req. leather sq. ft.	weight
1051C Standard lounge chair 	16"	24"	33 1/2"	33"	26"	7.2	130	44 lbs.
1052C Standard settee 	16"	24"	60 1/2"	33"	26"	12.4	224	73 lbs.
1053C Standard sofa 	16"	24"	87"	33"	26"	17.6	318	101 lbs.
1059C Standard ottoman 			27 1/4"	27 1/4"	16"	3.8	69	20 lbs.

pattern no.	grades A	COM B	C	D	E	F	G	H	I	COL U	V	W	X	Y
1051C	\$3,578.	\$3,864.	\$4,139.	\$4,438.	\$4,682.	\$4,862.	\$5,160.	\$5,736.	\$6,326.	\$7,906.	\$8,942.	\$11,133.	\$11,475.	\$11,986.
1052C	6,326.	6,821.	7,290.	7,807.	8,235.	8,536.	9,058.	10,044.	11,056.	13,798.	15,577.	19,359.	19,946.	20,821.
1053C	8,864.	9,567.	10,234.	10,970.	11,572.	12,004.	12,742.	14,144.	15,580.	19,523.	22,045.	27,414.	28,245.	29,493.
1059C	2,662.	2,817.	2,962.	3,119.	3,248.	3,342.	3,503.	3,803.	4,112.	5,141.	5,686.	6,848.	7,032.	7,301.

Order Code

<i>Example:</i>	1053C-MABLK
1053C	Pfister sofa
MABLK	Marissa, Black

Specify:

1. Pattern number
2. Cal 133 Fire Code option
3. Textile selection

Ordering Information

Upholstery/COM information:

Prices shown include fabric or leather upholstery. Contact your Knoll representative for colors. Only approved KnollTextiles and Spinneybeck leathers may be ordered.

Customer's Own Material is available pending approval. Non-railroad COM fabrics will require additional yardage. For approval requirements, processing instructions and ordering information please see page 18.

Cal 133 Fire Code:

Pfister lounge seating complies with the California Technical Bulletin 133 standard if upholstered in Cal 133 approved upholstery. Specify suffix -C at end of pattern number and suffix -133 at end of textile selection. Upcharge applies, see page 19.

Maintenance:

To fluff standard Pfister cushions, turn cushion upside down occasionally. See also pages 28-29.

Note:

The Pfister Lounge Seating Collection is Greenguard certified.

Construction

Frame:

Constructed in sections with a combination plywood/hardwood seat and back.

Upholstery:

Pfister lounge seat and back cushion are fully upholstered. Double-needled top stitching on leather upholstery and on thin solid textiles. Single-needled top stitching on heavily ribbed fabrics and multicolor prints. No sag spring deck covered in black cotton textile.

Seat height:

Seat height is measured from the floor to the crown of the seat cushion. Height could vary up to 1/2" depending on leather or textile specified.

Glides:

Nylon, adjustable.

Cushion fill:

Polyester wrap; foam core with polyester fiber wrap for tight, tailored aesthetic.

Approved KnollTextiles Grades/Fabrics

A Alignment # Beacon Bocce Cat's Cradle Chance Common Ground # Commuter Cloth # Crossroad Delite Dristi Hourglass Mariner Monarch Overture Prep Soliloquy Sonnet Trophy Uni-Form	B continued Grande Grandview Helios Holbrook Journey Keaton Knoll Felt # Knoll Hopsack # Little Devil Ludlow Melody Mini Stitch Paradigm Petal Pusher Pogo # Prairie Prim # Radiance Ransom Roam Rush Hour Spark # Spree Summit Sutton Synth Tabloid Tinge Venue Versa Vinyl Westwood Wide Angle # Yeni Zipline	C Atlas Axiom Baxter Cairo Charm Circa Classic Boucle Dahlia CR Decade Dune Durand Earthwork # Echo Empire Stripe Entourage Essence Fable CR Fibra Greenwich Hudson Hula Hoop Kaleidoscope CR Kora CR Lagos Legend CR Lore CR Magnolia Metro Milestone Moto CR Noble Palisade Panache CR Pullman Quark Roundtrip Sahara Sequin CR Sinclair Smart Spectator	C continued Spot On Star Struck Stepping Stones Swing Tight Rope Tilden Tower Grid Treble CR Wit Zari CR	D Compass CR Coterie Eclat Weave Hologram Island Masquerade Menagerie Origins Woodland Zoom	E Aegean Cleo Demure Highland Ikat Stripe Juno Katazome Kimono Mamba Marquee Meroe Midpoint Nature Walk Sherman Shima Tryst Vatera Whip	F Atelier Biscayne Calais Cotton Velvet Cornaro Firefly Magritte Stretch Appeal	G Alter Ego Andissa Arber Gibson Haze Kamani Melange Modern Tweed Petite Floral Serendipity Spencer # Straie Stripe Ultrasuede Utrillo	H Arno Bavaria Catwalk Constance Firefly Magritte Stretch Appeal Aswan Byron Cato Cummings Diamond Days Dynamic Ita Jaipur Knoll Velvet # Mepal North Island Olema Piper Rutledge Sandis Tudor Vermeer Zimba	I Aswan Byron Cato Cummings Diamond Days Dynamic Ita Jaipur Knoll Velvet # Mepal North Island Olema Piper Rutledge Sandis Tudor Vermeer Zimba	U Vicenza # Volo #	V Acqua # Andes # Embossed Tipped España # Hand Tipped Maremma Velluto Pelle #	W Alaska # Amazon # Antique # Derby # Forte # Lucente # Sabrina # Umbria	X Ducale # Ducale Velour #	Y Cervo Copenhagen # Lucca Marissa # Portofino Riva # Saddle # Torello
--	---	--	---	--	--	--	---	--	--	---------------------------------	--	---	---	---





Spinneybeck Leather

U Vicenza # Volo #	V Acqua # Andes # Embossed Tipped España # Hand Tipped Maremma Velluto Pelle #	W Alaska # Amazon # Antique # Derby # Forte # Lucente # Sabrina # Umbria	X Ducale # Ducale Velour #	Y Cervo Copenhagen # Lucca Marissa # Portofino Riva # Saddle # Torello
---------------------------------	--	---	---	---

Approved for Cal 133 upholstery.





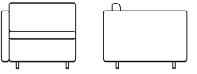



























Check with your KnollTextiles or Spinneybeck Representative for changes or additions.

Charles Pfister Sofa System

	description	seat h	arm h	w	d	h	textile fabric yds.	req. leather sq. ft.	weight
<p><i>Designer(s):</i> Charles Pfister, 1971</p> 	1050C Center module	16"		27 1/4"	33"	26"	5.2	94	28 lbs.
									
	1050C-1 End module, arm panel on right side of user	16"	24"	30 1/8"	33"	26"	6.2	112	36 lbs.
									
	1050C-2 End module, arm panel on left side of user	16"	24"	30 1/8"	33"	26"	6.2	112	36 lbs.
									
	1050C-3 Corner module	16"	24"	33"	33"	26"	7.0	126	41 lbs.
									

Order Code	Ordering Information	Construction
<i>Example:</i> 1050C-3-K349/1	<i>Upholstery/COM information:</i>	<i>Cal 133 Fire Code</i>  :
1050C-3 Pfister corner module	Prices shown include fabric or leather upholstery. Contact your Knoll representative for colors. Only approved KnollTextiles and Spinneybeck leathers may be ordered. Note: Non-railroad COM fabrics will require additional yardage.	The Pfister Collection complies with the California Technical Bulletin 133 standard if upholstered in Cal 133 approved upholstery. Specify polyester fiber wrap and suffix -C at end of pattern number and suffix -133 at end of textile selection. Upcharge applies, see page 18.
K349/1 Alignment, Sand	Customer's Own Material is available pending approval. For approval requirements, processing instructions and ordering information please see page 18.	<i>Frame:</i> Constructed in sections with a combination plywood/hardwood seat and back.
<i>Specify:</i>		<i>Upholstery:</i> Pfister sofa system cushions are fully upholstered. Coverings are upholstered on both sides in fabric or leather. Double-needled top stitching on leather upholstery and thin solid textiles. Single-needled top stitching on heavily ribbed fabrics and multicolor prints. No sag spring deck covered in black cotton textile.
1. Pattern number		<i>Cushion fill:</i> Polyester wrap: foam core with polyester fiber wrap for tight, tailored aesthetic.
2. Cal 133 Fire Code option		<i>Glides:</i> Nylon, adjustable.
3. Textile selection		
	<i>Note:</i> Modules shipped with unupholstered sides unless specified. For upholstered sides, contact your Knoll representative for pricing. All modules shipped knocked-down (KD), assembly required.	
	<i>Note:</i> The Pfister Sofa System is Greenguard certified.	

pattern no.	grades A	COM B	C	D	E	F	G	H	I	COL U	V	W	X	Y
1050C	\$2,728.	\$2,937.	\$3,130.	\$3,350.	\$3,528.	\$3,657.	\$3,873.	\$4,291.	\$4,713.	\$5,996.	\$6,741.	\$8,256.	\$8,575.	\$8,945.
1050C-1	3,385.	3,635.	3,870.	4,133.	4,341.	4,496.	4,752.	5,250.	5,753.	7,330.	8,220.	10,027.	10,402.	10,842.
1050C-2	3,385.	3,635.	3,870.	4,133.	4,341.	4,496.	4,752.	5,250.	5,753.	7,330.	8,220.	10,027.	10,402.	10,842.
1050C-3	4,179.	4,460.	4,723.	5,018.	5,258.	5,430.	5,722.	6,281.	6,850.	8,711.	9,707.	11,741.	12,167.	12,659.



Approved KnollTextiles Grades/Fabrics				Spinneybeck Leather			
A	B	C	C continued	E	G	U	V
Alignment 	Journey	Atlas	Spectator	Vatera	Serendipity	Vicenza 	Ducale 
Beacon	Keaton	Axiom	Spot On	Whip	Spencer 	Volo 	Ducale Velour 
Bocce	Knoll Felt 	Baxter	Star Struck		Straie Stripe		
Cat's Cradle	Knoll Hopsack 	Cairo	Stepping Stones	F	Ultrasuede	V	Y
Chance	Little Devil	Charm	Swing	Atelier	Utrillo	Acqua 	Cervo
Common Ground 	Ludlow	Circa	Tight Rope	Biscayne		Andes 	Copenhagen 
Commuter Cloth 	Melody	Classic Boucle	Tilden	Calais Cotton	H	Embossed Tipped	Distressed 
Crossroad	Mini Stitch	Dahlia CR	Tower Grid	Velvet	Arno	España 	Lucca
Delite	Paradigm	Decade	Treble CR	Cornaro	Bavaria	Hand Tipped	Marissa 
Dristi	Petal Pusher	Dune	Wit	Glider	Catwalk	Maremma	Portofino
Hourglass	Pogo 	Durand	Zari CR	Icon	Constance	Velluto Pelle 	Riva 
Mariner	Prairie	Earthwork 		Intrigue	Firefly	Saddle 	Torello
Monarch	Prim 	Echo		In Stitches	Magritte		
Overture	Radiance	Empire Stripe	D	Jasmine	Stretch Appeal	W	
Prep	Ransom	Entourage	Compass CR	Liberty		Alaska 	
Soliloquy	Roam	Essence	Coterie	Mod Plaid	I	Amazon 	
Sonnet	Rush Hour	Fable CR	Eclat Weave	Rivington	Aswan	Antique 	
Trophy	Spark 	Fibra	Hologram	Soon	Byron	Derby 	
Uni-Form	Spree	Greenwich	Island	Topography	Cato	Forte 	
	Summit	Hudson	Masquerade	Totem	Cummings	Lucente 	
	Sutton	Hula Hoop	Menagerie		Diamond Days	Sabrina 	
	Synth	Kaleidoscope CR	Origins	G	Dynamic	Umbria	 Approved for Cal 133 upholstery.
	Tabloid	Kora CR	Woodland	Alter Ego	Ita		
	Tinge	Lagos	Zoom	Andissa			
	Venue	Legend CR		Arber			
	Versa	Lore CR	E	Gibson			
	Vinyl	Magnolia	Aegean	Haze			
	Westwood	Metro	Cleo	North Island			
	Wide Angle 	Milestone	Demure	Olema			
	Yeni	Moto CR	Highland	Piper			
	Zipline	Noble	Ikat Stripe	Rutledge			
		Palisade	Juno	Sandis			
		Panache CR	Katazome	Tudor			
		Pullman	Kimono	Vermeer			
		Quark	Mamba	Zimba			
		Roundtrip	Marquee				
		Sahara	Meroe				
		Sequin CR	Midpoint				
		Sinclair	Nature Walk				
		Smart	Sherman				
			Shima				
			Tryst				

Warren Platner Seating Collection

Designer(s):
Warren Platner, 1962

Award(s):
1966 American Institute of Architects International Award

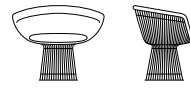

description	seat h	w	d	h	frame	textile fabric yds.	req. leather sq ft	weight
1715L Lounge chair 	18 1/2"	36 1/2"	25 1/2"	30 1/4"	nickel	4.0	n/a	37 lbs.
	18 1/2"	36 1/2"	25 1/2"	30 1/4"	bronze	4.0	n/a	37 lbs.
	18 1/2"	36 1/2"	25 1/2"	30 1/4"	gold	4.0	n/a	37 lbs.
1725A Arm chair 	19"	26 1/2"	22"	28 3/4"	nickel	1.8	35	21 lbs.
	19"	26 1/2"	22"	28 3/4"	bronze	1.8	35	21 lbs.
	19"	26 1/2"	22"	28 3/4"	gold	1.8	35	21 lbs.
1719Y Stool 	22 3/4"	15 1/4"		22 3/4"	nickel	1.1	20	12 lbs.
	22 3/4"	15 1/4"		22 3/4"	bronze	1.1	20	12 lbs.
	22 3/4"	15 1/4"		22 3/4"	gold	1.1	20	12 lbs.

Order Code

<i>Example:</i>	1725A-N-H800/2
1725A	Platner Arm Chair
N	Nickel Frame
H800/2	Cato, Sand

Note:
Platner lounge seating is part of a collection. Please refer to Platner Easy Chair and Ottoman on page 216 and Platner tables on page 356.

Specify:
1. Pattern number
2. Frame finish
3. Textile selection

Ordering Information

Frame:
Metallic Bronze (suffix BRM)
Polished Nickel (suffix N)
18k Gold Plated (suffix GLD)

Upholstery/COM information:
Prices shown include fabric or leather upholstery. Contact your Knoll representative for colors. Only approved KnollTextiles and Spinneybeck leathers may be ordered.

Customer's Own Material is available pending approval. For approval requirements, processing instructions and ordering information please see page 18.

Cal 133 Fire Code:
The Platner Seating Collection complies with the California Technical Bulletin 133 standard if upholstered in Cal 133 approved upholstery. Specify suffix -C at end of pattern number and suffix -133 at end of textile selection. Upcharge applies, see page 19.

Maintenance:
See pages 28-29.

Note:
The Platner Seating Collection is Greenguard certified.

Construction

Frame:
Forms created by vertical steel wire rods welded to circular horizontal and edge-framing rods. Finish in bright nickel with clear lacquer protection, painted bronze metallic, or plated in 18k gold.

Base:
Clear plastic extrusion ring for smooth bottom surface.

Upholstery:
Molded fiberglass shell with molded latex foam cushion. Cushions with latex core and zipper cover attach to seat with Velcro.

pattern no.	grades A	COM B	C	D	E	F	G	H	I	COL U	V	W	X	Y
1715L-N(-)	\$8,602.	\$8,728.	\$8,852.	\$8,985.	\$9,094.	\$9,172.	\$9,308.	\$9,563.	\$9,750.					
1715L-BRM(-)	9,089.	9,215.	9,339.	9,471.	9,582.	9,661.	9,793.	10,050.	10,236.					
1715L-GLD(-)	11,471.	11,564.	11,667.	11,788.	11,958.	12,057.	12,228.	12,344.	12,686.					
1725A-N(-)	4,937.	4,995.	5,049.	5,110.	5,160.	5,196.	5,256.	5,372.	5,456.	5,797.	6,020.	6,470.	6,563.	6,674.
1725A-BRM(-)	5,330.	5,387.	5,443.	5,504.	5,555.	5,591.	5,648.	5,765.	5,850.	6,193.	6,413.	6,865.	6,961.	7,068.
1725A-GLD(-)	7,199.	7,240.	7,286.	7,342.	7,418.	7,462.	7,539.	7,592.	7,746.	11,080.	11,237.	11,555.	11,621.	11,699.
1719Y-N(-)	2,787.	2,820.	2,854.	2,890.	2,920.	2,943.	2,980.	3,050.	3,102.	3,273.	3,399.	3,658.	3,712.	3,775.
1719Y-BRM(-)	2,909.	2,944.	2,976.	3,014.	3,044.	3,066.	3,104.	3,173.	3,226.	3,397.	3,522.	3,781.	3,834.	3,898.
1719Y-GLD(-)	4,176.	4,202.	4,229.	4,263.	4,310.	4,337.	4,385.	4,416.	4,509.	6,381.	6,470.	6,652.	6,690.	6,735.

Approved KnollTextiles Grades/Fabrics

- A** Beacon
Bocce
Cat's Cradle
Chance
Common Ground
Commuter Cloth
Crossroad
Delite
Dristi
Hourglass
Mariner
Monarch
Overture
Soliloquy
Sonnet
Trophy
- B** Abacus
Argyle
Bank Shot
Belize
Bistro **
Boundary
Calypso *
Cameo
Chroma
Chronicle
Close Knit *
Diva
Dovetail
Ferry
Gala II
Grande
Grandview
Holbrook
Journey
Keaton
Knoll Felt †
Knoll Hopsack †
Little Devil
Ludlow
Melody
Mini Stitch
- C** continued
Greenwich
Hudson
Hula Hoop
Kaleidoscope CR *
Kora CR **
Lagos **
Legend CR *
Magnolia
Metro
Milestone
Moto CR **
Noble
Palisade
Panache CR *
Quark
Roundtrip
Sahara **
Sequin CR
Sinclair **
Smart
Spectator
Spot On
Star Struck
Stepping Stones **
Swing
Tight Rope **
Tilden **
Tower Grid
Treble CR
Wit
Zari CR **
- D** continued
Origins
Woodland **
Aegean
Cleo
Demure
Highland
Ikat Stripe
Juno
Katazome
Kimono
Mamba
Marquee
Meroe
Midpoint *
Sherman **
Shima
Tryst
Vatera
Whip
- E** continued
Axiom
Baxter
Cairo
Charm
Circa
Classic Boucle
Dahlia CR
Dune
Durand **
Earthwork
Echo
Enmesh
Entourage
Essence
Fable CR
Fibra
- F** continued
Atelier
Biscayne
Cornaro
Glider
Icon
Intrigue
Jasmine
Liberty
Mod Plaid
Rivington
Soon **
Topography
Totem
Tweed Frieze
- G** Alter Ego
Arber
Gibson
Haze
Kamani
Melange
Petite Floral
Serendipity
Spencer
Straie Stripe
Ultrasuede
Utrillo
- H** Arno
Bavaria
Constance
Firefly
Magritte
- I** Aswan * *
Byron
Cato
Cummings * *
Diamond Days
Dynamic
Ita
Jaipur
Knoll Velvet
Limani
Mepal * *
North Island
Olema
Piper
Rutledge
Sandis * *
Tudor
Vermeer
Zimba
- U** Vicenza **
Volo **
- V** Acqua **
Andes **
Embossed
Tipped * *
España * *
Hand Tipped * *
Maremma * *
Velluto Pelle * *
- W** Alaska * *
Amazon * *
Antique * *
Derby * *
Forte * *
Lucente
Sabrina * *
- X** Ducale **
Ducale Velour * *
- Y** Cervo * *
Copenhagen * *
Distressed * *
Gemma * *
Lucca
Marissa * *
Portofino * *
Riva * *
Saddle * *
Torello * *

Spinneybeck Leather

† Approved for 1719Y stool only
* * Not approved for 1715L lounge chair
‡ Approved for Cal133 upholstery

Check with your KnollTextiles or Spinneybeck Representative for changes or additions.

Warren Platner

Easy Chair and Ottoman

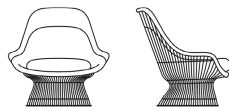
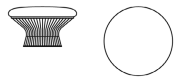
	description	seat h	w	d	h	frame	textile fabric yds.	weight
<i>Designer(s):</i> Warren Platner, 1962	1705L Easy Chair 	18 3/4"	39 7/8"	37"	38 3/4"	nickel	7.0	n/a
	1709Y Ottoman 	—	26 3/4"	26 3/4"	16 7/8"	nickel	2.75	n/a



pattern no.	grades	COM	C	D	E	F	G	H	I
1705L-N	\$13,460.	\$13,633.	\$13,798.	\$13,981.	\$14,129.	\$14,238.	\$14,420.	\$14,768.	\$15,023.
1709Y-N	3,689.	3,758.	3,823.	3,896.	3,953.	3,996.	4,067.	4,204.	4,306.

Order Code	Ordering Information	Construction
<i>Example:</i> 1705L-N-H800/2 1705L Platner Easy chair N Nickel frame H800/2 Cato, Sand	<i>Frame:</i> Polished Nickel (suffix N) <i>Upholstery/COM information:</i> Prices shown include fabric upholstery. Contact your Knoll representative for colors. Only approved KnollTextiles may be ordered. All textiles will be cut railroad. Customer's Own Material is available pending approval. For approval requirements, processing instructions and ordering information please see page 18. <i>Cal 133 Fire Code</i> †: The Easy Chair and Ottoman comply with the California Technical Bulletin 133 standard if upholstered in Cal 133 approved upholstery. Specify suffix -C at end of pattern number and suffix -133 at end of textile selection. Upcharge applies, see page 19.	<i>Maintenance:</i> See pages 28-29. <i>Note:</i> The Platner Easy Chair and Ottoman are Greenguard certified. <i>Construction:</i> Hand bent vertical steel wire rods welded to circular horizontal and edge-framing rods. Finish in bright nickel with a clear lacquer protection. Clear plastic extrusion ring for a smooth bottom surface. Molded fiberglass shell with highly resilient molded urethane foam cushions. Seat and ottoman cushion utilize the same highly resilient molded urethane foam cushion.

Note:
 Platner Easy Chair and Ottoman is part of a collection. Please refer to Platner Seating Collection on page 214 and Platner tables on page 356.

- Specify:*
1. Pattern number
 2. Frame finish
 3. Textile selection

Approved KnollTextiles Grades/Fabrics					
A Bocce Cat's Cradle Common Ground † Commuter Cloth Delite Hourglass Monarch Sonnet Trophy Uni-Form	B continued Melody Mini Stitch Paradigm Petal Pusher Pogo Prim Radiance Ransom Roam Spark Spree Summit Yeni Zipline	C continued Hudson Hula Hoop Metro Milestone Pullman Quark Roundtrip Smart Star Struck Swing Tight Rope Tower Grid Treble CR Wit	D continued Highland Ikat Stripe Juno Katazome Kimono Mamba Marquee Meroe Shima Whip	E continued Alter Ego Gibson Haze Kamani Melange Modern Tweed Petite Floral Serendipity Spencer Straie Stripe Ultrasuede Utrillo	F Atelier Biscayne Glider Icon Intrigue In Stitches Liberty Mod Plaid Rivington Topography
B Abacus Argyle Belize Boundary Cameo Chronicle Diva Dovetail Ferry Grande Grandview Holbrook Journey Keaton Knoll Felt † Knoll Hopsack † Little Devil Ludlow	C Charm Circa Classic Boucle † Dahlia CR Dune Earthwork Echo Essence Fibra Greenwich	D Eclat Weave Hologram Menagerie Origins	E Aegean Cleo Demure	G Arno Bavaria Catwalk Constance Firefly Magritte	H Cato Diamond Days Dynamic Jaipur Knoll Velvet Limani North Island † Olema Piper Rutledge Vermeer Zimba

† Approved for Cal 133 upholstery

Charles Pollock

Executive Conference Arm and Armless Chairs

Designer(s):
Charles Pollock, 1963



description	seat h	arm h	w	d	h	textile fabric yds.	req. leather sq. ft.	weight
12A-(1, 2, 3 or 4)-D5G-H Arm chair, swivel/tilt, pneumatic height, seat height adjustment	18"-23"	24"-29"	26 1/4"	28 1/4"	31"-36"	1.1	20	44 lbs.
								44 lbs.
12C-(1, 2, 3 or 4)-D5G-H Armless chair, swivel/tilt, pneumatic height, seat height adjustment	18"-23"		23 1/2"	28 1/4"	31"-36"	1.1	20	41 lbs.
								41 lbs.
R Optional casters for hard floors (substitute -R for -H in pattern number)								
1250COVER Replacement cover						1.1	20	
1250BUTTON Replacement buttons (specify upholstery)								



Order Code	Ordering Information	Construction
<i>Example:</i> 12A-1-D5G-H-AM3030	<i>Frame/base top cap finishes:</i> Polished aluminum/stainless steel (suffix 1) Satin anodized aluminum/brushed stainless steel (suffix 2) Black anodized aluminum/black epoxy (suffix 3) Black anodized aluminum/stainless steel (suffix 4)	<i>Outer shell:</i> Integrally colored, black textured polypropylene. <i>Frame:</i> Extruded aluminum with polished, satin or black anodized finish. Steel support plate spans the width of the seat cushion. <i>Upholstery:</i> Multi-density urethane foam (4 1/2" maximum thickness); button tufting on fabric and leather detail. <i>Arms:</i> Seamless, black phenolic plastic. <i>Column cover:</i> Polypropylene on pneumatic seat height models; steel with epoxy finish on mechanical seat height models. <i>Base:</i> Steel armature with epoxy finish; polished stainless or black epoxy finished top caps. Standard five-star design.
12A Pollock arm chair		<i>Standard casters:</i> Hard wheel casters standard. <i>Controls:</i> 360° swivel; tilt with tilt tension and pneumatic seat height adjustment. <i>Replacement buttons:</i> Set of 6 buttons for one chair. <i>Replacement cover:</i> Must be installed by an upholsterer.
1 Polished aluminum frame/stainless steel base top caps		
D5G Swivel/tilt control with pneumatic seat height adjustment	<i>Upholstery/COM information:</i> Prices shown include fabric or leather upholstery. Contact your Knoll representative for colors. Only approved KnollTextiles and Spinneybeck leathers may be ordered. Customer's Own Material is available pending approval. For approval requirements, processing instructions and ordering information please see page 18. <i>Maintenance:</i> See pages 28-29. <i>Cal 133 Fire Code:</i> The Pollock Chair complies with the California Technical Bulletin 133 standard if upholstered in Cal 133 approved upholstery. Specify suffix -C at end of pattern number and suffix -133 at end of textile selection. Upcharge applies, see page 19. <i>Note:</i> The Pollock Executive Conference Arm and Armless Chair is Greenguard certified.	
H Hard-wheel casters		
AM3030 Amazon, Bossa Nova		

Specify:

1. Pattern number
2. Frame/base top cap finish
3. Cal 133 Fire Code option
4. Textile selection

pattern no.	grades	COM									COL				
	A	B	C	D	E	F	G	H	I	U	V	W	X	Y	
12A-(1 or 2)-D5G-H	\$3,060.	\$3,110.	\$3,155.	\$3,193.	\$3,223.	\$3,251.	\$3,282.	\$3,358.	\$3,498.	\$3,628.	\$3,792.	\$4,168.	\$4,234.	\$4,273.	
12A-(3 or 4)-D5G-H	2,799.	2,849.	2,896.	2,933.	2,964.	2,992.	3,021.	3,098.	3,240.	3,368.	3,534.	3,906.	3,975.	4,014.	
12C-(1 or 2)-D5G-H	2,810.	2,857.	2,904.	2,935.	2,966.	2,993.	3,021.	3,097.	3,230.	3,358.	3,515.	3,876.	3,942.	3,977.	
12C-(3 or 4)-D5G-H	2,564.	2,609.	2,654.	2,687.	2,719.	2,746.	2,774.	2,849.	2,984.	3,111.	3,266.	3,630.	3,697.	3,728.	
R	n/c														
1250COVER	478.	524.	567.	598.	628.	651.	679.	751.	879.	992.	1,144.	1,486.	1,548.	1,582.	
1250BUTTON- ()	59.	59.	59.	59.	59.	59.	59.	59.	59.	86.	86.	86.	86.	86.	

Approved KnollTextiles Grades/Fabrics						Spinneybeck Leather						
A Beacon Bocce Cat's Cradle Chance Common Ground [‡] Commuter Cloth [‡] Crossroad Delite Dristi Hourglass Mariner Monarch [‡] Overture Prep [‡] Presto [‡] Soliloquy Sonnet Trophy Uni-Form	B continued Paradigm Petal Pusher Pogo [‡] Prairie Prim Radiance Ransom Roam Rush Hour Spark [‡] Spree Summit Sutton Synth Tabloid Tinge Venue Versa Vinyl Westwood Wide Angle [‡] Zipline	C continued Fibra Greenwich Hudson Hula Hoop Kora CR Lagos Legend CR Lore CR Magnolia Metro Milestone Moto CR Noble Palisade Panache CR Pullman Quark Roundtrip Sequin CR Sinclair Smart Spectator Spot On Star Struck Stepping Stones Swing Tight Rope Tower Grid Tilden Treble CR Wit Zari CR	D Compass CR Coterie Eclat Weave Hologram In The Loop Island Masquerade Menagerie Origins Woodland Zoom	E Aegean Cleo Demure Highland Ikat Stripe Juno Katazome Kimono Mamba Marquee Meroe Midpoint Nature Walk Sherman Shima Tryst Vatera Whip	F Atelier Biscayne Cornaro Clider Icon Intrigue In Stitches Liberty Mod Plaid Rivington Topography Totem Tweed Frieze	H Arno Bavaria Catwalk Constance Firefly Magritte Stretch Appeal	I Aswan Byron Cato Diamond Days Dynamic Ita Jaipur Knoll Velvet Limani North Island Olema Piper Rutledge Tudor Vermeer Zimba	U Vicenza [‡] Volo [‡]	V Acqua [‡] Andes [‡] España [‡] Hand Tipped Velluto Pelle [‡]	W Alaska [‡] Amazon [‡] Antique [‡] Derby [‡] Forte [‡] Lucente Sabrina [‡] Umbria	X Ducale [‡] Ducale Velour [‡]	Y Cervo Copenhagen [‡] Distressed Gemma Lucca Marissa [‡] Portofino Riva [‡] Torello
[‡] Approved for Cal 133 upholstery.												
<i>Check with your KnollTextiles or Spinneybeck Representative for changes or additions.</i>												

Charles Pollock
Arm Chair

	description	seat h	arm h	w	d	h	weight
<i>Designer(s):</i> Charles Pollock, 1960	657 Arm Chair	16 1/4"	22 3/4"	25"	26"	27 3/4"	32 lbs.

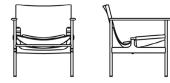

pattern no.	
657-(BL_) - (PT_, HT_)	\$3,862.

Order Code

<i>Example:</i> 657-BL-PT
657 arm chair
BL belting leather
PT Portofino

Specify:

1. Pattern number
2. Belting leather selection
3. Cushion upholstery selection

Ordering Information

Frame finishes:
Chrome/black

Sling upholstery:
Spinneybeck Belting Leather (suffix BL_)

Seat pad:
Spinneybeck Portofino (suffix PT_)
Spinneybeck Hand Tipped (suffix HT_)

Upholstery note:
No Customer's Own Materials can be used.

Replacement slings:
Knoll does not recommend replacement slings. This procedure requires the chair to be disassembled and rebuilt, a complex and time consuming process.

Maintenance:
See pages 28-29.

Please ask your Spinneybeck Representative for samples of the belting leather.

Construction

Frame:
Tubular steel legs, polished chrome finish. Cast aluminum arms and stretchers, black painted finish. Stamped steel glides.

Upholstery:
Belting leather sling. Cushion is urethane foam upholstered in Portofino or Hand Tipped leather.

Carlos Riart Riart Rocker

description	seat h	arm h	w	d	h	textile fabric yds.	req. leather sq. ft.	weight
790 Riart Rocker	21"	24½"	24¼"	42½"	38¼"	2	38	25 lbs.

Designer(s):
Carlos Riart, 1982

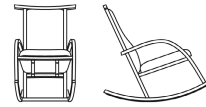

pattern no.	grades A	COM B	C	D	E	F	G	H	I	COL U	V	W	X	Y
790-(-)	\$5,501.	\$5,552.	\$5,600.	\$5,652.	\$5,697.	\$5,728.	\$5,783.	\$5,884.	\$5,960.	\$6,540.	\$6,734.	\$7,127.	\$7,208.	\$7,304.

Order Code

<i>Example:</i>	790-LWT-K1320/6
790	Riart Rocker
LWT	Light Walnut
K1320/6	Cornaro, Meadow

Ordering Information

Walnut with light lacquer finish:
Light Walnut (suffix LWT)

Medium Figured English Sycamore:
Sycamore (suffix S515)

Specify:

1. Pattern number
2. Finish selection
3. Textile selection

Construction

Frame:
Solid lumber frame construction with laminated runners and arms.

Upholstery:
High density, polyurethane foam used in all upholstered areas. Elastic seat belt suspension.

Inlays:
Mother of Pearl inlays for product specified in Light Walnut. Ebony inlays for product in Sycamore.

Upholstery/COM information:
Prices shown include fabric or leather upholstery. Contact your Knoll representative for colors. Only approved KnollTextiles and Spinneybeck leathers may be ordered.

Customer's Own Material is available pending approval. For approval requirements, processing instructions and ordering information please see page 18.

Maintenance:
See pages 28-28.

Note:
Carlos Riart's signature is engraved in each chair.

The Riart Rocker is Greenguard approved.

Approved KnollTextiles Grades/Fabrics

A Cat's Cradle Chance Common Ground Hourglass Mariner Presto Sonnet	B Abacus Belize Chronicle Dovetail Ferry Gala II Grande Grandview Knoll Felt	C continued Melody Petal Pusher Pogo Prairie Tinge Venue Vinyl Westwood	C continued Kaleidoscope CR Kaya CR Lore CR Palisade Panache CR Quark Roundtrip Sahara Sequin CR Smart Spot On Swing Tilden Treble CR Zari CR	D Compass CR Eclat Weave Hologram Masquerade Zoom	E Highland Katazome Shima Tryst	F Atelier Calais Cotton Velvet Cornaro Icon Intrigue Rivington Tweed Frieze	G Gibson Haze Kamani Melange Serendipity Ultrasuede	H Arno	I Cato Knoll Velvet Rutledge Tudor
---	--	--	---	---	--	--	--	------------------	---

Spinneybeck Leather

U Vicenza Volo	V Acqua Andes España Velluto Pelle	W Alaska Antique Forte Lucente Sabrina	Y Copenhagen Gemma Marissa Riva
-----------------------------	---	--	--

Check with your KnollTextiles or Spinneybeck Representatives for changes or additions.

Joe Ricchio Joe™ Chair



description	seat h	arm h	w	d	h	textile	req.	weight	finish
						fabric yds.	leather sq. ft.		
48A Joe arm chair	19"	26"	24"	22"	32"	0.8	14.5	16 lbs.	other stains
	19"	26"	24"	22"	32"	0.8	14.5	16 lbs.	maple, ebonized
48R Seat basket replacement for 48A						0.8	13		

Designer(s):
Joe Ricchio

Order Code	Ordering Information	Construction
<i>Example:</i> 48A-BN-K224/1	<i>Maple:</i> Clear Maple (suffix KC)	<i>Frame:</i> Select maple hardwood in clear or beech hardwood in stained finish.
48A Joe arm chair	<i>Beech frame stains:</i> Beech (suffix B311) Bronzed Cherry (suffix B312A) Burnt Walnut (suffix B313) Deep Red Mahogany (suffix B328) Ebonized (suffix BE) Light Cherry (suffix B315) Medium Cherry (suffix B319) Medium Red Mahogany (suffix BR) Medium Walnut (suffix B323) Natural Beech (suffix BN) Warm Brown Walnut (suffix J)	<i>Upholstered seat:</i> Elastic seat belt suspension, high resilient foam. Seat basket is 1.25" thick.
BN Natural Beech	<i>Cal 133 Fire Code:</i> The Joe Chair complies with the California Technical Bulletin 133 standard if upholstered in Cal 133 approved upholstery. Specify suffix -C at end of pattern number and suffix -133 at end of textile selection. Upcharge applies, see page 19.	
K224/1 Wide Angle, Castor	<i>Certified Wood:</i> Chairs manufactured using FSC certified hardwoods are available through Custom Product Development. Extended leadtime and upcharge apply.	
<i>Specify:</i> 1. Pattern number 2. Finish 3. Cal 133 fire code option 4. Textile selection	<i>Maintenance:</i> See pages 28-29.	
	<i>Note:</i> The Joe Chair is Greenguard certified.	
	<i>KnollStudio wood finishes:</i> KnollStudio wood finishes complement a large variety of KnollStudio veneer and Knoll Office veneer finishes. To select correct complementary finish, please refer to KnollStudio Wood Finish Matrix on page 25. If no complementary standard finish is available, please refer to custom finish policy below.	

pattern no.	grades	COM	C	D	E	F	G	H	I	COL	U	V	W	X	Y
48A-()	\$1,187.	\$1,215.	\$1,242.	\$1,271.	\$1,294.	\$1,309.	\$1,335.	\$1,394.	\$1,434.	\$1,569.	\$1,668.	\$1,871.	\$1,913.	\$1,960.	
48A-(KC, BE)	1,368.	1,395.	1,422.	1,450.	1,474.	1,488.	1,516.	1,576.	1,615.	1,748.	1,849.	2,052.	2,094.	2,141.	
48R-()	241.	270.	295.	327.	350.	366.	400.	450.	497.	640.	742.	955.	998.	1,048.	

Approved KnollTextiles Grades/Fabrics				Spinneybeck Leather										
A Alignment # Beacon Bocce Cat's Cradle Chance Common Ground # Commuter Cloth # Crossroad Delite Dristi Foil Rap Heavy Metal Hourglass Mariner Monarch # Overture Prep # Presto # Soliloquy Sonnet Trophy Uni-Form	B Abacus # Argyle Backdrop Belize Bistro # Boundary # # Cameo Chroma # Chronicle Close Knit Digital Tape Diva Dovetail # Fast Forward Ferry	C Atlas Axiom Baxter Cairo Charm # Circa Classic Boucle Dahlia CR Decade Dune Durand Earthwork # Echo Empire Stripe Enmesh # Entourage Essence Fable CR Fibra Greenwich Hudson Hula Hoop # Kaleidoscope CR Kaya CR Kora CR Lagos Legend CR Lore CR Magnolia Metro Milestone Moto CR # Noble Palisade Panache CR Pullman Quark	D Compass CR Coterie Eclat Weave Hologram # In The Loop Island Kabuki Masquerade Menagerie Origins Woodland Zoom	E Aegean Demure Highland Ikat Stripe Juno Katazome Kimono Mamba Marquee Meroe Midpoint Nature Walk Sherman Shima Tryst Vatera Whip	F Atelier Biscayne Calais Cotton Velvet Cornaro Glider Icon # Intrigue In Stitches Liberty Mod Plaid Rivington Soon Topography Totem Tweed Frieze	G Alter Ego Andissa Arber	G continued Gibson Haze Kamani Melange Modern Tweed Petite Floral Serendipity Straie Stripe Ultrasuede # Utrillo	H Arno Bavaria Catwalk Constance Firefly Magritte Stretch Appeal	I Aswan Byron Cato Cummings Diamond Days Dynamic Jaipur Knoll Velvet Mepal North Island Olema Piper Rutledge Sandis Tudor Vermeer Zimba	U Vicenza # Volo #	V Acqua # Andes # Embossed Tipped España # Hand Tipped # Maremma # Velluto Pelle #	W Alaska # Amazon # Antique # Derby # Forte # Lucente # Sabrina # Umbria	X Ducale # Ducale Velour #	Y Cervo Copenhagen # Distressed # Gemma Lucca Marissa # Portofino # Riva # Saddle # Torello
				# Approved for Cal 133 upholstery.										
				<i>Check with your KnollTextiles or Spinneybeck Representative for changes or additions.</i>										

Joe and Linda Ricchio JR® and Ricchio Chair with Upholstered Seat

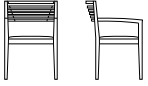
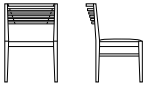
	description	seat h	arm h	w	d	h	textile fabric yds.	req. leather sq. ft.	weight	finish
<i>Designer(s):</i> Joseph and Linda Ricchio, 1990	37A Arm chair 	18"	25 1/4"	21 1/4"	23 1/2"	32 1/4"	0.7	13	17 lbs.	maple, ebonized
		18"	25 1/4"	21 1/4"	23 1/2"	32 1/4"	0.7	13	17 lbs.	other finishes
<i>Award(s):</i> Roscoe, 1991	37C Armless chair 	18"		21 1/4"	23 1/2"	32 1/4"	0.7	13	15 lbs.	maple, ebonized
		18"		21 1/4"	23 1/2"	32 1/4"	0.7	13	15 lbs.	other finishes
	T Thick seat option (add -T to end of pattern number)									
	37R-T Thick seat basket replacement for 37A and 37C						0.7	13		
	37R Seat basket replacement for 37A and 37C						0.7	13		





Order Code	Ordering Information	Construction
<i>Example:</i> 37A-T-BN-K1320/4	<i>Upholstery/COM information:</i>	<i>Cal 133 Fire Code #:</i>
37A Arm chair	Prices shown include fabric or leather upholstery. Contact your Knoll representative for colors. Only approved KnollTextiles and Spinneybeck leathers may be ordered.	The JR and Ricchio Chairs comply with the California Technical Bulletin 133 standard if upholstered in Cal 133 approved upholstery. Specify suffix -C at end of pattern number and suffix -133 at end of textile selection. Upcharge applies, see page 19.
T Thick seat	Customer's Own Material is available pending approval. For approval requirements, processing instructions and ordering information please see page 18.	<i>Certified Wood:</i> Chairs manufactured using FSC certified hardwoods are available through Custom Product Development. Extended leadtime and upcharge apply.
BN Natural Beech	<i>KnollStudio wood finishes:</i> KnollStudio wood finishes complement a large variety of KnollStudio veneer and Knoll Office veneer finishes. To select correct complementary finish, please refer to KnollStudio Wood Finish Matrix on page 25. If no complementary standard finish is available, please refer to custom finish policy below.	<i>Maintenance:</i> See pages 28-29.
K1320/4 Cornaro, Tabasco	<i>Custom finishes:</i> Complementary finishes to any KnollStudio or Knoll Office wood finish are available at no upcharge. To complement non-Knoll wood veneer or lumber finishes, a one-time, non-negotiable net upcharge of \$662 applies. Re-orders are at no upcharge. Please contact your KnollStudio representative, dealer or Customer Service associate for complete custom finish information and Order Code. Minimum order quantity for any custom finish order: 4 chairs.	<i>Seat Basket Replacement:</i> Upholstered seat sits on chair frame. Screws lock basket in place for easy installation or removal. For seat basket replacements for JR chairs ordered prior to February 2007, specify pattern numbers 37R-S. Pricing for 44R will apply.
<i>Specify:</i>		<i>Finish:</i> Catalyzed lacquer protective coating. Hand-applied final wax coating.
1. Pattern number		<i>Glides:</i> Recessed plastic glides.
2. Thick seat option (Ricchio chair only)		
3. Finish selection		
4. Cal 133 Fire Code option		
5. Textile selection		
<i>Maple:</i> Clear Maple (suffix KC)		
<i>Beech frame stains:</i> Beech (suffix B311) Bronzed Cherry (suffix B312A) Burnt Walnut (suffix B313) Deep Red Mahogany (suffix B328) Ebonized (suffix BE) Light Cherry (suffix B315) Medium Cherry (suffix B319) Medium Red Mahogany (suffix BR) Medium Walnut (suffix B323) Natural Beech (suffix BN) Warm Brown Walnut (suffix J)		
	JR Chair (44A) does not stack.	

pattern no.	upcharge	grades A	COM B	C	D	E	F	G	H	I	COL U	V	W	X	Y
37A-(KC, BE)		\$1,355.	\$1,384.	\$1,405.	\$1,435.	\$1,462.	\$1,476.	\$1,506.	\$1,561.	\$1,602.	\$1,775.	\$1,881.	\$2,086.	\$2,128.	\$2,179.
37A-()		1,289.	1,317.	1,335.	1,368.	1,394.	1,409.	1,437.	1,496.	1,535.	1,708.	1,814.	2,020.	2,061.	2,110.
37C-(KC, BE)		1,272.	1,300.	1,325.	1,354.	1,380.	1,393.	1,424.	1,479.	1,519.	1,694.	1,797.	2,002.	2,046.	2,096.
37C-()		1,210.	1,241.	1,262.	1,292.	1,318.	1,330.	1,361.	1,419.	1,458.	1,631.	1,737.	1,941.	1,983.	2,033.
T	29.														
37R-T-()		286.	316.	340.	364.	390.	408.	437.	493.	532.	707.	811.	1,018.	1,061.	1,110.
37R-()		257.	287.	311.	335.	361.	380.	408.	465.	504.	678.	782.	989.	1,032.	1,081.

Approved KnollTextiles Grades/Fabrics					Spinneybeck Leather				
A Alignment # Analogy Beacon Bocce Cat's Cradle Chance Common Ground # Commuter Cloth # Crossroad Dristi Foil Rap Heavy Metal Hourglass Mariner Monarch # Overture Prep # Presto # Soliloquy Sonnet Trophy Uni-Form	B continued Forza Gala II Grande Grandview Holbrook Journey Knoll Felt Knoll Hopsack Little Devil Ludlow Keaton Mini Stitch # Nonchalant CR Odeon Paradigm Petal Pusher Radiance Ransom Roam Rush Hour Prairie Prim # Soiree Spark # Spree Summit Sutton Synth Utmost Venue Versa Vinyl Westwood Wide Angle # Zephyr Zipline	C Atlas Axiom Baxter Cairo Charm # Circa Classic Boucle Dahlia CR Decade Dune Durand Earthwork # Echo Empire Stripe Emmesh # Entourage Fable CR Fibra Greenwich Hudson Hula Hoop # Kaleidoscope CR Kaya CR Kora CR Lagos Legend CR Lore CR Metro Milestone Moto CR # Noble Palisade Panache CR Posh Pullman Quark Roundtrip Sequin CR Sahara Sashiko Sinclair Smart	C continued Star Struck # Stepping Stones Spectator Swing Tight Rope Tilden Tower Grid Treble CR Zari CR Zen Wave D Compass CR Coterie Eclat Weave Hologram # In The Loop Island Kabuki Masquerade Menagerie Origins Woodland Zoom E Cleopatra Ikati Stripe Juno Katazome Kimono Mamba Marquee Meroe Midpoint Nature Walk Sherman Shima Tryst Whip	F Atelier Biscayne Calais Cotton Velvet Cornaro Glider Icon # Intrigue In Stitches Liberty Mod Plaid Rivington Soon Topography Totem Tweed Frieze G Alter Ego Arber Gibson Haze Kamani Melange Modern Tweed Serendipity Spencer Straie Stripe Ultrasuede # Utrillo	H Arno Bavaria Catwalk Constance Firefly #Magritte Stretch Appeal I Aswan Byron Cato Cummings Diamond Days Dynamic Ita Jaipur Knoll Velvet Mepal North Island Olema Piper Rutledge Sandis Tudor Vermeer Zimba	U Vicenza # Volo # V Acqua # Andes # Embossed Tipped España # Hand Tipped # Maremme # Velluto Pelle # W Alaska # Amazon # Antique # Derby # Forte # Lucente # Sabrina # Umbria	X Ducale # Ducale Velour # Y Cervo Copenhagen # Distressed # Gemma Lucca Marissa # Portofino # Riva # Saddle # Torello		
					# Approved for Cal 133 upholstery.				
					Check with your KnollTextiles or Spinneybeck Representative for changes or additions.				

Joe and Linda Ricchio JR® and Ricchio Chair with Upholstered Seat

	description	seat h	arm h	w	d	h	textile fabric, yds.	weight	finish	req. leather sq. ft
<i>Designer(s):</i> Joseph and Linda Ricchio, 1990	44A JR Arm chair, non-stacking 	19"	25 3/4"	23 1/2"	21 3/8"	32 1/8"	0.7	14 lbs.	maple, ebonized	13
		19"	25 3/4"	23 1/2"	21 3/8"	32 1/8"	0.7	14 lbs.	other finishes	13
<i>Award(s):</i> Roscoe, 1991										
	44R Seat basket replacement for 44A and 44A-U 						0.8			14.5

pattern no.	grades A	COM B	C	D	E	F	G	H	I	COL U	V	W	X	Y
44A-(KC, BE)	\$1,340.	\$1,371.	\$1,394.	\$1,424.	\$1,451.	\$1,465.	\$1,499.	\$1,555.	\$1,593.	\$1,742.	\$1,842.	\$2,055.	\$2,097.	\$2,148.
44A-()	1,272.	1,301.	1,326.	1,355.	1,384.	1,395.	1,429.	1,486.	1,526.	1,674.	1,773.	1,985.	2,029.	2,079.
44R-()	241.	270.	295.	327.	350.	366.	400.	450.	497.	640.	742.	955.	998.	1,048.

Order Code	Ordering Information	Construction
<i>Example:</i> 37A-T-BN-K1320/4	<i>Upholstery/COM information:</i> Prices shown include fabric or leather upholstery. Contact your Knoll representative for colors. Only approved KnollTextiles and Spinneybeck leathers may be ordered.	<i>Cal 133 Fire Code</i> #: The JR and Ricchio Chairs comply with the California Technical Bulletin 133 standard if upholstered in Cal 133 approved upholstery. Specify suffix -C at end of pattern number and suffix -133 at end of textile selection. Upcharge applies, see page 19.
37A Arm chair	Customer's Own Material is available pending approval. For approval requirements, processing instructions and ordering information please see page 18.	<i>Frame:</i> Select clear maple hardwood in clear or beech hardwood in stained finish. Dowel and mortise and tenon construction.
T Thick seat		
BN Natural Beech		
K1320/4 Cornaro, Tabasco		
<i>Specify:</i> 1. Pattern number 2. Thick seat option (Ricchio chair only) 3. Finish selection 4. Cal 133 Fire Code option 5. Textile selection	<i>Certified Wood:</i> Chairs manufactured using FSC certified hardwoods are available through Custom Product Development. Extended leadtime and upcharge apply.	<i>Upholstered seat:</i> Injection-molded copolymer plastic seat pan screws into corner blocks of chair frame. Standard seat basket is 1" thick. Thick seat basket option is 2" (Ricchio chair only). Note upcharge above.
<i>Maple:</i> Clear Maple (suffix KC)	<i>KnollStudio wood finishes:</i> KnollStudio wood finishes complement a large variety of KnollStudio veneer and Knoll Office veneer finishes. To select correct complementary finish, please refer to KnollStudio Wood Finish Matrix on page 25. If no complementary standard finish is available, please refer to custom finish policy below.	<i>Upholstered Seat:</i> High density, polyurethane foam used in all upholstered areas. Elastic seat belt suspension.
<i>Beech frame stains:</i> Beech (suffix B311) Bronzed Cherry (suffix B312A) Burnt Walnut (suffix B313) Deep Red Mahogany (suffix B328) Ebonized (suffix BE) Light Cherry (suffix B315) Medium Cherry (suffix B319) Medium Red Mahogany (suffix BR) Medium Walnut (suffix B323) Natural Beech (suffix BN) Warm Brown Walnut (suffix J)	<i>Custom finishes:</i> Complementary finishes to any KnollStudio or Knoll Office wood finish are available at no upcharge. To complement non-Knoll wood veneer or lumber finishes, a one-time, non-negotiable net upcharge of \$662 applies. Re-orders are at no upcharge. Please contact your KnollStudio representative, dealer or Customer Service associate for complete custom finish information and Order Code. Minimum order quantity for any custom finish order: 4 chairs.	<i>Seat Basket Replacement:</i> Upholstered seat sits on chair frame. Screws lock basket in place for easy installation or removal. For seat basket replacements for JR chairs ordered prior to February 2007, specify pattern numbers 37R-S. Pricing for 44R will apply.
	<i>Maintenance:</i> See pages 28-29.	<i>Finish:</i> Catalyzed lacquer protective coating. Hand-applied final wax coating.
	<i>Note:</i> The JR and Ricchio Chair are Greenguard certified.	<i>Glides:</i> Recessed plastic glides.
	JR Chair (44A) does not stack.	

Approved KnollTextiles Grades/Fabrics								Spinneybeck Leather		
A Alignment # Analogy Beacon Bocce Cat's Cradle Chance Common Ground # Commuter Cloth # Crossroad Dristi Foil Rap Heavy Metal Hourglass Mariner Monarch # Overture Prep # Presto # Soliloquy Sonnet Trophy Uni-Form	B continued Forza Gala II Grande Grandview Holbrook Journey Knoll Felt Knoll Hopsack Little Devil Ludlow Keaton Mini Stitch # Nonchalant CR Odeon Paradigm Petal Pusher Radiance Ransom Roam Rush Hour Prairie Prim # Spree Summit Sutton Synth Utmost Venue Versa Vinyl Westwood Wide Angle # Zephyr Zipline	C Atlas Axiom Baxter Cairo Charm # Circa Classic Boucle Dahlia CR Decade Dune Durand Earthwork # Echo Empire Stripe Emmesh # Entourage Fable CR Fibra Greenwich Hudson Hula Hoop # Kaleidoscope CR Kaya CR Kora CR Lagos Legend CR Lore CR Metro Milestone Moto CR # Noble Palisade Panache CR Posh Pullman Quark Roundtrip Sequin CR Sahara Sashiko Sinclair Smart	C continued Star Struck # Stepping Stones Spectator Swing Tight Rope Tilden Tower Grid Treble CR Zari CR Zen Wave	D Compass CR Coterie Eclat Weave Hologram # In The Loop Island Kabuki Masquerade Menagerie Origins Woodland Zoom	E Cleopatra Ikati Stripe Juno Katazome Kimono Mamba Marquee Meroe Midpoint Nature Walk Sherman Shima Tryst Whip	F Atelier Biscayne Calais Cotton Velvet Cornaro Glider Icon # Intrigue In Stitches Liberty Mod Plaid Rivington Soon Topography Totem Tweed Frieze	G Alter Ego Arber Gibson Haze Kamani Melange Modern Tweed Serendipity Spencer Straie Stripe Ultrasede # Utrillo	H Arno Bavaria Catwalk Constance Firefly #Magritte Stretch Appeal I Aswan Byron Canaan Cato Cummings Diamond Days Dynamic Ita Jaipur Knoll Velvet Mepal North Island Olema Piper Rutledge Sandis Tudor Vermeer Walker Worth Zimba	U Vicenza # Volo # V Acqua # Andes # Embossed Tipped España # Hand Tipped # Maremma # Velluto Pelle # W Alaska # Amazon # Antique # Derby # Forte # Lucente # Sabrina # Umbria	X Ducale # Ducale Velour # Y Cervo Copenhagen # Distressed # Gemma Lucca Marissa # Portofino # Riva # Saddle # Torello
								# Approved for Cal 133 upholstery.		
								<i>Check with your KnollTextiles or Spinneybeck Representative for changes or additions.</i>		

Joe and Linda Ricchio

Fully Upholstered Ricchio and JR® Chairs

Designer(s):
Joseph and Linda Ricchio, 1994

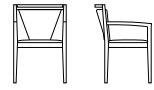

37A-U Ricchio arm chair, uphol. seat and back

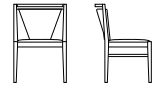

37C-U Ricchio armless chair, uphol. seat and back

description	seat h	arm h	w	d	h	textile fabric yds.	req. leather sq. ft.	weight	finish
37A-U Ricchio arm chair, uphol. seat and back	18 1/2"	26"	21 3/8"	23 3/4"	32 1/4"	1	19	21 lbs.	maple, ebonized
	18 1/2"	26"	21 3/8"	23 3/4"	32 1/4"	1	19	21 lbs.	other finishes
37C-U Ricchio armless chair, uphol. seat and back	18 1/2"		21 3/8"	23 3/4"	32 1/4"	1	19	19 lbs.	maple, ebonized
	18 1/2"		21 3/8"	23 3/4"	32 1/4"	1	19	19 lbs.	other finishes

pattern no.	grades A	COM B	C	D	E	F	G	H	I	COL U	V	W	X	Y
37A-U-(KC, BE)	\$1,810.	\$1,849.	\$1,888.	\$1,926.	\$1,961.	\$1,986.	\$2,029.	\$2,104.	\$2,163.	\$2,545.	\$2,699.	\$2,996.	\$3,062.	\$3,134.
37A-U- ()	1,717.	1,759.	1,796.	1,835.	1,871.	1,896.	1,939.	2,013.	2,074.	2,458.	2,608.	2,907.	2,971.	3,043.
37C-U-(KC, BE)	1,727.	1,768.	1,800.	1,843.	1,879.	1,902.	1,944.	2,023.	2,079.	2,464.	2,612.	2,914.	2,978.	3,048.
37C-U- ()	1,641.	1,680.	1,714.	1,757.	1,793.	1,816.	1,860.	1,938.	1,993.	2,378.	2,528.	2,828.	2,891.	2,964.

Order Code

<i>Example:</i>	37A-U-B319-K1084/2
37A	Ricchio arm chair, upholstered seat and back
U	Upholstered seat and back
B319	Medium Cherry
K1084/2	Harrison, Campbell

Specify:

1. Pattern number
2. Finish selection
3. Cal 133 Fire Code option
4. Textile selection

Maple:

Clear Maple (suffix KC)

Beech frame stains:

- Beech (suffix B311)
- Bronzed Cherry (suffix B312A)
- Burnt Walnut (suffix B313)
- Deep Red Mahogany (suffix B328)
- Ebonized (suffix BE)
- Light Cherry (suffix B315)
- Medium Cherry (suffix B319)
- Medium Red Mahogany (suffix BR)
- Medium Walnut (suffix B323)
- Natural Beech (suffix BN)
- Warm Brown Walnut (suffix J)

Ordering Information

Upholstery/COM information:

Prices shown include fabric or leather upholstery. Contact your Knoll representative for colors. Only approved KnollTextiles and Spinneybeck leathers may be ordered.

Customer's Own Material is available pending approval. For approval requirements, processing instructions and ordering information please see page 18.

KnollStudio wood finishes:

KnollStudio wood finishes complement a large variety of KnollStudio veneer and Knoll Office veneer finishes. To select correct complementary finish, please refer to KnollStudio Wood Finish Matrix on page 25. If no complementary standard finish is available, please refer to custom finish policy below.

Custom finishes:

Complementary finishes to any KnollStudio or Knoll Office wood finish are available at no upcharge. To complement non-Knoll wood veneer or lumber finishes, a one-time, non-negotiable net upcharge of \$662 applies. Re-orders are at no upcharge. Please contact your KnollStudio representative, dealer or Customer Service associate for complete custom finish information and Order Code. Minimum order quantity for any custom finish order: 4 chairs.

Cal 133 Fire Code #:

The Fully Upholstered Ricchio Chairs comply with the California Technical Bulletin 133 standard if upholstered in Cal 133 approved upholstery. Specify suffix -C at end of pattern number and suffix -133 at end of textile selection. Upcharge applies, see page 19.

Certified Wood:

Chairs manufactured using FSC certified hardwoods are available through Custom Product Development. Extended leadtime and upcharge apply.

Maintenance:

See pages 28-29

Note:

The Fully Upholstered Ricchio and JR Chairs are Greenguard certified.

Construction

Frame:

Select clear maple hardwood in clear or beech hardwood in stained finish.

Fully upholstered chairs:

Plywood core back panel bolted to frame for added strength. Optional arm panels have plywood core bolted to frame. Injection-molded plastic seat pan. High density, polyurethane foam used in all upholstered areas. JR fully upholstered chair does not stack.

Finish:

Catalyzed lacquer protective coating. Hand-applied final wax coating.

Glides:

Recessed plastic glides.

Approved KnollTextiles Grades/Fabrics

A

Alignment #
Beacon
Bocce
Cat's Cradle
Chance
Common Ground #
Commuter Cloth #
Crossroad
Delite
Dristi
Foil Rap
Heavy Metal
Hourglass
Mariner
Overture
Prep #
Presto #
Soliloquy
Sonnet
Trophy
Uni-Form

B

Abacus #
Argyle
Backdrop
Belize
Bistro #
Boundary #
Calypso
Cameo
Chroma #
Chronicle
Close Knit
Digital Tape
Diva
Fast Forward
Ferry
Forza

B continued

Gala II
Grande
Grandview
Helios
Holbrook
Journey
Keaton
Knoll Felt
Knoll Hopsack
Little Devil
Mini Stitch #
Melody
Paradigm
Petal Pusher
Prairie
Prim #
Radiance
Ransom
Roam
Rush Hour
Spark #
Spree
Summit
Sutton
Synth
Tabloid
Tinge
Utmost
Venue
Versa
Vinyl
Westwood
Wide Angle #
Zipline

C

Atlas
Axiom
Baxter
Cairo
Charm
Circa
Classic Boucle
Decade
Durand
Earthwork #
Echo
Empire Stripe
Enmesh #
Entourage
Fibra
Greenwich
Hudson
Hula Hoop
Kaleidoscope CR
Kora CR
Lagos
Legend CR
Lore CR
Magnolia
Metro
Milestone
Moto CR #
Noble
Palisade
Panache CR
Pullman
Quark

C continued

Roundtrip
Sequin CR
Sinclair
Smart
Spot On
Star Struck
Stepping Stones
Spectator
Swing
Tight Rope
Tilden
Tower Grid
Treble CR
Wit
Zari CR
Compass CR
Coterie
Eclat Weave
Hologram #
In The Loop
Island
Masquerade
Menagerie
Origins
Woodland
Zoom

E

Aegean
Cleo
Highland
Ikat Stripe
Juno
Katazome
Mamba
Marquee
Meroe
Midpoint
Nature Walk
Sherman
Shima
Tryst
Whip

F

Atelier
Biscayne
Calais Cotton
Velvet
Cornaro
Glider
Icon
Intrigue
In Stitches
Liberty
Mod Plaid
Rivington
Soon
Topography
Totem
Tweed Frieze

G

Alter Ego
Arber
Gibson

G continued

Haze
Kamani
Melange
Modern Tweed
Petite Floral
Serendipity
Spencer
Straie Stripe
Ultrasuede #
Utrillo
Arno
Bavaria
Catwalk
Constance
Firefly
Magritte
Stretch Appeal

I

Aswan
Byron
Cato
Cummings
Diamond Days
Dynamic
Ita
Jaipur
Knoll Velvet
Limani
North Island
Olema
Piper
Rutledge
Tudor
Vermeer
Zimba

Spinneybeck Leather

U

Vicenza #
Volo #
Acqua #
Andes #
Embossed Tipped
España #
Velluto Pelle #

W

Alaska #
Amazon #
Antique #

W continued

Forte #
Lucente
Sabrina #
Ducale Velour #
Cervo
Copenhagen #
Distressed #
Gemma
Marissa #
Riva #
Torello

Approved for Cal 133 upholstery.

Check with KnollTextiles or Spinneybeck Representative for changes or additions.

Joe and Linda Ricchio

Fully Upholstered Ricchio and JR® Chairs

Designer(s):
Joseph and Linda Ricchio, 1994

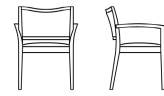

description	height, seat	height, arm	w	d	h	textile fabric yds.	reg. leather sq. ft.	weight	finish
	19"	26"	24"	22"	32"	1	18	15 lbs.	other finishes

pattern no.	grade										COL				
	A	B	C	D	E	F	G	H	I	U	V	W	X	Y	
44AU-(KC, BE)	\$1,757.	\$1,787.	\$1,816.	\$1,850.	\$1,876.	\$1,895.	\$1,928.	\$1,991.	\$2,034.	\$2,180.	\$2,290.	\$2,516.	\$2,563.	\$2,619.	
44AU-()	1,584.	1,615.	1,644.	1,676.	1,704.	1,720.	1,753.	1,816.	1,862.	2,005.	2,118.	2,344.	2,388.	2,444.	

Order Code	Ordering Information	Construction								
<p><i>Example:</i> 37A-U-B319-K1084/2</p> <table border="1"> <tr> <td>37A</td> <td>Ricchio arm chair, upholstered seat and back</td> </tr> <tr> <td>U</td> <td>Upholstered seat and back</td> </tr> <tr> <td>B319</td> <td>Medium Cherry</td> </tr> <tr> <td>K1084/2</td> <td>Harrison, Campbell</td> </tr> </table>	37A	Ricchio arm chair, upholstered seat and back	U	Upholstered seat and back	B319	Medium Cherry	K1084/2	Harrison, Campbell	<p>Upholstery/COM information: Prices shown include fabric or leather upholstery. Contact your Knoll representative for colors. Only approved KnollTextiles and Spinneybeck leathers may be ordered.</p> <p>Customer's Own Material is available pending approval. For approval requirements, processing instructions and ordering information please see page 18.</p> <p>KnollStudio wood finishes: KnollStudio wood finishes complement a large variety of KnollStudio veneer and Knoll Office veneer finishes. To select correct complementary finish, please refer to KnollStudio Wood Finish Matrix on page 25. If no complementary standard finish is available, please refer to custom finish policy below.</p> <p>Custom finishes: Complementary finishes to any KnollStudio or Knoll Office wood finish are available at no upcharge. To complement non-Knoll wood veneer or lumber finishes, a one-time, non-negotiable net upcharge of \$662 applies. Re-orders are at no upcharge. Please contact your KnollStudio representative, dealer or Customer Service associate for complete custom finish information and Order Code. Minimum order quantity for any custom finish order: 4 chairs.</p>	<p>Cal 133 Fire Code #: The Fully Upholstered Ricchio Chairs comply with the California Technical Bulletin 133 standard if upholstered in Cal 133 approved upholstery. Specify suffix -C at end of pattern number and suffix -133 at end of textile selection. Upcharge applies, see page 19.</p> <p>Certified Wood: Chairs manufactured using FSC certified hardwoods are available through Custom Product Development. Extended leadtime and upcharge apply.</p> <p>Maintenance: See pages 28-29</p> <p>Note: The Fully Upholstered Ricchio and JR Chairs are Greenguard certified.</p>
37A	Ricchio arm chair, upholstered seat and back									
U	Upholstered seat and back									
B319	Medium Cherry									
K1084/2	Harrison, Campbell									
<p>Specify:</p> <ol style="list-style-type: none"> 1. Pattern number 2. Finish selection 3. Cal 133 Fire Code option 4. Textile selection <p>Maple: Clear Maple (suffix KC)</p> <p>Beech frame stains: Beech (suffix B311) Bronzed Cherry (suffix B312A) Burnt Walnut (suffix B313) Deep Red Mahogany (suffix B328) Ebonized (suffix BE) Light Cherry (suffix B315) Medium Cherry (suffix B319) Medium Red Mahogany (suffix BR) Medium Walnut (suffix B323) Natural Beech (suffix BN) Warm Brown Walnut (suffix J)</p>		<p>Frame: Select clear maple hardwood in clear or beech hardwood in stained finish.</p> <p>Fully upholstered chairs: Plywood core back panel bolted to frame for added strength. Optional arm panels have plywood core bolted to frame. Injection-molded plastic seat pan. High density, polyurethane foam used in all upholstered areas. JR fully upholstered chair does not stack.</p> <p>Finish: Catalyzed lacquer protective coating. Hand-applied final wax coating.</p> <p>Glides: Recessed plastic glides.</p>								

Approved KnollTextiles Grades/Fabrics						Spinneybeck Leather	
A	B	C	C continued	E	G continued	U	W continued
Alignment # Beacon Bocce Cat's Cradle Chance Common Ground # Commuter Cloth # Crossroad Delite Dristi Foil Rap Heavy Metal Hourglass Mariner Overture Prep # Presto # Soliloquy Sonnet Trophy Uni-Form	Gala II Grande Grandview Helios Holbrook Journey Keaton Knoll Felt Knoll Hopsack Little Devil Mini Stitch # Melody Paradigm Petal Pusher Prairie Prim # Radiance Ransom Roam Rush Hour Spark # Spree Summit Sutton Synth Tabloid Tinge Utmost Venue Versa Vinyl Westwood Wide Angle # Zipline	Atlas Axiom Baxter Cairo Charm Circa Classic Boucle Decade Durand Earthwork # Echo Empire Stripe Enmesh # Entourage Fibra Greenwich Hudson Hula Hoop Kaleidoscope CR Kora CR Lagos Legend CR Lore CR Magnolia Metro Milestone Moto CR # Noble Palisade Panache CR Pullman Quark	Roundtrip Sequin CR Sinclair Smart Spot On Star Struck Stepping Stones Spectator Swing Tight Rope Tilden Tower Grid Treble CR Wit Zari CR	Aegean Cleo Highland Ikat Stripe Juno Katazome Mamba Marquee Meroe Midpoint Nature Walk Sherman Shima Tryst Whip	Haze Kamani Melange Modern Tweed Petite Floral Serendipity Spencer Straie Stripe Ultrasuede # Utrillo	Vicenza # Volo # Acqua # Andes # Embossed Tipped España # Velluto Pelle #	Forte # Lucente Sabrina # Ducale Velour # Cervo Copenhagen # Distressed # Gemma Marissa # Riva # Torello
D	B	C	C continued	E	G continued	U	W continued
Compass CR Coterie Eclat Weave Hologram # In The Loop Island Masquerade Menagerie Origins Woodland Zoom	Alaska # Amazon # Antique #	Greenwich Hudson Hula Hoop Kaleidoscope CR Kora CR Lagos Legend CR Lore CR Magnolia Metro Milestone Moto CR # Noble Palisade Panache CR Pullman Quark	Compass CR Coterie Eclat Weave Hologram # In The Loop Island Masquerade Menagerie Origins Woodland Zoom	Atelier Biscayne Calais Cotton Velvet Cornaro Glider Icon Intrigue In Stitches Liberty Mod Plaid Rivington Soon Topography Totem Tweed Frieze	Arno Bavaria Catwalk Constance Firefly Magritte Stretch Appeal	Alaska # Amazon # Antique #	Alaska # Amazon # Antique #
F	H	I	I continued	K	L	M	N
Alter Ego Arber Gibson	Arno Bavaria Catwalk Constance Firefly Magritte Stretch Appeal	Aswan Byron Cato Cummings Diamond Days Dynamic Ita Jaipur Knoll Velvet Limani North Island Olema Piper Rutledge Tudor Vermeer Zimba	Aswan Byron Cato Cummings Diamond Days Dynamic Ita Jaipur Knoll Velvet Limani North Island Olema Piper Rutledge Tudor Vermeer Zimba	Alter Ego Arber Gibson	Arno Bavaria Catwalk Constance Firefly Magritte Stretch Appeal	Alaska # Amazon # Antique #	Alaska # Amazon # Antique #



Approved for Cal 133 upholstery.

Check with KnollTextiles or Spinneybeck Representative for changes or additions.

Jens Risom
Seating
Side Chairs and Stool

Designer(s):
Jens Risom, 1943



description	seat h	w	d	h	reuphol. kit ydg.	weight
666C-WB Side chair with webbed seat and back 	17 3/4"	17 1/4"	18"	30 3/8"		see below
666C-WB-KIT Re-upholstery kit for side chair with webbed back					14.0	
666C Side chair with webbed seat 	17 3/4"	17 1/4"	18"	30 3/8"		see below
666C-KIT Re-upholstery kit for side chair with wood back					9.0	
667Y Sitting stool 	17 1/8"	16 1/2"	15 1/8"	17 1/8"		see below
667Y-KIT Re-upholstery kit for stool					7.0	

pattern no.	maple, ebonized	walnut	teak	webbing kit
666C-WB-(-)(-)	\$1,091.	\$1,361.	\$1,462.	
666C-WB-KIT-(-)				121.
666C-(-)(-)	1,005.	1,305.	n/a	
666C-KIT-(-)				97.
667Y-(-)(-)	649.	680.	n/a	
667Y-KIT-(-)				83.

Order Code

Ordering Information

<i>Example:</i> 666C-WB-KC-RD
666C-WB Risom side chair with webbed seat and back
KC Clear maple
RD Red cotton webbing

Frame finishes:
Clear maple (suffix KC)
Ebonized maple (suffix KE)
Light walnut (suffix LWT)
Teak (suffix K)

Cotton/nylon webbing colors:
Blueberry (suffix BU)
Eucalyptus (suffix EU)
Licorice (suffix LC)
Nutmeg (suffix NM)
Squash (suffix SH)
Tomato (suffix TO)

Re-upholstery kit:
Webbing straps in one length to re-upholster existing chairs. Must be reupholstered by a professional upholsterer.

Note:
The Risom lounge chairs are part of a collection. Please refer to the Risom side chairs on page 234 and tables on page 360.

Cotton webbing colors:
Aubergine (suffix AU)
Black (suffix BL)
Dark grey (suffix DG)
Flax (suffix FL)
Forest green (suffix FG)
Khaki (suffix KH)
Maize (suffix MZ)
Navy (suffix NA)
Red (suffix RD)
Steel blue (suffix SB)

Sunbrella® webbing colors:
Antique Beige (suffix AB)
Carbon (suffix CB)
Charcoal (suffix CH)
Fern (suffix FR)
Navy (suffix NV)
Ochre (suffix OC)

Note:
The Risom side chairs are Greenguard certified.

Maintenance:
See pages 28-29.

*Teak frames with cotton or nylon webbing are for indoor use only.

Construction

Frame:
Select maple or walnut hardwood with clear finish. Ebonized finish is stained maple hardwood. Mortise and tenon construction. Teak frame is solid teak lumber with an oiled finish.

Upholstery:
Cotton webbing is 100% natural cotton. Nylon webbing straps are 60% nylon, 40% cotton with water repellent finish. Cotton and Nylon webbing are CAL133 approved.

Weight:
Side Chair with webbed seat and back in Maple or Ebonized finishes weighs 12 lbs. Walnut finish weighs 11 lbs. Teak finish weighs 10 lbs. Side Chair with webbed seat in Maple or Ebonized finishes weighs 12lbs. Walnut finish weighs 11lbs. Sitting stool in Maple or Ebonized finishes weighs 7 lbs. Walnut finish weighs 7 lbs.

Note:
Teak frames include teak stretchers underneath the seat.

Sunbrella® Strap is made with reinforced Sunbrella yarns that are designed to stretch, UV/fade resistant, water repellent, bleach cleanable and stain resistant.

Finish:
Lacquer finish on walnut and maple frames. Oiled finish on teak frame.



Jens Risom

Seating

Child's Side Chairs and Stool

Designer(s):
Jens Risom, 1943



description	seat h	w	d	h	reuphol. kit ydg.	weight
666CS Child's Risom chair, webbed seat only 	13 1/4"	13 1/8"	15 3/8"	23"		6 lbs.
666CS-KIT Re-upholstery kit for Child's side chair with webbed seat					7.0	
666CS-WB Child's Risom chair with webbed seat and back 	13 1/4"	13 1/8"	15 3/8"	23"		6 lbs.
666CS-WB-KIT Re-upholstery kit for Child's side chair with webbed seat and back					9.0	
667YS Child's sitting stool 	13 1/2"	12 3/8"	11 1/2"	13 1/2"		6 lbs.
667YS-KIT Re-upholstery kit for Child's Sitting stool					5.5	



pattern no.	honey beech	webbing kit
666CS-HB-()	\$368.	
666CS-KIT-()		70.
666CS-WB-HB-()	410.	
666CS-WB-KIT-()		102.
667YS-HB-()	267.	
667YS-KIT-()		62.

Order Code	Ordering Information	Construction
<i>Example:</i> 666CS-WB-HB-OR	<i>Frame finishes:</i> Honey Beech (suffix HB)	<i>Frame:</i> Select European Beech hardwood with a toned natural finish. Mortise and tenon construction.
666CS-WB Child's Risom side chair with webbed seat and back	<i>Child's nylon webbing colors:</i> Blue (suffix BC) Green (suffix GC) Orange (suffix OC) Red (suffix RC)	<i>Finish:</i> Toned catalyzed lacquer finish
HB Honey Beech		<i>Child's Risom Chairs:</i> Child's Risom Chairs are 75% scale of standard risom chair. Child's size chairs are only available in Honey Beech (HB) finish and approved nylon webbing.
OR Orange nylon webbing	<i>Re-upholstery kit:</i> Webbing straps in one length to re-upholster existing chairs. Must be reupholstered by a professional upholsterer.	<i>Upholstery:</i> Nylon webbing straps are 60% nylon, 40% cotton with water repellent finish. Cotton and Nylon webbing are CAL133 approved.
Note: The Child's Risom side chairs are part of a collection. Please refer to the Child's Risom Amoeba table on page 362.	<i>Maintenance:</i> See pages 28-29.	<i>Note:</i> The Child's Risom chair and stool are compliant to the Consumer Product Safety Improvement Act of 2008 for Children's Products, 16 C.F.R. 1303, CPSIA Title 1 Section 101 for Total Lead in Substrates and Surface Coatings.
<i>Specify:</i> 1. Pattern number 2. Frame finish 3. Webbing color selection		

Jens Risom
Seating
Lounge Chairs

Designer(s):
Jens Risom, 1943



description	seat h	arm h	w	d	h	reuphol. kit ydg.	weight
654LA Arm lounge chair 	16"	22"	23 3/4"	27 1/4"	30 1/4"		see below
654LC Armless lounge chair 	16"		20"	27 1/2"	30 1/4"		see below
654L-KIT Re-upholstery kit for arm and armless lounge chair						25	
655LO Ottoman 			19"	17 3/4"	16"		see below
655LO-KIT Re-upholstery kit for ottoman						11	

pattern no.	maple, ebonized	walnut	teak	webbing kit
654LA-(-)(-)	\$1,981.	\$2,080.	n/a	
654LC-(-)(-)	1,508.	1,583.	1,791.	
654L-KIT-(-)				163.
655LO-(-)(-)	852.	1,054.	937.	
655LO-KIT-(-)				109.

Order Code

<i>Example:</i>	654LC-KC-RD
654LC	Risom armless lounge chair
KC	Clear maple
RD	Red cotton webbing

Note:
The Risom lounge chairs are part of a collection. Please refer to the Risom side chairs on page 234 and tables on page 360.

- Specify:
1. Pattern number
 2. Frame finish
 3. Webbing color selection

Ordering Information

Frame finishes:
Clear maple (suffix KC)
Ebonized maple (suffix KE)
Light walnut (suffix LWT)
Teak (suffix K)

Cotton webbing colors:
Aubergine (suffix AU)
Black (suffix BL)
Dark grey (suffix DG)
Flax (suffix FL)
Forest green (suffix FG)
Khaki (suffix KH)
Maize (suffix MZ)
Navy (suffix NA)
Red (suffix RD)
Steel blue (suffix SB)

Cotton/nylon webbing colors:
Blueberry (suffix BU)
Eucalyptus (suffix EU)
Licorice (suffix LC)
Nutmeg (suffix NM)
Squash (suffix SH)
Tomato (suffix TO)

Sunbrella® webbing colors:
Antique Beige (suffix AB)
Carbon (suffix CB)
Charcoal (suffix CH)
Fern (suffix FR)
Navy (suffix NV)
Ochre (suffix OC)

*Teak frames with cotton or nylon webbing are for indoor use only.

Re-upholstery kit:
Webbing straps in one length to re-upholster existing chairs. Must be reupholstered by a professional upholsterer.

Note:
The Risom Lounge chairs are Greenguard certified.

Maintenance:
See pages 28-29.

Construction

Frame:
Select maple or walnut hardwood with clear finish. Ebonized finish is stained maple hardwood. Mortise and tenon construction. Seat basket of arm lounge chair attaches to arm frame with invisible screws. Teak frame is solid teak lumber with an oiled finish.

Note:
Teak frames include teak stretchers underneath the seat.

Finish:
Lacquer finish on walnut and maple frames. Oiled finish on teak frame.

Upholstery:
Cotton webbing is 100% natural cotton. Nylon webbing straps are 60% nylon, 40% cotton with water repellent finish. Cotton and Nylon webbing are CAL133 approved.



Sunbrella® Strap is made with reinforced Sunbrella yarns that are designed to stretch, UV/fade resistant, water repellent, bleach cleanable and stain resistant.

Weight:
Arm lounge chair in Maple or Ebonized finishes weighs 20 lbs. Walnut finish weighs 17 lbs. Armless lounge chair in Maple and Ebonized finishes weighs 14 lbs. Walnut finish weighs 12 lbs. Teak finish weighs 13 lbs.

Jens Risom
Outdoor Seating
Side Chairs, Lounge and Ottoman

Designer(s):
 Jens Risom, 1943



description	seat h	arm h	w	d	h	reuphol. kit ydg.	weight
666C-WB Side chair with webbed seat and back 	17 3/4"		17 1/4"	18"	30 3/8"		10 lbs.
666C-WB-KIT Re-upholstery kit for side chair with webbed back						14.0	
654LC Armless lounge chair 	16"		20"	27 1/2"	30 1/4"		13 lbs.
654L-KIT Re-upholstery kit for arm and armless lounge chair						25	
655LO Ottoman 			19"	17 3/4"	16"		8 lbs.
655LO-KIT Re-upholstery kit for ottoman						11	

pattern no.	teak
666C-WB-K-(-)	\$1,462.
666C-WB-KIT-(-)	
654LC-K-(-)	1,791.
654L-KIT-(-)	
655LO-K-(-)	937.
655LO-KIT-(-)	

Order Code

<i>Example:</i>	654LC-K-AB
654LC	Risom lounge chair, armless
K	Teak
AB	Sunbrella® Antique Beige

Note:
 The Risom lounge chairs are part of a collection. Please refer to the Risom side chairs on page 234 and tables on page 360.

Specify:

1. Pattern number
2. Frame finish
3. Webbing color selection

Ordering Information

Frame finishes:
 Teak (suffix K)

Sunbrella® webbing colors:
 Antique Beige (suffix AB)
 Carbon (suffix CB)
 Charcoal (suffix CH)
 Fern (suffix FR)
 Navy (suffix NV)
 Ochre (suffix OC)

Re-upholstery kit:
 Webbing straps in one length to re-upholster existing chairs. Must be reupholstered by a professional upholsterer.

Note:
 The Risom Lounge chairs are Greenguard certified.

Maintenance:
 See pages 28-29.

Construction

Teak Frame:
 Solid teak lumber with an oiled finish.

Note:
 Teak will patina over time if left outdoors and will turn a silvery grey color.



Upholstery:
 Sunbrella® Strap is made with reinforced Sunbrella yarns that are designed to stretch, UV/fade resistant, water repellent, bleach cleanable and stain resistant.

Eero Saarinen Tulip Chairs

Designer(s):
Eero Saarinen, 1957

Award(s):
The Museum of Modern Art, New York, USA, 1969; Federal Award for Industrial Design, W. Germany, 1969; Design Center Stuttgart Award, W. Germany, 1962



description	upholstery	seat h	arm h	w	d	h	textile	req.	weight
							fabric yds.	leather sq. ft.	
150A Tulip arm chair 	inner shell	18"	25 1/8"	26"	23 1/4"	32"	2.3	n/a	24 lbs.
	seat cushion	18"	25 1/8"	26"	23 1/4"	32"	0.8	14	18 lbs.
150K Upholstered cushion replacement, arm chair	inner shell	18"	25 1/8"	26"	23 1/4"	32"	2.3	n/a	23 lbs.
	seat cushion	18"	25 1/8"	26"	23 1/4"	32"	0.8	14	18 lbs.
151C Tulip armless chair 	inner shell	18 1/2"		20"	21 1/4"	32"	1.7	n/a	20 lbs.
	seat cushion	18 1/2"		20"	21 1/4"	32"	0.8	14	17 lbs.
	inner shell	18 1/2"		20"	21 1/4"	32"	1.7	n/a	19 lbs.
	seat cushion	18 1/2"		20"	21 1/4"	32"	0.8	14	16 lbs.
151K Upholstered cushion replacement, armless chair	seat cushion						0.8	14	
153Y Stool 		16 1/2"		15 1/2"		18"	0.8	14	10 lbs.

Order Code	Ordering Information	Construction
<i>Example:</i> 150AX-2-U-K2074/6	<i>Swivel or fixed position:</i> Swivel action (suffix S) Fixed position (suffix X)	<i>Maintenance:</i> See pages 28-29.
150AX	Tulip arm chair, fixed position	<i>Base:</i> Cast aluminum. Rilsan coated finish for black and white chairs, platinum chairs consist of a high-resilient polyurethane enamel wet coat with a clear satin finish.
2	White	<i>Note:</i> The signature of Eero Saarinen and the KnollStudio logo are located on the underside of the base.
U	Upholstered inner shell and seat cushion	<i>Shell:</i> Molded fiberglass reinforced plastic bonded finish.
K2074/6	Aegean, Sunshine	<i>Upholstery:</i> Upholstered or unupholstered inner shell, with removable foam cushion (zippered cover and Velcro fastening).
<i>Note:</i> The Saarinen chairs are part of a collection. Please refer to Saarinen lounge seating, executive chairs and tables on pages 244 and 366.	<i>Base and shell finishes:</i> Black (suffix 1) Platinum (suffix PL) (not on fully upholstered chairs) White (suffix 2)	<i>Cal 133 Fire Code:</i> The 513Y Saarinen Stool complies with the California Technical Bulletin 133 standard if upholstered in Cal 133 approved upholstery. Specify suffix -C at end of pattern number and suffix -133 at end of textile selection. Upcharge applies, see page 19.
<i>Specify:</i> 1. Pattern number 2. Swivel or fixed position 3. Finish selection 4. Upholstery option (except stool) 5. Textile selection	<i>Upholstery/COM information:</i> Prices shown include fabric or leather upholstery. Contact your Knoll representative for colors. Only approved KnollTextiles and Spinneybeck leathers may be ordered. Customer's Own Material is available pending approval. For approval requirements, processing instructions and ordering information please see page 18.	

pattern no.	grades	COM	C	D	E	F	G	H	I	COL	V	W	X	Y
150AS-(1,2)U	\$4,820.	\$4,900.	\$4,974.	\$5,062.	\$5,127.	\$5,179.	\$5,262.	\$5,420.	\$5,537.					
150AS-(1,2,PL)K	2,874.	2,898.	2,919.	2,944.	2,965.	2,978.	3,005.	3,050.	3,084.	3,184.	3,269.	3,435.	3,469.	3,508.
150AX-(1,2)U	4,502.	4,583.	4,658.	4,743.	4,812.	4,861.	4,944.	5,105.	5,224.					
150AX-(1,2,PL)K	2,710.	2,730.	2,755.	2,781.	2,799.	2,812.	2,839.	2,885.	2,919.	3,020.	3,102.	3,270.	3,302.	3,345.
150K	568.	593.	613.	638.	654.	669.	692.	736.	769.	938.	1,015.	1,173.	1,205.	1,243.
151CS-(1,2)U	4,065.	4,126.	4,180.	4,242.	4,293.	4,331.	4,391.	4,509.	4,596.					
151CS-(1,2,PL)K	2,476.	2,502.	2,525.	2,548.	2,569.	2,583.	2,608.	2,654.	2,688.	2,832.	2,916.	3,082.	3,116.	3,157.
151CX-(1,2)U	3,925.	3,983.	4,041.	4,103.	4,153.	4,188.	4,252.	4,370.	4,458.					
151CX-(1,2,PL)K	2,240.	2,265.	2,285.	2,311.	2,331.	2,345.	2,369.	2,417.	2,451.	2,701.	2,785.	2,950.	2,987.	3,025.
151K	568.	593.	613.	638.	654.	669.	692.	736.	769.	938.	1,015.	1,173.	1,205.	1,243.
153YS-(1, 2, PL)	1,464.	1,486.	1,507.	1,531.	1,549.	1,561.	1,586.	1,631.	1,664.	1,759.	1,834.	1,993.	2,026.	2,063.



Approved KnollTextiles Grades/Fabrics						Spinneybeck Leather										
A Alignment * Beacon Bocce * Cat's Cradle * Common Ground * Commuter Cloth * Crossroad * Delite * Dristi * Hourglass * Mariner * Metaphor Monarch Overture * Prep Presto (n/a on stool) Soliloquy * Sonnet * Trophy * Uni-Form	B Keaton * Knoll Felt * Knoll Hopsack * Ludlow * Melody Mini Stitch * Paradigm * Petal Pusher * Pop * Prairie * Prim * Radiance * Ransom * Roam * Rush Hour * Spark * Spinoff Nuance * Spree * Starry Night * Summit Sutton * Synth * Tabloid * Tinge * Venue * Versa * Vinyl Westwood * Wide Angle * Yeni * Zipline *	C Atlas * Autobahn Axiom * Baxter * Cairo * Charm * Circa * Classic Boucle * Dahlia * Dune * Durand * Earthwork * Echo * Empire Stripe Emmesh * Entourage * Essence * Fable CR * Fibra * Greenwich * Hudson Island * Kabuki Kora CR Lagos * Legend CR Lore CR Magnolia Metro Milestone * Moto CR * Noble * Panache CR * Pullman * Quark * Roundtrip * Sahara * Sequin CR *	C continued Sinclair * Smart * Spectator * Spot On * Star Struck * Stepping Stones Swing * Tight Rope * Tilden * Tower Grid * Transition * Treble CR * Wit * Zari CR *	D Compass CR Coterie * Eclat Weave * Hologram Island * Kabuki Masquerade Menagerie * Origins * Satellite Satin Chisel Woodland * Zoom	E Aegean * Cleo * Demure * Highland * Ikat Stripe * Juno *	E continued Katazome * Luberon * Mamba * Marquee * Meroe * Midpoint * Nature Walk Sherman * Shima * Vatera Whip *	F Atelier * Biscayne * Calais Cotton Velvet Cornaro * Eclipse * Glider * Icon * Intrigue * In Stitches * Liberty * Mod Plaid * Rivington * Soon Topography * Totem * Tweed Frieze *	G Alter Ego Arber * Gibson * Haze * Kamani	G continued Little Devil * Melange * Modern Tweed Petite Floral * Serendipity * Stepping Stones Ultrasuede * Utrillo *	H Arno * Bavaria * Catwalk Constance * Firefly * Magritte * Stretch Appeal *	I Aswan * Bryon * Cato * Diamond Days * Dynamic * Ita * Jaipur * Knoll Velvet * Limani * North Island * Olema Piper * Ravello * Rutledge * Sandis * Tudor * Vermeer * Zimba *	U Vicenza Volo	V Acqua Andes Embossed Tipped España Hand Tipped Velluto Pelle	W Alaska Amazon Antique Derby Forte Lucente Sabrina Umbria	X Ducale Ducale Velour	Y Cervo Copenhagen Distressed Gemma Lucca Marissa Portofino Riva Torello

* Approved for fully upholstered versions.
 ‡ Approved for Cal133 upholstery.
 Check with your KnollTextiles or Spinneybeck Representative for changes or additions.

Eero Saarinen Executive Arm Chairs

Designer(s):
Eero Saarinen, 1950



description	seat h,		w	d	h,		textile fabric yds.	req. leather sq. ft.	weight	type
	min	max			h, min	h, max				
71A-T5G-H Executive arm chair with pneumatic seat height adjustment	16 1/2"	21 3/4"	26"	24 3/4"	31"	36 1/4"	2.9	47	34 lbs.	
										
Executive arm chair with pneumatic seat height adjustment, contrast leather welt option	16 1/2"	21 3/4"	26"	24 3/4"	31"	36 1/4"	2.9	47	34 lbs.	uphol.
								6.25		welt
71A Executive arm chair with tubular legs and glides	18"		26"	24 3/4"	31 1/2"		2.9	47	19 lbs.	
										
Executive arm chair with tubular legs and glides, contrast leather welt option	18"		26"	24 3/4"	31 1/2"		2.9	47	19 lbs.	uphol.
								6.25		welt
R Optional soft wheel casters (change -H to -R)										
3 Optional black top caps (add -3 after 71A, not available for 71A-PC)										

pattern no.	upcharge	grades A	COM B	C	D	E	F	G	H	I	COL					V	W	X	Y
71A-T5G-(-)(-)		\$3,188.	\$3,272.	\$3,353.	\$3,443.	\$3,516.	\$3,569.	\$3,661.	\$3,829.	\$3,957.	\$4,975.	\$5,254.	\$5,814.	\$5,931.	\$6,065.				
71A-T5G-(-)LT-(-)(-)		3,188.	3,272.	3,353.	3,443.	3,516.	3,569.	3,661.	3,829.	3,957.	4,975.	5,254.	5,814.	5,931.	6,065.				
upchg, welt											243.	277.	344.	358.	375.				
71A-(BL,C)-(-)		2,352.	2,436.	2,521.	2,608.	2,682.	2,734.	2,826.	2,994.	3,121.	4,138.	4,413.	4,972.	5,089.	5,226.				
71A-(BL,C)-LT-(-)(-)		2,352.	2,436.	2,521.	2,608.	2,682.	2,734.	2,826.	2,994.	3,121.	4,138.	4,413.	4,972.	5,089.	5,226.				
upchg, welt											243.	277.	344.	358.	375.				
R	n/c																		
3	97.																		

Order Code	Ordering Information
<i>Example:</i> 71A-3-T5G-R-ES8080	<i>Wood Leg Finishes:</i>
71A Open back arm chair	Ebonized Walnut (suffix D)
3 Black top caps	Light Oak (suffix LO)
T5G Advanced height adjustment, swivel/tilt	Light Walnut (suffix LWA)
R Soft wheel casters	Pearwood (suffix P)
ES8080 Espana, Serpentina	Reff Dark Cherry (suffix V314)

Note:
The Saarinen executive chairs are part of a collection. Please refer to Saarinen side chairs, lounge chairs and tables on beginning on pages 242 and 366.

- Specify:
1. Pattern number
 2. Black top cap option (swivel base only)
 3. Caster type (swivel base only)
 4. Cal 133 fire code option
 5. Split upholstery option (add S)
 6. Textile selection

Ordering Information
<i>Tubular Leg Finishes:</i>
Black (BL)
Polished Chrome (suffix C)

Caster option:
Hard wheel casters standard. For soft wheel casters, change -H in pattern number to -R. No glide option on swivel models.

Split upholstery option:
The seat and back of the Saarinen Executive Chair can be specified in split upholstery. Indicate S before selected seat upholstery, followed by selected back upholstery. The price equals the price of the higher upholstery grade.

COM split fabric requirements:
Back upholstery: 2.25 yards
Seat upholstery: 1.25 yards

COL split leather requirements:
Back upholstery: 40 square feet
Seat upholstery: 23 square feet

Construction

Upholstery/COM information:
Prices shown include fabric or leather upholstery. Contact your Knoll representative for colors. Only approved KnollTextiles and Spinneybeck leathers may be ordered.

Customer's Own Material is available pending approval. For approval requirements, processing instructions and ordering information please see page 18.

Cal 133 Fire Code #:
The Saarinen Executive Chairs comply with the California Technical Bulletin 133 standard if upholstered in Cal 133 approved upholstery. Specify suffix -C at end of pattern number and suffix -133 at end of textile selection. Upcharge applies, see page 19.

Maintenance:
See pages 28-29.

Note:
The Saarinen Executive Arm Chair is Greenguard certified.

Frame:
Molded reinforced polyurethane shell. Contoured plywood seat form.

Upholstery:
Urethane foam cushion. Welt detail along arm, back and top of seat is available as a self welt (same material) or as a contrasting leather welt. Please specify pattern number with LT suffix, for contrasting welt, and add appropriate leather upcharge for total list price of the piece. Leather welt option is available on both textile and leather upholstery.

Swivel base:
Five-star steel base in protective black epoxy finish. Stainless steel or optional black epoxy top caps.

Steel leg base:
Four legs in seamless tubular steel with polished chrome or matte black powder coat.

Approved KnollTextiles Grades/Fabrics

Wood leg base:
Solid steam bent oak with a clear or stained finish. Finish is complementary match to Saarinen, Florence Knoll and Platner low tables.

Casters:
2" twin wheel hard casters for use on carpeted floors. Wheel and housing components in black textured plastic. Optional soft casters for use on wood and other resilient flooring (black with grey housing).

Glides:
Molded nylon disk in stamped steel shroud.

A Beacon Common Ground # Commuter Cloth # Crossroad Delite Dristi Hourglass Mariner Presto Sonnet Trophy	B continued Sutton Synth Tinge Venue Vinyl Westwood Wide Angle	D Hologram Woodland Zoom	E Aegean Highland Mamba Sherman	C Axiom Classic Boucle Durand Echo Entourage Essence Hula Hoop Lagos Metro Palisade Pullman Quark Sequin CR Sinclair Smart Stepping Stones Swing Tilden	F Atelier Biscayne Cornaro Intrigue In Stitches Liberty Rivington Tweed Frieze	G Alter Ego Brugge	G continued Haze Melange Modern Tweed Petite Floral Serendipity Ultrasuede Utrillo	H Arno Bavaria Catwalk Magritte	I Aswan Cato Diamond Days Dynamic Ita Knoll Velvet Limani North Island Rutledge Tudor Zimba	U Vicenza # Volo #	V Acqua # Andes # España # Velluto Pelle #	X Ducale # Ducale Velour #	Y Cervo # Copenhagen # Distressed # Marissa # Riva #
---	--	---------------------------------------	---	---	--	------------------------------	--	---	--	------------------------------	--	--------------------------------------	---

Approved for Cal 133 upholstery.

Check with your KnollTextiles or Spinneybeck Representative for changes or additions.

Eero Saarinen

Executive Arm Chairs

Designer(s):
Eero Saarinen, 1950



description	seat h,		w	d	h, min		textile fabric yds.	req. leather sq. ft.	weight	type
	min	max			h, min	h, max				
71A-W Executive arm chair with wood legs and glides	18"	26"	24 3/4"	31 1/2"	2.9	47	18 lbs.			
Executive arm chair with wood legs and glides, contrast leather welt option	18"	26"	24 3/4"	31 1/2"	2.9	47	18 lbs.	uphol.		
						6.25		welt		



pattern no.	upcharge	grades A	COM B	C	D	E	F	G	H	I	COL					V	W	X	Y
71A-W(-)-()		\$2,754.	\$2,841.	\$2,924.	\$3,018.	\$3,094.	\$3,148.	\$3,242.	\$3,416.	\$3,546.	\$4,562.	\$4,851.	\$5,430.	\$5,548.	\$5,690.				
71A-W(-)-LT(-)-()		2,754.	2,841.	2,924.	3,018.	3,094.	3,148.	3,242.	3,416.	3,546.	4,562.	4,851.	5,430.	5,548.	5,690.				
upchg, welt											243.	277.	344.	358.	375.				

Order Code

<i>Example:</i>	71A-3-T5G-R-ES8080
71A	Open back arm chair
3	Black top caps
T5G	Advanced height adjustment, swivel/tilt
R	Soft wheel casters
ES8080	Espana, Serpentina

Note:
The Saarinen executive chairs are part of a collection. Please refer to Saarinen side chairs, lounge chairs and tables on beginning on pages 242 and 366.

Specify:

1. Pattern number
2. Black top cap option (swivel base only)
3. Caster type (swivel base only)
4. Cal 133 fire code option
5. Split upholstery option (add S)
6. Textile selection

Ordering Information

Wood Leg Finishes:
Ebonized Walnut (suffix D)
Light Oak (suffix LO)
Light Walnut (suffix LWA)
Pearwood (suffix P)
Reff Dark Cherry (suffix V314)

Tubular Leg Finishes:
Black (BL)
Polished Chrome (suffix C)

Caster option:
Hard wheel casters standard. For soft wheel casters, change -H in pattern number to -R. No glide option on swivel models.

Split upholstery option:
The seat and back of the Saarinen Executive Chair can be specified in split upholstery. Indicate S before selected seat upholstery, followed by selected back upholstery. The price equals the price of the higher upholstery grade.

COM split fabric requirements:
Back upholstery: 2.25 yards
Seat upholstery: 1.25 yards

COL split leather requirements:
Back upholstery: 40 square feet
Seat upholstery: 23 square feet

Construction

Frame:
Molded reinforced polyurethane shell. Contoured plywood seat form.

Upholstery:
Urethane foam cushion. Welt detail along arm, back and top of seat is available as a self welt (same material) or as a contrasting leather welt. Please specify pattern number with LT suffix, for contrasting welt, and add appropriate leather upcharge for total list price of the piece. Leather welt option is available on both textile and leather upholstery.

Swivel base:
Five-star steel base in protective black epoxy finish. Stainless steel or optional black epoxy top caps.

Steel leg base:
Four legs in seamless tubular steel with polished chrome or matte black powder coat.

Approved KnollTextiles Grades/Fabrics

Wood leg base:
Solid steam bent oak with a clear or stained finish. Finish is complementary match to Saarinen, Florence Knoll and Platner low tables.

Casters:
2" twin wheel hard casters for use on carpeted floors. Wheel and housing components in black textured plastic. Optional soft casters for use on wood and other resilient flooring (black with grey housing).

Glides:
Molded nylon disk in stamped steel shroud.

A Beacon Common Ground [‡] Commuter Cloth [‡] Crossroad Delite Dristi Hourglass Mariner Presto Sonnet Trophy	B continued Sutton Synth Tinge Venue Vinyl Westwood Wide Angle	D Hologram Woodland Zoom	E Aegean Highland Mamba Sherman	F Atelier Biscayne Cornaro Intrigue In Stitches Liberty Rivington Tweed Frieze	G Alter Ego Arber
B Abacus Boundary Cameo Diva Ferry Grande Journey Keaton Knoll Felt [‡] Knoll Hopsack [‡] Little Devil Melody Petal Pusher Prairie Rush Hour	C Axiom Classic Boucle Durand Echo Entourage Essence Hula Hoop Lagos Metro Palisade Pullman Quark Sequin CR Sinclair Smart Stepping Stones Swing Tilden	G continued Haze Melange Modern Tweed Petite Floral Serendipity Ultrasuede Utrillo	H Arno Bavaria Catwalk Magritte	I Aswan Cato Diamond Days Dynamic Ita Knoll Velvet Limani North Island Rutledge Tudor Vermeer Zimba	

Spinneybeck Leather



U Vicenza [‡] Volo [‡]	X Ducale [‡] Ducale Velour [‡]
V Acqua [‡] Andes [‡] Embossed Tipped [‡] España [‡] Velluto Pelle [‡]	Y Cervo [‡] Copenhagen [‡] Distressed [‡] Marissa [‡] Riva [‡]
W Alaska [‡] Amazon [‡] Antique [‡] Derby [‡] Forte [‡] Lucente [‡] Sabrina [‡]	

[‡] Approved for Cal 133 upholstery.

Check with your KnollTextiles or Spinneybeck Representative for changes or additions.

Eero Saarinen

Executive Armless Chairs

description	seat h,	seat h,	w	d	h, min	h, max	textile	req.	weight	
	min	max					fabric	leather		
	yds.	sq. ft.								
<i>Designer(s):</i> Eero Saarinen, 1946	72C-T5G-H Executive armless chair with pneumatic seat height adjustment	14 1/2"	19 3/4"	22 1/2"	24"	31"	36 1/4"	2.0	35	29 lbs.
	72C Executive armless chair with tubular legs and glides	18 3/4"		22 1/2"	20 1/2"	31 1/2"		2.0	35	14 lbs.
	3 Optional black top caps (add -3 after 72C, not available for 72C-PC)									
	R Optional soft wheel casters (change -H to -R)									





Order Code	Ordering Information
<i>Example:</i> 72C-C-S-CD70-AL5008	<i>Caster option:</i> Hard wheel casters standard. For soft wheel casters, change -H to -R. No glide option on swivel models.
72C Open back chair, armless	<i>Cal 133 Fire Code #:</i> The Saarinen Executive Chairs comply with the California Technical Bulletin 133 standard if upholstered in Cal 133 approved upholstery. Specify suffix -C at end of pattern number and suffix -133 at end of textile selection. Upcharge applies, see page 19.
C Polished chrome leg	<i>Maintenance:</i> See pages 28-29.
S Split upholstery option	<i>Note:</i> The Saarinen Executive Armless Chair is Greenguard certified
CD70 seat: Cordovan, Rembrandt Brown	Construction: <i>Frame:</i> Molded reinforced polyurethane shell. Contoured plywood seat form.
AL5008 back: Alaska, Caribou	<i>Plastic Back:</i> Polycarbonate with a wet coat paint in black or white. Note that the seat of the plastic back version is slightly wider than the fully upholstered version.
<i>Note:</i> The Saarinen executive chairs are part of a collection. Please refer to Saarinen side chairs, lounge chairs and tables on beginning on pages 242 and 366.	<i>Upholstery:</i> Urethane foam cushion.
<i>Specify:</i> 1. Pattern number 2. Leg base option 3. Cal 133 fire code option 4. Split upholstery option (add S) 5. Textile selection, seat 6. Textile selection, back	<i>Swivel base:</i> Five-star steel base in protective black epoxy finish. Stainless steel or optional black epoxy top caps.
<i>Wood Leg Finishes:</i> Ebonized Walnut (suffix D) Light Oak (suffix LO) Light Walnut (suffix LWA) Pearwood (suffix P) Reff Dark Cherry (suffix V314)	<i>Steel Leg base:</i> Four legs in seamless tubular steel with polished chrome or matte black powder coat.
<i>Tubular Leg Finishes:</i> Black (suffix BL) Polished Chrome (C)	<i>Wood leg base:</i> Solid steam bent oak with a clear or stained finish. Finish is complementary match to Saarinen, Florence Knoll and Platner low tables
<i>Plastic Back Finishes:</i> Black (suffix 1) White (suffix 2)	<i>Casters:</i> 2" twin wheel hard casters for use on carpeted floors. Wheel and housing components in black textured plastic. Optional soft casters for use on wood and other resilient flooring (black with grey housing).
	<i>Glides:</i> Molded nylon disk in stamped steel shroud.

pattern no.	upcharge	grades	COM	C	D	E	F	G	H	I	COL	V	W	X	Y
		A	B								U				
72C-T5G-H(-)		\$2,283.	\$2,343.	\$2,398.	\$2,461.	\$2,508.	\$2,546.	\$2,608.	\$2,726.	\$2,812.	\$3,360.	\$3,566.	\$3,982.	\$4,070.	\$4,170.
72C-(BL,C)-()		1,577.	1,635.	1,691.	1,752.	1,802.	1,841.	1,901.	2,020.	2,107.	2,621.	2,827.	3,243.	3,329.	3,431.
3	97.														
R	n/c														

Approved KnollTextiles Grades/Fabrics						Spinneybeck Leather								
A Beacon Bocce Cat's Cradle Chance Common Ground # Commuter Cloth # Crossroad Delite Dristi Hourglass Mariner Overture Prep # Presto # Soliloquy Sonnet Trophy	B Abacus # Argyle Belize Bistro # Boundary Calypso Cameo Chroma Chronicle Diva Ferry Forza Gala II Grande Grandview Helios Holbrook Journey Keaton Knoll Felt # Knoll Hopsack # Little Devil Ludlow	C continued Empire Stripe Emmesh # Entourage Essence Fable CR Fibra Greenwich Hudson Hula Hoop Kaleidoscope CR Kora CR Lagos Lore CR Magnolia Metro Milestone Noble Palisade Panache CR Pullman Quark Rountrip Sequin CR Sinclair Smart Spectator Spot On Star Struck # Stepping Stones Swing Tilden Tower Grid Treble CR Zari CR	D Compass CR Coterie Eclat Weave Hologram Island Masquerade Menagerie Origins Woodland Zoom	E Aegean Cleo Demure Highland Juno Katazome Mamba Marquee Nature Walk Sherman Shima Tryst Vatera Whip	F Atelier Biscayne Cornaro Glider Icon Intrigue In Stitches Liberty Mod Plaid Rivington Soon Topography Totem Tweed Frieze	H Arno Bavaria Catwalk Constance Magritte Stretch Appeal	I Aswan Cato Diamond Days Dynamic Ita Jaipur Knoll Velvet Limani North Island Olema Piper Rutledge Tudor Vermeer Zimba	U Vicenza # Volo #	V Acqua # Andes # Embossed Tipped # España # Velluto Pelle #	W Alaska # Amazon # Antique # Forte # Lucente # Sabrina # Umbria	X Ducale # Ducale Velour #	Y Cervo # Copenhagen # Distressed # Gemma Lucca # Marissa # Portofino # Riva #	# Approved for Cal 133 upholstery; approval does not apply to chairs with plastic backs. Check with your KnollTextiles or Spinneybeck Representative for changes or additions.	

Eero Saarinen

Executive Armless Chairs

	description	seat h, min	seat h, max	width	d	h, min	h, max	textile fabric yds.	req. leather sq. ft.	weight
<i>Designer(s):</i> Eero Saarinen, 1946	72C-W Executive armless chair with wood legs and glides	18 3/4"		22 1/2"	20 1/2"	31 1/2"		2.0	35	13 lbs.
										
	72C Executive armless chair with plastic back, tubular legs and glides	18 3/4"		22"	20.5"	31 1/2"		1.3	12	16 lbs.
										



Order Code

<i>Example:</i>	72C-C-S-CD70-AL5008
72C	Open back chair, armless
C	Polished chrome leg
S	Split upholstery option
CD70	seat: Cordovan, Rembrandt Brown
AL5008	back: Alaska, Caribou

Note:
The Saarinen executive chairs are part of a collection. Please refer to Saarinen side chairs, lounge chairs and tables on beginning on pages 242 and 366.

Specify:

1. Pattern number
2. Leg base option
3. Cal 133 fire code option
4. Split upholstery option (add S)
5. Textile selection, seat
6. Textile selection, back

Wood Leg Finishes:

Ebonized Walnut (suffix D)
Light Oak (suffix LO)
Light Walnut (suffix LWA)
Pearwood (suffix P)
Reff Dark Cherry (suffix V314)

Tubular Leg Finishes:

Black (suffix BL)
Polished Chrome (C)

Plastic Back Finishes:

Black (suffix 1)
White (suffix 2)

Ordering Information

Caster option:

Hard wheel casters standard. For soft wheel casters, change -H to -R. No glide option on swivel models.

Split upholstery option:

The seat and back of the Saarinen Executive Chair can be specified in split upholstery. Indicate S before selected seat upholstery, followed by selected back upholstery. The price equals the price of the higher upholstery grade.

COM split fabric requirements:

Back upholstery: 1.5 yards
Seat upholstery: .75 yards

COL split leather requirements:

Back upholstery: 27 square feet
Seat upholstery: 13.5 square feet

Upholstery/COM information:

Prices shown include fabric or leather upholstery. Contact your Knoll representative for colors. Only approved KnollTextiles and Spinneybeck leathers may be ordered. Customer's Own Material is available pending approval. For approval requirements, processing instructions and ordering information please see page 18.

Cal 133 Fire Code:

The Saarinen Executive Chairs comply with the California Technical Bulletin 133 standard if upholstered in Cal 133 approved upholstery. Specify suffix -C at end of pattern number and suffix -133 at end of textile selection. Upcharge applies, see page 19.

Maintenance:

See pages 28-29.

Note:

The Saarinen Executive Armless Chair is Greenguard certified

Construction:

Frame:
Molded reinforced polyurethane shell. Contoured plywood seat form.

Plastic Back:

Polycarbonate with a wet coat paint in black or white. Note that the seat of the plastic back version is slightly wider than the fully upholstered version.

Glides:

Molded nylon disk in stamped steel shroud.

Upholstery:

Urethane foam cushion.

Swivel base:

Five-star steel base in protective black epoxy finish. Stainless steel or optional black epoxy top caps.

Steel Leg base:

Four legs in seamless tubular steel with polished chrome or matte black powder coat.

Wood leg base:

Solid steam bent oak with a clear or stained finish. Finish is complementary match to Saarinen, Florence Knoll and Platner low tables

Casters:

2" twin wheel hard casters for use on carpeted floors. Wheel and housing components in black textured plastic. Optional soft casters for use on wood and other resilient flooring (black with grey housing).

Glides:

Molded nylon disk in stamped steel shroud.

pattern no.	upcharge	grades A	COM B	C	D	E	F	G	H	I	COL U	V	W	X	Y
72C-W(-)(-)		\$2,011.	\$2,071.	\$2,129.	\$2,193.	\$2,244.	\$2,283.	\$2,347.	\$2,469.	\$2,560.	\$3,080.	\$3,293.	\$3,723.	\$3,814.	\$3,919.
72C-(BL,C)-(1,2)-(-)		1,097.	1,136.	1,172.	1,212.	1,244.	1,266.	1,309.	1,385.	1,442.	1,358.	1,429.	1,571.	1,602.	1,636.

Approved KnollTextiles Grades/Fabrics

A Beacon Bocce Cat's Cradle Chance Common Ground Commuter Cloth Crossroad Delite Dristi Hourglass Mariner Overture Prep Presto Soliloquy Sonnet Trophy	B Abacus Argyle Belize Bistro Boundary Calypso Cameo Chroma Chronicle Diva Ferry Forza Gala II Grande Grandview Helios Holbrook Journey Keaton Knoll Felt Knoll Hopsack Little Devil Ludlow	C continued Empire Stripe Emmesh Entourage Essence Fable CR Fibra Greenwich Hudson Hula Hoop Kaleidoscope CR Kora CR Lagos Lore CR Magnolia Metro Milestone Noble Palisade Panache CR Pullman Quark Rountrip Sequin CR Sinclair Smart Spectator Spot On Star Struck Stepping Stones Swing Tilden Tower Grid Treble CR Zari CR	D Compass CR Coterie Eclat Weave Hologram Island Masquerade Menagerie Origins Woodland Zoom	E Aegean Cleo Demure Highland Juno Katazome Mamba Marquee Nature Walk Sherman Shima Tryst Vatera Whip	F Atelier Biscayne Cornaro Glider Icon Intrigue In Stitches Liberty Mod Plaid Rivington Soon Topography Totem Tweed Frieze	G Alter Ego Arber Gibson Haze Kamani Melange Modern Tweed Petite Floral Serendipity Spencer Straie Stripe Ultrasuede Utrillo	H Arno Bavaria Catwalk Constance Magritte Stretch Appeal	I Aswan Cato Diamond Days Dynamic Ita Jaipur Knoll Velvet Limani North Island Olema Piper Rutledge Tudor Vermeer Zimba	U Vicenza Volo	V Acqua Andes Embossed Tipped España Velluto Pelle	W Alaska Amazon Antique Forte Lucente Sabrina Umbria	X Ducale Ducale Velour	Y Cervo Copenhagen Distressed Gemma Lucca Marissa Portofino Riva
--	---	---	--	--	---	--	---	--	-----------------------------	--	--	-------------------------------------	---

Spinneybeck Leather

Approved for Cal 133 upholstery; approval does not apply to chairs with plastic backs.

Check with your KnollTextiles or Spinneybeck Representative for changes or additions.

Eero Saarinen

Womb Chair, Ottoman and Settee

description	seat h	arm h	w	d	h	textile fabric yds.	req. leather sq. ft.	weight
70L Womb chair	16"	20½"	40"	34"	35½"	7.2	165	36 lbs.
74Y Ottoman			25½"	20"	16"	2.1	55	13 lbs.

Designer(s):
Eero Saarinen, 1948



Order Code

<i>Example:</i>	70LM-BL-K530/4
70LM	Medium womb chair
BL	Black base
K530/4	Lyonese Velvet, Cognac

Note:
The Womb chair and ottoman and Womb Settee are part of a collection. Please refer to Saarinen side and executive chairs and tables on pages 242 and 366.

Specify:

1. Pattern number/size
2. Base finish selection
3. Cal 133 option
4. Split upholstery option (add S)
5. Textile selection

Ordering Information

Base finishes:
Black (suffix BL)
☞ Polished Chrome (suffix C)

Upholstery/COM information:
Prices shown include fabric or leather upholstery. Contact your Knoll representative for colors. Only approved KnollTextiles and Spinneybeck leathers may be ordered.

Customer's Own Material is available pending approval. For approval requirements, processing instructions and ordering information please see page 18.

☞ *KnollStudio 20-day Program:*
The standard Womb chair and ottoman are available in a chrome finish on the 20-day program upholstered with in-stock KnollTextile. For more information, please consult pages 30-33.

Split upholstery option:
The surround and cushions of the Womb chair and ottoman and Womb settee may be specified with split upholstery. Indicate S before selected surround upholstery, followed by selected cushion upholstery. Price equals the higher upholstery grade.

COM split fabric requirements:
75% Womb chair body: 3.5 yards
75% Womb chair seat/back: 1.25 yards
85% Womb chair body: 3.75 yards
85% Womb chair seat/back: 1.25 yards
85% Ottoman body: 1 yard
85% Ottoman cushion: .75 yards
100% Womb chair body: 5.50 yards
100% Womb chair seat/back: 2 yards
100% Ottoman body: 1 yard
100% Ottoman cushion: 1.25 yards
100% Womb settee body: 9 yards
100% Womb settee seat/back: 2.6 yards

COL split leather requirements:
75% Womb chair body: 90 square ft
75% Womb chair seat/back: 23 square ft
85% Womb chair body: 96 square ft
85% Womb chair seat/back: 25 square ft
85% Ottoman body: 48 square ft
85% Ottoman cushion: 25 square ft
100% Womb chair body: 110 square ft
100% Womb chair seat/back: 40 square ft
100% Ottoman body: 27.5 square ft
100% Ottoman cushion: 27.5 square ft
100% Womb settee body: 275 square ft
100% Womb settee seat/back: 110 square ft

Maintenance:
See pages 28-29.

Cal 133 Fire Code #:
The Womb Chair, Ottoman, and Settee comply with the California Technical Bulletin 133 standard if upholstered in Cal 133 approved upholstery. Specify suffix -C at end of pattern number and suffix -133 at end of textile selection. Upcharge applies, see page 19.

Note:
The Saarinen Womb chair and ottoman and Womb settee are Greenguard certified.

pattern no.	grades	COM	C	D	E	F	G	H	I	COL	V	W	X	Y
70L-(BL,C)-() ☞	\$5,705.	\$5,991.	\$6,282.	\$6,495.	\$6,678.	\$6,846.	\$7,030.	\$7,494.	\$8,345.	\$9,513.	\$10,477.	\$12,949.	\$13,379.	\$13,642.
74Y-(BL,C)-() ☞	1,682.	1,753.	1,830.	1,886.	1,934.	1,979.	2,028.	2,146.	2,362.	2,570.	2,851.	3,460.	3,572.	3,640.

Construction

Base:
Steel wire with a polished chrome finish or matte black powder-coat.

Frame and upholstery:
Foam over molded, reinforced fiberglass shell on chair. Foam cushion over molded plywood platform on ottoman. Separate seat, back, and ottoman cushions constructed of polyester fiber with foam core.

Glides:
Stainless steel and nylon articulating glides.

Medium and Child's Womb Chairs:
Medium Womb chair and ottoman are 85% scale of standard Womb chair. Child's Womb chair is 75% scale of standard chair. Child's chair does not have accompanying ottoman.

Approved KnollTextiles Grades/Fabrics

A Alignment # Bocce Cat's Cradle Common Ground # Commuter Cloth # Crossroad Delite Hourglass Mariner Overture Prep Soliloquy * Sonnet Uni-Form	B continued Sutton # Tabloid Tinge Versa Westwood Zipline	C Atlas Cairo Charm Circa Classic Boucle Dahlia CR Durand Earthwork Echo Empire Stripe * Entourage * Essence Fibra Greenwich Hudson Hula Hoop Kaleidoscope CR Kora CR * Lagos Legend CR Lore CR Metro Milestone Palisade Posh Pullman Quark Roundtrip Sequin CR * Smart Spectator * Spot On * Star Struck Swing Tilden Tower Grid Treble CR Wit Zari CR *	D Compass CR Coterie Eclat Weave Island Masquerade Menagerie Origins Woodland	E Aegean Cleo Highland Ikat Stripe Juno Katazome Kimono Mamba Marquee Meroe Midpoint Nature Walk Shima Vatera Whip	F Atelier Biscayne Cornaro * Glider Icon Intrigue In Stitches Liberty Mod Plaid Rivington Soon Topography	G Alter Ego Andissa Gibson Haze Kamani Melange Modern Tweed Serendipity Spencer Straie Stripe Ultrasuede # Utrillo	H Arno Bavaria Catwalk Constance Firefly Magritte Stretch Appeal *	I Aswan Byron * Cato Cummings * Diamond Days Dynamic Ita Jaipur Knoll Velvet Limani Olema Piper Rutledge Sandis Vermeer Zimba
--	--	--	---	---	---	--	---	---

Spinneybeck Leather

U Vicenza # Volo #	X Ducale #+ Ducale Velour #
V Acqua # Andes # Embossed Tipped # España #+ Velluto Pelle #	Y Cervo # Copenhagen # Distressed #+ Lucca # Marissa # Portofino #+ Riva # Torello #
W Alaska # Amazon # Antique # Derby # Forte # Lucente # Sabrina #	Note: All KnollTextiles and COM fabrics are railroaded on the Womb chair.

* Approved for chair and ottoman cushion upholstery only.
+ Not approved for small and medium Womb chairs and ottomans.
Approved for Cal 133 upholstery.

Check with your KnollTextile or Spinneybeck Representative for any changes or additions.

Eero Saarinen

Womb Chair, Ottoman and Settee

description	seat h	arm h	w	d	h	textile fabric yds.	req. leather sq. ft.	weight
73L Womb Settee	16"	20½"	62¼"	34"	35½"	11.4	385	–

Designer(s):
Eero Saarinen, 1948

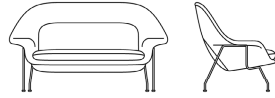

Order Code	Ordering Information
<i>Example:</i> 70LM-BL-K530/4	
70LM	Medium womb chair
BL	Black base
K530/4	Lyonese Velvet, Cognac

Note:
The Womb chair and ottoman and Womb Settee are part of a collection. Please refer to Saarinen side and executive chairs and tables on pages 242 and 366.

- Specify:
1. Pattern number/size
 2. Base finish selection
 3. Cal 133 option
 4. Split upholstery option (add S)
 5. Textile selection

Base finishes:
Black (suffix BL)
☞ Polished Chrome (suffix C)

Upholstery/COM information:
Prices shown include fabric or leather upholstery. Contact your Knoll representative for colors. Only approved KnollTextiles and Spinneybeck leathers may be ordered.

Customer's Own Material is available pending approval. For approval requirements, processing instructions and ordering information please see page 18.

☞ **KnollStudio 20-day Program:**
The standard Womb chair and ottoman are available in a chrome finish on the 20-day program upholstered with in-stock KnollTextile. For more information, please consult pages 30-33.

Split upholstery option:
The surround and cushions of the Womb chair and ottoman and Womb settee may be specified with split upholstery. Indicate S before selected surround upholstery, followed by selected cushion upholstery. Price equals the higher upholstery grade.

COM split fabric requirements:
75% Womb chair body: 3.5 yards
75% Womb chair seat/back: 1.25 yards
85% Womb chair body: 3.75 yards
85% Womb chair seat/back: 1.25 yards
85% Ottoman body: 1 yard
85% Ottoman cushion: .75 yards
100% Womb chair body: 5.50 yards
100% Womb chair seat/back: 2 yards
100% Ottoman body: 1 yard
100% Ottoman cushion: 1.25 yards
100% Womb settee body: 9 yards
100% Womb settee seat/back: 2.6 yards

COL split leather requirements:
75% Womb chair body: 90 square ft
75% Womb chair seat/back: 23 square ft
85% Womb chair body: 96 square ft
85% Womb chair seat/back: 25 square ft
85% Ottoman body: 48 square ft
85% Ottoman cushion: 25 square ft
100% Womb chair body: 110 square ft
100% Womb chair seat/back: 40 square ft
100% Ottoman body: 27.5 square ft
100% Ottoman cushion: 27.5 square ft
100% Womb settee body: 275 square ft
100% Womb settee seat/back: 110 square ft

Maintenance:
See pages 28-29.

Cal 133 Fire Code #:
The Womb Chair, Ottoman, and Settee comply with the California Technical Bulletin 133 standard if upholstered in Cal 133 approved upholstery. Specify suffix -C at end of pattern number and suffix -133 at end of textile selection. Upcharge applies, see page 19.

Note:
The Saarinen Womb chair and ottoman and Womb settee are Greenguard certified.

pattern no.	grades	COM								COL					
	A	B	C	D	E	F	G	H	I	U	V	W	X	Y	
73L-(BL,C)-()	\$8,863.	\$9,307.	\$9,757.	\$10,089.	\$10,372.	\$10,635.	\$10,921.	\$11,641.	\$12,963.	\$14,777.	\$16,276.	\$20,115.	\$20,781.	\$21,190.	

Construction

Base:
Steel wire with a polished chrome finish or matte black powder-coat.

Frame and upholstery:
Foam over molded, reinforced fiberglass shell on chair. Foam cushion over molded plywood platform on ottoman. Separate seat, back, and ottoman cushions constructed of polyester fiber with foam core.

Glides:
Stainless steel and nylon articulating glides.

Medium and Child's Womb Chairs:
Medium Womb chair and ottoman are 85% scale of standard Womb chair. Child's Womb chair is 75% scale of standard chair. Child's chair does not have accompanying ottoman.

Approved KnollTextiles Grades/Fabrics

- A** Alignment #
Bocce
Cat's Cradle
Common Ground #
Commuter Cloth #
Crossroad
Delite
Hourglass
Mariner
Overture
Prep
Soliloquy *
Sonnet
Uni-Form
- B** continued
Sutton #
Tabloid
Tinge
Versa
Westwood
Zipline
- C** Atlas
Cairo
Charm
Circa
Classic Boucle
Dahlia CR
Durand
Earthwork
Echo
Empire Stripe *
Entourage *
Essence
Fibra
Greenwich
Hudson
Hula Hoop
Kaleidoscope CR
Kora CR *
Lagos
Legend CR
Lore CR
Metro
Milestone
Palisade
Posh
Pullman
Quark
Roundtrip
Sequin CR *
Smart
Spectator *
Spot On *
Star Struck
Swing
Tilden
Tower Grid
Trebble CR
Wit
Zari CR *
- B** Abacus #
Argyle
Belize
Bistro #
Calypso
Cameo
Chronicle
Diva
Dovetail #
Ferry
Grande
Grandview
Helios
Holbrook
Journey #
Keaton
Knoll Felt
Knoll Hopsack
Little Devil
Ludlow
Melody
Mini Stitch #
Paradigm
Pogo
Prairie
Prim #
Radiance
Ransom
Roam
Rush Hour
Spark
Spree
Summit

- D** Compass CR
Coterie
Eclat Weave
Island
Masquerade
Menagerie
Origins
Woodland
- E** Aegean
Cleo
Highland
Ikat Stripe
Juno
Katazome
Kimono
Mamba
Marquee
Meroe
Midpoint
Nature Walk
Shima
Vatera
Whip
- F** Atelier
Biscayne
Cornaro *
Glider
Icon
Intrigue
In Stitches
Liberty
Mod Plaid
Rivington
Soon
Topography
- G** Alter Ego
Andissa
Gibson
Haze
Kamani
Melange
Modern Tweed
Serendipity
Spencer
Straie Stripe
Ultrasuede #
Utrillo
- H** Arno
Bavaria
Catwalk
Constance
Firefly
Magritte
Stretch Appeal *
- I** Aswan
Byron *
Cato
Cummings *
Diamond Days
Dynamic
Ita
Jaipur
Knoll Velvet
Limani
Olema
Piper
Rutledge
Sandis
Vermeer
Zimba

Spinneybeck Leather



- U** Vicenza #
Volo #
 - V** Acqua #
Andes #
Embossed Tipped #
España #+
Velluto Pelle #
 - W** Alaska #
Amazon #
Antique #
Derby #
Forte #
Lucente #
Sabrina #
 - X** Ducale #+
Ducale Velour #
 - Y** Cervo #
Copenhagen #
Distressed #+
Lucca #
Marissa #
Portofino #+
Riva #
Torello #
- Note:** All KnollTextiles and COM fabrics are railroaded on the Womb chair.

* Approved for chair and ottoman cushion upholstery only.
+ Not approved for small and medium Womb chairs and ottomans.
Approved for Cal 133 upholstery.

Check with your KnollTextile or Spinneybeck Representative for any changes or additions.

Eero Saarinen

Womb Chair, Ottoman and Settee

	description	seat h	arm h	w	d	h	textile fabric yds.	req. leather sq. ft.	weight
<i>Designer(s):</i> Eero Saarinen, 1948	70LM Medium Womb chair	15"	18"	35"	31"	31 1/4"	5	96	31 lbs.
									
									
	74YM Medium ottoman			21"	17 1/2"	14 1/4"	1.7	48	11 lbs.
									

Order Code	Ordering Information
<i>Example:</i> 70LM-BL-K530/4	
70LM	Medium womb chair
BL	Black base
K530/4	Lyonese Velvet, Cognac

Note:
The Womb chair and ottoman and Womb Settee are part of a collection. Please refer to Saarinen side and executive chairs and tables on pages 242 and 366.

- Specify:*
1. Pattern number/size
 2. Base finish selection
 3. Cal 133 option
 4. Split upholstery option (add S)
 5. Textile selection

Base finishes:
Black (suffix BL)
 Polished Chrome (suffix C)

Upholstery/COM information:
Prices shown include fabric or leather upholstery. Contact your Knoll representative for colors. Only approved KnollTextiles and Spinneybeck leathers may be ordered.

Customer's Own Material is available pending approval. For approval requirements, processing instructions and ordering information please see page 18.

 *KnollStudio 20-day Program:*
The standard Womb chair and ottoman are available in a chrome finish on the 20-day program upholstered with in-stock KnollTextile. For more information, please consult pages 30-33.

Split upholstery option:
The surround and cushions of the Womb chair and ottoman and Womb settee may be specified with split upholstery. Indicate S before selected surround upholstery, followed by selected cushion upholstery. Price equals the higher upholstery grade.

COM split fabric requirements:
75% Womb chair body: 3.5 yards
75% Womb chair seat/back: 1.25 yards
85% Womb chair body: 3.75 yards
85% Womb chair seat/back: 1.25 yards
85% Ottoman body: 1 yard
85% Ottoman cushion: .75 yards
100% Womb chair body: 5.50 yards
100% Womb chair seat/back: 2 yards
100% Ottoman body: 1 yard
100% Ottoman cushion: 1.25 yards
100% Womb settee body: 9 yards
100% Womb settee seat/back: 2.6 yards

COL split leather requirements:
75% Womb chair body: 90 square ft
75% Womb chair seat/back: 23 square ft
85% Womb chair body: 96 square ft
85% Womb chair seat/back: 25 square ft
85% Ottoman body: 48 square ft
85% Ottoman cushion: 25 square ft
100% Womb chair body: 110 square ft
100% Womb chair seat/back: 40 square ft
100% Ottoman body: 27.5 square ft
100% Ottoman cushion: 27.5 square ft
100% Womb settee body: 275 square ft
100% Womb settee seat/back: 110 square ft

Maintenance:
See pages 28-29.

Cal 133 Fire Code #:
The Womb Chair, Ottoman, and Settee comply with the California Technical Bulletin 133 standard if upholstered in Cal 133 approved upholstery. Specify suffix -C at end of pattern number and suffix -133 at end of textile selection. Upcharge applies, see page 19.

Note:
The Saarinen Womb chair and ottoman and Womb settee are Greenguard certified.

pattern no.	grades	COM	C	D	E	F	G	H	I	COL	V	W	X	Y
70LM-(BL,C)-()	\$5,382.	\$5,651.	\$5,925.	\$6,128.	\$6,297.	\$6,458.	\$6,632.	\$7,067.	\$7,872.	\$8,974.	\$9,885.	\$12,217.	\$12,619.	\$12,870.
74YM-(BL,C)-()	1,587.	1,655.	1,730.	1,777.	1,825.	1,866.	1,913.	2,023.	2,229.	2,425.	2,658.	3,264.	3,370.	3,433.

Construction

Base:
Steel wire with a polished chrome finish or matte black powder-coat.

Frame and upholstery:
Foam over molded, reinforced fiberglass shell on chair. Foam cushion over molded plywood platform on ottoman. Separate seat, back, and ottoman cushions constructed of polyester fiber with foam core.

Glides:
Stainless steel and nylon articulating glides.

Medium and Child's Womb Chairs:
Medium Womb chair and ottoman are 85% scale of standard Womb chair. Child's Womb chair is 75% scale of standard chair. Child's chair does not have accompanying ottoman.

Approved KnollTextiles Grades/Fabrics

- A** Alignment #
Bocce
Cat's Cradle
Common Ground #
Commuter Cloth #
Crossroad
Delite
Hourglass
Mariner
Overture
Prep
Soliloquy *
Sonnet
Uni-Form
- B** continued
Sutton #
Tabloid
Tinge
Versa
Westwood
Zipline
- C**
Atlas
Cairo
Charm
Circa
Classic Boucle
Dahlia CR
Durand
Earthwork
Echo
Empire Stripe *
Entourage *
Essence
Fibra
Greenwich
Hudson
Hula Hoop
Kaleidoscope CR
Kora CR *
Lagos
Legend CR
Lore CR
Metro
Milestone
Palisade
Posh
Pullman
Quark
Roundtrip
Sequin CR *
Smart
Spectator *
Spot On *
Star Struck
Swing
Tilden
Tower Grid
Trebble CR
Wit
Zari CR *
- D**
Compass CR
Coterie
Eclat Weave
Island
Masquerade
Menagerie
Origins
Woodland
- E**
Aegean
Cleo
Highland
Ikat Stripe
Juno
Katazome
Kimono
Mamba
Marquee
Meroe
Midpoint
Nature Walk
Shima
Vatera
Whip
- F**
Atelier
Biscayne
Cornaro *
Glider
Icon
Intrigue
In Stitches
Liberty
Mod Plaid
Rivington
Soon
Topography

Spinneybeck Leather

- U**
Vicenza #
Volo #
- V**
Acqua #
Andes #
Embossed Tipped #
España #+
Velluto Pelle #
- W**
Alaska #
Amazon #
Antique #
Derby #
Forte #
Lucente #
Sabrina #
- X**
Ducale #+
Ducale Velour #
- Y**
Cervo #
Copenhagen #
Distressed #+
Lucca #
Marissa #
Portofino #+
Riva #
Torello #
- H**
Arno
Bavaria
Catwalk
Constance
Firefly
Magritte
Stretch Appeal *
- I**
Aswan
Byron *
Cato
Cummings *
Diamond Days
Dynamic
Ita
Jaipur
Knoll Velvet
Limani
Olema
Piper
Rutledge
Sandis
Vermeer
Zimba

* Approved for chair and ottoman cushion upholstery only.
+ Not approved for small and medium Womb chairs and ottomans.
Approved for Cal 133 upholstery.

Check with your KnollTextile or Spinneybeck Representative for any changes or additions.

Eero Saarinen

Womb Chair, Ottoman and Settee

description	seat h	arm h	w	d	h	textile fabric yds.	req. leather sq. ft.	weight
70LS Child's Womb chair	14 1/2"	17"	31"	28"	27 1/4"	5	90	27 lbs.

Designer(s):
Eero Saarinen, 1948



Order Code

<i>Example:</i>	70LM-BL-K530/4
70LM	Medium womb chair
BL	Black base
K530/4	Lyonese Velvet, Cognac

Note:
The Womb chair and ottoman and Womb Settee are part of a collection. Please refer to Saarinen side and executive chairs and tables on pages 242 and 366.

Specify:

1. Pattern number/size
2. Base finish selection
3. Cal 133 option
4. Split upholstery option (add S)
5. Textile selection

Ordering Information

Base finishes:
Black (suffix BL)
Polished Chrome (suffix C)

Upholstery/COM information:
Prices shown include fabric or leather upholstery. Contact your Knoll representative for colors. Only approved KnollTextiles and Spinneybeck leathers may be ordered.

Customer's Own Material is available pending approval. For approval requirements, processing instructions and ordering information please see page 18.

KnollStudio 20-day Program:
The standard Womb chair and ottoman are available in a chrome finish on the 20-day program upholstered with in-stock KnollTextile. For more information, please consult pages 30-33.

Split upholstery option:
The surround and cushions of the Womb chair and ottoman and Womb settee may be specified with split upholstery. Indicate S before selected surround upholstery, followed by selected cushion upholstery. Price equals the higher upholstery grade.

COM split fabric requirements:
75% Womb chair body: 3.5 yards
75% Womb chair seat/back: 1.25 yards
85% Womb chair body: 3.75 yards
85% Womb chair seat/back: 1.25 yards
85% Ottoman body: 1 yard
85% Ottoman cushion: .75 yards
100% Womb chair body: 5.50 yards
100% Womb chair seat/back: 2 yards
100% Ottoman body: 1 yard
100% Ottoman cushion: 1.25 yards
100% Womb settee body: 9 yards
100% Womb settee seat/back: 2.6 yards

COL split leather requirements:
75% Womb chair body: 90 square ft
75% Womb chair seat/back: 23 square ft
85% Womb chair body: 96 square ft
85% Womb chair seat/back: 25 square ft
85% Ottoman body: 48 square ft
85% Ottoman cushion: 25 square ft
100% Womb chair body: 110 square ft
100% Womb chair seat/back: 40 square ft
100% Ottoman body: 27.5 square ft
100% Ottoman cushion: 27.5 square ft
100% Womb settee body: 275 square ft
100% Womb settee seat/back: 110 square ft

Maintenance:
See pages 28-29.

Cal 133 Fire Code:
The Womb Chair, Ottoman, and Settee comply with the California Technical Bulletin 133 standard if upholstered in Cal 133 approved upholstery. Specify suffix -C at end of pattern number and suffix -133 at end of textile selection. Upcharge applies, see page 19.

Note:
The Saarinen Womb chair and ottoman and Womb settee are Greenguard certified.

pattern no.	grades	COM	C	D	E	F	G	H	I	COL	V	W	X	Y
70LS-(BL,C)-()	\$4,844.	\$5,086.	\$5,331.	\$5,514.	\$5,670.	\$5,813.	\$5,970.	\$6,361.	\$7,086.	\$8,077.	\$8,896.	\$10,995.	\$11,359.	\$11,582.

Construction

Base:
Steel wire with a polished chrome finish or matte black powder-coat.

Frame and upholstery:
Foam over molded, reinforced fiberglass shell on chair. Foam cushion over molded plywood platform on ottoman. Separate seat, back, and ottoman cushions constructed of polyester fiber with foam core.

Glides:
Stainless steel and nylon articulating glides.

Medium and Child's Womb Chairs:
Medium Womb chair and ottoman are 85% scale of standard Womb chair. Child's Womb chair is 75% scale of standard chair. Child's chair does not have accompanying ottoman.

Approved KnollTextiles Grades/Fabrics

A Alignment # Bocce Cat's Cradle Common Ground # Commuter Cloth # Crossroad Delite Hourglass Mariner Overture Prep Soliloquy * Sonnet Uni-Form	B continued Sutton # Tabloid Tinge Versa Westwood Zipline	C Atlas Cairo Charm Circa Classic Boucle Dahlia CR Durand Earthwork Echo Empire Stripe * Entourage * Essence Fibra Greenwich Hudson Hula Hoop Kaleidoscope CR Kora CR * Lagos Legend CR Lore CR Metro Milestone Palisade Posh Pullman Quark Roundtrip Sequin CR * Smart Spectator * Spot On * Star Struck Swing Tilden Tower Grid Trebble CR Wit Zari CR *	D Compass CR Coterie Eclat Weave Island Masquerade Menagerie Origins Woodland	E Aegean Cleo Highland Ikat Stripe Juno Katazome Kimono Mamba Marquee Meroe Midpoint Nature Walk Shima Vatera Whip	F Atelier Biscayne Cornaro * Glider Icon Intrigue In Stitches Liberty Mod Plaid Rivington Soon Topography	G Alter Ego Andissa Gibson Haze Kamani Melange Modern Tweed Serendipity Spencer Straie Stripe Ultrasuede # Utrillo	H Arno Bavaria Catwalk Constance Firefly Magritte Stretch Appeal *	I Aswan Byron * Cato Cummings * Diamond Days Dynamic Ita Jaipur Knoll Velvet Limani Olema Piper Rutledge Sandis Vermeer Zimba	U Vicenza # Volo #	V Acqua # Andes # Embossed Tipped # España #+ Velluto Pelle #	W Alaska # Amazon # Antique # Derby # Forte # Lucente # Sabrina #	X Ducale #+ Ducale Velour #	Y Cervo # Copenhagen # Distressed #+ Lucca # Marissa # Portofino #+ Riva # Torello #
---	--	--	--	--	--	---	--	--	---------------------------------	---	---	--	---



Spinneybeck Leather

All KnollTextiles and COM fabrics are railroaded on the Womb chair.

* Approved for chair and ottoman cushion upholstery only.
+ Not approved for small and medium Womb chairs and ottomans.
Approved for Cal 133 upholstery.

Check with your KnollTextile or Spinneybeck Representative for any changes or additions.

Richard Schultz
1966 Collection® Dining Chairs

	description	seat h	arm h	w	d	h	textile fabric yds.	weight
<p><i>Designer(s):</i> Richard Schultz, 1966</p>  	1966-45H Dining chair with arms	18"	25"	23"	24 1/4"	31"		22 lbs.
	1966-45HCOV Dining chair with arms cover	—	—	—	—	—		—
	1966-46H Dining chair, armless	18"		19"	24 1/4"	31"		20 lbs.
	1966-46HCOV Dining chair, armless, cover							
	1966-45P Chair pad for 1966-45H, 46H, 46C, 46B						1.25	



pattern no.		COM	
1966-45H-()-()			
	\$1,994.		
1966-45HCOV			335.
1966-46H-()-()			1,994.
1966-46HCOV			335.
1966-45P		572.	600.

Order Code	Ordering Information
<i>Example:</i> 1966-45H-B-W-W	<i>Strap finishes:</i>
1966-45H Dining chair with arms	White (suffix W)
B Brown straps	Brown (suffix B)
W White mesh	Grey (suffix G)
W White frame	Onyx (suffix O)
	Sand (suffix S)
	Bronze (suffix Z)
	<i>Mesh finishes:</i>
	White (suffix W)
	Grey Tone (suffix T)
	Onyx (suffix O)
	Aluminum (suffix A)
	Bronze (suffix Z)
	Chestnut (suffix N)
	<i>Frame finishes:</i>
	Blue (suffix BLU)
	Chestnut (suffix N)
	Dark Bronze (suffix 14)
	Green (suffix 007)
	Light Bronze (suffix 13)
	Lime Green (suffix LGR)
	Onyx (suffix O)
	Orange (suffix ORG)
	Plum (suffix PLM)
	Sky Blue (suffix 3)
	Warm Bronze (suffix 16)
	Warm Wood (suffix 12)
	Weatherable Silver (suffix S)
	White (suffix W)
	Yellow (suffix YEL)
	<i>Maintenance:</i>
	See pages 28-29.
	<i>Upholstery/COM information:</i>
	Prices shown include fabric upholstery only. Contact your Knoll representative for colors.
	Customer's Own Material is available pending approval. For approval requirements, processing instructions and ordering information, please see page 18

Construction	Approved KnollTextiles Grades/Fabrics
<i>Frame:</i>	B
Frame is aluminum castings and extrusions welded and glued together using a two-part epoxy. Finished in highly durable weather resistant polyester powder coat paint.	Belize
	Prairie
	Vinyl
	C
	Baxter
	Noble
	Sinclair
<i>Seat:</i>	
Woven vinyl coated polyester mesh is sewn to pure vinyl straps using Teflon thread to form the seat and back. Stainless steel supports provides shape and is attached to the frame with stainless steel connectors.	
	<i>Check with your KnollTextiles Representative for changes or additions.</i>
<i>Glides:</i>	
Clear butyrate plastic.	

Designer(s):
Richard Schultz, 1966

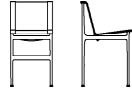

description	seat h	w	d	h	textile fabric yds.	weight
1966-46C Counter height armless barstool	26"	19"	24 1/4"	39 1/4"		24 lbs.
						
1966-46CCOV Counter height armless barstool cover						
1966-46B Bar height armless barstool	31"	19"	24 1/4"	44 1/4"		24 lbs.
						
1966-46BCOV Bar height armless barstool cover						
1966-45P Chair pad for 1966-45H, 46H, 46C, 46B					1.25	

pattern no.	COM	
1966-46C-()-()		\$2,245.
1966-46CCOV		428.
1966-46B-()-()		2,499.
1966-46BCOV		468.
1966-45P	572.	600.

Order Code	Ordering Information
<i>Example:</i> 1966-46B-O-O-O	<i>Strap finishes:</i>
1966-46B Bar height barstool	White (suffix W)
O Onyx strap	Brown (suffix B)
O Onyx mesh	Grey (suffix G)
O Onyx frame	Onyx (suffix O)
	Sand (suffix S)
	Bronze (suffix Z)
	<i>Mesh finishes:</i>
	White (suffix W)
	Grey Tone (suffix T)
	Onyx (suffix O)
	Aluminum (suffix A)
	Bronze (suffix Z)
	Chestnut (suffix N)
	<i>Frame finishes:</i>
	Blue (suffix BLU)
	Chestnut (suffix N)
	Dark Bronze (suffix 14)
	Green (suffix 007)
	Light Bronze (suffix 13)
	Lime Green (suffix LGR)
	Onyx (suffix O)
	Orange (suffix ORG)
	Plum (suffix PLM)
	Sky Blue (suffix 3)
	Warm Bronze (suffix 16)
	Warm Wood (suffix 12)
	Weatherable Silver (suffix S)
	White (suffix W)
	Yellow (suffix YEL)
	<i>Maintenance:</i>
	See pages 28-29.
	<i>Upholstery/COM information:</i>
	Prices shown include fabric upholstery only. Contact your Knoll representative for colors.
	Customer's Own Material is available pending approval. For approval requirements, processing instructions and ordering information, please see page 18



Specify:
1. Pattern number
2. Strap color
3. Mesh color
4. Frame color

Construction	Approved KnollTextiles Grades/Fabrics
<i>Frame:</i> Frame is aluminum castings and extrusions welded and glued together using a two-part epoxy. Finished in highly durable weather resistant polyester powder coat paint.	B Belize Prairie Vinyl
<i>Seat:</i> Woven vinyl coated polyester mesh is sewn to pure vinyl straps using Teflon thread to form the seat and back. Stainless steel supports provides shape and is attached to the frame with stainless steel connectors.	C Baxter Noble Sinclair
<i>Glides:</i> Clear butyrate plastic.	<i>Check with your KnollTextiles Representative for changes or additions.</i>

Richard Schultz
1966 Collection® Lounge Seating

Designer(s):
Richard Schultz, 1966

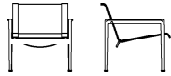
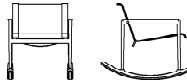
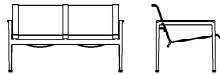
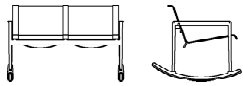
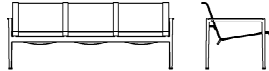

description	seat h	arm h	w	d	h	textile fabric yds.	weight
1966-25 Lounge chair with arms 	14"	20 1/2"	26"	28 1/4"	26"		24 lbs.
1966-25COV Lounge chair with arms, cover							
1966-25R Single Rocker 	14"	20 1/2"	26"	35"	29"		30 lbs.
1966-25RCOV Single Rocker, cover							
1966-255 Two seat lounge chair with arms 	14"	20 1/2"	46"	28 1/4"	26"		28 lbs.
1966-255COV Two seat lounge chair with arms, cover							
1966-255R Double Rocker 	14"	20 1/4"	46"	35"	29"		34 lbs.
1966-255RCOV Double Rocker, cover							
1966-355 Three seat lounge chair with arms 	14"	20 1/2"	66"	28 1/4"	26"		32 lbs.
1966-355COV Three seat lounge chair with arms, cover							
1966-250 ottoman 			23"	27"	14"		12 lbs.
1966-250COV ottoman cover							
1966-25P Chair pad for 1966-25, 25R, 255, 255R, 355						1.5	
1966-250P Ottoman pad for 1966-250						1.25	

Order Code

Ordering Information

Example: **1966-25-G-T-S**

1966-25	Lounge chair with arms
G	Grey strap
T	Grey Tone mesh
S	Weatherable Silver frame

Strap finishes:
White (suffix W)
Brown (suffix B)
Grey (suffix G)
Onyx (suffix O)
Sand (suffix S)
Bronze (suffix Z)

Mesh finishes:
White (suffix W)
Grey Tone (suffix T)
Onyx (suffix O)
Aluminum (suffix A)
Bronze (suffix Z)
Chestnut (suffix N)

Frame finishes:
Blue (suffix BLU)
Chestnut (suffix N)
Dark Bronze (suffix 14)
Green (suffix 007)
Light Bronze (suffix 13)
Lime Green (suffix LGR)
Onyx (suffix O)
Orange (suffix ORG)
Plum (suffix PLM)
Sky Blue (suffix 3)
Warm Bronze (suffix 16)
Warm Wood (suffix 12)
Weatherable Silver (suffix S)
White (suffix W)
Yellow (suffix YEL)

Maintenance:
See pages 28-29.

Upholstery/COM information:
Prices shown include fabric upholstery only. Contact your Knoll representative for colors.

Customer's Own Material is available pending approval. For approval requirements, processing instructions and ordering information, please see page 18

Specify:

1. Pattern number
2. Strap color
3. Mesh color
4. Frame color

pattern no.	COM	
1966-25-()-()-()		\$2,182.
1966-25COV		395.
1966-25R-()-()-()		2,762.
1966-25RCOV		466.
1966-255-()-()-()		2,984.
1966-255COV		700.
1966-255R-()-()-()		3,952.
1966-255RCOV		831.
1966-355-()-()-()		3,937.
1966-355COV		963.
1966-250-()-()-()		1,929.
1966-250COV		512.
1966-25P	493.	527.
1966-250P	458.	487.

Construction

Frame:
Frame is aluminum castings and extrusions welded and glued together using a two-part epoxy. Finished in highly durable weather resistant polyester powder coat paint.

Seat:
Woven vinyl coated polyester mesh is sewn to pure vinyl straps using Teflon thread to form the seat and back. Stainless steel supports provides shape and is attached to the frame with stainless steel connectors.



Glides:
Clear butyrate plastic.

Approved KnollTextiles Grades/Fabrics

- B** Belize
Prairie
Vinyl
- C** Baxter
Noble
Sinclair

Check with your KnollTextiles Representative for changes or additions.

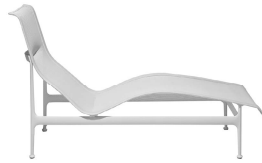
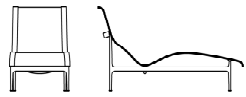
Richard Schultz
1966 Collection® Chaise Lounge Chairs

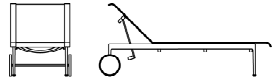
	description	seat h	w	d	h	textile fabric	
						yds.	weight
<i>Designer(s):</i> Richard Schultz, 1966 	1966-41 Contour chaise lounge	13"	24½"	58"	33¾"		32 lbs.
							
	1966-41COV Contour chaise lounge cover						
	1966-42 Adjustable chaise lounge	14¾"	25½"	76"	36"		37 lbs.
							
	1966-42COV Adjustable chaise lounge cover						
	1966-41P 1966 Contour chaise pad					2.5	
	1966-42P 1966 Adjustable chaise pad					2.5	

pattern no.	COM	
1966-41-(-)-(-)		\$3,409.
1966-41COV		986.
1966-42-(-)-(-)		4,534.
1966-42COV		853.
1966-41P	913.	969.
1966-42P	714.	772.

Order Code	Ordering Information
<i>Example:</i> 1966-41-W-W-W	<i>Strap finishes:</i>
1966-41 Contour chaise lounge	White (suffix W)
W White strap	Brown (suffix B)
W White mesh	Grey (suffix G)
W White frame	Onyx (suffix O)
	Sand (suffix S)
	Bronze (suffix Z)
	<i>Mesh finishes:</i>
	White (suffix W)
	Grey Tone (suffix T)
	Onyx (suffix O)
	Aluminum (suffix A)
	Bronze (suffix Z)
	Chestnut (suffix N)
	<i>Frame finishes:</i>
	Blue (suffix BLU)
	Chestnut (suffix N)
	Dark Bronze (suffix 14)
	Green (suffix 007)
	Light Bronze (suffix 13)
	Lime Green (suffix LGR)
	Onyx (suffix O)
	Orange (suffix ORG)
	Plum (suffix PLM)
	Sky Blue (suffix 3)
	Warm Bronze (suffix 16)
	Warm Wood (suffix 12)
	Weatherable Silver (suffix S)
	White (suffix W)
	Yellow (suffix YEL)
	<i>Maintenance:</i>
	See pages 28-29.
	<i>Upholstery/COM information:</i>
	Prices shown include fabric upholstery only. Contact your Knoll representative for colors.
	Customer's Own Material is available pending approval. For approval requirements, processing instructions and ordering information, please see page 18

- Specify:*
1. Pattern number
 2. Strap color
 3. Mesh color
 4. Frame color

Construction	Approved KnollTextiles Grades/Fabrics
<i>Frame:</i>	B
Frame is aluminum castings and extrusions welded and glued together using a two-part epoxy. Finished in highly durable weather resistant polyester powder coat paint.	Belize
	Prairie
	Vinyl
	C
	Baxter
	Noble
	Sinclair
<i>Seat:</i>	
Woven vinyl coated polyester mesh is sewn to pure vinyl straps using Teflon thread to form the seat and back. Stainless steel supports provides shape and is attached to the frame with stainless steel connectors.	<i>Check with your KnollTextiles Representative for changes or additions.</i>
<i>Glides:</i>	
Clear butyrate plastic.	

	description	seat h	w	d	h	textile fabric yds.	weight
<p><i>Designer(s):</i> Richard Schultz, 2007</p> 	SWELL-31 single seat club chair	16 1/2"	30"	31 1/2"	28"		22 lbs.
	SWELL-31COV single seat club chair cover						
	SWELL-32 two seat sofa	16 1/2"	58 1/2"	31 1/2"	28"		42 lbs.
	SWELL-32COV two seat sofa cover						
	SWELL-33 three seat sofa	16 1/2"	87"	31 1/2"	28"		63 lbs.
	SWELL-33COV three seat sofa cover						
	SWELL-20P 20" square pillow for SWELL-31, 32, 33					0.75	
SWELL-31P Seat pad for SWELL-31, 32, 33					2.75		

pattern no.		COM	
SWELL-31-()-()-()	\$3,149.		
SWELL-31COV	483.		
SWELL-32-()-()-()	4,965.		
SWELL-32COV	806.		
SWELL-33-()-()-()	6,324.		
SWELL-33COV	1,014.		
SWELL-20P		252.	268.
SWELL-31P		981.	1,043.





Order Code	Ordering Information
<i>Example:</i> SWELL-33-B-W-W	<i>Strap finishes:</i>
SWELL-33 Three seat sofa	White (suffix W)
B Brown strap	Brown (suffix B)
W White mesh	Grey (suffix G)
W White frame	Onyx (suffix O)
	Sand (suffix S)
	Bronze (suffix Z)
	<i>Mesh finishes:</i>
	White (suffix W)
	Grey Tone (suffix T)
	Onyx (suffix O)
	Aluminum (suffix A)
	Bronze (suffix Z)
	Chestnut (suffix N)
	<i>Frame finishes:</i>
	Blue (suffix BLU)
	Chestnut (suffix N)
	Dark Bronze (suffix 14)
	Green (suffix 007)
	Light Bronze (suffix 13)
	Lime Green (suffix LGR)
	Onyx (suffix O)
	Orange (suffix ORG)
	Plum (suffix PLM)
	Sky Blue (suffix 3)
	Warm Bronze (suffix 16)
	Warm Wood (suffix 12)
	Weatherable Silver (suffix S)
	White (suffix W)
	Yellow (suffix YEL)
	<i>Maintenance:</i>
	See pages 28-29.
	<i>Upholstery/COM information:</i>
	Prices shown include fabric upholstery only. Contact your Knoll representative for colors.
	Customer's Own Material is available pending approval. For approval requirements, processing instructions and ordering information, please see page 18

Construction	Approved KnollTextiles Grades/Fabrics
<i>Frame:</i>	B
Frame is aluminum castings and extrusions welded and glued together using a two-part epoxy. Finished in highly durable weather resistant polyester powder coat paint.	Belize
	Prairie
	Vinyl
	C
	Baxter
	Noble
	Sinclair
<i>Seat:</i>	
Woven vinyl coated polyester mesh is sewn to pure vinyl straps using Teflon thread to form the seat and back. Stainless steel supports provides shape and is attached to the frame with stainless steel connectors.	<i>Check with your KnollTextiles Representative for changes or additions.</i>
<i>Glides:</i>	
Clear butyrate plastic.	

Richard Schultz
Topiary® Seating Collection

Designer(s):
 Richard Schultz, 1996



description	seat h	arm h	w	d	h	textile fabric yds.	weight
TOP-45 Topiary dining chair	18"	25"	26 1/2"	24"	34"		38 lbs.
							
TDCP Chair pad for Topiary dining chair TOP-45						1.0	
TOP-45COV Topiary dining chair cover							
TOP-25 Topiary lounge chair	16"	21 1/2"	32"	32"	30 1/2"		45 lbs.
							
TLCP Chair pad for Topiary lounge chair TOP-25						1.0	
TOP-25COV Topiary lounge chair cover							
TOP-455 Topiary bench	18"	25"	55"	26"	34 1/2"		84 lbs.
							
TBP Chair pad for Topiary bench TOP-455						2.0	
TOP-455COV Topiary bench cover							
TOP-250 Topiary small ottoman/end table			20 3/4"	22"	15"		23 lbs.
							
TSOP Seat pad for Topiary ottoman TOP-250						1.0	
TOP-250COV Topiary small ottoman/end table cover							
TOP-15 Topiary stacking chair	18 1/4"		22"	21"	30 1/4"		23 lbs.
							
TSC Chair pad for Topiary stacking chair TOP-15						1.0	
TSCOV Topiary stacking chair cover							
TSCOV4 Topiary stacking chair cover for stack of four							

Order Code

Example:	TOP-455-1
TOP-455	Bench
1	Forest Green finish

Specify:
 1. Pattern number
 2. Finish color

Ordering Information

Finishes:	Sky Blue (suffix 3)
Blue (suffix BLU)	Terra Cotta (suffix 5)
Chestnut (suffix N)	Warm Bronze (suffix 16)
Choice White (suffix 6)	Warm Wood (suffix 12)
Daffodil Yellow (suffix 2)	Weatherable Silver (suffix S)
Dark Bronze (suffix 14)	White (suffix W)
Forest Green (suffix 1)	Yellow (suffix YEL)
Green (suffix 007)	
Light Bronze (suffix 13)	
Lime Green (suffix LGR)	
Onyx (suffix 0)	
Orange (suffix ORG)	
Plum (suffix PLM)	

Maintenance:
 See pages 28-29.

Upholstery/COM information:
 Prices shown include fabric upholstery only. Contact your Knoll representative for colors.

Customer's Own Material is available pending approval. For approval requirements, processing instructions and ordering information, please see page 18

pattern no.		COM	
TOP-45- ()	\$1,962.	B	C
TDCP		347.	370.
TOP-45COV	432.		
TOP-25- ()	2,536.		
TLCP		370.	477.
TOP-25COV	463.		
TOP-455- ()	3,759.		
TBP		723.	772.
TOP-455COV	836.		
TOP-250- ()	1,670.		
TSOP		458.	480.
TOP-250COV	381.		
TOP-15- ()	1,386.		
TSC		463.	486.
TSCOV	669.		
TSCOV4	798.		

Construction

Topiary frame:
 3/16" aluminum sheet stamped and formed. Stainless steel connectors and finished in highly durable weather resistant polyester powder coat paint. Clear butyrate plastic glides.

Stacking Chair:
 Seat and back is 3/16" aluminum sheet stamped and formed. Stainless steel connectors and finished in highly durable weather resistant polyester powder coat paint. Legs are 1" diameter stainless steel tubes attached to the seat using stainless steel connectors. Grey vinyl bumpers protect seats when stacked. Glides are natural color injection molded nylon.

Stacking:
 Topiary stacking chair stacks 15 high.

Approved KnollTextiles Grades/Fabrics

- B** Belize
 Prairie
 Vinyl
- C** Baxter
 Noble
 Sinclair

Check with your KnollTextiles Representative for changes or additions.

Shelton Mindel

Shelton Mindel Side Chair

Designer(s):
Peter Shelton and Lee Mindel,
2006

Award(s):
Good Design Award, 2006

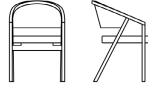
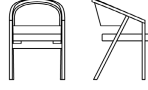

description	seat h	arm h	w	d	h	textile fabric yds.	leather sq. ft.	weight	finish				
										grades	COM	C	D
SM8A Arm chair 	18"	23 1/2"	22"	23 1/2"	32"	1	18	19 lbs.	Other finishes				
	18"	23 1/2"	22"	23 1/2"	32"	1	18	24 lbs.	Golden Oak, Maple				
	18"	23 1/2"	22"	23 1/2"	32"	1	18	22 lbs.	Light Walnut				
SM8A-U Arm chair, fully uph. 	18"	23 1/2"	22"	23 1/2"	32"	1.5	27	20 lbs.	Other finishes				
	18"	23 1/2"	22"	23 1/2"	32"	1.5	27	25 lbs.	Golden Oak, Maple				
	18"	23 1/2"	22"	23 1/2"	32"	1.5	27	23 lbs.	Light Walnut				
SM8R seat basket replacement for SM8A and SM8A-U						1	18						

Order Code	Ordering Information	Construction
------------	----------------------	--------------

Example: **SM8A-B312-K162/20**
SM8A Shelton Mindel side chair, seat upholstery only
B312 Bronzed Cherry
K162/20 Classic Boucle, Neutral

Oak with light lacquer finish:
Golden Oak (suffix GO)

Walnut with light lacquer finish:
Light Walnut (suffix LWT)

Maple:
Clear Maple (suffix KC)

Beech frame stains:
Bronzed Cherry (suffix B312A)
Burnt Walnut (suffix B313)
Ebonized (suffix BE)
Light Cherry (suffix B315)
Light Walnut (suffix B411)
Medium Cherry (suffix B319)
Medium Red Mahogany (suffix BR)
Medium Walnut (suffix B323)
Natural Beech (suffix BN)
Peacock Green Walnut (suffix B415)
Smoked Walnut (suffix B418)

KnollStudio wood finishes:
KnollStudio wood finishes complement a large variety of KnollStudio veneer and Knoll Office veneer finishes. To select correct complementary finish, please refer to KnollStudio Wood Finish Matrix on page 25. If no complementary standard finish is available, please refer to custom finish policy below.

Custom finishes:
Complementary finishes to any KnollStudio or Knoll Office wood finish are available at no upcharge. To complement non-Knoll wood veneer or lumber finishes, a one-time, non-negotiable net upcharge of \$662 applies. Re-orders are at no upcharge. Please contact your KnollStudio representative, dealer or Customer Service associate for complete custom finish information and Order Code. Minimum order quantity for any custom finish order: 4 chairs.

Frame:
Available in Beech, Walnut and Oak hardwood with mortise and tenon construction.

Upholstered Seat:
1 1/4" thick seat filled with high density polyurethane foam, with elastic webbing suspension in a cross weave. Seat frame is constructed of 1" plywood.

Fully Upholstered:
Inside back upholstery is inset in frame. * indicates approved textiles and leathers.

Finish:
Satin catalyzed lacquer finish. Oak and Walnut versions have lower sheen.

The Shelton Mindel side chair is part of a collection. Please refer to the SM lounge collections starting on page 274 and the SM table collection on page 398.

Specify:
1. Pattern number
2. Finish selection
3. Textile selection

Upholstery/COM information:
Prices shown include fabric or leather upholstery. Contact your Knoll representative for colors. Only approved KnollTextiles and Spinneybeck leathers may be ordered.

Customer's Own Material is available pending approval. For approval requirements, processing instructions and ordering information please see page 18.

Cal 133 Fire Code:
The Shelton Mindel Side Chairs comply with the California Technical Bulletin 133 standard if upholstered in Cal 133 approved upholstery. Specify suffix -C at end of pattern number and suffix -133 at end of textile selection. Upcharge applies, see page 19.

Maintenance:
See pages 28-29.

Note:
The Shelton Mindel Side Chair is Greenguard certified.

Glides:
Chairs feature plastic glides.

Certified Wood:
Chairs manufactured using FSC certified hardwoods are available through Custom Product Development. Extended leadtime and upcharge apply.

pattern no.	grades	COM	C	D	E	F	G	H	I	COM U	V	W	X	Y
SM8A-()	\$1,731.	\$1,760.	\$1,790.	\$1,822.	\$1,848.	\$1,865.	\$1,898.	\$1,958.	\$2,002.	\$2,147.	\$2,256.	\$2,475.	\$2,523.	\$2,577.
SM8A-(GO,KC)	2,077.	2,108.	2,137.	2,168.	2,194.	2,213.	2,244.	2,307.	2,351.	2,494.	2,604.	2,826.	2,870.	2,924.
SM8A-(LWT)	2,366.	2,397.	2,427.	2,460.	2,487.	2,503.	2,534.	2,597.	2,641.	2,785.	2,892.	3,114.	3,158.	3,215.
SM8A-U-()	2,084.	2,128.	2,173.	2,220.	2,258.	2,286.	2,336.	2,427.	2,493.	2,710.	2,870.	3,203.	3,273.	3,353.
SM8A-U-(GO,KC)	2,366.	2,413.	2,454.	2,503.	2,541.	2,570.	2,619.	2,711.	2,775.	2,992.	3,153.	3,487.	3,557.	3,637.
SM8A-U-(LWT)	2,681.	2,725.	2,766.	2,816.	2,855.	2,884.	2,932.	3,024.	3,091.	3,304.	3,466.	3,799.	3,869.	3,949.
SM8R-()	468.	494.	520.	545.	569.	586.	614.	668.	706.	1,064.	1,162.	1,354.	1,393.	1,441.

Approved KnollTextiles Grades/Fabrics	Spinneybeck Leather
---------------------------------------	---------------------

A Alignment ▲
Beacon *
Bocce *
Cat's Cradle *
Chance *
Common Ground
Commuter
Cloth *▲
Crossroad
Delite *
Dristi
Hourglass *
Mariner *
Monarch *
Overture *
Prep *▲
Presto *▲
Soliloquy *
Sonnet *
Trophy *
Uni-Form *

B continued
Petal Pusher *
Prairie *
Prim *
Radianc *
Ransom *
Roam *
Rush Hour *
Spree *
Summit *
Sutton *
Synth *
Tabloid *
Tinge *
Utmost *
Venue *
Versa *
Vinyl
Westwood *
Wide Angle *▲
Zipline *

C continued
Hudson *
Hula Hoop
Kaleidoscope CR
Lagos *
Legend CR *
Lore CR *
Magnolia *
Metro
Milestone *
Noble *
Palisade *
Panache CR
Pullman *
Quark *
Roundtrip *
Sahara
Sequin CR
Sinclair *
Smart *
Spectator *
Spot On *
Star Struck
Stepping Stones
Swing *
Tight Rope *
Tilden
Circa *
Tower Grid *
Treble CR
Wit *

D continued
Masquerade
Menagerie *
Origins *
Woodland *
Zoom

E
Aegean *
Cleo *
Demure
Highland *
Ikat Stripe *
Juno *
Katazome *
Kimono
Mamba
Marquee *
Meroe
Midpoint *
Nature Walk *
Sherman *
Shima *
Tryst *
Vatera *
Whip *

F continued
Soon *
Topography
Totem *
Tweed Frieze

G
Alter Ego
Arber *
Haze
Kamani *
Melange *
Modern Tweed *
Petite Floral *
Serendipity *
Spencer
Straie Stripe *
Ultrasuede *▲
Utrillo ▲

H
Arno *
Bavaria *
Catwalk *
Constance *
Firefly *
Magritte *
Stretch Appeal *

I
Aswan *
Byron *
Cato *
Cummings *
Diamond Days
Dynamic *
Ita *
Jaipur
Knoll Velvet *
Limani
North Island *
Olema *
Piper *
Rutledge *
Sandis
Tudor *
Vermeer *
Zimba *

U
Vicenza *▲
Volo *▲

V
Acqua *▲
Andes *▲
Embossed Tipped *
España *▲
Maremma ▲
Velluto Pelle *▲

W
Alaska *▲
Amazon *▲
Antique *▲
Forte *▲
Lucente
Sabrina *▲
▲ Approved for fully upholstered versions.
▲ Approved for Cal 133 upholstery.

X
Ducale *▲
Ducale Velour *▲

Y
Cervo *
Copenhagen *▲
Distressed *▲
Gemma
Lucca
Marissa *▲
Riva *▲
Torello

Approved for fully upholstered versions.
▲ Approved for Cal 133 upholstery.



Check with your KnollTextiles or Spinneybeck Representative for changes or additions.

Shelton Mindel

SM1 Lounge Collection

Designer(s):
Peter Shelton and Lee Mindel,
2006

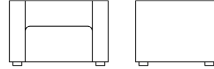

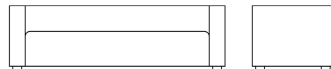
description	seat h	arm h	w	d	h	textile fabric yds.	leather sq. ft.	weight
SM1-1 SM1 Lounge chair	15 1/2"	25 1/2"	39"	32 1/4"	25 1/2"	6.5	80	83 lbs.
								
SM1-2 SM1 Settee	15 1/2"	25 1/2"	61 1/2"	32 1/4"	25 1/2"	9.0	120	96 lbs.
								
SM1-3 SM1 Sofa	15 1/2"	25 1/2"	85 1/2"	32 1/4"	25 1/2"	11.3	148	116 lbs.
								

Order Code	Ordering Information	Construction
<i>Example:</i> SM1-1-AOC-K349/1	<i>Leg finishes:</i> Clear Oak (suffix AOC) Ebonized (suffix AE) Polished Stainless Steel (suffix S)	<i>Frame:</i> Constructed in multi ply plywood with sinuous spring seat suspension and elastic webbing back suspension.
SM1-1 SM1 Lounge Chair	<i>Upholstery/COM information:</i> Prices shown include fabric or leather upholstery. Contact your Knoll representative for colors. Only approved KnollTextiles and Spinneybeck leathers may be ordered.	<i>Upholstery:</i> Seat and back cushions are continuous on all models.
AOC Clear Oak legs	Customer's Own Material is available pending approval. For approval requirements, processing instructions and ordering information please see page 18.	<i>Cushion fill:</i> Arm, seat and back cushions in variable density foam with Dacron wrap.
K349/1 Alignment, Sand		<i>Stitching:</i> Double-needled topstitching on leather upholstery. Double-needled topstitching on thin solid textiles, single-blind stitching on heavily ribbed fabrics and multicolor prints.
The SM1 lounge collection is part of a collection. Please refer to the Shelton Mindel side chair on page 272, SM2 lounge collection on page 276 and the SM table collection on page 398.		<i>Legs:</i> Round legs in Ash hardwood stained in Clear Oak, Ebonized or Polished Stainless Steel finish.
<i>Specify:</i> 1. Pattern number 2. Leg finish 3. Textile selection	<i>Cal 133 Fire Code:</i> The SM1 Lounge Collection complies with the California Technical Bulletin 133 standard if upholstered in Cal 133 approved upholstery. Specify suffix -C at end of pattern number and suffix -133 at end of textile selection. Upcharge applies, see page 19.	
	<i>Maintenance:</i> See pages 28-29.	

pattern no.	grades	COM	C	D	E	F	G	H	I	COL	U	V	W	X	Y
SM1-1-(-)(-)	\$4,450.	\$4,647.	\$4,834.	\$5,041.	\$5,211.	\$5,334.	\$5,541.	\$5,936.	\$6,226.	\$7,133.	\$7,738.	\$8,970.	\$9,227.	\$9,525.	

SM1-2-(-)(-)	6,645.	6,918.	7,179.	7,466.	7,700.	7,870.	8,156.	8,706.	9,107.	10,585.	11,495.	13,344.	13,726.	14,173.
---------------------	--------	--------	--------	--------	--------	--------	--------	--------	--------	---------	---------	---------	---------	---------

SM1-3-(-)(-)	7,848.	8,191.	8,520.	8,880.	9,173.	9,387.	9,747.	10,433.	10,940.	12,664.	13,786.	16,063.	16,536.	17,089.
---------------------	--------	--------	--------	--------	--------	--------	--------	---------	---------	---------	---------	---------	---------	---------

Approved KnollTextiles Grades/Fabrics				Spinneybeck Leather			
A Alignment # Beacon Bocce Cat's Cradle Chance Common Ground Commuter Cloth # Crossroad Delite Dristi Heavy Metal Hourglass Mariner Monarch # Overture Prep # Presto # Sonnet Trophy Uni-Form	B Argyle Belize Bistro # Calypso Cameo Chroma Chronicle Diva Ferry Gala II Helios Holbrook Journey Keaton Knoll Felt Knoll Hopsack Little Devil Ludlow Melody Paradigm Petal Pusher Pogo Prairie	C continued Prim Radiance Ransom Roam Rush Hour Spark # Spree Summit Sutton Synth Tabloid Tinge Venue Versa Vinyl Westwood Zipline	D continued Roundtrip Sahara Sequin CR Spot On Star Struck Swing Tight Rope Tilden Tower Grid Wit E Coterie Eclat Weave * Island Kabuki Menagerie Origins Woodland E Atlas Axiom Cairo Circa Classic Boucle Dahlia CR Decade Durand Earthwork # Enmesh # Entourage Essence Fibra Greenwich Hudson Kaleidoscope CR Kora CR Lagos Milestone Moto CR Palisade Panache CR * Pullman	E continued Marquee Meroe Nature Walk Tryst Whip F Atelier Biscayne Calais Cotton Velvet * Cornaro Glider Intrigue In Stitches Liberty Mod Plaid Rivington Soon Topography Totem Tweed Frieze * G Haze * Melange Modern Tweed Petite Floral Serendipity Spencer Ultrasuede #	H Arno Constance Firefly Magritte I Cato Diamond Days Dynamic Knoll Velvet * Olema Piper Rutledge Sandis Tudor Vermeer Zimba	U Vicenza # Volo # V Acqua # Andes # Embossed Tipped España # Velluto Pelle # W Alaska # Amazon # Antique # Derby # Forte # Lucente Sabrina # # not approved for Cal 133 upholstery. * Indicates fabrics without topstitching.	X Ducale # Ducale Velour # Y Cervo Copenhagen # Distressed # Marissa # Riva # Saddle #

Check with your KnollTextiles or Spinneybeck Representative for additions or changes.

Shelton Mindel

SM2 Lounge Collection

Designer(s):
Peter Shelton and Lee Mindel,
2006



description	seat h	arm h	w	d	h	type	textile	leather	weight
							fabric yds.	sq ft	
SM2-1 SM2 Lounge chair, same upholstery, frame and cushions	18 1/4"	24"	39 1/8"	35 1/4"	30 1/2"		8.3	124	56 lbs.
SM2-1 SM2 Lounge chair, combination upholstery, frame and cushions	18 1/4"		39 1/8"	35 1/4"	30 1/2"	frame uph.	5	76	
						upchg, cushions	4.25	56	

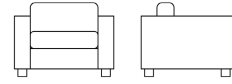

Order Code	Ordering Information	Construction
<i>Example:</i> SM2-2-S-K349/1	<i>Leg finishes:</i> Clear Oak (suffix AOC) Ebonized (suffix AE) Polished Stainless Steel (suffix S)	<i>Frame:</i> Constructed in 3/8" multi ply plywood with sinuous spring seat suspension and matrix back suspension.
SM2-2 SM2 Lounge Collection, settee		<i>Cushion fill:</i> Arm, seat and back cushions in variable density foams with Dacron wrap. The seat and back cushions are filled with memory foam.
S Stainless Steel legs		<i>Stitching:</i> Double needle top stitching on arms and back. Single needle top stitching on seat and back cushions in textile, double needle stitching for leather.
K349/1 Alignment, Sand	<i>Upholstery/ COM information:</i> Prices shown includes fabric or leather upholstery. Contact your Knoll representative for colors. Only approved KnollTextiles and Spinneybeck leathers may be ordered.	<i>Legs:</i> Round legs in Ash substrate with a Clear Oak, Ebonized or Polished Stainless Steel finish.
<i>Example:</i> SM2S-2-AE-VOBLK-K349/1	Customer's Own Material is available pending approval. For approval requirements, processing instructions and ordering information please see page 18.	
SM2-2 SM2 Lounge Collection, settee		
AE Ebonized legs		
VOBLK Surround in Volo, Black		
K349/1 Cushions in Alignment, Sand		

The SM2 lounge collection is part of a collection. Please refer to the Shelton Mindel side chair on page 272, SM1 lounge collection on page 274 and SM table collection on page 398.

Specify:

1. Pattern number
2. Leg finish
3. Textile selection

Specify with split upholstery:

1. Pattern number
2. Leg finish
3. Textile selection, Surround
4. Textile selection, Cushions

Cal 133 Fire Code:

The SM2 Lounge Collection complies with the California Technical Bulletin 133 standard if upholstered in Cal 133 approved upholstery. Specify suffix -C at end of pattern number and suffix -133 at end of textile selection. Upcharge applies, see page 19.

Maintenance:
See pages 28-29.

pattern no.	grades	COM	C	D	E	F	G	H	I	COL	V	W	X	Y
SM2-1-(-)(-)	\$5,735.	\$5,989.	\$6,226.	\$6,494.	\$6,708.	\$6,865.	\$7,131.	\$7,636.	\$8,006.	\$9,773.	\$10,709.	\$12,637.	\$13,019.	\$13,477.
SM2S-1-(-)(-)(-)	4,591.	4,775.	4,946.	5,140.	5,294.	5,408.	5,598.	5,963.	6,236.	6,744.	7,321.	8,492.	8,737.	9,019.
upchg, cushions	1,689.	1,818.	1,941.	2,077.	2,186.	2,269.	2,402.	2,662.	2,853.	3,287.	3,711.	4,575.	4,753.	4,962.

Approved KnollTextiles Grades/Fabrics

A Alignment ‡ Beacon Bocce Cat's Cradle Chance Common Ground Commuter Cloth ‡ Crossroad Delite Dristi Heavy Metal Hourglass Mariner Monarch ‡ Overture Prep ‡ Presto ‡ Sonnet Trophy Uni-Form	B continued Knoll Hopsack Little Devil Ludlow Melody Paradigm Petal Pusher Pogo Prairie Prim Radiance Ransom Roam Rush Hour Spark ‡ Spree Summit Sutton Synth Tabloid Tinge Venue Versa Vinyl Westwood Zipline	C continued Enmesh ‡ Entourage Essence Fibra Greenwich Hudson Hula Hoop Kaleidoscope CR Kora CR Lagos Metro Milestone Moto CR Palisade Panache CR * Pullman Roundtrip Sahara Sequin CR Spot On Star Struck Stepping Stones Swing Tight Rope Tilden Tower Grid Wit Zari CR	D continued Menagerie Origins Woodland E Aegean Demure Highland Ikata Stripe Katazome Mamba Marquee Meroe Nature Walk Shima Meroe Tryst Whip F Atelier Biscayne Calais Cotton Velvet * Cornaro Glider Icon * Intrigue In Stitches Liberty Mod Plaid Rivington	F continued Soon Topography Totem Tweed Frieze * G Haze * Melange Modern Tweed Petite Floral Serendipity Spencer Ultrasuede ‡ H Arno Constance Firefly Magritte I Cato * Diamond Days Dynamic Knoll Velvet * Olema Piper Rutledge Sandis Tudor Vermeer Zimba
--	--	--	--	---

Spinneybeck Leather

U Vicenza ‡ Volo ‡	X Ducale ‡ Ducale Velour ‡
V Acqua ‡ Andes ‡ Embossed Tipped España ‡ Velluto Pelle ‡	Y Cervo Copenhagen ‡ Distressed ‡ Marissa ‡ Riva ‡ Saddle ‡
W Alaska ‡ Amazon ‡ Antique ‡ Derby ‡ Forte ‡ Lucente Sabrina ‡ Umbria	‡ Approved for Cal 133 upholstery. * Indicates fabrics without topstitching.

Check with your KnollTextiles or Spinneybeck Representative for additions or changes.

Shelton Mindel

SM2 Lounge Collection

Designer(s):
Peter Shelton and Lee Mindel,
2006



description	seat h	arm h	w	d	height	type	textile fabric yds.	leather sq ft	weight
SM2-2 SM2 Settee, same upholstery, frame and cushions	18 1/4"	24"	60 1/2"	35 1/4"	30 1/2"		13.25	168	77 lbs.
SM2-2 SM2 Settee, combination upholstery, frame and cushions	18 1/4"		60 1/2"	35 1/4"	30 1/2"	frame uph.	7.5	104	
						upchg, cushions	7.5	80	
SM2-3 SM2 Sofa, same upholstery, frame and cushions	18 1/4"	24"	84 1/2"	35 1/4"	30 1/2"		19.5	208	108 lbs.
SM2-3 SM2 Sofa, combination upholstery, frame and cushions	17 3/4"		93 1/2"	36 1/2"	29"	frame uph.	9.5	128	
						upchg, cushions	11.25	104	

Order Code	Ordering Information	Construction
<i>Example:</i> SM2-2-S-K349/1	<i>Leg finishes:</i> Clear Oak (suffix AOC) Ebonized (suffix AE) Polished Stainless Steel (suffix S)	<i>Frame:</i> Constructed in 3/8" multi ply plywood with sinuous spring seat suspension and matrix back suspension.
SM2-2 SM2 Lounge Collection, settee		<i>Cushion fill:</i> Arm, seat and back cushions in variable density foams with Dacron wrap. The seat and back cushions are filled with memory foam.
S Stainless Steel legs		<i>Stitching:</i> Double needle top stitching on arms and back. Single needle top stitching on seat and back cushions in textile, double needle stitching for leather.
K349/1 Alignment, Sand	<i>Upholstery/ COM information:</i> Prices shown includes fabric or leather upholstery. Contact your Knoll representative for colors. Only approved KnollTextiles and Spinneybeck leathers may be ordered.	<i>Legs:</i> Round legs in Ash substrate with a Clear Oak, Ebonized or Polished Stainless Steel finish.
<i>Example:</i> SM2S-2-AE-VOBLK-K349/1	Customer's Own Material is available pending approval. For approval requirements, processing instructions and ordering information please see page 18.	
SM2-2 SM2 Lounge Collection, settee		
AE Ebonized legs		
VOBLK Surround in Volo, Black		
K349/1 Cushions in Alignment, Sand		

The SM2 lounge collection is part of a collection. Please refer to the Shelton Mindel side chair on page 272, SM1 lounge collection on page 274 and SM table collection on page 398.

Specify:

1. Pattern number
2. Leg finish
3. Textile selection

Specify with split upholstery:

1. Pattern number
2. Leg finish
3. Textile selection, Surround
4. Textile selection, Cushions

Cal 133 Fire Code:

The SM2 Lounge Collection complies with the California Technical Bulletin 133 standard if upholstered in Cal 133 approved upholstery. Specify suffix -C at end of pattern number and suffix -133 at end of textile selection. Upcharge applies, see page 19.

Maintenance:
See pages 28-29.

pattern no.	grade	COM	C	D	E	F	G	H	I	COL	V	W	X	Y
SM2-2-(-)(-)	\$8,589.	\$8,991.	\$9,375.	\$9,797.	\$10,142.	\$10,391.	\$10,816.	\$11,619.	\$12,214.	\$13,892.	\$15,163.	\$17,751.	\$18,288.	\$18,913.
SM2S-2-(-)(-)(-)	6,737.	6,979.	7,211.	7,467.	7,675.	7,826.	8,080.	8,568.	8,927.	9,699.	10,486.	12,088.	12,419.	12,810.
upchg, cushionsS	2,522.	2,749.	2,965.	3,204.	3,400.	3,540.	3,781.	4,237.	4,575.	4,723.	5,327.	6,559.	6,816.	7,115.
SM2-3-(-)(-)	11,113.	11,707.	12,272.	12,894.	13,401.	13,769.	14,393.	15,578.	16,453.	17,547.	19,122.	22,324.	22,991.	23,765.
SM2S-3-(-)(-)(-)	8,693.	9,044.	9,377.	9,743.	10,043.	10,260.	10,628.	11,326.	11,844.	12,246.	13,216.	15,186.	15,596.	16,072.
upchg, cushionsSO	3,312.	3,652.	3,979.	4,341.	4,632.	4,844.	5,201.	5,885.	6,392.	6,090.	6,878.	8,478.	8,812.	9,200.

Approved KnollTextiles Grades/Fabrics

A Alignment ‡ Beacon Bocce Cat's Cradle Chance Common Ground Commuter Cloth ‡ Crossroad Delite Dristi Heavy Metal Hourglass Mariner Monarch ‡ Overture Prep ‡ Presto ‡ Sonnet Trophy Uni-Form	B continued Knoll Hopsack Little Devil Ludlow Melody Paradigm Petal Pusher Pogo Prairie Prim Radiance Ransom Roam Rush Hour Spark ‡ Spree Summit Sutton Synth Tabloid Tinge Venue Versa Vinyl Westwood Zipline	C continued Enmesh ‡ Entourage Essence Fibra Greenwich Hudson Hula Hoop Kaleidoscope CR Kora CR Lagos Metro Milestone Moto CR Palisade Panache CR * Pullman Roundtrip Sahara Sequin CR Spot On Star Struck Stepping Stones Swing Tight Rope Tilden Tower Grid Wit Zari CR	D continued Menagerie Origins Woodland E Aegean Demure Highland Ikata Stripe Katazome Mamba Marquee Meroe Nature Walk Shima Meroe Tryst Whip F Atelier Biscayne Calais Cotton Velvet * Cornaro Glider Icon * Intrigue In Stitches Liberty Mod Plaid Rivington	F continued Soon Topography Totem Tweed Frieze * G Haze * Melange Modern Tweed Petite Floral Serendipity Spencer Ultrasuede ‡ H Arno Constance Firefly Magritte I Cato * Diamond Days Dynamic Knoll Velvet * Olema Piper Rutledge Sandis Tudor Vermeer Zimba
--	--	--	--	---

Spinneybeck Leather

U Vicenza ‡ Volo ‡	X Ducale ‡ Ducale Velour ‡
V Acqua ‡ Andes ‡ Embossed Tipped España ‡ Velluto Pelle ‡	Y Cervo Copenhagen ‡ Distressed ‡ Marissa ‡ Riva ‡ Saddle ‡
W Alaska ‡ Amazon ‡ Antique ‡ Derby ‡ Forte ‡ Lucente Sabrina ‡ Umbria	‡ Approved for Cal 133 upholstery. * Indicates fabrics without topstitching.





Check with your KnollTextiles or Spinneybeck Representative for additions or changes.

Kazuhide Takahama

Suzanne Lounge Seating

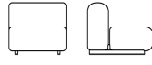
Designer(s):
Kazuhide Takahama, 1965

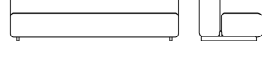
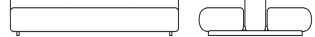

description	seat h	w	d	h	textile fabric yds.	weight
53S1 Lounge chair 	14 1/2"	30 1/2"	35"	27"	3.4	53 lbs.
53D1 Double lounge chair 	14 1/2"	30 1/2"	59"	27"	4.6	79 lbs.
53S2 Settee 	14 1/2"	60"	35"	27"	6.8	98 lbs.
53D2 Double Settee 	14 1/2"	60"	59"	27"	8.7	150 lbs.
53S3 Sofa 	14 1/2"	83"	35"	27"	10.2	146 lbs.
53D3 Double Sofa 	14 1/2"	83"	59"	27"	12.4	225 lbs.

pattern no.	Base Grade	grades A	COM B	C	D	E	F	G	H	I
53S1	\$1,986.	\$2,429.	\$2,510.	\$2,601.	\$2,708.	\$2,856.	\$2,941.	\$3,093.	\$3,193.	\$3,493.
53D1	3,255.	3,741.	3,856.	3,986.	4,140.	4,353.	4,478.	4,697.	4,841.	5,273.
53S2	3,454.	4,068.	4,215.	4,379.	4,574.	4,844.	5,001.	5,277.	5,459.	6,006.
53D2	5,494.	6,297.	6,504.	6,735.	7,009.	7,387.	7,609.	7,994.	8,250.	9,019.
53S3	5,423.	6,324.	6,537.	6,776.	7,060.	7,452.	7,679.	8,079.	8,345.	9,138.
53D3	8,496.	9,718.	10,012.	10,342.	10,732.	11,272.	11,586.	12,137.	12,503.	13,598.

Order Code

<i>Example:</i>	53S1-K134/21
53S1	Suzanne lounge chair
K134/21	Bank Shot, Thyme

Specify:

1. Pattern number
2. Textile selection

Ordering Information

Upholstery/COM information:
Prices shown include fabric or leather upholstery. Contact your KnollStudio representative for colors.

Customer's Own Material is available pending approval. For approval requirements, processing instructions and ordering information please see page 18.

Maintenance:
See pages 28-29.

Notes:
The Suzanne Lounge Seating is Greenguard certified.

Split upholstery back and seat:
The Suzanne Lounge Collection may be specified with split upholstery for **KnollTextiles ONLY**, where the horizontal seat module and the vertical back module are upholstered in different textiles. Indicate B before selected back upholstery, followed by the selected seat upholstery. Price equals the higher upholstery grade.

Note:
Split upholstery with base grade textiles or a combination of KnollTextiles and base grade textiles must be requested through Custom Product Development.

COM split fabric requirements:
53S1 seat: 1.6 yards
53S1 back: 1.8 yards
53D1 seat: 3.2 yards
53D1 back: 1.8 yards
53S2 seat: 2.7 yards
53S2 back: 2.8 yards
53D2 seat: 4.4 yards
53D2 back: 2.8 yards
53S3 seat: 3.7 yards
53S3 back: 4 yards
53D3 seat: 7.4 yards
53D3 back: 4 yards

Split upholstery side panel and main body:
The Suzanne Lounge Collection may be specified with split upholstery, where the side panels and the main body are upholstered in different textiles. Indicate P before selected side panel upholstery, followed by the selected main body upholstery. Price equals the higher upholstery grade.

COM split fabric requirements:
53S1 side: 0.9 yards
53S1 main: 2.7 yards
53D1 side: 1.2 yards
53D1 main: 3.6 yards
53S2 side: 0.9 yards
53S2 main: 4.6 yards
53D2 side: 1.2 yards
53D2 main: 6.2 yards
53S3 side: 0.9 yards
53S3 main: 6.7 yards
53D3 side: 1.2 yards
53D3 main: 8.9 yards

Construction

Frame:
Aluminum extrusion, polished aluminum end caps and top edge. Brushed aluminum sides. Comes with plastic glides

Upholstery:
Separate high-resilient Cal 117 foam cushions with MDF seat and back supports structure.

Base Grade Textile

Fabric, Base Grade:
Green Tea (suffix KLF01)
Heirloom Tomato (suffix KLF02)
Blue Moon (suffix KLF03)
Earl Grey (suffix KLF04)
Chocolate Stout (suffix KLF05)
Black Tea (suffix KLF06)

Approved KnollTextiles Grades/Fabrics

A Common Ground Delite Dristi Hourglass Mariner Presto * Sonnet Uni-Form	C Classic Boucle Dune Entourage Noble Palisade Pullman Smart Spot On Swing * Tilden	G Melange Modern Tweed Ultrasuede
B Calypso Diva Ferry Journey Knoll Felt Knoll Hopsack Little Devil Prairie Summit Synth Venue Westwood	E Aegean Cleo Highland Marquee Vatera Whip	H Bavaria Firefly Magritte Stretch Appeal
	F Atelier Calais Cotton Velvet Comaro Intrigue In Stitches Tweed Frieze	I Dynamic Knoll Velvet Tudor

* Fabric will be railroaded

Check with your KnollTextiles representative for changes or additions.



Ufficio Tecnico Spoleto Chair

Designer(s):
Ufficio Tecnico, 1971

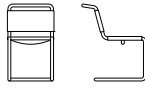

description	seat h	w	d	h	weight
50CS Spoleto armless chair	18"	18½"	23½"	32"	17 lbs.
					
50KIT Replacement sling kit with nylon laces, cowhide					
50KIT Replacement sling kit with nylon laces, belting leather					
50LACE Replacement nylon laces for cowhide, belting leather and hair hide slings					

pattern no.	
50CS-() 	\$2,100.
50KIT-L ()	945.
50KIT-(BL, HH) ()	945.
50LACE-(L, BL, HH)-()	90.

Order Code	Ordering Information
<i>Example:</i> 50CS-BL1901	
50CS Spoleto armless chair	<i>Spinneybeck Belting Leather:</i>  Black (suffix BLBLCK) Chocolate (suffix BL1902) Cognac (suffix BL1904) Dark Mustard (suffix BL1903) Dark Salmon (suffix BL1906) Deep Blue (suffix BL1912) Deep Green (suffix BL1911) Deep Purple (suffix BL1913) Fudge (suffix BL1901) Key Lime (suffix BL1910) Lemon Meringue (suffix BL1909) Simply Red (suffix BL1905) Sunshine (suffix BL1908) Sweet Potato (suffix BL1907) White (suffix BL1914)
BL1901 Belting leather, Fudge	<i>Haired Hide:</i> Black (BLCKHH) Black and White (BKWHHH) Chestnut (suffix OA12HH) Coffee (suffix O18HH) Gold (suffix OCP5HH) Mahogany (suffix OA19HH) Tan (suffix OCP3HH) Tri-Color (3COLHH)
<i>Specify:</i>	<i>Upholstery/COM information:</i> Prices shown include leather upholstery. Customer's Own Material is not available.  <i>KnollStudio 20-day Program:</i> The Spoleto chair is available on the 20-day program in black belting leather. For more information, consult pages 30-33. <i>Maintenance:</i> See pages 28-29. <i>Note:</i> Please ask your Spinneybeck Representative for samples of the belting leather and haired hide.
	<i>Cowhide selection:</i> Black (suffix L80) Light Brown (suffix L82) White Beige (suffix L84)



Construction
<i>Frame:</i> Seamless tubular steel in polished chrome finish.
<i>Upholstery:</i> <i>Cowhide Slings:</i> Thick cowhide leather slings in three colors. Edges dyed to match for Black and Light Brown colors. White Beige will have edges matching Light Brown cowhide color.
<i>Belting Leather:</i> Highly durable Spinneybeck belting leather in fifteen colors. Belting leather edges will always match specified color.
<i>Haired Hide:</i> Spinneybeck haired hide in eight colors. Haired Hide is a natural material, markings are one-of-a-kind and will vary from piece to piece.
<i>Laces:</i> Nylon laces are dyed to match specified leather. Haired hide and belting leather option will have nylon laces.
<i>Glides:</i> Four molded clear plastic glides with twin-pin snap-in construction included with all Spoleto chairs.
<i>Replacement Slings:</i> Slings can be replaced in the field by field services or a furniture repair specialist. Kit includes back and seat replacement slings with nylon laces. Slings should be fitted by field services or by a professional upholsterer.

Vignelli Associates

Handkerchief Armless Chair

Designer(s):
Vignelli Designs, 1983

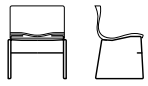

description	seat h	w	d	h	textile fabric yds.	weight
4901 Armless chair, unupholstered shell	18"	23"	22 1/2"	29"		21 lbs.
						
4901K-N Armless chair, seat pad, non-stacking	18"	23"	22 1/2"	29"	0.7	23 lbs.
						
4901K-S Armless chair, seat pad, stacking	18"	23"	22 1/2"	29"	0.7	23 lbs.
						
49100D Stacking dolly		24 3/8"	26"	12"		10 lbs.
G Optional glides						

Order Code	Ordering Information	Construction
<i>Example:</i> 4901-W-C	<i>Shell colors:</i> Black (suffix B) Grey (suffix G) Midnight (MD) Red (suffix R) White (suffix W)	Customer's Own Material is available pending approval. For approval requirements, processing instructions and ordering information please see page 18.
4901	<i>Base finishes:</i> Polished Chrome (suffix C)	<i>Shell:</i> Compression-molded. Highly durable fiberglass reinforced polyester; with urethane paint finish.
W	<i>Upholstery/COM information:</i> Prices shown include fabric upholstery. Contact your Knoll representative for colors. Only approved KnollTextiles and Spinneybeck leathers may be ordered.	<i>Seat pad:</i> High-resilience polyurethane cushion bonded to a semi-rigid thermoformed support.
C		<i>Base:</i> 7/16" steel wire finished in brightly polished chrome.
		<i>Optional glides:</i> Nylon. (Add -G to end of pattern number)
		<i>Stacking bumper:</i> Black flexible urethane stacking pad secured between base and shell.
		<i>Maintenance:</i> See pages 28-29.
		<i>Note:</i> The Handkerchief Armless Chair is Greenguard certified.

Note:
The Vignelli Handkerchief side chairs are part of a collection. Please refer to Vignelli PaperClip Tables on page 406.

- Specify:
1. Pattern number
 2. Shell color selection
 3. Base finish selection
 4. Glide option
 5. Cal 133 Fire Code option for seat pad
 6. Textile selection for seat pad

pattern no.	grades	COM	C	D	E	F	G	H	I
4901-(-)C									
4901K-N-(-)C-(-)	1,193.	1,216.	1,243.	1,267.	1,291.	1,309.	1,333.	1,386.	1,424.
4901K-S-(-)C-(-)	1,238.	1,262.	1,288.	1,312.	1,333.	1,351.	1,378.	1,428.	1,466.
49100D	1,754.								
G	31.								

Approved KnollTextiles Grades/Fabrics					
<i>Stacking features:</i> 4901 and 4901K-S chairs stack 15-20 high. Chairs without stacking bumper (4901K-N) do not stack.	A Alignment Beacon Bocce Cat's Cradle Chance Common Ground # Commuter Cloth Crossroad Delite Hourglass Monarch Overture Prep Soliloquy Sonnet Trophy Uni-Form	B continued Prairie Prim # Radiance Ransom Roam Rush Hour Spark Spree Summit Sutton Synth Tabloid Tinge Venue Versa Westwood Wide Angle	C continued Kaleidoscope CR Kaya CR Lagos Legend CR Lore CR Magnolia Milestone Noble Palisade Pullman Regard CR Roundtrip Sinclair Smart Spectator Spot On Stepping Stones Tight Rope Tilden Tower Grid Treble CR Wit	D Compass CR Coterie Eclat Weave In The Loop Island Kabuki Masquerade Menagerie Origins Woodland	E Aegean Cleo Demure Highland Ikat Stripe Juno Katazome Kimono Marquee Meroe Midpoint Nature Walk Sherman Tryst Vatera Whip
	B Argyle Belize Bistro Calypso Cameo Chroma # Chronicle Close Knit Diva Dovetail Ferry Gala II Grandview Helios Holbrook Journey Knoll Felt Knoll Hopsack Little Devil Ludlow Melody Mini Stitch Paradigm Petal Pusher Pogo #	C Atlas Axiom Baxter Cairo Circa Classic Boucle Dahlia CR Decade Dune Durand Enmesh Entourage Essence Fable CR Fibra Greenwich Hudson Hula Hoop	D Compass CR Coterie Eclat Weave In The Loop Island Kabuki Masquerade Menagerie Origins Woodland	E Atelier Biscayne Cornaro Glider Intrigue In Stitches Liberty Mod Plaid Rivington Soon Topography Tweed Frieze	F Alter Ego Andissa Arber Gibson Kamani Melange Modern Tweed Serendipity Straie Stripe Ultrastuede Utrillo
					G Alter Ego Andissa Arber Gibson Kamani Melange Modern Tweed Serendipity Straie Stripe Ultrastuede Utrillo
					H Arno Bavaria Catwalk Constance Firefly Magritte Stretch Appeal
					I Aswan Byron Cato Cummings Diamond Days Dynamic Ita Jaipur Mepal Olema Piper Sandis Tudor Vermeer Zimba
					# Approved for Cal 133 upholstery.
					Check with your KnollTextiles representative for changes or additions.

Vignelli Associates
Handkerchief Arm Chair

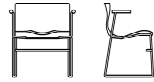
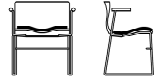
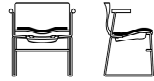
	description	seat h	arm h	w	d	h	textile fabric yds.	weight
<i>Designer(s):</i> Vignelli Designs, 1983	4902 Arm chair, unupholstered shell	18"	26"	26"	22 1/2"	29"		24 lbs.
								
	4902K-N Arm chair, seat pad, non-stacking	18"	26"	26"	22 1/2"	29"	0.7	26 lbs.
								
	4902K-S Arm chair, seat pad, stacking	18"	26"	26"	22 1/2"	29"	0.7	26 lbs.
								
	49100D Stacking dolly			24 3/8"	26"	12"		10 lbs.
	G Glides (add -G to end of pattern number)							

Order Code	Ordering Information	Construction
<i>Example:</i> 4902-MD-C	<i>Shell colors:</i> Black (suffix B) Grey (suffix G) Midnight (MD) Red (suffix R) White (suffix W)	<i>Shell:</i> Compression-molded. Highly durable fiberglass reinforced polyester; with urethane paint finish.
4902 Handkerchief unupholstered arm chair	<i>Base finishes:</i> Polished Chrome (suffix C)	<i>Seat pad:</i> High-resilience polyurethane cushion bonded to a semi-rigid thermoformed support.
MD Midnight shell	<i>Upholstery/COM information:</i> Prices shown include fabric upholstery. Contact your Knoll representative for colors. Only approved KnollTextiles and Spinneybeck leathers may be ordered.	<i>Base:</i> 7/16" steel wire finished in brightly polished chrome.
C Chrome frame		<i>Optional glides:</i> Nylon. (Add -G to end of pattern number)
		<i>Stacking bumper:</i> Black flexible urethane stacking pad secured between base and shell.
	<i>Maintenance:</i> See pages 28-29.	
	<i>Note:</i> The Handkerchief Arm Chair is Greenguard certified.	

Note:
The Vignelli Handkerchief side chairs are part of a collection. Please refer to Vignelli PaperClip Tables on page 406.

- Specify:
1. Pattern number
 2. Shell color selection
 3. Base finish selection
 4. Glide option
 5. Cal 133 Fire Code option for seat pad
 6. Textile selection for seat pad



pattern no.	grades	COM	C	D	E	F	G	H	I
4902(-)C									
	\$1,024.								
4902K-N(-)C(-)	1,348.	1,371.	1,395.	1,423.	1,445.	1,462.	1,471.	1,539.	1,577.
4902K-S(-)C(-)	1,388.	1,413.	1,437.	1,465.	1,487.	1,503.	1,530.	1,580.	1,618.
49100D	1,754.								
G [4902]	31.								

Approved KnollTextiles Grades/Fabrics					
<i>Stacking features:</i> 4902 and 4902K-S chairs stack 15-20 high. Chairs without stacking bumper (4902K-N) do not stack.	A Alignment Beacon Bocce Cat's Cradle Chance Common Ground [‡] Commuter Cloth Crossroad Delite Hourglass Monarch Overture Prep Soliloquy Sonnet Trophy Uni-Form	B continued Prairie Prim [‡] Radiance Ransom Ricochet Roam Rush Hour Soiree Spark Spree Summit Sutton Synth Tabloid Tinge Venue Versa Westwood Wide Angle	C continued Kaleidoscope CR Lagos Legend CR Lore CR Magnolia Milestone Noble Palisade Pullman Regard CR Roundtrip Sinclair Smart Spectator Spot On Stepping Stones Tight Rope Tilden Tower Grid Treble CR Wit	E Aegean Cleo Demure Highland Ikat Stripe Juno Katazome Kimono Marquee Meroe Midpoint Nature Walk Sherman Tryst Vatera Whip	G Abington Alter Ego Andissa Arabella Arber Garden City Gibson Kamani Kingston Melange Modern Tweed Sablon Serendipity Straie Stripe Ultrasuede Utrillo
	B Argyle Belize Bistro Calypso Cameo Chroma [‡] Chronicle Close Knit Diva Dovetail Ferry Gala II Grandview Helios Holbrook Journey Knoll Felt Knoll Hopsack Little Devil Ludlow Lyric Melody Mini Stitch Paradigm Petal Pusher Pogo [‡]	C Atlas Axiom Baxter Biota Cairo Circa Classic Boucle Dahlia CR Decade Dune Durand Enmesh Entourage Essence Fable CR Fibra Greenwich Hudson Hula Hoop	D Compass CR Coterie Eclat Weave In The Loop Island Masquerade Menagerie Origins Theory Woodland	F Atelier Biscayne Cornaro Glider Intrigue In Stitches Liberty Mod Plaid Rivington Soon Topography Tweed Frieze	H Arno Bavaria Catwalk Constance Firefly Gezelle Magritte Stretch Appeal
				I Aswan Byron Canaan Cato Cummings Diamond Days Dynamic Fiori Ita Jaipur Mepal Olema Piper Ravello Sandis Tudor Vermeer Walker Worth Zimba	

[‡] Approved for Cal 133 upholstery.

Check with your KnollTextiles representative for changes or additions.

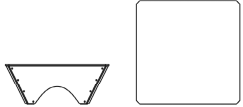
David Adjaye
The Washington Collection for Knoll™
 Corona™ Coffee Table

	description	w	d	h	base	weight
Designer(s): David Adjaye, 2013 	WC1T Washington Corona™ bronze coffee table	40 3/4"	40 3/4"	15 3/4"	Bronze	450 lbs.
						
	WC2T Washington Corona™ aluminum coffee table, black painted	40 3/4"	40 3/4"	15 3/4"	Aluminum	170 lbs.
						

pattern no	clear glass
WC1T	\$110,334.
WC2T	9,654.

Order Code	Ordering Infomation	Construction
Example: WC2T WC2T Aluminum coffee table, black painted	Glass finish: Clear glass Maintenance: See pages 28-29.	Clear glass top: Top is 1/2" thick optically clear glass with a jewel-polished, chamfered edge. Bronze base: Constructed from four sand-cast bronze panels, connected by machined bronze plates and brass hardware. The interior of the panels are CNC-machined and hand-polished to a mirror finish, contrasting the rough hewn exterior. Aluminum base: Constructed from four die-cast aluminum panels, connected by aluminum connector plates and stainless steel hardware. The interior of the panels are finished in a smooth gloss black powder coat paint, contrasting the matte textured black powder coat paint exterior.
Specify: 1. Pattern number		Note: To mark our 75th anniversary, the Washington Corona coffee table in bronze is limited to an edition of 75. Each piece is numbered and comes with a commemorative signature plate. The Washington Corona coffee table is Greenguard certified.

David Adjaye
The Washington Collection for Knoll™
Prism™ Side Table

	description	w	d	h
<i>Designer(s):</i> David Adjaye, 2014	WL25T Side table	17"	14½"	18"

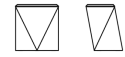

Award(s):
 Editors Choice Award, Lounge Furniture Collection, NeoCon June 2015, USA; MetropolisLikes Award, Metropolis Magazine, June 2015, USA



pattern no	MA, MAS, GG, GGS, MN, MNS	MC, MCS	MV, MVS
WL25T-()-()	\$7,823.	\$8,115.	\$8,249.

Order Code

<i>Example:</i> WL25T-118G-MCS
WL25T Side table
118G White base
MCS Satin Calacatta

Ordering Information

Base finishes:
 Black (suffix 111G)
 White (suffix 118G)
 Red (suffix 845G)



Polished Coated marble top finishes:
 Arabescato: white-grey (suffix MA)
 Calacatta: white-grey/beige (suffix MC)
 Grey Marble: light grey (suffix GG)
 Nero Marquina: black (suffix MN)
 Verdi Alpi: green (suffix MV)

- Specify:*
1. Pattern number
 2. Base finish selection
 3. Marble selection

Satin Coated marble top finishes:
 Arabescato: white-grey (suffix MAS)
 Calacatta: white-grey/beige (suffix MCS)
 Grey Marble: light grey (suffix GGS)
 Nero Marquina: black (suffix MNS)
 Verdi Alpi: green (suffix MVS)

Maintenance:
 See pages 28-29.

Franco Albini
Albini Desk

	description	w	d	h	weight
<p><i>Designer(s):</i> Franco Albini, 1938</p> 	<p>80D Pedestal desk</p> 	48"	26"	27 1/2"	95 lbs.

pattern no.	
80D-(E, L2) 	\$6,364.

Order Code

<i>Example:</i> 80D-E
80D Albini desk
E Ebonized Oak pedestal

Specify:

1. Pattern number
2. Pedestal finish

Ordering Information

Albini pedestal finishes:
 Ebonized Oak (suffix E)
 White Lacquer (suffix L2)

 *20-Day:*
 The Albini desk in ebonized oak finish is available on the KnollStudio 20-Day program. For specific information consult pages 30-33.

Maintenance:
 See pages 28-29.

Construction

Base:
 Frame and legs in square steel tube with chrome finish.

Top:
 1/2" clear tempered glass.

Pedestal:
 2 drawer "floating" wood pedestal. Rear open shelf for magazines or small books.

Pedestal dimensions:
 16 1/2" w x 26" d x 8 1/4" h

Drawer dimensions:
 14 1/8" w x 14 1/8" d x 2 1/2" h

Rear shelf dimensions:
 15 1/2" w x 8 1/2" d x 7" h

Drawer mounts only on the right side.

Edward Barber & Jay Osgerby
Piton™ Side Table

description	w	d	h	top finish	weight
BO21T side table	16 1/4"	16 1/4"	21 1/4"	Ash	16 lbs.
	16 1/4"	16 1/4"	21 1/4"	Teak	16 lbs.

Designer(s):
 Edward Barber and Jay Osgerby,
 2014

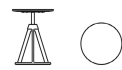

pattern no.	list
BO21T-AE-()	\$1,066.
BO21T-K-()	1,340.

Order Code

<i>Example:</i>	BO21T-K-WHTT
BO21T	Side Table
K	Teak
WHTT	White

Specify:

1. Pattern number
2. Top selection
3. Base selection

Ordering Information

Wood Top Finishes:
 Ebonized Ash (suffix AE)
 Teak, natural (suffix K)

Base Paint Finishes:
 Jet Black (suffix 111T)
 Medium Metallic Grey (suffix 612T)
 Red Coral (suffix CRLT)
 Sterling (suffix 906T)
 White (suffix WHTT)

Maintenance:
 See pages 28-29.



Construction

Base:
 Base is constructed of die-cast aluminum with stainless steel fasteners and finished with a highly durable powder coat in a variety of colors.

Wood Tops:
 Knife edge wood tops are available in ebonized ash or an oiled teak.

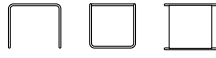
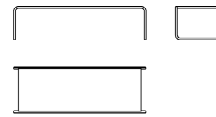
Marcel Breuer
Laccio Tables

	description	w	d	h	weight
<p><i>Designer(s):</i> Marcel Breuer, 1924</p> 	<p>50T1 Laccio side table</p> 	21 3/4"	19"	17 3/4"	13 lbs.
	<p>50T2 Laccio coffee table</p> 	53 1/2"	19"	13 1/2"	29 lbs.

pattern no.	
50T1-() 	\$932.
50T2-() 	1,319.

Order Code





<i>Example:</i> 50T1-F1
50T1 Laccio side table
F1 Black Laminate

Note:
Laccio tables are part of a collection. Please refer to the Cesca and Wassily chairs on pages 94 and 98.

Specify:

1. Pattern number
2. Top finish selection

Ordering Information

Top finishes:
 Black (suffix F1)
 Red (suffix F3)
 White (suffix F2)
 *KnollStudio 20-Day Program:*
 Laccio tables in black and white laminates are available on the 20-day program. For specific information, consult pages 30-33.

Maintenance:
See pages 28-29.

Note:
The KnollStudio logo and signature of Marcel Breuer is stamped into the base of the table.



Construction

Top:
Satin finish, smooth plastic laminate.

Base:
Frame and legs seamless tubular steel in polished chrome finish.

Joseph Paul D’Urso







Square Work and Low Tables

description	width between legs	w	d	h, work tables	h, low tables	weight	top
6348 Square table, medium 	22 1/2"	48"	48"	27 1/2"	15 1/4"	130 lbs.	laminate
	22 1/2"	48"	48"	27 1/2"	15 1/4"	128 lbs.	figured techgrain®
	22 1/2"	48"	48"	27 1/2"	15 1/4"	128 lbs.	natural veneer
	22 1/2"	48"	48"	27 1/2"	15 1/4"	197 lbs.	natural marble
	22 1/2"	48"	48"	27 1/2"	15 1/4"	197 lbs.	coated marble
6354 Square table, medium 	25 1/8"	54"	54"	27 1/2"	15 1/4"	145 lbs.	laminate
	25 1/8"	54"	54"	27 1/2"	15 1/4"	141 lbs.	figured techgrain®
	25 1/8"	54"	54"	27 1/2"	15 1/4"	141 lbs.	natural veneer
	25 3/8"	54"	54"	27 1/2"	15 1/4"	241 lbs.	natural marble
	25 1/8"	54"	54"	27 1/2"	15 1/4"	241 lbs.	coated marble
	25 1/8"	54"	54"	27 1/2"	15 1/4"	281 lbs.	granite
6360 Square table, large 	25 1/8"	60"	60"	27 1/2"	15 1/4"	183 lbs.	laminate
	25 1/8"	60"	60"	27 1/2"	15 1/4"	179 lbs.	figured techgrain®
	25 1/8"	60"	60"	27 1/2"	15 1/4"	179 lbs.	natural veneer
	25 1/8"	60"	60"	27 1/2"	15 1/4"	288 lbs.	natural marble
	25 1/8"	60"	60"	27 1/2"	15 1/4"	288 lbs.	coated marble
	25 1/8"	60"	60"	27 1/2"	15 1/4"	338 lbs.	granite
GL Glides							
C Casters							
CX Locking casters							

Designer(s):
Joseph Paul D’Urso, 1980

Award(s):
Design Center Stuttgart Award, W. Germany, 1983; Federal Award for Industrial Design, W. Germany, 1983



Order Code	Ordering Information
<i>Example:</i> 6354L-C-111-C	
6354 54" square table	<i>Laminate top finishes:</i>  Bright White (suffix 118)  Fog (suffix 128)  Jet Black (suffix 111)  Light Grey (suffix L)  Pumice (suffix 119)
L Low height	<i>Coated marble top finishes:</i> Carrara: white-grey (suffix GC) Empire Beige: beige (suffix GB)
C Casters	<i>Granite top finishes:</i> Black Andes: black (suffix GA)
111 Jet Black laminate	<i>Low Tables:</i> D’Urso tables are available in two heights: standard and low. For low tables, add an L after the parent pattern number. Example: 6348L for low height option.
C Polished Chrome	<i>Maintenance:</i> See pages 28-29.
	<i>Note:</i> D’urso Tables with Laminate, Veneer or Granite tops and PVC edge are Greenguard certified.
	Weight information above is based on work height tables. For weight information on low height tables, please contact your KnollStudio representative.
	<i>Leg finishes:</i>  Jet Black (suffix 111) Medium Metallic Grey (suffix 612) Polished Chrome (suffix C) Red (suffix RD)
	<i>Glides/ casters:</i> Casters (suffix C)  Glides, standard option (suffix GL) Locking casters (suffix CX)
	<i>KnollStudio 20-Day Program:</i> The D’Urso 6348 Work Table is available on the KnollStudio 20-Day program with black legs and glides. All laminates in stock can be specified for top finishes. For specific information, consult pages 30-33.



- Specify:*
1. Pattern number
 2. Specify L for low height tables
 3. Glides/casters selection
 4. Top finish selection
 5. Leg finish selection

Figured Techgrain top finishes:
American Cherry (suffix P)
Cherry (suffix R)
Maple (suffix M)
Medium Red Mahogany (suffix C)

Natural veneer top finishes:
American Cherry (suffix X)
Maple (suffix K)

Natural marble top finishes:
Carrara: white-grey (suffix NGC)

pattern no.	upcharge	base painted	base chrome
6348-(-)(-)(-) 		\$2,765.	\$3,230.
6348-(-)(-)(-)		3,975.	4,438.
6348-(-)(-)(-)		4,660.	5,122.
6348-(-)(NGC)-(-)		6,489.	6,953.
6348-(-)(GC, GB)-(-)		7,531.	7,994.
6354-(-)(-)(-)		2,870.	3,333.
6354-(-)(-)(-)		4,081.	4,546.
6354-(-)(-)(-)		4,818.	5,283.
6354-(-)(NGC)-(-)		7,615.	8,077.
6354-(-)(GC, GB)-(-)		8,928.	9,391.
6354-(-)GA-(-)		10,219.	10,680.
6360-(-)(-)(-)		3,127.	3,589.
6360-(-)(-)(-)		4,608.	5,070.
6360-(-)(-)(-)		5,562.	6,025.
6360-(-)(NGC)-(-)		8,812.	9,276.
6360-(-)(GC, GB)-(-)		10,422.	10,885.
6360-(-)GA-(-)		11,487.	11,951.
GL	n/c		
C	668.		
CX	761.		

Construction
<i>Top:</i> Laminate, Techgrain® and veneer or stone surface. Laminate, Techgrain® and veneer tops are 3-ply construction with medium density fiberboard core and plastic laminate backer (laminate tops) or paper backer (wood veneer tops). Laminate, Techgrain® and veneer tops have a black vinyl bullnose edge. Wood tops are longitudinal veneered. 3/4" thick stone tops have an integral, hand-crafted bullnose edge.
<i>Edge detail:</i> Laminate/Techgrain/wood tops:  Stone tops: 
<i>Glides:</i> Black nylon. <i>Casters:</i> 3" single, black hard-rubber wheel. Polished chrome wheel housings with black or medium metallic grey legs. Black housings with polished chrome and red leg. Locking caster housings always polished chrome. Tables with casters are at the same height as tables with glides.
<i>Base:</i> Racetrack-shaped steel legs with painted or polished chrome finish.
Wood tables with casters are weighted with steel plates to ensure stability. Plates are painted and secured under table top. Please note: Casters cannot be retrofitted to tables with glides.



Joseph Paul D’Urso

Round Work and Low Tables







Designer(s):
Joseph Paul D’Urso, 1980

Award(s):
Design Center Stuttgart Award, W. Germany, 1983; Federal Award for Industrial Design, W. Germany, 1983



description	width		h, work tables	h, low tables	weight	top
	between legs	w				
6242 Round table, small 	20 7/8"	42"	27 1/2"	15 1/4"	110 lbs.	laminata
	20 7/8"	42"	27 1/2"	15 1/4"	109 lbs.	figured techgrain®
	20 7/8"	42"	27 1/2"	15 1/4"	109 lbs.	natural veneer
	20 7/8"	42"	27 1/2"	15 1/4"	132 lbs.	natural marble
	20 7/8"	42"	27 1/2"	15 1/4"	132 lbs.	coated marble
6248 Round table, medium 	22 1/2"	48"	27 1/2"	15 1/4"	120 lbs.	laminata
	22 1/2"	48"	27 1/2"	15 1/4"	118 lbs.	figured techgrain®
	22 1/2"	48"	27 1/2"	15 1/4"	118 lbs.	natural veneer
	22 1/2"	48"	27 1/2"	15 1/4"	162 lbs.	natural marble
	22 1/2"	48"	27 1/2"	15 1/4"	162 lbs.	coated marble
6254 Round table, medium 	25 1/8"	54"	27 1/2"	15 1/4"	156 lbs.	laminata
	25 1/8"	54"	27 1/2"	15 1/4"	153 lbs.	figured techgrain®
	25 1/8"	54"	27 1/2"	15 1/4"	153 lbs.	natural veneer
	25 1/8"	54"	27 1/2"	15 1/4"	197 lbs.	natural marble
	25 1/8"	54"	27 1/2"	15 1/4"	197 lbs.	coated marble
	25 1/8"	54"	27 1/2"	15 1/4"	229 lbs.	granite
C Casters						
GL Glides						
CX Locking casters						

pattern no.	upcharge	base painted	base chrome
6242-(-)(-)(-) 		\$2,616.	\$3,076.
6242-(-)(-)(-)		3,867.	4,327.
6242-(-)(-)(-)		4,554.	5,014.
6242-(-)(NGC)-(-)		4,723.	5,184.
6242-(-)(GC, GB)-(-)		5,352.	5,813.
6248-(-)(-)(-)		2,765.	3,230.
6248-(-)(-)(-)		3,975.	4,438.
6248-(-)(-)(-)		4,660.	5,122.
6248-(-)(NGC)-(-)		5,562.	6,023.
6248-(-)(GC, GB)-(-)		6,385.	6,845.
6254-(-)(-)(-)		2,870.	3,333.
6254-(-)(-)(-)		4,081.	4,546.
6254-(-)(-)(-)		4,818.	5,283.
6254-(-)(NGC)-(-)		6,519.	6,982.
6254-(-)(GC, GB)-(-)		7,560.	8,022.
6254-(-)(GA)-(-)		10,440.	10,902.
C	668.		
GL	n/c		
CX	761.		

Order Code	Ordering Information		
<i>Example:</i> 6248-C-NGC-C	<i>Laminate top finishes:</i>	<i>Natural veneer top finishes:</i>	<i>Granite top finishes</i>
6248 48" diameter round table	 Bright White (suffix 118)	American Cherry (suffix X)	Black Andes: black (suffix GA)
C Casters	 Fog (suffix 123)	Maple (suffix K)	
NGC Carrara Marble	 Jet Black (suffix 111)	<i>Natural marble top finishes:</i>	<i>Leg finishes:</i>
C Polished Chrome	 Light Grey (suffix L)	Carrara: white-grey (suffix NGC)	 Jet Black (suffix 111)
	 Pumice (suffix 119)		Medium Metallic Grey (suffix 612)
			Polished Chrome (suffix C)
			Red (suffix RD)
	<i>Figured Techgrain top finishes:</i>	<i>Coated marble top finishes:</i>	<i>Glides/casters:</i>
	American Cherry (suffix P)	Carrara: white-grey (suffix GC)	Casters (suffix C)
	Cherry (suffix R)	Empire Beige: beige (suffix GB)	 Glides, standard option (suffix GL)
	Maple (suffix M)		Locking casters (suffix CX)
	Medium Red Mahogany (suffix C)		
<i>Specify:</i>			<i>Low Tables:</i>
1. Pattern number			D’Urso tables are available in two heights: standard and low. For low tables, add an L after the parent pattern number. Example: 6348L for low height option.
2. Specify L for low height tables			
3. Glides/casters selection			
4. Top finish selection			
5. Leg finish selection			

Construction

 *KnollStudio 20-Day Program:*
The 6242 D’Urso Work Table with black legs and glides is available on the KnollStudio 20-Day program. All laminates in stock can be specified for the top finish. For specific information, consult pages 30-33.

Maintenance:
See pages 28-29.

Note:
The D’Urso Tables with Laminate, Veneer or Granite tops and PVC edge are Greenguard certified.

Weight information above is based on work height tables. For weight information on low height tables, please contact your KnollStudio representative.

Top:
Laminate, Techgrain® and veneer or stone surface. Laminate, Techgrain® and veneer tops are 3-ply construction with medium density fiberboard core and plastic laminate backer (laminata tops) or paper backer (wood veneer tops). Laminate, Techgrain® and veneer tops have a black vinyl bullnose edge. 3/4" thick stone tops have an integral, hand-crafted bullnose edge.

Edge detail:
Laminate/Techgrain/wood tops

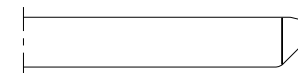

Stone tops:

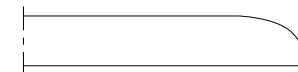

Base:
Racetrack-shaped steel legs with painted or polished chrome finish.

Glides:
Black nylon.



Casters:
3" single, black hard-rubber wheel. Polished chrome wheel housings with black or medium metallic grey legs. Black housings with polished chrome and red leg. Locking caster housings always polished chrome.

Wood tables with casters are weighted with steel plates to ensure stability. Plates are painted and secured under table top.





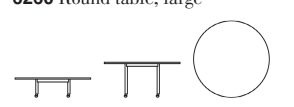
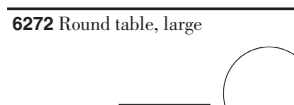

Please note: Casters cannot be retrofitted to tables with glides.

Joseph Paul D’Urso

Round Work and Low Tables

	description	width		h, work tables	h, low tables	weight	top
		between legs	w				
<i>Designer(s):</i> Joseph Paul D’Urso, 1980	6260 Round table, large 	25 1/8"	60"	27 1/2"	15 1/4"	164 lbs.	figured techgrain®
		25 1/8"	60"	27 1/2"	15 1/4"	164 lbs.	natural veneer
		25 1/8"	60"	27 1/2"	15 1/4"	167 lbs.	laminated
		25 1/8"	60"	27 1/2"	15 1/4"	235 lbs.	coated marble
		25 1/8"	60"	27 1/2"	15 1/4"	235 lbs.	natural marble
		25 1/8"	60"	27 1/2"	15 1/4"	274 lbs.	granite
<i>Award(s):</i> Design Center Stuttgart Award, W. Germany, 1983; Federal Award for Industrial Design, W. Germany, 1983	6272 Round table, large 	31"	72"	27 1/2"	15 1/4"	255 lbs.	Natural veneer
	C Casters						
	GL Glides						
	CX Locking casters						

pattern no.	upcharge	base, painted	base, chrome
6260-()-()-()		\$4,608.	\$5,070.
6260-()-()-()		5,562.	6,025.
6260-()-()-()		3,127.	3,589.
6260-()-(GC, GB)-()		8,698.	9,161.
6260-()-(NGC)-()		7,433.	7,896.
6260-()-GA-()		11,435.	11,899.
6272-()-()-()		6,619.	7,149.
C	668.		
GL	n/c		
CX	761.		

Order Code	Order Information
<i>Example:</i> 6248-C-NGC-C	
6248 48" diameter round table	<i>Laminate top finishes:</i>  Bright White (suffix 118)  Fog (suffix 123)  Jet Black (suffix 111)  Light Grey (suffix L)  Pumice (suffix 119)
C Casters	<i>Natural veneer top finishes:</i> American Cherry (suffix X) Maple (suffix K)
NGC Carrara Marble	<i>Natural marble top finishes:</i> Carrara: white-grey (suffix NGC)
C Polished Chrome	<i>Coated marble top finishes:</i> Carrara: white-grey (suffix GC) Empire Beige: beige (suffix GB)
	<i>Figured Techgrain top finishes:</i> American Cherry (suffix P) Cherry (suffix R) Maple (suffix M) Medium Red Mahogany (suffix C)
<i>Specify:</i>	<i>Granite top finishes:</i> Black Andes: black (suffix GA)
1. Pattern number	<i>Leg finishes:</i>  Jet Black (suffix 111) Medium Metallic Grey (suffix 612) Polished Chrome (suffix C) Red (suffix RD)
2. Specify L for low height tables	<i>Glides/casters:</i> Casters (suffix C)  Glides, standard option (suffix GL) Locking casters (suffix CX)
3. Glides/casters selection	<i>Low Tables:</i> D’Urso tables are available in two heights: standard and low. For low tables, add an L after the parent pattern number. Example: 6348L for low height option.
4. Top finish selection	
5. Leg finish selection	

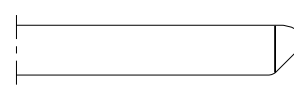
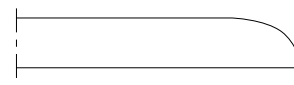
Construction
<p> <i>KnollStudio 20-Day Program:</i> The 6242 D’Urso Work Table with black legs and glides is available on the KnollStudio 20-Day program. All laminates in stock can be specified for the top finish. For specific information, consult pages 30-33.</p> <p><i>Maintenance:</i> See pages 28-29.</p> <p><i>Note:</i> The D’Urso Tables with Laminate, Veneer or Granite tops and PVC edge are Greenguard certified.</p> <p>Weight information above is based on work height tables. For weight information on low height tables, please contact your KnollStudio representative.</p>
<p><i>Top:</i> Laminate, Techgrain® and veneer or stone surface. Laminate, Techgrain® and veneer tops are 3-ply construction with medium density fiberboard core and plastic laminate backer (laminate tops) or paper backer (wood veneer tops). Laminate, Techgrain® and veneer tops have a black vinyl bullnose edge. 3/4" thick stone tops have an integral, hand-crafted bullnose edge.</p> <p><i>Edge detail:</i> Laminate/Techgrain/wood tops</p>  <p>Stone tops:</p> 
<p><i>Base:</i> Racetrack-shaped steel legs with painted or polished chrome finish.</p> <p><i>Glides:</i> Black nylon.</p> <p><i>Casters:</i> 3" single, black hard-rubber wheel. Polished chrome wheel housings with black or medium metallic grey legs. Black housings with polished chrome and red leg. Locking caster housings always polished chrome.</p> <p>Wood tables with casters are weighted with steel plates to ensure stability. Plates are painted and secured under table top.</p> <p>Please note: Casters cannot be retrofitted to tables with glides.</p>

Joseph Paul D'Urso

Racetrack Work Tables

Designer(s):
Joseph Paul D'Urso, 1980

Award(s):
Design Center Stuttgart Award, W. Germany, 1983; Federal Award for Industrial Design, W. Germany, 1983

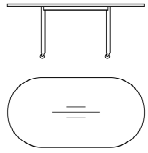

description	w between legs		d between legs		h	weight	top
	w	d	w	d			
6472 Racetrack table, small 	32 3/4"	20 3/8"	72"	36"	27 1/2"	144 lbs.	laminata
	32 3/4"	20 3/8"	72"	36"	27 1/2"	141 lbs.	figured techgrain®
	32 3/4"	20 3/8"	72"	36"	27 1/2"	141 lbs.	natural veneer
	32 3/4"	20 3/8"	72"	36"	27 1/2"	200 lbs.	natural marble
	32 3/4"	20 3/8"	72"	36"	27 1/2"	200 lbs.	coated marble
	32 3/4"	20 3/8"	72"	36"	27 1/2"	232 lbs.	granite

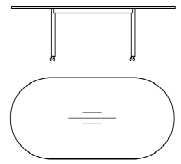
6484 Racetrack table, medium 	38 3/4"	20 3/8"	84"	42"	27 1/2"	162 lbs.	laminata
	38 3/4"	20 3/8"	84"	42"	27 1/2"	159 lbs.	figured techgrain®
	38 3/4"	20 3/8"	84"	42"	27 1/2"	159 lbs.	natural veneer
	38 3/4"	20 3/8"	84"	42"	27 1/2"	294 lbs.	natural marble
	38 3/4"	20 3/8"	84"	42"	27 1/2"	294 lbs.	coated marble
	38 3/4"	20 3/8"	84"	42"	27 1/2"	338 lbs.	granite

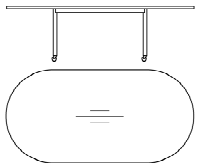
6496 Racetrack table, large 	44 3/4"	22 1/2"	96"	48"	27 1/2"	177 lbs.	laminata
	44 3/4"	22 1/2"	96"	48"	27 1/2"	173 lbs.	figured techgrain®
	44 3/4"	22 1/2"	96"	48"	27 1/2"	173 lbs.	natural veneer
	44 3/4"	22 1/2"	96"	48"	27 1/2"	377 lbs.	natural marble
	44 3/4"	22 1/2"	96"	48"	27 1/2"	377 lbs.	coated marble
	44 3/4"	22 1/2"	96"	48"	27 1/2"	434 lbs.	granite

GL Glides

C Casters

CX Locking casters

Order Code





Example:	6472-GL-GA-C
6472	72" x 36" racetrack table
GL	Glides
GA	Granite
C	Polished Chrome

Specify:

1. Pattern number
2. Specify L for low height tables
3. Glides/casters selection
4. Top finish selection
5. Leg finish selection

Ordering Information

Laminata top finishes:

-  Bright White (suffix 118)
-  Fog (suffix 128)
-  Jet Black (suffix 111)
-  Light Grey (suffix L)
-  Pumice (suffix 119)

Figured Techgrain top finishes:

- American Cherry (suffix P)
- Cherry (suffix R)
- Maple (suffix M)
- Medium Red Mahogany (suffix C)

Natural veneer top finishes:

- American Cherry (suffix X)
- Maple (suffix K)

Natural marble top finishes:

- Carrara: white-grey (suffix NGC)

Coated marble top finishes:

- Carrara: white-grey (suffix GC)
- Empire Beige: beige (suffix GB)

Granite top finish:

- Black Andes: black (suffix GA)

Leg finishes:

-  Jet Black (suffix 111)
- Medium Metallic Grey (suffix 612)
- Polished Chrome (suffix C)
- Red (suffix RD)

Glides/casters:

- Casters (suffix C)
-  Glides, standard option (suffix GL)
- Locking casters (suffix CX)

Casters not available on stone racetrack tables.

 **KnollStudio 20-Day Program:**

The 6472 D'Urso Table with black legs and glides is available on the KnollStudio 20-Day program. All laminates in stock can be specified for top finish. For specific information, consult pages 30-33.

pattern no.	upcharge	base painted	base chrome
6472-()-()-() 		\$3,536.	\$3,999.
6472-()-()-()		4,961.	5,420.
6472-()-()-()		5,684.	6,144.
6472-()-(NGC)-()		7,086.	7,545.
6472-()-(GC, GB)-()		8,246.	8,709.
6472-()-(GA)-()		11,485.	11,945.

6484-()-()-()		3,794.	4,256.
6484-()-()-()		5,259.	5,722.
6484-()-()-()		6,350.	6,812.
6484-()-(NGC)-()		9,546.	10,008.
6484-()-(GC, GB)-()		11,093.	11,555.
6484-()-(GA)-()		13,271.	13,734.

6496-()-()-()		3,898.	4,357.
6496-()-()-()		5,562.	6,023.
6496-()-()-()		6,952.	7,414.
6496-()-(NGC)-()		11,974.	12,433.
6496-()-(GC, GB)-()		14,071.	14,531.
6496-()-(GA)-()		15,957.	16,417.

GL

n/c

C

668.

CX

761.

Construction

Maintenance:

See pages 28-29.

Note:

The D'Urso Tables with Laminata, Veneer or Granite tops and PVC edge are Greenguard certified.

Weight information above is based on work height tables. For weight information on low height tables, please contact your KnollStudio representative.

Top:

Laminata, Techgrain® and veneer or stone surface. Laminata, Techgrain® and veneer tops are 3-ply construction with medium density fiberboard core and plastic laminata backer (laminata tops) or paper backer (wood veneer tops). Laminata, Techgrain® and veneer tops have a black vinyl bullnose edge. Wood tops are longitudinal veneered. 3/4" thick stone tops have an integral, hand-crafted bullnose edge.

Edge detail:

Laminata/Techgrain/wood tops:

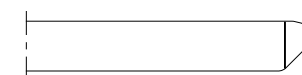

Stone tops:



Base:

Racetrack-shaped steel legs with painted or polished chrome finish.

Glides:

Black nylon.

Casters:

3" single, black hard-rubber wheel. Polished chrome wheel housings with black or medium metallic grey legs. Black housings with polished chrome and red leg. Locking caster housings always polished chrome. Not available on stone racetrack tables.

Wood tables with casters are weighted with steel plates to ensure stability. Plates are painted and secured under table top.

Please note: Casters cannot be retrofitted to tables with glides.

Frank Gehry Face Off Cafe Table

Designer(s):
Frank Gehry, 1990

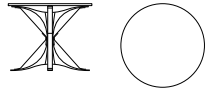
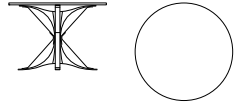

description	w	d	h	weight	top	base
95T-36 Face Off 36" café table 	36"		28 3/4"	10 lbs.	glass	clear maple
	36"		28 3/4"	10 lbs.	white laminate	clear maple
95T-40 Face Off 40" café table 	40"		28 3/4"	10 lbs.	glass	clear maple
	40"		28 3/4"	10 lbs.	white laminate	clear maple

pattern no.	
95T-36-G2-GC	\$4,788.
95T-36-W-GC	5,676.
95T-40-G2-GC	5,762.
95T-40-W-GC	6,645.

Order Code

Example:	95T-36-G2-GC
95T-36	36" Face Off table
G2	Clear Glass
GC	Clear Maple

Note:
The Gehry tables are part of a collection. Please refer to Gehry side chairs and lounge seating starting on page 126.

Specify:

1. Pattern number
2. Top finish selection

Ordering Information

Glass top finish:
Clear Glass (suffix G2)

Laminate top finish :
White (suffix W)

Maple Base finish:
Clear (suffix GC)

Shipping note:
Tops ship separately.

Signature:
The underside of each piece in the Gehry Collection is embossed with Frank Gehry's signature and the Knoll logo.

Maintenance:
See pages 28-29.

Construction

Face Off Cafe Table tops:
1/2" thick tempered clear glass with polished edge; 3/8" thick textured laminate top with clear solid edgeband. Four bolts attach table top to base.

Face Off Cafe Table base:
Constructed of hard white maple veneers in 2" wide, 1/8" thick strips. Laminated to 7-ply thickness with high-bonding urea glue. All wood grains run in the same direction for resilience. State-of-the-art thermoset assembly glue provides structural rigidity without the need for metal connectors. Solid maple center column prevents cracking. Arched base design allows ample leg room.

Glides:
Clear plastic with a matte frost finish.

Alexander Girard
Coffee Table

	description	w	d	h	weight
<i>Designer(s):</i> Alexander Girard, 1948 	108 Coffee Table	59"	26"	16"	23 lbs.
		59"	26"	16"	23 lbs.

pattern no.	
108-(LWA, D, V319)-111	\$1,608.
108-KC-111	2,056.

Order Code	Ordering Information	Construction
<i>Example:</i> 108-LWA-111	<i>Top Finishes:</i>	<i>Top:</i>
108 Coffee Table	Ebonized Walnut (suffix D)	Top is 3/4" baltic birch core with either
LWA Light Walnut	Light Walnut (suffix LWA)	plain slice bookmatch maple, cherry or
111 Jet Black	Maple (suffix K)	ebonized veneer. Top has a 45° beveled
	Medium Cherry (suffix V319)	edge.
<i>Specify:</i>	<i>Leg Finish:</i>	<i>Legs:</i>
1. Pattern number	Jet Black (suffix 111)	Cold-roll steel tubes with metal
2. Top finish delection		weldment in black powder coat.
3. Leg finish selection		

Florence Knoll

Oval Table Desks

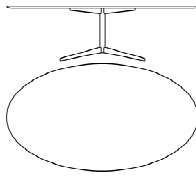
	description	w	d	h	weight	top		
<p><i>Designer(s):</i> Florence Knoll, 1961</p> <p><i>Award(s):</i> Design Center Stuttgart Award, 1969-70</p> 	2480D Oval table desk	78"	47 3/4"	27 1/2"	313 lbs.	natural marble		
		78"	47 3/4"	28"	185 lbs.	white laminate		
		78"	47 3/4"	27 1/2"	313 lbs.	coated marble		
		78"	47 3/4"	28"	174 lbs.	natural oak		
		78"	47 3/4"	27 1/2"	313 lbs.	coated marble		
		78"	47 3/4"	28"	174 lbs.	mahogany		
		78"	47 3/4"	28"	174 lbs.	ebonized oak		
		78"	47 3/4"	27 1/2"	313 lbs.	coated marble		
		78"	47 3/4"	27 1/2"	313 lbs.	coated marble		
		78"	47 3/4"	28"	174 lbs.	pearwood		
		78"	47 3/4"	27 1/2"	313 lbs.	coated marble		
		78"	47 3/4"	27 1/2"	313 lbs.	coated marble		
			2481D Oval table desk	96"	54"	27 1/2"	402 lbs.	natural marble
				96"	54"	27 1/2"	402 lbs.	coated marble
				96"	54"	28"	223 lbs.	white laminate
96"	54"			27 1/2"	402 lbs.	coated marble		
96"	54"			28"	207 lbs.	natural oak		
96"	54"			28"	207 lbs.	mahogany		
96"	54"			28"	207 lbs.	ebonized oak		
96"	54"			27 1/2"	402 lbs.	coated marble		
96"	54"			28"	207 lbs.	pearwood		
96"	54"			27 1/2"	402 lbs.	coated marble		
96"	54"			27 1/2"	402 lbs.	coated marble		
96"	54"			27 1/2"	402 lbs.	coated marble		

pattern no.	polished chrome base (C)	satin chrome base (CO)
2480D-()-(NGC)	\$9,734.	\$10,161.
2480D-()-F2	9,938.	10,369.
2480D-()-(MG, MGS)	10,490.	10,904.
2480D-()-O	11,026.	11,454.
2480D-()-(GC, GCS, GB, GBS)	11,176.	11,605.
2480D-()-(M7, M9)	11,518.	11,942.
2480D-()-E	12,001.	12,429.
2480D-()-(MN, MNS, MA, MAS, GG, GGS)	12,942.	13,367.
2480-()-(ME, MES)	13,056.	13,470.
2480D-()-P	13,205.	13,633.
2480D-()-(MC, MCS)	13,718.	14,146.
2480D-()-(MV, MVS)	16,833.	17,259.
2481D-()-(NGC)	11,797.	12,221.
2481D-()-(MG, MGS)	13,342.	13,754.
2481D-()-F2	13,718.	14,144.
2481D-()-(GC, GCS, GB, GBS)	13,805.	14,232.
2481D-()-O	15,030.	15,454.
2481D-()-(M7, M9)	15,516.	15,939.
2481D-()-E	16,004.	16,430.
2481D-()-(ME, MES)	17,261.	17,673.
2481D-()-P	17,608.	18,032.
2481D-()-(MN, MNS, MA, MAS, GG, GGS)	17,825.	18,251.
2481D-()-(MC, MCS)	18,895.	19,318.
2481D-()-(MV, MVS)	23,113.	23,539.

Order Code



<i>Example:</i>	2510T-C-G2
2510T	Florence Knoll square coffee table
C	Polished Chrome
G2	Clear glass



Note:
Florence Knoll coffee tables are part of a collection. Please refer to Florence Knoll lounge seating on page 134 and desks and credenzas beginning on page 310.





Specify:

1. Pattern number
2. Base finish option
3. Top selection

Ordering Information

Base finishes:
 Polished Chrome (suffix C)
 Satin Chrome (suffix CO)

Glass top finishes:
 Black Glass (suffix C1)
 Clear Glass (suffix G2)
 White Glass (suffix C2)

Veneer finishes:
 Ebonized Walnut (suffix D)
 Light Oak (suffix LO)
 Light Walnut (suffix LWA)
 Reff Dark Cherry (suffix V314)

Pearwood finish:
 Pearwood (suffix P)

Polished Coated marble top finishes:
 Arabescato: white-grey (suffix MA)
 Calacatta: white-grey/beige (suffix MC)
 Carrara: white-grey (suffix GC)
 Empire Beige: beige (suffix GB)
 Espresso: dark brown (suffix ME)
 Grey Marble: light grey (suffix GG)
 Grigio Marquina: warm grey (suffix MG)
 Nero Marquina: black (suffix MN)
 Verdi Alpi: green (suffix MV)

Satin Coated marble top finishes:
 Arabescato: white-grey (suffix MAS)
 Calacatta: white-grey/beige (suffix MCS)
 Carrara: white-grey (suffix GCS)
 Empire Beige: beige (suffix GBS)
 Espresso: dark brown (suffix MES)
 Grey Marble: light grey (suffix GGS)
 Grigio Marquina: warm grey (suffix MGS)
 Nero Marquina: black (suffix MNS)
 Verde Alpi: green (suffix MVS)

Natural marble top finishes:
 Calacatta: white-grey/beige (suffix NC)
 Carrara: white-grey (suffix NGC)

Granite top finish:
 Black Andes: black (suffix GA)

 **KnollStudio 20-Day Program:**
 The Florence Knoll 2510T and 2511T tables in polished chrome finish and clear glass top are available on the KnollStudio 20-Day program. For specific information, consult pages 30-33.

Note:
 Wood finishes on Florence Knoll low tables differ from those on the table desk and credenzas.

Base:
 Polished chrome-plated or satin chrome-plated steel.

Maintenance:
 See pages 28-29.

Note:
 KnollStudio logo and signature of Florence Knoll are stamped into the base.

The Florence Knoll Coffee and End Tables in all finishes are Greenguard certified.

Construction

Top:
 5/8" thick polished plate glass or coated marble with transparent polyester to help eliminate use-associated stains. 3/4" thick natural marble and granite top with protective sealer.

Note:
 Marbles with a coating will yellow over time.

Wood Top:
 Tops are constructed of veneered medium density fiberboard with a cathedral grain pattern in various toned or stained finishes for light oak, light walnut, reff dark cherry and pearwood. Ebonized walnut features a black stain on walnut substrate. Tops are 3/4" thick. Base and Top ship separately. Top is attached to base with wood screws that are enclosed in hardware packet.

Florence Knoll Round Table Desk

	description	w	d	h	weight	top
<p><i>Designer(s):</i> Florence Knoll, 1961</p> <p><i>Award(s):</i> Design Center Stuttgart Award, 1969-70</p> 	2482T Round table desk	54"		28"	142 lbs.	white laminate
		54"		27 1/2"	241 lbs.	natural marble
	54"		27 1/2"	241 lbs.	241 lbs.	coated marble
	54"		27 1/2"	241 lbs.	241 lbs.	coated marble
	54"		27 1/2"	241 lbs.	241 lbs.	coated marble
	54"		28"	134 lbs.	134 lbs.	natural oak
	54"		28"	134 lbs.	134 lbs.	mahogany
	54"		28"	134 lbs.	134 lbs.	ebonized oak
	54"		27 1/2"	241 lbs.	241 lbs.	coated marble
	54"		28"	134 lbs.	134 lbs.	pearwood
	54"		27 1/2"	241 lbs.	241 lbs.	coated marble
	54"		27 1/2"	241 lbs.	241 lbs.	coated marble

pattern no.	polished chrome base (C)	satin chrome base (CO)
2482T-()-F2	\$7,920.	\$8,409.
2482T-()-(NGC)	8,626.	9,112.
2482T-()-(MG, MGS)	9,075.	9,547.
2482T-()-(GC, GCS, GB, GBS)	9,656.	10,143.
2482-()-(ME, MES)	10,604.	11,076.
2482T-()-O	10,822.	11,311.
2482T-()-(M7, M9)	11,283.	11,771.
2482T-()-E	11,746.	12,236.
2482T-()-(MN, MNS, MA, MAS, GG, GGS)	12,863.	13,350.
2482T-()-P	12,921.	13,411.
2482T-()-(MC, MCS)	13,506.	13,993.
2482T-()-(MV, MVS)	16,743.	17,230.

Order Code	Ordering Information
<i>Example:</i> 2480T-C-NGC	
2480T	Florence Knoll Oval Table Desk
C	Polished Chrome
NGC	Carrara Marble
<i>Note:</i> Florence Knoll table desks are part of a collection. Please refer to Florence Knoll lounge seating on page 134 and credenzas, conference and low tables on the following pages.	
<i>Specify:</i> 1. Pattern number 2. Base finish option 3. Top finish selection	
	<p><i>Base finishes:</i> Polished Chrome (suffix C) Satin Chrome (suffix CO)</p> <p><i>Laminate top finish:</i> White Laminate (suffix F2)</p> <p><i>Veneer top finishes:</i> Ebonized Oak (suffix E) Natural Oak (suffix O) Medium Brown Mahogany (suffix M7) Medium Red Mahogany (suffix M9) Pearwood (suffix P)</p> <p><i>Polished Coated marble top finishes:</i> Arabescato: white-grey (suffix MA) Calacatta: white-grey/beige (suffix MC) Carrara: white-grey (suffix GC) Empire Beige: beige (suffix GB) Espresso: dark brown (suffix ME) Grey Marble: light grey (suffix GG) Grigio Marquina: warm grey (suffix MG) Nero Marquina: black (suffix MN) Verde Alpi: green (suffix MV)</p> <p><i>Satin Coated marble top finishes:</i> Arabescato: white-grey (suffix MAS) Calacatta: white-grey/beige (suffix MCS) Carrara: white-grey (suffix GCS) Empire Beige: beige (suffix GBS) Espresso: dark brown (suffix MES) Grey Marble: light grey (suffix GGS) Grigio Marquina: warm grey (suffix MGS) Nero Marquina: black (suffix MNS) Verde Alpi: green (suffix MVS)</p> <p><i>Natural marble top finishes:</i> Carrara: white-grey (suffix NGC)</p> <p><i>Maintenance:</i> See pages 28-29.</p> <p><i>Note:</i> The KnollStudio logo and signature of Florence Knoll are stamped into the base of the table.</p> <p>The Florence Knoll Oval Table Desk is Greenguard certified.</p>

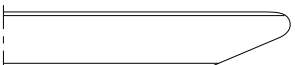
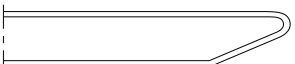
Construction
<p><i>Base:</i> Frame and legs heavy gauge welded steel. Post and four-star legs in polished chrome finish. Optional satin chrome finish.</p> <p><i>Base footprint dimensions:</i> Base dimensions for the 2480D and 2481D are 42 3/8" w x 27 3/8" d. Base dimensions for the 2482T are 28 3/8" w x 28 3/8" d.</p> <p><i>Laminate edge detail:</i> </p> <p><i>Top:</i> Satin finish smooth laminate, wood veneer, or marble with bevel-edge. Laminate tops are 1 1/8" thick and veneer tops are 1 7/16" thick. Marble is 3/4" thick. Marble coated with transparent polyester to help eliminate use-associated stains.</p> <p><i>Note:</i> Marbles with a coating will yellow over time.</p> <p><i>Marble edge detail:</i> </p> <p><i>Glides:</i> Adjustable steel glides with a chrome finish.</p>

Florence Knoll

Dining Tables and Mini Desk

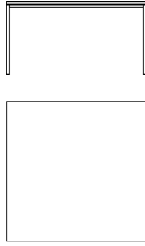
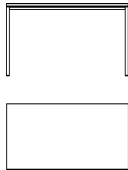
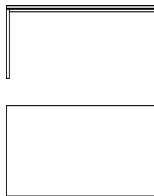
	description	w	d	h	weight	top
Designer(s): Florence Knoll, 1954 Award(s): American Institute of Interior Designers First Award, USA, 1954 	2520T Square Table 	55 1/8"	55 1/8"	28 3/8"	243 lbs.	Coated marble
		55 1/8"	55 1/8"	28 3/8"	243 lbs.	Coated marble
		55 1/8"	55 1/8"	28 3/8"	243 lbs.	Coated marble
		55 1/8"	55 1/8"	28 3/8"	243 lbs.	Coated marble
		55 1/8"	55 1/8"	28 3/8"	243 lbs.	Coated marble
	2521T Mini Desk 	48"	26"	28 3/8"	99 lbs.	Clear glass
		48"	26"	28 3/8"	99 lbs.	Coated marble
		48"	26"	28 3/8"	99 lbs.	Coated marble
		48"	26"	28 3/8"	99 lbs.	Coated marble
		48"	26"	28 3/8"	99 lbs.	Coated marble
	2522T Rectangular Table 	60"	36"	28 3/8"	165 lbs.	Coated marble
		60"	36"	28 3/8"	165 lbs.	Coated marble
		60"	36"	28 3/8"	165 lbs.	Coated marble
		60"	36"	28 3/8"	165 lbs.	Coated marble
		60"	36"	28 3/8"	165 lbs.	Coated marble

pattern no.	polished chrome (suffix C)
2520T-C-(MG, MGS)	\$10,688.
2520T-C-(GC, GCS)	11,473.
2520T-C-(MA, MAS)	12,457.
2520T-C-(MC, MCS)	16,381.
<hr/>	
2521T-C-G2	2,946.
2521T-C-(MG, MGS)	5,673.
2521T-C-(GC, GCS)	5,998.
2521T-C-(MA, MAS)	6,393.
2521T-C-(MC, MCS)	8,013.
<hr/>	
2522T-C-(MG, MGS)	11,109.
2522T-C-(GC, GCS)	11,686.
2522T-C-(MA, MAS)	12,364.
2522T-C-(MC, MCS)	15,136.

Order Code

<i>Example:</i> 2523T-C-MGS	Florence Knoll Rectangular Dining Table
C	Polished Chrome
MGS	Grigio Marquina, Satin

- Specify:*
1. Pattern number
 2. Base finish option
 3. Top finish selection

Ordering Information

Base finishes:
 Polished Chrome (suffix C)

Glass top finishes:
 Clear Glass (suffix G2) *

Polished Coated marble top finishes:
 Arabescato: white-grey (suffix MA)
 Calacatta: white-grey/beige (suffix MC)
 Carrara: white-grey (suffix GC)
 Grigio Marquina: warm grey (suffix MG)

Satin Coated marble top finishes:
 Arabescato: white-grey (suffix MAS)
 Calacatta: white-grey/beige (suffix MCS)
 Carrara: white-grey (suffix GCS)
 Grigio Marquina: warm grey (suffix MGS)

*available on 2521T only

Maintenance:
 See pages 28-29.

Note:
 The KnollStudio logo and signature of Florence Knoll are stamped into the base of the table.

Construction

Top:
 Thick polished plate glass or coated marble with transparent polyester coating in polished or satin finish to help eliminate use-associated stains. Marble tops arrive with a 1/8" thick black high density particle board spacer glued underneath the perimeter and rests on the table frame with double sided adhesive.

Note:
 Marbles with a coating will yellow over time giving the marble a warmer tone.

Base:
 Legs are made of solid steel bars and connected to horizontal steel tube rails using steel connectors.

Substructure:
 Larger tables, 2523T and 2524T, include an added cross bar between the rails and feature a tension rod substructure to help support the weight of the marble top. Four steel rods connected to the top corners of the table base converge into a chrome box attached to the cross bar. This hidden structure prevents any deflection of the marble.

Tension rod substructure for 2523T and 2524T:

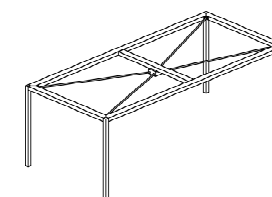

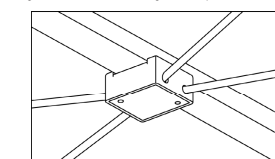

Tension rod and chrome box detail (view from underside of table):

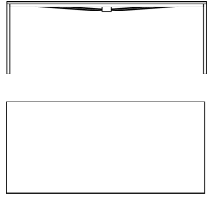

Florence Knoll

Dining Tables and Mini Desk

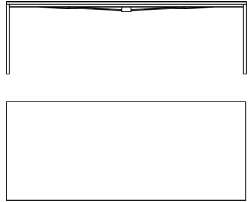
	description	w	d	h	weight	top
Designer(s): Florence Knoll, 1954 Award(s): American Institute of Interior Designers First Award, USA, 1954	2523T Rectangular Table 	78 7/8"	35 1/2"	28 3/8"	221 lbs.	Coated marble
		78 7/8"	35 1/2"	28 3/8"	221 lbs.	Coated marble
		78 7/8"	35 1/2"	28 3/8"	221 lbs.	Coated marble
		78 7/8"	35 1/2"	28 3/8"	221 lbs.	Coated marble
	2524T Rectangular Table 	94 1/2"	39 7/8"	28 3/8"	298 lbs.	Coated marble
		94 1/2"	39 7/8"	28 3/8"	298 lbs.	Coated marble
		94 1/2"	39 7/8"	28 3/8"	298 lbs.	Coated marble
		94 1/2"	39 7/8"	28 3/8"	298 lbs.	Coated marble

pattern no.	polished chrome (suffix C)
2523T-C-(MG, MGS)	\$13,310.
2523T-C-(GC, GCS)	14,034.
2523T-C-(MA, MAS)	14,916.
2523T-C-(MC, MCS)	18,521.
<hr/>	
2524T-C-(MG, MGS)	15,739.
2524T-C-(GC, GCS)	16,709.
2524T-C-(MA, MAS)	17,885.
2524T-C-(MC, MCS)	22,714.

Order Code	Ordering Information	Construction
Example: 2523T-C-MGS 2523T Florence Knoll Rectangular Dining Table C Polished Chrome MGS Grigio Marquina, Satin	Base finishes: Polished Chrome (suffix C) Glass top finishes: Clear Glass (suffix G2) * Polished Coated marble top finishes: Arabescato: white-grey (suffix MA) Calacatta: white-grey/beige (suffix MC) Carrara: white-grey (suffix GC) Grigio Marquina: warm grey (suffix MG) Satin Coated marble top finishes: Arabescato: white-grey (suffix MAS) Calacatta: white-grey/beige (suffix MCS) Carrara: white-grey (suffix GCS) Grigio Marquina: warm grey (suffix MGS) *available on 2521T only	Maintenance: See pages 28-29. Note: The KnollStudio logo and signature of Florence Knoll are stamped into the base of the table. Top: Thick polished plate glass or coated marble with transparent polyester coating in polished or satin finish to help eliminate use-associated stains. Marble tops arrive with a 1/8" thick black high density particle board spacer glued underneath the perimeter and rests on the table frame with double sided adhesive. Note: Marbles with a coating will yellow over time giving the marble a warmer tone. Base: Legs are made of solid steel bars and connected to horizontal steel tube rails using steel connectors.

- Specify:**
1. Pattern number
 2. Base finish option
 3. Top finish selection

Substructure:
 Larger tables, 2523T and 2524T, include an added cross bar between the rails and feature a tension rod substructure to help support the weight of the marble top. Four steel rods connected to the top corners of the table base converge into a chrome box attached to the cross bar. This hidden structure prevents any deflection of the marble.

Tension rod substructure for 2523T and 2524T:

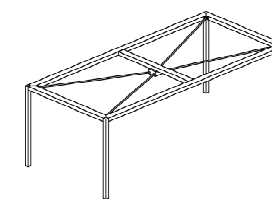

Tension rod and chrome box detail (view from underside of table):

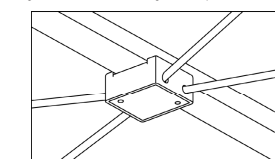

Florence Knoll *Executive Desk*

Designer(s):
Florence Knoll, 1954



description	w	d	h	weight	top
2485D Rectangular desk with two pencil drawers	72"	37 1/4"	29 1/4"	–	Mahogany/Oak/ Walnut
	72"	37 1/4"	29 1/4"	–	Teak
	72"	37 1/4"	29 1/4"	–	Rosewood

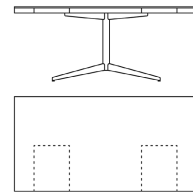

pattern no.	polished chrome base (C)	satin chrome base (CO)
2485D-(C, CO)-()	\$11,392.	\$12,042.
2485D-(C, CO)-(TK)	14,548.	15,199.
2485D-(C, CO)-(RO)	16,412.	17,063.

Order Code

<i>Example:</i> 2485D-C-LWA	
2523T	Florence Knoll rectangular desk
C	Polished Chrome
LWA	Light Walnut

Specify:

1. Pattern number
2. Base finish option
3. Top finish selection

Ordering Information

Base finishes:
Polished Chrome (suffix C)
Satin Chrome (suffix CO)

Veneer top finishes:
Medium Brown Mahogany (suffix M7)
Ebonized Oak (suffix E)
Natural Oak (suffix O)
Light Walnut (suffix LWA)
Rosewood (suffix RO)
Teak (suffix TK)

Maintenance:
See pages 28-29.

Note:
The KnollStudio logo and signature of Florence Knoll are stamped into the base of the table.

Construction

Base:
Frame and legs heavy gauge welded steel. Post and four-star legs in polished chrome finish.

Top:
Top and side are constructed of solid MDF core with veneer faces.

Drawers:
Two pencil drawers are constructed of solid maple lumber. Fronts are solid lumber with veneer face and edge. Pencil tray is solid lumber. Drawers on ball bearing metal slides.

Base footprint dimensions:
Base dimensions for the 2485D is 42 1/8" w x 27 1/8" d.

Glides:
Adjustable steel glides with a chrome finish.





Florence Knoll

Credenzas

Two Position Credenzas

Designer(s):
Florence Knoll, 1961



description	w	d	h	body
2541M Six box drawers (each with one removable partition) 	37 1/2"	18"	25 1/2"	natural oak
	37 1/2"	18"	25 1/2"	mahogany
	37 1/2"	18"	25 1/2"	ebonized oak
	37 1/2"	18"	25 1/2"	pearwood
2542M Four box drawers (each with one removable partition), one full extension file drawer with two metal bars for hanging files 	37 1/2"	18"	25 1/2"	natural oak
	37 1/2"	18"	25 1/2"	mahogany
	37 1/2"	18"	25 1/2"	ebonized oak
	37 1/2"	18"	25 1/2"	pearwood
2545M Two storage cabinets with two adjustable shelves for use in one or both cabinets 	37 1/2"	18"	25 1/2"	white lacquer
	37 1/2"	18"	25 1/2"	natural oak
	37 1/2"	18"	25 1/2"	mahogany
	37 1/2"	18"	25 1/2"	ebonized oak
	37 1/2"	18"	25 1/2"	pearwood
2546M Two box drawers (each with one removable partition), two full extension file drawers with two metal bars for hanging files 	37 1/2"	18"	25 1/2"	natural oak
	37 1/2"	18"	25 1/2"	mahogany
	37 1/2"	18"	25 1/2"	ebonized oak
	37 1/2"	18"	25 1/2"	pearwood

Order Code	Ordering Information
<i>Example:</i> 2545M-C-M9-M9	<i>Specify:</i>
2545M Florence Knoll credenza, two position	1. Pattern number
C Polished Chrome	2. Base finish option
M9 Medium Red Mahogany body	3. Body veneer selection
M9 Medium Red Mahogany top	4. Top marble or wood selection
2545x Optional central locking system	5. Optional central locking system (upcharge \$392)
	<i>Base finishes:</i> Polished Chrome (suffix C) Satin Chrome (suffix CO)
	<i>Body and top veneers/lacquer:</i> Ebonyed Oak (suffix E) Medium Brown Mahogany (suffix M7) Medium Red Mahogany (suffix M9) Natural Oak (suffix O) Pearwood (suffix P) White Lacquer (on 2545M only: suffix 2)
	<i>Polished Coated marble top finishes:</i> Arabescato: white-grey (suffix MA) Calacatta: white-grey/beige (suffix MC) Carrara: white-grey (suffix GC) Empire Beige: beige (suffix GB) Grey Marble: light grey (suffix GG) Nero Marquina: black (suffix MN) Verde Alpi: green (suffix MV)
	<i>Satin Coated marble top finishes:</i> Arabescato: white-grey (suffix MAS) Calacatta: white-grey/beige (suffix MCS) Carrara: white-grey (suffix GCS) Empire Beige: beige (suffix GBS) Grey Marble: light grey (suffix GGS) Nero Marquina: black (suffix MNS) Verde Alpi: green (suffix MVS)
	<i>Central locking:</i> Optional central locking secures drawers and doors instantly with one single key lock located in credenza top (left front side). Add proper lock suffix to item number at an additional cost of \$392. See chart for ordering information.
	Credenza Locking system pattern no.
	2541M 2541X
	2542M 2542X
	2545M 2545X
	2546M 2546X
	<i>Note:</i> KnollStudio logo and Florence Knoll's signature are stamped on each piece.
	For weight information, please contact your KnollStudio representative.
	<i>Maintenance:</i> See pages 28-29.

Florence Knoll credenzas are part of a collection. Please refer to Florence Knoll lounge seating on page 134 and table desks, conference and low tables on beginning on page 310.

pattern no.	wood top/ polished base	(MN, MNS, MA, MAS, MC, MCS MV, MVS, GG, GGS)	(GC, GCS, GB, GBS)	(NGC)	wood top/ satin base	(MN, MNS, MA, MAS, MC, MCS MV, MVS, GG, GGS)	(GC, GCS, GB, GBS)	(NGC)
2541M-()-O-()-()	\$10,798.	\$11,743.	\$11,743.	\$11,495.	\$10,954.	\$11,899.	\$11,899.	\$11,650.
2541M-()-(M7, M9)-()-()	11,455.	12,429.	12,429.	12,168.	11,608.	12,583.	12,583.	12,322.
2541M-()-E-()-()	12,153.	12,978.	12,978.	12,711.	12,309.	13,133.	13,133.	12,864.
2541M-()-P-()-()	14,276.	14,276.	14,276.	14,003.	14,429.	14,430.	14,430.	14,156.
2542M-()-O-()-()	10,419.	11,332.	11,332.	11,081.	10,570.	11,485.	11,485.	11,234.
2542M-()-(M7, M9)-()-()	10,920.	11,879.	11,879.	11,617.	11,072.	12,030.	12,030.	11,770.
2542M-()-E-()-()	11,494.	12,429.	12,429.	12,161.	11,645.	12,580.	12,580.	12,312.
2542M-()-P-()-()	13,672.	13,672.	13,672.	13,407.	13,823.	13,824.	13,824.	13,558.
2545M-()-2-()-()	n/a	9,283.	9,283.	8,969.	n/a	9,438.	9,438.	9,124.
2545M-()-O-()-()	6,849.	7,642.	7,642.	7,429.	7,003.	7,796.	7,796.	7,584.
2545M-()-(M7, M9)-()-()	7,357.	8,193.	8,193.	7,967.	7,512.	8,349.	8,349.	8,121.
2545M-()-E-()-()	7,902.	8,737.	8,737.	8,499.	8,058.	8,891.	8,891.	8,652.
2545M-()-P-()-()	9,610.	9,610.	9,610.	9,392.	9,762.	9,762.	9,762.	9,547.
2546M-()-O-()-()	10,226.	11,129.	11,129.	10,871.	10,378.	11,379.	11,379.	11,122.
2546M-()-(M7, M9)-()-()	10,662.	11,607.	11,607.	11,339.	10,812.	11,858.	11,858.	11,592.
2546M-()-E-()-()	11,168.	12,153.	12,153.	11,881.	11,318.	12,406.	12,406.	12,133.
2546M-()-P-()-()	13,373.	13,373.	13,373.	13,103.	13,523.	13,624.	13,624.	13,356.

Construction
<i>Base:</i> Welded square steel tube in polished chrome finish. Optional satin chrome finish. Adjustable glides.
<i>Body:</i> Wood veneer sides and matching back panel in oak, pearwood, or mahogany. Oak, mahogany and pearwood finished with transparent polyurethane coat. Only 2545M storage cabinet available in white lacquer.
<i>Top :</i> 3/4" thick marble coated with transparent polyester to help eliminate use-associated stains. Squared edge detail. 3/4" wood top matching body available. Wood tops finished with transparent polyurethane coat.
<i>Front:</i> Drawer and door fronts in same wood veneers or lacquer finish as body. All have polished aluminum pulls, top flush mounted storage doors with magnetic closures. Location A storage hinges open from left. Location B storage hinges open from right. Other hinging available as special. Pull out drawers with smooth-glide extension slides. Drawer and storage have matching veneer inside.
<i>Note:</i> Marbles with a coating will yellow over time.

Florence Knoll

Credenzas

Four Position Credenzas

Designer(s):
Florence Knoll, 1961



description	w	d	h	body
2543M Eight box drawers (each with one removable partition), two full-extension file drawers with two metal bars each for hanging files	74 3/4"	18"	25 1/2"	natural oak
	74 3/4"	18"	25 1/2"	mahogany
	74 3/4"	18"	25 1/2"	ebonized oak
	74 3/4"	18"	25 1/2"	pearwood
2544M Four storage cabinets with four adjustable shelves for use in two or more of the cabinets	74 3/4"	18"	25 1/2"	white lacquer
	74 3/4"	18"	25 1/2"	natural oak
	74 3/4"	18"	25 1/2"	mahogany
	74 3/4"	18"	25 1/2"	ebonized oak
	74 3/4"	18"	25 1/2"	pearwood
2547M Four box drawers (each with one removable partition), one full-extension file drawer with two metal bars for hanging files. Two storage cabinets with two adjustable shelves for use in one or both cabinets	74 3/4"	18"	25 1/2"	natural oak
	74 3/4"	18"	25 1/2"	mahogany
	74 3/4"	18"	25 1/2"	ebonized oak
	74 3/4"	18"	25 1/2"	pearwood
2548M Four box drawers (each with one removable partition), one full-extension file drawer with two metal bars, two storage cabinets with two adjustable shelves for use in one or both cabinets	74 3/4"	18"	25 1/2"	natural oak
	74 3/4"	18"	25 1/2"	mahogany
	74 3/4"	18"	25 1/2"	ebonized oak
	74 3/4"	18"	25 1/2"	pearwood
2549M Four box drawers (each with one removable partition), four full-extension file drawers with two metal bars each for hanging files	74 3/4"	18"	25 1/2"	natural oak
	74 3/4"	18"	25 1/2"	mahogany
	74 3/4"	18"	25 1/2"	ebonized oak
	74 3/4"	18"	25 1/2"	pearwood

Order Code

<i>Example:</i>	2543M-CO-P-MN
2543M	Florence Knoll credenza, four position
CO	Satin Chrome
P	Pearwood body
MN	Nero Marquina top
2543x	Optional locking system

Florence Knoll credenzas are part of a collection. Please refer to Florence Knoll lounge seating on page 134 and table desks, conference and low tables beginning on page 310.

Ordering Information

- Specify:*
1. Pattern number
 2. Base finish option
 3. Body veneer selection
 4. Top marble or wood selection
 5. Optional central locking system (upcharge \$785)
- Base finishes:*
Polished Chrome (suffix C)
Satin Chrome (suffix CO)
- Body and top veneers/lacquer:*
Ebonyed Oak (suffix E)
Medium Brown Mahogany (suffix M7)
Medium Red Mahogany (suffix M9)
Natural Oak (suffix O)
Pearwood (suffix P)
White Lacquer (on 2544M only: suffix 2)
- Polished Coated marble top finishes:*
Arabescato: white-grey (suffix MA)
Calacatta: white-grey/beige (suffix MC)
Carrara: white-grey (suffix GC)
Empire Beige: beige (suffix GB)

- Grey Marble: light grey (suffix GG)
Nero Marquina: black (suffix MN)
Verde Alpi: green (suffix MV)
- Satin Coated marble top finishes:*
Arabescato: white-grey (suffix MAS)
Calacatta: white-grey/beige (suffix MCS)
Carrara: white-grey (suffix GCS)
Empire Beige: beige (suffix GBS)
Grey Marble: light grey (suffix GGS)
Nero Marquina: black (suffix MNS)
Verde Alpi: green (suffix MVS)
- Natural marble top finishes:*
Carrara: white-grey (suffix NGC)

Central locking:
Optional central locking secures drawers and doors instantly with one single key lock located in credenza top (left front side). Add proper lock suffix to item number at an additional cost of \$785. See chart below for ordering information.

Credenza pattern no.	Central locking system pattern no.
2453M	2543X
2544M	2544X
2547M	2547X
2548M	2548X
2549M	2549X

Note:
KnollStudio logo and Florence Knoll's signature are stamped on each piece.

For weight information, please contact your KnollStudio representative.

Maintenance:
See pages 28-29.

Construction

Base:
Welded square steel tube in polished chrome finish. Optional satin chrome finish. Adjustable glides.

Body:
Wood veneer sides and matching back panel in oak, pearwood, or mahogany. Oak, mahogany and pearwood finished with transparent polyurethane coat. Only 2544M storage cabinet available in white lacquer.

Top:
3/4" thick marble coated with transparent polyester to help eliminate use-associated stains. Squared edge detail. 3/4" wood top matching body available. Wood tops finished with transparent polyurethane coat.



Note:
Marbles with a coating will yellow over time.

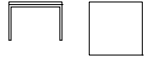
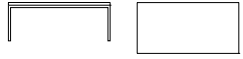

Front:
Drawer and door fronts in same wood veneers or lacquer finish as body. All have polished aluminum pulls, top flush mounted storage doors with magnetic closures. Location A storage hinges open from left. Location B storage hinges open from right. Other hinges open from right. Other hinging available as special. Pull out drawers with smooth-glide extension slides. Drawer and storage have matching veneer inside.

pattern no.	wood top/ polished base	(MN, MNS, MA, MAS, MC, MCS MV, MVS, GG, GGS) marble top/ polished base	(GC, GCS, GB, GBS) marble top/ polished base	(NGC) marble top/ polished base	wood top/ satin base	(MN, MNS, MA, MAS, MC, MCS MV, MVS, GG, GGS) marble top/ satin base	(GC, GCS, GB, GBS) marble top/ satin base	(NGC) marble top/ satin base
2543M-()-O-()-()	\$20,768.	\$22,680.	\$22,680.	\$22,163.	\$21,020.	\$22,932.	\$22,932.	\$22,417.
2543M-()-(M7,M9)-()-()	22,067.	23,911.	23,911.	23,369.	22,317.	24,165.	24,165.	23,623.
2543M-()-E-()-()	23,213.	25,143.	25,143.	24,580.	23,463.	25,394.	25,394.	24,833.
2543M-()-P-()-()	27,658.	27,658.	27,658.	27,104.	27,910.	27,912.	27,912.	27,357.
2544M-()-2-()-()	n/a	18,488.	18,488.	17,822.	n/a	18,742.	18,742.	18,078.
2544M-()-O-()-()	13,546.	15,163.	15,163.	14,721.	13,800.	15,418.	15,418.	14,975.
2544M-()-(M7,M9)-()-()	14,423.	15,984.	15,984.	15,522.	14,678.	16,239.	16,239.	15,776.
2544M-()-E-()-()	15,175.	16,805.	16,805.	16,330.	15,427.	17,058.	17,058.	16,585.
2544M-()-P-()-()	18,488.	18,445.	18,445.	18,016.	18,742.	18,699.	18,699.	18,269.
2547M-()-O-()-()	17,159.	18,936.	18,936.	18,454.	17,410.	19,188.	19,188.	18,705.
2547M-()-(M7,M9)-()-()	18,178.	19,894.	19,894.	19,393.	18,432.	20,148.	20,148.	19,646.
2547M-()-E-()-()	19,070.	20,847.	20,847.	20,327.	19,321.	21,098.	21,098.	20,577.
2547M-()-P-()-()	22,938.	22,938.	22,938.	22,449.	23,193.	23,192.	23,192.	22,700.
2548M-()-O-()-()	17,159.	18,936.	18,936.	18,454.	17,410.	19,188.	19,188.	18,705.
2548M-()-(M7,M9)-()-()	18,178.	19,894.	19,894.	19,393.	18,432.	20,148.	20,148.	19,646.
2548M-()-E-()-()	19,070.	20,847.	20,847.	20,327.	19,321.	21,098.	21,098.	20,577.
2548M-()-P-()-()	22,938.	22,938.	22,938.	22,449.	23,193.	23,192.	23,192.	22,700.
2549M-()-O-()-()	20,000.	21,857.	21,857.	21,332.	20,254.	22,110.	22,110.	21,588.
2549M-()-(M7,M9)-()-()	21,302.	23,086.	23,086.	22,542.	21,556.	23,341.	23,341.	22,797.
2549M-()-E-()-()	22,446.	24,317.	24,317.	23,732.	22,699.	24,573.	24,573.	23,987.
2549M-()-P-()-()	26,891.	26,891.	26,891.	26,336.	27,145.	27,146.	27,146.	26,591.

Florence Knoll Coffee Tables

	description	w	d	h	weight	top	
<p><i>Designer(s):</i> Florence Knoll, 1954</p> <p><i>Award(s):</i> American Institute of Interior Designers First Award, USA, 1954</p> 	<p>2510T Square coffee table</p> 	23 1/2"	23 1/2"	17"	50 lbs.	clear glass	
		23 1/2"	23 1/2"	17"	50 lbs.	white or black glass	
		23 1/2"	23 1/2"	17"	65 lbs.	natural marble	
		23 1/2"	23 1/2"	17"	65 lbs.	coated marble	
		23 1/2"	23 1/2"	17"	33 lbs.	veneer	
		23 1/2"	23 1/2"	17"	65 lbs.	coated marble	
		23 1/2"	23 1/2"	17"	65 lbs.	coated marble	
		23 1/2"	23 1/2"	17"	33 lbs.	pearwood	
		23 1/2"	23 1/2"	17"	65 lbs.	coated marble	
		23 1/2"	23 1/2"	17"	65 lbs.	coated marble	
		23 1/2"	23 1/2"	17"	67 lbs.	granite	
		23 1/2"	23 1/2"	17"	65 lbs.	natural marble	
		<p>2511T Rectangular coffee table</p> 	45"	22 1/2"	17"	76 lbs.	clear glass
			45"	22 1/2"	17"	104 lbs.	coated marble
45"	22 1/2"		17"	104 lbs.	natural marble		
45"	22 1/2"		17"	104 lbs.	coated marble		
45"	22 1/2"		17"	45 lbs.	veneer		
45"	22 1/2"		17"	104 lbs.	coated marble		
45"	22 1/2"		17"	45 lbs.	pearwood		
45"	22 1/2"		17"	104 lbs.	coated marble		
45"	22 1/2"		17"	104 lbs.	coated marble		
45"	22 1/2"		17"	104 lbs.	coated marble		
45"	22 1/2"		17"	106 lbs.	granite		
45"	22 1/2"		17"	104 lbs.	natural marble		

pattern no.	polished chrome (suffix C)	satin chrome (suffix CO)
2510T(-)G2 	\$1,151.	\$1,242.
2510T(-)C1, C2	1,586.	1,674.
2510T(-)(-)(NGC)	2,011.	2,098.
2510T(-)(-)(MN, MNS, MA, MAS, GG, GGS)	2,116.	2,204.
2510T(-)(-)(LO, LWA, D, V314)	2,199.	2,285.
2510T(-)(-)(GC, GCS, GB, GBS)	2,217.	2,306.
2510(-)(-)(MG, MGS)	2,282.	2,368.
2510T(-)(-)(P)	2,386.	2,472.
2510T(-)(-)(MC, MCS)	2,415.	2,502.
2510(-)(-)(ME, MES)	2,473.	2,559.
2510T(-)(-)(MV, MVS)	2,802.	2,889.
2510T(-)(-)(GA)	3,607.	3,694.
2510T(-)(-)(NC)	3,912.	4,000.
2511T(-)G2 	1,594.	1,720.
2511T(-)(-)(MG, MGS)	2,369.	2,491.
2511T(-)(-)(NGC)	2,682.	2,808.
2511T(-)(-)(MN, MNS, MA, MAS, GG, GGS)	2,896.	3,021.
2511T(-)(-)(LO, LWA, D, V314)	2,918.	3,044.
2511T(-)(-)(GC, GCS, GB, GBS)	3,036.	3,162.
2511T(-)(-)(P)	3,177.	3,302.
2511T(-)(-)(MC, MCS)	3,305.	3,432.
2511T(-)(-)(MV, MVS)	3,904.	4,030.
2511(-)(-)(ME, MES)	4,222.	4,344.
2511T(-)(-)(GA)	4,830.	4,958.
2511T(-)(-)(NC)	5,560.	5,686.

Order Code	Ordering Information
<i>Example:</i> 2510T-C-G2	<i>Base finishes:</i>
2510T Florence Knoll square coffee table	 Polished Chrome (suffix C) Satin Chrome (suffix CO)
C Polished Chrome	<i>Glass top finishes:</i>
G2 Clear glass	Black Glass (suffix C1)  Clear Glass (suffix G2) White Glass (suffix C2)
<i>Note:</i> Florence Knoll coffee tables are part of a collection. Please refer to Florence Knoll lounge seating on page 134 and desks and credenzas beginning on page 310.	<i>Veneer finishes:</i> Ebony Walnut (suffix D) Light Oak (suffix LO) Light Walnut (suffix LWA) Reff Dark Cherry (suffix V314)
<i>Specify:</i> 1. Pattern number 2. Base finish option 3. Top selection	<i>Pearwood finish:</i> Pearwood (suffix P)
	<i>Polished Coated marble top finishes:</i> Arabescato: white-grey (suffix MA) Calacatta: white-grey/beige (suffix MC) Carrara: white-grey (suffix GC) Empire Beige: beige (suffix GB) Espresso: dark brown (suffix ME) Grey Marble: light grey (suffix GG) Grigio Marquina: warm grey (suffix MG) Nero Marquina: black (suffix MN) Verdi Alpi: green (suffix MV)
	<i>Granite top finish:</i> Black Andes: black (suffix GA)
	 <i>KnollStudio 20-Day Program:</i> The Florence Knoll 2510T and 2511T tables in polished chrome finish and clear glass top are available on the KnollStudio 20-Day program. For specific information, consult pages 30-33.
	<i>Note:</i> Wood finishes on Florence Knoll low tables differ from those on the table desk and credenzas.
	<i>Base:</i> Polished chrome-plated or satin chrome-plated steel.
	<i>Maintenance:</i> See pages 28-29.
	<i>Note:</i> KnollStudio logo and signature of Florence Knoll are stamped into the base.
	The Florence Knoll Coffee and End Tables in all finishes are Greenguard certified.

Construction
<i>Top:</i> 5/8" thick polished plate glass or coated marble with transparent polyester to help eliminate use-associated stains. 3/4" thick natural marble and granite top with protective sealer.
<i>Note:</i> Marbles with a coating will yellow over time.
<i>Wood Top:</i> Tops are constructed of veneered medium density fiberboard with a cathedral grain pattern in various toned or stained finishes for light oak, light walnut, reff dark cherry and pearwood. Ebony walnut features a black stain on walnut substrate. Tops are 3/4" thick. Base and Top ship separately. Top is attached to base with wood screws that are enclosed in hardware packet.

Florence Knoll End Tables

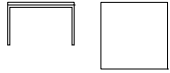
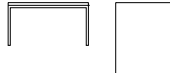
	description	w	d	h	weight	top	
<p><i>Designer(s):</i> Florence Knoll, 1954</p> <p><i>Award(s):</i> American Institute of Interior Designers First Award, USA, 1954</p> 	<p>2515T Square end table</p> 	29 1/2"	29 1/2"	19"	71 lbs.	clear glass	
		29 1/2"	29 1/2"	19"	95 lbs.	natural marble	
		29 1/2"	29 1/2"	19"	95 lbs.	coated marble	
		29 1/2"	29 1/2"	19"	95 lbs.	coated marble	
		29 1/2"	29 1/2"	19"	44 lbs.	veneer	
		29 1/2"	29 1/2"	19"	95 lbs.	coated marble	
		29 1/2"	29 1/2"	19"	44 lbs.	pearwood	
		29 1/2"	29 1/2"	19"	95 lbs.	coated marble	
		29 1/2"	29 1/2"	19"	95 lbs.	coated marble	
		29 1/2"	29 1/2"	19"	95 lbs.	coated marble	
		29 1/2"	29 1/2"	19"	96 lbs.	granite	
		29 1/2"	29 1/2"	19"	95 lbs.	natural marble	
		<p>2517T Square end table</p> 	35 1/2"	35 1/2"	19"	93 lbs.	clear glass
			35 1/2"	35 1/2"	19"	128 lbs.	natural marble
			35 1/2"	35 1/2"	19"	53 lbs.	veneer
35 1/2"	35 1/2"		19"	128 lbs.	coated marble		
35 1/2"	35 1/2"		19"	53 lbs.	pearwood		
35 1/2"	35 1/2"		19"	128 lbs.	coated marble		
35 1/2"	35 1/2"		19"	128 lbs.	coated marble		
35 1/2"	35 1/2"		19"	128 lbs.	coated marble		
35 1/2"	35 1/2"		19"	128 lbs.	coated marble		
35 1/2"	35 1/2"		19"	128 lbs.	coated marble		
35 1/2"	35 1/2"		19"	131 lbs.	granite		
35 1/2"	35 1/2"		19"	128 lbs.	natural marble		

pattern no.	polished chrome (suffix C)	satin chrome (suffix CO)
2515T (-)G2	\$1,539.	\$1,629.
2515T (-)(NGC)	2,368.	2,461.
2515T (-)(MN, MNS, MA, MAS, GG, GGS)	2,533.	2,625.
2515T (-)(GC, GCS, GB, GBS)	2,654.	2,748.
2515T (-)(LO, LWA, D, V314)	3,014.	3,105.
2515T (-)(MG, MGS)	3,096.	3,186.
2515T (-)(P)	3,273.	3,363.
2515T (-)(MC, MCS)	3,473.	3,564.
2515T (-)(MV, MVS)	3,522.	3,612.
2515 (-)(ME, MES)	3,701.	3,791.
2515T (-)(GA)	4,621.	4,711.
2515T (-)(NC)	5,156.	5,238.
2517T (-)G2	1,790.	1,915.
2517T (-)(NGC)	3,080.	3,207.
2517T (-)(LO, LWA, D, V314)	3,140.	3,266.
2517T (-)(MN, MNS, MA, MAS, GG, GGS)	3,376.	3,500.
2517T (-)(P)	3,400.	3,526.
2517T (-)(GC, GCS, GB, GBS)	3,536.	3,663.
2517T (-)(MG, MGS)	4,064.	4,185.
2517T (-)(MV, MVS)	4,409.	4,534.
2517T (-)(MC, MCS)	4,623.	4,750.
2517T (-)(ME, MES)	4,829.	4,949.
2517T (-)(GA)	5,506.	5,633.
2517T (-)(NC)	6,278.	6,403.

Order Code	Ordering Information
<p><i>Example:</i> 2517T-CO-GS</p> <p>2517T Florence Knoll square end table</p> <p>CO Satin Chrome</p> <p>GS Cedar Stone</p>	<p><i>Base finishes:</i> Polished Chrome (suffix C) Satin Chrome (suffix CO)</p> <p><i>Glass top finishes:</i> Clear Glass (suffix G2)</p> <p><i>Veneer finishes:</i> Ebonized Walnut (suffix D) Light Oak (suffix LO) Light Walnut (suffix LWA) Reff Dark Cherry (suffix V314)</p> <p><i>Pearwood finish:</i> Pearwood (suffix P)</p>
<p><i>Note:</i> Florence Knoll end tables are part of a collection. Please refer to Florence Knoll lounge seating on page 134 and desks and credenzas beginning on page 310.</p> <p><i>Specify:</i> 1. Pattern number 2. Base finish option 3. Top selection</p>	<p><i>Polished Coated marble top finishes:</i> Arabescato: white-grey (suffix MA) Calacatta: white-grey/beige (suffix MC) Carrara: white-grey (suffix GC) Empire Beige: beige (suffix GB) Espresso: dark brown (suffix ME) Grey Marble: light grey (suffix GG) Grigio Marquina: warm grey (suffix MG) Nero Marquina: black (suffix MN) Verdi Alpi: green (suffix MV)</p> <p><i>Satin Coated marble top finishes:</i> Arabescato: white-grey (suffix MAS) Calacatta: white-grey/beige (suffix MCS) Carrara: white-grey (suffix GCS) Empire Beige: beige (suffix GBS) Espresso: dark brown (suffix MES) Grey Marble: light grey (suffix GGS) Grigio Marquina: warm grey (suffix MGS) Nero Marquina: black (suffix MNS) Verde Alpi: green (suffix MVS)</p> <p><i>Natural marble top finishes:</i> Calacatta: white-grey/beige (suffix NC) Carrara: white-grey (suffix NGC)</p> <p><i>Granite top finish:</i> Black Andes: black (suffix GA)</p>
	<p><i>Note:</i> Wood finishes on Florence Knoll low tables differ from those on the table desk and credenzas.</p> <p><i>Base:</i> Polished chrome-plated or satin chrome-plated steel.</p> <p><i>Maintenance:</i> See pages 28-29.</p> <p><i>Note:</i> KnollStudio logo and signature of Florence Knoll are stamped into the base.</p> <p>The Florence Knoll Coffee and End Tables in all finishes are Greenguard certified.</p>

Construction
<p><i>Top:</i> 3/8" thick polished plate glass or coated marble with transparent polyester to help eliminate use-associated stains. 1/4" thick natural marble and granite top with protective sealer.</p> <p><i>Note:</i> Marbles with a coating will yellow over time.</p> <p><i>Wood Top:</i> Tops are constructed of veneered medium density fiberboard with a cathedral grain pattern in various toned or stained finishes for light oak, light walnut, reff dark cherry and pearwood. Ebonized walnut features a black stain on walnut substrate. Tops are 3/4" thick. Tops contain threaded inserts and attach to base with screws.</p>

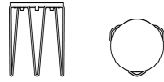

Florence Knoll

Hairpin™ Stacking Table

	description	w	d	h	base	weight
<i>Designer(s):</i> Florence Knoll, 1947	75 Hairpin stacking table 	13"	13"	18½"	Paint	7 lbs
		13"	13"	18½"	Chrome	7 lbs

pattern no.	colored laminate	woodgrain laminate
75-(-)()	\$305.	\$336.
75-(-)(C)	336.	367.

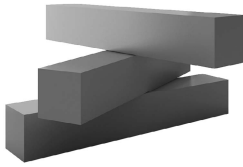
Order Code	Ordering Information	Construction
<i>Example:</i> 75-F1-W	<i>Colored Laminate Finishes:</i>	<i>Base:</i>
75 Hairpin stacking table	Black (suffix F1)	Base is constructed of bent cold rolled steel rods and powder coated paint finish or chrome plated. Stainless steel screws attach base to the table top.
F1 Black laminate	White (suffix F2)	
W White base	<i>Woodgrain Laminate Finishes:</i>	<i>Laminate Top:</i>
	Grey Ash (suffix 142)	MDF top is sandwiched between laminate layer with ABS edge. Woodgrain laminate tops will feature a matching woodgrain ABS edge. Three nylon bumpers underneath the top prevent scratches when tables are stacked.
	Light Ash (suffix 139)	
	Zebra (suffix 145)	<i>Note:</i>
<i>Specify:</i>	<i>Base Finishes:</i>	Tables stack up to 5 high.
1. Pattern number	Chrome (suffix C)	
2. Top selection	Black (suffix BL)	
3. Base selection	White (suffix W)	
	Blue (suffix BU)	
	Red (suffix RD)	
	Yellow (suffix YL)	
	Green (suffix GE)	
	<i>Maintenance:</i>	The Florence Knoll Hairpin Stacking Table is Greenguard certified.
	See pages 28-29.	

	description	w	d	h	weight
<p><i>Designer(s):</i> Rem Koolhaas, 2013</p> 	<p>04CTR Counter</p> 	94 1/2"	15 3/4"	47"	925 lbs.

pattern no.	list
04CTR-()	\$130,000.

Order Code

Example: **04CTR-845CC**

04CTR 04 Counter

845CC Red

Specify:

1. Pattern number
2. Solid core laminate selection

Ordering Information

Solid core laminate finishes:

Black (suffix 111CC)

Fog (suffix 128CC)

Folkstone (suffix 114CC)

Red (suffix 845CC)

Maintenance:

See pages 28-29.

Prior to Ordering:

Installation Requirements Package:

Please contact your KnollStudio sales representative to obtain a complete installation requirement package *before* submitting an order.

Spatial Considerations:

Please consider these specific spatial dimensions before ordering the 04 Counter:

- Individual beam dimensions: 94 1/2 inches length, 15 3/4 inches square width/height
- Height of the overall counter: 47 inches
- Clear circular footprint required: 13.6 foot diameter
- Total assembled weight: 925 lbs









Note:

Once installed, the 04 Counter is a permanent structure in your space, akin to building a wall. It cannot be easily removed to install flooring, lay a rug, etc. Please think through the alignment and underlayment prior to installation.

Site Flooring Requirements

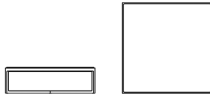
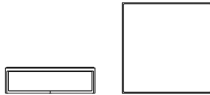
These site flooring requirements are solely the customer's responsibility and must be completed prior to installation:

- A minimum of 4" solid concrete floor foundation must be present at the installation site.
- The floor under the mounting plate should be level to within .05 inches
- The floor under the first box should be level to within .25 inches
- No electrical, plumbing, HVAC or reinforcements can be imbedded in the flooring
- Raised floors are not acceptable
- If there is floor covering, there can be no gap between the floor covering and the concrete

	description	w	d	h	base
<i>Designer(s):</i> Marc Krusin, 2012	MK11 Square side table 	18"	18"	18"	Ash, Beech & Oak
		18"	18"	18"	Walnut
	MK12 Square side table 	18"	18"	22"	Ash, Beech & Oak
		18"	18"	22"	Walnut
	MK13 Square end table 	24"	24"	14"	Ash, Beech & Oak
		24"	24"	14"	Walnut
	MK14 Square coffee table 	36"	36"	10"	Ash, Beech & Oak
		36"	36"	10"	Walnut
	MK15 Square coffee table 	36"	36"	14"	Ash, Beech & Oak
		36"	36"	14"	Walnut
	MK16 Rectangular coffee table 	40"	24"	14"	Ash, Beech & Oak
		40"	24"	14"	Walnut

pattern no	glass& laminare tops	veneer top	leather	GE, GES	MA, MAS, ME, MES, MG, MGS	MC, MCS	engineered stone (VB)
MK11-(-)(-)	\$1,176.	\$1,768.	\$1,992.	\$2,163.	\$2,270.	\$2,500.	\$2,092.
MK11-(-)-AW	1,319.	2,003.	2,168.	2,341.	2,448.	2,672.	2,276.
MK12-(-)(-)	1,187.	1,778.	2,003.	2,175.	2,281.	2,511.	2,116.
MK12-(-)-AW	1,334.	2,028.	2,181.	2,363.	2,470.	2,700.	2,306.
MK13-(-)(-)	1,448.	1,897.	2,270.	2,664.	2,801.	3,191.	2,855.
MK13-(-)-AW	1,684.	2,205.	2,566.	2,960.	3,097.	3,487.	3,150.
MK14-(-)(-)	1,969.	2,205.	3,468.	3,905.	4,426.	5,076.	5,081.
MK14-(-)-AW	2,163.	2,505.	3,717.	4,155.	4,674.	5,330.	5,336.
MK15-(-)(-)	1,969.	2,205.	3,468.	3,905.	4,426.	5,076.	5,081.
MK15-(-)-AW	2,163.	2,505.	3,717.	4,155.	4,674.	5,330.	5,336.
MK16-(-)(-)	2,103.	2,722.	3,706.	4,250.	5,103.	6,006.	3,898.
MK16-(-)-AW	2,187.	2,812.	3,795.	4,359.	5,211.	6,113.	4,001.

Order Code	Ordering Information		
<i>Example:</i> MK13-G2-A101	Base Finishes:	Top Finishes:	Veneer:
MK13 Square End Table	<i>Ash:</i> White Ash, suffix A101	<i>Laminate:</i> Bright White (suffix 118)	<i>Beech:</i> Beech (suffix B311) Bronzed Cherry (suffix B312A) Burnt Walnut (suffix B313) Deep Red Mahogany (suffix B328) Ebonized (suffix BE) Light Cherry (suffix B315) Medium Cherry (suffix B319) Medium Red Mahogany (suffix BR) Medium Walnut (suffix B323) Natural Beech (suffix BN)
G2 Clear Glass	<i>Oak:</i> Natural Oak (suffix ON) Ebonized Oak (suffix OE) Fumed Oak (suffix OF)	<i>Glass:</i> Clear Glass (suffix G2)	
A101 White ash base	<i>Walnut:</i> American Walnut (suffix AW)	<i>Ash:</i> White Ash (suffix A101)	
<i>Note:</i> When specifying veneer tops, the base finish matches top. Contrasting top and base finish is not a standard option	<i>Beech:</i> Beech (suffix B311) Bronzed Cherry (suffix B12A) Burnt Walnut (suffix B313) Deep Red Mahogany (suffix B328) Ebonized (suffix BE) Light Cherry (suffix B315) Light Walnut (suffix B411) Medium Cherry (suffix B319) Medium Red Mahogany (suffix BR) Medium Walnut (suffix B323) Natural Beech (suffix BN)	<i>Walnut:</i> American Walnut (suffix AW)	
<i>Specify:</i> 1. Pattern number 2. Top Finish 3. Base Finish			

Construction
<i>Leather:</i> <i>Spinneybeck Riva:</i> Anata Beccorosso (suffix RA1808) Aquila de Mare (suffix RA1813) Beccaccia de Mare (suffix RA1815) Black (suffix RABLK) Cavaliere d'Italia (suffix RA1804) Paggiarolo (suffix RA1809) Spatola (suffix RA1806) *CFA waived for this product line
<i>Frame:</i> Select American and European hard wood frames. Dowel and mortise and tenon construction.
<i>Marble and Glass Tops:</i> Inset 1/4" thick coated marbles in polished or satin polyester coating and clear tempered glass with radius corners. Tops rest within the frame.
<i>Veneer and Laminate Tops:</i> Constructed with MDF core with solid lumber edges. Laminate has painted filled edge. Face and back are veneer or laminate. Inset tops have threaded inserts to attach to frame.
<i>Engineered Stone:</i> Vetro Bianco (VB)
<i>Leather Tops:</i> Constructed with MDF core wrapped in select Riva leather in various colors.
<i>Finish:</i> Beech, Catalyzed lacquer protective coating. Hand applied final wax coating. Ash, Oak, and Walnut with low sheen urethane protective coating. Hand applied final wax coating. Conversion varnish top coat.
<i>Glides:</i> Felt glides included with all bases for use on hard floor surfaces.

Lucia Mercer
Mercer Table

	description	w	d	h	weight
<i>Designer(s):</i> Lucia Mercer, 1982	701T Mercer Table 	21 3/8"	13 1/2"	15"	243 lbs
		21 7/8"	13 1/2"	15"	243 lbs
		21 1/8"	13 1/2"	15"	243 lbs

Award(s):
IBD Award, USA, 1983



pattern no.	list
701T-MN	\$5,698.
701T-MC	7,528.
701T-MV	7,599.



Order Code	Ordering Information	Construction
<i>Example:</i> 701T	<i>Natural marble finishes:</i>	The Mercer Table is solid natural
701T	Nero Marquina: black (suffix MN)	(uncoated) marble.
MN	Calacatta: white-grey/beige (suffix MC)	<i>Note:</i>
	Verde Alpi: green (suffix MV)	Top surface dimensions are 14.5" w



Specify:
1. Pattern number
2. Top selection

Maintenance:
See pages 28-29.

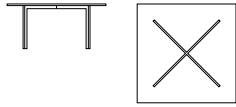
Ludwig Mies van der Rohe

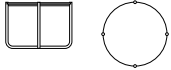
Barcelona® Table, MR Table

	description	w	d	h	weight	top	base
<p><i>Designer(s):</i> Ludwig Mies van der Rohe, 1930</p> 	<p>252 Barcelona table</p> 	40"	40"	17"	134 lbs.	Clear glass	Stainless steel
		40"	40"	18.5"	140 lbs.	Clear glass	Polished chrome
		40"	40"	17"	134 lbs.	Starphire glass	Stainless steel
		40"	40"	18.5"	140 lbs.	Starphire glass	Polished chrome
	<p>259TS MR table</p> 	28.5"		20.8"	37 lbs.	Clear glass	Stainless steel

pattern no.	
252	\$4,635.
252C 	2,791.
252-SFG	5,179.
252C-SFG	3,490.
259TS-G 	2,203.

Order Code

<i>Example:</i>	252C-SFG
252	Barcelona table
C	Polished Chrome
SFG	Starphire Glass

Note:
The Mies Barcelona and MR tables are part of a collection. Please refer to Mies side chairs and lounge seating beginning on page 182.

Specify:

1. Pattern number
2. Base finish option
3. Top selection

Ordering Information

Shipping:
Top and base of MR Tables ship in separate packages.

 *KnollStudio 20-Day Program:*
The Barcelona table in chrome with clear glass top and the MR table are available on the KnollStudio 20-day program. For specific information, consult pages 30-33.

Maintenance:
See pages 28-29.

Note:
The KnollStudio logo and signature of Ludwig Mies van der Rohe is stamped into the base of the MR and Barcelona tables.

The Barcelona Table and MR Table are Greenguard certified.

Construction

BARCELONA TABLE
Clear Glass Top:
3/4" thick top with a 1/8" wide beveled edge. Top and edges have a slight green tint.

Starphire™ Glass Top:
Starphire glass is more clear and luminous than regular glass. The low iron content gives glass a crystal quality. 1/8" bevel edge has an exceptionally clear character.

Stainless Steel Base:
Premium grade 202 bar stock stainless steel. Single piece construction ensures long-term durability. Frame hand-ground and hand-buffed to mirror finish.

Polished Chrome Base:
Hand-ground and hand-buffed to a mirror finish. Single piece construction.



Bumpers:
Polished Chrome table has black bumpers. Stainless steel table has white bumpers.

MR TABLE
Top:
1/2" thick clear polished plate glass.

Base:
Frame and legs are tubular and rectangular stainless steel welded together. Seamless construction buffed to a mirror finish.

Ludwig Mies van der Rohe

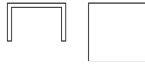
Krefeld™ Side and Coffee Table

	description	w	d	h	weight
Designer(s): Ludwig Mies van der Rohe, 1930 Design from the Mies van der Rohe Archive of The Museum of Modern Art	759 Square Table 	27 1/2"	27 1/2"	17 3/4"	35 lbs.
	760 Rectangular Coffee Table 	54"	27 1/2"	17 3/4"	63 lbs.



pattern number	clear oak	stained finishes
759-()	\$2,574.	\$2,650.
760-()	5,508.	5,671.

Order Code

<i>Example:</i>	759-OWE
759	Krefeld square coffee table
OWE	Wenge

Note:
The Mies Krefeld tables are part of a collection. Please refer to Mies side chairs and lounge seating beginning on page 182.

Specify:
1. Pattern number
2. Finish selection

Ordering Information

Table finishes:
Wenge (OWE)
Medium Cherry (OM)
Deep Red Mahogany (OF)
Light Walnut (OWA)
Clear Oak (OC)

Maintenance:
See pages 27-28.



Construction

Base and Top:
Oak with stained or clear oak finish.
Open pore finish. Black plastic glides.
Seamless connection between top and base.

Pascal Mourgue

Square and Rectangular Conference Tables

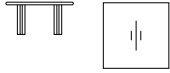
PVC-T edge

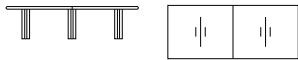
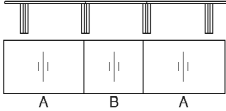
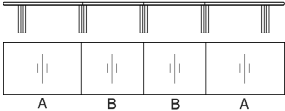
description	seating			w	d	h	weight	top
	capacity *	section	legs					
47TS15 square table 	8	1	4	60 1/4"	60 1/4"	28 3/4"	309 lbs.	Coated marble
	8	1	4	60 1/4"	60 1/4"	28 3/4"	309 lbs.	Natural marble
	8	1	4	60 1/4"	60 1/4"	28 3/4"	178 lbs.	Laminate
	8	1	4	60 1/4"	60 1/4"	28 3/4"	166 lbs.	Veneer
47TS20 rectangular table 	8	1	4	80"	48 1/2"	28 3/4"	328 lbs.	Coated marble
	8	1	4	80"	48 1/2"	28 3/4"	328 lbs.	Natural marble
	8	1	4	80"	48 1/2"	28 3/4"	187 lbs.	Laminate
	8	1	4	80"	48 1/2"	28 3/4"	175 lbs.	Veneer
47TS31 rectangular table 	10	2	6	120"	48 1/2"	28 3/4"	279 lbs.	Laminate
	10	2	6	120"	48 1/2"	28 3/4"	262 lbs.	Veneer
47TS48 rectangular table 	16	3	8	204"	48 1/2"	28 3/4"	450 lbs.	Laminate
	16	3	8	204"	48 1/2"	28 3/4"	425 lbs.	Veneer
47TS64 rectangular table 	22	4	10	268"	48 1/2"	28 3/4"	586 lbs.	Laminate
	22	4	10	268"	48 1/2"	28 3/4"	554 lbs.	Veneer



* Based on 26" wide arm chairs

Order Code	Ordering Information
<i>Example:</i> 47TS31-1-V315	<i>Leg finishes:</i>
47TS31 Pascal rectangular table	Matte Black Epoxy (suffix 1)
1 Black Epoxy	Polished Aluminum (suffix AP)
V315 Light Cherry Veneer	<i>Laminate finishes:</i>
<i>Example:</i> 47TSV15-AP-119-V315	Bright White (suffix 118)
47TSV15 Pascal square table, with veneer edge	Folkstone Grey (suffix 114)
AP Polished Aluminum	Fog (suffix 128)
119 Pumice	Jet Black (suffix 111)
V315 Light Cherry Veneer	Light Grey (suffix L)
	Pumice (suffix 119)
	Slate (suffix SL)
	Soft Grey (suffix 117)
	<i>Veneer/bullnose finishes:</i>
	American Cherry (suffix X)
	Ebonized Walnut (suffix D)
	Light Cherry (suffix V315)
	Maple (suffix K)
	Medium Red Mahogany (suffix Z)
	Natural Beech (suffix B)
	Warm Brown Walnut (suffix J)
	<i>Polished Coated marble finishes:</i>
	Carrara: white-grey (suffix GC)
	Empire Beige: beige (suffix GB)
	<i>Natural marble finishes:</i>
	Carrara: white-grey (suffix NGC)
	<i>Veneer edge:</i>
	For veneer edge, add 'V' after 4th digit.
	For example, for a 48 1/2" square table with veneer edge, specify 47TSV12.
	<i>Certified Wood:</i>
	Tables manufactured using FSC certified hardwoods and veneers and/or LEED compliant recyclable components are available through Custom Product Development. Extended leadtime and upcharge apply.
	<i>Maintenance:</i>
	See pages 28-29.
	<i>Note:</i>
	Polyester marble coating will yellow over time.
	<i>Standard size tables:</i>
	For additional standard size tables please consult your KnollStudio representative, dealer or Customer Service associate.
	<i>Special width tables:</i>
	For standard depth tables (42 1/4", 48 1/2", and 60 1/4"), you may determine list pricing on any special width between two standard sizes simply by identifying the next higher standard width tables, and add 5% to the standard list price.

Specify:

1. Pattern number
2. Leg finish selection
3. Top finish selection
4. Wood bullnose finish selection (for laminate tops only)

pattern no.	pvc edge	veneer edge (add V after 4th digit)	marble top
47TS15-(1, AP)-(GC, GB)			\$13,823.
47TS15-(1, AP)-(NGC)			11,606.
47TS15-(1, AP)-(-)(-)	4,738.	5,527.	
47TS15-(1, AP)-(-)	5,327.	6,509.	
47TS20-(1, AP)-(GC, GB)			13,968.
47TS20-(1, AP)-(NGC)			11,752.
47TS20-(1, AP)-(-)(-)	4,738.	5,327.	
47TS20-(1, AP)-(-)	5,527.	6,509.	
47TS31-(1, AP)-(-)(-)	7,299.	9,078.	
47TS31-(1, AP)-(-)	8,881.	10,851.	
47TS48-(1, AP)-(-)(-)	12,963.	15,389.	
47TS48-(1, AP)-(-)	16,968.	19,141.	
47TS64-(1, AP)-(-)(-)	14,909.	18,763.	
47TS64-(1, AP)-(-)	21,112.	23,678.	

Construction		
<p><i>Combining tables:</i> If individual tables are purchased with the intent of placing them contiguously, they should be quoted for flitch or book match. When desired specifically for combination, note that information on the order so that bullnose edges and legs at each table junction are removable. Leveling strip slides into slots at edges. Legs connect into inserts that span tops. Bullnose edges store for future retrieval and separation.</p> <p><i>Special sizes and finishes:</i> For all other sizes and for special finishes, consult your KnollStudio representative, dealer, or Customer Services for information.</p> <p><i>Legs:</i> Extruded aluminum leg in black epoxy or polished aluminum finish. Multiple sectioned tables have two legs bridging each section, plus two legs at each end.</p> <p><i>Marble top:</i> 13/16" thick marble coated with transparent polyester to help eliminate use-associated stains.</p>	<p><i>Laminate and wood tops:</i> Tops are 1 1/8" thick. Wood tops are cross-veneered. Tops available with black semi-gloss extruded PVC-T mold bullnose edge or stained solid wood bullnose edge. For PVC-T bullnose, short ends of rectangular table have a wood bullnose with a black semi-gloss paint to match the PVC-T edges.</p> <p><i>Glides:</i> Adjustable nylon, black epoxy finish.</p> <p><i>Shipping:</i> Top and base shipped in separate pieces; assembly required.</p>	<p><i>To assemble:</i> Legs connect into predrilled inserts using mounting hardware (included).</p>  <p><i>Bullnose edge detail:</i></p> 

Pascal Mourgue

Round and Racetrack Conference Tables

PVC-T edge

Designer(s):
Pascal Mourgue, 1985

Award(s):
The Roscoe Commendation, USA
1985; IBD Product Design Award,
1985; Corporate Design and
Reality Product Design Award,
1986



description	seating capacity *	section	legs	w	d	h	weight	top	pvc edge		veneer edge (add V after 4th digit)		marble top	
47TR15 round table 	7	1	4	60 1/4"		28 3/4"	250 lbs.	Coated marble						\$11,098.
	7	1	4	60 1/4"		28 3/4"	250 lbs.	Natural marble					9,413.	
	7	1	4	60 1/4"		28 3/4"	147 lbs.	Laminate						
	7	1	4	60 1/4"		28 3/4"	138 lbs.	Veneer						
47TR24 racetrack table 	8	1	4	97"	48 1/2"	28 3/4"	605 lbs.	Coated marble						16,547.
	8	1	4	97"	48 1/2"	28 3/4"	605 lbs.	Natural marble					13,805.	
	8	1	4	97"	48 1/2"	28 3/4"	315 lbs.	Laminate						
	8	1	4	97"	48 1/2"	28 3/4"	313 lbs.	Veneer						
47TR26 racetrack table 	8	2	6	108"	48 1/2"	28 3/4"	380 lbs.	Laminate						
	8	2	6	108"	48 1/2"	28 3/4"	377 lbs.	Veneer						
47TR30 racetrack table 	10	2	6	120"	48 1/2"	28 3/4"	280 lbs.	Laminate						
	10	2	6	120"	48 1/2"	28 3/4"	262 lbs.	Veneer						
47TR50 racetrack table 	16	3	8	192"	60 1/4"	28 3/4"	510 lbs.	Laminate						
	16	3	8	192"	60 1/4"	28 3/4"	485 lbs.	Veneer						
47TR72 racetrack table 	6	1	4	84"	42 1/4"	28 3/4"	177 lbs.	Laminate						
	6	1	4	84"	42 1/4"	28 3/4"	165 lbs.	Veneer						

* Based on 26" wide arm chairs

Order Code	Ordering Information		
<i>Example:</i> 47TR26-1-K	<i>Specify:</i>	<i>Veneer/bullnose finishes:</i>	<i>Certified Wood:</i>
47TR26 Pascal racetrack table	1. Pattern number	American Cherry (suffix X)	Tables manufactured using FSC certified
1 Black Epoxy	2. Leg finish selection	Ebonized Walnut (suffix D)	hardwoods and veneers and/or LEED
K Maple Veneer	3. Top finish selection	Light Cherry (suffix V315)	compliant recyclable components are
<i>Example:</i> 47TRV15-AP-J	4. Wood bullnose finish selection (for laminate tops only)	Maple (suffix K)	available through Custom Product
47TRV15 Pascal round table, with veneer edge	<i>Leg finishes:</i>	Medium Red Mahogany (suffix Z)	Development. Extended leadtime and
AP Polished Aluminum	Matte Black Epoxy (suffix 1)	Natural Beech (suffix B)	upcharge apply.
J Warm Brown Walnut Veneer	Polished Aluminum (suffix AP)	Warm Brown Walnut (suffix J)	<i>Maintenance:</i>
	<i>Laminate finishes:</i>	<i>Polished Coated marble finishes:</i>	See pages 28-29.
	Bright White (suffix 118)	Carrara: white-grey (suffix GC)	<i>Note:</i>
	Fog (suffix 128)	Empire Beige: beige (suffix GB)	Polyester marble coating will yellow over
	Folkstone Grey (suffix 114)	<i>Natural marble finishes:</i>	time.
	Jet Black (suffix 111)	Carrara: white-grey (suffix NGC)	The Pascal Table with Laminate top and
	Light Grey (suffix L)	<i>Veneer edge:</i>	PVC edge is Greenguard certified.
	Pumice (suffix 119)	For veneer edge, add 'V' after 4th digit.	
	Soft Grey (suffix 117)	For example, for a 48 1/2" round table,	
	Slate (suffix SL)	specify 47TRV12.	

pattern no.	pvc edge	veneer edge (add V after 4th digit)	marble top
47TR15-(1, AP)-(GC, GB)			\$11,098.
47TR15-(1, AP)-(NGC)			9,413.
47TR15-(1, AP)-(-)(-)	4,934.	6,509.	
47TR15-(1, AP)-(-)	5,527.	7,694.	
47TR24-(1, AP)-(GC, GB)			16,547.
47TR24-(1, AP)-(NGC)			13,805.
47TR24-(1, AP)-(-)(-)	5,723.	7,694.	
47TR24-(1, AP)-(-)	6,707.	9,078.	
47TR26-(1, AP)-(-)(-)	6,913.	9,291.	
47TR26-(1, AP)-(-)	8,210.	10,806.	
47TR30-(1, AP)-(-)(-)	8,210.	11,235.	
47TR30-(1, AP)-(-)	10,806.	13,397.	
47TR50-(1, AP)-(-)(-)	12,628.	17,958.	
47TR50-(1, AP)-(-)	20,528.	25,497.	
47TR72-(1, AP)-(-)(-)	5,131.	6,707.	
47TR72-(1, AP)-(-)	5,920.	8,287.	

Construction

Standard size tables:
For additional standard size tables please consult your KnollStudio representative, dealer or Customer Service associate.

Special width tables:
For standard depth tables (42 1/4", 48 1/2", and 60 1/4"), you may determine list pricing on any special width between two standard sizes simply by identifying the next higher standard width tables, and add 5% to the standard list price.

For example, if requesting an 80" w x 42 1/4" d table, you would identify the next wider table (84" w x 42 1/4" d) and add 5% to the list price of that standard size. Consult a KnollStudio representative for special Order Code.

Special sizes and finishes:
For all other sizes and for special finishes, consult your KnollStudio representative, dealer, or Customer Services for information.

Legs:
Extruded aluminum leg in black epoxy or polished aluminum finish. Multiple sectioned tables have two legs bridging each section, plus two legs at each end.

Laminate and wood tops:
Tops are 1 1/8" thick. Wood tops are cross-veneered. Tops available with black semi-gloss extruded PVC-T mold bullnose edge or stained solid wood bullnose edge. Bullnose edges on ends of racetrack tables are single, continuous arcs of wood.

Marble top:
13/16" thick marble coated with transparent polyester to help eliminate use-associated stains.

Glides:
Adjustable nylon, black epoxy finish.

Shipping:
Top and base shipped in separate pieces; assembly required.



To assemble:
Legs connect into predrilled inserts using mounting hardware (included).

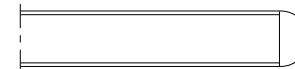

Bullnose edge detail:



Pascal Mourgue
Bullet Conference Tables
PVC-T edge

description	seating capacity *		section	legs	w	d	h	weight	top
	capacity	*							
47TR22 bullet table 	8	1	4	87 3/4"	48 1/2"	28 3/4"	356 lbs.	Coated marble	
	8	1	4	87 3/4"	48 1/2"	28 3/4"	356 lbs.	Natural marble	
	8	1	4	87 3/4"	48 1/2"	28 3/4"	201 lbs.	Laminate	
	8	1	4	87 3/4"	48 1/2"	28 3/4"	188 lbs.	Veneer	
47TR19 bullet table 	7	1	4	76"	60 1/4"	28 3/4"	353 lbs.	Coated marble	
	7	1	4	76"	60 1/4"	28 3/4"	353 lbs.	Natural marble	
	7	1	4	76"	60 1/4"	28 3/4"	200 lbs.	Laminate	
	7	1	4	76"	60 1/4"	28 3/4"	187 lbs.	Veneer	
									

Designer(s):
 Pascal Mourgue, 1985

Award(s):
 The Roscoe Commendation, USA
 1985; IBD Product Design Award,
 1985; Corporate Design and
 Reality Product Design Award,
 1986

pattern no.	pvc edge	veneer edge (add V after 4th digit)	marble top
47TR22-(1, AP)-(GC, GB)			\$14,467.
47TR22-(1, AP)-(NGC)			12,147.
47TR22-(1, AP)-(-)(-)	5,403.	7,299.	
47TR22-(1, AP)-(-)	5,920.	8,287.	
47TR19-(1, AP)-(GC, GB)			15,346.
47TR19-(1, AP)-(NGC)			12,848.
47TR19-(1, AP)-(-)(-)	5,403.	7,299.	
47TR19-(1, AP)-(-)	5,920.	8,287.	



* Based on 26" wide arm chairs

Order Code	Ordering Information
<i>Example:</i> 47TR19-AP-111	<i>Specify:</i>
47TR19 Pascal bullet table	1. Pattern number
AP Polished Aluminum	2. Leg finish selection
111 Jet Black Laminat	3. Top finish selection
	4. Wood bullnose finish selection (for laminate tops only)
<i>Example:</i> 47TRV22-1-111-B	<i>Leg finishes:</i>
47TRV22 Pascal bullet table, with veneer edge	Matte Black Epoxy (suffix I)
1 Black Epoxy	Polished Aluminum (suffix AP)
111 Jet Black Laminat	
B Natural Beech Veneer	
	<i>Laminate finishes:</i>
	Bright White (suffix 118)
	Fog (suffix 128)
	Jet Black (suffix 111)
	Light Grey (suffix L)
	Pumice (suffix 119)
	Slate (suffix SL)
	<i>Laminate finishes, continued:</i>
	Folkstone Grey (suffix 114)
	Soft Grey (suffix 117)
	<i>Veneer/bullnose finishes:</i>
	American Cherry (suffix X)
	Ebonized Walnut (suffix D)
	Light Cherry (suffix V315)
	Maple (suffix K)
	Medium Red Mahogany (suffix Z)
	Natural Beech (suffix B)
	Warm Brown Walnut (suffix J)
	<i>Polished Coated marble finishes:</i>
	Carrara: white-grey (suffic GC)
	Empire Beige: beige (suffix GB)
	<i>Natural marble finishes:</i>
	Carrara: white-grey (suffix NGC)
	<i>Veneer edge:</i>
	For veneer edge, add "V" after 4th digit.
	For example, for a 204" x 60 1/4" rectangular table with veneer edge, specify 47TSV52.

Construction

<i>Certified Wood:</i> Tables manufactured using FSC certified hardwoods and veneers and/or LEED compliant recyclable components are available through Custom Product Development. Extended leadtime and upcharge apply.	<i>Standard size tables:</i> For additional standard size tables please consult your KnollStudio representative, dealer or Customer Service associate.	<i>Special sizes and finishes:</i> For all other sizes and for special finishes, consult your KnollStudio representative, dealer, or Customer Services for information.	<i>Marble top:</i> 1 1/16" thick marble coated with transparent polyester to help eliminate use-associated stains.
<i>Maintenance:</i> See pages 28-29.	<i>Special width tables:</i> For standard depth tables (42 3/4", 48 1/2", and 60 1/4"), you may determine list pricing on any special width between two standard sizes simply by identifying the next higher standard width tables, and add 5% to the standard list price.	<i>Legs:</i> Extruded aluminum leg in black epoxy or polished aluminum finish. Multiple sectioned tables have two legs bridging each section, plus two legs at each end.	<i>Glides:</i> Adjustable nylon, black epoxy finish.
<i>Note:</i> Polyester marble coating will yellow over time.	<i>Note:</i> For example, if requesting an 80" w x 42 3/4" d table, you would identify the next wider table (84" w x 42 3/4" d) and add 5% to the list price of that standard size. Consult a KnollStudio representative for special Order Code.	<i>Laminate and wood tops:</i> Tops are 1 1/8" thick. Wood tops are cross-veneered. Tops available with black semi-gloss extruded PVC-T mold bullnose edge or stained solid wood bullnose edge. Bullnose edges on ends of racetrack tables are single, continuous arcs of wood.	<i>Shipping:</i> Top and base shipped in separate pieces; assembly required.
The Pascal Table with Laminate top and PVC edge is Greenguard certified.			<i>To assemble:</i> Legs connect into predrilled inserts using mounting hardware (included).

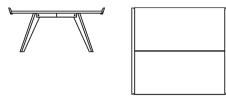
George Nakashima *Splay-Leg Table and Tray*

	description	w	d	h	weight
	N10 Splay-Leg Table 	37 1/4"	34 1/4"	17 1/2"	33 lbs.
	N20 Tray 	21 3/8"	16"	1 3/4"	5 lbs.

Designer(s):
George Nakashima, 1946

pattern no.	
N10-()-AW	\$2,913.
N20-DF-()	633.

Order Code	Ordering Information	Construction
Specify: N10-HK-AW	<i>Finishes, table only:</i> American Walnut (suffix AW) Hickory (suffix HK)	<i>TABLE:</i> <i>Top:</i> Tops are veneered with reverse slip-matched cathedral pattern, matching solid wood edge in clear low-sheen finish.
N10 Splay-Leg Table		
HK Hickory	<i>Finishes, tray only:</i> Brazilian Santos (suffix BS) Douglas Fir (suffix DF) Wenge (suffix WG)	<i>TRAY:</i> <i>Top:</i> Tops are constructed of solid Douglas Fir lumber that is quarter-cut and finished in a clear low-sheen finish. <i>Edge detail:</i> Available in two finishes: solid Brazilian Santos; solid Wenge. Edge details are joined to top with mortise and tenon joints.
AW American Walnut		
Specify: N20-DF-BS		
N20 Tray		
DF Douglas Fir	<i>Maintenance:</i> See pages 28-28.	<i>Legs, apron and edge detail:</i> Solid American Walnut. Mortise and tenon joints with solid brass hardware. Nylon glides. Edge detail finish is available in American Walnut only.
BS Brazilian Santos		

Note:
The Splay-Leg Table and Tray are part of a collection. Please refer to the Straight chair on page 200.

For Splay-Leg Table, specify:

1. Pattern number
2. Primary finish
3. Edge detail finish

For Splay-Leg Tray, specify:

1. Pattern number
2. Tray finish
3. Edge detail finish

Note:
Each table and tray features George Nakashima's signature under the table top.

The Splay-Leg Table is Greenguard certified.

Isamu Noguchi
Cyclone™ Dining and Side Tables

Designer(s):
Isamu Noguchi, 1954



description	w	d	h	weight	top	base
311 Cyclone Dining table 	36"		28"	89 lbs.	Black laminate	Cast iron black
	36"		28"	89 lbs.	White laminate	Cast iron black
	36"		28"	89 lbs.	Veneer	Cast iron black
	36"		28"	89 lbs.	Rosewood	Cast iron black
312 Cyclone Dining table 	42"		28"	97 lbs.	Black laminate	Cast iron black
	42"		28"	97 lbs.	White laminate	Cast iron black
	42"		28"	97 lbs.	Veneer	Cast iron black
	42"		28"	97 lbs.	Rosewood	Cast iron black
87 Side table 	24"		20"	31 lbs.	Black laminate	Cast iron black
	24"		20"	31 lbs.	White laminate	Cast iron black
	24"		20"	31 lbs.	Veneer	Cast iron black
	24"		20"	31 lbs.	Rosewood	Cast iron black

pattern no.	list
311-F1	\$3,299.
311-F2	3,299.
311-(D, LO, LWA)	3,567.
311-RO	3,734.
312-F1	3,623.
312-F2	3,623.
312-(D, LO, LWA)	3,946.
312-RO	4,183.
87-F1	2,176.
87-F2	2,176.
87-(D, LO, LWA)	2,418.
87-RO	2,494.

Order Code

Example:	312-F2
312	Cyclone dining table
F2	White Laminate top

Specify:

1. Pattern number
2. Top finish selection

Ordering Information

Laminate top finish:
Black (F1)
 White (F2)

Wood Veneer Top Finishes:
Ebonized Walnut (D)
Light Oak (LO)
Light Walnut (LWA)
Rosewood (RO)

KnollStudio 20-Day Program:
The Noguchi table is available on the KnollStudio 20-day program in round 36" with a white laminate top. For more specific information, please consult pages 30-33.

Note:
Each table features a signature plate under the table top with the KnollStudio logo and Isamu Noguchi's signature.

Maintenance:
See pages 28-29.

Note:
The Cyclone Table is Greenguard certified.





Construction

Noguchi table top:
Top is laminate or wood veneer with a natural birch edge. Top is 0.8" thick.

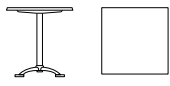
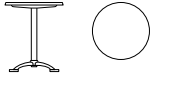

Noguchi table base:
Cast iron, black textured powder-coat.

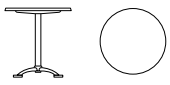

Noguchi table column:
Steel wire column, chrome plated finish.

Jorge Pensi
Pensi Tables
Small Cafe and Bar Height Tables



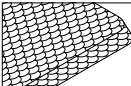
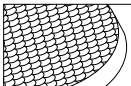

	description	top	w	d	h	weight
<i>Designer(s):</i> Jorge Pensi, 1988	29TS-27 Square café table 	Disks, wrapped edge	27 1/2"	27 1/2"	28 1/4"	35 lbs.
		Metallic Trespa, natural black edge	27 1/2"	27 1/2"	28 1/4"	32 lbs.
<i>Award(s):</i> First Place, Sidi Selection, Valencia, Spain, 1988; "Delta Plate" of ADI FAD, 1988; Design Center Stuttgart Award, W. Germany, 1990	29TR-23 Round café table 	Disks, wrapped edgeband	23 3/8"		28 1/4"	25 lbs.
		Metallic Trespa, natural black edge	23 3/8"		28 1/4"	23 lbs.
	29TR-27 Round café table 	Disks, wrapped edge	27 1/2"		28 1/4"	31 lbs.
		Metallic Trespa, natural black edge	27 1/2"		28 1/4"	27 lbs.
	29TR-H-23 Bar-height café table 	Disks, wrapped edge	23 3/8"		43 1/5"	26 lbs.
		Metallic Trespa, natural black edge	23 3/8"		43 1/5"	24 lbs.

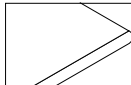
pattern no.	
29TS-27-DE	\$1,709.
29TS-27-LM	2,816.
29TR-23-DE	1,552.
29TR-23-LM	2,164.
29TR-27-DE 	1,709.
29TR-27-LM	2,816.
29TR-H-23-DE	1,906.
29TR-H23-LM	2,573.

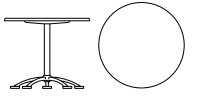
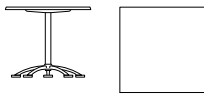

Order Code	Ordering Information	Construction
<i>Example:</i> 29TS-27-DE	<i>Table top finishes:</i>  Disks, wrapped edge * (suffix DE) Metallic Trespa (suffix LM) *Disks pattern does not appear on edge.	 <i>KnollStudio 20-Day Program:</i> Pensi tables are available on the KnollStudio 20-day program in a round 23" bar height size with concentric circle finish and in the round 27" size with disks finish. For specific information, please consult pages 30-33.
29TS Pensi table, square top	<i>Note:</i> The Pensi Tables are available in the United States only.	<i>Top:</i> Two stainless steel finishes: acid-etched pattern of concentric circles; sanded pattern of scalloped, compact disk-like, 1 1/4" wide circles; both with wrapped edge. One metallic Trespa option with a natural black phenolic edge. The Trespa metallic (LM) top finish is UV resistant, does not reflect heat, easy to clean and made of recyclable materials. The Trespa metallic (LM) top finish is ideal for outdoor use.
27 27" wide and deep		
DE Disks, wrapped edge		
<i>Note:</i> Pensi Tables are part of a collection. Please refer to Toledo chairs on page 204.		
<i>Specify:</i> 1. Pattern number 2. Table size 3. Top finish selection		

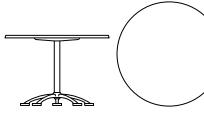

<i>Base:</i> Anodized and polished cast aluminum with 4 1/8" pad-like feet. Four-star base on cafe tables. Five-star base on bistro and dining tables. The central column is a polished and anodized aluminum round tube. Internal weight for additional stability. Black silicone non-scuffing glides.	<i>Square tables, Disks, wrapped edge (DE)</i> 	<i>Round tables, Disks, wrapped edge (DE)</i> 	<i>Round tables, Metallic Trespa top, phenolic black edge (LM)</i> 
<i>Outdoor use:</i> With proper preventative maintenance, the Toledo Table is appropriate for outdoor environments.	<i>Square tables, Metallic Trespa top, phenolic black edge (LM)</i> 		

Jorge Pensi
Pensi Tables
Large Bistro Tables

	description	top	w	d	h	weight
<i>Designer(s):</i> Jorge Pensi, 1988	29TR-35 Round bistro table 	Disks, wrapped edge	35 7/8"		29 1/2"	50 lbs.
		Metallic Trespa, natural black edge	35 7/8"		29 1/2"	46 lbs.
<i>Award(s):</i> First Place, Sidi Selection, Valencia, Spain, 1988; "Delta Plate" of ADI FAD, 1988; Design Center Stuttgart Award, W. Germany, 1990	29TS-35 Square bistro table 	Disks, wrapped edge	35 7/8"	35 7/8"	29 1/2"	58 lbs.
		Metallic Trespa, natural black edge	35 7/8"	35 7/8"	29 1/2"	54 lbs.
	29TR-43 Round dining table 	Disks, wrapped edge	43 1/4"		29 1/2"	65 lbs.
		Metallic Trespa, natural black edge	43 1/4"		29 1/2"	57 lbs.
						

pattern no.	
29TR-35-DE	\$3,976.
29TR-35-LM	4,746.
<hr/>	
29TS-35-DE 	3,976.
29TS-35-LM	4,746.
<hr/>	
29TR-43-DE	4,861.
29TR-43-LM	8,268.

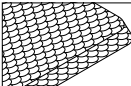
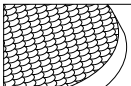
Order Code	Ordering Information	Construction
<i>Example:</i> 29TS-35-DE	<i>Table top finishes:</i>  Disks, wrapped edge * (suffix DE) Metallic Trespa (suffix LM)	 <i>KnollStudio 20-Day Program:</i> The Pensi bistro table is available on the KnollStudio 20-Day program in square 35" size with disks finish and 39" size with disks finish. For specific information, please consult pages 30-33.
29TS Pensi table		<i>Top:</i> Two stainless steel finishes: acid-etched pattern of concentric circles; sanded pattern of scalloped, compact disk-like, 1 1/4" wide circles; both with wrapped edge. One metallic Trespa option with a natural black phenolic edge. The Trespa metallic (LM) top finish is UV resistant, does not reflect heat, easy to clean and made of recyclable materials. The Trespa metallic (LM) top finish is ideal for outdoor use.
35 35" wide and deep	*Disks pattern does not appear on edge.	<i>Maintenance:</i> See pages 28-29.
DE Disks, wrapped edge		<i>Note:</i> The Pensi Table is Greenguard certified.
<i>Note:</i> Pensi Tables are part of a collection. Please refer to Toledo chairs on page 204.	<i>Note:</i> The Pensi Tables are available in the United States only.	
<i>Specify:</i> 1. Pattern number 2. Table size 3. Top finish selection		

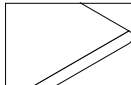
<i>Base:</i> Anodized and polished cast aluminum with 4 7/8" pad-like feet. Four-star base on cafe tables. Five-star base on bistro and dining tables. The central column is a polished and anodized aluminum round tube. Internal weight for additional stability. Black silicone non-scuffing glides.	<i>Base:</i> Anodized and polished cast aluminum with 4 7/8" pad-like feet. Four-star base on cafe tables. Five-star base on bistro and dining tables. The central column is a polished and anodized aluminum round tube. Internal weight for additional stability. Black silicone non-scuffing glides.	<i>Base:</i> Anodized and polished cast aluminum with 4 7/8" pad-like feet. Four-star base on cafe tables. Five-star base on bistro and dining tables. The central column is a polished and anodized aluminum round tube. Internal weight for additional stability. Black silicone non-scuffing glides.
Square tables, Disks, wrapped edge (DE) 	Round tables, Disks, wrapped edge (DE) 	Round tables, Metallic Trespa top, phenolic black edge (LM) 
	Square tables, Metallic Trespa top, phenolic black edge (LM) 	
<i>Outdoor use:</i> With proper preventative maintenance, the Toledo Table is appropriate for outdoor environments.		

Piironen
Arena Cafe Tables

Designer(s):
Piironen, 2003

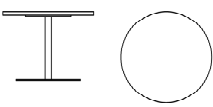
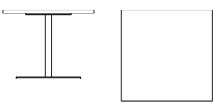
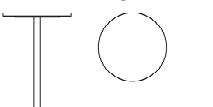
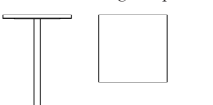

description	w	d	h	weight
23TR Round Cafe Table 	24"	24"	28 1/4"	44 lbs.
	27"	27"	28 1/4"	47 lbs.
	36"	36"	28 1/4"	73 lbs.
	42"	42"	28 1/4"	81 lbs.
23TS Square Cafe Table 	24"	24"	28 1/4"	63 lbs.
	30"	30"	28 1/4"	70 lbs.
23TRH Bar-height Round Cafe Table 	24"	24"	41 1/2"	46 lbs.
	27"	27"	41 1/2"	49 lbs.
23TSH Bar-height Square Cafe Table 	24"	24"	41 1/2"	65 lbs.
	27"	27"	41 1/2"	69 lbs.

pattern no.	silver grey base	chrome base
23TR24- (-)(-)	\$2,265.	\$2,354.
23TR27- (-)(-)	2,464.	2,545.
23TR36- (-)(-)	2,924.	3,008.
23TR42- (-)(-)	3,195.	3,281.
<hr/>		
23TS24- (-)(-)	2,265.	2,354.
23TS30- (-)(-)	2,391.	2,470.
<hr/>		
23TRH24- (-)(-)	2,265.	2,354.
23TRH27- (-)(-)	2,464.	2,545.
<hr/>		
23TSH24- (-)(-)	2,265.	2,354.
23TSH27- (-)(-)	2,464.	2,545.



Order Code

Example: **23TR24-C-W**
23TR24 Arena cafe table, 24"
C Chrome
W White

Specify:

1. Pattern number
2. Column finish selection
3. Top finish

Ordering Information

Column Finish:
 Chrome (C)
 Silver grey paint (S)

Top finish:
 White (W)

 **KnollStudio 20-Day Program:**
 The Arena table is available on the 20-day program in round 36" dining height with chrome base and white finish. Please consult pages 30-33.

Note:
 The Arena Cafe Table is Greenguard certified.

Construction

Top:
 Top is laminate with a natural birch edge. Top is .8" thick. Top is connected to base via mounting plate.



Base:
 Base and mounting plates are solid steel. Laser cut and always finished in a silver grey powder coat finish. The column is bolted to both the base plate and mounting plate. The 24" and 27" round tables comprise a 19.7" round base plate. All other size tables, round and square comprise a 25.5" round baseplate. Column is 2.36" in diameter.

Warren Platner





Dining and Side Tables

Designer(s):
Warren Platner, 1962



description	base w	w	h	weight	top	
3716T Dining table 	20 3/4"	53 3/4"	27"	152 lbs.	Clear glass	
	20 3/4"	53 3/4"	27"	152 lbs.	Bronze glass	
	20 3/4"	53 3/4"	27"	254 lbs.	Natural marble	
	20 3/4"	53 3/4"	27"	254 lbs.	Coated marble	
	20 3/4"	53 3/4"	27"	254 lbs.	Coated marble	
	20 3/4"	53 3/4"	27"	267 lbs.	Granite	
	20 3/4"	53 3/4"	27"	227 lbs.	Veneer	
	20 3/4"	53 3/4"	27"	227 lbs.	Pearwood	
	20 3/4"	53 3/4"	27"	254 lbs.	Coated marble	
	20 3/4"	53 3/4"	27"	254 lbs.	Natural marble	
	3710T Side table 	13"	15 3/4"	18"	14 lbs.	Clear glass
		13"	15 3/4"	18"	14 lbs.	Bronze glass
13"		15 3/4"	18"	22 lbs.	Natural marble	
13"		15 3/4"	18"	22 lbs.	Coated marble	
13"		15 3/4"	18"	22 lbs.	Coated marble	
13"		15 3/4"	18"	22 lbs.	Coated marble	
13"		15 3/4"	18"	22 lbs.	Coated marble	
13"		15 3/4"	18"	15 lbs.	Veneer	
13"		15 3/4"	18"	15 lbs.	Pearwood	
13"		15 3/4"	18"	25 lbs.	Granite	
13"		15 3/4"	18"	22 lbs.	Natural marble	

pattern no.	polished nickel	metallic bronze	gold plated
3716T-()-G2	\$5,796.	\$6,143.	\$9,003.
3716T-()-BRG	6,085.	6,450.	9,455.
3716T-()-(NGC)	8,505.	9,851.	13,212.
3716T-()-(GC, GCS, GB, GBS)	9,536.	10,884.	14,814.
3716T-()-(MN, MNS, MA, MAS, GG, GGS)	10,307.	10,925.	16,011.
3716T-()-(MC, MCS)	10,736.	11,382.	16,676.
3716T-()-(GA)	11,477.	12,826.	17,830.
3716T-()-(LO, LWA, D, V314)	12,253.	12,989.	19,035.
3716T-()-(P)	13,262.	14,057.	20,601.
3716T-()-(MV, MVS)	13,824.	14,650.	21,473.
3716T-()-(NC)	14,918.	15,813.	23,172.
3710T-()-G2	1,349.	1,802.	2,357.
3710T-()-BRG	1,414.	1,893.	2,472.
3710T-()-(NGC)	1,829.	2,314.	2,842.
3710T-()-(GC, GCS, GB, GBS)	1,975.	2,461.	3,068.
3710T-()-(MN, MNS, MA, MAS, GG, GGS)	2,212.	2,346.	3,436.
3710T-()-(MV, MVS)	2,241.	2,376.	3,482.
3710T-()-(MC, MCS)	2,322.	2,464.	3,608.
3710T-()-(LO, LWA, D, V314)	3,078.	3,261.	4,782.
3710T-()-(P)	3,309.	3,506.	5,140.
3710T-()-(GA)	3,748.	4,234.	5,822.
3710T-()-(NC)	4,192.	4,676.	6,512.



Order Code	Ordering Information
<i>Example:</i> 3710T-N-BRG	<i>Frame:</i>
3710T Platner side table	 Polished Nickel (suffix N)
N Nickel	 Metallic Bronze (suffix BRM)
BRG Bronze Glass	18k Gold Plated (suffix GLD)
	<i>Glass top finishes:</i>
	 Clear Glass (suffix G2)
	 Bronze Glass (suffix BRG)
	<i>Veneer finishes:</i>
	Ebonized Walnut (suffix D)
	Light Oak (suffix LO)
	Light Walnut (suffix LWA)
	Reff Dark Cherry (suffix V314)
	<i>Pearwood finish:</i>
	Pearwood (suffix P)
	<i>Polished Coated marble top finishes:</i>
	Arabescatto: white-grey (suffix MA)
	Carrara: white-grey (suffix GC)
	Calacatta: white-grey/beige (suffix MC)
	Empire Beige: beige (suffix GB)
	Grey Marble: light grey (suffix GG)
	Nero Marquina: black (suffix MN)
	Verde Alpi: green (suffix MV)
	<i>Satin Coated marble top finishes:</i>
	Arabescato: white-grey (suffix MAS)
	Calacatta: white-grey/beige (suffix MCS)
	Carrara: white-grey (suffix GCS)
	Empire Beige: beige (suffix GBS)
	Grey Marble: light grey (suffix GGS)
	Nero Marquina: black (suffix MNS)
	Verde Alpi: green (suffix MVS)
	<i>Natural marble top finishes:</i>
	Calacatta: white-grey/beige (suffix NC)
	Carrara: white-grey (suffix NGC)
	<i>Granite top finish:</i>
	Black Andes: black (suffix GA)

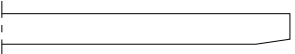
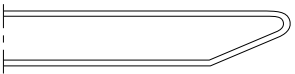

Note:
Platner dining and side tables are part of a collection. Please refer to Platner lounge seating on page 214 and Platner coffee tables on page 358.





- Specify:*
1. Pattern number
 2. Base finish option
 3. Top option

Construction
<i>Maintenance:</i> See pages 28-29.
 <i>KnollStudio 20-Day Program:</i> The Platner side table 3710 in selected finishes are available on the KnollStudio 20-Day program. For specific information, consult pages 30-33.
<i>Note:</i> Marbles with a coating will yellow over time.
The Platner Tables with glass, veneer and natural marble tops are Greenguard certified.
<i>Frame:</i> Vertical steel wire rods welded to circular horizontal and edge-framing rods. Finish in bright nickel with a clear lacquer protection, a painted metallic bronze, or plated in 18k gold.
<i>Base:</i> Clear plastic extrusion ring for smooth bottom surface.
<i>Glass top:</i> 3/8" thick tempered glass for coffee and dining tables. 1/4" thick tempered glass for side tables.
<i>Edge detail for glass:</i> 
<i>Marble Top:</i> All marble tops feature a bevel edge. 3/4" thick coated marble tops have transparent polyester coating to help eliminate use-associated stains. 3/4" thick natural marble tops and granite tops have protective sealer. Larger tops have subtop that fits into base opening to ensure stability.
<i>Marble edge detail:</i> 
<i>Wood Top:</i> Tops are constructed of veneered medium density fiberboard with a cathedral grain pattern in various toned or stained finishes for light oak, light walnut, reff dark cherry and pearwood. Ebonized walnut features a black stain on walnut substrate. All tops are 1 1/16" thick. Edges are 3/4" solid wood to match face veneer. Wood tops are weighted with plates to ensure stability.

Warren Platner Coffee Tables

	description	base w	w	h	weight	top	
Designer(s): Warren Platner, 1962 	3712T Coffee table	18 1/2"	36"	15 1/4"	58 lbs.	Clear glass	
		18 1/2"	36"	15 1/4"	58 lbs.	Bronze glass	
		18 1/2"	36"	15 1/4"	107 lbs.	Natural marble	
		18 1/2"	36"	15 1/4"	107 lbs.	Coated marble	
		18 1/2"	36"	15 1/4"	107 lbs.	Coated marble	
		18 1/2"	36"	15 1/4"	107 lbs.	Coated marble	
		18 1/2"	36"	15 1/4"	107 lbs.	Granite	
		18 1/2"	36"	15 1/4"	107 lbs.	Coated marble	
		18 1/2"	36"	15 1/4"	107 lbs.	Natural marble	
		18 1/2"	36"	15 1/4"	96 lbs.	Natural veneer	
		18 1/2"	36"	15 1/4"	96 lbs.	Pearwood	
		3714T Coffee table 	18 1/2"	42 1/4"	15 1/4"	71 lbs.	Clear glass
			18 1/2"	42 1/4"	15 1/4"	71 lbs.	Bronze glass
			18 1/2"	42 1/4"	15 1/4"	139 lbs.	Natural marble
			18 1/2"	42 1/4"	15 1/4"	139 lbs.	Coated marble
18 1/2"	42 1/4"		15 1/4"	139 lbs.	Coated marble		
18 1/2"	42 1/4"		15 1/4"	139 lbs.	Coated marble		
18 1/2"	42 1/4"		15 1/4"	139 lbs.	Granite		
18 1/2"	42 1/4"		15 1/4"	139 lbs.	Coated marble		
18 1/2"	42 1/4"		15 1/4"	139 lbs.	Natural marble		
18 1/2"	42 1/4"		15 1/4"	108 lbs.	Veneer		
18 1/2"	42 1/4"		15 1/4"	108 lbs.	Pearwood		

pattern no.	polished nickel	metallic bronze	gold plated
3712T-()-G2	\$2,469.	\$2,618.	\$3,836.
3712T-()-BRG 	2,592.	2,748.	4,026.
3712T-()-(NGC)	4,083.	4,714.	6,344.
3712T-()-(GC, GCS, GB, GBS)	4,598.	5,230.	7,142.
3712T-()-(MN, MNS, MA, MAS, GG, GGS)	4,798.	5,085.	7,454.
3712T-()-(MC, MCS)	5,037.	5,341.	7,824.
3712T-()-(GA)	5,937.	6,570.	9,224.
3712T-()-(MV, MVS)	6,422.	6,808.	9,975.
3712T-()-(NC)	7,068.	7,701.	10,980.
3712T-()-(LO, LWA, D, V314)	7,460.	7,907.	11,589.
3712T-()-(P)	8,017.	8,496.	12,454.
3714T-()-G2	3,236.	3,431.	5,027.
3714T-()-BRG 	3,398.	3,604.	5,279.
3714T-()-(NGC)	4,969.	5,602.	7,719.
3714T-()-(GC, GCS, GB, GBS)	5,633.	6,262.	8,750.
3714T-()-(MN, MNS, MA, MAS, GG, GGS)	5,830.	6,179.	9,056.
3714T-()-(MC, MCS)	6,705.	7,108.	10,416.
3714T-()-(GA)	7,292.	7,856.	11,329.
3714T-()-(MV, MVS)	8,267.	8,761.	12,841.
3714T-()-(NC)	8,784.	9,416.	13,645.
3714T-()-(LO, LWA, D, V314)	9,760.	10,346.	15,163.
3714T-()-(P)	10,453.	11,078.	16,238.

Order Code	Ordering Information
<i>Example:</i> 3712T-BRM-MA	<i>Frame:</i>
3712T Platner coffee table	 Polished Nickel (suffix N)
BRM Metallic Bronze	 Metallic Bronze (suffix BRM)
MA Arabescato Marble	18k Gold Plated (suffix GLD)
	<i>Glass top finishes:</i>
	 Clear Glass (suffix G2)
	 Bronze Glass (suffix BRG)
	<i>Veneer finishes:</i>
	Ebonized Walnut (suffix D)
	Light Oak (suffix LO)
	Light Walnut (suffix LWA)
	Reff Dark Cherry (suffix V314)
	<i>Pearwood finish:</i>
	Pearwood (suffix P)
	<i>Polished Coated marble top finishes:</i>
	Arabescato: white-grey (suffix MA)
	Carrara: white-grey (suffix GC)
	Calacatta: white-grey/beige (suffix MC)
	Empire Beige: beige (suffix GB)
	Grey Marble: light grey (suffix GG)
	Nero Marquina: black (suffix MN)
	Verde Alpi: green (suffix MV)
	<i>Natural marble top finishes:</i>
	Calacatta: white-grey/beige (suffix NC)
	Carrara: white-grey (suffix NGC)
	<i>Granite top finish:</i>
	Black Andes: black (suffix GA)
	<i>Satin Coated marble top finishes:</i>
	Arabescato: white-grey (suffix MAS)
	Calacatta: white-grey/beige (suffix MCS)
	Carrara: white-grey (suffix GCS)
	Empire Beige: beige (suffix GBS)
	Grey Marble: light grey (suffix GGS)
	Nero Marquina: black (suffix MNS)
	Verde Alpi: green (suffix MVS)

Note:
Platner coffee table are part of a collection. Please refer to Platner lounge seating on page 214 and Platner dining and side tables on page 356.

- Specify:*
1. Pattern number
 2. Base finish option
 3. Top option

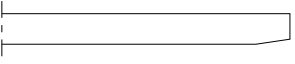
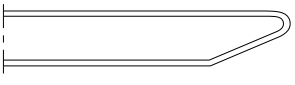
Construction
<i>Maintenance:</i> See pages 28-29.
 <i>KnollStudio 20-Day Program:</i> The Platner coffee table 3712 and 3714 in selected finishes are available on the KnollStudio 20-Day program. For specific information, consult pages 30-33.
<i>Note:</i> Marbles with a coating will yellow over time.
The Platner Tables with glass, veneer and natural marble tops are Greenguard certified.
<i>Frame:</i> Vertical steel wire rods welded to circular horizontal and edge-framing rods. Finish in bright nickel with a clear lacquer protection, a painted metallic bronze, or plated in 18k gold.
<i>Base:</i> Clear plastic extrusion ring for smooth bottom surface.
<i>Glass top:</i> 3/8" thick tempered glass for coffee and dining tables. 1/4" thick tempered glass for side tables.
<i>Edge detail for glass:</i> 
<i>Marble Top:</i> All marble tops feature a bevel edge. 3/4" thick coated marble tops have transparent polyester coating to help eliminate use-associated stains. 3/4" thick natural marble tops and granite tops have protective sealer. Larger tops have subtop that fits into base opening to ensure stability.
<i>Marble edge detail:</i> 
<i>Wood Top:</i> Tops are constructed of veneered medium density fiberboard with a cathedral grain pattern in various toned or stained finishes for light oak, light walnut, reff dark cherry and pearwood. Ebonized walnut features a black stain on walnut substrate. All tops are 1 1/16" thick. Edges are 1/4" solid wood to match face veneer. Wood tops are weighted with plates to ensure stability.

Jens Risom

Dining and Side Tables

Designer(s):
Jens Risom, 1943



description	w	d	h	weight	base	top
642TR Round dining table 	42"	42"	23"	40 lbs.	Clear Maple	Clear Maple
	42"	42"	23"	40 lbs.	Ebonized Maple	Ebonized Walnut
	42"	42"	23"	40 lbs.	Light Walnut	Light Walnut
614TS Square side table 	14"	14"	18"	7 lbs.	Clear Maple	Clear Maple
	14"	14"	18"	7 lbs.	Ebonized Maple	Ebonized Walnut
	14"	14"	18"	7 lbs.	Light Walnut	Light Walnut
	14"	14"	18"	8 lbs.	Teak	Teak
618TR Round side table 	18"	18"	20"	9 lbs.	Clear Maple	Clear Maple
	18"	18"	20"	9 lbs.	Ebonized Maple	Ebonized Walnut
	18"	18"	20"	9 lbs.	Light Walnut	Light Walnut
	18"	18"	20"	10 lbs.	Teak	Teak
643TA Amoeba shaped coffee table 	42"	32"	16"	22 lbs.	Clear Maple	Clear Maple
	42"	32"	16"	22 lbs.	Ebonized Maple	Ebonized Walnut
	42"	32"	16"	22 lbs.	Light Walnut	Light Walnut

pattern no.	list
642TR-KC-KC	\$1,938.
642TR-KE-D	2,015.
642TR-LWT-LWT	2,116.
614TS-KC-KC	902.
614TS-KE-D	936.
614TS-LWT-LWT	984.
614TS-K-K	1,168.
618TR-KC-KC	964.
618TR-KE-D	1,002.
618TR-LWT-LWT	1,054.
618TR-K-K	1,269.
643TA-KC-KC	1,655.
643TA-KE-D	1,723.
643TA-LWT-LWT	1,809.

Order Code

<i>Example:</i>	642TR-KE-BL
642TR	Round dining table
KE	Ebonized Maple
D	Ebonized Walnut

Note:
The Risom Tables are part of a Collection. Please refer to Risom chairs on page 234 and lounge chairs on page 108.

Specify:

1. Pattern number
2. Base finish selection
3. Top finish selection

Ordering Information

Base finishes:
Clear Maple (suffix KC)
Ebonized Maple (suffix KE)
Light Walnut (suffix LWT)
Teak (suffix K)

Top finishes:
Clear Maple (suffix KC)
Ebonized Walnut (suffix D)
Light Walnut (suffix LWT)
Teak (suffix K)

Shipping information:
Dining table and Amoeba table shipped knocked down with top and legs in one box. Simple field assembly required. Side tables and coffee tables shipped fully assembled.

Maintenance:
See pages 28-29.

Note:
The Risom dining, side and amoeba tables are Greenguard certified.



Construction

Legs and aprons:
Solid maple or walnut hardwood. Mortise and tenon joints.

Top:
Tops are veneer with cathedral pattern with poplar cross bands and backing. Core and edge is solid hardwood lumber in clear finish.

Finish:
Clear lacquer or ebonized finish.

Jens Risom
Child's Amoeba Table

	description	w	d	h	weight	base	top
<p><i>Designer(s):</i> Jens Risom, 1943</p> 	<p>643TAS Child's Amoeba shaped coffee table</p> 	42"	32"	20"	32 lbs.	Honey Beech	Honey laminate

pattern no.	
643TAS-HB-HL	\$757.

Order Code	Ordering Information
<i>Example:</i> 643TAS-HB-HL	<i>Base finish:</i> Honey Beech (suffix HB)
643TAS	Child's Risom Amoeba table
HB	Honey Beech
HL	Honey laminate

Top finish:
Honey laminate (suffix HL)

Construction

Shipping information:
Child's Risom Amoeba table is shipped knocked down with top and legs in one box. Simple field assembly required.

Maintenance:
See pages 28-29.

Note:
The Child's Risom Amoeba table is compliant to the Consumer Product Safety Improvement Act of 2008 for Children's Products, 16 C.F.R. 1303, CPSIA Title 1 Section 101 for Total Lead in Substrates and Surface Coatings.

Legs and aprons:
Select European Beech hardwood with a toned natural finish. Mortise and tenon construction.

Top:
3/4" thick wood grain laminate top is 3-ply construction with medium density fiberboard core and plastic laminate backer. Honey laminate features a Beech grain pattern.

Finish:
Toned catalyzed lacquer finish.



Note:
The Child's Risom Amoeba table is part of a Collection. Please refer to the Child's Risom side chairs on page 106.

- Specify:*
1. Pattern number
 2. Base finish selection
 3. Top finish selection

Jens Risom
Outdoor Tables

Designer(s):
Jens Risom, 1943



description	w	d	h	weight	base	top
614TS Square side table 	14"	14"	18"	8 lbs.	Teak	Teak
618TR Round side table 	18"	18"	20"	10 lbs.	Teak	Teak

pattern no.	list
614TS-K-K	\$1,168.
618TR-K-K	1,269.

Order Code	Ordering Information	Construction
<i>Example:</i> 618TR-K-K	<i>Base finishes:</i> Teak (suffix K)	<i>Shipping information:</i> Side tables are shipped fully assembled.
618TR Round side table	<i>Top finishes:</i> Teak (suffix K)	<i>Legs and aprons:</i> Solid teak lumber with oiled finish. Mortise and tenon joints.
K Teak		<i>Top:</i> Solid teak lumber with oiled finish.
K Teak		<i>Note:</i> Teak will patina over time if left outdoors and will turn a silvery grey color.
	<i>Note:</i> The Risom side tables are Greenguard certified.	<i>Maintenance:</i> Teak oil can be applied with a paint brush every three months to maintain rich color.

Note:
The Outdoor Risom Tables are part of a Collection. Please refer to Outdoor Risom Seating on page 240 .

Specify:

1. Pattern number
2. Base finish selection
3. Top finish selection

Eero Saarinen Round Dining Tables

Designer(s):
Eero Saarinen, 1957

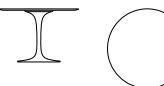

description	w	d	h	weight	top
172TR Small round table, dining height 	35 1/4"		28 1/4"	47 lbs.	Laminate
	35 1/4"		28 1/4"	95 lbs.	Natural marble
	35 1/4"		28 1/4"	95 lbs.	Coated marble
	35 1/4"		28 1/4"	95 lbs.	Coated marble
	35 1/4"		28 1/4"	95 lbs.	Vetro Bianco
	35 1/4"		28 1/4"	95 lbs.	Coated marble
	35 1/4"		28 1/4"	95 lbs.	Coated marble
	35 1/4"		28 1/4"	95 lbs.	Coated marble
	35 1/4"		28 1/4"	51 lbs.	Veneer
	35 1/4"		28 1/4"	51 lbs.	Veneer
	35 1/4"		28 1/4"	51 lbs.	Pearwood
	35 1/4"		28 1/4"	103 lbs.	Granite
	35 1/4"		28 1/4"	95 lbs.	Natural marble
	35 1/4"		28 1/4"	95 lbs.	Coated marble
	35 1/4"		28 1/4"	95 lbs.	Slate, natural
173TR Medium round table, dining height 	42 1/4"		28 1/4"	58 lbs.	Laminate
	42 1/4"		28 1/4"	125 lbs.	Natural marble
	42 1/4"		28 1/4"	125 lbs.	Coated marble
	42 1/4"		28 1/4"	125 lbs.	Vetro Bianco
	42 1/4"		28 1/4"	125 lbs.	Coated marble
	42 1/4"		28 1/4"	125 lbs.	Coated marble
	42 1/4"		28 1/4"	125 lbs.	Coated marble
	42 1/4"		28 1/4"	63 lbs.	Veneer
	42 1/4"		28 1/4"	125 lbs.	Coated marble
	42 1/4"		28 1/4"	63 lbs.	Veneer
	42 1/4"		28 1/4"	125 lbs.	Coated marble
	42 1/4"		28 1/4"	63 lbs.	Pearwood
	42 1/4"		28 1/4"	136 lbs.	Granite
	42 1/4"		28 1/4"	125 lbs.	Coated marble
	42 1/4"		28 1/4"	125 lbs.	Slate, natural
42 1/4"		28 1/4"	125 lbs.	Natural marble	

pattern no.	
172TR-(F2)-(1, 2, PL)	\$3,140.
172TR-(NGC)-(1, 2, PL)	3,943.
172TR-(MG, MGS)-(1, 2, PL)	4,269.
172TR-(GC, GCS, GB, GBS)-(1, 2, PL)	4,461.
172TR-(VB)-(1, 2, PL)	4,567.
172TR-(MN, MNS, MA, MAS, GG, GGS)-(1, 2, PL)	4,793.
172TR-(ME, MES)-(1, 2, PL)	5,097.
172TR-(MC, MCS)-(1, 2, PL)	5,251.
172TR-(LO, LWA, D, V314)-(1, 2, PL)	5,311.
172TR-(RO, TK)-(1, 2, PL)	5,405.
172TR-(P)-(1, 2, PL)	5,750.
172TR-(GA)-(1, 2, PL)	5,888.
172TR-(NC)-(1, 2, PL)	7,022.
172TR-(MV, MVS)-(1, 2, PL)	7,029.
172TR-(SN)-(1, 2, PL)	7,341.
173TR-(F2)-(1, 2, PL)	3,350.
173TR-(NGC)-(1, 2, PL)	4,830.
173TR-(MG, MGS)-(1, 2, PL)	5,392.
173TR-(VB)-(1, 2, PL)	5,420.
173TR-(GC, GCS, GB, GBS)-(1, 2, PL)	5,492.
173TR-(MN, MNS, MA, MAS, GG, GGS)-(1, 2, PL)	5,592.
173TR-(RO, TK)-(1, 2, PL)	5,919.
173TR-(MC, MCS)-(1, 2, PL)	6,128.
173TR-(LO, LWA, D, V314)-(1, 2, PL)	6,388.
173TR-(ME, MES)-(1, 2, PL)	6,475.
173TR-(P)-(1, 2, PL)	6,952.
173TR-(GA)-(1, 2, PL)	7,176.
173TR-(MV, MVS)-(1, 2, PL)	7,533.
173TR-(SN)-(1, 2, PL)	7,850.
173TR-(NC)-(1, 2, PL)	8,737.

Order Code

<i>Example:</i>	176TR-MN-1
176TR	Saarinen dining table
MN	Nero Marquina Marble
1	Black

Note:
Saarinen tables are part of a collection. Please refer to Saarinen side chairs, lounge seating, and executive chairs on beginning on page 242.

Specify:

1. Pattern number
2. Top selection
3. Base finish selection

Ordering Information

Base finishes:

Black (suffix 1)
Platinum (suffix PL)
☑ White (suffix 2)

Laminate top finish:

☑ White (suffix F2)

Veneer finishes:

Ebonized Walnut (suffix D)
Light Oak (suffix LO)
Light Walnut (suffix LWA)
Pearwood (suffix P)
Reff Dark Cherry (suffix V314)
Rosewood (suffix RO)
Teak (suffix TK)

Polished Coated marble top finishes:

Arabescato: white-grey (suffix MA)
Calacatta: white-grey/beige (suffix MC)
Carrara: white-grey (suffix GC)
Empire Beige: beige (suffix GB)
Espresso: dark brown (suffix ME)
Grey Marble: light grey (suffix GG)
Grigio Marquina: warm grey (suffix MG)
Nero Marquina: black (suffix MN)
Verde Alpi: green (suffix MV) *

Satin Coated marble top finishes:

Arabescato: white-grey (suffix MAS)
Calacatta: white-grey/beige (suffix MCS)
Carrara: white-grey (suffix GCS)
Empire Beige: beige (suffix GBS)
Espresso: dark brown (suffix MES)
Grey Marble: light grey (suffix GGS)
Grigio Marquina: warm grey (suffix MGS)
Nero Marquina: black (suffix MNS)
Verde Alpi: green (suffix MVS) *

Natural marble top finishes:

Calacatta: white-grey/beige (suffix NC)
Carrara: white-grey (suffix NGC)

Granite top finish:

Black Andes: black (suffix GA)

Engineered Stone:

Vetro Bianco: white (suffix VB)

Slate top finish:

Slate, natural (suffix SN)

* Note:

Verdi Alpi may not be specified for 165TR.

Construction

☑ KnollStudio 20-Day Program:

Saarinen dining table 164TR, 173TR, 176TR is available on the KnollStudio 20-Day program with a white base and white laminate top. For specific information, consult pages 30-33.

Maintenance:

See pages 28-29.

Note:

Top and base shipped in separate packages. The Knoll logo is stamped into the base of the Saarinen tables. Tops have nameplate with designer's signature. **Not suitable for outdoor use.**

Marbles with a coating will yellow over time.

Saarinen Dining Tables with Laminate, Natural Marble, Veneer or Granite tops are Greenguard certified.

Base:

Heavy molded cast aluminum, strap-polished. Black and white bases are coated in a tough, abrasion-resistant Rilsan finish. Platinum bases consist of a highly resilient polyurethane enamel wet coat with a clear satin finish.

Base Measurements:

172TR, 173TR, 176TR: 20" diameter
164TR, 165TR: 25.984" diameter

Marble and Laminate Tops:

Bevel-edged satin smooth laminate or marble. 1/4" thick coated marble tops have transparent polyester coating to help eliminate use-associated stains. 3/4" thick natural marble tops and granite tops have protective sealer. Laminate tops are 1.06" thick.

Laminate edge detail:

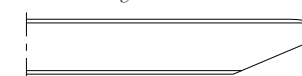

Marble edge detail:

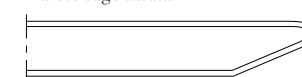

Wood Top:

Tops are constructed of veneered medium density fiberboard with a cathedral grain pattern in various clear or toned stains. All tops are 1 1/16" thick with the exception of 164TR and 165TR which are 1 1/4" thick. Edges are 1/4" solid wood to match face veneer.

Engineered Stone:

Polished, bright white surface is nonporous and more compact than most granites. Comprised of 93% fused quartz. It does not yellow or stain and is scratch resistant. Suitable for outdoors.

Slate:

Beveled edge, 3/4" thick natural cleft slate.

Note:



Vetro Bianco (VBO) top for outdoor use is only available on 162TR, 164TR, 169TR, 172TR, 173TR, 174TO tables. 162TR, 164TR, 172TR, 173TR, and 174TO use a phenolic subtop with exposed black edges and white laminate faces. Stainless steel hardware will be used for all connections.

Eero Saarinen Round Dining Tables

Designer(s):
Eero Saarinen, 1957

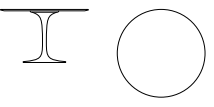
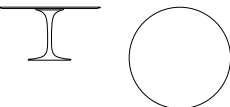

description	w	d	h	weight	top
176TR Medium round table, dining height 	47 1/4"		28 3/4"	76 lbs.	Laminate
	47 1/4"		28 3/4"	153 lbs.	Natural marble
	47 1/4"		28 3/4"	153 lbs.	Coated marble
	47 1/4"		28 3/4"	153 lbs.	Coated marble
	47 1/4"		28 3/4"	153 lbs.	Vetro Bianco
	47 1/4"		28 3/4"	153 lbs.	Coated marble
	47 1/4"		28 3/4"	74 lbs.	Veneer
	47 1/4"		28 3/4"	153 lbs.	Coated marble
	47 1/4"		28 3/4"	74 lbs.	Veneer
	47 1/4"		28 3/4"	153 lbs.	Coated marble
	47 1/4"		28 3/4"	74 lbs.	Pearwood
	47 1/4"		28 3/4"	153 lbs.	Coated marble
	47 1/4"		28 3/4"	153 lbs.	Slate, natural
	47 1/4"		28 3/4"	166 lbs.	Granite
	47 1/4"		28 3/4"	153 lbs.	Natural marble
164TR Large round table, dining height 	54"		28 3/4"	102 lbs.	Laminate
	54"		28 3/4"	203 lbs.	Natural marble
	54"		28 3/4"	203 lbs.	Vetro Bianco
	54"		28 3/4"	203 lbs.	Coated marble
	54"		28 3/4"	203 lbs.	Coated marble
	54"		28 3/4"	203 lbs.	Coated marble
	54"		28 3/4"	103 lbs.	Veneer
	54"		28 3/4"	203 lbs.	Coated marble
	54"		28 3/4"	103 lbs.	Veneer
	54"		28 3/4"	203 lbs.	Coated marble
	54"		28 3/4"	103 lbs.	Pearwood
	54"		28 3/4"	218 lbs.	Granite
	54"		28 3/4"	203 lbs.	Coated marble
	54"		28 3/4"	203 lbs.	Natural marble

pattern no.	
176TR-(F2)-(1, 2, PL) 	\$3,596.
176TR-(NGC)-(1, 2, PL)	5,136.
176TR-(GC, GCS, GB, GBS)-(1, 2, PL)	5,899.
176TR-(MN, MNS, MA, MAS, GG, GGS)-(1, 2, PL)	6,005.
176TR-(VB)-(1, 2, PL)	6,189.
176TR-(MG, MGS)-(1, 2, PL)	6,237.
176TR-(RO, TK)-(1, 2, PL)	6,276.
176TR-(MC, MCS)-(1, 2, PL)	6,581.
176TR-(LO, LWA, D, V314)-(1,2, PL)	7,149.
176TR-(ME, MES)-(1, 2, PL)	7,607.
176TR-(P)-(1, 2, PL)	7,807.
176TR-(MV, MVS)-(1, 2, PL)	8,033.
176TR-(SN)-(1, 2, PL)	8,106.
176TR-(GA)-(1,2, PL)	8,206.
176TR-(NC)-(1, 2, PL)	10,275.
164TR-F2-(1,2, PL) 	4,787.
164TR-(NGC)-(1, 2, PL)	6,872.
164TR-VB-(1, 2, PL)	7,804.
164TR-(GC, GCS, GB, GBS)-(1, 2, PL)	7,906.
164TR-(MN, MNS, MA, MAS, GG, GGS)-(1, 2, PL)	8,074.
164TR-(MG, MGS)-(1, 2, PL)	8,207.
164TR-(RO, TK)-(1, 2, PL)	8,761.
164TR-(MC, MCS)-(1, 2, PL)	8,849.
164TR-(LO, LWA, D, V314)-(1, 2, PL)	8,954.
164TR-(ME, MES)-(1, 2, PL)	9,736.
164TR-(P)-(1, 2, PL)	9,744.
164TR-(GA)-(1, 2, PL)	9,939.
164TR-(MV, MVS)-(1, 2, PL)	10,850.
164TR-(NC)-(1, 2, PL)	13,313.

Order Code

<i>Example:</i>	176TR-MN-1
176TR	Saarinen dining table
MN	Nero Marquina Marble
1	Black

Note:
Saarinen tables are part of a collection. Please refer to Saarinen side chairs, lounge seating, and executive chairs on beginning on page 242.

Specify:

1. Pattern number
2. Top selection
3. Base finish selection

Ordering Information

Base finishes:

Black (suffix 1)
Platinum (suffix PL)
 White (suffix 2)

Laminate top finish:

 White (suffix F2)

Veneer finishes:

Ebonized Walnut (suffix D)
Light Oak (suffix LO)
Light Walnut (suffix LWA)
Pearwood (suffix P)
Reff Dark Cherry (suffix V314)
Rosewood (suffix RO)
Teak (suffix TK)

Polished Coated marble top finishes:

Arabescato: white-grey (suffix MA)
Calacatta: white-grey/beige (suffix MC)
Carrara: white-grey (suffix GC)
Empire Beige: beige (suffix GB)
Espresso: dark brown (suffix ME)
Grey Marble: light grey (suffix GG)
Grigio Marquina: warm grey (suffix MG)
Nero Marquina: black (suffix MN)
Verde Alpi: green (suffix MV) *

Satin Coated marble top finishes:

Arabescato: white-grey (suffix MAS)
Calacatta: white-grey/beige (suffix MCS)
Carrara: white-grey (suffix GCS)
Empire Beige: beige (suffix GBS)
Espresso: dark brown (suffix MES)
Grey Marble: light grey (suffix GGS)
Grigio Marquina: warm grey (suffix MGS)
Nero Marquina: black (suffix MNS)
Verde Alpi: green (suffix MVS) *

Natural marble top finishes:

Calacatta: white-grey/beige (suffix NC)
Carrara: white-grey (suffix NGC)

Granite top finish:

Black Andes: black (suffix GA)

Engineered Stone:

Vetro Bianco: white (suffix VB)

Slate top finish:

Slate, natural (suffix SN)

* Note:

Verdi Alpi may not be specified for 165TR.

Construction

KnollStudio 20-Day Program:

Saarinen dining table 164TR, 173TR, 176TR is available on the KnollStudio 20-Day program with a white base and white laminate top. For specific information, consult pages 30-33.

Maintenance:

See pages 28-29.

Note:

Top and base shipped in separate packages. The Knoll logo is stamped into the base of the Saarinen tables. Tops have nameplate with designer's signature. **Not suitable for outdoor use.**

Marbles with a coating will yellow over time.

Saarinen Dining Tables with Laminate, Natural Marble, Veneer or Granite tops are Greenguard certified.

Base:

Heavy molded cast aluminum, strap-polished. Black and white bases are coated in a tough, abrasion-resistant Rilsan finish. Platinum bases consist of a highly resilient polyurethane enamel wet coat with a clear satin finish.

Base Measurements:

172TR, 173TR, 176TR: 20" diameter
164TR, 165TR: 25.984" diameter

Marble and Laminate Tops:

Bevel-edged satin smooth laminate or marble. 3/4" thick coated marble tops have transparent polyester coating to help eliminate use-associated stains. 3/4" thick natural marble tops and granite tops have protective sealer. Laminate tops are 1.06" thick.

Laminate edge detail:

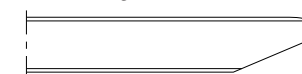

Marble edge detail:

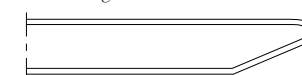

Wood Top:

Tops are constructed of veneered medium density fiberboard with a cathedral grain pattern in various clear or toned stains. All tops are 1 1/16" thick with the exception of 164TR and 165TR which are 1 1/4" thick. Edges are 1/4" solid wood to match face veneer.

Engineered Stone:

Polished, bright white surface is nonporous and more compact than most granites. Comprised of 93% fused quartz. It does not yellow or stain and is scratch resistant. Suitable for outdoors.

Slate:

Beveled edge, 3/4" thick natural cleft slate.

Note:

Vetro Bianco (VBO) top for outdoor use is only available on 162TR, 164TR, 169TR, 172TR, 173TR, 174TO tables. 162TR, 164TR, 172TR, 173TR, and 174TO use a phenolic subtop with exposed black edges and white laminate faces. Stainless steel hardware will be used for all connections.

Eero Saarinen Round Dining Tables

	description	w	d	h	weight	top
<p><i>Designer(s):</i> Eero Saarinen, 1957</p>	165TR Large round table, dining height	60"		28 3/4"	115 lbs.	Laminate
		60"		28 3/4"	244 lbs.	Natural marble
		60"		28 3/4"	244 lbs.	Coated marble
		60"		28 3/4"	121 lbs.	Veneer
		60"		28 3/4"	121 lbs.	Veneer
		60"		28 3/4"	244 lbs.	Coated marble
		60"		28 3/4"	244 lbs.	Vetro Bianco
		60"		28 3/4"	121 lbs.	Pearwood
		60"		28 3/4"	244 lbs.	Coated marble
		60"		28 3/4"	263 lbs.	Granite
		60"		28 3/4"	244 lbs.	Coated marble
		60"		28 3/4"	244 lbs.	Coated marble
		60"		28 3/4"	244 lbs.	Natural marble

pattern no.	
165TR-F2-(1, 2, PL)	\$7,474.
165TR-(NGC)-(1, 2, PL)	7,878.
165TR-(GC, GCS, GB, GBS)-(1, 2, PL)	9,152.
165TR-(RO, TK)-(1, 2, PL)	9,328.
165TR-(LO, LWA, D, V314)-(1, 2, PL)	9,735.
165TR-(MG, MGS)-(1, 2, PL)	9,831.
165TR-VB-(1, 2, PL)	10,143.
165TR-(P)-(1, 2, PL)	10,572.
165TR-(ME, MES)-(1, 2, PL)	11,886.
165TR-(GA)-(1, 2, PL)	11,933.
165TR-(MN, MNS, MA, MAS, GG, GGS)-(1, 2, PL)	12,422.
165TR-(MC, MCS)-(1, 2, PL)	13,602.
165TR-(NC)-(1, 2, PL)	15,980.

Order Code	Ordering Information
<i>Example:</i> 176TR-MN-1	<i>Base finishes:</i>
176TR Saarinen dining table	Black (suffix 1)
MN Nero Marquina Marble	Platinum (suffix PL)
1 Black	☑ White (suffix 2)
	<i>Laminate top finish:</i>
	☑ White (suffix F2)
	<i>Veneer finishes:</i>
	Ebonized Walnut (suffix D)
	Light Oak (suffix LO)
	Light Walnut (suffix LWA)
	Pearwood (suffix P)
	Reff Dark Cherry (suffix V314)
	Rosewood (suffix RO)
	Teak (suffix TK)
	<i>Polished Coated marble top finishes:</i>
	Arabescato: white-grey (suffix MA)
	Calacatta: white-grey/beige (suffix MC)
	Carrara: white-grey (suffix GC)
	Empire Beige: beige (suffix GB)
	Espresso: dark brown (suffix ME)
	Grey Marble: light grey (suffix GG)
	Grigio Marquina: warm grey (suffix MG)
	Nero Marquina: black (suffix MN)
	Verde Alpi: green (suffix MV) *
	<i>Satin Coated marble top finishes:</i>
	Arabescato: white-grey (suffix MAS)
	Calacatta: white-grey/beige (suffix MCS)
	Carrara: white-grey (suffix GCS)
	Empire Beige: beige (suffix GBS)
	Espresso: dark brown (suffix MES)
	Grey Marble: light grey (suffix GGS)
	Grigio Marquina: warm grey (suffix MGS)
	Nero Marquina: black (suffix MNS)
	Verde Alpi: green (suffix MVS) *
	<i>Natural marble top finishes:</i>
	Calacatta: white-grey/beige (suffix NC)
	Carrara: white-grey (suffix NGC)
	<i>Granite top finish:</i>
	Black Andes: black (suffix GA)
	<i>Engineered Stone:</i>
	Vetro Bianco: white (suffix VB)
	<i>Slate top finish:</i>
	Slate, natural (suffix SN)
	<i>* Note:</i>
	Verdi Alpi may not be specified for 165TR.



Note:
Saarinen tables are part of a collection. Please refer to Saarinen side chairs, lounge seating, and executive chairs on beginning on page 242.

- Specify:*
1. Pattern number
 2. Top selection
 3. Base finish selection

Construction
☑ <i>KnollStudio 20-Day Program:</i> Saarinen dining table 164TR, 173TR, 176TR is available on the KnollStudio 20-Day program with a white base and white laminate top. For specific information, consult pages 30-33.
<i>Maintenance:</i> See pages 28-29.
<i>Note:</i> Top and base shipped in separate packages. The Knoll logo is stamped into the base of the Saarinen tables. Tops have nameplate with designer's signature. Not suitable for outdoor use.
Marbles with a coating will yellow over time.
Saarinen Dining Tables with Laminate, Natural Marble, Veneer or Granite tops are Greenguard certified.
<i>Base:</i> Heavy molded cast aluminum, strap-polished. Black and white bases are coated in a tough, abrasion-resistant Rilsan finish. Platinum bases consist of a highly resilient polyurethane enamel wet coat with a clear satin finish.
<i>Base Measurements:</i> 172TR, 173TR, 176TR: 20" diameter 164TR, 165TR: 25.984" diameter
<i>Marble and Laminate Tops:</i> Bevel-edged satin smooth laminate or marble. 3/4" thick coated marble tops have transparent polyester coating to help eliminate use-associated stains. 3/4" thick natural marble tops and granite tops have protective sealer. Laminate tops are 1.06" thick.
<i>Wood Top:</i> Tops are constructed of veneered medium density fiberboard with a cathedral grain pattern in various clear or toned stains. All tops are 1 1/16" thick with the exception of 164TR and 165TR which are 1 1/4" thick. Edges are 1/4" solid wood to match face veneer.
<i>Engineered Stone:</i> Polished, bright white surface is nonporous and more compact than most granites. Comprised of 93% fused quartz. It does not yellow or stain and is scratch resistant. Suitable for outdoors.
<i>Slate:</i> Beveled edge, 3/4" thick natural cleft slate.
<i>Note:</i> Vetro Bianco (VBO) top for outdoor use is only available on 162TR, 164TR, 169TR, 172TR, 173TR, 174TO tables. 162TR, 164TR, 172TR, 173TR, and 174TO use a phenolic subtop with exposed black edges and white laminate faces. Stainless steel hardware will be used for all connections.
<i>Laminate edge detail:</i>
<i>Marble edge detail:</i>

Eero Saarinen

Oval Dining Tables

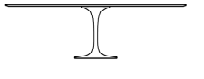
	description	w	d	h	weight	top
<p><i>Designer(s):</i> Eero Saarinen, 1957</p> 	<p>174TO Medium oval table, dining height</p> 	78"	47 1/4"	28 1/4"	131 lbs.	Laminate
		78"	47 1/4"	28 1/4"	259 lbs.	Natural marble
		78"	47 1/4"	28 1/4"	259 lbs.	Coated marble
		78"	47 1/4"	28 1/4"	259 lbs.	Coated marble
		78"	47 1/4"	28 1/4"	131 lbs.	Veneer
		78"	47 1/4"	28 1/4"	259 lbs.	Vetro Bianco
		78"	47 1/4"	28 1/4"	131 lbs.	Veneer
		78"	47 1/4"	28 1/4"	259 lbs.	Coated marble
		78"	47 1/4"	28 1/4"	259 lbs.	Coated marble
		78"	47 1/4"	28 1/4"	229 lbs.	Granite
		78"	47 1/4"	28 1/4"	259 lbs.	Slate, natural
		78"	47 1/4"	28 1/4"	131 lbs.	Pearwood
		78"	47 1/4"	28 1/4"	259 lbs.	Coated marble
		78"	47 1/4"	28 1/4"	259 lbs.	Natural marble
78"	47 1/4"	28 1/4"	259 lbs.	Coated marble		
 <p>175TO Large oval table, dining height</p>	96"	54"	28 1/4"	169 lbs.	Laminate	
	96"	54"	28 1/4"	348 lbs.	Natural marble	
	96"	54"	28 1/4"	168 lbs.	Veneer	
	96"	54"	28 1/4"	348 lbs.	Coated marble	
	96"	54"	28 1/4"	348 lbs.	Coated marble	
	96"	54"	28 1/4"	168 lbs.	Veneer	
	96"	54"	28 1/4"	348 lbs.	Vetro Bianco	
	96"	54"	28 1/4"	348 lbs.	Coated marble	
	96"	54"	28 1/4"	168 lbs.	Pearwood	
	96"	54"	28 1/4"	374 lbs.	Granite	
	96"	54"	28 1/4"	348 lbs.	Coated marble	
	96"	54"	28 1/4"	348 lbs.	Coated marble	
	96"	54"	28 1/4"	348 lbs.	Natural marble	
	96"	54"	28 1/4"	348 lbs.	Coated marble	

pattern no.	
174TO-(F2)-(1, 2, PL)	\$8,244.
174TO-(NGC)-(1, 2, PL)	8,419.
174TO-(GC, GCS, GB, GBS)-(1, 2, PL)	9,862.
174TO-(MG, MGS)-(1, 2, PL)	10,099.
174TO-(RO, TK)-(1, 2, PL)	10,492.
174TO-(VB)-(1, 2, PL)	11,031.
174TO-(LO, LWA, D, V314)-(1, 2, PL)	12,243.
174TO-(ME, MES)-(1, 2, PL)	12,664.
174TO-(MN, MNS, MA, MAS, GG, GGS)-(1, 2, PL)	12,748.
174TO-(GA)-(1, 2, PL)	12,769.
174TO-(SN)-(1, 2, PL)	13,049.
174TO-(P)-(1, 2, PL)	13,323.
174TO-(MC, MCS)-(1, 2, PL)	13,958.
174TO-(NC)-(1, 2, PL)	16,467.
174TO-(MV, MVS)-(1, 2, PL)	18,723.
175TO-F2-(1, 2, PL)	9,331.
175TO-(NGC)-(1, 2, PL)	10,585.
175TO-(RO, TK)-(1, 2, PL)	11,596.
175TO-(GC, GCS, GB, GBS)-(1, 2, PL)	12,592.
175TO-(MG, MGS)-(1, 2, PL)	12,950.
175TO-(LO, LWA, D, V314)-(1, 2, PL)	13,631.
175TO-(VB)-(1, 2, PL)	14,203.
175TO-(MN, MNS, MA, MAS, GG, GGS)-(1, 2, PL)	14,642.
175TO-(P)-(1, 2, PL)	14,880.
175TO-(GA)-(1, 2, PL)	15,425.
175TO-(MC, MCS)-(1, 2, PL)	16,031.
175TO-(ME, MES)-(1, 2, PL)	16,870.
175TO-(NC)-(1, 2, PL)	21,158.
175TO-(MV, MVS)-(1, 2, PL)	21,516.

Order Code	Ordering Information
<i>Example:</i> 174TO-MA-PL	<i>Base finishes:</i>
174TO Saarinen dining table	Black (suffix 1)
MA Arabescato Marble	Platinum (suffix PL)
PL Platinum	White (suffix 2)
	<i>Laminate top finish:</i>
	White (suffix F2)
	<i>Veneer finishes:</i>
	Ebonized Walnut (suffix D)
	Light Oak (suffix LO)
	Light Walnut (suffix LWA)
	Pearwood (suffix P)
	Reff Dark Cherry (suffix V314)
	Rosewood (suffix RO)
	Teak (suffix TK)
	<i>Polished Coated marble top finishes:</i>
	Arabescato: white-grey (suffix MA)
	Calacatta: white-grey/beige (suffix MC)
	Carrara: white-grey (suffix GC)
	Empire Beige: beige (suffix GB)
	Espresso: dark brown (suffix ME)
	Grey Marble: light grey (suffix GG)
	Grigio Marquina: warm grey (suffix MG)
	Nero Marquina: black (suffix MN)
	Verde Alpi: green (suffix MV)
	<i>Satin Coated marble top finishes:</i>
	Arabescato: white-grey (suffix MAS)
	Calacatta: white-grey/beige (suffix MCS)
	Carrara: white-grey (suffix GCS)
	Empire Beige: beige (suffix GBS)
	Espresso: dark brown (suffix MES)
	Grey Marble: light grey (suffix GCS)
	Grigio Marquina: warm grey (suffix MGS)
	Nero Marquina: black (suffix MNS)
	Verde Alpi: green (suffix MVS)
	<i>Natural marble top finishes:</i>
	Calacatta: white-grey/beige (suffix NC)
	Carrara: white-grey (suffix NGC)
	<i>Granite top finish:</i>
	Black Andes: black (suffix GA)
	<i>Engineered Stone:</i>
	Vetro Bianco: white (suffix VB)
	<i>Slate top finish:</i>
	Slate, natural (suffix SN)



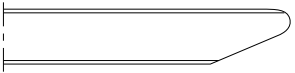
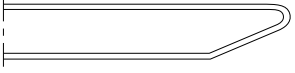

Note:
Saarinen tables are part of a collection. Please refer to Saarinen side chairs, lounge seating, and executive chairs on beginning on page 242.

- Specify:*
1. Pattern number
 2. Top selection
 3. Base finish selection

Construction



<i>Maintenance:</i> See pages 28-29.	<i>Base:</i> Heavy molded cast aluminum, strap-polished. Black and white bases are coated in a tough, abrasion-resistant Rilsan finish. Platinum bases consist of a highly resilient polyurethane enamel wet coat with a clear satin finish.	<i>Marble and Laminate Tops:</i> Bevel-edged satin smooth laminate or marble. 3/4" thick coated marble tops have transparent polyester coating to help eliminate use-associated stains. 3/4" thick natural marble tops and granite tops have protective sealer. Laminate tops are 1.06" thick.	<i>Engineered Stone:</i> Polished, bright white surface is nonporous and more compact than most granites. Comprised of 93% fused quartz. It does not yellow or stain and is scratch resistant.
<i>Note:</i> Top and base shipped in separate packages. The Knoll logo is stamped into the base of the Saarinen tables. Tops have nameplate with designer's signature. Not suitable for outdoor use.	<i>Base Measurements:</i> 174TO, 175TO: width is 31.3" and depth is 23"	<i>Laminate edge detail:</i> 	<i>Slate:</i> Beveled edge, 3/4" thick natural cleft slate.
Marbles with a coating will yellow over time.		<i>Marble edge detail:</i> 	<i>Note:</i> Vetro Bianco (VBO) top for outdoor use is only available on 162TR, 164TR, 169TR, 172TR, 173TR, 174TO tables. 162TR, 164TR, 172TR, 173TR, and 174TO use a phenolic subtop with exposed black edged and white laminate faces. Stainless steel hardware will be used for all connections.
Saarinen Dining Tables with Laminate, Natural Marble, Veneer or Granite tops are Greenguard certified.			<i>Veneer Tops:</i> Tops are constructed of veneered medium density fiberboard with a cathedral grain pattern in various clear or toned stains. Oval dining tops are 1 1/4" thick. Edges are 1/4" solid wood to match face veneer.

Eero Saarinen Round End and Coffee Tables



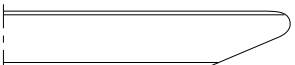

	description	w	d	h	weight	top
<p><i>Designer(s):</i> Eero Saarinen, 1957</p> 	<p>160TR Small round side table, intermediate height</p> 	16 1/4"		20"	12 lbs.	Laminate
		16 1/4"		20"	21 lbs.	Natural marble
		16 1/4"		20"	21 lbs.	Coated marble
		16 1/4"		20"	21 lbs.	Coated marble
		16 1/4"		20"	21 lbs.	Coated marble
		16 1/4"		20"	21 lbs.	Coated marble
		16 1/4"		20"	21 lbs.	Coated marble
		16 1/4"		20"	21 lbs.	Coated marble
		16 1/4"		20"	21 lbs.	Vetro Bianco
		16 1/4"		20"	25 lbs.	Granite
		16 1/4"		20"	21 lbs.	Natural marble
		16 1/4"		20"	14 lbs.	Veneer
		16 1/4"		20"	14 lbs.	Pearwood
		16 1/4"		20"	21 lbs.	Slate, natural
		16 1/4"		20"	14 lbs.	Veneer
	<p>162TR Medium round coffee table, low level</p> 	35 1/4"		15 1/4"	40 lbs.	Laminate
		35 1/4"		15 1/4"	88 lbs.	Natural marble
		35 1/4"		15 1/4"	88 lbs.	Coated marble
		35 1/4"		15 1/4"	88 lbs.	Coated marble
		35 1/4"		15 1/4"	43 lbs.	Veneer
		35 1/4"		15 1/4"	88 lbs.	Vetro Bianco
		35 1/4"		15 1/4"	43 lbs.	Veneer
		35 1/4"		15 1/4"	88 lbs.	Coated marble
		35 1/4"		15 1/4"	43 lbs.	Pearwood
		35 1/4"		15 1/4"	88 lbs.	Coated marble
		35 1/4"		15 1/4"	88 lbs.	Coated marble
		35 1/4"		15 1/4"	96 lbs.	Granite
		35 1/4"		15 1/4"	88 lbs.	Coated marble
		35 1/4"		15 1/4"	88 lbs.	Natural marble
		35 1/4"		15 1/4"	88 lbs.	Slate, natural
<p><i>Designer(s):</i> Eero Saarinen, 1957</p>	<p>163TR Small round side table, intermediate height</p> 	20"		20"	16 lbs.	Laminate
		20"		20"	30 lbs.	Natural marble
		20"		20"	30 lbs.	Coated marble
		20"		20"	30 lbs.	Coated marble
		20"		20"	30 lbs.	Coated marble

pattern no.	
160TR-(F2)-(1, 2, PL)	\$968.
160TR-(NGC)-(1, 2, PL)	1,166.
160TR-(GC, GCS, GB, GBS)-(1, 2, PL)	1,277.
160TR-(MN, MNS, MA, MAS, GG, GGS)-(1, 2, PL)	1,341.
160TR-(MC, MCS)-(1, 2, PL)	1,406.
160TR-(MG, MGS)-(1, 2, PL)	1,578.
160TR-(ME, MES)-(1, 2, PL)	1,626.
160TR-(MV, MVS)-(1, 2, PL)	1,675.
160TR-(VB)-(1, 2, PL)	1,698.
160TR-(GA)-(1, 2, PL)	2,217.
160TR-(NC)-(1, 2, PL)	2,255.
160TR-(LO, LWA, D, V314)-(1, 2, PL)	2,282.
160TR-(P)-(1, 2, PL)	2,601.
160TR-(SN)-(1, 2, PL)	3,078.
160TR-(RO, TK)-(1, 2, PL)	3,100.
162TR-(F2)-(1, 2, PL)	2,629.
162TR-(NGC)-(1, 2, PL)	2,985.
162TR-(GC, GCS, GB, GBS)-(1, 2, PL)	3,500.
162TR-(MG, MGS)-(1, 2, PL)	3,866.
162TR-(LO, LWA, D, V314)-(1, 2, PL)	3,871.
162TR-(VB)-(1, 2, PL)	4,115.
162TR-(RO, TK)-(1, 2, PL)	4,385.
162TR-(MN, MNS, MA, MAS, GG, GGS)-(1, 2, PL)	4,415.
162TR-(P)-(1, 2, PL)	4,423.
162TR-(MC, MCS)-(1, 2, PL)	4,635.
162TR-(ME, MES)-(1, 2, PL)	4,695.
162TR-(GA)-(1, 2, PL)	5,170.
162TR-(MV, MVS)-(1, 2, PL)	6,008.
162TR-(NC)-(1, 2, PL)	6,299.
162TR-(SN)-(1, 2)	6,926.
163TR-(F2)-(1, 2, PL)	1,140.
163TR-(NGC)-(1, 2, PL)	1,272.
163TR-(GC, GCS, GB, GBS)-(1, 2, PL)	1,431.
163TR-(MN, MNS, MA, MAS, GG, GGS)-(1, 2, PL)	1,544.

Order Code	Ordering Information
<i>Example:</i> 160TR-MV-2	
161TO Saarinen side table	<i>Base finishes:</i> Black (suffix 1) Platinum (suffix PL) ☑ White (suffix 2)
MV Verdi Alpi Marble	<i>Laminate top finish:</i> ☑ White (suffix F2)
2 White	<i>Veneer Finishes:</i> Ebonyed Walnut (suffix D) ☑ Light Oak (suffix LO) Light Walnut (suffix LWA) Reff Dark Cherry (suffix V314) Pearwood (suffix P) Rosewood (suffix RO) Teak (suffix TK)
	<i>Polished Coated marble top finishes:</i> Arabescato: white-grey (suffix MA) Calacatta: white-grey/beige (suffix MC) Carrara: white-grey (suffix GC) Empire Beige: beige (suffix GB) Espresso: dark brown (suffix ME) Grey Marble: light grey (suffix GG) Grigio Marquina: warm grey (suffix MG) Nero Marquina: black (suffix MN) Verde Alpi: green (suffix MV)
	<i>Natural marble top finishes:</i> Calacatta: white-grey/beige (suffix NC) Carrara: white-grey (suffix NGC)
	<i>Granite top finish:</i> Black Andes: black (suffix GA)
	<i>Engineered Stone:</i> Vetro Bianco: white (suffix VB)
	<i>Slate top finish:</i> Slate, natural (suffix SN)
	<i>Satin Coated marble top finishes:</i> Arabescato: white-grey (suffix MAS) Calacatta: white-grey/beige (suffix MCS) Carrara: hite-grey (suffix GCS) Empire Beige: beige (suffix GBS) Espresso: dark brown (suffix MES) Grey Marble: light grey (suffix GGS) Grigio Marquina: warm grey (suffix MGS) Nero Marquina: black (suffix MNS) Verde Alpi: green (suffix MVS)
	<i>Natural marble top finishes:</i> ☑ KnollStudio 20-Day Program: Saarinen 169TR and 163TR side tables are available on the KnollStudio 20-day program in select finishes. For specific information, consult pages 30-33.



Maintenance:	Construction
See pages 28-29.	<i>Base:</i> Heavy molded cast aluminum, strap-polished. Black and white bases are coated in a tough, abrasion-resistant Rilsan finish. Platinum bases consist of a highly resilient polyurethane enamel wet coat with a clear satin finish.
<i>Note:</i> Top and base shipped in separate packages. The Knoll logo is stamped into the base of the Saarinen tables. Tops have a nameplate with the designers signature.	<i>Laminate and Marble Tops:</i> Bevel-edged satin smooth laminate or marble. 3/4" thick coated marble tops have transparent polyester coating to help eliminate use-associated stains. 3/4" thick natural marble tops and granite tops have protective sealer. Laminate tops are 1.06" thick.
Not suitable for outdoor use.	<i>Veneer Tops:</i> Tops are constructed of veneered medium density fiberboard with a cathedral grain pattern in various clear or toned or stains. All tops are 1 1/16" thick.
Marbles with a coating will yellow over time.	<i>Engineered Stone:</i> Polished, bright white surface is nonporous and more compact than most granites. Comprised of 93% fused quartz. It does not yellow or stain and is scratch resistant. Suitable for outdoors.
Saarinen Round End and Coffee Tables with Laminate, Natural Marble, Veneer or Granite tops are Greenguard certified.	<i>Slate:</i> Beveled edge, 3/4" thick natural cleft slate.
	<i>Note:</i> Vetro Bianco (VBO) top for outdoor use is only available on 162TR, 164TR, 169TR, 172TR, 173TR, 174TO tables. 162TR, 164TR, 172TR, 173TR, and 174TO use a phenolic subtop with exposed black edges and white laminate faces. Stainless steel hardware will be used for all connections.
	<i>Laminate edge detail:</i> 
	<i>Marble edge detail:</i> 

Eero Saarinen Round End and Coffee Tables

	description	w	d	h	weight	top		
<p><i>Designer(s):</i> Eero Saarinen, 1957</p> 	<p>163TR Small round side table, intermediate height</p> 	20"		20"	30 lbs.	Coated marble		
		20"		20"	30 lbs.	Coated marble		
		20"		20"	30 lbs.	Vetro Bianco		
		20"		20"	30 lbs.	Coated marble		
		20"		20"	30 lbs.	Coated marble		
		20"		20"	17 lbs.	Veneer		
		20"		20"	33 lbs.	Granite		
		20"		20"	30 lbs.	Natural marble		
		20"		20"	17 lbs.	Pearwood		
		20"		20"	17 lbs.	Veneer		
		20"		20"	30 lbs.	Slate, natural		
			<p>169TR Small round side table, low height</p> 	20"		13 3/4"	14 lbs.	Laminate
				20"		13 3/4"	29 lbs.	Natural marble
				20"		13 3/4"	29 lbs.	Coated marble
				20"		13 3/4"	29 lbs.	Coated marble
20"				13 3/4"	29 lbs.	Coated marble		
20"				13 3/4"	29 lbs.	Coated marble		
20"				13 3/4"	29 lbs.	Coated marble		
20"				13 3/4"	29 lbs.	Coated marble		
20"				13 3/4"	16 lbs.	Veneer		
20"				13 3/4"	32 lbs.	Granite		
20"				13 3/4"	29 lbs.	Natural marble		
20"				13 3/4"	16 lbs.	Pearwood		
20"				13 3/4"	16 lbs.	Veneer		
20"				13 3/4"	29 lbs.	Slate, natural		

pattern no.	
163TR-(MC, MCS)-(1, 2, PL)	\$1,620.
163TR-(MG, MGS)-(1, 2, PL)	1,880.
163TR-(VB)-(1, 2, PL)	1,915.
163TR-(ME, MES)-(1, 2, PL)	2,087.
163TR-(MV, MVS)-(1, 2, PL)	2,198.
163TR-(LO, LWA, D, V314)-(1, 2, PL)	2,427.
163TR-(GA)-(1, 2, PL)	2,626.
163TR-(NC)-(1, 2, PL)	2,664.
163TR-(P)-(1, 2, PL)	2,774.
163TR-(TK, RO)-(1, 2, PL)	3,209.
163TR-(SN)-(1, 2, PL)	3,293.
169TR-(F2)-(1, 2, PL)	1,045.
169TR-(NGC)-(1, 2, PL)	1,241.
169TR-(GC, GCS, GB, GBS)-(1, 2, PL)	1,389.
169TR-(MN, MNS, MA, MAS, GG, GGS)-(1, 2, PL)	1,501.
169TR-(MC, MCS)-(1, 2, PL)	1,577.
169TR-(MV, MVS)-(1, 2, PL)	1,993.
169TR-(MG, MGS)-(1, 2, PL)	1,999.
169TR-(ME, MES)-(1, 2, PL)	2,206.
169TR-(LO, LWA, D, V314)-(1, 2, PL)	2,539.
169TR-(GA)-(1, 2, PL)	2,574.
169TR-(NC)-(1, 2, PL)	2,611.
169TR-(P)-(1, 2, PL)	2,889.
169TR-(RO, TK)-(1, 2, PL)	3,285.
169TR-(SN)-(1, 2, PL)	3,394.

Order Code	Ordering Information
<i>Example:</i> 160TR-MV-2	
161TO Saarinen side table	<i>Base finishes:</i> Black (suffix 1) Platinum (suffix PL) ☑ White (suffix 2)
MV Verdi Alpi Marble	<i>Laminate top finish:</i> ☑ White (suffix F2)
2 White	<i>Veneer Finishes:</i> Ebonized Walnut (suffix D) ☑ Light Oak (suffix LO) Light Walnut (suffix LWA) Reff Dark Cherry (suffix V314) Pearwood (suffix P) Rosewood (suffix RO) Teak (suffix TK)
	<i>Polished Coated marble top finishes:</i> Arabescato: white-grey (suffix MA) Calacatta: white-grey/beige (suffix MC) Carrara: white-grey (suffix GC) Empire Beige: beige (suffix GB) Espresso: dark brown (suffix ME) Grey Marble: light grey (suffix GG) Grigio Marquina: warm grey (suffix MG) Nero Marquina: black (suffix MN) Verde Alpi: green (suffix MV)
	<i>Natural marble top finishes:</i> Calacatta: white-grey/beige (suffix NC) Carrara: white-grey (suffix NGC)
	<i>Granite top finish:</i> Black Andes: black (suffix GA)
	<i>Engineered Stone:</i> Vetro Bianco: white (suffix VB)
	<i>Slate top finish:</i> Slate, natural (suffix SN)
	<i>Satin Coated marble top finishes:</i> Arabescato: white-grey (suffix MAS) Calacatta: white-grey/beige (suffix MCS) Carrara: hite-grey (suffix GCS) Empire Beige: beige (suffix GBS) Espresso: dark brown (suffix MES) Grey Marble: light grey (suffix GGS) Grigio Marquina: warm grey (suffix MGS) Nero Marquina: black (suffix MNS) Verde Alpi: green (suffix MVS)
	<i>Natural marble top finishes:</i> ☑ KnollStudio 20-Day Program: Saarinen 169TR and 163TR side tables are available on the KnollStudio 20-day program in select finishes. For specific information, consult pages 30-33.

Maintenance:	Construction
See pages 28-29.	<i>Base:</i> Heavy molded cast aluminum, strap-polished. Black and white bases are coated in a tough, abrasion-resistant Rilsan finish. Platinum bases consist of a highly resilient polyurethane enamel wet coat with a clear satin finish.
<i>Note:</i> Top and base shipped in separate packages. The Knoll logo is stamped into the base of the Saarinen tables. Tops have a nameplate with the designers signature.	<i>Laminate and Marble Tops:</i> Bevel-edged satin smooth laminate or marble. 3/4" thick coated marble tops have transparent polyester coating to help eliminate use-associated stains. 3/4" thick natural marble tops and granite tops have protective sealer. Laminate tops are 1.06" thick.
Not suitable for outdoor use.	<i>Veneer Tops:</i> Tops are constructed of veneered medium density fiberboard with a cathedral grain pattern in various clear or toned or stains. All tops are 1 1/16" thick.
Marbles with a coating will yellow over time.	<i>Engineered Stone:</i> Polished, bright white surface is nonporous and more compact than most granites. Comprised of 93% fused quartz. It does not yellow or stain and is scratch resistant. Suitable for outdoors.
Saarinen Round End and Coffee Tables with Laminate, Natural Marble, Veneer or Granite tops are Greenguard certified.	<i>Slate:</i> Beveled edge, 3/4" thick natural cleft slate.
	<i>Note:</i> Vetro Bianco (VBO) top for outdoor use is only available on 162TR, 164TR, 169TR, 172TR, 173TR, 174TO tables. 162TR, 164TR, 172TR, 173TR, and 174TO use a phenolic subtop with exposed black edges and white laminate faces. Stainless steel hardware will be used for all connections.
	<i>Laminate edge detail:</i> 
	<i>Marble edge detail:</i> 

Eero Saarinen

Oval End and Coffee Tables

Designer(s):
Eero Saarinen, 1957



description	w	d	h	weight	top
161TO Oval side table, intermediate height 	22 1/2"	15"	20"	15 lbs.	Laminate
	22 1/2"	15"	20"	28 lbs.	Natural marble
	22 1/2"	15"	20"	28 lbs.	Coated marble
	22 1/2"	15"	20"	28 lbs.	Coated marble
	22 1/2"	15"	20"	28 lbs.	Coated marble
	22 1/2"	15"	20"	28 lbs.	Coated marble
	22 1/2"	15"	20"	28 lbs.	Coated marble
	16 1/4"		20"	28 lbs.	Vetro Bianco
	22 1/2"	15"	20"	28 lbs.	Coated marble
	22 1/2"	15"	20"	16 lbs.	Veneer
	22 1/2"	15"	20"	29 lbs.	Granite
	22 1/2"	15"	20"	28 lbs.	Natural marble
	22 1/2"	15"	20"	16 lbs.	Pearwood
	22 1/2"	15"	20"	16 lbs.	Veneer
16 1/4"		20"	28 lbs.	Slate, natural	
162TO Oval coffee table, low level 	42 1/4"	27 1/2"	15 1/4"	37 lbs.	Laminate
	42 1/4"	27 1/2"	15 1/4"	80 lbs.	Natural marble
	42 1/4"	27 1/2"	15 1/4"	80 lbs.	Coated marble
	42 1/4"	27 1/2"	15 1/4"	80 lbs.	Coated marble
	42 1/4"	27 1/2"	15 1/4"	40 lbs.	Veneer
	42 1/4"	27 1/2"	15 1/4"	80 lbs.	Vetro Bianco
	42 1/4"	27 1/2"	15 1/4"	80 lbs.	Coated marble
	42 1/4"	27 1/2"	15 1/4"	80 lbs.	Coated marble
	42 1/4"	27 1/2"	15 1/4"	40 lbs.	Veneer
	42 1/4"	27 1/2"	15 1/4"	40 lbs.	Pearwood
	42 1/4"	27 1/2"	15 1/4"	80 lbs.	Coated marble
	42 1/4"	27 1/2"	15 1/4"	86 lbs.	Granite
	42 1/4"	27 1/2"	15 1/4"	80 lbs.	Coated marble
	42 1/4"	27 1/2"	15 1/4"	80 lbs.	Slate, natural
	42 1/4"	27 1/2"	15 1/4"	80 lbs.	Natural marble

pattern no.	
161TO-(F2)-(1, 2, PL)	\$1,169.
161TO-(NGC)-(1, 2, PL)	1,173.
161TO-(GC, GCS, GB, GBS)-(1, 2, PL)	1,286.
161TO-(MN, MNS, MA, MAS, GG, GGS)-(1, 2, PL)	1,323.
161TO-(MC, MCS)-(1, 2, PL)	1,388.
161TO-(MV, MVS)-(1, 2, PL)	1,571.
161TO-(MG, MGS)-(1, 2, PL)	1,728.
161TO-(VB)-(1, 2, PL)	1,782.
161TO-(ME, MES)-(1, 2, PL)	1,896.
161TO-(LO, LWA, D, V314)-(1, 2, PL)	2,536.
161TO-(GA)-(1, 2, PL)	2,558.
161TO-(NC)-(1, 2, PL)	2,616.
161TO-(P)-(1, 2, PL)	2,900.
161TO-(RO, TK)-(1, 2, PL)	3,151.
161TO-(SN)-(1, 2, PL)	3,580.
162TO-(F2)-(1, 2, PL)	2,641.
162TO-(NGC)-(1, 2, PL)	3,336.
162TO-(GC, GCS, GB, GBS)-(1, 2, PL)	3,789.
162TO-(MG, MGS)-(1, 2, PL)	3,858.
162TO-(LO, LWA, D, V314)-(1, 2, PL)	3,871.
162TO-(VB)-(1, 2, PL)	3,922.
162TO-(MN, MNS, MA, MAS, GG, GGS)-(1, 2, PL)	3,982.
162TO-(MC, MCS)-(1, 2, PL)	4,182.
162TO-(RO, TK)-(1, 2, PL)	4,280.
162TO-(P)-(1, 2, PL)	4,424.
162TO-(ME, MES)-(1, 2, PL)	4,599.
162TO-(GA)-(1, 2, PL)	5,269.
162TO-(MV, MVS)-(1, 2, PL)	5,443.
162TO-(SN)-(1, 2, PL)	5,590.
162TO-(NC)-(1, 2, PL)	6,562.

Order Code

Example:	161TO-NGC-2
161TO	Saarinen side table
NGC	Carrara Marble
2	White

Note:
Saarinen tables are part of a collection. Please refer to Saarinen side chairs, lounge seating and executive chairs on pages 242.

Specify:

1. Pattern number
2. Top selection
3. Base finish selection

Ordering Information

Base finishes:

- Black (suffix 1)
- Platinum (suffix PL)
- White (suffix 2)

Laminate top finish:

- White (suffix F2)

Veneer Finishes:

- Ebonized Walnut (suffix D)
- Light Oak (suffix LO)
- Light Walnut (suffix LWA)
- Pearwood (suffix P)
- Reff Dark Cherry (suffix V314)
- Rosewood (suffix RO)
- Teak (suffix TK)

Polished Coated marble top finishes:

- Arabescato: white-grey (suffix MA)
- Calacatta: white-grey/beige (suffix MC)
- Carrara: white-grey (suffix GC)
- Empire Beige: beige (suffix GB)
- Espresso: dark brown (suffix ME)
- Grey Marble: light grey (suffix GG)
- Grigio Marquina: warm grey (suffix MG)
- Nero Marquina: black (suffix MN)
- Verde Alpi: green (suffix MV)

Satin Coated marble top finishes:

- Arabescato: white-grey (suffix MAS)
- Calacatta: white-grey/beige (suffix MCS)
- Carrara: white-grey (suffix GCS)
- Empire Beige: beige (suffix GBS)
- Espresso: dark brown (suffix MES)
- Grey Marble: light grey (suffix GGS)
- Grigio Marquina: warm grey (suffix MGS)
- Nero Marquina: black (suffix MNS)
- Verde Alpi: green (suffix MVS)

Natural marble top finishes:

- Calacatta: white-grey/beige (suffix NC)
- Carrara: white-grey (suffix NGC)

Granite top finish:

- Black Andes: black (suffix GA)

Engineered Stone:

- Vetro Bianco: white (suffix VB)

Slate top finish:

- Slate, natural (suffix SN)

Construction

Maintenance:

See pages 28-29.

Note:

Top and base shipped in separate packages. The Knoll logo is stamped into the base of the Saarinen tables. Tops have a nameplate with the designers signature.

Not suitable for outdoor use.

Marbles with a coating will yellow over time.

Saarinen Oval End and Coffee Tables with Laminate, Natural Marble, Veneer or Granite tops are Greenguard certified.

Base:

Heavy molded cast aluminum, strap-polished. Black and white bases are coated in a tough, abrasion-resistant Rilsan finish. Platinum bases consist of a highly resilient polyurethane enamel wet coat with a clear satin finish.

Base Diameters:

- 161TO: 10.7"
- 162TO: 17"

Laminate and Marble Tops:

Bevel-edged satin smooth laminate or marble. 3/4" thick coated marble tops have transparent polyester coating to help eliminate use-associated stains. 3/4" thick natural marble tops and granite tops have protective sealer. Laminate tops are 1.06" thick.

Laminate edge detail:

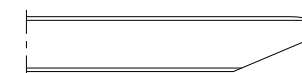

Marble edge detail:

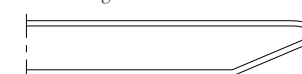

Veneer Tops:

Tops are constructed of veneered medium density fiberboard with a cathedral grain pattern in various clear or toned or stains. All tops are 1 1/16" thick.

Slate:

Beveled edge, 3/4" thick natural cleft slate.

Note:

Vetro Bianco (VBO) top for outdoor use is only available on 162TR, 164TR, 169TR, 172TR, 173TR, 174TO tables. 162TR, 164TR, 172TR, 173TR, and 174TO use a phenolic subtop with exposed black edges and white laminate faces. Stainless steel hardware will be used for all connections.

Eero Saarinen Outdoor Tables

Designer(s):
Eero Saarinen, 1957



description	w	d	h	weight	top
169TR Small round side table, low height 	20"		13 3/4"	29 lbs.	Vetro Bianco
	20"		13 3/4"	29 lbs.	Slate, natural
162TR Medium round coffee table, low level 	35 1/4"		15 1/4"	88 lbs.	Vetro Bianco
	35 1/4"		15 1/4"	88 lbs.	Slate, natural
172TR Small round table, dining height 	35 1/4"		28 1/4"	95 lbs.	Vetro Bianco
	35 1/4"		28 1/4"	95 lbs.	Slate, natural
173TR Medium round table, dining height 	42 1/4"		28 1/4"	125 lbs.	Vetro Bianco
	42 1/4"		28 1/4"	125 lbs.	Slate, natural
164TR Large round table, dining height 	54"		28 1/4"	203 lbs.	Vetro Bianco
174TO Medium oval table, dining height 	78"	47 1/4"	28 1/4"	259 lbs.	Vetro Bianco
	78"	47 1/4"	28 1/4"	259 lbs.	Slate, natural

pattern no.	list
169TR-(VBO)-(1, 2)	\$2,084.
169TR-(SNO)-(1, 2)	3,440.
162TR-(VBO)-(1, 2)	4,330.
162TR-(SNO)-(1, 2)	7,103.
172TR-(VBO)-(1, 2)	4,728.
172TR-(SNO)-(1, 2)	7,533.
173TR-(VBO)-(1, 2)	5,692.
173TR-(SNO)-(1, 2)	8,048.
164TR-VBO-(1, 2)	8,017.
174TO-(VBO)-(1, 2)	11,864.
174TO-(SNO)-(1, 2)	13,792.

Order Code

Example:	173TR-VBO-2
173TR	Saarinen dining table
VBO	Vetro Bianco
2	White

Note:
Saarinen tables are part of a collection. Please refer to Saarinen side chairs, lounge seating, and executive chairs on beginning on page 242.

Specify:

1. Pattern number
2. Top selection
3. Base finish selection

Ordering Information

Base finishes:
 White (suffix 2)
 Black (suffix 1)

Engineered Stone:
 Vetro Bianco (suffix VBO)

Slate top finish:
 Slate, natural (suffix SNO)

Maintenance:
 See pages 28-29.

Note:
 Top and base shipped in separate packages. The Knoll logo is stamped into the base of the Saarinen tables. Tops have nameplate with designer's signature.

Construction

Base:
 Heavy molded cast aluminum, strap-polished. White bases are coated in a tough, abrasion-resistant Rilsan finish.

Base Measurements:
 162TR: 17" diameter
 164TR: 25.984" diameter
 174TO: 31.3"W x 23"D
 173TR and 172TR: 20" diameter
 169TR: 13.5" diameter

Tops:
 3/4" thick bevel-edged Vetro Bianco or Slate top.

Edge detail:

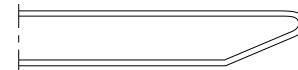

Engineered Stone:
 Polished, bright white surface is nonporous and more compact than most granites. Comprised of 93% fused quartz. It does not yellow or stain and is scratch resistant. Exposed black phenolic sub-top edge with white laminate faces. Suitable for outdoors.

Slate:
 Beveled edge, 1/4" thick natural cleft slate. Black phenolic sub-top with black laminate faces. Suitable for outdoor use.

Designer(s):
 Richard Schultz, 1960

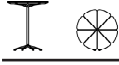
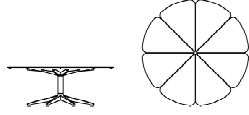
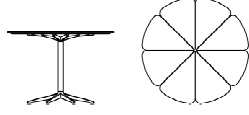

description	w	d	h	weight	top
P320 Petal end table	16"		19"	5 lbs.	Teak
	16"		19"	5 lbs.	White HPDE
P320COV Petal end table cover	–		–	–	–
P321 Petal coffee table	42"		15"	60 lbs.	Teak
	42"		15"	60 lbs.	White HPDE
P321COV Petal coffee table cover	–		–	–	–
P322 Petal dining table	42"		28"	62 lbs.	Teak
	42"		28"	62 lbs.	White HPDE
P322COV Petal dining table cover	–		–	–	–

pattern no.	
P320-K- ()	\$1,577.
P320-W- ()	1,438.
P320COV	414.
P321-K- ()	3,566.
P321-W- ()	3,441.
P321COV	622.
P322-K- ()	3,690.
P322-W- ()	3,566.
P322COV	653.

Order Code

<i>Example:</i> P320-K-W	
P320	Petal side table
K	Teak top
W	White

Specify:

1. Pattern number
2. Top selection
3. Base finish selection

Ordering Information

Base finishes:
 Blue (suffix BLU)
 Chestnut (suffix N)
 Dark Bronze (suffix 14)
 Green (suffix 007)
 Light Bronze (suffix 13)
 Lime Green (suffix LGR)
 Onyx (suffix O)
 Orange (suffix ORG)
 Plum (suffix PLM)
 Sky Blue (suffix 3)
 Warm Bronze (suffix 16)
 Warm Wood (suffix 12)
 Weatherable Silver (suffix S)
 White (suffix W)
 Yellow (suffix YEL)

Construction

Wood top finishes:
 Teak (suffix K)

High Density Polyurethane top finishes:
 White HPDE (suffix W)

Maintenance:
 See pages 28-29.

Base:
 Top spider and base are powder coated cast aluminum. Stem is powder coated stainless steel.

Wood top:
 Vertical grain teak with natural finish.

HPDE top:
 Machined high density polyurethane.



Note:
 Teak tops will patina over time if left outdoors and will turn a silvery grey color.

Glides:
 Molded nylon glides are included on P321 and P322 models only.

Richard Schultz
1966 Collection® Dining Tables

Designer(s):
Richard Schultz, 1966

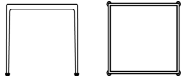
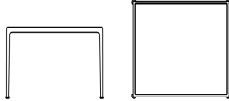
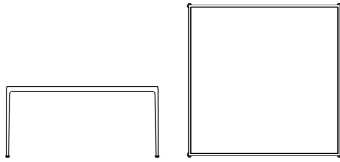
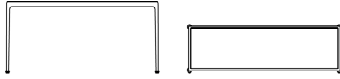
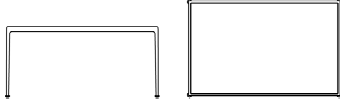

description	w	d	h	weight	top
1966-24H 1966 Dining Table 	28"	28"	28"	39 lbs.	Glass
	28"	28"	28"	36 lbs.	Porcelain
	28"	28"	28"	38 lbs.	Teak
	28"	28"	28"	37 lbs.	Fiberglass
1966-24HCOV 1966 Dining Table cover	-	-	-	-	-
1966-26H 1966 Dining Table 	38"	38"	28"	63 lbs.	Glass
	38"	38"	28"	50 lbs.	Porcelain
	38"	38"	28"	50 lbs.	Teak
	38"	38"	28"	49 lbs.	Fiberglass
1966-26HCOV 1966 Dining Table cover	-	-	-	-	-
1966-60H 1966 Dining Table 	60"	60"	28"	143 lbs.	Glass
	60"	60"	28"	131 lbs.	Porcelain
	60"	60"	28"	120 lbs.	Teak
	60"	60"	28"	106 lbs.	Fiberglass
1966-60HCOV 1966 Dining Table cover	-	-	-	-	-
1966-20H 1966 Dining Table 	60"	18"	28"	50 lbs.	Glass
	60"	18"	28"	61 lbs.	Porcelain
	60"	18"	28"	53 lbs.	Teak
	60"	18"	28"	47 lbs.	Fiberglass
1966-20HCOV 1966 Dining Table cover	-	-	-	-	-
1966-28H 1966 Dining Table 	60"	38"	28"	91 lbs.	Glass
	60"	38"	28"	93 lbs.	Porcelain
	60"	38"	28"	77 lbs.	Teak
	60"	38"	28"	71 lbs.	Fiberglass
1966-28HCOV 1966 Dining Table cover	-	-	-	-	-
1966-90H 1966 Dining Table 	90"	38"	28"	137 lbs.	Glass
	90"	38"	28"	TBD lbs.	Porcelain
	90"	38"	28"	115 lbs.	Teak
	90"	38"	28"	110 lbs.	Fiberglass
1966-90HCOV 1966 Dining Table cover	-	-	-	-	-

pattern no.	
1966-24H-G-(-)(-)	\$2,238.
1966-24H-P-(-)(-)	2,893.
1966-24H-K-(-)	3,013.
1966-24H-F-(-)(-)	3,132.
1966-24HCOV	631.
1966-26H-G-(-)(-)	2,954.
1966-26H-P-(-)(-)	3,521.
1966-26H-K-(-)	4,028.
1966-26H-F-(-)(-)	4,325.
1966-26HCOV	750.
1966-60H-G-(-)(-)	5,191.
1966-60H-P-(-)(-)	6,085.
1966-60H-K-(-)	6,772.
1966-60H-F-(-)(-)	7,220.
1966-60HCOV	939.
1966-20H-G-(-)(-)	2,518.
1966-20H-P-(-)(-)	3,174.
1966-20H-K-(-)	3,294.
1966-20H-F-(-)(-)	3,413.
1966-20HCOV	731.
1966-28H-G-(-)(-)	3,401.
1966-28H-P-(-)(-)	4,177.
1966-28H-K-(-)	4,954.
1966-28H-F-(-)(-)	5,191.
1966-28HCOV	853.
1966-90H-G-(-)(-)	4,833.
1966-90H-P-(-)(-)	5,910.
1966-90H-K-(-)	6,414.
1966-90H-F-(-)(-)	6,862.
1966-90HCOV	1,107.

Order Code

Ordering Information

Example: **1966-24H-P-W-W**
1966-24H 28" x 28" dining table
P Porcelain top
W White top
W White frame

Base finishes:
 Blue (suffix BLU)
 Chestnut (suffix N)
 Dark Bronze (suffix 14)
 Green (suffix 007)
 Light Bronze (suffix 13)
 Lime Green (suffix LGR)
 Onyx (suffix O)
 Orange (suffix ORG)
 Plum (suffix PLM)
 Sky Blue (suffix 3)
 Warm Bronze (suffix 16)
 Warm Wood (suffix 12)
 Weatherable Silver (suffix S)
 White (suffix W)
 Yellow (suffix YEL)

Porcelain top finishes:
 White (suffix W)
 Brown (suffix B)
 Marine Blue (suffix M)
 Warm Wood (suffix 12)
 Light Bronze (suffix 13)
 Dark Bronze (suffix 14)
 Warm Bronze (suffix 16)

Fiberglass top finishes:
 White (suffix W)

Glass top finishes:
 Clear glass (suffix C)
 Etched glass (suffix E)

Specify:

1. Pattern number
2. Top material
3. Top finish selection
4. Base finish selection

Construction

Wood top finishes:
 Teak (suffix K)

Maintenance:
 See pages 28-29.

Frame:
 Frame is aluminum castings and extrusions welded together. Finished in highly durable weather resistant polyester powder coat paint. Y-shaped stainless steel connectors attach tops on corners.

Glass Top:
 3/8" beveled glass top available in clear or acid etched.

Porcelain Top:
 .08" thick steel plate with a porcelain enamel layer comprised of glass particles, baked to melt into a .002" smooth surface. Honey comb subtop comprised of metal or particle wood board provides additional support.

Teak:
 1" natural teak.

Fiberglass Top:
 1" thick fiberglass available in white finish.

Note:
 Teak tops will patina over time if left outdoors and will turn a silvery grey color.

Glides:
 Clear butyrate plastic.

Richard Schultz
1966 Collection® Counter Height Tables

Designer(s):
Richard Schultz, 1966

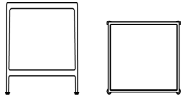
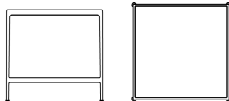
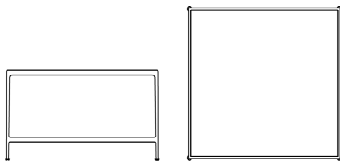
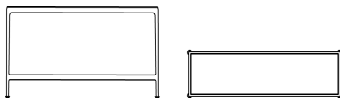
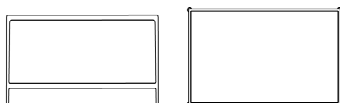

description	w	d	h	weight	top
1966-24C 1966 Counter Height Table 	28"	28"	36"	47 lbs.	Glass
	28"	28"	36"	41 lbs.	Porcelain
	28"	28"	36"	44 lbs.	Teak
	28"	28"	36"	36 lbs.	Fiberglass
1966-24CCOV 1966 Counter Height Table cover	-	-	-	-	-
1966-26C 1966 Counter Height Table 	38"	38"	36"	71 lbs.	Glass
	38"	38"	36"	55 lbs.	Porcelain
	38"	38"	36"	56 lbs.	Teak
	38"	38"	36"	47 lbs.	Fiberglass
1966-26CCOV 1966 Counter Height Table cover	-	-	-	-	-
1966-60C 1966 Counter Height Table 	60"	60"	36"	151 lbs.	Glass
	60"	60"	36"	141 lbs.	Porcelain
	60"	60"	36"	129 lbs.	Teak
	60"	60"	36"	106 lbs.	Fiberglass
1966-60CCOV 1966 Counter Height Table cover	-	-	-	-	-
1966-20C 1966 Counter Height Table 	60"	18"	36"	58 lbs.	Glass
	60"	18"	36"	69 lbs.	Porcelain
	60"	18"	36"	61 lbs.	Teak
	60"	18"	36"	45 lbs.	Fiberglass
1966-20CCOV 1966 Counter Height Table cover	-	-	-	-	-
1966-28C 1966 Counter Height Table 	60"	38"	36"	100 lbs.	Glass
	60"	38"	36"	102 lbs.	Porcelain
	60"	38"	36"	86 lbs.	Teak
	60"	38"	36"	66 lbs.	Fiberglass
1966-28CCOV 1966 Counter Height Table cover	-	-	-	-	-

pattern no.	
1966-24C-G-(-)(-)	\$2,745.
1966-24C-P-(-)(-)	3,401.
1966-24C-K-(-)	3,521.
1966-24C-F-(-)(-)	3,640.
1966-24CCOV	731.
1966-26C-G-(-)(-)	3,460.
1966-26C-P-(-)(-)	4,028.
1966-26C-K-(-)	4,534.
1966-26C-F-(-)(-)	4,833.
1966-26CCOV	851.
1966-60C-G-(-)(-)	6,085.
1966-60C-P-(-)(-)	6,982.
1966-60C-K-(-)	7,666.
1966-60C-F-(-)(-)	8,114.
1966-60CCOV	1,070.
1966-20C-G-(-)(-)	3,025.
1966-20C-P-(-)(-)	3,681.
1966-20C-K-(-)	3,799.
1966-20C-F-(-)(-)	3,920.
1966-20CCOV	831.
1966-28C-G-(-)(-)	4,057.
1966-28C-P-(-)(-)	4,833.
1966-28C-K-(-)	5,608.
1966-28C-F-(-)(-)	5,847.
1966-28CCOV	952.

Order Code

<i>Example:</i> 1966-26C-K-O
1966-26C 38" x 38" counter height table
K Teak top
O Onyx frame

Specify:

1. Pattern number
2. Top material
3. Top finish selection
4. Base finish selection

Ordering Information

Base finishes: Blue (suffix BLU) Chestnut (suffix N) Dark Bronze (suffix 14) Green (suffix 007) Light Bronze (suffix 13) Lime Green (suffix LGR) Onyx (suffix O) Orange (suffix ORG) Plum (suffix PLM) Sky Blue (suffix 3) Warm Bronze (suffix 16) Warm Wood (suffix 12) Weatherable Silver (suffix S) White (suffix W) Yellow (suffix YEL)	Porcelain top finishes: White (suffix W) Brown (suffix B) Marine Blue (suffix M) Warm Wood (suffix 12) Light Bronze (suffix 13) Dark Bronze (suffix 14) Warm Bronze (suffix 16)	Fiberglass top finishes: White (suffix W) Glass top finishes: Clear glass (suffix C) Etched glass (suffix E)
---	---	--

Construction

Wood top finishes: Teak (suffix K) Maintenance: See pages 28-29.	Frame: Frame is aluminum castings and extrusions welded together. Finished in highly durable weather resistant polyester powder coat paint. Y-shaped stainless steel connectors attach tops on corners. Glass Top: 3/8" beveled glass top available in clear or acid etched. Porcelain Top: .08" thick steel plate with a porcelain enamel layer comprised of glass particles, baked to melt into a .002" smooth surface. Honey comb subtop comprised of metal or particle wood board provides additional support.	Teak: 1" natural teak. Fiberglass Top: 1" thick fiberglass available in white finish. Note: Teak tops will patina over time if left outdoors and will turn a silvery grey color. Glides: Clear butyrate plastic.
---	--	---

Richard Schultz
1966 Collection® Bar Height Tables

Designer(s):
Richard Schultz, 1966

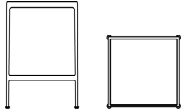
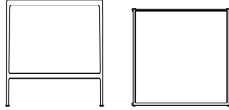
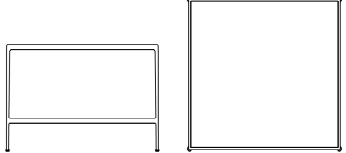
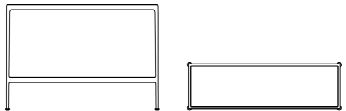
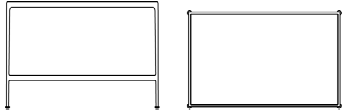

description	w	d	h	weight	top
1966-24B 1966 Bar Height Table 	28"	28"	42"	49 lbs.	Glass
	28"	28"	42"	44 lbs.	Porcelain
	28"	28"	42"	47 lbs.	Teak
	28"	28"	42"	39 lbs.	Fiberglass
1966-24BCOV 1966 Bar Height Table cover	–	–	–	–	–
1966-26B 1966 Bar Height Table 	38"	38"	42"	73 lbs.	Glass
	38"	38"	42"	58 lbs.	Porcelain
	38"	38"	42"	59 lbs.	Teak
	38"	38"	42"	50 lbs.	Fiberglass
1966-26BCOV 1966 Bar Height Table cover	–	–	–	–	–
1966-60B 1966 Bar Height Table 	60"	60"	42"	153 lbs.	Glass
	60"	60"	42"	145 lbs.	Porcelain
	60"	60"	42"	133 lbs.	Teak
	60"	60"	42"	110 lbs.	Fiberglass
1966-60BCOV 1966 Bar Height Table cover	–	–	–	–	–
1966-20B 1966 Bar Height Table 	60"	18"	42"	60 lbs.	Glass
	60"	18"	42"	71 lbs.	Porcelain
	60"	18"	42"	63 lbs.	Teak
	60"	18"	42"	48 lbs.	Fiberglass
1966-20BCOV 1966 Bar Height Table cover	–	–	–	–	–
1966-28B 1966 Bar Height Table 	60"	38"	42"	103 lbs.	Glass
	60"	38"	42"	105 lbs.	Porcelain
	60"	38"	42"	89 lbs.	Teak
	60"	38"	42"	70 lbs.	Fiberglass
1966-28BCOV 1966 Bar Height Table cover	–	–	–	–	–

pattern no.	
1966-24B-G-(-)(-)	\$2,864.
1966-24B-P-(-)(-)	3,521.
1966-24B-K-(-)	3,640.
1966-24B-F-(-)(-)	3,759.
1966-24BCOV	805.
1966-26B-G-(-)(-)	3,580.
1966-26B-P-(-)(-)	4,146.
1966-26B-K-(-)	4,654.
1966-26B-F-(-)(-)	4,954.
1966-26BCOV	944.
1966-60B-G-(-)(-)	6,206.
1966-60B-P-(-)(-)	7,100.
1966-60B-K-(-)	7,786.
1966-60B-F-(-)(-)	8,234.
1966-60BCOV	1,182.
1966-20B-G-(-)(-)	3,145.
1966-20B-P-(-)(-)	3,799.
1966-20B-K-(-)	3,920.
1966-20B-F-(-)(-)	4,039.
1966-20BCOV	931.
1966-28B-G-(-)(-)	4,177.
1966-28B-P-(-)(-)	4,954.
1966-28B-K-(-)	5,727.
1966-28B-F-(-)(-)	5,966.
1966-28BCOV	1,058.

Order Code

<i>Example:</i>	1966-20B-F-W-6
1966-20B	60" x 18" bar height table
F	Fiberglass top
W	White top
6	Choice White frame

Specify:

1. Pattern number
2. Top material
3. Top finish selection
4. Base finish selection

Ordering Information

<i>Base finishes:</i> Blue (suffix BLU) Chestnut (suffix N) Dark Bronze (suffix 14) Green (suffix 007) Light Bronze (suffix 13) Lime Green (suffix LGR) Onyx (suffix O) Orange (suffix ORG) Plum (suffix PLM) Sky Blue (suffix 3) Warm Bronze (suffix 16) Warm Wood (suffix 12) Weatherable Silver (suffix S) White (suffix W) Yellow (suffix YEL)	<i>Porcelain top finishes:</i> White (suffix W) Brown (suffix B) Marine Blue (suffix M) Warm Wood (suffix 12) Light Bronze (suffix 13) Dark Bronze (suffix 14) Warm Bronze (suffix 16)	<i>Fiberglass top finishes:</i> White (suffix W) <i>Glass top finishes:</i> Clear glass (suffix C) Etched glass (suffix E)
---	---	--





Construction

<i>Wood top finishes:</i> Teak (suffix K) <i>Maintenance:</i> See pages 28-29.	<i>Frame:</i> Frame is aluminum castings and extrusions welded together. Finished in highly durable weather resistant polyester powder coat paint. Y-shaped stainless steel connectors attach tops on corners. <i>Glass Top:</i> 3/8" beveled glass top available in clear or acid etched. <i>Porcelain Top:</i> .08" thick steel plate with a porcelain enamel layer comprised of glass particles, baked to melt into a .002" smooth surface. Honey comb subtop comprised of metal or particle wood board provides additional support.	<i>Teak:</i> 1" natural teak. <i>Fiberglass Top:</i> 1" thick fiberglass available in white finish. <i>Note:</i> Teak tops will patina over time if left outdoors and will turn a silvery grey color. <i>Glides:</i> Clear butyrate plastic.
---	--	---

Richard Schultz
1966 Collection® End and Coffee Tables

Designer(s):
Richard Schultz, 1966

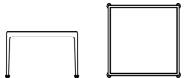

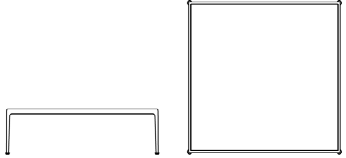
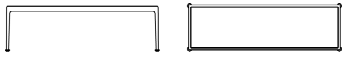
description	w	d	h	weight	top
1966-18L 1966 End Table 	18"	18"	15"	17 lbs.	Glass
	18"	18"	15"	16 lbs.	Porcelain
	18"	18"	15"	24 lbs.	Teak
	18"	18"	15"	17 lbs.	Fiberglass
1966-18LCOV 1966 End Table cover	—	—	—	—	—
1966-19L 1966 Coffee Table 	32"	20"	15"	28 lbs.	Glass
	32"	20"	15"	23 lbs.	Porcelain
	32"	20"	15"	27 lbs.	Teak
	32"	20"	15"	24 lbs.	Fiberglass
1966-19LCOV 1966 Coffee Table cover	—	—	—	—	—
1966-24L 1966 Coffee Table 	28"	28"	15"	34 lbs.	Glass
	28"	28"	15"	30 lbs.	Porcelain
	28"	28"	15"	28 lbs.	Teak
	28"	28"	15"	31 lbs.	Fiberglass
1966-24LCOV 1966 Coffee Table cover	—	—	—	—	—
1966-26L 1966 Coffee Table 	38"	38"	15"	57 lbs.	Glass
	38"	38"	15"	44 lbs.	Porcelain
	38"	38"	15"	44 lbs.	Teak
	38"	38"	15"	43 lbs.	Fiberglass
1966-26LCOV 1966 Coffee Table cover	—	—	—	—	—
1966-60L 1966 Coffee Table 	60"	60"	15"	138 lbs.	Glass
	60"	60"	15"	127 lbs.	Porcelain
	60"	60"	15"	108 lbs.	Teak
	60"	60"	15"	100 lbs.	Fiberglass
1966-60LCOV 1966 Coffee Table cover	—	—	—	—	—
1966-20L 1966 Coffee Table 	60"	18"	15"	44 lbs.	Glass
	60"	18"	15"	55 lbs.	Porcelain
	60"	18"	15"	47 lbs.	Teak
	60"	18"	15"	40 lbs.	Fiberglass
1966-20LCOV 1966 Coffee Table cover	—	—	—	—	—

pattern no.	
1966-18L-G-(-)(-)	\$1,760.
1966-18L-P-(-)(-)	2,005.
1966-18L-K-(-)	2,071.
1966-18L-F-(-)(-)	2,130.
1966-18LCOV	283.
1966-19L-G-(-)(-)	2,058.
1966-19L-P-(-)(-)	2,326.
1966-19L-K-(-)	2,459.
1966-19L-F-(-)(-)	2,577.
1966-19LCOV	461.
1966-24L-G-(-)(-)	2,029.
1966-24L-P-(-)(-)	2,685.
1966-24L-K-(-)	2,805.
1966-24L-F-(-)(-)	2,924.
1966-24LCOV	631.
1966-26L-G-(-)(-)	2,685.
1966-26L-P-(-)(-)	3,251.
1966-26L-K-(-)	3,759.
1966-26L-F-(-)(-)	4,057.
1966-26LCOV	641.
1966-60L-G-(-)(-)	4,833.
1966-60L-P-(-)(-)	5,727.
1966-60L-K-(-)	6,414.
1966-60L-F-(-)(-)	6,862.
1966-60LCOV	865.
1966-20L-G-(-)(-)	2,368.
1966-20L-P-(-)(-)	3,025.
1966-20L-K-(-)	3,145.
1966-20L-F-(-)(-)	3,264.
1966-20LCOV	657.

Order Code

Example:	1966-18L-G-E-S
1966-18L	18" x 18" end table
G	Glass top
E	Etched glass top
S	Weatherable Silver frame

Specify:

1. Pattern number
2. Top material
3. Top finish selection
4. Base finish selection

Ordering Information

Base finishes:

- Blue (suffix BLU)
- Chestnut (suffix N)
- Dark Bronze (suffix 14)
- Green (suffix 007)
- Light Bronze (suffix 13)
- Lime Green (suffix LGR)
- Onyx (suffix O)
- Orange (suffix ORG)
- Plum (suffix PLM)
- Sky Blue (suffix 3)
- Warm Bronze (suffix 16)
- Warm Wood (suffix 12)
- Weatherable Silver (suffix S)
- White (suffix W)
- Yellow (suffix YEL)

Porcelain top finishes:

- White (suffix W)
- Brown (suffix B)
- Marine Blue (suffix M)
- Warm Wood (suffix 12)
- Light Bronze (suffix 13)
- Dark Bronze (suffix 14)
- Warm Bronze (suffix 16)

Fiberglass top finishes:

- White (suffix W)
- Glass top finishes:
- Clear glass (suffix C)
- Etched glass (suffix E)

Construction

Wood top finishes:

- Teak (suffix K)

Maintenance:

See pages 28-29.

Frame:

Frame is aluminum castings and extrusions welded together. Finished in highly durable weather resistant polyester powder coat paint. Y-shaped stainless steel connectors attach tops on corners.

Glass Top:

3/8" beveled glass top available in clear or acid etched.

Porcelain Top:

.08" thick steel plate with a porcelain enamel layer comprised of glass particles, baked to melt into a .002" smooth surface. Honey comb subtop comprised of metal or particle wood board provides additional support.

Teak:

1" natural teak.

Fiberglass Top:

1" thick fiberglass available in white finish.





Note:

Teak tops will patina over time if left outdoors and will turn a silvery grey color.

Glides:

Clear butyrate plastic.

Richard Schultz
1966 Collection® End and Coffee Tables

	description	w	d	h	weight	top
<i>Designer(s):</i> Richard Schultz, 1966  	1966-28L 1966 Coffee Table 	60"	38"	15"	85 lbs.	Glass
		60"	38"	15"	87 lbs.	Porcelain
		60"	38"	15"	71 lbs.	Teak
		60"	38"	15"	65 lbs.	Fiberglass
	1966-28LCOV 1966 Coffee Table cover	–	–	–	–	–
	1966-90L 1966 Coffee Table 	90"	38"	15"	132 lbs.	Glass
90"		38"	15"	TBD lbs.	Porcelain	
90"		38"	15"	105 lbs.	Teak	
90"		38"	15"	100 lbs.	Fiberglass	
	1966-90LCOV 1966 Coffee Table cover	–	–	–	–	–

pattern no.	
1966-28L-G-(-)(-)	\$3,043.
1966-28L-P-(-)(-)	3,819.
1966-28L-K-(-)	4,595.
1966-28L-F-(-)(-)	4,833.
1966-28LCOV	828.
1966-90L-G-(-)(-)	4,534.
1966-90L-P-(-)(-)	5,455.
1966-90L-K-(-)	6,114.
1966-90L-F-(-)(-)	6,562.
1966-90LCOV	1,050.

Order Code

<i>Example:</i>	1966-18L-G-E-S
1966-18L	18" x 18" end table
G	Glass top
E	Etched glass top
S	Weatherable Silver frame

Specify:

1. Pattern number
2. Top material
3. Top finish selection
4. Base finish selection

Ordering Information

Base finishes:

Blue (suffix BLU)
Chestnut (suffix N)
Dark Bronze (suffix 14)
Green (suffix 007)
Light Bronze (suffix 13)
Lime Green (suffix LGR)
Onyx (suffix O)
Orange (suffix ORG)
Plum (suffix PLM)
Sky Blue (suffix 3)
Warm Bronze (suffix 16)
Warm Wood (suffix 12)
Weatherable Silver (suffix S)
White (suffix W)
Yellow (suffix YEL)

Porcelain top finishes:

White (suffix W)
Brown (suffix B)
Marine Blue (suffix M)
Warm Wood (suffix 12)
Light Bronze (suffix 13)
Dark Bronze (suffix 14)
Warm Bronze (suffix 16)

Fiberglass top finishes:

White (suffix W)

Glass top finishes:
Clear glass (suffix C)
Etched glass (suffix E)

Construction

Wood top finishes:

Teak (suffix K)

Maintenance:

See pages 28-29.

Frame:

Frame is aluminum castings and extrusions welded together. Finished in highly durable weather resistant polyester powder coat paint. Y-shaped stainless steel connectors attach tops on corners.

Glass Top:

3/8" beveled glass top available in clear or acid etched.

Porcelain Top:

.08" thick steel plate with a porcelain enamel layer comprised of glass particles, baked to melt into a .002" smooth surface. Honey comb subtop comprised of metal or particle wood board provides additional support.

Teak:

1" natural teak.

Fiberglass Top:

1" thick fiberglass available in white finish.

Note:

Teak tops will patina over time if left outdoors and will turn a silvery grey color.

Glides:

Clear butyrate plastic.

Richard Schultz
1966 Collection® Serving Cart

Designer(s):
Richard Schultz, 1966

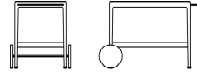

description	w	d	h	weight	top
1966-55 Serving cart 	23 1/2"	39"	26 1/4"	55 lbs.	Porcelain
	23 1/2"	39"	26 1/4"	61 lbs.	Teak
	23 1/2"	39"	26 1/4"	61 lbs.	Fiberglass
1966-55COV Serving cart cover					

pattern no.	
1966-55-P-(-)(-)	\$4,491.
1966-55-K-(-)	5,408.
1966-55-F-(-)(-)	5,630.
1966-55COV	750.

Order Code

<i>Example:</i> 1966-55-P-M-W	
1966-55	Serving Cart
P	Porcelain top
M	Marine Blue top
W	White frame

Specify:

1. Pattern number
2. Top material
3. Top finish selection
4. Base finish selection

Ordering Information

<i>Base finishes:</i>	<i>Porcelain top finishes:</i>	<i>Fiberglass top finishes:</i>
Blue (suffix BLU)	White (suffix W)	White (suffix W)
Chestnut (suffix N)	Brown (suffix B)	
Dark Bronze (suffix 14)	Marine Blue (suffix M)	
Green (suffix 007)	Warm Wood (suffix 12)	
Light Bronze (suffix 13)	Light Bronze (suffix 13)	
Lime Green (suffix LGR)	Dark Bronze (suffix 14)	
Onyx (suffix O)	Warm Bronze (suffix 16)	
Orange (suffix ORG)		
Plum (suffix PLM)		
Sky Blue (suffix 3)		
Warm Bronze (suffix 16)		
Warm Wood (suffix 12)		
Weatherable Silver (suffix S)		
White (suffix W)		
Yellow (suffix YEL)		

Construction

Wood top finishes:
Teak (suffix K)

Maintenance:
See pages 28-29.

Frame:
Frame is aluminum castings and extrusions welded together. Finished in highly durable weather resistant polyester powder coat paint. Y-shaped stainless steel connectors attach tops on corners. Wheels are cast aluminum with rubber tires and a differential axle.

Porcelain Top:
.08" thick steel plate with a porcelain enamel layer comprised of glass particles, baked to melt into a .002" smooth surface. Honey comb subtop comprised of metal or particle wood board provides additional support.

Teak:
1" natural teak.

Fiberglass Top:
1" thick fiberglass available in white finish.





Note:
Teak tops will patina over time if left outdoors and will turn a silvery grey color.

Glides:
Clear butyrate plastic.

Richard Schultz
Topiary® Dining Tables

Designer(s):
 Richard Schultz, 1996



description	w	d	h	weight	top
TOP-28 Topiary dining table base only	24"	24"	28"	45 lbs.	–
					
TH Umbrella support, powder coated, accepts 1 1/4" diameter umbrella shaft					
TI Umbrella weight				13 lbs.	
TG-30 Glass top	30"	30"		30 lbs.	tempered glass
					
TG-42 Glass top	42"	42"		66 lbs.	tempered glass
					
TG-56 Glass top	56"	56"		105 lbs.	tempered glass
					

pattern no.	
TOP-28-()	\$2,972.
TH-()	746.
TI	316.
TG-30	776.
TG-42	1,193.
TG-56	2,024.





Order Code	Ordering Information	Construction
<i>Example:</i> TOP-28-1	<i>Finishes:</i>	<i>Topiary frame:</i>
TOP-28 Dining table base	Blue (suffix BLU)	3/16" aluminum sheet stamped and formed. Stainless steel connectors and finished in highly durable weather resistant polyester powder coat paint.
1 Forest Green base	Chestnut (suffix N)	
	Choice White (suffix 6)	
	Daffodil Yellow (suffix 2)	
	Dark Bronze (suffix 14)	
	Forest Green (suffix 1)	
	Green (suffix 007)	
	Light Bronze (suffix 13)	
	Lime Green (suffix LGR)	
	Onyx (suffix 0)	
	Orange (suffix ORG)	
	Plum (suffix PLM)	
	Sky Blue (suffix 3)	
	Terra Cotta (suffix 5)	
	Warm Bronze (suffix 16)	
	Warm Wood (suffix 12)	
	Weatherable Silver (suffix S)	
	White (suffix W)	
	Yellow (suffix YEL)	
<i>Specify:</i>		<i>Glass Top:</i>
1. Pattern number		3/8" beveled clear glass top.
2. Base finish selection		

Shelton Mindel

SM Tables

Designer(s):
Peter Shelton and Lee Mindel,
2006



description	w	d	h
SM9 Shelton Mindel side table 	24"	24"	18"
SM91 Shelton Mindel small coffee table 	42"	24"	14"
SM92 Shelton Mindel large coffee table 	48"	30"	14"
SM93 Shelton Mindel square coffee table 	40"	40"	14"

pattern no.	white/ clear glass	white/ painted glass	white/ slate	stainless/ clear glass	stainless/ painted glass	stainless/ slate
SM9-(-)(-)	\$3,795.	\$4,119.	\$6,767.	\$4,184.	\$4,507.	\$7,152.
SM91-(-)(-)	3,818.	4,386.	7,867.	4,343.	4,913.	8,392.
SM92-(-)(-)	4,243.	4,949.	8,896.	4,611.	5,318.	9,264.
SM93-(-)(-)	6,931.	7,775.	9,978.	7,607.	8,534.	10,655.

Order Code

<i>Example:</i> SM93-2-S2	
SM93	Shelton Mindel square coffee table
2	White
S2	Painted White Starphire

Note:
The SM tables are part of a collection. Please refer to SM side chair on page 272 and SM1 and SM2 lounge collection on pages 274 and 276.

Ordering Information

Specify:

1. Pattern number
2. Base option
3. Top option

Shipping:

Top and base of SM tables will ship in separate packages.

Glass top finishes:

Clear glass (suffix G2)
Painted White Starphire (suffix S2)

Slate top finish:

Natural black (suffix SN)

Base finishes:

White (suffix 2)
Stainless Steel (suffix S)

Maintenance:

See pages 27-28.

Note:

The SM Table Collection is Greenguard certified.

For weight information, please contact your KnollStudio representative.

Construction

Frame:





Constructed of seamless stainless steel, frame has continuous appearance. White bases are coated in a tough, abrasion-resistant Rilsan finish. Polished bases are stainless steel, hand buffed to a mirror finish. Tops rest on four transparent silicon spacers.

Top:

Three top options: 3/8" thick clear glass with a 1/8" wide bevel, top and edges have a slight green tint; 3/4" thick Starphire™ glass with a bevel edge, underside of glass is painted white; 3/8" thick natural cleft slate with beveled edge.

Glides:

Glides are included with the table base.

	description	w	d	h
<p><i>Designer(s):</i> Daniel Stromborg, 2012</p> <p><i>Award(s):</i> Best of NeoCon Silver Award 2012</p> 	<p>DS02 Round table</p> 	32"	32"	29"
	<p>DS04 Round table</p> 	36"	36"	29"
	<p>DS06 Round table</p> 	42"	42"	29"

pattern no.	laminate	glass (G2)	GCO	engineered stone (VB)
DS02-(-)-(-)-(-)	\$1,597.	\$1,982.	\$3,043.	\$3,235.
DS04-(-)-(-)-(-)	1,764.	2,295.	3,403.	3,630.
DS06-(-)-(-)-(-)	2,045.	2,826.	4,422.	4,656.

Order Code	Ordering Information	Construction
<p><i>Example:</i> DS02-118-WHT-YEL</p> <p>DS02 32" Round table</p> <p>118 Bright White laminate top</p> <p>WHT White leg finish</p> <p>YEL Yellow rail finish</p>	<p><i>Leg paint finishes:</i> White (suffix WHT) Dark Charcoal (suffix CHR)</p> <p><i>Rail paint finishes:</i> White (suffix WHT) Grey (suffix GRY) Dark Charcoal (suffix CHR) Yellow (suffix YEL) Lime Green (suffix LGR) Orange (suffix ORG) Plum (suffix PLM) Sky Blue (suffix SBL) Blue (suffix BLU)</p>	<p><i>Top Finishes:</i> White (suffix WHT) Bright White (suffix O118)</p> <p><i>Laminate, outdoor:</i> Bright White (suffix O118)</p> <p><i>Glass:</i> Clear Glass (suffix G2)</p> <p><i>Natural Marble:</i> Cararra, honed (suffix GCO)</p> <p><i>Engineered Stone:</i> Vetro Bianco (suffix VB)</p> <p><i>Note:</i> All finishes and surfaces are suitable for outdoor use.</p> <p><i>Maintenance:</i> See pages 28-29.</p>
<p><i>Specify:</i> 1. Pattern number 2. Top finish 3. Leg finish 4. Rail finish</p>		<p><i>Frame:</i> Frames are constructed from extruded aluminum rails, which are connected using die-cast aluminum 'X' and 'Y' shaped castings. Structural steel legs join the table's extruded aluminum rails through a blind assembly, seamlessly tying the leg to the cope detailed rail. Stainless steel hardware and fasteners are used throughout the table's construction.</p> <p>All painted parts are finished in ultra-durable outdoor polyester powder coat finish. Steel legs are pre-treated with a zinc-rich epoxy primer that provides a robust base of protection from the elements.</p> <p>Tops are elevated off the table's base using cast aluminum (glass) or nylon spacers (laminate, marble, or engineered stone). All tops are secured to the base using threaded metal inserts and fasteners. For glass tops, the plated brushed aluminum spacer acts as a glass bolt and is attached to the glass using an ultra-strong adhesive.</p>

<p><i>Outdoor Laminate:</i> White laminate faces with black phenolic core. Core is constructed of FSC certified craft paper and phenolic resin.</p> <p><i>Glass:</i> 1/2" thick clear tempered glass.</p> <p><i>Marble:</i> Honed natural Cararra marble.</p> <p><i>Note:</i> Marble is treated to resist stains with a topical sealer, which requires maintenance. Natural marbles will develop a rich patina when used outdoors. Natural finished marbles will contain open fissures and pin-holes, which is considered a natural desirable trait.</p> <p><i>Engineered Stone:</i> Polished, bright white surface is nonporous and more compact than most granites. Comprised of 93% fused quartz. It does not yellow or stain and is scratch resistant. Suitable for outdoors.</p> <p><i>Glides:</i> Non-marking indoor/outdoor grey nylon glide protects the table and the floor. An adjustable height indoor glide kit is also included.</p>

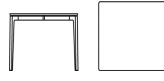
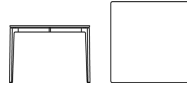
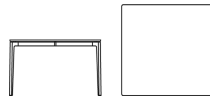
	description	w	d	h	
<p><i>Designer(s):</i> Daniel Stromborg, 2012</p> <p><i>Award(s):</i> Best of NeoCon Silver Award 2012</p> 	DS08 Square table	36"	36"	29"	
		DS10 Square table	42"	42"	29"
		DS12 Square table	48"	48"	29"
					

pattern no.	laminate	G2	GCO	engineered stone (VB)
DS08-(-)(-)(-)	\$1,805.	\$2,243.	\$3,458.	\$3,636.
DS10-(-)(-)(-)	2,097.	2,620.	3,873.	4,143.
DS12-(-)(-)(-)	2,425.	3,215.	4,340.	4,629.

Order Code	Ordering Information	Construction
<i>Example:</i> DS08-NGC-CHR-PLM	<i>Leg paint finishes:</i> White (suffix WHT) Dark Charcoal (suffix CHR)	<i>Top Finishes:</i> <i>Laminate, outdoor:</i> Bright White (suffix O118)
DS08 36" square table	<i>Rail paint finishes:</i> White (suffix WHT) Grey (suffix GRY) Dark Charcoal (suffix CHR) Yellow (suffix YEL) Lime Green (suffix LGR) Orange (suffix ORG) Plum (suffix PLM) Sky Blue (suffix SBL) Blue (suffix BLU)	<i>Glass:</i> Clear Glass (suffix G2)
NGC Cararra marble top		<i>Natural Marble:</i> Cararra, honed (suffix GCO)
CHR Dark Charcoal leg finish		<i>Engineered Stone:</i> Vetro Bianco (suffix VB)
PLM Plum rail finish		<i>Note:</i> All finishes and surfaces are suitable for outdoor use.
<i>Specify:</i> 1. Pattern number 2. Top finish 3. Leg finish 4. Rail finish		<i>Maintenance:</i> See pages 28-29.
		<i>Frame:</i> Frames are constructed from extruded aluminum rails, which are connected using die-cast aluminum 'X' and 'Y' shaped castings. Structural steel legs join the table's extruded aluminum rails through a blind assembly, seamlessly tying the leg to the cope detailed rail. Stainless steel hardware and fasteners are used throughout the table's construction.
		All painted parts are finished in ultra-durable outdoor polyester powder coat finish. Steel legs are pre-treated with a zinc-rich epoxy primer that provides a robust base of protection from the elements.
		Tops are elevated off the table's base using cast aluminum (glass) or nylon spacers (laminate, marble, or engineered stone). All tops are secured to the base using threaded metal inserts and fasteners. For glass tops, the plated brushed aluminum spacer acts as a glass bolt and is attached to the glass using an ultra-strong adhesive.

Outdoor Laminate:
White laminate faces with black phenolic core. Core is constructed of FSC certified craft paper and phenolic resin.

Glass:
1/2" thick clear tempered glass.

Marble:
Honed natural Cararra marble.

Note:
Marble is treated to resist stains with a topical sealer, which requires maintenance. Natural marbles will develop a rich patina when used outdoors. Natural finished marbles will contain open fissures and pin-holes, which is considered a natural desirable trait.

Engineered Stone:
Polished, bright white surface is nonporous and more compact than most granites. Comprised of 93% fused quartz. It does not yellow or stain and is scratch resistant. Suitable for outdoors.

Glides:
Non-marking indoor/outdoor grey nylon glide protects the table and the floor. An adjustable height indoor glide kit is also included.

Daniel Stromborg

Rectangular Tables

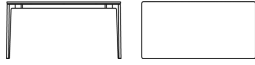
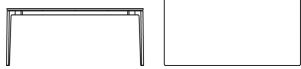
	description	w	d	h
<p><i>Designer(s):</i> Daniel Stromborg, 2012</p> <p><i>Award(s):</i> Best of NeoCon Silver Award 2012</p> 	<p>DS14 Rectangular table</p> 	60"	30"	29"
	<p>DS16 Rectangular table</p> 	72"	36"	29"

pattern no.	laminate	G2	GCO	engineered stone (VB)
DS14-(-)(-)(-)	\$2,177.	\$2,863.	\$4,000.	\$4,245.
DS16-(-)(-)(-)	2,653.	3,620.	4,775.	5,029.

Order Code	Ordering Information	Construction
<p><i>Example:</i> DS14-G2-WHT-BLU</p> <p>DS14 60" x 30" rectangular table</p> <p>G2 Clear glass top</p> <p>WHT White leg finish</p> <p>BLU Blue rail finish</p> <p><i>Specify:</i></p> <ol style="list-style-type: none"> 1. Pattern number 2. Top finish 3. Leg finish 4. Rail finish 	<p><i>Leg paint finishes:</i></p> <p>White (suffix WHT)</p> <p>Dark Charcoal (suffix CHR)</p> <p><i>Rail paint finishes:</i></p> <p>White (suffix WHT)</p> <p>Grey (suffix GRY)</p> <p>Dark Charcoal (suffix CHR)</p> <p>Yellow (suffix YEL)</p> <p>Lime Green (suffix LGR)</p> <p>Orange (suffix ORG)</p> <p>Plum (suffix PLM)</p> <p>Sky Blue (suffix SBL)</p> <p>Blue (suffix BLU)</p>	<p>Top Finishes:</p> <p><i>Laminate, outdoor:</i></p> <p>Bright White (suffix O118)</p> <p><i>Glass:</i></p> <p>Clear Glass (suffix G2)</p> <p><i>Natural Marble:</i></p> <p>Cararra, honed (suffix GCO)</p> <p><i>Engineered Stone:</i></p> <p>Vetro Bianco (suffix VB)</p> <p><i>Note:</i></p> <p>All finishes and surfaces are suitable for outdoor use.</p> <p><i>Maintenance:</i></p> <p>See pages 28-29.</p> <p><i>Frame:</i></p> <p>Frames are constructed from extruded aluminum rails, which are connected using die-cast aluminum 'X' and 'Y' shaped castings. Structural steel legs join the table's extruded aluminum rails through a blind assembly, seamlessly tying the leg to the cope detailed rail. Stainless steel hardware and fasteners are used throughout the table's construction.</p> <p>All painted parts are finished in ultra-durable outdoor polyester powder coat finish. Steel legs are pre-treated with a zinc-rich epoxy primer that provides a robust base of protection from the elements.</p> <p>Tops are elevated off the table's base using cast aluminum (glass) or nylon spacers (laminate, marble, or engineered stone). All tops are secured to the base using threaded metal inserts and fasteners. For glass tops, the plated brushed aluminum spacer acts as a glass bolt and is attached to the glass using an ultra-strong adhesive.</p>

Outdoor Laminate:

White laminate faces with black phenolic core. Core is constructed of FSC certified craft paper and phenolic resin.

Glass:

1/2" thick clear tempered glass.

Marble:

Honed natural Cararra marble.

Note:











Marble is treated to resist stains with a topical sealer, which requires maintenance. Natural marbles will develop a rich patina when used outdoors. Natural finished marbles will contain open fissures and pin-holes, which is considered a natural desirable trait.

Engineered Stone:

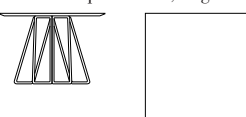
Polished, bright white surface is nonporous and more compact than most granites. Comprised of 93% fused quartz. It does not yellow or stain and is scratch resistant. Suitable for outdoors.

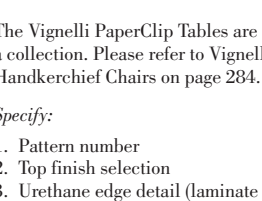
Glides:

Non-marking indoor/outdoor grey nylon glide protects the table and the floor. An adjustable height indoor glide kit is also included.

	description	w	d	h	weight	top
Designer(s): Vignelli Design, 1994 	49TS-30 Square table, small 	30"	30"	28 1/8"	37 lbs.	Laminate
		30"	30"	28 1/8"	51 lbs.	Clear glass
		30"	30"	28 1/8"	51 lbs.	White glass
		30"	30"	28 1/8"	72 lbs.	Slate
	49TS-36 Square table, medium 	36"	36"	28 1/8"	55 lbs.	Laminate
		36"	36"	28 1/8"	75 lbs.	Clear glass
		36"	36"	28 1/8"	75 lbs.	White glass
		36"	36"	28 1/8"	105 lbs.	Slate
	49TS-42 Square table, large 	42"	42"	28 1/8"	75 lbs.	Laminate
		42"	42"	28 1/8"	103 lbs.	Clear glass
		42"	42"	28 1/8"	103 lbs.	White glass
		42"	42"	28 1/8"	144 lbs.	Slate
	49TR-36 Round table, small 	36"		28 1/8"	41 lbs.	Laminate
		36"		28 1/8"	57 lbs.	Clear glass
		36"		28 1/8"	57 lbs.	White glass
		36"		28 1/8"	80 lbs.	Slate
	49TR-42 Round table, medium 	42"		28 1/8"	58 lbs.	Laminate
		42"		28 1/8"	80 lbs.	Clear glass
		42"		28 1/8"	80 lbs.	White glass
		42"		28 1/8"	112 lbs.	Slate
	49TR-48 Round table, large 	48"		28 1/8"	76 lbs.	Laminate
		48"		28 1/8"	106 lbs.	Clear glass
		48"		28 1/8"	106 lbs.	White glass
		48"		28 1/8"	147 lbs.	Slate

pattern no.	Painted/ black base	Pol. chrome base
49TS-30-()-()-()	\$2,126.	\$2,362.
49TS-30-G2-()	2,362.	2,600.
49TS-30-G3-()	2,599.	2,835.
49TS-30-SN-()	5,438.	5,674.
49TS-36-()-()-()	2,362.	2,716.
49TS-36-G2-()	2,839.	3,192.
49TS-36-G3-()	3,142.	3,495.
49TS-36-SN-()	6,457.	6,810.
49TS-42-()-()-()	2,599.	3,075.
49TS-42-G2-()	3,311.	3,787.
49TS-42-G3-()	3,667.	4,142.
49TS-42-SN-()	7,958.	8,436.
49TR-36-()-()-()	2,126.	2,362.
49TR-36-G2-()	3,075.	3,312.
49TR-36-G3-()	3,311.	3,546.
49TR-36-SN-()	6,637.	6,872.
49TR-42-()-()-()	2,362.	2,716.
49TR-42-G2-()	3,431.	3,785.
49TR-42-G3-()	3,740.	4,091.
49TR-42-SN-()	8,316.	8,669.
49TR-48-()-()-()	2,599.	3,075.
49TR-48-G2-()	3,903.	4,380.
49TR-48-G3-()	4,378.	4,854.
49TR-48-SN-()	9,520.	9,995.

Order Code

<i>Example:</i>	49TS-30-SN-1
49TS-30	PaperClip table, square, 30"
SN	Natural Black slate
1	Black

Ordering Information

Laminate top finishes:
Bright White (suffix 118)
Light Grey (suffix L)
Fog (suffix 128)
Jet Black (suffix 111)

Urethane edge finishes:
Light Grey (suffix LG)
Medium Grey (suffix MG)
Black (suffix BL)

Glass top finishes:
Clear (suffix G2)
White (suffix G3)

Slate top finish:
Natural Black (suffix SN)

Outdoor Powder Coat Finish:
Black (suffix 1)

Chrome base finish:
Polished Chrome (suffix C)

Maintenance:
See pages 28-29.

Note:
The PaperClip Table is Greenguard certified.

Construction

Top:
Three top options: 1" thick laminate top with molded urethane beveled edge; 1/2" thick clear tempered glass with polished pencil edge; and 3/4" thick natural cleft slate with beveled edge.

Base:
7/16" diameter cold rolled steel rod with fused polyester, outdoor powder coat and chrome-plated finishes.

Glides:
Plastic.

Outdoor use:
With proper preventative maintenance and limited exposure to the elements, the PaperClip cafe table is appropriate for outdoor environments. Specify outdoor powder coat black (suffix 1) base finish and clear glass (suffix G2) or slate (suffix SN) tops.

Shipping:
All tables shipped knocked-down. Base and top assembly required.

Laminate/slate edge detail:

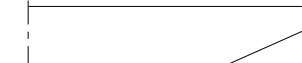

Glass edge detail:

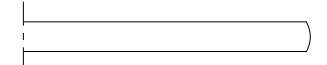

The Vignelli PaperClip Tables are part of a collection. Please refer to Vignelli Handkerchief Chairs on page 284.

Specify:

1. Pattern number
2. Top finish selection
3. Urethane edge detail (laminate tops only)
4. Leg finish selection

<i>pattern no.</i>	<i>page</i>	<i>pattern no.</i>	<i>page</i>	<i>pattern no.</i>	<i>page</i>	<i>pattern no.</i>	<i>page</i>
04CTR	330	173TR	366, 380	1966-255R	264	1966-46H	260
1050C	212	174TO	372, 380	1966-255RCOV	264	1966-46HCOV	260
1050C-1	212	175TO	372	1966-25COV	264	1966-55COV	394
1050C-2	212	175TO-F2	372	1966-25P	264	1966-55-F	394
1050C-3	212	176TR	368	1966-25R	264	1966-55-K	394
1051C	210	1966-18LCOV	390	1966-25RCOV	264	1966-55-P	394
1051C-S	206	1966-18L-F	390	1966-26BCOV	388	1966-60BCOV	388
1051C-ST	206	1966-18L-G	390	1966-26B-F	388	1966-60B-F	388
1052C	210	1966-18L-K	390	1966-26B-G	388	1966-60B-G	388
1052C-S	208	1966-18L-P	390	1966-26B-K	388	1966-60B-K	388
1053C	210	1966-19LCOV	390	1966-26B-P	388	1966-60B-P	388
1053C-S	208	1966-19L-F	390	1966-26CCOV	386	1966-60CCOV	386
1059C	210	1966-19L-G	390	1966-26C-F	386	1966-60C-F	386
1059C-S	208	1966-19L-K	390	1966-26C-G	386	1966-60C-G	386
108	308	1966-19L-P	390	1966-26C-K	386	1966-60C-K	386
108-KC-111	308	1966-20BCOV	388	1966-26C-P	386	1966-60C-P	386
1205-CO-S1	134	1966-20B-F	388	1966-26HCOV	384	1966-60HCOV	384
1205-CO-S2	134	1966-20B-G	388	1966-26H-F	384	1966-60H-F	384
1205-CO-S3	134	1966-20B-K	388	1966-26H-G	384	1966-60H-G	384
1205-C-S1	134	1966-20B-P	388	1966-26H-K	384	1966-60H-K	384
1205-C-S2	134	1966-20CCOV	386	1966-26H-P	384	1966-60H-P	384
1205-C-S3	134	1966-20C-F	386	1966-26LCOV	390	1966-60LCOV	390
1206-C-S1	136	1966-20C-G	386	1966-26L-F	390	1966-60L-F	390
1206-C-S2	136	1966-20C-K	386	1966-26L-G	390	1966-60L-G	390
1206-C-S3	136	1966-20C-P	386	1966-26L-K	390	1966-60L-K	390
1250BUTTON	218	1966-20HCOV	384	1966-26L-P	390	1966-60L-P	390
1250COVER	218	1966-20H-F	384	1966-28BCOV	388	1966-90HCOV	384
12A	218	1966-20H-G	384	1966-28B-F	388	1966-90H-F	384
12C	218	1966-20H-K	384	1966-28B-G	388	1966-90H-G	384
150AS	242	1966-20H-P	384	1966-28B-K	388	1966-90H-K	384
150AX	242	1966-20LCOV	390	1966-28B-P	388	1966-90H-P	384
150K	242	1966-20L-F	390	1966-28CCOV	386	1966-90LCOV	392
151CS	242	1966-20L-G	390	1966-28C-F	386	1966-90L-F	392
151CX	242	1966-20L-K	390	1966-28C-G	386	1966-90L-G	392
151K	242	1966-20L-P	390	1966-28C-K	386	1966-90L-K	392
153YS	242	1966-24BCOV	388	1966-28C-P	386	1966-90L-P	392
160TR	374	1966-24B-F	388	1966-28HCOV	384	2160-C	106
161TO	378	1966-24B-G	388	1966-28H-F	384	2160R	110
162TO	378	1966-24B-K	388	1966-28H-G	384	2160RS	110
162TR	374, 380	1966-24B-P	388	1966-28H-K	384	2160S-C	106
163TR	374, 376	1966-24CCOV	386	1966-28H-P	384	2161-C	108
164TR	368	1966-24C-F	386	1966-28LCOV	392	2161P	108
164TR-F2	368	1966-24C-G	386	1966-28L-F	392	2161S-C	108
164TR-VB	368	1966-24C-K	386	1966-28L-G	392	2162P	112
164TR-VBO	380	1966-24C-P	386	1966-28L-K	392	2162R	112
165TR	370	1966-24HCOV	384	1966-28L-P	392	2162RS	112
165TR-F2	370	1966-24H-F	384	1966-355	264	2163-C	108
165TR-VB	370	1966-24H-G	384	1966-355COV	264	2163R	112
169TR	376, 380	1966-24H-K	384	1966-41	266	2163RS	112
1705L-N	216	1966-24H-P	384	1966-41COV	266	2163S-C	108
1709Y-N	216	1966-24LCOV	390	1966-41P	266	2165	114
1715L-BRM	214	1966-24L-F	390	1966-42	266	23A	140
1715L-GLD	214	1966-24L-G	390	1966-42COV	266	23AK-N	140
1715L-N	214	1966-24L-K	390	1966-42P	266	23C	140
1719Y-BRM	214	1966-24L-P	390	1966-45H	260	23CH	140
1719Y-GLD	214	1966-25	264	1966-45HCOV	260	23CK-N	140
1719Y-N	214	1966-250	264	1966-45P	260, 262	23DOLLY	140
1725A-BRM	214	1966-250COV	264	1966-46B	262	23GA	140
1725A-GLD	214	1966-250P	264	1966-46BCOV	262	23TR24	354
1725A-N	214	1966-255	264	1966-46C	262	23TR27	354
172TR	366, 380	1966-255COV	264	1966-46CCOV	262	23TR36	354

<i>pattern no.</i>	<i>page</i>	<i>pattern no.</i>	<i>page</i>	<i>pattern no.</i>	<i>page</i>	<i>pattern no.</i>	<i>page</i>
23TR42	354	256AKIT-L	190	41A-KC or		46C	166
23TRH24	354	256AS-L	190	41AW-KC	122	46C-U	166
23TRH27	354	256CC-RN	190	41AW-U	122	47TR15	342
23TS24	354	256CKIT-L	190	41AW-U-KC	122	47TR19	344
23TS30	354	256CS-L	190	41C	124	47TR22	344
23TSH24	354	256LACE-L	190	41C-KC or		47TR24	342
23TSH27	354	257C	186	41CW-KC	124	47TR26	342
241LS	188	258LS	192	41CW-U	124	47TR30	342
242LS	188	259TS-G	336	41CW-U-KC	124	47TR50	342
245A-C	182	27A	164	41R	122, 124	47TR72	342
245A-S	182	27AGA	164	420C	52	47TS15	340
245AT-C	182	27C	162	420C-CO-K	52	47TS20	340
245AT-S	182	27CGA	162	420C-CO-KP	52	47TS31	340
247LS	188	27DOLLY	162, 164	420C-CO-U	52	47TS48	340
2480	310	29C	204	420CT-K	54	47TS64	340
2480D	310	29K	204	420CT-KP	54	48A	224
2481D	310	29TR-23-DE	350	420CT-U	54	48R	224
2482	312	29TR-23-LM	350	420F	52, 54	4901	284
2482T	312	29TR-27-DE	350	420K	52, 54	4901K-N	284
2485D	318	29TR-27-LM	350	420KP	52, 54	4901K-S	284
248LS	188	29TR-35-DE	352	420N	60	4902	286
250LC	192	29TR-35-LM	352	420P	52, 54	4902K-N	286
250LC-S	192	29TR-43-DE	352	421F	62, 64	4902K-S	286
250LS	192	29TR-43-LM	352	421FS	62	49100D	284, 286
2510T	324	29TR-H-23-DE	350	421K	62, 64	49TR-36	406
2510()	324	29TR-H23-LM	350	421KS	62	49TR-36-G2	406
2510T()	324	29TS-27-DE	350	421L	62	49TR-36-G3	406
2511T	324	29TS-27-LM	350	421LCO-K	62	49TR-36-SN	406
2511()	324	29TS-35-DE	352	421LCO-U	62	49TR-42	406
2511T()	324	29TS-35-LM	352	421L-GLD-K	62	49TR-42-G2	406
2515T	326	3	244, 248	421LS-C-K	62	49TR-42-G3	406
2515()	326	311	348	421LS-C-U	62	49TR-42-SN	406
2515T()	326	311-F1	348	421LT-K	64	49TR-48	406
2517T	326	311-F2	348	421LT-U	64	49TR-48-G2	406
2517T()	326	311-RO	348	422F	62	49TR-48-G3	406
251YC	192	312	348	422L	62	49TR-48-SN	406
251YC-L80	192	312-F1	348	423F	66	49TS-30	406
251YC-S	192	312-F2	348	423L	66	49TS-30-G2	406
251YS	192	312-RO	348	424F	66	49TS-30-G3	406
252	336	3710T	356	424Y	66	49TS-30-SN	406
2520T-C	314	3712T	358	427C	58	49TS-36	406
2521T-C	314	3714T	358	427C-CO-K	58	49TS-36-G2	406
2521T-C-G2	314	3716T	356	427C-CO-KP	58	49TS-36-G3	406
2522T-C	314	37A	226	427C-CO-U	58	49TS-36-SN	406
2523T-C	316	37A-U	230	427F	58	49TS-42	406
2524T-C	316	37C	226	427K	58	49TS-42-G2	406
252C	336	37C-U	230	427KP	58	49TS-42-G3	406
252C-SFG	336	37R	226	427N	60	49TS-42-SN	406
252-SFG	336	37R-T	226	427P	58	4-C-LG-N	102
2530Y2C	134	38A	116	428C	56	4-C-LG-S	102
2530Y3C	134	38A-KC or		428C-CO-K	56	4-C-SD-N	100
2541M	320	38AW-KC	116	428C-CO-KP	56	4-C-SD-S	100
2542M	320	38AW-U	116	428C-CO-U	56	4DOLLY	100
2543M	322	38AW-U-KC	116	428F	56	4GA	100
2544M	322	38C	118	428K	56	4LGSEAT	102
2545M	320	38C-KC or		428KP	56	4SDSEAT	100
2546M	320	38CW-KC	118	428N	60	50A-5-B	94
2547M	322	38CW-U	120	428P	56	50A-5-BE	94
2548M	322	38CW-U-KC	120	429F	68	50A-7	94
2549M	322	38R	120	429K	68	50AR-5-B	94
255A-C	184	400K	70	429L	68	50AR-5-BE	94
255A-S	184	400Y	70	44A	228	50AR-7	94
255C-C	184	410K	70	44AU	232	50C-1-B	96
255C-S	184	410Y	70	44R	228	50C-1-BE	96
256AC-RN	190	410Y-SK	70	46A	166	50C-2	96
		41A	122	46A-U	166		

<i>pattern no.</i>	<i>page</i>	<i>pattern no.</i>	<i>page</i>	<i>pattern no.</i>	<i>page</i>	<i>pattern no.</i>	<i>page</i>
50CR-1-B	96	667Y-KIT	234	87CSB-K-N	176	AAR2	80
50CR-1-BE	96	667YS-HB	236	87CSB-K-S	178	AAR2 cushions	80
50CR-2	96	667YS-KIT	236	87Dolly	170, 174, 178	AAR2S	80
50CS	282	67	156	87-F1	348	AAR3	80
50KIT	282	67R	156	87-F2	348	AAR3 cushions	80
50KIT-L	282	67S	156	87GA	170, 174	AAR3S	80
50L	98	68	158	87-RO	348	AAR4	78
50LACE	282	68C	160	87TABLET	170, 174	AAR4 cushions	78
50T1	296	68R	158	91A-GC	126	AAR4S	78
50T2	296	69	158	91A-GC-K	126	AAR5	88
53D1	280	69R	158	91C-GC	126	AAR5 cushions	88
53D2	280	701T-MC	334	91C-GC-K	126	AAR5S	88
53D3	280	701T-MN	334	91K	126	AAR6	88
53S1	280	701T-MV	334	92C-GC	126	AAR6 cushions	88
53S2	280	70L	252	92C-GC-K	126	AAR6S	88
53S3	280	70LM	256	92K	126	AAR7	88
58A	104	70LS	258	93A-GC	128	AAR7 cushions	88
58A-R	104	71A	244	93A-GC-K	128	AAR7S	88
58C	104	71A-T5G	244	93K	128	AAR8	82
58C-R	104	71A-W	246	94K	128	AAR8 cushions	82
59Dolly	166	72C	248, 250	94L-GC	128	AAR8S	82
614TS-KC-KC	360	72C-T5G-H	248	94L-GC-K	128	AAR9	82
614TS-KE-D	360	72C-W	250	94LY-GC	128	AAR9 cushions	82
614TS-K-K	360, 364	73	160	94LY-GC-K	128	AAR9S	82
614TS-LWT-LWT	360	73L	254	94YK	128	BO10C-AE	50
618TR-KC-KC	360	73R	160	95T-36-G2-GC	306	BO10C-AP	50
618TR-KE-D	360	74Y	252	95T-36-W-GC	306	BO10CO	50
618TR-K-K	360, 364	74YM	256	95T-40-G2-GC	306	BO10CO-K	50
618TR-LWT-LWT	360	75	328	95T-40-W-GC	306	BO11C	50
6242	300	751	194	AAC1	72	BO11C-AE	50
6248	300	751LT	194	AAC1 cushions	72	BO11C-AP	50
6254	300	752	194	AAC1S	72	BO11C-K	50
6260	302	752LT	194	AAC2	74	BO15L	38
6272	302	753	196	AAC2 cushions	74	BO15R	38
6348	298	753LT	196	AAC2S	74	BO2	38
6354	298	754	196	AAC3	74	BO21T-AE	294
6360	298	754LT	196	AAC3 cushions	74	BO21T-K	294
642TR-KC-KC	360	755	198	AAC3S	74	BO3	38
642TR-KE-D	360	755LT	198	AAC4	72	BO30-AL-3	46
642TR-LWT-LWT	360	756	198	AAC4 cushions	72	BO30-AL-P	46
643TA-KC-KC	360	756LT	198	AAC4S	72	BO30-AU-3	46
643TA-KE-D	360	759	338	AAC5	76	BO30-AU-P	46
643TA-LWT-LWT	360	760	338	AAC5 cushions	76	BO30-C-3	46
643TAS-HB-HL	362	790	222	AAC5S	76	BO30-C-P	46
6472	304	80D	292	AAC6	76	BO31-AL-3	48
6484	304	83ANCHOR	154	AAC6 cushions	76	BO31-AL-P	48
6496	304	83Y-K	152	AAC6S	76	BO31-AU-3	48
654LA	238	83YM	152	AAC7	76	BO31-AU-P	48
654LC	238	83YMW	152	AAC7 cushions	76	BO31-C-3	48
654LC-K	240	84Y-K	152	AAC7S	76	BO31-C-P	48
654L-KIT	238, 240	84YM	152	AAR1	78	BO4	38
655LO	238	84YMW	152	AAR1 cushions	78	BO5L	38
655LO-K	240	85T32M	154	AAR10	84	BO5R	38
655LO-KIT	238, 240	87	348	AAR10 cushions	84	BO6	40
657	220	87A	168	AAR10S	84	BO7	40
666C	234	87A-K-N	168	AAR11	84	BO8P	44
666C-KIT	234	87A-K-S	170	AAR11 cushions	84	BO9P	44
666CS-HB	236	87AS	180	AAR11S	84	BOC1	42
666CS-KIT	236	87C	172	AAR12L	86	BOC2	42
666CS-WB-HB	236	87CH	180	AAR12L cushions	86	C	298, 300, 302, 304
666CS-WB-KIT	236	87C-K-N	172	AAR12LS	86	CB1-C	90
666C-WB	234	87C-K-S	174	AAR12R	86	CB1-L	90
666C-WB-K	240	87CM	180	AAR12R cushions	86	CB2-C	90
666C-WB-KIT	234, 240	87CS	180	AAR12RS	86	CB2-L	90
667Y	234	87CSB	176	AAR1S	78	CB3	90

<i>pattern no.</i>	<i>page</i>	<i>pattern no.</i>	<i>page</i>
CBP1	92	SM1-1	274
CBP2	92	SM1-2	274
CX	298, 300, 302, 304	SM1-3	274
DS02	400	SM2-1	276
DS04	400	SM2-2	278
DS06	400	SM2-3	278
DS08	402	SM2S-1	276
DS10	402	SM2S-2	278
DS12	402	SM2S-3	278
DS14	404	SM8A	272
DS16	404	SM8A-U	272
G	182, 184, 284	SM8R	272
G [4902]	286	SM9	398
GL	298, 300, 302, 304	SM91	398
H	208	SM92	398
JL1-P	130	SM93	398
JL1-PLT	130	SWELL-20P	268
JL1-W	132	SWELL-31	268
JL1-WLT	132	SWELL-31COV	268
JL2-P	130	SWELL-31P	268
JL2-PLT	130	SWELL-32	268
JL2-W	132	SWELL-32COV	268
JL2-WLT	132	SWELL-33	268
JL3-P	130	SWELL-33COV	268
JL3-PLT	130	T	226
JL3-W	132	TBP	270
JL3-WLT	132	TDCP	270
KSP1	138	TG-30	396
KSP1S	138	TG-42	396
KSP2	138	TG-56	396
KSP2S	138	TH	396
KSP3	138	TI	396
KSP3S	138	TLCP	270
L	166	TOP-15	270
MK01A	142	TOP-25	270
MK01AU	144	TOP-250	270
MK01C	146	TOP-250COV	270
MK01CU	148	TOP-25COV	270
MK01R	142, 144, 146, 148	TOP-28	396
MK01RCN	142, 144, 146, 148	TOP-45	270
MK02A	150	TOP-455	270
MK02C	150	TOP-455COV	270
MK02R	150	TOP-45COV	270
MK02RCN	150	TR	162
MK11	332	TSC	270
MK12	332	TSCOV	270
MK13	332	TSCOV4	270
MK14	332	TSOP	270
MK15	332	upchg, welt	130, 132, 194, 196, 198, 244, 246
MK16	332	upchg, cushions	106, 108, 110, 112, 276
N10	346	upchg, cushionsS	278
N19-AW	200	upchg, cushionsSO	278
N20-DF	346	WC1T	288
OAC1	202	WC2T	288
P	182, 184	WL21F	34
P320COV	382	WL21S	34
P320-K	382	WL23	34
P320-W	382	WL25T	290
P321COV	382	WS1CA	36
P321-K	382	WS1CA-CC	36
P321-W	382	WS1CA-NCU	36
P322COV	382	WS1CA-NO	36
P322-K	382	WS2CN	36
P322-W	382		
R	218, 244, 248		

Selling Policy

	<p>This Selling Policy supercedes all previous selling policies. Prices, discounts and product offerings are subject to change without notice.</p>
Terms & Conditions of Sales	<p>Sales by Knoll, Inc. or Knoll North America Corp. ("Seller") of Knoll Product Lines (hereinafter "Products") within the United States and Canada are made only on the terms which are contained in this Selling Policy. Seller hereby gives notice of its objection to any different or additional terms and conditions. This sale is expressly conditional upon Purchaser's assent to the terms and conditions set forth below. Additional terms and conditions may apply to KnollStudio and KnollTextiles orders. These terms and conditions may be modified or supplemented only by a written document signed by an authorized representative of Seller. These terms and conditions supercede any prior and/or contemporaneous agreements or correspondence between Purchaser and Seller. Written quotations expire thirty (30) days from the date of issuance and can be withdrawn by written notice anytime during that period. Where Purchaser and Seller have entered into the Knoll Electronic Terms and Conditions, all orders, acknowledgements, invoices and other business communications placed or transmitted in accordance with the Knoll Electronic Terms and Conditions shall be deemed to be in writing and signed and shall be valid for all purposes as if they were originated and maintained in documentary form.</p>
Ordering Information	<p>All orders must be in writing. The product pattern number(s) contained on Seller's order acknowledgement shall be the final expression of the order.</p>
Order Confirmation	<p>A purchase order is not binding on Seller until Purchaser has received Seller's order confirmation or acknowledgment.</p>
Pricing Policies	<p>List prices are subject to change without notice.</p> <p>List prices shall be those prices in effect on the date of receipt of a complete purchase order unless shipment is requested more than ninety (90) days after order entry in which case prices in effect on the date of shipment apply. List prices include specified freight costs. Unless specified in writing by Seller, no other charges are included in Seller's list prices.</p>
Taxes	<p>All sales, use, excise and other taxes applicable to the sale of the Products shall be paid by Purchaser. If Purchaser claims an exemption from any tax, Purchaser shall submit to Seller the appropriate exemption certificates.</p>
Terms of Payment	<p>Payment for one hundred percent (100%) of the net order amount is due within thirty (30) days of the date of invoice, which is generally issued upon shipment. In case of any discrepancies, such as shortages, and Seller is notified in writing within ten (10) days of receipt of Product, only that portion may be deducted and the balance paid. For orders greater than \$100,000 net, a fifty percent (50%) deposit is due at the time of order placement, with the remainder due within thirty (30) days of the date of invoice.</p> <p>KnollStudio orders less than \$2,000 require payment for one hundred percent (100%) of the net order amount (including any applicable sales tax and charges for inside delivery, special packaging, etc.), due at time of order placement. For KnollStudio orders greater than \$2,000, a one-half (50%) deposit is due at time of order placement with the remainder (including any applicable sales tax and charges for inside delivery, special packaging, etc.) due prior to shipment.</p> <p>If, in the judgment of Seller, Purchaser's financial condition does not justify the terms of the payment, Seller may require full or partial payment in advance.</p> <p>Past due accounts shall be charged one and one-half percent (1.5%) per month, or the highest rate permitted by law, whichever is less, and will be added to the outstanding balance. In the event Purchaser defaults on payment, Purchaser shall be liable for all collection costs, including reasonable attorney's fees and costs.</p>
Changes and Cancellation	<p>Purchase orders may not be changed or cancelled, in whole or in part, without prior written consent of Seller. Changes may effect delivery dates. Expenses incurred because of changes shall be charged to Purchaser. In the event of cancellations, Purchaser will be liable for reasonable cancellation charges established by Seller. Orders for special Product, orders including "COM" (hereinafter defined) material and orders pursuant to expedited delivery programs, may not be canceled.</p>
Freight Prepaid	<p>Freight is prepaid and included in the price of all Products, except KnollTextiles, within the 48 contiguous United States for orders placed with Knoll, Inc. and within Canada, excluding the Yukon, Northwest Territories, Nunavut and Newfoundland for orders placed with Knoll North America Corp. Packing is tested for rigorous motion and transportation but is not guaranteed to protect furniture from all conditions. If special packaging is required for any reason, please consult with your sales representative or dealer. Seller shall select the method of shipment and routing. Freight for all KnollTextiles orders is prepaid and added to the invoice.</p>
Delivery/Freight Charges	<p>Shipments outside the contiguous 48 United States and Canada shall be shipped F.O.B. Origin.</p> <p>For shipments outside the contiguous United States and Canada, Purchaser is responsible for the cost of freight from point of embarkation, including any handling and transportation charges incidental to loading at the point of departure and unloading at the final destination.</p> <p>Conditions beyond the control of Seller, including weather, available facilities and traffic conditions, may affect exact time of delivery. Seller shall not be responsible for specific carrier delivery date or time unless it has made a specific delivery commitment, in writing.</p> <p>Nonstandard methods of shipment and/or additional services are available upon request. Purchaser will be billed for the differential cost of any special services in excess of standard surface carrier freight costs. Premium charges, at Purchaser's request, will be added for airfreight, exclusive use of vehicle and extra, export or special packaging. Accessorial charges will be added for inside delivery, extra labor, reconsignment and redelivery.</p> <p>Partial shipments may be made and invoiced by Seller.</p>
Claims	<p>All shipments for Knoll Products within the contiguous United States and Canada are F.O.B. Origin. All risk of loss passes to Purchaser at time of delivery to carrier. Purchaser shall inspect all Products upon receipt and notify Seller within ten (10) working days after receipt of any damage or defects which are, or should be, apparent from an inspection of the Product and its packaging. Failure of Purchaser to notify Seller during the ten (10) working day period shall constitute acceptance of the Products and waiver of any apparent defects, errors or shortages. For all claims relating to Product damaged in transit or for any other claims relating to or arising out of the transportation of the Product, Purchaser must seek recovery from the carrier and Seller has no liability to Purchaser for such claims. Seller may, upon request, assist Purchaser with filing of such claims with the carrier, but Seller will not be liable for any of these transportation related claims.</p>
Seller's Security Interest	<p>Until Seller receives the full payment for the Product, Seller shall have a security interest in the Product. Purchaser agrees to perform all acts, including but not limited to the execution and filing of documentation, which may be necessary to perfect and assure the security interest of Seller.</p>
Returns	<p>The return of Products without a written authorization by Seller shall not be accepted. To receive authorization for Product return, please call Customer Service. All Products that are returned pursuant to a valid authorization shall be subject to a twenty-five percent (25%) of list restocking charge. Products not currently offered for sale by Seller (including COM) shall not be authorized for return. All returned Products must be unused, in original condition and in the original Seller packing cartons. No refund or credit shall be given for damaged Products.</p>
Held Orders/Storage	<p>If Purchaser requests that an order be held or delayed, prices and terms and conditions in effect at the time of shipment shall apply. If Purchaser requests a delay after the time when Seller can defer production, Purchaser will be invoiced for the Product, payable in accordance with standard terms, when the order is ready for shipment. Seller may transfer the Product to storage, in which case all expenses incurred in connection with storage, including demurrage, preparation for storage, storage charges and handling shall be payable by Purchaser upon submission of invoices by Seller. Risk of loss to the Product shall pass to the Purchaser upon delivery of the Product into storage.</p>

Selling Policy

Customer's Own Material	A Purchaser who requests a fabric or other surface material not standard to Seller's line of Products ("COM") must submit samples of the requested material to Seller prior to entry of a purchaser order. Seller shall determine if the material is suitable to its manufacturing processes and meets any requirements of Underwriters Laboratories. If the COM is acceptable, Seller will then establish a price for using the COM or the Product in question. For a description of the procedures for submitting samples and testing, contact customer resources or your sales representative. Seller shall have no responsibility for the appearance, condition, performance, durability, colorfastness or any other physical attribute of the COM. Purchaser shall indemnify and hold Seller harmless for any damages, injuries or losses arising out of or related to use of the COM on the Product.
Warranty	<p>Seller warrants to the original Purchaser only that the Products Seller manufactures and sells to Purchaser are free of defects in workmanship and materials, during the applicable warranty period set forth below.</p> <p>Warranty period set forth below is for 24-hour, 7 days a week, multi shift use (includes parts and labor to repair).</p> <p>Should any failure to conform with this limited warranty appear to a Product listed below during the applicable warranty period from the date of shipment, Seller shall, upon prompt written notice, repair or replace, at its option and costs, the affected part or parts.</p> <p><i>Product and Period of Warranty</i></p> <p><i>Lifetime: Antenna Workspaces, AutoStrada, Calibre, Crinion Open Table, Currents, Dividends Horizon, Morrison, Reff Profiles laminate, Rockwell Unscripted, Series 2 Storage, Template and other non-wood components (except cascade edge worksurfaces, operational parts, controls, electrical, Lighting, Series 2 Veneer Front Storage, upholstery, textiles and leathers, special or custom products, see below)</i></p> <p><i>12 Years: Chadwick, Essentials Work Chairs, Generation by Knoll, k. task, Life, Moment, MultiGeneration by Knoll, ReGeneration by Knoll, Remix, and Toboggan seating (except seating upholstery, textiles, leathers and finishes, see below).</i></p> <p><i>10 Year: Anchor Storage except digital keypad lock, Antenna Workspaces, AutoStrada, Crinion Open Table, Dividends Horizon, Dividends Horizon Satellite Surfaces, Reff Profiles, Rockwell Unscripted, Template wood components, Series 2 Veneer Front Storage, cascade edge worksurfaces, Wood Casegoods (The Graham Collection) (except wood casegoods upholstered surfaces, see below), Reuter overheads, Reuter vertical storage, KnollExtra Sapper Monitor Arm Collection, Sapper XYZ Monitor Arm Series, Adjustable keyboard mechanisms and platforms, Communication Boards (except fabric board textiles, cork and FilzFelt, see below), Smokador collection (except leathers, see below), Orchestra Universal Systems Accessories, k. lounge structural components, KnollStudio Pixel and Propeller, Tone bases.</i></p> <p><i>5 Years: Operational parts, controls, electrical, Lighting (except light ballasts, bulbs and power supply, see below), special or custom product, wood veneer products and plywood, Currents handcrank, KnollStudio, Rockwell Unscripted wire bases, Spark Series seating structural elements, structural elements of all KnollStudio outdoor products including all Richard Schultz designed products, KnollExtra CPU holders and all universal storage drawers and Power Collection, k. stand bases and HiLo.</i></p> <p><i>3 Years: Rockwell Unscripted upholstery (except textiles and leather), Office Seating upholstery, textiles, leathers and finishes. Fabric boards textiles and Smokador Collection leathers, KnollExtra Pop Up Screens.</i></p> <p><i>2 Years: Anchor Storage digital keypad lock, all other KnollExtra product</i></p> <p><i>1 Year: Light ballasts, bulbs and power supply, seating upholstered armpads and soft armpads, wood casegoods upholstered surfaces. KnollStudio, outdoor product finishes, k. lounge upholstery and k. lounge fabric. Rockwell Unscripted fabric and accessories.</i></p> <p>This warranty does not apply to:</p> <ul style="list-style-type: none">• Damage caused by a carrier other than the Seller.• Normal wear and tear or acts or omissions of parties other than Seller (including user modification, improper use or installation of Products).• COM or other third party materials applied to Products.• Products not installed by or under the auspices of a Knoll Dealer.• Dramatic temperature variations or exposure to unusual conditions.• Changes in surface finishes, including colorfastness due to aging or exposure to light.• Except as specifically noted above, textiles and upholstery supplied by KnollTextiles and Spinneybeck FilzFelt (consult current price lists for applicable warranties). <p>Natural variations occurring in wood, marble, and leather shall not be considered defects, and the Seller does not guarantee the colorfastness or matching of the colors, grains or textures, or surface hardness of such materials. The Seller also does not guarantee the colorfastness of fiberglass panel surfaces.</p> <p>THE EXPRESS WARRANTIES CONTAINED HEREIN ARE IN LIEU OF ALL OTHER WARRANTIES, EXPRESS OR IMPLIED, INCLUDING ANY WARRANTIES OF MERCHANTABILITY AND FITNESS FOR PARTICULAR PURPOSE AND ALL OTHER WARRANTIES ARISING FROM COURSE OF DEALING OR USAGE OF TRADE.</p> <p>The remedies provided above are the Purchaser's sole remedies for any failure of Seller to comply with its obligations regarding the workmanship of its Products. Correction of any nonconformity in the manner and for the period of time provided shall constitute complete fulfillment of all liabilities of Seller, with respect to or arising out of the Product furnished hereunder.</p>
Delay/Force Majeure	Seller shall not be liable for failure to perform or for delay in performance due to fire, flood, strike or other labor difficulty, act of God, act of war or terrorism, act of any governmental authority or of the Purchaser, riot, embargo, fuel or energy shortage, wrecks or delay in transportation, inability to obtain necessary labor, materials or manufacturing facilities from usual sources or failure of suppliers to meet their contractual obligations, or due to any cause beyond its reasonable control. If any such event occurs, Seller may extend delivery dates by a period of time necessary to overcome the effect of such delay, allocate available Product or cancel any purchase order.
Compliance with Law	PURCHASER IS SOLELY RESPONSIBLE FOR COMPLIANCE WITH ALL APPLICABLE FEDERAL, STATE AND LOCAL LAWS, ORDINANCES, REGULATIONS, RULES AND STANDARDS RELATING TO THE INSTALLATION, MAINTENANCE, USE AND OPERATION OF THE PRODUCTS.
Patents	<p>Subject to the following provisions, Seller shall, at its own expense, defend or, at its option, settle any claim, suit or proceeding brought against the Purchaser, and/or its vendees, mediate and immediate, so far as based on an allegation that any Product or any part thereof furnished hereunder constitutes a direct or a contributory infringement of any claim of any patent of the United States or Canada. This obligation shall be effective only if Purchaser shall have made all payments then due hereunder and if Seller is notified promptly in writing and given authority, information and assistance for the defense of said claim, suit or proceeding. Seller shall pay all damages and costs awarded in such suit or proceedings so defended.</p> <p>The foregoing indemnity does not apply to the following:</p> <ul style="list-style-type: none">• Products supplied according to a design other than that of Seller, and which is required by the Purchaser.• Combination of the Product with another product not furnished hereunder unless Seller is a contributory infringer.• Any settlements of a suit or proceeding made without Seller's written consent.
Limitations of Liability	<p>SELLER, ITS CONTRACTORS, AUTHORIZED DEALERS AND SUBCONTRACTORS OR SUPPLIERS OF ANY TIER SHALL NOT BE LIABLE TO PURCHASER FOR ANY SPECIAL, INDIRECT, INCIDENTAL OR CONSEQUENTIAL DAMAGES ARISING FROM A BREACH OF THIS AGREEMENT.</p> <p>Purchaser's remedies set forth herein are exclusive and the liability of Seller with respect to the breach of this agreement or any contract entered into between the parties pursuant hereto shall not exceed the price of the Product or part on which such liability is based.</p>

General Ordering Information

The Products

This guide encompasses all standard products for this product group.

Sizes

Dimensions listed in this guide are indicated as:

H = height

W = width

D = depth

Dia. = diameter

Rad. = radius

Pricing

All prices shown are list.

How to Order

Select pattern numbers and quantities required for your complete installation. Product questions can be addressed in the specific sections of this guide or by contacting your sales representative or customer resource representative at 1-800-343-5665.

Next, select options (if required), along with colors and finishes appropriate to each product. Reference the Finishes and Fabrics pages for color designations.

On large installations, an item's "designated area" can be specified to assist in product organization and handling.

To expedite complete / correct entry of your order, be certain all pattern numbers, quantities, colors and area identifications are completely specified. Also, include complete purchase order numbers, bill-to and ship-to addresses, a contact name and specific factory shipping dates required.

Mail all orders to:

Knoll, Inc.

1235 Water Street

P.O. Box 157

East Greenville, PA 18041

Attention: Order Entry

Once your order is entered at Knoll, an acknowledgment will be mailed to you. You will be advised of your scheduled shipping date within five days of the original acknowledgment. If it is necessary to revise your order, please contact your customer resource representative.

Sustainability Statement

Sustainable design is a key component of Knoll's environmental focus. Our commitment to social responsibility and a healthy environment has prompted us to further articulate our longstanding environmental programs and, with encouragement and support from our colleagues in the industry, we have re-energized our focus on such "green" initiatives as life cycle analysis and LEED™ certification. Knoll is proud to have contributed to projects that have received LEED certification from the U.S. Green Building Council.

For the latest information on Knoll products that help our customers achieve LEED certification, log on to knoll.com, click on "About Knoll" and then "Environmental Focus."