

DUAL BRAKE SYSTEM CASTER (PLATE TYPE)

LOAD CAPACITY
100 kg
220 lbs

TEST 13
P.698



EX-100PS, P



EX-100P
(w/o Brake)

EX-100PS
(w/Brake)



Lock Indicator

- Locks both wheel and swivel.
- Ball bearing equipped in both swivel and wheel to provide maximum smooth movement.
- Front rubber bumper protects from impact.
- Large brake lever and indicator for easy operation.

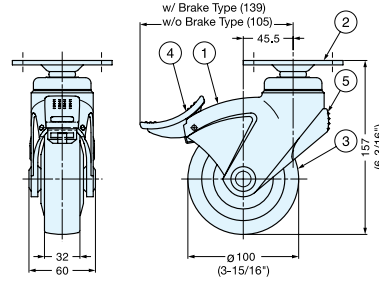
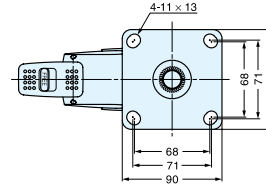

Item No.	Load Capacity (kg)	Weight (g)	Box (pcs)	Carton (pcs)
EX-100PS w/Brake	100 (220 lbs)	919	20	200
EX-100P w/o Brake		877		

No.	Part Name	Material	Finish
①	Body	Polyamide	Light Grey
②	Mounting Plate	Steel	Yellow Zinc Chromate
③	Wheel	Polyamide Polyurethane	Grey
④	Brake	Polyamide	
⑤	Rear Bumper	Elastomer	

DUAL BRAKE SYSTEM CASTER (THREADED BOLT TYPE)

LOAD CAPACITY
100 kg
220 lbs

TEST 13
P.698

EX-100N



(w/o Brake)

(w/Brake)

- Locks both wheel and swivel.
- Ball bearing equipped in both swivel and wheel to provide maximum smooth movement.
- Front rubber bumper protects from impact.
- Large brake lever and indicator for easy operation.

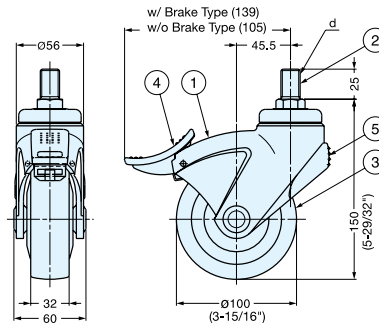
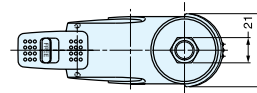

Item No.	d	Load Capacity (kg)	Weight (g)	Box (pcs)	Carton (pcs)
EX-100N12S w/Brake	M12×1.75	100 (220 lbs)	703	20	200
EX-100N12 w/o Brake	M12×1.75		658		
EX-100N16S w/Brake	M16×2.0		703		
EX-100N16 w/o Brake	M16×2.0		658		

No.	Part Name	Material	Finish
①	Body	Polyamide	Light Grey
②	Threaded Bolt	Steel	Yellow Zinc Chromate
③	Wheel	Polyamide Polyurethane	Grey
④	Brake(w/Brake type) Front Bumper(w/o Brake type)	Polyamide Elastomer	
⑤	Rear Bumper	Elastomer	