

If you have a problem, question, or request, call your local dealer, or Steelcase Line 1 at **888.STEELCASE** (888.783.3522) for immediate action by people who want to help you.

(Outside the U.S.A., Canada, Mexico, Puerto Rico, and the U.S. Virgin Islands, call: 1.616.247.2500)  
Or visit our website: [www.steelcase.com](http://www.steelcase.com)



© 2015 Steelcase Inc.  
Grand Rapids, MI 49501  
U.S.A.

Printed in U.S.A.

## FOOTREST DISASSEMBLY

1. Pry off base ring with flat bladed screwdriver and discard.
2. Remove (5) screws with T30 TORX drive.
3. Cut fabric away from polyurethane foam/shell assembly and discard all parts.
4. Pry off staples and fabric loop. Discard loop and polypropylene parts as shown.

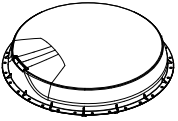
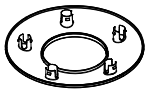
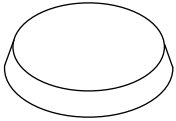
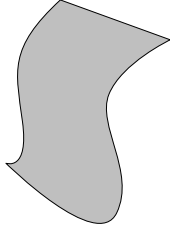
### Bins for components removed

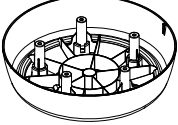

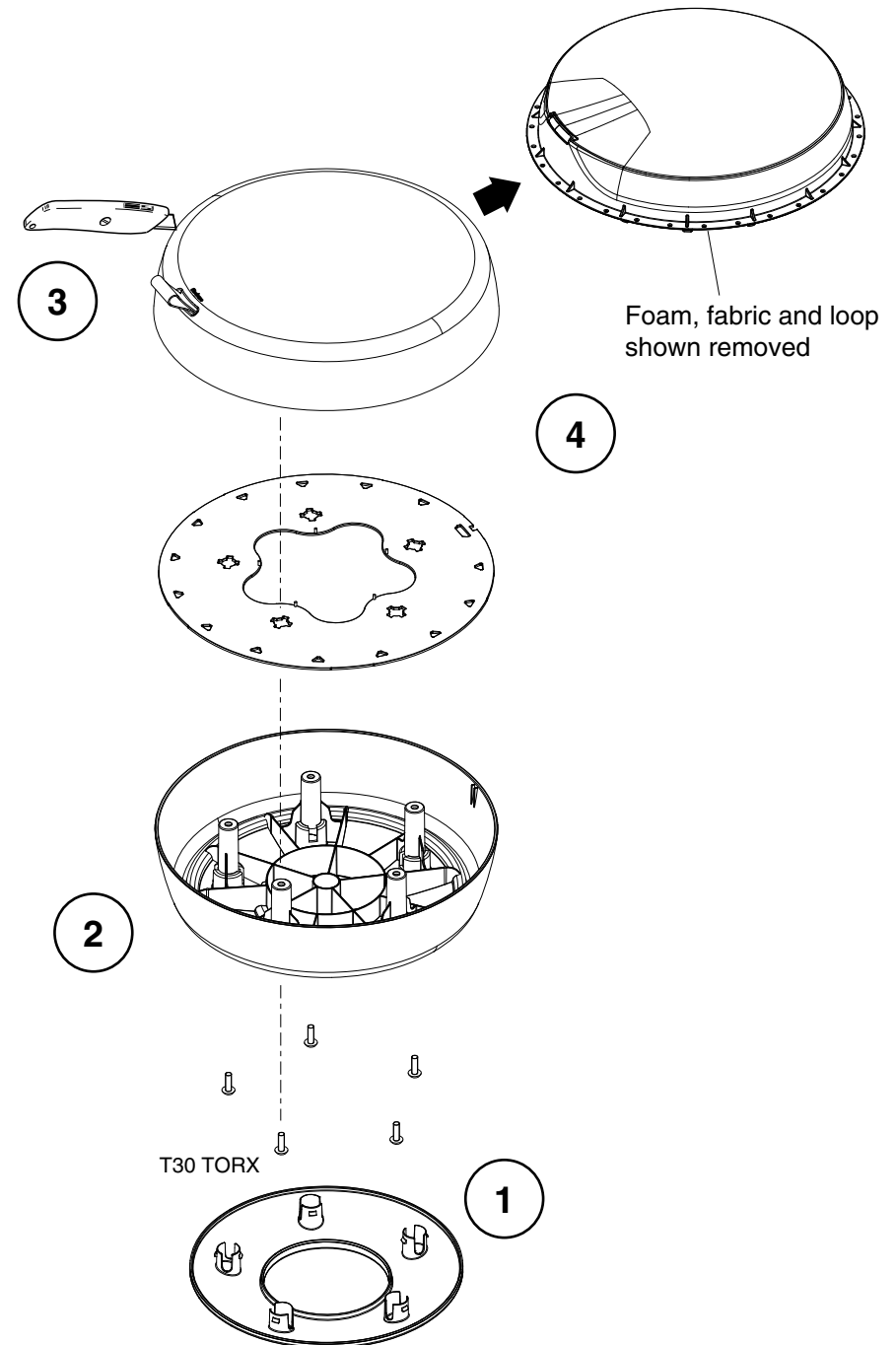
POLY-PROPYLENE	TPU	POLYURETHANE FOAM	FABRIC
			
			
			



## SCREEN DISASSEMBLY

1. Pry top caps off and discard.
2. Remove all screws from the screen bases (T30 TORX + 12" BIT HOLDER). Loosen middle brackets (3mm HEX) if needed.
3. Lift the screens from the base. Set aside.
4. Remove the (2) screws (T30 TORX) from the middle brackets and discard.

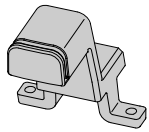
### Bins for components removed

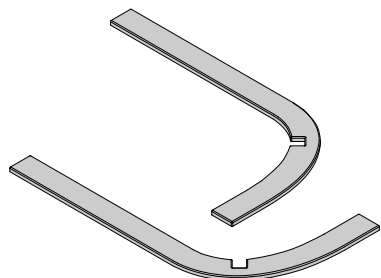
ALUMINUM	STEEL	SCRAP
	 (all)	

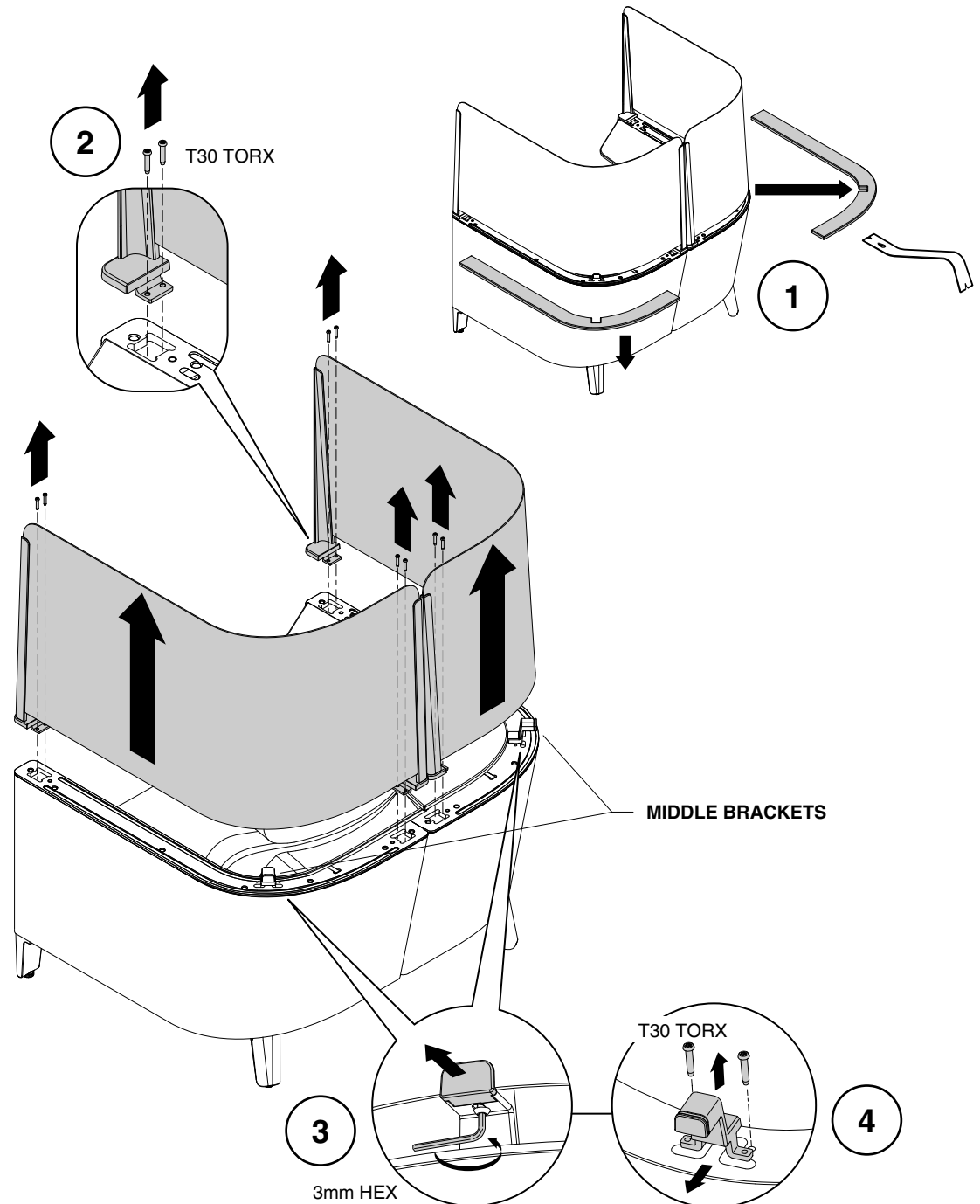

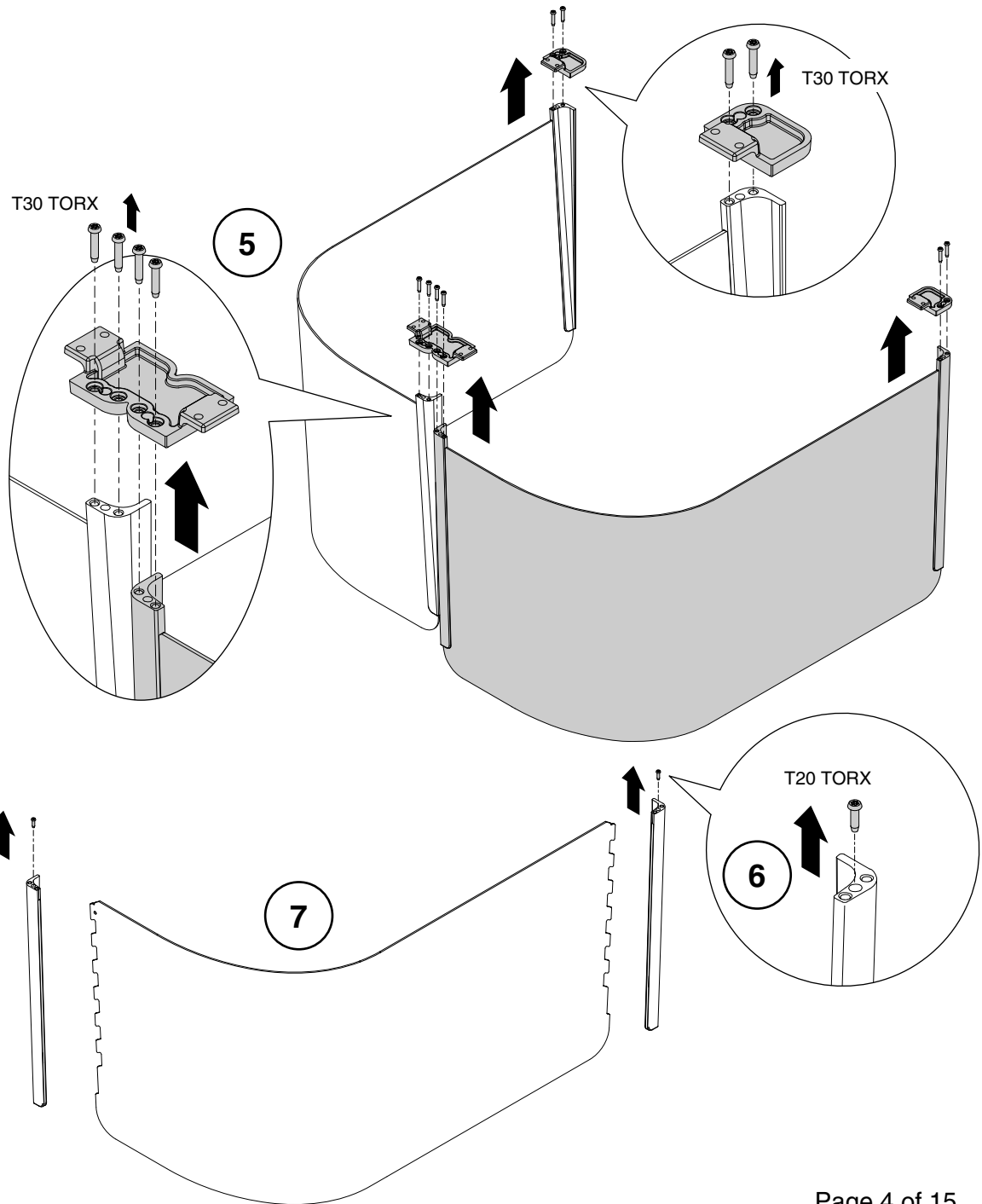

## SCREEN DISASSEMBLY (continued)

5. Remove all attaching screws (T30 TORX) from the mounting plates and discard.
6. If screen(s) are fabric-covered, refer to Page 5. Remove screws (T20 TORX) from the bottom of screen uprights. Disengage the uprights from the screen hooks and discard.
7. Discard screen(s).

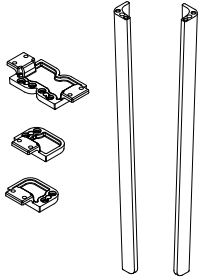
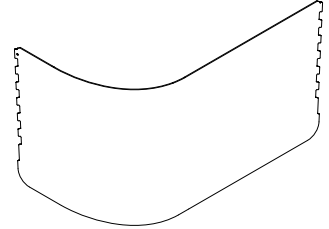

### Bins for components removed



ALUMINUM	ACRYLIC*	STEEL
	 *see page 5 if fabric-covered	 (all)

## FABRIC-COVERED SCREEN DISASSEMBLY

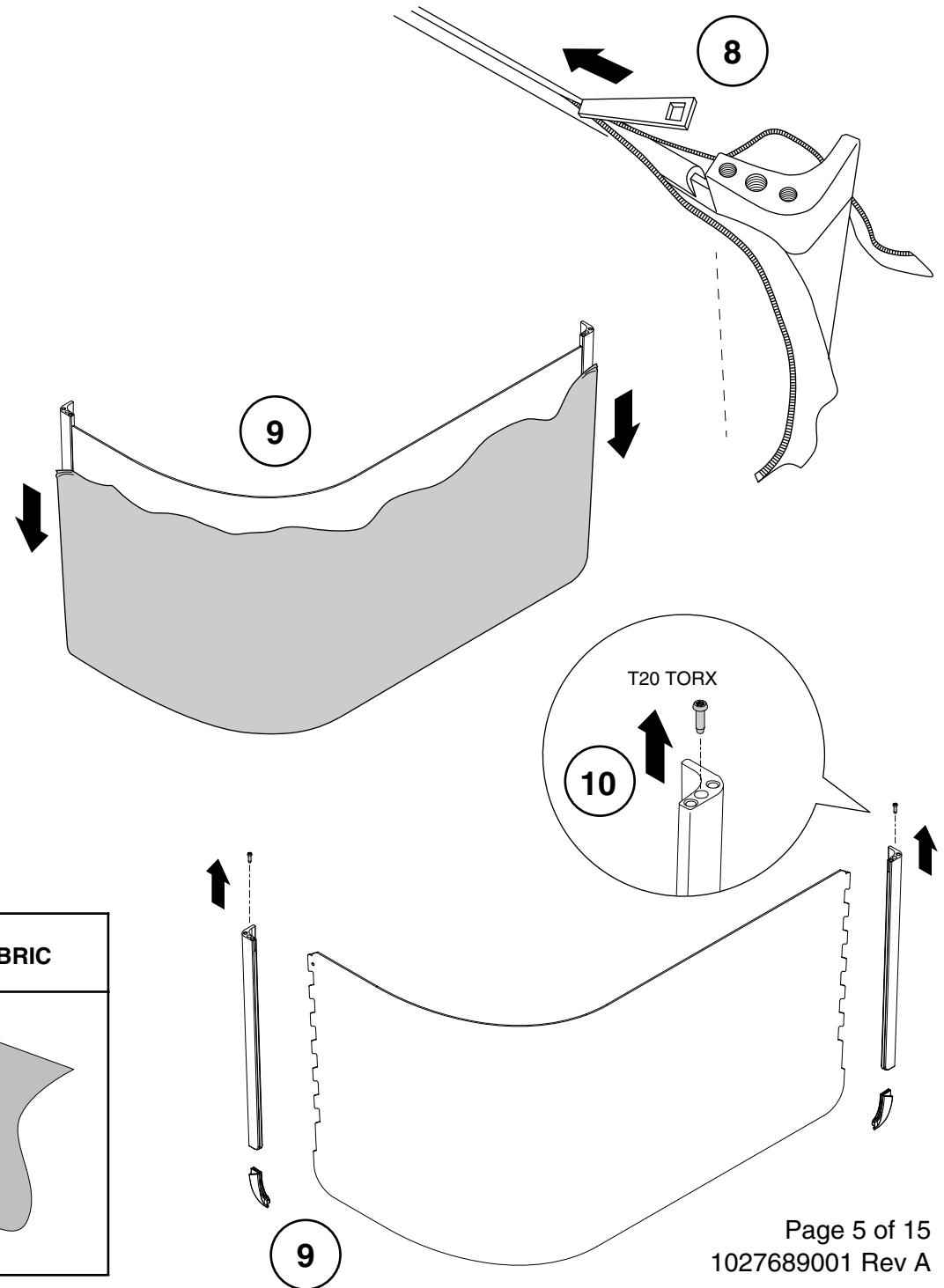
8. Locate zipper on the bottom of the fabric sock. Unzip the entire length.
9. Peel fabric sock off of steel screen substrate and remove both top corner pieces. Discard fabric and corner pieces.
10. Remove screws (T20 TORX) from the bottom of screen uprights. Disengage the uprights from the screen hooks and discard.
11. Discard screen(s).

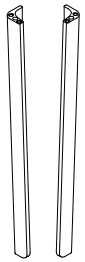

### Bins for components removed

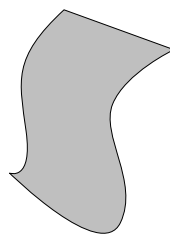
STEEL	ALUMINUM	ABS	FABRIC
 (all)			

## PERSONAL WORKSURFACE DISASSEMBLY

1. Remove screens (not shown), if applicable. Refer to Page 3.
2. Pry off top caps (unless already done in screen removal step). Discard.
3. a. Remove (2) screws (T30 TORX) underneath, b. (1) screw (T40 TORX) from the side c. (2) screws (T40 TORX) on top and to remove the personal worksurface. Set aside personal worksurface for further disassembly.

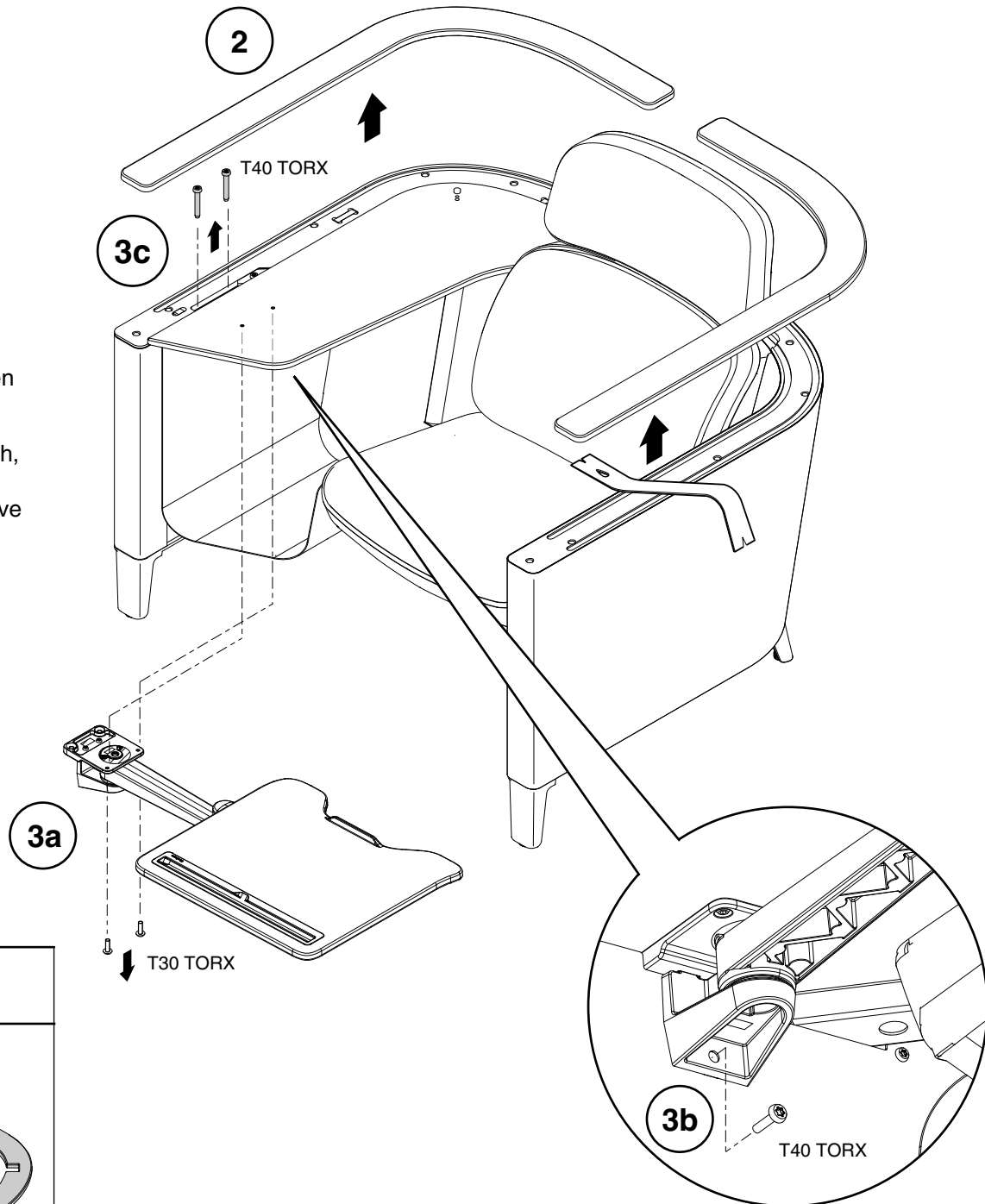

### Bins for components removed

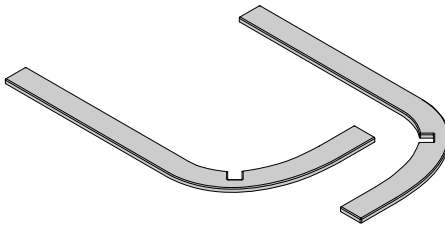
STEEL	SCRAP
 (all)	

## PERSONAL WORKSURFACE DISASSEMBLY (continued)

4. Pry bottom cover off and discard.
5. Remove (6) screws (T40 TORX) and separate worksurface from mechanism.
6. Turn worksurface over and pry out the insert.
7. Remove remaining screws and discard items into appropriate bins.

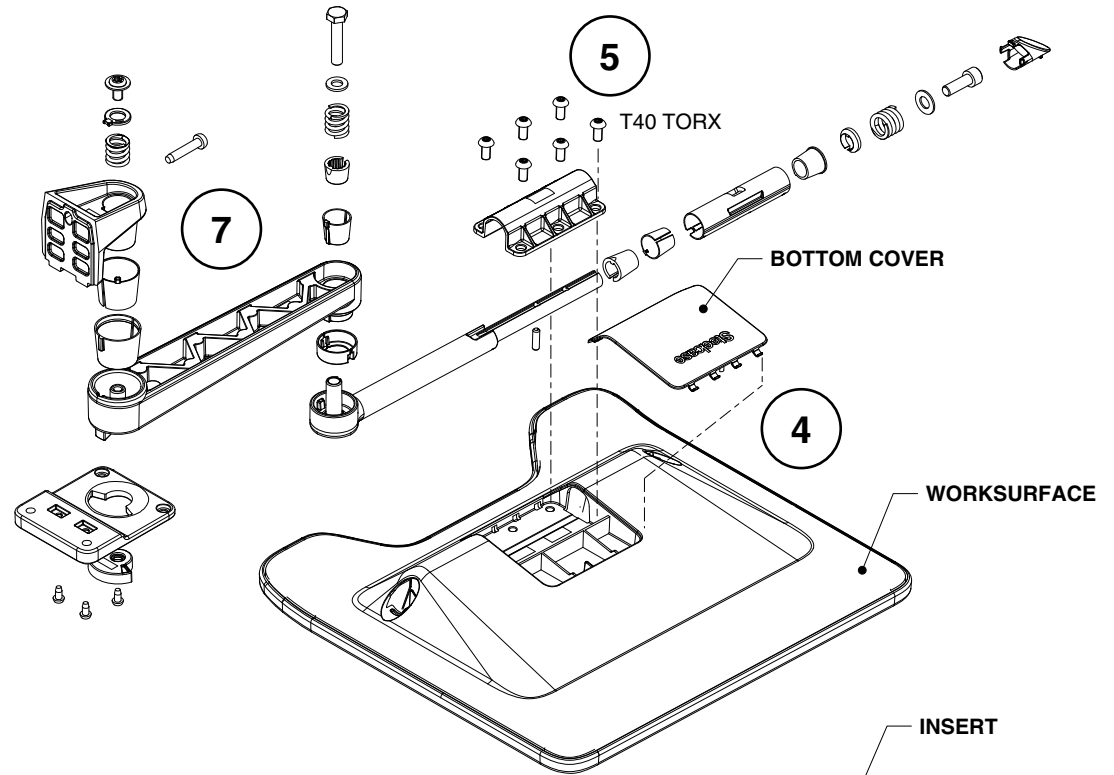

### Bins for components removed

STEEL	ALUMINUM	NYLON	ACETAL	ASA+PC BLEND	ABS WITH TPU OVERMOLD

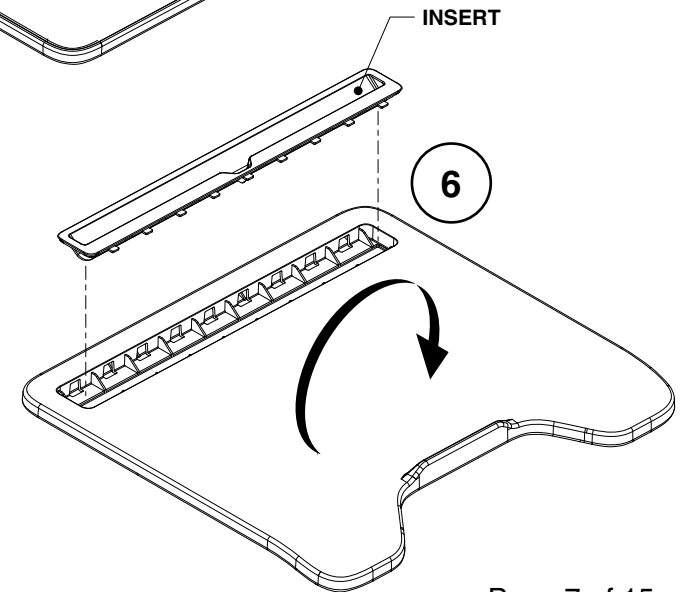

## LIGHTING DISASSEMBLY

1. Unplug light power cord.
2. Unplug power cord from light fixture.
3. Lift up to remove light fixture from base and discard.
4. Unscrew nut (8mm socket) from base and discard.
5. Remove base from worksurface and pull power cord through the hole. Remove foam washer and discard base and washer.

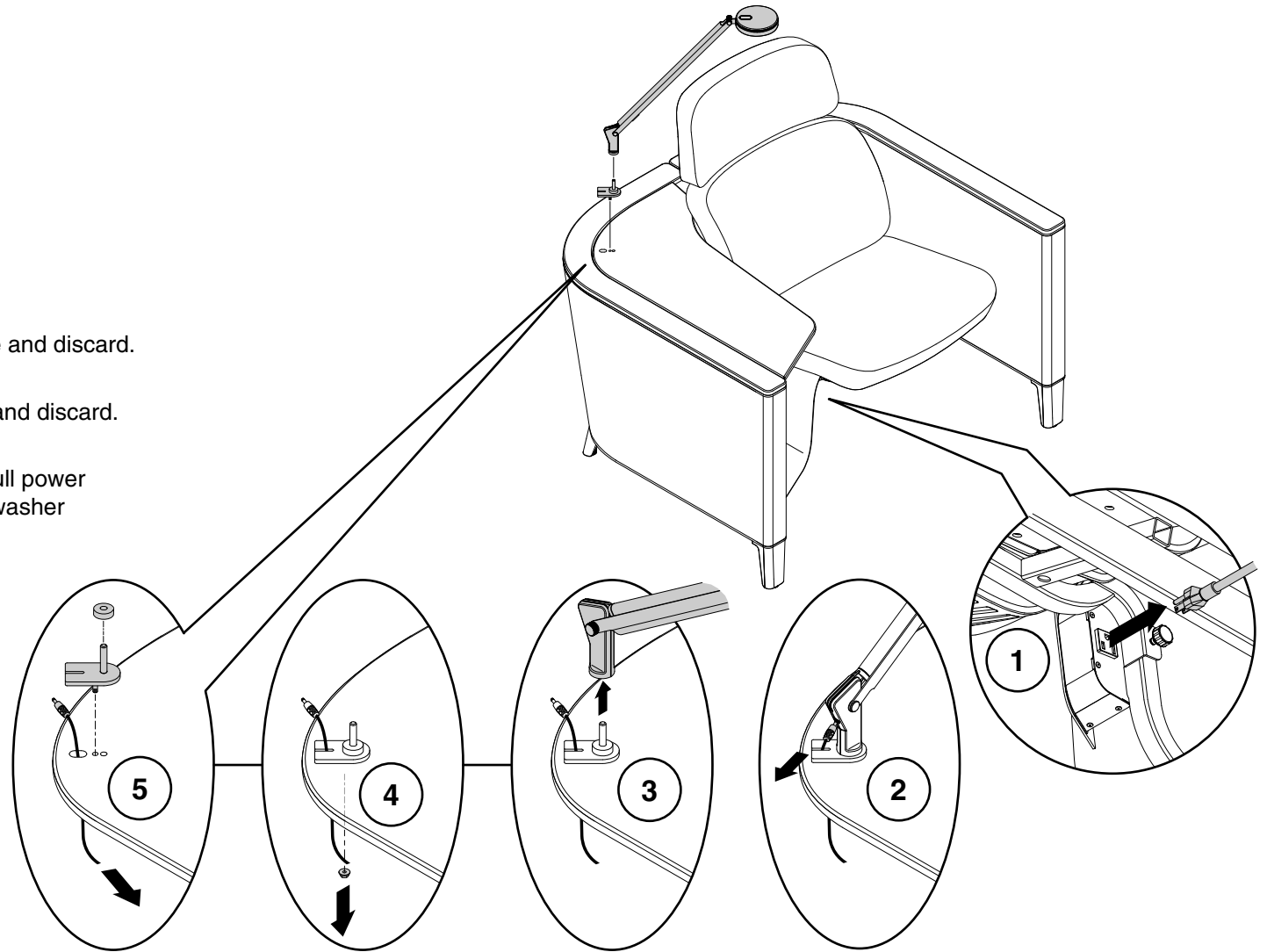

### Bins for components removed

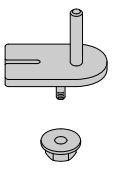
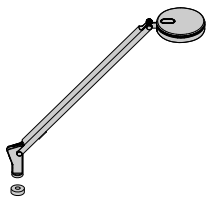
STEEL	SCRAP
	



## BASE AND EXTENSION DISASSEMBLY

1. Remove screws (T30 TORX) from legs.
2. Remove glides from legs. Discard glides. Remove threaded inserts from legs with flat bladed screwdriver and discard inserts and legs.
3. Remove screws (T30 TORX) from L-brackets and ganging bracket if an extension unit is involved. Discard.

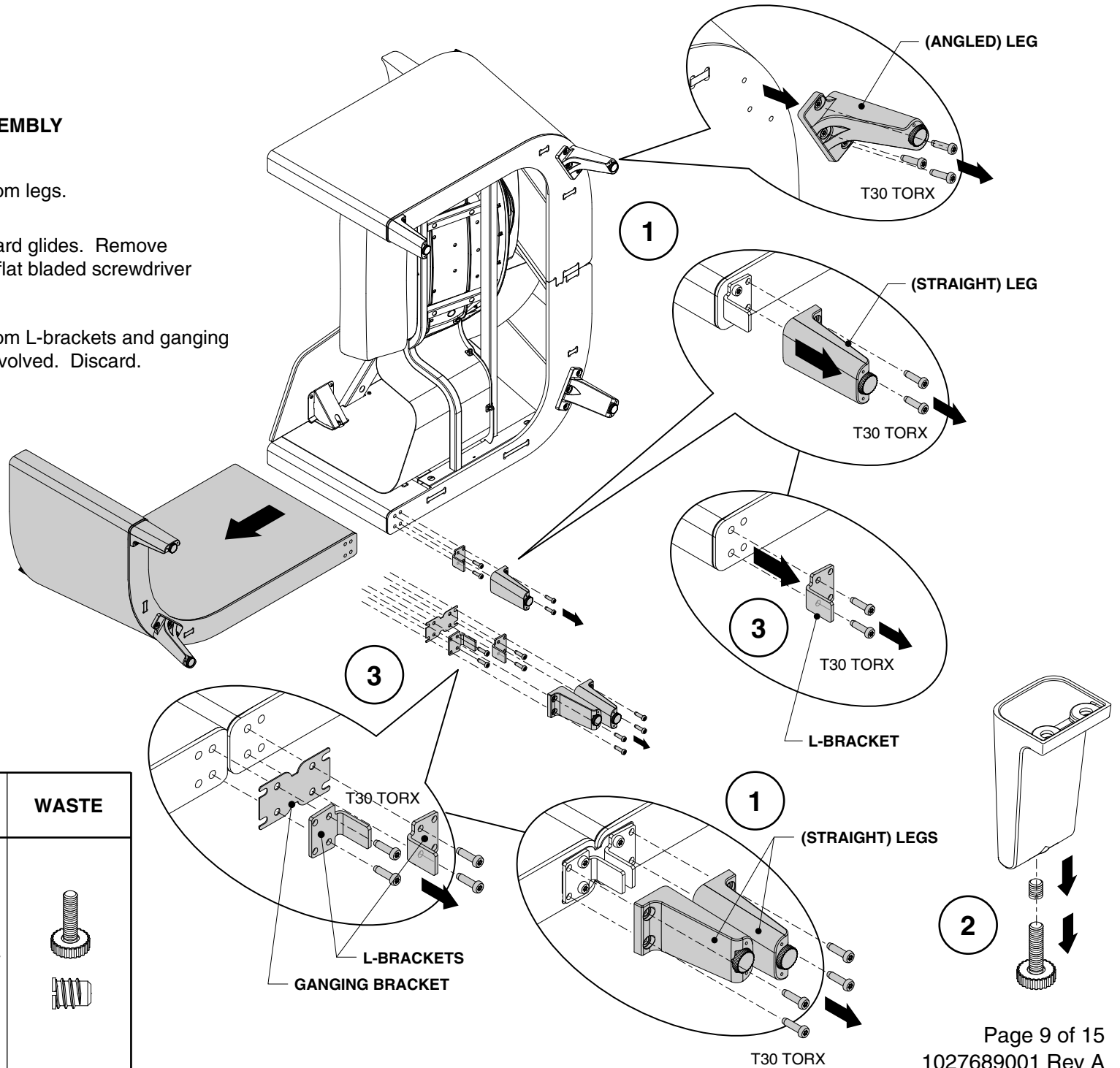

### Bins for components removed

STEEL	NYLON	WASTE

## POWER DISASSEMBLY

1. Unplug power cord from power source.
2. Turn thumbwheel counterclockwise until unit is loose.
3. Remove and discard unit.

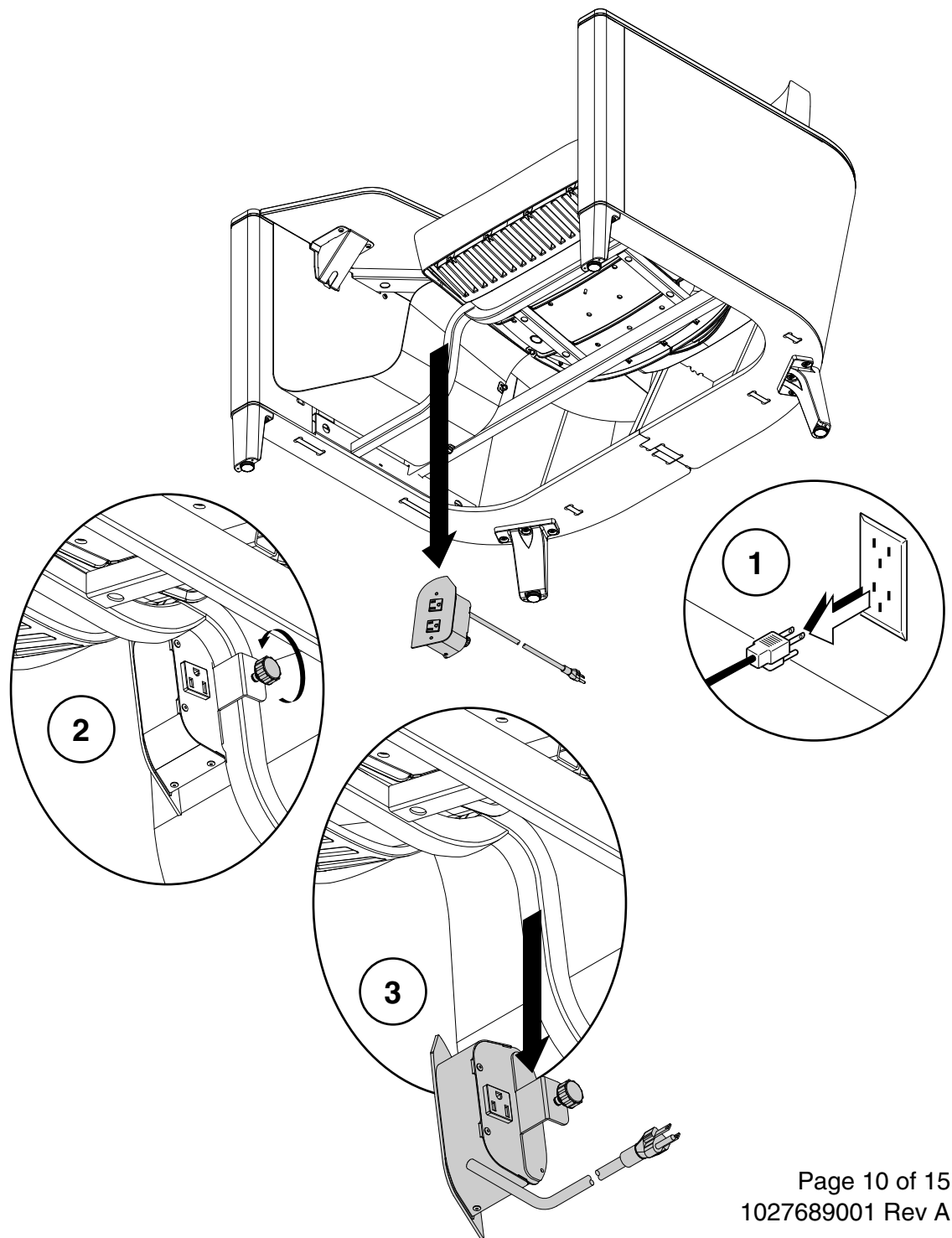

### Bins for components removed

SCRAP

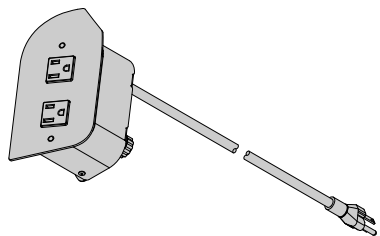

## BASE DISASSEMBLY

1. Disengage backrest from mounting panel by depressing the release trigger with a finger. Lift backrest up and put aside.
2. Disengage seat from base by removing (4) screws (6mm HEX). Lift seat up and put aside.

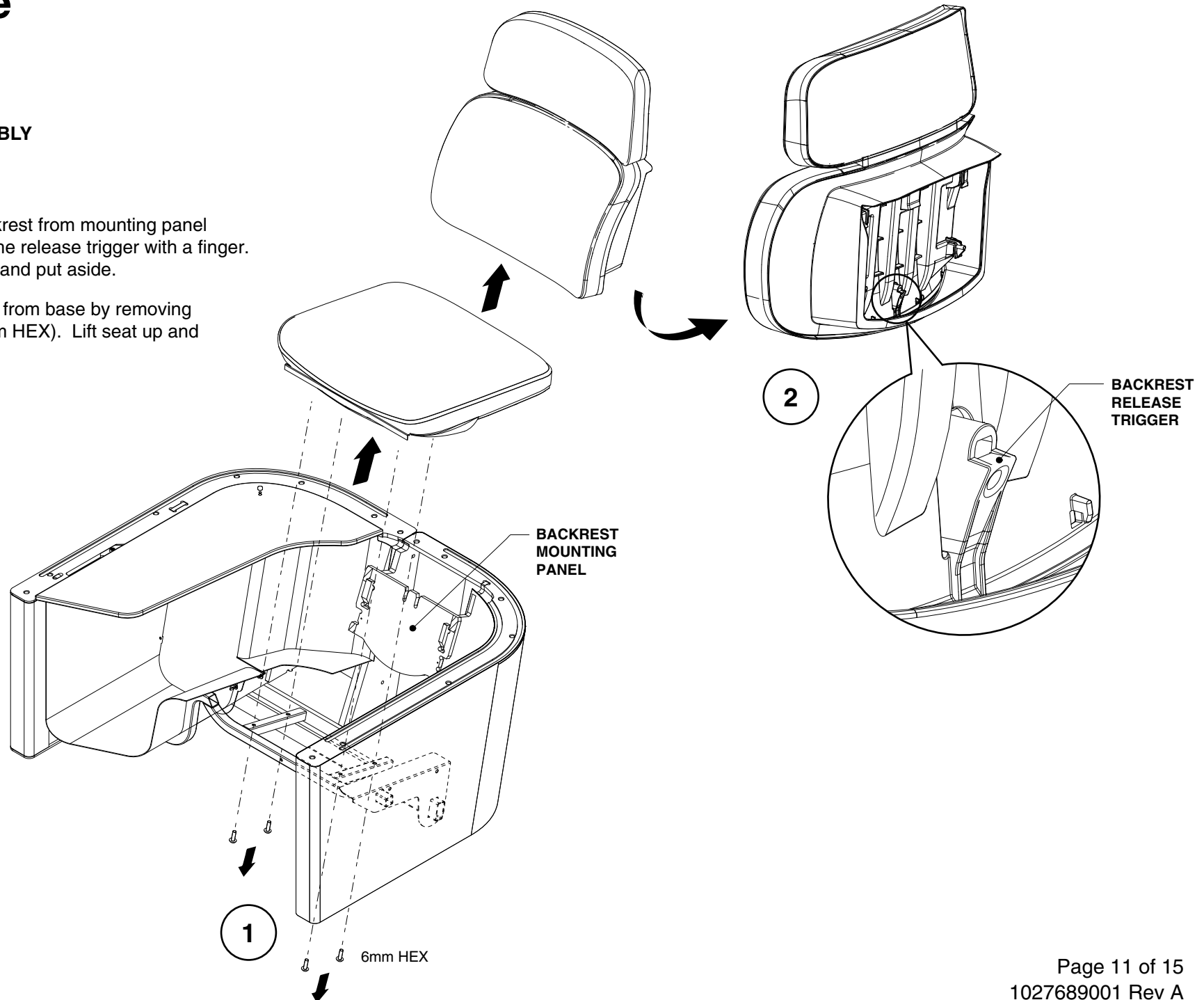

## BASE DISASSEMBLY (continued)

3. Remove (2) screws (4mm HEX) from the under the side surface and remove it.
4. If unit did not have a Personal Worksurface (shown on page 6), locate and remove (3) screws (T30 TORX) and (2) screws (T40 TORX) to remove the brace shown. Discard the side surface and brace.
5. Remove (2) screws (T40 TORX) and lift side support bracket off to discard.
6. Remove (2) screws (T30 TORX) and lift caddy out of the base to discard.
7. Turn side surface over and remove (2) screws (4mm HEX) to separate the mounting bracket, then discard. Remove (1) screw (5mm HEX) and washer and discard.

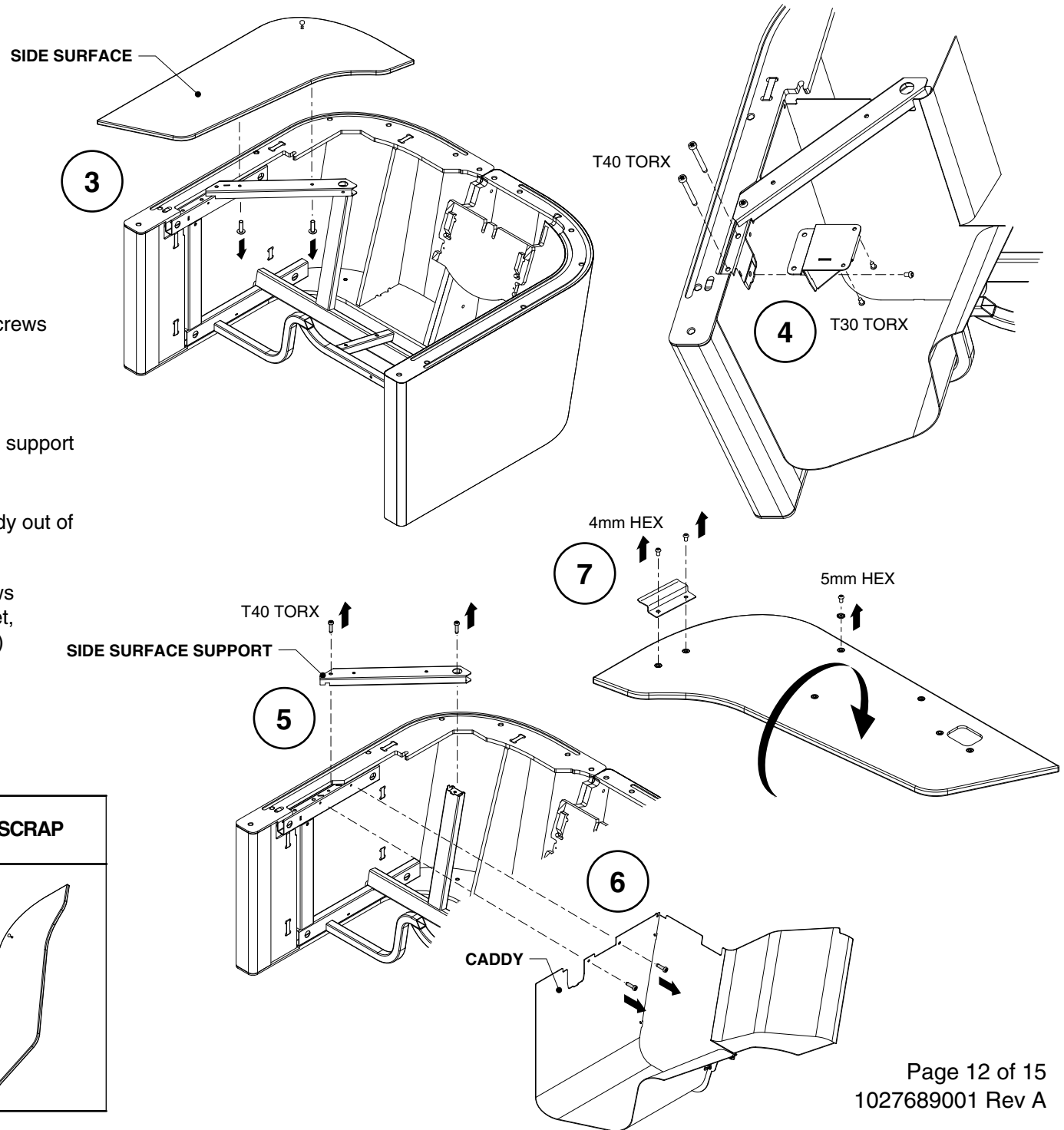

## Bins for components removed

STEEL	SCRAP

## BASE DISASSEMBLY (continued)

8. Remove (2) bolts (6mm HEX), washers and nuts.
9. Remove (7) screws (T40 TORX). Discard welded steel structure and base halves.

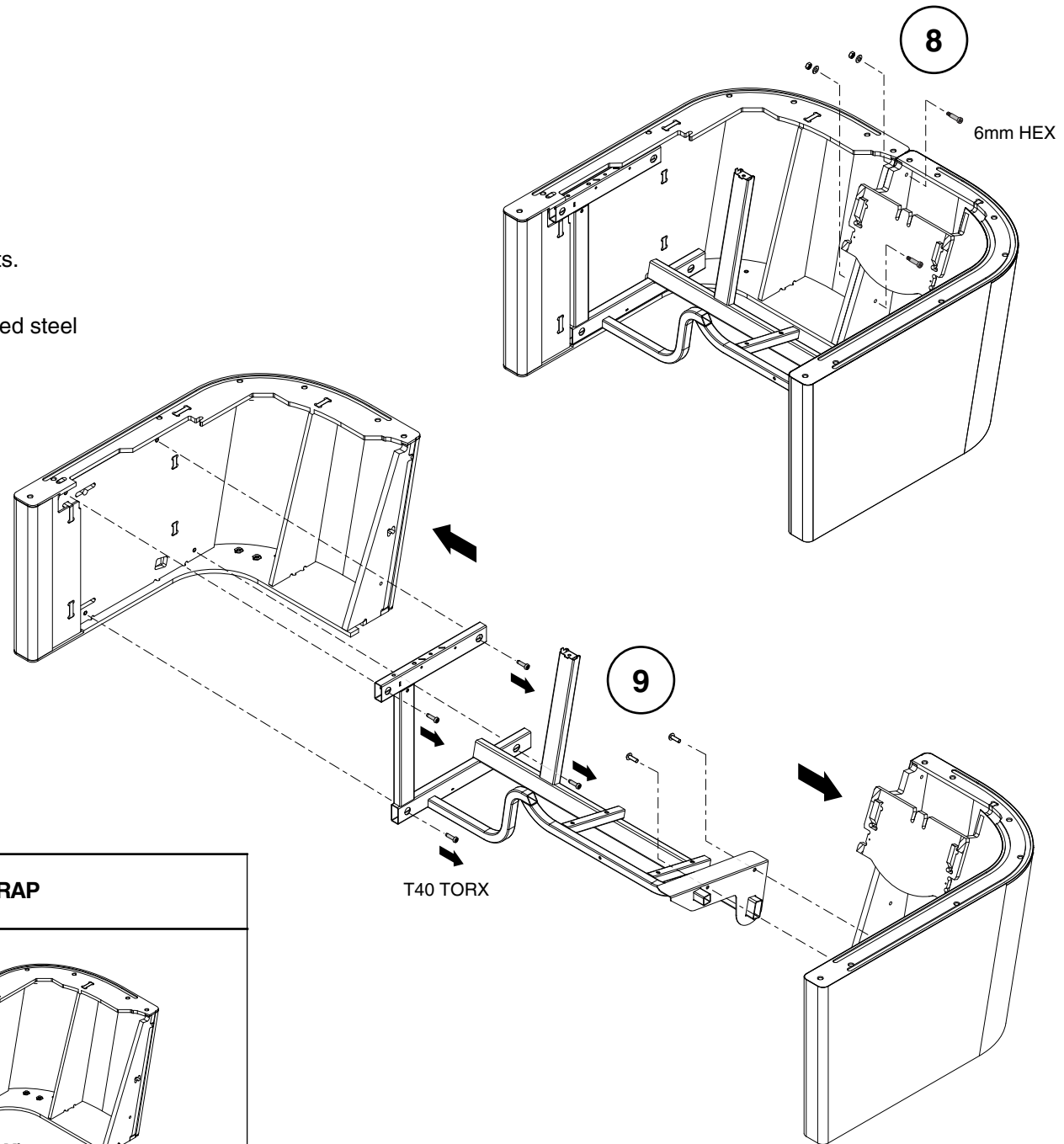

### Bins for components removed

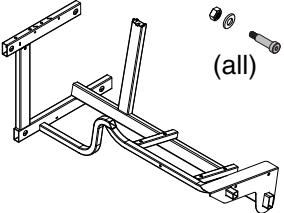
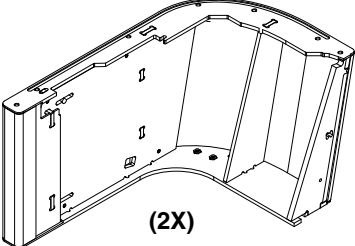
STEEL	SCRAP
 <p>(all)</p>	 <p>(2X)</p>

## BACKREST DISASSEMBLY

1. Cut fabric away from foam/shell assembly and discard.
2. Peel foam from shell and discard.
3. Disassemble outer backrest components. Remove all staples and discard.
4. Pry steel lumbar wires from the backrest inner shell and discard. Discard inner shell.

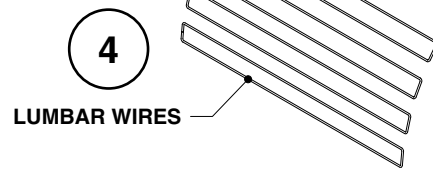
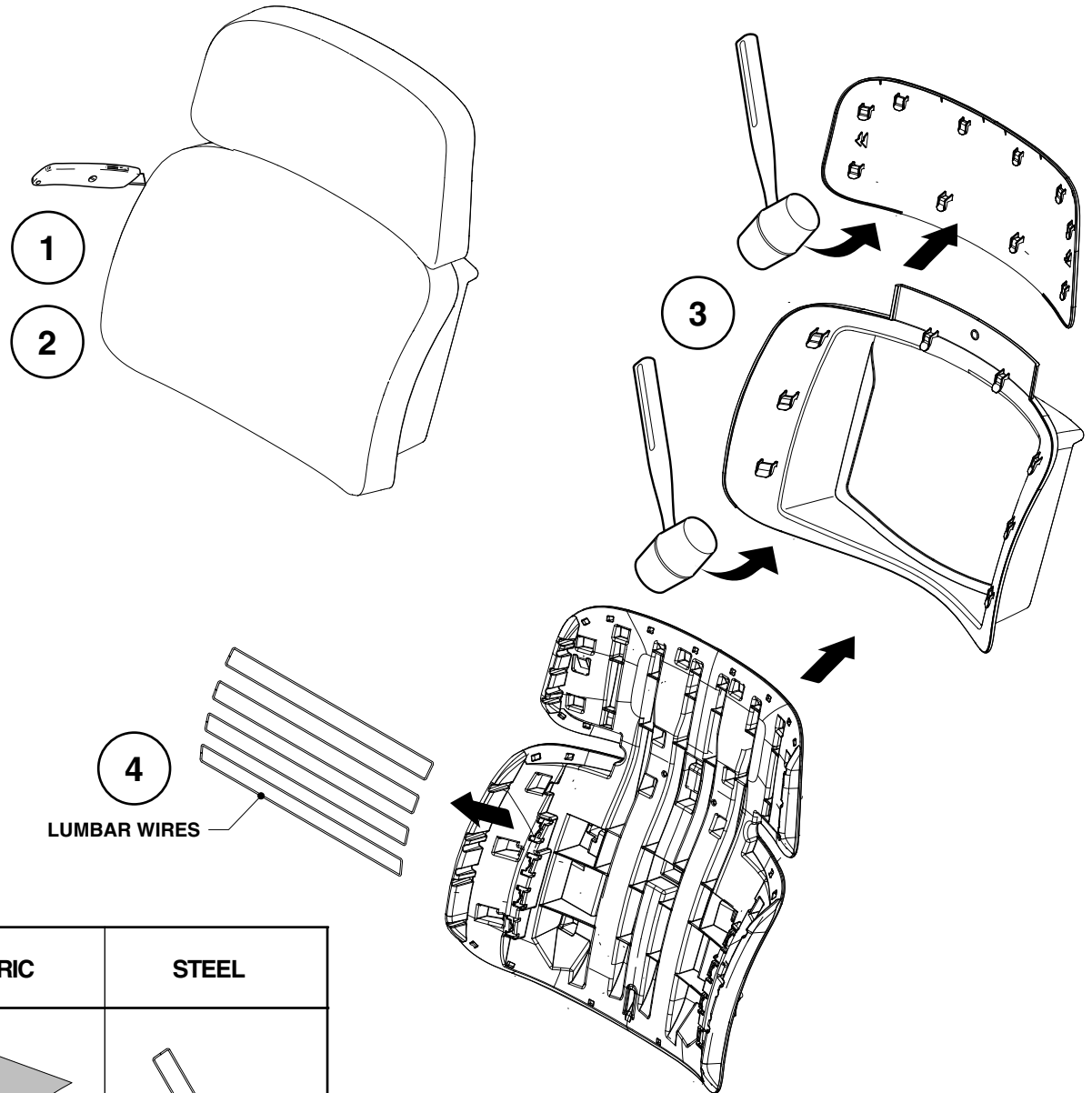

### Bins for components removed



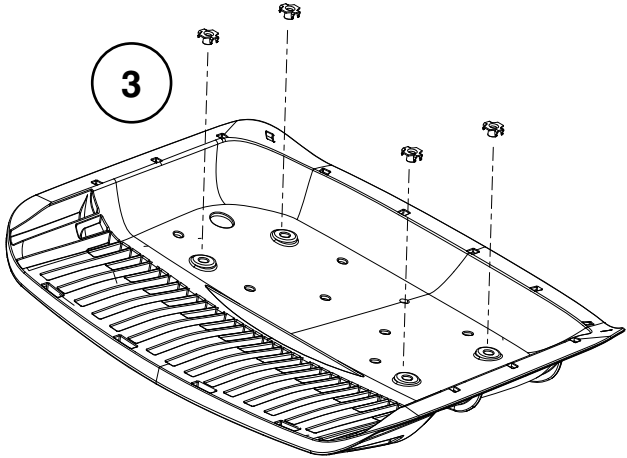
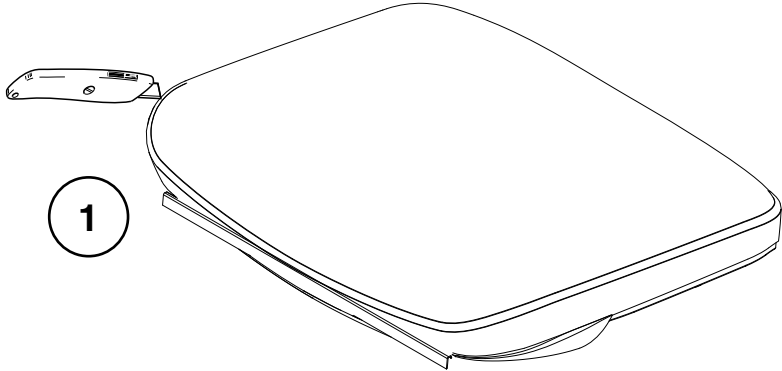

POLYPROPYLENE	FOAM	FABRIC	STEEL
			 (4X)

## SEAT DISASSEMBLY

1. Cut fabric away from foam/shell assembly and discard.
2. Peel foam from shell and discard.
3. Pry out (4) threaded inserts and staples before discarding shell.

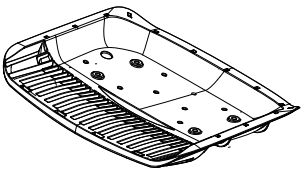

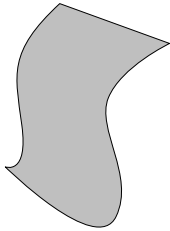
Bins for components removed

POLYPROPYLENE	FOAM	FABRIC	STEEL
			 (4X)