

# WOODWORKS® Grille System

## Assembly and Installation Instructions

### 1. GENERAL

#### 1.1 Product Description

The WoodWorks® Grille system is a solid wood ceiling system available in a variety of standard slat heights and depths and four warm wood finishes – Grille Maple, Grille Light Cherry, Grille Dark Cherry, and Grille Walnut – as well as White painted. Both the nominal 12" x 96" panels and installation system are provided by Armstrong. Panels can be installed with Heavy Duty Prelude® 15/16" suspension system with a dowel or backer, or backer and dowel combination. Custom finishes, and slat heights, as well as a flexible backer for curved applications, are offered through Armstrong. For applications where the WoodWorks Grille system is to be installed on a slope, contact TechLine<sup>SM</sup> for further instructions and drawing details.

#### 1.2 Material and Surface Finish

Slats, backers, and dowels are constructed from solid poplar. Slats have a semi-gloss coating, or painted finish. Backers and dowels have a black factory finish.

#### 1.3 Storage and Handling

All ceiling components should be stored in a dry interior location and shall remain in the original packaging prior to installation to avoid damage. The materials shall be stored off the floor in a flat, level condition. Do not store in unconditioned spaces with humidity greater than 55% or lower than 25%, or with temperatures above 86°F or lower than 50°F. Use proper care when handling to avoid damage or soiling. WoodWorks Grille panels can be cleaned with a soft dry cloth.

**CAUTION:** Use proper care and caution when handling suspension systems due to the sharp edges on all exposed clips.

#### 1.4 Site Conditions

Building areas that will receive a ceiling shall be free of construction dust and debris. Installation of the products shall be carried out where the temperature is between 50°F and 86°F and relative humidity levels maintained between 25% RH and 55% RH. These temperature and humidity conditions must be met throughout the lifetime of the ceiling.

Real wood and wood composite products are natural building materials and they will react to changes in humidity. (Wood tends to contract with lower humidity and expand with higher humidity.)

Wood may also have a tendency to warp, twist, or bow, due to the natural stresses in the components and these humidity changes. Be aware of these natural tendencies when evaluating the products.

It is also necessary for the area to be enclosed and for the HVAC systems to be functioning and in continuous operation. All wet work (plastering, concrete, etc.) must be complete and dry. These products cannot be used in exterior applications.

To ensure that the ceiling panels have stabilized to the current building conditions, prior to their installation, the planks must be placed in an environmentally stable building location for a minimum of 72 hours.

#### 1.5 Color

WoodWorks Grille panels are made of solid wood and are available in a variety of standard finishes. Custom options are available. Natural variations in color and grain are characteristic of wood products. To maximize visual consistency, panels should be unpacked and examined collectively to determine the most desirable arrangement for installation.

#### 1.6 Ordering Considerations

Be sure to account for extra material that is normally needed for wood installations. When installing WoodWorks Grille panels, you should consider ordering at least 5% extra material.

Up to 10% more may be needed for odd size or diagonal installations. It is the customer's responsibility to plan each layout and order the correct amount of installation material needed, taking into account their design.

#### 1.7 Fire Performance

As with other architectural features located at the ceiling, WoodWorks Grille panels may obstruct or skew the planned fire sprinkler water distribution pattern, or possibly delay or accelerate the activation of the sprinkler or fire detection systems by channeling heat from a fire either toward or away from the device. Designers and installers are advised to consult a fire protection engineer, NFPA 13, and their local codes for guidance where automatic fire detection and suppression systems are present.

## 2. WOODWORKS® GRILLE PANELS AND ACCESSORIES

### 2.1 Wood Slats

WoodWorks Grille panels are available in a variety of standard slat heights and widths as well as custom options.

### 2.2 Backer Clips and Dowel Clips

Metal spring clips are used to attach panels to 15/16" Black Prelude® T-Bar suspension system.

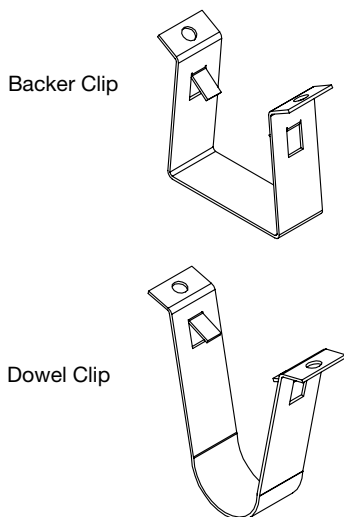

**NOTE:** Backer clips are to be used with grille panels that have a backer and dowel combination.

### 2.3 Trim Accessories

Wood trim options are available in coordinating slat finishes:

- Ledgers for wall molding trim



- Junctions for panel joints (one size available to work with all slat heights)

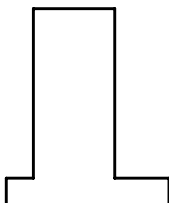

- End caps for exposed panel ends (multiple sizes available to work with specific slat heights)

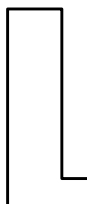

### 2.4 Acoustical Infill Panel Option

11" x 48" infill panels, item 6657, can be used for additional acoustics. They are slid on top of the WoodWorks Grille slats between two backers, but some field cutting of these infill panels will need to be done so that they fit properly at the ends of the panels.

24" x 24" infill panels, item 5823, should be used with dowel only panels.

## 3. INSTALLATION

Before starting any WoodWorks Grille ceiling installation, be sure to confirm any seismic requirements that may need to be met for your project.

### 3.1 NON-SEISMIC INSTALLATION

If WoodWorks Grille panels weigh in excess of 2.5 lbs/SF, the ceiling shall be installed per CISCA seismic zones 3-4, as modified by the IBC.

WoodWorks Grille slats install perpendicular to the main beams. The main beams shall be spaced 48" O.C. The 48" cross tees shall intersect the main beams at 90° every 24", creating a 24" x 48" module. Then 24" cross tees shall be installed parallel to the main beam creating a 24" x 24" module.

The suspension system must be leveled to within 1/4" in 10' and must be square to within 1/16" in 2'. Installation on suspension systems that do not meet this tolerance will produce unacceptable panel alignment.

WoodWorks Grille panels require two people to handle each panel safely, minimize damage, and provide panel support during installation.

See the last page of this document for a ceiling layout example.

### 3.2 Suspension System

Use Heavy-duty 15/16" Prelude® XL® T-Bar suspension system, main beams, cross tees, and wall molding to support the WoodWorks Grille panels.

**3.2.1** The suspension system is directional. Refer to the reflected ceiling plan to determine the suspension system layout. Main beams must run perpendicular to the panel length.

**3.2.2** Refer to the reflected ceiling plan for the finished height of the ceiling. Add the overall height of the WoodWorks Grille panel to determine the elevation of the suspension system. The WoodWorks Grille panel height and weight is listed on the data sheet.

**3.2.3** Install wall molding along the perimeter at the established suspension system elevation.

**3.2.4** Refer to the reflected ceiling plan to determine the panel orientation and size. Backers or dowels must be aligned with the main beams or cross tees. The first main beam should be no more than 12-1/2" off the wall and then 48" on center across the installation. For panels weighing less than 3 lbs/SF, use 12 gauge hanger wire 48" on center to support the main beams. For panels weighing greater than or equal to 3 lbs/SF, use 12 gauge hanger wire 36" on center to support the main beams. In addition to the above requirements, also follow ASTM C636 requirements.

**3.2.5** Install item XL7341 4' cross tees at 24" on center between the main beams. This will create a 24" x 48" suspension system module.

**3.2.6** Next, insert item XL8320 2' cross tees at the midpoints of the cross tees in Section 3.2.5. You should now have a 24" x 24" suspension system module. This is required to keep the WoodWorks® Grille panels perpendicular to the main beams and backers/dowels aligned along the suspension system for clip attachment.

**3.2.7** Additional cross tees can be installed in the system as needed to support mechanical fixtures such as lights and speakers.

**3.3 WoodWorks Grille Panel Installation**

**3.3.1** WoodWorks Grille panels are installed in sequence across the room. The first row of panels will have the male side towards the wall. Backer/dowel may need to be trimmed for proper panel alignment.

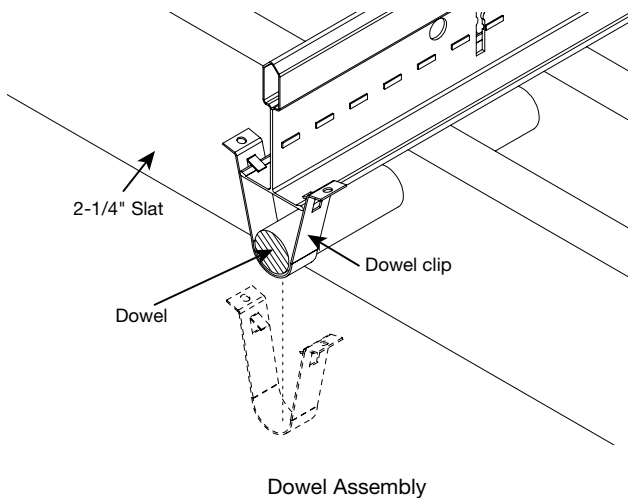
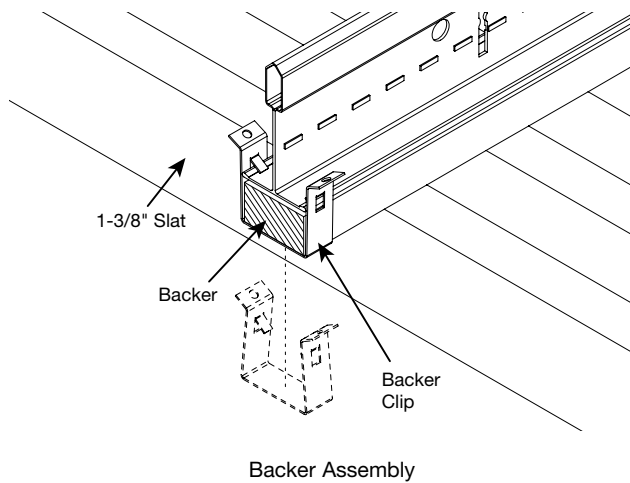

**3.3.2** The WoodWorks Grille panel is attached to the suspension system with a clip. Attach two clips on every hanging backer (backer that aligns with the suspension system). This should total 8 clips per full size panel.

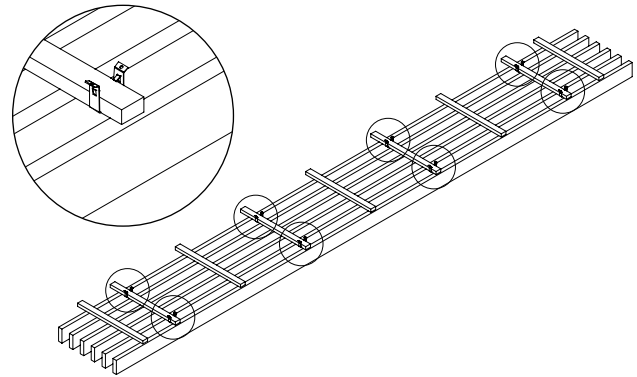

**3.3.3** Begin at one wall, raise the panel up against the suspension system, and align the backers/dowels with the suspension system.

Push upwards on the clip to engage the clip tabs onto the suspension system flange. Make sure both clip tabs engage the suspension system flange.

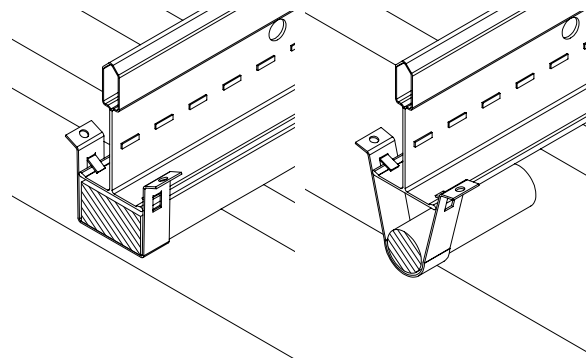

**3.3.4** Continue installing WoodWorks Grille panels — male to female — across the room.

**3.3.5** WoodWorks Grille panels with backers can be direct screw attached to the suspension system using standard #6 x 1-1/4" bugle head Hi-Lo drywall screws.

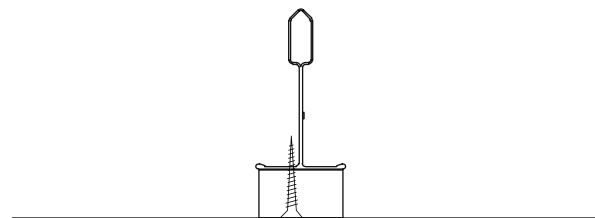

### 3.4 WoodWorks® Grille Reveal

3.4.1 WoodWorks Grille panels will have a 1" reveal between panel ends. This uniform spacing and alignment is maintained by the 15/16" suspension system assembly.

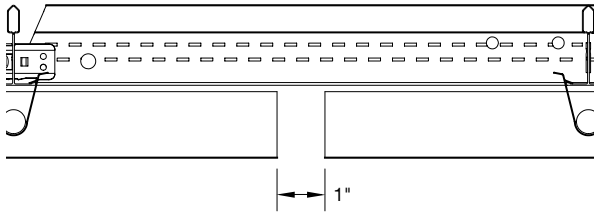

### 3.5 WoodWorks Grille Borders

3.5.1 Refer to the ceiling plan for border panel size and spacing.

3.5.2 The border where the panel ends meet the wall should have allowance for a 1" border in the ceiling plan.

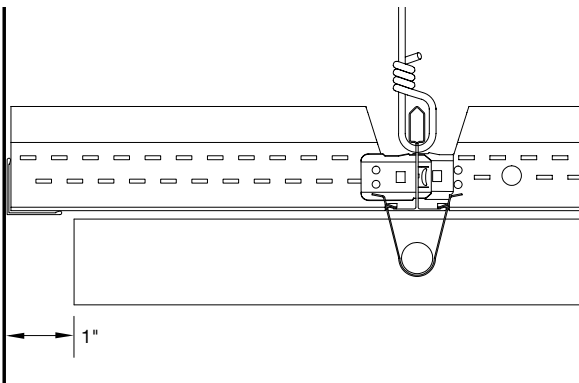

3.5.3 The border where panel sides meet the wall is determined by the first and last slat that is installed. These panels should be mechanically fastened in place to maintain the border.

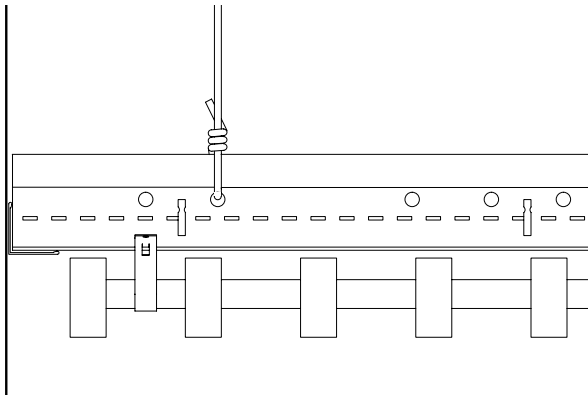

### 3.6 WoodWorks Grille Accessories

3.6.1 Ledger trim can be used to cover the wall molding with the same finish as the WoodWorks Grille panel. The ledger can be fastened to the molding with adhesive or screwed from above with 1/4" long screws.

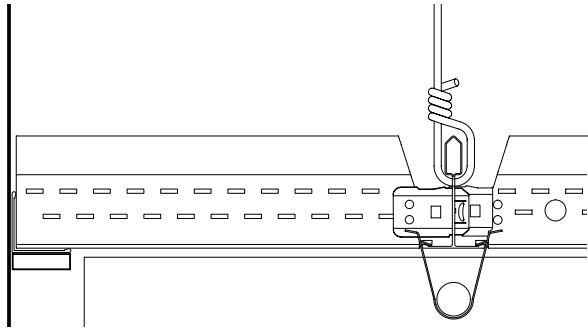

3.6.2 Junction trim can be used between WoodWorks Grille panels to fill the 1" reveal. This option will be specified on the ceiling plan. The junction trim must be installed progressively as the panels are installed. Install the first row of WoodWorks Grille panels. Place the shorter flange of the junction trim against the panel slats. Use 1-1/2" 4d finish nails every 16" to fasten the junction trim to the panel end. Install the next row of panels. The panel end will fit part way into the deeper side of the junction. This panel end will float free in the junction trim to allow for expansion and contraction of the WoodWorks Grille panels.

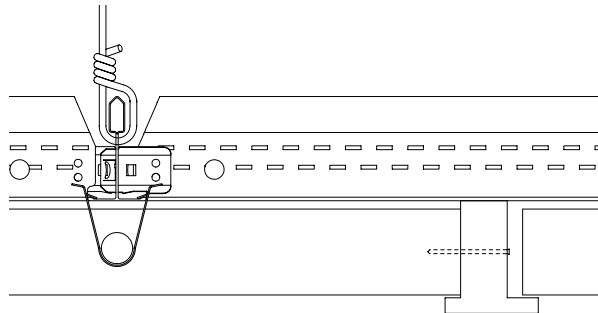

3.6.3 End caps can be used as trim for the panel end when the installation is not wall to wall, a floating cloud, or trim around a fixture. Cut the end cap trim to fit as required and use 1-1/4" 3d finish nails every 16" to fasten the end cap to the panel end.

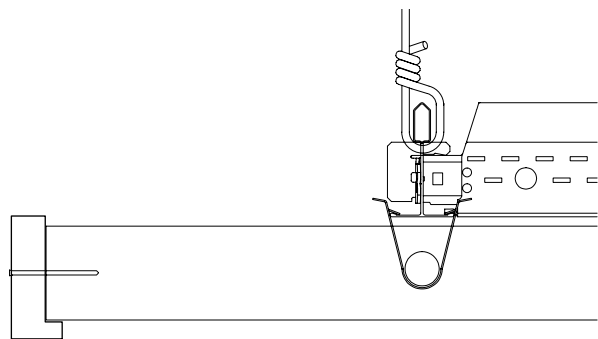

### 3.7 Mechanical Fixtures

**3.6.1** Mechanical fixtures such as lights, speakers, and sprinklers should be installed into the acoustical suspension system before installing the WoodWorks® Grille panels. Fixtures can be installed at the suspension system height or flush with the bottom of the panel. Fixture weight or housing must be supported by the acoustical suspension system. Install additional cross tees for support as needed. Refer to the ceiling plans for specific details. WoodWorks Grille panels can be cut to fit around fixture openings. Use the WoodWorks Grille end cap to trim the cut slats or sand and stain, or paint exposed field cut edges to match the panel finish.

### 3.8 Access Options

**3.8.1** To create an access door in the field: For a panel with backers, attach several pieces of 15/16" suspension system to the backer with standard #6 x 1-1/4" bugle head Hi-Lo drywall screws. For a panel with dowels, insert two clips at the four corners of the panel, then insert two clips on each dowel that align with the suspension system.

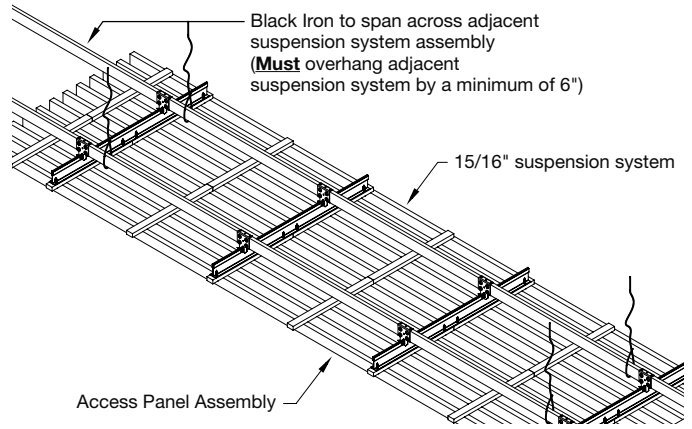

Shown on WoodWorks Backer

Additional hanger wire may be required on the adjacent suspension system. Channels must overhang adjacent suspension system by a minimum of 6".

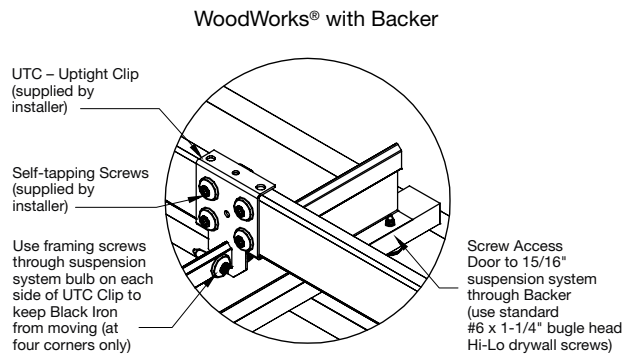

WoodWorks with Dowel

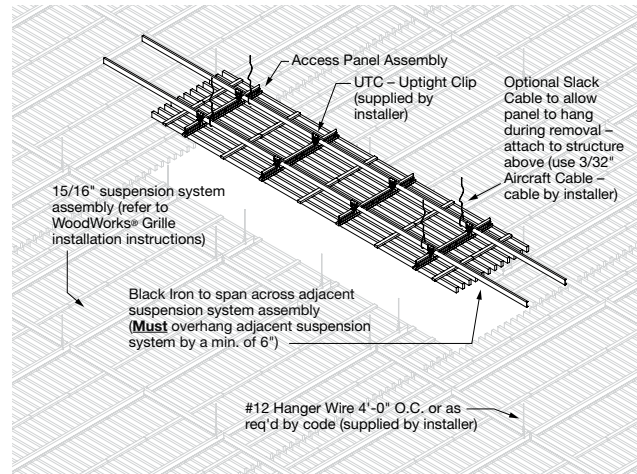
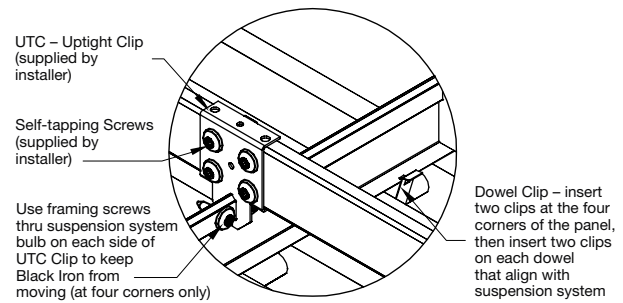

Shown on WoodWorks

Next, use two pieces of 1-1/2" channel to act as outriggers to support the access panel. These channels should be attached to the top of the suspension system with UTC clips. The weight of the access door will rest on the adjacent suspension system. Based on the weight of the WoodWorks Grille panels, access doors can be very heavy. We recommend extra support on the main beams and cross tee around the access door and using a minimum of two individuals to remove or lift the access doors.

## 4. WOODWORKS FACETED INSTALLATIONS

Only WoodWorks Grille panels with backers (not dowels) must be used for faceted installations

WoodWorks Grille panels can be installed to create a faceted ceiling vault or wall-to-ceiling transition. As the radius of the arc gets smaller, slat spacing between panels gets tighter. We recommend extra consideration when planning for faceted installations.

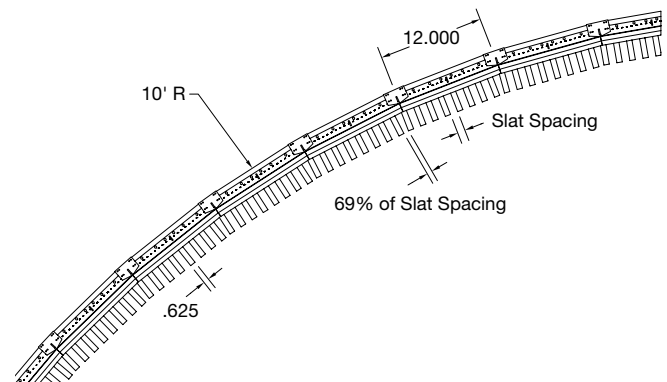

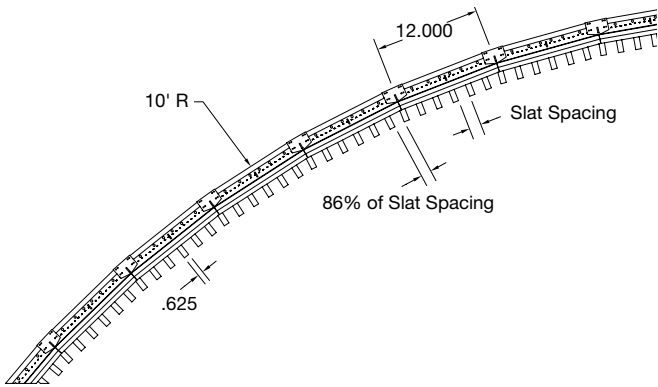

#### 4.1 Faceting a Main Beam

**4.1.1** To facet the main beam, field cuts must first be made to the suspension system.

Cut the bulb and web of the main beam at 12" intervals. Use every other cross tee route for reference.

**4.1.2** Use a curved template of the appropriate radius to hold the main beam in position as you attach RC2 clips.

**4.1.3** Bend the main beam at the field cuts and clamp it to the template.

**4.1.4** Position an RC2 radius clip over each cut in the main beam. Screw the RC2 clip over each cut with four #6 x 7/16" sharp point screws per clip — one screw at each corner.

For tips on creating a faceted curved suspension system, see the Drywall Grid Technical Guide, BPCS-3540. A copy is available on the web at [armstrong.com/drywall](http://armstrong.com/drywall).

#### 4.2 Faceted Suspension Systems

Faceted main beams are 24" on center and cross tees are 24" on center.

**4.2.1** Refer to the reflected ceiling plan and elevation view to determine the suspension system layout and height.

**4.2.2** Install wall molding along the perimeter at the determined suspension system elevation. **NOTE:** Molding along the curved side must be cut, faceted, and fastened to the wall to match the faceted main beams.

**4.2.3** Refer to the reflected ceiling plan to determine the panel orientation and size.

**4.2.4** Use 12 gauge hanger wire 48" or 36" (depending on weight of Grille panel lbs./SF) on center along the arc to support the main beams.

#### 4.3 WoodWorks® Grille Panel Faceted Installations

**4.3.1** All panels must be direct screw attached to every faceted main beam.

**4.3.2** Panel installation should start at the lowest point and work up to the highest point with the male end down.

**4.3.3** 12" long backers must be aligned with the 12" facet on the main beam. Two screws per backer into each main beam facet are required.

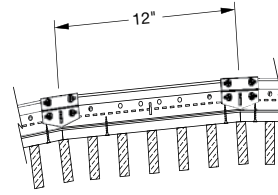

#### 4.4 WoodWorks Grille Accessories Faceted Installations

Use of WoodWorks Grille accessories for faceted installations is not recommended. When trim accessories are required, the installer must field miter, join, and attach the trim to exactly match the faceted panels.

#### 4.5 Wall Installations

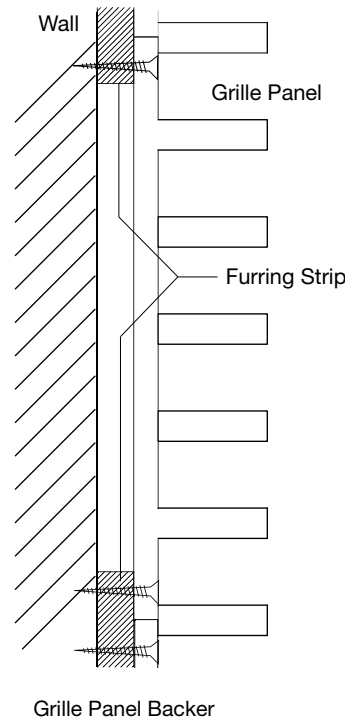

**4.5.1** Panel orientation can be horizontal or vertical.

**4.5.2** Furring should be attached to wall structure and then the WoodWorks® Grille should be attached to the furring. Pre-drill clearance hole in backer.

**4.5.3** Furring spacing – for backer panels, furring spacing is 12" O.C. The seam of the two panels should meet at the center of the furring.

**4.5.4** For panel attachment, use two screws per backer.

**4.5.5** WoodWorks Grille panels can be cut to fit receptacles or other wall fixtures. Use normal woodworking tools to achieve the desired opening. Attach backer (by others) for extra support as needed.

**4.5.6** Use the WoodWorks Grille end cap to trim cut slats or sand and stain, or paint exposed field cut edges to match the panel finish.

## 5. CUTTING

When you cut a panel to length, you can use normal woodworking tools, (e.g., circular saws, saber saws, coping saws, etc.).

Penetrations for sprinklers (or other fixtures) can be accomplished by simple interruption of the wood planks at those locations or by using normal woodworking tools to cut access in the planks.

**▲ CAUTION: WOOD DUST.** Sawing, sanding, and machining wood products can produce dust. Airborne wood dust can cause respiratory, eye, and skin irritation. The International Agency for Research on Cancer (IARC) has classified wood dust as a nasal carcinogen in humans.

**Precautionary measures:** If power tools are used, they should be equipped with a dust collector. If high dust levels are encountered, use an appropriate NIOSH-designed dust mask. Avoid dust contact with eyes and skin.

**First Aid measure in case of irritation:** In case of irritation, flush eyes or skin with water for at least 15 minutes.

## 6. SEISMIC INSTALLATION

WoodWorks® Grille systems have been engineered and tested for application in all seismic areas based on these installation procedures. The following installation guidelines are required in areas where anticipated seismic activity will be moderate to severe (IBC Seismic Design Categories C, D, E, and F). Consult the local building department to ensure compliance with their unique requirements.

### 6.1 Suspension System Installation

Use Heavy-duty 15/16" Prelude® XL® T-Bar suspension system, main beams, cross tees, and wall molding to support the WoodWorks Grille panels as listed in Section 3.1. The installation shall, in all cases, conform to the International Building Code Seismic Design Category D, E, and F. Refer to Armstrong Seismic Ceiling Installation Guide BPCS-4141 for more details on an IBC Design Category D installation.

Refer to the reflected ceiling plan to determine the panel orientation and size. Backers or dowels must be aligned with the main beams or cross tees. The first main beam should be no more than 12-1/2" off the wall and then 48" on center across the installation. For panels weighing less than 3 lbs/SF, use 12 gauge hanger wire 48" on center to support the main beams. For panels weighing greater than or equal to 3 lbs/SF, use 12 gauge hanger wire 36" on center to support the main beams. In addition to the above requirements, also follow ASTM C636 requirements. The requirements listed here represent the manufacturer's minimum acceptable installation recommendation, and may be subject to additional requirements established by the local authority having jurisdiction.

### 6.2 WoodWorks Grille Panel Installation

WoodWorks Grille panels must be mechanically secured to the suspension system for installations in IBC Seismic Design Categories C, D, E, and F.

#### 6.2.1 Option 1 – Direct Screw Attachment - Panels with Backer Only

This option is for WoodWorks Grille panels with backers only. Position the WoodWorks Grille panels on the suspension system and direct screw attach to the suspension system using standard #6 x 1-1/4" bugle head Hi-Lo drywall screws. See detail in Section 3.3.5. For best results, drill clearance holes in the backer to prevent splitting. Use two screws in each backer that aligns with the suspension system, typically eight fasteners per 8' panel. Panels are accessible with this option.

#### 6.2.2 Option 2 – Clip Attachment – Panels with Dowels Only

This option is for WoodWorks Grille panels with backers or dowels. Attach the panel to the suspension system as described in Section 3.3. with the appropriate clip. Next, use an 18 gauge wire tie to securely tie the clip to the suspension system. This is a progressive installation and the wire ties should be done in sequence for ease of installation.

- Bend an 10" to 12" piece of wire tie into a V
- Slip the wire over the suspension system and insert the wire ends into the holes of the clip
- Next, pull the wire ends up over the bulb of the suspension system and twist to secure the clip to the suspension system, a minimum of three turns
- Wire ties are required on a minimum of eight clips per 8' panel

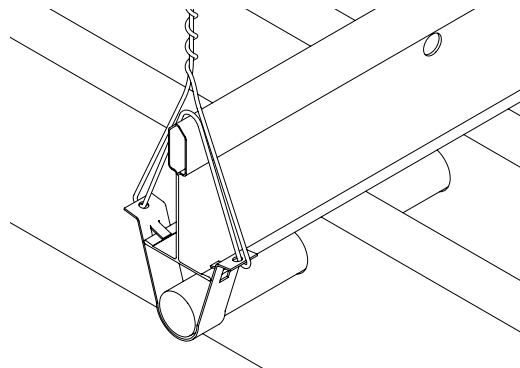

WoodWorks Grille panels installed with this option are not easily accessible.

Testing conducted at the Structural Engineering Earthquake Simulation Laboratory, located at the State University of New York – Buffalo campus, produced satisfactory results with the guidelines listed on page 8.

## 7. TYPICAL GRID PLAN

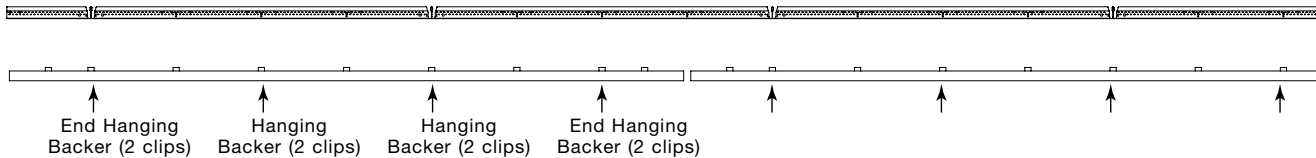
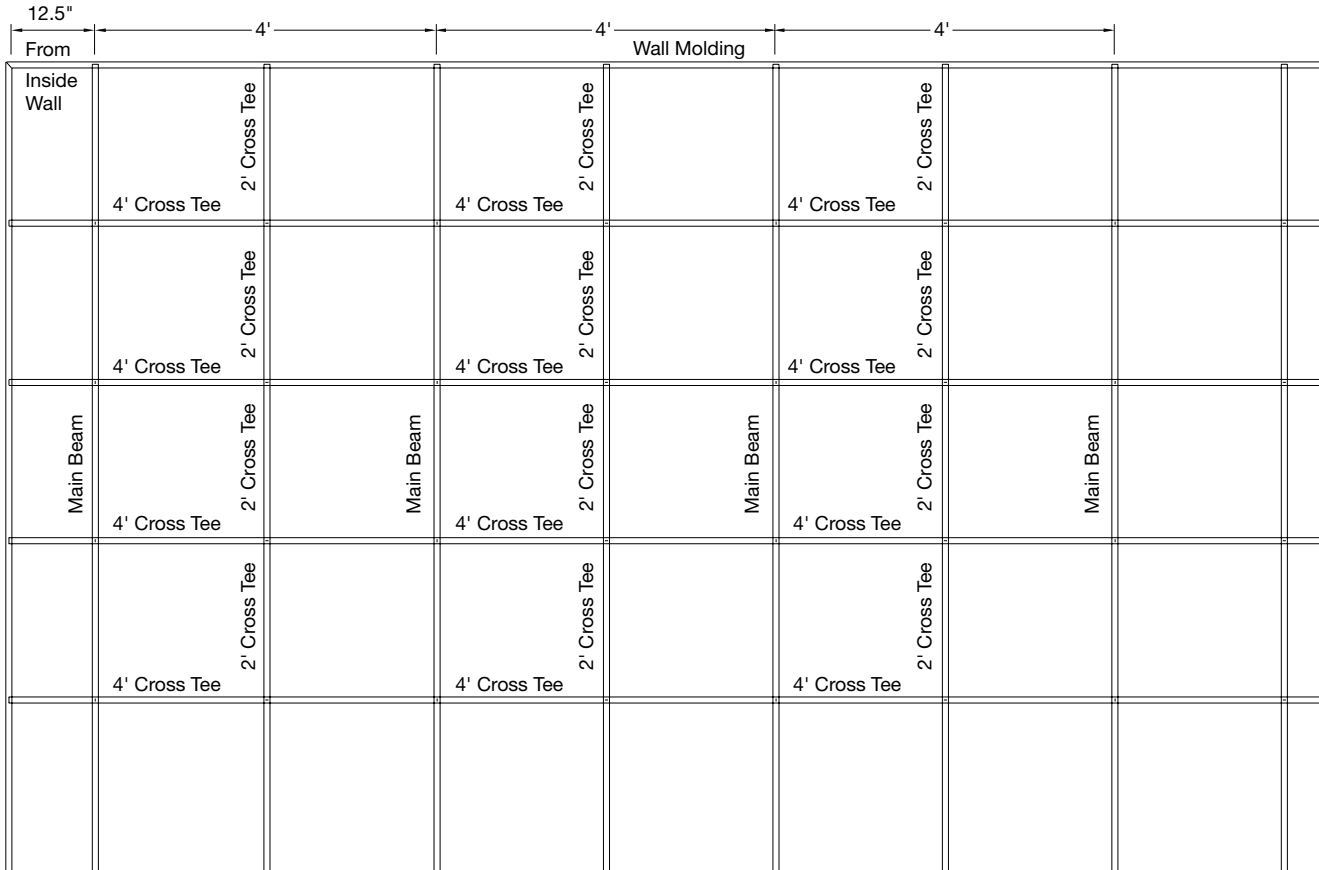

## 8. CLEANING RECOMMENDATIONS

There are three methods that we recommend for cleaning a WoodWorks Grille panel. First, the panels can be vacuumed to remove any dust or dirt that may accumulate on the slats or backers. Second, use a clean, dry, soft cloth to wipe off any dirt or greasy fingerprints. If this does not clean the panel, use a damp, clean, soft white cloth or sponge with a mild detergent to wipe the panel. Third, for scuff marks that may have transferred from the backers or dowels to the slats; use a clean, soft white cloth with either Naptha or Mineral Spirits to clean scuff marks on solid wood slats. We recommend wiping the slats with normal pressure, and do not recommend scrubbing the slats with the cloth.

### MORE INFORMATION

For more information, or for an Armstrong representative, call 1 877 ARMSTRONG.

For complete technical information, detail drawings, CAD design assistance, installation information, and many other technical services, call TechLine<sup>SM</sup> at 1 877 ARMSTRONG or FAX 1 800 572 TECH.

For the latest product selection and specification data, visit [armstrongceilings.com/woodworks](http://armstrongceilings.com/woodworks).

All trademarks used herein are the property of AWI Licensing LLC and/or its affiliates  
© 2017 AWI Licensing LLC • Printed in the United States of America

BPLA-297530-217

**Armstrong**<sup>®</sup>  
CEILING SOLUTIONS