

# apollo™ 8

FMA8 | FMA8D



FOCAL POINT®

## INDIVIDUAL

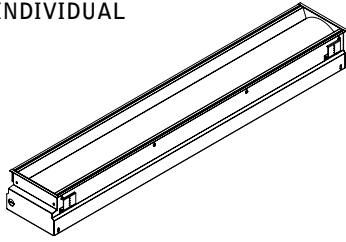

## TEE SPACING

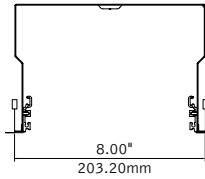

## LUMINAIRE WEIGHT

4' - 32LBS

## KEY

- POWER OFF
- POWER ON
- ATTENTION

## PATIENT BED PAIRS

SHIPPED 2 TO A BOX WITH  
1 ATTACHED WHIP

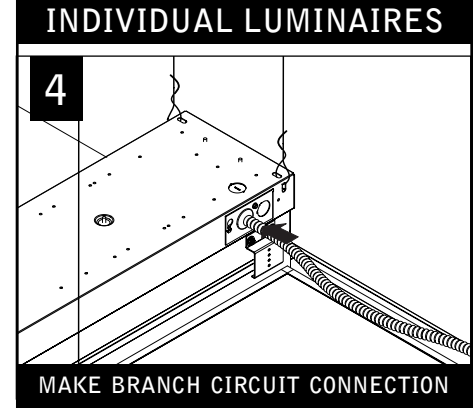
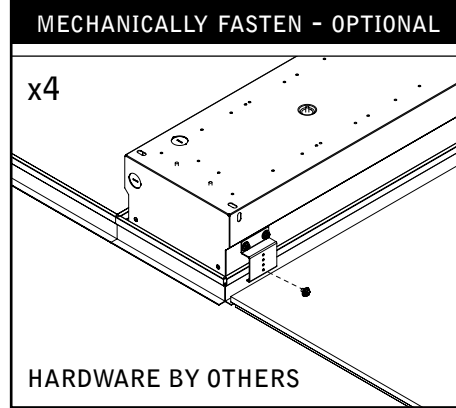
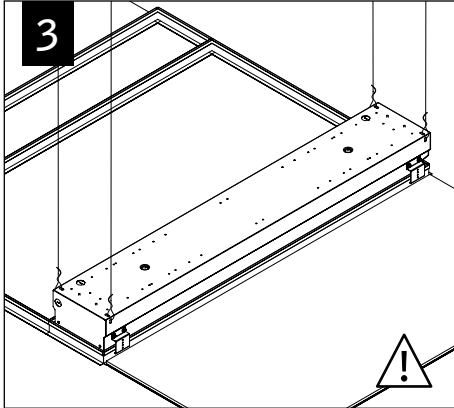
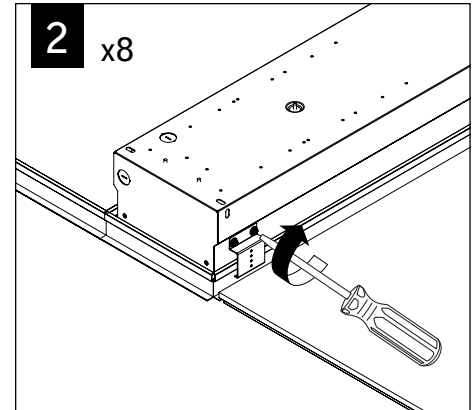
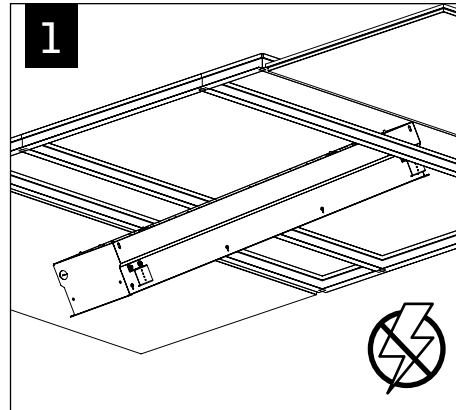
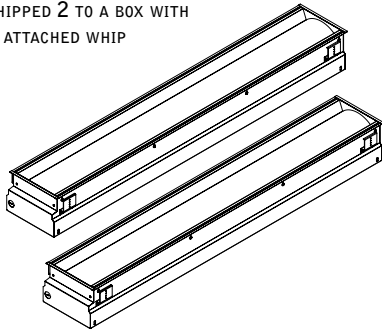

## PATIENT BED PAIRS

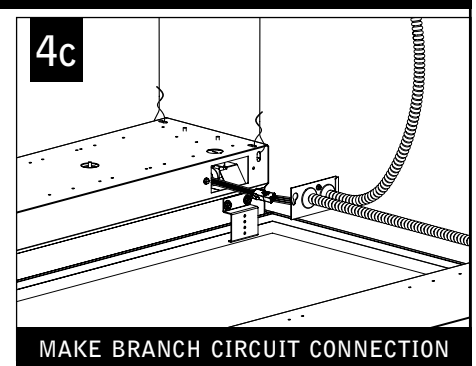
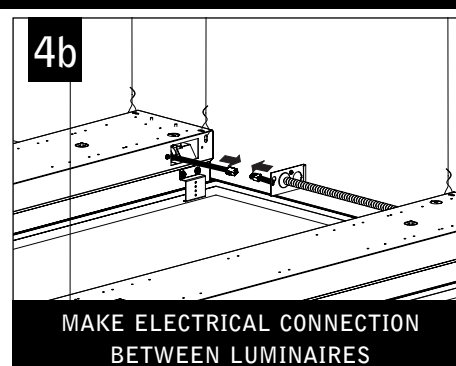
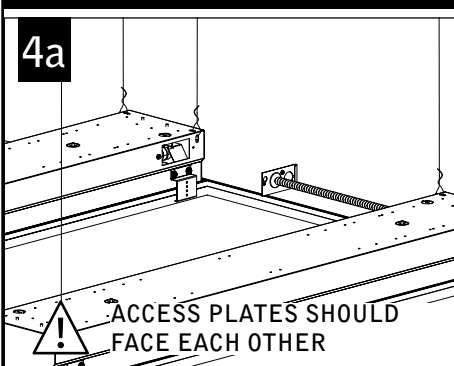

Luminaires must be installed by a qualified electrician (check with local and national codes for proper installation).  
To prevent electrical shock, disconnect electrical supply before installation or servicing.

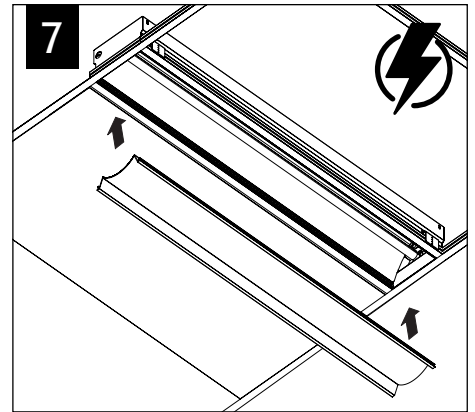
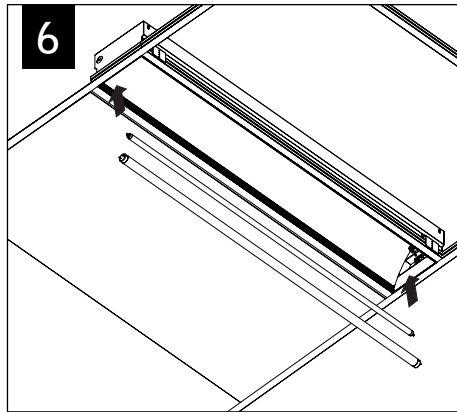
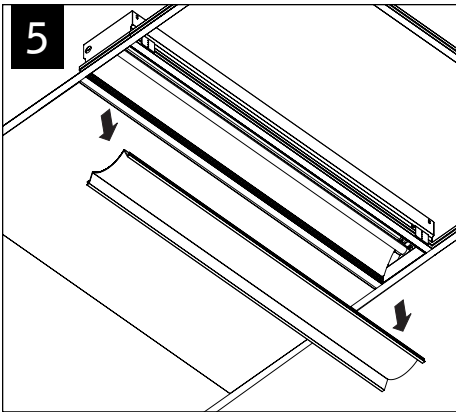

### BALLAST SERVICE

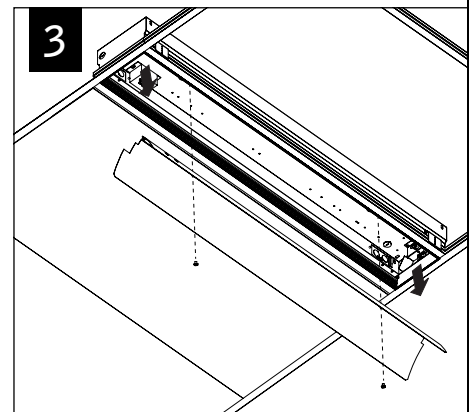
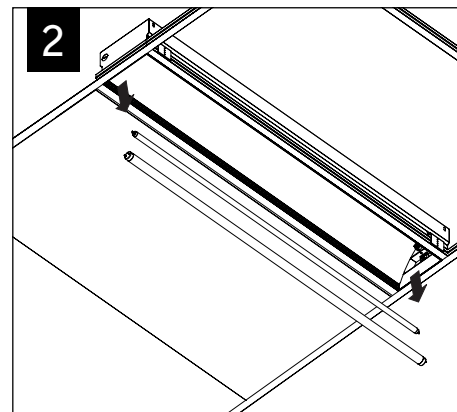
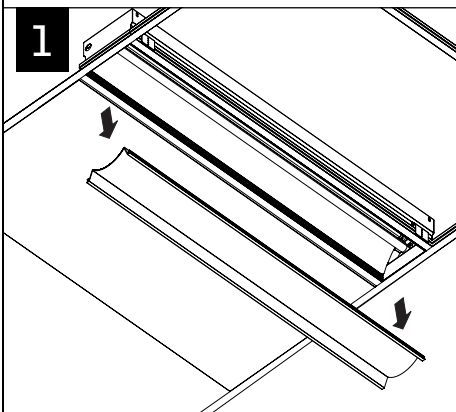

Contractor is responsible for adequately reinforcing walls and/or ceilings to support luminaire weight. Focal Point, LLC accepts no responsibility for inadequately reinforced walls and/or ceilings. The information contained in this drawing is the sole property of Focal Point, LLC. Any reproduction in part or whole without the written permission of Focal Point, LLC is prohibited.