

Graphlar

InterfaceFLOR®

Important notices

These Installation Instructions cover most installation procedures. If you run across a situation that isn't addressed in this document or requires more detailed assistance please contact the Interface Americas Help Desk at (877) 733-7403.

All carpet tiles should be carefully inspected for damage or defects prior to installation. InterfaceFLOR will not be responsible for any cost associated with replacement or repair as a result of damaged or defective tiles being installed which were identifiable prior to installation.

If you encounter any conditions or defects during installation which could jeopardize the installation or affect the installation procedure, you should STOP the installation immediately and call the Interface Americas Help Desk at (877) 733-7403. In Canada, call (800) 267-2149.

The carpet tiles are warranted in accordance with InterfaceFLOR's Standard Product Warranty. If you do not have a copy of InterfaceFLOR's Standard Product Warranty and wish to obtain one, call the Interface Americas Help Desk at (877) 733-7403. In Canada, call (800) 267-2149. **EXCEPT AS EXPRESSLY PROVIDED IN THE STANDARD PRODUCT WARRANTY, INTERFACEFLOR MAKES NO REPRESENTATIONS OR WARRANTIES, EXPRESS OR IMPLIED, INCLUDING, WITHOUT LIMITATION, ANY WARRANTY OF MERCHANTABILITY OR FITNESS OF ITS PRODUCTS FOR ANY PARTICULAR PURPOSES, AND HEREBY DISCLAIMS THE SAME.** Without limiting the foregoing, InterfaceFLOR will not be responsible for staining, soiling, contamination, tears, burns cuts, pulls or other damage, deterioration or loss caused by abuse, misuse, improper installation, improper maintenance

or failure to protect carpet tiles during building construction. InterfaceFLOR shall not be responsible for any damage or loss resulting from failure to strictly follow any part of these Installation Instructions, and such failure shall void any and all portions of the Standard Product Warranty which are affected by such failure.

WARNING: IN THE EVENT THAT ANY ASBESTOS-CONTAINING MATERIALS OR OTHER HAZARDOUS MATERIALS ARE ENCOUNTERED DURING INSTALLATION, YOU SHOULD STOP THE INSTALLATION IMMEDIATELY AND OBTAIN ASSISTANCE FROM A QUALIFIED REMEDIATION CONSULTANT OR CONTRACTOR PRIOR TO PROCEEDING.

Follow CRI installation standards

In addition to the specific floor preparation and installation instructions detailed here, the Carpet and Rug Institute Standard for Installation of Commercial Carpet (CRI 104) must be followed. Please note that many of the following installation requirements may exceed or differ from those in the CRI Standard. In the event of conflict between these Installation Instructions and the CRI Standard, you should follow these Installation Instructions.

Pre-installation visit

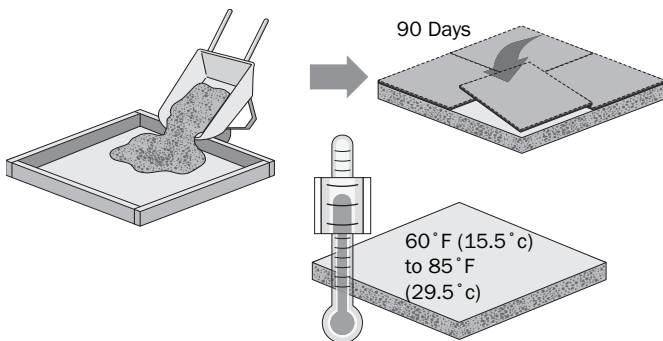

New concrete needs at least 90 days to fully cure. Lightweight concrete and concrete poured above grade in metal pans take a considerably longer time to cure. Installation cannot begin until it is fully cured and in compliance with moisture and alkalinity requirements.

The temperature of your job site must stay within 60°F (15.5°C) and 85°F (29.5°C) 48 - 72 hours prior to, during, and 48 - 72 hours after installation so be sure the heating and air conditioning system is operating.

All carpet tiles must be removed from the cartons and allowed to adjust to the job site temperature for 48 hours prior to installation.

Moisture and alkalinity test

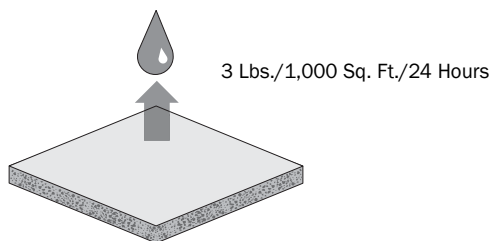

NOTE: Per CRI guidelines, it is recommended that the necessary pre-installation moisture and alkalinity tests be performed by a qualified independent testing consultant. These tests must be conducted to the ASTM guidelines.

InterfaceFLOR will not be responsible for failures, problems, or damage arising from high moisture, high alkalinity, or other subfloor conditions.

Before installing InterfaceFLOR Graphlar carpet tiles over a new or existing concrete subfloor, you must test the moisture and alkalinity levels of the concrete.

Moisture emissions should be determined by use of an Anhydrous Calcium Chloride test kit. The test must be administered to the specification of the ASTM F 1869 test procedure.

Moisture emissions must not exceed 3 pounds per 1,000 square feet for 24 hours. If the concrete test is higher than 3 pounds, do not proceed with the installation. Call the Interface Americas Help Desk at (877) 733-7403. In Canada, call (800) 267-2149.

Moisture and alkalinity test, continued

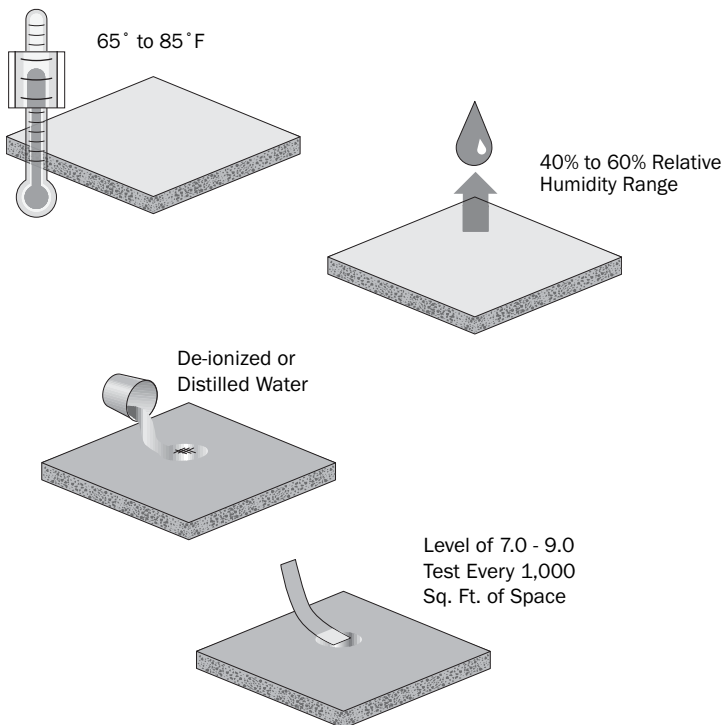

All concrete floors, old and new, should be tested for alkalinity by using an alkalinity test kit. The pH test papers should be capable of measuring a range of 0 -14. The area to be tested must be weather-tight and conditioned, via the building's HVAC system, to a temperature range of 65° - 85° Fahrenheit and a relative humidity range of 40% - 60%. This temperature and humidity range must be maintained for at least 48 hours immediately prior to commencing the test, and at all times during the test. All adhesives, coatings, finishes, dirt, curing compounds, sealant and other substances which may affect the rate of moisture dissipation must be removed from the area to be tested. Non-chemical methods, such as abrasive cleaning or bead blasting may be used on existing slabs to achieve an appropriate state for testing. Any cleaning should take place a minimum of 48 hours before testing.

Once this criteria has been met:

1. Abrade the surface by scratching into the clean slab a minimum of 1/32" but no more than 1/8".
2. Apply a small amount (approximately 1" in diameter) of de-ionized or distilled water.
3. Allow the de-ionized/distilled water to stand for 60 seconds.
4. Dip the 0-14 pH test strip into the puddle and remove immediately.
5. Compare to the test kits associated pH chart to determine the pH.
6. At least one pH test must be performed for every 1,000 square feet of space.

The slab should have an alkalinity level between 7.0 - 9.0 to be suitable for carpet installation. Should the pH level be outside of this range **STOP, and DO NOT proceed with installation.** Call the Interface Americas Help Desk at (877) 733-7403. In Canada, call (800) 267-2149.

NOTE: Test results reflect the condition of the slab at the time of testing.

InterfaceFLOR recommends the use of MoistureGard 2.0 prior to installation of the carpet when moisture and pH conditions are outside specified limits. MoistureGard 2.0 provides protection against moisture vapor emission rates of up to 15 lbs and pH up to 12. When MoistureGard 2.0 is used the carpet must be installed with InterfaceFLOR's TacTile system. Guidelines for the application of TacTiles can be found in this document. For more information on MoistureGard 2.0 contact your InterfaceFLOR Account Executive or call the Interface Americas Help Desk at (877) 733-7403.

Product inspection

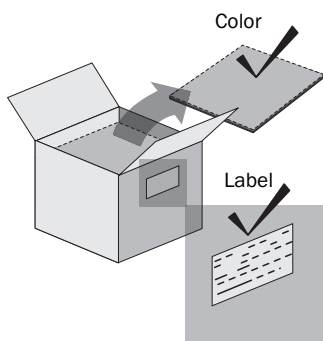

INSPECT INTERFACEFLOR GRAPHLAR CARPET TILES TO BE SURE THEY MEET THE ORDER SPECIFICATIONS. IF THE WRONG PRODUCT OR COLOR IS INSTALLED, INTERFACEFLOR WILL NOT BE RESPONSIBLE FOR CORRECTING THE PROBLEM.

The labels on each carton indicate product style, pattern, color, run number and dye lot. Be sure the style, pattern and color match the specifications for each area of your installation. On larger installations, you may find that some cartons have different run numbers and/or dye lots. Dye lots may be mixed for InterfaceFLOR i2™ styles. To avoid subtle variations in the finished installation of non-i2 styles, do not mix run numbers or dye lots in the same area.

Check to confirm that you have the right quantity and correct installation method. Be sure you also have enough tiles to establish an "attic stock" for future replacements.

Open all cartons to inspect for damaged or defective tiles. If you find any, call the Interface Americas Help Desk at (877) 733-7403. In Canada, call (800) 267-2149.

Lighting

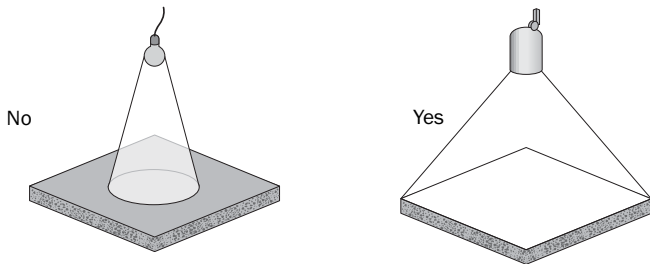

The lighting to be used by the building occupants must be in service for proper inspection of color and joints.

INSTALLATION OF CARPET TILES SHOULD BE THE LAST ITEM ON THE CONSTRUCTION SCHEDULE. CAREFULLY CONSIDER THE RISKS IF YOU ARE ASKED TO INSTALL CARPET TILES TOO EARLY. IF CARPET TILES ARE INSTALLED BEFORE CONSTRUCTION IS COMPLETE, ANY STAINING, SOILING OR DAMAGE CAUSED BY OTHER TRADES MAY VOID THE PRODUCT WARRANTY.

Monolithic installation

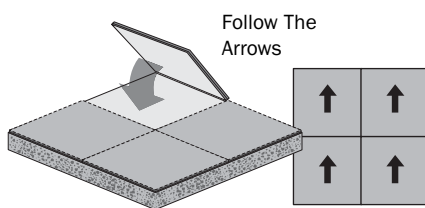

An arrow is printed on the back of each carpet tile to indicate pile direction. Make sure the arrows point in the same direction throughout your installation.

Quarter-turn installation

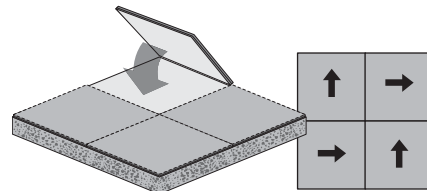

Some InterfaceFLOR Graphlar tiles are designed to be installed in a parquet pattern. In this case, the arrows should be turned 90 degrees every other tile.

Ashlar installation

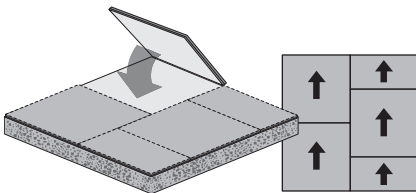

Some InterfaceFLOR Graphlar tiles are designed to be installed in an ashlar pattern by offsetting the front and back tile joints.

Non Directional installation

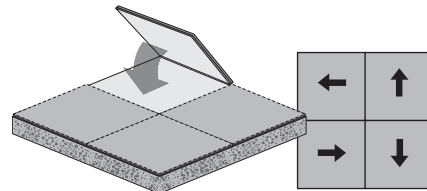

Some InterfaceFLOR Graphlar tiles are designed to be installed in a non directional pattern. This pattern allows installation of tiles without regard to arrow direction.

Brick installation

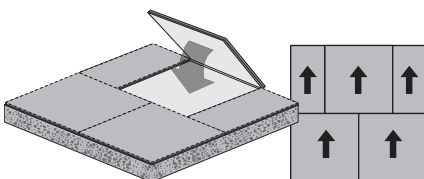

Some InterfaceFLOR Graphlar tiles are designed to be installed in a brick pattern by offsetting the side joints of the tiles.

Tools

Proper installation requires tools on the following checklist.

- English/metric steel measuring tape
- White chalk line
- Carpet knife
- Carpet knife replacement blades
- Steel straight edge
- Carpenter's square
- Broom
- Sander
- Vacuum
- Hammer
- Scraper
- TacTiles and Tactile Dispenser OR
- Recommended adhesive with 3/4" nap paint roller

Preparing the subfloor

Installing over concrete

Level

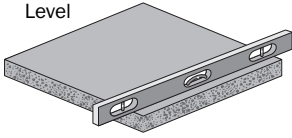

All concrete floors must comply with moisture and alkalinity requirements prior to proceeding with installation. (See "Moisture and Alkalinity Test" above.)

Level the floor to the standards outlined in the American Concrete Institute specifications for Concrete Building (ACI 301) – 11.7.3 troweled finish and 11.9.1 finishing tolerances. Leveling compounds must be Portland-based cement.

Patch Compound

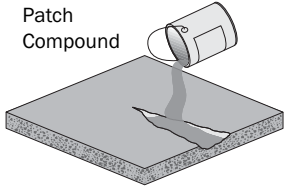

Sand

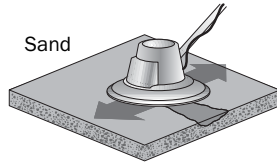

Patch cracks and holes with one of the following approved patching compounds: Lev-L-Astic, Fixall, Armstrong 5-180, Webpatch or Ardex K-15. Note that some patching compounds can be mixed with water while some must be mixed with latex. Follow the manufacturer's specification and instructions for use.

After patched areas have dried, sand all patched areas level.

Barrier Coat

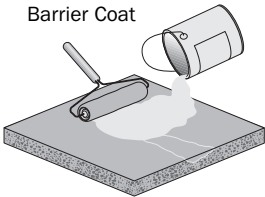

Use an appropriate cleaner to remove any dirt, grease, oil, paint, sealer, adhesive or other materials from floor. Make sure no cleaner residue remains after cleaning.

For enhanced performance, we recommend the use of an approved sealer such as XL Brands Primer Barrier Coat. With a roller, apply XL Brands Primer Barrier Coat.

Installing over wood, plywood or particle board

Repair

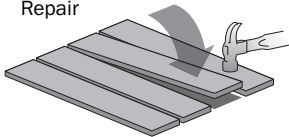

Repair loose or broken boards. Secure with 8-D cement-coated screw nails.

Plywood

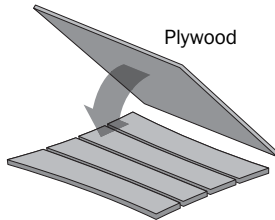

Nails
6" Apart

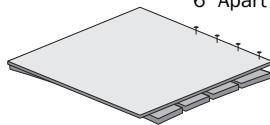

If the majority of the boards are worn or badly cupped, cover with 5/8 inch (1.6 cm) exterior grade AD plywood secured with 8-D cement-coated screw nails spaced 6 inches (15.2 cm) apart. Sand seams smooth.

Sand

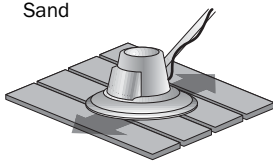

Barrier Coat

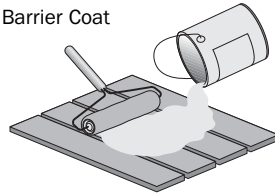

Sand the finish down to bare wood.

Remove dust by sweeping, then wiping with a tack cloth.

With a roller apply XL Brands Primer Barrier Coat over the entire surface.

Installing over vinyl tile, sheet vinyl or natural materials

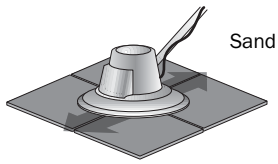

WARNING: EXISTING FLOOR COVERING MAY CONTAIN ASBESTOS OR OTHER HAZARDOUS MATERIALS. IN THE EVENT ASBESTOS CONTAINING MATERIALS OR OTHER HAZARDOUS MATERIALS ARE ENCOUNTERED, YOU SHOULD STOP THE INSTALLATION IMMEDIATELY AND OBTAIN ASSISTANCE FROM A QUALIFIED REMEDIATION CONSULTANT OR CONTRACTOR PRIOR TO PROCEEDING.

Use an appropriate stripper or a sander to remove the wax top coat.



Remove all vinyl tiles with a scraper or replace damaged tiles with substitute tiles of the same thickness. With a roller apply XL Brands Primer Barrier Coat over the entire surface.

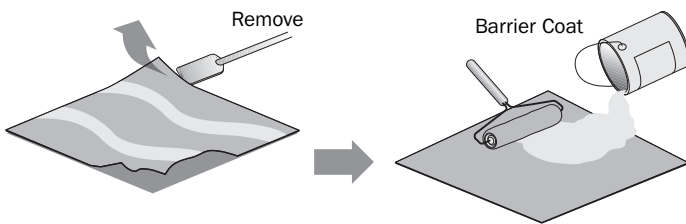

Remove sheet vinyl with a scraper. With a roller apply XL Brands Primer Barrier Coat over the entire surface.

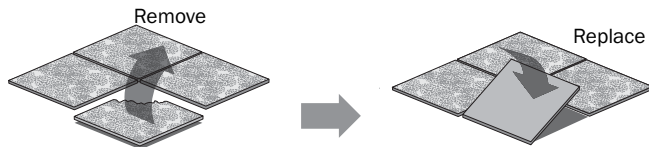

For natural materials such as granolithic, terrazzo, marble, ceramic tile, etc., breakout and remove all material or replace damaged areas with substitute material of the same thickness.

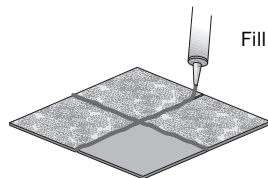

Patch and fill cracks and irregularities, including grout lines, with one of the following approved patching compounds: Lev-L-Astic, Fixall, Armstrong 5-180, Webpatch or Ardex K-15. Note that some patching compounds can be mixed with water while some must be mixed with latex. Follow the manufacturer's specification and instructions for use.

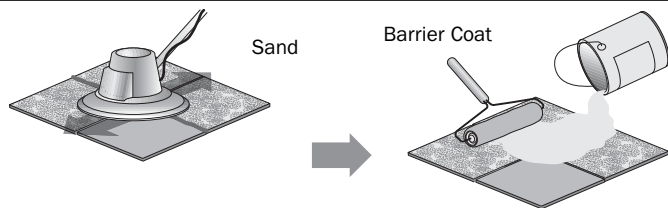

Sand top surface to remove glaze.

Remove dust by sweeping, then wiping with a tack cloth.

Apply XL Brands Primer Barrier Coat over the entire surface.

Installing over raised floors

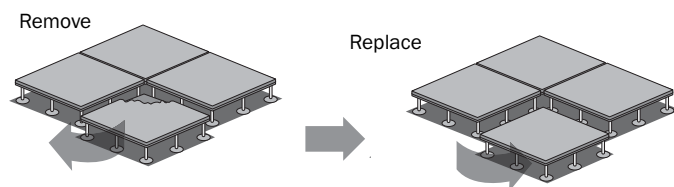

Patch or replace any damaged floor panel inserts.

Use an appropriate cleaner to remove any dirt, grease, oil, paint, sealer, adhesive or other materials from floor.

Establishing the starting point

Snap a Line

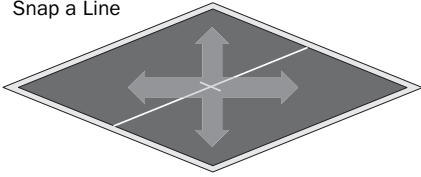

Measure to determine the center point and mark. Snap a chalk line.

Measure

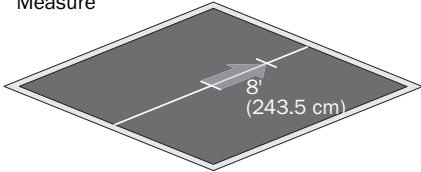

Measure 8 feet (243.5 cm) out from your center point along the chalk line. Make a mark.

Measure

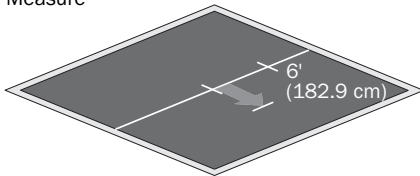

Measure 6 feet (182.9 cm) from your center point at a right angle to your chalk line and make a mark.

Measure

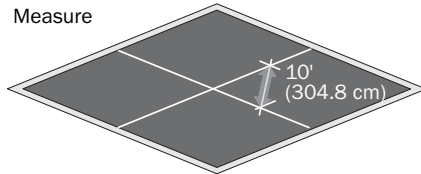

Measure the distance between your marks. It should be exactly 10 feet (304.8 cm). If it is, your quadrants will be square. Snap a chalk line here.

NOTE: If the room is too small for the above measurements, reduce them in half. Measure 4 feet (121.9 cm) vertically and 3 feet (91.4 cm) horizontally. In this case, the measurement between your two marks should be exactly 5 feet (152.4 cm).

Determine if center lines need to be offset

Dry fit (without adhesive) a row of tiles along the entire length of your vertical and horizontal center lines. Go all the way to the walls. If necessary, offset either or both center lines to ensure perimeter tiles will be cut no less than half size, or 9.84 inches (25 cm).

Applying TacTiles for Graphlar

NOTE: Be sure that you're using the correct type of TacTile. ONLY TacTiles for Graphlar should be used with Graphlar backing.

The average TacTile application rate is 4 TacTiles per square yard of carpet. In small spaces a higher per yard application rate may apply. Consult your local Account Executive or the Interface Americas Help Desk at (877) 733-7403 for assistance.

TacTiles should not be used on stairs, ramps or inclines

Lay anchor rows, placing a TacTile at every joint. Install carpet using a step method placing a TacTile at every corner.

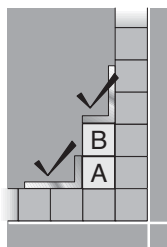

Check Square

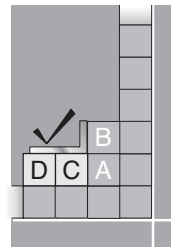

Check Square

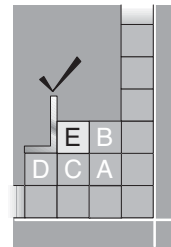

Check Square

TacTile Placement

Insert tiles based on approved installation method. TacTiles should be applied based on the following diagrams.

Quarter-Turn / Monolithic / Non-Directional Installations / Area Rugs

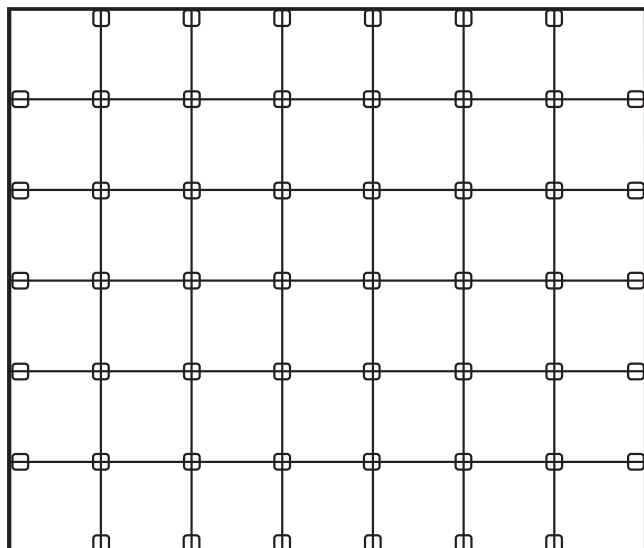

Brick / Ashlar Installations

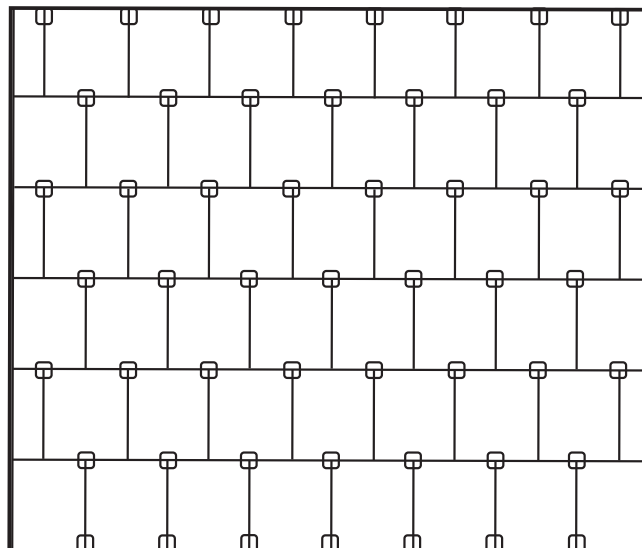

Applying adhesive

Use only Re:Source 2000 Pressure Sensitive Adhesive on all areas other than stairs. In Canada, use only Re:Source 2500 Pressure Sensitive Adhesive on all areas other than stairs.

On stairs, use only vinyl compatible permanent adhesive. For stair nosing, use manufacturer's recommended installation method.

Full spread adhesive application

Spread Rate:
40 to 45 Sq. Yds./Gallon

Apply adhesive with a 3/4" nap paint roller. Expect a spread rate of 40-45 square yards per gallon using a 3/4" nap paint roller.

For raised floor systems a full spread of adhesive is required.

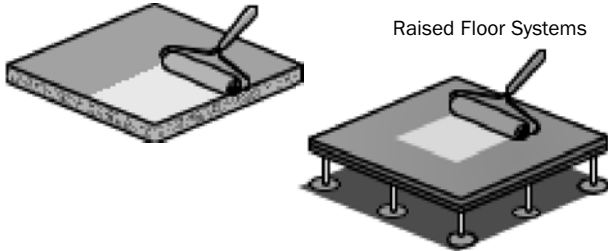

Grid adhesive application

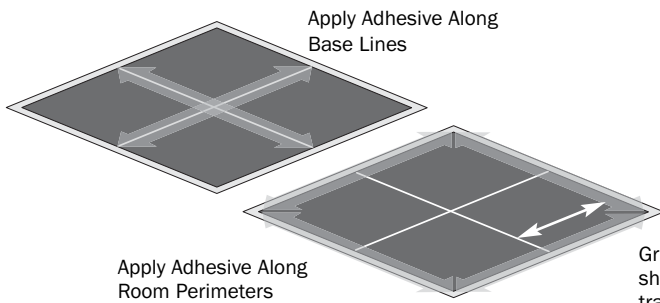

Using a 3/4" nap paint roller, apply adhesive along each base line to anchor the starting rows.

Adhesive must also be applied at all room perimeters (each wall).

The application rate for a grid adhesive method is 180 square yards per gallon.

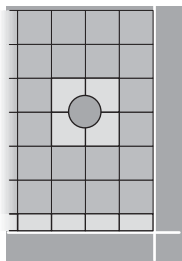

NOTE: A full spread of adhesive must be applied under every cut tile and any adjoining tile to the cut tile. Full spread is also required in any area that will be exposed to high foot traffic and/or heavy rolling traffic.

Adhesive in special situations

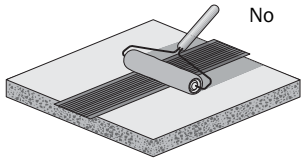

Flatwire

Never apply adhesive directly over flatwire. The flatwire may be damaged if the tiles need to be removed.

Uneven areas

Any surface that cannot be leveled may require adhesive or double-sided tape to hold a tile in place.

Laying tiles

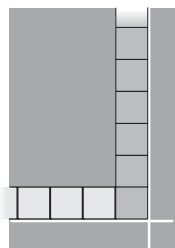

3mm or 1/8" Gain

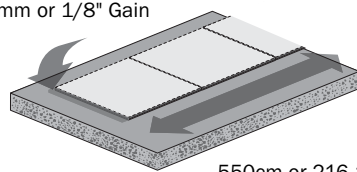

550cm or 216 17/32"

Follow the center lines closely. In smaller rooms, your anchor rows may consist of fewer than 11 tiles. Lay an anchor row of 10 additional tiles (11 including the one you've already placed) aligned with the center line.

Measure your anchor rows. Each should equal 550 cm (11 tiles x 50 cm each, or 216 17/32") with no more than a 3mm (1/8") gain. If the gain is more than 3 mm, the tiles aren't tight enough and should be laid again. After relaying, measure again. If tiles are less than 550 cm they are too tight and should be layed again.

Tip into place

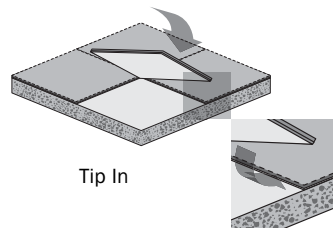
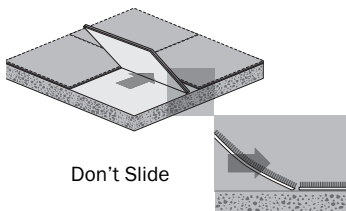

Don't position tiles by sliding them across the adhesive. This will cause the corner to bend under. Instead, brush the pile back with one hand, then tip a corner of the tile into place. Position the rest of the tile once the corner is properly aligned. Do not catch the pile in the joints.

Lay tiles in step or pyramid pattern

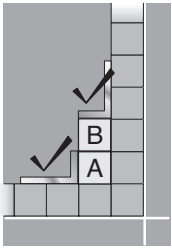

Check
Square

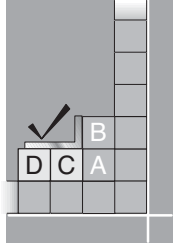

Check
Square

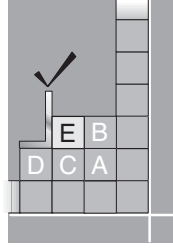

Check
Square

1. Lay two tiles vertically, and check that they are square to the anchor rows.
2. Lay two tiles horizontally, and check that they are square to the anchor rows.
3. Lay one tile to complete the step.

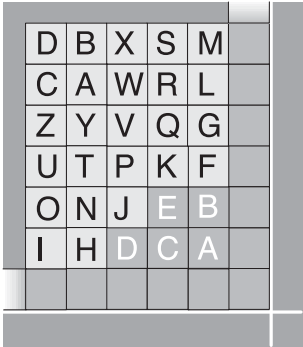

4. Follow the ABCD pattern laid out here until you reach the end of your anchor rows. Repeat laying anchor rows and ABCD patterns in all quadrants until complete.

Cutting tiles

Guidelines for cutting tiles

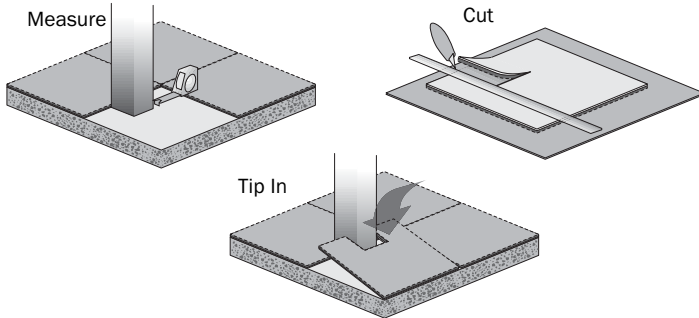

Tiles adjacent to fixtures, architectural elements and walls need to be cut. Follow these guidelines:

- If practical, remove the base molding before installing perimeter tiles. Replace molding when finished.
- Replace blades often. Sharp blades make cutting quicker, easier and more precise.
- Never use other tiles as a cutting surface. Place tiles on layers of cardboard before cutting.
- Always secure cut tiles with adhesive.

Floor outlets

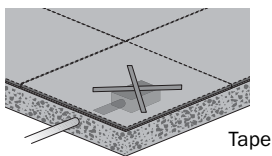

Floor outlets are usually wired after carpet tiles have been installed. Consequently, you should install tiles directly over floor outlets and mark the location with tape. This way, it will be easy to see which tiles need to be lifted for cutouts later.

Flatwire

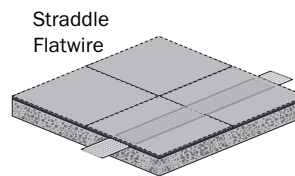

Tile layout should allow flatwire to be centered under a row of tile.

Trench headers

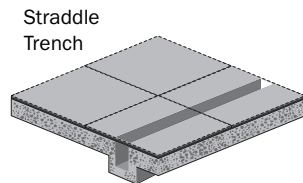

Tile layout should allow trench headers to be centered under a row of tile. Secure the tiles on either side of trench headers with adhesive. This will prevent the installation from shifting while servicing trench headers.

Raised floors

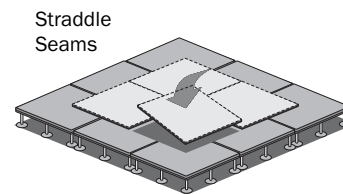

Raised floor panels are susceptible to subtle flexing. To ensure uniform appearance, avoid matching raised floor seams with tile joints.

Preparing for occupation

Final inspection and vacuum

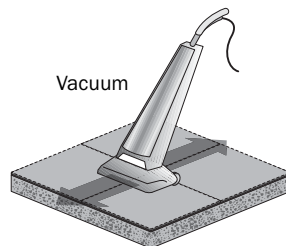
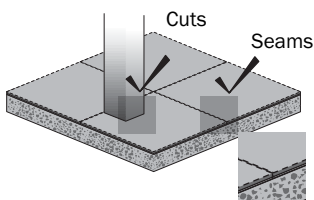

Inspect the entire installation, paying close attention to joints and any tiles that have been cut.

Vacuum the floor with a pile lifter. If you don't have a pile lifter, use an upright vacuum cleaner.