

Installation Instructions

Please read all instructions before installing corner guard.

High Impact End Wall Protectors

Models: 150D, 160D, G2-150D, G2-160D

Important

1. Acclimate materials 24 hrs before installation. Maintain temperature controlled environment after installation
2. Install in accordance with manufacturer's installation instructions. Failure to do so will void the warranty.

Installation tips

1. Cut covers up to 1/16" (1.6mm) longer to ensure a tight fit.

Section View

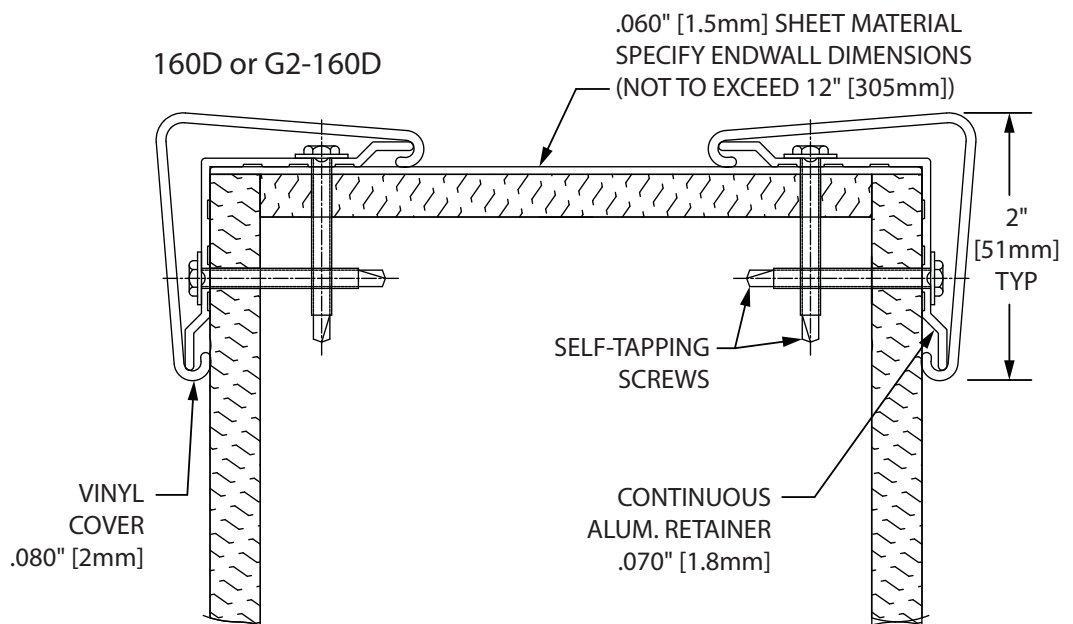
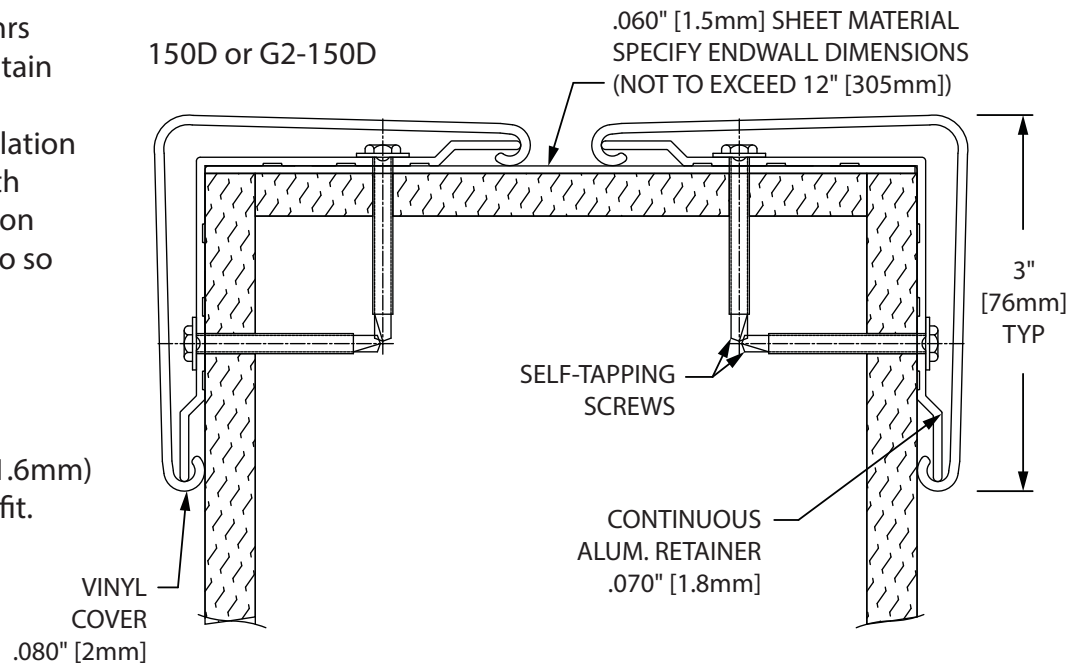

Recommended tools

Safety Glasses, Tape Measure, Level, Power Drill, 1/4" Socket, Drill Bits - 1/4" masonry (concrete/concrete block), Power Miter Saw, 10" Blade with 60-80 Carbide Tipped Teeth

IPC.401/REV.9

Installation Hotline • 866.EZINPRO
Inprocorp.com • 800.222.5556 • 262.679.9010

World Headquarters S80 W18766 Apollo Drive, Muskego, WI 53150 USA

IPC® •
DOOR + WALL PROTECTION SYSTEMS
A DIVISION OF INPRO®

Installation Instructions

Please read all instructions before installing corner guard.

High Impact End Wall Protectors

Models: 150D, 160D, G2-150D, G2-160D

Components and Fasteners

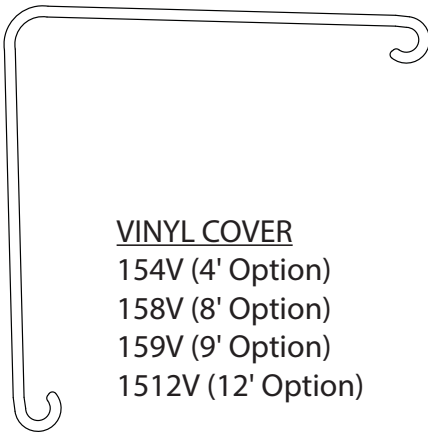

VINYL COVER
 154V (4' Option)
 158V (8' Option)
 159V (9' Option)
 1512V (12' Option)

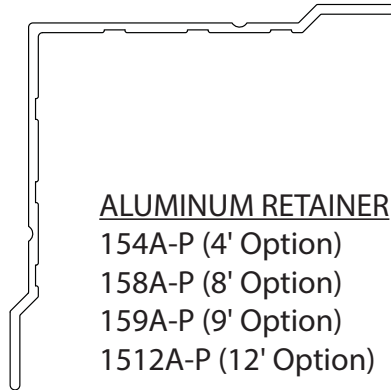

ALUMINUM RETAINER
 154A-P (4' Option)
 158A-P (8' Option)
 159A-P (9' Option)
 1512A-P (12' Option)

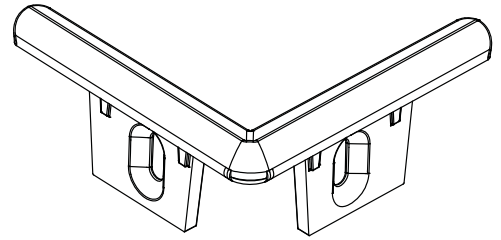

151TC
 TOP/BOTTOM CAP



.060" [1.5mm]
 RIGID SHEET MATERIAL

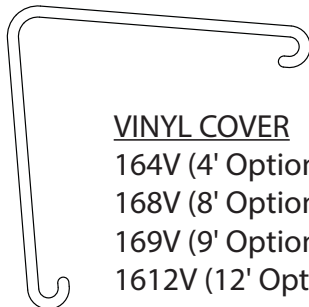

VINYL COVER
 164V (4' Option)
 168V (8' Option)
 169V (9' Option)
 1612V (12' Option)

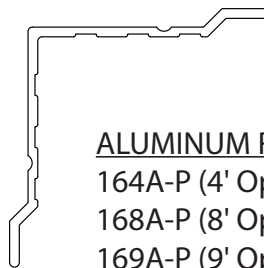

ALUMINUM RETAINER
 164A-P (4' Option)
 168A-P (8' Option)
 169A-P (9' Option)
 1612A-P (12' Option)

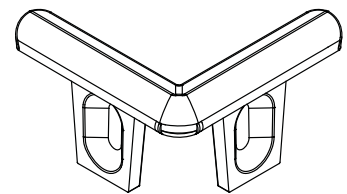

161TC
 TOP/BOTTOM CAP

Condition	Specified Fasteners	Inpro Part #
Drywall/Wood	#8 x 1 1/2" Phillips Indented Hex Self-Drilling Screw #8 x 1 1/4" Phillips Flat Head Self-Tapping Screw	HWK-HIGC4DW (4') HWK-HIGC8DW (8') HWK-HIGC9DW (9'-12')
Concrete	#10 1 3/4" Phillips Pan Head Sheet Metal Screw #8 x 1 1/2" Phillips Flat Head Sheet Meat Screw 1/4" Plastic Alligator Anchor	HWK-HIGC4C (4') HWK-HIGC8C (8') HWK-HIGC9C (9'-12')

Installation Hotline • 866.EZINPRO
 Inprocorp.com • 800.222.5556 • 262.679.9010
 World Headquarters S80 W18766 Apollo Drive, Muskego, WI 53150 USA

IPC® •
 DOOR + WALL PROTECTION SYSTEMS
 A DIVISION OF INPRO®

Installation Instructions

High Impact End Wall Protectors

Models: 150D, 160D, G2-150D, G2-160D

Please read all instructions before installing corner guard.

Exploded Assembly View

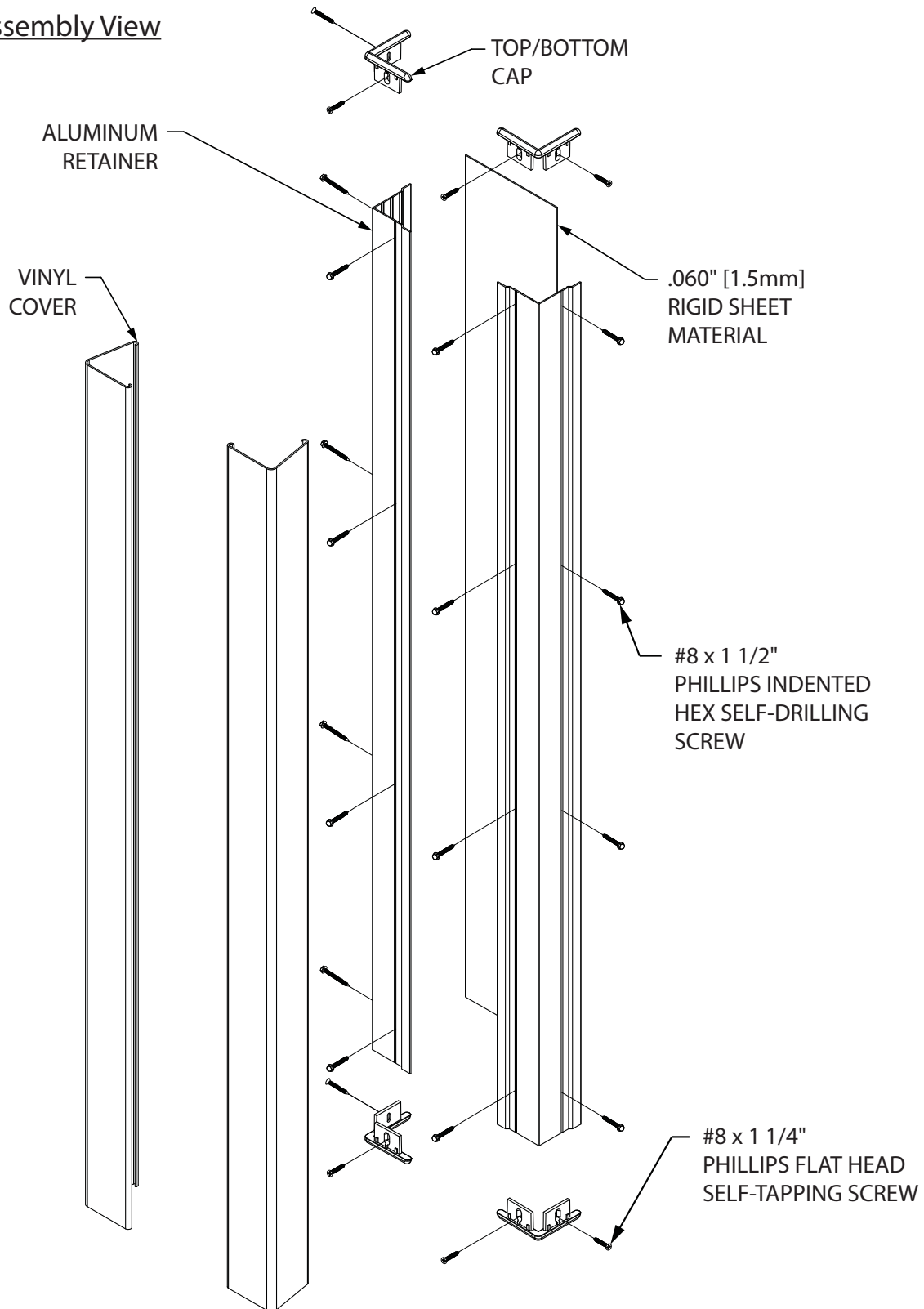

Installation Hotline • 866.EZINPRO

Inprocorp.com • 800.222.5556 • 262.679.9010

World Headquarters S80 W18766 Apollo Drive, Muskego, WI 53150 USA

IPC •

DOOR + WALL PROTECTION SYSTEMS
A DIVISION OF INPRO®

Installation Instructions

High Impact End Wall Protectors

Models: 150D, 160D, G2-150D, G2-160D

Please read all instructions before installing corner guard.

FIG. 1

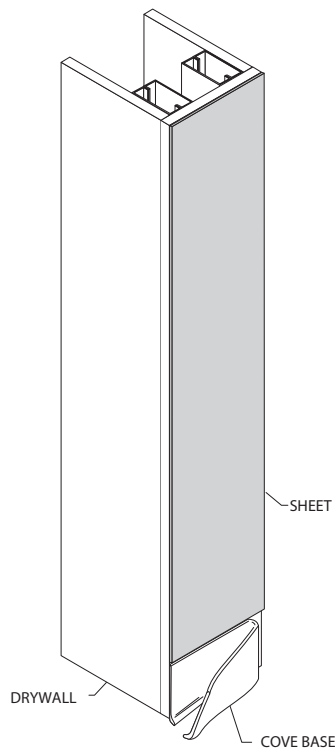

1. Adhere sheet material to wall with factory applied adhesive backing or recommended IPC adhesive (Fastbond 30 Contact Cement, XT-2000 Adhesive, InPro Bond Adhesive). SEE FIG. 1

2. Position aluminum retainer against wall, leaving allowance for bottom cap. Secure retainer to the wall using the pre-slotted holes on the retainer. SEE FIG. 2

Note: For concrete installation, use the slotted tabs on the top and bottom caps to transfer and drill 1/4" (6.5mm) holes into the ends of the retainer. Transfer the location of all mounting holes to the wall. Drill marked holes on wall using a 1/4" (6mm) drill bit and position Alligator anchors into holes. Mount retainer on wall with #10 x 1 3/4" phillips pan head screws and tighten to secure.

FIG. 2

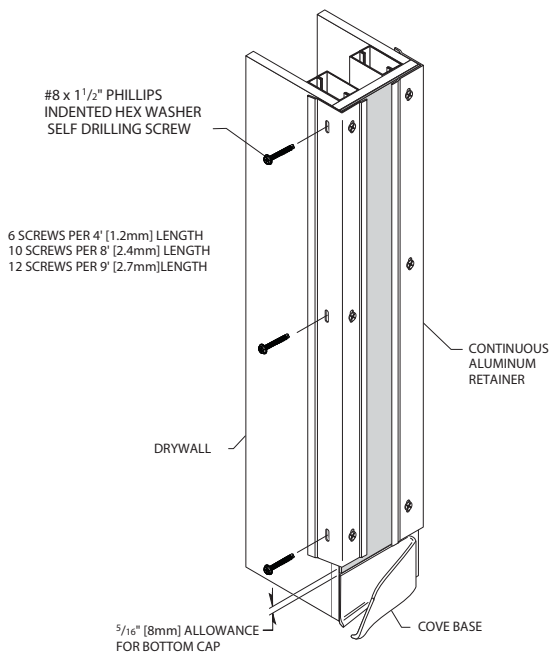

Installation Hotline • 866.EZINPRO

Inprocorp.com • 800.222.5556 • 262.679.9010

World Headquarters S80 W18766 Apollo Drive, Muskego, WI 53150 USA

IPC®

DOOR + WALL PROTECTION SYSTEMS
A DIVISION OF INPRO®

Installation Instructions

High Impact End Wall Protectors

Models: 150D, 160D, G2-150D, G2-160D

Please read all instructions before installing corner guard.

FIG. 3

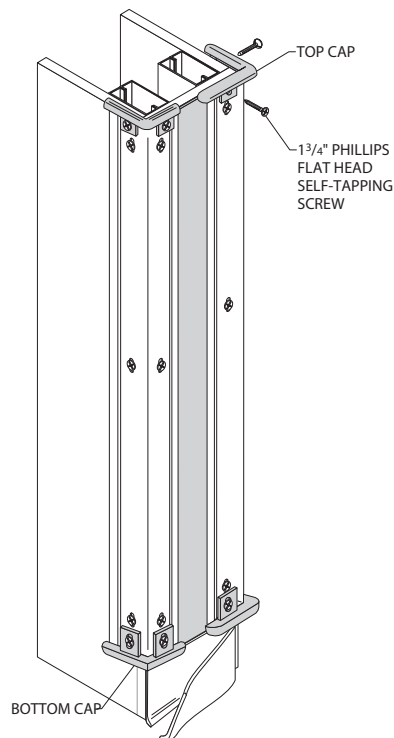

3. Overlap the retainer with the mounting tabs of the top and bottom caps and attach them to retainer. SEE FIG. 3

Note: For concrete installation, overlap the retainer with the mounting tabs of the top and bottom caps and attach them to retainer and into the Alligator anchors using two, #8 x 1 1/2" phillips flat head screws per cap.

4. Position cover on retainer and adjust the top cap for a tight fit. Starting at the top, push cover onto retainer pressing over the entire length until it snaps into place. Attach second corner guard in the same manner.

SEE FIG. 4

FIG. 4

