

## Trim (Aluminum Substrate)

### GENERAL

#### Description

WoodWorks Trim (aluminum substrate) is a unique system designed for use with Tegular, Vector®, Linear and Channeled ceilings from Armstrong. It is designed for full panel installations, but may also be used for field cut border panels.

The finned edge on the trim duplicates the 1/4" panel reveal at the edges of Vector installation. This option is for full panel installations only.

The flat edge on the trim is used for Tegular full panel installations and must be used for all cut Tegular and Vector, Linear and Channeled panels.

Two profile heights are available.

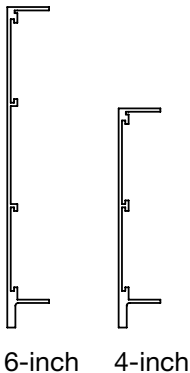

WoodWorks Trim comes in straight sections and can be field cut or mitered using a power miter saw equipped with a blade designed to cut aluminum.

Sawing, sanding and machining wood products can produce dust. Airborne wood dust can cause respiratory, eye and skin irritation. The International Agency for Research on Cancer (IARC) has classified wood dust as a nasal carcinogen in humans.

If power tools are used, they should be equipped with a dust collector. If high dust levels are encountered, use an appropriate NIOSH-designed dust mask. Avoid dust contact with eyes and skin.

Flush eyes or skin with water for at least 15 minutes.

These instructions are divided into four sections detailing material delivery, component assembly, installation and final detailing. Please carefully review all appropriate sections for your ceiling panel type (i.e. Vector, Linear or Channeled) before proceeding with installation.

### MATERIAL DELIVERY

Components and hardware are delivered to the job site in specially designed packaging. Exercise appropriate care to protect the finished surfaces of the trim.

### COMPONENT ASSEMBLY

Steel splice plates are used to align and secure all joints between sections of trim. Two splice plates are required at each joint. Splice plates are secured to the trim sections using factory-installed set screws. Where desired, it may be beneficial to caulk or tape the backside of the joints to prevent light transmission.

Position the splice plate in the bosses on the inside of the trim.

Pull the trim tightly together for the best fit.

Use a 1/8" hex key wrench to tighten the set screws that secure splice to trim.

**CAUTION:** Do not over-tighten these screws to the point where they distort the face of the trim.

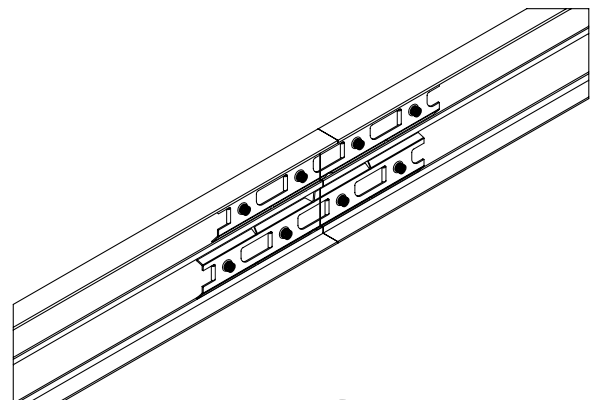

### 3.2 Corner Assembly

**3.2.1** Trim can be field mitered using a power miter saw equipped with a blade designed to cut aluminum.

**3.2.2** Bend the FXSPLICE splice plate at the center notches to form the desired angle.

**3.2.3** Position the mitered corner for correct alignment and tighten the two setscrews on the FXSPLICE plate.

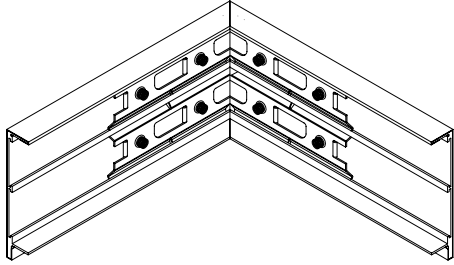

### 3.3 Grid Connector Clips

Clips are used to attach the trim to the supporting suspension system members. The appropriate clip will vary depending on the ceiling panel being used. Follow the recommendations for your product type.

Clips are attached to the grid members using screws or pop-rivets supplied by the installer. Framing screws (#6 x 7/16" or 1/2" lg.) are typical.

#### Typical procedure:

**3.3.1** Cut grid to length

**3.3.2** Attach clip to grid member

**3.3.3** Engage clip in lower trim bosses and tighten locking screw

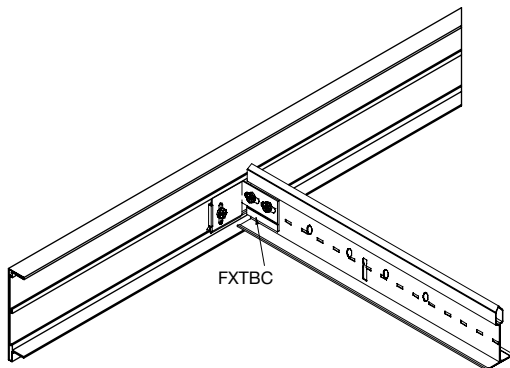

## 4. GENERAL INSTALLATION PROCEDURES

**4.1** Lay out and install the suspension system according to the reflected ceiling plan.

Installation procedures will be described separately for each type of panel.

### 4.2 Vector Full Panels

**4.2.1** Cut and install the grid to maintain precisely 23-1/16" between the outer edge of the 15/16" T-bar grid and the inner edge of the trim. The grid must rest approximately 1/4" to 3/8" on the trim flange.

**4.2.2** The correct length for the trim, when measured along the inside edge, will be 15/16" less than the nominal dimension of the full panel installation.

**EXAMPLE:** The nominal dimension of a four panel wide cloud would be 96". The trim should be cut to 95-1/16" measured along the inside edge.

**4.2.3** Attach the T-Bar Connector Clips (FXTBC) to each perimeter section of grid. Rest the bottom of the FXTBC on the grid flange. Insert one #7 x 7/16" framing screw (or equivalent) in the middle of the slot.

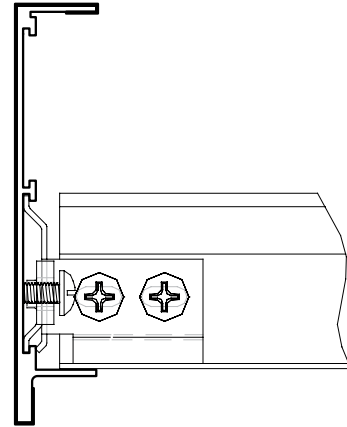

### 4.2.4 Install the Trim

Hang the sections of trim with fin side down for Vector, onto the grid system by engaging the top ear of the connector clips under the boss of the trim. Slide the back plate downward to engage the lower boss on the trim and secure by tightening the locking screw.

**4.2.4.1** Complete the installation of all trim sections. Install and secure the splices.

**4.2.4.2** Make adjustments as necessary to properly align and space the complete installation. Insert a second framing screw in each of the FXTBC's to secure the system.

**4.2.5** Install the Vector panels as per instructions. The bottom of the Vector panel will be flush with the trim fin and maintain the 1/4" reveal along the perimeter.

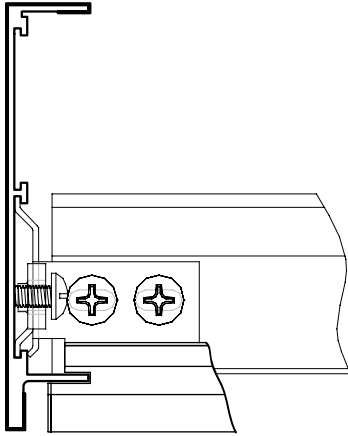

### 4.3 Tegular Full Panels

**4.3.1** Cut and install the grid to maintain precisely 23-7/16" between the outer edge of the 9/16" grid and the inner edge of the trim. The grid must rest approximately 1/4" on the trim flange.

**4.3.2** The correct length for the trim, when measured along the inside edge, will be 9/16" less than the nominal dimension of the full panel installation.

EXAMPLE: The nominal dimension of a four panel wide cloud would be 96". The trim should be cut to 95-7/16" measured along the inside edge.

**4.3.3** Attach the T-Bar Connector Clips (FXTBC) to each perimeter section of grid. Rest the bottom of the FXTBC on the grid flange. Insert one #7 x 7/16" framing screw (or equivalent) in the middle of the slot.

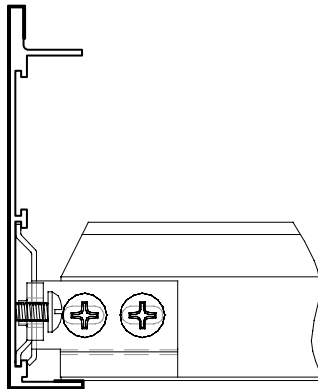

### 4.3.4 Install the Trim

Hang the sections of trim with the flat side down for Tegular, onto the grid system by engaging the top ear of the connection clips under the boss of the trim. Slide the back plate downward to engage the lower boss on the trim and secure by tightening the locking screw.

**4.3.4.1** Complete the installation of all trim sections. Install and secure the splices.

**4.3.4.2** Make adjustments as necessary to properly align and space the complete installation. Insert a second framing screw in each of the FXTBC's to secure the system.

**4.3.5** Install the Tegular panels as per instructions.

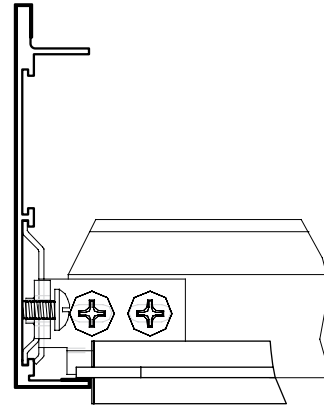

**NOTE:** The screws in the FXTBC may interfere with the insertion of the panel along the trim. Fit the panel edge into the grid at the sides and slide the panel back under the screws until the panel drops into the grid.

### 4.4 Cut Border Panels

**4.4.1** The cut edge of all panels must rest on the trim flange. All installations with cut borders will have the trim installed with the flat side down.

### 4.4.2 Vector Cut Border Panels

The face of Vector panels is 7/16" below the face of the grid. Since the cut panel edge must rest on the trim flange, the grid must be raised 7/16" above the trim flange. To do this, you must use the optional Vector T-bar Connector Clip (FXVTBC, 10 pcs/ctn) ordered separately for cut border installations. A clip is required for each end of grid attached to the trim. Cut the bottom of the clip off at the score line.

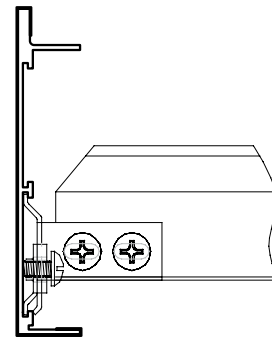

Lay out and cut the grid 1/4" larger than the required border size. Install the FXVTBC with the clip resting on the grid flange for the proper 7/16" clearance. Insert one #7 x 7/16" framing screw (or equivalent) in the middle of the slot.

Install the trim using same method as full panel installation. Follow the installation instructions for Vector panels.

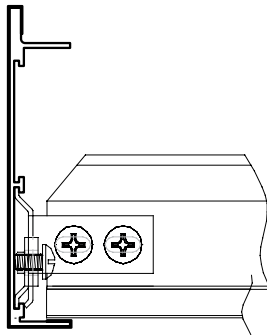

Vector cut border, rest cut panel edge on bulkhead flange

#### 4.4.3 Tegular Cut Border Panels

The face of Tegular panels is 1/4" below the face of the grid. Since the cut panel edge must rest on the trim flange, the grid must be raised 1/4" above the trim flange. To do this, you must modify the T-bar Connector Clip (FXTBC). Use snips to cut off the 1/4" tab at the bottom of the clip. A clip is required for each end of grid attached to the trim.

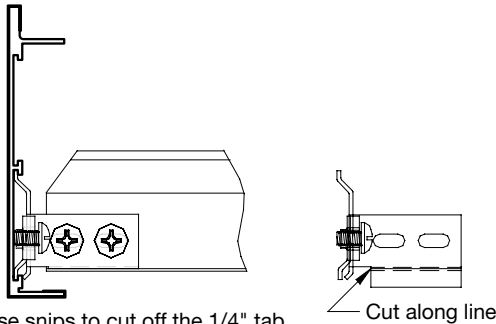

Use snips to cut off the 1/4" tab,

Cut along line

Lay out and cut the grid 1/4" larger than the required border size. Install the modified FXTBC with the clip resting on the grid flange for the proper 1/4" clearance. Insert one #7 x 7/16" framing screw (or equivalent) in the middle of the slot. Install the trim using same method as full panel installation. Follow the installation instructions for Tegular panels. Install hold down clip FXSPHDC as required.

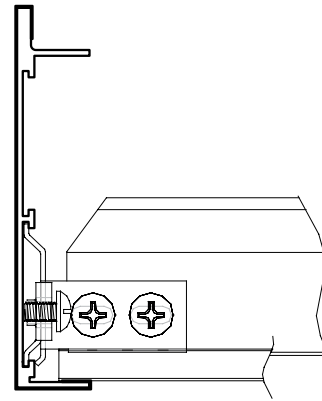

WoodWorks Trim Tegular cut border, rest cut panel edge on bulkhead flange

### 4.5 Linear and Channeled Installation

#### 4.5.1 Support Options

Floating installations of linear wood and channeled wood surrounded with WoodWorks Trim (aluminum substrate) may be supported using one of the following methods:

**4.5.1.1 Hanger wires direct to carriers/main beams** – Carriers/main beams are to be spaced not more than 24" from the edges of the cloud and then at 24" centers. Each row of carriers/main beams is to be supported by minimum #12 gage wires located not more than 12" from the ends of each row and then at 48" centers. Cross tees are to be installed in rows not more than 24" from the ends of the carriers/main beams and then 48" on center. Cross tees that extend from the last carrier to the perimeter trim are to be supported by wires placed closer to the trim than the midpoint of the tee.

#### 4.5.1.2 SH12 Support Hanger

When the SH12 support hanger is used to support the cloud the hangers will attach to the support hanger, not to the carriers or main beams. Support hangers are to be located at a line of cross tees not more than 24" from the ends of the carriers and then at 48" centers. Each row of support hanger is to be suspended from minimum #12 gage wire located not more than 24" from the edge of the cloud and then at 48" centers.

#### 4.5.2 Linear Wood Design Considerations

Floating installations of linear wood are attached to a suspension system that is made up of main carriers and cross tees. The wood slats are attached to specially designed clips that are fixed to the carriers. The placement of these clips blocks access to some of the rout holes that are used to connect the cross tees. When the 4-1/2" module planks and carriers are used every fourth rout hole along the length of the carrier is available to install the cross tees; additionally, these carriers are handed, meaning that once the first carrier in a row is installed subsequent carriers may not be turned end-for-end. Plan the installation carefully to insure that rout holes for cross tees are available within 24" of each end of the run of carriers and that the holes align from one row of carriers to the next.

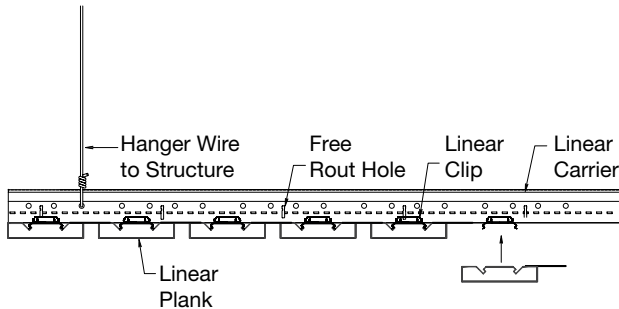

All cross tee routs are blocked when using the 6" module planks and carriers. In order to use these parts in a floating cloud installation a field rout tool (#7876) must be used to punch additional routs for the placement of the cross tees.

#### 4.5.3 Expansion/Contraction Control – Linear and Channeled

When installed within the range of temperature and humidity specified for this product the maximum amount of expansion or contraction anticipated will be 1/4" for every 8' of continuous wood. The horizontal flange of the trim will allow enough room for runs of wood up to sixteen feet in length. When installations are longer than this they must be broken into a series of clouds not to exceed 16' or additional expansion relief must be included within the larger cloud. This additional relief requires stopping and re-starting each row of planks and allowing an additional 1/4" space for every 8' of length in excess of the 16' controlled within the trim.

#### 4.5.4 Attaching the Trim – Linear and Channeled

The face of the grid must be held 7/8" above the lower flange of the perimeter trim. Use a modified twist clip (#5948) at each location where grid interfaces with the trim. Install the clips with screws or pop-rivets as shown in the drawing below.

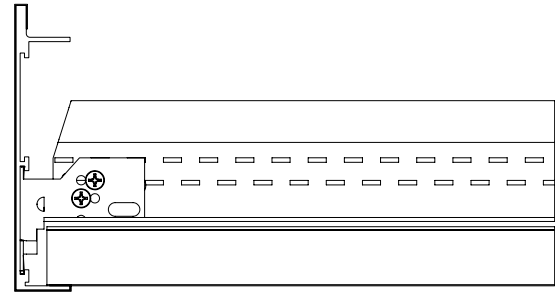

#### 4.5.5 Plank End Hold Down – Linear and Channeled

When the humidity or temperature varies there may be a tendency for the ends of the planks to curl up or down. The flange on the perimeter trim will control downward movement, but additional grid must be added to prevent upward movement from lifting the ends of planks off of the trim flange. Use the following procedure to control the ends of the planks:

1. Cut lengths of grid or steel stud to rest on the flanges of the grid parallel to the perimeter trim and as close as is practical. Secure these parts to the grid with framing screws inserted from below.
2. Install the planks and shim the gap between the top surface of the plank and the blocking. This gap is approximately 1/8". It can be filled by inserting material of the correct thickness between the plank and the blocking. Alternately, drive two framing screws into the bottom of the blocking before installing each plank. The heads of these screws can be used to take up the space between the top of the plank and the blocking.

#### 4.5.6 Hints for Full Width Plank Installations – Linear

For 4-1/2" planks – cut the carriers 2" beyond the centerline of the last clip.

For 6" planks – cut the carriers 2-3/4" beyond the centerline of the last clip.

The face of the trim will be 3/8" further away from the end of the carriers (example – for a cloud floating on all sides – measure the overall length of the carriers prepared as stated above and add 3/4" for the length of the perimeter trim that will run perpendicular to the length of the carriers.)

#### **4.6 Add additional hanger wires as required.**

**4.6.1** The manufacturer requires that trim and their supporting suspension systems be installed and supported in a manner that complies with all applicable codes and standards. Typically this will require the use of #12 ga. galvanized, soft annealed steel wire or equivalent. Specification and approval of alternate materials should be by design professionals familiar with the project. Mechanics should exercise care in the application of hangers to minimize the visual impact on the finished installation. Wire wraps should be tight and neat, and where appropriate, the wires may be painted to blend into the background as much as possible.

**4.6.2** Main beams must be supported 4' on center or by calculation based on actual ceiling weight.

**4.6.3** Cross tees located closest to the corners of the perimeter trim and then at 4' centers must be supported by wires closer to the trim than the midpoint of the tee.

**4.6.4** Installations in areas requiring seismic restraint may require wires attached to each grid member within 8" of the cut end. Lateral force bracing shall be consistent with locally approved standards or as detailed in the specifications.

### **5. FINAL DETAILING**

**5.1** Check and adjust the alignment of trim components and ceiling panels.

**5.2** Clean exposed surfaces as required. Trim and panels may be wiped down with a mild household cleaner to remove fingerprints, oil, etc.

**5.3** For light cove applications, a dark latex chalk or tape should be applied to the inside of all seams if light leaks are apparent.



Printed on recyclable paper  
with vegetable-based inks.  
Please Recycle. 

### **MORE INFORMATION**

For more information, or for an Armstrong representative, call 1 877 276 7876.

For complete technical information, detail drawings, CAD design assistance, installation information and many other technical services, call TechLine™ services at 1 877 276 7876 or FAX 1 800 572 TECH.

For the latest product selection and specification data, visit [armstrongceilings.com/trim](http://armstrongceilings.com/trim).

U.S. Patents Pending, including US Publication No. 2004/0182022.

All trademarks used herein are the property of AWI Licensing Company and/or its affiliates  
© 2010 AWI Licensing Company • Printed in the United States of America

LA-297580-710

