



Prices effective February 6, 2017

Published August 2017

Meridian® Lateral Files

| | |
|--|---------------|
| Introduction | page 2 |
| Meridian® Lateral Files | 3 |
| Stackable™ Lateral Files (Spec-A-File) | 5 |
| Freestanding Stackable Lateral Files (Standard Configuration) | 25 |
| Standard Pull | 25 |
| Arc Pull | 30 |
| Bar Pull | 36 |
| Bevel Pull | 42 |
| Ellipse Pull | 47 |
| Sloped Pull | 52 |
| Stackable Lateral File Cushion Tops | 58 |
| Mobile Stackable Lateral Files | 60 |
| Standard Pull | 60 |
| Bevel Pull | 64 |
| Low Credenza | 69 |
| File Tops | 74 |
| File Surrounds | 77 |
| Stackable Lateral File Accessories | 86 |
| Keyless Locks | 92 |
| Indices | 95 |
| By Name | 95 |
| By Number | 97 |
| Appendices | |
| 20-Day or Less/Assigned Lead-Time Order Information | |
| Keyed-Alike Information | |
| Vary Easy Program | |
| Stain-to-Match Program | |
| Customer's Own Material/Customer's Own Leather Order Information-Cushion Tops | |
| Proprietary Textiles Application Chart-Seating | |
| Proprietary Textile Colors-Seating | |
| Maharam® Application Chart-Seating | |
| Maharam Colors-Seating | |
| For the latest materials information, refer to the Materials pages on HermanMiller.com. | |

Introduction

A Note on the Organization of This Book

There are a few signals that will help you understand the organization of this book. Once you know them, you should be able to find your way around easily.

Like a newspaper, this book is formatted with columns of text and illustrations that run vertically.

Information wraps from one column to the next and continues for as many pages as it needs to.

Black bars are clues.

A black bar at the top of a page signals the start of information about a product.

This information is divided into two sections, each signaled by a black bar. Product Information includes a description, additional notes, and dimensional drawings. Specification Information, which always begins at the top of a column, includes a series of steps. Each step represents a decision you need to make in order to complete your product number. Steps must be followed sequentially. The number of pages needed to complete information on a product varies; some will be complete in one page; others may fill three or four pages. Just continue going through the steps until you run into the next product, signaled by the black bar at the top of the page.

Black tabs running along the outside edge of the page help you locate what section you are in or what section you want to go to. You can thumb forwards or backwards to find a section; tabs and text appear on both sides of the page.

The additional pages in the back of the book include the appendices and indices. They are signaled by a long black bar running along the outside edge of the page.

The index is presented two ways.

The first index is in alphabetical order by product name. It can be helpful if you are new to the products and numbering scheme or if you are looking for a type of product, such as work chair or round table.

The second index is by product number. It lists, in alphanumeric order, the base product number, typically a five-digit number.

General Information

This book is effective February 6, 2017, subject to change without notice. Products may be purchased from authorized Herman Miller dealers who will quote prices upon request. For more information about our products and services or to see a list of dealers, visit www.HermanMiller.com.

All prices are list prices. Additional services, such as planning services, design, storage, and installation, are not included and must be added to these prices when the additional services are requested.

Illustrations, specifications, and prices are based on the latest information at the time of publication. The right is reserved to make changes at any time without notice in prices, fabrics, finishes, materials, specifications, and models, and also to discontinue models and finishes.

Dimensions shown in the drawings are engineering drawing dimensions rounded up to the nearest $\frac{1}{8}$ ". Product is shipped set up or knocked down. Products that include "Shipped knocked down" in the description require some assembly. If this statement does not appear in the description, the product is shipped assembled.

Service problems are normally handled by a Herman Miller authorized dealer. Where this cannot be accomplished on a local level, service problems should be referred to the Customer Care Representative for your region, Herman Miller, Inc., Zeeland, Michigan 49464.

20-Day or Less/Assigned Lead-Time Shipments

All products and options in this price book not designated by an Assigned Program icon  will ship in **20 business days or less** after being acknowledged by Herman Miller.

Products and options designated by an  are on the assigned lead-time program and may ship in 20 days, less than 20 days, or more than 20 days from order acknowledgement.

Stackable™ Lateral Files (Spec-A-File)

Meridian® Stackable™ Lateral Files

Drawer Capacity & 20" Depth Filing

| Drawer Capacity | Module Type | Case Depth | 30" Letter | 30" Legal | 36" Letter | 36" Legal | 42" Letter | 42" Legal |
|-----------------|---|------------|--------------------|------------|--------------------|--------------------|--------------------|--------------------|
| | Side-to-Side Filing in: C, D, N, E, G, H, L & P modules | 20" or 18" | 26 1/2" | 26 1/2" | 32 1/2" | 32 1/2" | 38 1/2" | 38 1/2" |
| | Front-to-Back Filing in: N, P, E & D modules | 20" 18" | 35 1/2" 31 1/2" | N/A N/A | 41 1/2" 37 1/2" | 35 1/2" 31 1/2" | 53 1/4" 47 1/4" | 35 1/2" 31 1/2" |

Filing Comparison

42" Wide Drawers

Side-to-Side Letter or Legal
38 1/2 Filing Inches

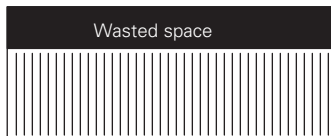

Front-to-Back Letter
53 1/4 Filing Inches



Note: 38% more filing capacity than side-to-side filing.

36" Wide Drawers

Side-to-Side Letter or Legal
32 1/2 Filing Inches

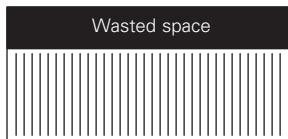

Front-to-Back Letter
41 1/2 Filing Inches



Note: 28% more filing capacity than side-to-side letter type.

Front-to-Back Legal
35 1/2 Filing Inches

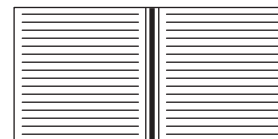

Note: 9% more filing capacity than side-to-side legal type.

30" Wide Drawers

Side-to-Side Letter or Legal
26 1/2 Filing Inches

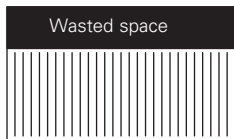

Front-to-Back Letter
35 1/2 Filing Inches

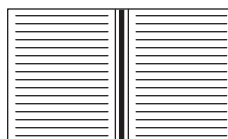

Note: 34% more filing capacity than side-to-side letter type.

Meridian® Stackable™ Lateral Files

General Information

Standard Pull (26)

Bar Pull (2KP)

Bevel Pull (24)

Spec-A-File

General Information

General Information

The Spec-A-File ordering procedure was designed to aid specifiers in meeting their exact filing needs. Since each component of the file (top, module, interior, base) is chosen individually, each file is a unique storage solution. The variety of top, module, and base heights available make the concern of meeting critical vertical heights a thing of the past.

Spec-A-File is comprised of the following four components. Each component must be clearly specified and priced separately.

Note: Metallic paints have an upcharge of \$65 when specified for the case, and \$10 when specified for the leg base.



Tops

Four heights are available ($\frac{1}{32}$ " , 1" , $1\frac{1}{4}$ " , $6\frac{1}{2}$ ") in finishes of baked enamel. Laminate and veneer tops are available in $1\frac{1}{4}$ " only. Veneer tops with oversail edge are $1\frac{1}{8}$ " .

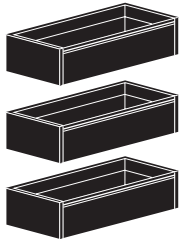

Modules

Various modules are available in heights of $11\frac{3}{4}$ " , $13\frac{1}{8}$ " , $15\frac{1}{8}$ " , $17\frac{5}{8}$ " , and $26\frac{1}{4}$ " .

Interiors

Several interior options are provided to meet your filing needs.



Bases

Five heights are available (1" , $1\frac{1}{2}$ " , $2\frac{1}{4}$ " , $3\frac{1}{4}$ " , $4\frac{1}{4}$ ") in finishes of baked enamel.

Locks

Flush locks.



Final Assembly

Meridian will assemble all components as a complete lateral file up to 78" . Files taller than 78" will be shipped as two units for final field assembly. Instructions are included.

Meridian® Stackable™ Lateral Files

Advanced Options

Spec-A-File



Add-On Modules

In order to accommodate additional filing needs, add-on modules are available for field installation to an existing lateral file. Modules do not have a base and can be ordered with or without a top. If a lock cylinder is needed, see lock appendix for ordering information. If the lock cylinder resides in the existing file, the add-on modules will need to be specified with lockbars.

Example: 26-3618-ADDON

Lock Option: LB-Lockbars, to attach to an existing unit



Reversed Modules

Reversed file drawers allow one stack of lateral file modules to service two users—conserving floor space. For safety reasons, only one direction reversal is allowed per file. The number of modules facing each direction is not limited.

Drawers are reversed in the field by utilizing a stile lock hardware kit for additional lock and a reversing conversion kit for additional inter-lock pieces. Kit number: U1B31V4

Factory-reversed units need to be ordered through Herman Miller Options.

Advanced Options

The flexibility and modularity of the stackable lateral file modules allow a specifier to create an infinite number of storage solutions.

To further enhance the uniqueness of the file, use one of the following advanced options available in Advanced Spec-A-File:

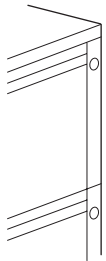

Multiple Locks – Standard Pull

Since the lock is housed in the module frame of standard pull lateral files, locks can be strategically placed to accommodate multiple users in one filing unit. In the case of keyed alike, identified modules will have factory-installed lockbars and lock hole knocked out to allow for field installation of lock cylinder. If additional security is required between drawers, specify security pans between modules.

Existing files can be retrofitted with multiple locks by requesting a stile lock hardware kit from your Customer Care representative.

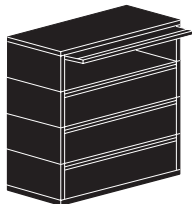

Combination Lateral File

It is considered to be a combination lateral file when combining standard pull with bevel or contour pull lateral file drawers. To specify a combination unit, choose a bevel or contour pull lateral file in Advanced Spec-A-File. The standard pull modules will be listed on the module choices, signified by the following note (2600 Series).

Multiple Paints

Multiple paints are available on a single unit by specifying one of the following options:

F: Different case and front finishes
M: Different top, module, and base finishes
N: Unit all one color







Meridian® Stackable™ Lateral File Tops

Standard Pull (26)

Bar Pull (2KP)

Bevel Pull (24)

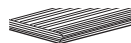
Spec-A-File

| Tops | Description | Spec Code | H | D | W | LIST PRICE |
|---|--|--|----------------|-------------------|------------|----------------|
| No Top | | NT | | | | N/C |
|  Square Edge Metal Top | Metal top with square edge. Baked enamel finish. | T1 | 1" | 20" or 18" | 30" | \$ 63. |
| | | | | | 36" | \$ 79. |
| | | | | | 42" | \$ 94. |
| | | T2 | 1 1/4" | 20" or 18" | 30" | \$ 63. |
| | | | | | 36" | \$ 79. |
| | | | | | 42" | \$ 94. |
|  Radius Edge Metal Top | Metal top with radius edge front and back. Baked enamel finish. | T3 | 1 1/4" | 20" or 18" | 30" | \$ 126. |
| | | | | | 36" | \$ 141. |
| | | | | | 42" | \$ 157. |
|  Laminate Top with Vinyl Edge* | Laminate top with vinyl edge. | TL | 1 1/4" | 20" or 18" | 30" | \$ 135. |
| | | | | | 36" | \$ 150. |
| | | | | | 42" | \$ 166. |
|  Wood Veneer Top | Wood veneer top with 3mm edge banding. | TF A | 1 1/4" | 20" or 18" | 30" | \$ 218. |
| | | | | | 36" | \$ 234. |
| | | | | | 42" | \$ 251. |
|  Recut Veneer Top | Recut veneer top with 3mm edge banding. | TR A | 1 1/4" | 20" or 18" | 30" | \$ 212. |
| | | | | | 36" | \$ 228. |
| | | | | | 42" | \$ 245. |
|  Wood Veneer Top with Oversail Front Edge* | Wood veneer top and wood composite edge with oversail front. | TV1 A | 1 1/8" | 20" or 18" | 30" | \$ 385. |
| | | | | | 36" | \$ 400. |
| | | | | | 42" | \$ 417. |
|  Security Top | Flat steel cover with baked enamel finish. Designed to protect contents and minimize overall height; not to be used for support or as an exposed top. Available on N, E and H modules and Overhead Storage Units only. | T6 | 1 1/32" | 20" or 18" | 30" | \$ 63. |
| | | | | | 36" | \$ 79. |
| | | | | | 42" | \$ 94. |
| Note: Not field installable on Overhead Storage Units. | | | | | | |
|  Planter Top* | Steel shell with baked enamel finish. Includes black plastic tub liner. Cannot house a lock. | T7 | 6 1/2" | 20" or 18" | 30" | \$ 264. |
| | | | | | 36" | \$ 278. |
| | | | | | 42" | \$ 296. |
| <p>* Note: When ordering a radius edge laminate top, laminate top with vinyl edge banding, planter top with a bevel pull product, or a veneer top with oversail edge, an additional top is required if the file is to include a lock. Call Customer Service for details.</p> | | | | | | |



Meridian® Stackable™ Lateral File Dome Tops

Standard Pull (26)

Bar Pull (2KP)

Bevel Pull (24)

Spec-A-File

| Tops | Description | Spec Code | H | D | W | LIST PRICE |
|---|--|-----------|--------|------------|-----|------------|
| Full Dome Top  | 6 1/2" high metal top with full dome side-to-side. Baked enamel finish. | D1 | 6 1/2" | 18" or 20" | 30" | \$ 337. |
| | | | | | 36" | \$ 353. |
| | | | | | 42" | \$ 369. |
| Half Dome Top  | 6 1/2" high metal top with half dome sloping left. Baked enamel finish. | H1 | 6 1/2" | 18" or 20" | 30" | \$ 337. |
| | | | | | 36" | \$ 353. |
| | | | | | 42" | \$ 369. |
|  | 6 1/2" high metal top with half dome sloping right. Baked enamel finish. | H2 | 6 1/2" | 18" or 20" | 30" | \$ 337. |
| | | | | | 36" | \$ 353. |
| | | | | | 42" | \$ 369. |

Note: When specifying a half dome or full dome top with bevel or bar pull lateral files, a lock option is not available.

Meridian® Stackable™ Lateral File Cushion Tops/Cushion Fabrics

Standard Pull (26)

Bar Pull (2KP)

Bevel Pull (24)

Spec-A-File

| Tops | Description | Spec Code | H | D | W | LIST PRICE |
|--|--|-----------|----|------------|-----|------------|
|  | Cushion top available 1" or 2" high, provides temporary guest seating. Attaches with velcro strips to 1" metal top included. | TC1 | 1" | 18" or 20" | 30" | \$ 390. |
| | | TC2 | 2" | | 36" | \$ 390. |
| | | | | | 42" | \$ 391. |

| Tops | Description | Spec Code | Fabric Category | UPCHARGE |
|--|---|---|------------------|----------|
|  | Cushion available in Herman Miller seating fabric. Fabric requirements: Customer's Own Material (COM) requires yardage listed below. | See textile appendices for fabric families and color codes. | Price Category 1 | N/C |
| | | | Price Category 2 | \$ 68. |
| | | | Price Category 3 | \$ 82. |
| | | | Price Category 4 | \$ 101. |
| | | | Price Category 7 | \$ 137. |
| | | | Price Category 9 | \$ 950. |
| | | | Price Category B | \$ 47. |
| | | | Price Category E | \$ 99. |
| | | | Price Category F | \$ 141. |
| | | | Price Category G | \$ 166. |
| | | | Price Category H | \$ 204. |
| Price Category I | \$ 264. | | | |

| Width of Cushion | Yards of Fabric |
|------------------|-----------------|
| 30" | 1.05 |
| 36" | 1.22 |
| 42" | 1.40 |

When ordering more than one cushion, please round up the total yardage requirement to the next full yard of fabric.

Meridian® Stackable™ Lateral File Overhead Storage Units

Standard Pull (26)

Bar Pull (2KP)

Bevel Pull (24)

Spec-A-File

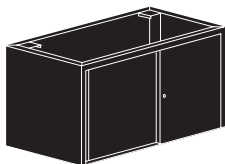
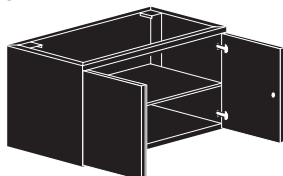
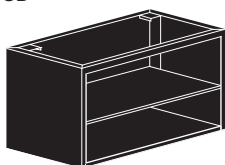

| Description | | Spec Code | H | D | W | Standard Pull (26) | Bar Pull (2KP) | Bevel Pull (24) |
|--|--|-----------|---------|-----|---------|--------------------|----------------|-----------------|
| 26 1/4" High | | | | | | | | |
| OS  | Overhead Storage*. Cabinet with locking sliding doors. Includes one adjustable shelf. (KA) lock options not available. Interior depth: 18" (20") and 16" (18"). Interior height: 24 1/4". | OS | 26 1/4" | 20" | 30" | \$ 534. | N/A | N/A |
| | | | | | 36" | \$ 609. | N/A | N/A |
| | | | | | 42" | \$ 685. | N/A | N/A |
| | | | | | 18" 30" | \$ 534. | N/A | N/A |
| | | | | | 36" | \$ 609. | N/A | N/A |
| | | | | | 42" | \$ 685. | N/A | N/A |
| OH  | Overhead Storage*. Cabinet with locking hinged doors. Includes one adjustable shelf. Interior depth: 18" (20") and 16" (18"). Interior height: 24 1/4". | OH | 26 1/4" | 20" | 30" | \$ 581. | \$ 605. | \$ 581. |
| | | | | | 36" | \$ 652. | \$ 679. | \$ 652. |
| | | | | | 42" | \$ 731. | \$ 761. | \$ 731. |
| | | | | | 18" 30" | \$ 581. | \$ 605. | \$ 581. |
| | | | | | 36" | \$ 652. | \$ 679. | \$ 652. |
| | | | | | 42" | \$ 731. | \$ 761. | \$ 731. |
| OB  | Overhead Storage*. Cabinet without doors. Includes one adjustable shelf. Interior depth: 18" (20") and 16" (18"). Interior height: 24 1/4". | OB | 26 1/4" | 20" | 30" | \$ 491. | \$ 491. | N/A |
| | | | | | 36" | \$ 569. | \$ 569. | N/A |
| | | | | | 42" | \$ 641. | \$ 641. | N/A |
| | | | | | 18" 30" | \$ 491. | \$ 491. | N/A |
| | | | | | 36" | \$ 569. | \$ 569. | N/A |
| | | | | | 42" | \$ 641. | \$ 641. | N/A |

Note:
*When ordering an overhead storage with a bevel pull lateral file, an additional top is required if the file drawers are to lock. Call Customer Service for details.

Application Notes:
*Other modules can be placed on top of an overhead storage unit only if they have a fixed shelf.



Pull out shelves may not be used above an overhead storage unit.

Note:
Doors and drawers will be proud of this module.

Meridian® Stackable™ Lateral File Overhead Storage Units – Multi-User Standard Pull (26)

Spec-A-File

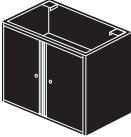

| Tops | Description | Spec Code | H | D | W | Standard Pull (26) | LIST PRICE |
|--|--|-----------|------|-----|-----|--------------------|------------|
|  | 23½" partitioned overhead storage unit with two individually locking hinged doors and one adjustable shelf per opening. Interior depth: 18" (20") and 16" (18"). Interior height: 21½". | OI | 23½" | 20" | 30" | | \$ 897. |
| | | | | | 36" | | \$ 968. |
| | | | | | 42" | | \$ 1038. |
| | | | | | 18" | 30" | \$ 897. |
| | | | | | 36" | | \$ 968. |
| | | | | | 42" | | \$ 1038. |
|  | 26¼" partitioned overhead storage unit with two individually locking hinged doors and one adjustable shelf per opening. Interior depth: 18" (20") and 16" (18"). Interior height: 24¼". | OM | 26¼" | 20" | 30" | | \$ 926. |
| | | | | | 36" | | \$ 995. |
| | | | | | 42" | | \$ 1066. |
| | | | | | 18" | 30" | \$ 926. |
| | | | | | 36" | | \$ 995. |
| | | | | | 42" | | \$ 1066. |

The OI and OM overhead storage units can be used in conjunction with individually locking standard pull drawer modules to create multi-user storage and filing units. Security pans between drawers are available. Modules can also be reversed. The following examples can be used as guidelines, or contact your Customer Care representative for more details on reversed module stack combinations.

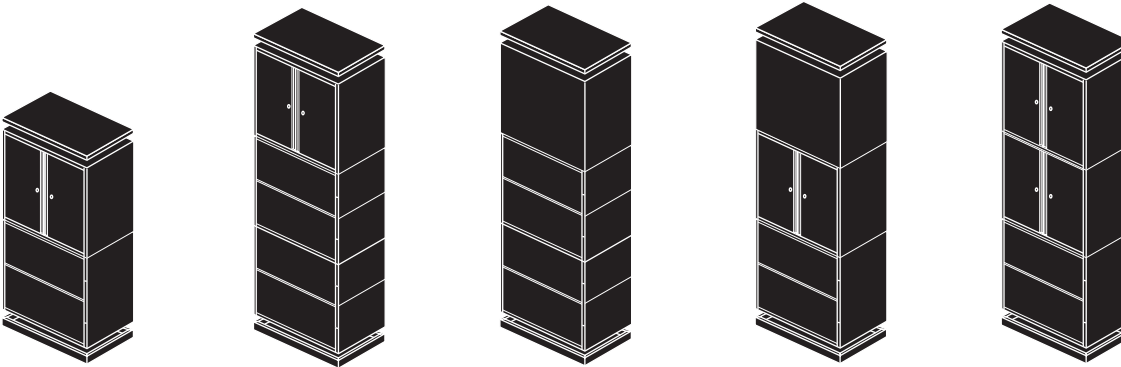

| Additional Storage Shelf | Description | Spec Code | Cabinet | D | W | LIST PRICE |
|--|---|-----------|---------|---|---|------------|
|  | Adjustable steel shelf with baked enamel finish. 15" fits one opening of 30" wide partitioned cabinet. 18" fits one opening of 36" wide partitioned cabinet. 21" fits one opening of 42" wide partitioned cabinet. | SSF-15 | | | | \$ 55. |
| | | SSF-18 | | | | \$ 61. |
| | | SSF-21 | | | | \$ 66. |
| | | | | | | |

Meridian® Stackable™ Lateral File Modules

Standard Pull (26)

Bar Pull (2KP)

Bevel Pull (24)

Spec-A-File

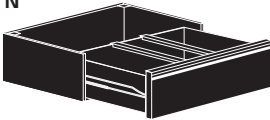
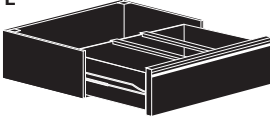
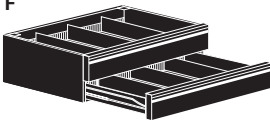
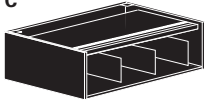
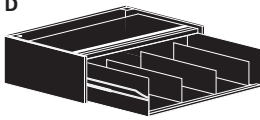

| Modules | Description | Spec Code | H | D | W | Standard Pull (26) | Bar Pull (2KP) | Bevel Pull (24) |
|---|---|-----------|----------------------------------|------------|-----|--------------------|----------------|-----------------|
| LIST PRICE | | | | | | | | |
| 11³/₄" High | | | | | | | | |
| N  | File drawer / fixed front. Standard 9P interior: hanging folder rails for front-to-back filing. Optional interiors: 9M, 9R, 9W-LT, 9W-LG, 9C-LT, 9C-LG. Interior depth: 17 ³ / ₄ " (20") or 15 ³ / ₄ " (18"). Interior height: 10 ⁵ / ₈ ". Hanging clearance: 9 ⁷ / ₁₆ " for 9P, 9R, 9C-LG, 9C-LT. | N | 11 ³ / ₄ " | 20" or 18" | 30" | \$ 317. | \$ 330. | \$ 317. |
| | | | | | 36" | \$ 346. | \$ 360. | \$ 346. |
| | | | | | 42" | \$ 389. | \$ 408. | \$ 389. |
| | | | | | | | | |
| 13¹/₈" High | | | | | | | | |
| E  | File drawer / fixed front. Standard 9P interior: hanging folder rails for front-to-back filing. Optional interiors: 9M, 9R, 9W-LT, 9W-LG, 9C-LT, 9C-LG. Interior depth: 17 ³ / ₄ " (20") or 15 ³ / ₄ " (18"). Interior height: 12". Hanging clearance: 9 ⁷ / ₁₆ " for 9P, 9R, 9C-LG, 9C-LT. | E | 13 ¹ / ₈ " | 20" or 18" | 30" | \$ 317. | \$ 330. | \$ 317. |
| | | | | | 36" | \$ 346. | \$ 360. | \$ 346. |
| | | | | | 42" | \$ 389. | \$ 408. | \$ 389. |
| | | | | | | | | |
| F  | Two half height drawers with fixed fronts. Standard 9T interior: 3 adjustable partitions per half drawer for index card filing. Interior depth: 17 ³ / ₄ " (20") or 15 ³ / ₄ " (18"). Interior height: 5 ³ / ₈ ". | F | 13 ¹ / ₈ " | 20" or 18" | 30" | \$ 611. | \$ 636. | \$ 611. |
| | | | | | 36" | \$ 640. | \$ 666. | \$ 640. |
| | | | | | 42" | \$ 683. | \$ 711. | \$ 683. |
| | | | | | | | | |
| C  | Fixed shelf / flip door. Standard 9M interior: 3 movable dividers for side-to-side paper folder filing. Optional interiors: 9V. Interior depth: 17 ³ / ₄ " (20") or 15 ³ / ₄ " (18"). Interior height: 10 ¹ / ₄ ". | C | 13 ¹ / ₈ " | 20" or 18" | 30" | \$ 321. | N/A | \$ 321. |
| | | | | | 36" | \$ 353. | N/A | \$ 353. |
| | | | | | 42" | \$ 397. | N/A | \$ 397. |
| | | | | | | | | |
| D  | Pull-out shelf / flip door. Standard 9M interior: 3 movable dividers for side-to-side paper folder filing. Optional interiors: 9Q, 9R, 9V, 9W-LT, 9W-LG, 9C-LT, 9C-LG. Interior depth: 17 ³ / ₄ " (20") or 15 ³ / ₄ " (18"). Interior height: 10 ¹ / ₄ ". Hanging clearance: 9 ⁷ / ₁₆ " for 9P, 9R, 9C-LG, 9C-LT. | D | 13 ¹ / ₈ " | 20" or 18" | 30" | \$ 361. | N/A | \$ 361. |
| | | | | | 36" | \$ 389. | N/A | \$ 389. |
| | | | | | 42" | \$ 431. | N/A | \$ 431. |
| | | | | | | | | |

Meridian® Stackable™ Lateral File Modules – *Continued*



Standard Pull (26)

Bar Pull (2KP)

Bevel Pull (24)

Spec-A-File



| Modules | Description | Spec Code | H | D | W | Standard Pull (26) | Bar Pull (2KP) | Bevel Pull (24) |
|--|---|-----------|-------------------------------------|-------------------|------------|--------------------|----------------|-----------------|
| LIST PRICE | | | | | | | | |
| 13¹/₈" High | | | | | | | | |
| J  | Open module with full back accommodates binders up to 11 ³ / ₄ " tall. Interior depth 17 ¹ / ₂ " or 19 ¹ / ₂ ". Interior height: 11 ⁷ / ₈ ". Accommodates 9Y interiors (sold separately). Note: Cannot be used as the bottom module if a counterbalance is specified. Note: Security top cannot be attached to a "J" module. Note: Door and drawers will be proud of this module when using bar pull. | J | 13¹/₈" | 20" or 18" | 30" | \$ 400. | \$ 400. | N/A |
| | | | | | 36" | \$ 423. | \$ 423. | N/A |
| | | | | | 42" | \$ 450. | \$ 450. | N/A |
| | | | | | | | | |
| K  | Pass through unit. Interior depth: 19 ³ / ₄ " (20") or 17 ³ / ₄ " (18"). Interior height: 11 ⁷ / ₈ ". Note: Not field installable. Note: Door and drawers will be proud of this module when using bar pull. | K | 13¹/₈" | 20" or 18" | 30" | \$ 327. | \$ 327. | N/A |
| | | | | | 36" | \$ 353. | \$ 353. | N/A |
| | | | | | 42" | \$ 399. | \$ 399. | N/A |
| | | | | | | | | |
| P  | Combination posting shelf and 11 ³ / ₄ " fixed front file pullout drawer. Standard 9P interior: hanging folder rails for front-to-back filing. Optional interiors: 9M, 9R, 9W-LT, 9W-LG, 9C-LT, 9C-LG. Interior depth: 17 ³ / ₄ " (20") or 15 ³ / ₄ " (18"). Interior height: 10 ⁵ / ₈ ". Hanging clearance: 9 ⁷ / ₁₆ " for 9P, 9R, 9C-LG, 9C-LT. | P | 13¹/₈" | 20" or 18" | 30" | \$ 444. | N/A | N/A |
| | | | | | 36" | \$ 476. | N/A | N/A |
| | | | | | 42" | \$ 517. | N/A | N/A |
| | | | | | | | | |

Meridian® Stackable™ Lateral File Modules – *Continued*

Standard Pull (26)

Bar Pull (2KP)

Bevel Pull (24)

Spec-A-File



| Modules | Description | Spec Code | H | D | W | Standard Pull (26) | Bar Pull (2KP) | Bevel Pull (24) |
|---------------------|--|-----------|---------|------------|-----|--------------------|----------------|-----------------|
| | | | | | | LIST PRICE | | |
| 15 1/8" High | | | | | | | | |
| | Fixed shelf / flip door. Standard 9M interior: 3 movable dividers for large folders and binder storage. Optional interiors: 9V. Interior depth: 17 3/4" (20") or 15 3/4" (18"). Interior height: 12 1/4". Note: Drawer front does not completely recede on 18" deep modules. | G | 15 1/8" | 20" or 18" | 30" | \$ 456. | N/A | N/A |
| | | | | | 36" | \$ 490. | N/A | N/A |
| | | | | | 42" | \$ 528. | N/A | N/A |
| | | | | | | | | |
| | Pullout shelf / flip door. Standard 9M interior: 3 movable dividers for large folders and binder storage. Optional interiors: 9V, 9W-LT, 9W-LG, 9X, 9Q. Interior depth: 17 3/4" (20") or 15 3/4" (18"). Interior height: 12 1/4". Hanging clearance: 9 9/16" for 9V, 11 9/16" for 9X. Note: Drawer front does not completely recede on 18" deep modules. | L | 15 1/8" | 20" or 18" | 30" | \$ 502. | N/A | N/A |
| | | | | | 36" | \$ 528. | N/A | N/A |
| | | | | | 42" | \$ 577. | N/A | N/A |
| | | | | | | | | |
| | File drawer / fixed front. Standard 9X interior: 2 rails for computer printout hanging binders and folders. Optional interiors: 9M, 9W-LT, 9W-LG, 9Q. To accommodate letter-width computer printout hanging binders, contact Meridian. Interior depth: 17 3/4" (20") or 15 3/4" (18"). Interior height: 14". Hanging clearance: 11 9/16" for 9X. | H | 15 1/8" | 20" or 18" | 30" | \$ 417. | \$ 434. | \$ 417. |
| | | | | | 36" | \$ 440. | \$ 459. | \$ 440. |
| | | | | | 42" | \$ 485. | \$ 504. | \$ 485. |
| | | | | | | | | |
| | Fixed shelf / locking sliding doors. Ideal for binder storage. Interior depth: 18" (20") or 16" (18"). Interior height: 13 1/8". (KA) lock options not available. | S | 15 1/8" | 20" or 18" | 30" | \$ 404. | N/A | N/A |
| | | | | | 36" | \$ 433. | N/A | N/A |
| | | | | | 42" | \$ 482. | N/A | N/A |
| | Two drawers with 1 half high and 1 file drawer. Interiors available: 9P, 9M, 9R, 9W-LT, 9W-LG, 9C-LT, 9C-LG, for file drawer only. Interior file drawer depth: 17 3/4" (20") or 15 3/4" (18"). Interior height: 10 5/8". Hanging clearance: 9 7/16" for 9P, 9R, 9C-LG, and 9C-LT 15 3/4" (18"). Interior height: 10 5/8". | X | 17 5/8" | 20" or 18" | 30" | N/A | \$ 845. | N/A |
| | | | | | 36" | N/A | \$ 925. | N/A |
| | | | | | 42" | N/A | \$ 1022. | N/A |
| | | | | | | | | |

Meridian® Stackable™ Lateral File Modules – *Continued*

Standard Pull (26)

Bevel Pull (24)

Spec-A-File

CD Storage*

| Drawer Size | Number of CDs per Row | Number of Complete Rows per Half Drawer |
|-------------|-----------------------|---|
| 30" x 18" | 40 | 4 |
| 30" x 20" | 44 | 4 |
| 36" x 18" | 40 | 5 |
| 36" x 20" | 44 | 5 |
| 42" x 18" | 40 | 6 |
| 42" x 20" | 44 | 6 |



*Calculation based on average CD size of $5\frac{5}{8}$ " x $4\frac{7}{8}$ " x $\frac{3}{8}$ ".

VHS Storage**

| Drawer Size | Number of VHS Tapes per Row | Number of Complete Rows per Half Drawer |
|-------------|-----------------------------|---|
| 30" x 18" | 12 | 3 |
| 30" x 20" | 14 | 3 |
| 36" x 18" | 12 | 4 |
| 36" x 20" | 14 | 4 |
| 42" x 18" | 12 | 4 |
| 42" x 20" | 14 | 4 |



**Calculation based on average VHS case size of 8" x $4\frac{3}{4}$ " x $1\frac{1}{4}$ ".

Meridian® Stackable™ Lateral Files

Interiors/Bases/Options











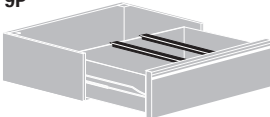

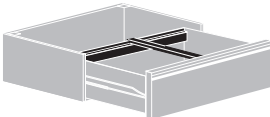

Standard Pull (26)

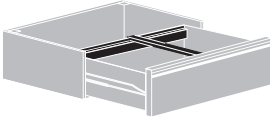
Bar Pull (2KP)

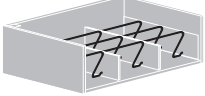
Bevel Pull (24)

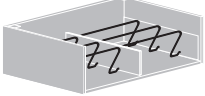
Spec-A-File

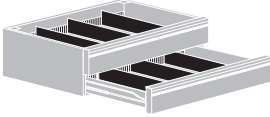
Note: Interiors 9P, 9Q, 9C-LG, 9C-LT, 9M and 9R for file drawer only in X module.

| Interiors | Description | Filing Devices | Spec Code | |
|---|--|--|--------------|----------------------|
| Front-To-Back Filing | | | | U P C H A R G E |
| 9P  | Front-to-back filing rails for hanging file folders. Standard in modules: E, N, P, X. |  Hanging File Folder | 9P | N/C |
| 9Q  | Front-to-back filing rails for hanging file folders. For use in flip door units. Optional in D, L and H modules. |  Hanging File Folder | 9Q | N/C |
| 9C-LG  | Combination front-to-back and side-to-side rails for filing one row side-to-side legal and one row front-to-back letter of hanging file folders. Optional in modules E, N, D, P, X. |  Hanging File Folder | 9C-LG | N/C |
| 9C-LT  | Combination front-to-back and side-to-side rails for filing one row side-to-side letter and one row front-to-back legal of hanging file folders. Optional in modules E, N, D, P, X. |  Hanging File Folder | 9C-LT | N/C |
| 9W-LT  | Wobble dividers for filing letter size paper folders front-to-back. Optional in modules N, E, D, P, L, H. |  File Folder | 9W-LT | 30" wide \$ 49. |
| | |  Expandable Pocket Folder | | 36" wide \$ 49. |
| | | | | 42" wide \$ 55. |
| 9W-LG  | Wobble dividers for filing legal size paper folders front-to-back. Optional in modules N, E, D, P, L, H. |  File Folder | 9W-LG | 30" wide \$ 49. |
| | | | | 36" wide \$ 55. |
| | | | | 42" wide \$ 55. |
| 9T  | Set of six movable partitions, 3 per half-height drawer. Standard in modules F only. | | 9T | N/C |
| 9Y  | Three movable magnetic dividers for large binder storage. Side-to-Side Filing only. 12" H X 5" W X 16" D | | 9Y | N/C |

Meridian® Stackable™ Lateral Files

Interiors/Bases/Options – Continued













Standard Pull (26)

Bar Pull (2KP)

Bevel Pull (24)

Spec-A-File

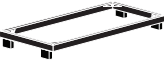
Note: Interiors 9P, 9Q, 9C-LG, 9C-LT, 9M and 9R for file drawer only in X module.

| Interiors | Description | Filing Devices | Spec Code | | | | |
|--|---|--|-----------|------------|-----|--|--|
| Side-To-Side Filing | | | | | | U P C H A R G E | |
| 9M  | Three movable dividers for filing paper folders. Standard in modules: C, D, G, L. Optional in modules: E, N, H, P, X. |  File Folder  Binder  Expandable Pocket Folder | 9M | | | N/C | |
| 9R  | Side-to-side rails for hanging file folders (letter, legal, A-4, foolscap). Optional in modules: E, N, D, H, P, X. 1 required for E, N, and P modules. 2 required for D and H modules. |  Hanging File Folder | 9R | | | N/C | |
| 9V  | Movable dividers (9M) with side-to-side rail (9R) for tab style side-to-side filing. Optional in modules: C, D, G, L. |  File Folder | 9V | | | N/C | |
| 9X  | Side-to-side filing rails for computer printout hanging binders and folders, 2 rails included. Standard in H module. Optional in L module. |  Standard Hanging Computer Paper Folder | 9X | | | N/C | |
| Bases / Options | Description | Spec Code | H | D | W | LIST PRICE | |
| Bases  | Frame-type steel base with baked enamel finish. Includes four adjustable leveling glides. | B1 | 1" | 20" or 18" | 30" | \$ 79. | |
| | | B2 | 1 1/2" | | 36" | \$ 94. | |
| | | B3 | 2 1/4" | | 42" | \$ 109. | |
| | | B4 | 3 1/4" | | | | |
| | | B5 | 4 1/4" | 20" or 18" | 30" | \$ 115. | |
| Leg Bases with Legs  | Frame-type steel base with baked enamel finish. Includes four Canvas-style legs. Note: Legs must be field installed. | | 1 1/2" | 20" or 18" | 30" | \$ 237. | |
| | | | | | 36" | \$ 254. | |
| | | | | | 42" | \$ 268. | |
| Recessed Bases  | Frame-type steel base with baked enamel finish. Recessed 1/16". Includes four adjustable leveling glides. | BA | 1" | 20" or 18" | 30" | \$ 115. | |
| | | BB | 1 1/2" | | 36" | \$ 132. | |
| | | BC | 2 1/4" | | 42" | \$ 146. | |
| | | BD | 3 1/4" | | | | |
| Lock | Flush lock. Locks are located in the module frame in the standard pull lateral file. Locks are located in the top in the bevel pull lateral files. | KD, KC, or KA | | | | \$ 38. | |
| Counterbalance Weight | Recommended for 2 and 3-high lateral files. | CB Add \$86 to Counterweight price for 1-high freestanding lateral modules N, E, D, P, L and H | | | | \$ 124. | |
| Security Pan  | Flat steel pan placed between modules of a lateral file stack. For use on B, C, D, E, F, G, H, L, X, N, P modules. Available through Advanced Spec-A-File. Contact Customer Care for information | PN | 1/32" | 20" or 18" | 30" | \$ 45. | |
| | | | | | 36" | \$ 51. | |
| | | | | | 42" | \$ 60. | |
| | | | | | | Note: List price upcharge is for quantity 1 security pan. | |

Meridian® Stackable™ Lateral Files Retrofit Interiors

The prices below are the retrofit prices for field installing these interiors in appropriate **existing** lateral file drawers. Option includes all parts and instructions. Be certain to specify the "part" number corresponding to the width and depth of file to be fitted.

| Description | | Part Number | | | Description | Part Number | | |
|----------------------|---------------|-------------|------------|---------------------|---------------|-------------|------------|--|
| Front-To-Back Filing | | | LIST PRICE | Side-To-Side Filing | | | LIST PRICE | |
| 9P | 30" x 18" | 9P0018 | \$ 27. | 9M ea | All 18" | 9M10018 | \$ 14. | |
| 9P | 36" x 18" | 9P3618 | \$ 27. | 9M ea | All 20" | 9M10020 | \$ 14. | |
| 9P | 42" x 18" | 9P0018 | \$ 27. | 9M set of 3 | All 18" | 9M30018 | \$ 34. | |
| 9P | 30" x 20" | 9P0020 | \$ 27. | 9M set of 3 | All 20" | 9M30020 | \$ 34. | |
| 9P | 36" x 20" | 9P3620 | \$ 27. | 9R ea | 30" x 18/20" | 9R13000 | \$ 20. | |
| 9P | 42" x 20" | 9P0020 | \$ 27. | 9R ea | 36" x 18/20" | 9R13600 | \$ 20. | |
| 9Q | 30" x 18" | 9Q3018 | \$ 44. | 9R ea | 42" x 18/20" | 9R14200 | \$ 20. | |
| 9Q | 36" x 18" | 9Q3618 | \$ 44. | 9R set of 2 | 30" x 18/20" | 9R23000 | \$ 40. | |
| 9Q | 42" x 18" | 9Q4218 | \$ 44. | 9R set of 2 | 36" x 18/20" | 9R23600 | \$ 40. | |
| 9Q | 30" x 20" | 9Q3020 | \$ 44. | 9R set of 2 | 42" x 18/20" | 9R24200 | \$ 40. | |
| 9Q | 36" x 20" | 9Q3620 | \$ 44. | 9V | 30" x 18" | 9V3018 | \$ 44. | |
| 9Q | 42" x 20" | 9Q4220 | \$ 44. | 9V | 36" x 18" | 9V3618 | \$ 44. | |
| 9C-LT | 30" x 18/20" | 9C3000LT | \$ 44. | 9V | 42" x 18" | 9V4218 | \$ 44. | |
| 9C-LT | 36" x 18/20" | 9C3600LT | \$ 44. | 9V | 30" x 20" | 9V3020 | \$ 44. | |
| 9C-LT | 42" x 18/20" | 9C4200LT | \$ 44. | 9V | 36" x 20" | 9V3620 | \$ 44. | |
| 9C-LG | 30" x 18/20" | 9C3000LG | \$ 44. | 9V | 42" x 20" | 9V4220 | \$ 44. | |
| 9C-LG | 36" x 18/20" | 9C3600LG | \$ 44. | 9X | 30" x 18/20" | 9X3000 | \$ 38. | |
| 9C-LG | 42" x 18/20" | 9C4200LG | \$ 44. | 9X | 36" x 18/20" | 9X3600 | \$ 38. | |
| 9W-LT | 30"/36" x 18" | 9W0018LT | \$ 84. | 9X | 42" x 18/20" | 9X4200 | \$ 38. | |
| 9W-LT | 42" x 18" | 9W4218LT | \$ 92. | 9Y ea | 12"Hx5"Wx16"D | 9Y10000 | \$ 39. | |
| 9W-LT | 30"/36" x 20" | 9W0020LT | \$ 84. | | | | | |
| 9W-LT | 42" x 20" | 9W4220LT | \$ 92. | | | | | |
| 9W-LG | 30" x 18" | 9W3018LG | \$ 84. | | | | | |
| 9W-LG | 36"/42" x 18" | 9W0018LG | \$ 92. | | | | | |
| 9W-LG | 30" x 20" | 9W3020LG | \$ 84. | | | | | |
| 9W-LG | 36"/42" x 20" | 9W0020LG | \$ 92. | | | | | |
| 9T ea | All 18" | 9T10018 | \$ 14. | | | | | |
| 9T ea | All 20" | 9T10020 | \$ 14. | | | | | |
| 9T set of 6 | All 18" | 9T60018 | \$ 59. | | | | | |
| 9T set of 6 | All 20" | 9T60020 | \$ 59. | | | | | |

* Specify paint color

Meridian® Stackable™ Lateral Files Card Tray

Card Tray Interior

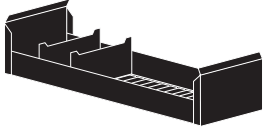

Description

Consists of removable card tray with 2 5¹/₂" dividers for card filing. To be used only with F modules. Partial bottom with open center.

Card Trays (all sizes)

LIST PRICE

\$ 57.

Card Tray Interiors

| Actual Dimension | Card Size | File Depth | Item No. | Drawer Width | Trays Per Drawer |
|--|-----------|------------|----------|--------------|------------------|
| 5 ³ / ₈ " w x 15 ³ / ₈ " d x 5 ¹ / ₄ " h | 3 x 5 | 18" | CT-3518 | 30" | 4 |
| | | | | 36" | 6 |
| | | | | 42" | 7 |
| 5 ³ / ₈ " w x 17 ³ / ₈ " d x 5 ¹ / ₄ " h | | 20" | CT-3520 | 30" | 4 |
| | | | | 36" | 6 |
| | | | | 42" | 7 |
| 6 ³ / ₈ " w x 15 ³ / ₈ " d x 5 ¹ / ₄ " h | 4 x 6 | 18" | CT-4618 | 30" | 4 |
| | | | | 36" | 5 |
| | | | | 42" | 6 |
| 6 ³ / ₈ " w x 17 ³ / ₈ " d x 5 ¹ / ₄ " h | | 20" | CT-4620 | 30" | 4 |
| | | | | 36" | 5 |
| | | | | 42" | 6 |
| 8 ³ / ₈ " w x 15 ³ / ₈ " d x 5 ¹ / ₄ " h | 5 x 8 | 18" | CT-5818 | 30" | 3 |
| | | | | 36" | 3 |
| | | | | 42" | 4 |
| 8 ³ / ₈ " w x 17 ³ / ₈ " d x 5 ¹ / ₄ " h | | 20" | CT-5820 | 30" | 3 |
| | | | | 36" | 3 |
| | | | | 42" | 4 |
| 9 ³ / ₈ " w x 15 ³ / ₈ " d x 5 ¹ / ₄ " h | 4 x 9 | 18" | CT-4918 | 30" | 2 |
| | | | | 36" | 3 |
| | | | | 42" | 4 |
| 9 ³ / ₈ " w x 17 ³ / ₈ " d x 5 ¹ / ₄ " h | | 20" | CT-4920 | 30" | 2 |
| | | | | 36" | 3 |
| | | | | 42" | 4 |

Meridian® Stackable™ Lateral Files Accessories

| | Description | D | H | W | Item Number | Quantity | LIST PRICE |
|---|--|-----|-----|---|-------------|----------|------------|
|  | Movable magnetic divider for storage of miscellaneous media. Side-to-side filing only. Available in black. | 8" | 9" | | 9Y10809 | 1 | \$ 39. |
| | | 13" | 12" | | 9Y11312 | 1 | \$ 48. |
| | | 15" | 9" | | 9Y11509 | 1 | \$ 48. |

| | | | | | | | | | | | |
|---|-----------------------|--|--|--|--|--|----|----|----------------------------------|--------|--------|
|  | File Drawer Organizer | This two-sectioned organizer fits into any file drawer arranged for letter-size filing. The removable top section stores computer disks and other small items. The bottom section stores larger items or can be divided into 3 compartments; it includes 2 vertical dividers. Finish is black umber. | | | | | 6" | 9" | 12 ⁷ / ₈ " | LG901. | \$ 77. |
|---|-----------------------|--|--|--|--|--|----|----|----------------------------------|--------|--------|

Note: This organizer does not accept letter-size file folders.

| | | | | | | |
|---|---|-----|-------------|--------|-------------|--------|
|  | Multi-media index dividers for a variety of media types including diskettes, CD-ROMs, microfiche, microfilm and index cards. Includes 2 9T front-to-back dividers and 4 index dividers. | 18" | 3" | 3" | A128-030318 | \$ 58. |
| | | 20" | 3" | 3" | A128-030320 | \$ 58. |
| | | 18" | 3" | 5" | A128-030518 | \$ 58. |
| | | 20" | 3" | 5" | A128-030520 | \$ 58. |
| | | 18" | 4" | 6" | A128-040618 | \$ 58. |
| | | 20" | 4" | 6" | A128-040620 | \$ 58. |
| | | 18" | 6" | 5" | A128-060518 | \$ 58. |
| 20" | 6" | 5" | A128-060520 | \$ 58. | | |

| | | | | | | | | | |
|---|-----------------------|--|--|--|--|--|------------|-------|--------|
|  | EnhancedAccess™ Pulls | These plastic loop-style pulls slide into the standard pulls on pedestal or lateral file drawers. They make the drawers easier to open. Package contains 1 pull and attachment hardware. | | | | | Loop Style | EAP-L | \$ 54. |
|---|-----------------------|--|--|--|--|--|------------|-------|--------|

Loop Style

For use with standard pull modules only.

Available in:

Black UMBER **BU**
Inner Tone Light **HF**
Medium Tone **MT**

Freestanding Stackable™ Lateral Files

Mobile Stackable™ Lateral Files

Credenza Arc/Bar Pull

File Tops

File Surrounds

Stackable™ Lateral File Accessories

Keyless Locks



Standard-Pull Freestanding Lateral File

26-30
26-36
26-42

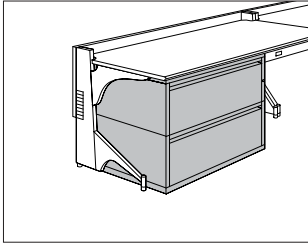

Product Information

Description

This lateral file holds letter-, legal-, and A4-size hanging files. It has standard pulls and smooth or textured steel. The file has no top or a metal, cushion, laminate, planter, or veneer top. A positive interlock system permits only 1 drawer to open at a time. 1 lock controls all drawers. The drawers can be specified with 3 dividers or with front-to-back or side-to-side filing rails for hanging files. The 5-high lateral file has 4 drawers and 1 flipper door; the flipper door includes a pullout shelf with 3 movable dividers. 5 base heights are available; all bases include adjustable glides.

Actual lateral file widths are 29⁷/₈" , 35⁷/₈" , or 41⁷/₈" ; actual depths are 17⁷/₈" or 19⁷/₈" .

Notes

For 2- or 3-high files that are not ganged or anchored, counterweights (option CB) are required. For 4- or 5-high files that are not ganged or anchored, counterweights are recommended.

When alternate drawer interior (9P, 9R, or 9M) is specified for 5-high lateral file, pullout shelf still includes 3 movable dividers.

For base height option (LB2), legs will be shipped separately.

For base height option (LB2), overall height is 3¹/₂" consisting of 1¹/₂" tube base with 2" legs.

Dimensional illustrations do not include all possible configurations.

To convert filing direction, order 1 of the following products separately:

- Front-to-back rail (9Pxxxx)
- Side-to-side rail (9Rxxxx)

See Stackable Lateral File Accessories for specific product number.

Order optional file drawer organizer (LG901) separately.

For work surface on top of 1 or more lateral files, order file top (TPL or TPV) separately.

For cushion tops TC1 and TC2, a 1" metal top is included.

Cushion top accepts Customer's Own Material (COM). Yardage is estimated for nondirectional, 54"-wide fabrics. When ordering more than 1 cushion, round up total yardage requirement to next whole yard of fabric.

Width—Yardage

30"—1.05

36"—1.22

42"—1.40

For information on multiple quantities or directional fabrics, contact COM Department. See Order Information in Appendices.

For keyed-alike locks, order lock plugs separately. See Keyed-Alike Information in Appendices.

Dimensions

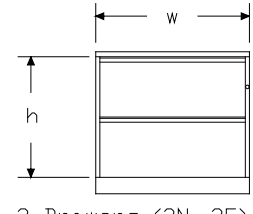
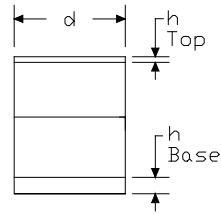

2 Drawers (2N, 2E)

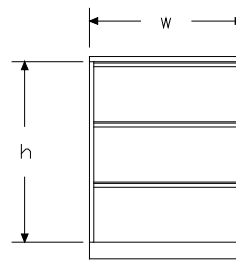

3 Drawers (3N, 3E)

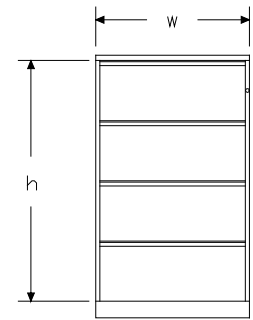

4 Drawers (4N, 4E)

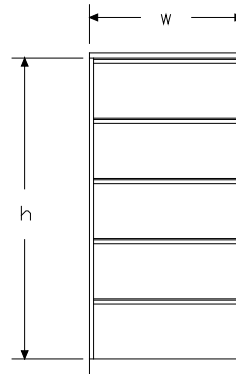

5 Drawers (5N)

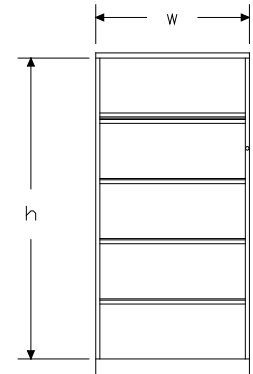

1 Flipper Door and 4 Drawers (5D, 5F)

| h | N | E | D | F |
|---|--------|--------|--------|--------|
| 2 | 23 1/2 | 26 1/4 | - | - |
| 3 | 35 1/4 | 39 3/8 | - | - |
| 4 | 47 | 52 1/2 | - | - |
| 5 | 58 3/4 | - | 60 1/8 | 65 5/8 |

All dimensions are in inches.

Standard-Pull Freestanding Lateral File *continued*

| Specification Information | |
|---------------------------|--|
| Step 1. | |
| 26- | |
| Step 2. Width | |
| 30 | 30" wide |
| 36 | 36" wide |
| 42 | 42" wide |
| Step 3. Depth | |
| 18- | 18" deep |
| 20- | 20" deep |
| Step 4. Configuration | |
| 2N | 2 11 ³ / ₄ "-high drawers |
| 3N | 3 11 ³ / ₄ "-high drawers |
| 4N | 4 11 ³ / ₄ "-high drawers |
| 5N | 5 11 ³ / ₄ "-high drawers |
| 5D | 1 13 ¹ / ₈ "-high flipper door and 4 11 ³ / ₄ "-high drawers |
| 2E | 2 13 ¹ / ₈ "-high drawers |
| 3E | 3 13 ¹ / ₈ "-high drawers |
| 4E | 4 13 ¹ / ₈ "-high drawers |
| 5F | 1 13 ¹ / ₈ "-high flipper door and 4 13 ¹ / ₈ "-high drawers |

| Prices for Steps 1-4. | | | | | | | |
|-----------------------|------------|-----------|-----------|-----------|-----------|-----------|-----------|
| | | 2N | 3N | 4N | 5N | 5D | 2E |
| 26-30 | 18- | \$802 | 1115 | 1430 | 1744 | 1789 | 802 |
| | 20- | \$802 | 1115 | 1430 | 1744 | 1789 | 802 |
| 26-36 | 18- | \$889 | 1232 | 1576 | 1919 | 1963 | 889 |
| | 20- | \$889 | 1232 | 1576 | 1919 | 1963 | 889 |
| 26-42 | 18- | \$1008 | 1394 | 1781 | 2170 | 2212 | 1008 |
| | 20- | \$1008 | 1394 | 1781 | 2170 | 2212 | 1008 |
| | | | | | 3E | 4E | 5F |
| 26-30 | 18- | | | | \$1115 | 1430 | 1789 |
| | 20- | | | | \$1115 | 1430 | 1789 |
| 26-36 | 18- | | | | \$1232 | 1576 | 1963 |
| | 20- | | | | \$1232 | 1576 | 1963 |
| 26-42 | 18- | | | | \$1394 | 1781 | 2212 |
| | 20- | | | | \$1394 | 1781 | 2212 |

| Step 5. Paint/Steel Type | | |
|--------------------------|--------------------------------|-------|
| SS | smooth paint on smooth steel | +\$0 |
| TS | smooth paint on textured steel | +\$35 |
| XS | textured paint on smooth steel | +\$0 |

| Step 6. Surface Finish | | |
|---|--|------|
| Nonmetallic Paint | | |
| <i>For smooth paint on smooth steel (SS) or smooth paint on textured steel (TS)</i> | | |
| 8Q | folkstone grey | +\$0 |
| 91 | white | +\$0 |
| 98 | studio white A | +\$0 |
| 9J | sparrow | +\$0 |
| BU | black umber | +\$0 |
| CL | cool grey neutral | +\$0 |
| G2 | graphite satin | +\$0 |
| HF | inner tone light | +\$0 |
| HT | inner tone | +\$0 |
| LT | light tone | +\$0 |
| LU | soft white | +\$0 |
| MT | medium tone | +\$0 |
| SG | slate grey | +\$0 |
| WA | wheat | +\$0 |
| WL | sandstone | +\$0 |

| Metallic Paint | | |
|---|--------------------|-------|
| <i>For smooth paint on smooth steel (SS) or smooth paint on textured steel (TS)</i> | | |
| 1209 | platinum | +\$65 |
| 1210 | hematite | +\$65 |
| 1212 | bronzite | +\$65 |
| CN | metallic champagne | +\$65 |
| EH | metallic bronze | +\$65 |
| MS | metallic silver | +\$65 |

| Sand Texture Paint | | |
|--|--|------|
| <i>For textured paint on smooth steel (XS)</i> | | |
| 98 | studio white A | +\$0 |

| Bright Sand Texture Paint | | |
|--|-------------------|------|
| <i>For textured paint on smooth steel (XS)</i> | | |
| 91 | white | +\$0 |
| CL | cool grey neutral | +\$0 |
| G1 | graphite | +\$0 |
| WN | warm grey neutral | +\$0 |

Standard-Pull Freestanding Lateral File *continued*

| Step 7. Top | | |
|-------------|--|--------|
| NT | no top | +\$0 |
| T1 | 1"-high painted metal top with squared edge | +\$0 |
| T2 | 1 1/4"-high painted metal top with squared edge | +\$0 |
| T3 | 1 1/4"-high painted metal top with radius edge | +\$63 |
| TL | 1 1/4"-high laminate top with vinyl edge | +\$72 |
| TR | 1 1/4"-high recut veneer top A | +\$147 |
| TF | 1 1/4"-high wood veneer top A | +\$152 |
| T7 | 6 1/2"-high planter top | +\$196 |
| D1 | 6 1/2"-high full dome, side-to-side | +\$267 |
| H1 | 6 1/2"-high half dome, sloping left | +\$267 |
| H2 | 6 1/2"-high half dome, sloping right | +\$267 |
| TV1 | 1 1/8"-high wood veneer top and wood composite edge with oversail front A | +\$314 |
| TC1 | 1" cushion top | +\$386 |
| TC2 | 2" cushion top | +\$386 |

Step 8. Veneer Top Finish

Wood Veneer

For 1 1/8"-high wood veneer top and wood composite edge with oversail front (TV1)

| | | |
|-----------|----------------------------|-------|
| 40 | dark brown walnut A | +\$28 |
| ED | aged cherry A | +\$28 |
| EK | medium red walnut A | +\$28 |
| ET | clear on ash A | +\$28 |
| EU | oak on ash A | +\$28 |
| EV | walnut on ash A | +\$28 |
| UL | natural maple A | +\$28 |
| UX | walnut on cherry A | +\$28 |

Wood Veneer

For 1 1/4"-high wood veneer top (TF)

| | | |
|-----------|-----------------------------|-------|
| 2U | light brown walnut A | +\$28 |
| 40 | dark brown walnut A | +\$28 |
| ED | aged cherry A | +\$28 |
| EK | medium red walnut A | +\$28 |
| ET | clear on ash A | +\$28 |
| EU | oak on ash A | +\$28 |
| EV | walnut on ash A | +\$28 |
| UL | natural maple A | +\$28 |
| UX | walnut on cherry A | +\$28 |

| Recut Veneer | | |
|--|------------------------|------|
| <i>For 1 1/4"-high recut veneer top (TR)</i> | | |
| RA | light ash A | +\$0 |
| RK | mahogany dark A | +\$0 |
| RM | mahogany A | +\$0 |

Step 9. Top Finish

For 1 1/4"-high laminate top with vinyl edge (TL)

Solid-Color Laminate

| | | |
|-----------|-------------------|------|
| 8Q | folkstone grey | +\$0 |
| 91 | white | +\$0 |
| 98 | studio white | +\$0 |
| CL | cool grey neutral | +\$0 |
| HF | inner tone light | +\$0 |
| HT | inner tone | +\$0 |
| LT | light tone | +\$0 |
| LU | soft white | +\$0 |
| WL | sandstone | +\$0 |
| WN | warm grey neutral | +\$0 |

Linen Laminate

| | | |
|------------|---------------|------|
| LBM | crisp linen | +\$0 |
| LBN | classic linen | +\$0 |
| LBP | casual linen | +\$0 |

Mesh Laminate

| | | |
|------------|-------------|------|
| LBK | pewter mesh | +\$0 |
| LBL | steel mesh | +\$0 |

Twill Laminate

| | | |
|------------|----------------|------|
| LBF | neutral twill | +\$0 |
| LBG | sarum twill | +\$0 |
| LBH | earthen twill | +\$0 |
| LBJ | graphite twill | +\$0 |
| LBQ | white twill | +\$0 |

Standard-Pull Freestanding Lateral File *continued*

Meridian® Freestanding Stackable™ Lateral Files

| Wood-Grain Laminate | | |
|---------------------|--------------------|------|
| HM | natural maple | +\$0 |
| HP | light anigre | +\$0 |
| LA | light ash | +\$0 |
| LBA | clear on ash | +\$0 |
| LBB | oak on ash | +\$0 |
| LBC | walnut on ash | +\$0 |
| LBD | dark brown walnut | +\$0 |
| LBE | medium red walnut | +\$0 |
| LM | mahogany | +\$0 |
| 76 | light brown walnut | +\$0 |
| HX | aged cherry | +\$0 |
| HY | walnut on cherry | +\$0 |

| Zephyr Laminate | | |
|-----------------|--------|------|
| 28 | canyon | +\$0 |
| 29 | misted | +\$0 |

| Step 10. Edge Finish | | |
|--|--------------------|------|
| <i>For 1 1/4"-high laminate top with vinyl edge (TL)</i> | | |
| 28 | canyon | +\$0 |
| 29 | misted | +\$0 |
| 76 | light brown walnut | +\$0 |
| 8Q | folkstone grey | +\$0 |
| 91 | white | +\$0 |
| 98 | studio white | +\$0 |
| BU | black umber | +\$0 |
| CL | cool grey neutral | +\$0 |
| G2 | graphite satin | +\$0 |
| HF | inner tone light | +\$0 |
| HM | natural maple | +\$0 |
| HP | light anigre | +\$0 |
| HT | inner tone | +\$0 |
| HX | aged cherry | +\$0 |
| HY | walnut on cherry | +\$0 |
| LA | light ash | +\$0 |
| LBA | clear on ash | +\$0 |
| LBB | oak on ash | +\$0 |
| LBC | walnut on ash | +\$0 |
| LBD | dark brown walnut | +\$0 |
| LBE | medium red walnut | +\$0 |
| LBK | pewter mesh | +\$0 |
| LBL | steel mesh | +\$0 |
| LBM | crisp linen | +\$0 |
| LBN | classic linen | +\$0 |
| LBP | casual linen | +\$0 |
| LBF | neutral twill | +\$0 |

| | | |
|------------|-------------------|------|
| LBG | sarum twill | +\$0 |
| LBH | earthen twill | +\$0 |
| LBJ | graphite twill | +\$0 |
| LBQ | white twill | +\$0 |
| LM | mahogany | +\$0 |
| LU | soft white | +\$0 |
| MT | medium tone | +\$0 |
| SG | slate grey | +\$0 |
| WA | wheat | +\$0 |
| WL | sandstone | +\$0 |
| WN | warm grey neutral | +\$0 |

Step 11. Cushion Top Fabric

For 1" cushion top (TC1) or 2" cushion top (TC2)

See application chart and textiles list for fabric usage and numbers.

First 2 digits of number indicate fabric line; remaining digit(s) indicate fabric color.

| | |
|----------------------------|---------|
| Price Category 1 | +\$0 |
| Price Category 2 | +\$68 |
| Price Category 3 | +\$82 |
| Price Category 4 | +\$101 |
| Price Category 5 | +\$120 |
| Price Category 7 A | +\$137 |
| Price Category 9 | +\$950 |
| Price Category (Geiger) 10 | +\$1050 |
| Price Category B | +\$47 |
| Price Category C | +\$65 |
| Price Category D | +\$82 |
| Price Category E | +\$99 |
| Price Category F | +\$141 |
| Price Category G | +\$166 |
| Price Category H | +\$204 |
| Price Category I | +\$264 |
| Price Category J | +\$276 |
| Price Category K | +\$310 |

Step 12. Lock

| | | |
|-----------|---------------------------|------|
| KA | keyed alike | +\$0 |
| KC | keyed differently, chrome | +\$0 |
| KD | keyed differently, black | +\$0 |

Standard-Pull Freestanding Lateral File *continued*

| Step 13. Base Height | | |
|----------------------|------------------------|-------|
| B1 | 1"-high base | +\$0 |
| B2 | 1½"-high base | +\$0 |
| B3 | 2¼"-high base | +\$0 |
| B4 | 3¼"-high base | +\$0 |
| BA | 1"-high recessed base | +\$33 |
| BB | 1½"-high recessed base | +\$33 |
| BC | 2¼"-high recessed base | +\$33 |
| BD | 3¼"-high recessed base | +\$33 |
| B5 | 4¼"-high base | +\$33 |
| LB2 | 1½" leg base | +\$33 |

| Step 14. Leg <i>For 1½" leg base (LB2)</i> | | |
|---|--------------------|--------|
| DD | 2"-high canvas leg | +\$122 |

| Step 15. Leg Finish | | |
|---------------------|-------------------|------|
| 91 | white | +\$0 |
| 98 | studio white | +\$0 |
| CL | cool grey neutral | +\$0 |
| G1 | graphite | +\$0 |
| WN | warm grey neutral | +\$0 |

| Metallic Paint | | |
|----------------|--------------------|-------|
| CN | metallic champagne | +\$10 |
| EH | metallic bronze | +\$10 |
| MS | metallic silver | +\$10 |

| Step 16. Counterweight | | |
|------------------------|--|--------|
| NO | no counterweight (must gang or anchor) | +\$0 |
| CB | counterweight (recommended) | +\$119 |

| Step 17. Drawer Interior | | |
|--------------------------|---------------------------|------|
| 9M | 3 dividers | +\$0 |
| 9P | front-to-back filing rail | +\$0 |
| 9R | side-to-side filing rail | +\$0 |

Arc-Pull Freestanding Lateral File

2A-30
2A-36
2A-42
2D-30
2D-36
2D-42

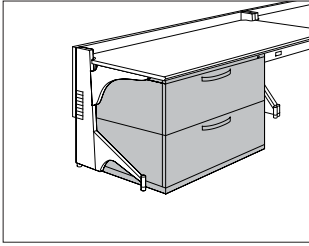

Product Information

Description

This lateral file holds letter-, legal-, and A4-size hanging files. It has arc pulls and smooth or textured steel. The file has no top or a metal, cushion, laminate, planter, or veneer top. A positive interlock system permits only 1 drawer to open at a time. 1 lock controls all drawers. The drawers can be specified with 3 dividers or with front-to-back or side-to-side filing rails for hanging files. 5 base heights are available; all bases include adjustable glides.

Actual lateral file widths are $29\frac{7}{8}$ " , $35\frac{7}{8}$ " , or $41\frac{7}{8}$ " ; actual depths are $17\frac{7}{8}$ " or $19\frac{7}{8}$ " .

Notes

For 2- or 3-high files that are not ganged or anchored, counterweights (option CB) are required. For 4- or 5-high files that are not ganged or anchored, counterweights are recommended.

For base height option (LB2), legs will be shipped separately.

For base height option (LB2), overall height is $3\frac{1}{2}$ " consisting of $1\frac{1}{2}$ " tube base with 2" legs.

Dimensional illustrations do not include all possible configurations.

To convert filing direction, order 1 of the following products separately:

- Front-to-back rail (gPxxxx)
- Side-to-side rail (gRxxxx)

See Stackable Lateral File Accessories for specific product number.

Order optional file drawer organizer (LG901) separately.

For work surface on top of 1 or more lateral files, order file top (TPL or TPV) separately.

No lock option (NL) can only be specified on files with no top (NT), dome tops (D1, H1, or H2), planter top (T7), laminate tops (TL), or veneer top (TV1).

For cushion tops TC1 and TC2, a 1" metal top is included.

Grain direction is vertical for veneer-front lateral files.

Cushion top accepts Customer's Own Material (COM). Yardage is estimated for nondirectional, 54"-wide fabrics. When ordering more than 1 cushion, round up total yardage requirement to next whole yard of fabric.

Width—Yardage

30"—1.05

36"—1.22

42"—1.40

For information on multiple quantities or directional fabrics, contact COM Department. See Order Information in Appendices.

For keyed-alike locks, order lock plugs separately. See Keyed-Alike Information in Appendices.

The arc pull conforms to guidelines of the Americans with Disabilities Act (ADA).

Dimensions

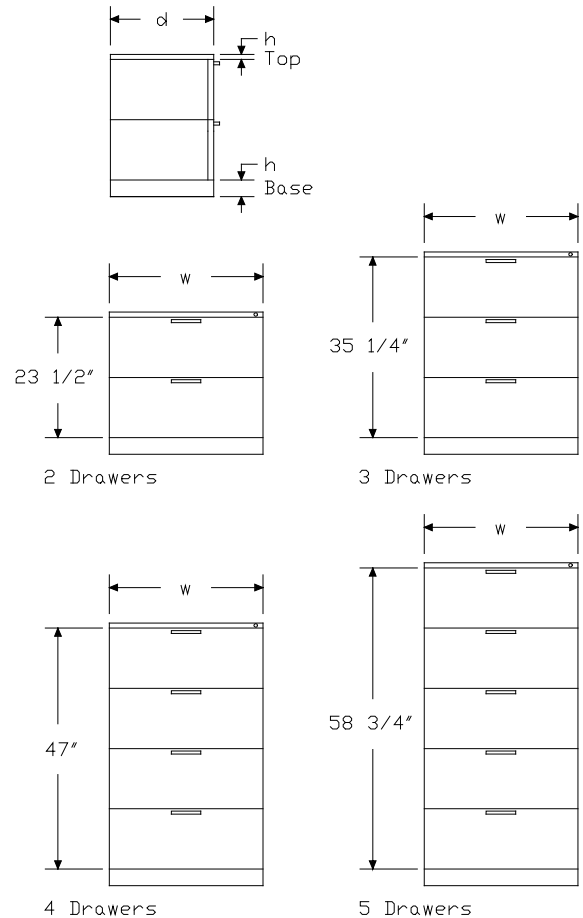

Arc-Pull Freestanding Lateral File

continued

Specification Information

Step 1.

2

Step 2. Front Material

- D-** painted metal front
- A-** veneer front A

Step 3. Width

- 30** 30" wide
- 36** 36" wide
- 42** 42" wide

Step 4. Depth

- 18-** 18" deep
- 20-** 20" deep

Step 5. Configuration

- 2N** 2 drawers
- 3N** 3 drawers
- 4N** 4 drawers
- 5N** 5 drawers

Prices for Steps 1-5.

| | 2N | 3N | 4N | 5N |
|------------------|-----------|-----------|-----------|-----------|
| 2D-30 18- | \$843 | 1156 | 1471 | 1785 |
| 20- | \$843 | 1156 | 1471 | 1785 |
| 2D-36 18- | \$931 | 1274 | 1618 | 1961 |
| 20- | \$931 | 1274 | 1618 | 1961 |
| 2D-42 18- | \$1049 | 1435 | 1823 | 2211 |
| 20- | \$1049 | 1435 | 1823 | 2211 |
| 2A-30 18- | \$1170 | 1650 | 2126 | 2607 |
| 20- | \$1170 | 1650 | 2126 | 2607 |
| 2A-36 18- | \$1324 | 1865 | 2406 | 2946 |
| 20- | \$1324 | 1865 | 2406 | 2946 |
| 2A-42 18- | \$1504 | 2119 | 2737 | 3351 |
| 20- | \$1504 | 2119 | 2737 | 3351 |

Step 6. Paint/Steel Type

- SS** smooth paint on smooth steel +\$0
- TS** smooth paint on textured steel +\$35
- XS** textured paint on smooth steel +\$0

Step 7. Surface Finish

Nonmetallic Paint

For smooth paint on smooth steel (SS) or smooth paint on textured steel (TS)

| | | |
|-----------|--|------|
| 8Q | folkstone grey | +\$0 |
| 91 | white | +\$0 |
| 98 | studio white A | +\$0 |
| 9J | sparrow | +\$0 |
| BU | black umber | +\$0 |
| G2 | graphite satin | +\$0 |
| HF | inner tone light | +\$0 |
| HT | inner tone | +\$0 |
| LT | light tone | +\$0 |
| LU | soft white | +\$0 |
| MT | medium tone | +\$0 |
| SG | slate grey | +\$0 |
| WA | wheat | +\$0 |
| WL | sandstone | +\$0 |

Metallic Paint

For smooth paint on smooth steel (SS) or smooth paint on textured steel (TS)

| | | |
|-------------|--------------------|-------|
| 1209 | platinum | +\$65 |
| 1210 | hematite | +\$65 |
| 1212 | bronzite | +\$65 |
| CN | metallic champagne | +\$65 |
| EH | metallic bronze | +\$65 |
| MS | metallic silver | +\$65 |

Sand Texture Paint

For textured paint on smooth steel (XS)

| | | |
|-----------|--|------|
| 98 | studio white A | +\$0 |
|-----------|--|------|

Bright Sand Texture Paint

For textured paint on smooth steel (XS)

| | | |
|-----------|-------------------|------|
| 91 | white | +\$0 |
| CL | cool grey neutral | +\$0 |
| G1 | graphite | +\$0 |
| WN | warm grey neutral | +\$0 |

Arc-Pull Freestanding Lateral File

continued

Meridian® Freestanding Stackable™ Lateral Files

Step 8. Top

For painted metal front (D-)

| | | |
|------------|--|--------|
| NT | no top | +\$0 |
| T1 | 1"-high painted metal top with squared edge | +\$0 |
| T2 | 1 1/4"-high painted metal top with squared edge | +\$0 |
| T3 | 1 1/4"-high painted metal top with radius edge | +\$63 |
| TL | 1 1/4"-high laminate top with vinyl edge | +\$72 |
| TR | 1 1/4"-high recut veneer top <input type="checkbox"/> A | +\$147 |
| TF | 1 1/4"-high wood veneer top <input type="checkbox"/> A | +\$152 |
| T7 | 6 1/2"-high planter top | +\$196 |
| D1 | 6 1/2"-high full dome, side-to-side | +\$267 |
| H1 | 6 1/2"-high half dome, sloping left | +\$267 |
| H2 | 6 1/2"-high half dome, sloping right | +\$267 |
| TV1 | 1 1/8"-high wood veneer top and wood composite edge with oversail front <input type="checkbox"/> A | +\$314 |
| TC1 | 1" cushion top | +\$386 |
| TC2 | 2" cushion top | +\$386 |

For veneer front (A-)

| | | |
|------------|--|--------|
| NT | no top | +\$0 |
| T1 | 1"-high painted metal top with squared edge | +\$0 |
| T2 | 1 1/4"-high painted metal top with squared edge | +\$0 |
| T3 | 1 1/4"-high painted metal top with radius edge | +\$63 |
| TL | 1 1/4"-high laminate top with vinyl edge | +\$72 |
| TF | 1 1/4"-high wood veneer top <input type="checkbox"/> A | +\$152 |
| T7 | 6 1/2"-high planter top | +\$196 |
| D1 | 6 1/2"-high full dome, side-to-side | +\$267 |
| H1 | 6 1/2"-high half dome, sloping left | +\$267 |
| H2 | 6 1/2"-high half dome, sloping right | +\$267 |
| TV1 | 1 1/8"-high wood veneer top and wood composite edge with oversail front <input type="checkbox"/> A | +\$314 |
| TC1 | 1" cushion top | +\$386 |
| TC2 | 2" cushion top | +\$386 |

Step 9.

Veneer Top Finish: Wood Veneer

For 1 1/4"-high wood veneer top (TF)

| | | |
|-----------|---|-------|
| 2U | light brown walnut <input type="checkbox"/> A | +\$28 |
| 40 | dark brown walnut <input type="checkbox"/> A | +\$28 |
| ED | aged cherry <input type="checkbox"/> A | +\$28 |
| EK | medium red walnut <input type="checkbox"/> A | +\$28 |
| ET | clear on ash <input type="checkbox"/> A | +\$28 |
| EU | oak on ash <input type="checkbox"/> A | +\$28 |
| EV | walnut on ash <input type="checkbox"/> A | +\$28 |
| UL | natural maple <input type="checkbox"/> A | +\$28 |
| UX | walnut on cherry <input type="checkbox"/> A | +\$28 |

Veneer Front Finish: Wood Veneer

For no top (NT), 1"-high painted metal top with squared edge (T1), 1 1/4"-high painted metal top with squared edge (T2), 1 1/4"-high painted metal top with radius edge (T3), 1 1/4"-high laminate top with vinyl edge (TL), 6 1/2"-high planter top (T7), 6 1/2"-high full dome, side-to-side (D1), 6 1/2"-high half dome, sloping left (H1), 6 1/2"-high half dome, sloping right (H2), 1" cushion top (TC1), or 2" cushion top (TC2)

| | | |
|-----------|---|-------|
| 2U | light brown walnut <input type="checkbox"/> A | +\$56 |
| 40 | dark brown walnut <input type="checkbox"/> A | +\$56 |
| ED | aged cherry <input type="checkbox"/> A | +\$56 |
| EK | medium red walnut <input type="checkbox"/> A | +\$56 |
| ET | clear on ash <input type="checkbox"/> A | +\$56 |
| EU | oak on ash <input type="checkbox"/> A | +\$56 |
| EV | walnut on ash <input type="checkbox"/> A | +\$56 |
| UL | natural maple <input type="checkbox"/> A | +\$56 |
| UX | walnut on cherry <input type="checkbox"/> A | +\$56 |

Veneer Top Finish: Wood Veneer

For 1 1/8"-high wood veneer top and wood composite edge with oversail front (TV1)

| | | |
|-----------|--|-------|
| 40 | dark brown walnut <input type="checkbox"/> A | +\$28 |
| ED | aged cherry <input type="checkbox"/> A | +\$28 |
| EK | medium red walnut <input type="checkbox"/> A | +\$28 |
| ET | clear on ash <input type="checkbox"/> A | +\$28 |
| EU | oak on ash <input type="checkbox"/> A | +\$28 |
| EV | walnut on ash <input type="checkbox"/> A | +\$28 |
| UL | natural maple <input type="checkbox"/> A | +\$28 |
| UX | walnut on cherry <input type="checkbox"/> A | +\$28 |

Arc-Pull Freestanding Lateral File

continued

Veneer Front/Top Finish: Wood Veneer
 For 1¹/₈"-high wood veneer top and wood composite edge with oversail front (TV₁)

| | | |
|-----------|----------------------------|-------|
| 40 | dark brown walnut A | +\$56 |
| ED | aged cherry A | +\$56 |
| EK | medium red walnut A | +\$56 |
| ET | clear on ash A | +\$56 |
| EU | oak on ash A | +\$56 |
| EV | walnut on ash A | +\$56 |
| UL | natural maple A | +\$56 |
| UX | walnut on cherry A | +\$56 |

Veneer Top Finish: Recut Veneer
 For 1¹/₄"-high recut veneer top (TR)

| | | |
|-----------|------------------------|------|
| RA | light ash A | +\$0 |
| RK | mahogany dark A | +\$0 |
| RM | mahogany A | +\$0 |

Veneer Front/Top Finish: Wood Veneer
 For 1¹/₄"-high wood veneer top (TF)

| | | |
|-----------|-----------------------------|-------|
| 2U | light brown walnut A | +\$56 |
| 40 | dark brown walnut A | +\$56 |
| ED | aged cherry A | +\$56 |
| EK | medium red walnut A | +\$56 |
| ET | clear on ash A | +\$56 |
| EU | oak on ash A | +\$56 |
| EV | walnut on ash A | +\$56 |
| UL | natural maple A | +\$56 |
| UX | walnut on cherry A | +\$56 |

Step 10. Top Finish
 For 1¹/₄"-high laminate top with vinyl edge (TL)

Solid-Color Laminate

| | | |
|-----------|-------------------|------|
| 8Q | folkstone grey | +\$0 |
| 91 | white | +\$0 |
| 98 | studio white | +\$0 |
| CL | cool grey neutral | +\$0 |
| HF | inner tone light | +\$0 |
| HT | inner tone | +\$0 |
| LT | light tone | +\$0 |
| LU | soft white | +\$0 |
| WL | sandstone | +\$0 |
| WN | warm grey neutral | +\$0 |

Linen Laminate

| | | |
|------------|---------------|------|
| LBM | crisp linen | +\$0 |
| LBN | classic linen | +\$0 |
| LBP | casual linen | +\$0 |

Mesh Laminate

| | | |
|------------|-------------|------|
| LBK | pewter mesh | +\$0 |
| LBL | steel mesh | +\$0 |

Twill Laminate

| | | |
|------------|----------------|------|
| LBF | neutral twill | +\$0 |
| LBG | sarum twill | +\$0 |
| LBH | earthen twill | +\$0 |
| LBJ | graphite twill | +\$0 |
| LBQ | white twill | +\$0 |

Wood-Grain Laminate

| | | |
|------------|--------------------|------|
| HM | natural maple | +\$0 |
| HP | light anigre | +\$0 |
| LA | light ash | +\$0 |
| LBA | clear on ash | +\$0 |
| LBB | oak on ash | +\$0 |
| LBC | walnut on ash | +\$0 |
| LBD | dark brown walnut | +\$0 |
| LBE | medium red walnut | +\$0 |
| LM | mahogany | +\$0 |
| 76 | light brown walnut | +\$0 |
| HX | aged cherry | +\$0 |
| HY | walnut on cherry | +\$0 |

Zephyr Laminate

| | | |
|-----------|--------|------|
| 28 | canyon | +\$0 |
| 29 | misted | +\$0 |

Step 11. Edge Finish
 For 1¹/₄"-high laminate top with vinyl edge (TL)

| | | |
|-----------|--------------------|------|
| 28 | canyon | +\$0 |
| 29 | misted | +\$0 |
| 76 | light brown walnut | +\$0 |
| 8Q | folkstone grey | +\$0 |
| 91 | white | +\$0 |
| 98 | studio white | +\$0 |
| BU | black umber | +\$0 |
| CL | cool grey neutral | +\$0 |
| G2 | graphite satin | +\$0 |
| HF | inner tone light | +\$0 |
| HM | natural maple | +\$0 |

Meridian® Freestanding Stackable™ Lateral Files

Arc-Pull Freestanding Lateral File

continued

Meridian® Freestanding Stackable™ Lateral Files

| | | |
|------------|-------------------|------|
| HP | light anigre | +\$0 |
| HT | inner tone | +\$0 |
| HX | aged cherry | +\$0 |
| HY | walnut on cherry | +\$0 |
| LA | light ash | +\$0 |
| LBA | clear on ash | +\$0 |
| LBB | oak on ash | +\$0 |
| LBC | walnut on ash | +\$0 |
| LBD | dark brown walnut | +\$0 |
| LBE | medium red walnut | +\$0 |
| LBK | pewter mesh | +\$0 |
| LBL | steel mesh | +\$0 |
| LBM | crisp linen | +\$0 |
| LBN | classic linen | +\$0 |
| LBP | casual linen | +\$0 |
| LBF | neutral twill | +\$0 |
| LBG | sarum twill | +\$0 |
| LBH | earthen twill | +\$0 |
| LBJ | graphite twill | +\$0 |
| LBQ | white twill | +\$0 |
| LM | mahogany | +\$0 |
| LU | soft white | +\$0 |
| MT | medium tone | +\$0 |
| SG | slate grey | +\$0 |
| WA | wheat | +\$0 |
| WL | sandstone | +\$0 |
| WN | warm grey neutral | +\$0 |

Step 12. Cushion Top Fabric

For 1" cushion top (TC1) or 2" cushion top (TC2)

See textiles list for fabric numbers. First 2 digits of number indicate fabric line; remaining digit(s) indicate fabric color.

| | |
|--|---------|
| Price Category 1 | +\$0 |
| Price Category 2 | +\$68 |
| Price Category 3 | +\$82 |
| Price Category 4 | +\$101 |
| Price Category 5 | +\$120 |
| Price Category 7 A | +\$137 |
| Price Category 9 | +\$950 |
| Price Category (Geiger) 10 | +\$1050 |
| Price Category B | +\$47 |
| Price Category C | +\$65 |
| Price Category D | +\$82 |
| Price Category E | +\$99 |
| Price Category F | +\$141 |
| Price Category G | +\$166 |
| Price Category H | +\$204 |
| Price Category I | +\$264 |
| Price Category J | +\$276 |
| Price Category K | +\$310 |

Step 13. Lock

For no top (NT), 1 1/4"-high laminate top with vinyl edge (TL), 6 1/2"-high planter top (T7), 6 1/2"-high full dome, side-to-side (D1), 6 1/2"-high half dome, sloping left (H1), 6 1/2"-high half dome, sloping right (H2), or 1 1/8"-high wood veneer top and wood composite edge with oversail front (TV1)

| | | |
|-----------|---------|-------|
| NL | no lock | -\$30 |
|-----------|---------|-------|

For 1"-high painted metal top with squared edge (T1), 1 1/4"-high painted metal top with squared edge (T2), 1 1/4"-high painted metal top with radius edge (T3), 1 1/4"-high recut veneer top (TR), 1 1/4"-high wood veneer top (TF), 1" cushion top (TC1), or 2" cushion top (TC2)

| | | |
|-----------|---------------------------|------|
| KA | keyed alike | +\$0 |
| KC | keyed differently, chrome | +\$0 |
| KD | keyed differently, black | +\$0 |

Step 14. Pull Finish

| | | |
|-----------|----------------|------|
| NH | brushed nickel | +\$0 |
| NK | black nickel | +\$0 |

Arc-Pull Freestanding Lateral File

continued

| Step 15. Base Height | | |
|----------------------|------------------------|-------|
| B1 | 1"-high base | +\$0 |
| B2 | 1½"-high base | +\$0 |
| B3 | 2¼"-high base | +\$0 |
| B4 | 3¼"-high base | +\$0 |
| BA | 1"-high recessed base | +\$33 |
| BB | 1½"-high recessed base | +\$33 |
| BC | 2¼"-high recessed base | +\$33 |
| BD | 3¼"-high recessed base | +\$33 |
| B5 | 4¼"-high base | +\$33 |
| LB2 | 1½" leg base | +\$33 |

| Step 16. Leg | | |
|-------------------------------|--------------------|--------|
| <i>For 1½" leg base (LB2)</i> | | |
| DD | 2"-high canvas leg | +\$122 |

| Step 17. Leg Finish | | |
|---------------------|-------------------|------|
| 91 | white | +\$0 |
| CL | cool grey neutral | +\$0 |
| G1 | graphite | +\$0 |
| WN | warm grey neutral | +\$0 |

| Metallic Paint | | |
|----------------|--------------------|-------|
| CN | metallic champagne | +\$10 |
| EH | metallic bronze | +\$10 |
| MS | metallic silver | +\$10 |

| Step 18. Counterweight | | |
|------------------------|--|--------|
| NO | no counterweight (must gang or anchor) | +\$0 |
| CB | counterweight (recommended) | +\$119 |

| Step 19. Drawer Interior | | |
|--------------------------|---------------------------|------|
| 9P | front-to-back filing rail | +\$0 |
| 9R | side-to-side filing rail | +\$0 |
| 9M | 3 dividers | +\$0 |

Bar-Pull Freestanding Lateral File

2KP-3
2KP-4
2KV-3
2KV-4

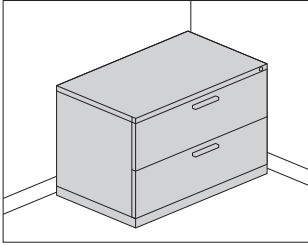

Product Information

Description

This lateral file holds letter-, legal-, and A4-size hanging files. It has bar pulls and smooth or textured steel. The file has no top or a metal, cushion, laminate, planter, or veneer top. A positive interlock system permits only 1 drawer to open at a time. 1 lock controls all drawers. The drawers can be specified with 3 dividers or with front-to-back or side-to-side filing rails for hanging files. 5 base heights are available; all bases include adjustable glides.

Actual lateral file widths are $29\frac{7}{8}$ " , $35\frac{7}{8}$ " , or $41\frac{7}{8}$ " ; actual depths are $17\frac{7}{8}$ " or $19\frac{7}{8}$ " .

Notes

For 2- or 3-high files that are not ganged or anchored, counterweights (option CB) are required. For 4- or 5-high files that are not ganged or anchored, counterweights are recommended.

For base height option (LB2), legs will be shipped separately.

For base height option (LB2), overall height is $3\frac{1}{2}$ " consisting of $1\frac{1}{2}$ " tube base with 2" legs.

Dimensional illustrations do not include all possible configurations.

To convert filing direction, order 1 of the following products separately:

- Front-to-back rail (gPxxxx)
- Side-to-side rail (gRxxxx)

See Stackable Lateral File Accessories for specific product number.

Order optional file drawer organizer (LG901) separately.

For work surface on top of 1 or more lateral files, order file top (TPL or TPV) separately.

No lock option (NL) can only be specified on files with no top (NT), dome tops (D1, H1, or H2), planter top (T7), laminate tops (TL), or veneer top (TV1).

For cushion tops TC1 and TC2, a 1" metal top is included.

Grain direction is vertical for veneer-front lateral files.

Cushion top accepts Customer's Own Material (COM). Yardage is estimated for nondirectional, 54"-wide fabrics. When ordering more than 1 cushion, round up total yardage requirement to next whole yard of fabric.

Width—Yardage

30"—1.05

36"—1.22

42"—1.40

For information on multiple quantities or directional fabrics, contact COM Department. See Order Information in Appendices.

For keyed-alike locks, order lock plugs separately. See Keyed-Alike Information in Appendices.

Dimensions

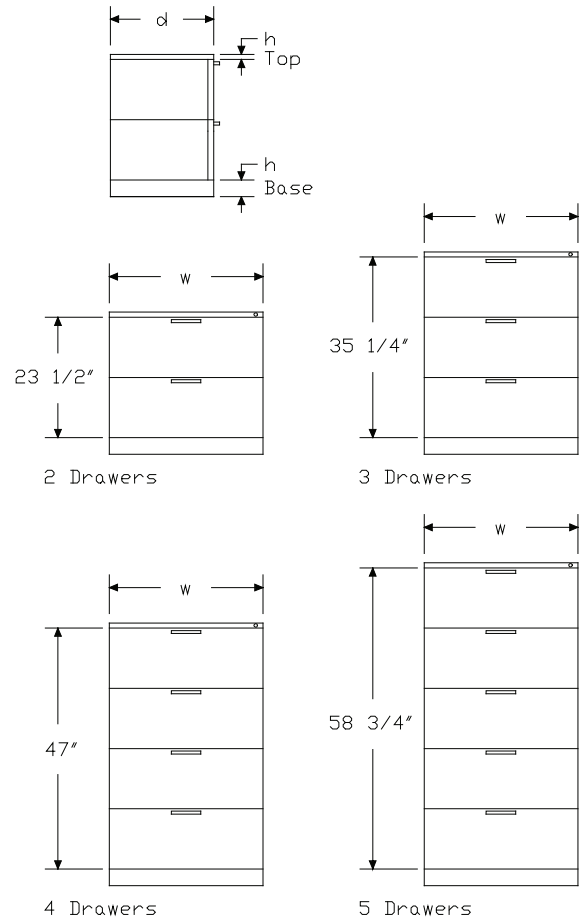

Bar-Pull Freestanding Lateral File

continued

Meridian® Freestanding Stackable™ Lateral Files

Specification Information

Step 1.

2K

Step 2. Front Material

P- painted metal front
V- veneer front

Step 3. Width

30 30" wide
36 36" wide
42 42" wide

Step 4. Depth

18- 18" deep
20- 20" deep

Step 5. Configuration

2N 2 drawers
3N 3 drawers
4N 4 drawers
5N 5 drawers

Prices for Steps 1-5.

| | 2N | 3N | 4N | 5N |
|-------------------|-----------|-----------|-----------|-----------|
| 2KP-30 18- | \$842 | 1156 | 1471 | 1785 |
| 20- | \$842 | 1156 | 1471 | 1785 |
| 2KP-36 18- | \$931 | 1274 | 1618 | 1961 |
| 20- | \$931 | 1274 | 1618 | 1961 |
| 2KP-42 18- | \$1049 | 1435 | 1823 | 2212 |
| 20- | \$1049 | 1435 | 1823 | 2212 |
| 2KV-30 18- | \$1170 | 1650 | 2237 | 2607 |
| 20- | \$1170 | 1650 | 2237 | 2607 |
| 2KV-36 18- | \$1324 | 1865 | 2406 | 2946 |
| 20- | \$1324 | 1865 | 2406 | 2946 |
| 2KV-42 18- | \$1504 | 2119 | 2737 | 3351 |
| 20- | \$1504 | 2119 | 2737 | 3351 |

Step 6. Paint/Steel Type

SS smooth paint on smooth steel +\$0
TS smooth paint on textured steel +\$35
XS textured paint on smooth steel +\$0

Step 7. Surface Finish

Nonmetallic Paint

For smooth paint on smooth steel (SS) or smooth paint on textured steel (TS)

| | | |
|-----------|--|------|
| 8Q | folkstone grey | +\$0 |
| 91 | white | +\$0 |
| 98 | studio white A | +\$0 |
| 9J | sparrow | +\$0 |
| BU | black umber | +\$0 |
| G2 | graphite satin | +\$0 |
| HF | inner tone light | +\$0 |
| HT | inner tone | +\$0 |
| LT | light tone | +\$0 |
| LU | soft white | +\$0 |
| MT | medium tone | +\$0 |
| SG | slate grey | +\$0 |
| WA | wheat | +\$0 |
| WL | sandstone | +\$0 |

Metallic Paint

For smooth paint on smooth steel (SS) or smooth paint on textured steel (TS)

| | | |
|-------------|--------------------|-------|
| 1209 | platinum | +\$65 |
| 1210 | hematite | +\$65 |
| 1212 | bronzite | +\$65 |
| CN | metallic champagne | +\$65 |
| EH | metallic bronze | +\$65 |
| MS | metallic silver | +\$65 |

Sand Texture Paint

For textured paint on smooth steel (XS)

| | | |
|-----------|--|------|
| 98 | studio white A | +\$0 |
|-----------|--|------|

Bright Sand Texture Paint

For textured paint on smooth steel (XS)

| | | |
|-----------|-------------------|------|
| 91 | white | +\$0 |
| CL | cool grey neutral | +\$0 |
| G1 | graphite | +\$0 |
| WN | warm grey neutral | +\$0 |

Bar-Pull Freestanding Lateral File

continued

Step 8. Top

For painted metal front (P-)

| | | |
|------------|---|--------|
| NT | no top | +\$0 |
| T1 | 1"-high painted metal top with squared edge | +\$0 |
| T2 | 1 1/4"-high painted metal top with squared edge | +\$0 |
| T3 | 1 1/4"-high painted metal top with radius edge | +\$63 |
| TL | 1 1/4"-high laminate top with vinyl edge | +\$72 |
| TR | 1 1/4"-high recut veneer top A | +\$147 |
| TF | 1 1/4"-high wood veneer top A | +\$152 |
| T7 | 6 1/2"-high planter top | +\$196 |
| D1 | 6 1/2"-high full dome, side-to-side | +\$267 |
| H1 | 6 1/2"-high half dome, sloping left | +\$267 |
| H2 | 6 1/2"-high half dome, sloping right | +\$267 |
| TV1 | 1 1/8"-high wood veneer top and wood composite edge with oversail front A | +\$314 |
| TC1 | 1" cushion top | +\$386 |
| TC2 | 2" cushion top | +\$386 |

For veneer front (V-)

| | | |
|------------|---|--------|
| NT | no top | +\$0 |
| T1 | 1"-high painted metal top with squared edge | +\$0 |
| T2 | 1 1/4"-high painted metal top with squared edge | +\$0 |
| T3 | 1 1/4"-high painted metal top with radius edge | +\$63 |
| TL | 1 1/4"-high laminate top with vinyl edge | +\$72 |
| TF | 1 1/4"-high wood veneer top A | +\$152 |
| T7 | 6 1/2"-high planter top | +\$196 |
| D1 | 6 1/2"-high full dome, side-to-side | +\$267 |
| H1 | 6 1/2"-high half dome, sloping left | +\$267 |
| H2 | 6 1/2"-high half dome, sloping right | +\$267 |
| TV1 | 1 1/8"-high wood veneer top and wood composite edge with oversail front A | +\$314 |
| TC1 | 1" cushion top | +\$386 |
| TC2 | 2" cushion top | +\$386 |

Step 9.

Veneer Top Finish: Wood Veneer

For painted metal front (P-) with 1 1/4"-high wood veneer top (TF)

| | | |
|-----------|--|-------|
| 2U | light brown walnut A | +\$28 |
| 40 | dark brown walnut A | +\$28 |
| ED | aged cherry A | +\$28 |
| EK | medium red walnut A | +\$28 |
| ET | clear on ash A | +\$28 |
| EV | walnut on ash A | +\$28 |
| UL | natural maple A | +\$28 |
| UX | walnut on cherry A | +\$28 |

Veneer Front Finish: Wood Veneer

For veneer front (V-) with no top (NT), 1"-high painted metal top with squared edge (T1), 1 1/4"-high painted metal top with squared edge (T2), 1 1/4"-high painted metal top with radius edge (T3), 1 1/4"-high laminate top with vinyl edge (TL), 6 1/2"-high planter top (T7), 6 1/2"-high full dome, side-to-side (D1), 6 1/2"-high half dome, sloping left (H1), 6 1/2"-high half dome, sloping right (H2), or 1" cushion top (TC1), or 2" cushion top (TC2)

| | | |
|-----------|--|-------|
| 2U | light brown walnut A | +\$56 |
| 40 | dark brown walnut A | +\$56 |
| ED | aged cherry A | +\$56 |
| EK | medium red walnut A | +\$56 |
| ET | clear on ash A | +\$56 |
| EV | walnut on ash A | +\$56 |
| UL | natural maple A | +\$56 |
| UX | walnut on cherry A | +\$56 |

Veneer Top Finish: Wood Veneer

For painted metal front (P-) with 1 1/8"-high wood veneer top and wood composite edge with oversail front (TV1)

| | | |
|-----------|---|-------|
| 40 | dark brown walnut A | +\$28 |
| ED | aged cherry A | +\$28 |
| EK | medium red walnut A | +\$28 |
| ET | clear on ash A | +\$28 |
| EV | walnut on ash A | +\$28 |
| UL | natural maple A | +\$28 |
| UX | walnut on cherry A | +\$28 |

Veneer Front/Top Finish: Wood Veneer

For veneer front (V-) with 1 1/8"-high wood veneer top and wood composite edge with oversail front (TV1)

| | | |
|-----------|---|-------|
| 40 | dark brown walnut A | +\$56 |
| ED | aged cherry A | +\$56 |
| EK | medium red walnut A | +\$56 |
| ET | clear on ash A | +\$56 |
| EV | walnut on ash A | +\$56 |
| UL | natural maple A | +\$56 |
| UX | walnut on cherry A | +\$56 |

Veneer Top Finish: Recut Veneer

For painted metal front (P-) with 1 1/4"-high recut veneer top (TR)

| | | |
|-----------|---|------|
| RA | light ash A | +\$0 |
| RK | mahogany dark A | +\$0 |
| RM | mahogany A | +\$0 |

Bar-Pull Freestanding Lateral File

continued

| Veneer Front/Top Finish: Wood Veneer | | |
|--|---|-------|
| <i>For veneer front (V-) with 1 1/4"-high wood veneer top (TF)</i> | | |
| 2U | light brown walnut <input type="checkbox"/> A | +\$56 |
| 40 | dark brown walnut <input type="checkbox"/> A | +\$56 |
| ED | aged cherry <input type="checkbox"/> A | +\$56 |
| EK | medium red walnut <input type="checkbox"/> A | +\$56 |
| ET | clear on ash <input type="checkbox"/> A | +\$56 |
| EV | walnut on ash <input type="checkbox"/> A | +\$56 |
| UL | natural maple <input type="checkbox"/> A | +\$56 |
| UX | walnut on cherry <input type="checkbox"/> A | +\$56 |

| Step 10. Top Finish | | |
|--|--|--|
| <i>For 1 1/4"-high laminate top with vinyl edge (TL)</i> | | |

| Solid-Color Laminate | | |
|----------------------|-------------------|------|
| 8Q | folkstone grey | +\$0 |
| 91 | white | +\$0 |
| 98 | studio white | +\$0 |
| CL | cool grey neutral | +\$0 |
| HF | inner tone light | +\$0 |
| HT | inner tone | +\$0 |
| LT | light tone | +\$0 |
| LU | soft white | +\$0 |
| WL | sandstone | +\$0 |
| WN | warm grey neutral | +\$0 |

| Linen Laminate | | |
|----------------|---------------|------|
| LBM | crisp linen | +\$0 |
| LBN | classic linen | +\$0 |
| LBP | casual linen | +\$0 |

| Mesh Laminate | | |
|---------------|-------------|------|
| LBK | pewter mesh | +\$0 |
| LBL | steel mesh | +\$0 |

| Twill Laminate | | |
|----------------|----------------|------|
| LBF | neutral twill | +\$0 |
| LBG | sarum twill | +\$0 |
| LBH | earthen twill | +\$0 |
| LBJ | graphite twill | +\$0 |
| LBQ | white twill | +\$0 |

| Wood-Grain Laminate | | |
|---------------------|--------------------|------|
| HM | natural maple | +\$0 |
| HP | light anigre | +\$0 |
| LA | light ash | +\$0 |
| LBA | clear on ash | +\$0 |
| LBB | oak on ash | +\$0 |
| LBC | walnut on ash | +\$0 |
| LBD | dark brown walnut | +\$0 |
| LBE | medium red walnut | +\$0 |
| LM | mahogany | +\$0 |
| 76 | light brown walnut | +\$0 |
| HX | aged cherry | +\$0 |
| HY | walnut on cherry | +\$0 |

| Zephyr Laminate | | |
|-----------------|--------|------|
| 28 | canyon | +\$0 |
| 29 | misted | +\$0 |

| Step 11. Edge Finish | | |
|--|--------------------|------|
| <i>For 1 1/4"-high laminate top with vinyl edge (TL)</i> | | |
| 28 | canyon | +\$0 |
| 29 | misted | +\$0 |
| 76 | light brown walnut | +\$0 |
| 8Q | folkstone grey | +\$0 |
| 91 | white | +\$0 |
| 98 | studio white | +\$0 |
| BU | black umber | +\$0 |
| CL | cool grey neutral | +\$0 |
| G2 | graphite satin | +\$0 |
| HF | inner tone light | +\$0 |
| HM | natural maple | +\$0 |
| HP | light anigre | +\$0 |
| HT | inner tone | +\$0 |
| HX | aged cherry | +\$0 |
| HY | walnut on cherry | +\$0 |
| LA | light ash | +\$0 |
| LBA | clear on ash | +\$0 |
| LBB | oak on ash | +\$0 |
| LBC | walnut on ash | +\$0 |
| LBD | dark brown walnut | +\$0 |
| LBE | medium red walnut | +\$0 |
| LBK | pewter mesh | +\$0 |
| LBL | steel mesh | +\$0 |
| LBM | crisp linen | +\$0 |
| LBN | classic linen | +\$0 |
| LBP | casual linen | +\$0 |
| LBF | neutral twill | +\$0 |

Meridian® Freestanding Stackable™ Lateral Files

Bar-Pull Freestanding Lateral File

continued

Meridian® Freestanding Stackable™ Lateral Files

| | | |
|------------|-------------------|------|
| LBG | sarum twill | +\$0 |
| LBH | earthen twill | +\$0 |
| LBJ | graphite twill | +\$0 |
| LBQ | white twill | +\$0 |
| LM | mahogany | +\$0 |
| LU | soft white | +\$0 |
| MT | medium tone | +\$0 |
| SG | slate grey | +\$0 |
| WA | wheat | +\$0 |
| WL | sandstone | +\$0 |
| WN | warm grey neutral | +\$0 |

Step 12. Cushion Top Fabric

For 1" cushion top (TC1) or 2" cushion top (TC2)

See textiles list for fabric usage and numbers. First 2 digits of number indicate fabric line; remaining digit(s) indicate fabric color.

| | |
|--|--------|
| Price Category 1 | +\$0 |
| Price Category 2 | +\$68 |
| Price Category 3 | +\$82 |
| Price Category 4 | +\$101 |
| Price Category 7 A | +\$0 |
| Price Category 9 | +\$950 |
| Price Category B | +\$43 |
| Price Category E | +\$90 |
| Price Category F | +\$115 |
| Price Category G | +\$151 |
| Price Category H | +\$185 |
| Price Category I | +\$217 |
| Price Category J | +\$250 |

Step 13. Lock

For no top (NT), 1 1/4"-high laminate top with vinyl edge (TL), 6 1/2"-high planter top (T7), 6 1/2"-high full dome, side-to-side (D1), 6 1/2"-high half dome, sloping left (H1), 6 1/2"-high half dome, sloping right (H2), or 1 1/8"-high wood veneer top and wood composite edge with oversail front (TV1)

| | | |
|-----------|---------|-------|
| NL | no lock | -\$30 |
|-----------|---------|-------|

For 1"-high painted metal top with squared edge (T1), 1 1/4"-high painted metal top with squared edge (T2), 1 1/4"-high painted metal top with radius edge (T3), 1 1/4"-high recut veneer top (TR), 1 1/4"-high wood veneer top (TF), 1" cushion top (TC1), or 2" cushion top (TC2)

| | | |
|-----------|---------------------------|------|
| KA | keyed alike | +\$0 |
| KC | keyed differently, chrome | +\$0 |
| KD | keyed differently, black | +\$0 |

Step 14. Pull Finish

| | | |
|------------|--|-------|
| 8Q | folkstone grey | +\$0 |
| 91 | white | +\$0 |
| G1 | graphite A | +\$0 |
| WL | sandstone A | +\$0 |
| CN | metallic champagne A | +\$0 |
| MS | metallic silver | +\$0 |
| 79 | green apple A | +\$10 |
| MY3 | yellow oxide A | +\$10 |
| RO | red A | +\$10 |
| TRQ | turquoise A | +\$10 |

Step 15. Base Height

| | | |
|------------|---------------------------|-------|
| B1 | 1"-high base | +\$0 |
| B2 | 1 1/2"-high base | +\$0 |
| B3 | 2 1/4"-high base | +\$0 |
| B4 | 3 1/4"-high base | +\$0 |
| BA | 1"-high recessed base | +\$33 |
| BB | 1 1/2"-high recessed base | +\$33 |
| BC | 2 1/4"-high recessed base | +\$33 |
| BD | 3 1/4"-high recessed base | +\$33 |
| B5 | 4 1/4"-high base | +\$33 |
| LB2 | 1 1/2" leg base | +\$33 |

Step 16. Leg

For 1 1/2" leg base (LB2)

| | | |
|-----------|--------------------|--------|
| DD | 2"-high canvas leg | +\$122 |
|-----------|--------------------|--------|

Step 17. Leg Finish

| | | |
|-----------|-------------------|------|
| 91 | white | +\$0 |
| 98 | studio white | +\$0 |
| CL | cool grey neutral | +\$0 |
| G1 | graphite | +\$0 |
| WN | warm grey neutral | +\$0 |

Metallic Paint

| | | |
|-----------|--------------------|-------|
| CN | metallic champagne | +\$10 |
| EH | metallic bronze | +\$10 |
| MS | metallic silver | +\$10 |

Step 18. Counterweight

| | | |
|-----------|--|--------|
| NO | no counterweight (must gang or anchor) | +\$0 |
| CB | counterweight (recommended) | +\$119 |

Bar-Pull Freestanding Lateral File

continued

| | | |
|--------------------------|---------------------------|------|
| Step 19. Drawer Interior | | |
| 9P | front-to-back filing rail | +\$0 |
| 9R | side-to-side filing rail | +\$0 |
| 9M | 3 dividers | +\$0 |

Bevel-Pull Freestanding Lateral File

24-30
24-36
24-42

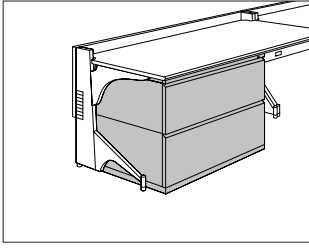

Product Information

Description

This lateral file holds letter-, legal-, and A4-size hanging files. It has bevel pulls and smooth or textured steel. The file has no top or a metal, cushion, laminate, planter, or veneer top. A positive interlock system permits only 1 drawer to open at a time. 1 lock controls all drawers. The drawers can be specified with 3 dividers or with front-to-back or side-to-side filing rails for hanging files. 5 base heights are available; all bases include adjustable glides.

Actual lateral file widths are 29⁷/₈" , 35⁷/₈" , or 41⁷/₈" ; actual depths are 17⁷/₈" or 19⁷/₈" .

Notes

For 2- or 3-high files that are not ganged or anchored, counterweights (option CB) are required. For 4- or 5-high files that are not ganged or anchored, counterweights are recommended.

Dimensional illustrations do not include all possible configurations.

To convert filing direction, order 1 of the following products separately:

- Front-to-back rail (gPxxxx)
- Side-to-side rail (gRxxxx)

See Stackable Lateral File Accessories for specific product number.

Order optional file drawer organizer (LG901) separately.

For work surface on top of 1 or more lateral files, order file top (TPL or TPV) separately.

No lock option (NL) can only be specified on files with no top (NT), dome tops (D1, H1, or H2), planter top (T7), laminate tops (TL), or veneer top (TV1).

For cushion tops TC1 and TC2, a 1" metal top is included.

Cushion top accepts Customer's Own Material (COM). Yardage is estimated for nondirectional, 54"-wide fabrics. When ordering more than 1 cushion, round up total yardage requirement to next whole yard of fabric.

Width—Yardage

30" — 1.05

36" — 1.22

42" — 1.40

For information on multiple quantities or directional fabrics, contact COM Department. See Order Information in Appendices.

For keyed-alike locks, order lock plugs separately. See Keyed-Alike Information in Appendices.

Dimensions

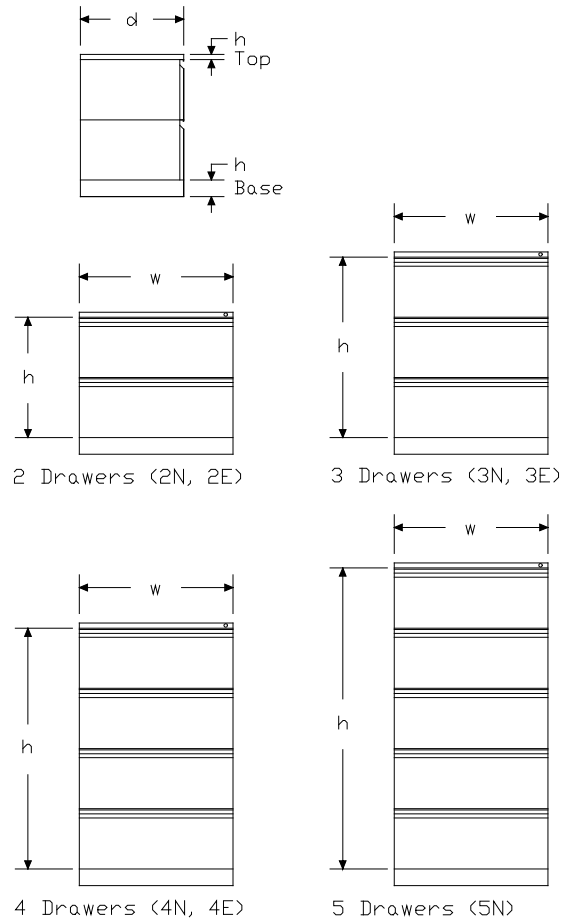

| h | N | E |
|---|--------|--------|
| 2 | 23 1/2 | 26 1/4 |
| 3 | 35 1/4 | 39 3/8 |
| 4 | 47 | 52 1/2 |
| 5 | 58 3/4 | - |

All dimensions are in inches.

Bevel-Pull Freestanding Lateral File *continued*

Specification Information

Step 1.

24-

Step 2. Width

| | |
|-----------|----------|
| 30 | 30" wide |
| 36 | 36" wide |
| 42 | 42" wide |

Step 3. Depth

| | |
|------------|----------|
| 18- | 18" deep |
| 20- | 20" deep |

Step 4. Configuration

| | |
|-----------|---|
| 2N | 2 11 ³ / ₄ "-high drawers |
| 3N | 3 11 ³ / ₄ "-high drawers |
| 4N | 4 11 ³ / ₄ "-high drawers |
| 5N | 5 11 ³ / ₄ "-high drawers |
| 2E | 2 13 ¹ / ₈ "-high drawers |
| 3E | 3 13 ¹ / ₈ "-high drawers |
| 4E | 4 13 ¹ / ₈ "-high drawers |

Prices for Steps 1-4.

| | | 2N | 3N | 4N | 5N | 2E | 3E |
|--------------|------------|-----------|-----------|-----------|-----------|-----------|-----------|
| 24-30 | 18- | \$802 | 1115 | 1430 | 1744 | 802 | 1115 |
| | 20- | \$802 | 1115 | 1430 | 1744 | 802 | 1115 |
| 24-36 | 18- | \$889 | 1232 | 1576 | 1919 | 889 | 1232 |
| | 20- | \$889 | 1232 | 1576 | 1919 | 889 | 1232 |
| 24-42 | 18- | \$1008 | 1394 | 1781 | 2170 | 1008 | 1394 |
| | 20- | \$1008 | 1394 | 1781 | 2170 | 1008 | 1394 |
| | | | | | | | 4E |
| 24-30 | 18- | | | | | | \$1430 |
| | 20- | | | | | | \$1430 |
| 24-36 | 18- | | | | | | \$1576 |
| | 20- | | | | | | \$1576 |
| 24-42 | 18- | | | | | | \$1781 |
| | 20- | | | | | | \$1781 |

Step 5. Paint/Steel Type

| | | |
|-----------|--------------------------------|-------|
| SS | smooth paint on smooth steel | +\$0 |
| TS | smooth paint on textured steel | +\$35 |
| XS | textured paint on smooth steel | +\$0 |

Step 6. Surface Finish

Nonmetallic Paint

For smooth paint on smooth steel (SS) or smooth paint on textured steel (TS)

| | | |
|-----------|--|------|
| 8Q | folkstone grey | +\$0 |
| 91 | white | +\$0 |
| 98 | studio white A | +\$0 |
| 9J | sparrow | +\$0 |
| BU | black umber | +\$0 |
| G2 | graphite satin | +\$0 |
| HF | inner tone light | +\$0 |
| HT | inner tone | +\$0 |
| LT | light tone | +\$0 |
| LU | soft white | +\$0 |
| MT | medium tone | +\$0 |
| SG | slate grey | +\$0 |
| WA | wheat | +\$0 |
| WL | sandstone | +\$0 |

Metallic Paint

For smooth paint on smooth steel (SS) or smooth paint on textured steel (TS)

| | | |
|-------------|--------------------|-------|
| 1209 | platinum | +\$65 |
| 1210 | hematite | +\$65 |
| 1212 | bronzite | +\$65 |
| CN | metallic champagne | +\$65 |
| EH | metallic bronze | +\$65 |
| MS | metallic silver | +\$65 |

Sand Texture Paint

For textured paint on smooth steel (XS)

| | | |
|-----------|--------------|------|
| 98 | studio white | +\$0 |
|-----------|--------------|------|

Bright Sand Texture Paint

For textured paint on smooth steel (XS)

| | | |
|-----------|-------------------|------|
| 91 | white | +\$0 |
| CL | cool grey neutral | +\$0 |
| G1 | graphite | +\$0 |
| WN | warm grey neutral | +\$0 |

Bevel-Pull Freestanding Lateral

File *continued*

| Step 7. Top | | |
|-------------|--|--------|
| NT | no top | +\$0 |
| T1 | 1"-high painted metal top with squared edge | +\$0 |
| T2 | 1¼"-high painted metal top with squared edge | +\$0 |
| T3 | 1¼"-high painted metal top with radius edge | +\$63 |
| TL | 1¼"-high laminate top with vinyl edge | +\$72 |
| TR | 1¼"-high recut veneer top A | +\$147 |
| TF | 1¼"-high wood veneer top A | +\$152 |
| T7 | 6½"-high planter top | +\$196 |
| D1 | 6½"-high full dome, side-to-side | +\$267 |
| H1 | 6½"-high half dome, sloping left | +\$267 |
| H2 | 6½"-high half dome, sloping right | +\$267 |
| TV1 | 1⅛"-high wood veneer top and wood composite edge with oversail front A | +\$314 |
| TC1 | 1" cushion top | +\$386 |
| TC2 | 2" cushion top | +\$386 |

| Step 8. Lock | | |
|--|---------|-------|
| <i>For no top (NT), 1¼"-high laminate top with vinyl edge (TL), 6½"-high planter top (T7), 6½"-high full dome, side-to-side (D1), 6½"-high half dome, sloping left (H1), 6½"-high half dome, sloping right (H2), or 1⅛"-high wood veneer top and wood composite edge with oversail front (TV1)</i> | | |
| NL | no lock | -\$30 |

| | | |
|--|---------------------------|------|
| <i>For 1"-high painted metal top with squared edge (T1), 1¼"-high painted metal top with squared edge (T2), 1¼"-high painted metal top with radius edge (T3), 1¼"-high recut veneer top (TR), 1¼"-high wood veneer top (TF), 1" cushion top (TC1), or 2" cushion top (TC2)</i> | | |
| KA | keyed alike | +\$0 |
| KC | keyed differently, chrome | +\$0 |
| KD | keyed differently, black | +\$0 |

| Step 9. | | |
|--|--|-------|
| Veneer Top Finish: Wood Veneer | | |
| <i>For 1¼"-high wood veneer top (TF)</i> | | |
| 2U | light brown walnut A | +\$28 |
| 40 | dark brown walnut A | +\$28 |
| ED | aged cherry A | +\$28 |
| EK | medium red walnut A | +\$28 |
| ET | clear on ash A | +\$28 |
| EU | oak on ash A | +\$28 |
| EV | walnut on ash A | +\$28 |
| UL | natural maple A | +\$28 |
| UX | walnut on cherry A | +\$28 |

| | | |
|---|---|-------|
| Veneer Top Finish: Wood Veneer | | |
| <i>For 1⅛"-high wood veneer top and wood composite edge with oversail front (TV1)</i> | | |
| 40 | dark brown walnut A | +\$28 |
| ED | aged cherry A | +\$28 |
| EK | medium red walnut A | +\$28 |
| ET | clear on ash A | +\$28 |
| EU | oak on ash A | +\$28 |
| EV | walnut on ash A | +\$28 |
| UL | natural maple A | +\$28 |
| UX | walnut on cherry A | +\$28 |

| | | |
|---|---|------|
| Veneer Top Finish: Recut Veneer | | |
| <i>For 1¼"-high recut veneer top (TR)</i> | | |
| RA | light ash A | +\$0 |
| RK | mahogany dark A | +\$0 |
| RM | mahogany A | +\$0 |

| | | |
|---|-------------------|------|
| Top Finish: Solid-Color Laminate | | |
| <i>For 1¼"-high laminate top with vinyl edge (TL)</i> | | |
| 8Q | folkstone grey | +\$0 |
| 91 | white | +\$0 |
| 98 | studio white | +\$0 |
| CL | cool grey neutral | +\$0 |
| HF | inner tone light | +\$0 |
| HT | inner tone | +\$0 |
| LT | light tone | +\$0 |
| LU | soft white | +\$0 |
| WL | sandstone | +\$0 |
| WN | warm grey neutral | +\$0 |

| | | |
|---|---------------|------|
| Top Finish: Linen Laminate | | |
| <i>For 1¼"-high laminate top with vinyl edge (TL)</i> | | |
| LBM | crisp linen | +\$0 |
| LBN | classic linen | +\$0 |
| LBP | casual linen | +\$0 |

| | | |
|---|-------------|------|
| Top Finish: Mesh Laminate | | |
| <i>For 1¼"-high laminate top with vinyl edge (TL)</i> | | |
| LBK | pewter mesh | +\$0 |
| LBL | steel mesh | +\$0 |

Bevel-Pull Freestanding Lateral File *continued*

| | | |
|--|----------------|------|
| Top Finish: Twill Laminate | | |
| <i>For 1 1/4"-high laminate top with vinyl edge (TL)</i> | | |
| LBF | neutral twill | +\$0 |
| LBG | sarum twill | +\$0 |
| LBH | earthen twill | +\$0 |
| LBJ | graphite twill | +\$0 |
| LBQ | white twill | +\$0 |

| | | |
|--|--------------------|------|
| Top Finish: Wood-Grain Laminate | | |
| <i>For 1 1/4"-high laminate top with vinyl edge (TL)</i> | | |
| HM | natural maple | +\$0 |
| HP | light anigre | +\$0 |
| LA | light ash | +\$0 |
| LBA | clear on ash | +\$0 |
| LBB | oak on ash | +\$0 |
| LBC | walnut on ash | +\$0 |
| LBD | dark brown walnut | +\$0 |
| LBE | medium red walnut | +\$0 |
| LM | mahogany | +\$0 |
| 76 | light brown walnut | +\$0 |
| HX | aged cherry | +\$0 |
| HY | walnut on cherry | +\$0 |

| | | |
|--|--------|------|
| Top Finish: Zephyr Laminate | | |
| <i>For 1 1/4"-high laminate top with vinyl edge (TL)</i> | | |
| 28 | canyon | +\$0 |
| 29 | misted | +\$0 |

| | | |
|--|--------------------|------|
| Step 10. Edge Finish | | |
| <i>For 1 1/4"-high laminate top with vinyl edge (TL)</i> | | |
| 28 | canyon | +\$0 |
| 29 | misted | +\$0 |
| 76 | light brown walnut | +\$0 |
| 8Q | folkstone grey | +\$0 |
| 91 | white | +\$0 |
| 98 | studio white | +\$0 |
| BU | black umber | +\$0 |
| CL | cool grey neutral | +\$0 |
| G2 | graphite satin | +\$0 |
| HF | inner tone light | +\$0 |
| HM | natural maple | +\$0 |
| HP | light anigre | +\$0 |
| HT | inner tone | +\$0 |
| HX | aged cherry | +\$0 |
| HY | walnut on cherry | +\$0 |
| LA | light ash | +\$0 |
| LBA | clear on ash | +\$0 |

| | | |
|------------|-------------------|------|
| LBB | oak on ash | +\$0 |
| LBC | walnut on ash | +\$0 |
| LBD | dark brown walnut | +\$0 |
| LBE | medium red walnut | +\$0 |
| LBK | pewter mesh | +\$0 |
| LBL | steel mesh | +\$0 |
| LBM | crisp linen | +\$0 |
| LBN | classic linen | +\$0 |
| LBP | casual linen | +\$0 |
| LBF | neutral twill | +\$0 |
| LBG | sarum twill | +\$0 |
| LBH | earthen twill | +\$0 |
| LBJ | graphite twill | +\$0 |
| LBQ | white twill | +\$0 |
| LM | mahogany | +\$0 |
| LU | soft white | +\$0 |
| MT | medium tone | +\$0 |
| SG | slate grey | +\$0 |
| WA | wheat | +\$0 |
| WL | sandstone | +\$0 |
| WN | warm grey neutral | +\$0 |

Step 11. Cushion Top Fabric
For 1" cushion top (TC1) or 2" cushion top (TC2)
 See textiles list for fabric numbers. First 2 digits of number indicate fabric line; remaining digit(s) indicate fabric color.

| | |
|---|---------|
| Price Category 1 | +\$0 |
| Price Category 2 | +\$68 |
| Price Category 3 | +\$82 |
| Price Category 4 | +\$101 |
| Price Category 5 | +\$120 |
| Price Category 7 <input type="checkbox"/> A | +\$137 |
| Price Category 9 | +\$950 |
| Price Category (Geiger) 10 | +\$1050 |
| Price Category B | +\$47 |
| Price Category C | +\$65 |
| Price Category D | +\$82 |
| Price Category E | +\$99 |
| Price Category F | +\$141 |
| Price Category G | +\$166 |
| Price Category H | +\$204 |
| Price Category I | +\$264 |
| Price Category J | +\$276 |
| Price Category K | +\$310 |

Bevel-Pull Freestanding Lateral File *continued*

Meridian® Freestanding Stackable™ Lateral Files

| Step 12. Base Height | | |
|--------------------------|--|--------|
| B1 | 1"-high base | +\$0 |
| B2 | 1½"-high base | +\$0 |
| B3 | 2¼"-high base | +\$0 |
| B4 | 3¼"-high base | +\$0 |
| BA | 1"-high recessed base | +\$33 |
| BB | 1½"-high recessed base | +\$33 |
| BC | 2¼"-high recessed base | +\$33 |
| BD | 3¼"-high recessed base | +\$33 |
| B5 | 4¼"-high base | +\$33 |
| Step 13. Counterweight | | |
| NO | no counterweight (must gang or anchor) | +\$0 |
| CB | counterweight (recommended) | +\$119 |
| Step 14. Drawer Interior | | |
| 9P | front-to-back filing rail | +\$0 |
| 9R | side-to-side filing rail | +\$0 |
| 9M | 3 dividers | +\$0 |

Ellipse-Pull Freestanding Lateral File

2J-30
2J-36
2J-42

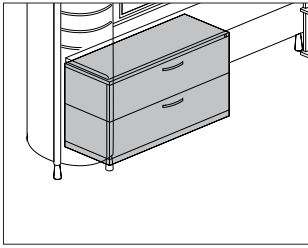

Product Information

Description

This lateral file holds letter-, legal-, and A4-size hanging files. It has ellipse pulls and smooth steel. The file has no top or a metal, cushion, laminate, planter, or veneer top. A positive interlock system permits only 1 drawer to open at a time. 1 lock controls all drawers. The drawers can be specified with 3 dividers or with front-to-back or side-to-side filing rails for hanging files. 5 base heights are available; all bases include adjustable glides.

Actual lateral file widths are 29⁷/₈" , 35⁷/₈" , or 41⁷/₈" ; actual depths are 17⁷/₈" or 19⁷/₈" .

Notes

For 2- or 3-high files that are not ganged or anchored, counterweights (option CB) are required. For 4- or 5-high files that are not ganged or anchored, counterweights are recommended.

Dimensional illustrations do not include all possible configurations.

To convert filing direction, order 1 of the following products separately:

- Front-to-back rail (9Pxxxx)
- Side-to-side rail (9Rxxxx)

See Stackable Lateral File Accessories for specific product number.

Order optional file drawer organizer (LG901) separately.

For work surface on top of 1 or more lateral files, order file top (TPL or TPV) separately.

No lock option (NL) can only be specified on files with no top (NT), dome tops (D1, H1, or H2), planter top (T7), or laminate tops (TL). The (NL) option cannot be specified for configurations 4W and 4Z; these configurations always have a lock.

For configurations 4W and 4Z, a 1" filler top is included between the overhead storage and the drawers.

For cushion tops TC1 and TC2, a 1" metal top is included.

Cushion top accepts Customer's Own Material (COM). Yardage is estimated for nondirectional, 54"-wide fabrics. When ordering more than 1 cushion, round up total yardage requirement to next whole yard of fabric.

Width—Yardage

30" —1.05

36" —1.22

42" —1.40

For information on multiple quantities or directional fabrics, contact COM Department. See Order Information in Appendices.

For keyed-alike locks, order lock plugs separately. See Keyed-Alike Information in Appendices.

Dimensions

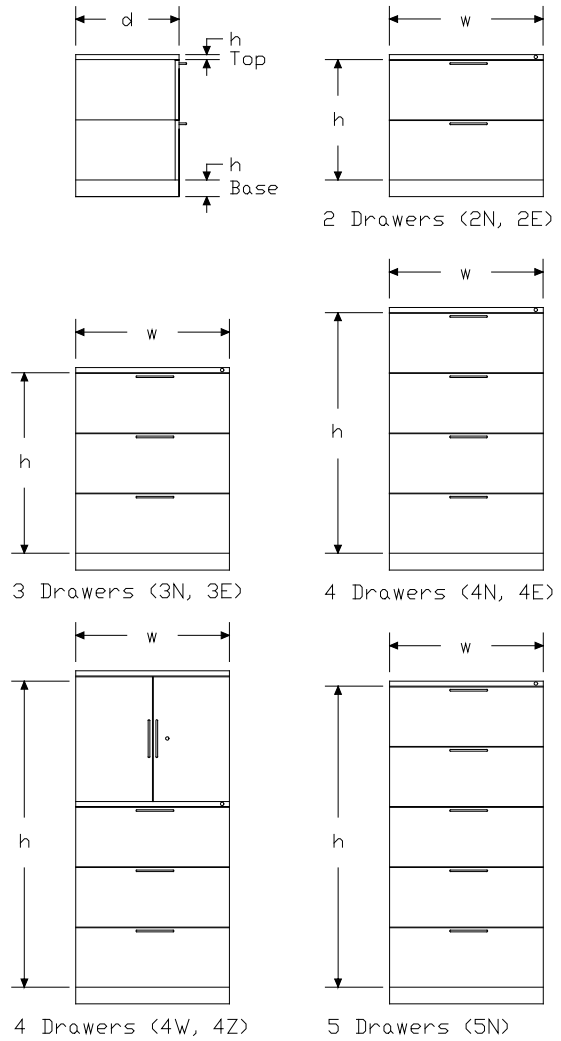

| h | N | E | W | Z |
|---|--------|--------|--------|--------|
| 2 | 23 1/2 | 26 1/4 | - | - |
| 3 | 35 1/4 | 39 3/8 | - | - |
| 4 | 47 | 52 1/2 | 62 1/2 | 66 5/8 |
| 5 | 58 3/4 | - | - | - |

All dimensions are in inches.

Ellipse-Pull Freestanding Lateral

File *continued*

| Specification Information | |
|---------------------------|--|
| Step 1. | |
| 2J- | <input type="checkbox"/> A |
| Step 2. Width | |
| 30 | 30" wide <input type="checkbox"/> A |
| 36 | 36" wide <input type="checkbox"/> A |
| 42 | 42" wide <input type="checkbox"/> A |
| Step 3. Depth | |
| 18- | 18" deep <input type="checkbox"/> A |
| 20- | 20" deep <input type="checkbox"/> A |
| Step 4. Configuration | |
| 2N | 2 11 ³ / ₄ "-high drawers <input type="checkbox"/> A |
| 3N | 3 11 ³ / ₄ "-high drawers <input type="checkbox"/> A |
| 4N | 4 11 ³ / ₄ "-high drawers <input type="checkbox"/> A |
| 4W | 1 26 ¹ / ₄ "-high overhead storage, 3 11 ³ / ₄ "-high drawers <input type="checkbox"/> A |
| 5N | 5 11 ³ / ₄ "-high drawers <input type="checkbox"/> A |
| 2E | 2 13 ¹ / ₈ "-high drawers <input type="checkbox"/> A |
| 3E | 3 13 ¹ / ₈ "-high drawers <input type="checkbox"/> A |
| 4E | 4 13 ¹ / ₈ "-high drawers <input type="checkbox"/> A |
| 4Z | 1 26 ¹ / ₄ "-high overhead storage, 3 13 ¹ / ₈ "-high drawers <input type="checkbox"/> A |

Prices for Steps 1-4.

| | | 2N | 3N | 4N | 4W | 5N | 2E |
|-------|-----|--------|------|--------|------|------|------|
| 2J-30 | 18- | \$878 | 1227 | 1573 | 1941 | 1918 | 878 |
| | 20- | \$878 | 1227 | 1573 | 1941 | 1918 | 878 |
| 2J-36 | 18- | \$978 | 1355 | 1733 | 2166 | 2111 | 978 |
| | 20- | \$978 | 1355 | 1733 | 2166 | 2111 | 978 |
| 2J-42 | 18- | \$1107 | 1532 | 1959 | 2451 | 2388 | 1107 |
| | 20- | \$1107 | 1532 | 1959 | 2451 | 2388 | 1107 |
| | | | | | | | |
| | | | | 3E | 4E | 4Z | |
| 2J-30 | 18- | | | \$1227 | 1573 | 1941 | |
| | 20- | | | \$1227 | 1573 | 1941 | |
| 2J-36 | 18- | | | \$1355 | 1733 | 2166 | |
| | 20- | | | \$1355 | 1733 | 2166 | |
| 2J-42 | 18- | | | \$1532 | 1959 | 2451 | |
| | 20- | | | \$1532 | 1959 | 2451 | |

| Step 5. Paint/Steel Type | | |
|--------------------------|---|-------|
| SS | smooth paint on smooth steel <input type="checkbox"/> A | +\$0 |
| TS | smooth paint on textured steel <input type="checkbox"/> A | +\$35 |
| XS | textured paint on smooth steel <input type="checkbox"/> A | +\$0 |

Step 6. Case Finish

| Nonmetallic Paint | | |
|---|---|------|
| <i>For smooth paint on smooth steel (SS) or smooth paint on textured steel (TS)</i> | | |
| 8Q | folkstone grey <input type="checkbox"/> A | +\$0 |
| 91 | white <input type="checkbox"/> A | +\$0 |
| 98 | studio white <input type="checkbox"/> A | +\$0 |
| 9J | sparrow <input type="checkbox"/> A | +\$0 |
| BU | black umber <input type="checkbox"/> A | +\$0 |
| G2 | graphite satin <input type="checkbox"/> A | +\$0 |
| HF | inner tone light <input type="checkbox"/> A | +\$0 |
| HT | inner tone <input type="checkbox"/> A | +\$0 |
| LT | light tone <input type="checkbox"/> A | +\$0 |
| LU | soft white <input type="checkbox"/> A | +\$0 |
| MT | medium tone <input type="checkbox"/> A | +\$0 |
| SG | slate grey <input type="checkbox"/> A | +\$0 |
| WA | wheat <input type="checkbox"/> A | +\$0 |
| WL | sandstone <input type="checkbox"/> A | +\$0 |

Metallic Paint

| <i>For smooth paint on smooth steel (SS) or smooth paint on textured steel (TS)</i> | | |
|---|---|-------|
| 1209 | platinum <input type="checkbox"/> A | +\$65 |
| 1210 | hematite <input type="checkbox"/> A | +\$65 |
| 1212 | bronzite <input type="checkbox"/> A | +\$65 |
| CN | metallic champagne <input type="checkbox"/> A | +\$65 |
| EH | metallic bronze <input type="checkbox"/> A | +\$65 |
| MS | metallic silver <input type="checkbox"/> A | +\$65 |

Sand Texture Paint

| <i>For textured paint on smooth steel (XS)</i> | | |
|--|---|------|
| 98 | studio white <input type="checkbox"/> A | +\$0 |

Bright Sand Texture Paint

| <i>For textured paint on smooth steel (XS)</i> | | |
|--|--|------|
| 91 | white <input type="checkbox"/> A | +\$0 |
| CL | cool grey neutral <input type="checkbox"/> A | +\$0 |
| G1 | graphite <input type="checkbox"/> A | +\$0 |
| WN | warm grey neutral <input type="checkbox"/> A | +\$0 |

Ellipse-Pull Freestanding Lateral File *continued*

Step 7. Front Finish

Nonmetallic Paint

For smooth paint on smooth steel (SS) or smooth paint on textured steel (TS)

| | | |
|-----------|------------------------------------|------|
| 8Q | folkstone grey A | +\$0 |
| 91 | white A | +\$0 |
| 98 | studio white A | +\$0 |
| 9J | sparrow A | +\$0 |
| BU | black umber A | +\$0 |
| G2 | graphite satin A | +\$0 |
| HF | inner tone light A | +\$0 |
| HT | inner tone A | +\$0 |
| LT | light tone A | +\$0 |
| LU | soft white A | +\$0 |
| MT | medium tone A | +\$0 |
| SG | slate grey A | +\$0 |
| WA | wheat A | +\$0 |
| WL | sandstone A | +\$0 |

Metallic Paint

For smooth paint on smooth steel (SS) or smooth paint on textured steel (TS)

| | | |
|-------------|--------------------------------------|------|
| 1209 | platinum A | +\$0 |
| 1210 | hematite A | +\$0 |
| 1212 | bronzite A | +\$0 |
| CN | metallic champagne A | +\$0 |
| EH | metallic bronze A | +\$0 |
| MS | metallic silver A | +\$0 |

Sand Texture Paint

For textured paint on smooth steel (XS)

| | | |
|-----------|--------------------------------|------|
| 98 | studio white A | +\$0 |
|-----------|--------------------------------|------|

Bright Sand Texture Paint

For textured paint on smooth steel (XS)

| | | |
|-----------|-------------------------------------|------|
| 91 | white A | +\$0 |
| CL | cool grey neutral A | +\$0 |
| G1 | graphite A | +\$0 |
| WN | warm grey neutral A | +\$0 |

Step 8. Top

| | | |
|------------|--|--------|
| NT | no top A | +\$0 |
| T1 | 1"-high painted metal top with squared edge A | +\$0 |
| T2 | 1 ¹ / ₄ "-high painted metal top with squared edge A | +\$0 |
| T3 | 1 ¹ / ₄ "-high painted metal top with radius edge A | +\$63 |
| TL | 1 ¹ / ₄ "-high laminate top with vinyl edge A | +\$72 |
| TR | 1 ¹ / ₄ "-high recut veneer top A | +\$147 |
| TF | 1 ¹ / ₄ "-high wood veneer top A | +\$152 |
| T7 | 6 ¹ / ₂ "-high planter top A | +\$196 |
| D1 | 6 ¹ / ₂ "-high full dome, side-to-side A | +\$267 |
| H1 | 6 ¹ / ₂ "-high half dome, sloping left A | +\$267 |
| H2 | 6 ¹ / ₂ "-high half dome, sloping right A | +\$267 |
| TV1 | 1 ¹ / ₈ "-high wood veneer top and wood composite edge with oversail front A | +\$314 |
| TC1 | 1" cushion top A | +\$386 |
| TC2 | 2" cushion top A | +\$386 |

Step 9. Lock

| | | |
|-----------|---|------|
| KA | keyed alike A | +\$0 |
| KC | keyed differently, chrome A | +\$0 |
| KD | keyed differently, black A | +\$0 |

For 2 11³/₄"-high drawers (2N), 3 11³/₄"-high drawers (3N), 4 11³/₄"-high drawers (4N), 5 11³/₄"-high drawers (5N), 2 13¹/₈"-high drawers (2E), 3 13¹/₈"-high drawers (3E), or 4 13¹/₈"-high drawers (4E) with no top (NT), or 1¹/₄"-high laminate top with vinyl edge (TL), or 6¹/₂"-high planter top (T7), or 6¹/₂"-high full dome, side-to-side (D1), or 6¹/₂"-high half dome, sloping left (H1), or 6¹/₂"-high half dome, sloping right (H2), or 1¹/₈"-high wood veneer top and wood composite edge with oversail front (TV1)

| | | |
|-----------|---------------------------|-------|
| NL | no lock A | -\$30 |
|-----------|---------------------------|-------|

Step 10.

Veneer Top Finish: Wood Veneer

For 1¹/₄"-high wood veneer top (TF)

| | | |
|-----------|--------------------------------------|-------|
| 2U | light brown walnut A | +\$28 |
| 40 | dark brown walnut A | +\$28 |
| ED | aged cherry A | +\$28 |
| EK | medium red walnut A | +\$28 |
| ET | clear on ash A | +\$28 |
| EU | oak on ash A | +\$28 |
| EV | walnut on ash A | +\$28 |
| UL | natural maple A | +\$28 |
| UX | walnut on cherry A | +\$28 |

Ellipse-Pull Freestanding Lateral File *continued*

| | | |
|---|--|------|
| Top Finish: Solid-Color Laminate | | |
| <i>For 1¼"-high laminate top with vinyl edge (TL)</i> | | |
| 8Q | folkstone grey <input type="checkbox"/> | +\$0 |
| 91 | white <input type="checkbox"/> | +\$0 |
| 98 | studio white | +\$0 |
| CL | cool grey neutral <input type="checkbox"/> | +\$0 |
| HF | inner tone light <input type="checkbox"/> | +\$0 |
| HT | inner tone <input type="checkbox"/> | +\$0 |
| LT | light tone <input type="checkbox"/> | +\$0 |
| LU | soft white <input type="checkbox"/> | +\$0 |
| WL | sandstone <input type="checkbox"/> | +\$0 |
| WN | warm grey neutral <input type="checkbox"/> | +\$0 |

| | | |
|---|---------------|------|
| Top Finish: Linen Laminate | | |
| <i>For 1¼"-high laminate top with vinyl edge (TL)</i> | | |
| LBM | crisp linen | +\$0 |
| LBN | classic linen | +\$0 |
| LBP | casual linen | +\$0 |

| | | |
|---|-------------|------|
| Top Finish: Mesh Laminate | | |
| <i>For 1¼"-high laminate top with vinyl edge (TL)</i> | | |
| LBK | pewter mesh | +\$0 |
| LBL | steel mesh | +\$0 |

| | | |
|---|----------------|------|
| Top Finish: Twill Laminate | | |
| <i>For 1¼"-high laminate top with vinyl edge (TL)</i> | | |
| LBF | neutral twill | +\$0 |
| LBG | sarum twill | +\$0 |
| LBH | earthen twill | +\$0 |
| LBJ | graphite twill | +\$0 |
| LBQ | white twill | +\$0 |

| | | |
|---|---|------|
| Top Finish: Wood-Grain Laminate | | |
| <i>For 1¼"-high laminate top with vinyl edge (TL)</i> | | |
| HM | natural maple <input type="checkbox"/> | +\$0 |
| HP | light anigre <input type="checkbox"/> | +\$0 |
| LA | light ash <input type="checkbox"/> | +\$0 |
| LBA | clear on ash | +\$0 |
| LBB | oak on ash | +\$0 |
| LBC | walnut on ash | +\$0 |
| LBD | dark brown walnut | +\$0 |
| LBE | medium red walnut | +\$0 |
| LM | mahogany <input type="checkbox"/> | +\$0 |
| 76 | light brown walnut <input type="checkbox"/> | +\$0 |
| HX | aged cherry <input type="checkbox"/> | +\$0 |
| HY | walnut on cherry <input type="checkbox"/> | +\$0 |

| | | |
|---|---------------------------------|------|
| Top Finish: Zephyr Laminate | | |
| <i>For 1¼"-high laminate top with vinyl edge (TL)</i> | | |
| 28 | canyon <input type="checkbox"/> | +\$0 |
| 29 | misted <input type="checkbox"/> | +\$0 |

| | | |
|---|--|------|
| Veneer Top Finish: Recut Veneer | | |
| <i>For 1¼"-high recut veneer top (TR)</i> | | |
| RA | light ash <input type="checkbox"/> | +\$0 |
| RK | mahogany dark <input type="checkbox"/> | +\$0 |
| RM | mahogany <input type="checkbox"/> | +\$0 |

| | | |
|---|--|-------|
| Veneer Top Finish: Wood Veneer | | |
| <i>For 1⅛"-high wood veneer top and wood composite edge with oversail front (TV1)</i> | | |
| 40 | dark brown walnut <input type="checkbox"/> | +\$28 |
| ED | aged cherry <input type="checkbox"/> | +\$28 |
| EK | medium red walnut <input type="checkbox"/> | +\$28 |
| ET | clear on ash <input type="checkbox"/> | +\$28 |
| EU | oak on ash <input type="checkbox"/> | +\$28 |
| EV | walnut on ash <input type="checkbox"/> | +\$28 |
| UL | natural maple <input type="checkbox"/> | +\$28 |
| UX | walnut on cherry <input type="checkbox"/> | +\$28 |

| | | |
|---|---|------|
| Step 11. Edge Finish | | |
| <i>For 1¼"-high laminate top with vinyl edge (TL)</i> | | |
| 28 | canyon <input type="checkbox"/> | +\$0 |
| 29 | misted <input type="checkbox"/> | +\$0 |
| 76 | light brown walnut <input type="checkbox"/> | +\$0 |
| 8Q | folkstone grey <input type="checkbox"/> | +\$0 |
| 91 | white <input type="checkbox"/> | +\$0 |
| 98 | studio white | +\$0 |
| BU | black umber <input type="checkbox"/> | +\$0 |
| CL | cool grey neutral <input type="checkbox"/> | +\$0 |
| G2 | graphite satin <input type="checkbox"/> | +\$0 |
| HF | inner tone light <input type="checkbox"/> | +\$0 |
| HM | natural maple <input type="checkbox"/> | +\$0 |
| HP | light anigre <input type="checkbox"/> | +\$0 |
| HT | inner tone <input type="checkbox"/> | +\$0 |
| HX | aged cherry <input type="checkbox"/> | +\$0 |
| HY | walnut on cherry <input type="checkbox"/> | +\$0 |
| LA | light ash <input type="checkbox"/> | +\$0 |
| LBA | clear on ash | +\$0 |
| LBB | oak on ash | +\$0 |
| LBC | walnut on ash | +\$0 |
| LBD | dark brown walnut | +\$0 |
| LBE | medium red walnut | +\$0 |
| LBK | pewter mesh | +\$0 |

Ellipse-Pull Freestanding Lateral File *continued*

| | | |
|------------|--|------|
| LBL | steel mesh | +\$0 |
| LBM | crisp linen | +\$0 |
| LBN | classic linen | +\$0 |
| LBP | casual linen | +\$0 |
| LBF | neutral twill | +\$0 |
| LBG | sarum twill | +\$0 |
| LBH | earthen twill | +\$0 |
| LBJ | graphite twill | +\$0 |
| LBQ | white twill | +\$0 |
| LM | mahogany <input type="checkbox"/> | +\$0 |
| LU | soft white <input type="checkbox"/> | +\$0 |
| MT | medium tone <input type="checkbox"/> | +\$0 |
| SG | slate grey <input type="checkbox"/> | +\$0 |
| WA | wheat <input type="checkbox"/> | +\$0 |
| WL | sandstone <input type="checkbox"/> | +\$0 |
| WN | warm grey neutral <input type="checkbox"/> | +\$0 |

Step 12. Cushion Top Fabric

For 1" cushion top (TC1) or 2" cushion top (TC2)

See textiles list for fabric numbers. First 2 digits of number indicate fabric line; remaining digit(s) indicate fabric color.

| | |
|---|---------|
| Price Category 1 | +\$0 |
| Price Category 2 | +\$68 |
| Price Category 3 | +\$82 |
| Price Category 4 | +\$101 |
| Price Category 5 | +\$120 |
| Price Category 7 <input type="checkbox"/> | +\$137 |
| Price Category 9 | +\$950 |
| Price Category (Geiger) 10 | +\$1050 |
| Price Category B | +\$47 |
| Price Category C | +\$65 |
| Price Category D | +\$82 |
| Price Category E | +\$99 |
| Price Category F | +\$141 |
| Price Category G | +\$166 |
| Price Category H | +\$204 |
| Price Category I | +\$211 |
| Price Category J | +\$276 |
| Price Category K | +\$310 |

Step 13. Base Height

| | | |
|-----------|---|-------|
| B1 | 1"-high base <input type="checkbox"/> | +\$0 |
| B2 | 1½"-high base <input type="checkbox"/> | +\$0 |
| B3 | 2¼"-high base <input type="checkbox"/> | +\$0 |
| B4 | 3¼"-high base <input type="checkbox"/> | +\$0 |
| BA | 1"-high recessed base <input type="checkbox"/> | +\$33 |
| BB | 1½"-high recessed base <input type="checkbox"/> | +\$33 |
| BC | 2¼"-high recessed base <input type="checkbox"/> | +\$33 |
| BD | 3¼"-high recessed base <input type="checkbox"/> | +\$33 |
| B5 | 4¼"-high base <input type="checkbox"/> | +\$33 |

Step 14. Counterweight

| | | |
|-----------|---|--------|
| NO | no counterweight (must gang or anchor) <input type="checkbox"/> | +\$0 |
| CB | counterweight (recommended) <input type="checkbox"/> | +\$119 |

Step 15. Drawer Interior

| | | |
|-----------|--|------|
| 9P | front-to-back filing rail <input type="checkbox"/> | +\$0 |
| 9R | side-to-side filing rail <input type="checkbox"/> | +\$0 |
| 9M | 3 dividers <input type="checkbox"/> | +\$0 |

Step 16. Overhead Interior

For 1 26¼"-high overhead storage, 3 11¾"-high drawers (4W) or 1 26¼"-high overhead storage, 3 13⅛"-high drawers (4Z)

| | | |
|------------|---|-------|
| NS0 | no interior option <input type="checkbox"/> | -\$33 |
| NS1 | 1 shelf total <input type="checkbox"/> | +\$0 |
| NS2 | 2 shelves total <input type="checkbox"/> | +\$33 |

Sloped-Pull Freestanding Lateral File

29P-3
29P-4
29V-3
29V-4

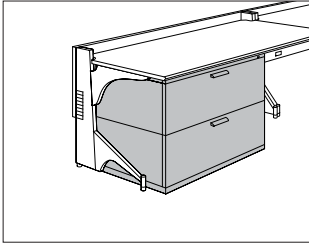

Product Information

Description

This lateral file holds letter-, legal-, and A4-size hanging files. It has sloped pulls and smooth or textured steel. The file has no top or a metal, cushion, laminate, planter, or veneer top. A positive interlock system permits only 1 drawer to open at a time. 1 lock controls all drawers. The drawers can be specified with 3 dividers or with front-to-back or side-to-side filing rails for hanging files. 5 base heights are available; all bases include adjustable glides.

Actual lateral file widths are 29⁷/₈" , 35⁷/₈" , or 41⁷/₈" ; actual depths are 17⁷/₈" or 19⁷/₈" .

Notes

For 2- or 3-high files that are not ganged or anchored, counterweights (option CB) are required. For 4- or 5-high files that are not ganged or anchored, counterweights are recommended.

Dimensional illustrations do not include all possible configurations.

To convert filing direction, order 1 of the following products separately:

- Front-to-back rail (gPxxxx)
- Side-to-side rail (gRxxxx)

See Stackable Lateral File Accessories for specific product number.

Order optional file drawer organizer (LG901) separately.

For work surface on top of 1 or more lateral files, order file top (TPL or TPV) separately.

No lock option (NL) can only be specified on files with no top (NT), dome tops (D1, H1, or H2), planter top (T7), laminate tops (TL), or veneer top (TV1).

For cushion tops TC1 and TC2, a 1" metal top is included.

Grain direction is vertical for veneer-front lateral files.

Cushion top accepts Customer's Own Material (COM). Yardage is estimated for nondirectional, 54"-wide fabrics. When ordering more than 1 cushion, round up total yardage requirement to next whole yard of fabric.

Width—Yardage

30"—1.05

36"—1.22

42"—1.40

For information on multiple quantities or directional fabrics, contact COM Department. See Order Information in Appendices.

For keyed-alike locks, order lock plugs separately. See Keyed-Alike Information in Appendices.

Dimensions

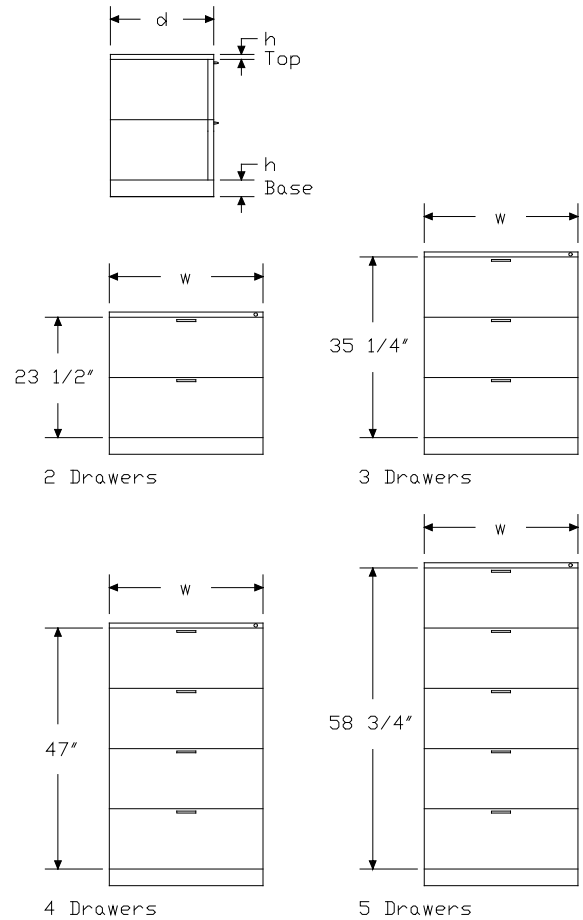

Sloped-Pull Freestanding Lateral File *continued*

Specification Information

Step 1.

29

Step 2. Front Material

- P-** painted metal front
- V-** veneer front A

Step 3. Width

- 30** 30" wide
- 36** 36" wide
- 42** 42" wide

Step 4. Depth

- 18-** 18" deep
- 20-** 20" deep

Step 5. Configuration

- 2N** 2 drawers
- 3N** 3 drawers
- 4N** 4 drawers
- 5N** 5 drawers

Prices for Steps 1-5.

| | | 2N | 3N | 4N | 5N |
|---------------|------------|--------|------|------|------|
| 29P-30 | 18- | \$882 | 1227 | 1573 | 1919 |
| | 20- | \$882 | 1227 | 1573 | 1919 |
| 29P-36 | 18- | \$979 | 1356 | 1734 | 2112 |
| | 20- | \$979 | 1356 | 1734 | 2112 |
| 29P-42 | 18- | \$1109 | 1534 | 1960 | 2387 |
| | 20- | \$1109 | 1534 | 1960 | 2387 |
| 29V-30 | 18- | \$1242 | 1770 | 2294 | 2824 |
| | 20- | \$1242 | 1770 | 2294 | 2824 |
| 29V-36 | 18- | \$1412 | 2006 | 2601 | 3196 |
| | 20- | \$1412 | 2006 | 2601 | 3196 |
| 29V-42 | 18- | \$1609 | 2286 | 2966 | 3642 |
| | 20- | \$1609 | 2286 | 2966 | 3642 |

Step 6. Paint/Steel Type

- SS** smooth paint on smooth steel +\$0
- TS** smooth paint on textured steel +\$35
- XS** textured paint on smooth steel +\$0

Step 7. Surface Finish

Nonmetallic Paint

For smooth paint on smooth steel (SS) or smooth paint on textured steel (TS)

| | | |
|-----------|--|------|
| 8Q | folkstone grey | +\$0 |
| 91 | white | +\$0 |
| 98 | studio white A | +\$0 |
| 9J | sparrow | +\$0 |
| BU | black umber | +\$0 |
| G2 | graphite satin | +\$0 |
| HF | inner tone light | +\$0 |
| HT | inner tone | +\$0 |
| LT | light tone | +\$0 |
| LU | soft white | +\$0 |
| MT | medium tone | +\$0 |
| SG | slate grey | +\$0 |
| WA | wheat | +\$0 |
| WL | sandstone | +\$0 |

Metallic Paint

For smooth paint on smooth steel (SS) or smooth paint on textured steel (TS)

| | | |
|-------------|--------------------|-------|
| 1209 | platinum | +\$65 |
| 1210 | hematite | +\$65 |
| 1212 | bronzite | +\$65 |
| CN | metallic champagne | +\$65 |
| EH | metallic bronze | +\$65 |
| MS | metallic silver | +\$65 |

Sand Texture Paint

For textured paint on smooth steel (XS)

| | | |
|-----------|--|------|
| 98 | studio white A | +\$0 |
|-----------|--|------|

Bright Sand Texture Paint

For textured paint on smooth steel (XS)

| | | |
|-----------|-------------------|------|
| 91 | white | +\$0 |
| CL | cool grey neutral | +\$0 |
| G1 | graphite | +\$0 |
| WN | warm grey neutral | +\$0 |

Sloped-Pull Freestanding Lateral

File *continued*

Step 8. Top

For painted metal front (P-)

| | | |
|------------|---|--------|
| NT | no top | +\$0 |
| T1 | 1"-high painted metal top with squared edge | +\$0 |
| T2 | 1 1/4"-high painted metal top with squared edge | +\$0 |
| T3 | 1 1/4"-high painted metal top with radius edge | +\$63 |
| TL | 1 1/4"-high laminate top with vinyl edge | +\$72 |
| TR | 1 1/4"-high recut veneer top A | +\$147 |
| TF | 1 1/4"-high wood veneer top A | +\$152 |
| T7 | 6 1/2"-high planter top | +\$196 |
| D1 | 6 1/2"-high full dome, side-to-side | +\$267 |
| H1 | 6 1/2"-high half dome, sloping left | +\$267 |
| H2 | 6 1/2"-high half dome, sloping right | +\$267 |
| TV1 | 1 1/8"-high wood veneer top and wood composite edge with oversail front A | +\$314 |
| TC1 | 1" cushion top | +\$386 |
| TC2 | 2" cushion top | +\$386 |

For veneer front (V-)

| | | |
|------------|---|--------|
| NT | no top | +\$0 |
| T1 | 1"-high painted metal top with squared edge | +\$0 |
| T2 | 1 1/4"-high painted metal top with squared edge | +\$0 |
| T3 | 1 1/4"-high painted metal top with radius edge | +\$63 |
| TL | 1 1/4"-high laminate top with vinyl edge | +\$72 |
| TF | 1 1/4"-high wood veneer top A | +\$152 |
| T7 | 6 1/2"-high planter top | +\$196 |
| D1 | 6 1/2"-high full dome, side-to-side | +\$267 |
| H1 | 6 1/2"-high half dome, sloping left | +\$267 |
| H2 | 6 1/2"-high half dome, sloping right | +\$267 |
| TV1 | 1 1/8"-high wood veneer top and wood composite edge with oversail front A | +\$314 |
| TC1 | 1" cushion top | +\$386 |
| TC2 | 2" cushion top | +\$386 |

Step 9.

Veneer Front Finish: Wood Veneer

For veneer front (V-) with no top (NT), 1"-high painted metal top with squared edge (T1), 1 1/4"-high painted metal top with squared edge (T2), 1 1/4"-high painted metal top with radius edge (T3), 1 1/4"-high laminate top with vinyl edge (TL), 6 1/2"-high planter top (T7), 6 1/2"-high full dome, side-to-side (D1), 6 1/2"-high half dome, sloping left (H1), 6 1/2"-high half dome, sloping right (H2), or 1" cushion top (TC1), or 2" cushion top (TC2)

| | | |
|-----------|--|-------|
| 2U | light brown walnut A | +\$56 |
| 40 | dark brown walnut A | +\$56 |
| ED | aged cherry A | +\$56 |
| EK | medium red walnut A | +\$56 |
| ET | clear on ash A | +\$56 |
| EU | oak on ash A | +\$56 |
| EV | walnut on ash A | +\$56 |
| UL | natural maple A | +\$56 |
| UX | walnut on cherry A | +\$56 |

Veneer Top Finish: Wood Veneer

For painted metal front (P-) with 1 1/4"-high wood veneer top (TF)

| | | |
|-----------|--|-------|
| 2U | light brown walnut A | +\$28 |
| 40 | dark brown walnut A | +\$28 |
| ED | aged cherry A | +\$28 |
| EK | medium red walnut A | +\$28 |
| ET | clear on ash A | +\$28 |
| EU | oak on ash A | +\$28 |
| EV | walnut on ash A | +\$28 |
| UL | natural maple A | +\$28 |
| UX | walnut on cherry A | +\$28 |

Veneer Front/Top Finish: Wood Veneer

For veneer front (V-) with 1 1/8"-high wood veneer top and wood composite edge with oversail front (TV1)

| | | |
|-----------|---|-------|
| 40 | dark brown walnut A | +\$56 |
| ED | aged cherry A | +\$56 |
| EK | medium red walnut A | +\$56 |
| ET | clear on ash A | +\$56 |
| EU | oak on ash A | +\$56 |
| EV | walnut on ash A | +\$56 |
| UL | natural maple A | +\$56 |
| UX | walnut on cherry A | +\$56 |

Sloped-Pull Freestanding Lateral File *continued*

Veneer Top Finish: Wood Veneer

For painted metal front (P-) with 1¹/₈"-high wood veneer top and wood composite edge with oversail front (TV1)

| | | |
|-----------|----------------------------|-------|
| 40 | dark brown walnut A | +\$28 |
| ED | aged cherry A | +\$28 |
| EK | medium red walnut A | +\$28 |
| ET | clear on ash A | +\$28 |
| EU | oak on ash A | +\$28 |
| EV | walnut on ash A | +\$28 |
| UL | natural maple A | +\$28 |
| UX | walnut on cherry A | +\$28 |

Veneer Top Finish: Recut Veneer

For painted metal front (P-) with 1¹/₄"-high recut veneer top (TR)

| | | |
|-----------|------------------------|------|
| RA | light ash A | +\$0 |
| RK | mahogany dark A | +\$0 |
| RM | mahogany A | +\$0 |

Veneer Front/Top Finish: Wood Veneer

For veneer front (V-) with 1¹/₄"-high wood veneer top (TF)

| | | |
|-----------|-----------------------------|-------|
| 2U | light brown walnut A | +\$56 |
| 40 | dark brown walnut A | +\$56 |
| ED | aged cherry A | +\$56 |
| EK | medium red walnut A | +\$56 |
| ET | clear on ash A | +\$56 |
| EU | oak on ash A | +\$56 |
| EV | walnut on ash A | +\$56 |
| UL | natural maple A | +\$56 |
| UX | walnut on cherry A | +\$56 |

Step 10. Top Finish

For 1¹/₄"-high laminate top with vinyl edge (TL)

Solid-Color Laminate

| | | |
|-----------|-------------------|------|
| 8Q | folkstone grey | +\$0 |
| 91 | white | +\$0 |
| 98 | studio white | +\$0 |
| CL | cool grey neutral | +\$0 |
| HF | inner tone light | +\$0 |
| HT | inner tone | +\$0 |
| LT | light tone | +\$0 |
| LU | soft white | +\$0 |
| WL | sandstone | +\$0 |
| WN | warm grey neutral | +\$0 |

Linen Laminate

| | | |
|------------|---------------|------|
| LBM | crisp linen | +\$0 |
| LBN | classic linen | +\$0 |
| LBP | casual linen | +\$0 |

Mesh Laminate

| | | |
|------------|-------------|------|
| LBK | pewter mesh | +\$0 |
| LBL | steel mesh | +\$0 |

Twill Laminate

| | | |
|------------|----------------|------|
| LBF | neutral twill | +\$0 |
| LBG | sarum twill | +\$0 |
| LBH | earthen twill | +\$0 |
| LBJ | graphite twill | +\$0 |
| LBQ | white twill | +\$0 |

Wood-Grain Laminate

| | | |
|------------|--------------------|------|
| HM | natural maple | +\$0 |
| HP | light anigre | +\$0 |
| LA | light ash | +\$0 |
| LBA | clear on ash | +\$0 |
| LBB | oak on ash | +\$0 |
| LBC | walnut on ash | +\$0 |
| LBD | dark brown walnut | +\$0 |
| LBE | medium red walnut | +\$0 |
| LM | mahogany | +\$0 |
| 76 | light brown walnut | +\$0 |
| HX | aged cherry | +\$0 |
| HY | walnut on cherry | +\$0 |

Zephyr Laminate

| | | |
|-----------|--------|------|
| 28 | canyon | +\$0 |
| 29 | misted | +\$0 |

Step 11. Edge Finish

For 1¹/₄"-high laminate top with vinyl edge (TL)

| | | |
|-----------|--------------------|------|
| 28 | canyon | +\$0 |
| 29 | misted | +\$0 |
| 76 | light brown walnut | +\$0 |
| 8Q | folkstone grey | +\$0 |
| 91 | white | +\$0 |
| 98 | studio white | +\$0 |
| BU | black umber | +\$0 |
| CL | cool grey neutral | +\$0 |
| G2 | graphite satin | +\$0 |
| HF | inner tone light | +\$0 |
| HM | natural maple | +\$0 |

Sloped-Pull Freestanding Lateral
File *continued*

Meridian® Freestanding Stackable™ Lateral Files

| | | |
|------------|-------------------|------|
| HP | light anigre | +\$0 |
| HT | inner tone | +\$0 |
| HX | aged cherry | +\$0 |
| HY | walnut on cherry | +\$0 |
| LA | light ash | +\$0 |
| LBA | clear on ash | +\$0 |
| LBB | oak on ash | +\$0 |
| LBC | walnut on ash | +\$0 |
| LBD | dark brown walnut | +\$0 |
| LBE | medium red walnut | +\$0 |
| LBK | pewter mesh | +\$0 |
| LBL | steel mesh | +\$0 |
| LBM | crisp linen | +\$0 |
| LBN | classic linen | +\$0 |
| LBP | casual linen | +\$0 |
| LBF | neutral twill | +\$0 |
| LBG | sarum twill | +\$0 |
| LBH | earthen twill | +\$0 |
| LBJ | graphite twill | +\$0 |
| LBQ | white twill | +\$0 |
| LM | mahogany | +\$0 |
| LU | soft white | +\$0 |
| MT | medium tone | +\$0 |
| SG | slate grey | +\$0 |
| WA | wheat | +\$0 |
| WL | sandstone | +\$0 |
| WN | warm grey neutral | +\$0 |

Step 12. Cushion Top Fabric

*For 1" cushion top (TC1) or 2" cushion top (TC2)
See textiles list for fabric numbers. First 2 digits of number indicate fabric line; remaining digit(s) indicate fabric color.*

| | |
|----------------------------|---------|
| Price Category 1 | +\$0 |
| Price Category 2 | +\$68 |
| Price Category 3 | +\$82 |
| Price Category 4 | +\$101 |
| Price Category 5 | +\$120 |
| Price Category 7 A | +\$137 |
| Price Category 9 | +\$950 |
| Price Category (Geiger) 10 | +\$1050 |
| Price Category B | +\$47 |
| Price Category C | +\$65 |
| Price Category D | +\$82 |
| Price Category E | +\$99 |
| Price Category F | +\$141 |
| Price Category G | +\$166 |
| Price Category H | +\$204 |
| Price Category I | +\$264 |
| Price Category J | +\$276 |
| Price Category K | +\$310 |

Step 13. Lock

For no top (NT), 1 1/4"-high laminate top with vinyl edge (TL), 6 1/2"-high planter top (T7), 6 1/2"-high full dome, side-to-side (D1), 6 1/2"-high half dome, sloping left (H1), 6 1/2"-high half dome, sloping right (H2), or 1 1/8"-high wood veneer top and wood composite edge with oversail front (TV1)

| | | |
|-----------|---------|-------|
| NL | no lock | -\$30 |
|-----------|---------|-------|

For 1"-high painted metal top with squared edge (T1), 1 1/4"-high painted metal top with squared edge (T2), 1 1/4"-high painted metal top with radius edge (T3), 1 1/4"-high recut veneer top (TR), 1 1/4"-high wood veneer top (TF), 1" cushion top (TC1), or 2" cushion top (TC2)

| | | |
|-----------|---------------------------|------|
| KA | keyed alike | +\$0 |
| KC | keyed differently, chrome | +\$0 |
| KD | keyed differently, black | +\$0 |

Step 14. Pull Finish

| | | |
|-----------|------------------|------|
| G2 | graphite satin | +\$0 |
| U1 | brushed aluminum | +\$0 |

Sloped-Pull Freestanding Lateral File *continued*

| Step 15. Base Height | | |
|--------------------------|--|--------|
| B1 | 1"-high base | +\$0 |
| B2 | 1½"-high base | +\$0 |
| B3 | 2¼"-high base | +\$0 |
| B4 | 3¼"-high base | +\$0 |
| BA | 1"-high recessed base | +\$33 |
| BB | 1½"-high recessed base | +\$33 |
| BC | 2¼"-high recessed base | +\$33 |
| BD | 3¼"-high recessed base | +\$33 |
| B5 | 4¼"-high base | +\$33 |
| Step 16. Counterweight | | |
| NO | no counterweight (must gang or anchor) | +\$0 |
| CB | counterweight (recommended) | +\$119 |
| Step 17. Drawer Interior | | |
| 9P | front-to-back filing rail | +\$0 |
| 9R | side-to-side filing rail | +\$0 |
| 9M | 3 dividers | +\$0 |

Retrofit Cushion Top

TC1-3

TC1-4

TC2-3

TC2-4

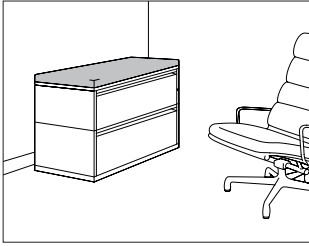

Product Information

Description

This cushion top is retrofit to a lateral file or storage case with a flat metal top. It is available in 2 heights, 3 widths, and 2 depths. Hook-and-loop fastener strips are included to attach cushion to flat metal top.

Notes

Cushion top accepts Customer's Own Material (COM). Yardage is estimated for nondirectional, 54"-wide fabrics. When ordering more than 1 cushion, round up total yardage requirement to next whole yard of fabric.

Width—Yardage

30"—1.05

36"—1.22

42"—1.40

For information on multiple quantities or directional fabrics, contact COM Department. See Order Information in Appendices.

Dimensions

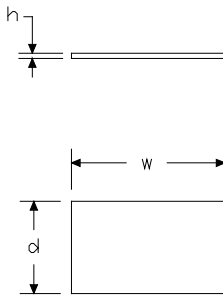

Specification Information

Step 1.

TC

Step 2. Height

1- 1" high

2- 2" high

Step 3. Width

30 30" wide

36 36" wide

42 42" wide

Step 4. Depth

18 18" deep

20 20" deep

Prices for Steps 1-4.

| | | |
|--------|----|-------|
| TC1-30 | 18 | \$375 |
| | 20 | \$375 |
| TC1-36 | 18 | \$375 |
| | 20 | \$375 |
| TC1-42 | 18 | \$375 |
| | 20 | \$375 |
| TC2-30 | 18 | \$375 |
| | 20 | \$375 |
| TC2-36 | 18 | \$375 |
| | 20 | \$375 |
| TC2-42 | 18 | \$375 |
| | 20 | \$375 |

Retrofit Cushion Top *continued*

Step 5. Cushion Top Fabric

See textiles list for fabric numbers. First 2 digits of number indicate fabric line; remaining digit(s) indicate fabric color.

| | |
|--|---------|
| Price Category 1 | +\$0 |
| Price Category 2 | +\$68 |
| Price Category 3 | +\$82 |
| Price Category 4 | +\$101 |
| Price Category 5 | +\$120 |
| Price Category 7 A | +\$137 |
| Price Category 9 | +\$950 |
| Price Category (Geiger) 10 | +\$1050 |
| Price Category B | +\$47 |
| Price Category C | +\$43 |
| Price Category D | +\$82 |
| Price Category E | +\$99 |
| Price Category F | +\$54 |
| Price Category G | +\$166 |
| Price Category H | +\$204 |
| Price Category I | +\$100 |
| Price Category J | +\$276 |
| Price Category K | +\$310 |

Standard-Pull Mobile Lateral File

M26-3
M26-4

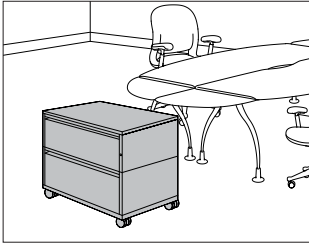

Meridian® Mobile Stackable™ Lateral Files

Product Information

Description

This lateral file holds letter-, legal-, and A4-size hanging files. It has standard pulls and smooth or textured steel. The file has a metal, cushion, laminate, planter, or veneer top. A positive interlock system permits only 1 drawer to open at a time. 1 lock controls all drawers. The drawers can be specified with 3 dividers or with front-to-back or side-to-side filing rails for hanging files. The 4^{3/4}"-high mobile base has a 1^{1/2}"-high base frame with 3^{1/4}"-high outset casters. The 2 swivel and 2 fixed casters must be field installed.

Actual lateral file widths are 29^{7/8}", 35^{7/8}", or 41^{7/8}"; actual depths are 17^{7/8}" or 19^{7/8}".

Notes

Dimensional illustrations do not include all possible configurations.

To convert filing direction, order 1 of the following products separately:

- Front-to-back rail (gPxxxx)
- Side-to-side rail (gRxxxx)

See Stackable Lateral File Accessories for specific product number.

Order optional file drawer organizer (LG901) separately.

For cushion tops TC1 and TC2, a 1" metal top is included.

Cushion top accepts Customer's Own Material (COM). Yardage is estimated for nondirectional, 54"-wide fabrics. When ordering more than 1 cushion, round up total yardage requirement to next whole yard of fabric.

Width—Yardage

30"—1.05

36"—1.22

42"—1.40

For information on multiple quantities or directional fabrics, contact COM Department. See Order Information in Appendices.

For keyed-alike locks, order lock plugs separately. See Keyed-Alike Information in Appendices.

Dimensions

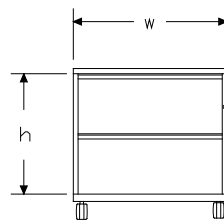
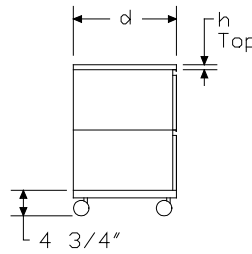

2 Drawers (2N, 2E)

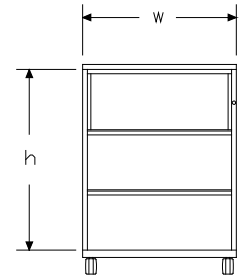

2 Drawers and Pass Through (KNN, KEE)

| h | N | E | NN | EE |
|---|--------|--------|--------|--------|
| 2 | 23 1/2 | 26 1/4 | - | - |
| K | - | - | 36 5/8 | 39 3/8 |

All dimensions are in inches.

Standard-Pull Mobile Lateral File

continued

Specification Information

Step 1.

M26-

Step 2. Width

| | |
|-----------|----------|
| 30 | 30" wide |
| 36 | 36" wide |
| 42 | 42" wide |

Step 3. Depth

| | |
|------------|----------|
| 18- | 18" deep |
| 20- | 20" deep |

Step 4. Configuration

| | |
|------------|--|
| 2N | 2 11 ³ / ₄ "-high drawers |
| 2E | 2 13 ¹ / ₈ "-high drawers |
| KNN | pass-through unit, 2 11 ³ / ₄ "-high drawers |
| KEE | pass-through unit, 2 13 ¹ / ₈ "-high drawers |

Prices for Steps 1-4.

| | 2N | 2E | KNN | KEE |
|-------------------|-----------|-----------|------------|------------|
| M26-30 18- | \$1150 | 1150 | 1479 | 1479 |
| 20- | \$1150 | 1150 | 1479 | 1479 |
| M26-36 18- | \$1251 | 1251 | 1603 | 1603 |
| 20- | \$1251 | 1251 | 1603 | 1603 |
| M26-42 18- | \$1376 | 1376 | 1774 | 1774 |
| 20- | \$1376 | 1376 | 1774 | 1774 |

Step 5. Paint/Steel Type

| | | |
|-----------|--------------------------------|-------|
| SS | smooth paint on smooth steel | +\$0 |
| TS | smooth paint on textured steel | +\$35 |
| XS | textured paint on smooth steel | +\$0 |

Step 6. Surface Finish

Nonmetallic Paint

For smooth paint on smooth steel (SS) or smooth paint on textured steel (TS)

| | | |
|-----------|-----------------------|------|
| 8Q | folkstone grey | +\$0 |
| 91 | white | +\$0 |
| 98 | studio white A | +\$0 |
| 9J | sparrow | +\$0 |
| BU | black umber | +\$0 |
| G2 | graphite satin | +\$0 |
| HF | inner tone light | +\$0 |
| HT | inner tone | +\$0 |
| LT | light tone | +\$0 |
| LU | soft white | +\$0 |
| MT | medium tone | +\$0 |
| SG | slate grey | +\$0 |
| WA | wheat | +\$0 |
| WL | sandstone | +\$0 |

Metallic Paint

For smooth paint on smooth steel (SS) or smooth paint on textured steel (TS)

| | | |
|-------------|--------------------|-------|
| 1209 | platinum | +\$65 |
| 1210 | hematite | +\$65 |
| 1212 | bronzite | +\$65 |
| CN | metallic champagne | +\$65 |
| EH | metallic bronze | +\$65 |
| MS | metallic silver | +\$65 |

Sand Texture Paint

For textured paint on smooth steel (XS)

| | | |
|-----------|-----------------------|------|
| 98 | studio white A | +\$0 |
|-----------|-----------------------|------|

Bright Sand Texture Paint

For textured paint on smooth steel (XS)

| | | |
|-----------|-------------------|------|
| 91 | white | +\$0 |
| CL | cool grey neutral | +\$0 |
| G1 | graphite | +\$0 |
| WN | warm grey neutral | +\$0 |

Meridian® Mobile Stackable™ Lateral Files

Standard-Pull Mobile Lateral File

continued

Meridian® Mobile Stackable™ Lateral Files

| Step 7. Top | | |
|-------------|---|--------|
| T1 | 1"-high painted metal top with squared edge | +\$0 |
| T2 | 1¼"-high painted metal top with squared edge | +\$0 |
| T3 | 1¼"-high painted metal top with radius edge | +\$63 |
| TL | 1¼"-high laminate top with vinyl edge | +\$72 |
| TR | 1¼"-high recut veneer top <input type="checkbox"/> A | +\$147 |
| TF | 1¼"-high wood veneer top <input type="checkbox"/> A | +\$152 |
| T7 | 6½"-high planter top | +\$196 |
| D1 | 6½"-high full dome, side-to-side | +\$267 |
| H1 | 6½"-high half dome, sloping left | +\$267 |
| H2 | 6½"-high half dome, sloping right | +\$267 |
| TV1 | 1⅛"-high wood veneer top and wood composite edge with oversail front <input type="checkbox"/> A | +\$314 |
| TC1 | 1" cushion top | +\$386 |
| TC2 | 2" cushion top | +\$386 |

Step 8.

| Veneer Top Finish | | |
|--|---|-------|
| <i>For 1¼"-high wood veneer top (TF)</i> | | |
| 2U | light brown walnut <input type="checkbox"/> A | +\$28 |
| 40 | dark brown walnut <input type="checkbox"/> A | +\$28 |
| ED | aged cherry <input type="checkbox"/> A | +\$28 |
| EK | medium red walnut <input type="checkbox"/> A | +\$28 |
| ET | clear on ash <input type="checkbox"/> A | +\$28 |
| EU | oak on ash <input type="checkbox"/> A | +\$28 |
| EV | walnut on ash <input type="checkbox"/> A | +\$28 |
| UL | natural maple <input type="checkbox"/> A | +\$28 |
| UX | walnut on cherry <input type="checkbox"/> A | +\$28 |

| Veneer Top Finish | | |
|---|--|------|
| <i>For 1¼"-high recut veneer top (TR)</i> | | |
| RA | light ash <input type="checkbox"/> A | +\$0 |
| RK | mahogany dark <input type="checkbox"/> A | +\$0 |
| RM | mahogany <input type="checkbox"/> A | +\$0 |

| Top Finish: Solid-Color Laminate | | |
|---|-------------------|------|
| <i>For 1¼"-high laminate top with vinyl edge (TL)</i> | | |
| 8Q | folkstone grey | +\$0 |
| 91 | white | +\$0 |
| 98 | studio white | +\$0 |
| CL | cool grey neutral | +\$0 |
| HF | inner tone light | +\$0 |
| HT | inner tone | +\$0 |
| LT | light tone | +\$0 |
| LU | soft white | +\$0 |
| WL | sandstone | +\$0 |
| WN | warm grey neutral | +\$0 |

| Top Finish: Linen Laminate | | |
|---|---------------|------|
| <i>For 1¼"-high laminate top with vinyl edge (TL)</i> | | |
| LBM | crisp linen | +\$0 |
| LBN | classic linen | +\$0 |
| LBP | casual linen | +\$0 |

| Top Finish: Mesh Laminate | | |
|---|-------------|------|
| <i>For 1¼"-high laminate top with vinyl edge (TL)</i> | | |
| LBK | pewter mesh | +\$0 |
| LBL | steel mesh | +\$0 |

| Top Finish: Twill Laminate | | |
|---|----------------|------|
| <i>For 1¼"-high laminate top with vinyl edge (TL)</i> | | |
| LBF | neutral twill | +\$0 |
| LBG | sarum twill | +\$0 |
| LBH | earthen twill | +\$0 |
| LBJ | graphite twill | +\$0 |
| LBQ | white twill | +\$0 |

| Top Finish: Wood-Grain Laminate | | |
|---|--------------------|------|
| <i>For 1¼"-high laminate top with vinyl edge (TL)</i> | | |
| HM | natural maple | +\$0 |
| HP | light anigre | +\$0 |
| LA | light ash | +\$0 |
| LBA | clear on ash | +\$0 |
| LBB | oak on ash | +\$0 |
| LBC | walnut on ash | +\$0 |
| LBD | dark brown walnut | +\$0 |
| LBE | medium red walnut | +\$0 |
| LM | mahogany | +\$0 |
| 76 | light brown walnut | +\$0 |
| HX | aged cherry | +\$0 |
| HY | walnut on cherry | +\$0 |

Standard-Pull Mobile Lateral File

continued

| | | |
|--|--------|------|
| Top Finish: Zephyr Laminate | | |
| <i>For 1 1/4"-high laminate top with vinyl edge (TL)</i> | | |
| 28 | canyon | +\$0 |
| 29 | misted | +\$0 |

| | | |
|--|--------------------------------|-------|
| Veneer Top Finish | | |
| <i>For 1 1/8"-high wood veneer top and wood composite edge with oversail front (TV1)</i> | | |
| 40 | dark brown walnut ^A | +\$28 |
| ED | aged cherry ^A | +\$28 |
| EK | medium red walnut ^A | +\$28 |
| ET | clear on ash ^A | +\$28 |
| EU | oak on ash ^A | +\$28 |
| EV | walnut on ash ^A | +\$28 |
| UL | natural maple ^A | +\$28 |
| UX | walnut on cherry ^A | +\$28 |

| | | |
|--|--------------------|------|
| Step 9. Edge Finish | | |
| <i>For 1 1/4"-high laminate top with vinyl edge (TL)</i> | | |
| 28 | canyon | +\$0 |
| 29 | misted | +\$0 |
| 76 | light brown walnut | +\$0 |
| 8Q | folkstone grey | +\$0 |
| 91 | white | +\$0 |
| 98 | studio white | +\$0 |
| BU | black umber | +\$0 |
| CL | cool grey neutral | +\$0 |
| G2 | graphite satin | +\$0 |
| HF | inner tone light | +\$0 |
| HM | natural maple | +\$0 |
| HP | light anigre | +\$0 |
| HT | inner tone | +\$0 |
| HX | aged cherry | +\$0 |
| HY | walnut on cherry | +\$0 |
| LA | light ash | +\$0 |
| LBA | clear on ash | +\$0 |
| LBB | oak on ash | +\$0 |
| LBC | walnut on ash | +\$0 |
| LBD | dark brown walnut | +\$0 |
| LBE | medium red walnut | +\$0 |
| LBK | pewter mesh | +\$0 |
| LBL | steel mesh | +\$0 |
| LBM | crisp linen | +\$0 |
| LBN | classic linen | +\$0 |
| LBP | casual linen | +\$0 |
| LBF | neutral twill | +\$0 |
| LBG | sarum twill | +\$0 |

| | | |
|------------|-------------------|------|
| LBH | earthen twill | +\$0 |
| LBJ | graphite twill | +\$0 |
| LBQ | white twill | +\$0 |
| LM | mahogany | +\$0 |
| LU | soft white | +\$0 |
| MT | medium tone | +\$0 |
| SG | slate grey | +\$0 |
| WA | wheat | +\$0 |
| WL | sandstone | +\$0 |
| WN | warm grey neutral | +\$0 |

Step 10. Cushion Top Fabric
For 1" cushion top (TC1) or 2" cushion top (TC2)
See textiles list for fabric numbers. First 2 digits of number indicate fabric line; remaining digit(s) indicate fabric color.

| | |
|-------------------------------|---------|
| Price Category 1 | +\$0 |
| Price Category 2 | +\$68 |
| Price Category 3 | +\$82 |
| Price Category 4 | +\$101 |
| Price Category 5 | +\$120 |
| Price Category 7 ^A | +\$137 |
| Price Category 9 | +\$950 |
| Price Category (Geiger) 10 | +\$1050 |
| Price Category B | +\$47 |
| Price Category C | +\$65 |
| Price Category D | +\$82 |
| Price Category E | +\$99 |
| Price Category F | +\$141 |
| Price Category G | +\$166 |
| Price Category H | +\$204 |
| Price Category I | +\$264 |
| Price Category J | +\$276 |
| Price Category K | +\$310 |

| | | |
|---------------|---------------------------|------|
| Step 11. Lock | | |
| KA | keyed alike | +\$0 |
| KC | keyed differently, chrome | +\$0 |
| KD | keyed differently, black | +\$0 |

| | | |
|--------------------------|---------------------------|------|
| Step 12. Drawer Interior | | |
| 9M | 3 dividers | +\$0 |
| 9P | front-to-back filing rail | +\$0 |
| 9R | side-to-side filing rail | +\$0 |

Meridian® Mobile Stackable™ Lateral Files

Bevel-Pull Mobile Lateral File

M24-3
M24-4

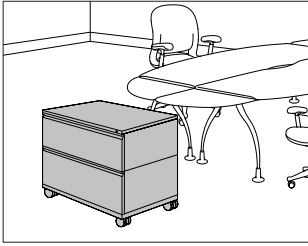

Meridian® Mobile Stackable™ Lateral Files

Product Information

Description

This lateral file holds letter-, legal-, and A4-size hanging files. It has bevel pulls and smooth or textured steel. The file has a metal, cushion, laminate, planter, or veneer top. A positive interlock system permits only 1 drawer to open at a time. 1 lock controls all drawers. The drawers can be specified with 3 dividers or with front-to-back or side-to-side filing rails for hanging files. The 4^{3/4}"-high mobile base has a 1^{1/2}"-high base frame with 3^{1/4}"-high outset casters. The 2 swivel and 2 fixed casters must be field installed.

Actual lateral file widths are 29^{7/8}", 35^{7/8}", or 41^{7/8}"; actual depths are 17^{7/8}" or 19^{7/8}".

Notes

Dimensional illustrations do not include all possible configurations.

To convert filing direction, order 1 of the following products separately:

- Front-to-back rail (gPxxxx)
- Side-to-side rail (gRxxxx)

See Stackable Lateral File Accessories for specific product number.

Order optional file drawer organizer (LG901) separately.

For cushion tops TC1 and TC2, a 1" metal top is included.

Cushion top accepts Customer's Own Material (COM). Yardage is estimated for nondirectional, 54"-wide fabrics. When ordering more than 1 cushion, round up total yardage requirement to next whole yard of fabric.

Width—Yardage

30"—1.05

36"—1.22

42"—1.40

For information on multiple quantities or directional fabrics, contact COM Department. See Order Information in Appendices.

For keyed-alike locks, order lock plugs separately. See Keyed-Alike Information in Appendices.

Dimensions

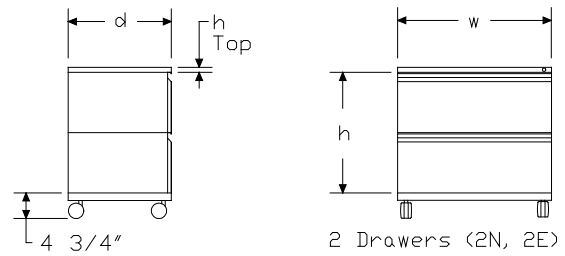

| h | N | E |
|---|--------|--------|
| 2 | 23 1/2 | 26 1/4 |

All dimensions are in inches.

Bevel-Pull Mobile Lateral File

continued

Specification Information

Step 1.

M24-

Step 2. Width

| | |
|-----------|----------|
| 30 | 30" wide |
| 36 | 36" wide |
| 42 | 42" wide |

Step 3. Depth

| | |
|------------|----------|
| 18- | 18" deep |
| 20- | 20" deep |

Step 4. Configuration

| | |
|-----------|---|
| 2N | 2 11 ³ / ₄ "-high drawers |
| 2E | 2 13 ¹ / ₈ "-high drawers |

Prices for Steps 1-4.

| | 2N | 2E |
|-------------------|-----------|-----------|
| M24-30 18- | \$1150 | 1150 |
| 20- | \$1150 | 1150 |
| M24-36 18- | \$1251 | 1251 |
| 20- | \$1251 | 1251 |
| M24-42 18- | \$1376 | 1376 |
| 20- | \$1376 | 1376 |

Step 5. Paint/Steel Type

| | | |
|-----------|--------------------------------|-------|
| SS | smooth paint on smooth steel | +\$0 |
| TS | smooth paint on textured steel | +\$35 |
| XS | textured paint on smooth steel | +\$0 |

Step 6. Surface Finish

Nonmetallic Paint

For smooth paint on smooth steel (SS) or smooth paint on textured steel (TS)

| | | |
|-----------|-----------------------|------|
| 8Q | folkstone grey | +\$0 |
| 91 | white | +\$0 |
| 98 | studio white A | +\$0 |
| 9J | sparrow | +\$0 |
| BU | black umber | +\$0 |
| G2 | graphite satin | +\$0 |
| HF | inner tone light | +\$0 |
| HT | inner tone | +\$0 |
| LT | light tone | +\$0 |
| LU | soft white | +\$0 |
| MT | medium tone | +\$0 |
| SG | slate grey | +\$0 |
| WA | wheat | +\$0 |
| WL | sandstone | +\$0 |

Metallic Paint

For smooth paint on smooth steel (SS) or smooth paint on textured steel (TS)

| | | |
|-------------|--------------------|-------|
| 1209 | platinum | +\$65 |
| 1210 | hematite | +\$65 |
| 1212 | bronzite | +\$65 |
| CN | metallic champagne | +\$65 |
| EH | metallic bronze | +\$65 |
| MS | metallic silver | +\$65 |

Sand Texture Paint

For textured paint on smooth steel (XS)

| | | |
|-----------|-----------------------|------|
| 98 | studio white A | +\$0 |
|-----------|-----------------------|------|

Bright Sand Texture Paint

For textured paint on smooth steel (XS)

| | | |
|-----------|-------------------|------|
| 91 | white | +\$0 |
| CL | cool grey neutral | +\$0 |
| G1 | graphite | +\$0 |
| WN | warm grey neutral | +\$0 |

Meridian® Mobile Stackable™ Lateral Files

Bevel-Pull Mobile Lateral File

continued

Meridian® Mobile Stackable™ Lateral Files

| Step 7. Top | | |
|-------------|---|--------|
| T1 | 1"-high painted metal top with squared edge | +\$0 |
| T2 | 1¼"-high painted metal top with squared edge | +\$0 |
| T3 | 1¼"-high painted metal top with radius edge | +\$63 |
| TL | 1¼"-high laminate top with vinyl edge | +\$72 |
| TR | 1¼"-high recut veneer top <input type="checkbox"/> A | +\$147 |
| TF | 1¼"-high wood veneer top <input type="checkbox"/> A | +\$152 |
| T7 | 6½"-high planter top | +\$196 |
| D1 | 6½"-high full dome, side-to-side | +\$267 |
| H1 | 6½"-high half dome, sloping left | +\$267 |
| H2 | 6½"-high half dome, sloping right | +\$267 |
| TV1 | 1⅛"-high wood veneer top and wood composite edge with oversail front <input type="checkbox"/> A | +\$314 |
| TC1 | 1" cushion top | +\$386 |
| TC2 | 2" cushion top | +\$386 |

| Step 8. Lock | | |
|--|---------------------------|------|
| <i>For 1"-high painted metal top with squared edge (T1), 1¼"-high painted metal top with squared edge (T2), 1¼"-high painted metal top with radius edge (T3), 1¼"-high recut veneer top (TR), 1¼"-high wood veneer top (TF), 1" cushion top (TC1), or 2" cushion top (TC2)</i> | | |
| KA | keyed alike | +\$0 |
| KC | keyed differently, chrome | +\$0 |
| KD | keyed differently, black | +\$0 |

| | | |
|---|---------|-------|
| <i>For 1¼"-high laminate top with vinyl edge (TL), 6½"-high planter top (T7), 6½"-high full dome, side-to-side (D1), 6½"-high half dome, sloping left (H1), 6½"-high half dome, sloping right (H2), or 1⅛"-high wood veneer top and wood composite edge with oversail front (TV1)</i> | | |
| NL | no lock | -\$30 |

| Step 9. | | |
|--|---|-------|
| Veneer Top Finish: Wood Veneer | | |
| <i>For 1¼"-high wood veneer top (TF)</i> | | |
| 2U | light brown walnut <input type="checkbox"/> A | +\$28 |
| 40 | dark brown walnut <input type="checkbox"/> A | +\$28 |
| ED | aged cherry <input type="checkbox"/> A | +\$28 |
| EK | medium red walnut <input type="checkbox"/> A | +\$28 |
| ET | clear on ash <input type="checkbox"/> A | +\$28 |
| EU | oak on ash <input type="checkbox"/> A | +\$28 |
| EV | walnut on ash <input type="checkbox"/> A | +\$28 |
| UL | natural maple <input type="checkbox"/> A | +\$28 |
| UX | walnut on cherry <input type="checkbox"/> A | +\$28 |

| | | |
|---|--|------|
| Veneer Top Finish: Recut Veneer | | |
| <i>For 1¼"-high recut veneer top (TR)</i> | | |
| RA | light ash <input type="checkbox"/> A | +\$0 |
| RK | mahogany dark <input type="checkbox"/> A | +\$0 |
| RM | mahogany <input type="checkbox"/> A | +\$0 |

| | | |
|---|-------------------|------|
| Top Finish: Solid-Color Laminate | | |
| <i>For 1¼"-high laminate top with vinyl edge (TL)</i> | | |
| 8Q | folkstone grey | +\$0 |
| 91 | white | +\$0 |
| 98 | studio white | +\$0 |
| CL | cool grey neutral | +\$0 |
| HF | inner tone light | +\$0 |
| HT | inner tone | +\$0 |
| LT | light tone | +\$0 |
| LU | soft white | +\$0 |
| WL | sandstone | +\$0 |
| WN | warm grey neutral | +\$0 |

| | | |
|---|---------------|------|
| Top Finish: Linen Laminate | | |
| <i>For 1¼"-high laminate top with vinyl edge (TL)</i> | | |
| LBM | crisp linen | +\$0 |
| LBN | classic linen | +\$0 |
| LBP | casual linen | +\$0 |

| | | |
|---|-------------|------|
| Top Finish: Mesh Laminate | | |
| <i>For 1¼"-high laminate top with vinyl edge (TL)</i> | | |
| LBK | pewter mesh | +\$0 |
| LBL | steel mesh | +\$0 |

| | | |
|---|----------------|------|
| Top Finish: Twill Laminate | | |
| <i>For 1¼"-high laminate top with vinyl edge (TL)</i> | | |
| LBF | neutral twill | +\$0 |
| LBG | sarum twill | +\$0 |
| LBH | earthen twill | +\$0 |
| LBJ | graphite twill | +\$0 |
| LBQ | white twill | +\$0 |

Bevel-Pull Mobile Lateral File

continued

Top Finish: Wood-Grain Laminate

For 1 1/4"-high laminate top with vinyl edge (TL)

| | | |
|------------|--------------------|------|
| HM | natural maple | +\$0 |
| HP | light anigre | +\$0 |
| LA | light ash | +\$0 |
| LBA | clear on ash | +\$0 |
| LBB | oak on ash | +\$0 |
| LBC | walnut on ash | +\$0 |
| LBD | dark brown walnut | +\$0 |
| LBE | medium red walnut | +\$0 |
| LM | mahogany | +\$0 |
| 76 | light brown walnut | +\$0 |
| HX | aged cherry | +\$0 |
| HY | walnut on cherry | +\$0 |

Top Finish: Zephyr Laminate

For 1 1/4"-high laminate top with vinyl edge (TL)

| | | |
|-----------|--------|------|
| 28 | canyon | +\$0 |
| 29 | misted | +\$0 |

Veneer Top Finish: Wood Veneer

For 1 1/8"-high wood veneer top and wood composite edge with oversail front (TV1)

| | | |
|-----------|----------------------------|-------|
| 40 | dark brown walnut A | +\$28 |
| ED | aged cherry A | +\$28 |
| EK | medium red walnut A | +\$28 |
| ET | clear on ash A | +\$28 |
| EU | oak on ash A | +\$28 |
| EV | walnut on ash A | +\$28 |
| UL | natural maple A | +\$28 |
| UX | walnut on cherry A | +\$28 |

Step 10. Edge Finish

For 1 1/4"-high laminate top with vinyl edge (TL)

| | | |
|-----------|--------------------|------|
| 28 | canyon | +\$0 |
| 29 | misted | +\$0 |
| 76 | light brown walnut | +\$0 |
| 8Q | folkstone grey | +\$0 |
| 91 | white | +\$0 |
| 98 | studio white | +\$0 |
| BU | black umber | +\$0 |
| CL | cool grey neutral | +\$0 |
| G2 | graphite satin | +\$0 |
| HF | inner tone light | +\$0 |
| HM | natural maple | +\$0 |
| HP | light anigre | +\$0 |
| HT | inner tone | +\$0 |

| | | |
|------------|-------------------|------|
| HX | aged cherry | +\$0 |
| HY | walnut on cherry | +\$0 |
| LA | light ash | +\$0 |
| LBA | clear on ash | +\$0 |
| LBB | oak on ash | +\$0 |
| LBC | walnut on ash | +\$0 |
| LBD | dark brown walnut | +\$0 |
| LBE | medium red walnut | +\$0 |
| LBK | pewter mesh | +\$0 |
| LBL | steel mesh | +\$0 |
| LBM | crisp linen | +\$0 |
| LBN | classic linen | +\$0 |
| LBP | casual linen | +\$0 |
| LBF | neutral twill | +\$0 |
| LBG | sarum twill | +\$0 |
| LBH | earthen twill | +\$0 |
| LBJ | graphite twill | +\$0 |
| LBQ | white twill | +\$0 |
| LM | mahogany | +\$0 |
| LU | soft white | +\$0 |
| MT | medium tone | +\$0 |
| SG | slate grey | +\$0 |
| WA | wheat | +\$0 |
| WL | sandstone | +\$0 |
| WN | warm grey neutral | +\$0 |

Meridian® Mobile Stackable™ Lateral Files

Bevel-Pull Mobile Lateral File

continued

| Step 11. Cushion Top Fabric | | |
|---|--|---------|
| <i>For 1" cushion top (TC1) or 2" cushion top (TC2)</i> | | |
| <i>See textiles list for fabric numbers. First 2 digits of number indicate fabric line; remaining digit(s) indicate fabric color.</i> | | |
| Price Category 1 | | +\$0 |
| Price Category 2 | | +\$68 |
| Price Category 3 | | +\$82 |
| Price Category 4 | | +\$101 |
| Price Category 5 | | +\$120 |
| Price Category 7 A | | +\$137 |
| Price Category 9 | | +\$950 |
| Price Category (Geiger) 10 | | +\$1050 |
| Price Category B | | +\$47 |
| Price Category C | | +\$65 |
| Price Category D | | +\$82 |
| Price Category E | | +\$99 |
| Price Category F | | +\$141 |
| Price Category G | | +\$166 |
| Price Category H | | +\$204 |
| Price Category I | | +\$264 |
| Price Category J | | +\$276 |
| Price Category K | | +\$310 |

| Step 12. Drawer Interior | | |
|--------------------------|---------------------------|------|
| 9M | 3 dividers | +\$0 |
| 9P | front-to-back filing rail | +\$0 |
| 9R | side-to-side filing rail | +\$0 |

Meridian® Low Credenza

C2A-3
C2A-4
C2K-3
C2K-4

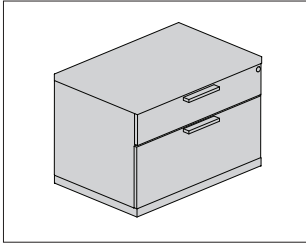

Product Information

Description

This credenza holds letter-, legal-, and A4-size hanging files in the file drawer. The box drawer provides for storage of miscellaneous supplies and personal items.

Actual credenza widths are 29⁷/₈" , 35⁷/₈" , or 41⁷/₈" ; actual depths are 17⁷/₈" or 19⁷/₈" .

Notes

Credenza case height is 17⁵/₈" .

Lock is standard in drawer front.

For base height option (LB2), overall height is 3¹/₂" consisting of 1¹/₂" tube base with 2" legs.

Dimensional illustrations do not include all possible configurations.

To convert filing direction, order 1 of the following products separately:

- Front-to-back rail (9Pxxxx)
- Side-to-side rail (9Rxxxx)

See Stackable Lateral File Accessories for specific product number.

Order optional file drawer organizer (LG901) separately.

For work surface on top of 1 or more credenzas, order file top (TPL or TPV) separately.

For cushion tops (TC1) and (TC2), a 1" metal top is included.

Cushion top accepts Customer's Own Material (COM). Yardage is estimated for nondirectional, 54"-wide fabrics. When ordering more than 1 cushion, round up total yardage requirement to next whole yard of fabric.

Width—Yardage

30" —1.05

36" —1.22

42" —1.40

For information on multiple quantities or directional fabrics, contact

COM Department. See Order Information in Appendices.

For keyed-alike locks, order lock plugs separately. See Keyed-Alike Information in Appendices.

Dimensions

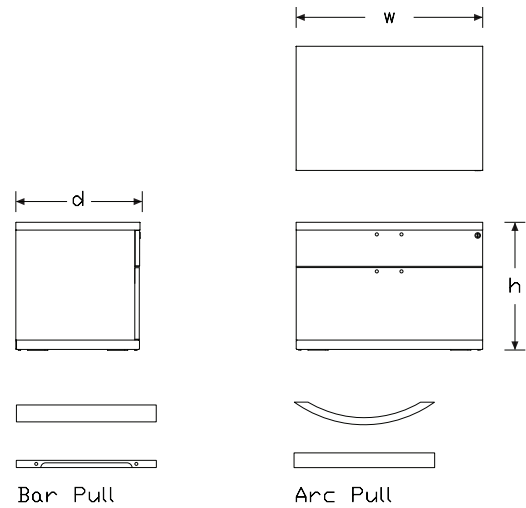

Meridian® Credenza Arc/Bar Pull

| Specification Information | | | |
|---------------------------|---------------|----------|----------|
| Step 1. | | | |
| C2 | | A | |
| Step 2. Pull | | | |
| A- | arc pull | A | |
| K- | bar pull | A | |
| Step 3. Width | | | |
| 30 | 30" wide | A | |
| 36 | 36" wide | A | |
| 42 | 42" wide | A | |
| Step 4. Depth | | | |
| 18- | 18" deep | A | |
| 20- | 20" deep | A | |
| Step 5. Configuration | | | |
| BF | box/file | A | |
| Step 6. Front Material | | | |
| M | painted metal | A | |
| V | vener | A | |
| Prices for Steps 1-6. | | | |
| | | M | V |
| C2A-30 | 18- BF | \$803 | 1238 |
| | 20- BF | \$803 | 1238 |
| | | M | V |
| C2A-36 | 18- BF | \$876 | 1428 |
| | 20- BF | \$876 | 1428 |
| | | M | V |
| C2A-42 | 18- BF | \$972 | 1672 |
| | 20- BF | \$972 | 1672 |
| | | M | V |
| C2K-30 | 18- BF | \$803 | 1238 |
| | 20- BF | \$803 | 1238 |
| | | M | V |
| C2K-36 | 18- BF | \$876 | 1428 |
| | 20- BF | \$876 | 1428 |
| | | M | V |
| C2K-42 | 18- BF | \$972 | 1672 |

| | | | |
|---|--------------------------------|-------|-------|
| 20- BF | | \$972 | 1672 |
| Step 7. Paint/Steel Type | | | |
| SS | smooth paint on smooth steel | | +\$0 |
| TS | smooth paint on textured steel | | +\$35 |
| XS | textured paint on smooth steel | | +\$0 |
| Step 8. Surface Finish | | | |
| Nonmetallic Paint | | | |
| <i>For smooth paint on smooth steel (SS) or smooth paint on textured steel (TS)</i> | | | |
| 8Q | folkstone grey | | +\$0 |
| 91 | white | | +\$0 |
| 98 | studio white A | | +\$0 |
| 9J | sparrow | | +\$0 |
| BU | black umber | | +\$0 |
| G2 | graphite satin | | +\$0 |
| HF | inner tone light | | +\$0 |
| HT | inner tone | | +\$0 |
| LT | light tone | | +\$0 |
| LU | soft white | | +\$0 |
| MT | medium tone | | +\$0 |
| SG | slate grey | | +\$0 |
| WA | wheat | | +\$0 |
| WL | sandstone | | +\$0 |
| Metallic Paint | | | |
| <i>For smooth paint on smooth steel (SS) or smooth paint on textured steel (TS)</i> | | | |
| 1209 | platinum | | +\$65 |
| 1210 | hematite | | +\$65 |
| 1212 | bronzite | | +\$65 |
| CN | metallic champagne | | +\$65 |
| EH | metallic bronze | | +\$65 |
| MS | metallic silver | | +\$65 |
| Sand Texture Paint | | | |
| <i>For textured paint on smooth steel (XS)</i> | | | |
| 98 | studio white A | | +\$0 |
| Bright Sand Texture Paint | | | |
| <i>For textured paint on smooth steel (XS)</i> | | | |
| 91 | white | | +\$0 |
| CL | cool grey neutral | | +\$0 |
| G1 | graphite | | +\$0 |
| WN | warm grey neutral | | +\$0 |

Step 9. Top

For painted metal (M)

| | | |
|------------|---|--------|
| NT | no top | +\$0 |
| T2 | 1 1/4"-high painted metal top with squared edge | +\$0 |
| TL | 1 1/4"-high laminate top with vinyl edge | +\$72 |
| TR | 1 1/4"-high recut veneer top A | +\$147 |
| TF | 1 1/4"-high wood veneer top A | +\$152 |
| TC1 | 1" cushion top | +\$386 |
| TC2 | 2" cushion top | +\$386 |

For veneer (V)

| | | |
|------------|---|--------|
| NT | no top | +\$0 |
| T2 | 1 1/4"-high painted metal top with squared edge | +\$0 |
| TL | 1 1/4"-high laminate top with vinyl edge | +\$72 |
| TF | 1 1/4"-high wood veneer top A | +\$152 |
| TC1 | 1" cushion top | +\$386 |
| TC2 | 2" cushion top | +\$386 |

Step 10. Veneer Front Finish
For veneer (V) with no top (NT), 1 1/4"-high painted metal top with squared edge (T2), 1 1/4"-high laminate top with vinyl edge (TL), 1" cushion top (TC1), or 2" cushion top (TC2)

Wood Veneer

| | | |
|-----------|-----------------------------|-------|
| 2U | light brown walnut A | +\$56 |
| 40 | dark brown walnut A | +\$56 |
| ED | aged cherry A | +\$56 |
| EK | medium red walnut A | +\$56 |
| ET | clear on ash A | +\$56 |
| EV | walnut on ash A | +\$56 |
| UL | natural maple A | +\$56 |
| UX | walnut on cherry A | +\$56 |

Step 11.

Top Finish: Solid-Color Laminate

For 1 1/4"-high laminate top with vinyl edge (TL)

| | | |
|-----------|-------------------|------|
| 8Q | folkstone grey | +\$0 |
| 91 | white | +\$0 |
| CL | cool grey neutral | +\$0 |
| HF | inner tone light | +\$0 |
| HT | inner tone | +\$0 |
| LT | light tone | +\$0 |
| LU | soft white | +\$0 |
| WL | sandstone | +\$0 |
| WN | warm grey neutral | +\$0 |

Top Finish: Linen Laminate

For 1 1/4"-high laminate top with vinyl edge (TL)

| | | |
|------------|---------------|------|
| LBM | crisp linen | +\$0 |
| LBN | classic linen | +\$0 |
| LBP | casual linen | +\$0 |

Top Finish: Mesh Laminate

For 1 1/4"-high laminate top with vinyl edge (TL)

| | | |
|------------|-------------|------|
| LBK | pewter mesh | +\$0 |
| LBL | steel mesh | +\$0 |

Top Finish: Twill Laminate

For 1 1/4"-high laminate top with vinyl edge (TL)

| | | |
|------------|----------------|------|
| LBF | neutral twill | +\$0 |
| LBG | sarum twill | +\$0 |
| LBH | earthen twill | +\$0 |
| LBJ | graphite twill | +\$0 |
| LBQ | white twill | +\$0 |

Top Finish: Wood-Grain Laminate

For 1 1/4"-high laminate top with vinyl edge (TL)

| | | |
|------------|--------------------|------|
| 76 | light brown walnut | +\$0 |
| HM | natural maple | +\$0 |
| HP | light anigre | +\$0 |
| HX | aged cherry | +\$0 |
| HY | walnut on cherry | +\$0 |
| LA | light ash | +\$0 |
| LBA | clear on ash | +\$0 |
| LBB | oak on ash | +\$0 |
| LBC | walnut on ash | +\$0 |
| LBD | dark brown walnut | +\$0 |
| LBE | medium red walnut | +\$0 |
| LM | mahogany | +\$0 |

Top Finish: Zephyr Laminate

For 1 1/4"-high laminate top with vinyl edge (TL)

| | | |
|-----------|--------|------|
| 28 | canyon | +\$0 |
| 29 | misted | +\$0 |

Veneer Top Finish: Recut Veneer

For painted metal (M) with 1 1/4"-high recut veneer top (TR)

| | | |
|-----------|------------------------|------|
| RA | light ash A | +\$0 |
| RK | mahogany dark A | +\$0 |
| RM | mahogany A | +\$0 |

| Veneer Top Finish: Wood Veneer | | |
|--|---|-------|
| <i>For painted metal (M) with 1 1/4"-high wood veneer top (TF)</i> | | |
| 2U | light brown walnut <input type="checkbox"/> | +\$28 |
| 40 | dark brown walnut <input type="checkbox"/> | +\$28 |
| ED | aged cherry <input type="checkbox"/> | +\$28 |
| EK | medium red walnut <input type="checkbox"/> | +\$28 |
| ET | clear on ash <input type="checkbox"/> | +\$28 |
| EV | walnut on ash <input type="checkbox"/> | +\$28 |
| UL | natural maple <input type="checkbox"/> | +\$28 |
| UX | walnut on cherry <input type="checkbox"/> | +\$28 |

| Veneer Front/Top Finish: Wood Veneer | | |
|---|---|-------|
| <i>For veneer (V) with 1 1/4"-high wood veneer top (TF)</i> | | |
| 2U | light brown walnut <input type="checkbox"/> | +\$56 |
| 40 | dark brown walnut <input type="checkbox"/> | +\$56 |
| ED | aged cherry <input type="checkbox"/> | +\$56 |
| EK | medium red walnut <input type="checkbox"/> | +\$56 |
| ET | clear on ash <input type="checkbox"/> | +\$56 |
| EV | walnut on ash <input type="checkbox"/> | +\$56 |
| UL | natural maple <input type="checkbox"/> | +\$56 |
| UX | walnut on cherry <input type="checkbox"/> | +\$56 |

| Step 12. Edge Finish | | |
|--|--------------------|------|
| <i>For 1 1/4"-high laminate top with vinyl edge (TL)</i> | | |
| 28 | canyon | +\$0 |
| 29 | misted | +\$0 |
| 76 | light brown walnut | +\$0 |
| 8Q | folkstone grey | +\$0 |
| 91 | white | +\$0 |
| BU | black umber | +\$0 |
| CL | cool grey neutral | +\$0 |
| G2 | graphite satin | +\$0 |
| HF | inner tone light | +\$0 |
| HM | natural maple | +\$0 |
| HP | light anigre | +\$0 |
| HT | inner tone | +\$0 |
| HX | aged cherry | +\$0 |
| HY | walnut on cherry | +\$0 |
| LA | light ash | +\$0 |
| LBA | clear on ash | +\$0 |
| LBB | oak on ash | +\$0 |
| LBC | walnut on ash | +\$0 |
| LBD | dark brown walnut | +\$0 |
| LBE | medium red walnut | +\$0 |
| LBF | neutral twill | +\$0 |
| LBG | sarum twill | +\$0 |
| LBH | earthen twill | +\$0 |

| | | |
|------------|-------------------|------|
| LBJ | graphite twill | +\$0 |
| LBK | pewter mesh | +\$0 |
| LBL | steel mesh | +\$0 |
| LBM | crisp linen | +\$0 |
| LBN | classic linen | +\$0 |
| LBP | casual linen | +\$0 |
| LBQ | white twill | +\$0 |
| LM | mahogany | +\$0 |
| LU | soft white | +\$0 |
| MT | medium tone | +\$0 |
| SG | slate grey | +\$0 |
| WA | wheat | +\$0 |
| WL | sandstone | +\$0 |
| WN | warm grey neutral | +\$0 |

| Step 13. Cushion Top Fabric | |
|---|--------|
| <i>For 1" cushion top (TC1) or 2" cushion top (TC2)</i> | |
| <i>See application chart and textiles list for fabric usage and numbers.</i> | |
| <i>First 2 digits of number indicate fabric line; remaining digit(s) indicate fabric color.</i> | |
| Price Category 1 | +\$0 |
| Price Category 2 | +\$68 |
| Price Category 3 | +\$82 |
| Price Category 4 | +\$101 |
| Price Category 5 | +\$120 |
| Price Category 7 <input type="checkbox"/> | +\$137 |
| Price Category 9 | +\$950 |
| Price Category B | +\$47 |
| Price Category C | +\$43 |
| Price Category D | +\$82 |
| Price Category E | +\$99 |
| Price Category F | +\$99 |
| Price Category G | +\$166 |
| Price Category H | +\$204 |
| Price Category I | +\$211 |
| Price Category J | +\$276 |

| Step 14. Lock | | |
|---------------|---------------------------|------|
| KA | keyed alike | +\$0 |
| KC | keyed differently, chrome | +\$0 |
| KD | keyed differently, black | +\$0 |

| Step 15. Pull Finish | | |
|--------------------------|----------------|------|
| <i>For arc pull (A-)</i> | | |
| NH | brushed nickel | +\$0 |
| NK | black nickel | +\$0 |

For bar pull (K-)

| | | |
|------------|---|-------|
| 8Q | folkstone grey | +\$0 |
| 91 | white | +\$0 |
| G1 | graphite <input type="checkbox"/> A | +\$0 |
| WL | sandstone <input type="checkbox"/> A | +\$0 |
| CN | metallic champagne <input type="checkbox"/> A | +\$0 |
| MS | metallic silver | +\$0 |
| 79 | green apple <input type="checkbox"/> A | +\$10 |
| MY3 | yellow oxide <input type="checkbox"/> A | +\$10 |
| RO | red <input type="checkbox"/> A | +\$10 |
| TRQ | turquoise <input type="checkbox"/> A | +\$10 |

Step 16. Base Height

| | | |
|------------|---------------|-------|
| B3 | 2¼"-high base | +\$0 |
| LB2 | 1½" leg base | +\$33 |

Step 17. Leg*For 1½" leg base (LB2)*

| | | |
|-----------|---|--------|
| DD | 2"-high canvas leg <input type="checkbox"/> A | +\$122 |
|-----------|---|--------|

Step 18. Leg Finish

| | | |
|-----------|-------------------|------|
| 91 | white | +\$0 |
| CL | cool grey neutral | +\$0 |
| G1 | graphite | +\$0 |
| WN | warm grey neutral | +\$0 |

Metallic Paint

| | | |
|-----------|---|-------|
| CN | metallic champagne <input type="checkbox"/> A | +\$10 |
| EH | metallic bronze <input type="checkbox"/> A | +\$10 |
| MS | metallic silver <input type="checkbox"/> A | +\$10 |

Step 19. Counterweight

| | | |
|-----------|--|--------|
| NO | no counterweight (must gang or anchor) | +\$0 |
| CB | counterweight (recommended) | +\$119 |

Step 20. Drawer Interior

| | | |
|-----------|---------------------------|------|
| 9M | 3 dividers | +\$0 |
| 9P | front-to-back filing rail | +\$0 |
| 9R | side-to-side filing rail | +\$0 |

Meridian® File Top

TPL-0
TPL-1
TPV-0

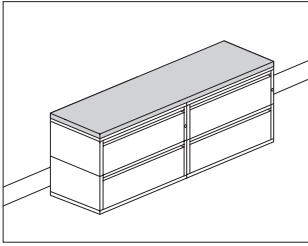

Product Information

Description

This file top attaches to a combination of freestanding Meridian® lateral files or storage cases with 18" or 20" depths. It has a laminate top with thermoplastic edge or a veneer top and edge.

Notes

Standard-pull files have lock located in side stile and do not require metal top under common top. Files with all other pull types will require metal top under common top to accommodate locks.

Suggested attachment methods:

- Double-face tape
- #10 wood screws with 1" maximum length

Additional sizes and open-line laminates available through Vary Easy Exact Size Top Price Book (specIT edition only).

Dimensions

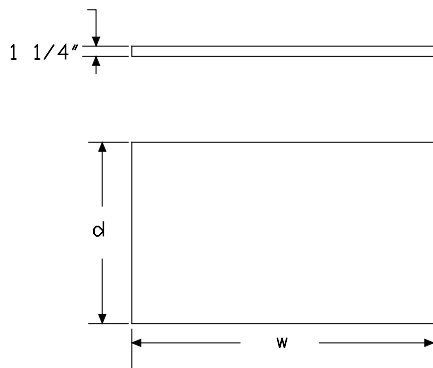

Specification Information

Step 1.

TP A

Step 2. Top/Edge Material

- L- laminate top with thermoplastic edge A
V- veneer top with veneer edge A

Step 3. Width

For laminate top with thermoplastic edge (L-)

- 030 30" wide A
036 36" wide A
042 42" wide A
060 60" wide A
072 72" wide A
084 84" wide A
090 90" wide A
108 108" wide A

For veneer top with veneer edge (V-)

- 030 30" wide A
036 36" wide A
042 42" wide A
060 60" wide A
072 72" wide A
084 84" wide A
090 90" wide A

Step 4. Depth

- 18 18" deep A
20 20" deep A
36 36" deep A
40 40" deep A

Prices for Steps 1-4.

| | | |
|---------|----|-------|
| TPL-030 | 18 | \$146 |
| | 20 | \$146 |
| | 36 | \$326 |
| | 40 | \$326 |
| TPL-036 | 18 | \$175 |
| | 20 | \$175 |
| | 36 | \$391 |
| | 40 | \$391 |

| | | |
|----------------|-----------|-------|
| TPL-042 | 18 | \$203 |
| | 20 | \$203 |
| | 36 | \$454 |
| | 40 | \$454 |

| | | |
|----------------|-----------|-------|
| TPL-060 | 18 | \$291 |
| | 20 | \$291 |
| | 36 | \$651 |
| | 40 | \$651 |

| | | |
|----------------|-----------|-------|
| TPL-072 | 18 | \$349 |
| | 20 | \$349 |
| | 36 | \$781 |
| | 40 | \$781 |

| | | |
|----------------|-----------|-------|
| TPL-084 | 18 | \$406 |
| | 20 | \$406 |
| | 36 | \$907 |
| | 40 | \$907 |

| | | |
|----------------|-----------|-------|
| TPL-090 | 18 | \$436 |
| | 20 | \$436 |
| | 36 | \$977 |
| | 40 | \$977 |

| | | |
|----------------|-----------|--------|
| TPL-108 | 18 | \$523 |
| | 20 | \$523 |
| | 36 | \$1172 |
| | 40 | \$1172 |

| | | |
|----------------|-----------|-------|
| TPV-030 | 18 | \$361 |
| | 20 | \$361 |
| | 36 | \$576 |
| | 40 | \$576 |

| | | |
|----------------|-----------|-------|
| TPV-036 | 18 | \$405 |
| | 20 | \$405 |
| | 36 | \$664 |
| | 40 | \$664 |

| | | |
|----------------|-----------|-------|
| TPV-042 | 18 | \$449 |
| | 20 | \$449 |
| | 36 | \$750 |
| | 40 | \$750 |

| | | |
|----------------|-----------|--------|
| TPV-060 | 18 | \$577 |
| | 20 | \$577 |
| | 36 | \$1008 |
| | 40 | \$1008 |

| | | |
|----------------|-----------|--------|
| TPV-072 | 18 | \$666 |
| | 20 | \$666 |
| | 36 | \$1183 |
| | 40 | \$1183 |

| | | |
|----------------|-----------|--------|
| TPV-084 | 18 | \$752 |
| | 20 | \$752 |
| | 36 | \$1356 |
| | 40 | \$1356 |

| | | |
|----------------|-----------|--------|
| TPV-090 | 18 | \$794 |
| | 20 | \$794 |
| | 36 | \$1439 |
| | 40 | \$1439 |

Step 5.

Top Finish: Solid-Color Laminate

For laminate top with thermoplastic edge (L-)

| | | |
|-----------|--|------|
| 8Q | folkstone grey <input type="checkbox"/> | +\$0 |
| 91 | white <input type="checkbox"/> | +\$0 |
| 98 | studio white | +\$0 |
| CL | cool grey neutral <input type="checkbox"/> | +\$0 |
| HF | inner tone light <input type="checkbox"/> | +\$0 |
| HT | inner tone <input type="checkbox"/> | +\$0 |
| LT | light tone <input type="checkbox"/> | +\$0 |
| LU | soft white <input type="checkbox"/> | +\$0 |
| WL | sandstone <input type="checkbox"/> | +\$0 |
| WN | warm grey neutral <input type="checkbox"/> | +\$0 |

Top Finish: Linen Laminate

For laminate top with thermoplastic edge (L-)

| | | |
|------------|---------------|------|
| LBM | crisp linen | +\$0 |
| LBN | classic linen | +\$0 |
| LBP | casual linen | +\$0 |

Top Finish: Mesh Laminate

For laminate top with thermoplastic edge (L-)

| | | |
|------------|-------------|------|
| LBK | pewter mesh | +\$0 |
| LBL | steel mesh | +\$0 |

| Top Finish: Twill Laminate | | |
|--|----------------|------|
| <i>For laminate top with thermoplastic edge (L-)</i> | | |
| LBF | neutral twill | +\$0 |
| LBG | sarum twill | +\$0 |
| LBH | earthen twill | +\$0 |
| LBJ | graphite twill | +\$0 |
| LBQ | white twill | +\$0 |

| Top Finish: Wood-Grain Laminate | | |
|--|--|------|
| <i>For laminate top with thermoplastic edge (L-)</i> | | |
| HM | natural maple A | +\$0 |
| HP | light anigre A | +\$0 |
| LA | light ash A | +\$0 |
| LBA | clear on ash | +\$0 |
| LBB | oak on ash | +\$0 |
| LBC | walnut on ash | +\$0 |
| LBD | dark brown walnut | +\$0 |
| LBE | medium red walnut | +\$0 |
| LM | mahogany A | +\$0 |
| 76 | light brown walnut A | +\$0 |
| HX | aged cherry A | +\$0 |
| HY | walnut on cherry A | +\$0 |

| Top Finish | | |
|--|--|------|
| <i>For laminate top with thermoplastic edge (L-)</i> | | |
| 28 | canyon A | +\$0 |
| 29 | misted A | +\$0 |

| Top/Edge Finish: Wood Veneer | | |
|---|--|--------|
| <i>For veneer top with veneer edge (V-)</i> | | |
| 2U | light brown walnut A | +\$105 |
| 40 | dark brown walnut A | +\$105 |
| ED | aged cherry A | +\$105 |
| EK | medium red walnut A | +\$105 |
| ET | clear on ash A | +\$105 |
| EU | oak on ash A | +\$105 |
| EV | walnut on ash A | +\$105 |
| UL | natural maple A | +\$105 |
| UX | walnut on cherry A | +\$105 |

| Top/Edge Finish: Recut Veneer | | |
|---|---|------|
| <i>For veneer top with veneer edge (V-)</i> | | |
| RA | light ash A | +\$0 |
| RK | mahogany dark A | +\$0 |
| RM | mahogany A | +\$0 |

| Step 6. Edge Finish | | |
|--|--|------|
| <i>For laminate top with thermoplastic edge (L-)</i> | | |
| LT | light tone A | +\$0 |
| 28 | canyon A | +\$0 |
| 29 | misted A | +\$0 |
| 76 | light brown walnut A | +\$0 |
| 8Q | folkstone grey A | +\$0 |
| 91 | white A | +\$0 |
| 98 | studio white | +\$0 |
| BU | black umber A | +\$0 |
| CL | cool grey neutral A | +\$0 |
| G2 | graphite satin A | +\$0 |
| HF | inner tone light A | +\$0 |
| HM | natural maple A | +\$0 |
| HP | light anigre A | +\$0 |
| HT | inner tone A | +\$0 |
| HX | aged cherry A | +\$0 |
| HY | walnut on cherry A | +\$0 |
| LA | light ash A | +\$0 |
| LBA | clear on ash | +\$0 |
| LBB | oak on ash | +\$0 |
| LBC | walnut on ash | +\$0 |
| LBD | dark brown walnut | +\$0 |
| LBE | medium red walnut | +\$0 |
| LBK | pewter mesh A | +\$0 |
| LBL | steel mesh A | +\$0 |
| LBM | crisp linen A | +\$0 |
| LBN | classic linen A | +\$0 |
| LBP | casual linen A | +\$0 |
| LBF | neutral twill A | +\$0 |
| LBG | sarum twill A | +\$0 |
| LBH | earthen twill A | +\$0 |
| LBJ | graphite twill A | +\$0 |
| LBQ | white twill A | +\$0 |
| LM | mahogany A | +\$0 |
| LU | soft white A | +\$0 |
| MT | medium tone A | +\$0 |
| SG | slate grey A | +\$0 |
| WA | wheat A | +\$0 |
| WL | sandstone A | +\$0 |
| WN | warm grey neutral A | +\$0 |

Meridian® Storage Surround Top

FSTL-
FSTU-
FSTV-

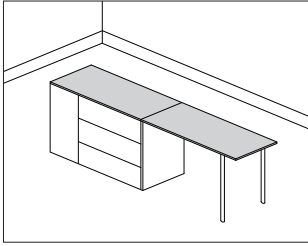

Product Information

Description

This surround top attaches to a combination of freestanding Meridian® lateral files or storage cases with 18" or 20" depths. It has a laminate top with thermoplastic edge, laminate top with a thermoplastic backed plywood edge, or veneer top and edge. Attachment hardware included.

Notes

Laminate tops up to and including 108" wide are 1-piece tops, and 120" wide and wider are 2-piece tops with connecting hardware.

Veneer tops up to and including 90" wide are 1-piece tops, and 108" wide and wider are 2-piece tops with connecting hardware.

Files with standard pulls have lock located in side stile and do not require metal top under common top. Files with all other pull types will require metal top under common top to accommodate locks.

Tops are required to be secured to storage case with the supplied #10 wood screws with 1" maximum length.

When using storage surround top (FST) independently of storage surround end (FSE), the top will oversail the end panel 1 1/4".

Dimensions

60", 72", 84", 90", 108"



120", 126", 144", 150", 168", 180"

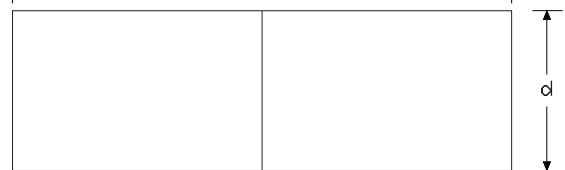

laminate top

60", 72", 84", 90"



108", 120", 126", 144", 150", 168", 180"



veneer top

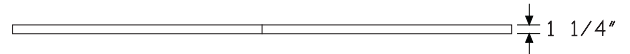

Meridian® File Surrounds

Meridian® Storage Surround Top

continued

Meridian® File Surrounds

Specification Information

Step 1.

FST

Step 2. Top/Edge Material

L- laminate top with thermoplastic edge

V- veneer top with veneer edge

U- laminate top with universal edge

Step 3. Width

060 60" wide

072 72" wide

084 84" wide

090 90" wide

108 108" wide

120 120" wide

126 126" wide

144 144" wide

150 150" wide

168 168" wide

180 180" wide

Step 4. Depth

18 18" deep

20 20" deep

36 36" deep

40 40" deep

Prices for Steps 1-4.

| | 18 | 20 | 36 | 40 |
|------------------|-----------|-----------|-----------|-----------|
| FSTL- 060 | \$318 | 318 | 651 | 651 |
| 072 | \$375 | 375 | 781 | 781 |
| 084 | \$433 | 433 | 911 | 911 |
| 090 | \$462 | 462 | 976 | 976 |
| 108 | \$548 | 548 | 1171 | 1171 |
| 120 | \$1216 | 1216 | 1665 | 1665 |
| 126 | \$1245 | 1245 | 1730 | 1730 |
| 144 | \$1331 | 1331 | 1925 | 1925 |
| 150 | \$1360 | 1360 | 1989 | 1989 |
| 168 | \$1447 | 1447 | 2184 | 2184 |
| 180 | \$1504 | 1504 | 2314 | 2314 |

| | | | | |
|------------------|--------|------|------|------|
| FSTV- 060 | \$672 | 672 | 1116 | 1116 |
| 072 | \$761 | 761 | 1289 | 1289 |
| 084 | \$849 | 849 | 1462 | 1462 |
| 090 | \$894 | 894 | 1549 | 1549 |
| 108 | \$1571 | 1571 | 1924 | 1924 |
| 120 | \$1660 | 1660 | 2259 | 2259 |
| 126 | \$1704 | 1704 | 2184 | 2184 |
| 144 | \$1837 | 1837 | 2444 | 2444 |
| 150 | \$1881 | 1881 | 2530 | 2530 |
| 168 | \$2014 | 2014 | 2790 | 2790 |
| 180 | \$2103 | 2103 | 2963 | 2963 |

| | | | | |
|------------------|--------|------|------|------|
| FSTU- 060 | \$318 | 318 | 651 | 651 |
| 072 | \$375 | 375 | 781 | 781 |
| 084 | \$433 | 433 | 911 | 911 |
| 090 | \$462 | 462 | 976 | 976 |
| 108 | \$548 | 548 | 1171 | 1171 |
| 120 | \$1216 | 1216 | 1665 | 1665 |
| 126 | \$1245 | 1245 | 1730 | 1730 |
| 144 | \$1331 | 1331 | 1925 | 1925 |
| 150 | \$1360 | 1360 | 1989 | 1989 |
| 168 | \$1447 | 1447 | 2184 | 2184 |
| 180 | \$1504 | 1504 | 2314 | 2314 |

Step 5. Top Finish

Solid-Color Laminate

For laminate top with thermoplastic edge (L-) or laminate top with universal edge (U-)

| | | |
|-----------|--|------|
| 8Q | folkstone grey <input type="checkbox"/> | +\$0 |
| 91 | white <input type="checkbox"/> | +\$0 |
| CL | cool grey neutral <input type="checkbox"/> | +\$0 |
| HF | inner tone light <input type="checkbox"/> | +\$0 |
| HT | inner tone <input type="checkbox"/> | +\$0 |
| LT | light tone <input type="checkbox"/> | +\$0 |
| LU | soft white <input type="checkbox"/> | +\$0 |
| WL | sandstone <input type="checkbox"/> | +\$0 |
| WN | warm grey neutral <input type="checkbox"/> | +\$0 |

Linen Laminate

For laminate top with thermoplastic edge (L-) or laminate top with universal edge (U-)

| | | |
|------------|---------------|------|
| LBM | crisp linen | +\$0 |
| LBN | classic linen | +\$0 |
| LBP | casual linen | +\$0 |

Meridian® Storage Surround Top

continued

Mesh Laminate

For laminate top with thermoplastic edge (L-) or laminate top with universal edge (U-)

| | | |
|------------|-------------|------|
| LBK | pewter mesh | +\$0 |
| LBL | steel mesh | +\$0 |

Twill Laminate

For laminate top with thermoplastic edge (L-) or laminate top with universal edge (U-)

| | | |
|------------|----------------|------|
| LBF | neutral twill | +\$0 |
| LBG | sarum twill | +\$0 |
| LBH | earthen twill | +\$0 |
| LBJ | graphite twill | +\$0 |
| LBQ | white twill | +\$0 |

Wood-Grain Laminate

For laminate top with thermoplastic edge (L-) or laminate top with universal edge (U-)

| | | |
|------------|--------------------------------------|------|
| HM | natural maple A | +\$0 |
| HP | light anigre A | +\$0 |
| LA | light ash A | +\$0 |
| LBA | clear on ash | +\$0 |
| LBB | oak on ash | +\$0 |
| LBC | walnut on ash | +\$0 |
| LBD | dark brown walnut | +\$0 |
| LBE | medium red walnut | +\$0 |
| LM | mahogany A | +\$0 |
| 76 | light brown walnut A | +\$0 |
| HX | aged cherry A | +\$0 |
| HY | walnut on cherry A | +\$0 |

Zephyr Laminate

For laminate top with thermoplastic edge (L-) or laminate top with universal edge (U-)

| | | |
|-----------|--------------------------|------|
| 28 | canyon A | +\$0 |
| 29 | misted A | +\$0 |

Wood Veneer

For veneer top with veneer edge (V-)

| | | |
|-----------|--|--------|
| V3 | cherry A | +\$82 |
| Z3 | warm red cherry A | +\$82 |
| Z5 | maple A | +\$82 |
| 2U | light brown walnut A | +\$105 |
| 3U | medium red cherry A | +\$105 |
| 40 | dark brown walnut A | +\$105 |
| 6U | chocolate brown sapele A | +\$105 |
| ED | aged cherry A | +\$105 |
| EG | medium brown walnut A | +\$105 |
| EK | medium red walnut A | +\$105 |
| ET | clear on ash A | +\$105 |
| EU | oak on ash A | +\$105 |
| EV | walnut on ash A | +\$105 |
| UL | natural maple A | +\$105 |
| UQ | light cherry A | +\$105 |
| UV | red cherry A | +\$105 |
| UX | walnut on cherry A | +\$105 |

Recut Veneer

For veneer top with veneer edge (V-)

| | | |
|-----------|---------------------------------|------|
| RA | light ash A | +\$0 |
| RK | mahogany dark A | +\$0 |
| RM | mahogany A | +\$0 |

Step 6. Edge Finish

For laminate top with thermoplastic edge (L-)

| | | |
|------------|--------------------------------------|------|
| 28 | canyon A | +\$0 |
| 29 | misted A | +\$0 |
| 76 | light brown walnut A | +\$0 |
| 8Q | folkstone grey A | +\$0 |
| 91 | white A | +\$0 |
| BU | black umber A | +\$0 |
| CL | cool grey neutral A | +\$0 |
| G2 | graphite satin A | +\$0 |
| HF | inner tone light A | +\$0 |
| HM | natural maple A | +\$0 |
| HP | light anigre A | +\$0 |
| HT | inner tone A | +\$0 |
| HX | aged cherry A | +\$0 |
| HY | walnut on cherry A | +\$0 |
| LA | light ash A | +\$0 |
| LBA | clear on ash | +\$0 |
| LBB | oak on ash | +\$0 |
| LBC | walnut on ash | +\$0 |

Meridian® Storage Surround Top

continued

Meridian® File Surrounds

| | | |
|------------|--|------|
| LBD | dark brown walnut | +\$0 |
| LBE | medium red walnut | +\$0 |
| LBK | pewter mesh <input type="checkbox"/> A | +\$0 |
| LBL | steel mesh <input type="checkbox"/> A | +\$0 |
| LBM | crisp linen <input type="checkbox"/> A | +\$0 |
| LBN | classic linen <input type="checkbox"/> A | +\$0 |
| LBP | casual linen <input type="checkbox"/> A | +\$0 |
| LBF | neutral twill <input type="checkbox"/> A | +\$0 |
| LBG | sarum twill <input type="checkbox"/> A | +\$0 |
| LBH | earthen twill <input type="checkbox"/> A | +\$0 |
| LBJ | graphite twill <input type="checkbox"/> A | +\$0 |
| LBQ | white twill <input type="checkbox"/> A | +\$0 |
| LM | mahogany <input type="checkbox"/> A | +\$0 |
| LU | soft white <input type="checkbox"/> A | +\$0 |
| MT | medium tone <input type="checkbox"/> A | +\$0 |
| SG | slate grey <input type="checkbox"/> A | +\$0 |
| WA | wheat <input type="checkbox"/> A | +\$0 |
| WL | sandstone <input type="checkbox"/> A | +\$0 |
| WN | warm grey neutral <input type="checkbox"/> A | +\$0 |

For laminate top with universal edge (U-)

| | | |
|------------|---|-------|
| PLY | plywood edge <input type="checkbox"/> A | +\$50 |
|------------|---|-------|

Meridian® Storage Surround Ends

FSEL-
FSEV-

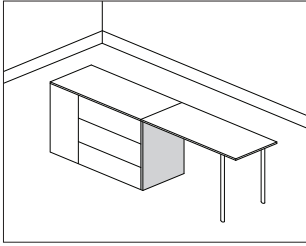

Product Information

Description

This surround end attaches to a combination of freestanding Meridian® lateral files or storage cases with 18" or 20" depths. It has a laminate top with thermoplastic edge or a veneer top and edge. Attachment hardware included.

Notes

Pricing is for a single file end.

Surround end is attached to storage case only. Ends are not designed to support a surround top at the open end.

Surround end heights are designed to align with the following case, base, and top specifications:

- 37—aligns with 35³/₈" case height with 2¹/₄" base and no top
- 38—aligns with 35³/₈" case height with 2¹/₄" base and 1¹/₄" top
- 41—aligns with 39³/₈" case height with 2¹/₄" base and no top
- 42—aligns with 39³/₈" case height with 2¹/₄" base and 1¹/₄" top

Files with standard pulls have lock located in side stile and do not require metal top under common top. Files with all other pull types will require metal top under common top to accommodate locks. When ordering tops, consider the thickness of end panel (1¹/₄") to allow top over design.

Ends are secured to storage case with the supplied #10 wood screws with 1" maximum length.

Additional sizes and open-line laminates available through Vary Easy Exact Size Top Price Book (SpecIT edition only).

Dimensions

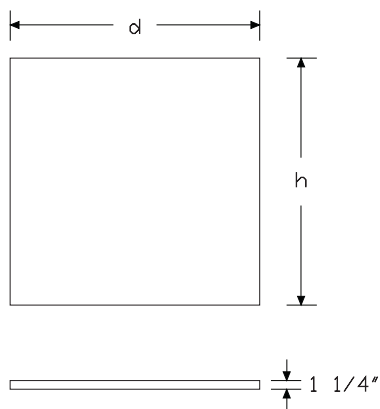

Specification Information

Step 1.

FSE A

Step 2. End/Edge Material

L- laminate end with thermoplastic edge A

V- veneer end with veneer edge A

Step 3. Height

37 37.5" high A

38 38.75" high A

41 41.625" high A

42 42.875" high A

Step 4. Depth

18 18" deep A

20 20" deep A

36 36" deep A

40 40" deep A

Prices for Steps 1-4.

| | | 18 | 20 | 36 | 40 |
|--------------|-----------|-------|-----|-----|-----|
| FSEL- | 37 | \$268 | 268 | 382 | 382 |
| | 38 | \$273 | 273 | 387 | 387 |
| | 41 | \$279 | 279 | 392 | 392 |
| | 42 | \$284 | 284 | 397 | 397 |
| FSEV- | 37 | \$588 | 588 | 835 | 835 |
| | 38 | \$598 | 598 | 845 | 845 |
| | 41 | \$608 | 608 | 855 | 855 |
| | 42 | \$618 | 618 | 866 | 866 |

Step 5.

End Finish: Solid-Color Laminate

For laminate end with thermoplastic edge (L-)

| | | |
|-----------|---|------|
| 8Q | folkstone grey A | +\$0 |
| 91 | white A | +\$0 |
| CL | cool grey neutral A | +\$0 |
| HF | inner tone light A | +\$0 |
| HT | inner tone A | +\$0 |
| LT | light tone A | +\$0 |
| LU | soft white A | +\$0 |
| WL | sandstone A | +\$0 |
| WN | warm grey neutral A | +\$0 |

Meridian® Storage Surround Ends

continued

Meridian® File Surrounds

| | | |
|--|--|------|
| End Finish: Frosted Laminate | | |
| <i>For laminate end with thermoplastic edge (L-)</i> | | |
| J4 | frosted light grey A | +\$0 |
| J5 | frosted inner tone light A | +\$0 |
| J7 | frosted medium tone A | +\$0 |

| | | |
|--|---|------|
| End Finish: Linen Laminate | | |
| <i>For laminate end with thermoplastic edge (L-)</i> | | |
| LBM | crisp linen A | +\$0 |
| LBN | classic linen A | +\$0 |
| LBP | casual linen A | +\$0 |

| | | |
|--|---|------|
| End Finish: Mesh Laminate | | |
| <i>For laminate end with thermoplastic edge (L-)</i> | | |
| LBK | pewter mesh A | +\$0 |
| LBL | steel mesh A | +\$0 |

| | | |
|--|--|------|
| End Finish: Twill Laminate | | |
| <i>For laminate end with thermoplastic edge (L-)</i> | | |
| LBF | neutral twill A | +\$0 |
| LBG | sarum twill A | +\$0 |
| LBH | earthen twill A | +\$0 |
| LBJ | graphite twill A | +\$0 |
| LBQ | white twill A | +\$0 |

| | | |
|--|--|------|
| End Finish: Wood-Grain Laminate | | |
| <i>For laminate end with thermoplastic edge (L-)</i> | | |
| 76 | light brown walnut A | +\$0 |
| HM | natural maple A | +\$0 |
| HP | light anigre A | +\$0 |
| HX | aged cherry A | +\$0 |
| HY | walnut on cherry A | +\$0 |
| LA | light ash A | +\$0 |
| LBA | clear on ash A | +\$0 |
| LBB | oak on ash A | +\$0 |
| LBC | walnut on ash A | +\$0 |
| LBD | dark brown walnut A | +\$0 |
| LBE | medium red walnut A | +\$0 |
| LM | mahogany A | +\$0 |

| | | |
|--|--|------|
| End Finish: Zephyr Laminate | | |
| <i>For laminate end with thermoplastic edge (L-)</i> | | |
| 28 | canyon A | +\$0 |
| 29 | misted A | +\$0 |

| | | |
|---|--|-------|
| End/Edge Finish: Wood Veneer | | |
| <i>For veneer end with veneer edge (V-)</i> | | |
| V3 | cherry A | +\$0 |
| Z3 | warm red cherry A | +\$0 |
| Z5 | maple A | +\$0 |
| 2U | light brown walnut A | +\$82 |
| 3U | medium red cherry A | +\$82 |
| 40 | dark brown walnut A | +\$82 |
| 6U | chocolate brown sapele A | +\$82 |
| ED | aged cherry A | +\$82 |
| EG | medium brown walnut A | +\$82 |
| EK | medium red walnut A | +\$82 |
| ET | clear on ash A | +\$82 |
| EU | oak on ash A | +\$82 |
| EV | walnut on ash A | +\$82 |
| UL | natural maple A | +\$82 |
| UQ | light cherry A | +\$82 |
| UV | red cherry A | +\$82 |
| UX | walnut on cherry A | +\$82 |

| | | |
|---|---|------|
| End/Edge Finish: Recut Veneer | | |
| <i>For veneer end with veneer edge (V-)</i> | | |
| RA | light ash A | +\$0 |
| RK | mahogany dark A | +\$0 |
| RM | mahogany A | +\$0 |

| | | |
|--|--|------|
| Step 6. Edge Finish | | |
| <i>For laminate end with thermoplastic edge (L-)</i> | | |
| 28 | canyon A | +\$0 |
| 29 | misted A | +\$0 |
| 76 | light brown walnut A | +\$0 |
| 8Q | folkstone grey A | +\$0 |
| 91 | white A | +\$0 |
| BU | black umber A | +\$0 |
| CL | cool grey neutral A | +\$0 |
| G2 | graphite satin A | +\$0 |
| HF | inner tone light A | +\$0 |
| HM | natural maple A | +\$0 |
| HP | light anigre A | +\$0 |
| HT | inner tone A | +\$0 |
| HX | aged cherry A | +\$0 |
| HY | walnut on cherry A | +\$0 |
| LA | light ash A | +\$0 |
| LBA | clear on ash | +\$0 |
| LBB | oak on ash | +\$0 |
| LBC | walnut on ash | +\$0 |
| LBD | dark brown walnut | +\$0 |

Meridian® Storage Surround Ends

continued

| | | |
|------------|--|------|
| LBE | medium red walnut | +\$0 |
| LBK | pewter mesh <input type="checkbox"/> | +\$0 |
| LBL | steel mesh <input type="checkbox"/> | +\$0 |
| LBM | crisp linen <input type="checkbox"/> | +\$0 |
| LBN | classic linen <input type="checkbox"/> | +\$0 |
| LBP | casual linen <input type="checkbox"/> | +\$0 |
| LBF | neutral twill <input type="checkbox"/> | +\$0 |
| LBG | sarum twill <input type="checkbox"/> | +\$0 |
| LBH | earthen twill <input type="checkbox"/> | +\$0 |
| LBJ | graphite twill <input type="checkbox"/> | +\$0 |
| LBQ | white twill <input type="checkbox"/> | +\$0 |
| LM | mahogany <input type="checkbox"/> | +\$0 |
| LU | soft white <input type="checkbox"/> | +\$0 |
| MT | medium tone <input type="checkbox"/> | +\$0 |
| SG | slate grey <input type="checkbox"/> | +\$0 |
| WA | wheat <input type="checkbox"/> | +\$0 |
| WL | sandstone <input type="checkbox"/> | +\$0 |
| WN | warm grey neutral <input type="checkbox"/> | +\$0 |

Meridian® Storage Surround
Support Legs

FSLR-
FSL-

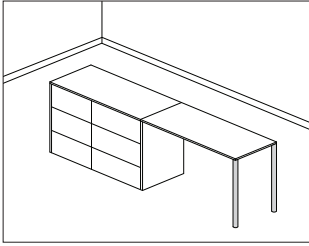

Product Information

Description

This metal leg attaches to a surround top in lieu of a surround end panel. Each leg has an adjustable glide with 1½" of height adjustment. Specified and shipped as a pair (2).

Surround legs are designed to align with the following case, base, and top specifications:

- 37—aligns with 35¼" case height with 2¼" base and no top
- 38—aligns with 35¼" case height with 2¼" base and 1¼" top
- 41—aligns with 39¾" case height with 2¼" base and no top
- 42—aligns with 39¾" case height with 2¼" base and 1¼" top

Notes

Legs are used to support 1 end of file surround top (FSTL-, FSLV-), and leg height matches height of file surround end panel (FSEL-, FSEV-).

Meridian® File Surrounds

Dimensions

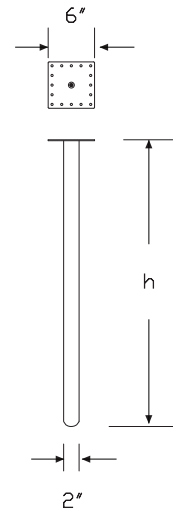

round

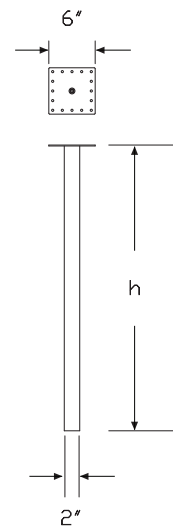

square

Meridian® Storage Surround

Support Legs *continued*

Specification Information

Step 1.

FSL

Step 2. Leg Style

R- round

S- square

Step 3. Height

37 37.5" high

38 38.75" high

41 41.625" high

42 42.875" high

Prices for Steps 1-3.

| | | |
|--------------|-----------|-------|
| FSLR- | 37 | \$299 |
| | 38 | \$299 |
| | 41 | \$325 |
| | 42 | \$325 |

| | | |
|--------------|-----------|-------|
| FSLS- | 37 | \$402 |
| | 38 | \$402 |
| | 41 | \$423 |
| | 42 | \$423 |

Step 4. Paint/Steel Type

SS smooth paint on smooth steel +\$0

XS textured paint on smooth steel +\$0

Step 5. Surface Finish

Bright Sand Texture Paint

For textured paint on smooth steel (XS)

91 white +\$0

G1 graphite +\$0

Metallic Paint

For smooth paint on smooth steel (SS)

MS metallic silver +\$10

Front-to-Back Filing Rail,
Meridian® Stackable™ Lateral File

9P001
9P002
9P361
9P362

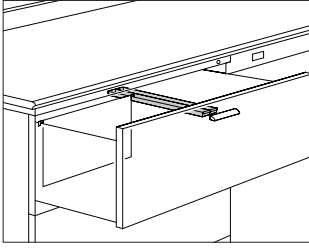

Product Information

Description

This filing rail holds letter-size hanging folders for front-to-back filing. The 16" rail is used in an 18"-deep Meridian® lateral file drawer. The 18" rail is used in the file drawer of a Meridian Stackable Storage™ cabinet bottom module, 20"-deep Meridian lateral file, or Meridian lateral storage tower.

Notes

Front-to-back filing rail cannot be used in Tu® or Quadrant® lateral file drawers.

Dimensions

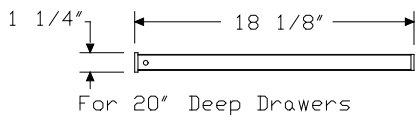
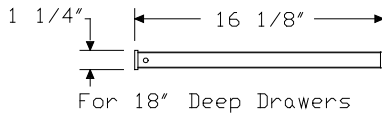
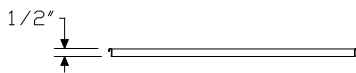

Specification Information

Step 1.

9P

Step 2. Width

00 for 30"- or 42"-wide drawers
36 for 36"-wide drawers

Step 3. Depth

18 18" deep
20 20" deep

Prices for Steps 1-3.

| | |
|---------------|------|
| 9P0018 | \$27 |
| 9P0020 | \$27 |
| 9P3618 | \$27 |
| 9P3620 | \$27 |

Side-to-Side Filing Rail, Meridian® Stackable™ Lateral File

- 9R124
- 9R130
- 9R136
- 9R142
- 9R224
- 9R230
- 9R236
- 9R242

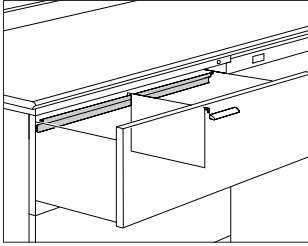

Product Information

Description

This filing rail holds letter- or legal-size hanging folders for side-to-side filing. The 21"-wide rail is used in the file drawer of a 24"-wide Meridian® Stackable Storage™ cabinet bottom module. The 27"-wide rail is used in the file drawer of a 30"-wide Meridian Stackable Storage cabinet bottom module, Meridian lateral file, or Meridian lateral storage tower. The 33"-wide rail is used in the file drawer of a 36"-wide Meridian lateral file. The 39"-wide rail is used in the file drawer of a 42"-wide Meridian lateral file.

Notes

Side-to-side filing rail cannot be used in Tu® or Quadrant® lateral file drawers.

Dimensions

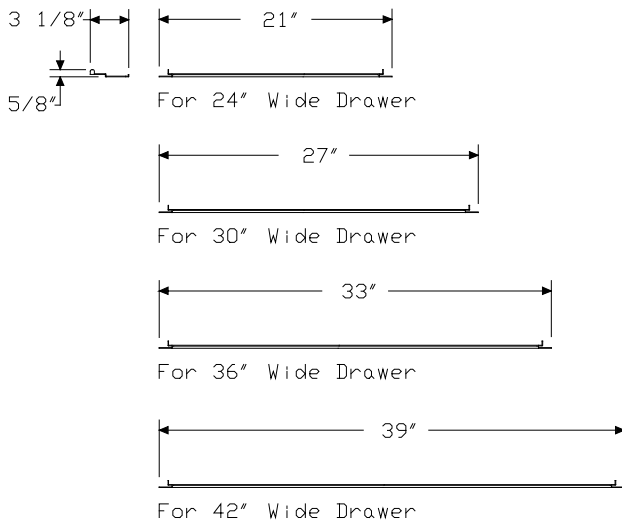

Specification Information

Step 1.

9R

Step 2. Quantity

- 1** 1 filing rail
- 2** 2 filing rails

Step 3. Width

- 2400** for 24"-wide drawers
- 3000** for 30"-wide drawers
- 3600** for 36"-wide drawers
- 4200** for 42"-wide drawers

Prices for Steps 1-3.

| | |
|----------------|------|
| 9R12400 | \$20 |
| 9R13000 | \$20 |
| 9R13600 | \$20 |
| 9R14200 | \$20 |
| 9R22400 | \$40 |
| 9R23000 | \$40 |
| 9R23600 | \$40 |
| 9R24200 | \$40 |

Meridian® Stackable™ Lateral File Accessories

Movable Divider, Meridian®,
 Quadrant® or Tu®

9M100
 9M300

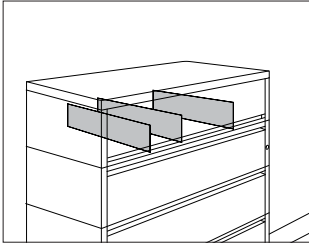

Product Information

Description

This adjustable metal divider fits into slots of an 18" or 20"-deep Meridian® Stackable™ lateral file drawer. The 18"-deep divider also fits into a pullout shelf's slots on a Tu® or Quadrant® 5-high lateral file. Finish is black umber.

Dimensions

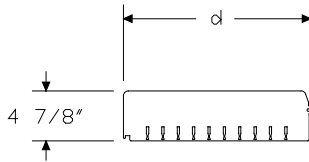

Specification Information

Step 1.

9M

Step 2. Quantity

- 100** 1 divider
- 300** 3 dividers

Step 3. Depth

- 18** for Meridian® 18"-deep Stackable™ lateral file modules or Quadrant® 20" deep flipper door with pullout shelf
- 20** for Meridian® 20" deep Stackable™ lateral file modules

Prices for Steps 1-3.

| | | |
|--------------|-----------|------|
| 9M100 | 18 | \$14 |
| | 20 | \$14 |
| 9M300 | 18 | \$34 |
| | 20 | \$34 |

File Drawer Organizer

LG901

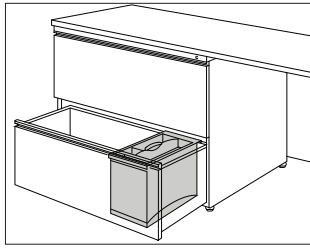

Product Information

Description

This 2-sectioned organizer fits into any file drawer arranged for letter-size filing. The removable top section stores computer disks and other small items. The bottom section stores larger items or can be divided into 3 compartments; it includes 2 vertical dividers. Finish is black umber.

Dimensions

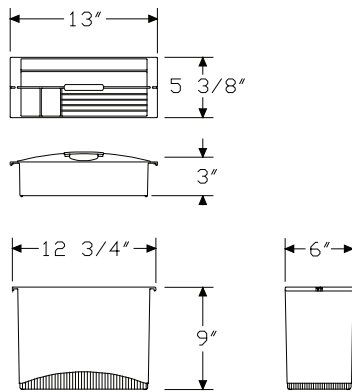

Specification Information

Step 1.

LG901

\$77

EnhancedAccess™ Pull

EAP-L

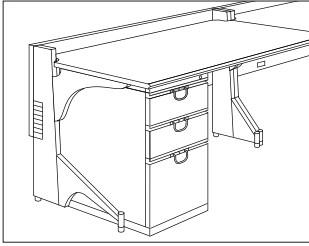

Product Information

Description

This plastic loop-style pull slides into the standard pull or Tu® W-pull on a pedestal or lateral file drawer. It makes the drawer easier to open. Package contains 1 pull and attachment hardware.

Dimensions

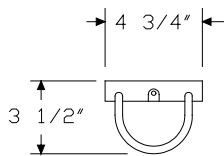

Specification Information

Step 1.

EAP-

Step 2. Pull Style

L loop

Prices for Steps 1-2.

EAP-L \$54

Step 3. Finish

BU black umber +\$0
HF inner tone light +\$0
MT medium tone +\$0

Label Holders-Snap In and Adhesive

9LH5H
9LH7H

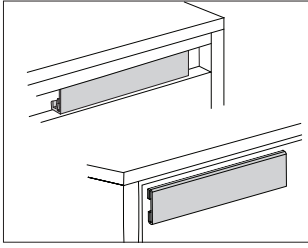

Product Information

Description

These label holders snap in place for standard pull file drawers or attach with adhesive onto drawers with other pull styles. Package contains 25 of the specified style. Labels included.

Dimensions

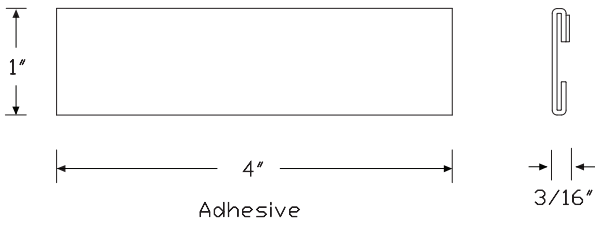
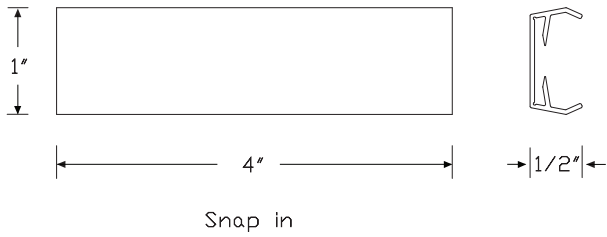

Specification Information

Step 1.

9LH A

Step 2. Style

5HV snap in A

7HT adhesive A

Prices for Steps 1-2.

| | |
|--------|------|
| 9LH5HV | \$19 |
| 9LH7HT | \$17 |

Keyless Lock

MKL-H
 MKL-V
 MKS-H
 MKS-V

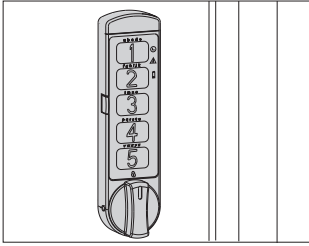

Product Information

Description

This keyless lock replaces an existing cam lock and is available in 2 mode options. Locker mode allows for a temporary code to be entered for each use, and station mode allows for repeated use with the same code. Multiple orientation options allow the keyless lock to be used with a variety of products.

Notes

Replacement battery is a 3-volt lithium CR2032 battery.

Actual lock dimensions are 3.86"W×1.00"H×0.39"D.

Order the following products separately:

- Control key fob (MKL-CKF)
- User key fob (MKL-UKF)

Dimensions

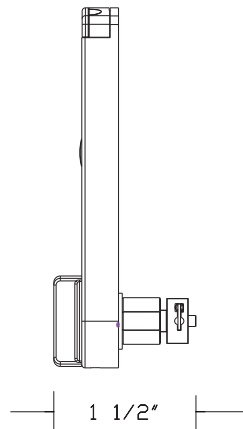
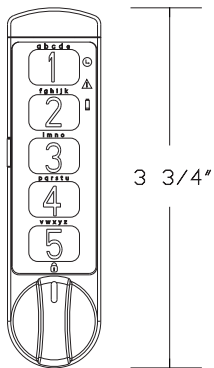
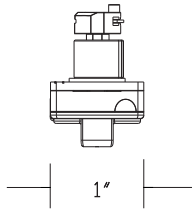

Specification Information

Step 1.

MK

Step 2. Mode

L- locker mode

S- station mode

Step 3. Orientation

HL horizontal, keypad facing left

HR horizontal, keypad facing right

VU vertical, keypad facing up

VD vertical, keypad facing down

Prices for Steps 1-3.

| | |
|--------|-------|
| MKL-HL | \$197 |
| MKL-HR | \$197 |
| MKL-VU | \$197 |
| MKL-VD | \$197 |
| MKS-HL | \$197 |
| MKS-HR | \$197 |
| MKS-VU | \$197 |
| MKS-VD | \$197 |

Step 4. Finish

| | |
|------------------------------------|------|
| OI silver <input type="checkbox"/> | +\$0 |
| BK black <input type="checkbox"/> | +\$0 |



Product Information

Description

This key fob opens the keyless lock without using the numeric keypad.

Notes

Order the following products separately:

- Keyless lock (MK)
- User key fob (MKL-UKF)

Dimensions

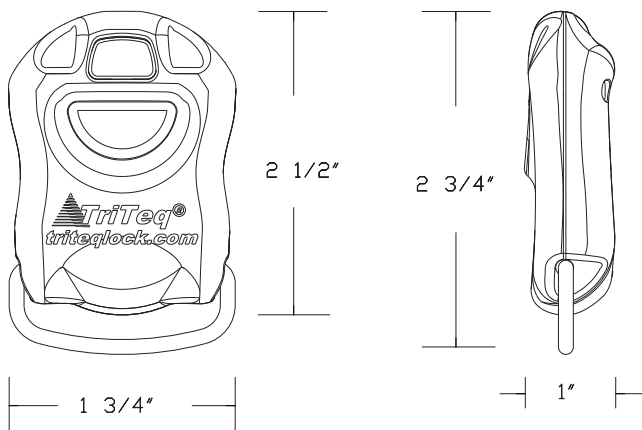

Specification Information

Step 1.

MKL-CKF A

\$167



Product Information

Description

This key fob opens the keyless lock without using the numeric keypad.

Notes

Order the following products separately:

- Keyless lock (MK)
- Control key fob (MKL-CKF)

Dimensions

Meridian® Keyless Locks

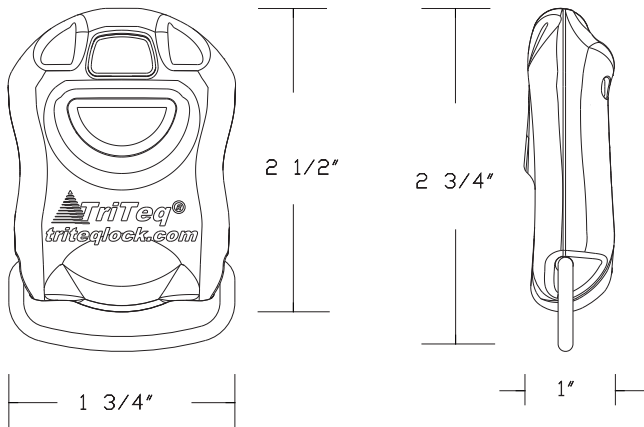

Specification Information

Step 1.

MKL-UKF A

\$167

Index by Product Name

| Meridian® Lateral Files | |
|--|------------|
| Arc-Pull Freestanding Lateral File | page(s) 30 |
| Bar-Pull Freestanding Lateral File | 36 |
| Bevel-Pull Freestanding Lateral File | 42 |
| Bevel-Pull Mobile Lateral File | 64 |
| Ellipse-Pull Freestanding Lateral File | 47 |
| EnhancedAccess™ Pull | 90 |
| File Drawer Organizer | 89 |
| Front-to-Back Filing Rail, Meridian® Stackable™ Lateral File | 86 |
| Keyless Lock | 92 |
| Keyless Lock, Control Key Fob | 93 |
| Keyless Lock, User Key Fob | 94 |
| Label Holders-Snap In and Adhesive | 91 |
| Meridian® File Top | 74 |
| Meridian® Low Credenza | 69 |
| Meridian® Storage Surround Ends | 81 |
| Meridian® Storage Surround Support Legs | 84 |
| Meridian® Storage Surround Top | 77 |
| Movable Divider, Meridian®, Quadrant® or Tu® | 88 |
| Retrofit Cushion Top | 58 |
| Side-to-Side Filing Rail, Meridian® Stackable™ Lateral File | 87 |
| Sloped-Pull Freestanding Lateral File | 52 |
| Standard-Pull Freestanding Lateral File | 25 |
| Standard-Pull Mobile Lateral File | 60 |



Index by Product Number

| | | | | | |
|-------|--|------------|-------|---|----|
| 24-30 | Bevel-Pull Freestanding Lateral File | page(s) 42 | FSLR- | Meridian® Storage Surround Support Legs | 84 |
| 24-36 | | | FSLS- | | |
| 24-42 | | | FSTL- | Meridian® Storage Surround Top | 77 |
| 26-30 | Standard-Pull Freestanding Lateral File | 25 | FSTU- | | |
| 26-36 | | | FSTV- | | |
| 26-42 | | | LG901 | File Drawer Organizer | 89 |
| 29P-3 | Sloped-Pull Freestanding Lateral File | 52 | M24-3 | Bevel-Pull Mobile Lateral File | 64 |
| 29P-4 | | | M24-4 | | |
| 29V-3 | | | M26-3 | Standard-Pull Mobile Lateral File | 60 |
| 29V-4 | | | M26-4 | | |
| 2A-30 | Arc-Pull Freestanding Lateral File | 30 | MKL-C | Keyless Lock, Control Key Fob | 93 |
| 2A-36 | | | MKL-H | Keyless Lock | 92 |
| 2A-42 | | | MKL-U | Keyless Lock, User Key Fob | 94 |
| 2D-30 | | | MKL-V | Keyless Lock | 92 |
| 2D-36 | | | MKS-H | | |
| 2D-42 | | | MKS-V | | |
| 2J-30 | Ellipse-Pull Freestanding Lateral File | 47 | TC1-3 | Retrofit Cushion Top | 58 |
| 2J-36 | | | TC1-4 | | |
| 2J-42 | | | TC2-3 | | |
| 2KP-3 | Bar-Pull Freestanding Lateral File | 36 | TC2-4 | | |
| 2KP-4 | | | TPL-0 | Meridian® File Top | 74 |
| 2KV-3 | | | TPL-1 | | |
| 2KV-4 | | | TPV-0 | | |
| 9LH5H | Label Holders-Snap In and Adhesive | 91 | | | |
| 9LH7H | | | | | |
| 9M100 | Movable Divider, Meridian®, Quadrant® or Tu® | 88 | | | |
| 9M300 | | | | | |
| 9P001 | Front-to-Back Filing Rail, Meridian® Stackable™ Lateral File | 86 | | | |
| 9P002 | | | | | |
| 9P361 | | | | | |
| 9P362 | | | | | |
| 9R124 | Side-to-Side Filing Rail, Meridian® Stackable™ Lateral File | 87 | | | |
| 9R130 | | | | | |
| 9R136 | | | | | |
| 9R142 | | | | | |
| 9R224 | | | | | |
| 9R230 | | | | | |
| 9R236 | | | | | |
| 9R242 | | | | | |
| C2A-3 | Meridian® Low Credenza | 69 | | | |
| C2A-4 | | | | | |
| C2K-3 | | | | | |
| C2K-4 | | | | | |
| EAP-L | EnhancedAccess™ Pull | 90 | | | |
| FSEL- | Meridian® Storage Surround Ends | 81 | | | |
| FSEV- | | | | | |



20-Day or Less/Assigned Lead-Time Order Information

20-Day or Less and Assigned Lead-Time Programs

20-day or less and assigned lead-time products are designed for established Herman Miller dealers with pre-approved credit.

Products are distributed from multiple manufacturing facilities across the United States. All products and options not designated by an Assigned Lead-Time icon **A** will ship in 20 business days or less after being acknowledged by Herman Miller. Products and options designated by an **A** are on the assigned lead-time program and will ship in 20 days, less than 20 days, or more than 20 days from order acknowledgement.

Ordering Procedure

Please place orders through Order Manager. If this is not available to you, place orders through mail or fax. Verbal purchase orders will not be accepted.

Order Entry fax number for Passage®, 5000 Series, and Meridian® Filing and Storage: (616) 846 9236.

Order Entry fax number for all other products:
(616) 654 3085.

For more information, contact your Customer Care representative at:
(866) 854 3048 EXT 3400.

Shipments and Delivery

Per Herman Miller Terms and Conditions.

Changes and Cancellation

Per Herman Miller Terms and Conditions.



Keyed-Alike Information

Keyed-Alike Locks

All components with locks may be specified keyed alike. Products with keyed-alike locks will be shipped with lock chassis installed.

Installation of lock cylinders will be on-site according to instructions provided. Herman Miller, Inc., will not be responsible for lock cylinder installation.

When specifying product keyed-alike, include separate lines on your order for the lock cylinders.

For Action Office®, Ethospace®, Passage®, Quadrant®, Resolve®, and Supplemental products, list cylinder part number and key number (232092-XXX); select a key number (or numbers) between 226 and 427, excluding numbers 408 and 412.

The following products require a different lock cylinder part number. Specify UKY001-XXX for these products only; select a key number (or numbers) between 226 and 427, excluding numbers 408 and 412.

- A3013.
- A3053.
- G5180.
- G5181.
- G5280.

The keys provided in 232092-XXX and UKY001-XXX kits work with either cylinder type, provided the key numbers match.

For Tu® Storage, Canvas Office Landscape®, 5000 Series, and Meridian® Storage, see the following charts.

Keyed-alike locks are field installed.

To order keyed-alike locks for Action Office® Series 1 and 2 door panels, please contact Customer Care.

A master key can be used to open any lock on an attached or freestanding component. In addition, a removal key or lock change tool is required to remove lock plugs. Customers interested in ordering master keys, removal keys, or lock change tools should contact Customer Care.

For Canvas overhead and lower storage units, specify as follows:

| Specification Code | Part Number | Color | Lock Series |
|--------------------|-------------------------|--------|-------------------|
| KA | 1B2JK7-XXX ¹ | chrome | UM series 226-427 |

For Canvas Metal Storage, Meridian Storage, Tu Storage, and 5000 Series desk components with pedestals, specify as follows:

| Specification Code | Key Number | Color | Lock Series |
|--------------------|-------------------------|--------|-------------------|
| KA | 232092-XXX ¹ | black | UM series 226-427 |
| KA | 1B2JK7-XXX ¹ | chrome | UM series 226-427 |

For 5000 Series flipper door unit with bezel or credenza storage cabinet with bezel, specify as follows:

| Specification Code | Key Number | Color | Lock Series |
|--------------------|-------------------------|-------|-------------------|
| KA | 232092-XXX ¹ | black | UM series 226-427 |

Key Number:

XXX¹ = a key number between 226 and 427 (excluding 408 and 412)

Vary Easy Program

Program Overview

Vary Easy is a program designed to help dealers specify standard products with a larger breadth of options. For example, depending on the type of product being specified, choices include additional size, finish, edge types, and cable management features. Vary Easy 3D, specIT, and third-party text-based specification packages support the Vary Easy program. Vary Easy 3D enables designers to create a 3D image, CAD symbols, and a price book page. A Vary Easy product number is assigned for each product as the user selects specific options. Once the product is completely specified, the order can be submitted via Kiosk's Order Manager or a dealer's business system.

Accessing and Specifying Vary Easy

To view the full product vocabulary, go to the Vary Easy Product Offering on Kiosk. To specify Vary Easy, go to the Vary Easy 3D website on Kiosk, specIT, or your third-party text-based specification package.

Once you've made your product line selection, continue to follow through each option and enter the specific options that represent the product you need. When the product is fully specified, Vary Easy will generate an orderable product number and instantly calculate a price.

Note: Failure to completely specify a product will cause a delay in order acknowledgements. Be sure to make a selection for all options offered.

The acknowledgement process for Vary Easy products is the same as for any standard order. Vary Easy products ship with a standardized lead time and are competitively priced.

For more information, contact your Customer Care Line at (866) 854 3048 EXT 3400.

Stain-to-Match Program

Stain-to-Match Program

Program Overview

The Stain-to-Match program gives you the option of using veneer finishes that are not listed in the standard offering. The program allows Herman Miller to match a customer's existing recut or natural veneer, or create a new finish that is unique to an installation.

Specific information on approval, ordering, pricing, and warranty for the Stain-to-Match program is listed below. Questions and requests for assistance may be directed to Herman Miller Options at:

(800) 654 3910

Ordering Products with Stain-to-Match Veneers

1. Fill out the Options Stain-to-Match Request Form and send along with a color sample (2" x 3" minimum) to the Herman Miller Options Applications Team at the address provided on the form. The form can be found on Omni.
2. Within 7-10 working days, Herman Miller Options will send a sample of the color-matched stain on Herman Miller veneer to the requester for the customer's signed approval.
3. If the sample meets the customer's approval, sign the reverse side of the sample, scan and email the approval to:
options@hermanmiller.com.
4. After the stain has been approved, a formal quotation with special number and pricing can be provided, or the product can be specified through the Vary Easy program, if available. Work with the Options team on final product needs and how to specify.
5. A purchase order can then be placed.

Stain-to-Match Warranty

Herman Miller warrants its products to be free from defects in craftsmanship from the date of delivery for the applicable warranty period. Herman Miller is responsible for the physical properties of the veneers available through the Stain-to-Match program, which include:

- STA: Stain-to-Match on Recut Ash
- STB: Stain-to-Match on Beech
- STC: Stain-to-Match on Cherry
- STD: Stain-to-Match on Oak
- STK: Stain-to-Match on Reltech Anigre (Geiger)
- STM: Stain-to-Match on Recut Mahogany
- STP: Stain-to-Match on Maple
- STU: Stain-to-Match on Walnut (Geiger)

See your specification tool for product specific finish offering limitations.



Customer's Own Material/ Customer's Own Leather Order Information — Cushion Tops

Customer's Own Material/Customer's Own Leather

Program Overview

The Customer's Own Material (COM) and Customer's Own Leather (COL) program gives you the option of using textiles other than those listed. Herman Miller will test textiles for application to Herman Miller products and will process orders for those with approved COM/COL textiles only. COM/COL are assigned lead time textiles.

Omni lists an overview of fabrics and leathers that have been tested and indicates whether or not they were approved for application to Herman Miller products.

Specific information on the terms and conditions, testing, approval, and ordering process for COM/COL is listed below. Questions about the COM/COL program and requests for assistance may be directed to your COM representative at:

(616) 654 3400

(866) 854 3048 EXT 6543400

Customer's Own Material/Customer's Own Leather Warranty

Herman Miller does not warrant COM/COL textiles. COM/COL textiles are tested for application only; they are not tested for performance. The Herman Miller warranty does apply to the underlying products.

Suppliers of COM/COL textiles are responsible for color consistency within commercial tolerances, UV stability, and resistance to soiling and perspiration.

Customer's Own Material/Customer's Own Leather Pricing

COM is a Category 1 fabric. There are no application charges for COM fabrics. COL is a Category 7 textile; refer to prices on specific products to determine the application charge.

Ordering and payment for COM/COL textile yardage are the responsibility of the customer and the textile supplier.

If desired, Herman Miller will purchase COM textiles directly from True Textiles, C.F. Stinson, Luna Textiles, Maharam, and Momentum Textiles to simplify ordering and shipment. For this service, refer to the Supplier Connection program.

Application Note

Herman Miller does not guarantee that Customer's Own Material (COM) fabric patterns will align across panels/tiles or from one screen to the next. We also do not guarantee that COM fabric designs will be positioned consistently in the same location across several panels, tiles, or screens.

Textile Approval

1. Select a COM/COL textile.
2. If your textile is not listed on Omni, obtain a test number from a COM representative at (616) 654 3400. You can also submit your request within Omni. Please have the following information ready before calling: textile name, number, pattern, and the product you will apply it to.
3. Herman Miller will notify you of approval or disapproval within 4 days from receipt of the test yardage.

Customer's Own Material/ Customer's Own Leather Order Information — Cushion Tops

continued

Ordering Products with COM/COL

1. Refer to the specific products to determine the yardage required for COM/COL textiles.
2. If your textile is not listed on Omni, call a COM representative at (616) 654 3400 or (866) 854 3048 EXT 6543400. The representative will assign an identification number for your textile (ID#) and will verify yardage requirements for your order. Yardage requirements are based on directional, 54"-wide textiles. Additional yardage may be needed due to the unique characteristics of a textile.
3. Enter your order on Order Manager in Omni.
4. Upon receipt of your purchase order, Herman Miller will send you a PO acknowledgment.
5. Arrangements must be made for the textiles to be shipped from the supplier to Herman Miller for application to the seating products. See Omni for shipping procedures and current shipping addresses or contact a COM representative at (616) 654 3400 or (866) 854 3048 EXT 6543400.

Products will be scheduled for production when COM/COL textiles are received at Herman Miller. Standard lead times in effect at that time will apply.

Note: If textiles are to be purchased directly by Herman Miller through the Supplier Connection program, Herman Miller will handle the ordering and shipping process and will schedule your order for production upon receipt of your purchase order (dependent on textile availability). Refer to the Supplier Connection program for more information.

Supplier Connection

Program Overview

The Supplier Connection program is a service offered by Herman Miller to purchase approved COM textiles directly from True Textiles, C.F. Stinson, Luna Textiles, Maharam, and Momentum Textiles. When you select a textile through this program, Herman Miller will facilitate the ordering, scheduling, and shipment of the textile directly with the supplier.

Suppliers included in the Supplier Connection program keep an active inventory of textiles that are pre-approved for application to Herman Miller products. Pre-approval applies only to the suitability of a textile for manufacturing and application to a Herman Miller product. Omni provides an overview of fabrics that have been tested and indicates whether or not they were approved for application to Herman Miller products.

Specific information on the terms and conditions, testing, approval, and ordering process for the Supplier Connection program is listed below. Questions and requests for assistance may be directed to your COM representative at:

(616) 654 3400
(866) 854 3048 EXT 6543400

Supplier Connection Warranty

Textiles purchased by Herman Miller through the Supplier Connection program are COM and are not warranted by Herman Miller. COM textiles are tested for application only; they are not tested for performance. The Herman Miller warranty does apply to the underlying products.

Suppliers of COM textiles are responsible for color consistency within commercial tolerances, UV stability, and resistance to soiling and perspiration.

Customer's Own Material/ Customer's Own Leather Order Information — Cushion Tops

continued

Supplier Connection Pricing

Textiles purchased by Herman Miller through the Supplier Connection program are COM. COM is a Category 1 fabric. There are no application charges for COM fabrics.

Payment for textiles purchased by Herman Miller through the Supplier Connection program is the responsibility of the customer or dealer. Herman Miller will invoice the order at the supplier's prices published at the time of the order.

Textile Approval

1. Refer to Omni to identify the approval status of the textile. If your textile is not listed, contact the COM Department to request testing for application to Herman Miller products.
2. Herman Miller will notify you of approval or disapproval in approximately 4 days from receipt of the test yardage. If the textile is approved, it will be assigned a COM identification number.

Ordering Products with Supplier Connection COM

1. Identify and include the following information on your purchase order:
 - Product number and option
 - Herman Miller's COM identification number
2. Enter your order on Order Manager in Omni.
3. Upon receipt of the purchase order, Herman Miller will process your order and send you a PO acknowledgment. Herman Miller will determine the yardage required to produce your product and will order and schedule for delivery the required textile. Standard lead times in effect at the time the textile is allocated at the supplier will apply to products ordered through this program.



Proprietary Textiles Application Chart – Seating

• Available

[A] Assigned lead-time textile.

See following page for exception notes.

[N] Non-woven textile.

Price Category 1

| | New Aeron® Chairs | Classic Aeron Work Chairs/Stools | Classic Aeron Armrads/Arm Kit | Mirra® 2 Chairs/Stools | Celle® Chairs/Stools | Embody® Chairs | Sayl® Work Chairs/Stools | Sayl Side Chairs | Setu® Chairs/Stools | Setu Lounge Chair/Ottoman | Verus™ Work Chairs/Stools Back | Verus Work Chairs/Stools Seat | Verus Side Chairs Back | Verus Side Chairs Seat | Ergon 3® Chairs | Ergon 3/Equa 2® Adjustable Arm Kit | Equa 2 Fully Upholstered Chairs/Stools | Equa 2 Split-Pad Upholstered Chairs/Stools | Aside® Chairs | Cape® Chairs/Stools | Celeste™ Seating | Keyn Chair Group | Locale® Bench Cushion | Public Office Landscape® Back | Public Office Landscape Seat | Plex™ Lounge Furniture | Swoop™ Lounge Seating - Fully Upholstered | Swoop Lounge Seating - Plywood | Eames Tandem Sling Seating | Cushion Tops | Workspaces |
|---------------------------------|-------------------|----------------------------------|-------------------------------|------------------------|----------------------|----------------|--------------------------|------------------|---------------------|---------------------------|--------------------------------|-------------------------------|------------------------|------------------------|-----------------|------------------------------------|--|--|---------------|---------------------|------------------|------------------|-----------------------|-------------------------------|------------------------------|------------------------|---|--------------------------------|----------------------------|--------------|------------|
| COM Customer's Own Material [A] | | | | | 14 | | 1 | 1 | | | | | | | 1 | | 1 | 1 | 1 | | 1 | 1 | 1 | | | 1 | 1 | 1 | 1 | 1 | 1 |
| 231__ 8Z Pellicle® | • | | | | | | | | | | | | | | | | | | | | | | | | | | | | | | |
| 1A7__ AireWeave™ 2 | | | | • | | | | | | | | | | | | | | | | | | | | | | | | | | | |
| 3P__ ColorGuard [N] | | | | | 15 | | • | 22 | • | • | | • | • | • | 2 | | | 3 | 8 | | • | • | • | | | | | | | | |
| 8T__ Crossing | | | | | • | | | | • | • | | | | | | | | | | | | | | | | | | | | | |
| 6V__ Flexnet™ | | | | | | | | | | | | | | | | | | | | | | | | | | | | | | | |
| 95__ Gem | | | | | 14 | | | | • | • | | | | | | | | | | | | | | | | | | | | | |
| 65__ Interweave | | | | | | | | | | | | | | | | | | | | | | | | | | | | | | | |
| 4W__ Lyris 2™ | | | | | | | | | | • | • | | | | | | | | | | | | | | | | | | | | |
| 1MN__ Monologue | | | | | 14 | | 21 | 22 | • | • | | • | | | • | • | | | | | | • | • | • | | • | • | • | • | • | • |
| 3D__ Pellicle® Classic (3V__) | | | • | | | | | | | | | | | | | | | | | | | | | | | | | | | | |
| 3DK__ Stretch Knit [A] | | | | | | | | 21 | | | | | | | | | | | | | | | | | | | | | | | |
| 235__ Tailored [A] | | | | | • | | • | • | • | | | • | • | • | | | | | | | | • | • | | • | • | | | | | |
| 1WS__ Whisper | | | | | 14 | | 21 | • | • | • | | • | • | • | | | | | | | | • | • | • | | • | • | • | • | • | • |

Price Category 2

| | | | | | | | | | | | | | | | | | | | | | | | | | | | | | | | |
|-----------------------------|--|--|---|--|----|----|----|----|----|---|---|---|---|---|--|--|---|---|---|--|---|---|---|---|---|---|---|----|---|---|---|
| 92__ Crepe | | | | | • | | • | • | • | • | | • | • | • | | | • | • | • | | • | • | • | | • | • | • | • | • | • | |
| 22Q__ Fish Net | | | | | • | | • | • | • | • | | • | • | • | | | • | • | • | | • | • | • | | • | • | • | • | • | • | • |
| 1LM__ Loom | | | | | 14 | | • | • | | | • | • | • | | | | | | | | | | • | • | | • | • | • | • | • | • |
| 1MV__ Marvel | | | | | 14 | | 21 | • | | | • | • | • | | | | | 8 | | | | • | • | • | | • | • | • | • | • | • |
| 1HA__ Medley | | | | | 14 | | • | • | 22 | | • | • | • | • | | | • | • | • | | • | • | • | | • | • | • | • | • | • | • |
| 3A__ Moiré | | | | | 14 | | • | • | • | • | | • | • | • | | | • | • | • | | • | • | • | | • | • | • | • | • | • | • |
| 4M__ Pellicle Tuxedo (4Q__) | | | • | | | | | | | | | | | | | | | | | | | | | | | | | | | | |
| 4E__ Pellicle Waves (4F__) | | | • | | | | | | | | | | | | | | | | | | | | | | | | | | | | |
| 30__ Rhythm | | | | | • | 23 | • | • | | | • | • | • | | | | • | • | | | | • | • | • | | • | • | • | • | • | • |
| 1RV__ Rivet | | | | | 14 | | 21 | 22 | | | • | • | • | • | | | | | | | | • | • | • | | • | • | • | • | • | • |
| 8R__ Twist | | | | | • | | • | • | • | • | | • | • | • | | | | | | | | • | • | • | | • | • | • | • | • | • |
| 22T__ Well Suited | | | | | | | | | | | | | | | | | | 8 | | | | | | | | | | 23 | | | • |

Price Category 3

| | | | | | | | | | | | | | | | | | | | | | | | | | | | | | | | |
|------------------------|--|--|--|--|----|--|---|---|---|---|---|---|---|---|--|---|---|---|---|--|---|---|---|---|---|---|---|---|---|---|---|
| 70__ Bento | | | | | | | • | • | • | • | | • | • | 2 | | • | • | 8 | | | • | | | | | | | | | | • |
| 8M__ Latitude™ | | | | | 23 | | • | • | | | | | | | | | 3 | | | | | | | | | | | | | | |
| 22R__ Pins and Needles | | | | | 14 | | • | • | • | | • | • | • | | | | • | • | | | • | • | | • | • | | • | • | • | • | • |
| 8U__ Stitches | | | | | • | | • | • | • | • | | • | • | • | | | • | • | • | | • | • | • | | • | • | • | • | • | • | • |
| 22V__ String Plaid | | | | | 14 | | • | • | | | | | | | | | | • | | | | • | • | • | | • | • | • | • | • | • |

Price Category 4

| | | | | | | | | | | | | | | | | | | | | | | | | | | | | | | | |
|----------------|--|--|--|--|----|--|----|----|----|---|---|---|---|---|--|--|---|---|---|--|---|---|---|---|---|---|---|---|---|---|---|
| 7Y__ Bingo [N] | | | | | | | • | • | • | • | | • | • | 2 | | | 3 | 8 | | | • | • | • | | | | | | | | • |
| 1DL__ Dialogue | | | | | | | | | | | | | | | | | | | | | | | | | | | | | | | |
| 213__ Mercer | | | | | 14 | | • | • | 22 | | • | • | • | | | | | | | | | • | • | | • | • | | | | | |
| 1A9__ Network | | | | | | | | | | | | | | | | | | | | | | | | • | | | | | | | |
| 6J__ Plateau | | | | | | | | | | | | | | | | | | | | | | | | | | | | | | | |
| 6S__ Quilty | | | | | 14 | | • | • | | | • | • | • | • | | | • | • | | | | • | • | • | | • | • | • | • | • | • |
| 8Y__ Spools | | | | | 14 | | 21 | • | • | • | | • | • | • | | | • | • | • | | • | • | • | | • | • | • | • | • | • | • |
| 22P__ Strata | | | | | | | 21 | 22 | • | | • | • | • | • | | | | | | | | • | • | • | | • | • | • | • | • | • |

Price Category 5

| | | | | | | | | | | | | | | | | | | | | | | | | | | | | | | | |
|-------------------------|--|--|--|--|----|--|---|----|---|---|---|---|---|---|--|--|---|---|---|--|---|---|---|--|---|---|---|---|---|---|---|
| 14A__ Hopsak | | | | | 14 | | • | 22 | • | • | • | • | • | • | | | • | • | • | | • | • | • | | • | • | • | • | • | • | • |
| 22N__ Noble (22H__) [A] | | | | | 14 | | • | 23 | • | • | • | • | • | • | | | • | 3 | 8 | | • | • | • | | • | • | • | • | • | • | • |

Price Category 6

| | | | | | | | | | | | | | | | | | | | | | | | | | | | | | | | |
|--------------|--|--|--|--|--|--|---|--|--|--|--|--|--|--|--|--|--|--|--|--|--|--|--|--|--|--|--|--|--|--|--|
| 35__ Balance | | | | | | | • | | | | | | | | | | | | | | | | | | | | | | | | |
|--------------|--|--|--|--|--|--|---|--|--|--|--|--|--|--|--|--|--|--|--|--|--|--|--|--|--|--|--|--|--|--|--|

Price Category 7

| | | | | | | | | | | | | | | | | | | | | | | | | | | | | | | | |
|--------------------------------|--|---|---|---|----|--|--|--|--|--|--|--|--|--|---|---|---|---|---|--|--|---|--|--|--|--|--|--|--|--|---|
| COL Customer's Own Leather [A] | | 1 | 1 | 1 | 14 | | | | | | | | | | 1 | 1 | 1 | 1 | 8 | | | 1 | | | | | | | | | 1 |
|--------------------------------|--|---|---|---|----|--|--|--|--|--|--|--|--|--|---|---|---|---|---|--|--|---|--|--|--|--|--|--|--|--|---|

Price Category 8

| | | | | | | | | | | | | | | | | | | | | | | | | | | | | | | | |
|-----------------------------------|--|--|--|--|--|--|--|--|--|--|--|--|--|--|--|--|--|--|--|--|--|--|--|--|--|--|--|--|--|--|--|
| No fabrics available at this time | | | | | | | | | | | | | | | | | | | | | | | | | | | | | | | |
|-----------------------------------|--|--|--|--|--|--|--|--|--|--|--|--|--|--|--|--|--|--|--|--|--|--|--|--|--|--|--|--|--|--|--|

Price Category 9

| | | | | | | | | | | | | | | | | | | | | | | | | | | | | | | | |
|--------------|--|--|--|--|----|--|--|--|--|--|--|--|--|--|--|--|---|---|---|---|--|---|---|--|--|--|--|--|--|--|---|
| 21__ Leather | | | | | 14 | | | | | | | | | | | | • | • | • | 8 | | 4 | • | | | | | | | | • |
|--------------|--|--|--|--|----|--|--|--|--|--|--|--|--|--|--|--|---|---|---|---|--|---|---|--|--|--|--|--|--|--|---|

continued on next page

Proprietary Textiles Application Chart – Seating

continued

• Available

[A] Assigned lead-time textile.

See below for exception notes.

[N] Non-woven textile.

Fire-Retardant Chairs/Fabrics

Price Category 1

COM Customer's Own Material [A]

1A7__ AireWeave™ 2

3P__ ColorGuard [N]

8T__ Crossing

6V__ Flexnet™

95__ Gem

4W__ Lyris 2™

3D__ Pellicle® Classic

235__ Tailored [A]

Price Category 2

92__ Crepe

22Q__ Fish Net

3A__ Moiré

30__ Rhythm

8R__ Twist

Price Category 3

70__ Bento

8M__ Latitude™

22R__ Pins and Needles

8U__ Stitches

22V__ String Plaid

Price Category 4

6J__ Plateau

6S__ Quilty

Price Category 5

14A__ Hopsak

Price Category 6

35__ Balance

Price Category 9

21__ Leather

| | Classic Aeron® Work Chairs/Stools | Mirra® 2 Chairs/Stools with Butterfly Back | Celle® Chairs/Stools | Embody® Chairs | Sayl® Work Chairs/Stools | Sayl Side Chairs | Setu® Chairs/Stools | Setu Lounge Chair/Ottoman | Ergon 3® Chairs | Equa 2® Fully Upholstered Chairs/Stools | Equa 2 Split-Pad Upholstered Chairs/Stools | Aside® Chairs | Caper® Chairs/Stools | Celeste™ Seating | Plex™ Lounge Furniture | Swoop™ Lounge Seating - Fully Upholstered | Eames® Tandem Sling Seating |
|------------------------|-----------------------------------|--|----------------------|----------------|--------------------------|------------------|---------------------|---------------------------|-----------------|---|--|---------------|----------------------|------------------|------------------------|---|-----------------------------|
| COM | | | | | | | | | 1 | 1 | 1 | 1 | | 1 | | | |
| 1A7__ AireWeave™ 2 | • | | | | | | | | | | | | | | | | |
| 3P__ ColorGuard [N] | | 15 | 24 | 22 | | | | 2 | | 3 | 8 | | | | | • | 6 |
| 8T__ Crossing | | 14 | | | • | • | • | • | • | • | • | | | • | | • | |
| 6V__ Flexnet™ | | | | | | | | | | | | • | | | | | |
| 95__ Gem | | 14 | | | • | • | • | • | • | • | • | | | • | • | • | |
| 4W__ Lyris 2™ | | | | | | 18 | • | | | | | | | | | | |
| 3D__ Pellicle® Classic | 7 | | | | | | | | | | | | | | | | |
| 235__ Tailored [A] | | • | | | • | | | | | | | | | • | • | | |
| 92__ Crepe | | 14 | • | • | | | | | | • | • | • | • | • | • | • | |
| 22Q__ Fish Net | | • | • | • | • | | | | | | | | | | | • | |
| 3A__ Moiré | | 14 | • | • | • | • | • | • | • | • | • | | | • | | | |
| 30__ Rhythm | | 14 | 16 | 24 | • | | | | | | 8 | | | | | • | |
| 8R__ Twist | | 14 | • | • | • | • | • | • | • | • | 8 | | | • | • | • | |
| 70__ Bento | | | | • | • | • | • | • | 2 | • | | 8 | | | | • | |
| 8M__ Latitude™ | | • | • | • | | | | | | | | | | | | | |
| 22R__ Pins and Needles | | | • | • | • | | | | | | | | | | | | |
| 8U__ Stitches | | 14 | • | • | • | • | • | • | • | • | • | | | • | • | • | |
| 22V__ String Plaid | | | | • | | | | | | | | | | • | | | |
| 6J__ Plateau | | | | | | | | | | | | • | | | | | |
| 6S__ Quilty | | 14 | • | • | | | | | | | | | | | | • | |
| 14A__ Hopsak | | 14 | • | | | | • | | | • | • | • | | | | • | • |
| 35__ Balance | | | 17 | | | | | | | | | | | | | | |
| 21__ Leather | | 14 | | | | | | | | | | 8 | | | | | |

All foam and Proprietary Textiles on HermanMiller seating comply with California TB 117-2013.

Application Note: Herman Miller cannot guarantee material/pattern alignment in adjacent products. For example, a fabric's pattern may not align from one pedestal cushion top to the next, or from one chair to another.

- | | |
|--|--|
| 1 Refer to price book appendices and Omni for COM/COL information. | 16 Only available in 3014 Black. |
| 2 Available on all Ergon 3 chairs except for fabric back (FB) option. | 17 Only available in 3512 Carbon and 3513 Black. |
| 3 Available on A-and B-size Equa 2 split-pad upholstered chairs. | 18 Only available in 4W26 Slate Grey, 4W30 Java, and 4W31 Graphite. |
| 4 See specific products for information on specifying leather in combination with fabric. | 21 Not available on Sayl upholstered back work chairs. |
| 6 Only available in 3P02 Navy, 3P03 Spruce, 3P14 Black, 3P17 Burgundy, 3P19 Slate, and 3PC7 Bucksuede. | 22 Not available on Sayl side chairs with upholstered backs. |
| 7 Only available in 3D01 Graphite. | 23 Available in select colors. Refer to "Proprietary Textile Colors-Seating" for color offering. |
| 8 Only available on nonupholstered outer back option (PB). | 24 Not available on Sayl upholstered High-Back Work Chairs. |
| 14 Available on Celle UC (upholstered seat) and HC (upholstered seat with protective edge) Chairs. | |
| 15 Available only on Celle HC (upholstered seat with protective edge) Chairs. | |

Proprietary Textile Colors – Seating

Price Category 1

Customer's Own Material
See Order Information in
Appendices.
Assigned lead-time textile. A

8Z Pellicle®
For New Aeron® Chairs
56% elastomeric
44% polyester
23101 Mineral
23102 Carbon
23103 Graphite

AireWeave™ 2
For Mirra® 2 Chairs
67% elastomeric
33% antimony-free polyester
1A701 Alpine
1A702 Slate Grey
1A703 Graphite
1A704 Lime Green
1A705 Cappuccino
1A706 Urban Orange
1A707 Dark Turquoise
1A708 Twilight

ColorGuard
54" wide
100% vinyl
3P01 Grey
3P02 Navy *
3P03 Spruce * A
3P04 Jade A
3P05 Natural A
3P08 Blueberry A
3P09 Coal A
3P12 Black Plum A
3P14 Black *
3P15 New Burgundy A
3P17 Burgundy * A
3P19 Slate *
3P31 Horizon Blue A
3P33 Pumice
3P54 Candy Apple A
3P58 Beige A
3P66 Deep Clay A
3P72 Allspice A
3P90 Green Tea A
3P93 Camelback A
3P96 Manzanita A
3P97 Fudge A
3PB2 Sea Grass A
3PB5 Vizcaya Palm A
3PB9 Neptune A
3PC7 Bucksuede * A
3PD4 Otter A

* Colors available on Eames®
Tandem Sling Seating.

A Assigned lead-time color.

Crossing
54" wide
86% antimony-free polyester
14% polyester
8T03 Wicker
8T04 Porcelain
8T05 Warm Grey
8T06 Sepia
8T07 Pumpkin
8T08 Copper
8T09 Cranberry
8T10 Tomato
8T11 Mulberry
8T12 Plum
8T13 Green Apple
8T14 Loden
8T15 Spruce
8T16 Periwinkle
8T17 Cerulean
8T18 Indigo
8T19 Shale
8T20 Brownstone
8T21 Bark
8T22 Tin
8T23 Graphite
8T24 Black

Flexnet™
For Caper® Chairs
69% elastomeric
31% polyester
6V01 Black
6V02 Silver Grey

Gem
54" wide
100% antimony-free polyester
9501 Sesame
9502 Tangerine
9503 Red
9504 Red Violet
9505 Mulberry
9506 Java
9507 Twilight
9508 Bayou
9509 Iris
9510 Berry Blue
9511 Aqua Green
9512 Green Apple
9513 Spruce
9514 Black
9515 Slate Grey
9516 Fog

Interweave
For Verus™ Chairs
71% elastomeric
29% polyester
6504 Pewter
6505 Charcoal
6506 Black

Lyris 2™
For Setu® Chairs
74% elastomeric
26% polyester
4W21 Alpine
4W22 Mango
4W23 Chartreuse
4W25 Berry Blue
4W26 Slate Grey
4W28 Chino
4W29 Rattan
4W30 Java
4W31 Graphite

Category 1 continued on next
page

Proprietary Textile Colors – Seating

continued

Price Category 1

continued

Monologue

54" wide
56% recycled polyester
44% polyester

| | |
|-------|--------------|
| 1MN01 | Linen |
| 1MN02 | Alabaster |
| 1MN03 | Truffle |
| 1MN04 | Folkstone |
| 1MN05 | Silver Pine |
| 1MN06 | Slate |
| 1MN07 | Seed |
| 1MN08 | Yellow Oxide |
| 1MN09 | Persimmon |
| 1MN10 | Tundra |
| 1MN11 | Meadow |
| 1MN12 | Blue Sky |
| 1MN13 | Blue Spruce |
| 1MN14 | Deep Sea |

Pellicle® Classic

For Classic Aeron® chairs with a graphite or polished aluminum base.
70% elastomeric, 30% polyester

| | |
|------|--------|
| 3D01 | Carbon |
| 3D02 | Lead |

Pellicle Classic

For Classic Aeron chairs with a titanium base.
70% elastomeric
30% polyester

| | |
|------|--------|
| 3V01 | Zinc |
| 3V03 | Quartz |

Stretch Knit

Assigned lead-time textile. A
Available only on Sayl®
Suspension Back Work Chairs
97% polyester, 3% spandex

| | |
|-------|-------------|
| 3DK01 | Fog |
| 3DK02 | Slate Grey |
| 3DK03 | Java |
| 3DK04 | Black |
| 3DK05 | Red |
| 3DK06 | Green Apple |
| 3DK07 | Berry Blue |

Tailored

Assigned lead-time textile. A
54" wide
56% polyester
44% recycled polyester

| | |
|-------|--------------|
| 23501 | Studio White |
| 23502 | Sugar |
| 23503 | Tomato |
| 23504 | Orchid |
| 23505 | Boysenberry |
| 23506 | Chive |
| 23507 | Bluegrass |
| 23508 | Cobalt |
| 23509 | Cadet |
| 23510 | Fog |
| 23511 | Graphite |
| 23512 | Black |
| 23513 | Coffee |

Whisper

54" wide
73% recycled polyester
27% polyester

| | |
|-------|--------------|
| 1WS01 | Sand Dollar |
| 1WS02 | Pebble |
| 1WS03 | Silver Birch |
| 1WS04 | Iceberg |
| 1WS05 | Silver Pine |
| 1WS06 | Carbon |
| 1WS07 | Cumin |
| 1WS08 | Adobe |
| 1WS09 | Strawberry |
| 1WS10 | Blush |
| 1WS11 | Eggplant |
| 1WS12 | Willow |
| 1WS13 | Sea Grass |
| 1WS14 | Pool |
| 1WS15 | Blueberry |

Price Category 2

Crepe

54" wide
100% recycled polyester

| | |
|------|-------------|
| 9201 | Licorice |
| 9203 | Smoke |
| 9207 | Cherry |
| 9209 | Claret |
| 9212 | Raisin |
| 9218 | Aquamarine |
| 9223 | Cadet |
| 9241 | Beachglass |
| 9243 | Midnight |
| 9244 | Artichoke |
| 9248 | Warm White |
| 9249 | Stone |
| 9250 | Earth |
| 9251 | Fog |
| 9252 | Slate Grey |
| 9253 | Yellow Dark |
| 9254 | Coral |
| 9255 | Blush Grey |
| 9256 | Wild Berry |
| 9257 | Clover |
| 9258 | Caribbean |
| 9259 | Cerulean |
| 9260 | Brownstone |
| 9261 | Shale |
| 9262 | Graphite |
| 9263 | Tomato |
| 9264 | Green Apple |

Fish Net

55" wide
100% recycled polyester

| | |
|-------|-----------|
| 22Q01 | Oyster |
| 22Q02 | Stone |
| 22Q03 | Citrus |
| 22Q04 | Curry |
| 22Q05 | Chipotle |
| 22Q06 | Cherry |
| 22Q07 | Fuschia |
| 22Q08 | Claret |
| 22Q09 | Purple |
| 22Q10 | Clover |
| 22Q11 | Pesto |
| 22Q12 | Peacock |
| 22Q13 | Lagoon |
| 22Q14 | Twilight |
| 22Q15 | Bluestone |
| 22Q16 | Storm |
| 22Q17 | Black |
| 22Q18 | Cocoa |

Loom

54" wide
100% polyester

| | |
|-------|-----------------------|
| 1LM01 | Linen |
| 1LM02 | Brown Sugar and Spice |
| 1LM03 | Brick and Mortar |
| 1LM04 | Salt and Pepper |
| 1LM05 | Black |
| 1LM06 | Lemongrass |
| 1LM07 | Poppy |
| 1LM08 | Wild Berry |
| 1LM09 | Loden |
| 1LM10 | Jade |
| 1LM11 | Deep Sea |

Category 2 continued on next page

Proprietary Textile Colors – Seating

continued

Price Category 2

continued

| Marvel | |
|----------------------------|----------------|
| 54" wide | |
| 100% pvc-free polyurethane | |
| 1MV01 | Summer White |
| 1MV02 | Sand Dollar |
| 1MV03 | Espresso |
| 1MV04 | Folkstone Grey |
| 1MV05 | Graphite |
| 1MV06 | Onyx |
| 1MV07 | Polar Blue |
| 1MV08 | Blush Grey |
| 1MV09 | Woodrose |
| 1MV10 | Citrus |
| 1MV11 | Adobe |
| 1MV12 | Red |
| 1MV13 | Kiwi Green |
| 1MV14 | Pine |
| 1MV15 | Teal Green |
| 1MV16 | Twilight |

| Medley | |
|----------------|--------------|
| 54" wide | |
| 100% polyester | |
| 1HA01 | Stone |
| 1HA02 | Trail |
| 1HA03 | Charcoal |
| 1HA04 | Cinder |
| 1HA05 | Citrus |
| 1HA06 | Papaya |
| 1HA07 | Chutney |
| 1HA08 | Tundra |
| 1HA09 | Feather Grey |
| 1HA10 | Chartreuse |
| 1HA11 | Loden |
| 1HA12 | Peacock |
| 1HA13 | Bayou |
| 1HA14 | Blue Grotto |
| 1HA15 | Blueberry |
| 1HA22 | Khaki |
| 1HA23 | Pewter |
| 1HA24 | Yellow Oxide |
| 1HA25 | Vintage Rose |
| 1HA26 | Raspberry |
| 1HA27 | Acai Berry |

| Moiré | |
|-------------------------|----------|
| 54" wide | |
| 100% recycled polyester | |
| 3A01 | Concrete |
| 3A02 | Biscotti |
| 3A03 | Rattan |
| 3A04 | Chambray |
| 3A05 | Fern |
| 3A08 | Violet |
| 3A09 | Zin |
| 3A10 | Curry |
| 3A11 | Spice |
| 3A12 | Cork |

| Pellicle® Tuxedo | |
|--|------------|
| For Classic Aeron® chairs with a graphite or polished aluminum base. | |
| 64% elastomeric | |
| 36% polyester | |
| 4M01 | Grey Black |
| 4M02 | Blue Black |

| Pellicle Tuxedo | |
|--|------------|
| For Classic Aeron chairs with a titanium base. | |
| 64% elastomeric | |
| 36% polyester | |
| 4Q01 | White Gold |

| Pellicle Waves | |
|---|----------|
| For Classic Aeron chairs with a graphite or polished aluminum base. | |
| 68% elastomeric | |
| 32% polyester | |
| 4E01 | Carbon |
| 4E03 | Platinum |

| Pellicle Waves | |
|--|--------|
| For Classic Aeron chairs with a titanium base. | |
| 68% elastomeric | |
| 32% polyester | |
| 4F01 | Zinc |
| 4F03 | Quartz |

| Rhythm | |
|----------------|--------------|
| 54" wide | |
| 100% polyester | |
| 3001 | Kiwi Green * |
| 3002 | Green Apple |
| 3003 | Peacock |
| 3004 | Bayou * |
| 3005 | Berry Blue |
| 3006 | Iris |
| 3007 | Twilight |
| 3008 | Pumpkin * |
| 3009 | Poppy * |
| 3010 | Molasses |
| 3011 | Mulberry |
| 3012 | Khaki * |
| 3013 | Mink |
| 3014 | Black |
| 3015 | Charcoal |

* Colors not available on Embody® Chair.

| Rivet | |
|-------------------------|--------------|
| 54" wide | |
| 100% recycled polyester | |
| 1RV01 | Twig |
| 1RV02 | Deep Clay |
| 1RV03 | Woodrose |
| 1RV04 | Otter |
| 1RV05 | Hemlock |
| 1RV06 | Olive |
| 1RV07 | Lagoon |
| 1RV08 | Deep Sea |
| 1RV09 | Charcoal |
| 1RV10 | Grey Brindle |

| Twist | |
|-----------------------------|---------------|
| 54" wide | |
| 80% antimony-free polyester | |
| 13% recycled polyester | |
| 7% polyester | |
| 8R05 | Wicker |
| 8R10 | Poppy |
| 8R14 | Tin |
| 8R15 | Shale |
| 8R16 | Graphite |
| 8R17 | Birch |
| 8R18 | Sepia |
| 8R22 | Blueberry |
| 8R23 | Green Apple |
| 8R26 | Gunmetal |
| 8R27 | Cinder |
| 8R28 | Citrus |
| 8R29 | Pekoe |
| 8R30 | Tangerine |
| 8R31 | Red Plum |
| 8R32 | Wisteria |
| 8R33 | Forest |
| 8R34 | Jade Dark |
| 8R35 | Waterfall |
| 8R36 | Midnight Blue |
| 8R37 | Carbon Dark |

Category 2 continued on next page

Proprietary Textile Colors – Seating

continued

Price Category 2

continued

Well Suited

55" wide
79% polyester
21% recycled polyester

| | |
|-------|----------------|
| 22T01 | Oyster * |
| 22T02 | Raffia * |
| 22T03 | Peppermint * |
| 22T04 | Wild Berry * |
| 22T05 | Spring Green * |
| 22T06 | Mint * |
| 22T07 | Periwinkle * |
| 22T08 | Cool Grey * |
| 22T09 | Citrus * |
| 22T10 | Pumpkin |
| 22T11 | Red |
| 22T12 | Fuschia |
| 22T13 | Orchid |
| 22T14 | Chartreuse * |
| 22T15 | Green Apple |
| 22T16 | Jade |
| 22T17 | Peacock |
| 22T18 | Blueberry |
| 22T19 | Bluestone * |
| 22T20 | Mink |

* Colors not available on Swoop™ Plywood Lounge Seating.

Price Category 3

Bento

54" wide
100% antimony-free polyester

| | |
|------|------------|
| 7001 | Frost |
| 7002 | Linen |
| 7003 | Khaki |
| 7004 | Truffle |
| 7005 | Grey Black |
| 7006 | Pumpkin |
| 7007 | Cranberry |
| 7008 | Everglade |
| 7009 | Cobalt |

Latitude™

61" wide
100% polyester

| | |
|------|----------------|
| 8M01 | Graphite |
| 8M02 | Shadow |
| 8M03 | Citron |
| 8M05 | Blue Fog |
| 8M06 | Cappuccino |
| 8M10 | Alpine |
| 8M15 | Champagne |
| 8M16 | Chestnut |
| 8M17 | Black |
| 8M18 | Brownstone |
| 8M21 | Slate Grey |
| 8M22 | Lime Green |
| 8M23 | French Press |
| 8M24 | Urban Orange |
| 8M25 | Dark Turquoise |
| 8M26 | Twilight |

Latitude

Colors for Mirra 2 Chairs
100% polyester

| | |
|------|----------------|
| 8M10 | Alpine |
| 8M17 | Black |
| 8M21 | Slate Grey |
| 8M22 | Lime Green |
| 8M23 | French Press |
| 8M24 | Urban Orange |
| 8M25 | Dark Turquoise |
| 8M26 | Twilight |

Pins and Needles

58" wide
76% recycled polyester
24% polyester

| | |
|-------|---------------|
| 22R01 | Day and Night |
| 22R02 | Night and Day |

Stitches

54" wide
54% polyester
46% recycled polyester

| | |
|------|--------------|
| 8U02 | Rye |
| 8U03 | Khaki |
| 8U04 | Honey |
| 8U05 | Cattail |
| 8U06 | Pumpkin |
| 8U07 | Brick |
| 8U08 | Cool Grey |
| 8U09 | Slate Blue |
| 8U10 | Juniper |
| 8U11 | Evening Blue |
| 8U12 | Charcoal |
| 8U13 | Kiwi Green |
| 8U14 | Olive |
| 8U15 | Pesto |
| 8U16 | Cocoa |
| 8U17 | Seed |

String Plaid

54" wide
100% recycled polyester

| | |
|-------|-----------------------|
| 22V01 | Warm White on Khaki |
| 22V02 | Mint on Yellow Green |
| 22V03 | Mist on Blue Grey |
| 22V04 | Sky Blue on Red |
| 22V05 | Lime on Magenta |
| 22V06 | Bright Green on Green |
| 22V07 | Aqua Blue on Cerulean |
| 22V08 | Ivory on Black |

Price Category 4

Bingo

54" wide
100% PVC-free polyurethane
Resilience® finish

| | |
|------|--------------|
| 7Y01 | Oyster |
| 7Y02 | Natural |
| 7Y03 | Cashew |
| 7Y04 | Buff |
| 7Y05 | Rattan |
| 7Y06 | Root |
| 7Y07 | Woodland |
| 7Y08 | Camel |
| 7Y09 | Copper |
| 7Y10 | Allspice |
| 7Y11 | Canyon |
| 7Y12 | Henna |
| 7Y13 | Sedona |
| 7Y14 | Black Plum |
| 7Y15 | Currant |
| 7Y16 | Mahogany |
| 7Y17 | Seed |
| 7Y18 | Mushroom |
| 7Y19 | Blue Grey |
| 7Y20 | Navy |
| 7Y21 | Black |
| 7Y22 | Mint |
| 7Y23 | Seaport |
| 7Y24 | Evening Blue |
| 7Y25 | Hemlock |
| 7Y26 | Kiwi Green |
| 7Y27 | Celadon |
| 7Y28 | Moss |
| 7Y29 | Pesto |

Category 4 continued on next page

Proprietary Textile Colors – Seating

continued

Price Category 4

continued

| Dialogue | |
|--|---------------|
| For Public Office Landscape® Sectional Back/Social Chair Back knit to size 100% polyester | |
| 1DL01 | Light Brindle |
| 1DL02 | Dark Brindle |

| Mercer | |
|--|-------------|
| 54" wide 50% solution dyed recycled nylon 50% solution dyed nylon BLOCKaide | |
| 21301 | Stone |
| 21302 | Rattan |
| 21303 | Cayenne |
| 21304 | Chutney |
| 21305 | Pesto |
| 21306 | Teal Blue |
| 21307 | Ultramarine |
| 21308 | Acai Berry |
| 21309 | Ash Brown |
| 21310 | Charcoal |

| Network | |
|--|-------------|
| For Public Office Landscape® Sectional Back/Social Chair Back knit to size 100% polyester | |
| 1A901 | Warm White |
| 1A902 | Fog |
| 1A903 | Red |
| 1A904 | Wildberry |
| 1A905 | Green Apple |
| 1A906 | Twilight |
| 1A907 | Graphite |

| Plateau Perspectives® Collection | |
|----------------------------------|--------------|
| knit to size 100% polyester | |
| 6J01 | Feather Grey |
| 6J02 | Trail |
| 6J03 | Mustard Seed |
| 6J04 | Fennel |
| 6J05 | Red Pepper |
| 6J06 | Twig |
| 6J07 | Waterfall |
| 6J08 | Sagebrush |
| 6J09 | Winter Berry |
| 6J10 | Thunder |
| 6J11 | Blueberry |
| 6J12 | Rosemary |
| 6J13 | Wild Plum |
| 6J14 | Black |

| Quilty | |
|---|-------------|
| 56" wide 100% antimony-free polyester GreenShield | |
| 6S03 | Khaki |
| 6S04 | Straw |
| 6S07 | Brick |
| 6S10 | Mink |
| 6S11 | Green Apple |
| 6S13 | Indigo |
| 6S14 | Zinc |
| 6S15 | Slate |
| 6S16 | Beachwood |
| 6S17 | Paprika |
| 6S18 | Plum |
| 6S19 | Juniper |
| 6S20 | Grey Black |

| Spools | |
|---|------------|
| 54" wide 51% recycled polyester 49% polyester Crypton® Green | |
| 8Y01 | Cashew |
| 8Y02 | Wicker |
| 8Y03 | Trail |
| 8Y04 | Cappuccino |
| 8Y05 | Copper |
| 8Y08 | Bluegrass |
| 8Y09 | Lagoon |
| 8Y10 | Grape |
| 8Y11 | Beachglass |
| 8Y12 | Marsh |
| 8Y13 | Bud |

| Strata | |
|--|---------------|
| 54" wide 50% solution dyed recycled nylon 50% solution dyed nylon BLOCKaide | |
| 22P01 | Rattan |
| 22P02 | Yellow Jacket |
| 22P03 | Avocado |
| 22P04 | Pesto |
| 22P05 | Peacock |
| 22P06 | Blue Jay |
| 22P07 | Blueberry |
| 22P08 | Boysenberry |
| 22P09 | Mango |
| 22P10 | Paprika |
| 22P12 | Wheat |
| 22P13 | Brownstone |
| 22P14 | Bayou |
| 22P15 | Trail |

Price Category 5

| Hopsak | |
|-------------------------------------|-------------------|
| 56" wide 100% recycled polyester | |
| 14A20 | Black |
| 14A22 | Raw Umber Dark |
| 14A26 | Grey Blue Dark |
| 14A30 | Sepia Dark |
| 14A38 | Emerald Dark |
| 14A39 | Yellow Dark |
| 14A40 | Orange |
| 14A41 | Sienna |
| 14A42 | Olive Green Dark |
| 14A43 | Crimson |
| 14A44 | Crimson Dark Dark |
| 14A45 | Violet Dark |
| 14A46 | Pink Dark Dark |
| 14A47 | Ultramarine Dark |
| 14A48 | Cobalt Blue |
| 14A49 | Terra Cotta |
| 14A50 | Ochre Dark |

| Noble | |
|--|----------------------|
| Assigned lead-time textile. <input type="checkbox"/> A | |
| 54" wide 100% wool | |
| 22N02 | Chipotle * |
| 22N04 | Cherry * |
| 22N07 | Cadet * |
| 22N08 | Berry Blue * |
| 22N09 | Peacock * |
| 22N11 | Pesto * |
| 22N12 | Blue Grey Mix * |
| 22H15 | Heathered Black |
| 22H16 | Heathered Grey |
| 22H17 | Heathered Twilight |
| 22H18 | Heathered Rye Grass |
| 22N19 | Lemongrass Mix * |
| 22H20 | Heathered Red |
| 22H21 | Heathered Wild Berry |
| 22N22 | Pesto Mix * |
| 22N23 | Lagoon Mix * |

* Colors not available on Sayl® Side Chairs.

Proprietary Textile Colors – Seating

continued

Appendix: Proprietary Textile Colors – Seating

Price Category 6

Balance

For Embody® chairs

100% polyester

3506 Green Apple

3507 Blue Moon

3509 Berry Blue

3510 Iris

3512 Carbon

3513 Black

Price Category 7

Customer's Own Leather

See Order Information in
Appendices. Assigned lead-time
textile. A

Price Category 8

No fabrics available at this time.

Price Category 9

Leather

approx. 50 sq. ft. per hide

100% leather

2101 Ivory

2109 Black

2110 Smoke

2111 Graphite

2112 Khaki

2113 Rattan

2114 Truffle

2115 Alpine

2116 Haze

2117 Sable Grey

2118 Dark Mineral

2119 Dark Carbon

2120 Cranberry

2121 Deep Sea

Maharam® Application Chart – Seating

- Available

See below for exception notes.

Maharam textiles are on assigned lead times. A

[N] Non-woven textile.

| | Classic Aeron® Work Chairs/Stools | Classic Aeron Arm pads/Arm Kit | Mirra® Chairs/Stools | Celle® Chairs | Sayl® Work Chairs/Stools | Sayl Side Chairs | Setu® Chairs/Stools | Setu Lounge Chair/Ottoman | Verus™ Work Chairs/Stools Seat | Verus Side Chairs Seat | Ergon 3® Chairs | Ergon 3 Adjustable Arm Kit | Equa 2® Fully Upholstered Chairs/Stools | Equa 2 Split-Pad Upholstered Chairs/Stools | Equa 2 Adjustable Arm Kit | Aside® Chairs | Caper® Chairs/Stools | Celeste™ Seating | Keyn Chair Group | Locale® Bench Cushions | Public Office Landscape® Seat | Plex™ Lounge Furniture | Swoop™ Lounge Seating - Fully Upholstered | Swoop Lounge Seating - Plywood | Cushion Tops | Workspaces |
|------------------------------------|-----------------------------------|--------------------------------|----------------------|---------------|--------------------------|------------------|---------------------|---------------------------|--------------------------------|------------------------|-----------------|----------------------------|---|--|---------------------------|---------------|----------------------|------------------|------------------|------------------------|-------------------------------|------------------------|---|--------------------------------|--------------|------------|
| Price Category A | | | | | | | | | | | | | | | | | | | | | | | | | | |
| No fabrics available at this time. | | | | | | | | | | | | | | | | | | | | | | | | | | |
| Price Category B | | | | | | | | | | | | | | | | | | | | | | | | | | |
| VM__ Medium - Maharam | | | | 14 | • | • | | | • | • | • | | • | 3 | | • | • | • | | | | • | • | • | • | • |
| TI__ Messenger - Maharam * | | | 14 | • | • | • | • | • | • | • | | | | • | | • | • | • | | | | • | • | • | • | • |
| Price Category C | | | | | | | | | | | | | | | | | | | | | | | | | | |
| No fabrics available at this time. | | | | | | | | | | | | | | | | | | | | | | | | | | |
| Price Category D | | | | | | | | | | | | | | | | | | | | | | | | | | |
| Z27__ Manner - Maharam | | | 14 | • | • | | | • | • | • | | | • | • | | • | • | • | | | | • | • | • | • | • |
| Price Category E | | | | | | | | | | | | | | | | | | | | | | | | | | |
| ZFS__ Focus - Maharam | | | 14 | 16 | 16 | | | | | | | | | | | • | | | • | | | | | | | • |
| ZLR__ Lariat - Maharam [N] | | | 14 | 16 | 16 | | | • | • | | | | | | | | | | • | | • | | | | | • |
| VgG__ Ledger - Maharam [N] | | | 14 | 16 | 16 | | | • | • | | | | | | | | | | • | | | | | | | • |
| Z3__ Metric - Maharam | | | 14 | • | • | | | • | • | • | | | • | • | | • | • | • | | | | • | • | • | • | • |
| ZMD__ Mode - Maharam | | | 14 | • | • | | | • | • | | | | • | | | • | • | • | | | | • | • | • | • | • |
| ZBQ__ Oblique - Maharam | | | | | 16 | | | | | | • | | | | | • | | | • | | | | • | • | • | • |
| ZP2__ Pick - Maharam | | | | | • | • | | | | | • | | | | | • | | | • | | | | • | • | • | • |
| Z32__ Skein - Maharam | | | 14 | 16 | 16 | • | | | | | | | | | | • | | | • | | | | • | • | | • |
| ZT3__ Technic - Maharam | | | 14 | 18 | 16 | | | | | | | | | | | • | | | • | | | | | | | |
| Price Category F | | | | | | | | | | | | | | | | | | | | | | | | | | |
| ZCH__ Chock - Maharam | | | | | | | | | | | | | | | | • | | | | | | | | | | |
| ZC8__ Coin - Maharam | | | 14 | 18 | 16 | | | | | | | | | | | • | | | • | | | | | | | • |
| ZCJ__ Coincide - Maharam | | | | 16 | 16 | | | | | | | | | | | • | | | • | | | | | | | • |
| VS__ Crush - Maharam | | | | | | | | • | • | | | | | | | | | • | | | | • | | | | • |
| ZD1__ Disc - Maharam | | | 14 | 18 | 16 | | | | | | | | | | | • | | | • | | | | | | | • |
| ZD3__ Divide - Maharam | | | 14 | 18 | 16 | | | | | | | | | | | • | | | • | | | | | | | • |
| ZEE__ Exchange - Maharam | | | 14 | 16 | 16 | | | • | • | | | | | | | • | | | • | | | • | | | | • |
| Z29__ Plait - Maharam | | | 14 | 16 | 16 | • | | | | | | | | | | • | | | • | | | | • | | | • |
| V26__ Remix - Maharam | | | | 16 | 16 | | | | | | | | | | | | | • | • | | | • | | | | • |
| ZRV__ Rove - Maharam | | | 14 | 16 | 16 | | | | | | | | | | | | | | • | | | | | | | |
| ZRA__ Runner Standard - Maharam | | | 14 | 16 | 16 | | | | | | | | | | | | | | • | | | | | | | |
| ZSM__ Seam - Maharam | | | 14 | 18 | 16 | | | | | | | | | | | • | | | • | | | | | | | |
| Z31__ Sequence - Maharam | | | 14 | 16 | • | | | | | | | | • | | • | | | • | • | | | • | | | | • |
| ZSS__ Shuttle Standard - Maharam | | | 14 | 16 | 16 | | | | | | | | | | | | | | • | | | | | | | |
| Z33__ Strum - Maharam [N] | | | | | 16 | | | | | | | | | | | | | • | • | | | • | | | | |
| ZWX__ Waxen - Maharam | | | 14 | 16 | 16 | | | | | | | | | | | | | • | | | | | | | | |

* Available in select colors on 20-day lead-time.
Refer to "Maharam Colors - Seating" for 20-day colors.

continued on next page

Maharam® Colors – Seating

Price Category A

No fabrics available at this time.

Price Category B

Medium – Maharam

| |
|----------------------------|
| 54" wide |
| 100% polyester |
| VM01/463490-001 Raven |
| VM02/463490-002 Smoke |
| VM03/463490-003 Alloy |
| VM04/463490-004 Flax |
| VM06/463490-006 Bark |
| VM07/463490-007 Espresso |
| VM08/463490-008 Pecan |
| VM12/463490-012 Pumpkin |
| VM13/463490-013 Persimmon |
| VM14/463490-014 Laser |
| VM16/463490-016 Port |
| VM22/463490-022 Marina |
| VM29/463490-029 Pistachio |
| VM32/463490-032 Prospect |
| VM36/463490-036 Delight |
| VM39/463490-039 Nautical |
| VM40/463490-040 Pool |
| VM44/463490-044 Washed |
| VM45/463490-045 Sculpture |
| VM46/463490-046 Thatched |
| VM47/463490-047 Hike |
| VM48/463490-048 Tangle |
| VM49/463490-049 Pacific |
| VM50/463490-050 Cosmic |
| VM51/463490-051 Cascade |
| VM52/463490-052 Blackberry |
| VM53/463490-053 Nasturtium |
| VM54/463490-054 Wooded |

Messenger – Maharam

| |
|-----------------------------|
| 54" wide |
| 78% recycled polyester |
| 15% polyester, 7% nylon |
| TI01/458640-001 Balsa |
| TI06/458640-006 Tobacco |
| TI07/458640-007 Shadow * |
| TI08/458640-008 Bayou * |
| TI10/458640-010 Zinc |
| TI24/458640-024 Poppy |
| TI25/458640-025 Mao |
| TI29/458640-029 Onyx |
| TI31/458640-031 Cloud * |
| TI38/458640-038 Depth * |
| TI40/458640-040 Nile |
| TI41/458640-041 Azure * |
| TI45/458640-045 Cactus * |
| TI46/458640-046 Ice * |
| TI48/458640-048 Neon * |
| TI50/458640-050 Hydrangea * |
| TI51/458640-051 Lilac |
| TI52/458640-052 Chestnut |
| TI53/458640-053 Tangelo |
| TI54/458640-054 Lumine * |
| TI58/458640-058 Snow |
| TI59/458640-059 Fennel |
| TI60/458640-060 Peridot * |
| TI61/458640-061 Capri |
| TI62/458640-062 Ultramarine |
| TI63/458640-063 Squall |
| TI66/458640-066 Cassis |
| TI67/458640-067 Aster |
| TI68/458640-068 Spice |
| TI69/458640-069 Cherry |
| TI70/458640-070 Vibrant |
| TI71/458640-071 Satsuma * |
| TI72/458640-072 Maize |

* Colors available on 20-day lead time.

Messenger continued

| |
|---------------------------|
| TI76/458640-076 Fossil |
| TI77/458640-077 Ash |
| TI78/458640-078 Tusk |
| TI79/458640-079 Oyster |
| TI80/458640-080 Pensive |
| TI81/458640-081 Husk |
| TI82/458640-082 Fireside |
| TI83/458640-083 Chili |
| TI84/458640-084 Robust |
| TI85/458640-085 Beyond |
| TI86/458640-086 Voyage |
| TI87/458640-087 Everglade |
| TI88/458640-088 Electric |

- Maharam textiles are on assigned lead times A unless otherwise noted.
- Fabric numbers are listed as Herman Miller fabric number/Maharam fabric number.

Maharam® Colors – Seating

continued

Price Category C

No fabrics available at this time.

Price Category D

Manner - Maharam

| | |
|-------------------------|--------------|
| 54" wide | |
| 100% recycled polyester | |
| Z2701/466177-001 | Magic |
| Z2702/466177-002 | Carob |
| Z2703/466177-003 | Porpoise |
| Z2704/466177-004 | Flint |
| Z2705/466177-005 | Hush |
| Z2706/466177-006 | Nuance |
| Z2707/466177-007 | Thicket |
| Z2708/466177-008 | Cocoa |
| Z2709/466177-009 | Pathway |
| Z2710/466177-010 | Cola |
| Z2711/466177-011 | Ember |
| Z2712/466177-012 | Wagon |
| Z2713/466177-013 | Ablaze |
| Z2714/466177-014 | Peel |
| Z2715/466177-015 | Penny |
| Z2716/466177-016 | Butterscotch |
| Z2717/466177-017 | Harvest |
| Z2718/466177-018 | Lioness |
| Z2719/466177-019 | Caper |
| Z2720/466177-020 | Parakeet |
| Z2721/466177-021 | Greenway |
| Z2722/466177-022 | Aquatic |
| Z2723/466177-023 | Cottage |
| Z2724/466177-024 | Dahlia |
| Z2725/466177-025 | Vivid |
| Z2726/466177-026 | Basin |
| Z2727/466177-027 | Schooner |

Price Category E

Focus - Maharam

| | |
|--|---------|
| 57" wide | |
| 54% post-industrial recycled polyester | |
| 33% polyester | |
| 13% post-consumer recycled polyester | |
| ZFS01/465910-001 | Ivory |
| ZFS02/465910-002 | Allow |
| ZFS04/465910-004 | Lichen |
| ZFS06/465910-006 | Sierra |
| ZFS07/465910-007 | Merlot |
| ZFS08/465910-008 | Clove |
| ZFS09/465910-009 | Carbon |
| ZFS10/465910-010 | Regatta |
| ZFS11/465910-011 | Emerald |

Lariat – Maharam

| | |
|------------------|-----|
| 54" wide | |
| 100% vinyl | |
| ZLR01/440401-001 | 001 |
| ZLR02/440401-002 | 002 |
| ZLR03/440401-003 | 003 |
| ZLR04/440401-004 | 004 |
| ZLR06/440401-006 | 006 |
| ZLR07/440401-007 | 007 |
| ZLR08/440401-008 | 008 |
| ZLR10/440401-010 | 010 |
| ZLR11/440401-011 | 011 |
| ZLR12/440401-012 | 012 |
| ZLR13/440401-013 | 013 |
| ZLR14/440401-014 | 014 |
| ZLR15/440401-015 | 015 |
| ZLR16/440401-016 | 016 |
| ZLR18/440401-018 | 018 |
| ZLR20/440401-020 | 020 |
| ZLR21/440401-021 | 021 |
| ZLR23/440401-023 | 023 |
| ZLR24/440401-024 | 024 |
| ZLR25/440401-025 | 025 |
| ZLR26/440401-026 | 026 |
| ZLR27/440401-027 | 027 |
| ZLR28/440401-028 | 028 |
| ZLR29/440401-029 | 029 |
| ZLR30/440401-030 | 030 |
| ZLR31/440401-031 | 031 |
| ZLR32/440401-032 | 032 |
| ZLR33/440401-033 | 033 |
| ZLR34/440401-034 | 034 |
| ZLR35/440401-035 | 035 |
| ZLR36/440401-036 | 036 |
| ZLR37/440401-037 | 037 |
| ZLR38/440401-038 | 038 |

Price category E continued on next page

- Maharam textiles are on assigned lead times **A** unless otherwise noted.
- Fabric numbers are listed as Herman Miller fabric number/Maharam fabric number.

Maharam® Colors – Seating

continued

Price Category E

continued

Ledger – Maharam

| | |
|-------------------|-----|
| 54" wide | |
| 100% polyurethane | |
| V9G1/463770-001 | 001 |
| V9G2/463770-002 | 002 |
| V9G3/463770-003 | 003 |
| V9G4/463770-004 | 004 |
| V9G6/463770-006 | 006 |
| V9G7/463770-007 | 007 |
| V9GG/463770-017 | 017 |
| V9GH/463770-018 | 018 |
| V9GJ/463770-019 | 019 |
| V9GK/463770-020 | 020 |
| V9GM/463770-022 | 022 |
| V9GQ/463770-025 | 025 |
| V9GS/463770-026 | 026 |
| V9GT/463770-027 | 027 |
| V9GU/463770-028 | 028 |
| V9GV/463770-029 | 029 |
| V9GW/463770-030 | 030 |
| V9GX/463770-031 | 031 |
| V9GY/463770-032 | 032 |
| V9GZ/463770-033 | 033 |
| V9G10/463770-034 | 034 |
| V9G11/463770-035 | 035 |
| V9G12/463770-036 | 036 |
| V9G13/463770-037 | 037 |
| V9G14/463770-038 | 038 |
| V9G15/463770-039 | 039 |
| V9G16/463770-040 | 040 |
| V9G17/463770-041 | 041 |
| V9G18/463770-042 | 042 |
| V9G19/463770-043 | 043 |
| V9G20/463770-044 | 044 |
| V9G21/463770-045 | 045 |
| V9G22/463770-046 | 046 |

Metric – Maharam

| | |
|------------------------|-------------|
| 54" wide | |
| 51% recycled polyester | |
| 49% polyester | |
| Z301/466014-001 | Phantom |
| Z302/466014-002 | Fog |
| Z303/466014-003 | Fleece |
| Z304/466014-004 | Sourdough |
| Z305/466014-005 | Toffee |
| Z306/466014-006 | Driftwood |
| Z307/466014-007 | Mineral |
| Z308/466014-008 | Bittersweet |
| Z309/466014-009 | Arabica |
| Z310/466014-010 | Cerise |
| Z311/466014-011 | Brick |
| Z312/466014-012 | Cardinal |
| Z313/466014-013 | Lava |
| Z314/466014-014 | Oriole |
| Z315/466014-015 | Cedar |
| Z317/466014-017 | Caramel |
| Z318/466014-018 | Pollen |
| Z319/466014-019 | Tupelo |
| Z320/466014-020 | Alligator |
| Z321/466014-021 | Envy |
| Z322/466014-022 | Bonsai |
| Z323/466014-023 | Tar |
| Z324/466014-024 | Anchor |
| Z325/466014-025 | Twilight |
| Z326/466014-026 | Admiral |
| Z327/466014-027 | Seaport |
| Z328/466014-028 | Scuba |

Mode – Maharam

| | |
|--------------------------------------|------------|
| 54" wide | |
| 80% post-consumer recycled polyester | |
| 20% polyester | |
| PFOA-Free stain resistant finish | |
| ZMD01/466337-001 | Stroll |
| ZMD02/466337-002 | Intaglio |
| ZMD03/466337-003 | Ominous |
| ZMD04/466337-004 | Machine |
| ZMD05/466337-005 | Talus |
| ZMD06/466337-006 | Marsh |
| ZMD07/466337-007 | Hollow |
| ZMD08/466337-008 | Sycamore |
| ZMD09/466337-009 | Clavicle |
| ZMD10/466337-010 | Billygoat |
| ZMD11/466337-011 | Spindle |
| ZMD12/466337-012 | Lemon |
| ZMD13/466337-013 | Oxeye |
| ZMD14/466337-014 | Henge |
| ZMD15/466337-015 | Goldenrod |
| ZMD16/466337-016 | Cottontail |
| ZMD17/466337-017 | Lioness |
| ZMD18/466337-018 | Oriole |
| ZMD19/466337-019 | Rust |
| ZMD20/466337-020 | Carotene |
| ZMD21/466337-021 | Blush |
| ZMD22/466337-022 | Vermillion |
| ZMD23/466337-023 | Alder |
| ZMD24/466337-024 | Kermes |
| ZMD25/466337-025 | Barberry |
| ZMD26/466337-026 | Petal |
| ZMD27/466337-027 | Valley |
| ZMD28/466337-028 | Odyssey |
| ZMD29/466337-029 | Ballpoint |
| ZMD30/466337-030 | Toile |
| ZMD31/466337-031 | Paradise |
| ZMD32/466337-032 | Angelfish |
| ZMD33/466337-033 | Denim |
| ZMD34/466337-034 | Crush |
| ZMD35/466337-035 | Jetty |
| ZMD36/466337-036 | Saltwater |
| ZMD37/466337-037 | Mallard |
| ZMD38/466337-038 | Celtic |

Mode continued

| | |
|------------------|------------|
| ZMD39/466337-039 | Eucalyptus |
| ZMD40/466337-040 | Bonsai |
| ZMD41/466337-041 | Sassafras |
| ZMD42/466337-042 | Yucca |
| ZMD43/466337-043 | Lichen |

Oblique - Maharam

| | |
|-----------------------------|-----|
| 58" wide | |
| 100% polyester | |
| with stain resistant finish | |
| ZBQ01/466222-001 | 001 |
| ZBQ02/466222-002 | 002 |
| ZBQ03/466222-003 | 003 |
| ZBQ04/466222-004 | 004 |
| ZBQ05/466222-005 | 005 |
| ZBQ06/466222-006 | 006 |
| ZBQ07/466222-007 | 007 |

Pick - Maharam

| | |
|-----------------------------|-----|
| 58" wide | |
| 100% polyester | |
| with stain resistant finish | |
| ZP201/466224-001 | 001 |
| ZP202/466224-002 | 002 |
| ZP203/466224-003 | 003 |
| ZP204/466224-004 | 004 |
| ZP205/466224-005 | 005 |
| ZP206/466224-006 | 006 |
| ZP207/466224-007 | 007 |
| ZP208/466224-008 | 008 |
| ZP209/466224-009 | 009 |
| ZP210/466224-010 | 010 |

Price category E continued on next page

Appendix: Maharam Colors – Seating

- Maharam textiles are on assigned lead times A unless otherwise noted.
- Fabric numbers are listed as Herman Miller fabric number/Maharam fabric number.

Maharam® Colors – Seating

continued

Appendix: Maharam Colors – Seating

Price Category E

continued

| Skein - Maharam | |
|------------------------|-------------|
| 54" wide | |
| 56% recycled polyester | |
| 44% polyester | |
| Z3201/466170-001 | Burrow |
| Z3204/466170-004 | Sumac |
| Z3205/466170-005 | Pomegranate |
| Z3206/466170-006 | Cavern |
| Z3207/466170-007 | Bitter |
| Z3208/466170-008 | Cinder |
| Z3209/466170-009 | Dock |
| Z3210/466170-010 | Cadet |
| Z3211/466170-011 | Marsh |

| Technic - Maharam | |
|--|-----------|
| 56" wide | |
| 60% post-industrial recycled polyester | |
| 40% post-consumer recycled polyester | |
| PFOA-Free stain resistant finish | |
| Acrylic backing | |
| ZT301/466226-001 | Cumin |
| ZT302/466226-002 | Evergreen |
| ZT303/466226-003 | Cobalt |
| ZT304/466226-004 | Bear |
| ZT305/466226-005 | Squirrel |

Price Category F

| Chock - Maharam | |
|--|--------|
| 59" wide | |
| 36% rayon | |
| 35% cotton | |
| 29% solution-dyed post-industrial recycled nylon | |
| PFOA-Free stain resistant finish | |
| Acrylic backing | |
| ZCH01/466219-001 | Beige |
| ZCH02/466219-002 | Stone |
| ZCH03/466219-003 | Brown |
| ZCH04/466219-004 | Red |
| ZCH05/466219-005 | Copper |
| ZCH06/466219-006 | Lime |
| ZCH07/466219-007 | Smoke |
| ZCH08/466219-008 | Ebony |

| Coin - Maharam | |
|--|----------|
| 57" wide | |
| 43% polyester | |
| 37% post-industrial recycled polyester | |
| 20% post-consumer recycled polyester | |
| PFOA-Free stain resistant finish | |
| Acrylic backing | |
| ZC801/466233-001 | Nickel |
| ZC802/466233-002 | Diner |
| ZC803/466233-003 | Copper |
| ZC804/466233-004 | Maroon |
| ZC805/466233-005 | Penny |
| ZC806/466233-006 | Exchange |
| ZC807/466233-007 | Lead |

| Coincide - Maharam | |
|--------------------|-----------|
| 54" wide | |
| 100% polyester | |
| ZCJ01/465808-001 | Mist |
| ZCJ02/465808-002 | Drizzle |
| ZCJ03/465808-003 | Cicada |
| ZCJ04/465808-004 | Bungalow |
| ZCJ05/465808-005 | Aurora |
| ZCJ06/465808-006 | Currant |
| ZCJ07/465808-007 | Raisin |
| ZCJ08/465808-008 | Tranquil |
| ZCJ09/465808-009 | Caribbean |
| ZCJ10/465808-010 | Woodland |
| ZCJ11/465808-011 | Acre |

| Crush - Maharam | |
|-------------------------|-----|
| 54" wide | |
| 85% solution-dyed nylon | |
| 13% polyester | |
| 2% polyolefin | |
| VS01/464780-001 | 001 |
| VS02/464780-002 | 002 |
| VS05/464780-005 | 005 |
| VS08/464780-008 | 008 |
| VS13/464780-013 | 013 |
| VS16/464780-016 | 016 |
| VS17/464780-017 | 017 |
| VS18/464780-018 | 018 |
| VS19/464780-019 | 019 |
| VS20/464780-020 | 020 |
| VS22/464780-022 | 022 |
| VS23/464780-023 | 023 |
| VS24/464780-024 | 024 |
| VS25/464780-025 | 025 |
| VS26/464780-026 | 026 |
| VS27/464780-027 | 027 |

| Disc - Maharam | |
|----------------------------------|---------|
| 57" wide | |
| 100% polyester | |
| PFOA-Free stain resistant finish | |
| Acrylic backing | |
| ZD101/466221-001 | Nude |
| ZD102/466221-002 | Khaki |
| ZD103/466221-003 | Festive |
| ZD104/466221-004 | Vibrant |
| ZD105/466221-005 | Somber |
| ZD106/466221-006 | Warm |
| ZD107/466221-007 | Steel |

| Divide - Maharam | |
|--|----------|
| 57" wide | |
| 45% polyester | |
| 36% post-industrial recycled polyester | |
| 19% post-consumer recycled polyester | |
| PFOA-Free stain resistant finish | |
| Acrylic backing | |
| ZD301/466220-001 | Ecru |
| ZD302/466220-002 | Café |
| ZD303/466220-003 | Concrete |
| ZD304/466220-004 | Forest |
| ZD305/466220-005 | Tropic |
| ZD306/466220-006 | Lagoon |
| ZD307/466220-007 | Mocha |
| ZD308/466220-008 | Singe |
| ZD309/466220-009 | Cayenne |

| Exchange - Maharam | |
|--|-----------|
| 58" wide | |
| 58% post-industrial recycled polyester | |
| 42% post-consumer recycled polyester | |
| ZEE01/466027-001 | Cinder |
| ZEE02/466027-002 | Sable |
| ZEE04/466027-004 | Gull |
| ZEE06/466027-006 | Coastline |
| ZEE07/466027-007 | Clay |
| ZEE08/466027-008 | Buck |
| ZEE10/466027-010 | Rhubarb |
| ZEE11/466027-011 | Punch |

Price category F continued on next page

- Maharam textiles are on assigned lead times A unless otherwise noted.
- Fabric numbers are listed as Herman Miller fabric number/Maharam fabric number.

Maharam® Colors – Seating

continued

Price Category F

continued

Plait - Maharam

| | |
|------------------------|-------------|
| 58" wide | |
| 68% recycled polyester | |
| 32% polyester | |
| Z2901/466052-001 | Cobblestone |
| Z2902/466052-002 | Sachet |
| Z2903/466052-003 | Mesa |
| Z2904/466052-004 | Tavern |
| Z2905/466052-005 | Sequoia |
| Z2906/466052-006 | Rhubarb |
| Z2907/466052-007 | Sangria |
| Z2908/466052-008 | Reef |
| Z2909/466052-009 | Stormy |
| Z2910/466052-010 | Dapper |

Remix - Maharam

| | |
|------------------|-----|
| 54" wide | |
| 90% wool | |
| 10% nylon | |
| V2601/465956-113 | 113 |
| V2602/465956-123 | 123 |
| V2603/465956-133 | 133 |
| V2604/465956-143 | 143 |
| V2605/465956-152 | 152 |
| V2606/465956-163 | 163 |
| V2607/465956-173 | 173 |
| V2608/465956-183 | 183 |
| V2609/465956-223 | 223 |
| V2610/465956-233 | 233 |
| V2611/465956-242 | 242 |
| V2612/465956-252 | 252 |
| V2613/465956-362 | 362 |
| V2614/465956-373 | 373 |
| V2615/465956-383 | 383 |
| V2616/465956-393 | 393 |
| V2617/465956-412 | 412 |
| V2618/465956-422 | 422 |
| V2619/465956-433 | 433 |

Remix continued

| | |
|------------------|-----|
| V2620/465956-443 | 443 |
| V2621/465956-452 | 452 |
| V2622/465956-543 | 543 |
| V2623/465956-612 | 612 |
| V2624/465956-632 | 632 |
| V2625/465956-643 | 643 |
| V2626/465956-653 | 653 |
| V2627/465956-662 | 662 |
| V2628/465956-672 | 672 |
| V2629/465956-682 | 682 |
| V2630/465956-692 | 692 |
| V2631/465956-722 | 722 |
| V2632/465956-733 | 733 |
| V2633/465956-743 | 743 |
| V2634/465956-753 | 753 |
| V2635/465956-762 | 762 |
| V2636/465956-773 | 773 |
| V2637/465956-783 | 783 |
| V2638/465956-823 | 823 |
| V2639/465956-842 | 842 |
| V2640/465956-852 | 852 |
| V2641/465956-873 | 873 |
| V2642/465956-912 | 912 |
| V2643/465956-923 | 923 |
| V2644/465956-933 | 933 |
| V2645/465956-942 | 942 |
| V2646/465956-962 | 962 |
| V2647/465956-973 | 973 |
| V2648/465956-982 | 982 |
| V2649/465956-954 | 954 |

Rove - Maharam

| | |
|---|------------|
| 54" wide | |
| 100% solution-dyed polyolefin with silver-based antimicrobial | |
| ZRV01/466096-001 | Rice |
| ZRV02/466096-002 | Soba |
| ZRV03/466096-003 | Owl |
| ZRV04/466096-004 | Till |
| ZRV05/466096-005 | Dijon |
| ZRV06/466096-006 | Mum |
| ZRV07/466096-007 | Nasturtium |
| ZRV08/466096-008 | Vixen |
| ZRV09/466096-009 | Roast |
| ZRV10/466096-010 | Llama |
| ZRV11/466096-011 | Rind |
| ZRV12/466096-012 | Grackle |
| ZRV13/466096-013 | Indigo |
| ZRV14/466096-014 | Drip |
| ZRV15/466096-015 | Neptunia |
| ZRV16/466096-016 | Pomelo |
| ZRV17/466096-017 | Fairy |

Runner Standard - Maharam

| | |
|--|-----------|
| 58" wide | |
| 57% post-industrial recycled polyester | |
| 43% post-consumer recycled polyester | |
| ZRA07/466167-007 | Bluff |
| ZRA08/466167-008 | Arid |
| ZRA09/466167-009 | Grove |
| ZRA10/466167-010 | Starboard |
| ZRA11/466167-011 | Plot |
| ZRA12/466167-012 | Carousel |

Seam - Maharam

| | |
|----------------------------------|----------|
| 54" wide | |
| 100% polyester | |
| PFOA-Free stain resistant finish | |
| Acrylic backing | |
| ZSM01/466289-001 | Reed |
| ZSM02/466289-002 | Console |
| ZSM03/466289-003 | Play |
| ZSM04/466289-004 | Jock |
| ZSM05/466289-005 | Engine |
| ZSM06/466289-006 | Haunted |
| ZSM07/466289-007 | Transmit |
| ZSM08/466289-008 | Spark |
| ZSM09/466289-009 | Storm |
| ZSM10/466289-010 | Tunnel |

Sequence - Maharam

| | |
|---|-----------|
| 54" wide | |
| 100% solution-dyed polyolefin with silver-based antimicrobial | |
| Z3101/466179-001 | Driftwood |
| Z3102/466179-002 | Boardwalk |
| Z3103/466179-003 | Rattan |
| Z3104/466179-004 | Alfresco |
| Z3105/466179-005 | Plunge |
| Z3106/466179-006 | Starboard |
| Z3107/466179-007 | Veranda |
| Z3108/466179-008 | Lodge |
| Z3109/466179-009 | Flare |

Shuttle Standard - Maharam

| | |
|--|---------|
| 54" wide | |
| 84% post-industrial recycled polyester | |
| 16% post-consumer recycled polyester | |
| ZSS16/466168-016 | Clam |
| ZSS17/466168-017 | Plateau |
| ZSS18/466168-018 | Shoal |

Price category F continued on next page

- Maharam textiles are on assigned lead times A unless otherwise noted.
- Fabric numbers are listed as Herman Miller fabric number/Maharam fabric number.

Maharam® Colors – Seating

continued

Price Category F

continued

Price Category G

Appendix: Maharam Colors – Seating

| Strum - Maharam | |
|--|------------|
| 54" wide | |
| 100% polyurethane with silver-based antimicrobial | |
| Z3301/466122-001 | Overcast |
| Z3302/466122-002 | Ridge |
| Z3303/466122-003 | Twilight |
| Z3304/466122-004 | Pigeon |
| Z3305/466122-005 | Char |
| Z3306/466122-006 | Cabin |
| Z3307/466122-007 | Bur |
| Z3308/466122-008 | Abalone |
| Z3309/466122-009 | Prawn |
| Z3310/466122-010 | Gourd |
| Z3311/466122-011 | Wheat |
| Z3312/466122-012 | Lemongrass |

| Waxen - Maharam | |
|------------------|----------|
| 54" wide | |
| 100% polyester | |
| ZWX01/466078-001 | Appear |
| ZWX03/466078-003 | Savanna |
| ZWX05/466078-005 | Frozen |
| ZWX06/466078-006 | Highland |
| ZWX07/466078-007 | Patina |
| ZWX10/466078-010 | Ruby |
| ZWX11/466078-011 | Ember |
| ZWX12/466078-012 | Harvest |
| ZWX14/466078-014 | Fresh |
| ZWX16/466078-016 | Jay |
| ZWX17/466078-017 | Gazer |
| ZWX19/466078-019 | Bayou |

| Coin Crypton - Maharam | |
|---|----------|
| 54" wide | |
| 43% polyester 37% post-industrial recycled polyester 20% post-consumer recycled polyester | |
| Crypton Green finish and backing | |
| ZC901/466236-001 | Nickel |
| ZC902/466236-002 | Diner |
| ZC903/466236-003 | Copper |
| ZC904/466236-004 | Maroon |
| ZC905/466236-005 | Penny |
| ZC906/466236-006 | Exchange |
| ZC907/466236-007 | Lead |

| Coincide High Performance- Maharam | |
|------------------------------------|----------|
| 54" wide | |
| 100% polyester | |
| ZCF02/466132-002 | Drizzle |
| ZCF03/466132-003 | Cicada |
| ZCF04/466132-004 | Bungalow |
| ZCF07/466132-007 | Raisin |
| ZCF10/466132-010 | Woodland |
| ZCF11/466132-011 | Acre |

| Colline - Maharam | |
|-------------------------------------|-----|
| 55" wide | |
| 75% wool 17% acrylic 8% nylon | |
| ZCQ01/466155-108 | 108 |
| ZCQ02/466155-118 | 118 |
| ZCQ03/466155-148 | 148 |
| ZCQ04/466155-188 | 188 |
| ZCQ05/466155-228 | 228 |
| ZCQ06/466155-348 | 348 |
| ZCQ07/466155-448 | 448 |
| ZCQ08/466155-548 | 548 |
| ZCQ09/466155-568 | 568 |
| ZCQ10/466155-668 | 668 |
| ZCQ11/466155-688 | 688 |
| ZCQ12/466155-788 | 788 |

| Compound - Maharam | |
|---|-----|
| 54" wide | |
| 100% polyurethane silane-based antimicrobial | |
| ZC201/466196-001 | 001 |
| ZC202/466196-002 | 002 |
| ZC203/466196-003 | 003 |
| ZC204/466196-004 | 004 |
| ZC205/466196-005 | 005 |
| ZC206/466196-006 | 006 |
| ZC207/466196-007 | 007 |
| ZC208/466196-008 | 008 |
| ZC209/466196-009 | 009 |
| ZC210/466196-010 | 010 |
| ZC211/466196-011 | 011 |
| ZC212/466196-012 | 012 |
| ZC213/466196-013 | 013 |
| ZC214/466196-014 | 014 |
| ZC215/466196-015 | 015 |
| ZC216/466196-016 | 016 |
| ZC217/466196-017 | 017 |
| ZC218/466196-018 | 018 |
| ZC219/466196-019 | 019 |

| Disc Crypton - Maharam | |
|--|---------|
| 57" wide | |
| 100% polyester Crypton finish and backing | |
| ZD201/466237-001 | Nude |
| ZD202/466237-002 | Khaki |
| ZD203/466237-003 | Festive |
| ZD204/466237-004 | Vibrant |
| ZD205/466237-005 | Somber |
| ZD206/466237-006 | Warm |
| ZD207/466237-007 | Steel |

| Divide Crypton - Maharam | |
|---|----------|
| 57" wide | |
| 45% polyester 36% post-industrial recycled polyester 19% post-consumer recycled polyester | |
| Crypton Green finish and backing | |
| ZD401/466238-001 | Ecru |
| ZD402/466238-002 | Café |
| ZD403/466238-003 | Concrete |
| ZD404/466238-004 | Forest |
| ZD405/466238-005 | Tropic |
| ZD406/466238-006 | Lagoon |
| ZD407/466238-007 | Mocha |
| ZD408/466238-008 | Singe |
| ZD409/466238-009 | Cayenne |

| Divina MD - Maharam | |
|---------------------|-----|
| 59" wide | |
| 100% wool | |
| Z2301/466150-193 | 193 |
| Z2302/466150-203 | 203 |
| Z2303/466150-213 | 213 |
| Z2304/466150-293 | 293 |
| Z2305/466150-343 | 343 |
| Z2306/466150-353 | 353 |
| Z2307/466150-363 | 363 |
| Z2308/466150-413 | 413 |
| Z2309/466150-433 | 433 |
| Z2310/466150-453 | 453 |
| Z2311/466150-613 | 613 |
| Z2312/466150-633 | 633 |
| Z2313/466150-653 | 653 |
| Z2314/466150-673 | 673 |
| Z2315/466150-683 | 683 |
| Z2316/466150-713 | 713 |
| Z2317/466150-733 | 733 |
| Z2318/466150-743 | 743 |
| Z2319/466150-753 | 753 |
| Z2320/466150-773 | 773 |
| Z2321/466150-783 | 783 |
| Z2322/466150-813 | 813 |
| Z2323/466150-843 | 843 |
| Z2324/466150-873 | 873 |
| Z2325/466150-913 | 913 |
| Z2326/466150-943 | 943 |
| Z2327/466150-973 | 973 |

- Maharam textiles are on assigned lead times A unless otherwise noted.
- Fabric numbers are listed as Herman Miller fabric number/Maharam fabric number.

Price category G continued on next page

Maharam® Colors – Seating

continued

Price Category G

continued

| Divina - Maharam | |
|------------------|-----|
| 59" wide | |
| 100% wool | |
| TF01/460730-154 | 154 |
| TF03/460730-171 | 171 |
| TF04/460730-173 | 173 |
| TF05/460730-181 | 181 |
| TF06/460730-191 | 191 |
| TF08/460730-224 | 224 |
| TF10/460730-334 | 334 |
| TF13/460730-384 | 384 |
| TF14/460730-393 | 393 |
| TF16/460730-444 | 444 |
| TF17/460730-462 | 462 |
| TF18/460730-542 | 542 |
| TF19/460730-552 | 552 |
| TF20/460730-562 | 562 |
| TF22/460730-584 | 584 |
| TF23/460730-623 | 623 |
| TF25/460730-652 | 652 |
| TF26/460730-662 | 662 |
| TF27/460730-671 | 671 |
| TF29/460730-684 | 684 |
| TF30/460730-691 | 691 |
| TF31/460730-692 | 692 |
| TF33/460730-712 | 712 |
| TF37/460730-742 | 742 |
| TF41/460730-782 | 782 |
| TF42/460730-791 | 791 |
| TF43/460730-793 | 793 |
| TF47/460730-893 | 893 |
| TF49/460730-922 | 922 |
| TF51/460730-944 | 944 |
| TF53/460730-984 | 984 |
| TF55/460730-106 | 106 |
| TF56/460730-236 | 236 |
| TF57/460730-246 | 246 |
| TF58/460730-346 | 346 |
| TF59/460730-356 | 356 |
| TF60/460730-376 | 376 |
| TF61/460730-426 | 426 |
| TF62/460730-526 | 526 |
| TF63/460730-536 | 536 |
| TF64/460730-626 | 626 |

| Divina continued | |
|------------------|-----|
| TF65/460730-636 | 636 |
| TF66/460730-666 | 666 |
| TF67/460730-676 | 676 |
| TF68/460730-686 | 686 |
| TF69/460730-696 | 696 |
| TF70/460730-756 | 756 |
| TF71/460730-826 | 826 |
| TF72/460730-836 | 836 |
| TF73/460730-846 | 846 |
| TF74/460730-856 | 856 |
| TF75/460730-876 | 876 |
| TF76/460730-886 | 886 |
| TF77/460730-936 | 936 |
| TF78/460730-956 | 956 |
| TF79/460730-966 | 966 |

| Divina Melange – Maharam | |
|--------------------------|-----|
| 59" wide | |
| 100% wool | |
| TG01/460830-120 | 120 |
| TG02/460830-170 | 170 |
| TG03/460830-180 | 180 |
| TG04/460830-220 | 220 |
| TG05/460830-260 | 260 |
| TG06/460830-280 | 280 |
| TG07/460830-871 | 871 |
| TG08/460830-821 | 821 |
| TG09/460830-771 | 771 |
| TG10/460830-721 | 721 |
| TG11/460830-731 | 731 |
| TG12/460830-681 | 681 |
| TG13/460830-631 | 631 |
| TG15/460830-671 | 671 |
| TG16/460830-581 | 581 |
| TG17/460830-531 | 531 |
| TG18/460830-521 | 521 |
| TG19/460830-571 | 571 |
| TG20/460830-421 | 421 |
| TG21/460830-471 | 471 |
| TG22/460830-931 | 931 |
| TG24/460830-971 | 971 |
| TG25/460830-925 | 925 |
| TG26/460830-620 | 620 |

| Emboss - Maharam | |
|-------------------|-------------|
| 54" wide | |
| 100% polyurethane | |
| Polyester backing | |
| ZEM01/466281-001 | Bronze |
| ZEM02/466281-002 | Brass |
| ZEM03/466281-003 | Gold |
| ZEM04/466281-004 | Platinum |
| ZEM05/466281-005 | Silver |
| ZEM06/466281-006 | Aqua |
| ZEM07/466281-007 | Aegean |
| ZEM08/466281-008 | Cobalt |
| ZEM09/466281-009 | Ultraviolet |
| ZEM10/466281-010 | Copper |
| ZEM11/466281-011 | Molten |

| Fold - Maharam | |
|-------------------|----------|
| 54" wide | |
| 100% polyurethane | |
| Polyester backing | |
| ZF101/466292-001 | Jet |
| ZF102/466292-002 | Chalk |
| ZF103/466292-003 | Smoke |
| ZF104/466292-004 | Putty |
| ZF105/466292-005 | Fatigue |
| ZF106/466292-006 | Splash |
| ZF107/466292-007 | Apple |
| ZF108/466292-008 | Moss |
| ZF109/466292-009 | Graphite |
| ZF110/466292-010 | Midnight |

| Hero by Kvadrat - Maharam | |
|---------------------------|-----|
| 55" wide | |
| 96% wool | |
| 4% nylon | |
| ZH101/466318-101 | 101 |
| ZH102/466318-141 | 141 |
| ZH103/466318-151 | 151 |
| ZH104/466318-181 | 181 |
| ZH105/466318-191 | 191 |
| ZH106/466318-201 | 201 |
| ZH107/466318-211 | 211 |
| ZH108/466318-231 | 231 |
| ZH109/466318-311 | 311 |
| ZH110/466318-381 | 381 |
| ZH111/466318-411 | 411 |
| ZH112/466318-441 | 441 |
| ZH113/466318-451 | 451 |
| ZH114/466318-481 | 481 |
| ZH115/466318-511 | 511 |
| ZH116/466318-541 | 541 |
| ZH117/466318-551 | 551 |
| ZH118/466318-601 | 601 |
| ZH119/466318-681 | 681 |
| ZH120/466318-701 | 701 |
| ZH121/466318-711 | 711 |
| ZH122/466318-751 | 751 |
| ZH123/466318-791 | 791 |
| ZH124/466318-901 | 901 |
| ZH125/466318-931 | 931 |
| ZH126/466318-941 | 941 |
| ZH127/466318-981 | 981 |
| ZH128/466318-991 | 991 |

Price category G continued on next page

Appendix: Maharam Colors – Seating

- Maharam textiles are on assigned lead times **A** unless otherwise noted.
- Fabric numbers are listed as Herman Miller fabric number/Maharam fabric number.

Maharam® Colors – Seating

continued

Price Category G

continued

Appendix: Maharam Colors – Seating

| Omen - Maharam | |
|--|-----------|
| 54" wide | |
| 75% polyester | |
| 16% post-industrial recycled polyester | |
| 9% post-consumer recycled polyester | |
| ZQM01/466172-001 | Clam |
| ZQM02/466172-002 | Pewter |
| ZQM03/466172-003 | Hazel |
| ZQM04/466172-004 | Grain |
| ZQM05/466172-005 | Bundle |
| ZQM07/466172-007 | Glacier |
| ZQM08/466172-008 | Surf |
| ZQM09/466172-009 | Wade |
| ZQM10/466172-010 | Marble |
| ZQM11/466172-011 | Silt |
| ZQM12/466172-012 | Persimmon |
| ZQM13/466172-013 | Rocket |

| Pick Crypton - Maharam | |
|----------------------------|----------|
| 54" wide | |
| 100% polyester | |
| Crypton finish and backing | |
| ZP102/466235-002 | Olive |
| ZP103/466235-003 | Slate |
| ZP104/466235-004 | Espresso |
| ZP105/466235-005 | Pepper |
| ZP106/466235-006 | Masala |
| ZP107/466235-007 | Fresh |
| ZP108/466235-008 | Cool |
| ZP109/466235-009 | Ink |
| ZP110/466235-010 | Jet |

| Pocket - Maharam | |
|------------------------|-----|
| 54" wide | |
| 76% recycled polyester | |
| 24% nylon | |
| ZP301/466243-001 | 001 |
| ZP302/466243-002 | 002 |
| ZP303/466243-003 | 003 |
| ZP304/466243-004 | 004 |
| ZP305/466243-005 | 005 |
| ZP306/466243-006 | 006 |
| ZP307/466243-007 | 007 |

| Ring - Maharam | |
|--|---------|
| 54" wide | |
| 48% polyester | |
| 34% post-industrial recycled polyester | |
| 18% post-consumer recycled polyester | |
| ZRG02/466182-002 | Flax |
| ZRG04/466182-004 | Black |
| ZRG05/466182-005 | Scarlet |
| ZRG06/466182-006 | Rust |
| ZRG07/466182-007 | Green |
| ZRG09/466182-009 | Royal |

| Runner - Maharam | |
|--|-----------|
| 54" wide | |
| 57% post-industrial recycled polyester | |
| 43% post-consumer recycled polyester | |
| ZRF01/466108-001 | Bluff |
| ZRF02/466108-002 | Arid |
| ZRF03/466108-003 | Grove |
| ZRF04/466108-004 | Starboard |
| ZRF05/466108-005 | Plot |
| ZRF06/466108-006 | Carousel |

| Sheen - Maharam | |
|---|-------------|
| 54" wide | |
| 100% polyurethane with silane-based antimicrobial | |
| ZSN01/466246-001 | Sail |
| ZSN02/466246-002 | Silver |
| ZSN03/466246-003 | Pewter |
| ZSN04/466246-004 | Hearth |
| ZSN05/466246-005 | Fern |
| ZSN06/466246-006 | Bog |
| ZSN07/466246-007 | Cricket |
| ZSN08/466246-008 | Clove |
| ZSN09/466246-009 | Mystic |
| ZSN10/466246-010 | Vat |
| ZSN11/466246-011 | Huckleberry |
| ZSN12/466246-012 | Mauve |
| ZSN13/466246-013 | Brick |
| ZSN14/466246-014 | Ruby |
| ZSN15/466246-015 | Dragon |
| ZSN16/466246-016 | Kumquat |
| ZSN17/466246-017 | Cinnamon |
| ZSN18/466246-018 | Alder |
| ZSN19/466246-019 | Fog |
| ZSN20/466246-020 | Olive |
| ZSN21/466246-021 | Bronze |
| ZSN22/466246-022 | Crystal |

| Steelcut - Maharam | |
|--------------------|-----|
| 55" wide | |
| 90% wool | |
| 10% nylon | |
| ZSE01/464470-110 | 110 |
| ZSE02/464470-120 | 120 |
| ZSE03/464470-135 | 135 |
| ZSE04/464470-140 | 140 |
| ZSE05/464470-155 | 155 |
| ZSE06/464470-160 | 160 |
| ZSE07/464470-180 | 180 |
| ZSE08/464470-190 | 190 |
| ZSE09/464470-220 | 220 |
| ZSE10/464470-240 | 240 |
| ZSE11/464470-255 | 255 |
| ZSE12/464470-265 | 265 |
| ZSE13/464470-365 | 365 |
| ZSE14/464470-370 | 370 |
| ZSE15/464470-380 | 380 |
| ZSE16/464470-435 | 435 |
| ZSE17/464470-445 | 445 |
| ZSE18/464470-535 | 535 |
| ZSE19/464470-545 | 545 |
| ZSE20/464470-550 | 550 |
| ZSE21/464470-605 | 605 |
| ZSE22/464470-615 | 615 |
| ZSE23/464470-625 | 625 |
| ZSE24/464470-635 | 635 |
| ZSE25/464470-655 | 655 |
| ZSE26/464470-660 | 660 |
| ZSE27/464470-685 | 685 |
| ZSE28/464470-695 | 695 |
| ZSE29/464470-760 | 760 |
| ZSE30/464470-775 | 775 |
| ZSE31/464470-780 | 780 |
| ZSE32/464470-820 | 820 |
| ZSE33/464470-835 | 835 |
| ZSE34/464470-935 | 935 |
| ZSE35/464470-950 | 950 |
| ZSE36/464470-975 | 975 |
| ZSE37/464470-985 | 985 |

Price category G continued on next page

- Maharam textiles are on assigned lead times **A** unless otherwise noted.
- Fabric numbers are listed as Herman Miller fabric number/Maharam fabric number.

Maharam® Colors – Seating

continued

Price Category G

continued

| Steelcut Trio - Maharam | |
|-------------------------|-----|
| 55" wide | |
| 90% wool | |
| 10% nylon | |
| V2501/465906-105 | 105 |
| V2502/465906-113 | 113 |
| V2503/465906-124 | 124 |
| V2504/465906-133 | 133 |
| V2505/465906-144 | 144 |
| V2506/465906-153 | 153 |
| V2507/465906-195 | 195 |
| V2508/465906-205 | 205 |
| V2509/465906-213 | 213 |
| V2510/465906-225 | 225 |
| V2511/465906-235 | 235 |
| V2512/465906-245 | 245 |
| V2513/465906-253 | 253 |
| V2514/465906-283 | 283 |
| V2515/465906-325 | 325 |
| V2516/465906-333 | 333 |
| V2517/465906-353 | 353 |
| V2518/465906-383 | 383 |
| V2519/465906-395 | 395 |
| V2520/465906-413 | 413 |
| V2521/465906-415 | 415 |
| V2522/465906-425 | 425 |
| V2523/465906-453 | 453 |
| V2524/465906-465 | 465 |
| V2525/465906-515 | 515 |
| V2526/465906-533 | 533 |
| V2527/465906-553 | 553 |
| V2528/465906-565 | 565 |
| V2529/465906-645 | 645 |
| V2530/465906-653 | 653 |
| V2531/465906-665 | 665 |
| V2532/465906-675 | 675 |

| Steelcut Trio continued | |
|-------------------------|-----|
| V2533/465906-683 | 683 |
| V2534/465906-713 | 713 |
| V2535/465906-733 | 733 |
| V2536/465906-745 | 745 |
| V2537/465906-753 | 753 |
| V2538/465906-815 | 815 |
| V2539/465906-825 | 825 |
| V2540/465906-845 | 845 |
| V2541/465906-853 | 853 |
| V2542/465906-865 | 865 |
| V2543/465906-883 | 883 |
| V2544/465906-915 | 915 |
| V2545/465906-933 | 933 |
| V2546/465906-945 | 945 |
| V2547/465906-953 | 953 |
| V2548/465906-965 | 965 |

| Stride - Maharam | |
|--|----------|
| 58" wide | |
| 40% post-industrial recycled polyester | |
| 39% polyester | |
| 21% post-consumer recycled polyester | |
| PFOA-Free stain resistant finish | |
| Acrylic backing | |
| ZS101/466252-001 | Sand |
| ZS102/466252-002 | Cave |
| ZS103/466252-003 | Midnight |
| ZS104/466252-004 | Moss |
| ZS105/466252-005 | Fauna |
| ZS106/466252-006 | Ember |

| Ticker - Maharam | |
|--|----------|
| 54" wide | |
| 47% polyester | |
| 31% post-industrial recycled polyester | |
| 22% post-consumer recycled polyester | |
| Crypton green finish and backing | |
| ZT401/466304-001 | Calm |
| ZT402/466304-002 | Millet |
| ZT403/466304-003 | Sow |
| ZT404/466304-004 | Beaver |
| ZT405/466304-005 | Patch |
| ZT406/466304-006 | Balloon |
| ZT407/466304-007 | Squad |
| ZT408/466304-008 | Bale |
| ZT409/466304-009 | Fecund |
| ZT410/466304-010 | Aquarium |
| ZT411/466304-011 | Drink |
| ZT412/466304-012 | Depth |
| ZT413/466304-013 | Far |

| Vestige - Maharam | |
|-------------------|-----|
| 54" wide | |
| 71% polyester | |
| 29% rayon | |
| ZVT01/466259-001 | 001 |
| ZVT02/466259-002 | 002 |
| ZVT03/466259-003 | 003 |
| ZVT04/466259-004 | 004 |
| ZVT05/466259-005 | 005 |
| ZVT06/466259-006 | 006 |
| ZVT07/466259-007 | 007 |
| ZVT08/466259-008 | 008 |
| ZVT09/466259-009 | 009 |
| ZVT10/466259-010 | 010 |

Price Category H

| Circles – Maharam | |
|-------------------|----------|
| 55" wide | |
| 70% cotton | |
| 30% polyester | |
| ZT01/458310-001 | Khaki |
| ZT02/458310-002 | Fatigue |
| ZT03/458310-003 | Document |
| ZT04/458310-004 | Engine |
| ZT05/458310-005 | Charcoal |

| Crosspatch – Maharam | |
|----------------------|----------|
| 54" wide | |
| 75% rayon | |
| 25% polyester | |
| ZS01/458920-001 | Song |
| ZS02/458920-002 | Fresh |
| ZS04/458920-004 | Document |
| ZS06/458920-006 | Circus |
| ZS08/458920-008 | Grounded |

| Ditto – Maharam | |
|-------------------------|-----------|
| 54" wide | |
| 77% recycled polyester | |
| 23% solution dyed nylon | |
| Z2D1/465993-001 | Nacre |
| Z2D2/465993-002 | Shadow |
| Z2D3/465993-003 | Saddle |
| Z2D9/465993-009 | Fern |
| Z2DA/465993-010 | Fountain |
| Z2DB/465993-011 | Cobalt |
| Z2DC/465993-012 | Iron |
| Z2DD/465993-013 | Driftwood |

| Dot Pattern – Maharam | |
|-----------------------|----------|
| 55" wide | |
| 71% cotton | |
| 29% polyester | |
| ZK01/458300-001 | Document |
| ZK02/458300-002 | Taupe |
| ZK04/458300-004 | Red |
| ZK05/458300-005 | Navy |

Price category H continued on next page

Appendix: Maharam Colors – Seating

- Maharam textiles are on assigned lead times **A** unless otherwise noted.
- Fabric numbers are listed as Herman Miller fabric number/Maharam fabric number.

Maharam® Colors – Seating

continued

Price Category H

continued

Appendix: Maharam Colors – Seating

| Hallingdal - Maharam | |
|----------------------|-----|
| 51" wide | |
| 70% wool | |
| 30% rayon | |
| Z2401/460760-100 | 100 |
| Z2402/460760-103 | 103 |
| Z2403/460760-110 | 110 |
| Z2404/460760-113 | 113 |
| Z2405/460760-116 | 116 |
| Z2406/460760-123 | 123 |
| Z2407/460760-126 | 126 |
| Z2408/460760-130 | 130 |
| Z2409/460760-143 | 143 |
| Z2410/460760-153 | 153 |
| Z2411/460760-166 | 166 |
| Z2412/460760-173 | 173 |
| Z2413/460760-180 | 180 |
| Z2414/460760-190 | 190 |
| Z2415/460760-200 | 200 |
| Z2416/460760-220 | 220 |
| Z2417/460760-224 | 224 |
| Z2418/460760-227 | 227 |
| Z2419/460760-270 | 270 |
| Z2420/460760-350 | 350 |
| Z2421/460760-368 | 368 |
| Z2422/460760-370 | 370 |
| Z2423/460760-376 | 376 |
| Z2424/460760-390 | 390 |
| Z2425/460760-407 | 407 |
| Z2426/460760-420 | 420 |
| Z2427/460760-457 | 457 |
| Z2428/460760-526 | 526 |
| Z2429/460760-547 | 547 |
| Z2430/460760-563 | 563 |
| Z2431/460760-573 | 573 |
| Z2432/460760-590 | 590 |
| Z2433/460760-596 | 596 |
| Z2434/460760-600 | 600 |
| Z2435/460760-657 | 657 |
| Z2436/460760-660 | 660 |
| Z2437/460760-674 | 674 |
| Z2438/460760-680 | 680 |
| Z2439/460760-687 | 687 |

| Hallingdal continued | |
|----------------------|-----|
| Z2440/460760-694 | 694 |
| Z2441/460760-702 | 702 |
| Z2442/460760-723 | 723 |
| Z2443/460760-733 | 733 |
| Z2444/460760-750 | 750 |
| Z2445/460760-753 | 753 |
| Z2446/460760-754 | 754 |
| Z2447/460760-763 | 763 |
| Z2448/460760-764 | 764 |
| Z2449/460760-773 | 773 |
| Z2450/460760-810 | 810 |
| Z2451/460760-840 | 840 |
| Z2452/460760-850 | 850 |
| Z2453/460760-890 | 890 |
| Z2454/460760-907 | 907 |
| Z2455/460760-944 | 944 |
| Z2456/460760-960 | 960 |
| Z2457/460760-968 | 968 |
| Z2458/460760-980 | 980 |

| Offset – Maharam | |
|------------------|------------|
| 54" wide | |
| 40% cotton | |
| 36% nylon | |
| 24% wool | |
| ZQF01/465951-001 | Passage |
| ZQF02/465951-002 | Fieldstone |
| ZQF03/465951-003 | Coast |
| ZQF04/465951-004 | Esplanade |
| ZQF05/465951-005 | Oasis |
| ZQF06/465951-006 | Spice |
| ZQF07/465951-007 | Bloom |

| Small Dot Pattern – Maharam | |
|-----------------------------|---------------------|
| 55" wide | |
| 71% cotton | |
| 29% polyester | |
| ZL01/458320-001 | Document |
| ZL02/458320-002 | Sand |
| ZL03/458320-003 | Khaki |
| ZL04/458320-004 | Taupe |
| ZL05/458320-005 | Charcoal |
| ZL06/458320-006 | Document Reverse |
| ZL07/458320-007 | Red |
| ZL08/458320-008 | Yellow |
| ZL09/458320-009 | Green |

| Tonus - Maharam | |
|------------------|-----|
| 51" wide | |
| 90% wool | |
| 10% helanka | |
| ZTN01/460800-100 | 100 |
| ZTN03/460800-109 | 109 |
| ZTN05/460800-118 | 118 |
| ZTN10/460800-125 | 125 |
| ZTN13/460800-128 | 128 |
| ZTN14/460800-129 | 129 |
| ZTN15/460800-130 | 130 |
| ZTN16/460800-131 | 131 |
| ZTN17/460800-132 | 132 |
| ZTN19/460800-135 | 135 |
| ZTN21/460800-207 | 207 |
| ZTN23/460800-210 | 210 |
| ZTN26/460800-216 | 216 |
| ZTN27/460800-240 | 240 |
| ZTN29/460800-440 | 440 |
| ZTN32/460800-508 | 508 |
| ZTN34/460800-605 | 605 |
| ZTN35/460800-608 | 608 |
| ZTN36/460800-609 | 609 |
| ZTN37/460800-610 | 610 |
| ZTN38/460800-613 | 613 |
| ZTN40/460800-615 | 615 |
| ZTN41/460800-619 | 619 |
| ZTN51/460800-631 | 631 |

| Tonus continued | |
|------------------|-----|
| ZTN54/460800-634 | 634 |
| ZTN56/460800-636 | 636 |
| ZTN59/460800-690 | 690 |
| ZTN62/460800-840 | 840 |
| ZTN63/460800-940 | 940 |
| ZTN65/460800-224 | 224 |
| ZTN66/460800-244 | 244 |
| ZTN67/460800-364 | 364 |
| ZTN68/460800-374 | 374 |
| ZTN69/460800-394 | 394 |
| ZTN70/460800-424 | 424 |
| ZTN71/460800-454 | 454 |
| ZTN72/460800-464 | 464 |
| ZTN73/460800-474 | 474 |
| ZTN74/460800-554 | 554 |
| ZTN75/460800-654 | 654 |
| ZTN76/460800-664 | 664 |
| ZTN77/460800-684 | 684 |
| ZTN78/460800-754 | 754 |
| ZTN79/460800-764 | 764 |
| ZTN80/460800-854 | 854 |
| ZTN81/460800-914 | 914 |
| ZTN82/460800-934 | 934 |
| ZTN83/460800-954 | 954 |
| ZTN84/460800-964 | 964 |
| ZTN85/460800-974 | 974 |

- Maharam textiles are on assigned lead times **A** unless otherwise noted.
- Fabric numbers are listed as Herman Miller fabric number/Maharam fabric number.

Maharam® Colors – Seating

continued

Price Category I

| Latch - Maharam | |
|--|--------|
| 55" wide | |
| 61% cotton | |
| 39% solution-dyed post-industrial recycled nylon | |
| 16% rayon | |
| PFOA-Free stain resistant finish | |
| Acrylic backing | |
| ZLC01/466301-001 | Rescue |
| ZLC02/466301-002 | Guide |
| ZLC03/466301-003 | Rotary |
| ZLC04/466301-004 | Radar |
| ZLC05/466301-005 | Sphere |
| ZLC06/466301-006 | Solemn |

| Teatro - Maharam | |
|--------------------------|---------|
| 55" wide | |
| 100% polyester | |
| Polyester/Cotton backing | |
| ZT201/466309-001 | Crumb |
| ZT202/466309-002 | Dorper |
| ZT203/466309-003 | Herd |
| ZT204/466309-004 | Deep |
| ZT205/466309-005 | Robe |
| ZT206/466309-006 | Heat |
| ZT207/466309-007 | Caspian |
| ZT208/466309-008 | Misty |
| ZT209/466309-009 | Boulder |
| ZT210/466309-010 | Elixir |
| ZT211/466309-011 | Guard |
| ZT212/466309-012 | Throne |

Price Category J

| Tokyo - Maharam | | |
|------------------|-----|--|
| 59" wide | | |
| 67% wool | | |
| 24% polyester | | |
| 9% nylon | | |
| ZT101/466247-112 | 112 | |
| ZT102/466247-132 | 132 | |
| ZT103/466247-182 | 182 | |
| ZT104/466247-242 | 242 | |
| ZT105/466247-252 | 252 | |
| ZT106/466247-352 | 352 | |
| ZT107/466247-432 | 432 | |
| ZT108/466247-632 | 632 | |
| ZT109/466247-652 | 652 | |
| ZT110/466247-682 | 682 | |
| ZT111/466247-692 | 692 | |
| ZT112/466247-732 | 732 | |
| ZT113/466247-782 | 782 | |
| ZT114/466247-952 | 952 | |
| ZT115/466247-982 | 982 | |

Price Category K

| Coda by Kvadrat - Maharam | | |
|---------------------------|-----|--|
| 55" wide | | |
| 90% wool | | |
| 10% nylon | | |
| ZC701/464480-100 | 100 | |
| ZC702/464480-103 | 103 | |
| ZC703/464480-116 | 116 | |
| ZC704/464480-182 | 182 | |
| ZC705/464480-222 | 222 | |
| ZC706/464480-232 | 232 | |
| ZC707/464480-242 | 242 | |
| ZC708/464480-362 | 362 | |
| ZC709/464480-382 | 382 | |
| ZC710/464480-410 | 410 | |
| ZC711/464480-422 | 422 | |
| ZC712/464480-442 | 442 | |
| ZC713/464480-610 | 610 | |
| ZC714/464480-632 | 632 | |
| ZC715/464480-642 | 642 | |
| ZC716/464480-722 | 722 | |
| ZC717/464480-762 | 762 | |
| ZC718/464480-962 | 962 | |

Price Category L

| Minicheck - Maharam | |
|----------------------------------|--|
| 55" wide | |
| 78% cotton | |
| 22% polyester | |
| PFOA-Free stain resistant finish | |
| ZMK01/466268-001 Black/White | |

| Plait High Performance - Maharam | |
|--------------------------------------|---------|
| 58" wide | |
| 53% post-industrial polyester | |
| 32% polyester | |
| 15% post-consumer recycled polyester | |
| ZPF02/466138-002 | Sachet |
| ZPF05/466138-005 | Sequoia |
| ZPF08/466138-008 | Reef |

Maharam® Colors – Seating

continued

Price Category M

Price Category N-Z

Appendix: Maharam Colors – Seating

Fruit - Maharam

54" wide
55% cotton
32% nylon
13% post-consumer recycled
polyester
PFOA-Free stain resistant finish
Acrylic backing
ZF201/466262-001 Opal
ZF202/466262-002 Lime
ZF203/466262-003 Olive
ZF204/466262-004 Sky
ZF205/466262-005 Kernal
ZF206/466262-006 Droplet
ZF207/466262-007 Russet

No fabrics available at this time.

- Maharam textiles are on assigned lead times **A** unless otherwise noted.
- Fabric numbers are listed as Herman Miller fabric number/Maharam fabric number.

For more information about our products and services or to see a list of dealers, please visit us at HermanMiller.com or call (800) 851 1196.

© 2017 Herman Miller, Inc., Zeeland, Michigan

® **HermanMiller**, 3D Intelligent, AO, Action Office, Aeron, ArcSpan, Aside, Avall, Avive, Bubble Lamps, Canvas Office Landscape, Caper, Celle, Co/Struc, Daisyone, Distil, Eames, Eco-Dematerialized, Embody, Envelop, Equa 2, Ergon 3, Ethospace, Exclave, Fine-Tune, FlexFront, Flo, Formcoat, Formwork, Ground Cloth, Herman Miller for the Home, Herman Miller for Healthcare, Intersect, Kinemat, Lapjack, Layout Studio, Lifework, Limerick, Live Unframed, Living Office, Locale, Maharam, Meridian, Mirra, Passage, Pellicle, Perspectives, PostureFit, Public Office Landscape, Resolve, Rodney, Sayl, Setu, Thrive, Tu, Wishbone, and Y-Tower are among the registered trademarks of Herman Miller, Inc., and its owned subsidiaries.

™ 8Z Pellicle, About Face, AireWeave, Albert, Backfit, Bubbletack, Burdick Group, Butterfly Back, Celeste, Cellular Suspension, Clam, Compass, Connect, Cubert, DOT, Duracare, Durawrap, Eames Soft Pad, EnhancedAccess, Everywhere, Flex-Edge, Flute, Harmonic, Herman Miller Select, Hopsak 2, Intent, Iota, Jaw, Keyless Entry, Keyn Chair Group by Herman Miller, Latitude, Locale, Logic Mini, Logic Power Access Solutions, Live OS, Loop, Lyris, Lyris 2, Made-to-Measure Storage, Metaform Portfolio, Motia, Multiscrim, Nelson, Pari, Pixelated Support, Plex, PostureFit SL, Q, Renew, Sense, Soft Pad, Stackable, Stackable Storage, Striad, Swoop, Tone, TriFlex, Twist, Ubi, and Wireframe are among the trademarks of Herman Miller, Inc., and its owned subsidiaries.

SM Herman Miller Options is among the service marks of Herman Miller, Inc.

Alexander Girard® is a registered trademark of The Alexander Girard Estate.

Chemsur® is a registered trademark of Wilsonart International.

Corian® is a registered trademark of E. I. du Pont de Nemours and Company Corporation.

Crypton® is a registered trademark of Crypton, Inc.

DACRON® is a registered trademark of INVISTA S.a r.l.

Edelman® Leather is a registered trademark of Edelman Leather, Inc.

FENIX NTM® is a registered trademark of Arpa Industriale S.p.A.

FLEXNET™ is a trademark of Milliken & Company.

Floor Saver Glide® is a registered trademark of Carpin Manufacturing, Inc.

Geiger® is a registered trademark, and Bumper™, Saiba™, and Ward Bennett™ are trademarks, of Geiger International.

Goetz™ is a trademark of Mark W. Goetz.

Hang-It-All® is a registered trademark of Lucia Eames Demetrios, d.b.a. Eames Office.

Holophane® is a registered trademark of Holophane.

Ingeo™ is a trademark of Cargill Dow LLC.

iPad® is a registered trademark of Apple, Inc.

LifeSize® is a registered trademark of LifeSize Communications, Inc.

Magis®, Bombo®, and Me Too® are registered trademarks of Magis S.p.A.

Microsoft® and Natural® Keyboard are registered trademarks of Microsoft Corporation.

Noguchi® and the Noguchi table configuration (trade dress) are registered trademarks, and Rudder Table™ is a trademark, of The Isamu Noguchi Foundation and Garden Museum.

Place Textiles® is a registered trademark of Place Textiles.

SuperSeat™ is a trademark of Dahti Seating, a division of ITW.