

Installation Instructions



Warning



Low Voltage



Hot Surface

TOOLS NEEDED:

3/32" & 3/16" Allen Wrench

Waterproof Wire Connectors

By Others

INSTRUCTIONS PERTAINING TO A RISK OF FIRE, OR INJURY TO PERSONS IMPORTANT SAFETY INSTRUCTIONS

Lighted lamp is HOT!

WARNING - To reduce the risk of FIRE OR INJURY TO PERSONS: Turn off/unplug and allow to cool before replacing lamp. Lamp gets HOT quickly! Contact only switch/plug when turning on.

Do not touch hot lens, guard, or enclosure (see diagram/picture).

Keep lamp away from materials that may burn. Do not touch the lamp at any time. Use a soft cloth. Oil from skin may damage lamp. Do not operate the luminaire fitting with a missing or damaged shield.

SAVE THESE INSTRUCTIONS

IMPORTANT SAFETY INFORMATION - READ, FOLLOW, AND SAVE ALL SAFETY AND INSTALLATION INSTRUCTIONS

- Product must be installed by a qualified person in a manner consistent with its intended use and in compliance with the National Electrical Code, Canadian Electrical Code, and all Local and Provincial Codes.
- Follow product label information and instructions.
- Qualified Personnel must perform all servicing or relamping of this product.
- Before wiring to power supply and during servicing or relamping, turn off power at fuse or circuit breaker before service.
- The use of accessory equipment not recommended by the manufacturer or installed contrary to instructions may cause an unsafe condition. The use of damaged components may cause an unsafe condition and void product warranty.
- Do not block light emanating from product in whole or part, as this may cause an unsafe condition.
- Never operate the fixture with missing or damaged lens. Lens must be cleaned on regular basis.
- Entire fixture may become extremely hot. Do not touch hot lens or fixture body. Do not touch the lamp at any time. Use a clean, dry, soft cloth to handle the lamp. Oil from skin may damage the lamp and cause it to rupture.
- Replace lamp only with correct wattage and type of lamp marked on fixture label.
- All gaskets, O-rings and sealing surfaces must be kept clean during installation and service; failure to do this may cause an unsafe condition and void product warranty.

IMPORTANT LISTINGS AND CERTIFICATIONS

- Suitable for wet locations • Suitable for recessed in ground locations

Proper soil preparation is recommended before installation. See the DIG-IT guide at www.bklighting.com/dig-it for more information.

Soil Prep



A. Determine Soil Type by referencing DIG-IT Guide. Prep soil according to DIG-IT Guide.

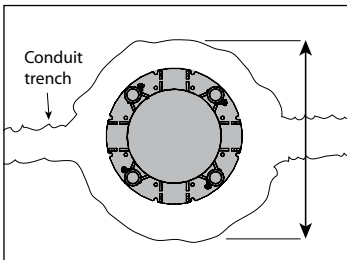

B. Excavate a hole to the necessary dimensions for fixture placement according to lighting plan.

WS

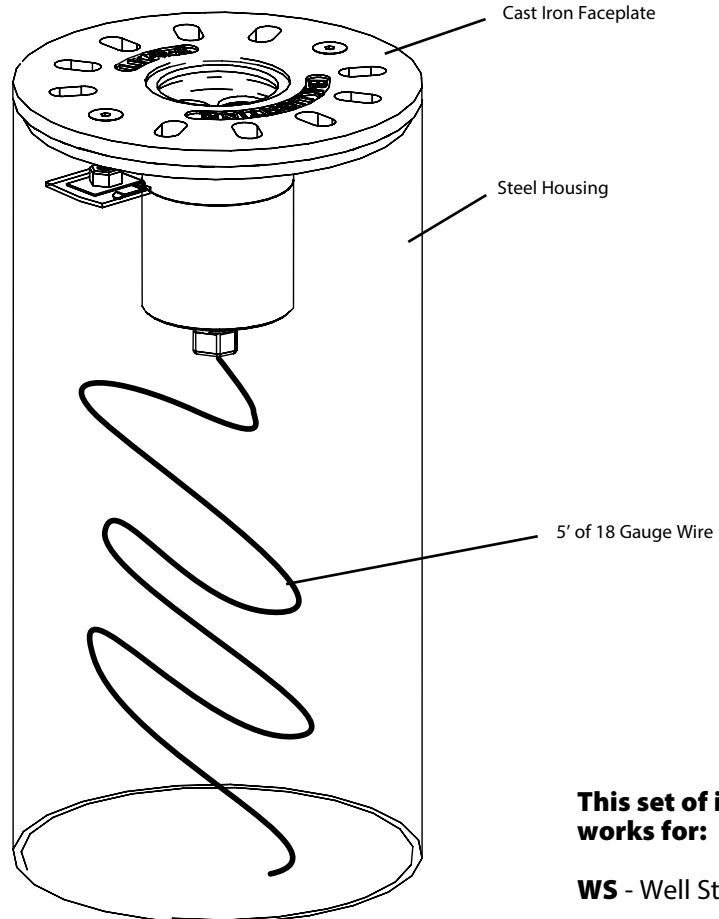

This set of instructions works for:

WS - Well Star™

IMPORTANT SAFETY INFORMATION - READ, FOLLOW, AND SAVE THESE INSTALLATION INSTRUCTIONS

B-K LIGHTING

40429 Brickyard Drive • Madera, CA 93636 • USA
559.438.5800 • FAX 559.438.5900
www.bklighting.com • info@bklighting.com

RELEASE DATE
9-8-15

REFERENCE NUMBER
INS000968

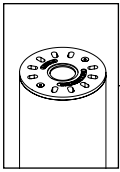

Installation Instructions

PROJECT:	
TYPE:	

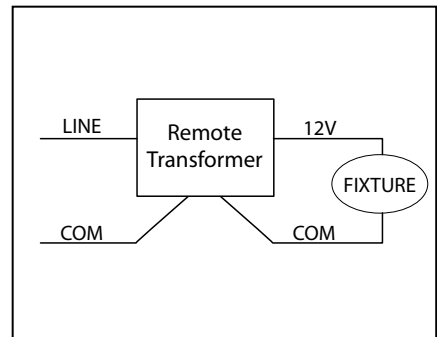
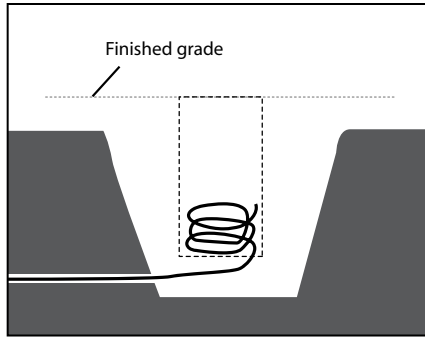
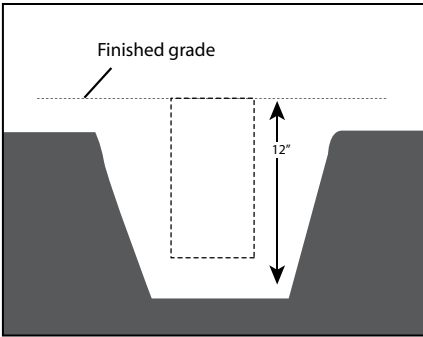

1. Excavate trench according to designed lighting plan, 20" deep and 10" wide suitable for the 13" fixture housing.

2. Supply low voltage wiring necessary for installation (By Others). **See wiring diagram.**

WIRING DIAGRAM

⚠ NOTE: Leave sufficient wire length in the fixture housing for future service.

3. Make watertight connections using proper waterproof connectors (By Others) from remote transformer to fixture leads.

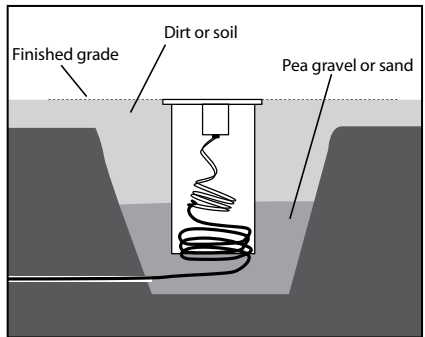
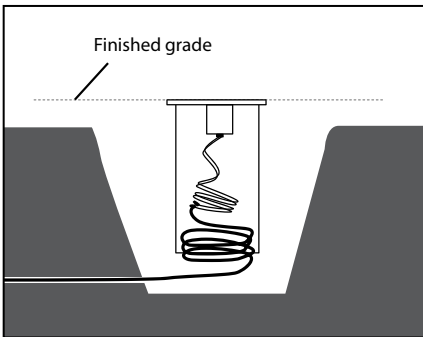

4. Insert fixture housing and low voltage wire into trench.

5. Back fill with pea gravel or sand to allow sufficient drainage. Install housing flush at grade. Install faceplate with (2) 1/4-20 screws using a 3/16" Allen wrench.

**IMPORTANT SAFETY INFORMATION LISTED ON REVERSE
READ, FOLLOW, AND SAVE ALL SAFETY AND INSTALLATION INSTRUCTIONS**

