

MOUNTING INSTRUCTIONS

1. First remove fixture cover by unscrewing two bolts holding cover to can.
2. Push down on LED module male connector clip. This will disengage connector clip from female connector side in fixture. With connector clip free, gently pull connector apart.
3. Remove LED Step Star reflector by unscrewing two bolts, adjacent LED Module, holding reflector in place. See schematic on adjacent page.
4. Using a knife, or very thin flat blade screwdriver, remove reflector and set beside fixture.
5. Select a mounting location for the LED Step Star. Fixture should be within reach of 120VAC power, located 9 inches above the surface to be lit, and situated at the best location along the mounting surface for the illumination task.
6. Make sure LED Step Star is completely wired and inspected before wall is completed. **NOTE: Masonry wall installation warning adjacent schematic, and corrosion warning on reverse side.**
7. LED Step Star has flanges that will allow the can to be securely affixed to almost any surface with the four mounting screws provided. Installations in drywall will require a wood backing behind drywall. Place can in hole (5-1/2" x 4" x 2-1/2") and mark the position of the four mounting screws. Remove can and drill a pilot hole for the screws. Reposition can in hole, and securely fasten the can to the mounting surface by firmly tightening four mounting screws.

WIRING INSTRUCTIONS

CAUTION! Only qualified electricians, or people familiar with household electrical circuits, should bring 120VAC power to the fixture. Wiring may require an inspection by the local building department. Check with your local building department before installation.

CAUTION! Before bringing 120VAC power to the fixture, make sure incoming wire is not "hot" and all power coming to the wire is off.

CAUTION! All connections must be made in accordance with this instructional manual, current NEC, and all local building codes. Minimum 90 C supply conductors.

CAUTION! Use RTV silicone and water-tight fittings on all wet locations connections to fixture.

1. Through one of the three NPT fittings provided, bring in 120VAC power wiring. If 120VAC wire will not conveniently enter one of the three NPT fittings provided, simply unscrew the can, rotate can 180 degrees, and reinstall. Can is entirely symmetrical, and 180 degree rotation will not affect mounting holes.
2. Secure wire to fixture with the appropriate strain relief (not provided).
3. Strip 1/3" (8mm) of the insulation off each incoming 120VAC power wire. Connect white incoming 120VAC wire (neutral wire) to push-in connector on white wire from rectifier. Connect black incoming 120VAC wire to push-in connector on black wire from rectifier. Connect ground wire to push-in connector on green wire screwed into can. Push all wires firmly down into connectors, so that uninsulated wire is not exposed.
4. Reinstall assembly, reflector, LED module and cover.

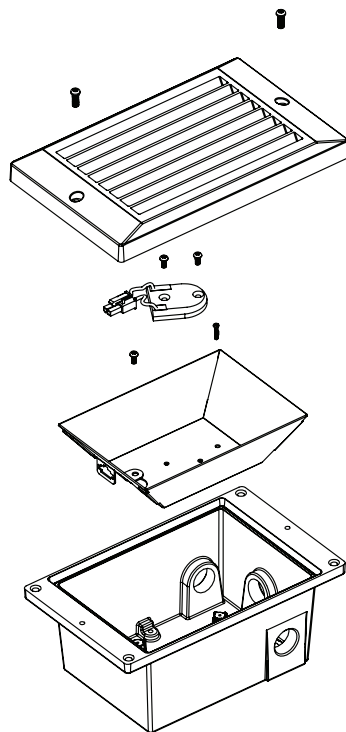

REPLACEMENT OF LED ASSEMBLY

In the highly unlikely event of an LED module failure, please follow the instructions listed below:

CAUTION! If unit has recently been operating, glass lens and LED module are hot! Turn off fixture and allow it to cool for 15 minutes before relamping.

CAUTION! Always replace LED module with all power off to fixture.

NOTE: Using a thin pair of gloves during this procedure will eliminate fingerprints on glass lens and LED module.

1. First remove fixture cover by unscrewing two bolts holding cover to can.
2. Push down on LED module male connector clip. This will disengage connector clip from female connector side in fixture. With connector clip free, gently pull connector apart.
3. Unscrew old LED module. Replace with new LED module (NSL Part No. LEDMOD-32-FF). Tighten bolts just snug.
4. Push male connector from LED module into female connector in fixture. Make sure male connector clip engages to female connector completely.
5. Replace fixture cover by fitting cover to can so gasket seals and screwing in both cover bolts firmly.

WARNING! If this fixture is to be placed in a masonry or brick wall, you must use a Concrete Cap during can installation to provide the proper void for the fixture cover. Failure to use the Concrete Cap will almost guarantee concrete or grout forming against fixture can flange, and poor cover-to-can seal (see below). Poor cover seal will allow water/moisture into fixture resulting in LED failure.

Without Concrete Cap

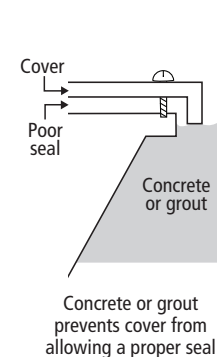

With Concrete Cap

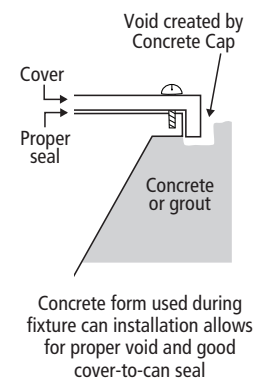

DIMMING

There are two ways at present to dim the LED Step Star:

1. The first option consists of dimmers with forward phase TRIAC design and HED technology. These dimmers tend to be less expensive and have shown very good results. These dimmers also have an advantage of requiring only two wires within the switch box in a single pole configurations (HOT and GROUND). For optimum results these dimmers also have a dimming range adjustment. Maximum load for these dimmers is 150W. Recommended manufacture and model numbers are below:

LUTRON "Skylark" SCL-153P

LUTRON "Skylark Contour" CTCL-153P

LUTRON "Diva" DVCL-153P

2. The second option consists of dimmers with 'trailing edge' electronic design. These dimmers have shown slightly more even dimming results and are generally considerably more expensive. Trailing edge dimmers will require the switch box to contain all three wires (HOT, NEUTRAL, and GROUND). Maximum load for these dimmers is 300W.

Recommended manufactures and model numbers are:

LUTRON "Skylark" SELV-300P

LUTRON "Skylark Contour" CTELV-303P

LUTRON "Diva" DVELV-300P

Note: All the specified dimmers will dim down to 5-10%. All specified dimmers also have an integral on/off switch to eliminate any light from the fixtures. Please read and follow dimmer manufacture instructions.

ANOTHER LED PRODUCT BY NSL

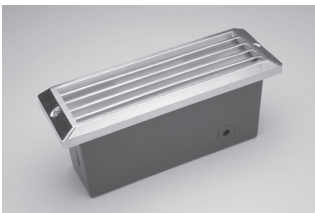

Stainless Steel Louver Cover with fluorocarbon lacquer coated aluminum can. Recommended for use in corrosive environments as salt air, adjacent bodies of water, or installed in caustic materials such as limestone.

THROUGH-WIRE, 120VAC POWER

- Disconnect from all 120VAC power prior to installation.
- Connections must be made in accordance with all local electric codes and/or NEC.
- Minimum 90°C supply conductors.
- Interconnect up to 150 fixtures per 120VAC tap without a dimmer.
- For maximum load with dimmer, consult dimmer instructions.
- 14 gauge (Romex Type) or better wire is required.
- Requires strain reliefs.
- Installations in wet locations should use RTV silicone or water-tight fittings on all connections to fixtures.

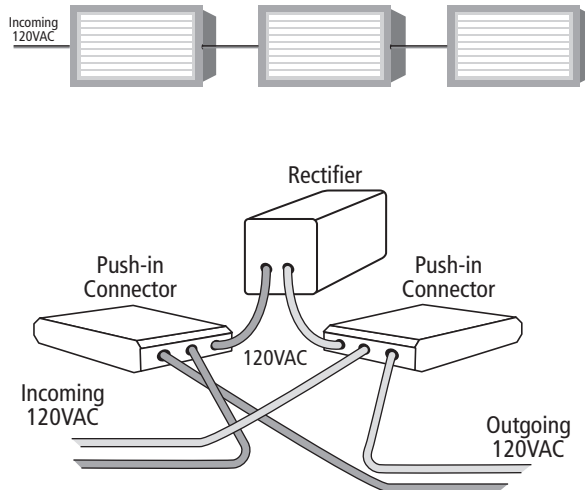

INSTALLATION INSTRUCTIONS

LED STEP STAR

Long lasting 120 VDC LED technology in a die cast aluminum fixture

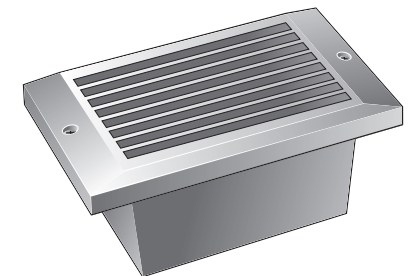

Replaceable 120VDC LED Module with 40,000-hour rated life

Ultra low 5.2 watts per fixture

Dimmable

Louver, Scoop & Prism cover designs

White, Bronze, Black and Aluminum colors

Up to 150 Fixtures per 120VAC tap

Suitable For:
Wet Locations, Insulation Contact
Wall and Ceiling Mount, Showers
Use in Poured Concrete

NATIONAL SPECIALTY LIGHTING
ARCHITECTURAL AND DECORATIVE LIGHTING
2299 Kenmore Ave, Tonawanda, NY 14207
www.nslusa.com

© 2015 National Specialty Lighting

1/15

NSL
NATIONAL SPECIALTY LIGHTING

