

Raised Access Flooring

Installation Manual - February 2014

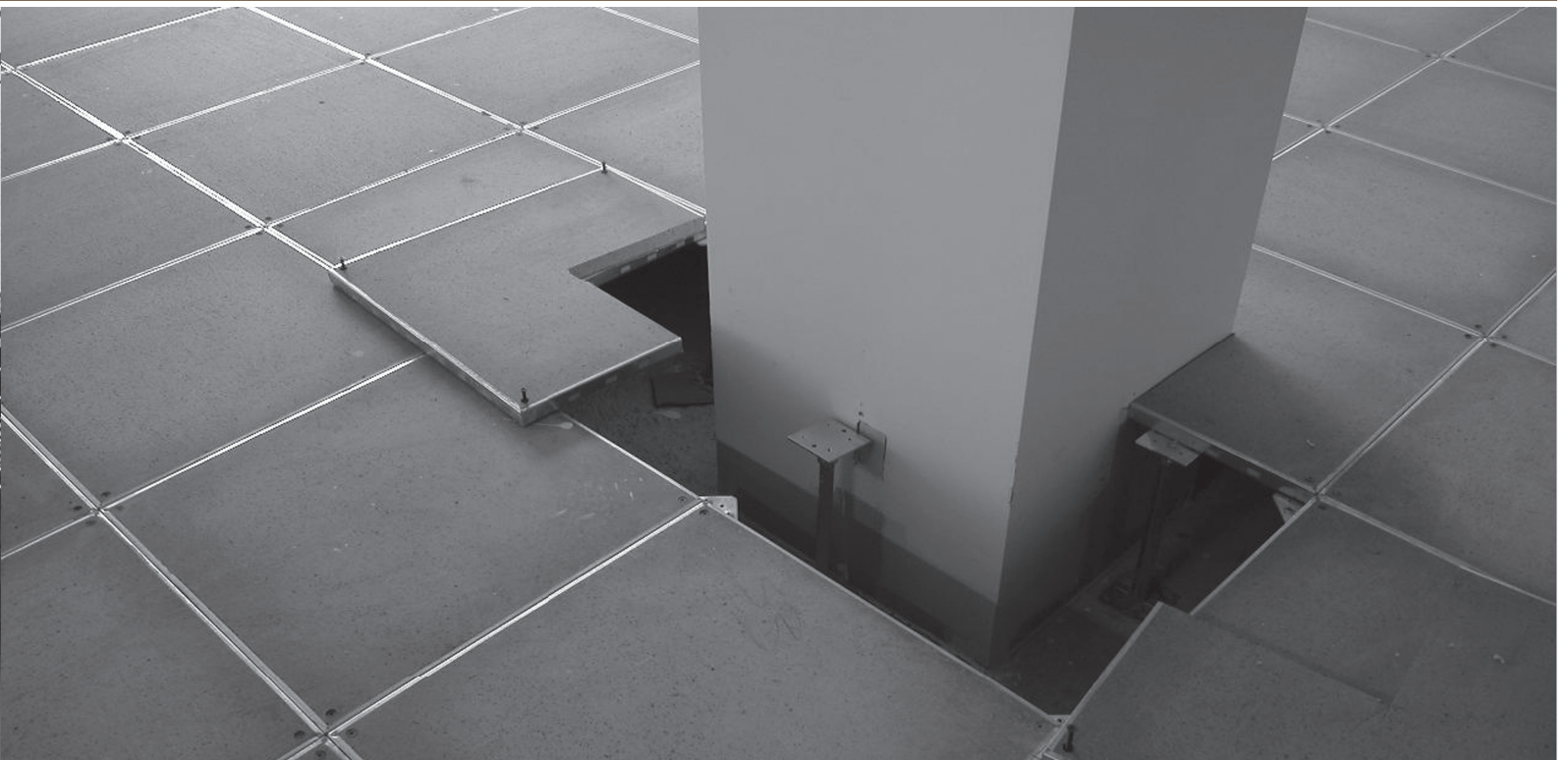

TecCrete: 1250, 1500, 1500sl, 2000, 2500 System

Access Floor Panel

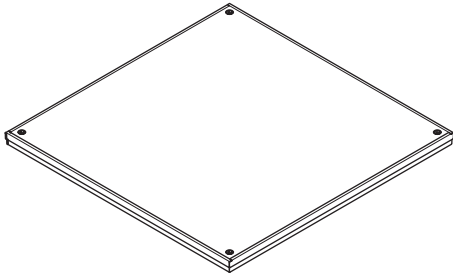

25% Perforated Panel

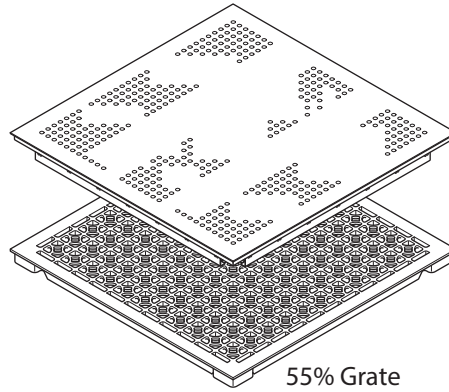

55% Grate Panel

Triad Airflow Panel
Chamfer/Slotted
(shown without handle)

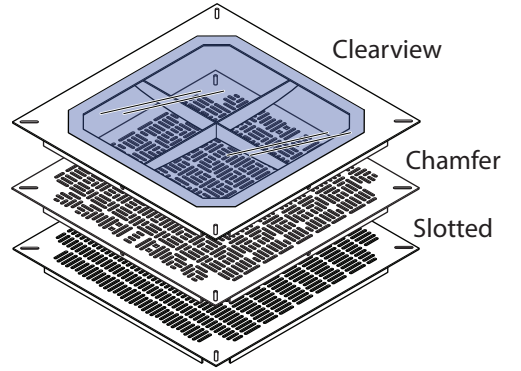

Clearview

Chamfer

Slotted

Field Head

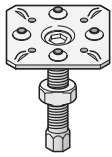

Low Profile Field Head

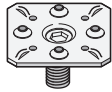

Perimeter Head

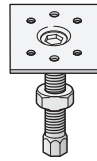

Low Profile Perimeter Head



Seismic Base

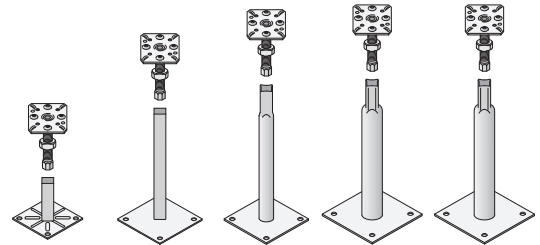

Type 0

Type 1

Type 3

Type 4

Type 5

Low Profile Pedestal Base

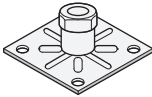

Ultra Low Profile Pedestal Base

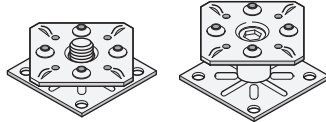

Ramp Swivel Head

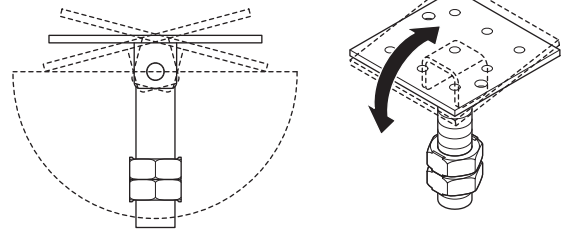

Stringers

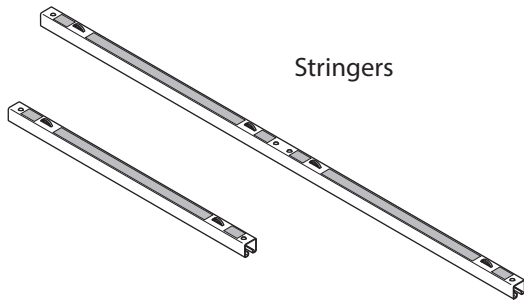

Ramp Shoe

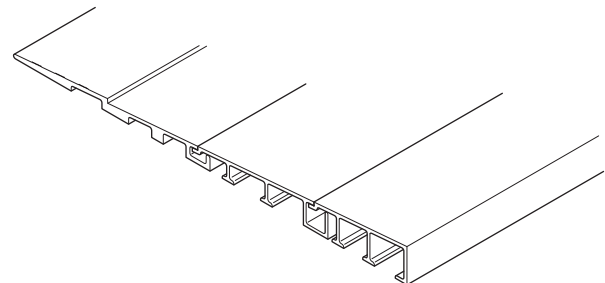
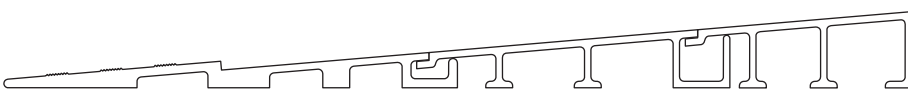

CONTENTS

	Glossary of Terms.....	4
1	System Characteristics.....	5
2	List of Tools.....	7
3	Storage of Materials.....	7
4	Getting Started.....	8
5	Installing Stringers.....	19
6	Trouble Shooting and Final Adjustment.....	26
7	Screws and Fasteners.....	29
8	Sub floors.....	33
9	Cutting Instructions.....	37
10	Lateral Braces/Cutouts.....	40
11	Grounding of the Access Floor System	40
12	Fascia Applications & Step Details.....	42
13	Leakage.....	49
14	Owners Manual.....	50
15	TecCrete Sealing.....	52
16	Warranty Procedure.....	54

GLOSSARY OF TERMS

Adjusting Nut	Nut used in the pedestal assembly to compensate for sub floor variation.
A/F	Access Floor System including panels, pedestals, and accessories.
B/M	Bill of Material.
C/L	Center Line.
Click	1/4 turn of the adjusting nut, approximately 0.014”.
Cuts	Panels which have been altered by cutting to fit a specific location.
Dry Line	A string used as a temporary reference line which establishes the portion of the initial row of panels in the access floor installation.
ELL	Section of access floor laid along perpendicular dry lines forming an L Shape, normally three of four panels wide.
FFH	Finished Floor Height. The dimension from the top of the access floor panel to the sub floor.
Field	The main open area of the floor where full panels are installed.
Free Edge	The point in the installation where panels are being installed on fresh pedestals.
Grid Line	Lines formed by the centerline of the joint between the access floor panels.
Intermediate Pedestals	Pedestals whose elevation is set by using the leveling bar.
Laser	An electronic transit that projects a laser beam to establish elevations.
Leveling Bar	A tubular or extruded straight edge with permanent center line marks at two-foot increments that are used to level and roughly locate intermediate pedestals. Dimensions are at minimum 0.75” x 2.5” x 0.080” wall thickness by 10 feet long. Bar is usually constructed from aluminum to minimize the weight of the leveling bar.
Mechanical Anchor	A fastening device used to attach pedestals or other accessories to the concrete slab instead of adhesive. Typically they require a hole to be drilled in the concrete and a nut placed on the bolt to secure the pedestal and used in seismic or special conditions.
Plumb Pedestal	90 degrees from the horizontal plane.
Base	An assembly of the pedestal tube and base plate.
Pedestal	Assembly of pedestal head, base plate, pedestal tube, adjusting nut, and threaded stud used to support the panels at the required finished floor height.
Primary Pedestals	Pedestals whose elevation is set by using laser or transit and act as supports for the leveling bar.
Rocker	A panel that rocks up and down diagonally when installed.
Shoot In	Establish control height reference points in a sub floor area using a transit or laser.
Start Point	A specific location on the sub floor designated as the installation starting point. Note that this point may not always be in the corner of the room as shown in the illustrations.
Stringer	Lateral member used to connect the pedestals to each other and to support vertical loads. They may be one or two panels in length.
Square	To establish lines which are perpendicular to each other.
Transit.	Builders optical leveling device used for establishing grade levels for floors, ceilings, etc.
Through Bolt	Used to fasten floor track or other components to a raised floor panel. Hole is drilled through panel and device is fastened to the panel using a bolt, washer and nut assembly.

1 SYSTEM CHARACTERISTIC GUIDE

The following installation guide is provided to establish a quick review of the two different panel and understructure systems. The benefits of the different systems are defined and the applications where they would most likely be used.

1.1 Panel Selection

A. TecCrete™ 1 1/8" & 1 1/2" - Concrete Panel - General Office & Computer Room

This patented panel can be used bare or covered in carpet, laminate, vinyl, rubber or other finishes. It is the perfect solution for general office, schools, computer rooms, museums and casinos. Integral corner-lock inserts and non-combustible construction provide the end user with a durable, quiet, and trouble free installation. The nominal bare panel is sized 24" square. The 1.125" thick panel weighs 42 pounds and the 1.5" thick panel weighs 55 pounds. Available in standard finished floor heights of 3" to 63". Contact the factory for higher finished floor heights.

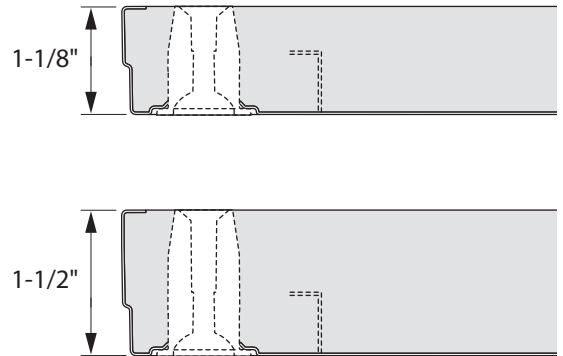

1.2 Understructure Selection

Haworth will offer a recommendation for what type of seismic pedestal should be used for your building based on many factors including but not limited to; location in the country, soil of the building site and height of the building. This recommendation must be approved by a local structural engineer. To have seismic calculations completed please send the seismic calculation form to the floor engineering group for evaluation.

A. Corner-Lock

This system is used in office areas where quietness, firmness underfoot, and complete access are required. The panels are fastened to the pedestal head using a screw which completely interconnects the access floor system laterally and vertically. Once the fasteners are removed and the panels lifted, access to the plenum area is completely unobstructed.

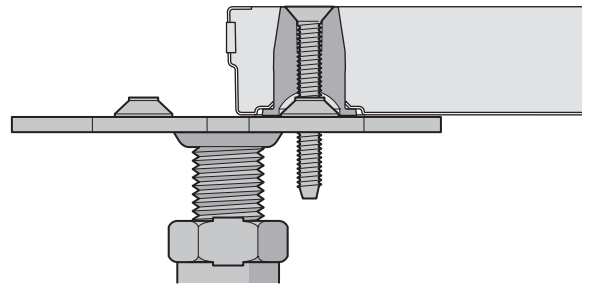

B. Corner-Lock with Bolted Stringers

The panels and stringers are attached to the pedestals with fasteners. This system provides the highest lateral and vertical load carrying capacity available generating the greatest system stability. Access to the under floor area is more difficult due to the number of fasteners used. Typical applications for this system would be seismic zones, factory floors, casinos, and critical test facilities.

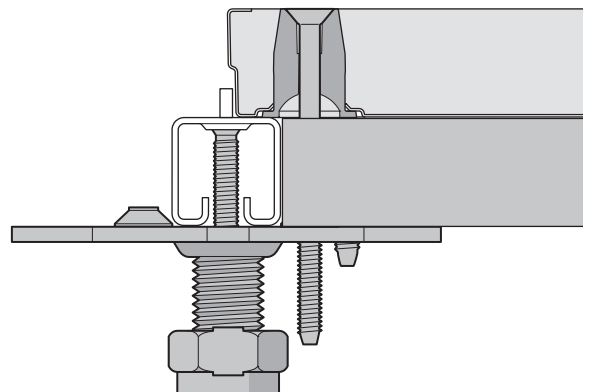

C. Load Bearing Bolted Stringer

The load bearing bolted stringer system uses a fastener to rigidly attach the stringer to the pedestal head while the TecCrete panel is gravity held in place. The panels are free to be readily removed with a standard lifting device while the stringers remain attached to the pedestal to maintain the module spacing and to stabilize the pedestals for lateral movement. These systems are used where system strength, access, rigidity and electrical conductivity are required. Typical applications are high-density offices, computer room areas and spaces over 18" finished floor height.

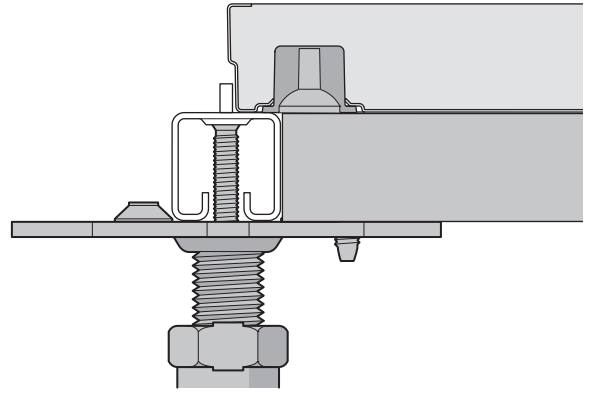

2 LIST OF TOOLS

The list of tools shown here is not intended to be all inclusive or limiting for the installer. Specific manufacturers have been cited as an aid to sourcing equipment which others have found to be effective. Similar equipment can be obtained from other sources.

Small Projects

- Chalk line, chalk, and 2 dry lines
- 24" level (accurate & sensitive)
- Leveling bar
- Extension cords (50 & 100ft)
- Hacksaw w/12- or 14-tooth blades
- 12" adjustable wrench
- 10" adjustable pliers and 8" locking pliers
- Pop rivet gun w /1/8" rivets
- Hole saws, core bits, 1/2" hammer drill
- Tape measures (20 & 100)
- Heavy duty orbital bayonet saw w/14-tooth
- Diamond tip blade
- Set of screw drivers
- Aviation tin snips
- Tripod and optical level or laser
- Metal miter box
- 20oz. claw hammer
- Wood and cold chisels
- Awl
- Metal file
- Vacuum cleaner
- 20"-22" pallet jack

- 3/8" reversible drill w/drill set, counter sink bit, 1/4" flat head bit, hole saw, and core bits
- Double cup lifter
- Carpet lifter
- Safety glasses & gloves

Large Projects

- 14" band saw and blades
- Diamond tipped saw blades
- Shot pin gun and shot pins
- 1/2" drill w/adjustable torque limiting, screw gun, battery or electric power, charger (if needed), carbide tip replacement bits (#2P and #3P).
- Set of carbide or diamond tip bits
- 1/2" minimum plywood overlay material
- Calculator
- Job box

3 STORAGE OF MATERIALS

Access flooring materials are interior products intended for use in an indoor environment. The materials are for interior use and should not be subjected to outside conditions. The installation of an access floor requires a thorough understanding and control of the building space receiving the access floor materials.

Haworth panel systems must be handled as interior materials.

3.1 Proper Conditions for On-Site Storage and Installation of Access Floors

- The customer must provide a dry accessible area to receive and unload material with a free path to elevators, hoists, and/or the area receiving the access floor.
- Prior to the start of installation, a secure and dry storage space closed to the weather must be made available for the access floor materials, with recommended environment at 40 degrees F to 90 degrees F, and approximately 35% to 70% relative humidity.
- The installation area must be closed to the weather, with the recommended environment at 40 degrees F to 90 degrees F, and approximately 35% to 70% relative humidity, 24 hours a day during and after installation.
- The sub floor surface must be free of moisture, dust, dirt, and other debris. After installation, the access floor must be maintained in the same manner.
- It is recommended to acclimatize the materials to the anticipated interior storage usage temperature for 24 hours prior to the start of installation and maintain this temperature throughout the installation process. This will minimize any problems associated with panel size changes due to wide variations in temperature and humidity.

4 GETTING STARTED

All Haworth TecCrete systems use the same basic method to start the installation process. The procedures outlined below, planning, and attention to detail will allow you to install a quality product for your customer. Other methods can be used if proper attention to the installation details are observed. The installation process will be much easier to manage if the installation area is undisturbed during the first two days of assembly. An unlevelled, out of square start may not be correctable without complete reassembly.

4.1 Starting the Installation

1. Free of Trades

The installation area should be free from other trades during the installation. This is especially true during the initial squaring and laying of the first few rows of panels. There should not be any traffic on freshly laid panels as this can cause the module lines to drift, the installation squareness to be lost, and the pedestals to shift resulting in rocking panels. A minimum 48 hour curing period is required for the installation to hold position at the minimum recommended installation temperatures. A minimum of four panel widths of flooring is required to fix the location and squareness of the system.

2. Site Conditions

As soon as possible after the Award of Contract, visit the job site to verify the Plan Drawings, look at the material delivery and storage situations, check the progress and schedule of the job and evaluate the condition of the sub floor. An early visit will allow you to correct any material quantities, pedestal height, or scheduling problems which you may find. If there is more than four weeks to the installation time of the access floor, visit the job site as often as practical to stay current with the job progress. The environmental conditions should follow those outlined in Storage of Materials. Any deviations should be corrected before commencing installation. Verify that the concrete sealer (if used) is compatible with the pedestal adhesive. This is especially true if the specification dictate specific pedestal turnover performances. See the Sealer Section for testing instructions. If any deviations from the Plans are noted, you will need to discuss these with the General Contractor and determine how to address them.

3. Material Delivery

Verify how to get material from the truck to the work area. Answering the following questions will help you have the right manpower and equipment on hand to move the material into the work area.

- Is there a loading dock?
- Can a truck get to it from the street?
- Can you deliver materials inside the building?
- Do you need any ramps to get over obstructions?
- Are there elevators and what is the schedule for lifting your material? Can you use a hoist to bring material into the area?
- How must the materials be distributed in the installation area?

Once the truck arrives it is your responsibility to check the Bill of Lading to determine if it agrees with that materials are on the truck. Any differences or damaged materials must be noted and forwarded to the trucking company for corrective action. Do this immediately.

After verifying the material counts disperse the material to the work area. This will also help minimize the labor for moving material when installing panels. Do not stack all the material in one location. Access floor materials can weight 300 pounds per square foot when skids of panels are stacked next to each other. Most above ground slabs are rated at 50 -150 pounds per square foot. Do not place more than 25 - 30 skids per bay of the building.

PLEASE POST IN WORK AREA FOR REFERENCE:

NOTE: All corner-lock fasteners (A) should be tightened to **40 in-lbs** maximum.

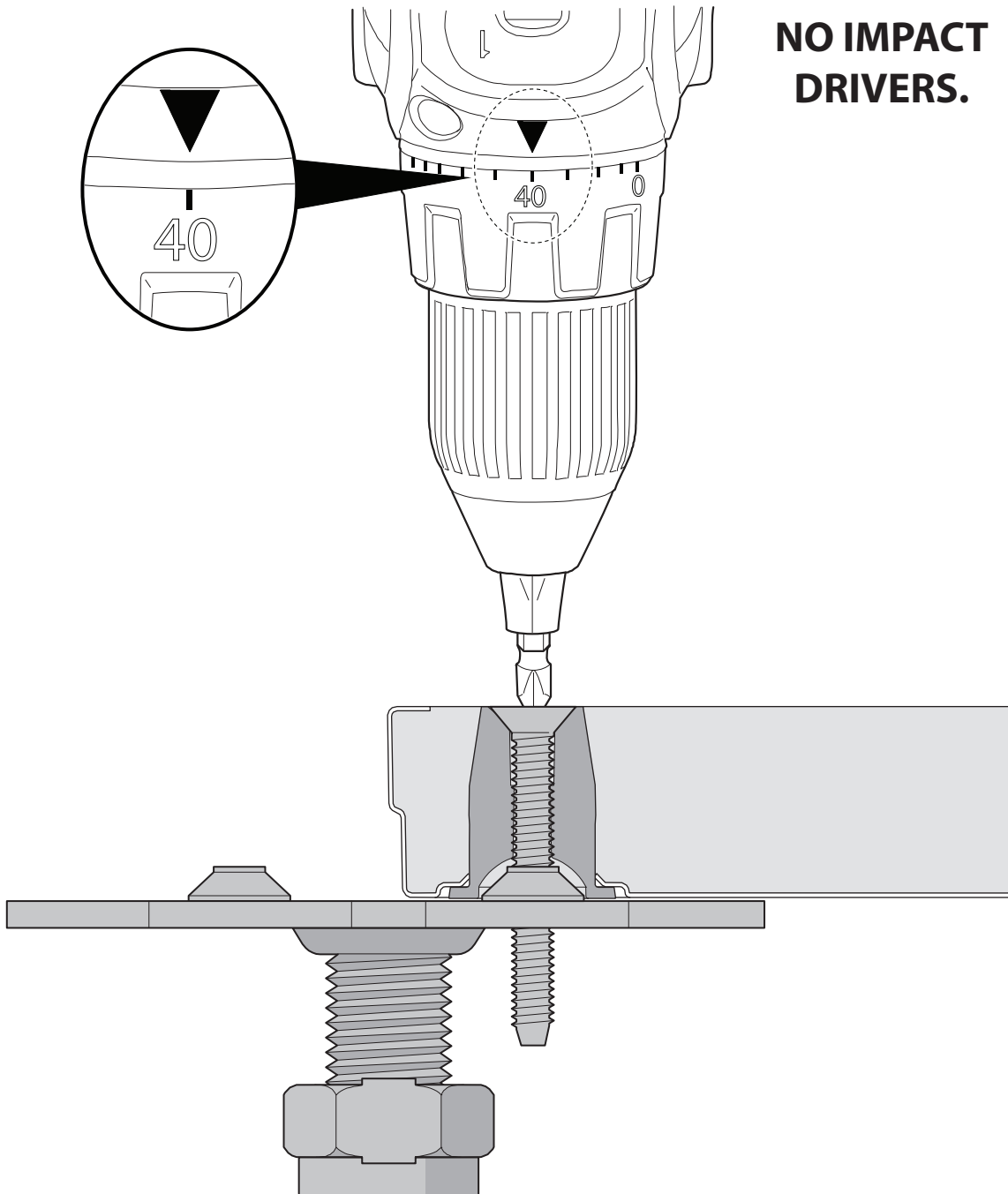

4. Pre-Construction Meeting with Trades

Any successful construction project requires cooperation and understanding from everyone working on the project. Access floors are no different. In fact most trades may not be familiar with the access floor installation process or what is important to enable you to install the product quickly and without problems. If possible, you should meet with the other trades to discuss the access floor installation process and how to work with their needs so you both may have a fast and profitable installation with minimum interference.

You should provide the following:

- Start points for each area.
- Layout chalk lines for pedestal runs or spray paint a 10 x 10 grid of approximate pedestal locations. This will enable the other trades to stay clear of the pedestal locations.
- Since access floors are an interior finish, it is advisable to have any overhead work completed before the access floor installation begins. Damage may result to the access floor panels if the overhead work is performed on top of the access floor.
- Inform all trades of the rolling load and concentrated load rating of the systems being installed. Ask them about any lifts the crews may be using. Battery powered lifts have very high rolling loads. Make sure the wheel loads are in compliance with the floor systems capabilities. Contact the flooring engineering group for specific lift approvals.
- Advise that lifts or scaffolds should not be operated at the edge of the installation at any time.
- Inform the carpet tile installer of the potential for squeaks if excess adhesive is applied between the panels and that it is imperative that the adhesive is dry before the carpet tiles are placed to prevent oxidation of the galvanized surfaces.
- Inform all trades the torque limits of the TecCrete fasteners (Max of 40 in-lbs) and the proper bit sizes. Post torque drawing exhibit A (located on previous page) around job site. **All screw guns that are used for access floor installation must have a torque limit setting. Impact drivers are not recommended.**
- Make sure enough panel lifters are available so panels may be placed and removed properly and inform other trades of the proper method of lifting and replacing the panels.

5. Determining the Start Point

Figure 1A shows a typical starting layout in the corner of a room situated along the longest wall.

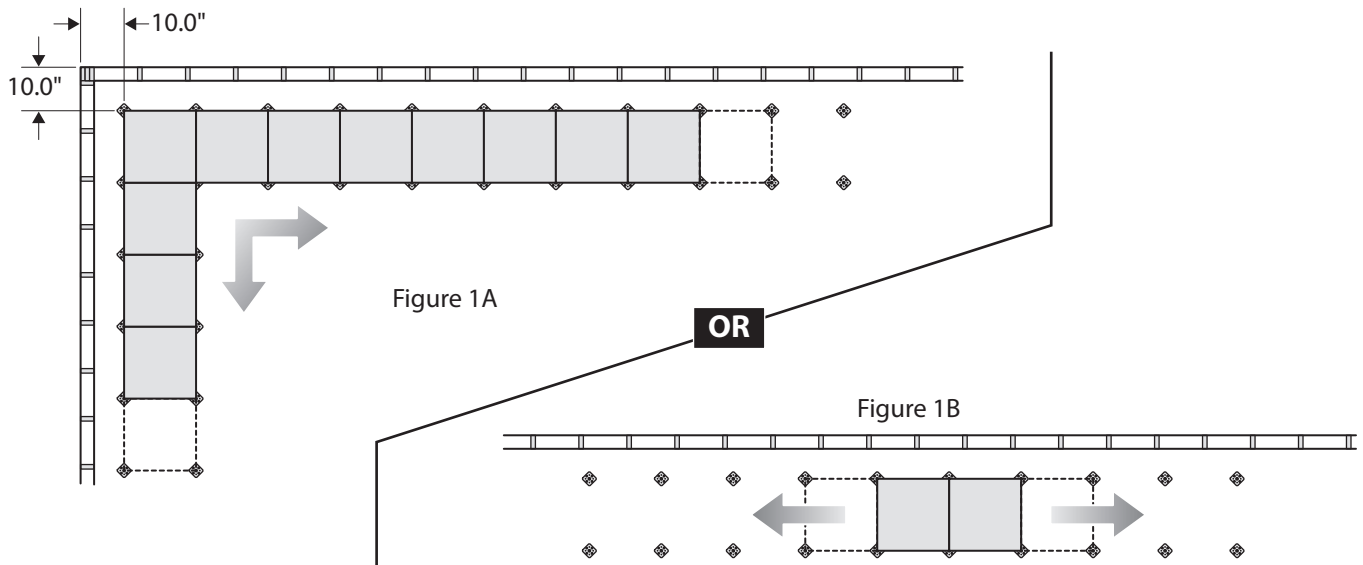

This point may not be desirable due to design requirements to have the module lines match the column lines, the ceiling grid lines, or if the room has a run of 50 panels or more. Long runs (50 panels or more) should be minimized by locating the start point in the middle of the room. This will halve the growth or shrinkage that may result in the installation if it were started in the corner. **Figure 1B** shows a middle start point also allows two installation crews to work away from each other and continue the installation in a progressive manner.

Check for the width of the wall cuts by measuring the total length and width of the room. Verify the distance from the nearest even module (full panels) distance. It is recommended to use a 6" or greater width cut panel at the perimeter. You can then do one of the following operations to the remainder distance:

*Subtract 6" for a minimum cut panel
(or)*

Divide the remainder by two for an equal cut panel dimension

The result provides you with the distance from the wall to the center line of the first pedestal. If you are lucky enough to have square and straight building walls, full panels may be used at the first pedestal line to minimize cut panels

Example: Room width is 123'-8"; the nearest even module is 122'; remainder distance is 1'-8".

*Subtract 6" yields 1'-2" for the wall to start point dimension
(or)*

Remainder distance is 1'-8" divided by two yields 10" from the wall to the start point.

Working from the column center lines of the building requires measuring the distance from the column center line to the walls. All dimensions must be six inches larger than the nearest even module distance. If you must change the start point, be sure to get the change approved in writing by the General Contractor and convey the new start point to the other trades.

6. Elevation Checks and Slab Variance

Starting the installation requires that the start point and starting elevation be determined in order to make sure the building surfaces are met, that the layout does not include cut panels at the walls or columns less than 6" wide, and that the pedestals supplied for the job can adjust to the heights required. Make several height measurements of the slab condition at various locations, especially at the center of bays, at columns, at the exterior walls, and between the columns. Once these measurements are made, the elevation required at the start point is determined in cooperation with the General Contractor and a permanent bench mark is established on a column for reference. Finished floor heights above 6" typically have an adjustment range of +/- 1". Lower floor heights have reduced adjustment range, as little as +/- 1/4" at 4" finished floor height. If the height range required is more than these adjustments will accommodate, you will have to do one or more of the following:

- a. Order some pedestals of various floor heights;
- b. Have the low floor areas filled;
- c. Allow the floor installation to follow the sub floor; or
- d. Order special pedestals with increased adjustment range or cut the pedestal bases.

If field cutting the pedestal tubes to allow a smaller finished floor height, make sure that the end of the tube is cut square. Angular tube ends will cause the pedestal head to rock. If there are conflicts, make sure the General Contractor knows about them and will have the problem addressed. Please keep in mind that most specifications have standard allowances for flatness of the finished floor installation. Typically these are 0.062" in 10 feet and 0.125" over the entire installation. Deviations from the specification requirements will require approval from the General Contractor, Owner, and/ or the Architect.

7. Cleaning the Sub floor

The access floor materials will completely cover the sub floor once installed. Before this happens, the sub floor should be thoroughly swept and vacuumed to remove construction debris, water, and surface dust. This is important in spaces that use the access floor plenum as an air distribution duct.

8. Establish Square Lines

Along the longest room dimension, stretch the chalk line through the start point and anchor at an equal distance from the wall or column at the other end of the room and snap a chalk line on the floor.

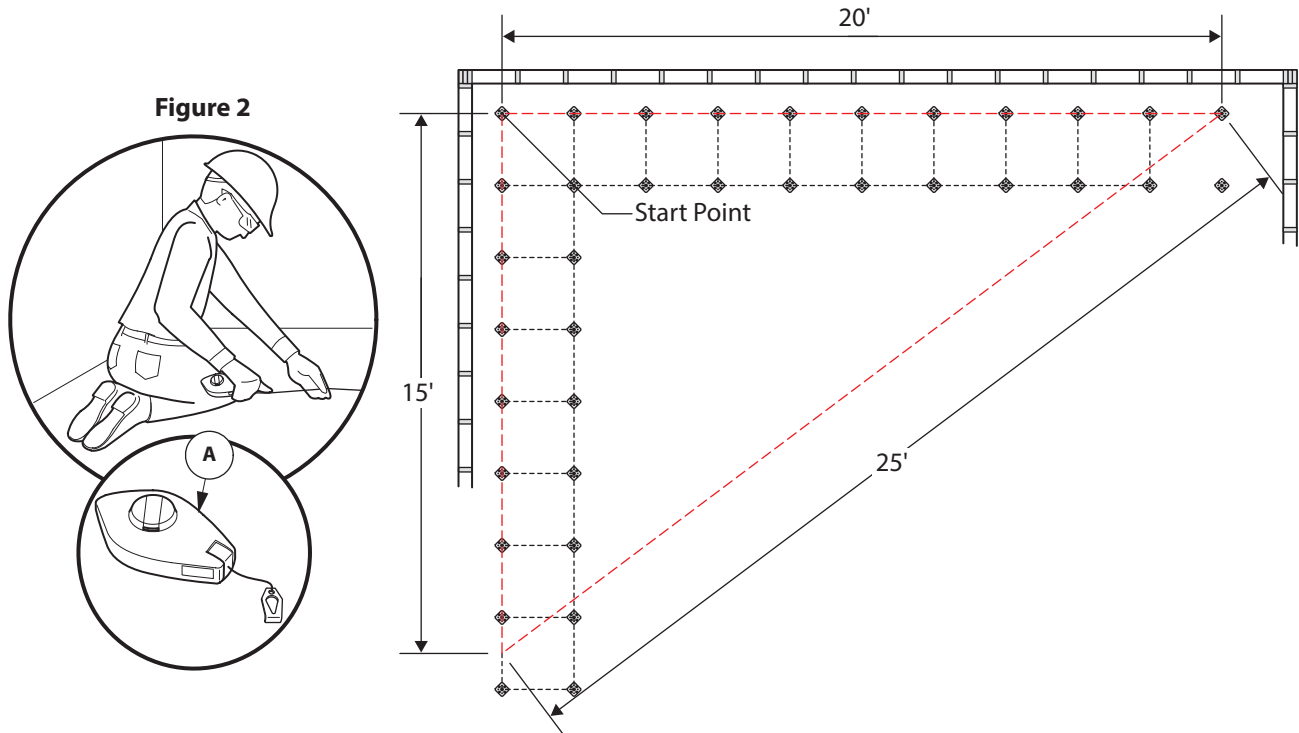

Square the dry lines by using the 3-4-5 measuring technique as shown in **Figure 2**. Measure out 15 on the chalk line from the start point and make a mark on the sub floor. Next, measure out 20 from the start point along another line at a right angle to the first chalk line, and strike an arc on the floor with a pencil. Then measure 25 from the 15 mark on the chalk line and make an arc with a pencil to intersect the first arc. The intersection of the arcs determines the point that the second chalk line must pass through. Anchor the chalk line through the arc intersection and the start point, and then snap a second line. The chalk lines are now square and establish the edges of the first row of full panels in each direction. Double check the dimensions for squareness and the layout against other features of the building to be sure the square lines are running consistently with the building. Make the 3-4-5 dimensions as long as possible to increase the accuracy of the square. Any multiple of 3-4-5 will work as well (such as 15-20-25 as shown in **Figure 2**). The suggested laser will also square an area by positioning the laser vertically. Be sure to check the square created with the laser by measuring to ensure the accuracy of your installation. Erect the dry lines 1/2" above the finished floor height directly over the chalk lines as a guide to locate the edges of the access floor panels as shown in **Figure 3**. Make sure that the lines are square. It is impossible to fix an out-of-square condition after installing a large section of floor.

NOTE: Locate dry lines (B) 1/2" above finished floor height directly over chalk lines (A).

Figure 3

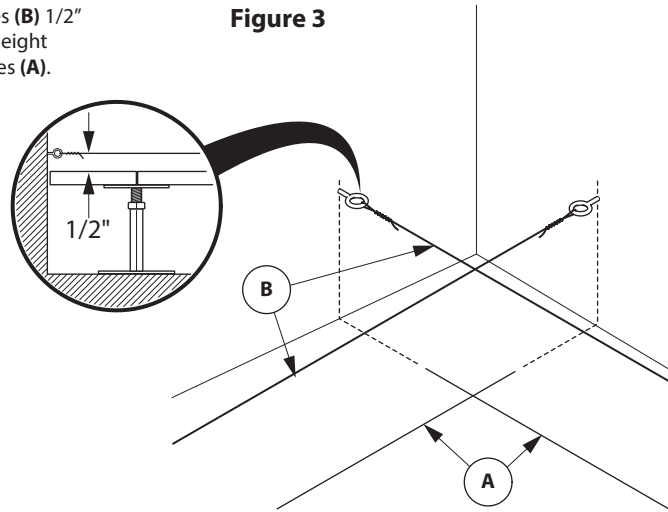

9. Install the Basic ELL

Finally you are ready to install the first pedestals, stringers, (if required) and panels in your new installation. Use the laser and leveling bar to adjust two rows of pedestals along each dry line. Place the panels on the pedestals and check for levelness with the two-foot level. Install the panels along each dry line making sure the pedestal center lines are aligned with the string and the system is staying on module length down the row. Install field pedestals first and go back to fill in the perimeter later.

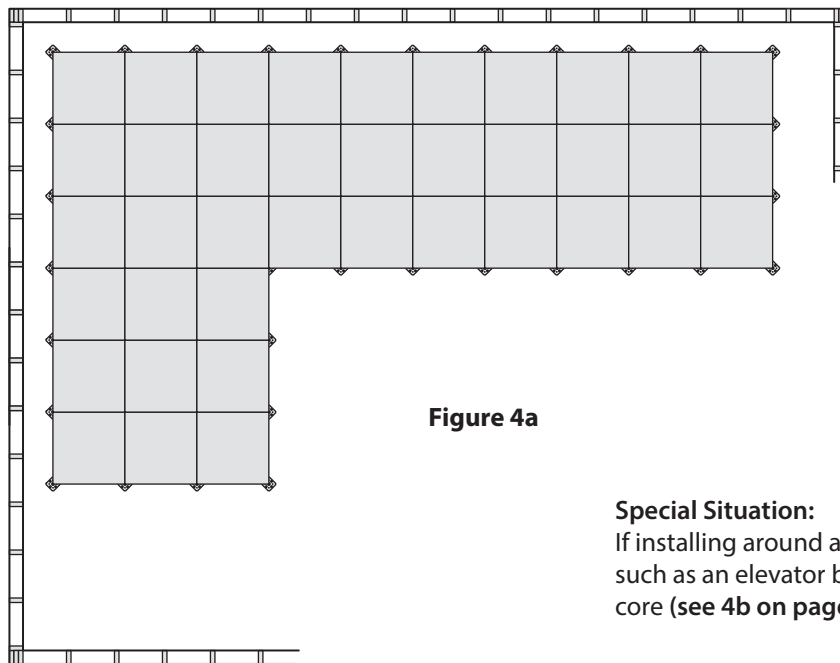

Figure 4a

Special Situation:

If installing around a center obstruction such as an elevator bank in a building core (see 4b on page 15).

Access floor panels are slightly undersized from the 24" installation dimension to allow for a small gap between panels during the installation. This gap allow for easy exchange of panels after the job is complete, reduces noise created by panel and understructure interference, reduces damage to the edge of panels during installation, and makes it easier for the installer to stay on module during the installation process. The initial rows establish the spacing of the entire installation. Check that the panels are installed on the module marks as the installation progresses. This is especially important if the job site is located in cold climates. Recheck the squareness after the first row is installed. Repeat this procedure for the next two rows of panels, continually checking spacing, squareness, height, alignment with the dry line and level as shown in **Figure 4b**.

It is important to prevent other trades from working on or around the first few rows of panels to ensure that the system is not knocked out of square at this early stage. Demand that no one walk on or work in the area of the installation start point for at least 48 hours. This will allow the adhesive to set firmly enough so that the position of the floor system will not readily move. It is advisable to check the installation at the beginning of each day for squareness during the initial installation process.

After three or four rows of panels are installed along each dry line, it is now time to install the cut panels at the walls as shown in **Figure 5** below. Measure, cut, and shim the cut panels as required. The purpose for installing the cut panels at this point is to provide a brace against which the remaining installation may proceed. If shims are used to account for wall variation, do not force the shim so much that the installation moves from the dry line. A snug fit is all that is required. Adhere the shim in place with pedestal adhesive and remove the excess shim material after the adhesive has dried. A square and firm back bone now exists to complete the installation.

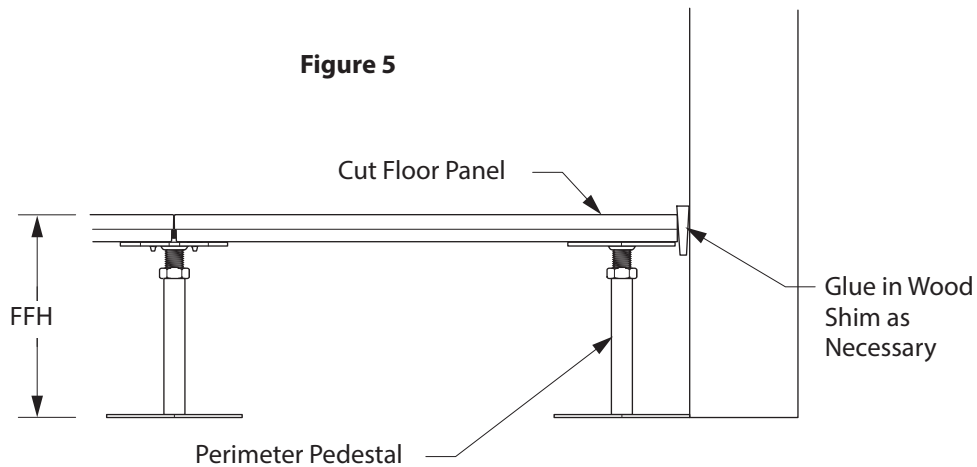
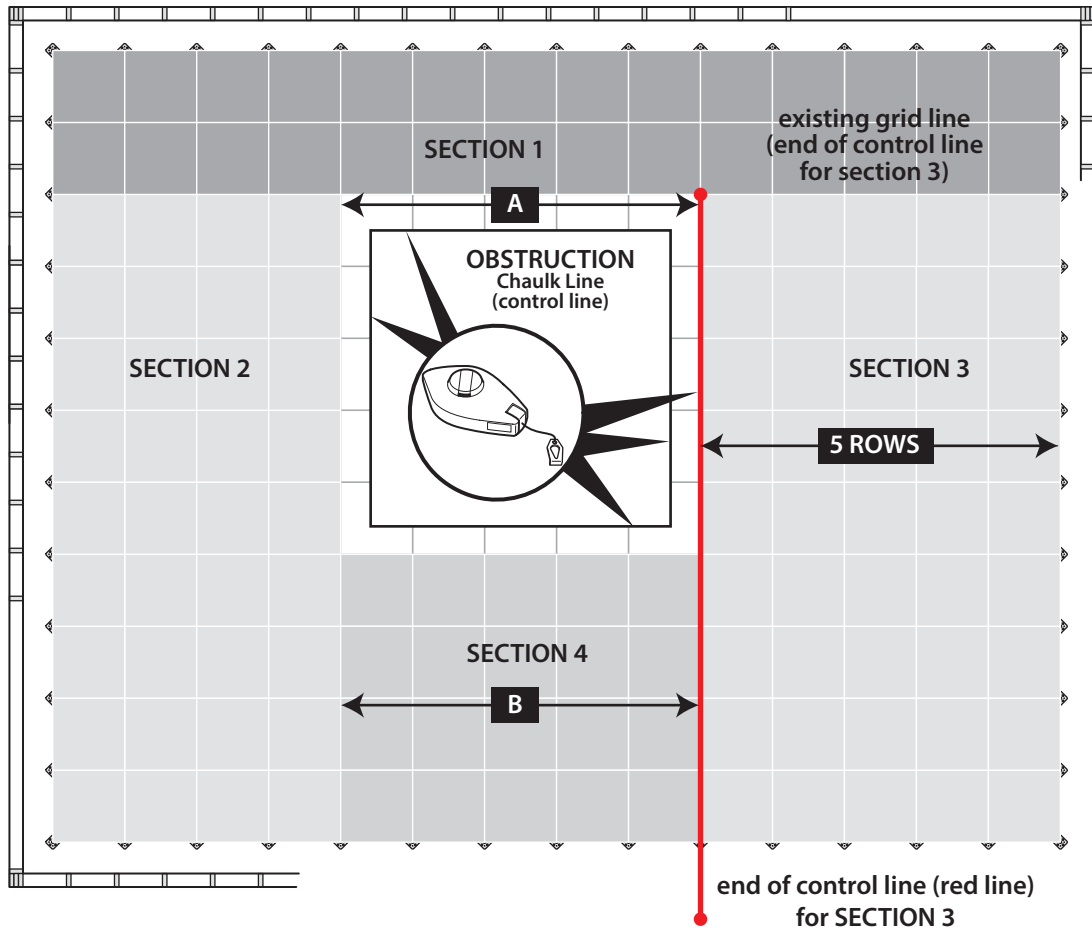

Figure 4b



Panel installation around large center obstructions

The objective here is to wrap a continuous rectangular frame around the obstruction that will be square with the floor that you've already installed. After a continuous frame is constructed, you will install the cut panels around the obstruction. The frame will be installed in four sections (see Figure 4b). Notes: The obstruction may not be square to your frame - but this condition will be compensated for when you install the cut panels. It is best if the frame is 5 panels wide on all sides, but if the obstruction is closer than 10 feet to a wall you will not have a 5 panel wide section on that side.

The panels used to fill this area should be staged from the same delivery group to complete the entire core area to reduce variation in the size of the panel. The core wrap should be completed as soon as possible.

1. Installing Section One

Install understructure and full panels as close as you can to the side of the obstruction that you first approach.

2. Installing Section Two

Install understructure and panels along an adjacent side of the obstruction - as close to the side of it as you can come with full panels. The adjacent side that you choose is the one that faces the other leg of your original 'L' section.

3. Installing Section Three

The next step is to construct a parallel section of floor on the other side of the obstruction (opposite of section 2). To do this you will snap a chalk control line on the sub floor that is parallel to the edge of section 2 (red line in Figure 4b). This will be your control line for installing section 3. Building this section of floor parallel to the edge of section 2 is critical.

3.1 To lay out the control line

1. On the north side of the obstruction, measure the distance from the edge of section 2 (line A to the nearest grid line that exists on the opposite side of the obstruction (the grid line of the floor that you've installed so far).
2. Approximately 10 feet beyond the south side of the obstruction, measure the same distance from the edge of section 2 (line B) and mark the other end of your chalk line there.
3. Snap your chalk line between the end of the grid line of section 1 and the mark you just made. This is your control line for section 3 (see red line in **Figure 4b**).

3.2 Installing Section 3

Position a row of pedestals on the control line, using it as a centerline for the pedestals. Install at least five more rows of pedestals parallel to the control line pedestals so that 5 rows of panels can be installed. No more than 5 rows of panels should be installed at this point it may be necessary to move this entire section slightly if it is too close to (or too far away from) the adjoining section on the south side of the obstruction that you are about to create (section 4). Make sure that your pedestals stay centered on your chalk control line.

4. Installing Section 4

Once section 3 extends five panels beyond the south side of the obstruction, you can begin to fill in the gap between sections 2 and 3. This will be section 4.

When the entire frame is 5 panels wide on all sides and there are no gaps at the seams where the sections meet, you are ready to install the cut panels around the obstruction. After installing the cut panels you can continue with the remainder of the floor.

10. Adhesive Coverage

Haworth Architectural Interiors standard specifications and many job specifications call for a minimum pedestal turnover performance of 1000 in-lbs. These results will generally be obtained within a reasonable margin of error using a standard pedestal base and factory applied adhesive. This is based on several factors which must be complied with:

- The pedestal bases are completely covered with adhesive. Minimum coverage recommendations - adhesive applied to the bottom side of the base plate.

Base Size	Envirotech 105	Sealbond 95	Polyped
4" x 4"	40 g	30 g	25 g
5" x 5"	50 g	37.5 g	38.4 g
6" x 6"	90 g	67.5 g	55.3 g

- The adhesive is fully dried. The drying time is variable due to job site conditions.
- The job site conditions conform to the recommended installation conditions.
- Tested concrete sealers have been used and the sub floor is concrete.
- The concrete is clean, dry, and structurally sound.
- Seismic specification requirements may have higher turnover moments and will require consultation with the Engineering Department for the proper pedestal base and attachment method (adhesive and/or mechanical anchors. If some of the above conditions have not been met, lower turnover moments may result. It is advisable

to place trial pedestals well in advance of installation time to verify adhesive compatibility, especially if an unknown sealer has been used. Bonding to sub floors other than concrete should be tested on an individual basis by the installer or customer on the job site to verify performance. Please refer to [Chapter 6](#) for instructions on field testing the pedestal bonds.

NOTE: Evenly distribute adhesive to bottom of pedestal (C). Continue this process staying no more than one hour installation time ahead of the panel layer.

Figure 6

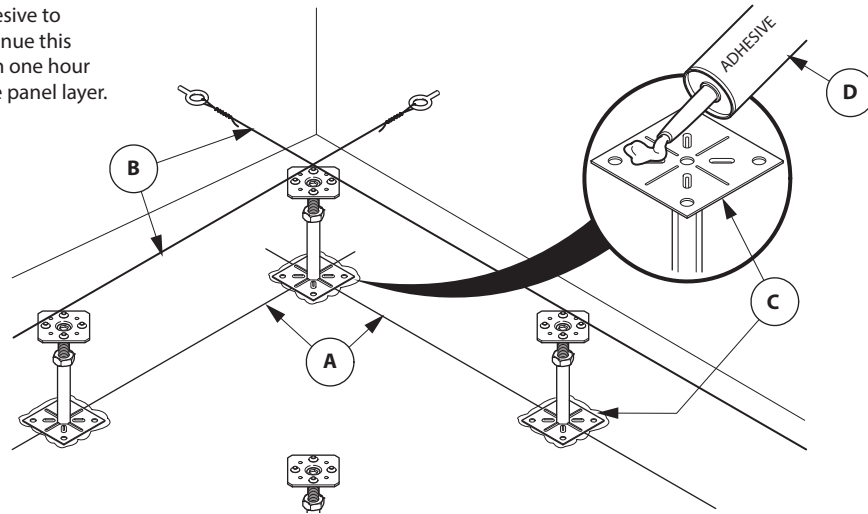

11. Filling

The installation of an access floor is a progressive operation. Start off of the basic ELL and finish the room across to the opposite side. Do not attempt to pre-install the understructure and later fill in the panels. The installation will be out-of-square, have gaps between the panels, and may not even allow the panels to be installed. Do not attempt to start the installation from two separate locations and meet in the middle with even panel dimension and matching grid lines. Access floor systems grow and shrink at different rates depending on the method the panel layer uses to place the panels. Independent start points will result in cut panels and/or uneven grid lines.

IMPORTANT: DO NOT RANDOMLY INSTALL PANELS.

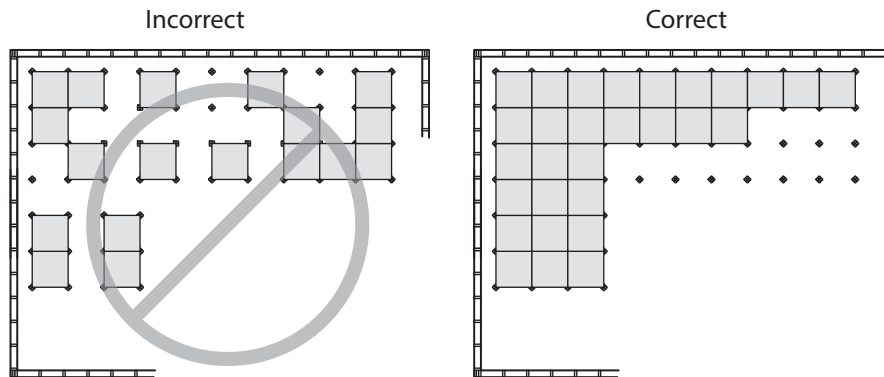

12. Leveling

There are three elements used to level the access floor pedestals: the laser, the leveling bar, and the installer. It is easier to control the elevation of the floor system if one person does the leveling for consistent application of the laser beam on the target. Two leveling people will always read the mark slightly different resulting in more effort by the panel layer to control rocking panels. The laser is used to establish the elevation of the primary pedestals which are located at the length of the leveling bar (10 feet for this example).

Figure 7

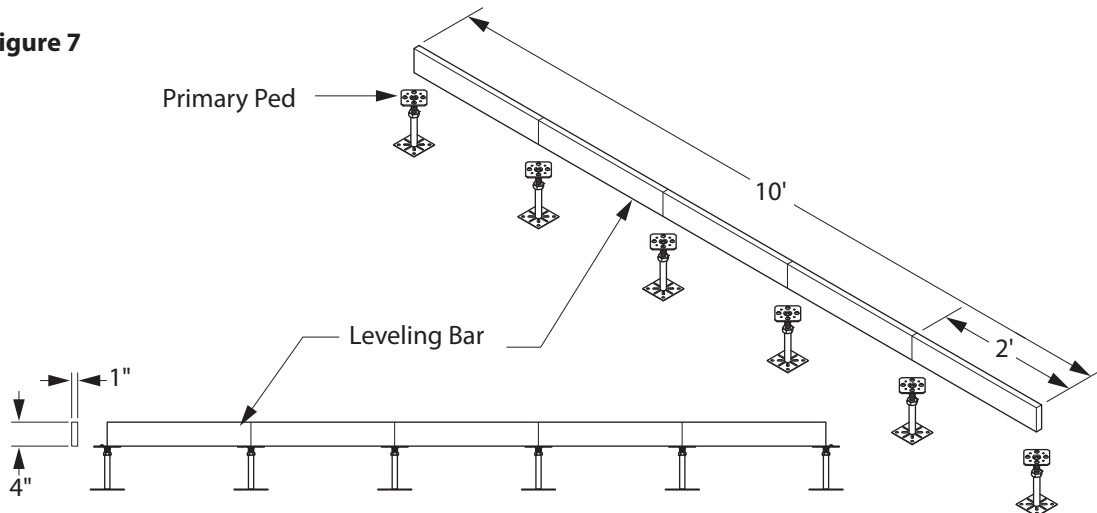

Some variation in level readings will always occur making each primary pedestal slightly different in height from each other. The 10' leveling bar is used to taper these differences over a 5 panel width as shown in Figure 7. The leveling bar is usually made from aluminum to minimize its weight. The dimensions shown can be changed depending on the length of the bar. After leveling two primary pedestals, place the leveling bar on top of them and adjust the secondary pedestals up to the bottom of the leveling bar at the secondary pedestal location marks on the leveling bar.

The height adjusting nut on the pedestal head has a small bump to prevent the pedestal nut from changing adjustment as the floor is used (see figure 8 below). This bump is to be located to the side of the pedestal tube so the nut sets flush with the end of the pedestal tube as shown in Figure 8. Move the laser as infrequently as possible, set the laser ahead of the installation and install up to and away from the laser leaving a small island of uninstalled panels around the laser. Try to stay within 50 feet of the laser to minimize the variation in the width of the laser beam. Apply the pedestal adhesive to the bottom of the base, set it firmly in place and rotate the base on the floor to evenly distribute the adhesive across the bottom of the base, eliminating excess adhesive under the base establishing contact with the sub floor. Continue this process staying no more than one hour installation time ahead of the panel layer. This will make sure the pedestal adhesive is still pliable for the panel layer to locate the pedestal when the panel is set in position.

Figure 8

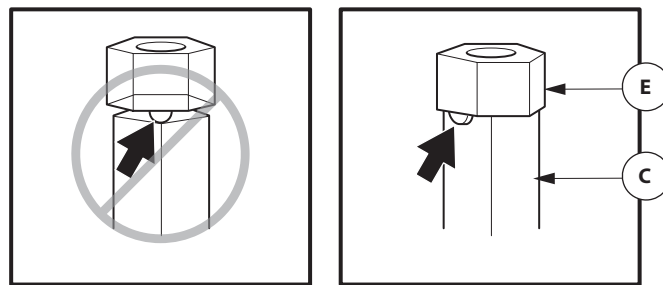

NOTE: The height adjusting nut (E) has a bump to prevent the pedestals (C) from changing adjustment as the floor is in use.

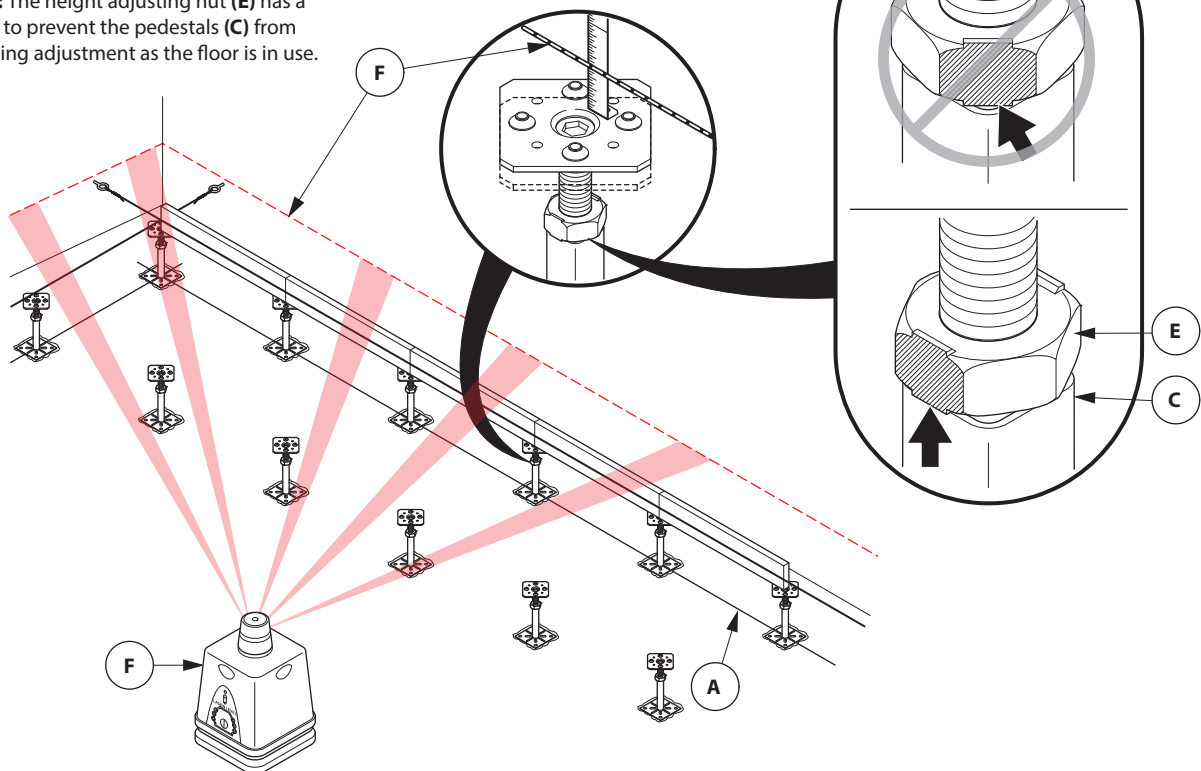

13. Tapering the Finished Floor Height

Tapering the finished floor height is sometimes required to meet various building features. The procedure to taper the floor and prevent rocking panels requires planning ahead and careful adjusting of the pedestal elevation. Measure the distance from the installation point to the building feature which the access floor must meet. Divide the distance by the length of the leveling bar you are using to find the number of primary pedestals from the installation to the feature. Divide the total height change required by the number of primary pedestals. This result provides the basic increment that the primary pedestal heights must be changed to mate with the feature. Using the laser, level each primary pedestal to the height required adding the height change to each primary pedestal. Use the leveling bar to adjust the secondary pedestals to the bottom of the bar. The floor will now slope gently to the building feature. Approximately 1/8" height change for every 10' can be achieved using this method. Make sure to get approval from the General Contractor to slope the floor in this manner; you may exceed the allowable overall height change indicated in the specification.

Example: *The doorway at the far end of the room is 3/8" higher than established floor height and is 32' away. 32'/(10' leveling bar) is 3 primary pedestals between the installation and the doorway. 3/8"/(3 primary pedestals) is 1/8" rise for each primary pedestal. Set primary pedestal #1 at +0.125", primary pedestal #2 at +0.250", and primary pedestal #3 at +0.375". Use the leveling bar to adjust the secondary pedestals establishing the slope required to meet the doorway.*

14. Installing Stringers

The stringers (G) may now be attached to the pedestal heads (C). When installing the stringer screws (J), be sure not to over-torque the screw (a maximum of 40 in. lbs. is recommended). If the stringer profile bulges around the screw head or the end of the stringer flares, the torque setting is too high on your screw gun. Bulges and flare in the stringer may cause interference with the panels preventing the panels from meeting and creating installation noise. Maintain the squareness of the heads with the stringer and module lines. Twisted heads will force the panels out of square creating gaps between panels and rectangles at the intersection of the panels. If you are using the 4' stringers and have a fixture used to attach the heads to the stringers, the stringers will already be in place when you level the pedestals. The 4' stringers will also act as a form of a leveling bar to adjust the pedestals. Load bearing 450 lb. stringers use 1/4" - 20 x 1-3/4" screws. The load bearing stringers (G) are offered in either 2 or 4 foot lengths. The load bearing stringers (G) are attached to the pedestals (C) diagonally across the pedestal head. Do not use the domed holes for the load bearing stringers. They are not on the same center spacing as the holes located on the diagonal.

Take care to ensure that the stringer is sitting flat and square on the pedestal head before fastening to the pedestal head. This could cause noise if not properly installed.

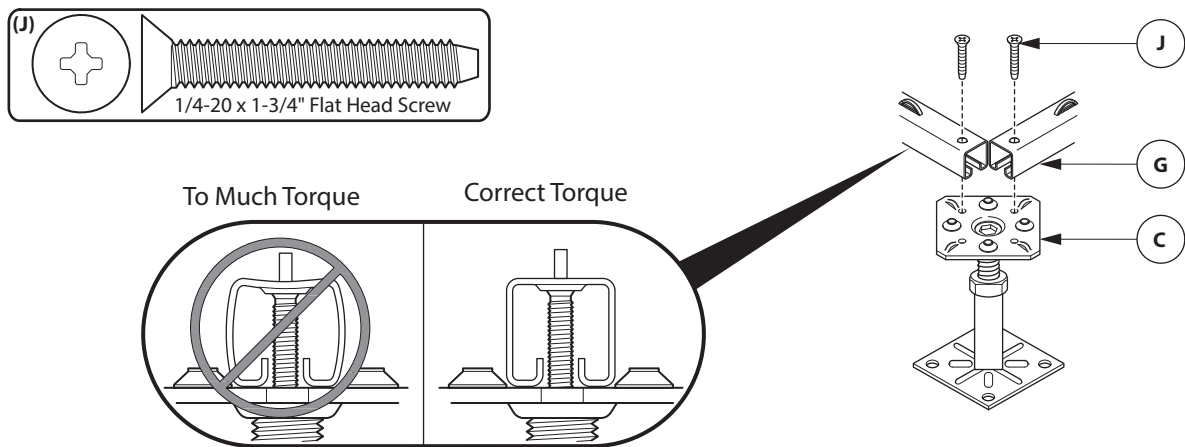

15. 2 x 2 Stringers

Two-foot stringers provide the easiest access to the underfloor cavity if new equipment must be installed under the access floor. Stringers and panels adjacent to the work area do not have to be removed as with the longer stringer modules. Two-foot stringers require more effort to maintain the floor squareness during the installation process due to the greater number of joints in the stringers. Assembly of the stringers to the pedestals is usually performed at the point of panel installation. See figure 10 below.

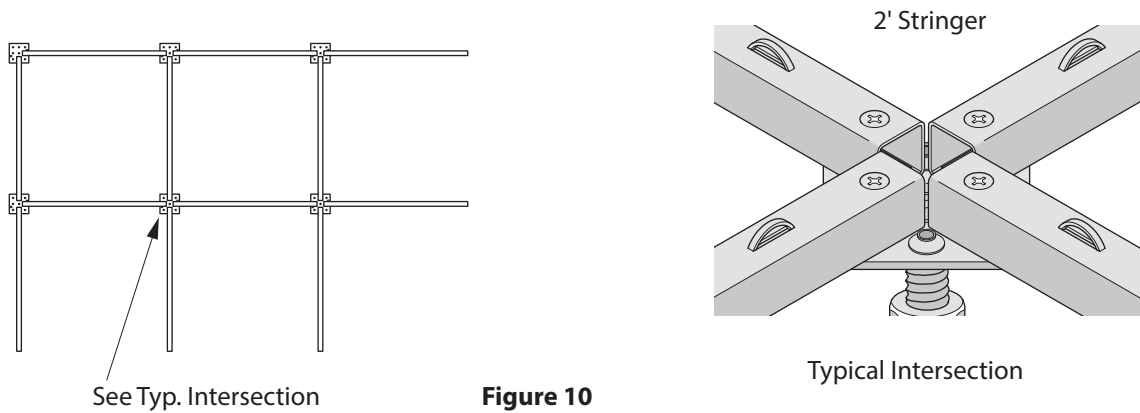

Figure 10

16. 4 x 4 Stringers

Four-foot stringers are assembled using a basket weave pattern. Each pedestal head has a 4-foot stringer attached at the midpoint of the stringer length. This system provides superior lateral load distribution, maximum vertical load sharing, and an aid to a square installation. Four-foot stringers complicate underfloor access. A 6-foot wide corridor of panels and stringers must be removed to clear a one-module wide path. (See figure 11 below)

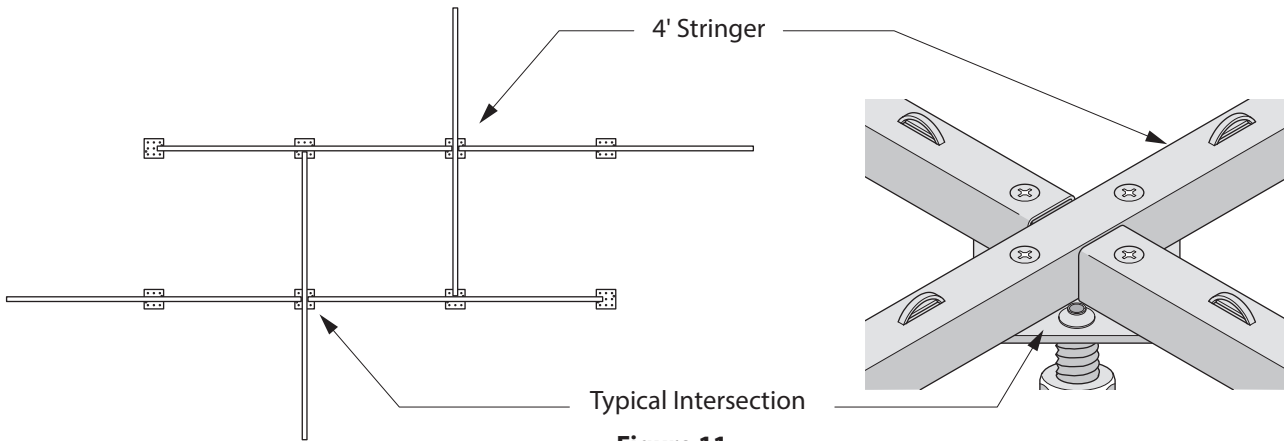

Figure 11

17. Installing Stringers at Cut Panels

Stringers may be installed perpendicular to the walls, curbs, etc. by cutting the stringer to the length required for the application. Stringer holes are then drilled in the top of the stringers at the required location and a countersink is formed using a forming tool and a hammer. If stringers are required to be installed parallel with the wall, the perimeter pedestal head and the stringers are used parallel with the wall.

18. Installing Stringers at a Wall or Obstruction

The stringer should not extend beyond the edge of the pedestal head more than 3 inches without additional support.

19. Grounded Stringer System

Grounding screws are required if the panel to pedestal resistance must be 10 ohms or less. The grounding screw creates contact points between the panel and the pedestal head to create a ground path. We recommend using grounding screws in place of all stringer screws to ensure a fully grounded system.

4.2 Placing Panels

The final operation in the basic installation process is to place panels on the pedestals. Be sure to check for panel alignment, squareness, rockers, pedestal alignment, and fine adjustment of pedestal height. Placing panels is typically performed by the most experienced installer on the crew, as the panel layer will control the quality and function of the final installation. The following are some of the key things to look for when installing the panels.

Place field panels first. Install panels at the perimeter, curbs or obstructions later. Start with the largest cut panel first. All cut panels should be measured and cut to fit specific locations.

NOTE: The height adjusting nut has a bump to prevent the pedestals from changing adjustment as the floor is in use. See "Figure 8" for details.
Screws should be torqued to 40 inch-lbs Maximum.

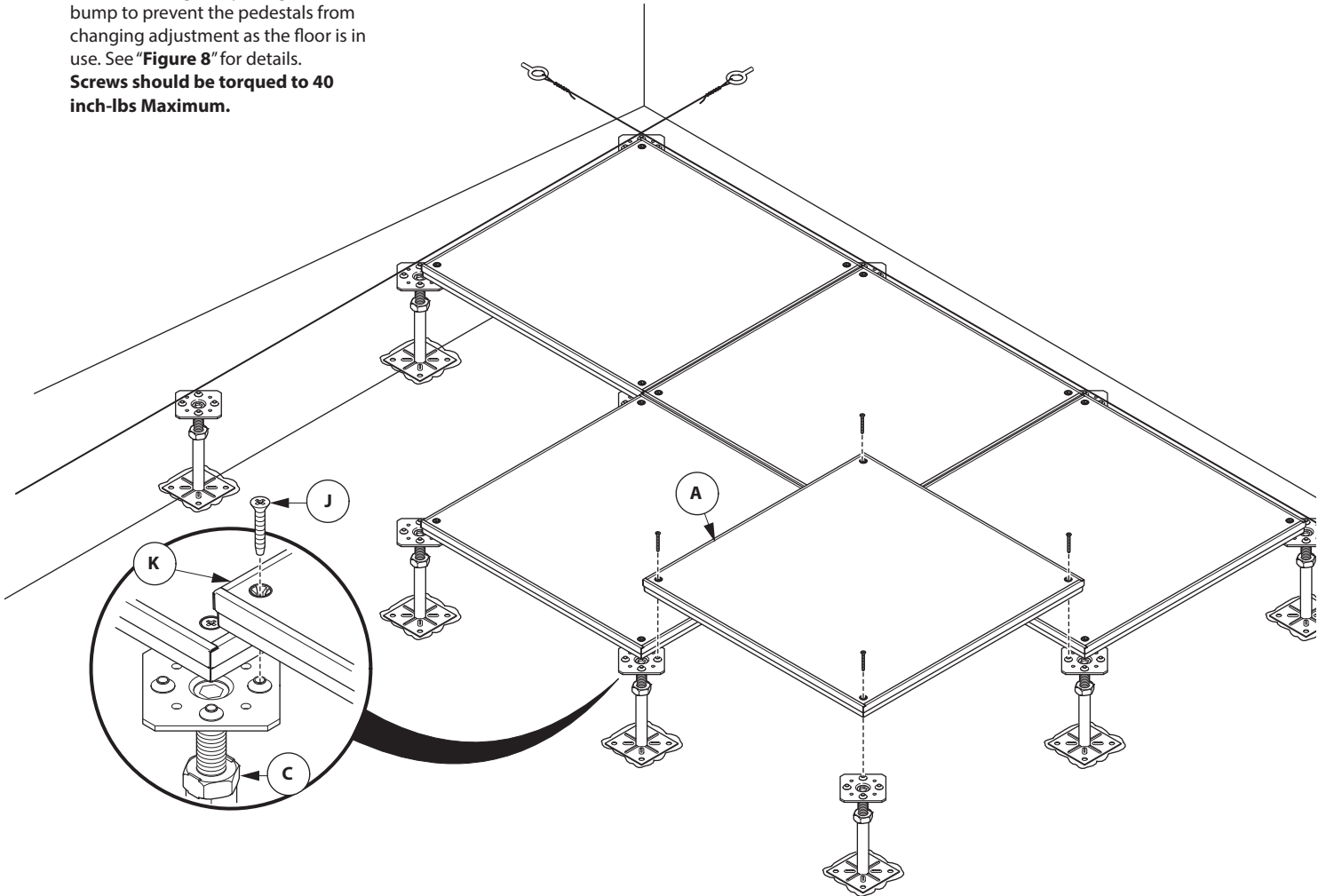

1. Panel Spacing

Module lines should be straight and square. Do not force the panels together. A gentle nudge against the adjacent panel is all that is usually required. This helps to maintain the clearance between panels. Remember the panels are slightly undersized to allow for small clearances between panels and maintain the basic panel module size. If the initial rows of pedestals and panels are properly spaced, visually checking the module lines for straightness will help to maintain the panel clearances.

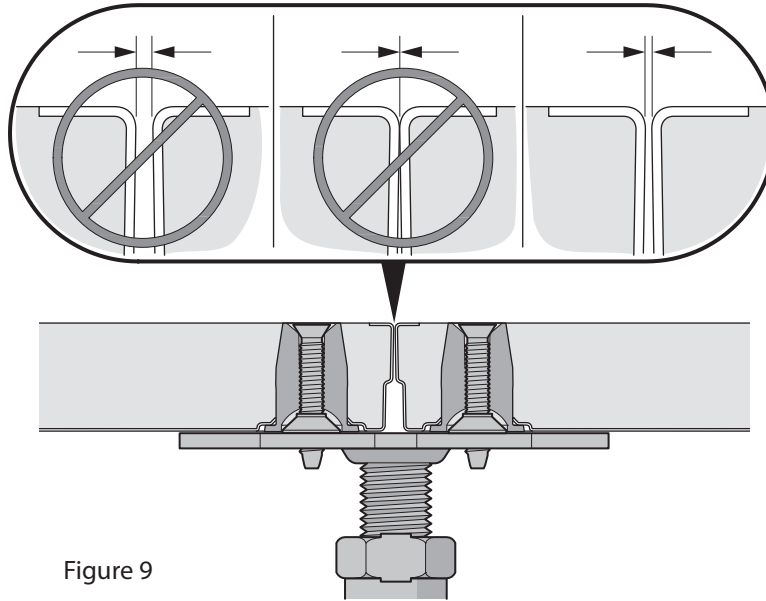
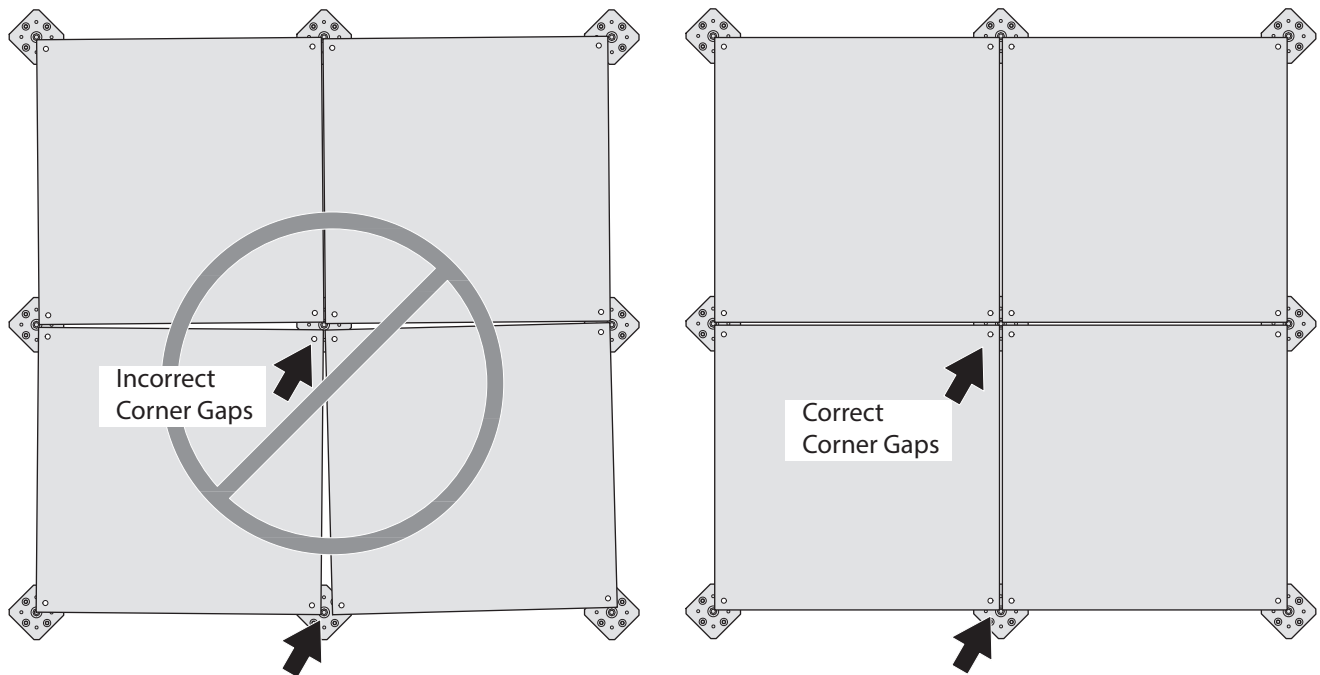

Figure 9

2. Corner Gaps

Corner gaps are openings that can appear at the four corners of panels over the pedestals. They indicate the installation is not square or the panel may be out of square. Generally, these appear gradually during the laying of the panels. You must back up and reinstall the panels where the openings have developed. Continuing to install will make the gaps bigger and the module lines will continue to develop larger steps. Check the dry lines and the squareness of the pedestal heads.



3. Adjusting Pedestals

All efforts to resolve rocking panels should be made before adjusting the pedestals. No more than one or two “clicks” (1/4 turn) should be necessary. If you notice that you are adjusting a lot of pedestals, check to make sure the elevation with the bench mark that was established in the beginning is correct and verify with the leveling installer to see if they are leveling consistently. It is easy to force the installation height up or down. You may have to back up and find the spot where the wave in height developed.

4. Low Profile Pedestals

This special application of the corner-lock pedestal system is designed for applications where the access floor height is restricted due to the limitation of the ceiling to floor height dimension of the building. There are several special needs that must be observed using this system.

1. Because of the low finished floor height (3"-5") the under floor cavity is very small. This may require constant monitoring of the under floor clearance to accommodate any wiring devices which are to be installed under the access floor. Some wiring devices may have to be positioned above the access floor to minimize this concern.
2. Low profile pedestals have a reduced adjustment range (+/-1/4" to 3/8") depending on the floor height. This may mean some or all of the following conditions may exist:
 - Several pedestal heights may be required to maintain a level access floor.
 - Extensive sub floor elevations will be required, or
 - The access floor may need to follow the condition of the sub floor maintaining a constant plenum height.
3. It is advised to make all adjustments before applying the adhesive to the base to avoid adhesive transfer to hands, tools, and finishes.

5. Edge Height of Panels

Check adjacent panels to see if the panels edges are level. Panel to panel edge steps indicate the panel is not flat, the pedestal is tilted, or there is debris under the panel. Check for each and correct as necessary. **(See Figure 10)**

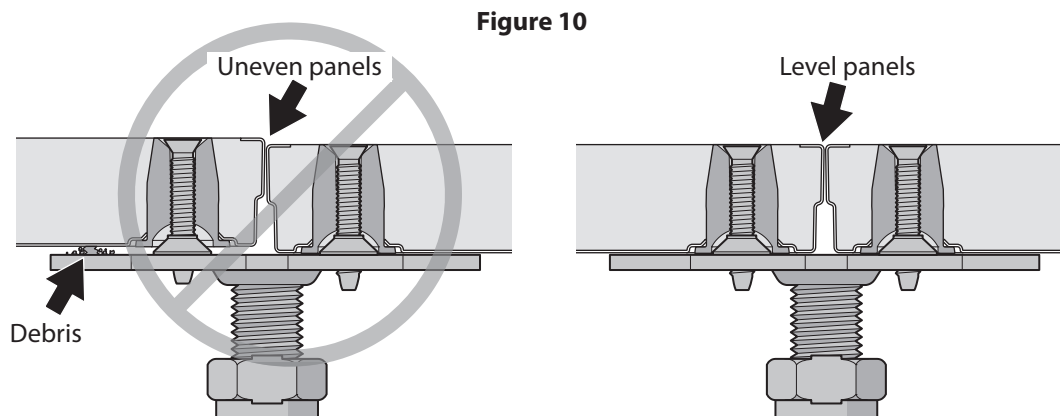

6. Square and Plumb of the Pedestal

Typically the pedestal must be shifted slightly to conform to the panels when the panels are placed in the installation. The pedestal base should be firmly positioned on the sub floor, the pedestal head plumb with the pedestal base, and the pedestal head square with the panel module lines. Using a mallet on the pedestals to force the panel against the adjacent panels will cause the system to move out of square. An out of plumb pedestal, as shown below on Figures 11 and 12 will cause unnecessary movement in the understructure and result in a noisy installation. Additionally, a mallet blow can also cause the installation to be excessively tight on corner-lock and bolted grid systems. The mallet will force the parts together and the parts will be held in place due to the friction provided by the fasteners in the panels and stringers. Look for the panel module lines to be straight, the center of the stringer top or pedestal head to be positioned at the top edge of the panels, and the module spacing has consistent dimension.

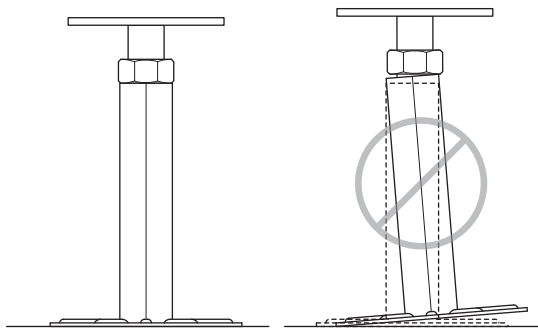

Figure 11

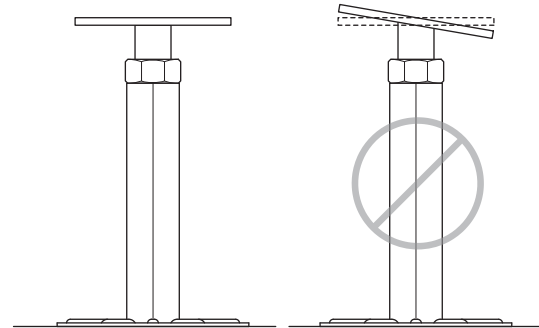

Figure 12

7. Working off of the Access Floor Installation

The presence of conduits, pipes, and construction debris sometimes makes it very difficult to transport skids of panels over the job site and work from the sub floor. It may be easier to deliver material to the installation area by carrying materials over the access floor installation. When working on the installation, observe the following habits.

- Do not store the access floor materials in one location. Spread the load out to avoid overloading the building floor.
- Keep the pallet jack and skids away from the edge of the installation area. This will prevent accidental collapse of the floor and avoid injury.
- Schedule the installation and truck arrivals to allow you to install the panels as they are delivered to the area
- Continually check for squareness and straightness of the module lines. This is especially true for free-standing systems. The rolling loads of the skids will cause the installation to spread.
- Allow the adhesive to cure on the base ELL for at least 48 hours or use a rapid cure adhesive.
- Make sure the pedestals are firmly positioned on the sub floor. Loads applied to thick, fresh adhesive can change the height of the pedestal, causing rocking panels to develop.
- Remember you have just encouraged others not to work on of the access floor installation and you don't want to set a bad example. Make sure the area is safe!

8. Use by Other Trades

Inevitably other trades will want to use the access floor immediately after you put the first panel down. Do not allow this to happen. Freshly laid panels can and do shift from their installed position if they are loaded vertically and horizontally while the adhesive is fresh, the perimeter is not cut in, and the free edges of the installation are not restrained. This will detract from the finished quality of the installation in a way that may not be correctable. Excessive gaps between panels, out of square installation, rockers, damage to the panels, and collapse of the floor at the free edge are but a few of the problems which can occur if other workers are allowed to use the floor during the initial set up period. It is recommended that no one be allowed to use the floor for at least 48 hours to allow the adhesive an opportunity to begin curing. It is further recommended that the perimeter cut panels be installed, the free edge of the floor be braced, and the other trades come no closer than four panels from the free edge of the installation with motorized lifts. Heavy carts and lifts may also do permanent damage to the panels. An overlay of at least 1/2" thick plywood should be used to distribute heavy loads if they should occur.

9. Cutting Panels

After the basic installation is finished, the remaining perimeter panels, column cuts, and equipment cuts may be installed. These panels are unique to their locations and typically cannot be exchanged for another location. ALL cut panels should be closely sized so that the cove or straight base will cover the cut edge of the panels. It is also advisable to file or rasp any rough edges to prevent injuries which may result from handling sharp edges. If the walls are not straight, more care must be taken to fit the panels to the contour of the wall to avoid gaps. The perimeter cut panels must be properly supported to maintain the system integrity. Cut panels may be weaker than full panels and their strength depends on the size and type of cut. Supplementary support is required at aisle-way transitions, for example, to support the loads they will be exposed to. Uncovered panel openings are also a tripping hazard. Mark the location of the holes or cover them to prevent accidentally falling into the openings. Please refer to the Cutting Panel Section of each panel type for equipment suggestions and procedures. **(It is recommended that interior cutouts be done at the factory.)**

NOTE: Cut all material in another room to prevent sawdust and debris from entering installation area.

NOTE: All steel edges should be deburred to eliminate sharp edges.

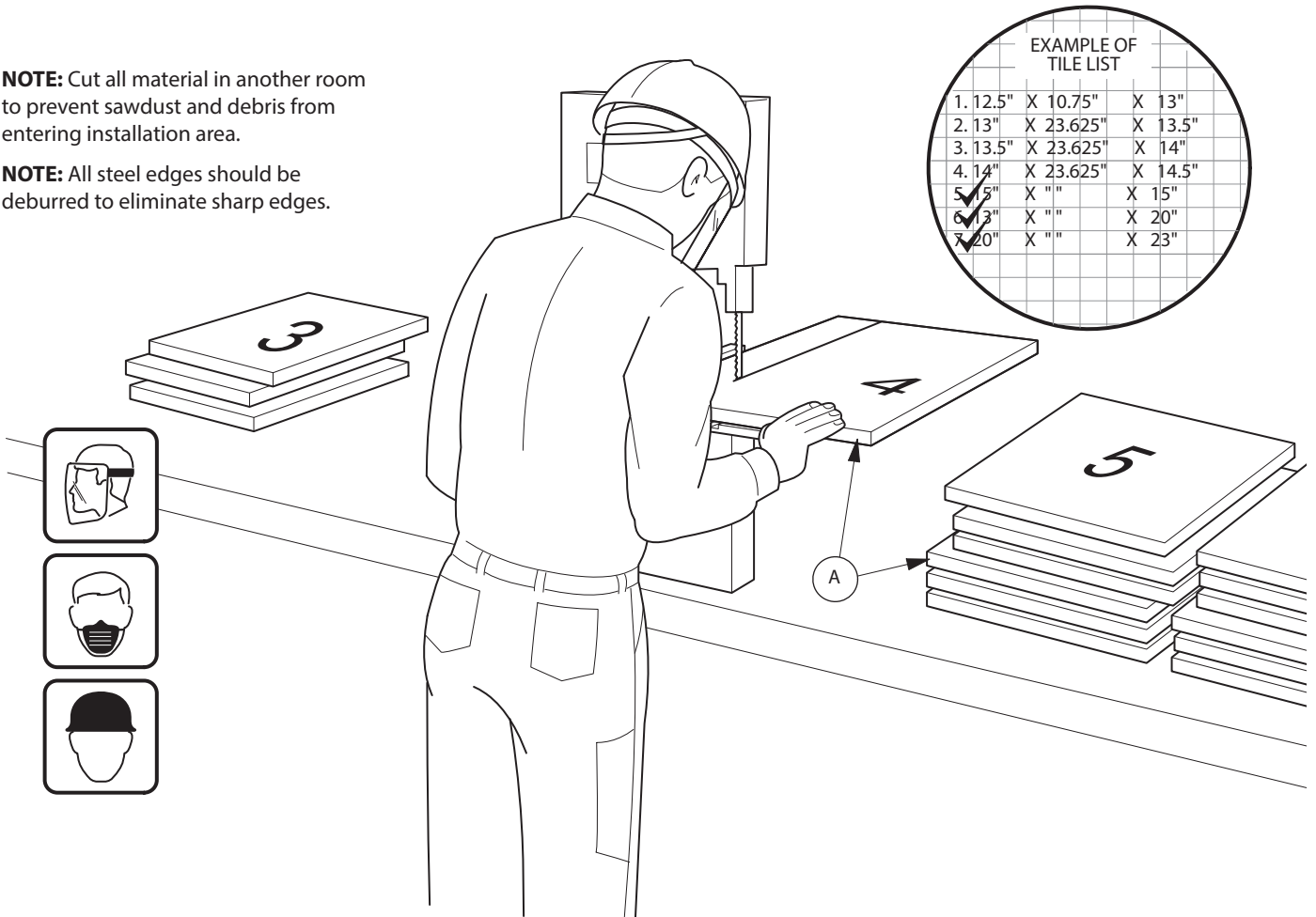

4.3 Trouble Shooting and Final Adjustment

After the basic installation is completed, it will probably be necessary to go over the floor and fix some spot problems. Below is a brief listing of some of the more common problems that could be encountered.

1. Rocking Panels

Rotate the panel 90 degrees. If the rock stays in the same direction, the pedestals need to be adjusted; if the rock changes direction, the problem is with the panel. Check the bottom edges and corners of the panel for damage or debris. If there is nothing visible, set the panel aside to be used as a cut panel at a wall or column.

Check to see if two or three panels point to one pedestal. A low pedestal will cause all the panels to rock toward it. If the pedestal is high, the panels will all rock around the pedestal. The adjusting nut dimple may be on top of the pedestal tube; rotate the nut until the dimple is at the side of the tube or adjust the pedestal to eliminate the rocker. Be sure you have not created another rocker by adjusting the pedestal.

Check for a damaged panel, pedestal head, or tilted pedestal assembly.

2. Corner Gaps

These are openings that can appear at the four corners of panels over the pedestal. They indicate that the installation is not square. Generally, these appear gradually during the laying of the panels. You must back up and reinstall the panels where the opening first developed. Continuing to install will make the gaps bigger and the module lines will continue to develop larger steps. Check the dry lines and the squareness of the pedestal heads.

3. Causes of System Noise

- a. **Dirt:** Particles between the panels and pedestals, panel and stringers, or stringers and pedestal heads can cause noise to be created when the system is loaded. Remove the dirt and protect the area from construction debris.
- b. **Plumb Pedestal:** Tilted or canted pedestals do not transfer the floor loads directly to the slab as they should. The pedestal head or base (or both) will rotate when a load is applied, causing extra movement in panels, and creating noise. Check for either level panel surfaces at the panel corners, vertical alignment of the adjusting stud and pedestal tube, and firm attachment of the base to the sub floor. You will probably have to reposition the pedestal base, slip the head in the stringer, or loosen several panels in a corner lock installation to correct the problem.
- c. **Pedestal Head Rotation:** Pedestal heads may be misaligned and are interfering with the panels or stringers. Remove a panel and look for the pedestal head to be out of line with the panel module lines. Tap the head square and re-tighten any fasteners.
- d. **Adjusting Nut Location:** The locking dimple may be resting up on the pedestal tubes. Rotate the nut off of the tube.
- e. **Vertical Adjustment of the Pedestal:** On systems with stringers or corner lock systems, the panels may not rock when checked because the weight of the panel easily and can pull the head out of the base slightly. When a load is applied, the nut clicks on the pedestal tube. Adjust the pedestal nut to support the head firmly.
- f. **Pedestal Head Square:** If the panels are flat at the corners and the pedestal base is not plumb, this could indicate the pedestal head is not square with the stud. Determine which way the head should be bent and hit the high side just outside of the stud with a large hammer to straighten the head, or replace the head. It may also be necessary to relocate the pedestal base.
- g. **Excessive Vertical Movement:** Check the sub floor for soft spots such as trench covers, bridging, or defective panel. Replace the panel or support them adequately.
- h. **Damaged Materials:** Check all materials for damage and replace or repair as required.
- i. **Carpet Tile Adhesive:** Carpet tile adhesive that has been poured on or rolled out with excessive material can penetrate between the panels. Once the adhesive dries, it is like a rubber band between moving panel edges and produces squeaks. Remove the panel and clean the edges with a utility knife to remove the built-up adhesive and replace the panel.

4. Protection

After you have received the sign off from the Owner or General Contractor, the Specifications may call for you to provide protection for the access floor materials. Use 20-lb Kraft paper or plastic sheeting over the access floor to protect the finishes and the access floor system from construction debris. Tape the sheet seams especially in the main aisle-ways to prevent tripping or unraveling of the sheet.

5. Move-in

During the move-in phase and at any time the access floor will be subjected to heavy rolling loads, the floor must be covered with **minimum 1/2" plywood sheeting** in the path of the rolling loads, depending on the magnitude of the loads. The plywood distributes the weight across a larger area than is covered by an individual wheel or caster. This will prevent damage to panel surfaces and avoid dangerously overloading the floor panels. This procedure should be followed on ramps if they are being used as a conveyance of heavy material over the floor. Generally ramps are intended for pedestrian traffic and should not be used to transport heavy loads without a supplemental overlay.

When using motorized vehicles on top of an access floor, sudden stops and starts and/or accelerations must be avoided. The dynamics of these motions in conjunction with heavy loads could seriously compromise the structure of the access floor. Consult with the Haworth Sales Engineering Dept. concerning specific pieces of equipment.

6. Sign Off by the General Contractor

Once you have completed the installation and have gone through the final punch list process, have the General Contractor sign off on the installation. This is your security against damage by other people and will protect you if a dispute should arise. A sample Sign Off Sheet has been provided for your use on the following page. **(Make sure that this sign off sheet is kept in your job file for reference should a problem occur.)**

On larger projects more than one sign off sheet maybe required. As you complete an area or floor and before turning this area or floor over to the other trades, request that the owner or general contractor sign the form releasing you from that area. At that point it becomes the owners or general contractors respond ability to care for the installed floor.

4.4 Access Floor Installation Acceptance and Sign Off Sheet

Access Floor (Sub) Contractor: _____

General Contractor: _____

Project Name: _____

Contract Number: _____

Area Number: _____

Date: _____

We have reviewed the access floor condition and installation quality of the above project or area and have found it to be complete and in accordance with the Project Specification.

The following exceptions are noted: _____

(signed) Authorized Representative for the General Contractor

5 SCREWS AND FASTENERS

5.1 Panel and Stringer Fasteners

Haworth Architectural Interiors utilizes varying sizes of fasteners for corner-lock panel systems and stringer attachment. The panels and stringers are countersunk to accept specific size fastener heads. Make certain that the correct size fastener is available and is being used to prevent damage and to provide for proper seating of the fasteners. Listed below are the descriptions of the fasteners used in the various systems.

TecCrete 1250 uses 1/4"-20 x 1-3/4" and 2" long fasteners for corner-lock application. These fasteners should not be used to pull the panel or pedestal heads together. Correct out-of-level conditions by adjusting the pedestal nut or repositioning the pedestal assembly. Using the fasteners to pull the parts together can cause the TecCrete corner to crack, pull the fastener through the screw hole, strip out the screw drive or the screw threads. All corner-lock fasteners should be tightened to 40 in lbs maximum. We recommend using a battery powered, adjustable torque, screw gun to help you control the load applied to the fasteners. An adjustable depth control screw gun (dry wall screw gun) can be used successfully if the depth of penetration is set correctly. Dry wall guns do not control the torque or guarantee that the fasteners will be tight. Therefore, some failures and/or loose joints may result. Adjustable torque limiting screw guns manufactured by Black & Decker, Hitachi, and Mikita have proven to be effective for the installation of corner-lock fasteners.

1. TecCrete 1-1/8" Panel Corner Lock:

1/4" x 20 UNC x 1-3/4" long flat head screw
With a #2 Phillips drive head
Available in Black Oxide or Bright Zinc finish

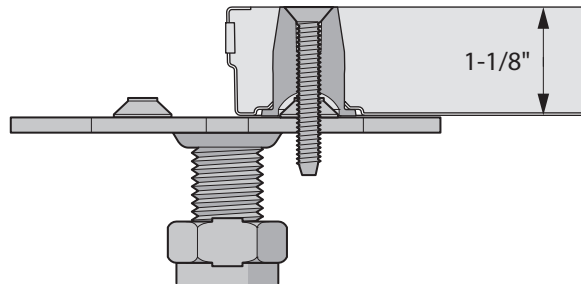
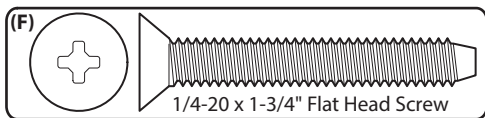

2. TecCrete 1-1/2" Panel Corner Lock:

1/4" x 20 UNC x 2" long flat head screw
With a #2 Phillips drive head
Available in Black Oxide or Bright Zinc finish

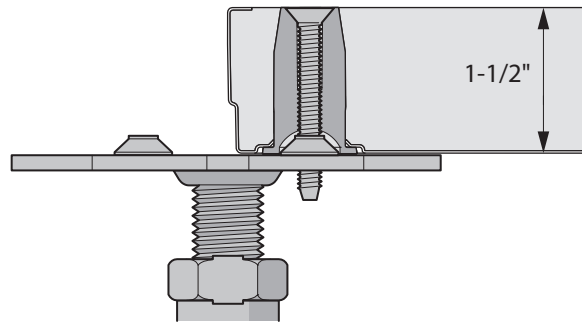
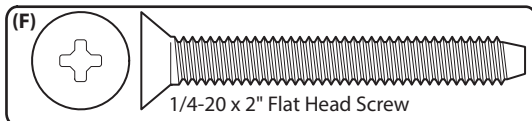

3. TecCrete 1-1/8" or 1-1/2" Panel Corner Lock on Stringers:

1/4" x 20 UNC x 3-1/2" long flat head screw
with a #2 Phillips drive head
Available in Black Oxide finish

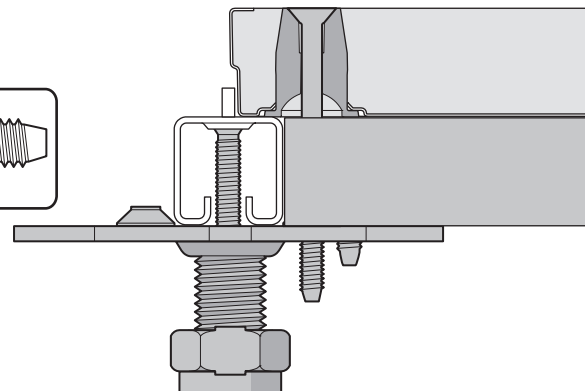
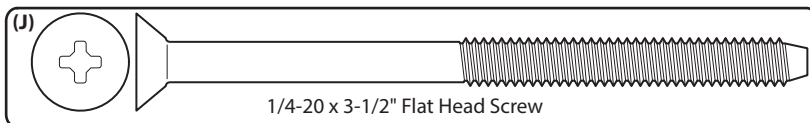

4. TecCrete 1-1/2" Panel with Laminate and Corner Lock on Stringer:

1/4" x 20 UNC x 3.5" long flat head screw
With a #2 Phillips drive head
Available in Black Oxide finish

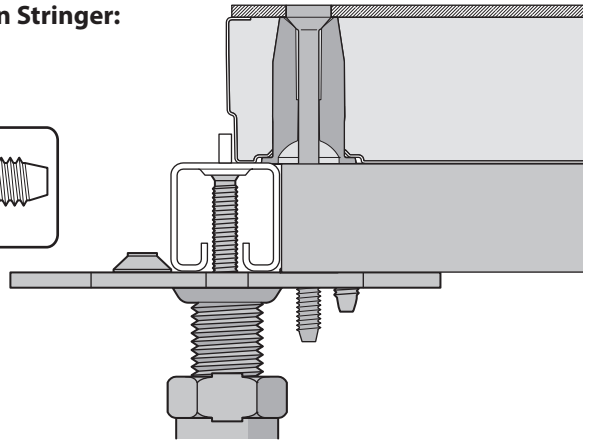
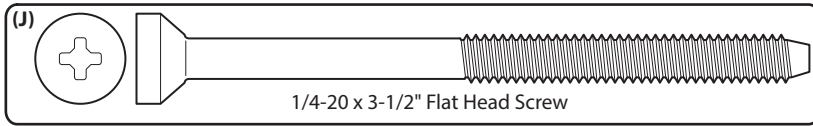

5. TecCrete 1-1/8" or 1-1/2" Panel with Laminate and Corner Lock on Stringer:

1/4" x 20 UNC x 1-3/4" long flat head screw
With a #2 Phillips drive head
Available in Black Oxide finish

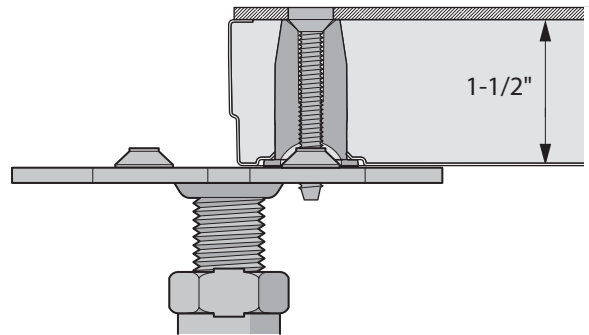
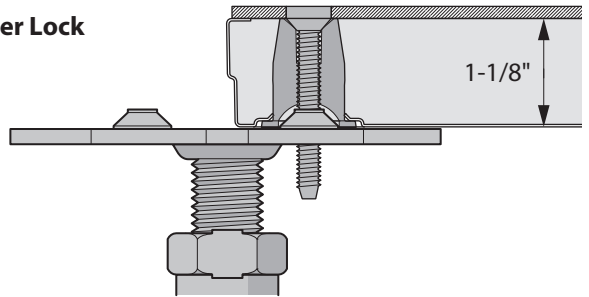
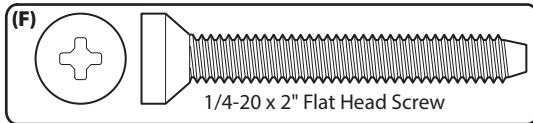

6. TecCrete 1-1/8" or 1-1/2" Panel with Laminate and Corner Lock on Stringer:

1/4" x 20 UNC x 2" long flat head screw
With a #2 Phillips drive head
Available in Black Oxide finish

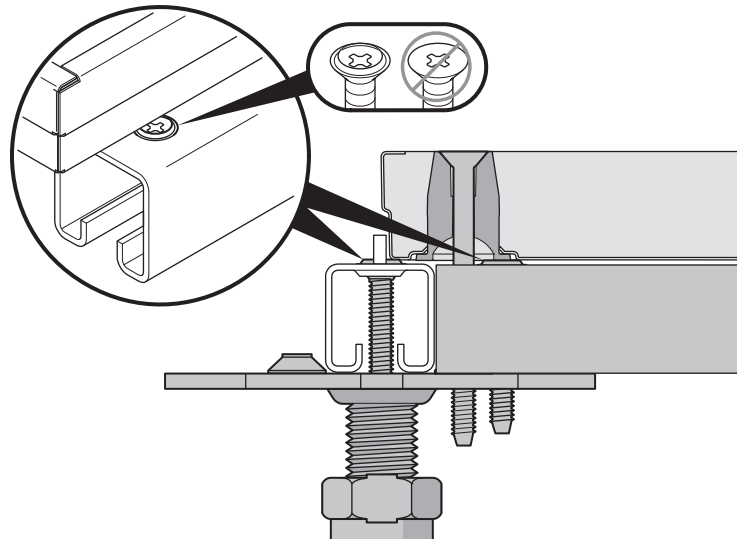
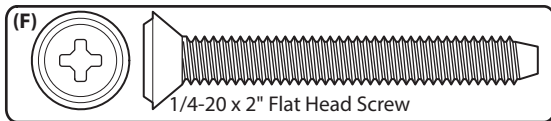

Panel to Pedestal Ground: The panel to pedestal ground path is typically requested for data centers but can be specified on other applications such as open office. The TecCrete system has a specified panel to pedestal resistance of 10 ohms or less when installed given the following parameters:

- TecCrete 1250 & 1500SL (corner lock, no stringers systems): Grounds automatically through the contact between the pedestal head and the panel.
- TecCrete 1500, 2000, & 2500 (stringer systems): Requires the use of the grounding screw to ensure contact points between the panel and the pedestal head to create the path to ground. A panel to pedestal resistance of less than 10 ohms using a stringer system cannot be guaranteed without the use of grounding screws.

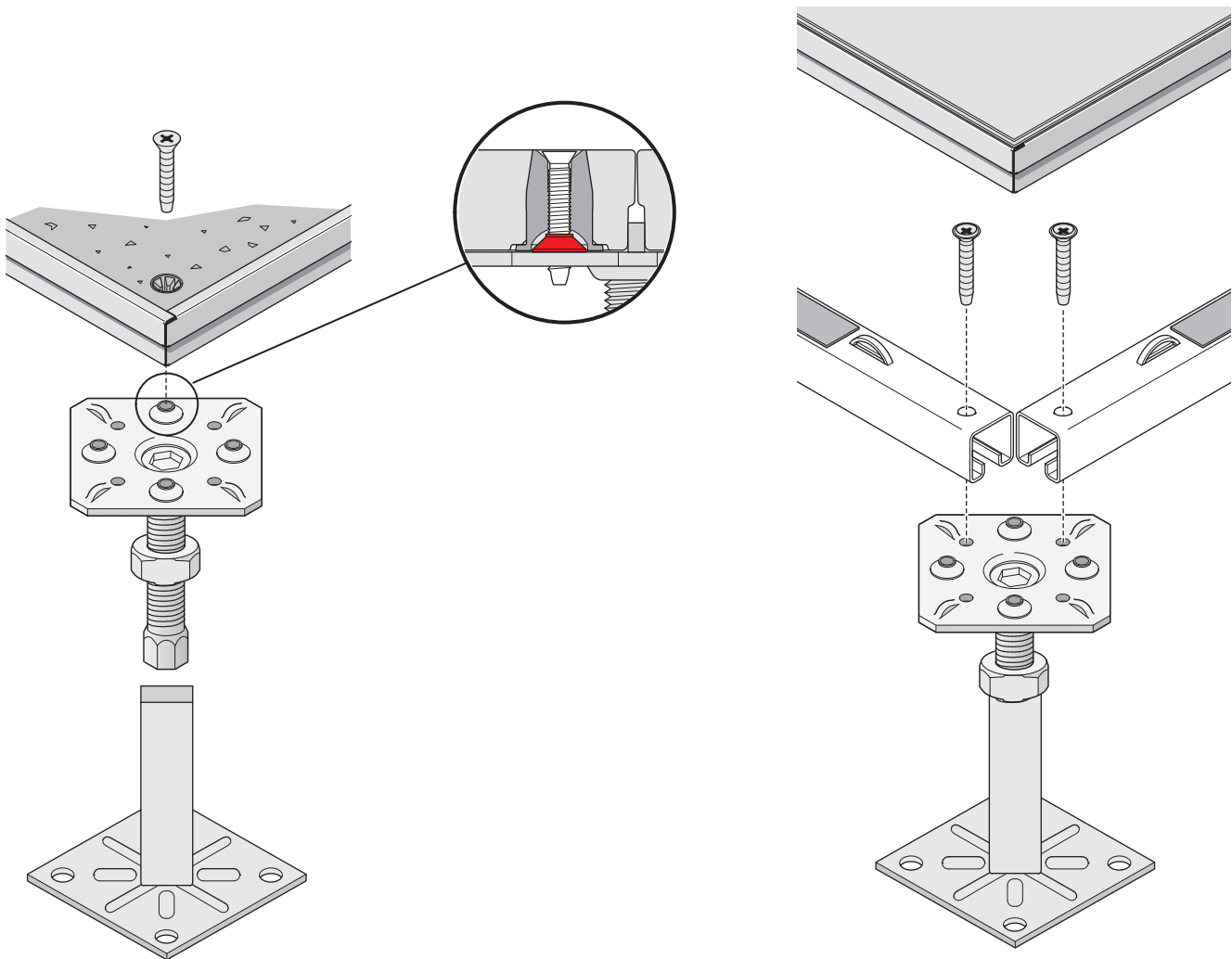

5.2 Mechanical Anchors for Pedestals

It may be desirable to have the pedestal bases attached using a mechanical anchor instead of adhesive alone in seismic zones, sloped floors, and for high finished floor heights. Powder actuated fasteners (short pins) are not recommended as a method to attach access floor pedestals in these critical situations due to the inconsistent nature of their holding power. Drilled in (Hilti Kwik-Bolt or equal) and screw in (Tapcon or equal) are recommended for these applications. Sizing and specific recommendations can be provided by Engineering as needed. When installing the access floor with mechanical anchors, it is also recommended to use a pedestal adhesive under the pedestal to compensate for any sub floor variation. The mechanical anchors should be installed after the adhesive has cured extensively. The adhesive prevents the base from conforming to an irregular concrete surface as the fasteners are tightened. Tightening the anchors before the adhesive is fully cured will force the pedestal to conform to the contour of the sub floor which may cause rocking panels and loss of module dimensions.

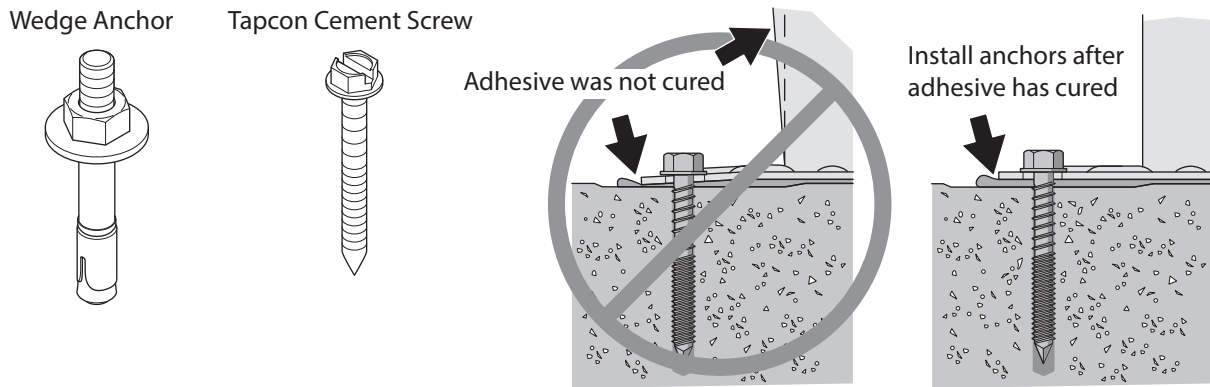

5.3 Attaching to Panels

Often attaching architectural elements, such as wall tracks, to the access floor panels is required. Shot pins with a maximum diameter of 0.188" may be used for these situations provided they are adequate for the job and are located 3" away from the edge of a panel. Expansion type anchors are not recommended for any application when attaching to the panels. Pressure from the expansion anchors may cause the concrete to crack and result in poor attachment. The best method is to through bolt the elements to the panels with a nut and washer, and again a minimum of 3" away from any edge is recommended.

If walls are secured at ceiling level or stabilized by attached perpendicular walls, then powder actuated pins can be used to fasten floor track to the surface of the TecCrete panel in combination with construction adhesive. Final wall calculations and attachment methods should be provided by other. A job site test should be completed for your specific application.

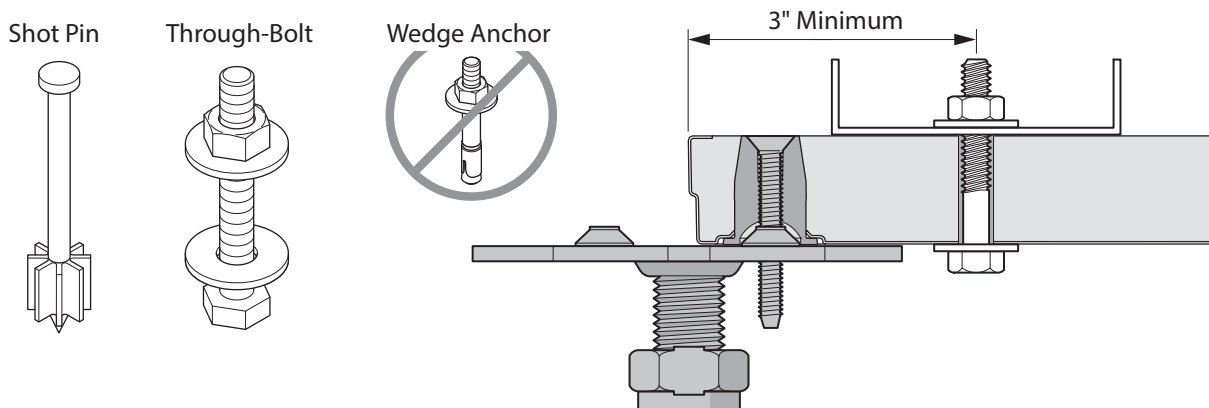

6 SUB FLOORS

A variety of sub floors are encountered under access floor installations. Listed below are the most typical types and some of the pitfalls encountered with each.

6.1 Concrete

Concrete is the most common building surface and generally does not present any installation difficulties. Dusting, surface flakes, and irregular finish present bonding and adjustment concerns. The pedestals must have a clean hard surface for effective bonding. Dust, water, grease, and dirt prevent good adhesion.

6.2 Sealed Concrete

Computer rooms and spaces using HVAC in the plenum will generally have a sealer applied to the concrete to harden, dust proof, and waterproof the concrete surface. There are hundreds of these products on the market. We have provided a short list of sealers that the standard pedestal adhesive has been tested with. If you are required to provide certified turnover performance on your project with another sealer, please consult with Engineering and do a physical test. This will take at least 60 days due to the drying or curing time of the adhesive, assembly of materials, and the certified test reporting time. Please plan appropriately.

Sealant	ADHESIVE			Supplier	Address	Website
	Envirotech	Polyped	Seal bond			
Super Trete 110 Cure & Seal	YES	YES	YES	Cresset Chemical Co.	Weston, OH 43569	www.cresset.com
OKON Seal and Finish (W-1)	YES	YES	YES	Rust-oleum Corp.	Vernon Hills, IL 60061	www.okoninc.com
Super Diamond Clear VOX	YES	YES	YES	Euclid Chemical Co.	Cleveland, OH 44110	www.euclidchemical.com
Aqua Kure	YES	YES	YES	Lambert Corp.	Orlando, FL 32805	www.lambertusa.com
EUCO Aqua-Kure VOX	YES	YES	NO	Euclid Chemical Co.	Cleveland, OH 44110	www.euclidchemical.com
1125 Silicate Cure/ Dayton Superior J-13	YES	NO	YES	Edoco by Datyon Superior	Kansas City, KS 66106	www.daytonsuperiorchemical.com

6.3 Wood

Wood sub floors are mostly encountered in renovation projects. Attachment of the pedestal bases can be a problem due to dirt, grease, wax, and varnishes. Generally, you should clean the spots where the bases are to be located for positive attachment by sanding or grinding. Screw attachment of the pedestals is also possible depending on the condition of the sub floor. Another problem encountered with wood sub floors is flexibility. The sub floor may move so much when loads are applied that the panels will not stay level, causing installation noise due to the movement of the sub floor.

6.4 Tile

Vinyl floor tile can be used beneath access floors but turnover performance cannot be predicted and the adhesive drying rate is very slow. The tile adhesive will be old and weak allowing the tile to pull off the sub floor. It is recommended to remove the tile in the pedestal locations. Caution should be used if the tile is reinforced with asbestos. This may be typical in many older buildings. Professional certified removal and disposal of the tile will be required. Drill-in anchors can also be used, but again, the asbestos dust from the tile must be properly handled.

Hard ceramic floor tile is seldom encountered but should be removed along with the existing mortar and grout. This tile would be too brittle to even accept mechanical anchors or other drilled inserts.

6.5 Metal Sheeting

Metal Sheeting is principally used in locations with high security. The sheeting blocks electromagnetic radiation from penetrating or escaping the area. Aluminum or copper foils do not provide adequate attachment for the access floor pedestals. Steel sheeting will have buckles and air pockets between the sheet and the sub floor. These conditions do not provide firm footing for the access floor installation and will allow movement in the installation. Solvent based pedestal adhesives do not dry as the solvents are trapped between the pedestal base and the sheeting.

6.6 Testing Pedestal Adhesives on Site

Testing the sealer and adhesive combination on the site may be the only way to evaluate the bond in a timely fashion. You should select a spot to adhere the pedestals that will not be disturbed for a period of 60 days, is clean and dry, (away from outside walls) and is as warm as possible to speed the cure of the adhesive. A barrier can be erected to protect the pedestals from accidental loads and from curious people. If the bond line is disturbed during the drying period, the pedestal cannot be reattached to provide the maximum turnover performance. Because you cannot predict how the adhesive will cure due to the sealer, temperature, humidity, and water content of the concrete, you will need to bond 8 to 10 pedestals down in order to have five pedestals for certified testing. The remaining pedestals will be used to evaluate the status of the bond prior to certified testing. Remove the entire excess adhesive at the perimeter of the base to expedite the curing process and firmly locate the base on the floor. After three weeks, break one of the pedestal bonds and examine the adhesive, concrete sealer, and the concrete looking for the following features:

- If the adhesive is cured, the adhesive will be hard and there will be a minimal amount of solvent smell in the adhesive. Let the adhesive set for another week and then do the test.
- If the adhesive is still pliable, especially in the center of the base, curing is not complete. After three weeks this indicates that the drying process will take a much longer period. The adhesive will always harden from the outside of the base to the center. The point where the adhesive becomes harder will give an indication of the drying time remaining. This can only be evaluated immediately after the bond is broken.
- Examine the concrete sealer removing the soft adhesive and the hardened adhesive from the concrete. Has the sealer bubbled, softened, or dissolved? These are signs that the sealer and adhesive are not compatible. You may want to use another type of adhesive such as water-curing polyurethane or a 2-part epoxy product. Follow the same procedure to verify compatibility with these products. These products harden by a chemical reaction creating full strength bonds in a much shorter time frame.
- If the sealer is only softened, has it re-hardened and bonded to the concrete at the perimeter of the base? If so, an extended cure time may be all that is required. Check another base in two or three weeks.
- The pedestals should be pulled over using a calibrated force gauge, preferably one with a dead hand to mark the maximum force applied to the pedestal. Use a constant, steady, pull or push against the pedestal base off of the sub floor recording the maximum load and the height the load was applied above the sub floor. The turnover moment will be the height the load was applied above the sub floor multiplied by the force used to break the bond. You should have at least five test specimens and average the results of the tests according to **CISCA Test Procedures**. Some specifications may require that the minimum pedestal turnover moment on all of the pedestals be over a given amount. Review the specifications for what is required for this test. (**See Section VI Pedestal Overturning Moment Test per CISCA Test Procedures Dated 2007**)

Following CISCA Section 6 "Pedestal Overturning Moment Test" procedure:

- Secure pedestal bases to the floor using desired attachment method. If using pedestal adhesive, wait a minimum of 3 weeks before testing to ensure that adhesive is fully cured.
- Once the pedestal base is fully cured, apply a lateral force to the top of the pedestal base. The force should be applied a minimum of $6 \times$ (width of base plate). For example, when using the Type 0 with a 4 inch base plate, the applied force must be at a minimum of 6×4 inches = 24 inches. For pedestal bases with a height less than the minimum applied load height, an extension bar must be fabricated that can be inserted 2 inches into the pedestal base.
- The overturn moment is calculated by multiplying the applied force by the distance from the applied force to the base plate. For example, a 100 lb force applied 24 inches from the base plate equals $100 \text{ lbs} \times 24 \text{ inches} = 2,400 \text{ in-lbs}$ moment.

6.7 Removal of Pedestal Adhesive from Sub floor

Removal of the pedestal adhesive from the sub floor can be hard to do. Once the adhesive has fully cured to the sub floor removal without damage to the concrete slab can be very labor intensified. We would suggest that the pedestal base plate be heated with a small blow torch or hot air gun to gently heat the surface of the base plate until the adhesive becomes plastic enough to allow the base to become unseated. At that point use mineral spirits or citrus based cleaning compounds to remove any left over adhesive on the sub floor.

6.8 Allowable Lifts to be Used on Access Floor

Please check with the flooring engineering team for the latest list of lifts recommended for use on Haworth Access Floor.

6.9 WARRANTY PROCEDURE

In the event that a defect is found in Haworth Architectural Interiors products that falls under the standard published warranty, the defects should be reported to Haworth Architectural Interiors in a timely manner. Haworth Architectural Interiors desire is to correct problems experienced in the field and to take any corrective action that may be dictated within our own manufacturing processes to prevent future occurrences.

2. When reporting defects to Haworth Architectural Interiors, the information needed to allow us to process the report is as follows:
 - Include the Haworth Architectural Interiors job number, which can be taken from the order acknowledgment and/or invoice and the date when the product was installed.
 - A description of the defect.
 - The scope of the problem such as quantity (or estimated quantity) of items exhibiting the defect. Depending on the scope of the problem, a field visit from a Haworth representative may be required.
 - Impact of the defect upon ongoing installation work and progress on the job.
3. Before incurring any expense in relation to taking field corrective action on the job, Haworth requires the submission of a written estimate of such costs for prior approval by Haworth Architectural Interiors.
4. Haworth will not accept back charges for cleaning, corrective action, or extra work unless notified and agreed upon in writing prior to the performance of any such work. See page 36 for test setup diagram.

Pedestal Overturning Moment Test

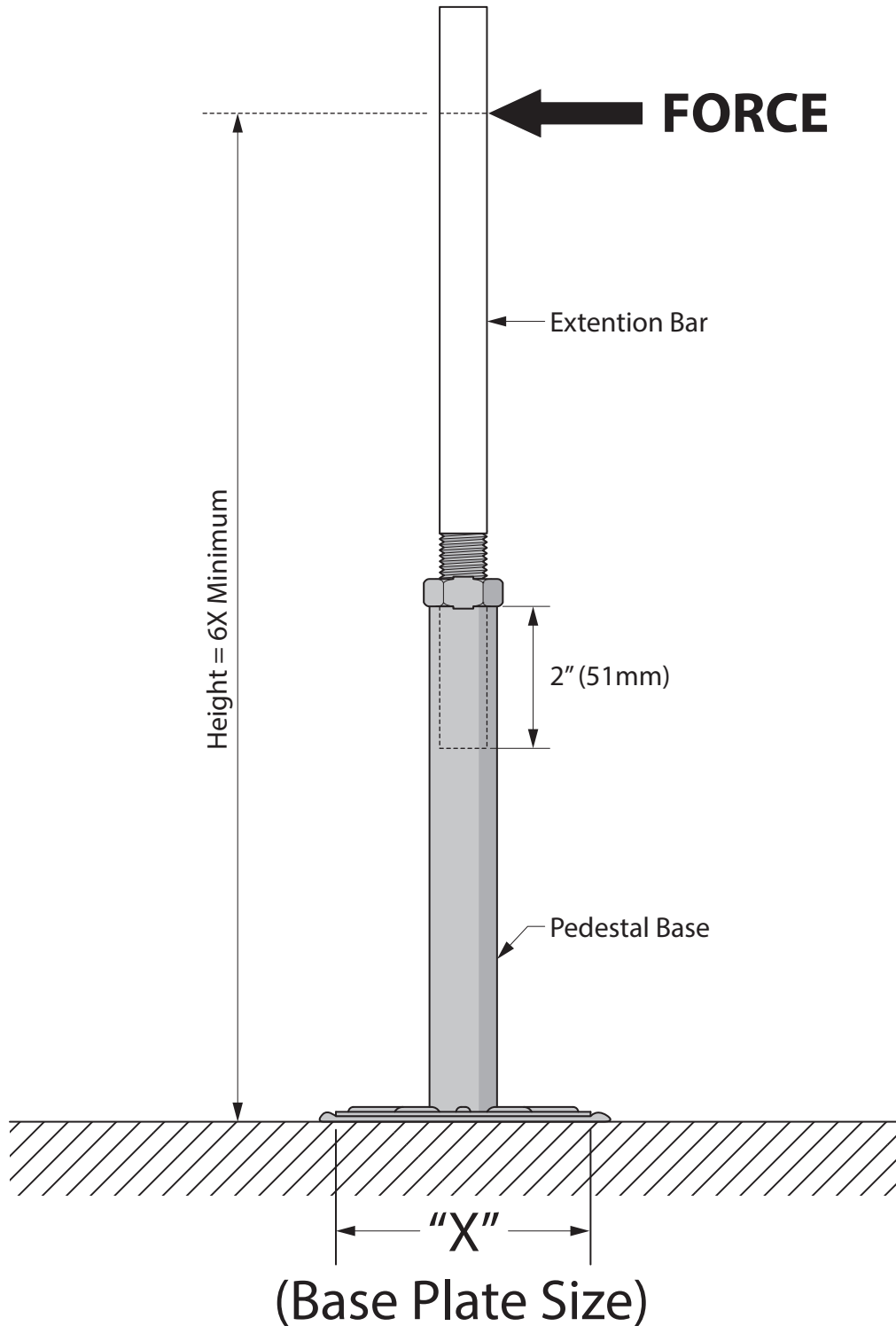

(Base Plate Size)

TEST SETUP FOR PEDESTAL OVERTURNING MOMENT

7 CUTTING INSTRUCTIONS

7.1 Cut-Outs

It is recommended that interior cutouts be made at the factory. Cutouts should not be located closer than 3" from any panel edge. Most common is for cutouts to be centered in a quadrant of the panel to allow the cutout location to change when the direction of the panel is changed.

Panels with cutouts should never be installed in high foot traffic or heavy rolling load areas.

Cutouts for electrical boxes should be located under the desk and cutouts for air diffusers should be located along the perimeter of the building or in the office cubical but away from the casters of chairs.

If cutouts are required to be done in the field, after field, make sure that you have the proper power tools required to make these cutouts.

Depending on the size of the cutout and the location of the installed panel, extra pedestals maybe needed along side the cutout to support the edge of the panel. If more than 1/4 of the panel surface is cut away, after cut away, additional pedestals supports should be used. Talk to flooring engineering for a recommendation on additional pedestal support.

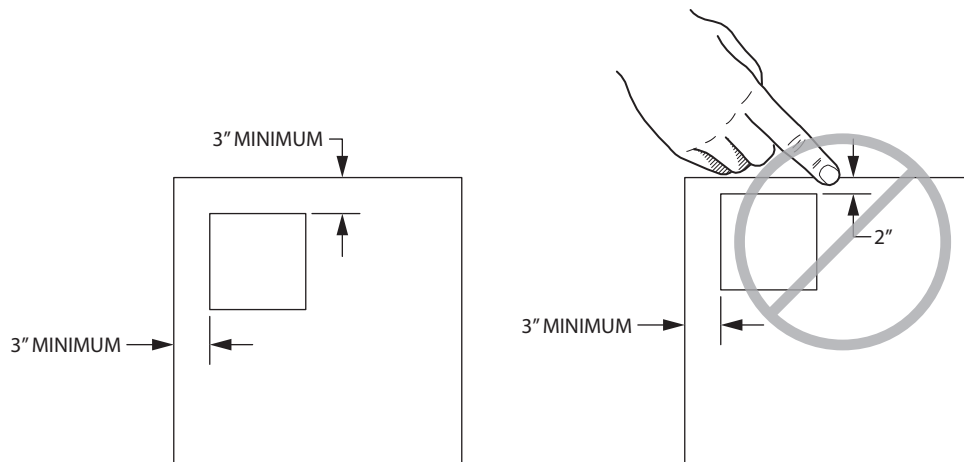

1. Straight Cuts

Cuts which are to be made in a straight line, i.e., without a radius, can be accomplished using either a circular saw, wet circular table saw, or a band saw. All cut lines at 90 degrees should end in a drilled hole to minimize cracking of the panel at the corner. The following is a list of suggested equipment and the procedure for using each type of tool.

All steel edges should be deburred to eliminate sharp edges.

a. Circular Saw

A worm gear driven saw with a diamond or carbide tipped blade is an economical method for cutting panels. All cuts with circular blades on concrete panels should end in a drilled hole to minimize cracks at the corner of the cut. An overrun at an angle can cause the concrete panel to crack at the corner. You can prevent the overrun by finishing the cut off with a bayonet saw in the corners. The circular saw will produce some dust. Locate the saw where the dust can be contained and cleaned up.

- Suggested Circular Saw: Model 77 Skilsaw, 7-1/4" diameter, 13 amp, and worm drive. Available nationwide from distributors of the Bush Powertool Company, 4300 West Peterson Ave., Chicago, IL 66046, telephone 773/286-7330.
- Suggested Diamond Saw Blade: Diamond dry cutting segmented blade, 7" diameter x 0.080" with 5/8" arbor. Available nationwide from distributors of Diamond Products, Inc., 333 Prospect St., Elyria, OH 44035, telephone 440/323-4616.

b. Wet Circular Table or Radial Arm Saw

When job site conditions allow wet cutting, this method can save you time and increase the life of the blade. Wet cutting with a table or radial arm saw provides straighter, cleaner, and dust-free cut panels. Corners should also end in a drilled hole and the cut finished with a bayonet saw to prevent the corner overrun of the circular blade. After completion of the cut, the panel should be cleaned and allowed to dry before stacking or installing the cut panel in the floor. These saws are used in the concrete block, brick, and pavers installation industry.

- Suggested Table Saw: Target Stone Matic (Manufactured by Target Ind.)
- Suggested Saw Blade: 10-2 inch Diamond Tooth Blade.

c. Band Saw

A band saw can also be used for straight cuts. Again, the corners of the cut should end in a drilled hole to minimize cracking. A minimal amount of concrete dust is generated by this method. Dust control by using a vacuum dust collector is optional.

- Suggested Band Saw: Mobile Applications Model MA-615, Zepco Incorporated, 5415 Perry Dr., Waterford, MI 48329, telephone 248/674-8450. This saw has a 24" throat, weighs only 120 lbs and is portable.
- Suggested Band Saw Blade: Simonds 3/4" or 1/2", 3 teeth per inch, Simonds Type 1 Carbide Tipped Band Saw Blade, telephone 1-800/328-3808, or Remington "Grit Edge" Tungsten Carbide 1/2" gulletted, coarse blade. For a radius less than 1-3/4" use 1/4 wide blade. The blade should be run at 260 feet per minute. Available from distributors of the Remington Arms Company Abrasive Products Division, Bridgeport, CT 06602.
- Straight cuts should be at least 3 inches wide at the edge of the panel..

2. Radius Cuts

Cuts on a radius can be made with a band saw utilizing the same band saw equipment and procedures as that listed under straight cuts or with a power drill motor and a masonry drill or by using a core drilling machine with a concrete core bit. The masonry and core bits are run dry. A commercial grade vacuum with a wide mouth attachment placed in close proximity to the concrete core drill or core bits should be used for dust control. All edges should be deburred to eliminate sharp edges.

- Suggested Masonry Drill: 5/8" carbide tipped with 1/2" or 3/8" shank. Available nationwide for distributors of the Cleveland Twist Drill Co., Cleveland, OH.
- Suggested Core Bits: Core bits range in size from 1/2" to 10" diameter. Available from Diamond Products Inc., 333 Prospect St., Elyria, OH 44035.
- Suggested Core Drilling Machine: Core Bore Model M-3. Available from Diamond Products, Inc., 333 Prospect St., Elyria, OH 44035.

Radius cuts should be made at least 3 inches from the edge of the panel.

3. Interior Cuts

An interior cut is defined as a four sided cut completely surrounded by the panel. It is recommended interior cuts be made at the factory. If done in the field drill each corner of the area cutout using a carbide tipped masonry drill. Then using either a circular saw with a dry diamond segmented blade, a wet saw, or an orbital bayonet saw to cut from hole to hole. Drilling the corner holes is required to minimize the cracking in the panel at the sharp corner created by two straight cuts.

- Suggested Blade: Simonds 1/2", 3 teeth per inch Simonds Type 1 Carbide Tipped Band Saw Blade, telephone 1-800/328-3808, or a Remington SS4-3C 1/2" wide x 4" medium core grit blade.
- Suggested Saw: Milwaukee Sawzall or a Black & Decker Pro Orbital.

Interior cuts should be made at least 3 inches from the edge of the panel. Interior cutouts should not take up more than 1/4 of the area of the panel.

4. Carpet Tile Adhesive

Carpet tile adhesive can be applied to the surface of TecCrete panels without problems provided the application of the adhesive is controlled and that the adhesive is allowed to dry before applying the carpet tile over the adhesive. Excessive amounts of adhesive applied at the edges of the panels will cause the panels to be adhered to one another making it necessary to cut the adhesive between the panels to remove the panels. A thick adhesive line also takes longer to dry and can result in oxidation of the panel due to entrapped water in the adhesive. Most carpet tile adhesives use water as the emulsifier and are slightly acidic, if the adhesive does not thoroughly dry before the carpet tile is applied, the water and acidic nature of the adhesive may cause the top surface and the perimeter of the TecCrete panels to slightly discolor. This can only be avoided by making sure the water has completely evaporated before the carpet is applied. Excessive adhesive build up between panels may cause them to squeak when walked on due to the hardened adhesive rubbing between adjacent panels as loads are applied to the panels.

These problems can be controlled by spraying a film of adhesive across the panel surface or using the more common method of rolling if the adhesive is leveled on the roller before attempting to spread the adhesive on the panel surface paying particular attention to the panel perimeters.

Other options include:

- **Adhesive Dots** - some carpet suppliers offer adhesive that is placed in strategic locations to hold the carpet tile to the access floor rather than across the entire surface. This makes access to the underfloor a little easier in the future.
- **CarpetLok** - is a carpet anchor offered by Interface carpeting which allows the carpet squares to match up to the access floor panels and hold the carpet in place without adhesive for easier access to the sub floor in the future.

NOTE: These carpet attachment methods may not provide the same air seal as is achieved with adhesive applied across the entire panel surface and edge.

5. Sealing TecCrete

When TecCrete is being used bare (without carpeting or any other covering) Haworth recommends that the panel be sealed.

There are many concrete sealers on the market that will work with our TecCrete panels. Haworth does not specifically recommend any one brand of sealer over another. Here is a list of sealers Haworth Flooring Contractors have used with success.

Sealer Name	Manufacturer	Finish	Comments
EUCO Super Diamond Clear	The Euclid Chemical Company 19218 Redwood Road Cleveland, OH 44110 800.321.7628 www.euclidchemical.com	High Gloss	High VOCs and strong odor when applied, but it gives the floor a nice sheen when dry
EUCO Diamond Clear VOX	The Euclid Chemical Company 19218 Redwood Road Cleveland, OH 44110 800.321.7628 www.euclidchemical.com	Semi-Gloss	High VOCs and low odor when applied
Super Aqua Cure VOX	The Euclid Chemical Company 19218 Redwood Road Cleveland, OH 44110 800.321.7628 www.euclidchemical.com	Mat Finish	Low VOCs and low odor
ECO Procote Soy Crete Concrete Stain	The Safety Products 1522 E. Victory St., Ste 2 Phoenix, AZ 85040-1307 877.366.7547 www.ecosafetyproducts.com	Colored Stain	Very low VOCs and very low odor, lots of colors

Haworth is unaware of any chemical incompatibility between our access floor and these sealers, but due to the variability of site conditions and customer preferences the product should be tested on-site before applying the sealer to the entire floor.

Please note: To get the best results, it is important to follow the manufacturer's directions for whichever sealer you are using.

9. LATERAL BRACE KITS

Lateral brace kits consist of two metal straps and a turnbuckle. They are used in any location where the floor must be restrained against lateral movement such as fascia conditions, steps, ramps, or equipment locations. Attach the brace to the subfloor with a mechanical anchor and then to the access floor panel as shown in Figure 13. Tighten the turnbuckle by hand to secure the panel in place. Attach any fascia after the brace is installed. (See figure 13)

Figure 13

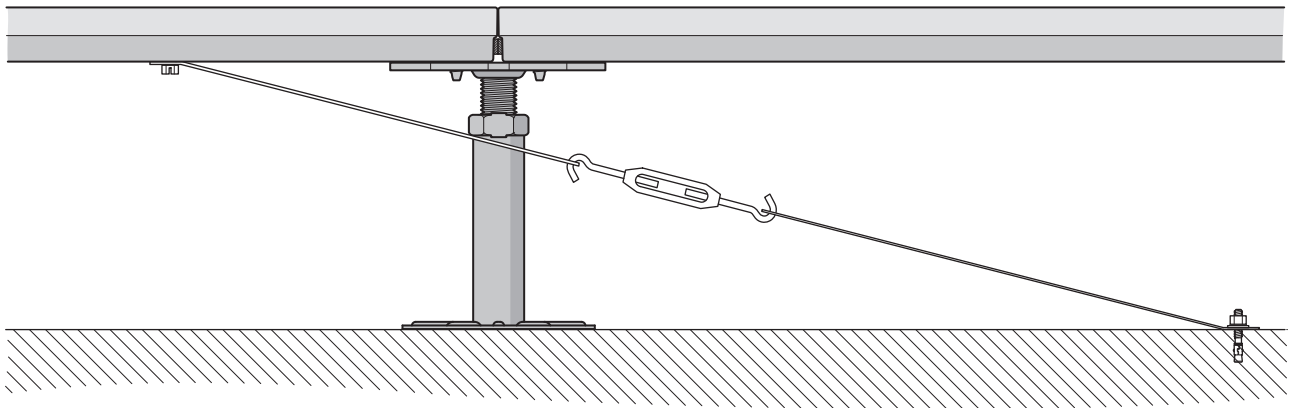

10. GROUNDING OF THE ACCESS FLOOR SYSTEM

Grounding of the access floor system is provided for three basic reasons: a) a drain path for static electricity; b) protection of people working in the access floor plenum against electrical shock; and c) to provide a reference grid for some high speed computer communication. Each of these reasons has different design requirements and the on-site Electrical Engineer should be consulted regarding these needs for any facility. Typically, the various grounding systems are installed by electrical contractors. A brief discussion of each of these elements is provided below.

10.1 Static Control

The principle element in static control is the selection of the floor covering on the access floor panels. Various levels of static control are required for different end uses.

Most access floor specifications use the NFPA 99 or ASTM F-150 test procedure. This resistance range provides personal shock protection and a drain path for static charges to the understructure. This resistance range also reduces the sensible static discharges felt by personnel working in the area. High pressure laminates and ESD carpet finishes provide this range of surface to understructure resistance when measured by NFPA 99 or ASTM F-150 test procedures. Thus, these finishes are suitable for most computer room and general office applications. ASTM F-150 defines a static dissipative floor as one that has surface to surface and surface to ground/understructure resistance ranging from 1 mega-ohms to 1000 mega-ohms.

The NFPA 99/ASTM F-150 procedure is also specified in more critical areas such as clean rooms and electronic assembly areas. ASTM F-150 defines a conductive floor as one that has surface to surface and surface to ground/understructure resistance ranging from 0.025 mega-ohms to 1 mega-ohm. These applications require faster drainage and lower accumulation of static charges to prevent damage to exposed circuits. Access floors can conform to this specification by using conductive floor finishes applied with conductive adhesives.

Carpet tile specifications will typically use the AATCC-134 method to produce a maximum static accumulation rating for the carpet construction under the methods used in the test. A rating of 3 KV (kilovolts) is generally considered suitable for the general office by the carpet industry. This specification method may not mean a particular carpet construction is suitable for general office or computer room applications. Some carpets conforming to the 2.0 KV rating may be constructed of polyolefin fibers which are not acceptable for high wear application, nor do they provide a consistent path for draining static electricity.

In some applications, it is appropriate to attach the access floor components to a building ground which provides a complete path for the static drainage. Attach a #6 copper grounding wire to a pedestal at a minimum of once every 3000 sq ft and connect it to the building ground for this function. Consult the onsite electrical engineer for specific site requirements.

10.2 Electrical Safety

The purpose of electrical safety grounding is to establish a path for accidental power connections to be forced to the building ground. This should cause a fuse to blow or a circuit breaker to disconnect. If this does not happen, the electrical circuit could remain "live" until a ground path is made. If the ground path is a person working on the floor or working in the floor plenum, they can establish a ground path by touching a conduit, water pipe, or building element and then receive a shock which could be life threatening. Interconnecting the access floor components with low resistance connections and attaching the access floor to the building ground prevent this situation. Specifications will call for the resistance from the panel to understructure to be less than 10 ohms. To comply with this specification Haworth recommends using our grounding stringer screw to create a low resistance path from the panel to the understructure. Additionally, the access floor support system may be connected to the building ground by using a minimum #6 copper grounding wire in the following frequencies:

- Corner-Lock and Bolted Grid Systems: At a minimum of one connection point for every 3000 sq ft.
- Stringerless Non-Corner Lock Systems: At a minimum of one connection point for every 400 sq ft.

The exact size of the grounding conductor should be selected by the maximum voltage and amperage that is present in the floor plenum. Please refer to the National Electrical Code and your local electrical code requirements.

Project specifications may have other requirements for grounding. Be sure you are complying with them.

10.3 Reference Grids

Reference grids are used to interconnect high speed computer equipment to ensure that the data transfers are not affected by ground shift potentials between the two computers. They require complex connections and are typically constructed from 4" wide copper bands or heavy copper wires interconnected with welded or bolted connections. This system is placed beneath the access floor panels and is connected to the computer frames. The grid network is connected to a separate grounding bar isolated from the building ground. Alternatively, the access floor stringers may be used as a reference grid in some applications. Specifications typically call for the stringer to pedestal bonding resistance to be from 100 micro-ohms to 100 milli-ohms.

If stringers are used as reference grids, you must:

- Clean, degrease, and brush the stringers surface and pedestal head where they meet. This removes any foreign matter and surface corrosion which could be on the parts.
- Apply conductive grease such as Thomas and Betts Copper Shield to the mating surfaces. The grease seals out moisture and air retarding oxidation at the joint between the pedestal head and stringer.
- Test your work in the field. Contact a reputable electrical testing laboratory for the specialized testing equipment needed to measure resistance this low.
- Clean and reapply the conductive grease if the joint is broken after installation.
- Inform the General Contractor of the completion of the installation and testing, and get their approval. Also advise them that subsequent disturbance of the stringer connections will require the cleaning and conductive grease to be reapplied and the connections tightened to a maximum 40 in-lbs of torque.

11 FASCIA APPLICATION & STEP DETAILS

Fascia installation

Attach the bottom angle to the sub floor using pedestal adhesive. If installing fascia while the adhesive under the pedestal is wet; slide the leg of the angle under the pedestal base plate and secure the pedestal to the angle with adhesive. If you are installing the fascia after the adhesive has set cut the bottom angle to fit between the pedestal base plates.

Cutting the fascia plate to the proper height by holding the fascia against the bottom angle and the edge of the access floor. Mark a line by using the top edge of the access floor as a guide. Cut the plate 1/8" shorter than the line so the cut fascia will come just short of the top edge of the panel. Cut sections of top angle bracket and miter all corners. Drill and countersink holes in the top of the trim angle at 18" intervals. Attach the top angle to the panel side floor surface making sure to firmly secure the fascia plate against the panels. Note: The top angle bracket should be installed over the top of the floor covering.

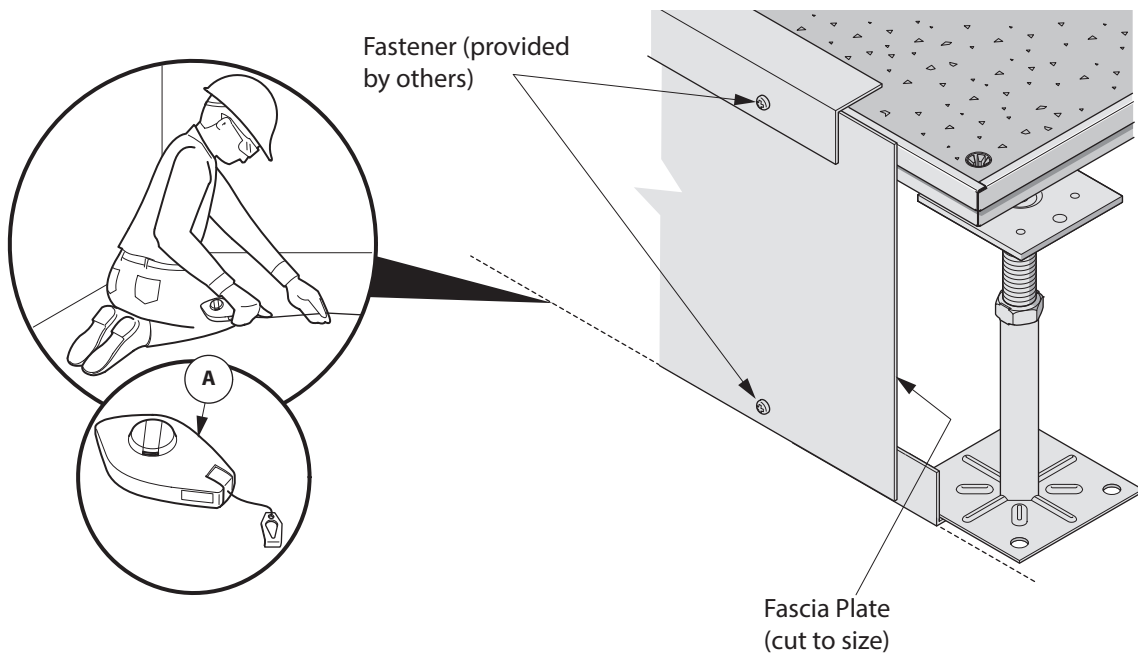

11.1 Step Installation

When building steps with access floor materials limit the overall height of the step assembly to three risers. Keep the width of the steps to 2 foot increments if possible to allow uncut panels to be used. Verify step tread and riser dimensions with local code officials. As a general guideline use 12" deep and a riser height of 6". Cover steps with a non-slip floor covering.

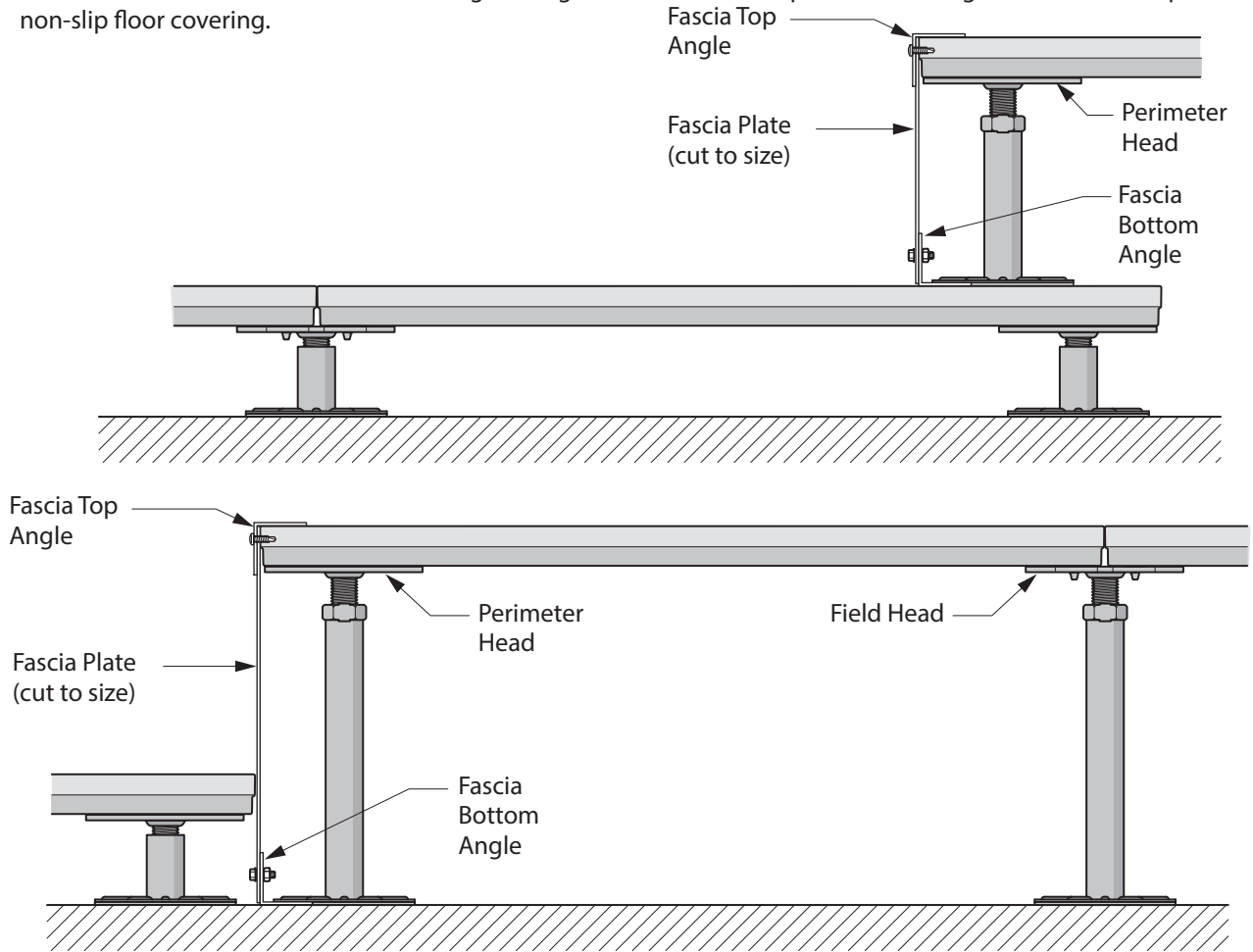

11.2 Transition from 1-1/8" panels to 1-1/2" panels

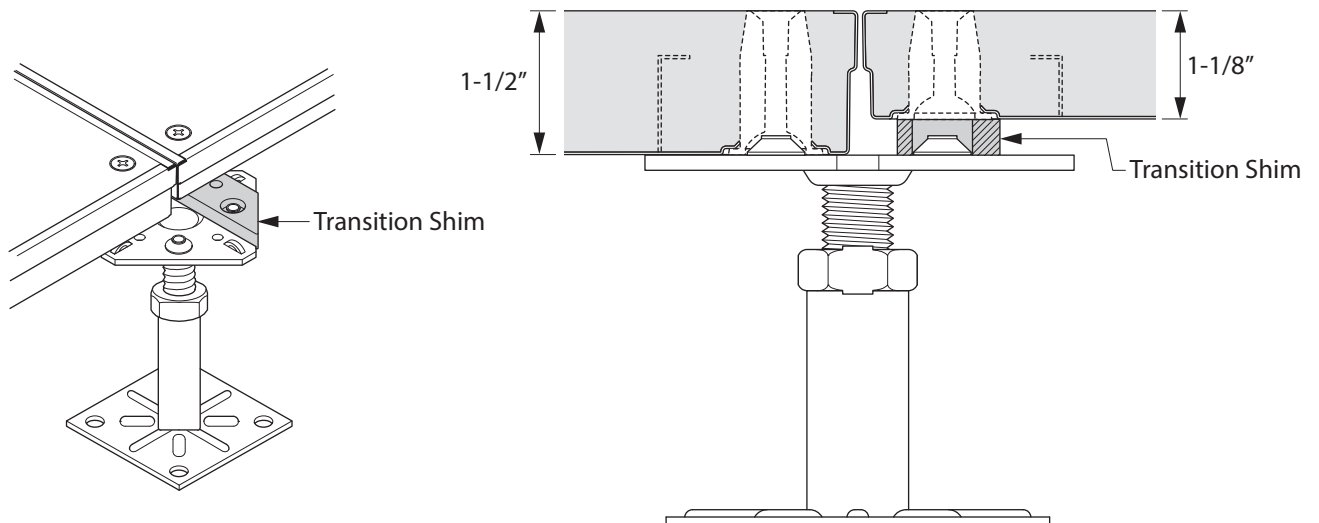

12 Triad Panel used adjacent to TecCrete Panel

Corner risers are used to match up to the TecCrete panel heights. These are field installed. There are different height corner risers depending on the height of the adjacent panel and surface finish.

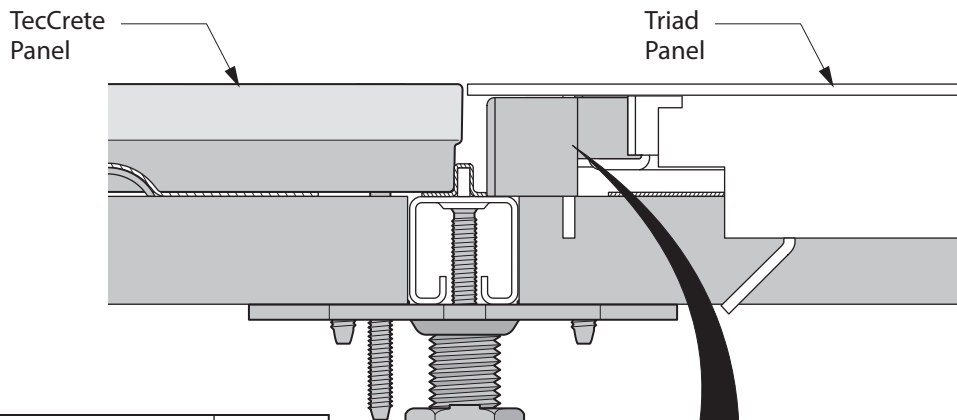
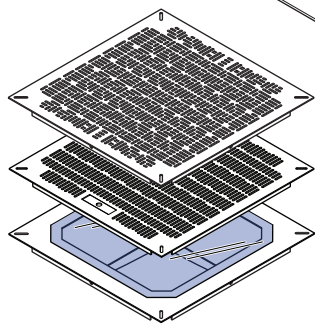
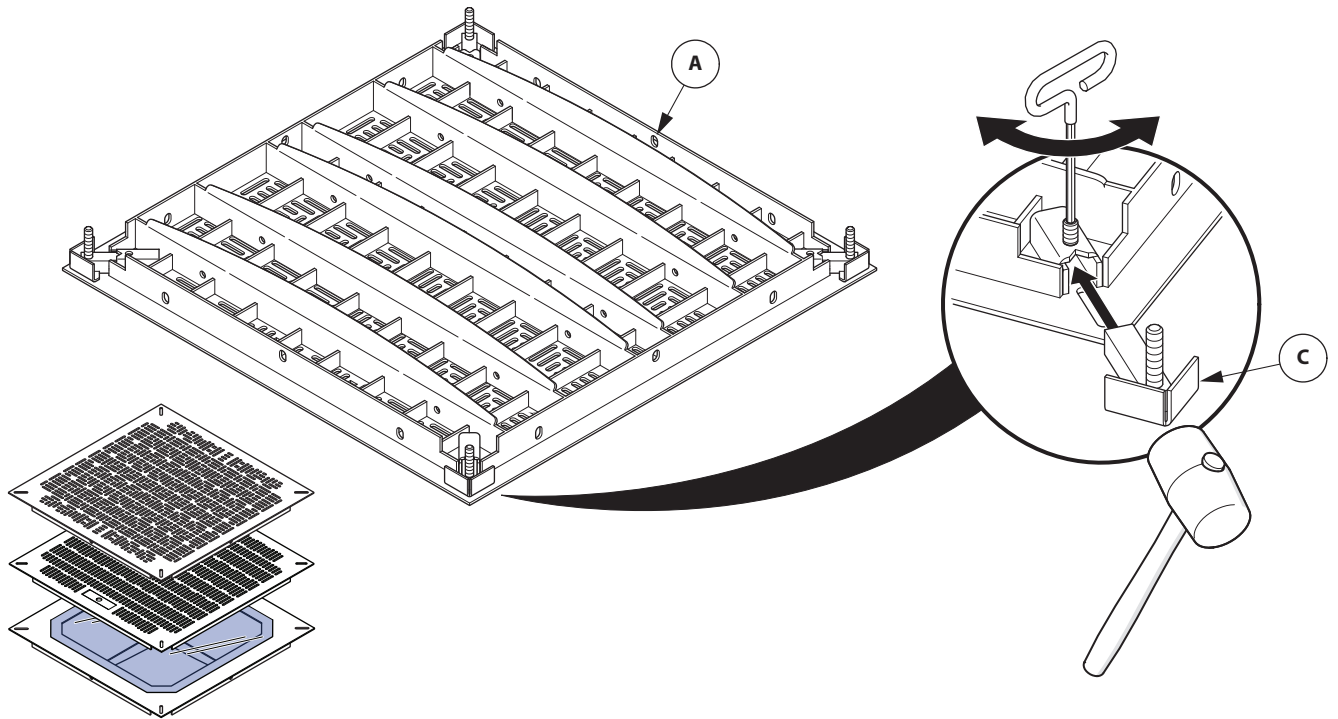

Height of Adjacent Panels	Corner Adapter X
1-1/8" Bare TecCrete	1-1/8"
1-1/8" TecCrete with 1/16" Laminate	1-3/16"
1-1/8" TecCrete with 1/8" Laminate or Vinyl	1-1/4"
1-1/2" Bare TecCrete	1-1/2"
1-1/2" TecCrete with 1/16" Laminate	1-9/16"
1-1/2" TecCrete with 1/8" Laminate or Vinyl	1-5/8"

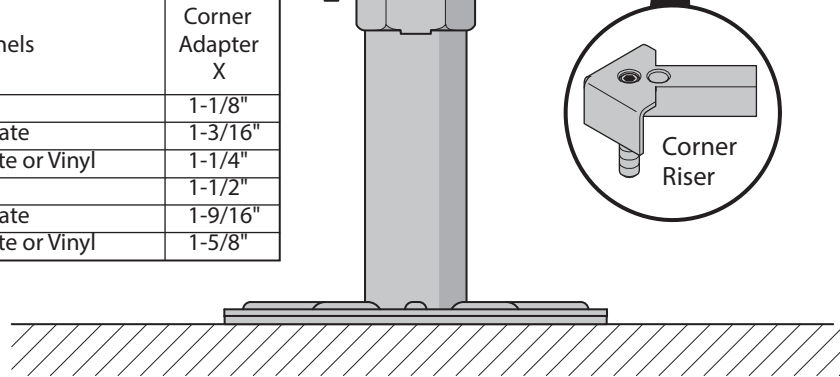
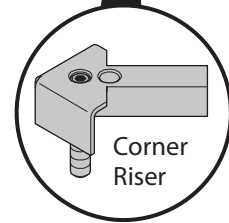

12.1 Triad Panel used with other panels

Installing with TecBase 1/16" laminate require the t-arm corner riser.
Installing with the Tate posilock pedestal requires a t-arm (shown below).
Installing with the Tate bolted stringer pedestals does not require a t-arm.

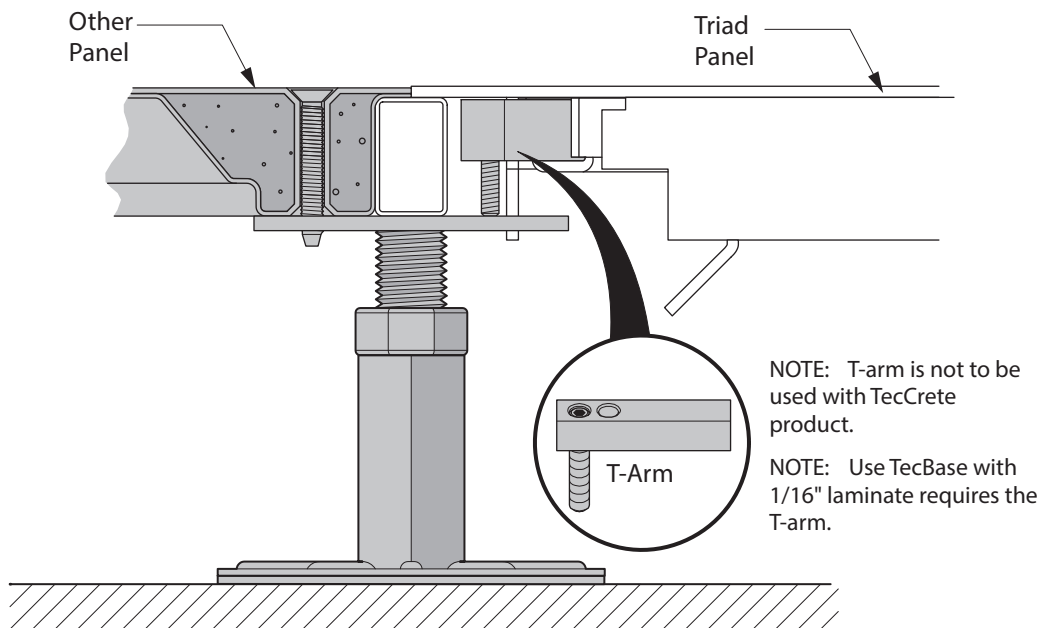
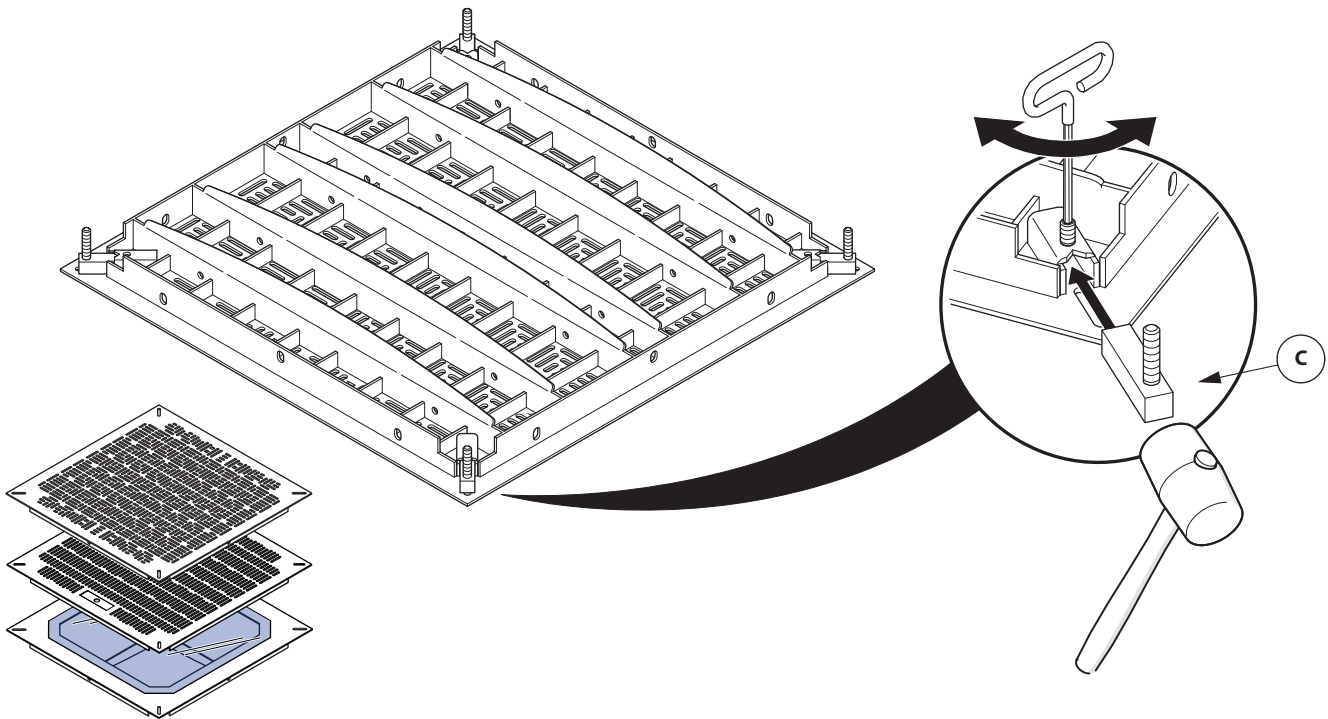

12.2 Optional - Air Baffle Installation

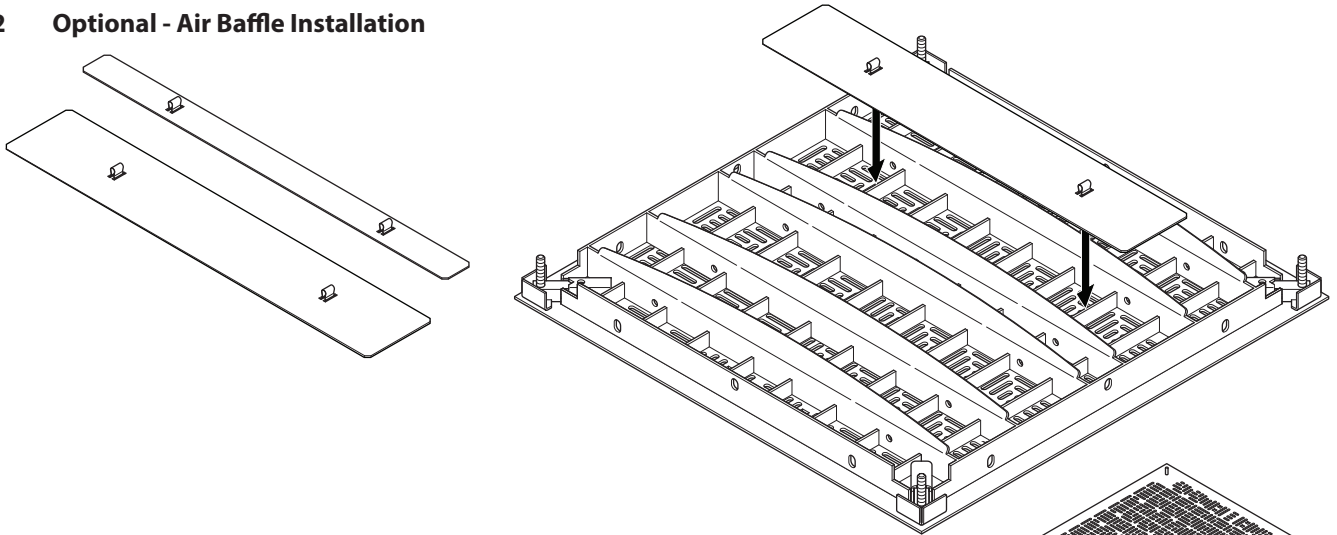

12.3 Optional - Slide Damper Installation

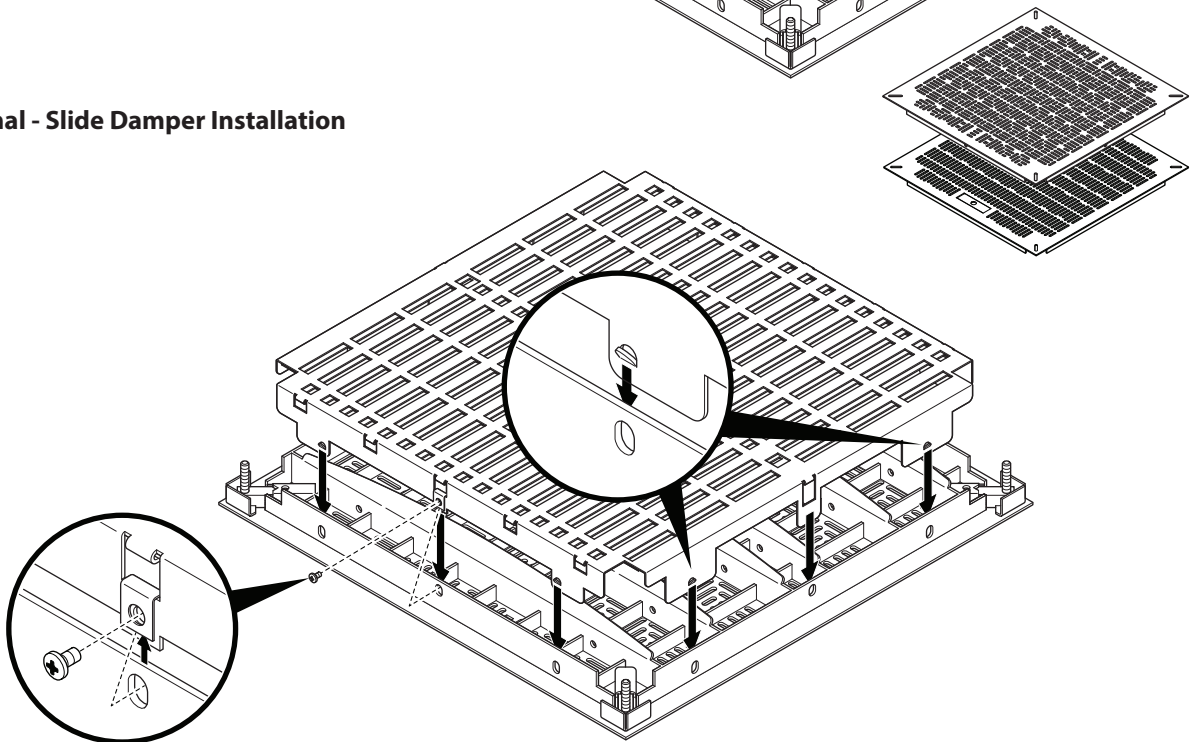

12.4 Optional - Slide Damper Adjustment

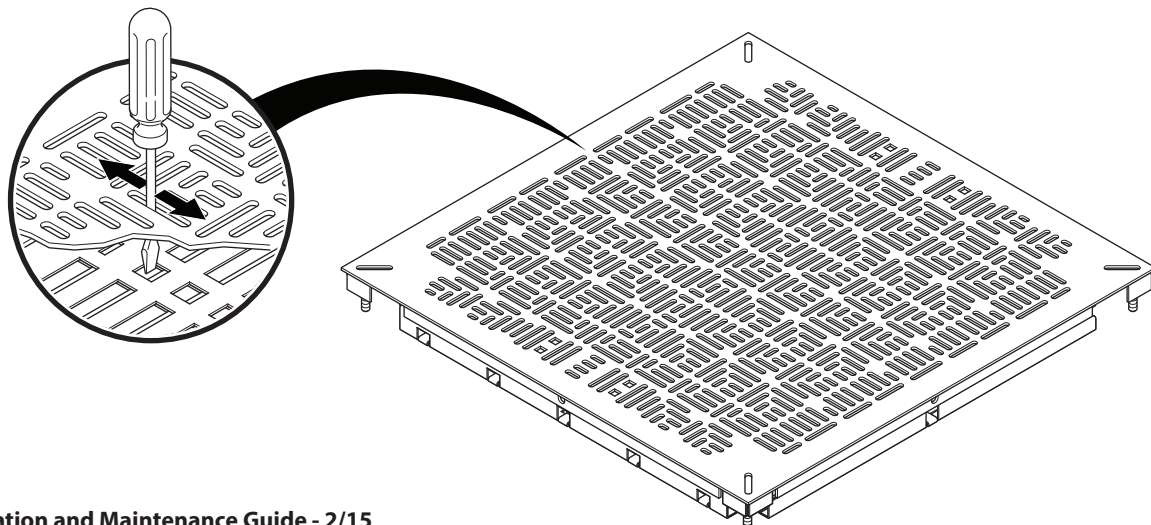

12.5 Optional - Blade Damper Installation and Adjustment

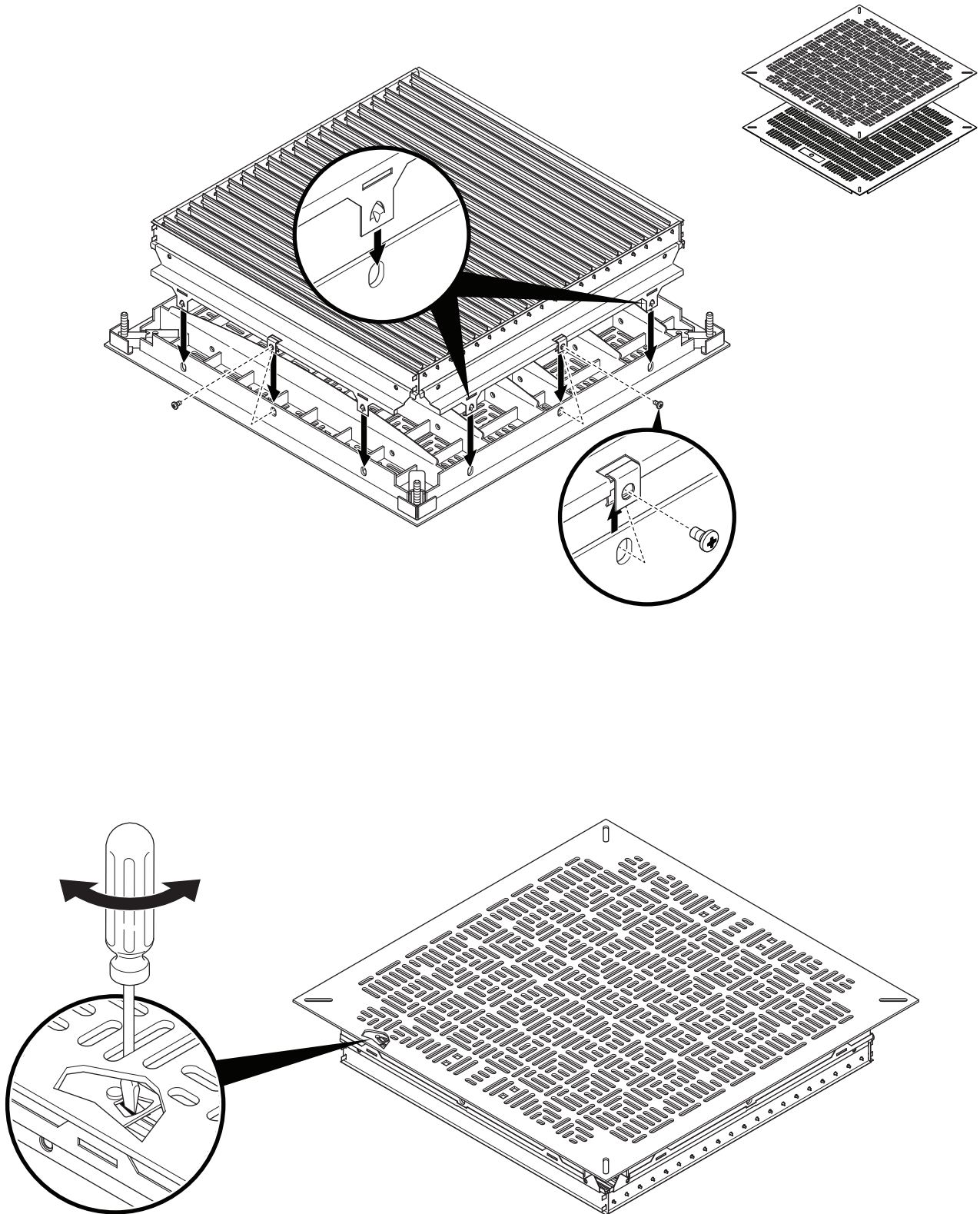

12.6 Air Stratification Positioning

To improve Upper Server cooling, position scoop of Hi-Plume fin towards source of air supply. To reduce Upper Server cooling turn scoop of Hi-Plume fin away from source of air supply.

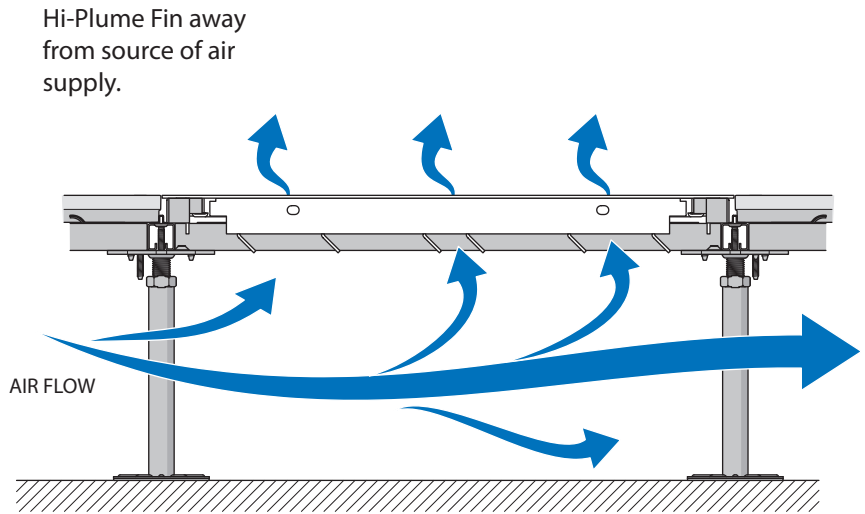
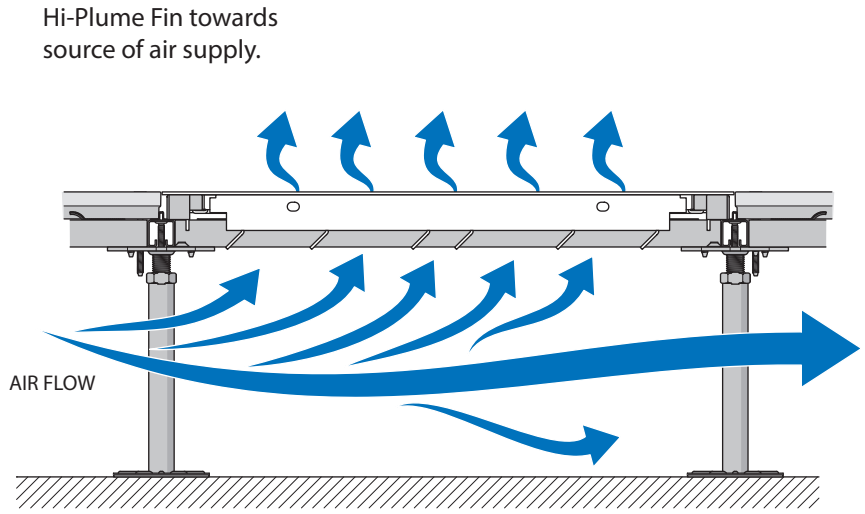

13 LEAKAGE

It is important to effectively prevent unintentional air leakage in a TecCrete access floor installation. Your general contractor should seal the building at the slab-line before the access flooring is installed. Irregular wall surfaces may require gaskets, caulking or tape to properly seal access floor to wall connections. It is also important that all utility access points be carefully sealed using plenum rated sealing material at all seams, around pipes and columns.

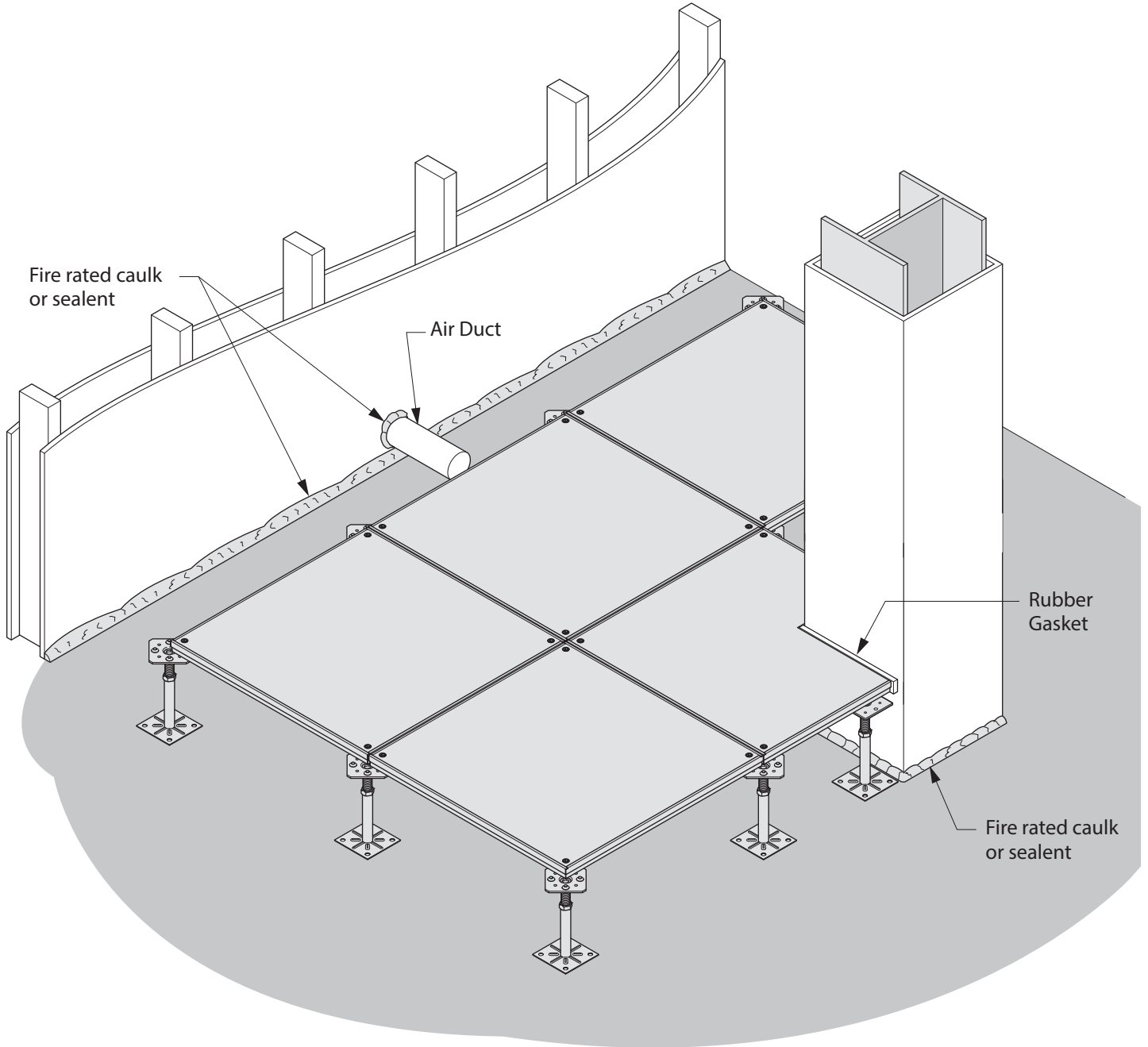

14 BRIDGING

Haworth can make a recommendation on bridging but all bridging should be signed off by a structural engineer in the local market. Contact the flooring engineering department.

Raised Access Flooring

Owner's Manual - February 2015

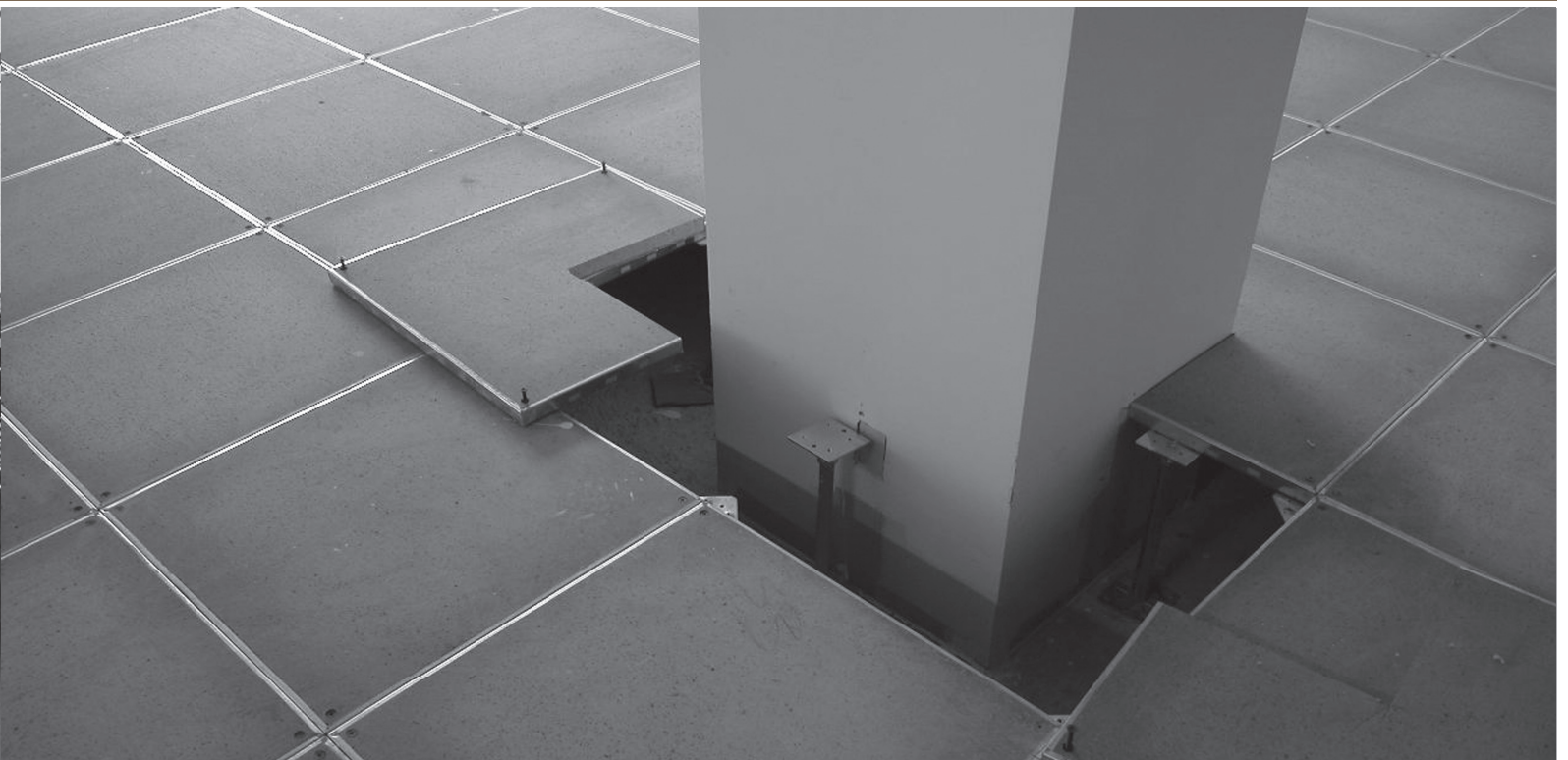

TecCrete: 1250, 1500, 1500sl, 2000, 2500 System

OWNERS MANUAL

Access flooring systems are considered to be interior finishes. The floor should always be protected from the elements and exterior weather conditions. The panels should always be stored or maintained on-site in a secure and dry environment. Areas should be maintained between 40 degrees F and 90 degrees F with a relative humidity range between 35% and 70%. The basic needs are as outlined below.

1.2 Removal and Replacement of Panels

- Use the appropriate lifting device to remove the panels from the floor. The devices will protect individuals and the access floor from injury or damage. Use the bar lifter (G) for cornerlock panels. Use the suction cup lifter (H) for laminate surface panels.
- Take note of the orientation the panel of prior to removing it from the floor. Lift the panel clear of the floor system

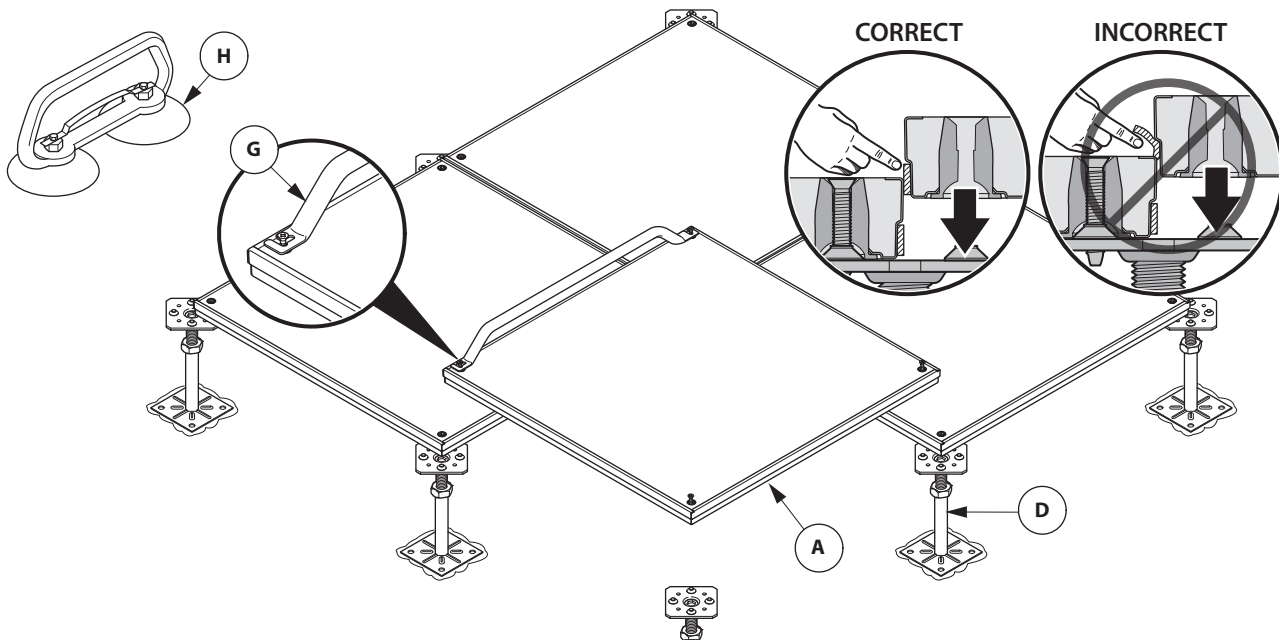

and lay the panel down top side up and out of the way. Remove the lifting device until ready to replace the panel. To replace the panels, place the panel straight onto the pedestal head in the same orientation that it was prior to taking it out of the floor to prevent unlevel floor panels.

- When access to the cavity under the access floor system is required, only those panels directly over the area of work should be removed. It is strongly recommended that panels be removed and replaced by the Haworth Floor Contractor to maintain the best floor performance to make sure panels are replaced in the same orientation to maintain a level floor and replace all screws in the floor.
- Caution should be taken while the floor panels are out of the system not to disturb the adjustment and location of the pedestals nor to bend or break them.
- You must disengage all four corner fasteners prior to removing the panels in a cornerlock system. Be sure when replacing corner-lock panels that all four fasteners are re-engaged and are securely fastened with all four fasteners.
- A torque limited screw gun set at a maximum of 40 in-lbs is recommended to remove and replace panels (See page 9 for proper torque settings)
- Do not kick the panels in place. Do not drop panels in place. Do not use screw drivers or other tools to remove panels or to pry them back in place.
- Do not scrape the airseal off the edge of the panel when replacing panels.
- Do not force panels in place which do not want to go back smoothly into the system. If you have this situation, the panels are out of alignment. Inspect and readjust the adjoining panels to allow smoother re-entry of all panels.
- Failure to adhere to these removal and replacement instructions may result in excessive gaps between panels. It may also cause general misalignment or damage resulting from dropped panels causing broken pedestals or damaged panel edge.

1.2 Cleaning of Access Floor Finishes

TecCrete Installation and Maintenance Guide - 2/15

Access floor systems should be vacuumed periodically to remove any dirt or dust particles and to prevent debris from falling into the plenum or support structure. This is particularly important prior to removal of panels and before replacement. Dirt and dust on the pedestal heads can cause squeaking.

1. **Bare Sealed TecCrete**

Sweep or vacuum floor thoroughly. Damp-mop with warm water and mild multipurpose ammoniated floor cleaner is recommended. When damp mopping clean a small area at a time, wringing the sponge out frequently. When damp mopping a large floor, change water frequently. Rinsing is important. Although detergent directions may say rinsing is unnecessary any detergent film left on a floor will attract dirt.

Do protect the floor from tracked in sand and chemicals by providing mats at entrances. Frequent cleaning of high traffic areas near entrance/exit during winter months may be required.

Don't use wax seal. It is not necessary if the floor has been properly sealed.

Don't flood the floor with liquid or use anything other than a damp mop. Large amounts of water can weaken adhesive.

Don't use strong abrasives or scrapers to remove stains.

2. **Laminate/Vinyl/Airflow Panel Cleaning**

Vacuum floor periodically to remove any dirt or dust particles and to prevent debris from falling into the plenum or support structure. This is particularly important prior to removal of panels and before replacement. Damp-mop with warm water and mild multipurpose ammoniated floor cleaner is recommended. When damp mopping clean a small area at a time. Squeeze the mop dry before mopping. Excess water can cause water to leak below raised floor panels, accumulate dirt and debris into the plenum, and create a slipping hazard. When damp mopping a large floor, change water frequently. Rinsing is important. Although detergent directions may say rinsing is unnecessary any detergent film left on a floor will attract dirt.

Do protect the floor from tracked in sand and chemicals by providing mats at entrances. Frequent cleaning of high traffic areas near entrance/exit during winter months may be required.

Don't use wax seal it is not necessary if the floor has been properly sealed.

Don't flood the floor with liquid, or use anything other than a damp mop. Large amounts of water can weaken adhesive.

Don't use strong abrasives, rotary polishing heads or scrapers to remove stains.

3. **Carpet Finishes**

The basic methods for cleaning and maintaining carpet on access floors are minimally different from those of any other carpet substrate. Vacuuming to remove dirt, spot cleaning for difficult areas, immediately picking up spills, and periodic deep cleaning as required for your use will minimize more serious problems. Listed below are the preferred methods for these operations on specific carpets for access floor panels.

a. **Carpet Tiles**

- The application of carpet tile adhesive must be controlled to prevent problems in access floor installations. Excess adhesive which may penetrate the panel joints creates the following problems: 1) attaches panels to each other requiring the panels to be cut apart for removal, 2) cause squeaks due to dried adhesive between the panels, and 3) may cause the panels surface to oxidize if the adhesive is not dry before the carpet tiles are placed on the panels. Use a sprayable type adhesive to give a light coating on the panel surface or apply the adhesive with a roller which has been leveled off so that globs of adhesive are not deposited on the panel surface and at the module lines to avoid these problems.
- Follow the cleaning instructions below for spot cleaning and vacuuming.
- Vacuums in computer areas should be designed for minimal static accumulation and the filtration system should prevent airborne particles. Damage to computer equipment and disc drives may result from airborne particles.
- Dry foam or dry powders are the preferred methods of cleaning the carpet tile surface. Use minimal amounts of water to prevent water from entering into the plenum space. Excess water in the plenum area can cause

electrical shorts and malfunctions. A second suctioning is desirable to remove excess water from carpet tiles.

- Do not use rotary brush cleaning. They may allow water into the plenum space and will require long periods to dry. Use a pile brush in high traffic areas prior to vacuuming and deep cleaning.
- Use chair mats at desks to prevent early wear.
- Rotate carpet tiles from high to low use areas to extend appearance and life of the carpet tiles.
- Steam and or hot water extraction can cause corrosion, delamination, and electrical hazards. If this method is used, do not allow excess cleaning materials to accumulate.

4. Carpet Maintenance Suggestions

a. Entry Areas

Walk-off mats are the first line of defense in prolonging the life and appearance of carpet surfaces. They should be vacuumed daily for an 8-hour work day; two times daily for a 16-hour work day; and four times daily for an around-the clock work day. These areas should also be deep cleaned according to the following schedule - once a week for an 8- hour or a 16-hour work day and twice a week for an around-the-clock work day.

b. Vacuuming

Daily vacuuming is the most important part of the total carpet care program. Improper or ineffective vacuuming will accelerate wear and will allow dirt and grit to penetrate pile surfaces. All areas should be vacuumed with a dual motor vacuum with a three micron internal filtering system for cleaner air discharged. The vacuum should have an adjustable pile height head, brush wear attachment, and a top loading bag.

Vacuuming frequency will also depend on room area functions. Heavy and moderate traffic areas such as lobbies, entrances, interior traffic aisles should be vacuumed daily. Low traffic areas such as conference rooms, cubicles, and general office spaces should be vacuumed twice weekly.

c. Spot Cleaning

Spots and stains are a detriment to the appearance level and should be promptly taken care of. Do the following on a daily basis:

- Pre-spray with a water based cleaning agent with a pH range of 8.5 to 9.5 and allow it to soak for 10 minutes. Agitate the soiled area with a soft-bristled nylon brush and extract the residue with warm water and a clean rag.
- Do not allow the pre-spray to dry prior to blotting up the stain as it will be ineffective once it is dried.
- Apply Interface Coffee Breaker to coffee stains. Do not blot up Coffee Breaker.

d. Deep Cleaning

Use the dry foam or dry powder methods to minimize the water applied to the floor. Develop a schedule effective for your usage. Follow the instructions on the cleaning solutions label and on the cleaning equipment. As a minimum, the following frequencies are suggested:

- Heavy traffic areas such as lobbies, entrances, and traffic aisles should be done monthly.
- Moderate traffic areas such as interior traffic aisles and medium traffic aisles should be done quarterly.
- Low traffic areas such as conference rooms, cubicles, and general office areas should be done two times per year.

When using the dry foam method, it is recommended to double-extract the cleaning solution a second time without water or cleaner to make sure the excess water is removed from the carpet.

1.3 Recommended Tools List

- Bar lifter for bare TecCrete panels, Suction cups/ carpet lifter
- Battery powered torque limiting screw gun, Black & Decker, Hitachi, or Mikita
- Replacement tips for the screw gun, #2 and #3 Phillips
- No. 2 and #3 Phillips screw drivers
- Vacuum cleaner
- Orbital bayonet saw with carbide grit blades, Milwaukee or Black & Decker Pro Orbital

1. Check the applicable warranty for your project.

1.4 Carpet Maintenance Suggestions

Removal of the pedestal adhesive from the sub floor can be hard to do. Once the adhesive has fully cured to the sub floor removal without damage to the concrete slab can be very labor intensified. We would suggest that the pedestal base plate be heated with a small blow torch or hot air gun to gently heat the surface of the base plate until the adhesive becomes plastic enough to allow the base to become unseated. At that point use mineral spirits or citrus based cleaning componunds to remove any left over adhesive on the sub floor.

1.5 Allowable Lifts to be Used on Access Floor

Please check with the flooring engineering team for the latest list of lifts recommended for use on Haworth Access Floor.

2 WARRANTY PROCEDURE

In the event that a defect is found in Haworth Architectural Interiors products that falls under the standard published warranty, the defects should be reported to Haworth Architectural Interiors in a timely manner. Haworth Architectural Interiors desire is to correct problems experienced in the field and to take any corrective action that may be dictated within or own manufacturing processes to prevent futrue occurrences.

1. Check the applicable warranty for your project.
2. When reporting defects to Haworth Architectural Interiors, the information needed to allow us to process the report is as follows:
 - Include the Haworth Architectural Interiors job number, which can be taken from the order acknowledgment and/or invoice and the date when the product was installed.
 - A description of the defect.
 - The scope of the problem such as quantity (or estimated quantity) of items exhibiting the defect. Depending on the scope of the problem, a field visit from a Haworth representative may be required.
 - Impact of the defect upon ongoing installation work and progress on the job.
3. Before incurring any expense in relation to taking field corrective action on the job, Haworth requires the submission of a written estimate of such costs for prior approval by Haworth Architectural Interiors.
4. Haworth will not accept back charges for cleaning, corrective action, or extra work unless notified and agreed upon in writing prior to the performance of any such work.

(This North American Haworth Product Warranty Policy applies to flooring products manufactured after April 01, 2013)

If a new flooring product purchased or leased from Haworth, Inc. or Haworth, Ltd., (each called “Haworth”) or from an authorized Haworth dealer proves to be defective (as defined below) while the product is still in the possession of the initial purchaser or lessee and if they, within the Applicable Warranty Period, send notice of the defect to Haworth by electronic mail (ctop@haworth.com), then, except as provided below, Haworth will, at Haworth’s option, either repair or replace the product, at Haworth’s expense, or refund the purchase price of the product. Except as provided below, a product shall be considered “defective” if (a) Haworth finds that it is defective in material or workmanship, (b) the product fails to meet any warranted performance for the product that is described below and (c) the defect materially impairs the value of the product to the purchaser or lessee. Each Applicable Warranty Period for a flooring product begins when its installation is complete.

<u>PRODUCTS</u>	<u>APPLICABLE WARRANTY PERIOD</u>
TecCrete®, Tecnika & Praktika floor panels, stringers, pedestal bases and heads	Five Years
Airflow floor panels, Accessories and Power Base™ AI	Three Years
Haworth-applied High Pressure Laminates (HPL) are warranted against delamination from the base panel for	Three Years
TecBase® and TecCrete floor panels with all other Haworth-applied surfaces are warranted against delamination from the base panel for	One Year

A product will not be considered to be defective, and Haworth will not repair, replace it or refund its price if the product (1) is not installed by a Haworth Flooring Contractor or HFC approved Installer; (2) is “Customer’s Own Material” (i.e. material specified by the purchaser or lessee that is not a standard Haworth product offering); (3) is not installed and used as recommended in Haworth’s written Application Guideline or Installation and Maintenance Guides or (4) has been otherwise misused or suffered abusive damage.

A defect in material or workmanship does not include damage to a product, or failure of a product to operate or perform properly or to maintain appearance, caused by (a) normal wear and tear; (b) an Act of God or transportation; (c) a product alteration made without following Haworth’s Application Guideline or Price List; (d) a failure of the color of a flooring product or field-applied material to match or be colorfast with another product or material; (e) the application, inconsistency or performance of a field-applied material or (f) delamination of surfaces that were field-applied.

EXCEPT AS STATED ABOVE, HAWORTH DOES NOT MAKE A WARRANTY AS TO ANY PRODUCT AND, IN PARTICULAR, DOES NOT MAKE A WARRANTY OF MERCHANTABILITY OR OF FITNESS FOR A PARTICULAR PURPOSE. Product repair or replacement or refund of the price, at Haworth’s option, in accordance with this Policy, is the purchaser’s or lessee’s exclusive remedy for a product defect. Haworth shall not have tort liability with respect to a product, and Haworth shall not be liable for any consequential, economic, indirect, special, punitive or incidental damage arising from a product defect.

For all other North American products see the latest published Haworth Product Non-Obsolescence and Warranty Policy by going to www.Haworth.com/Resources/Technical Information/Warranty.

Released April, 2013

PROJECT REGISTRATION WHERE REQUESTED

Project Name: _____	Haworth Job No.: _____
City & State: _____	Date Installation Completed: ____/____/____
Dealer Name: _____	Contact Name: _____
City & State: _____	City & State: _____
Phone Number: _____	Phone Number: _____
Notes: _____	

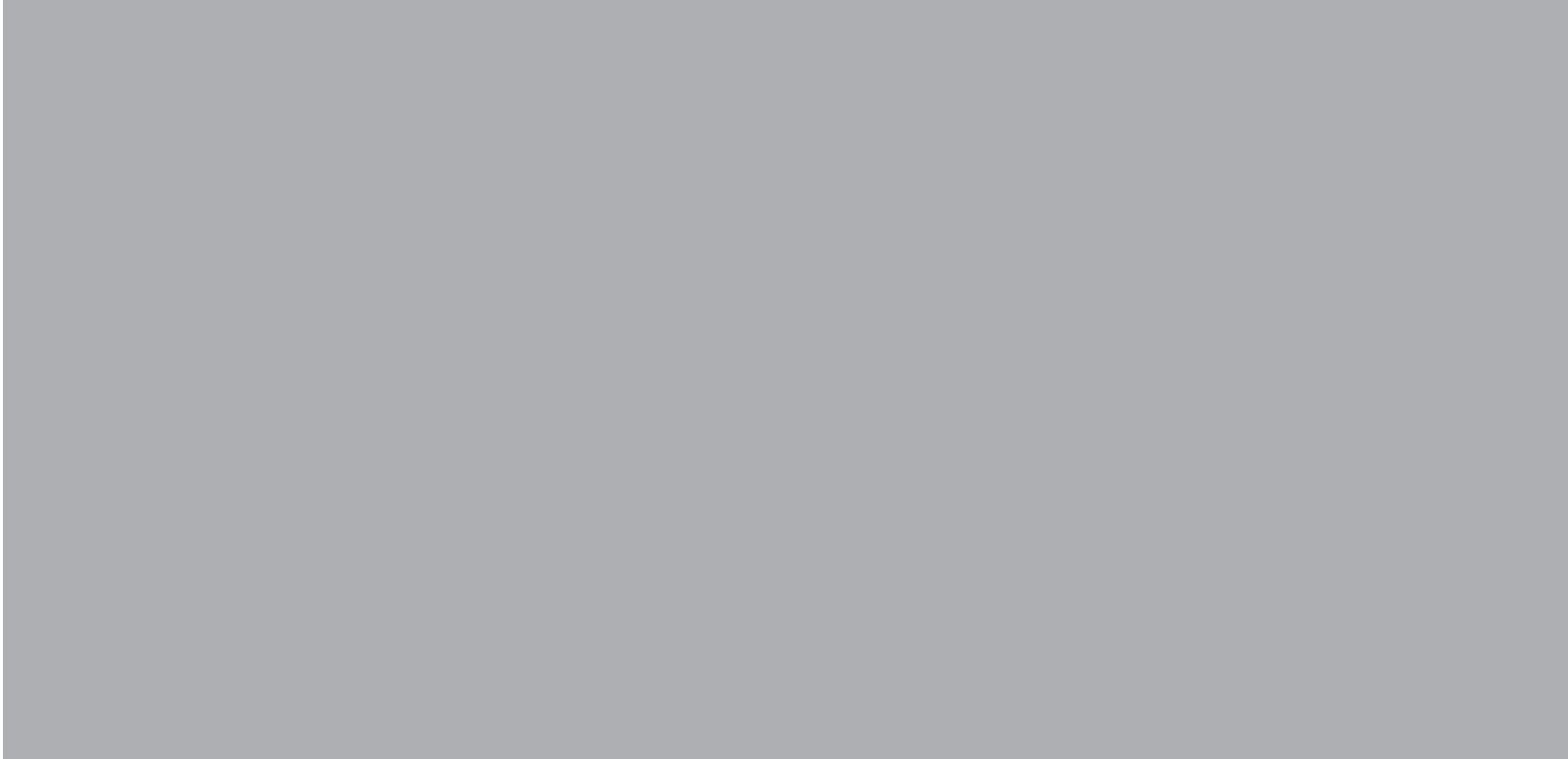

HAWORTH®

For more information call 800.344.2600 or 616.393.3000.

Haworth is a registered trademark of Haworth, Inc.

©Haworth, Inc. 2014 12.14

haworth.com | haworth-europe.com | haworth-asia.com