

■ Universal Overhead Storage

Table of Contents

Universal Overhead Storage

Overhead Cabinet, Off-Module and On-Module Mounted Brackets.....	3
Overhead Shelf, Off-Module and On-Module Mounted Brackets.....	7
Radiused Front, Low & Regular Shelf.....	11
Upmount Brackets.....	13



Assemble units as described herein only. To do otherwise may result in instability. All screws, nuts and bolts must be tightened securely and must be checked periodically after assembly. Failure to assemble properly, or to secure parts may result in assembly failure and personal injury.

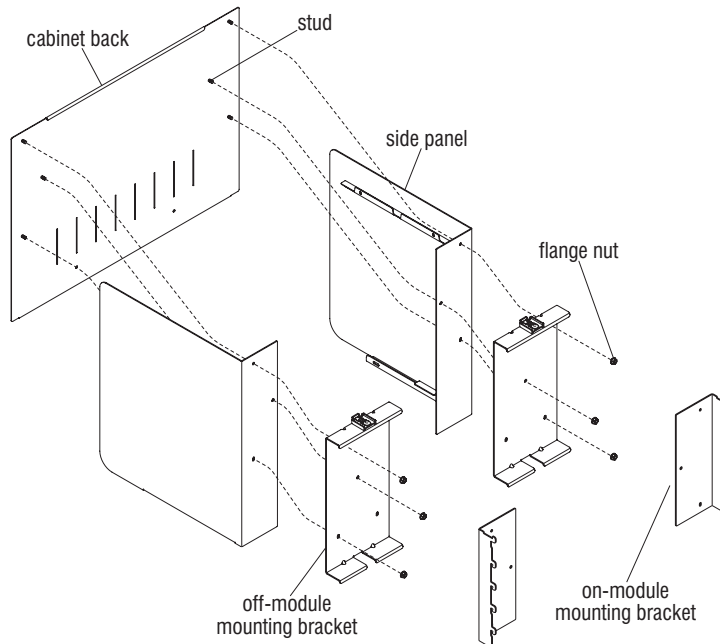

Figure 1

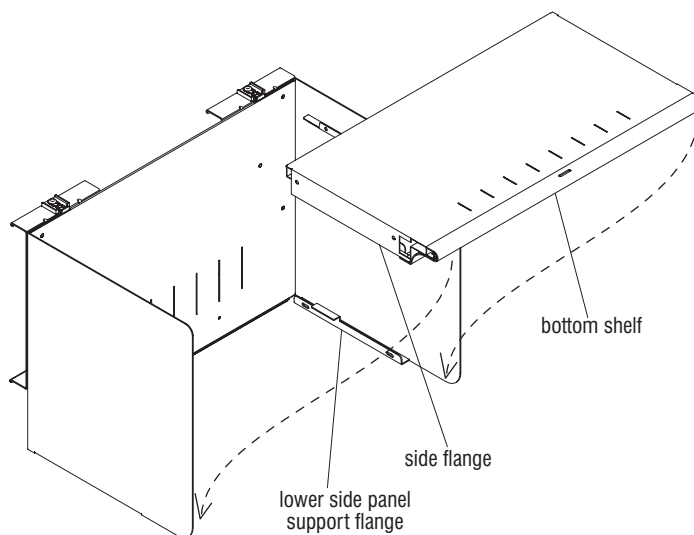

Figure 2

Overhead Cabinet, Off-Module and On-Module Mounted Brackets Assembly

Note: The following overhead cabinet assembly steps refer to both off-module and on-module cabinet types. The type of mounting bracket used determines the type of cabinet being assembled. Also, if cabinets are being pre-assembled and cabinet type (off-module or on-module) is to be determined at a later time, the mounting brackets may be installed at a later time.

1. Assemble the cabinet back, side panels and mounting brackets (off-module or on-module) together by inserting the holes in the side panels (with support flanges facing inward) and mounting brackets through the studs on the cabinet back. Loosely fasten the parts together with six flange nuts as shown. To avoid scratching side panels during bottom shelf assembly (step two), do not tighten flange nuts at this time (Figure 1).
2. Set the bottom shelf into position by locating the side flanges of the bottom shelf over the lower support flanges of the side panels (Figure 2).

■ Universal Overhead Storage

Assembly Instructions



Assemble units as described herein only. To do otherwise may result in instability. All screws, nuts and bolts must be tightened securely and must be checked periodically after assembly. Failure to assemble properly, or to secure parts may result in assembly failure and personal injury.

3. Press the bottom shelf down and adjust until the four screw holes in the bottom shelf side flanges are visible through the slots in the side panel lower support flanges. From under the cabinet, install four #8 x 3/8" self-tapping screws through the slots in the side panel support flanges. Do not tighten completely. At the lower rear of the cabinet, install two #8 x 3/8" self-tapping screws through the back and into the shelf. Do not tighten completely (Figure 3).
4. Place the overhead top assembly over the upper support flanges of the side panels. Tap the top down into place and align the round front edge with the matching radius on the side panel. Install and tighten four #8 x 3/4" self-tapping screws through the four larger oblong holes in the rack and pinion door mechanism inside the top assembly (Figure 4).
5. The recessed door can now be pulled out and lowered to its closed position. Adjust the bottom shelf so the door hangs straight and flush with the end panels. Tighten the four screws under the bottom shelf at this time. Using the door lock key (taped to the inside of the top assembly for shipping), engage the lock cam into the locked position by turning the key clockwise.
6. After the top and shelf have been checked for proper alignment tighten all hardware.

Note: For those users who wish to retain the key in the lock when storing the recessed door, there is a set of door stops that may be installed to prevent door from opening past the key. If the door is opened with the key in the lock, damage to the overhead cabinet and/or a key broken off in the lock may result without door stops.

7. To install recessed door stops, open and store recessed door. Next, pull door out about four inches, enough to avoid interference with

the installation of the door stop. Remove the two rear #8 x 3/8" screws (installed above). Press #8 x 3/4" self-tapping screws through each door stop and fasten the door stops to the flipper door racks on each side of the overhead where the two rear screws were removed (Figure 4).

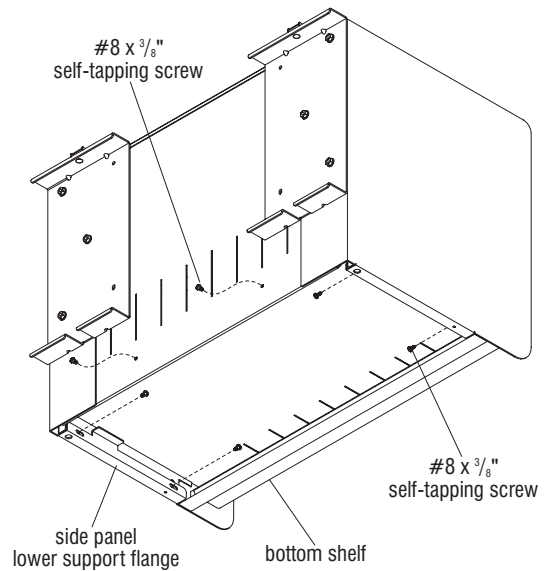

Figure 3

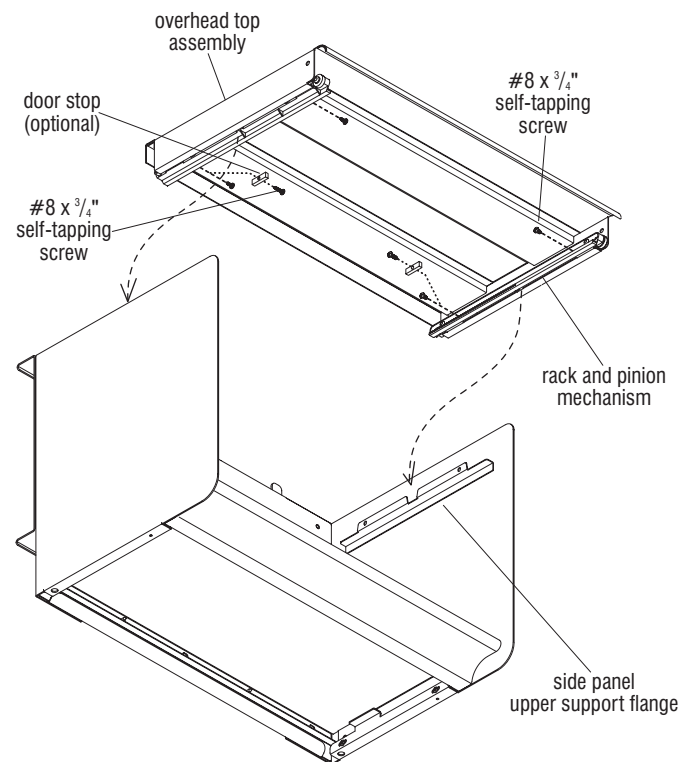

Figure 4



Assemble units as described herein only. To do otherwise may result in instability. All screws, nuts and bolts must be tightened securely and must be checked periodically after assembly. Failure to assemble properly, or to secure parts may result in assembly failure and personal injury.

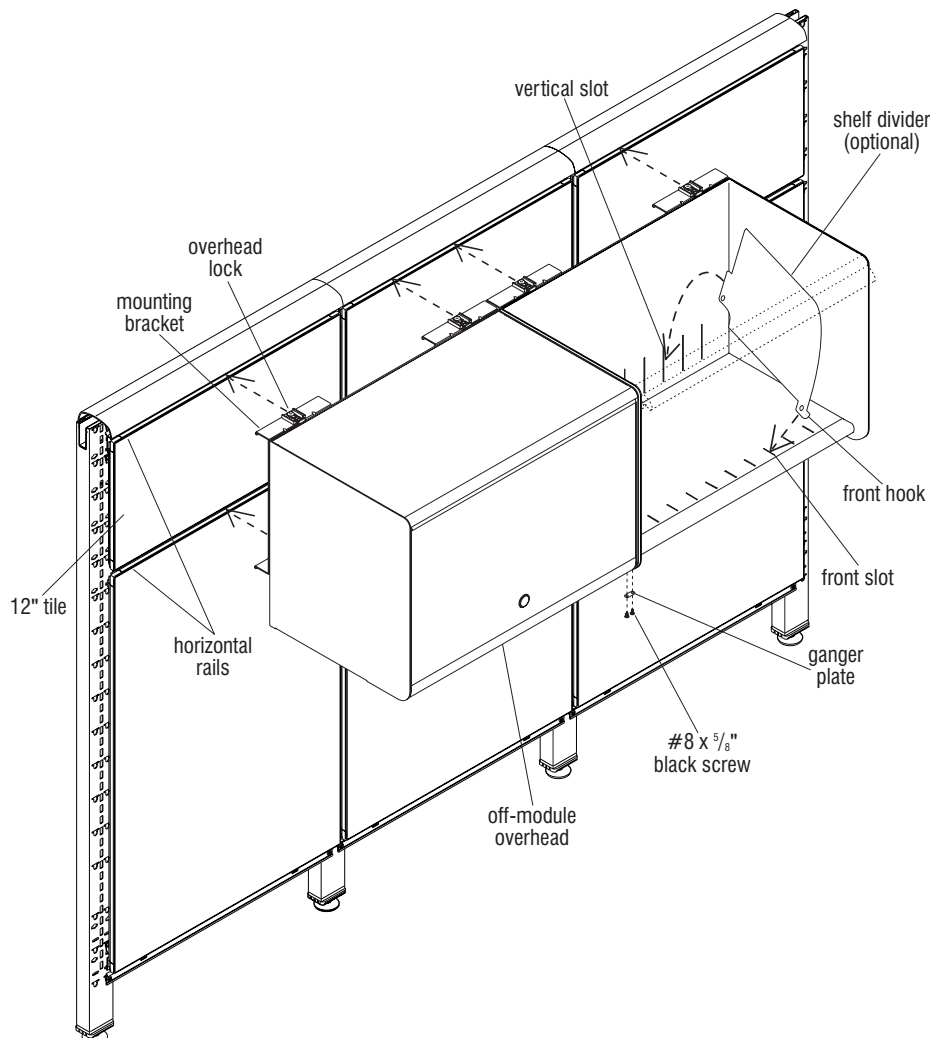

Figure 5

Off-Module Mounted Cabinets

8. Off-module mounted cabinets can only be hung with the top aligned with the top of a 12" tile. To make hanging the overhead easier, remove the tile or top cap directly above the overhead. With the overhead locks pulled out (toward the front of the cabinet), hang the top and bottom of the mounting bracket into the tracks of the panel's horizontal rail. Make sure the cabinet is hanging on the horizontal rail and not on the tile. After the cabinet is hung in the track, move it to the desired position by gently lifting up while sliding it. Secure the cabinet on the tracks by pressing the overhead locks into the track (Figure 5).

Caution: To remove the cabinet assembly from the panel, push the bottom of the cabinet straight up about 1/4" and rotate the bottom out toward you to about 30°. Pull the cabinet straight out and down. Do not force the side panel, damage to the top tooth may result.

9. When two or more cabinets are installed next to each other, secure them together with a ganger plate. Fasten a ganger plate to the cabinet bottoms with two #8 x 5/8" black screws (Figure 5).
10. To install shelf dividers (optional), first place the front hook of the divider into the front slot of the shelf. Then rotate the rear of the divider down until the the tab snaps into the vertical slot in the cabinet back (Figure 5). To remove the divider, press lightly on the cabinet back to release the rear tab and rotate it out.

■ Universal Overhead Storage

Assembly Instructions



Assemble units as described herein only. To do otherwise may result in instability. All screws, nuts and bolts must be tightened securely and must be checked periodically after assembly. Failure to assemble properly, or to secure parts may result in assembly failure and personal injury.

On-Module Mounted Cabinets

11. The mounting brackets have integral teeth that engage in the vertical furniture hanging slots in the panel frame. Locate the on-module cabinet at the height that is desired on the panel. Engage the antislidgement tooth into the panel frame by holding the cabinet bottom out about 30°, then rotate the cabinet bottom down to engage all the remaining teeth. When all teeth are engaged, press down on the cabinet to lock in place (Detail A).

Caution: To remove the cabinet assembly from the panel, push the bottom of the cabinet straight up about 1/4" and rotate the bottom out toward you to about 30°. Pull the cabinet straight out and down. Do not force the side panel, damage to the top tooth may result.

12. When two or more cabinets are installed next to each other, secure them together with a ganger plate. Fasten a ganger plate to the cabinet bottoms with two #8 x 5/8" black screws (Figure 6).
13. To install shelf dividers (optional), first place the front hook of the divider into the front slot of the shelf. Then rotate the rear of the divider down until the the tab snaps into the vertical slot in the cabinet back (Figure 6). To remove the divider, press lightly on the cabinet back to release the rear tab and rotate it out.

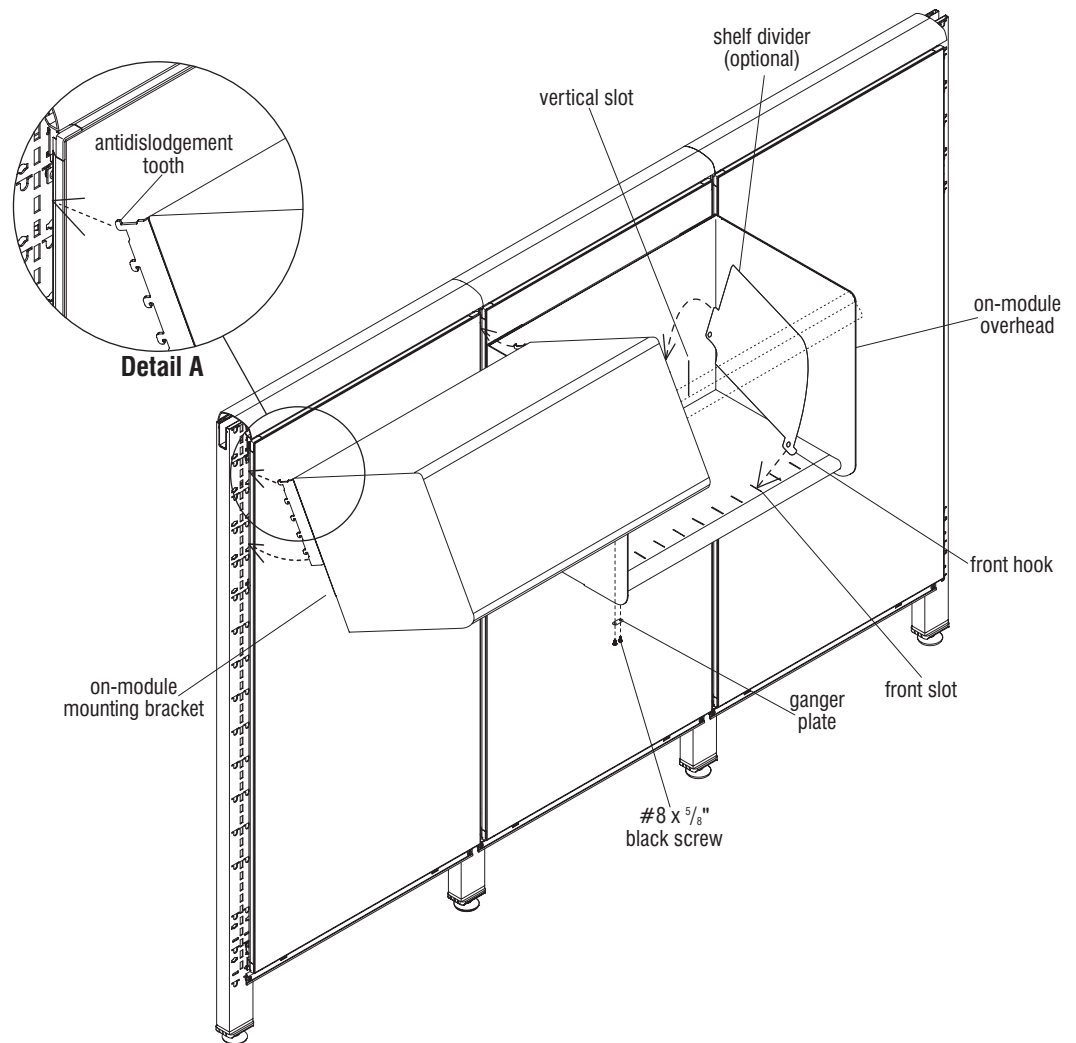

Figure 6



Assemble units as described herein only. To do otherwise may result in instability. All screws, nuts and bolts must be tightened securely and must be checked periodically after assembly. Failure to assemble properly, or to secure parts may result in assembly failure and personal injury.

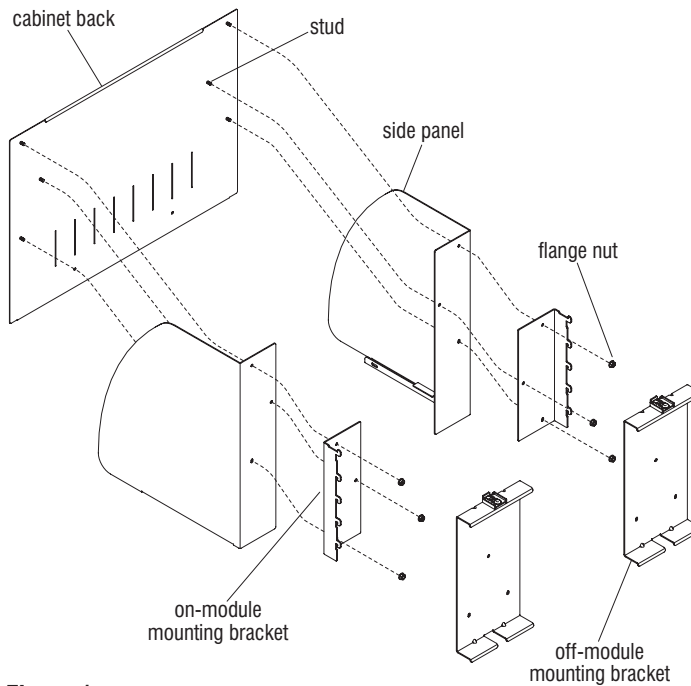

Figure 1

Overhead Shelf, Off-Module and On-Module Mounted Brackets

Note: The following overhead shelf assembly steps refer to both off-module and on-module shelf types. The type of mounting bracket used determines the type of shelf being assembled. Also, if shelves are being pre-assembled and shelf type (off-module or on-module) is to be determined at a later time, the mounting brackets may be installed at a later time.

1. Assemble the shelf back, side panels and mounting brackets (off-module or on-module) together by inserting the holes in the side panels (with support flanges facing inward) and mounting brackets through the studs on the shelf back. Loosely fasten the parts together with six flange nuts as shown. To avoid scratching side panels during shelf assembly (step two), do not tighten flange nuts at this time (Figure 1).
2. Set the shelf into position by locating the side flanges of the bottom shelf over the lower support flanges of the side panels (Figure 2).

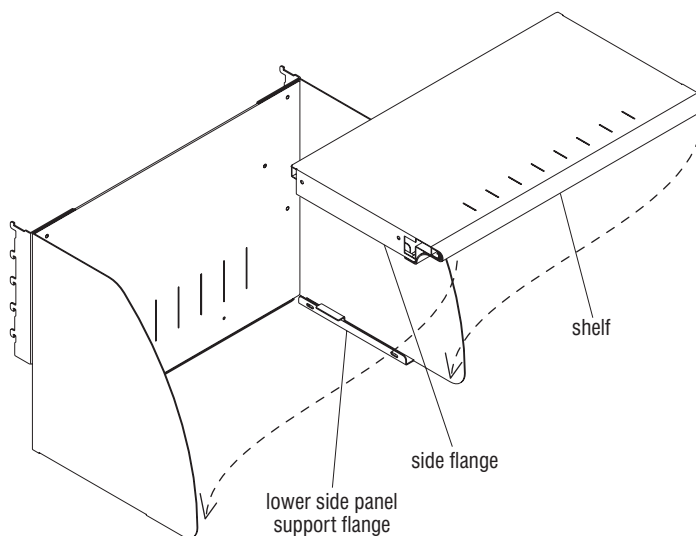

Figure 2

■ Universal Overhead Storage

Assembly Instructions



Assemble units as described herein only. To do otherwise may result in instability. All screws, nuts and bolts must be tightened securely and must be checked periodically after assembly. Failure to assemble properly, or to secure parts may result in assembly failure and personal injury.

3. Press the shelf down and adjust until the four screw holes in the shelf's side flanges are visible through the slots in the side panel support flanges. From under the shelf, install four #8 x $\frac{3}{8}$ " self-tapping screws through the slots in the side panel support flanges. Do not tighten completely. At the lower rear of the shelf, install two #8 x $\frac{3}{8}$ " self-tapping screws through the back and into the shelf. Tighten all fasteners at this time (Figure 3).

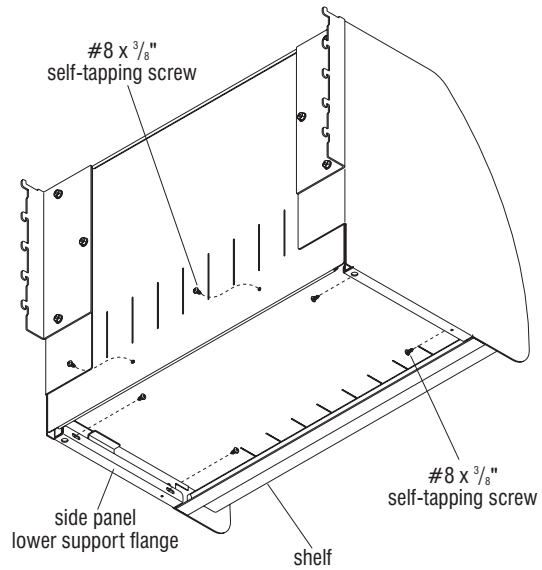

Figure 3



Assemble units as described herein only. To do otherwise may result in instability. All screws, nuts and bolts must be tightened securely and must be checked periodically after assembly. Failure to assemble properly, or to secure parts may result in assembly failure and personal injury.

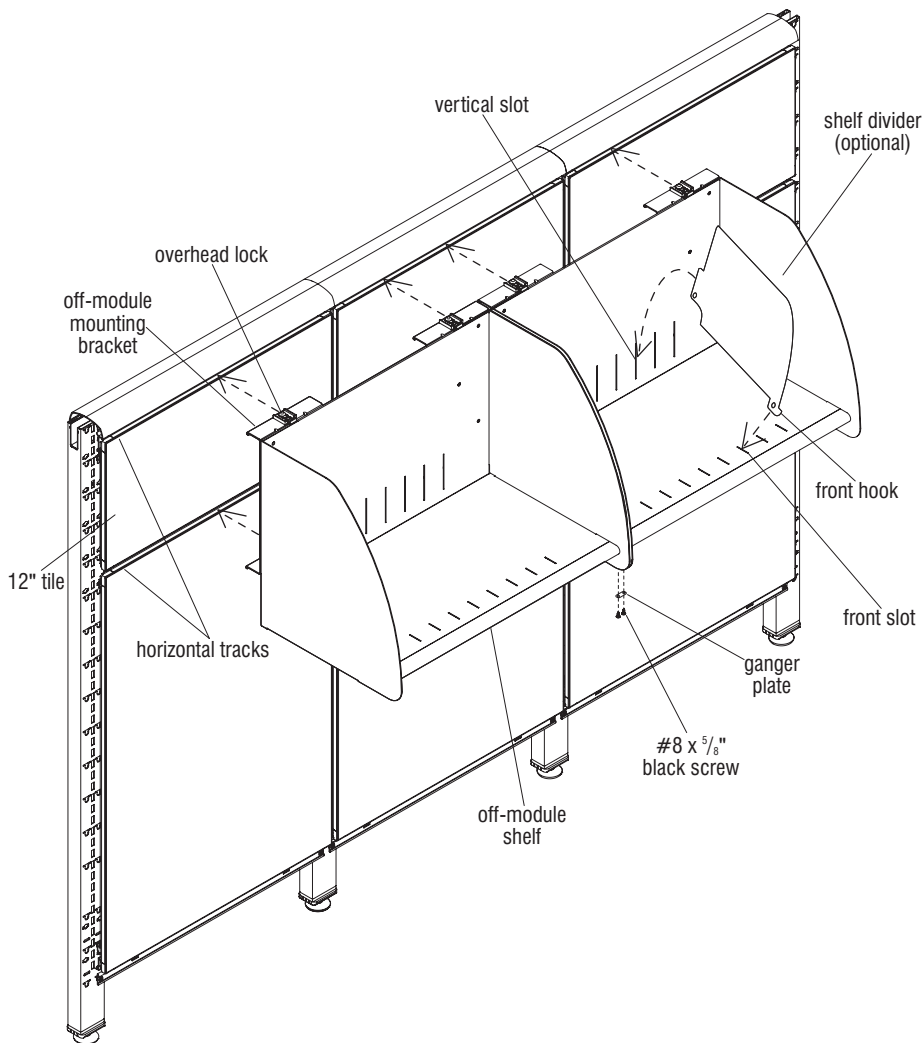

Figure 4

Off-Module Mounted Cabinets

4. Off-module shelves can only be hung with the top aligned to a 12" tile. To make hanging the overhead easier, remove the top cap or tile directly above the overhead. With the overhead locks pulled out (toward the front of the shelf), hang the top and bottom of the mounting bracket into the tracks of the panel's horizontal rail. Make sure the shelf is hanging on the horizontal rail and not on the tile. After the shelf is hung in the track, move it to the desired position by gently lifting up while sliding it. Secure the shelf on the tracks by pressing the overhead locks into the track (Figure 4).

Caution: To remove the shelf assembly from the panel, push the bottom of the shelf straight up about 1/4" and rotate the bottom out toward you to about 30°. Pull the shelf straight out and down. Do not force the side panel, damage to the top tooth may result.

5. When two or more shelves are installed next to each other, secure them together with a ganger plate. Fasten a ganger plate to the shelf bottoms with two #8 x 5/8" black screws (Figure 4).
6. To install shelf dividers (optional), first place the front hook of the divider into the front slot of the shelf. Then rotate the rear of the divider down until the the tab snaps into the vertical slot in the shelf back (Figure 4). To remove the divider, press lightly on the shelf back to release the rear tab and rotate it out.

■ Universal Overhead Storage

Assembly Instructions



Assemble units as described herein only. To do otherwise may result in instability. All screws, nuts and bolts must be tightened securely and must be checked periodically after assembly. Failure to assemble properly, or to secure parts may result in assembly failure and personal injury.

On-Module Mounted Cabinets

The mounting brackets have integral teeth that engage in the vertical furniture hanging slots in the panel frame. Locate the on-module shelf at the height that is desired on the panel. Engage the antislodgement tooth into the panel frame by holding the shelf bottom out about 30°, then rotate the shelf down to engage all the remaining teeth. When all teeth are engaged, press down on the shelf to lock in place (Detail A).

Caution: To remove the shelf assembly from the panel, push the bottom of the cabinet straight up about 1/4" and rotate the bottom out toward you to about 30°. Pull the shelf straight out and down. Do not force the side panel, damage to the top tooth may result.

7. When two or more shelves are installed next to each other, secure them together with a ganger plate. Fasten a ganger plate to the shelf bottoms with two #8 x 5/8" black screws (Figure 5).
8. To install shelf dividers (optional), first place the front hook of the divider into the front slot of the shelf. Then rotate the rear of the divider down until the tab snaps into the vertical slot in the shelf back (Figure 5). To remove the divider, press lightly on the shelf back to release the rear tab and rotate it out.

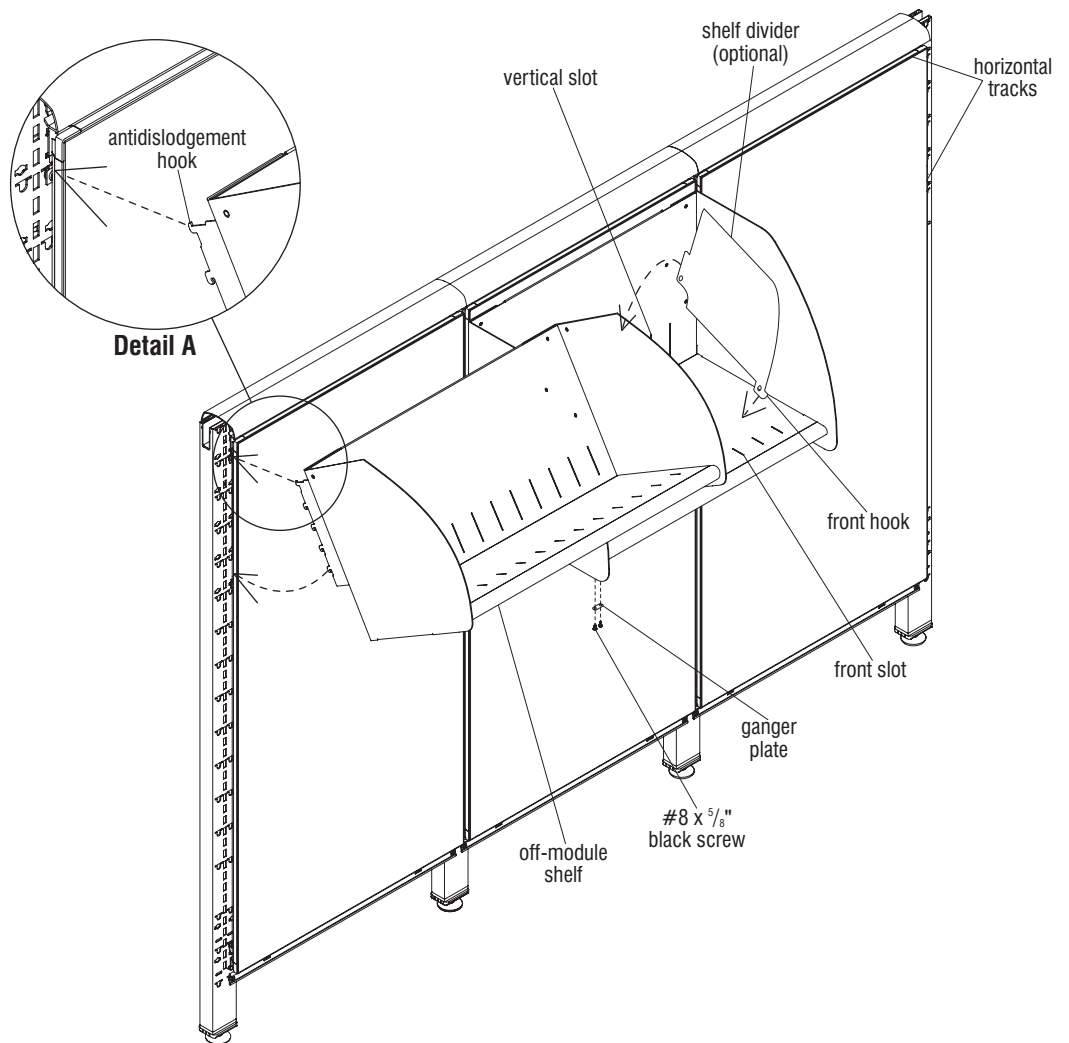



Figure 5



Assemble units as described herein only. To do otherwise may result in instability. All screws, nuts and bolts must be tightened securely and must be checked periodically after assembly. Failure to assemble properly, or to secure parts may result in assembly failure and personal injury.

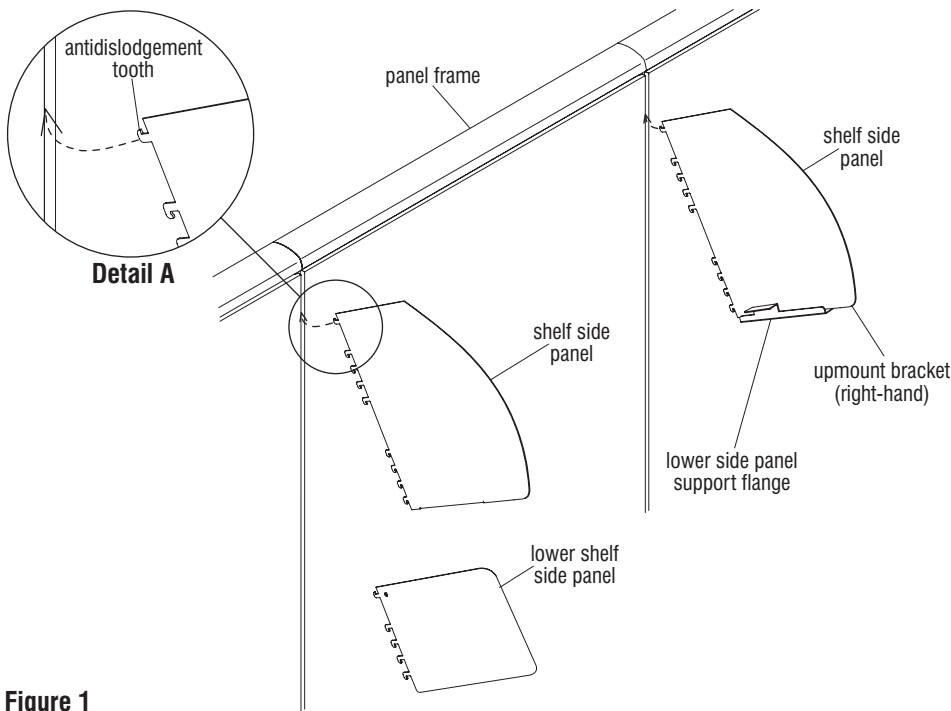

Figure 1

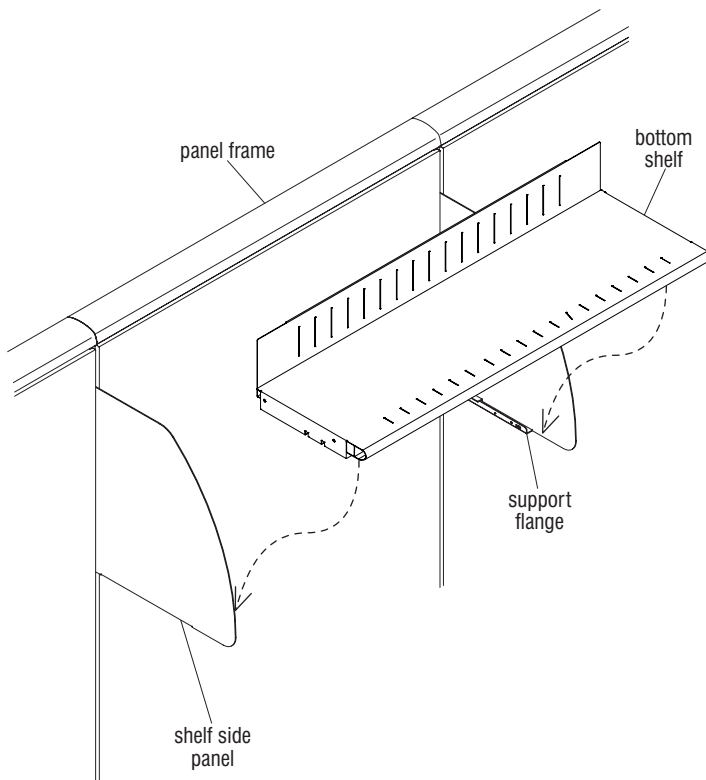

Figure 2

Radiused Front, Low & Regular Shelf

1. Position the two shelf side panels with the support flanges facing inward. Locate the side panels at the height that is desired on the panel. The side panels have integral teeth that engage in the furniture hanging slots in the panel frame (Figure 1).
2. Engage the antidislodgement tooth into the panel frame by holding the side panel out from the bottom about 30°, then rotate the side panel down to engage all the remaining teeth. When all the teeth are engaged, press down on the side panel to lock in place. Repeat for the second side panel (Detail A).

Note: Using the top most slot in the frame allows the unit to be mounted flush with the top of the panel.

Caution: To remove the side panel from the panel frame, push from the bottom of the panel straight up, approximately 1/4". Grasp the bottom of the side panel and rotate out toward you above 30°. Pull the side panel straight out. Do not force the side panel. Damage to the top tooth may result.

Note: Failure to properly install shelf side panel may cause shelf failure and personal injury.

3. Place the side flanges of the bottom shelf over the support flanges on the bottom of the side panel (Figure 2).

■ Universal Overhead Storage

Assembly Instructions



Assemble units as described herein only. To do otherwise may result in instability. All screws, nuts and bolts must be tightened securely and must be checked periodically after assembly. Failure to assemble properly, or to secure parts may result in assembly failure and personal injury.

4. Pull the shelf down and adjust until all screw holes in the side flanges are visible through the slots in the support flanges. Install four #8 x 3/8" self-tapping screws through the slots in the side panel support flanges (Figure 3).
5. When two or more shelves are installed next to each other, fasten them together with a ganger plate. Secure ganger plate to the shelf bottoms with two #8 screws (Figure 4).
6. To install shelf divider (optional), first place front hook into slot of shelf bottom, then rotate rear of divider until tab snaps into vertical slot of shelf back. To remove divider, press lightly on shelf back to release rear tab and rotate out (Figure 5).

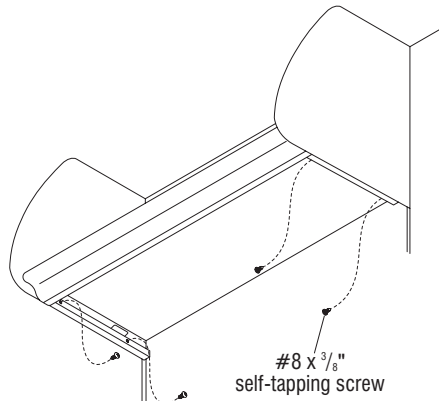

Figure 3

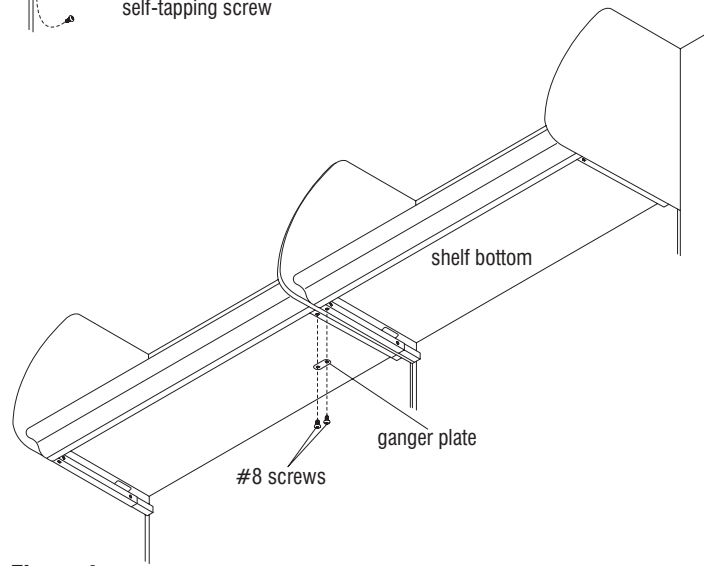

Figure 4

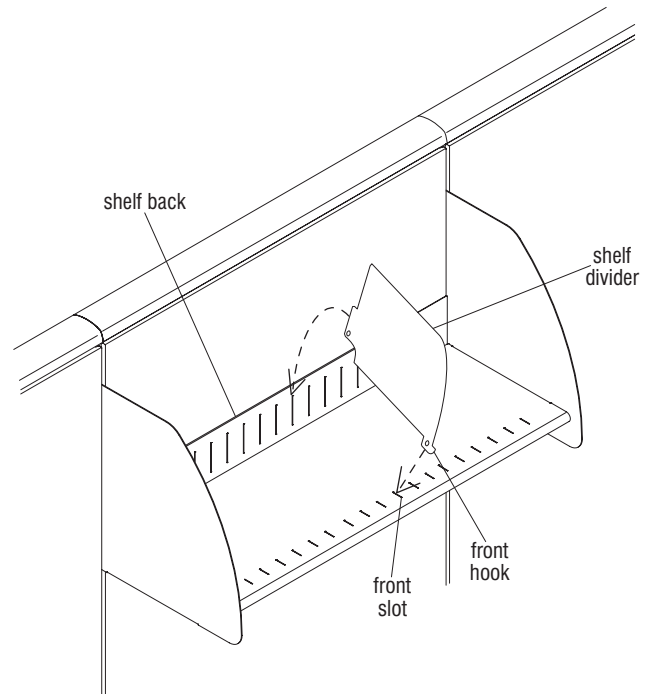

Figure 5



Assemble units as described herein only. To do otherwise may result in instability. All screws, nuts and bolts must be tightened securely and must be checked periodically after assembly. Failure to assemble properly, or to secure parts may result in assembly failure and personal injury.

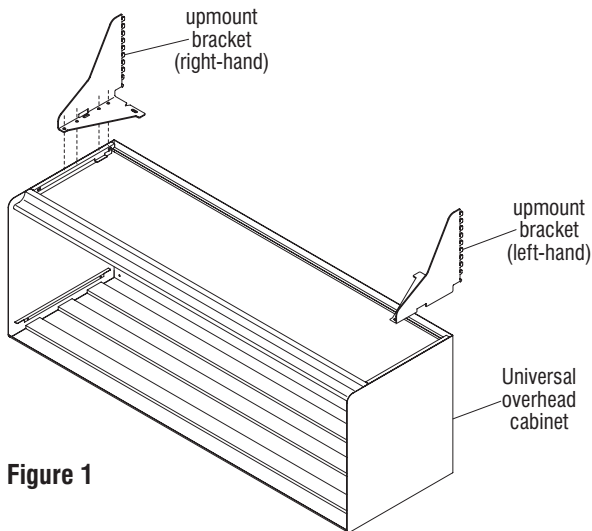
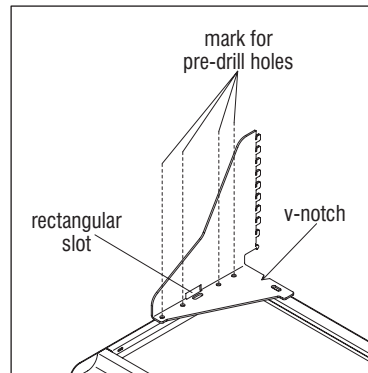

Figure 1



Detail A

Universal Upmount Brackets

1. Turn fully assembled Universal overhead cabinet onto its top (Figure 1).
2. Position brackets onto bottom of overhead so that the "point" of the v-notch aligns with the back of the overhead such that $\frac{1}{2}$ " overhangs the back of the cabinet, also the rectangular slot should align with the side of the overhead such that $\frac{1}{4}$ " of bracket overhangs the side of the cabinet (Figure 1 & Detail A).
3. Using the correctly positioned upmount bracket as a template, mark the four mounting locations to the underside of the cabinet. Remove the bracket and drill four $\frac{1}{8}$ " diameter pilot holes into bottom ridge of the cabinet. Repeat the process for bracket at other side of cabinet (Figure 1 & Detail A).

Note: Do not attach brackets to the cabinet at this time.

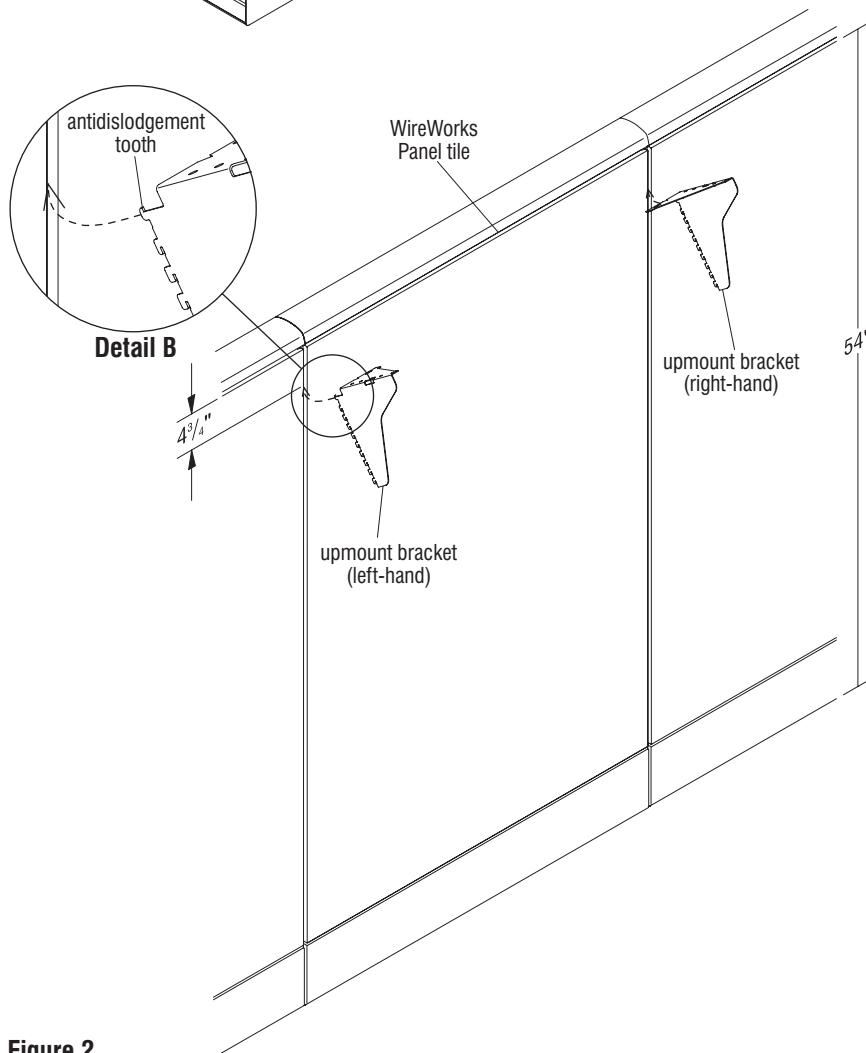

Figure 2

4. Determine the height for the Universal cabinet using upmount brackets. The top of the bracket will locate the bottom of the cabinet at that height. For 54" tall WireWorks panels, locating the top antidislodgement tooth in the sixth slot from the top of the frame (so there is $4 \frac{3}{4}$ " space to the top of the panel tile), will position the bottom of the overhead cabinet at 20" above a 29" high worksurface (Figure 2).
5. To install upmount bracket, engage the top antidislodgement tooth into the panel frame by holding the bottom of the upmount bracket out about 30°, then rotate the bracket down to engage all the remaining teeth. When all teeth are engaged, press down on the upmount bracket to lock in place. Repeat for bracket at other side (Figure 2).

■ Universal Overhead Storage

Assembly Instructions



Assemble units as described herein only. To do otherwise may result in instability. All screws, nuts and bolts must be tightened securely and must be checked periodically after assembly. Failure to assemble properly, or to secure parts may result in assembly failure and personal injury.

6. Carefully position overhead cabinet or shelf on top of brackets aligning the four round holes in each bracket with the four $\frac{1}{8}$ " diameter pilot holes in the cabinet (Figures 3 & Detail C).
7. Insert and tighten all eight $10 \times \frac{1}{2}$ " self-tapping screws (Figures 3 & Detail C).

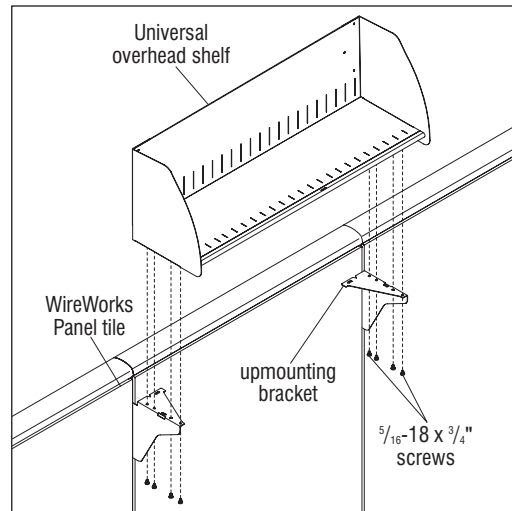

Detail C

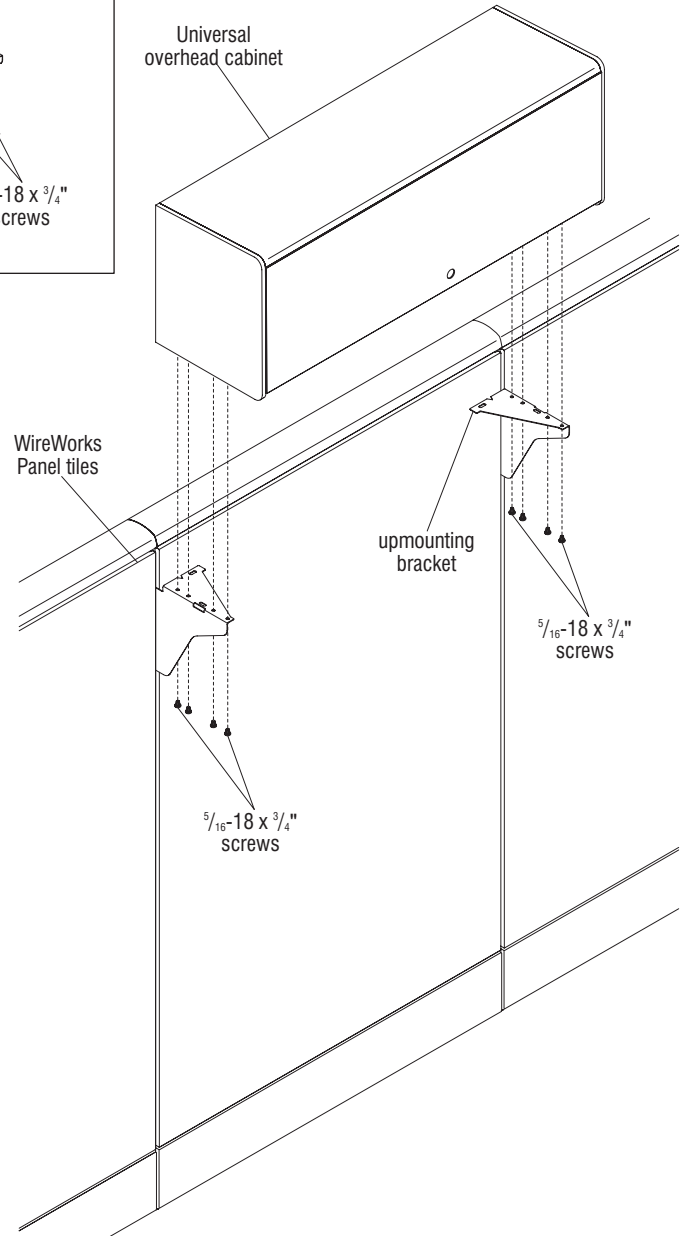

Figure 3



Assemble units as described herein only. To do otherwise may result in instability. All screws, nuts and bolts must be tightened securely and must be checked periodically after assembly. Failure to assemble properly, or to secure parts may result in assembly failure and personal injury.

KI
1330 Bellevue Street
P.O. Box 8100
Green Bay, Wisconsin 54308-8100
1-800-424-2432
www.ki.com

KI is a registered trademark
of Krueger International, Inc.

© 2016 Krueger International, Inc.
All Rights Reserved
Code KI-62715/KI/PDF/0116

