

Assembly Instructions

Unite® Panel System

November 2016



---



---



---



---



---



---



---



---



---



---

■ Unite® Panel System - Table of Contents  
Assembly Instructions

 <b>WARNING</b>	Rare Earth Magnets used with this product. The magnets can be harmful to pacemaker wearers and others with medical devices. <b>Pacemaker wearers should stay at least one foot away from the steel tiles.</b>
--	---

Frame Installation.....	3
Frame to Genius Installation.....	20
Electrical Installation.....	23
Electrical Infeed Installation.....	30
Tile Installation.....	38
Trim Installation .....	46
Glass Topper Installation.....	55
Worksurface Installation.....	58
Worksurface with Pedestal Support Installation.....	72



Assemble units as described herein only. To do otherwise may result in instability. All screws, nuts and bolts must be tightened securely and must be checked periodically after assembly. Failure to assemble properly, or to secure parts may result in assembly failure and personal injury.

**Panel Frame Overview**

Unite Panel System frames ship to the site as welded structures of various heights and widths. Frames easily connect to each other, using a single size bolt/washer and two intersection components. Each frame has two height-adjustable glides pre-installed at the base of the panel to help level the panel system. The panel assembly becomes the structure for attaching tiles, trim, power/data components, storage and many other accessories.

Your space-planning layout outlines the panel type, and configuration. This installation manual instructs how to assemble the Unite Panel components into a panel system.

Unite Panel System uses two panel frame designs, the "Elevated Base Frame" and the "Raceway Base Frame" (Figure 1). Assembled and installed, the Elevated Base Frames

have a 6" opening under the lower horizontal rail, between the vertical posts. Raceway Base Frames have brackets installed under the lower horizontal rail. Brackets are used for mounting electrical harnesses and base raceway covers to the frames. Raceway covers fill the 6" opening to the floor and allow for power and data outlets.

**Intersection Connection Overview**

For simplicity, all Unite frame intersections are secured using one bolt size: 3/8-16 x 1 1/4" hex head bolt (48.0115). All intersection connections use this same bolt. A 3/8-16 k-lock nut and flat washers may be used in some situations (Figure 2).

**Connector Block with Spacer Plate**

All intersection and some in-line intersections require the use of connector blocks. Connector blocks attach to the panel frame using a single 3/8-16 x 1 1/4" hex head bolt (48-0115) and a flat washer.

**Important:** Connector blocks are now pre-assembled with spacer plates at each of the four faces. When attaching the connector block to a panel, it is important that the spacer plate be left in the "up" position. The spacer plates maintain the 3 1/2" standard modularity of the Unite panel system. When installing trim, the spacer plates must be bent straight "down" so the trim can sit flush with the connector block.

**Reconfiguration:** If an intersection must be reconfigured; the spacer plate can be lifted "up" and returned flush with the connector block.

**End-of-Run Clips**

Trim, installed at the end of panels, connect to end-of-run trim clips which must be installed prior to installing tiles. End-of-run trim clips attach to panel ends using a single 3/8-16 x 3/4" hex head bolt and 3/8-16 K-Lock nut per clip (Figure 2).

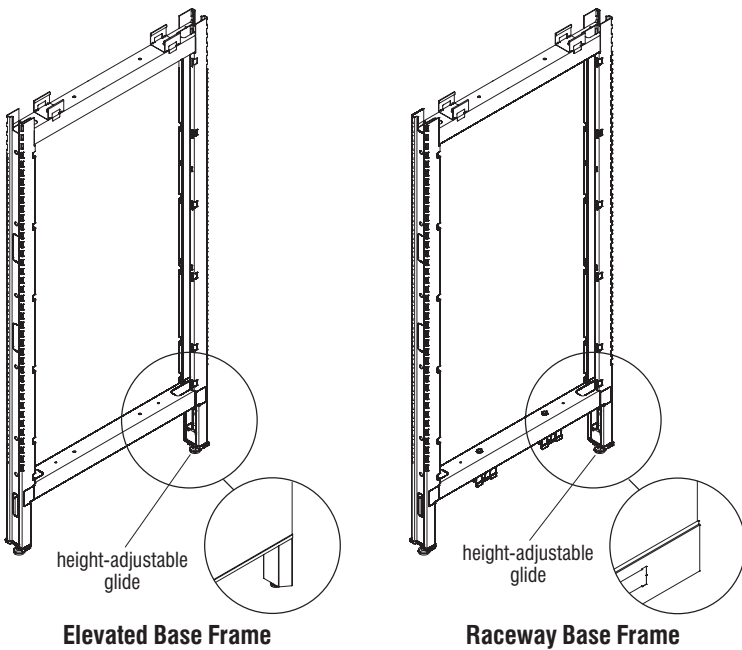

Figure 1

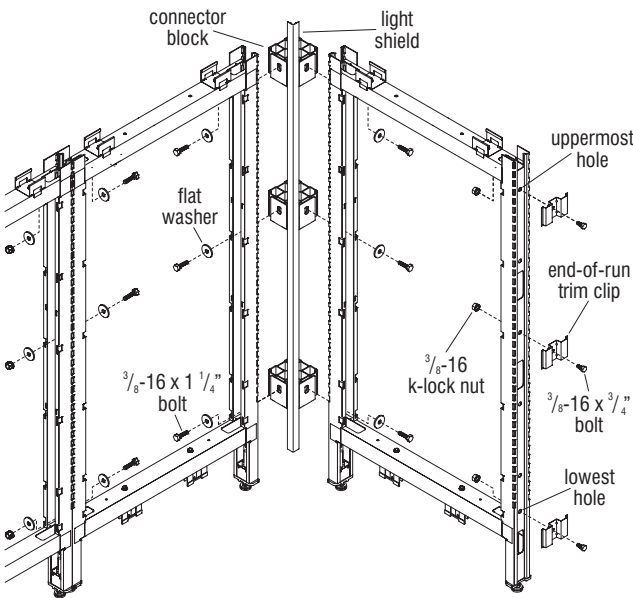
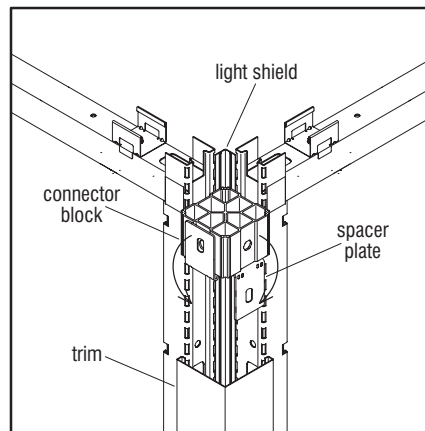

Figure 2 - Parts Identification



Detail A

# Unite® Panel System - Frame Installation

## Assembly Instructions



Assemble units as described herein only. To do otherwise may result in instability. All screws, nuts and bolts must be tightened securely and must be checked periodically after assembly. Failure to assemble properly, or to secure parts may result in assembly failure and personal injury.

### Intersection Frame Assembly

**Important:** It is very important to level the panel system. Know and mark all high and low spots on the floor, and make sure to twist adjustable glides out appropriate to floor conditions. Always begin assembling panels together at the highest point of an un-even floor, with the glides adjusted 1/2" from the base of the frame.

**Note:** If pre-configured stacking panels are specified, different guidelines apply for the placement of connector blocks. See pages 9 & 10.

1. Assembly of Unite Panel System frames should begin at an intersection (90° or 120°). Per the space-planning layout, locate two panel frames to be joined together.

**Note:** If two panel frames being joined are of different heights, begin with the lower-height panel, as the shorter panel determines the number of connector blocks required. Go to page 8 instructions and see Figure 8, at this time.

### Same-Height Frame Intersections

2. Loosely attach connector blocks to one vertical panel frame using one 3/8-16 x 1 1/4" hex head bolt and large flat washer per connector block (Figures 3, 4 & 5). Attach one connector block at the lowest mounting hole in the frame, one at the highest, and the third approximately 30" from the floor, near beltline height. If the panel frame is only 32" high, use only two connector blocks, one at the top and one at the bottom (See Detail C - "Panel Connector Block Charts," page 5).
3. Have one person hold the panel frame (with connector blocks). Then attach the next panel frame to the first panel frame using hex head bolts and flat washers. Hand-tighten hardware until all intersection connections are made (Figures 3, 4 & 5).

4. Tighten all hex bolts at intersections, then level the panel frames, twisting the height-adjustable glides in or out. (Figures 3, 4 & 5).

**Note:** Light shields are available in 48, 64 & 80" nominal lengths. The above light shield lengths do not require cutting when paired with the same nominal height panel frame.

5. Begin light shield installation by first locating the nominal length plastic light shield that matches the nominal height panel frame it installs adjacent to. For nominal height 32, 40 & 56" panels, locate a light shield that is longer than, but closest to the nominal frame height. When required (for 32, 40 & 56" panel heights), cut the longer plastic light shield to size. See Detail A - "Light Shield Table," page 5 to determine proper cut length.

6. Plastic light shields must be installed after intersections are assembled and all bolts are tightened into connector blocks. Measure and make a mark that is 5/16" down from the top of the vertical frame post (Detail B, page 5). Using the proper length light shield, position the top of the shield at that 5/16" mark. Snap the light shield into the corner of each connector block such that you hear a "click", ensuring that the light shield is snug at each connector block.

**Note:** The bottom of the light shield should fit flush with the bottom trim when trim is installed. The top of the light shield should fit nearly flush with the underside of an intersection top cap when it is installed later.

**Tip:** A top cap can be temporarily installed to help locate the top of the light shield. Snap the light shield in place such that the top of the shield is flush with the bottom of an installed top cap.

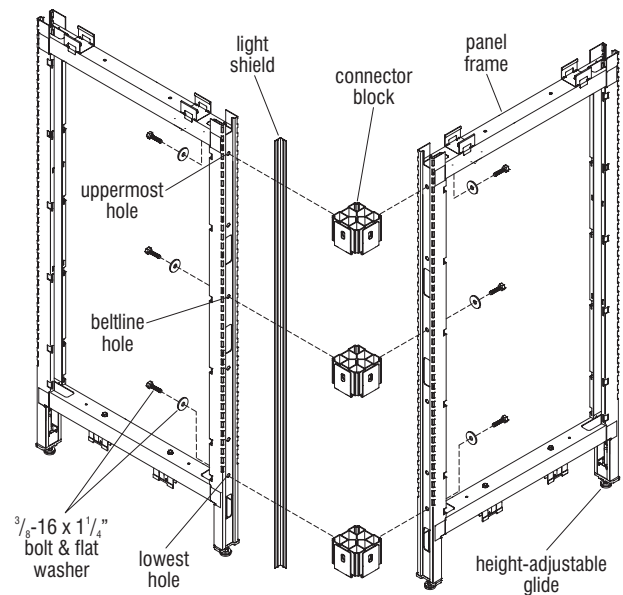

Figure 3 - Two-Panel Intersection

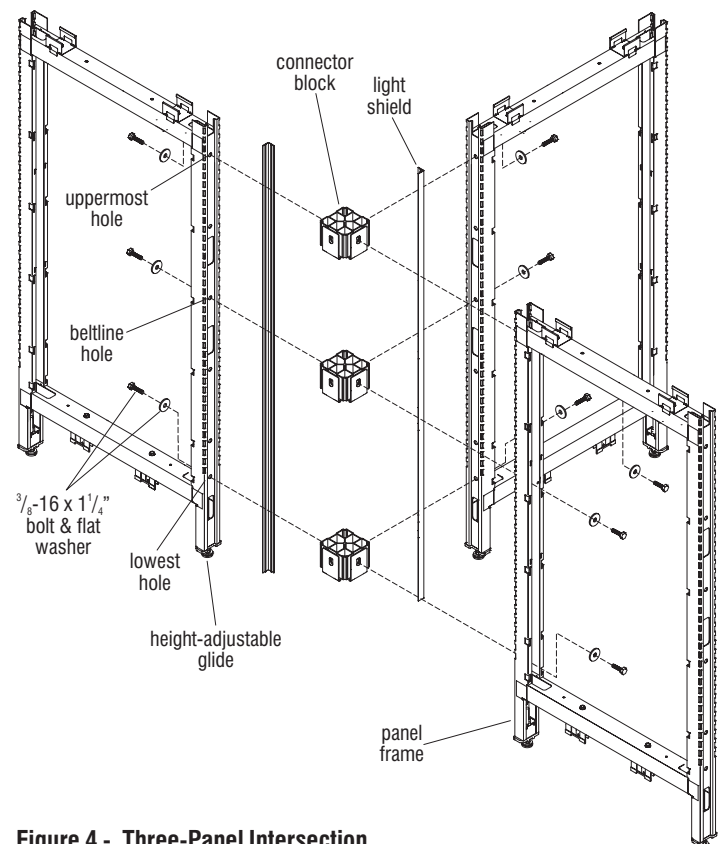

Figure 4 - Three-Panel Intersection



Assemble units as described herein only. To do otherwise may result in instability. All screws, nuts and bolts must be tightened securely and must be checked periodically after assembly. Failure to assemble properly, or to secure parts may result in assembly failure and personal injury.

Light Shield Table

Nominal Panel Height	Nominal Light Shield	Actual Length
32"	48"	31 <sup>3</sup> / <sub>4</sub> "
40"	48"	39 <sup>3</sup> / <sub>4</sub> "
48"	48"	No cutting required
56"	64"	55 <sup>3</sup> / <sub>4</sub> "
64"	64"	No cutting required
80"	80"	No cutting required

Detail A

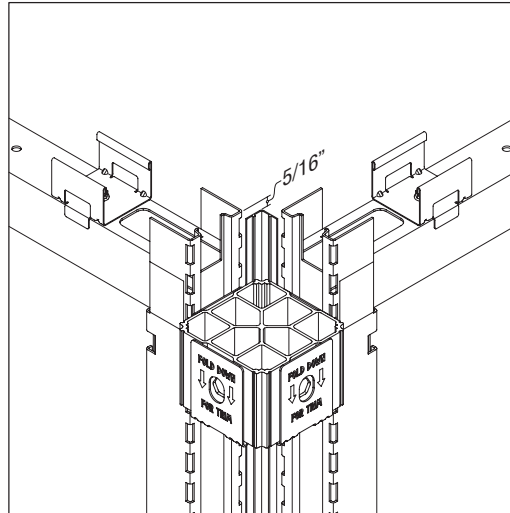

Detail B

Panel Connector Block Charts

Same Height or Lower Panel at Height-Change	
Lower Panel Height	Blocks Required
32"	2
40"	3
48"	3
56"	3
64"	3

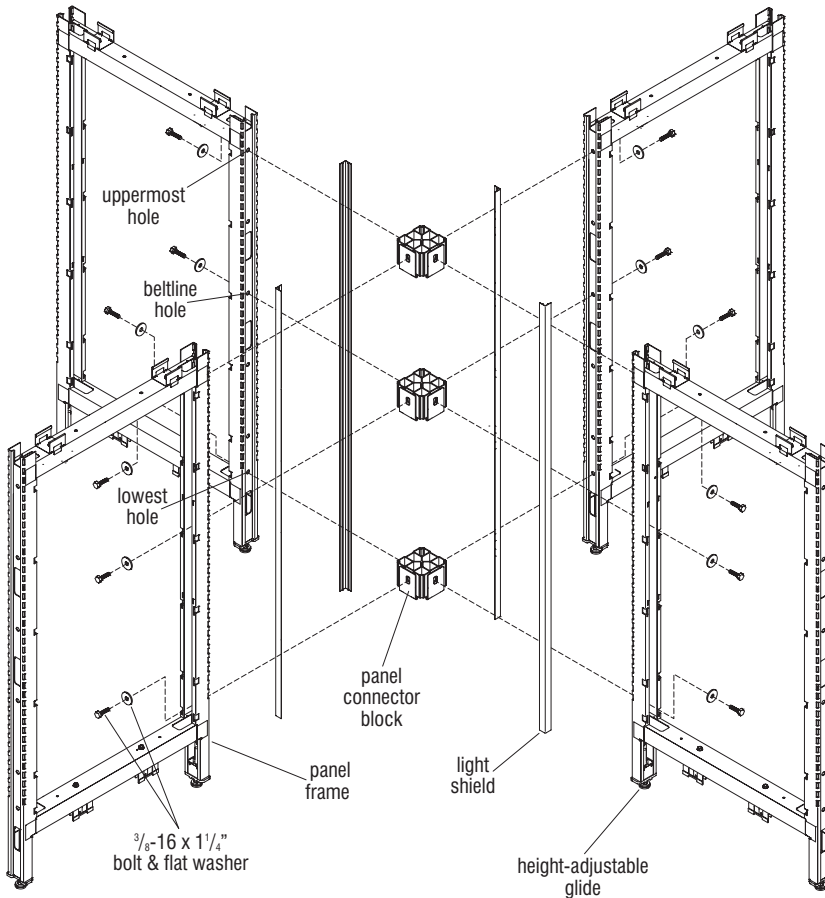
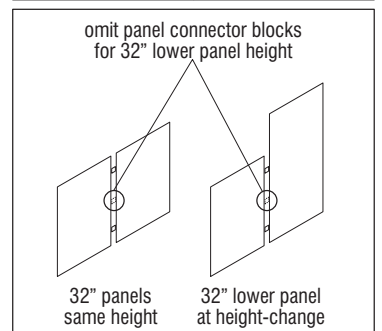
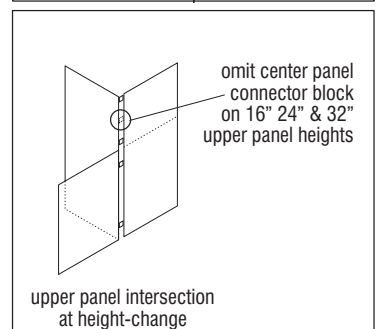

Figure 5 - Four-Panel Intersection

Upper Panel at Height-Change	
Upper Section Height	Blocks Required
8"	1
16"	2
24"	2
32"	2
40"	3
48"	3



Detail C

## ■ Unite® Panel System - Frame Installation

### Assembly Instructions



Assemble units as described herein only. To do otherwise may result in instability. All screws, nuts and bolts must be tightened securely and must be checked periodically after assembly. Failure to assemble properly, or to secure parts may result in assembly failure and personal injury.

### 120° Intersection and Frame Assembly

**Note:** Assembly of 120° intersections is similar to 90° intersections, except the design, function and installation of the light shields is different between the two. As shown on pages 4 & 5, 90° intersection light shields are made of plastic and have no tabs. The 120° intersection light shields are made of metal and have integral tabs which serve as spacers for proper panel frame spacing. Care must be taken to install 120° intersections correctly.

**Important:** It is very important to level the panel system. Know and mark all high and low spots on the floor, and make sure to twist adjustable glides out appropriate to floor conditions. Always begin assembling panels together at the highest point of an un-even floor, with the glides adjusted 1/2" from the base of the frame.

### Same-Height 120° Frame Intersections

1. Loosely attach connector blocks and appropriate length light shields to one vertical panel frame using one 3/8-16 x 1 1/4" hex head bolt and large flat washer per connector block. Slide the light shield over the mounting bolts, between the panel frame and the connector blocks (Figures 6 & 7). Attach one connector block at the lowest mounting hole in the frame, one at the highest, and the third approximately 30" from the floor, near beltway height. If the panel frame is only 32" high, use only two connector blocks, one at the top and one at the bottom (See Panel Connector Block Chart, page 5).

2. Have one person hold the panel frame (with connector blocks and light shield attached). Then attach

the next panel frame and light shield to the first panel frame using hex head bolts and flat washers. Hand-tighten hardware until all intersection connections are made (Figures 6 & 7).

**Note:** Multiple panel intersections require multiple light shields. Work around the intersection in a counter-clockwise direction attaching panel frames/light shields until all panels are loosely attached. Light shields slide in between the panel frame and connector blocks and then nest down onto mounting bolts. This requires that the intersection remains loose until all frames are attached at an intersection.

4. Tighten all hex bolts at intersections, then level the panel frames, twisting the height-adjustable glides in or out. When tightening the bolts, ensure that all intersection light shields are properly in place and fully engaged around the bolt shaft (Figures 6 & 7).

**Note:** All other 120° intersection configurations are similar in construction to 90° intersections, except for the style and installation of light shields described above. As required by your installation, reference the appropriate 90° intersection for the following configurations:

- **Height-Change Panel Intersections**
- **Pre-configured Segmented Panel Intersection with Glass or Steel Top (aluminum frame)**
- **Full-Height Stacking Panel (steel frame) Intersections**

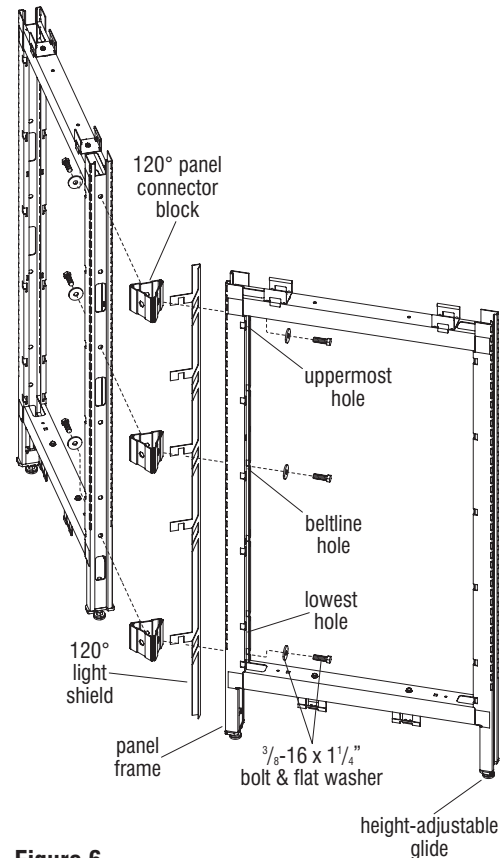

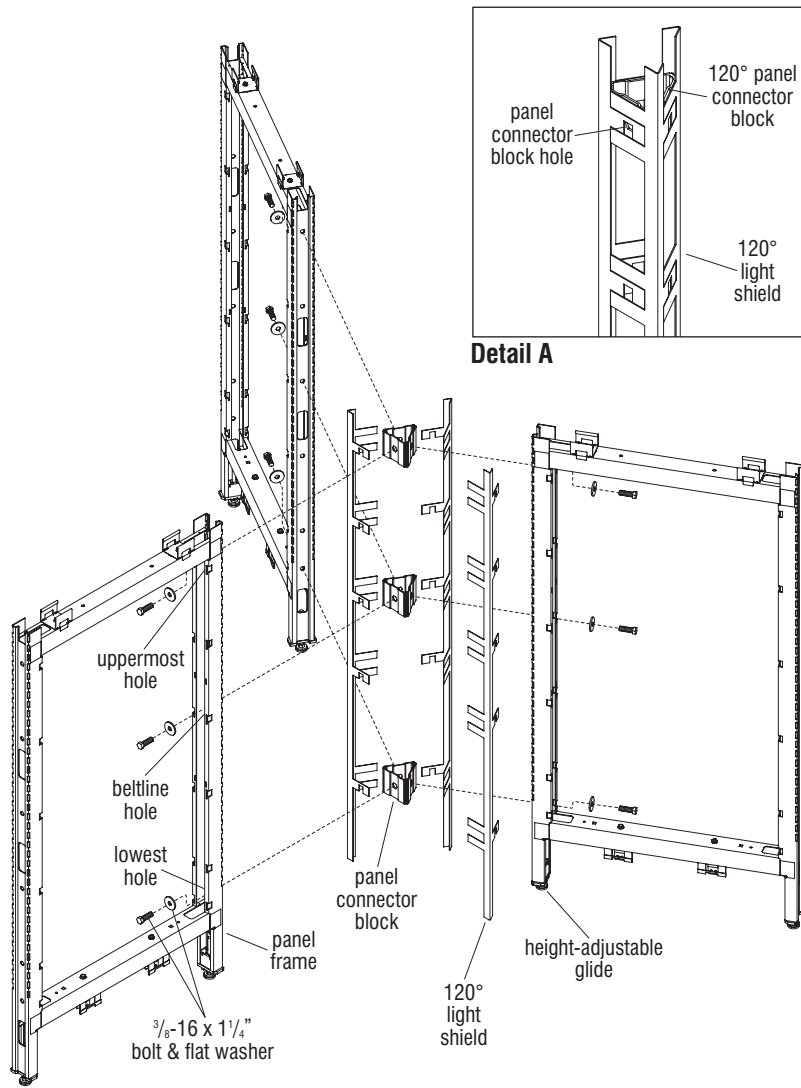

Figure 6

  
**CAUTION**

Assemble units as described herein only. To do otherwise may result in instability. All screws, nuts and bolts must be tightened securely and must be checked periodically after assembly. Failure to assemble properly, or to secure parts may result in assembly failure and personal injury.



**Figure 7**

## ■ Unite® Panel System - Frame Installation

### Assembly Instructions



Assemble units as described herein only. To do otherwise may result in instability. All screws, nuts and bolts must be tightened securely and must be checked periodically after assembly. Failure to assemble properly, or to secure parts may result in assembly failure and personal injury.

### Height-Change Panel Intersections

1. Per the space-planning layout, locate the two height-change panel frames to be joined together. Begin first with the lower-height panel as the shorter panel determines the number of connector blocks required (Figure 8).
2. Loosely attach connector blocks to the shortest vertical panel frame, as illustrated using one  $\frac{3}{8}$ -16 x  $1\frac{1}{4}$ " hex head bolt and large flat washer per connector block. Attach one connector block at the lowest mounting hole in the frame, one block at the highest, and the third connector block approximately 30" from the floor, near beltway height (Figure 8).
3. Have one person hold the shorter panel frame (with connector blocks and light shield attached) while another person attaches the taller panel frame to the mating face of the connector blocks using hex head bolts and flat washers. Hand-tighten hardware at this time (Figure 8).
4. Level each panel frame at the intersection and tighten all hex bolts.

**Note:** Light shields are available in 48, 64 & 80" nominal lengths. The above light shield lengths do not require cutting when paired with the same nominal height panel frame.

5. Begin light shield installation by first locating the nominal length plastic light shield that matches the nominal height panel frame it installs adjacent to. For nominal height 32, 40 & 56" panels,

locate a light shield that is longer than, but closest to the nominal frame height. When required (for 32, 40 & 56" panel heights), cut the longer plastic light shield to size. See Detail A - "Light Shield Table," page 5 to determine proper cut length.

6. Plastic light shields must be installed after intersections are assembled and all bolts are tightened into connector blocks. Measure and make a mark that is  $\frac{5}{16}$ " down from the top of the vertical frame post (Detail B, page 5). Using the proper length light shield, position the top of the shield at that  $\frac{5}{16}$ " mark. Snap the light shield into the corner of each connector block such that you hear a "click", ensuring that the light shield is snug at each connector block.

**Note:** The bottom of the light shield should fit flush with the bottom trim when trim is installed. The top of the light shield should fit nearly flush with the underside of an intersection top cap when it is installed later.

**Tip:** A top cap can be temporarily installed to help locate the top of the light shield. Snap the light shield in place such that the top of the shield is flush with the bottom of an installed top cap.

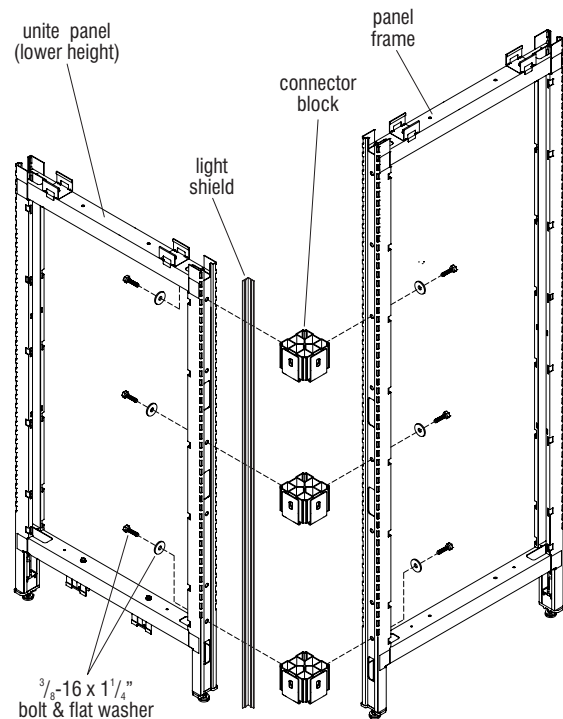



Figure 8 - Height-Change Intersection





Assemble units as described herein only. To do otherwise may result in instability. All screws, nuts and bolts must be tightened securely and must be checked periodically after assembly. Failure to assemble properly, or to secure parts may result in assembly failure and personal injury.

**Pre-configured Segmented Panel Intersection with Glass or Steel Top (aluminum frame)**

1. Install the vertical stacking posts to the top of panel frames at the intersection using  $\frac{3}{8}$ -16 x  $\frac{3}{4}$ " hex head bolts and  $\frac{3}{8}$ -16 k-lock nuts (Figure 9).

**Note:** Three connector blocks are required at every intersection.

2. Loosely attach connector blocks on one panel frame and vertical stacking post side. Each block is secured using a  $\frac{3}{8}$ -16 x  $1\frac{1}{4}$ " hex bolt and flat washer. The upper connector block attaches at the top of the vertical stacking posts, the middle connector block near the 30" belt line and the bottom connector block mounts at the lowest mounting hole of the panel frame. **Note:** If the lower panel height is near the 30" belt line height, a connector block/hardware can replace the  $\frac{3}{8}$ -16 x  $\frac{3}{4}$ " bolt and k-lock nut.

3. Attach the second panel frame and vertical stacking post assembly to the installed connector blocks of the first panel frame using  $\frac{3}{8}$ -16 x  $1\frac{1}{4}$ " hex head bolts and large flat washers (Figure 9).

4. Tighten all  $\frac{3}{8}$ -16 x  $1\frac{1}{4}$ " hex bolts securing panel frames to connector blocks at the intersection. Tighten the  $\frac{3}{8}$ -16 x  $\frac{3}{4}$ " hex head bolts to k-lock nuts, securing the vertical stacking posts at the intersection. Twist the height-adjustable glides in or out to level the panel frames (Figure 9).

**Note:** Additional instructions for pre-configured segmented panel frames are covered later in this manual (See pages 14, 15 & 16).

5. See "Note" and steps 5 & 6 on page 8 for light shield installation.

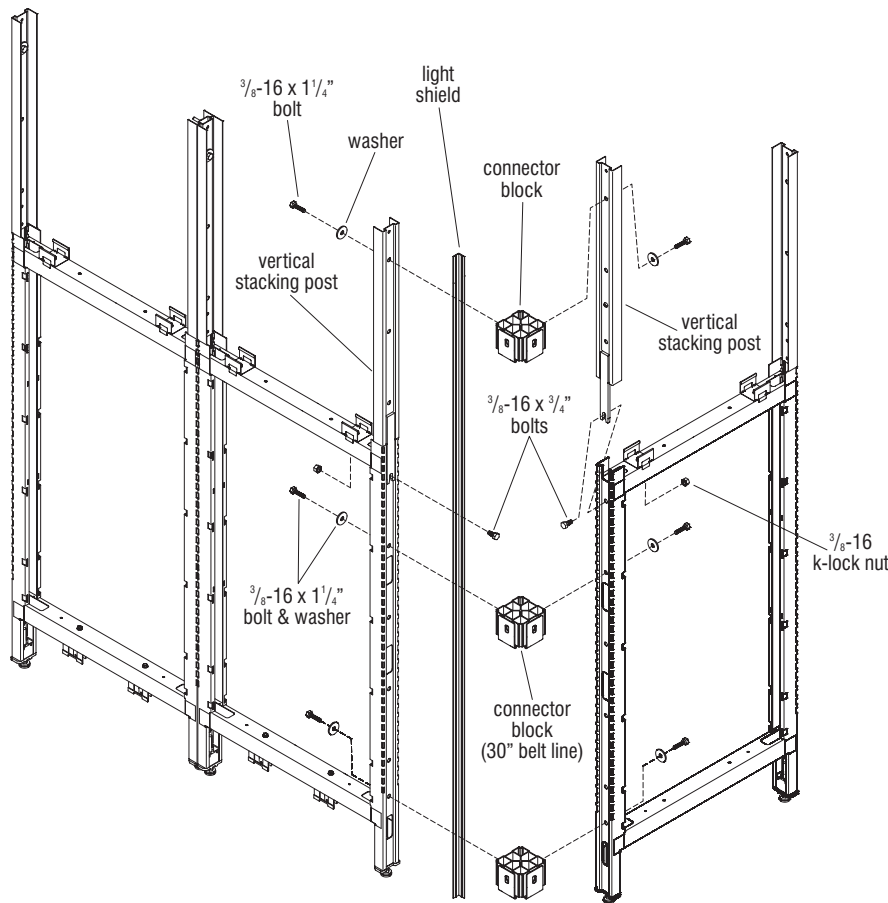

**Figure 9 - Preconfigured Segmented Panel Intersection with Glass or Steel Top (aluminum frame)**

# Unite® Panel System - Frame Installation

## Assembly Instructions



Assemble units as described herein only. To do otherwise may result in instability. All screws, nuts and bolts must be tightened securely and must be checked periodically after assembly. Failure to assemble properly, or to secure parts may result in assembly failure and personal injury.

### Full-Height Stacking Panel (steel frame) Intersections

**Note:** Full-height stacking panel intersections are specified/ordered at time of original space planning and come with full-height light shield, full-height intersection trim and three connector blocks as illustrated (Figure 10). Stacking panel frames receive tiles, similar to standard panels.

**IMPORTANT:** Refer to page 3 for usage overview on connector block with spacer plate (Detail A).

**Important:** When “add-on option” stacking panel frames are ordered after original space planning/installation to be installed to existing panel intersections, the light shield and trim will ship in two pieces to install in two pieces (Page 11, Figure 11).

**Note:** If full-height Intersection trim and full-height light shield (optional) are desired after original space plan installation; instead of two-piece assembly, the intersection must be completely disassembled to install the full-height intersection trim (Figure 10). The steps below and Figure 10 above illustrate the full-height stacking intersection connection, as ordered at time of space planning.

1. Prior to proceeding with “Full-Height Stacking Panel (steel frame) Intersections”, see “Stacking Panel (steel frame) In-line Installation” (page 17, Figure 17) and assemble stacking panel frames over lower panel frames as instructed.

**Note:** Three connector blocks are required at every full-height stacking panel frame intersection.

2. Loosely attach connector blocks on one panel frame and stacking panel post side. Each block is

connected using a  $\frac{3}{8}$ -16 x  $1\frac{1}{4}$ ” hex bolt and flat washer. The upper connector block attaches at the top of the vertical stacking posts, the middle connector block near the 30” belt line and the bottom connector block mounts at the lowest mounting hole of the panel frame (Figure 10). **Note:** If the lower panel height is near the 30” belt line height, a connector block/hardware can replace the upper  $\frac{3}{8}$ -16 x  $\frac{3}{4}$ ” bolt and k-lock nut.

3. Next, attach the second panel with full-height stacking panel assembly to the installed connector blocks of the first

assembly using  $\frac{3}{8}$ -16 x  $1\frac{1}{4}$ ” hex head bolts and large flat washers (Figure 10).

4. Tighten all hex bolts securing panel frames to connector blocks in the intersection. Tighten the  $\frac{3}{8}$ -16 x  $\frac{3}{4}$ ” hex head bolts and  $\frac{3}{8}$ -16 k-lock nuts, securing the “forks” of the full-height stacking panels. Twist the height-adjustable glides in or out to level the panels (Figure 10).
5. See “Note” and steps 5 & 6 on page 8 for light shield installation.

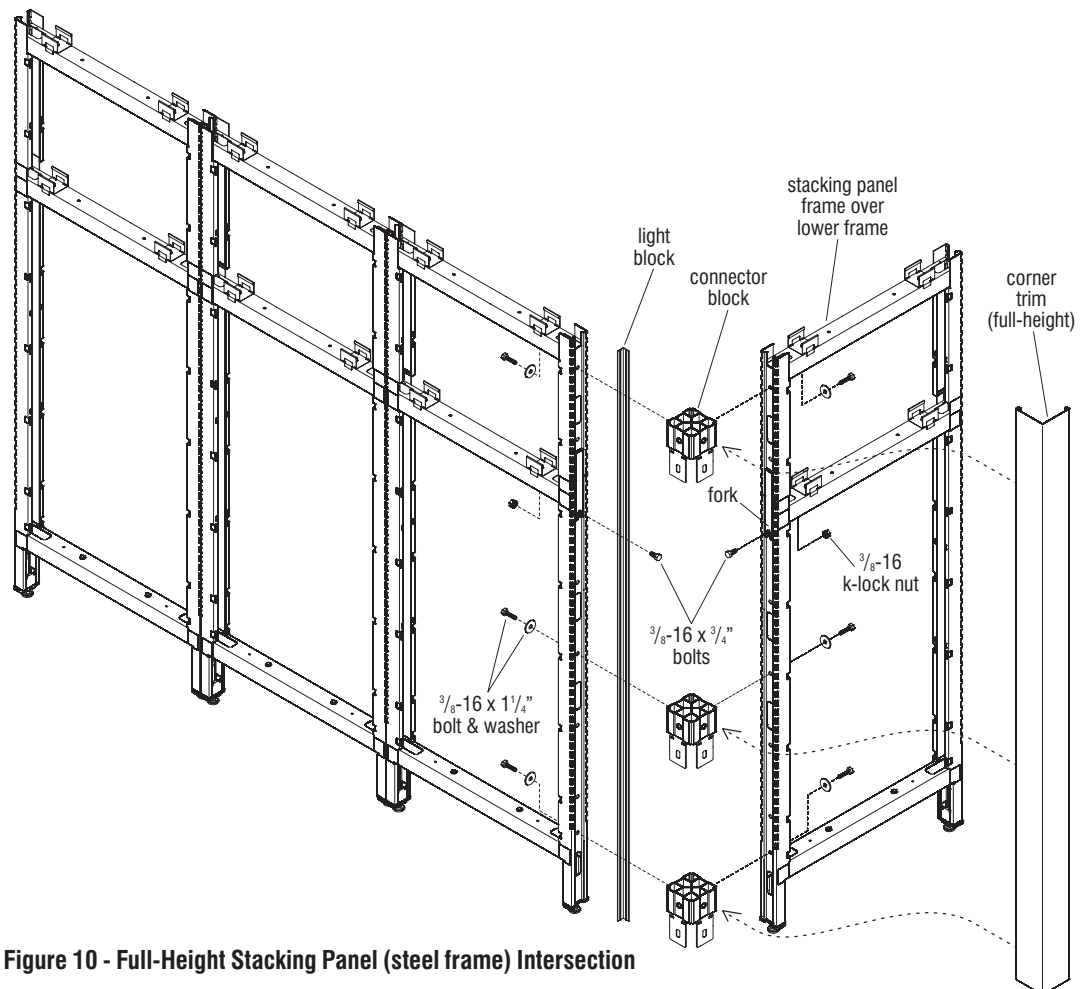

**Figure 10 - Full-Height Stacking Panel (steel frame) Intersection**



**CAUTION** Assemble units as described herein only. To do otherwise may result in instability. All screws, nuts and bolts must be tightened securely and must be checked periodically after assembly. Failure to assemble properly, or to secure parts may result in assembly failure and personal injury.

**Stacking Panel (steel frame) - At Intersections**

**Note:** Stacking panels are an “add-on” panel option, which are installed to existing panel configurations. Stacking panel frames at intersections receive stacking intersection trim, which is spliced to existing lower intersection trim so is not continuous in length. Stacking panel frames receive tiles, similar to that of standard panels. The installation of in-line stacking panel frames is covered later in this manual (page 17, Figure 17). The following steps and Figure 11 illustrate the intersection connections.

**Important:** Stacking panel frames have “forks” that drop into the tops of standard panel frames (after the top caps are removed) and do not require a fastener (Figure 11).

**IMPORTANT:** Refer to page 3 for usage overview on connector block with spacer plate (Detail A).

1. Press or carefully tap the stacking panel frames down into position at the top of the panel frames using a rubber mallet.

2. When assembling stacking panel frames at intersections, loosely attach two connector blocks to the stacking panel. Use a  $\frac{3}{8}$ -16 x  $1\frac{1}{4}$  hex head bolt and large flat washer to attach one connector block to the lowest mounting hole in the stacking frame and one to the highest mounting location (Figure 11).

3. Loosely attach the second stacking panel frame to the two connector blocks on the first stacking panel frame using  $\frac{3}{8}$ -16 x  $1\frac{1}{4}$  hex head bolts and large flat washers.

4. Tighten all  $\frac{3}{8}$ -16 x  $1\frac{1}{4}$  hex bolts securing panel frames to connector blocks at the intersection (Figure 11).

4a. In-line Stacking Panel Frames: Attach each stacking panel frame to the one next to it at the top, similar to standard panel frames by using a  $\frac{3}{8}$ -16 x  $1\frac{1}{4}$  bolt, two washers and a  $\frac{3}{8}$ -16 k-lock nut (Figures 11 & 15).

4b. End-of-Run Stacking Panel Frames: At end of a run conditions, the stacking panel “fork” must be secured to the end panel frame using a  $\frac{3}{8}$ -16 x  $\frac{3}{4}$ ” bolt and  $\frac{3}{8}$ -16 k-lock nut (Figures 11 & 14).

**Important:** If an “end-of-run trim clip” was previously installed to the top of the lower panel, it must be removed and re-installed down one hole location so the fork of the stacking panel can be secured. To gain access, one tile must be removed from the end panel. (See “End-of-Run Trim Clip Installation” on page 18, Figure 19).

**Note:** Corner trim is generally installed later, but is illustrated above and described briefly below, since this is an add-on component installation.

5. See “Note” and steps 5 & 6 on page 8 for light shield installation.

6. Original, lower vertical corner intersection trim should be hung back onto the connector blocks, then a vertical 90° splice clip must be slid into the top of the intersection trim. Upper intersection corner trim then hangs onto the stacking panel frame connector blocks and slides onto the top of the installed vertical 90° splice clip to keep it aligned (Figure 11).

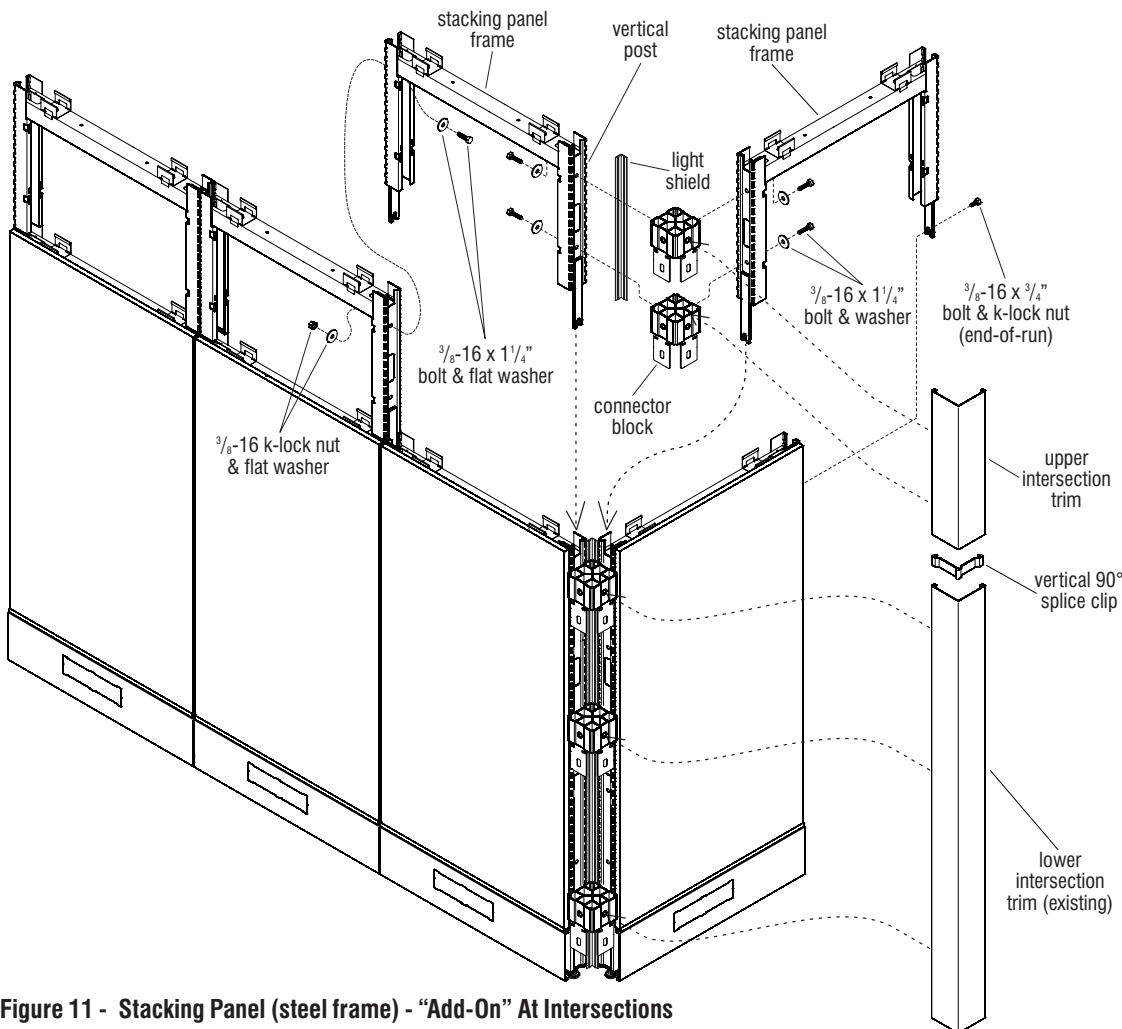

**Figure 11 - Stacking Panel (steel frame) - “Add-On” At Intersections**

## ■ Unite® Panel System - Frame Installation

Assembly Instructions



Assemble units as described herein only. To do otherwise may result in instability. All screws, nuts and bolts must be tightened securely and must be checked periodically after assembly. Failure to assemble properly, or to secure parts may result in assembly failure and personal injury.

### In-Line Panel Frame Assembly

**Note:** Always begin frame assembly at the highest point of an un-even floor, with the glides adjusted  $\frac{1}{2}$ " from fully seated to account for varying floor conditions.

1. Stand frames next to each other and align mounting holes of both vertical posts. Place a large flat washer on each of three  $\frac{3}{8}$ -16 x  $1\frac{1}{4}$ " hex head bolts, and insert the bolt with washer through both frames to be connected. **Note:** Install one bolt through the lowest mounting hole of the pair of frames, one bolt through the highest mounting hole of the shortest frame (if one frame is taller than the other) and one bolt through the mounting hole roughly at 30" from the floor, near beltway height. At the thread end of each bolt, add a large flat washer and loosely install a  $\frac{3}{8}$ -16 k-lock nut (Figure 12).
2. Tighten all hardware, then level the panels, twisting the height-adjustable glides in or out (Figure 12).

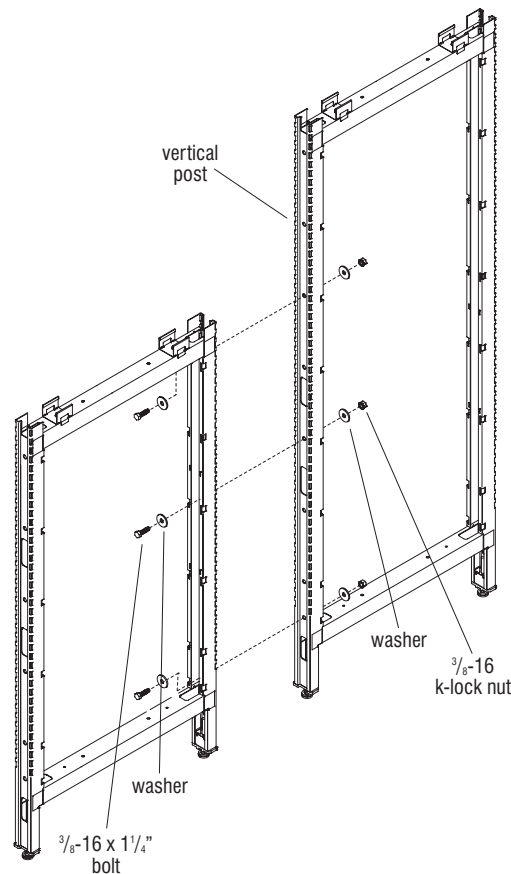

Figure 12 - In-Line Panel Frame Assembly



Assemble units as described herein only. To do otherwise may result in instability. All screws, nuts and bolts must be tightened securely and must be checked periodically after assembly. Failure to assemble properly, or to secure parts may result in assembly failure and personal injury.

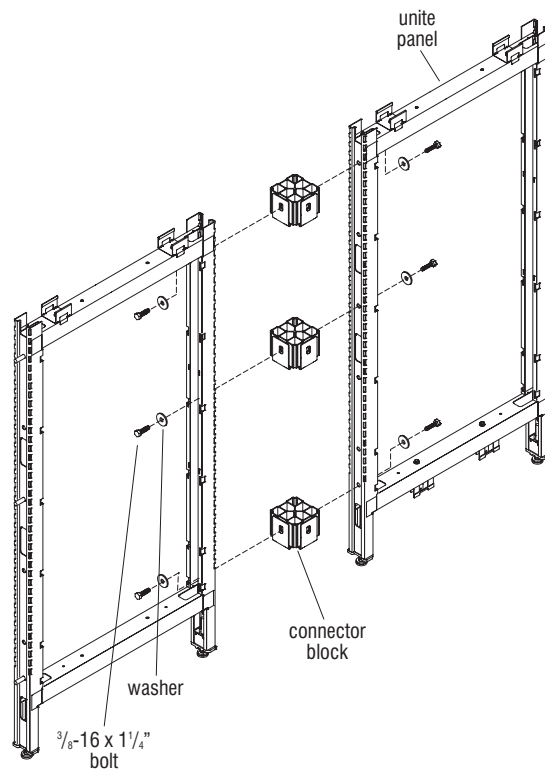

Figure 13 - In-Line 180° Intersection Connection

### In-Line 180° Intersection Connection

**Note:** The space-planning layout may specify an in-line panel frame connection. In this intersection condition, light shields are not required.

1. Loosely attach connector blocks to one vertical panel frame (to the shortest panel frame first, if panels are of different height) using one  $\frac{3}{8}$ -16 x  $\frac{1}{4}$ " hex head bolt and large flat washer per connector block. Attach one connector block to the lowest mounting hole in the frame, one block at the highest, and the third connector block approximately 30" from the floor, near beltway height. If the panel frame is only 32" high, use only two connector blocks, one at the top and one at the bottom (See Panel Connector Block Charts, page 5).

**Note:** Each frame at an intersection must have a connector block in the top-most bolt hole unless there is no adjacent connection due to a height-change condition.

3. Align the second panel frame to the panel frame with installed connector blocks, and attach using  $\frac{3}{8}$ -16 x  $\frac{1}{4}$ " hex head bolt and large flat washer through the panel frame and into the panel connector blocks of the first frame. Hand-tighten hardware at this time (Figure 13).
4. Tighten all hex bolts attaching the frames, then level the frames, twisting the height-adjustable glides in or out (Figure 13).

# Unite® Panel System - Frame Installation

## Assembly Instructions



Assemble units as described herein only. To do otherwise may result in instability. All screws, nuts and bolts must be tightened securely and must be checked periodically after assembly. Failure to assemble properly, or to secure parts may result in assembly failure and personal injury.

### Preconfigured Segmented Panels with Glass or Steel Top (aluminum frame) - In-Line Assembly

**Note:** Preconfigured segmented panels are constructed to previously assembled and leveled panel frames. Installation of "Preconfigured Segmented Panel Intersection with Glass or Steel Top" are covered on page 9, Figure 9. The steps below and Figure 14 illustrate in-line assembly.

1. At a joined pair of panel frames, position two vertical stacking posts back-to-back as illustrated, and press them into the cavity at the top where two panel frames meet. Posts may be tapped in place one at a time using a rubber mallet. If necessary, loosen the bolt securing the upper vertical member of the panel frames, tap the vertical stacking posts in, then re-tighten the bolt (Figure 14).
2. Secure the back-to-back vertical stacking posts together using a  $\frac{3}{8}$ -16 x  $1\frac{1}{4}$ " hex head bolt, two washers and a  $\frac{3}{8}$ -16 k-lock nut (Figure 14).
3. At end-of-run conditions, loosely insert a shorter  $\frac{3}{8}$ -16 x  $\frac{3}{4}$ " hex head bolt to the top mounting hole of the end panel frame, then twist on a  $\frac{3}{8}$ -16 k-lock nut.  
**Note:** The nut must be positioned inside the panel frame and flat washers are not required. Next, place a vertical stacking post at end of the panel frame as illustrated, with the notch of the stacking post fork over the hex nut. Tighten the hex bolt and k-lock nut to secure (Figure 14).

4. Before installing a segmented panel with glass or steel top into the vertical stacking posts on panels, all internal components, as well as exterior tiles must be installed to lower panel frames. Continue on with instructions, beginning at page 38 or 39, Figure 1 through 2, depending on the type of tile being installed, then come back to page 15 instructions, Figure 15.

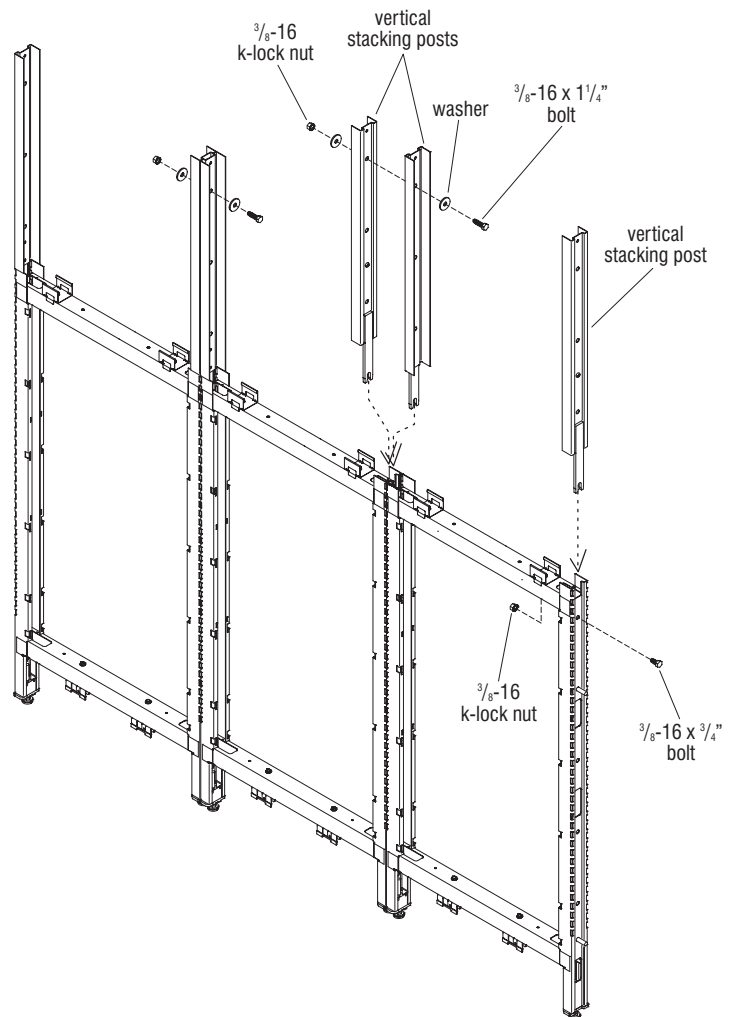
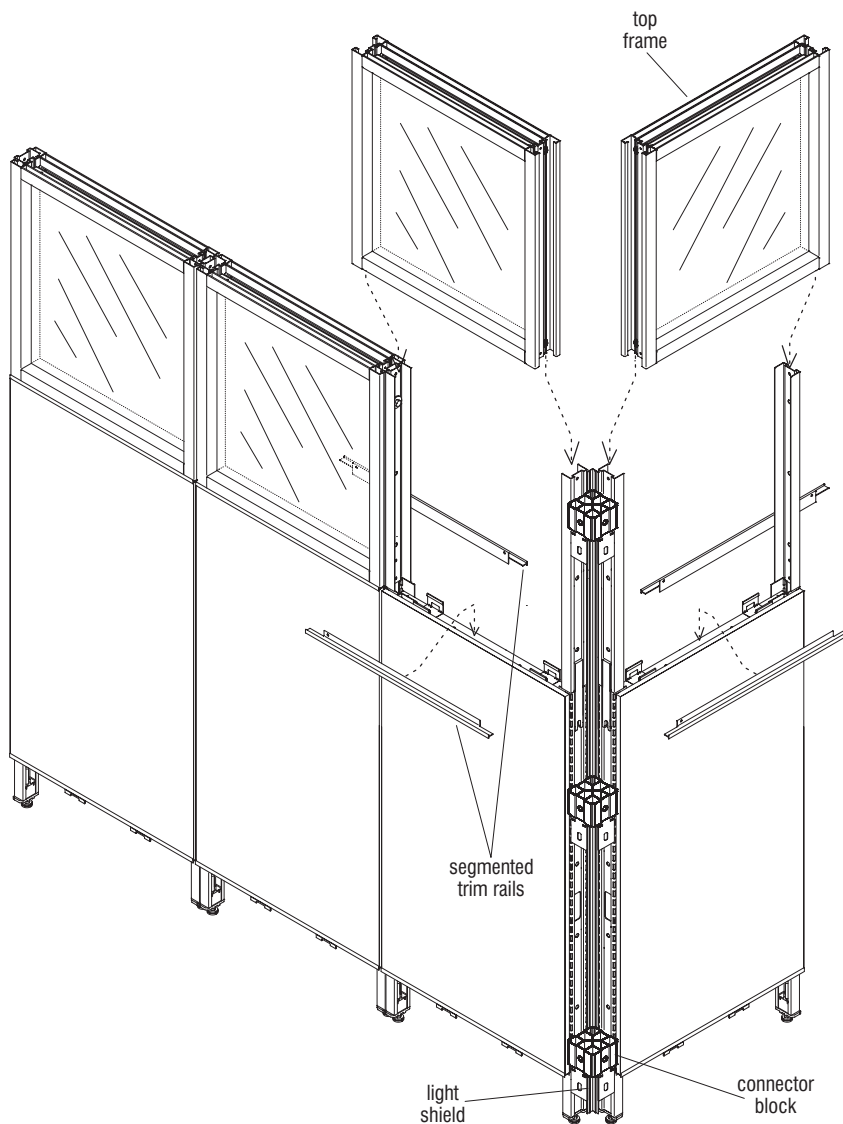

Figure 14 - Preconfigured Segmented Panel with Glass or Steel Top (aluminum frame) - In-Line Vertical Stacking Posts Assembly



Assemble units as described herein only. To do otherwise may result in instability. All screws, nuts and bolts must be tightened securely and must be checked periodically after assembly. Failure to assemble properly, or to secure parts may result in assembly failure and personal injury.



**Figure 15 - Preconfigured Segmented Panel with Glass or Steel Top (aluminum frame)  
- Top Frame Installation**

**Preconfigured Segmented Panels with Glass or Steel Tops (aluminum frame)**

**Note:** Top frames must be installed to vertical stacking posts after all panel components and exterior tiles are installed to lower panel frames.

**Caution:** Placement of a 1" block of foam on top of the lower panel frame is recommended to avoid pinching fingers. Position foam blocks prior to sliding top frames down into place. Remove the foam block after the top frame has been lowered into position.

**Note:** Top frames have a top-side and a bottom. The top horizontal frame section has parallel ribs running along the length of the frame for snapping on clips for top caps.

5. Carefully slide the top frame down between the vertical stacking posts (Figure 15).
6. Segmented trim rails must fit between the lower panel tile and the top frame bottom. Lift the top frame up a few inches then install two trim rails; one on each side of the panel. Ensure the large flange is oriented toward the center of the panel. Carefully lower the top frame on the foam blocks. Remove the foam blocks to capture the trim rails in place (Figure 15).
7. Ensure each top frame is installed securely and even onto the lower panels. Alignment along the top of adjacent top frames must be even for trim to fit properly (Figure 15).

## ■ Unite® Panel System - Frame Installation

Assembly Instructions



Assemble units as described herein only. To do otherwise may result in instability. All screws, nuts and bolts must be tightened securely and must be checked periodically after assembly. Failure to assemble properly, or to secure parts may result in assembly failure and personal injury.

### Preconfigured Segmented Panel with Glass or Steel Top (aluminum frame) - Installation of Glass or Steel Top - (cont.)

8. Segmented panel frames at end of run panels, or at in-line changes of height, require a metal spacer and screw to secure the end segmented panel to the vertical stacking posts. Position and hold one metal spacer between the top vertical member of the vertical stacking posts, and the top frame. Align with the mounting holes of both, then insert and tighten one #12 x 1" sheet metal machine screw (Figure 16).

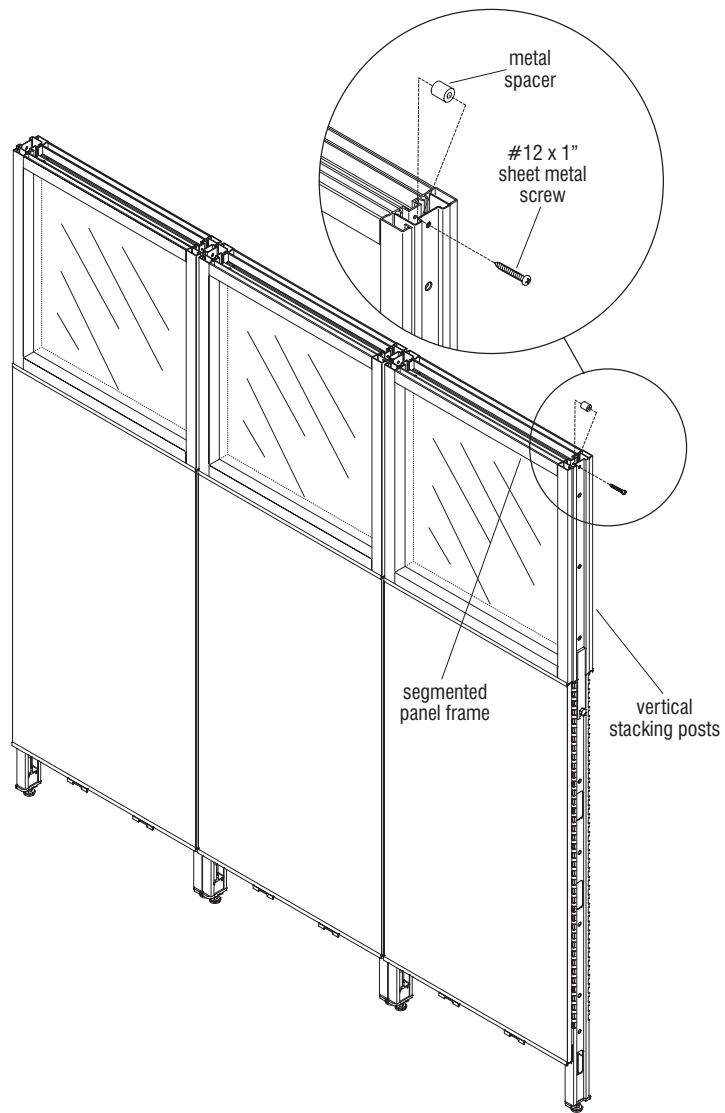
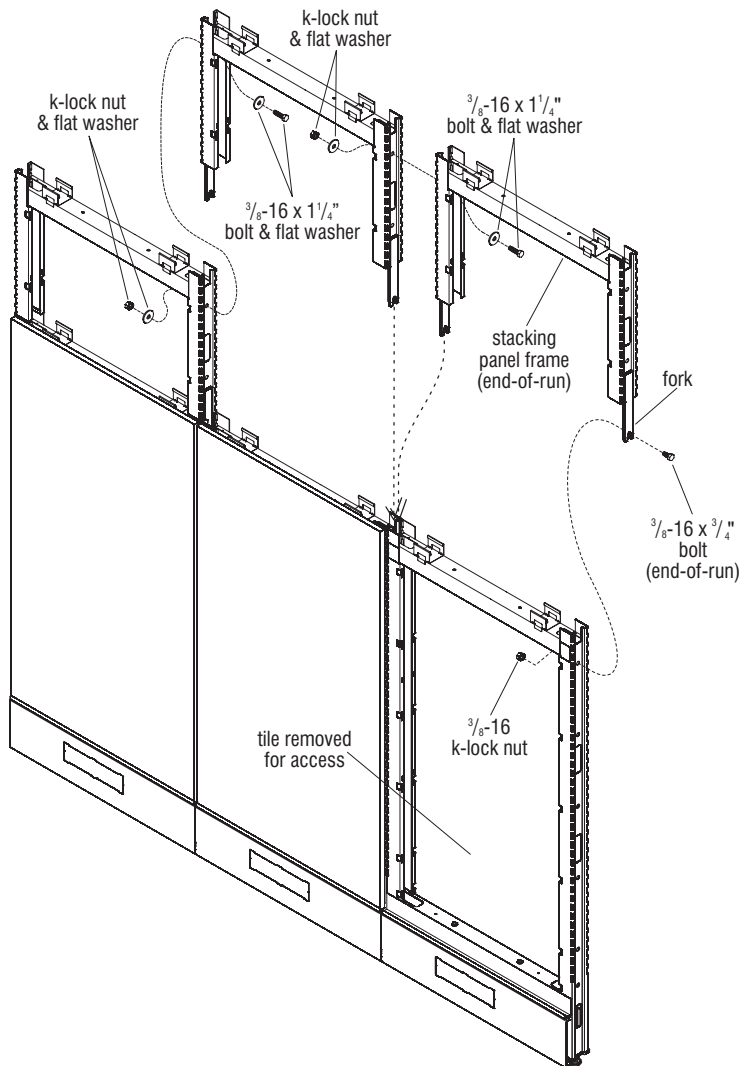

**Figure 16 - Preconfigured Segmented Panel with Glass or Steel Top (aluminum frame) - Installation of Glass or Steel Top**





Assemble units as described herein only. To do otherwise may result in instability. All screws, nuts and bolts must be tightened securely and must be checked periodically after assembly. Failure to assemble properly, or to secure parts may result in assembly failure and personal injury.



**Figure 17 - Stacking Panel (steel frame) Inline Installation**

**Stacking Panel (steel frame)  
 In-Line Installation**

**Note:** Stacking panel frames are an “add-on” panel option which are installed to existing panel configurations. Stacking panel frames receive tiles, similar to those of standard panels. The installation of “Stacking Panel (steel frame) - At Intersections” was covered earlier in this manual (page 11, Figure 11). The steps below and Figure 14 illustrate in-line and end-of-run installation.

**Important:** Stacking panel frames have “forks” that slide into the tops of standard panel frames (after the top caps are removed) and snug the stacking panel frames in place (Figure 17).

1. As illustrated, press or carefully tap the stacking panel frames down into position using a rubber mallet. In-line stacking panel frames attach to each other at the top inside of each frame using a  $\frac{3}{8}$ -16 x  $1\frac{1}{4}$ ” bolt, two washers and a  $\frac{3}{8}$ -16 k-lock nut (Figure 17).
2. At the end of a run of stacking panel frames, the “fork” must be secured to the end panel frame using a  $\frac{3}{8}$ -16 x  $\frac{3}{4}$ ” bolt and k-lock nut. To install this, one tile must be removed from the end panel to gain access (Figure 17).

**Important:** If an “end-of-run trim clip” was previously installed to the top of the lower panel, it must be removed and re-installed down one hole location so the fork of the stacking panel can be secured. (See “End-of-Run Trim Clip Installation” on page 18, Figure 19).

# Unite® Panel System - Frame Installation

## Assembly Instructions



Assemble units as described herein only. To do otherwise may result in instability. All screws, nuts and bolts must be tightened securely and must be checked periodically after assembly. Failure to assemble properly, or to secure parts may result in assembly failure and personal injury.

### End-of-Run Trim Clip Installation

**Note:** End-of-run trim clips are installed to end-of-run panel frames to hold vertical trim in place. End-of-run clips must be installed prior to installing tiles.

1. End-of run trim clips attach to the panel using a  $\frac{3}{8}$ -16 x  $\frac{3}{4}$ " hex head bolt and  $\frac{3}{8}$ -16 k-lock nut. All end-of-run panels, except the shortest 32" high panel will require three clips installed (see End-of-Run Trim Clip Charts below). Attach one end-of-run clip at the lowest mounting hole in the frame, one clip at the highest, and the third end-of-run clip approximately 30" from the floor, near beltway height (Figure 18).

2. For "stacking panel frames" (shown Figure 19), or "preconfigured segmented panels with glass or steel tops" (not shown, but similar), end-of-run trim clips install to the upper panel (see "Upper Panel Frame at Height Change" chart below for quantity). For the "end-of-run lower panel frame" (Figure 19), the uppermost end-of-run clip must be re-installed one hole location below the top mounting hole. This is so the "fork" of the stacking panel frame can install to the end of the lower panel frame. Loosely insert a  $\frac{3}{8}$ -16 x  $\frac{3}{4}$ " hex head bolt to the top mounting hole of the lower end panel frame, then twist on a  $\frac{3}{8}$ -16 k-lock nut. The nut must be positioned inside the panel frame and flat washers are not required.

3. Slide/tap the stacking panel frame down at end of the panel frame as illustrated, with the notch of the fork behind the  $\frac{3}{8}$ -16 x  $\frac{3}{4}$ " hex bolt. Tighten the hex bolt and k-lock nut to secure (Figure 19).

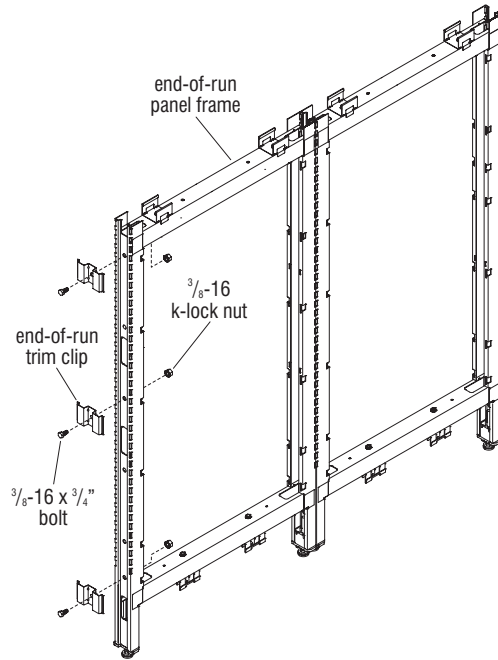

Figure 18 - End-of-Run Trim Clip Installation

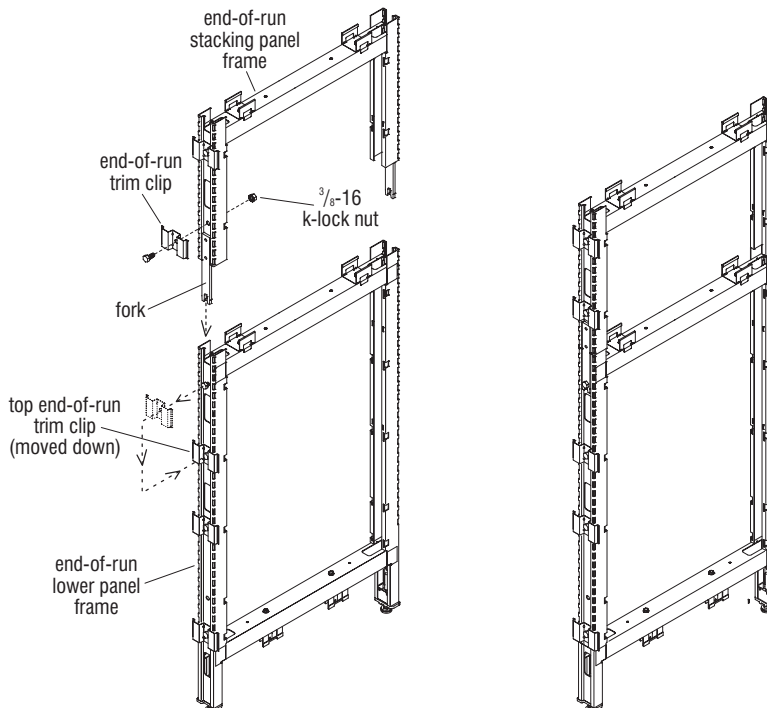



Figure 19 - End-of-Run Clips - with Stacking Panel Frames or Preconfigured Segmented Panels with Glass or Steel Tops

### End-of-Run Trim Clip Charts

Same Height - or Lower End Panel at Height-Change	
Panel Height	Trim Clips Required
32"	2
40"	3
48"	3
56"	3
64"	3

Upper Panel Frame at Height Change	
Upper Section Height	Trim Clips Required
8"	1
16"	2
24"	2
32"	2
40"	3
48"	3



Assemble units as described herein only. To do otherwise may result in instability. All screws, nuts and bolts must be tightened securely and must be checked periodically after assembly. Failure to assemble properly, or to secure parts may result in assembly failure and personal injury.

CAUTION

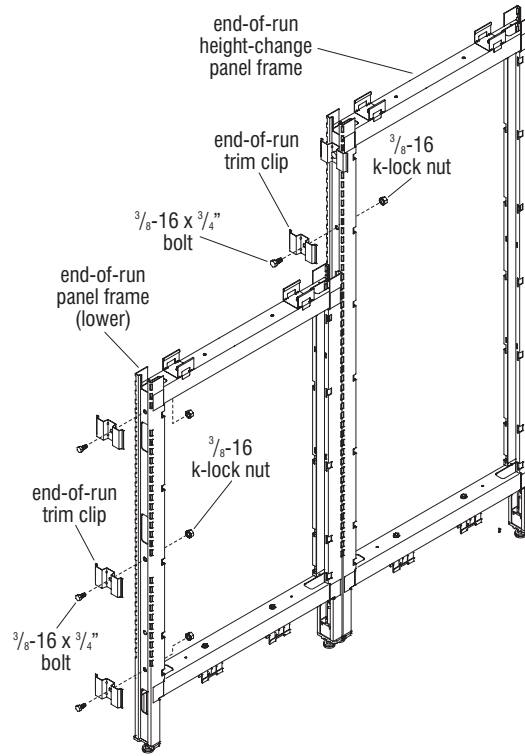

**Figure 20 - End-of-Run Trim Clips - On Height-Change Panel Frames**

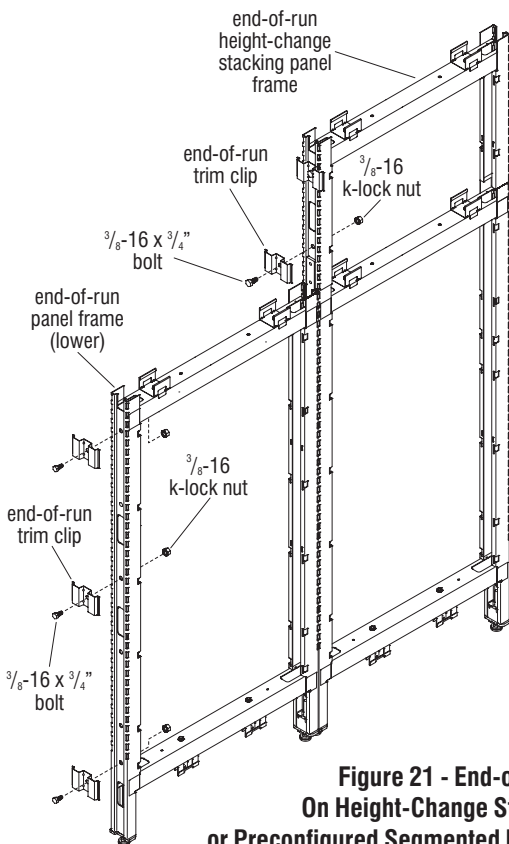

**Figure 21 - End-of-Run Trim Clips - On Height-Change Stacking Panel Frames or Preconfigured Segmented Panels with Glass or Steel Tops**

**End-of-Run Trim Clip at Height-Change Installation**

**Note:** End-of-run trim clips are installed to end-of-run panels and height-change panel ends to hold vertical trim in place. End-of-run trim clips must be installed prior to installing tiles.

1. End-of run trim clips attach to the "lower" end panel frame using a 3/8-16 x 3/4" hex head bolt and 3/8-16 k-lock nut. All end-of-run panels, except the shortest 32" high panel require three clips installed (see "Same Height- or Lower End Panel at Height-Change" trim clip chart, page 18). Attach one end-of-run clip at the lowest mounting hole in the frame, one clip at the highest, and the third end-of-run clip approximately 30" from the floor, near beltway height (Figures 20 & 21).
2. For "end-of-run height-change panel frames" (Figure 20), or "end-of-run height-change stacking panel frames" (Figure 21), and pre-configured segmented stacking panel frames with glass or steel tops (not shown, but similar) end-of-run trim clips install to the upper height-change panel to hold on end-of-run trim. See "Height-Change Upper Panel Frame" chart to determine the number of trim clips required (Figures 20 & 21).
3. End-of run trim clips attach to the "height-change" end panel using a 3/8-16 x 3/4" hex head bolt and 3/8-16 k-lock nut (Figures 20 & 21).

# ■ Unite® Panel System - Frame To Genius Wall

## Assembly Instructions



Assemble units as described herein only. To do otherwise may result in instability. All screws, nuts and bolts must be tightened securely and must be checked periodically after assembly. Failure to assemble properly, or to secure parts may result in assembly failure and personal injury.

### Perpendicular Panel Start - Unite to Genius Wall Installation

**Note:** Perpendicular connections of the Unite Panel System to Genius Wall utilize a "Perpendicular Start Track", which replaces a section of Genius Wall connecting trim and is installed at the union of two Genius Wall panels.

1. Locate the "perpendicular start track" and unscrew the pre-installed self-drilling screws from the track. Take the Unite panel frame which will join to Genius Wall, and loosely attach the perpendicular start track to the vertical end of the Unite panel frame using the studs of the track, and k-lock nut (Figure 22).
2. Position the Unite panel frame with loosely attached perpendicular start track up to the Genius panel joints location where it will install, then mark onto the previously installed Genius Wall connecting trim. Mark the height of the start track to the connecting trim and Genius wall, then remove the Unite panel and start track. Remove the Genius Wall connecting trim, cut and remove the lower section of the connecting trim, then replace the connecting trim to above where the Unite Panel will join the Genius panel joints (Figure 22).
3. Uninstall the perpendicular start track from the Unite Panel frame. Press the start track into the Genius joint at the location marked on the panel joints, just below the Genius Wall connecting trim. Re-insert the two self-drilling screws (removed in step 1) to the top and bottom screw locations, then tighten the screws through the start track and into the joint between the panels as illustrated (Figure 22).

**Note:** If the Unite panel being connected is an "Elevated Base" panel, then a small section of Genius Wall connecting trim can be cut to size from the discarded piece, and mounted to the location below the perpendicular start track.

4. Move the Unite Panel into position, onto the studs of the perpendicular start track, then secure using k-lock nuts and flat washers as illustrated (Figure 22).

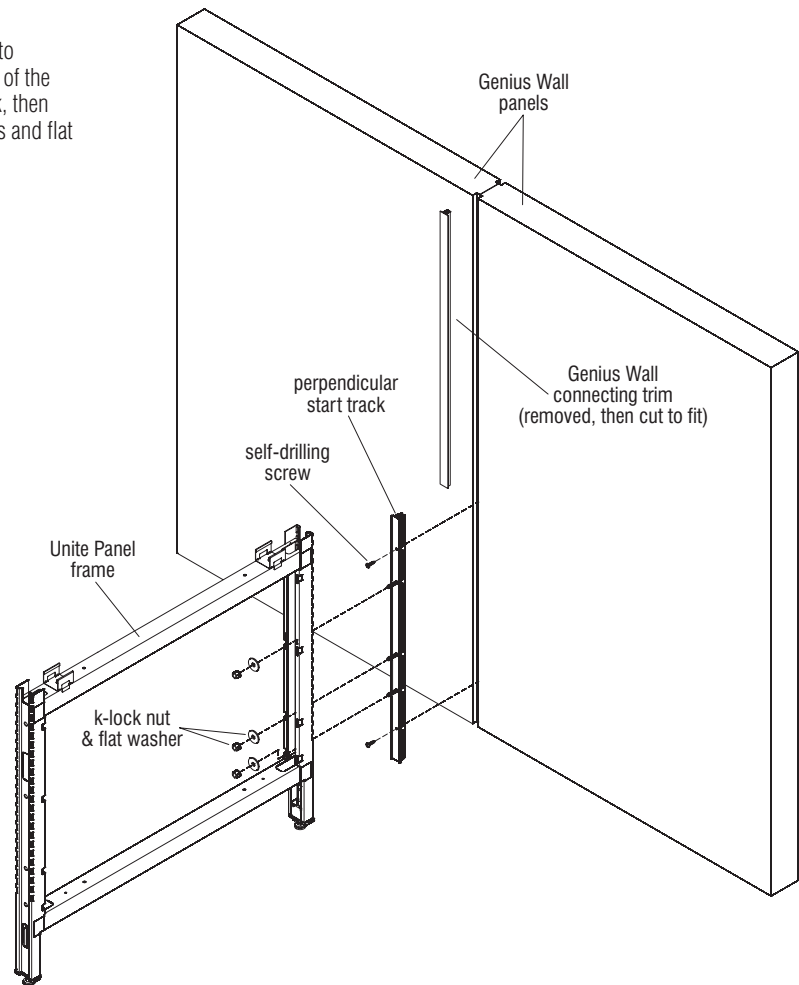

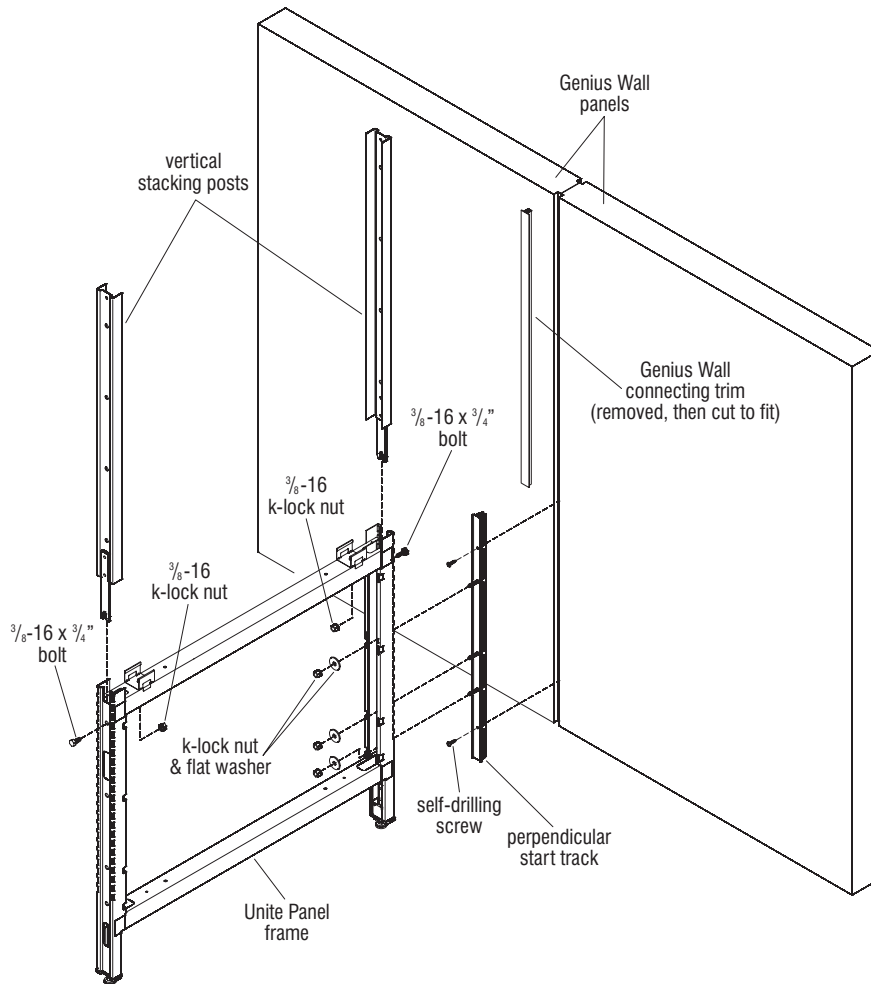

Figure 22 - Unite to Genius Wall Installation Start



**CAUTION** Assemble units as described herein only. To do otherwise may result in instability. All screws, nuts and bolts must be tightened securely and must be checked periodically after assembly. Failure to assemble properly, or to secure parts may result in assembly failure and personal injury.



**Figure 23 - Unite Preconfigured Segmented Panel to Genius Wall Installation Start**

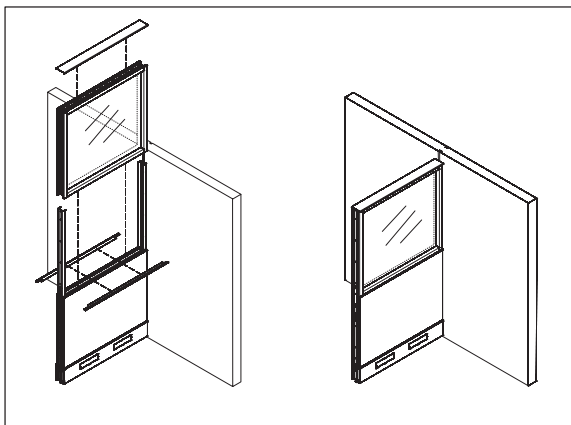

**Detail A**

**Perpendicular Panel Start - Unite Preconfigured Segmented Panel to Genius Wall Installation**

**Note:** Perpendicular connections of the Unite Panel System to Genius Wall utilize a “Perpendicular Start Track”, which replaces a section of Genius Wall connecting trim and is installed at the union of two Genius Wall panels.

**Important:** The vertical stacking post at the location where the Unite Panel meets the Genius Wall panel, must be installed to the Unite Panel frame before Unite frame attaches to Genius Wall.

1. Using a  $\frac{3}{8}$ -16 x  $\frac{3}{4}$ ” bolt and k-lock nut install a vertical stacking post to the Unite frame, at the side of the frame which will install to the Genius Wall joint (Figure 23).
2. Follow instructions, “Perpendicular Panel Start - Unite to Genius Wall Installation”, steps 1 through 4 (Figure 22) on previous page to install Unite panel with vertical stacking post onto Genius Wall (Figure 22).
3. Install all remaining vertical stacking posts and top frames to Unite frames per steps 1 through 8 on pages 14 through 16 (Figures 14, 15 & 16). See Detail A below.

**Note:** The perpendicular start should fit flush to the Genius Wall panels when properly installed.

## ■ Unite® Panel System - Frame To Genius Wall

Assembly Instructions



Assemble units as described herein only. To do otherwise may result in instability. All screws, nuts and bolts must be tightened securely and must be checked periodically after assembly. Failure to assemble properly, or to secure parts may result in assembly failure and personal injury.

### Universal Panel Start - Unite to Genius Wall Installation

**Note:** Universal connections of the Unite Panel System to Genius Wall utilize self-drilling screws and shoulder washers. Corner installation is shown, although installation of Unite can be to corner, in-line or 3-way conditions of a Genius Wall section.

1. Position Unite Panel frame up to Genius Wall at the desired installation location. If installing to a corner (Figure 24), temporarily install a top cap to the top of the Unite Panel frame. Use the width of the installed top cap to align the panel location for flush mounting to corner locations (Figure 24).
2. Properly plumb and align the Unite panel frame to the mounting location, then using six  $\frac{1}{4}$ -14 x  $1\frac{1}{4}$ " hex head self-drilling screws & shoulder washers, run the self-drilling screws through the Unite panel mounting locations, and into the aluminum trim of the Genius Wall (Figure 24).

**Important:** Using a power-driver, twist self-drilling screws in to a snug-fit only. Take care to not over-tighten the mounting screws.

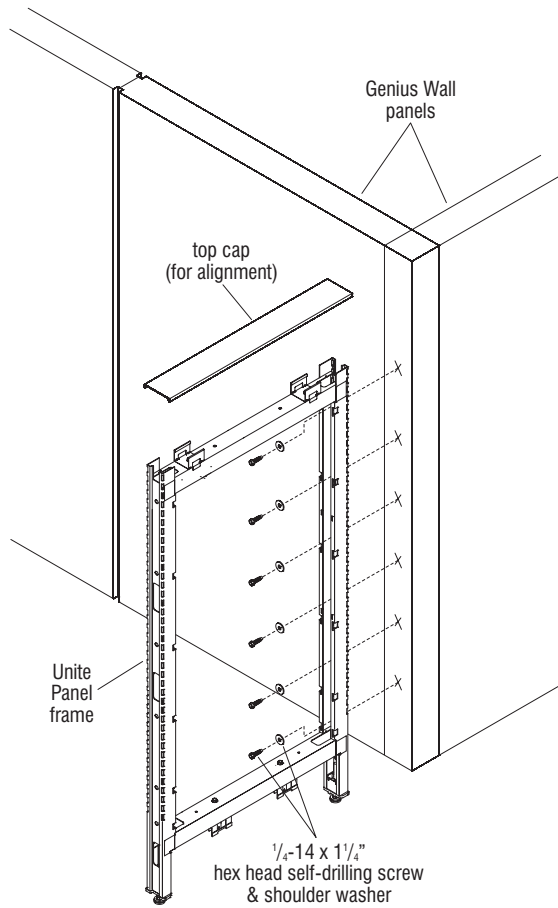

Figure 24 - Unite to Genius Wall Universal Installation



Assemble units as described herein only. To do otherwise may result in instability. All screws, nuts and bolts must be tightened securely and must be checked periodically after assembly. Failure to assemble properly, or to secure parts may result in assembly failure and personal injury.

### Electrical Installation - Overview

**Important:** Assembly of all frame components must be completed, with panel frames secure to each other and leveled prior to installation of electrical components.

Before installing electrical components, consult local inspectors and authorities for local codes. Connection to the building power supply may be made ONLY after all panel wiring has been completed. Building connections must be made by a licensed electrician, following local codes for the building site.

**Note:** Each circuit must be individually protected with a 120-volt, 20-amp circuit breaker device which will provide disconnect and overload protection.

Prior to beginning electrical component installation, read and understand the following electrical installation section and be familiar with the electrical components and all power infeed locations required.

**Note:** Data cable installation is not covered in this document. For data cable installation and management, refer to the Unite Planning Guide.

**Note:** The following steps show rigid wireways installing to frames before installation of power jumpers. However, some installers find it more convenient to install power jumpers before securing rigid wireways.

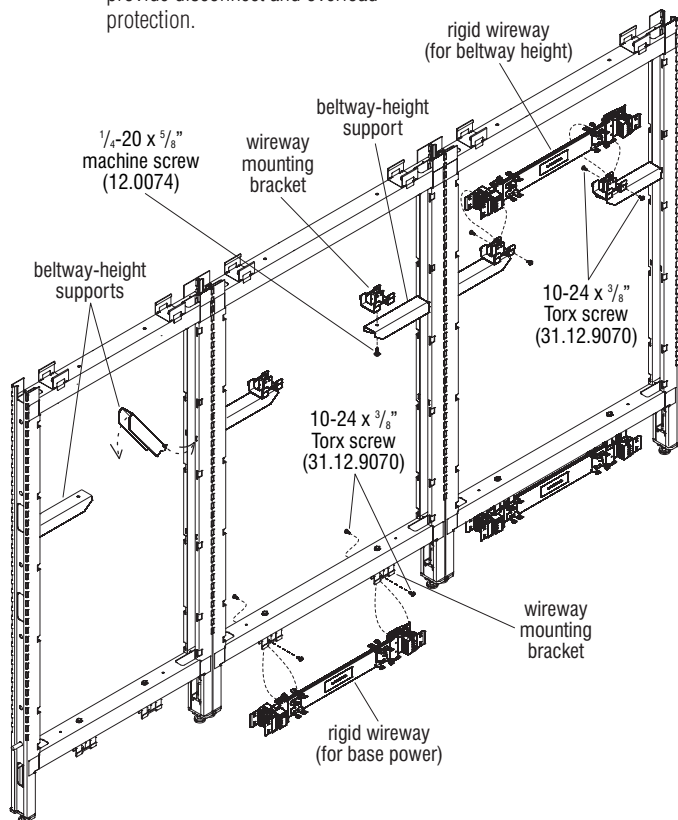

Figure 1 - Base & Beltway Rigid Wireways

### Base-Power Rigid Wireway

**Note:** Rigid wireways accept power infeeds, horizontal jumpers, vertical jumpers and duplex receptacles with simple modular snap connection. Rigid wireways must be installed with the "N" symbol oriented up.

1. Position the rigid wireway under the lower horizontal frame member (N symbol oriented up) such that mounting tabs on the wireway fit up between the two tangs of the wireway mounting bracket. Align all four mounting holes of the wireway with the four holes of the wireway mounting bracket, and secure using two #10-24 x 3/8" Torx screw (31.12.9070) per bracket, one from each side of the rigid wireway. Use the left mounting holes on one side of the bracket, and the right mounting holes on the other side of the bracket so that mounting screws do not interfere with each other (Figure 1).

2. Repeat the above base power rigid wireway installation for all panels that are powered, or will have power passing through them, per your space-planning layout (Figure 1).

**Note:** If vertical power jumpers are to be used between base power and beltway rigid wireways in any panel frame, refer to page 24, Figure 2 as vertical power jumpers should be installed before rigid wireways.

### Beltway-Height Power Rigid Wireway

**Note:** Rigid wireways accept power infeeds, horizontal power jumpers, vertical power jumpers

and duplex receptacles with simple modular snap connection. Rigid wireways must be installed with the "N" symbol oriented up.

1. At 30" beltway height, install beltway-height supports into the vertical frame member by tipping the inside of each support up, inserting the hook-tabs into the vertical slots, and rotating the support down into horizontal position as illustrated. Repeat for second required beltway-height support across from the first (Figure 1).
2. Install a wireway mounting bracket to the mounting hole of each beltway-height support using 1/4-20 x 5/8" machine screw (12.0074), as illustrated from underneath each support. Make sure bracket is aligned straight onto support before tightening (Figure 1).
3. Position a rigid wireway above the pair of beltway-height wireway mounting brackets (N symbol oriented up) such that mounting tabs on the wireway fit in between the two tangs of the wireway mounting bracket. Align all four mounting holes of the wireway with the four holes of the wireway mounting brackets, and secure using #10-24 x 3/8" Torx screw (31.12.9070) screws per bracket, one from each side of the rigid wireway. Use the left mounting holes on one side of the bracket, and the right mounting holes on the other side of the bracket so that mounting screws do not interfere with each other (Figure 1).
4. Repeat the above beltway-height power rigid wireway installation for all panels that are powered, or will have power passing through them at beltway height, per your space planning layout (Figure 1).



Assemble units as described herein only. To do otherwise may result in instability. All screws, nuts and bolts must be tightened securely and must be checked periodically after assembly. Failure to assemble properly, or to secure parts may result in assembly failure and personal injury.

### Vertical Power Jumper

**Note:** Vertical jumpers pass power vertically between base-power rigid wireways and beltway-height rigid wireways. It is much easier to connect the vertical power jumper to each wireway prior to installing wireways to wireway mounting brackets.

1. At the location specified for a vertical jumper, route the jumper into the vertical post cavity of the panel frame, and route the ends out just above and below the wireway mounting brackets as illustrated (Figure 2).
2. Snap the lower vertical wireway end into the base-power rigid wireway, and attach wireway to the wireway mounting brackets as described on page 23, Figure 1. Next, snap the upper vertical wireway end into the beltway-power rigid wireway and secure wireway to wireway mounting brackets on beltway-height support (Figure 2).

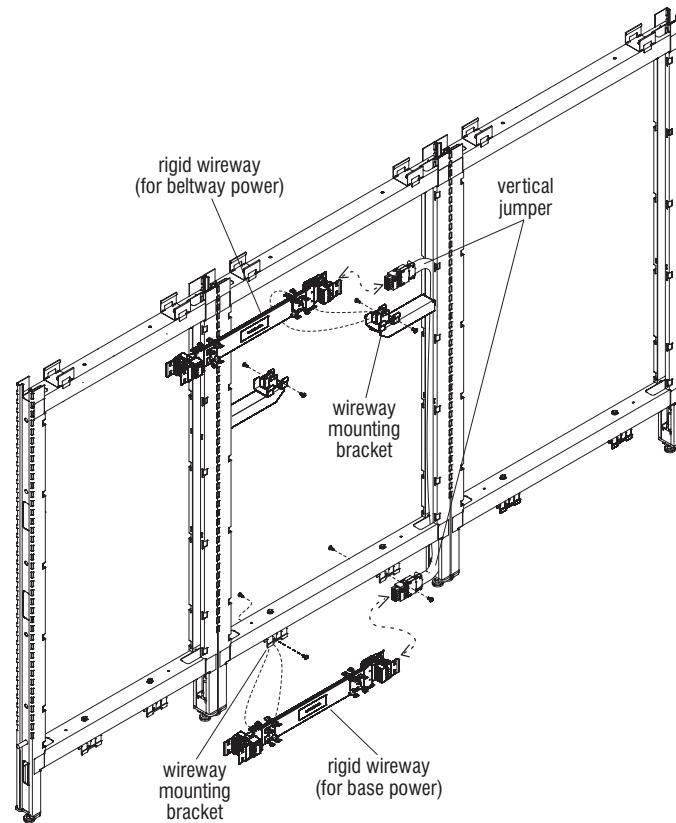

Figure 2 - Base to Beltway Vertical Jumper





Assemble units as described herein only. To do otherwise may result in instability. All screws, nuts and bolts must be tightened securely and must be checked periodically after assembly. Failure to assemble properly, or to secure parts may result in assembly failure and personal injury.

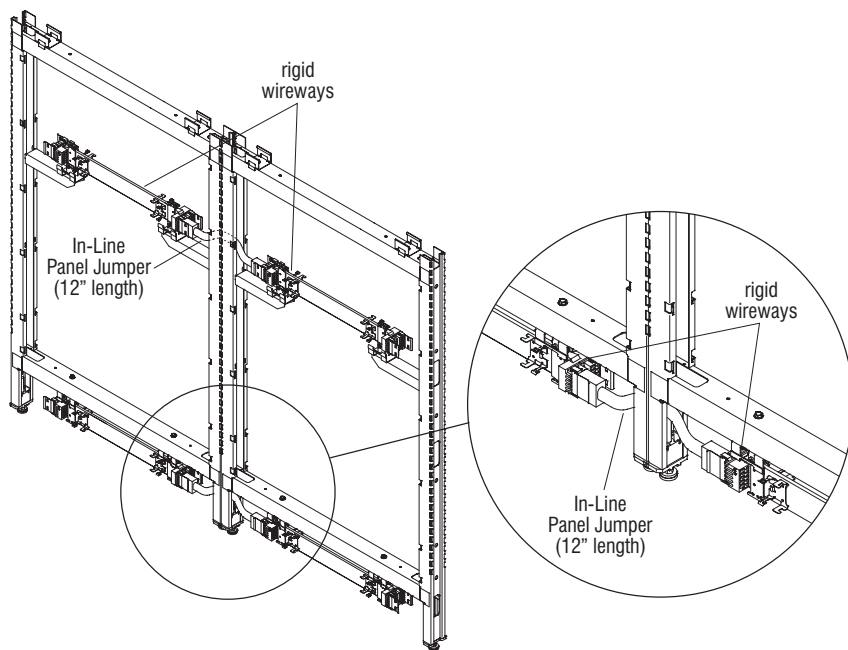

Figure 3 - 180° In-line Panel Jumper, 12" length

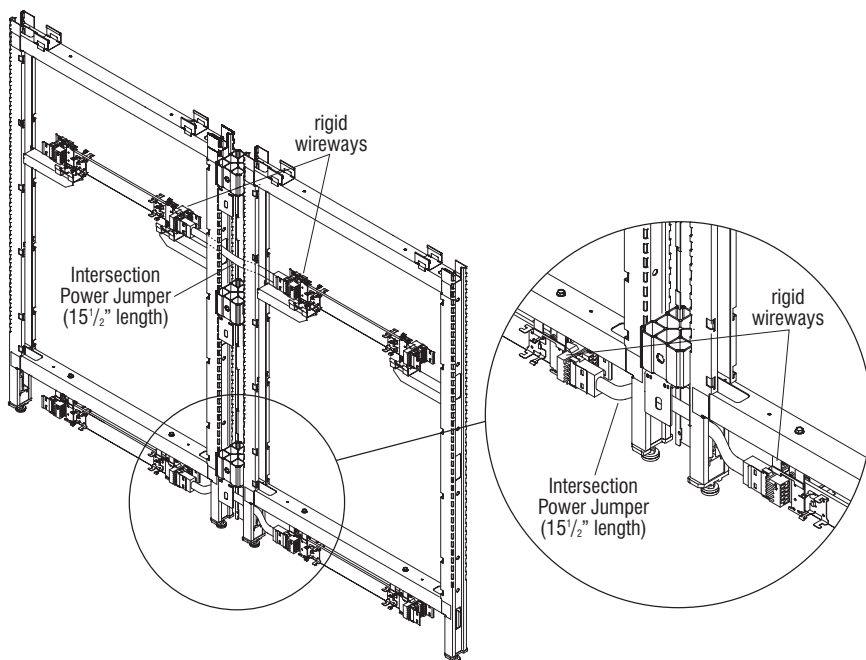

Figure 4 - 180° Intersection Panel Jumper with 3 1/2" Module Spacer, 15 1/2" length

### Horizontal In-Line Panel Jumpers

**Note:** Horizontal panel jumpers pass power between rigid wireways, from one panel to another. "In-Line (INL) Panel Jumpers" are 12" in length and are for in-line panel to panel connections only. "Intersection (INT) Panel Jumpers" are 15 1/2" long and are used for panel to panel conditions at intersections (90°, 120°, or 180°).

1. At the location specified for a horizontal jumper, route the panel jumper through the holes in the vertical posts between the panels, then plug the ends into each rigid wireway (Figures 3 through 9).

■ Unite® Panel System - Electrical Installation  
Assembly Instructions



Assemble units as described herein only. To do otherwise may result in instability. All screws, nuts and bolts must be tightened securely and must be checked periodically after assembly. Failure to assemble properly, or to secure parts may result in assembly failure and personal injury.

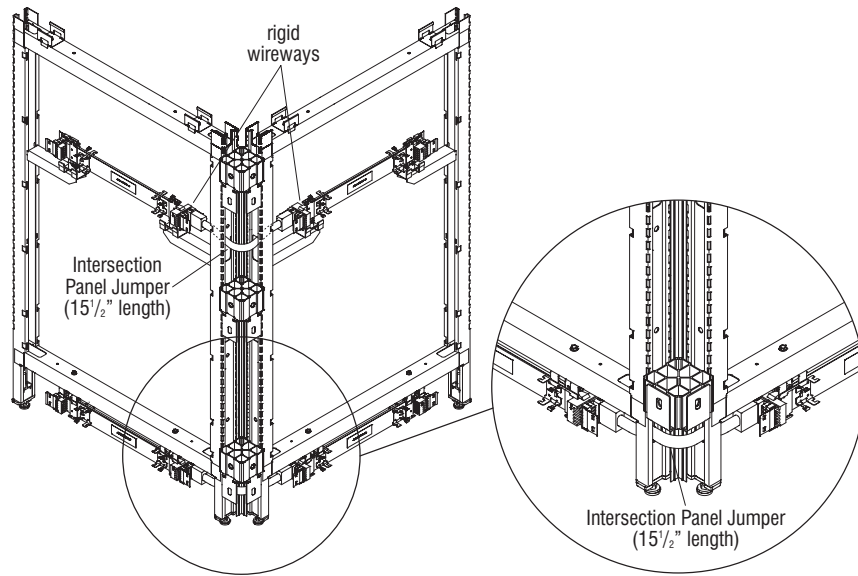

Figure 5 - 90° Corner (2-way) Panel Jumpers, 15 $\frac{1}{2}$ ” Length

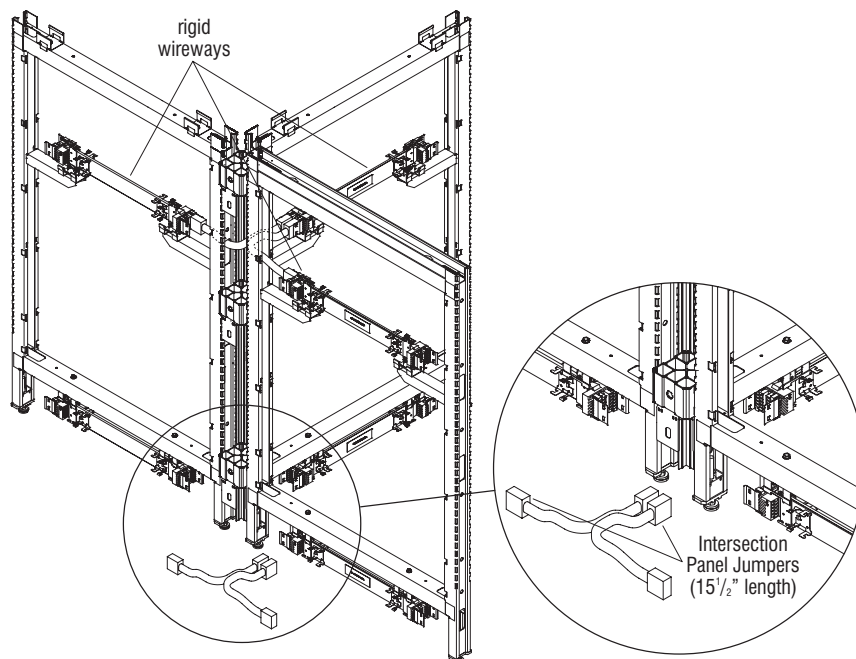

Figure 6 - 90° 3-Way Panel Jumpers, 15 $\frac{1}{2}$ ” Length



Assemble units as described herein only. To do otherwise may result in instability. All screws, nuts and bolts must be tightened securely and must be checked periodically after assembly. Failure to assemble properly, or to secure parts may result in assembly failure and personal injury.

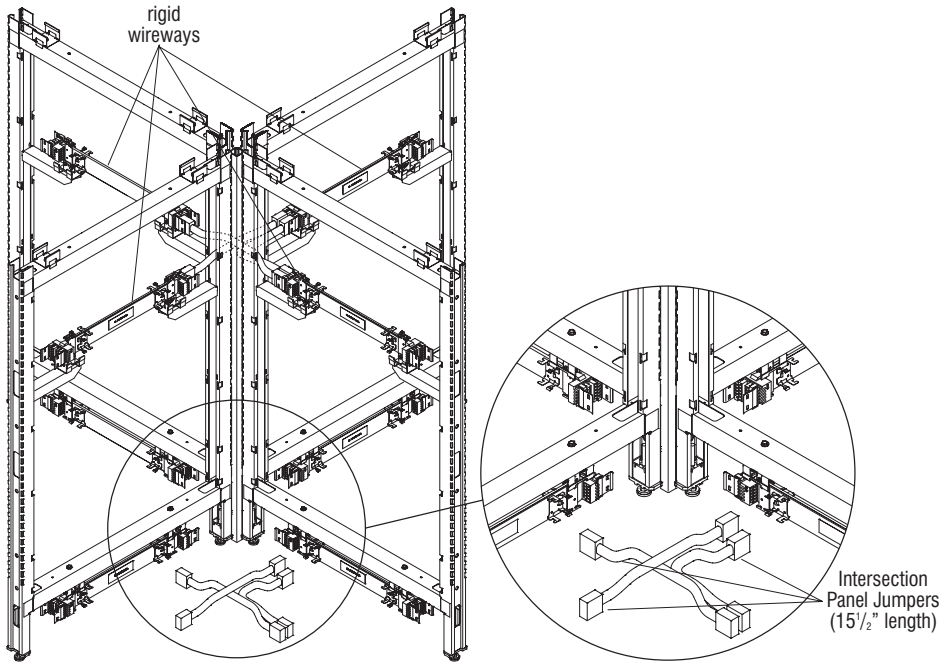

Figure 7 - 90° 4-Way Panel Jumpers, 15 1/2" Length



Assemble units as described herein only. To do otherwise may result in instability. All screws, nuts and bolts must be tightened securely and must be checked periodically after assembly. Failure to assemble properly, or to secure parts may result in assembly failure and personal injury.

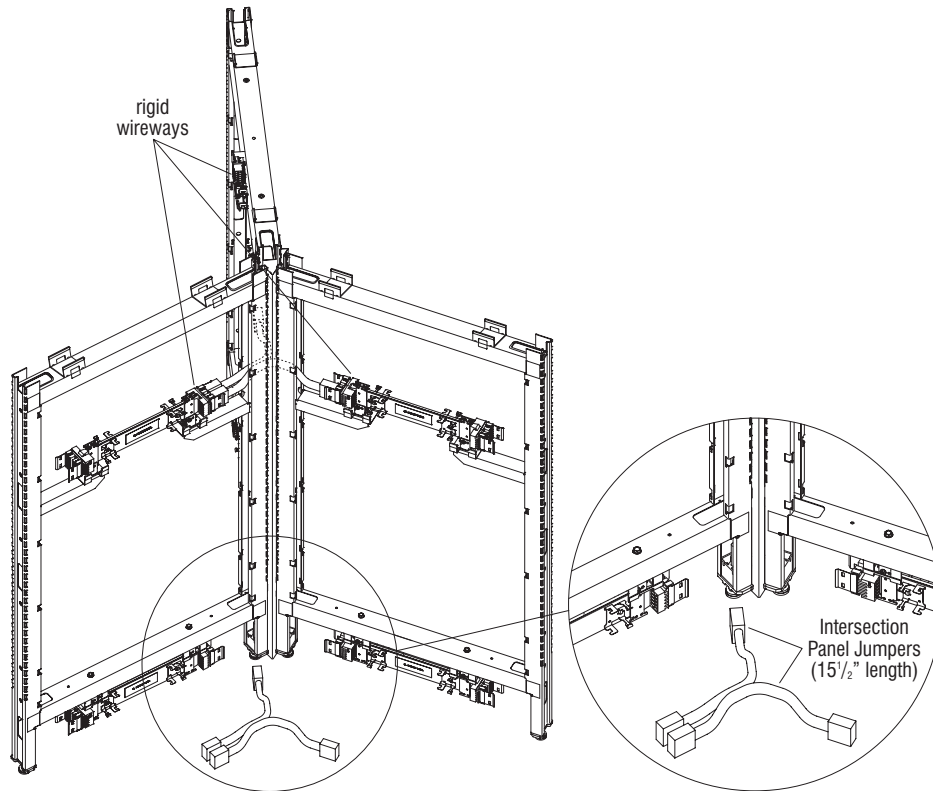

Figure 8 - 120° 3-Way Panel Jumpers, 15 1/2" Length

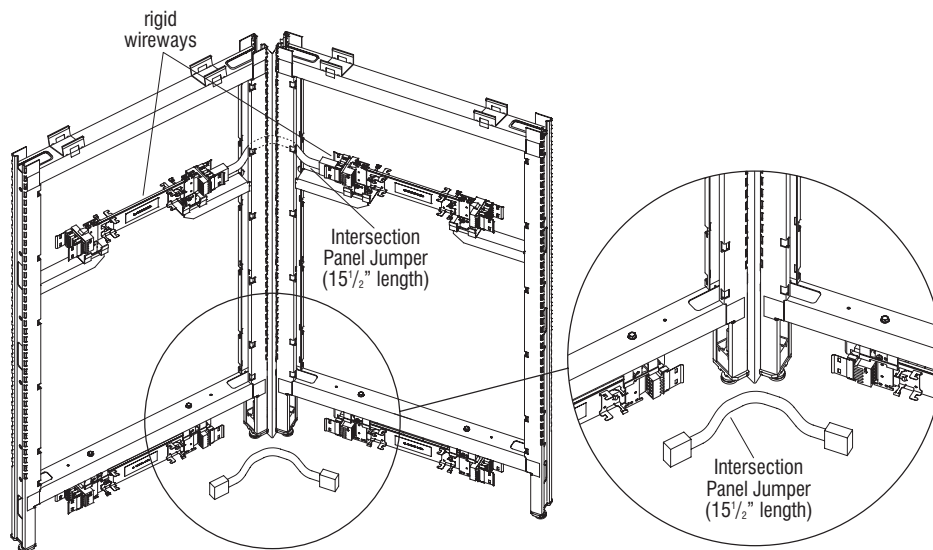
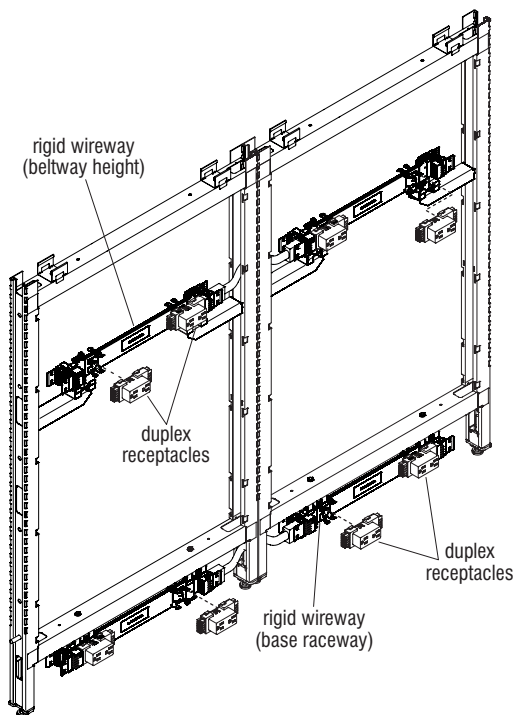

Figure 9 - 120° 2-Way Panel Jumper, 15 1/2" Length



Assemble units as described herein only. To do otherwise may result in instability. All screws, nuts and bolts must be tightened securely and must be checked periodically after assembly. Failure to assemble properly, or to secure parts may result in assembly failure and personal injury.



**Figure 10 - Duplex Receptacles**

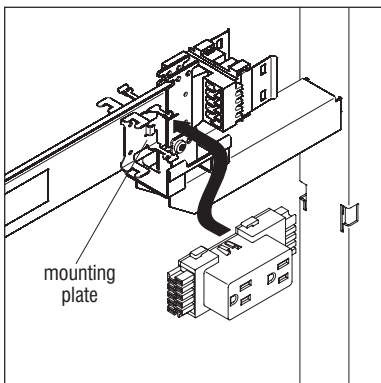

**Detail A**

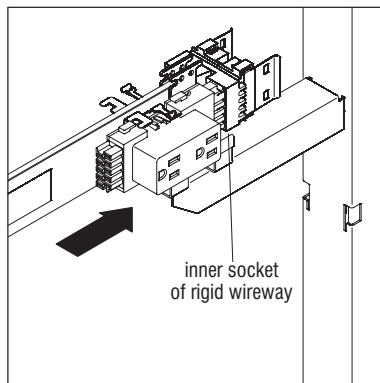

**Detail B**

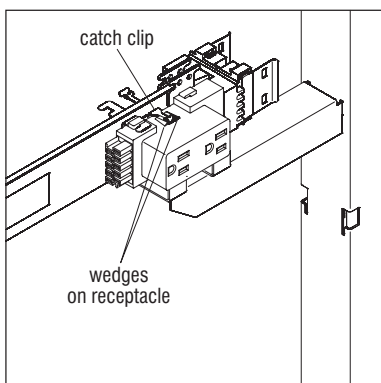

**Detail C**

**Duplex Receptacle Installation**

**Note:** Duplex receptacles for the 10-wire system must be specified/ordered separately. There are six receptacles available for accessing one of each of the six circuits of the 10-wire system. They are designed with a numeral on each (i.e. 1, 2, 3, 4, 5, & 6). Circuits 4, 5 and 6 have orange triangles to identify them as isolated circuits. To install the receptacles, follow the steps below.

**WARNING:** Assembly of all mechanical components must be completed before making any electrical connections. All electrically connected furnishings must also be mechanically connected.

1. Per the space-planning layout, determine the correct location for each numbered receptacle in the system (Figure 10).
2. Position the duplex receptacle on either end of the rigid wireway as shown, matching the arrow at the "N" symbol to the same orientation on both the receptacle and the wireway (Figure 10).
3. Align the receptacle so the end is inline with the inner socket on the rigid wireway and push the receptacle back against the mounting plate (Detail A).
4. Slide the receptacle to the side so the end terminals slide into the rigid wireway's inner socket (Detail B).
5. Receptacle is properly seated when the catch clip on the wireway is snapped in between the wedges on the receptacle (Detail C).

# Unite® Panel System - Power Infeed Installation

## Assembly Instructions



Assemble units as described herein only. To do otherwise may result in instability. All screws, nuts and bolts must be tightened securely and must be checked periodically after assembly. Failure to assemble properly, or to secure parts may result in assembly failure and personal injury.

### Standard Base Power Infeed Installation

**Note:** All panels must be mechanically connected together, with all rigid wire-ways and panel-to-panel power connections appropriately installed before adding power infeed.

1. At the bottom of the panel frame which will receive base power infeed, install two plastic base raceway hinge clips by nesting the hooks of the clips into the two slots in glide housing top, then press down to snap hinge clip into place (Figure 11 & Detail D).
2. Per the space-planning layout, determine the location(s) for base raceway power infeed. Position the base infeed adapter plug with the arrow at the "N" facing up and slide into place on the rigid wireway in the same manner as installing a receptacle. Push the infeed adapter into the wireway female connection until the snap-clip on the wireway captures the adapter, locking it into place (Figure 11).
3. Install the base raceway cover to the power infeed panel by first aligning the slots at the bottom of the base raceway cover with the bumps at the bottom of the base raceway hinge clips. After both ends are engaged to hinge clips at the bottom, rotate the top of the base raceway cover up toward the frame and snap the top onto the rigid wireway mounting bracket to secure (Figure 11 & Detail E).
4. Snap the bezel plate into the base raceway cover, then connect the base raceway power infeed to the adapter plug in the desired direction. The base infeed can be rotated 180° and installed in one of two directions. Snap the lock bar onto the power infeed to secure and place the base infeed shroud over the infeed and secure with screw provided (Figure 11).

**Note:** The power infeeds are to be connected to the power source by a qualified electrician who must follow all state and local codes at the building site and check the electrical integrity of the finished system.

5. If a base infeed is located between a panel and the building wall, the panels must be located at least 1.75" away from the wall to provide adequate clearance (Detail F). Alternately, the base infeed can be connected on the side opposite the building wall, and the conduit can be run under the panel wall, and up between the panel and building wall to be connected to the power source. This option requires a minimum of 1.0" clearance between the panel wall and the building wall for the base infeed cable to enter the junction box on the wall (Detail G).

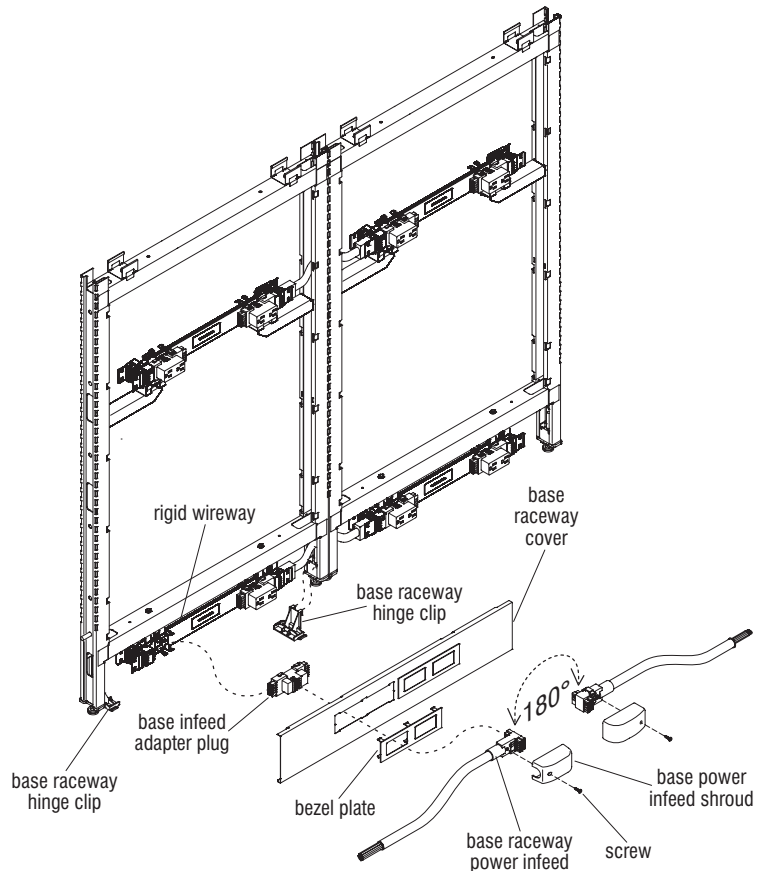
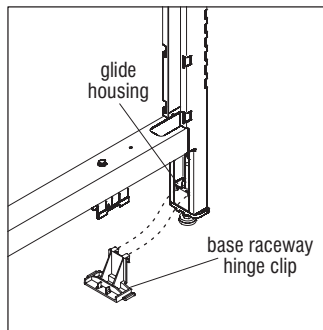
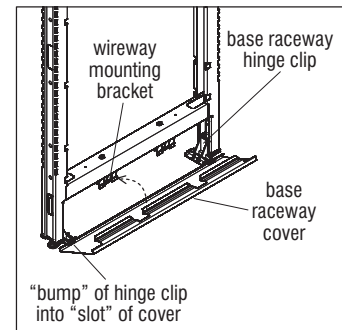

Figure 11 - Base Raceway Power Infeed



Detail D



Detail E

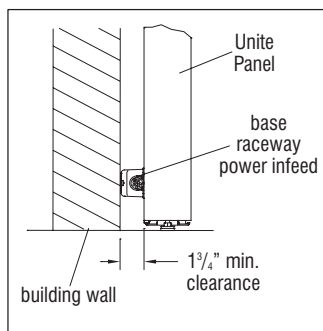

Detail F

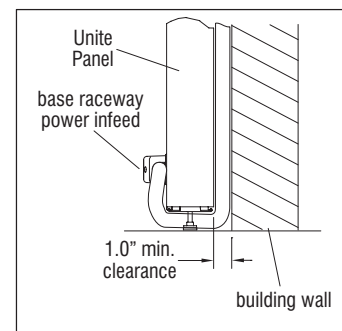

Detail G



Assemble units as described herein only. To do otherwise may result in instability. All screws, nuts and bolts must be tightened securely and must be checked periodically after assembly. Failure to assemble properly, or to secure parts may result in assembly failure and personal injury.

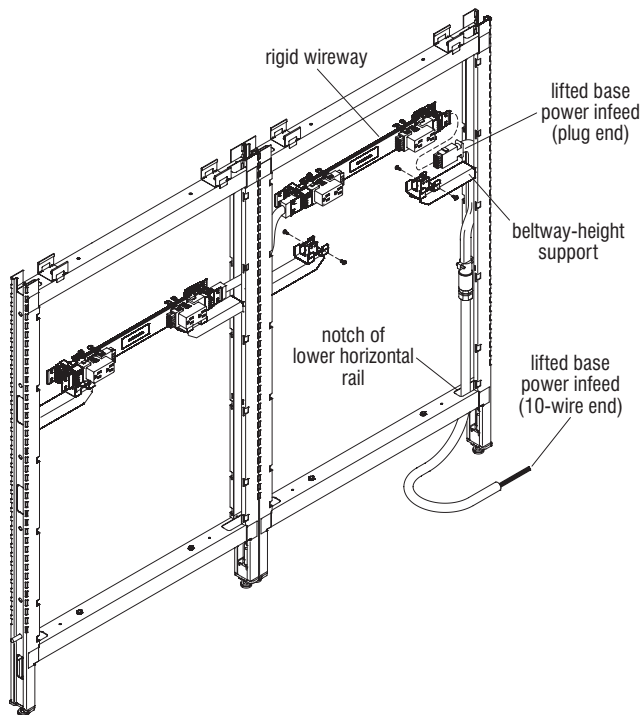

Figure 12 - Lifted Base Power Infeed

### Lifted Base Power Infeed Installation

**Note:** All panels must be mechanically connected together, with all rigid wireways and panel-to-panel power connections appropriately installed before adding power infeed, or connecting infeed to power source.

1. Position the lifted base power infeed inside the vertical channel of the frame upright, and route the plug end of the infeed up and over the top of the beltway-height support bracket as illustrated (Figure 12).

**Note:** It is easier to plug the power infeed into the rigid wireway if the wireway is disconnected from the beltway-height support brackets first.

2. Remove the screws attaching the rigid wireway to the beltway-height support brackets, move the wireway away slightly and plug the power infeed into the rigid wireway. Once secure, re-attach wireway to support brackets (Figure 12).
3. Lastly, route the 10-wire end of conduit down through the notch in the lower horizontal rail next to the vertical frame upright and let rest on the floor (Figure 12)

**Note:** The power infeeds are to be connected to the power source by a qualified electrician who must follow all state and local codes at the building site and check the electrical integrity of the finished system.



Assemble units as described herein only. To do otherwise may result in instability. All screws, nuts and bolts must be tightened securely and must be checked periodically after assembly. Failure to assemble properly, or to secure parts may result in assembly failure and personal injury.

**Top Infeed Power Installation**

**Note:** All panels must be mechanically connected together, with all rigid wireways and panel-to-panel power connections appropriately installed before adding power infeed, or connecting infeed to power source.

1. Make sure that panel to receive top power infeed is in its final location, and is plumb and level. At the location where the top infeed power pole will set, place a power pole retaining clip inside the top trough of the upper horizontal frame member, with the open end of the clip facing the end of the frame. Snap the clip into place so it sits firmly in the bottom of the trough (Figure 13).
2. Loosely set the top infeed panel trim cap onto the upper horizontal frame, with the power pole cut-out location right over the power pole retaining clip (Figure 13).
3. At the ceiling, directly above the location where the top power infeed will exit the panel, drop a plumb line to a corner of the infeed opening in the top infeed trim cap, transfer that location to the ceiling, then carefully mark and cut hole in the ceiling ( $\frac{1}{4}$ " larger than the inside hole dimension of the top infeed panel trim cap) for the top infeed power pole to go through at a later step.
4. Position the 10-wire top power infeed inside the vertical channel of the panel frame upright, and route the plug end of the infeed down through the notch in the lower horizontal rail as illustrated (Figure 13).

**Note:** It is easier to plug the power infeed into the rigid wireway if the wireway is disconnected from the wireway mounting brackets first.

5. Remove the screws attaching the rigid wireway to the wireway mounting brackets, move the wireway away slightly and plug the power infeed into the rigid wireway. Once secure, re-attach wireway to mounting brackets (Figure 13).

**Note:** The top infeed power pole consists of an assembly of three extruded pieces which must be cut to proper length. The outer pieces are covers. The inner piece has a smaller cavity for running data, and the larger cavity is for running power infeed.

6. Place the assembled top infeed power pole next to the panel at the infeed location, and orient the pole straight up so the top of the pole touches the ceiling. Add 4" to the distance from the ceiling to the top of the panel frame, then mark and cut the three pieces of the aluminum top infeed power pole to that length.

**Note:** The top infeed power pole extrusion cover for the power cavity is shown removed in Figure 13. Pole and power can be run up into the ceiling in different ways, with the covers on or off for power and data installation. The steps below outline just one way.

7. Route the 10-wire end of conduit up through the top horizontal rail of the panel frame, through the power pole retaining clip, and the top infeed panel trim cap. Then push the 10-wire infeed up into the assembled, cut-to-size (step 6) top infeed power pole. Take a ceiling trim cap and bend the four tabs up, just less than 90° at the side that will face the ceiling (Figure 13). Slide the ceiling trim cap onto the top of the power pole and press it down 8". Push the 10-wire end of the power infeed up and out through the end of the power pole.

8. Push the top of the power pole up into the opening cut in the ceiling high enough to allow the bottom of the pole to move over and fit down through the rectangular hole in the top infeed panel trim cap. Set the bottom of the power pole down to rest on the power pole retaining clip (Figure 13).

9. Push the 10-wire power infeed the rest of the way up through the pole into the area above the ceiling and push the ceiling trim cap up tight to the ceiling, with tabs through ceiling opening (Figure 13 & Detail H).

**Note:** The top infeed trim cap must not be snapped into place until later when panel tiles are installed.

**Note:** The power infeeds are to be connected to the power source by a qualified electrician who must follow all state and local codes at the building site and check the electrical integrity of the finished system.

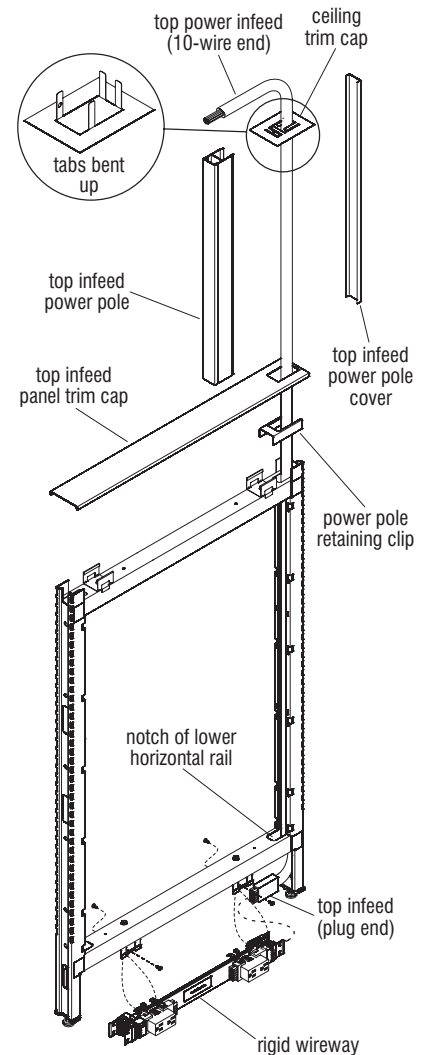

**Figure 13 - Top Infeed**

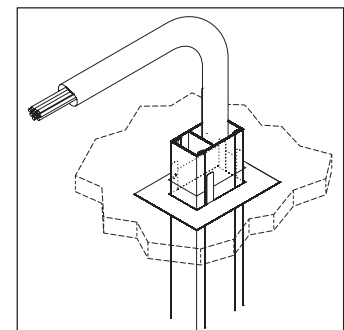

**Detail H**





Assemble units as described herein only. To do otherwise may result in instability. All screws, nuts and bolts must be tightened securely and must be checked periodically after assembly. Failure to assemble properly, or to secure parts may result in assembly failure and personal injury.

### New York Base Power Infeed Installation

**Note:** All panels must be mechanically connected together, with all rigid wireways and panel-to-panel power connections appropriately installed before adding power infeed, or connecting infeed to power source.

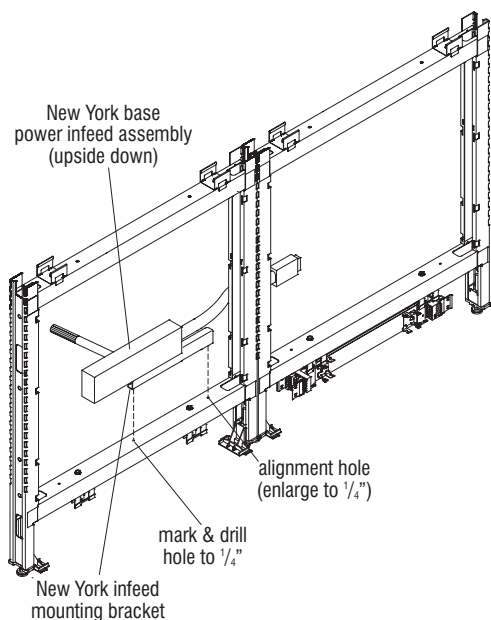

Figure 14 - New York Base Infeed

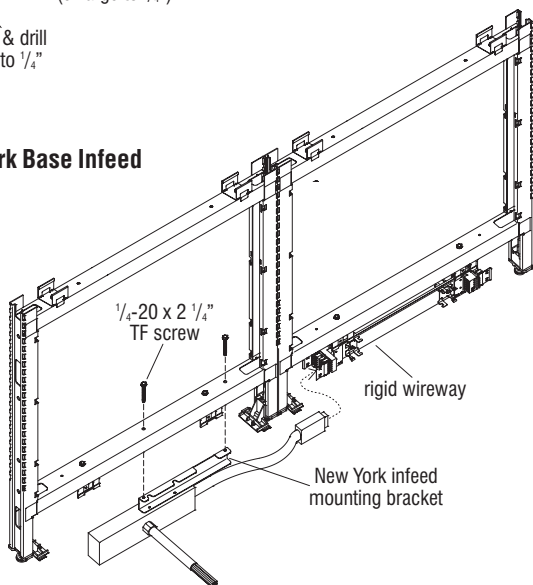

Figure 15 - New York Base Infeed

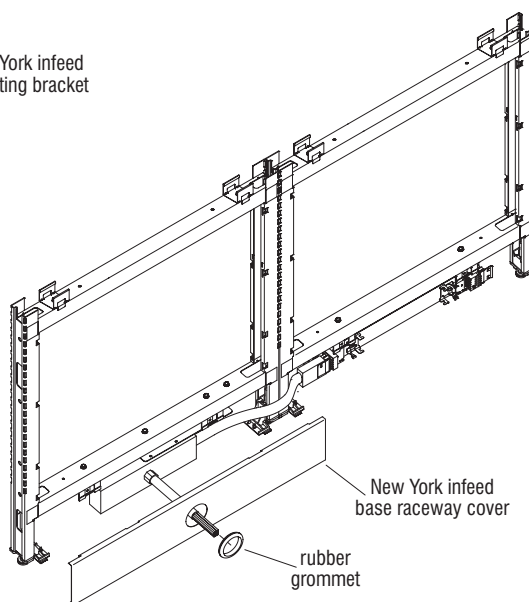

Figure 16 - New York Base Infeed

1. One mounting hole must be marked then drilled, and another must be enlarged for mounting of the New York infeed mounting bracket to the lower horizontal frame rail. To create mounting holes, first position the New York base power infeed assembly upside down on top of the lower horizontal rail as illustrated and align the mounting hole of the bracket to the pre-drilled hole closest the frame side rail. Be sure the infeed assembly is centered onto the horizontal rail, then use the New York infeed mounting bracket as a guide and mark the second mounting hole to the lower horizontal rail. Punch to center the hole location, then drill a hole  $1/4$ " diameter. At the first, alignment hole location, drill that  $11/64$ " hole out to  $1/4$ " (Figure 14).

2. Turn the New York base power infeed right side up as illustrated, and position under the lower horizontal frame rail. Insert and tighten two  $1/4$ -20 x  $2 1/4$ " thread-forming screws through the horizontal frame and into the New York infeed mounting bracket (Figure 15).

3. Route the plug-end of the power infeed around the panel vertical rails, and press the plug into the adjacent panel rigid wireway, snapping in to secure (Figure 15).

**Note:** It is easier to plug the power infeed into the rigid wireway if the wireway is disconnected from the wireway mounting brackets first.

4. Install the unique New York infeed base raceway cover as illustrated, and install rubber grommet (Figure 16).

**Note:** The power infeeds are to be connected to the power source by a qualified electrician who must follow all state and local codes at the building site and check the electrical integrity of the finished system.

## ■ Unite® Panel System - Power Infeed Installation

Assembly Instructions



Assemble units as described herein only. To do otherwise may result in instability. All screws, nuts and bolts must be tightened securely and must be checked periodically after assembly. Failure to assemble properly, or to secure parts may result in assembly failure and personal injury.

### New York Top Power Infeed Installation

**Note:** All panels must be mechanically connected together, with all rigid wire-ways and panel-to-panel power connections appropriately installed before adding power infeed, or connecting infeed to power source.

1. One mounting hole must be marked then drilled, and another must be enlarged for mounting of the New York infeed mounting bracket to the lower horizontal frame rail. To create mounting holes, first position the New York top power infeed assembly upside down on the lower horizontal rail as illustrated and align the mounting hole of the bracket to the pre-drilled hole closest the frame side rail. Be sure the infeed assembly is centered onto the horizontal rail using the New York infeed mounting bracket as a guide and mark the second mounting hole to the lower horizontal rail. Drill a hole  $\frac{1}{4}$ " diameter at the second marked location. At the first alignment hole location, drill the  $\frac{11}{64}$ " hole out to  $\frac{1}{4}$ " (Figure 17).

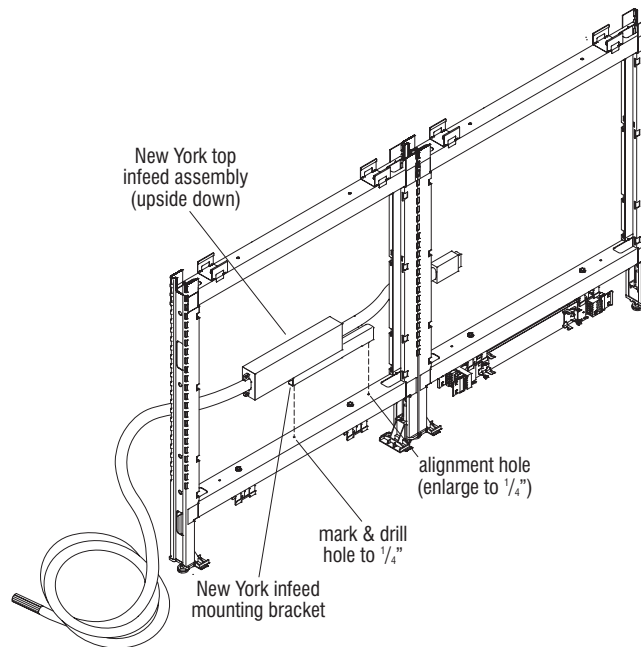

Figure 17 - New York Top Power Infeed



Assemble units as described herein only. To do otherwise may result in instability. All screws, nuts and bolts must be tightened securely and must be checked periodically after assembly. Failure to assemble properly, or to secure parts may result in assembly failure and personal injury.

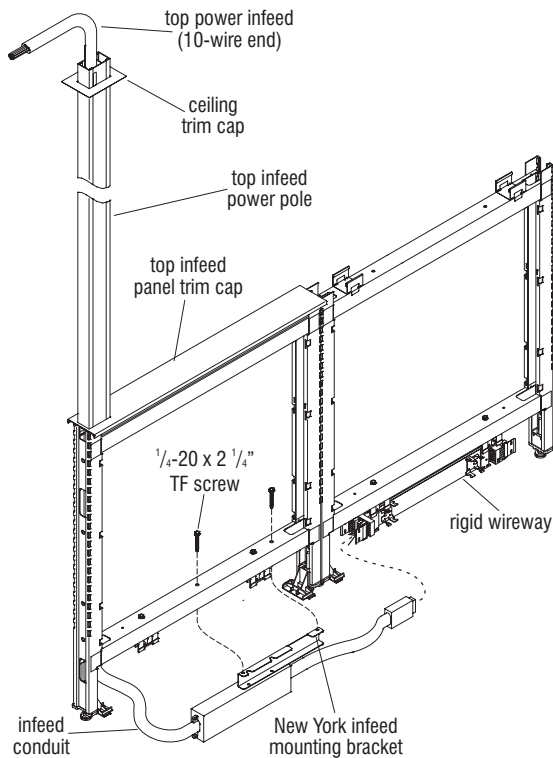
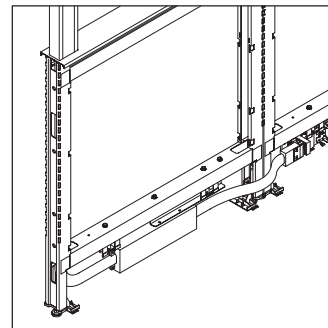

Figure 18 - New York Top Infeed



Detail I

2. Turn the New York top infeed assembly right side up as illustrated and route the 10-wire end of the infeed up through the notch under the lower horizontal rail and into the vertical channel of the panel frame upright and let sit. Position the New York infeed mounting bracket under the horizontal frame as illustrated and secure using two 1/4-20 x 2 1/4" thread-forming screws through the horizontal frame and into the New York infeed mounting bracket (Figure 18).

**Note:** It is easier to plug the power infeed into the rigid wireway if the wireway is disconnected from the wireway mounting brackets first.

3. Route the plug-end of the power infeed around the panel vertical rails, and press the plug into the adjacent panel rigid wireway, snapping in to secure (Figure 18 & Detail I).
4. Refer back to "Top Power Infeed Installation", page 32, steps 1 through 9 for installation of power pole to ceiling and to top infeed trim cap (Figure 18 & Detail I)

**Note:** The power infeeds are to be connected to the power source by a qualified electrician who must follow all state and local codes at the building site and check the electrical integrity of the finished system.

# Unite® Panel System - Power Infeed Installation

## Assembly Instructions



Assemble units as described herein only. To do otherwise may result in instability. All screws, nuts and bolts must be tightened securely and must be checked periodically after assembly. Failure to assemble properly, or to secure parts may result in assembly failure and personal injury.

### Chicago Hardwire Base Power Infeed Installation - 24" & 30" Panel Width

**Important:** All panels must be mechanically connected together, with all rigid wire-ways and panel-to-panel power connections appropriately installed before adding power infeed, or connecting infeed to power source.

**Note:** The Chicago Hardwire steel receptacle boxes may mount to open at both sides of the panel base, but the boxes are staggered to not be back-to-back. Panels of 24" or 30" wide can accommodate only one receptacle box per side, while 36" through 72" wide panels can accommodate two receptacle boxes per side.

### Chicago Hardwire - 24" & 30" Panel Width

1. Position a Z-bracket to the back of a steel receptacle box, and attach bracket to box using two  $\frac{1}{4}$ -20 x  $\frac{5}{16}$ " Phillips thread-forming screws (46.0195) as illustrated (Detail J). Assemble all remaining panel boxes and Z-brackets together at this time. The receptacle box & Z-bracket assemblies are non-handed, so can be used on either side of the panel.
2. Using two  $\frac{1}{4}$ -20 x  $\frac{5}{16}$ " Phillips thread-forming screws, attach a Chicago mounting bracket to each receptacle box & Z-bracket assembly as illustrated. Orient the parts for assembly such that the screw goes through the Chicago bracket and threads into the Z-bracket (Figure 19).
3. If the lower panel frame rail has two brackets mounted under it, remove the  $\frac{1}{4}$ -20 x  $2\frac{1}{4}$ " thread-forming screws (46.0195) securing them. Discard the brackets but retain the thread-forming screws. Orient the

Chicago mounting brackets (with receptacle & Z-bracket attached) under the holes in the lower panel frame rail and secure the Chicago mounting brackets to the frame rail using a  $\frac{1}{4}$ -20 x  $2\frac{1}{4}$ " thread-forming screw (Figure 19).

**Note:** The power infeeds are to be connected to the power source by a qualified electrician who must follow all state and local codes at the building site and check the electrical integrity of the finished system.

4. Install conduit, wiring and receptacles per Chicago Electrical Codes.
5. Place a Chicago filler plate over the receptacle box as illustrated and secure with two filler plate screws (Figure 19).

6. Install Chicago base raceway covers in the same manner as standard Unite. Chicago base raceway covers are different than standard as the cut-outs are in unique locations for this application (Figure 19).
7. Snap the Chicago bezel plate into the Chicago base raceway cover. Chicago bezel plates are different than standard as they have the  $\frac{1}{2}$ " deep snap tabs removed. Snap the data filler plates into the Chicago bezel plates if no data cables are used at that location. The data port accepts modular furniture data port covers or data jacks (Figure 19).

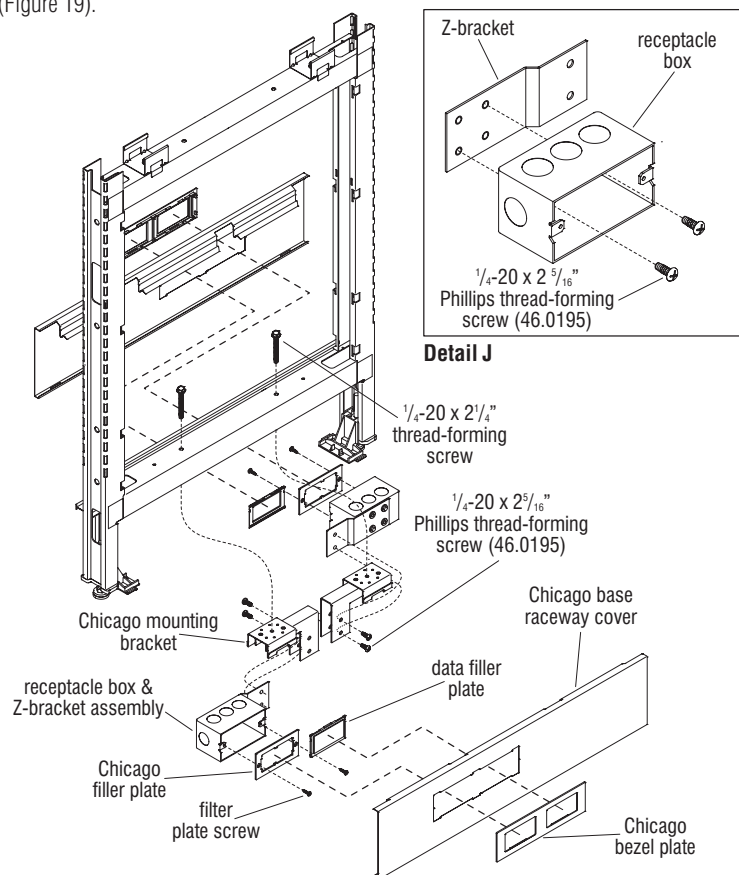

Figure 19 - Chicago Hardwire - Base Power Infeed - 24" & 30" Panel Width



Assemble units as described herein only. To do otherwise may result in instability. All screws, nuts and bolts must be tightened securely and must be checked periodically after assembly. Failure to assemble properly, or to secure parts may result in assembly failure and personal injury.

**Chicago Hardwire Base Power Infeed Installation - 36" through 72" Panel Widths**

**Note:** The Chicago Hardwire steel receptacle boxes may mount to open at both sides of the panel base, but the boxes are staggered to not be back-to-back. Panels of 24" or 30" wide can accommodate only one receptacle box per side, while 36" through 72" wide panels can accommodate two receptacle boxes per side.

**Chicago Hardwire - 36 through 72" Panel Width**

1. Position a Z-bracket to the back of a steel receptacle box, and attach bracket to box using 1/4-20 x 5/16" Phillips thread-forming screws (46.0195) as illustrated (Detail K). Assemble all remaining panel boxes and Z-brackets together at this time. The receptacle box & Z-bracket assemblies are non-handed, so can be used on either side of the panel.

2. Using 1/4-20 x 5/16" Phillips thread-forming screws (46.0195) screws, attach a Chicago mounting bracket to each receptacle box & Z-bracket assembly as illustrated. For 36" through 72" wide panels, two panel box & Z-bracket assemblies will attach to each Chicago mounting bracket, to face the outside of each side of the panel. Orient the parts for assembly such that the screw goes through the Chicago bracket and threads into the Z-bracket (Figure 20).

3. If the lower panel frame rail has two brackets mounted under it, remove the 1/4-20 x 2 1/4" thread-forming screws securing them. Discard the brackets but retain the screws. Orient the Chicago mounting brackets (with receptacle & Z-bracket attached) under the holes in the lower panel frame rail and secure the Chicago mounting brackets to the frame rail using a 1/4-20 x 2 1/4" screw (Figure 20).

**Note:** The power infeeds are to be connected to the power source by a qualified electrician who must follow all state and local codes at the building site and check the electrical integrity of the finished system.

4. Install conduit, wiring and receptacles per Chicago Electrical Codes.
5. Place a Chicago filler plate over the receptacle box as illustrated and secure with two filler plate screws (Figure 20).
6. Install Chicago base raceway covers in the same manner as standard Unite. Chicago base raceway covers are different than standard as the cut-outs are in unique locations for this application (Figure 20).
7. Snap the Chicago bezel plate into the Chicago base raceway cover. Chicago bezel plates are different than standard as they have the 1/2" deep snap tabs removed. Snap the data filler plates into the Chicago bezel plates if no data cables are used at that location. The data port accepts modular furniture data port covers or data jacks (Figure 20).

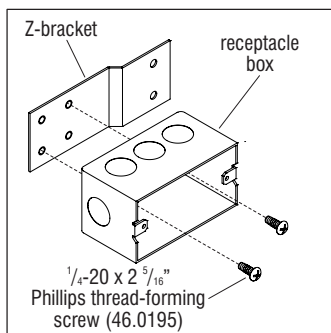

**Detail K**

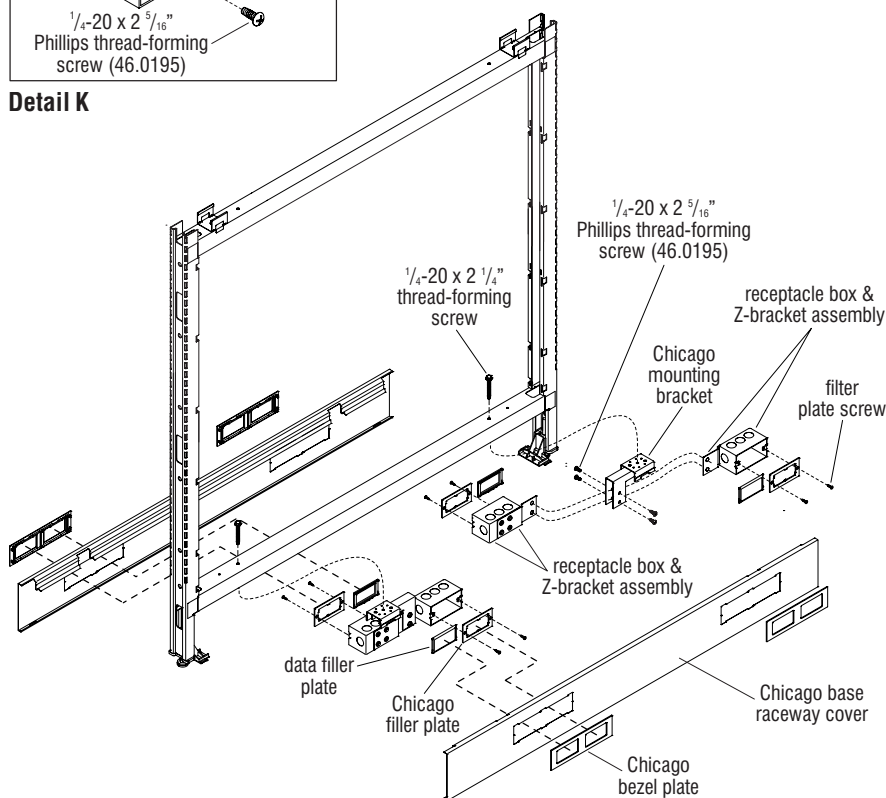

**Figure 20 - Chicago Hardwire - Base Power Infeed - 36" through 72" Panel Widths**

# Unite® Panel System - Tile Installation

## Assembly Instructions



Assemble units as described herein only. To do otherwise may result in instability. All screws, nuts and bolts must be tightened securely and must be checked periodically after assembly. Failure to assemble properly, or to secure parts may result in assembly failure and personal injury.

### Fabric Tile Installation

**Note:** Standard Acoustic tiles have fabric surfaces, and the tiles attach to panel frames designed with base raceways or lifted raceways. Standard acoustic segmented tiles are split at beltway and are separated by "segmented H-trim channels".

**Note:** For installation of steel tiles and steel markerboard tiles, see page 39.

1. At the location of the panel frame where a "fabric tile" will rest, install a "bottom trim channel" into the "vertical posts". Position the bottom trim channel as illustrated. Hook the top lip into the bottom P-slot notches in the vertical posts. Push trim channel down into the slots to secure (Figure 1).

**Note:** Fabric (full-height & segmented) tiles have vertical stiffeners installed to the back side. At one end of each stiffener the tabs are extended out, and at the other end they are not. The end with the tabs extended is the top of the tile.

2. Position the fabric tile such that the "open tabs" at the top of the vertical tile stiffeners are at the top of the panel (Figure 2).
3. Hold the tile up, then center and nest the bottom of the tile into the bottom trim channel. Push the top of the tile against the frame and lift such that the tabs of the stiffeners enter the P-slots. Push in and gently allow tile to nest down into the bottom trim channel (Figure 2).

**Note:** Unite tiles do not hang from the stiffener tabs. Support of the tiles is provided by the bottom trim channel, or the segmented H-trim channel. The tabs simply keep the tile from tipping away from the frame.

4. If a panel is to have standard segmented tiles, install a segmented H-shape trim channel such that the wide flange of the channel is behind the tile as illustrated. Install segmented tiles from the bottom up. The lowest segmented tile installs first, then H-trim channel, then next higher segmented tile etc. (Figure 2).

**Note:** Eight inch high segmented tiles will have hook and loop pads instead of stiffener tabs for securing to vertical posts.

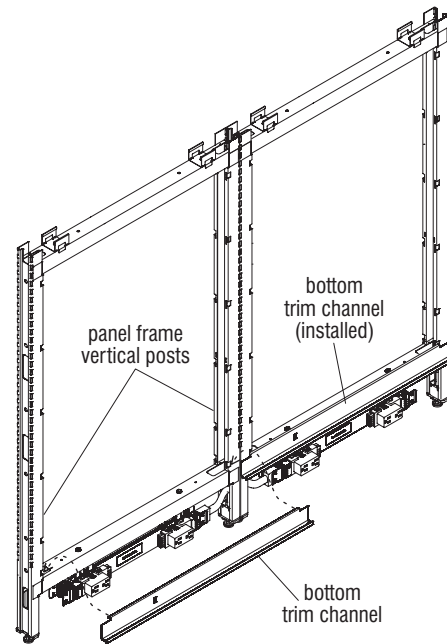

Figure 1 - Bottom Trim Channel Installation

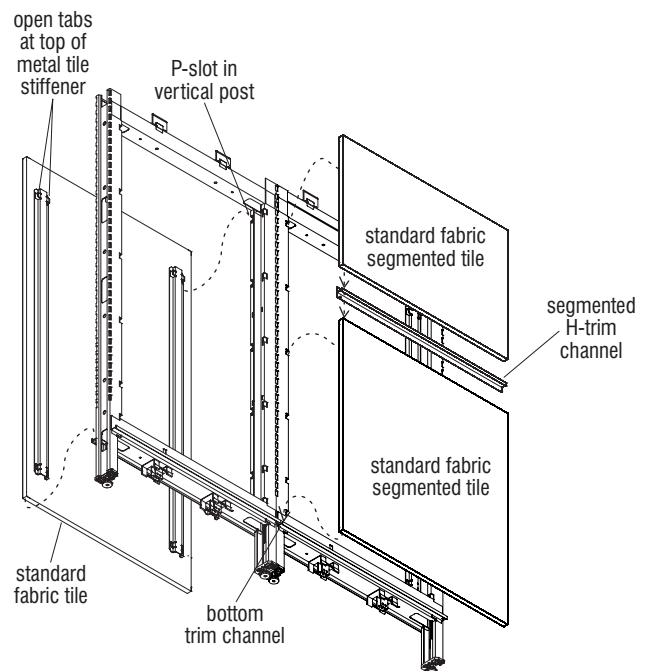



Figure 2 - Standard Tile Installation



**WARNING**

Rare Earth Magnets used with this product. The magnets can be harmful to pacemaker wearers and others with medical devices. **Pacemaker wearers should stay at least one foot away from the steel tiles.**



**CAUTION**

Assemble units as described herein only. To do otherwise may result in instability. All screws, nuts and bolts must be tightened securely and must be checked periodically after assembly. Failure to assemble properly, or to secure parts may result in assembly failure and personal injury.

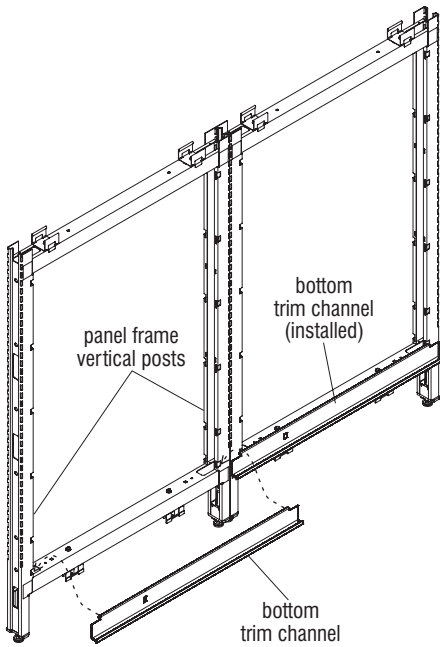

**Figure 1 - Bottom Trim Channel Installation**

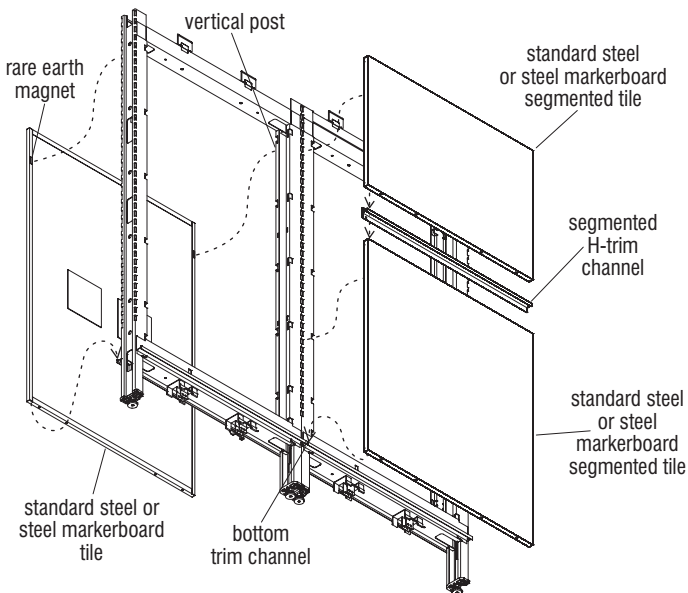

**Figure 2 - Standard Steel Tile or Steel Markerboard Installation**

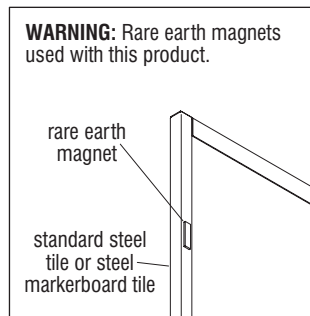

**Detail A**

**Steel Tile and Steel Markerboard Tile Installation**

**Note:** Assembly of all standard steel and steel markerboard tiles are different than standard fabric tiles. Instead of brackets and tabs like Unite fabric tiles, steel tiles have two pre-assembled magnets located on the back of the tile. Steps to assemble steel tiles remain similar to standard fabric tiles and require no tools.

1. At the bottom of the panel frame where a steel tile will rest, install a "bottom trim channel" to the "vertical posts". Position the bottom trim channel as illustrated. Hook the top lip into the vertical posts. Push trim channel down into the slots to secure (Figure 1).
2. Hold the tile up, then center and nest the bottom of the tile into the bottom trim channel. Push the top of the tile against the frame. Magnets will hold the tile against the frame (Figure 2 & Detail A).
3. If a panel has steel segmented tiles, install a segmented H-shape trim channel such that the wide flange of the channel is behind the tile as illustrated. Install segmented tiles from the bottom up (Figure 2).

**Note:** Unite tiles do not hang from the frame. Support of tiles is provided by the bottom trim channel or the segmented H-trim channel. Magnets simply keep the tile from tipping away from the frame until the top cap is installed providing final tile retention.

# ■ Unite® Panel System - Tile Installation

## Assembly Instructions



Assemble units as described herein only. To do otherwise may result in instability. All screws, nuts and bolts must be tightened securely and must be checked periodically after assembly. Failure to assemble properly, or to secure parts may result in assembly failure and personal injury.



Rare Earth Magnets used with this product. The magnets can be harmful to pacemaker wearers and others with medical devices. **Pacemaker wearers should stay at least one foot away from the steel tiles.**

### Slat Wall Tile Installation

**Note:** Slat wall tiles install to Unite frames above standard segmented tiles utilizing an integral H-channel at the bottom of the tile. The H-channel at the bottom captures the top of the segmented tile it rests on. Above each slat wall tile another segmented tile must be installed using a segmented H-trim channel which is placed between them to hold the slat wall tile in place from above.

1. In a typical slat wall tile installation, first install a "bottom trim channel" into the panel frame "vertical posts". Position the bottom trim channel as illustrated, and hook the top lip into the bottom P-slot notches in the vertical posts. Push trim channel down into the slots to secure (Figure 3).

**Note:** Standard tiles have vertical tile stiffeners installed to the back side. At one end of each stiffener the tabs are extended out, and at the other end they are not. The end with the tabs extended is the top of the tile.

2. Position the standard tile such that the "open tabs" at the top of the vertical tile stiffeners are at the top of the panel (Figure 3).
3. Hold the tile up, then center and nest the bottom of the tile into the bottom trim channel. Push the top of the tile against the frame and lift such that the tabs of the stiffeners enter the P-slots. Push in and down gently to allow tile bottom to nest down into the bottom trim channel (Figure 3).

**Note:** Unite tiles do not hang from the stiffener tabs. Support of the tiles is provided by the bottom trim channel or the segmented H-trim channel. The tabs simply keep the tile from tipping away from the frame.

4. Next, position the slat wall tile as illustrated, with the integral H-channel facing down, and set onto the top of the lower segmented panel. Hold the slat wall tile from tipping away and set a segmented H-shape trim channel onto the top of the slat wall tile, such that the wide flange of the channel is behind the tile as illustrated. Ensure the tabs on the back side of the slat wall tile nest into the "P" slots on the vertical post. Finally, install a segmented tile above the H-shape trim as illustrated (Figure 3).

**Note:** Eight inch high segmented panels will have hook and loop pads instead of stiffener tabs for securing to vertical posts.

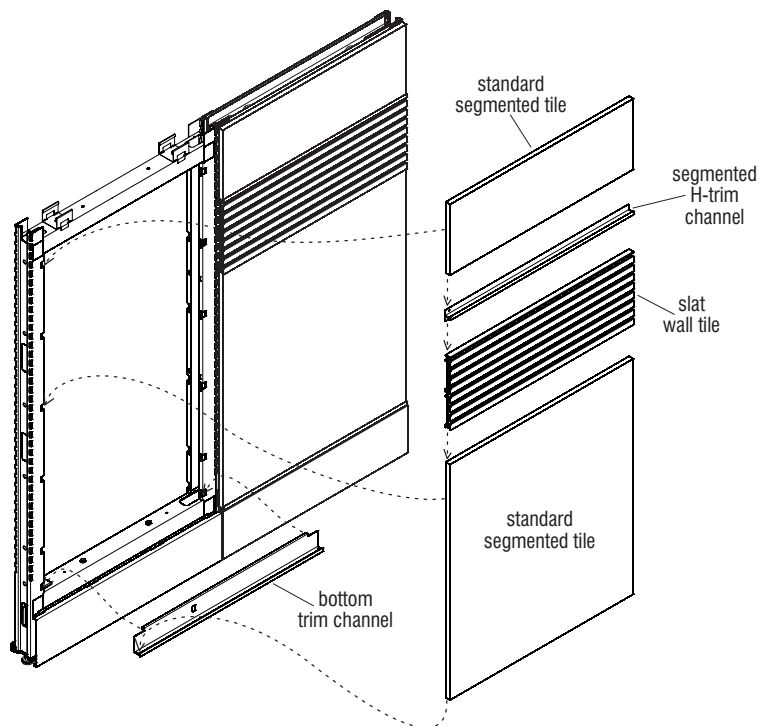

Figure 3 - Slat Wall Tile Installation





Rare Earth Magnets used with this product. The magnets can be harmful to pacemaker wearers and others with medical devices. **Pacemaker wearers should stay at least one foot away from the steel tiles.**



Assemble units as described herein only. To do otherwise may result in instability. All screws, nuts and bolts must be tightened securely and must be checked periodically after assembly. Failure to assemble properly, or to secure parts may result in assembly failure and personal injury.

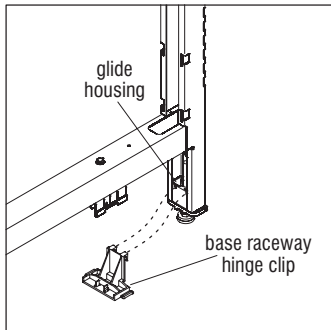

Detail A

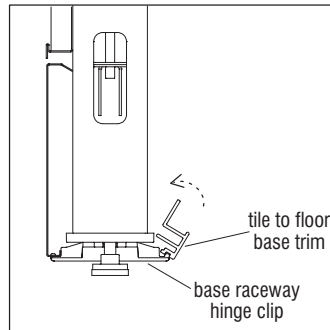

Detail B

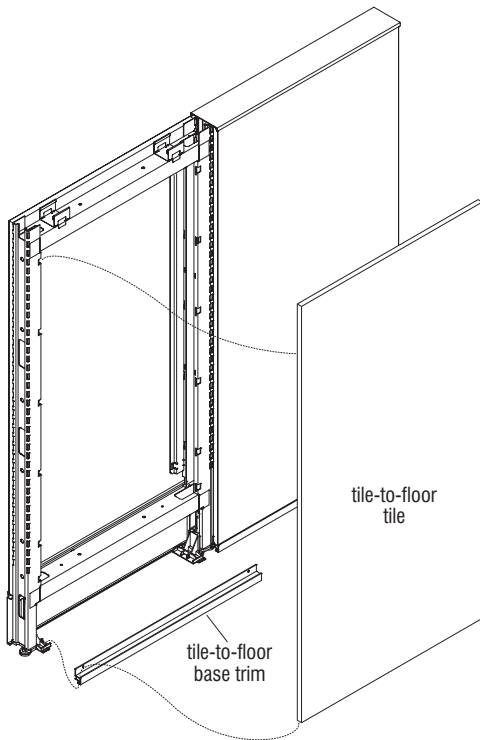

Figure 4 - Tile to Floor Tile Installation

### Tile-To-Floor Tile Installation

**Note:** Unite tile-to-floor tiles may have surface materials applied such as fabric, painted steel or a markerboard surface, and they attach to panel frames designed with no base raceways and no lifted raceways. Standard segmented tiles are split at beltways and are separated by “segmented H-trim channels”. The instructions to follow cover a typical full-height tile to floor panel.

**Important:** If tile-to-floor tiles are painted steel or a markerboard surface, see “Steel Tile and Steel Markerboard Tile Installation” instructions on page 39 and take notice of rare earth magnet warning.

1. If not previously installed to panel frame, install two base raceway hinge clips to the proper location at the panel glide housings (Detail A).
  2. Install a tile-to-floor base trim (extruded aluminum) to the bottom of the panel frame by positioning the bottom notch of the base trim onto the bumps of each base raceway hinge clip, then rotate vertically into place until the two horizontal flanges snap onto the flange of both glide housings (Detail B & Figure 4).
- Note:** Tile-to-floor tiles have vertical tile stiffeners installed to the back side. At one end of each stiffener the tabs are extended out, and at the other end they are not. The end with the tabs extended is the top of the tile.
3. Position the tile-to-floor tile such that the “open tabs” at the top of the vertical tile stiffeners are at the top of the panel (Figure 4).

4. Hold the tile up, then center and nest the bottom of the tile into the channel of the tile-to-floor base trim. Push the top of the tile against the frame and lift such that the tabs of the stiffeners enter the P-slots. Push in and down gently to allow tile bottom to nest down into the bottom channel of the tile-to-floor base trim (Figure 4).

**Note:** Unite tiles do not hang from the stiffener tabs. Support of the tiles is provided by the bottom trim channel, or the segmented H-trim channel. The tabs simply keep the tile from tipping away from the frame.

## ■ Unite® Panel System - Tile Installation

Assembly Instructions



Assemble units as described herein only. To do otherwise may result in instability. All screws, nuts and bolts must be tightened securely and must be checked periodically after assembly. Failure to assemble properly, or to secure parts may result in assembly failure and personal injury.



Rare Earth Magnets used with this product. The magnets can be harmful to pacemaker wearers and others with medical devices. **Pacemaker wearers should stay at least one foot away from the steel tiles.**

### 72" Panel Frame - Split Tile Installation

**Note:** Unite 72" panel frames, when fully assembled incorporate two 36" wide tiles mounted to frame components with a light shield at the center of the 72" panel frame. Beltway-height electrical components must be installed prior to light shield installation.

1. At the location of the 72" panel frame where a standard height, or lifted-height tile will rest, install a "bottom trim channel" (72" length) into the "vertical posts". Position the bottom trim channel as illustrated, and hook the top lip into the bottom P-slot notches in the vertical posts while also hooking the top lip over the 72" panel frame support bracket (Figure 5).

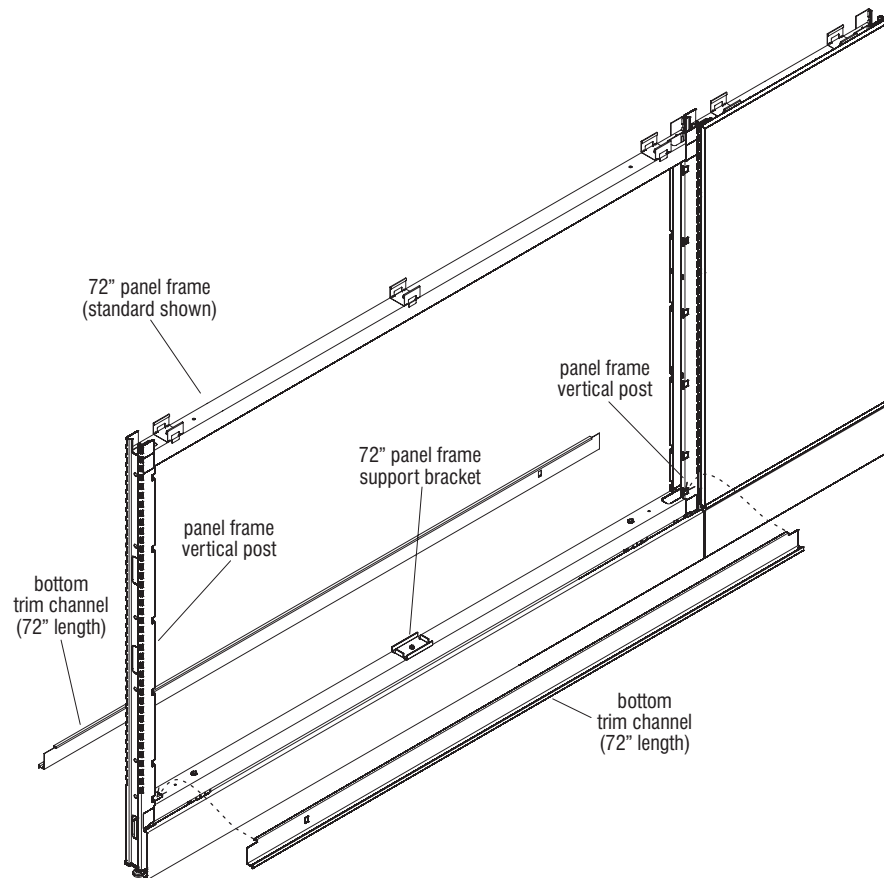

**Figure 5 - 72" Panel Frame, Bottom Trim Channel**



Rare Earth Magnets used with this product. The magnets can be harmful to pacemaker wearers and others with medical devices. **Pacemaker wearers should stay at least one foot away from the steel tiles.**



Assemble units as described herein only. To do otherwise may result in instability. All screws, nuts and bolts must be tightened securely and must be checked periodically after assembly. Failure to assemble properly, or to secure parts may result in assembly failure and personal injury.

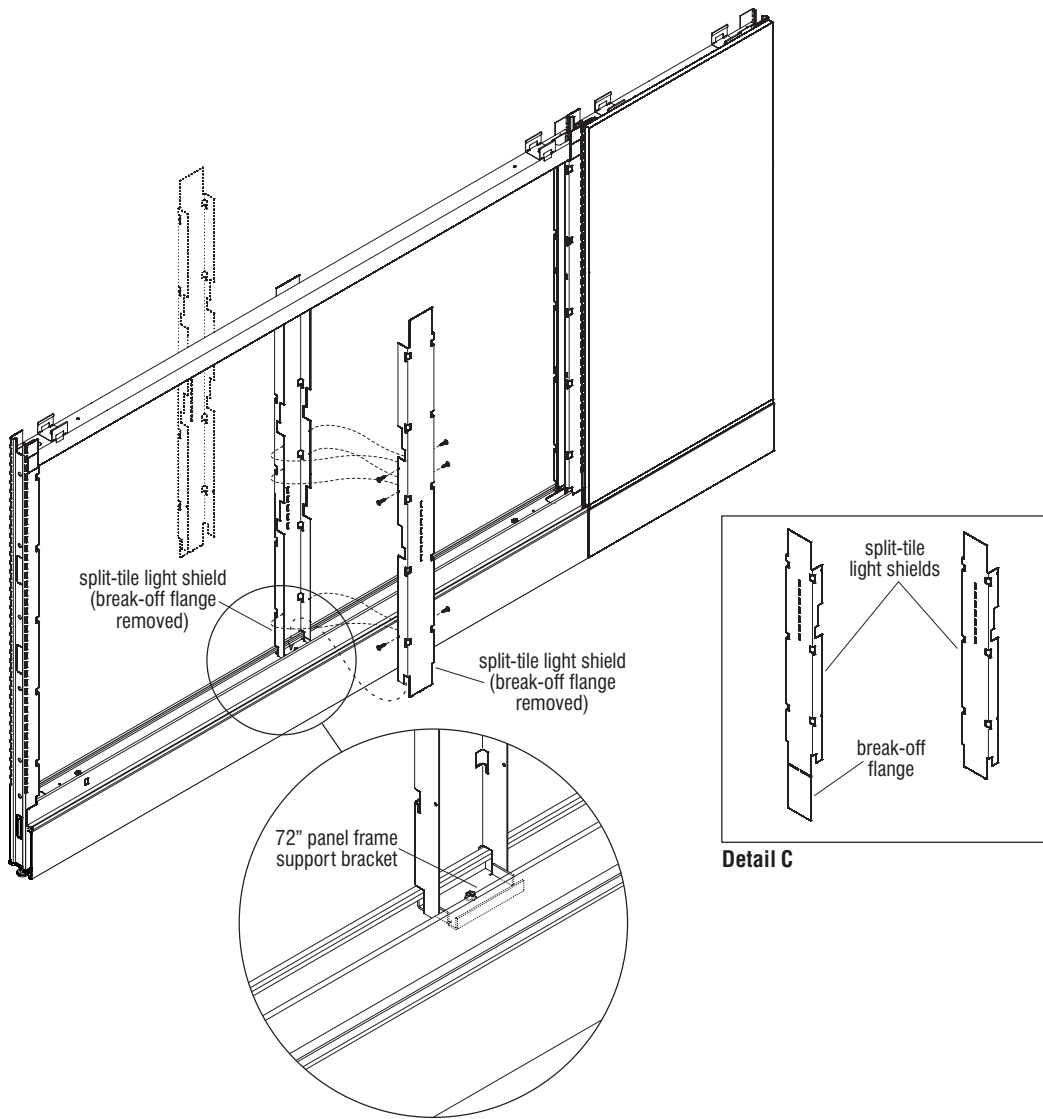

Figure 6 - 72" Panel Frame, Split-Tile Light Shield

**Note:** Split-tile light shields have a break-off flange located at the bottom (Detail C). This flange must be removed for use with standard, or lifted base split tile applications, but the tile must be kept in tact for tile-to-floor panel frame installations.

2. For each 72" panel frame (standard, or lifted base), take two split-tile light shields and remove the lower break-off flange from each by bending back-and-forth along the thin tabs until it breaks, then discard the excess bottom flange (Detail C).
3. Center and set the bottom edge of each light shield into the outside, top of the bottom trim channel as illustrated at each side of the panel frame. Use the panel frame support bracket to align both light shields directly on center. Make certain that the light shield is positioned to the outside of the trim at both sides, such that the notches in the bottom of the light shield capture the top of the bottom trim channel (Figure 6).
4. Measure horizontally at the top of the split-tile panel frame and mark the exact center, then center the pair of mated light shields and use a spirit level to assure the pair is exactly vertical. Finally, align the mounting holes at both sides and secure using a minimum of two #8 x 3/4" Phillips pan head (38.12.5048) at each side (Figure 6).

**Caution:** It is very important that the pair of light shields be installed perfectly centered and vertical. This is necessary for correct tile alignment

## ■ Unite® Panel System - Tile Installation

Assembly Instructions



Assemble units as described herein only. To do otherwise may result in instability. All screws, nuts and bolts must be tightened securely and must be checked periodically after assembly. Failure to assemble properly, or to secure parts may result in assembly failure and personal injury.



Rare Earth Magnets used with this product. The magnets can be harmful to pacemaker wearers and others with medical devices. **Pacemaker wearers should stay at least one foot away from the steel tiles.**

### 72" Panel Frame - Split Tile Installation

**Note:** Standard fabric (full-height & segmented) tiles have vertical tile stiffeners installed to the back side. At one end of each stiffener, the tabs are extended out, and at the other end they are not. The end with the tabs extended is the top of the tile.

**Important:** If tiles being installed have a painted steel or markerboard surface, see "Steel Tile and Steel Markerboard Tile Installation" instructions on page 39 and take notice of rare earth magnet warning.

1. Position the 36" panel tile such that the "open tabs" at the top of the vertical tile stiffeners are at the top of the panel (Figure 7).
2. Hold the tile up, then center and nest the bottom of the tile into the bottom trim channel. Push the top of the tile against the frame and lift such that the tabs at the top of the stiffeners enter the P-slots. Push in and down gently to allow tile bottom to nest down into the bottom trim channel (Figure 7).

**Note:** Unite tiles do not hang from the stiffener tabs. Support of the tiles is provided by the bottom trim channel, or the segmented H-trim channel. The tabs simply keep the tile from tipping away from the frame.

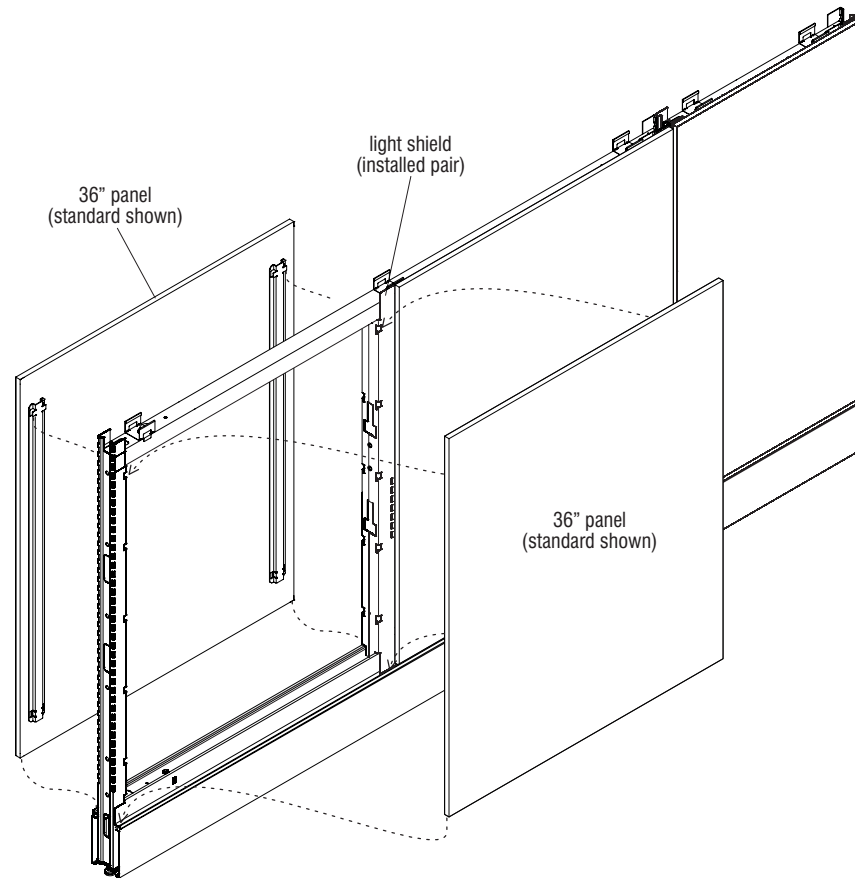

Figure 7 - 72" Panel Frame, Split-Tile Installation



Rare Earth Magnets used with this product. The magnets can be harmful to pacemaker wearers and others with medical devices. **Pacemaker wearers should stay at least one foot away from the steel tiles.**



Assemble units as described herein only. To do otherwise may result in instability. All screws, nuts and bolts must be tightened securely and must be checked periodically after assembly. Failure to assemble properly, or to secure parts may result in assembly failure and personal injury.

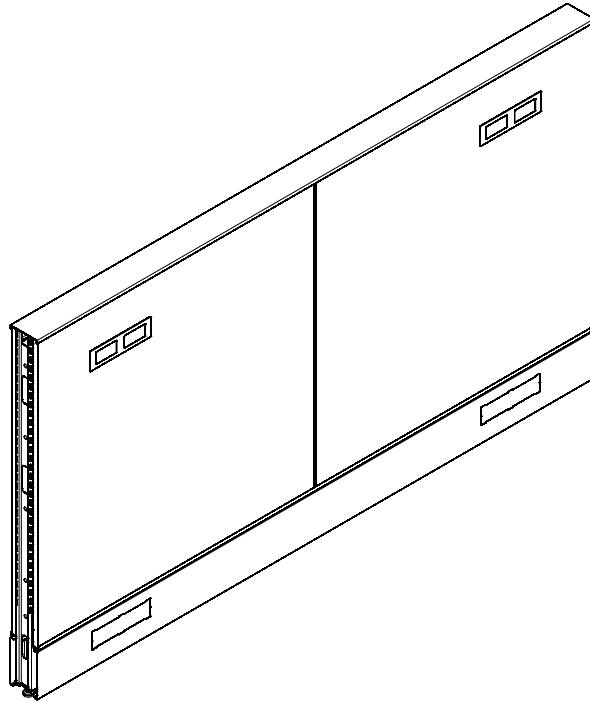

**Figure 8 - 72" Panel Frame, Beltway-Height Power**

3. If beltway-height power is installed in a 72" panel frame, install the tile with the left-hand cut-out to the left side of the frame and the right-hand cut-out to the right side (Figure 8).
4. If a 72" split-tile panel is to have segmented tiles, slat wall tiles, or if installation is to be tile-to-floor tile installation, see pages 40 through 41 (Figures & Details 3 through 4).

## ■ Unite® Panel System - Trim Installation

Assembly Instructions



Assemble units as described herein only. To do otherwise may result in instability. All screws, nuts and bolts must be tightened securely and must be checked periodically after assembly. Failure to assemble properly, or to secure parts may result in assembly failure and personal injury.

### Base Raceway Cover Installation

1. If not previously installed to panel frame, install two raceway mounting brackets with  $\frac{3}{8}$ -16 x  $1\frac{1}{4}$ " bolts provided (Figure 9).
2. At the bottom of the panel frame which will receive the base raceway cover, install two plastic base raceway hinge clips by nesting the hooks of the clips into the two slots in glide housing top, then press down to snap hinge clip into place (Figure 9).
3. Install the base raceway cover to the panel by first aligning the slots at the bottom of the raceway cover with the bumps at the bottom of the base raceway hinge clips. After both ends are engaged to hinge clips at the bottom, rotate the top of the base raceway cover up toward the frame and snap the top onto the rigid wireway mounting bracket to secure (Figure 9).

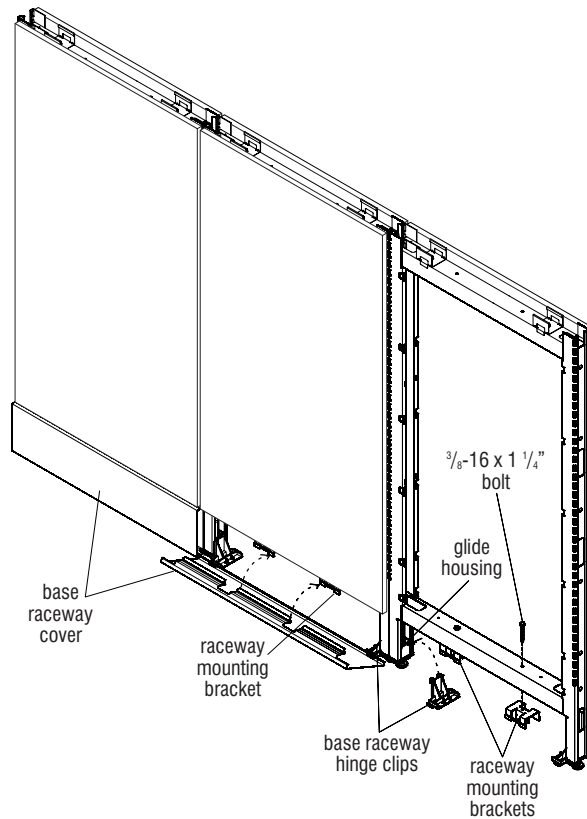

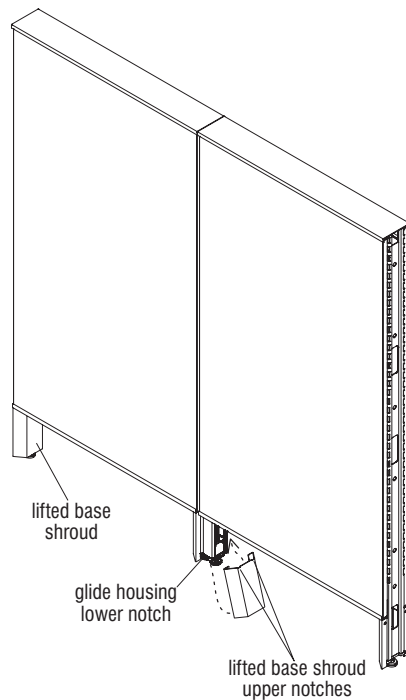

Figure 9 - Base Raceway Trim Installation



Assemble units as described herein only. To do otherwise may result in instability. All screws, nuts and bolts must be tightened securely and must be checked periodically after assembly. Failure to assemble properly, or to secure parts may result in assembly failure and personal injury.

**CAUTION**



**Figure 10 - Lifted Base Shroud Installation**

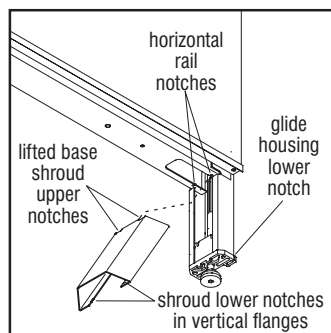

**Detail D**

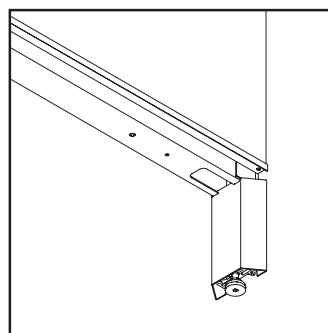

**Detail E**

**Lifted Base Shroud Installation**

**Note:** The lifted base shroud has a top and bottom, and the shroud must be oriented correctly at time of installation. The top of the shroud has two notches cut out of the longer, inside-face of the shroud, and the bottom of the shroud has notches in the smaller vertical flanges (Figure 10 & Detail D).

1. Position the lifted base shroud with the upper notches facing up, and from under the lower horizontal rail of the panel frame, turn the shroud at an angle and insert the notches of the shroud into the horizontal rail notches (Detail D). Next, rotate the bottom of the shroud down to the glide housing of the panel frame, then strike the bottom of the shroud with the palm of your hand or a rubber mallet to snap the shroud into place (Figure 10, Details D & E).

**Note:** Shroud notches in the bottom vertical flanges snap into the glide housing lower notches to hold it in place. The shroud can be moved up and down slightly when it is installed correctly into place.

# Unite® Panel System - Trim Installation

Assembly Instructions



Assemble units as described herein only. To do otherwise may result in instability. All screws, nuts and bolts must be tightened securely and must be checked periodically after assembly. Failure to assemble properly, or to secure parts may result in assembly failure and personal injury.

## Vertical Intersection Trim Installation

**Note:** Vertical intersection trim (in-line intersection, 90° corner, & 120° corner) must be installed after intersection connection has been completely secured, and installed to panel frames prior to installing any top caps, or end-of-run trim.

**IMPORTANT:** Refer to page 3 for usage overview on connector block with spacer plate (Detail A).

1. Orient vertical trim correctly, with top facing up. A paint line hanging hole on the back flange of each trim should be at the bottom when properly positioned. The inner mounting flanges have hang-on tabs that hook onto the top of each connector block and hold the trim in place (Figures 11, 12, 13 & Details F, G & H).
2. Locate the hang-on tabs on the back of the trim and align the tabs just above the corners on each connector block. Press the trim into position onto the connector blocks and tap the trim down to firmly seat in place. Take care to assure that hang-on tabs have captured all connector blocks at the intersection (Figures 11, 12, 13 & Details F, G & H)

**Note:** For equal-height intersections, one full-height vertical trim piece is required (Figures 11, 12 & 13). For height-change intersections, two stacked trim pieces are required to complete the intersection (Figures 14 & 15). At height-change intersections, the lower trim must install first and the upper trim stacks, then clips on above it.

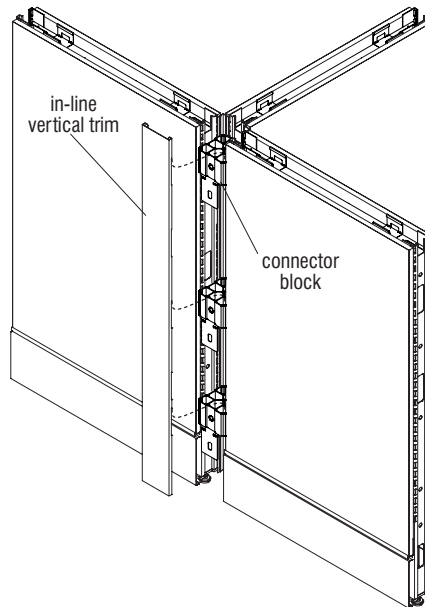
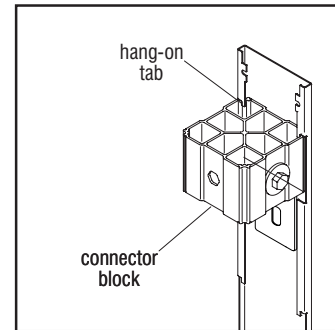

Figure 11- In-Line Intersection Vertical Trim



Detail F

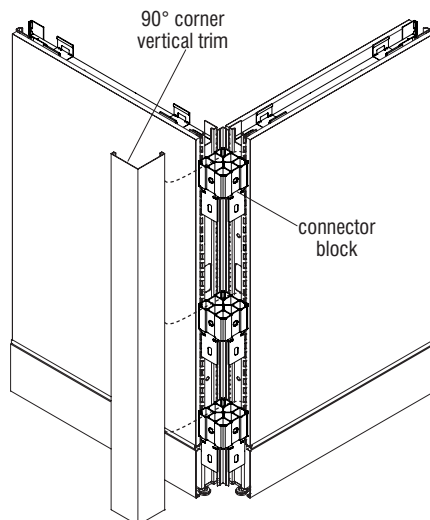
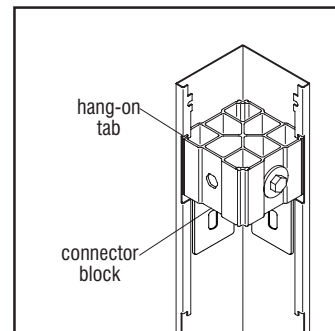

Figure 12 - 90° Corner Vertical Trim



Detail G





Assemble units as described herein only. To do otherwise may result in instability. All screws, nuts and bolts must be tightened securely and must be checked periodically after assembly. Failure to assemble properly, or to secure parts may result in assembly failure and personal injury.

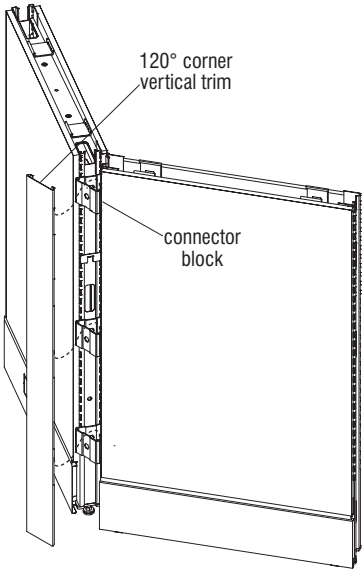
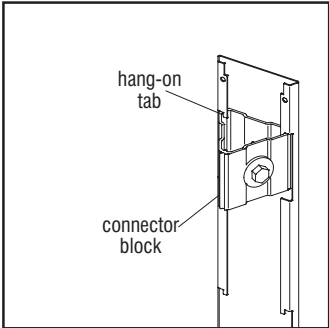

Figure 13 - 120° Corner Vertical Trim



Detail H

## ■ Unite® Panel System - Trim Installation

### Assembly Instructions



Assemble units as described herein only. To do otherwise may result in instability. All screws, nuts and bolts must be tightened securely and must be checked periodically after assembly. Failure to assemble properly, or to secure parts may result in assembly failure and personal injury.

### End-of-Run Height Change Trim Installation

**Note:** Vertical height change “snap-on” trim (in-line, 90° & 120°) is installed different than “hang-on” intersection/end-of-run trim. Height change trim snaps onto “end-of-run trim clips” and has a specific top and bottom, so requires correct orientation to attach properly.

1. Install a vertical splice clip into the top of the vertical 90° or in-line corner intersection trim (Figures 14 & 15).

**Note:** Vertical splice clips help align mating vertical trim. The splice clip is provided for various in-line and 90° connections. For in-line connections (Figure 15), snap off one-half of the splice clip at the notch location and discard the unused section.

2. Orient the appropriate “end-of-run height change trim” with the top up, so it aligns properly with the installed end-of-run trim clip. Correctly positioned, the longer tabs of the trim will be to the top, and the smaller tabs with paint-hanging hole will be at the bottom. The bottom of the upper tabs will rest on the top edge of the end-of-run trim clip (Figures 14 & 15).
3. Hook one side of the end-of-run height change trim onto the end-of-run trim clip. Rotate the hooked trim towards the un-clipped side, up against the trim clip and snap the trim into place by striking the loose side with a rubber mallet or the palm of your hand. Ensure that the clip(s) are fully engaged to prevent trim from falling off (Figures 14 & 15).
4. Finally, orient the “dead end intersection cap” as illustrated and insert the tabs of the cap into the narrow slots in the top cap. Mate the dead-end intersection

cap into the top of the end-of-run height change trim and snap the top cap into place at the top of the panel frame (Figures 14 & 15).

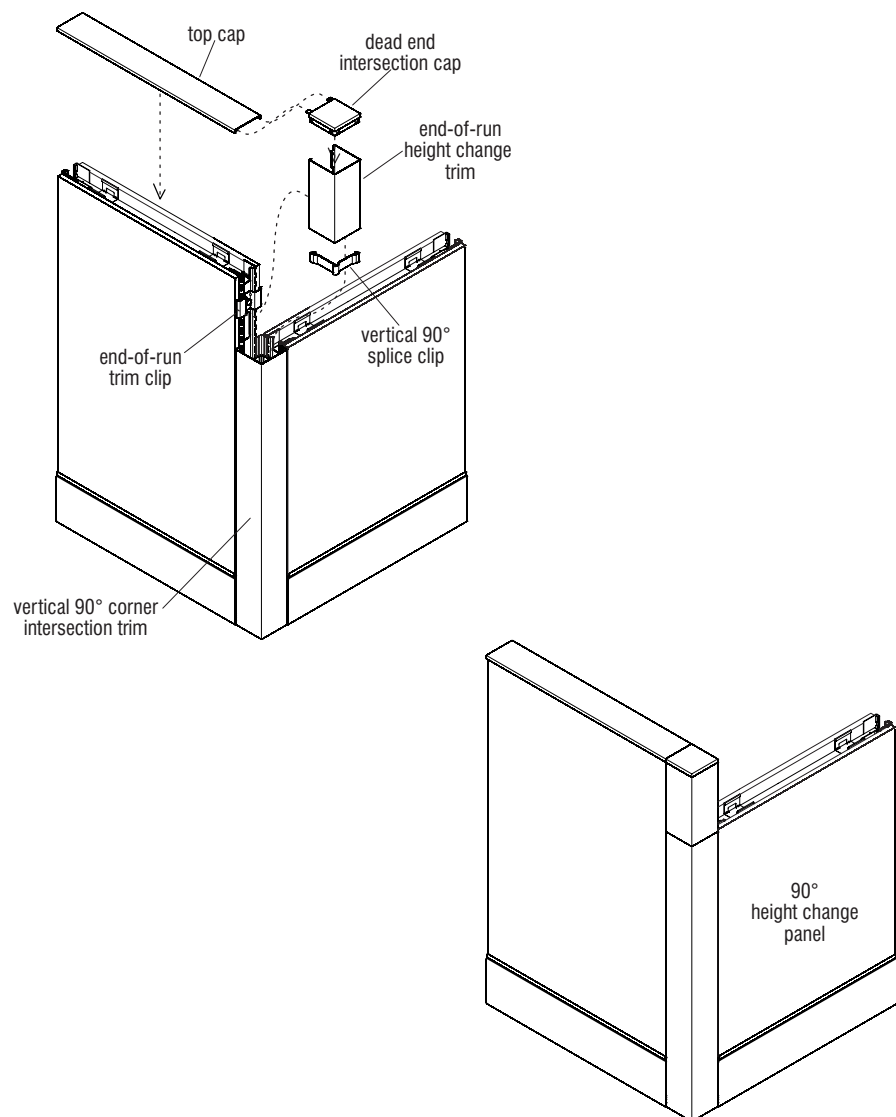



Figure 14 - End-of-Run 90° Height Change Vertical Trim

  
**CAUTION**

Assemble units as described herein only. To do otherwise may result in instability. All screws, nuts and bolts must be tightened securely and must be checked periodically after assembly. Failure to assemble properly, or to secure parts may result in assembly failure and personal injury.

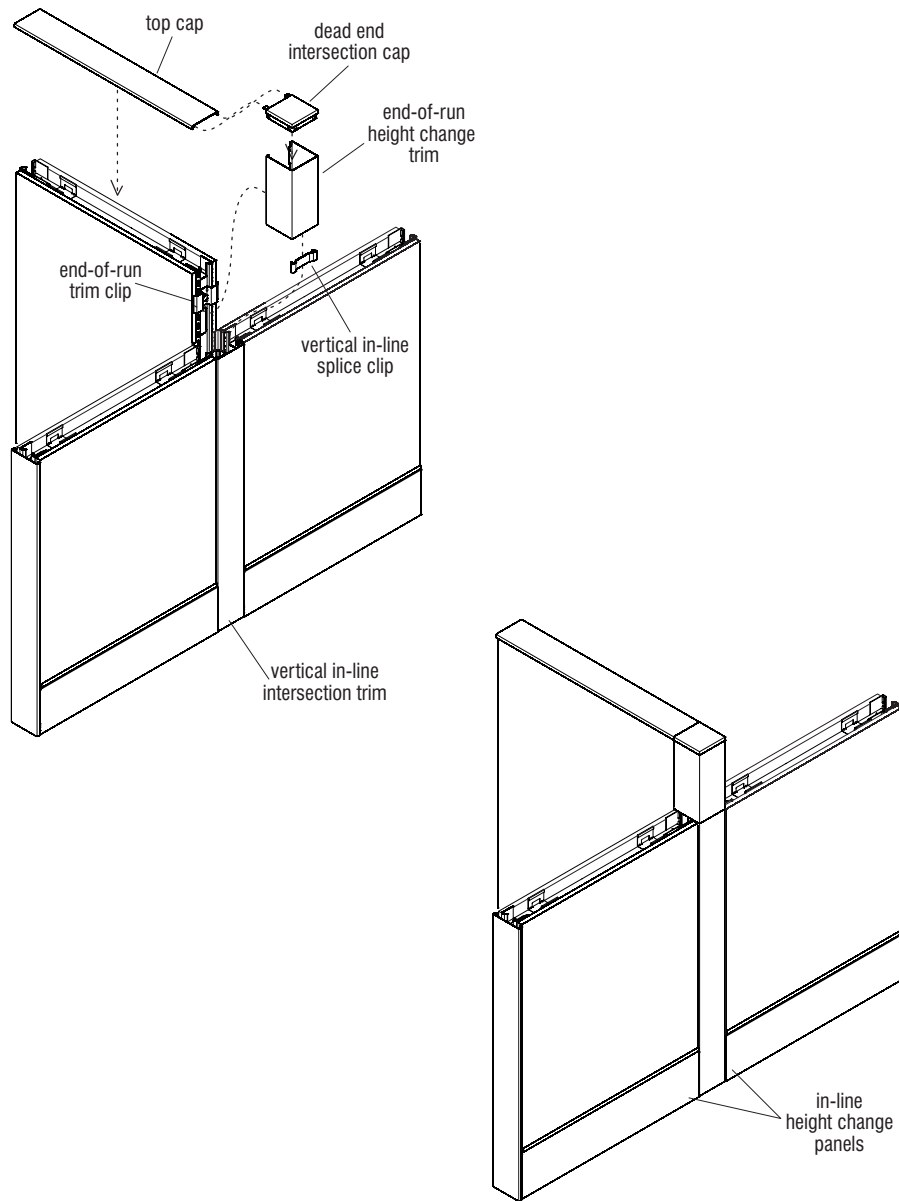

Figure 15 - End-of-Run In-Line Height Change Vertical Trim

## ■ Unite® Panel System - Trim Installation

Assembly Instructions



Assemble units as described herein only. To do otherwise may result in instability. All screws, nuts and bolts must be tightened securely and must be checked periodically after assembly. Failure to assemble properly, or to secure parts may result in assembly failure and personal injury.

### End-of-Run Height Change Trim Installation

**Note:** Vertical height change “snap-on” trim (120°) is installed different than “hang-on” intersection/end-of-run trim. Height change trim snaps onto “end-of-run trim clips” and has a specific top and bottom, so requires correct orientation to attach properly.

1. Orient the “120° end-of-run height change trim” with the top up, so it aligns properly with the installed end-of-run trim clip. Correctly positioned, the longer tabs of the trim will be to the top, and the smaller tabs with paint-hanging hole will be at the bottom. The bottom of the upper tabs will rest on the top edge of the end-of-run trim clip (Figure 16).
3. Hook one side of the 120° end-of-run height change trim onto the end-of-run trim clip. Rotate the hooked trim towards the un-clipped side, up against the trim clip and snap the trim into place by striking at the side opposite the loose side, toward the loose side with a rubber mallet or the palm of your hand. Ensure that the clip(s) are fully engaged to prevent trim from falling off (Figure 16).
4. Finally, orient the “dead end intersection cap” as illustrated and insert the tabs of the cap into the narrow slots in the top cap. Mate the dead-end intersection cap into the top of the end-of-run height change trim and snap the top cap into place at the top of the panel frame (Figure 16).

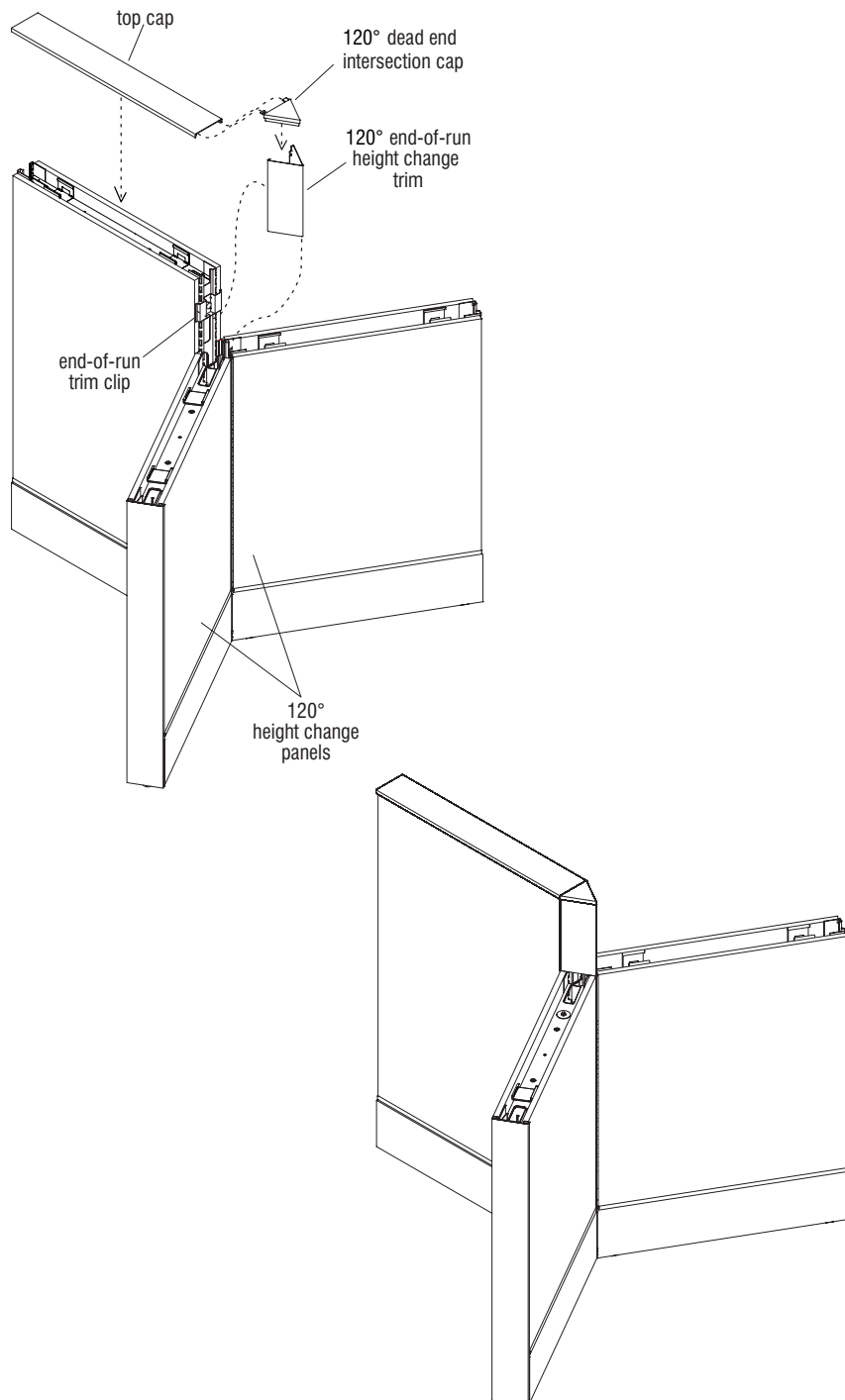



Figure 16 - End-of-Run 120° Height Change Vertical Trim



Assemble units as described herein only. To do otherwise may result in instability. All screws, nuts and bolts must be tightened securely and must be checked periodically after assembly. Failure to assemble properly, or to secure parts may result in assembly failure and personal injury.

**Top Cap Installation**

**Note:** Top caps are installed to the top of panel frames. They connect together using horizontal splice plates in-line. Top caps utilize metal intersection caps at intersections. Top caps secure the top tile when installed and are held in place by spring clips.

1. Top cap installation should begin at an intersection utilizing the appropriate metal intersection cap (see page 54, Detail J - Intersection Caps), by first connecting top caps to the intersection cap. Attach by inserting the tabs of the intersection cap into the narrow slots on the top cap as illustrated (Figure 17).

2. Each top cap includes one metal horizontal splice plate to align multiple top caps. Insert the splice plate into the end of the top cap and join in-line top caps together before installing to panel frames (Figure 17).

3. Set the joined top caps in place on the panel frames as you move along, but do not snap in place at this time. Repeat step 2 above, joining top caps with splice plates until you reach either an end of run, or a change-of-height condition.

**Note:** Metal end caps will be installed with vertical trim after top caps are installed.

4. After all top caps and intersection caps are in place press down along the top cap at all spring clip locations to secure top caps in place (Figure 17).

5. To remove top cap from panel frame, first position both hands at the top/side of the top cap at the spring clip locations. Use hands to pull the top cap toward one side of the panel frame. This action will compress one side of the spring clips. While compressing to one side, rotate the top cap up to release the spring clips and lift top cap up to remove (Detail I).

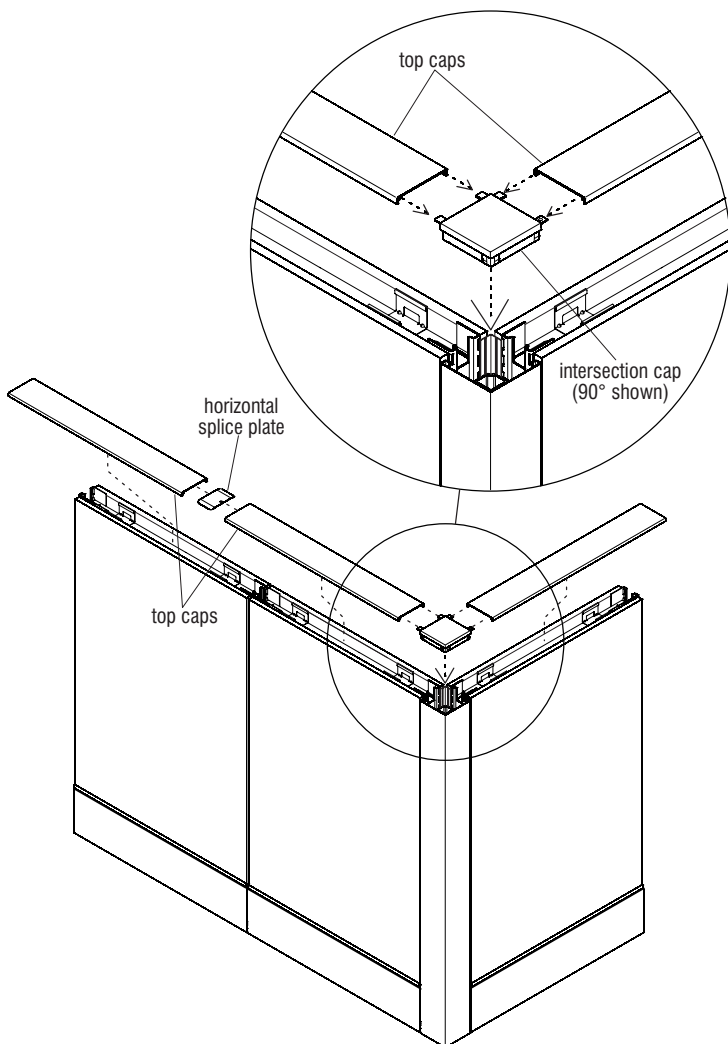
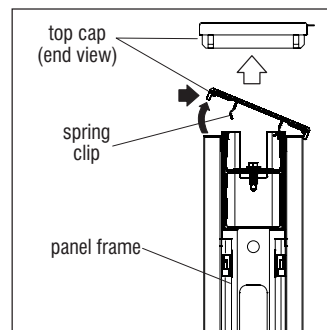

Figure 17 - Base Raceway Trim Installation



Detail I

## ■ Unite® Panel System - Trim Installation

### Assembly Instructions



Assemble units as described herein only. To do otherwise may result in instability. All screws, nuts and bolts must be tightened securely and must be checked periodically after assembly. Failure to assemble properly, or to secure parts may result in assembly failure and personal injury.

### Vertical End-of-Run & Height-Change Vertical Trim Installation

**Note:** End-of-Run vertical & end-of-run height change vertical "snap-on" trim is the last trim to be installed to panel frames. Vertical height change "snap-on" trim is installed differently than "hang-on" intersection/end-of-run trim. Height change trim snaps onto "end-of-run trim clips" and has a specific top and bottom, so requires correct orientation to attach properly.

1. Begin installation at the end of the panel with the longer, end-of-run vertical trim. The metal end cap should be snapped into position at this time. Insert metal end cap vertically into the top of the end-of-run vertical trim, then position the trim and cap such that the horizontal tabs of end cap slide horizontally into the slots in the top cap (Figure 18).
2. Hook one side of the end-of-run vertical trim onto the end-of-run trim clips. Rotate the hooked trim towards the un-clipped side, up against the trim clips and snap the trim into place by striking the loose side with a rubber mallet or the palm of your hand. Ensure that the clips are fully engaged to prevent trim from falling off. Make sure the height change top cap is snapped into place (Figure 18).
3. Next, orient the appropriate "height change vertical in-line trim" with the top up, so it aligns properly with the installed end-of-run trim clip. Correctly positioned, the longer tabs of the trim will be to the top, and the smaller tabs with paint-hanging hole will be at the bottom. The bottom of the upper tabs will rest on the top edge of the end-of-run trim clip (Figure 18).

4. Hook one side of the end-of-run height change trim onto the end-of-run trim clip. Rotate the hooked trim towards the un-clipped side, up against the trim clip and snap the trim into place by striking the loose side with a rubber mallet or the palm of your hand. Ensure that the clip(s) are fully engaged to prevent trim from falling off (Figure 18).
5. Finally, orient the "metal end cap" as illustrated and insert the tabs of the cap into the narrow slots in the top cap. Mate the dead-end intersection cap into the top of the end-of-run height change trim and snap the top cap into place at the top of the panel frame (Figure 18).

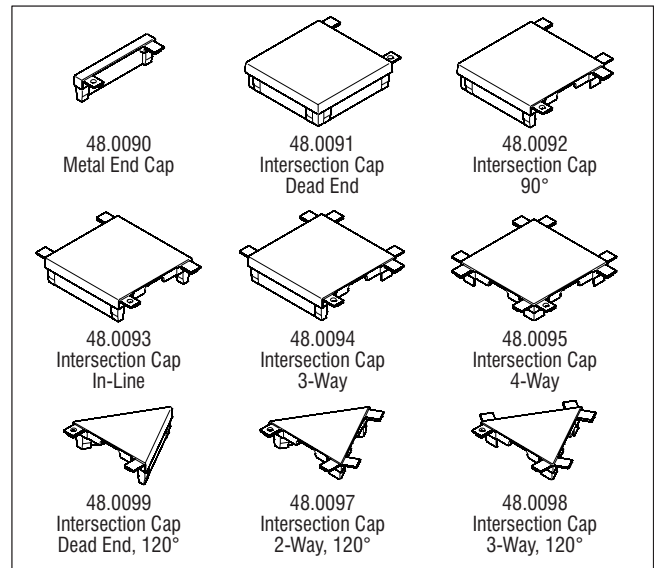

Detail J - Intersection Caps

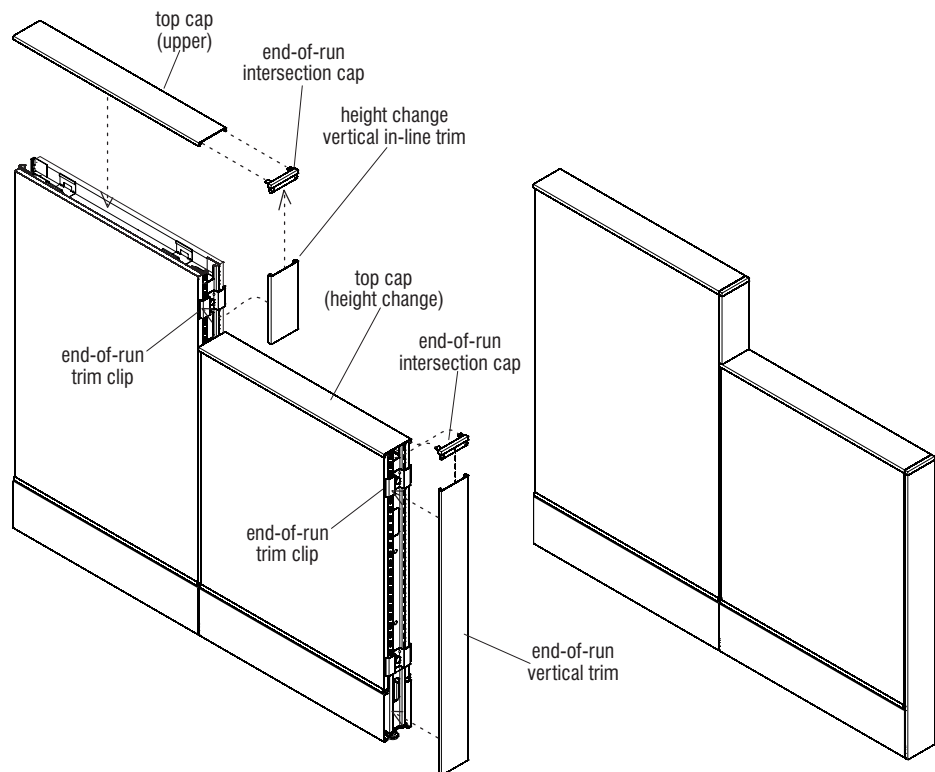
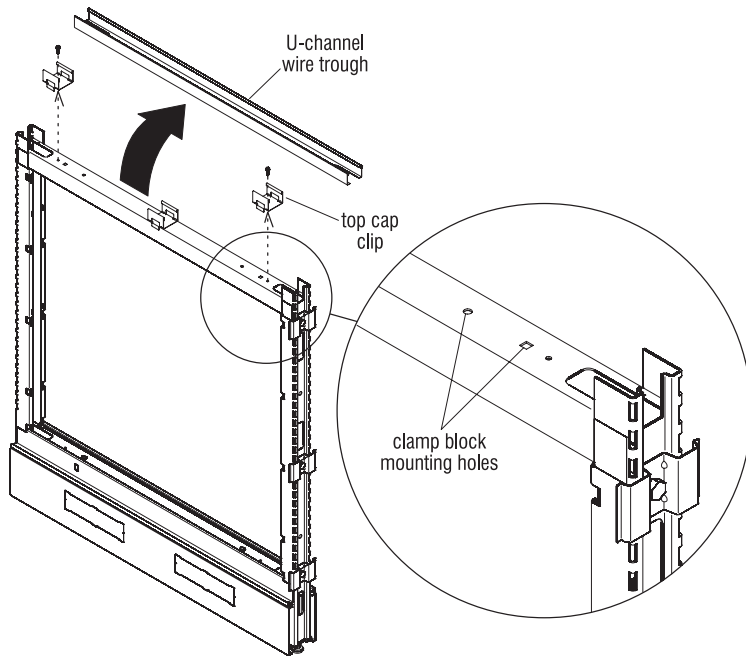

Figure 18 - Vertical End of Run & Height-Change Vertical Trim



Assemble units as described herein only. To do otherwise may result in instability. All screws, nuts and bolts must be tightened securely and must be checked periodically after assembly. Failure to assemble properly, or to secure parts may result in assembly failure and personal injury.



**Figure 1 - Wire Trough & Top Cap Clip Removal**

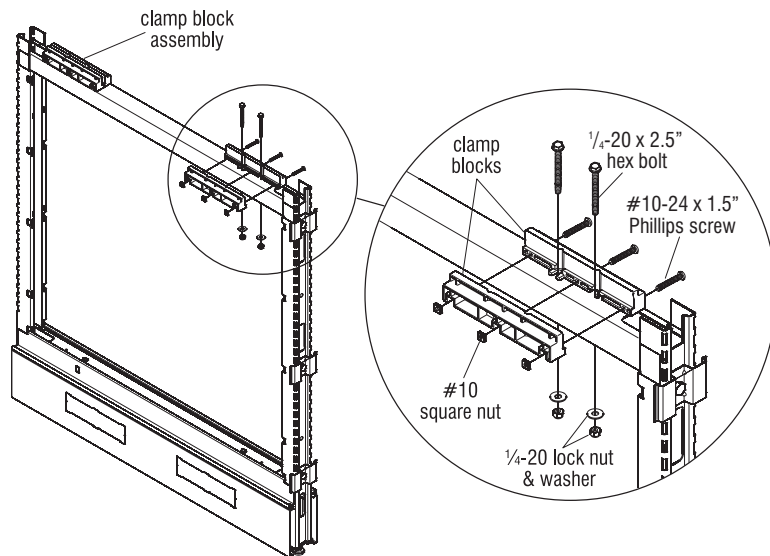

**Figure 2 - Clamp Block Installation**

### Glass Divider Installation

#### Tools Required

- level
- power drill driver
- $\frac{5}{16}$ " drill bit
- $\frac{7}{16}$ " box wrench
- #2 Phillips screw driver

**Note:** The top of your frame may contain a U-channel wire trough and two or three top cap clips, depending on date of manufacture.

1. If so equipped, unscrew and remove each U-channel wire trough and any outer top cap clips from the top of the Unite panel divider(s) which will receive glass divider(s). Any center-installed top cap clip can remain on the frame. The removed items may be discarded as they will not be used again (Figure 1).

**Note:** If the frame is an older model, the two holes for mounting the clamp blocks to each side of the frame may need to be drilled out, using a  $\frac{5}{16}$ " drill bit.

2. Loosely assemble the pair of clamp blocks as illustrated using #10-24 x 1.5" Phillips screws and square nuts. Do not tighten completely. Position the clamp-block over the indicated holes (the outer hole should be a square hole, see detail at Figure 1 and insert two  $\frac{1}{4}$ -20 x 2.5" hex head bolts down through the top of the panel frame. Install a flat washer and  $\frac{1}{4}$ -20 lock nut onto each hex bolt and tighten snug to frame. Do not tighten completely (Figure 2).
3. Repeat step two and install clamp blocks to other end of panel frame top (Figure 2).

# Unite® Panel System - Glass Dividers

Assembly Instructions



Assemble units as described herein only. To do otherwise may result in instability. All screws, nuts and bolts must be tightened securely and must be checked periodically after assembly. Failure to assemble properly, or to secure parts may result in assembly failure and personal injury.

4. Position a top cap mounting block at each end of the clamp block assembly at both clamp block assembly locations on top of the panel frame (Figure 3).
5. Carefully insert the glass divider into the clamp blocks. Center the glass on the panel from end-to-end and tighten the six Phillips screws (three screws per clamp block) to secure the glass with the clamp blocks. Do not over-tighten the screws. Over-tightening can damage the glass. Lastly, tighten the nuts below the panel frame. Do not over-tighten. Over tightening can cause damage to the block (Figure 4).

**Note:** For installation of "panel-spanning glass dividers" (one glass divider over two panel frames) see Figure 6 instructions next page.

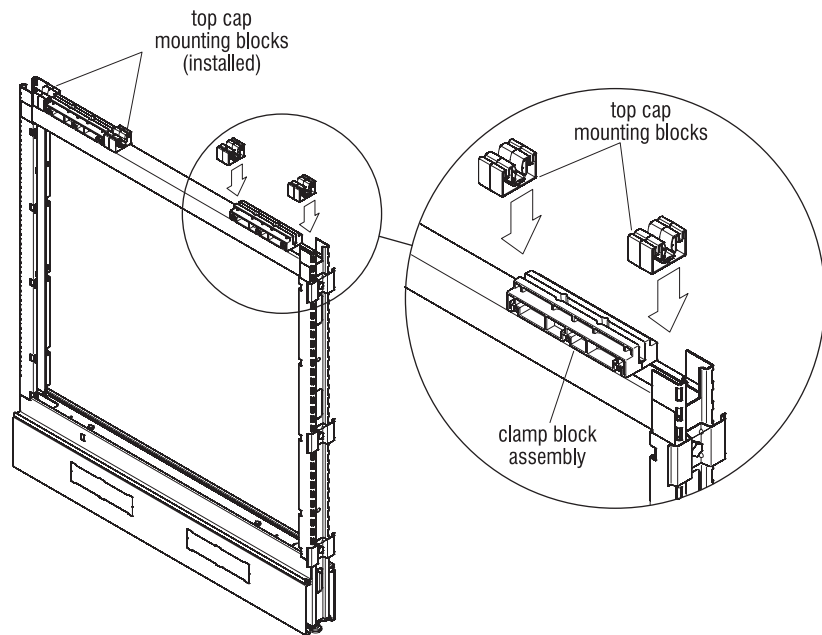

**Figure 3 - Top Cap Mounting Block Install**

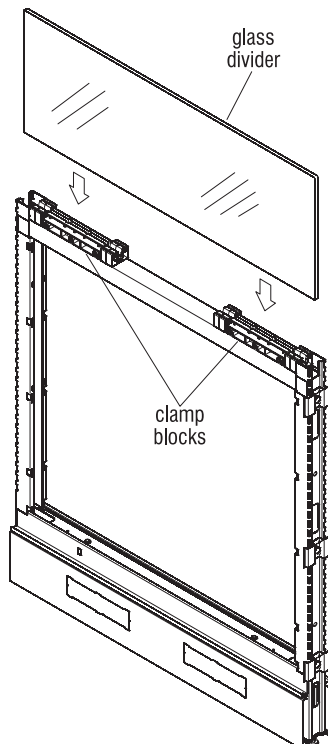

**Figure 4 - Install & Tighten Glass**





Rare Earth Magnets used with this product. The magnets can be harmful to pacemaker wearers and others with medical devices. **Pacemaker wearers should stay at least one foot away from the steel tiles.**



Assemble units as described herein only. To do otherwise may result in instability. All screws, nuts and bolts must be tightened securely and must be checked periodically after assembly. Failure to assemble properly, or to secure parts may result in assembly failure and personal injury.

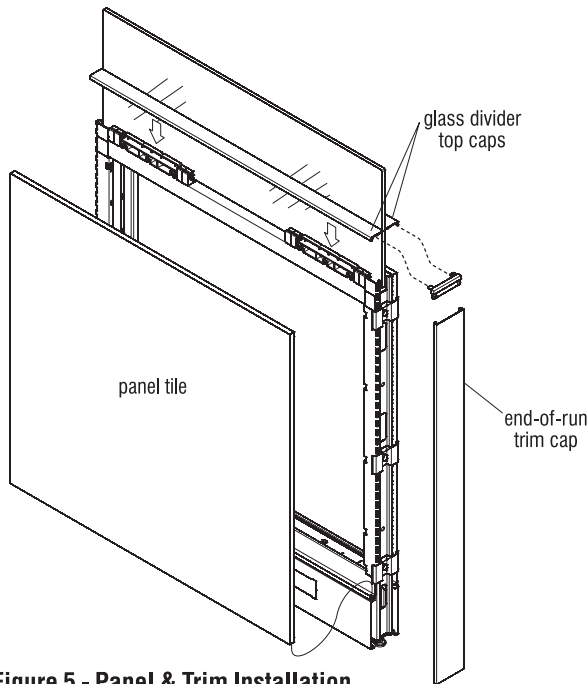

**Figure 5 - Panel & Trim Installation**

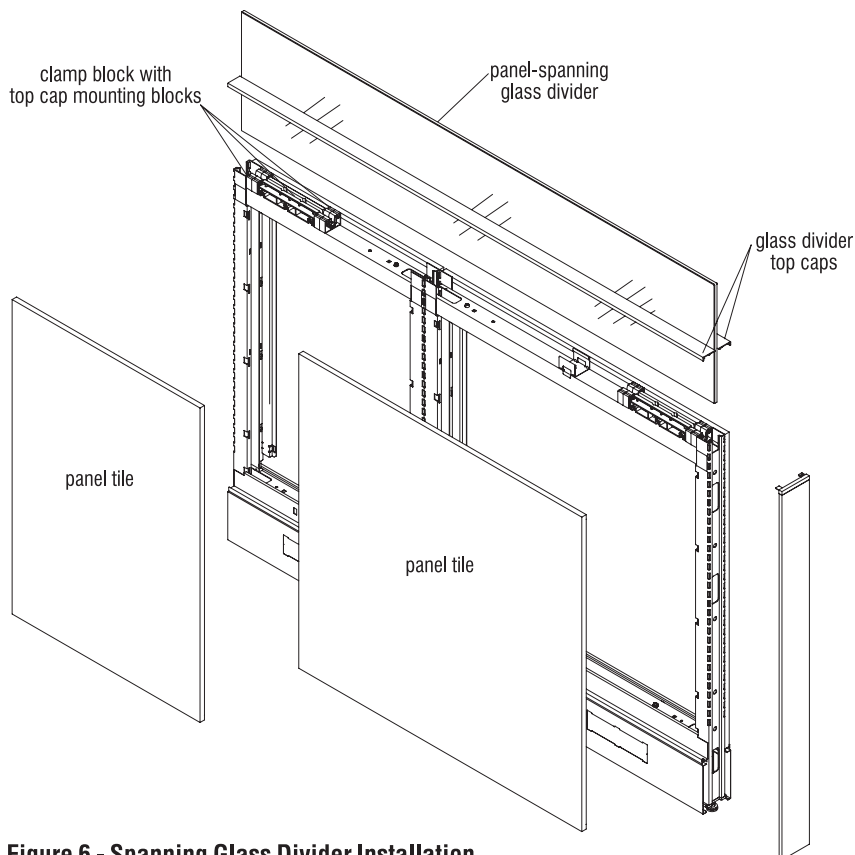

**Figure 6 - Spanning Glass Divider Installation**

6. Per “Fabric Tile-” or “Steel Tile & Steel Markerboard Tile Installation” instructions outlined on page 38 or 39, depending on the type of tile being installed, install panel tiles to divider panel frame on both sides of the frame.
7. Center the glass divider top caps over the top of the panel frame, on both sides of the glass divider as illustrated. Gently press the caps down to engage the top caps to the mounting blocks (Figure 5).
8. If necessary, shims (not supplied) may be used under the clamp block to align top of adjacent glass dividers.
9. Intersection and end-of-run trim and caps are installed as outlined in “Vertical End-of-Run & Height-Change Vertical Trim Installation” section, page 54.

**Panel-Spanning Glass Divider**

**Note:** Panel-spanning glass dividers are to be installed over adjoining panel frames as if they are installed over a single panel frame. A clamp block assembly with top cap mounting blocks is required at each end of the glass divider, but not in the center of the glass (Figure 6).



Assemble units as described herein only. To do otherwise may result in instability. All screws, nuts and bolts must be tightened securely and must be checked periodically after assembly. Failure to assemble properly, or to secure parts may result in assembly failure and personal injury.

**Worksurface Bracket & Support Overview**

The Unite Panel System offers several methods to support worksurfaces. The space-planning layout specifies the worksurfaces, bracket types, and configuration. This installation manual instructs how to assemble the brackets and worksurfaces to Unite Panels, though does not cover every combination possible. Refer to the appropriate bracket layout sections in this Worksurfaces section to install worksurfaces properly.

**Important:** Worksurfaces must be supported at both ends.

**Standard Cantilever Bracket Installation**

Brackets are left- and right-handed and may be used to support any 22", 24" & 30" deep worksurfaces regardless of edge style.

1. Locate and identify right- and left-hand cantilever brackets to be used. A right cantilever bracket is used on the right side of a worksurface as you face the panel and the left-handed bracket is at the left. The outer face of an installed cantilever bracket should appear flush with the edge of the panel surface and the mounting flange must face inward (Figure 1).
  2. Select the bracket height location based on the desired worksurface based on the desired worksurface height. Typical worksurface height is 29" from top of surface to floor. ADA height range is 28"-34".
- Example:** The typical KI worksurface thickness is 1 1/8"; therefore the installed Unite cantilever bracket should measure 27 7/8" from top of bracket to the floor.
3. To install bracket, first rotate the front of the bracket up as illustrated and insert the top,

anti-dislodge tooth into the panel module slotting at the appropriate height. Push up when the top tooth is engaged, then rotate the bottom of the bracket down, engaging all remaining bracket teeth into the slotting. Ensure that all teeth are inserted firmly, then press bracket down to fully engage all teeth. If necessary, use a rubber mallet to gently tap the top of the bracket to firmly seat the teeth. Repeat the steps above for the second cantilever bracket to be installed (Figure 1).

4. Carefully place worksurface onto installed cantilever brackets and align mounting holes of brackets to pre-drilled holes in underside of worksurface. Secure using two #12 x 3/4" screws per bracket. Take care to not over-tighten the screws (Figures 1 & 2).

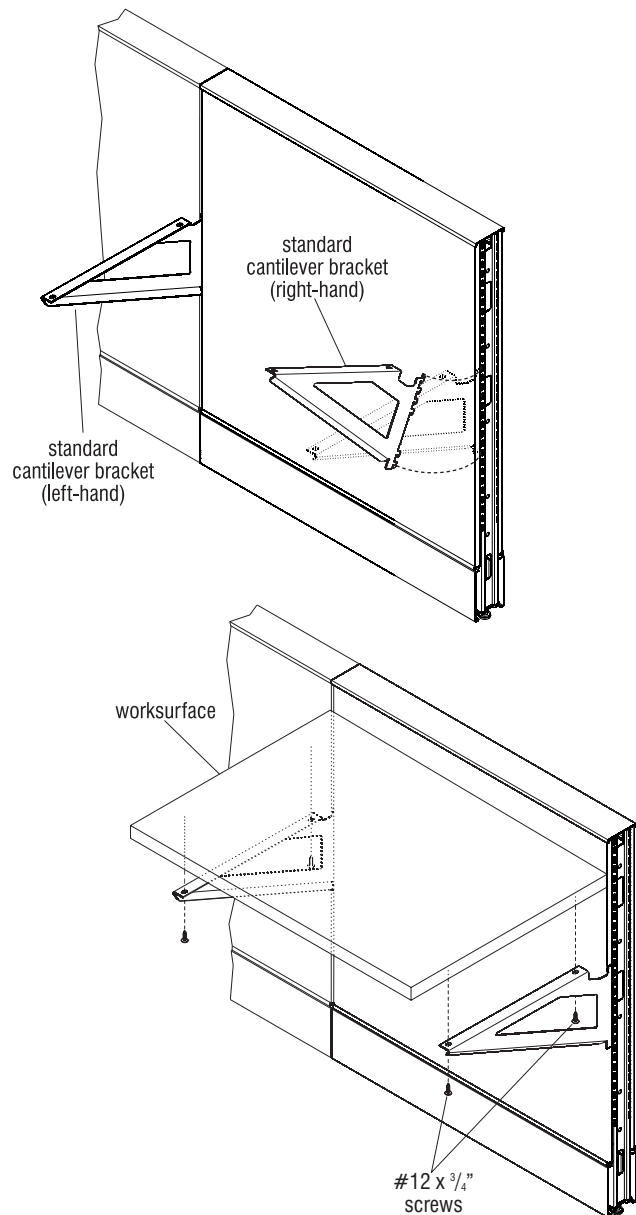

**Figure 1 - Standard Cantilever Bracket Installation**



**CAUTION** Assemble units as described herein only. To do otherwise may result in instability. All screws, nuts and bolts must be tightened securely and must be checked periodically after assembly. Failure to assemble properly, or to secure parts may result in assembly failure and personal injury.

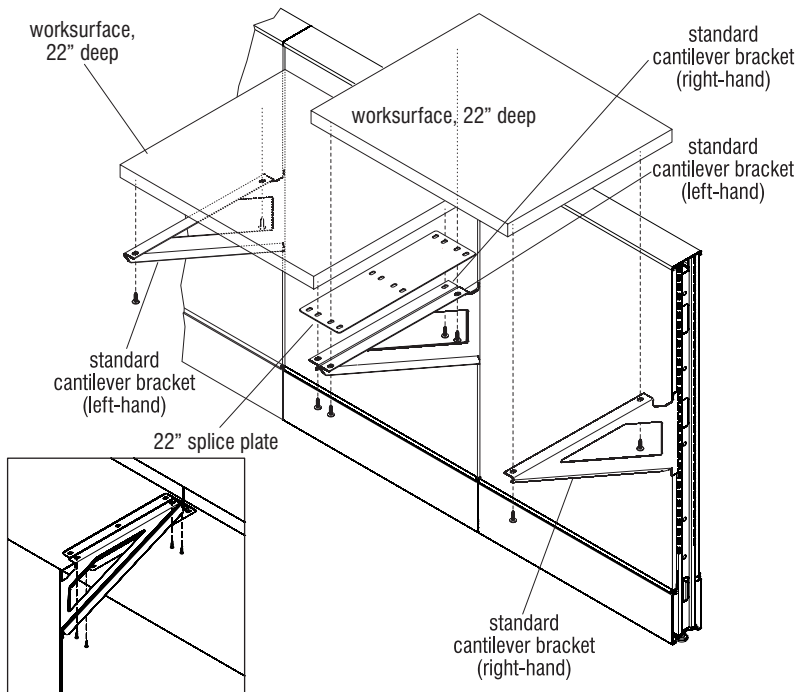

**Figure 2 - Standard Cantilever Bracket Installation with 22" Worksurface**

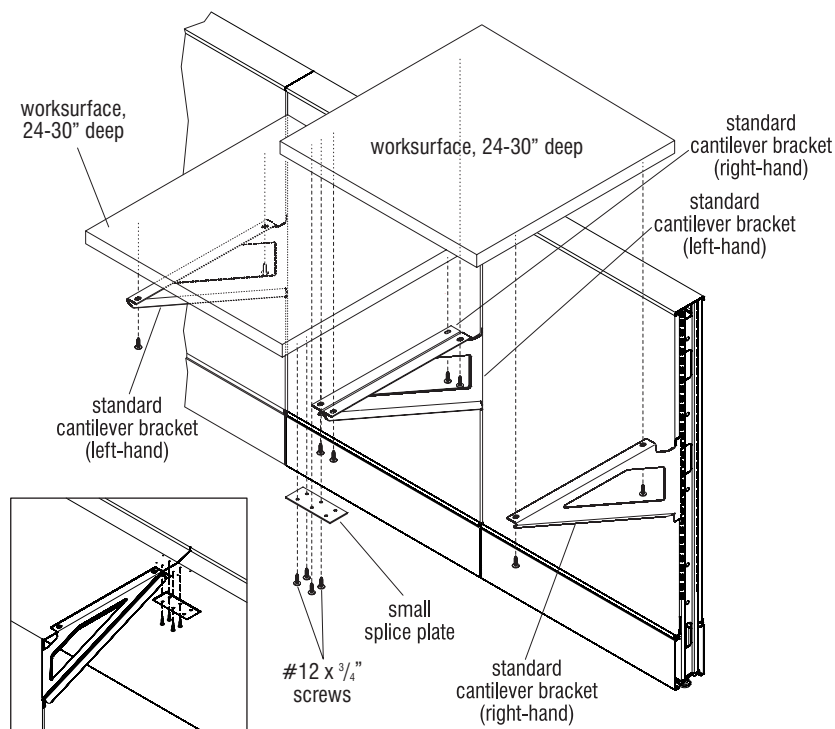

**Figure 3 - Standard Cantilever Bracket Installation with 24-30" Worksurfaces**

**Standard Cantilever Bracket Installation with 22" Deep Worksurface**

**Note:** When 22" deep worksurfaces are installed adjacent to each other, right- and left-hand cantilever brackets will be installed side-to-side with the flat faces touching. Above the cantilever brackets, and spanning under both worksurfaces, a 22" splice plate must be installed between the cantilever brackets and the adjoining worksurface pairs to keep worksurface tops aligned (Figure 2).

1. Install standard cantilever brackets to Unite panels as outlined in steps 1-4 (previous page) (Figure 1).
2. Where two worksurfaces will meet on cantilever brackets, set a 22" splice plate onto the left- and right-hand cantilever bracket pair between panels. Align the support bracket mounting holes over the cantilever bracket mounting holes, then carefully place each worksurface onto cantilever

brackets and align mounting holes of brackets to pre-drilled holes in underside of worksurface. Secure using two #12 x 3/4" screws per bracket. Take care to not over-tighten the screws (Figures 1 & 2).

**Standard Cantilever Bracket Installation with 24-30" Deep Worksurface**

**Note:** When 24-30" deep worksurfaces are installed adjacent to each other, right- and left-hand cantilever brackets will be installed side-to-side with the flat faces touching. A small worksurface splice plate must be installed between the adjoining worksurface pairs, in front of the cantilever bracket pair to keep worksurface tops aligned (Figure 3).

1. Install standard cantilever brackets to Unite panels as outlined in steps 1-4 (previous page) (Figure 1).
2. Carefully place worksurfaces onto installed cantilever brackets and align mounting holes of brackets to pre-drilled holes in underside of worksurfaces. Secure using two #12 x 3/4" screws per bracket. Take care to not over-tighten the screws (Figure 3).
3. To keep worksurfaces level, install a small splice plate between worksurfaces as illustrated. Position the splice plate centered under the installed worksurfaces and use mounting holes as template, then mark mounting hole locations. Pre-drill 1/8" diameter mounting holes to a depth of 1/2" only, taking care to not drill too deep which may damage the worksurface (Figure 5).
4. Install small splice plate to underside of worksurfaces using four #12 x 3/4" screws. Take care to not over-tighten screws (Figure 5).

## ■ Unite® Panel System - Worksurface Installation

Assembly Instructions



Assemble units as described herein only. To do otherwise may result in instability. All screws, nuts and bolts must be tightened securely and must be checked periodically after assembly. Failure to assemble properly, or to secure parts may result in assembly failure and personal injury.

### Perpendicular 24"-30" Deep Worksurface Connections with 74P Edge

**Note:** When 24" & 30" deep 74P edge worksurfaces are installed perpendicular to each other, a worksurface splice plate must be installed between the adjacent worksurface pairs as illustrated to keep worksurface tops aligned. The splice plate, when properly installed will span over the beveled gap (Figure 4).

1. Install standard cantilever brackets to Unite panels as outlined in steps 1-4 (page 58) to the locations outlined in your space-planning layout (Figure 1).
2. Carefully place worksurfaces onto cantilever brackets per space planning layout and align mounting holes of brackets to pre-drilled holes in underside of worksurfaces. Secure using two #12 x  $\frac{3}{4}$ " screws per bracket. Take care to not over-tighten the screws.
3. To keep worksurfaces level, install a small splice plate between adjacent worksurfaces as illustrated. Use the splice plate mounting holes as a template and drill  $\frac{1}{8}$ " diameter holes to not more than  $\frac{1}{2}$ " deep to avoid damaging surface. Install small splice plate to underside of worksurfaces using four #12 x  $\frac{3}{4}$ " screws. Take care to not over-tighten screws (Figure 4).

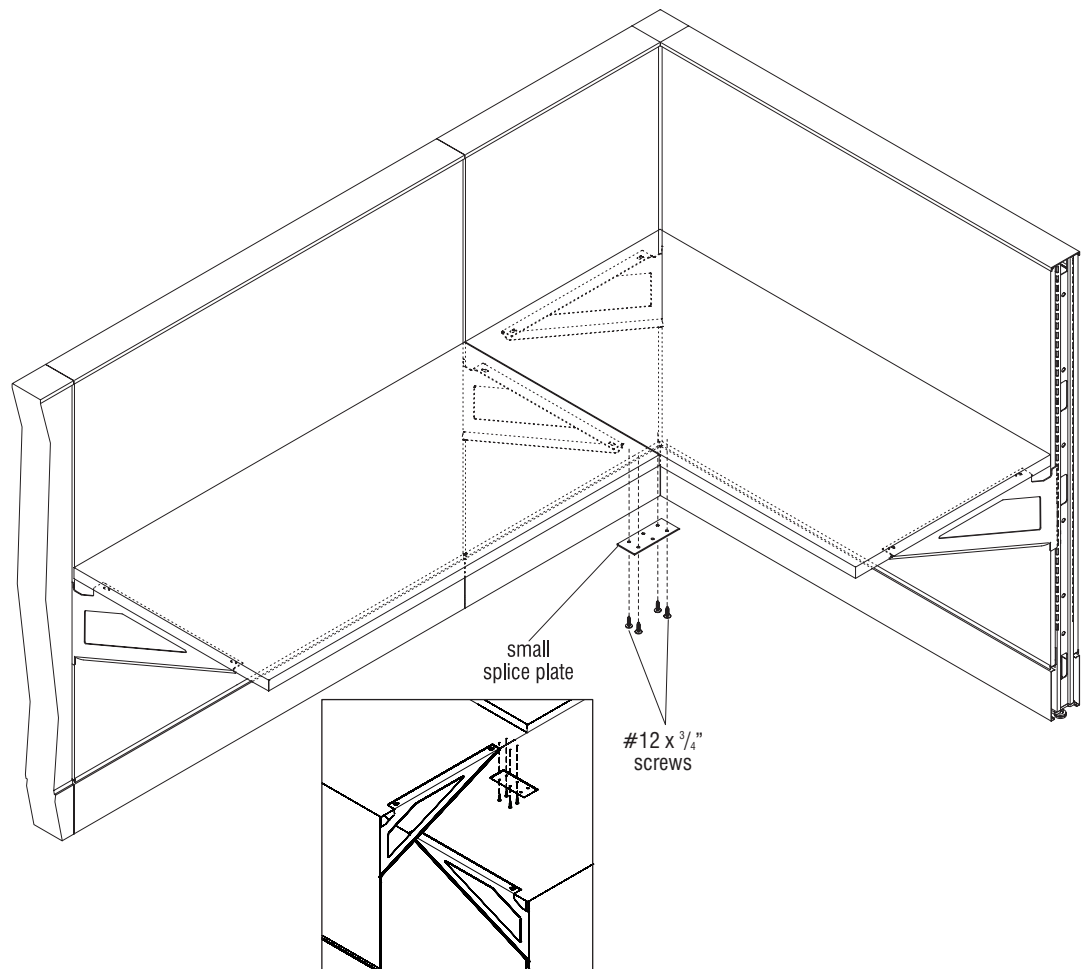

**Figure 4 - Perpendicular 24-30" Deep Worksurface Connections with 74P Edge**



Assemble units as described herein only. To do otherwise may result in instability. All screws, nuts and bolts must be tightened securely and must be checked periodically after assembly. Failure to assemble properly, or to secure parts may result in assembly failure and personal injury.

**Perpendicular 22" & 24" Deep Worksurface Connections with Knife Edge**

**Note:** When a 22" deep Knife Edge worksurface is installed perpendicular to another, a 22" splice plate must be installed between the adjacent worksurface pairs to keep worksurface tops aligned. There is no room to install a small splice plate as the knife edge is 2" deep. The 22" splice plate, when properly installed will span over the beveled gap (Figure 4).

1. Install standard cantilever brackets to Unite panels as outlined in steps 1-4 (page 58) to the locations outlined in your space-planning layout (Figure 1).

2. Carefully place worksurfaces onto cantilever brackets per your space-planning layout and align mounting holes of brackets to pre-drilled holes in underside of worksurfaces. Insert two #12 x 3/4" screws only half-way through each bracket into the worksurface, except at the location where a 22" splice plate will go.

3. Where the two adjoining worksurfaces meet at the cantilever bracket, slide a 22" splice plate between the cantilever and the pair of worksurfaces. Align the outermost mounting holes of the splice plate to the mounting holes of the cantilever bracket such that most of the 22" splice plate extends beneath the adjoining knife edge worksurface that it must support. Secure with two #12 x 3/4" screws through the cantilever bracket, the 22" splice plate and into the worksurface. Take care to not over-tighten screws (Figure 5).

**Note:** When pre-drilling 1/8" dia. holes to underside of worksurface, drill only to a depth of 1/2" to avoid damaging the worksurface.

4. Using the far-side holes of the 22" splice plate as a template under the adjoining surface, take care to drill three 1/8" diameter holes to not more than 1/2" deep in the underside of the worksurface at the mounting hole locations. Insert and tighten three #12 x 3/4" screws. Take care to not over-tighten screws (Figure 5).

5. Tighten all remaining screws to secure cantilever brackets to underside of worksurfaces. Take care to not over-tighten screws (Figure 5).

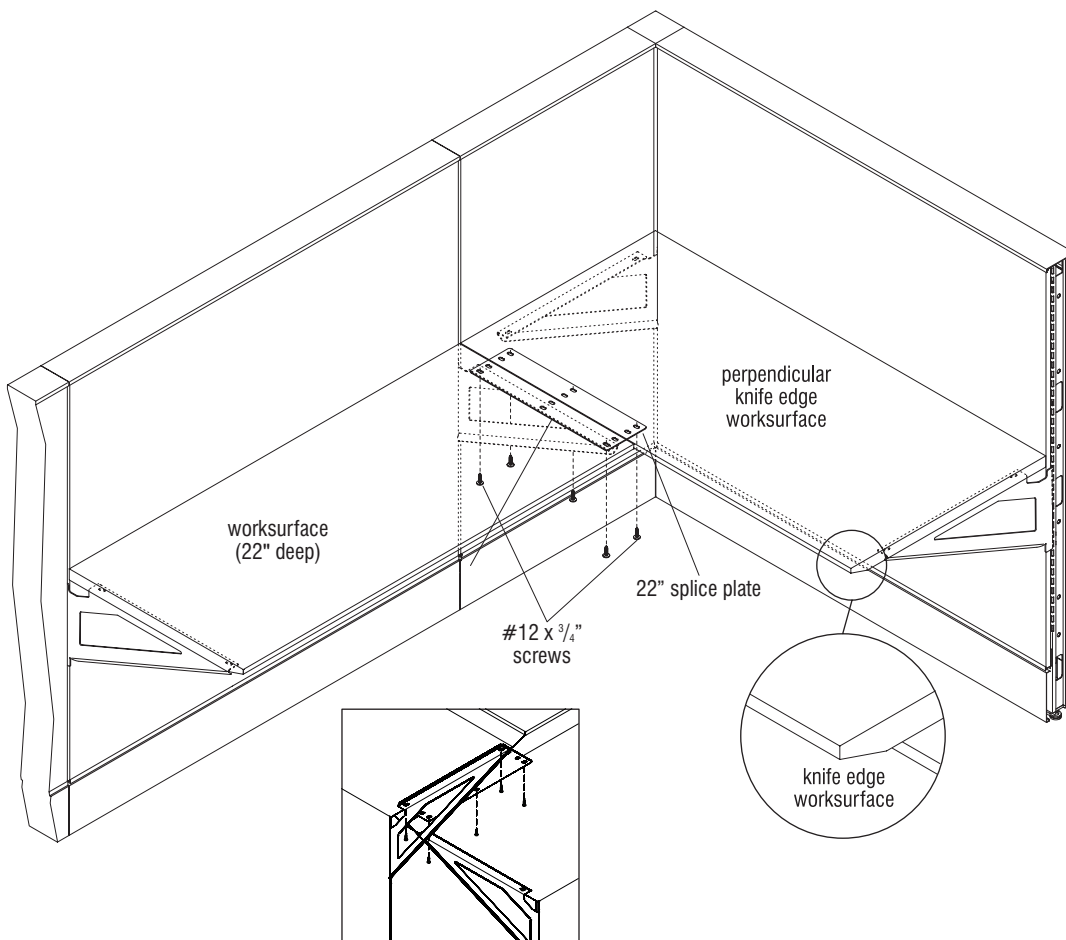

Figure 5 - Perpendicular 22-24" Deep Worksurface Connections with Knife Edge



Assemble units as described herein only. To do otherwise may result in instability. All screws, nuts and bolts must be tightened securely and must be checked periodically after assembly. Failure to assemble properly, or to secure parts may result in assembly failure and personal injury.

**Edge Support Bracket with Lock**

Edge support brackets are left- and right-handed and may be used to secure the front of a worksurface to a panel for extra support.

1. Locate and identify right- or left-hand edge support bracket to be used. A right support bracket is used on the right side of a worksurface as you face the panel and the left-handed bracket is used at the left. The right-hand orientation is shown (Figure 6).

2. Select the bracket height location based on the desired worksurface height. Typical worksurface height is 29" from top of surface to floor. ADA height range is 28"-34".

**Example:** The typical KI worksurface thickness is 1 1/8"; therefore the installed Unite cantilever bracket should measure 27 1/8" from top of bracket to the floor.

3. To install the support bracket, first orient the teeth of the bracket into the panel module slotting at the appropriate height. Ensure that all teeth are inserted firmly, then press bracket down to fully engage all teeth. If necessary, use a rubber mallet to gently tap the top of the bracket to firmly seat the teeth (Figure 6).

4. Align the lock tab bracket as illustrated, such that the mounting flange with two screw holes is positioned under the mounting flange of the edge support bracket. While doing so, insert the lock tooth into the same panel slot as the top tooth of the edge support bracket (Figure 6 & Detail A).

5. Carefully place worksurface onto installed edge support bracket (and cantilever brackets), align mounting holes of brackets to pre-drilled holes in underside of worksurface. Secure using

two #12 x 3/4" screws per edge support bracket and cantilever bracket. Take care to not over-tighten screws (Figure 6 & Detail A).

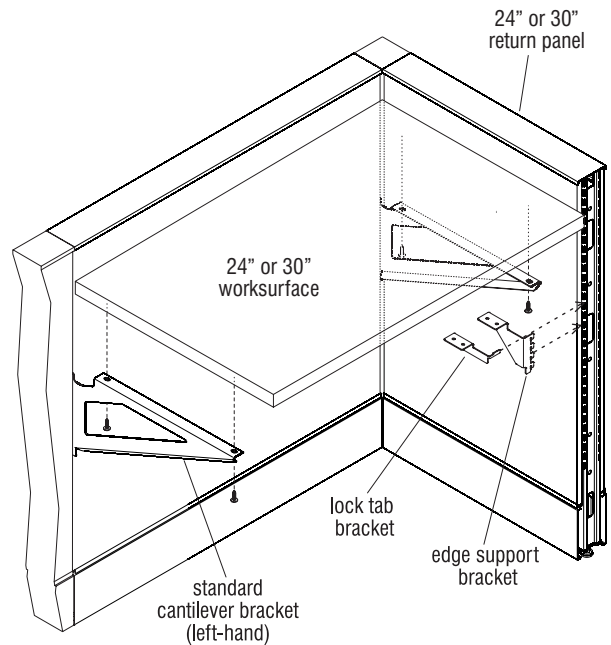

**Figure 6 - Edge Support Bracket with Lock**

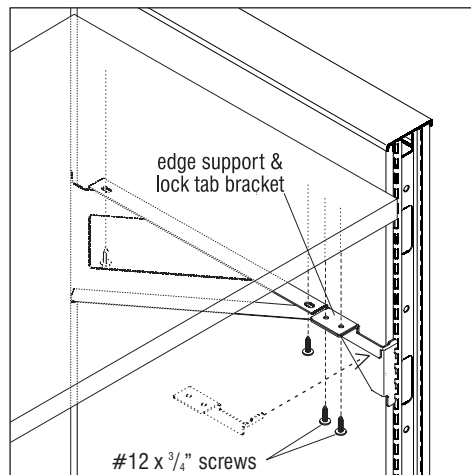

**Detail A - Edge Support Bracket with Lock**



Assemble units as described herein only. To do otherwise may result in instability. All screws, nuts and bolts must be tightened securely and must be checked periodically after assembly. Failure to assemble properly, or to secure parts may result in assembly failure and personal injury.

CAUTION

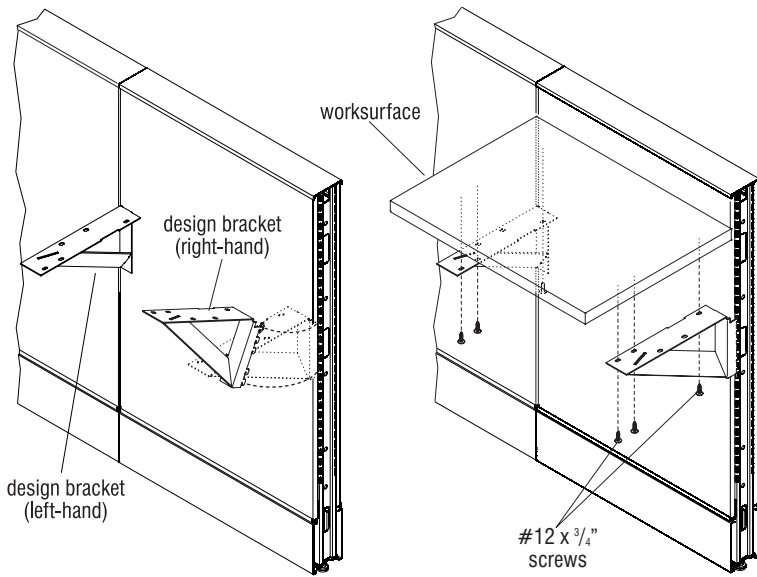

**Figure 7 - Design Bracket & Worksurface Installation**

**Design Bracket Installation**

Design brackets are left- and right-handed and are used to support 18" deep worksurfaces regardless of edge style. They can also be used to support approved peninsula worksurfaces at worksurface only loaded panel returns.

1. Locate and identify right- and left-hand design brackets to be used. A right design bracket is used on the right side of a worksurface as you face the panel and the left-handed bracket is at the left. The outer face of an installed design bracket should appear flush with the edge of the panel surface and the mounting flange must face inward (Figure 7).

3. To install design bracket, first rotate the front of the bracket up as illustrated and insert the top, anti-dislodge tooth into the panel module slotting at the appropriate height. Push up when the top tooth is engaged, then rotate the bottom of the bracket down, engaging all remaining bracket teeth into the slotting. Ensure that all teeth are inserted firmly, then press bracket down to fully engage all teeth. If necessary, use a rubber mallet to gently tap the top of the bracket to firmly seat the teeth. Repeat the steps above for the second design bracket to be installed (Figure 7).

**Design Bracket with 18" Worksurface with 74P & Knife Edge**

**Note:** When worksurfaces are installed adjacent to each other, right- and left-hand design brackets will be installed side-to-side with the flat faces mated (Figure 7).

2. Select the bracket height location based on the desired worksurface height. Typical worksurface height is 29" from top of surface to floor. ADA height range is 28" - 34".

**Example:** The typical KI worksurface thickness is 1.18"; therefore the installed Unite design bracket should measure 27<sup>7/8</sup>" from top of bracket to the floor.

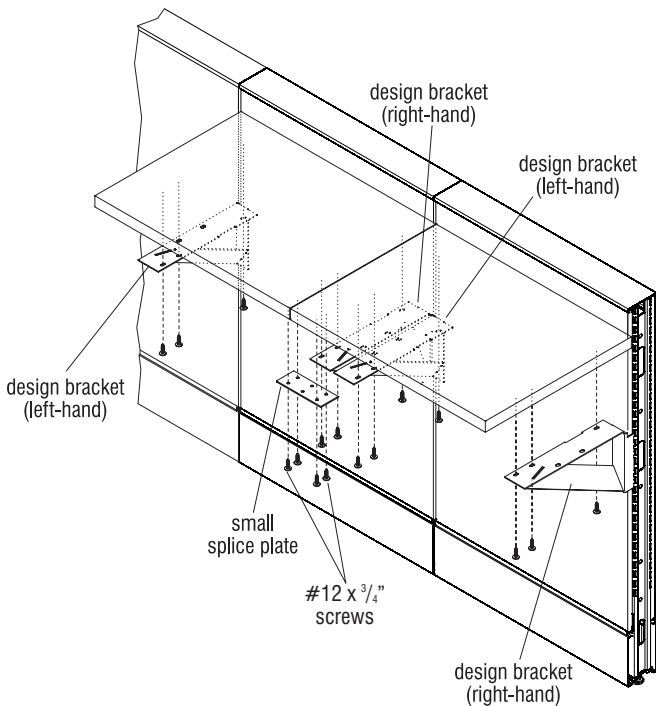

**Figure 8 - Design Bracket with 18" Worksurface with 74P & Knife Edge**

5. Carefully place worksurface onto installed design brackets and align mounting holes of brackets to pre-drilled holes in underside of worksurface. Secure using two #12 x 3/4" screws per bracket. Take care to not over-tighten the screws (Figures 7 & 8).
6. To keep worksurfaces level, install a small splice plate between worksurfaces as illustrated. Position the splice plate centered under the installed worksurfaces and use mounting holes as template, then mark mounting hole locations. Pre-drill 1/8" dia. mounting holes to a depth of 1/2" only, taking care to not drill too deep which may damage the worksurface (Figure 8).
7. Install worksurface splice plate to underside of worksurfaces using four #12 x 3/4" screws. Take care to not over-tighten screws (Figure 8).

# Unite® Panel System - Worksurface Installation

## Assembly Instructions



Assemble units as described herein only. To do otherwise may result in instability. All screws, nuts and bolts must be tightened securely and must be checked periodically after assembly. Failure to assemble properly, or to secure parts may result in assembly failure and personal injury.

### Peninsula Surfaces with Add-On Peninsula Attachment Plate Installation

An add-on peninsula attachment plate is used at the attachment end of an approved peninsula worksurface with approved support at the opposite end (i.e. a pair of post legs, support frame or pedestal). The attachment plate secures an approved peninsula surface to the underside of an approved panel-attached worksurface at various locations. Your installation location may be different than example shown.

1. Lay the peninsula worksurface down on a soft, protective surface. At the front end of the surface, install approved support such as a Unite support leg or a pair of post legs (shown installed) (Figure 10).

**Note:** Peninsula worksurfaces are to be less than 72" in length, and are offered in 22", 24" & 30" widths.

2. Lay a peninsula attachment plate onto the end of the peninsula surface opposite the support(s). Center the plate from side-to-side and position the overhang of the plate allowing 2 1/2" for attachment to the panel-attached worksurface. Using the properly positioned attachment plate as a template, mark the center of all attachment hole locations to the underside of the peninsula surface. Remove the plate, and using a drill with a 1/8" drill bit, carefully drill pilot holes to only 1/2" depth in peninsula surface underside at center of marked locations. Take care to not drill too deep to avoid damaging worksurface.

**Note:** 30" wide peninsula surfaces will use a mounting plate with 7 mounting holes in the plate per surface, and 24" wide peninsula surfaces will use a plate with 6 mounting holes each side.

3. Replace the attachment plate over the pilot holes and secure plate to underside of peninsula surface using #12 x 3/4" screws. Take care to not over-tighten screws.
4. Using an assistant, carefully turn the peninsula surface upright and position the attachment plate to the underside of the panel attached worksurface, at the location the peninsula will secure to. Similar to step 2 above, mark mounting holes through the plate to the underside of the panel attached worksurface. Remove the peninsula surface and pre-drill mounting holes on the marks at the underside of the panel attached surface, to 1/2" in depth only.
5. Place the peninsula surface with attachment plate back under the panel attached surface and secure plate to underside of surface using #12 x 3/4" screws. Take care to not over-tighten screws.

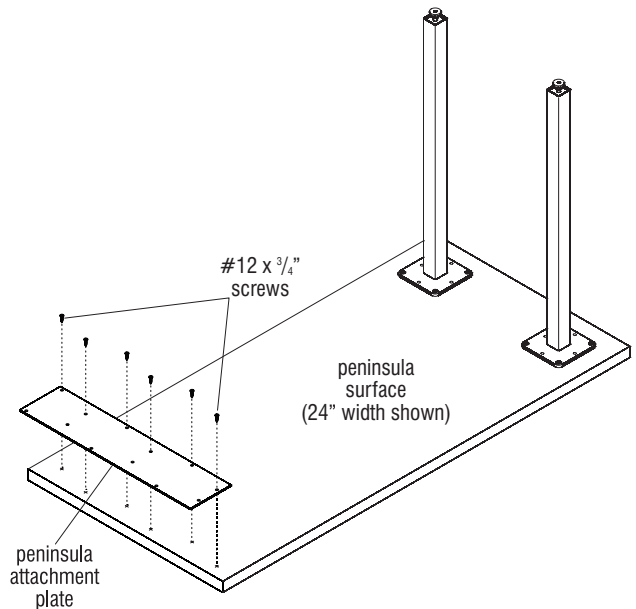

Figure 10 - Peninsula Attachment Plate Installation

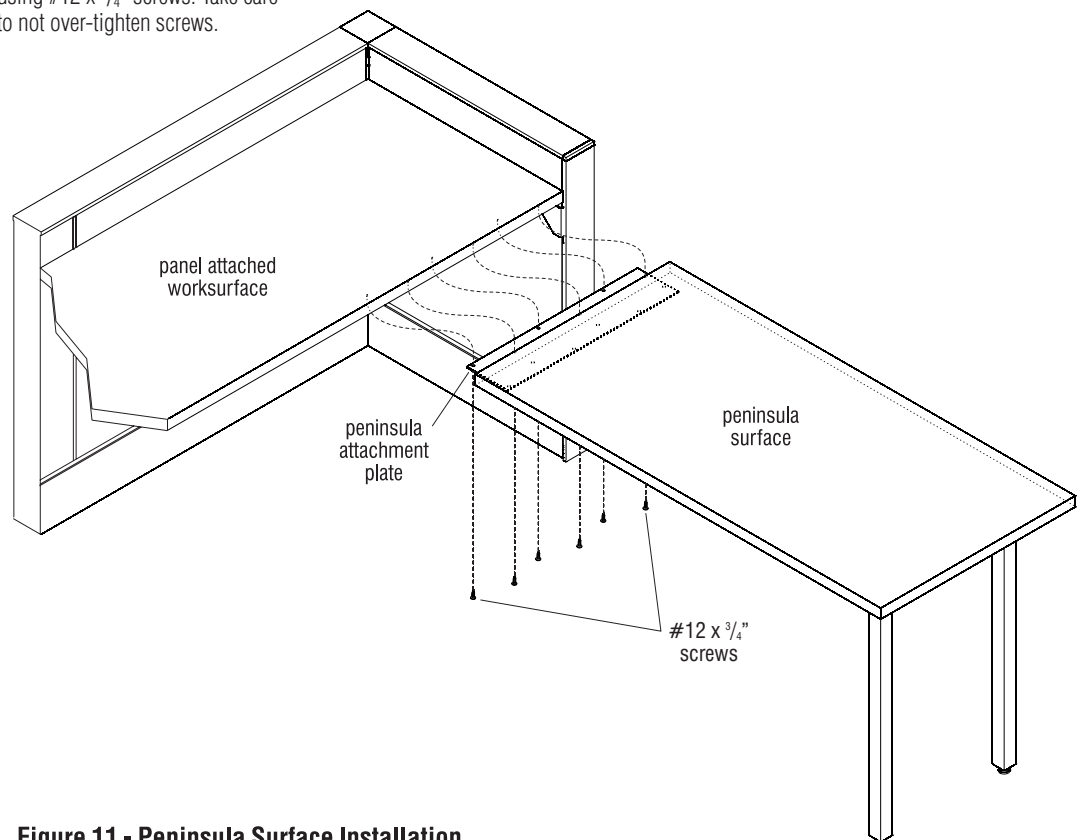
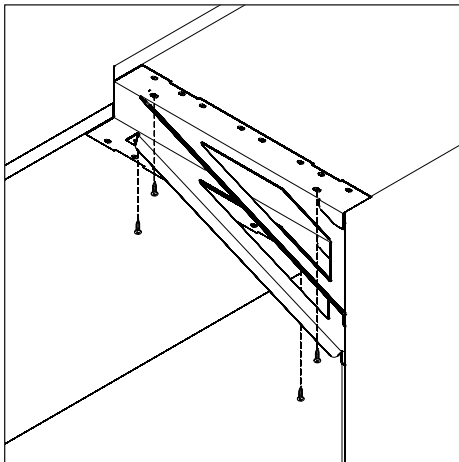

Figure 11 - Peninsula Surface Installation





Assemble units as described herein only. To do otherwise may result in instability. All screws, nuts and bolts must be tightened securely and must be checked periodically after assembly. Failure to assemble properly, or to secure parts may result in assembly failure and personal injury.



**Detail B - In-Line Change-of-Height Bracket**

**Change-of-Height Bracket Overview**

Change-of-height brackets are used when adapting from 26" high worksurface planning to 29" high worksurface planning. Two styles are available: In-line and Corner.

**In-line Change-of-Height Brackets**

are used when changing worksurface heights in-line along a panel. The in-line change of height bracket takes the place of a splice plate and requires cantilever

bracket support beneath both upper and lower height-change worksurfaces. Cantilever brackets are shown, but if either worksurface is 18" depth (74P or KN edge style) the 12" design brackets are used beneath that worksurface. Change-of-height brackets are available in different lengths, for worksurfaces from 18" to 30", including KN.

1. Select the bracket height location based on the desired worksurface height. Typical worksurface height is 29" from top of surface to floor. ADA height range is 28"-34".

**Example:** The typical KI worksurface thickness is 1 1/8"; therefore the installed Unite design bracket should measure 27 7/8" from top of bracket to the floor.

2. Install all lower and upper-height worksurface support brackets per the space-planning layout. The upper worksurface bracket should be installed 3" (3-slots) higher than the lower bracket.
3. Place the in-line change-of-height bracket onto both support brackets as illustrated, positioning the back of the bracket to the panel and aligning mounting holes and slots of brackets (Figure 12 & Detail B).
4. Carefully place worksurfaces onto installed support brackets and change-of-height bracket then align mounting holes of brackets to pre-drilled holes in underside of worksurfaces. Secure using two #12 x 3/4" screws (Figure 12 & Detail B).

**Note:** For design bracket at change-of-height bracket, use the front and rear slots as no screw is required in the middle slot.

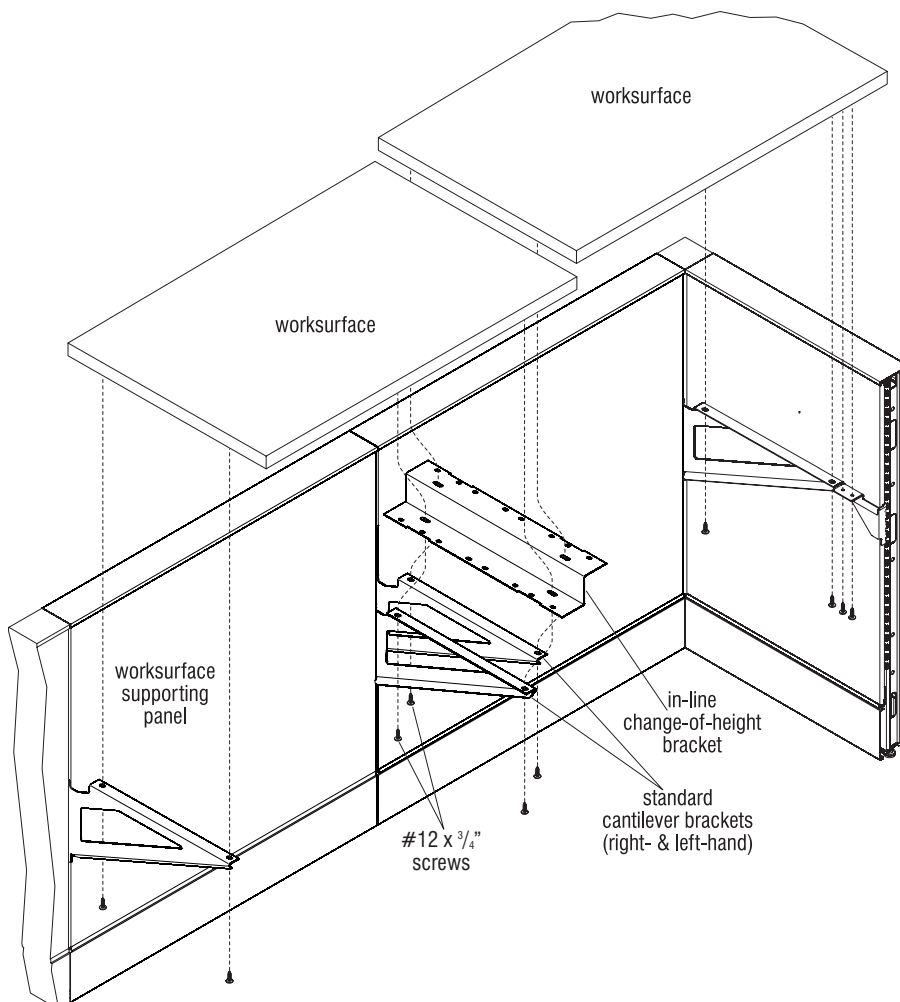

**Figure 12 - In-Line Change-of-Height Bracket**



Assemble units as described herein only. To do otherwise may result in instability. All screws, nuts and bolts must be tightened securely and must be checked periodically after assembly. Failure to assemble properly, or to secure parts may result in assembly failure and personal injury.

### Corner Change-of-Height Brackets

Brackets are used when changing worksurface heights at a corner. Use of this bracket requires that support brackets used for the lower worksurface be of approved support style for that worksurface/panel configuration. Only the lower worksurface may function as a return surface which is panel supporting. Corner change of height brackets are available in different lengths, for worksurfaces from 18" to 30", including KN.

1. Select the bracket height location for the lower worksurface based on the desired worksurface height. Typical worksurface height is 29" from top of surface to floor. ADA height range is 28" - 34".

**Example:** The typical KI worksurface thickness is 1 1/8"; therefore the installed Unite design bracket should measure 27 7/8" from top of bracket to the floor.

2. Install the lower worksurface completely. Per the space-planning layout, the lower worksurface depth must match the width of the adjacent panel. The lower worksurface must be installed with an approved support bracket (cantilever bracket shown) on the back corner edge along with a worksurface edge support and lock on the other edge. For the example illustrated in Figure 13, the opposite end of the lower surface uses a non-panel mounted open leg (Figure 13).

3. Carefully place "upper" worksurface face down on a soft protective surface. At the narrow edge of the table which will rest on the lower table, install a change-of-height bracket with #12 x 3/4" screws as illustrated (Figure 14).

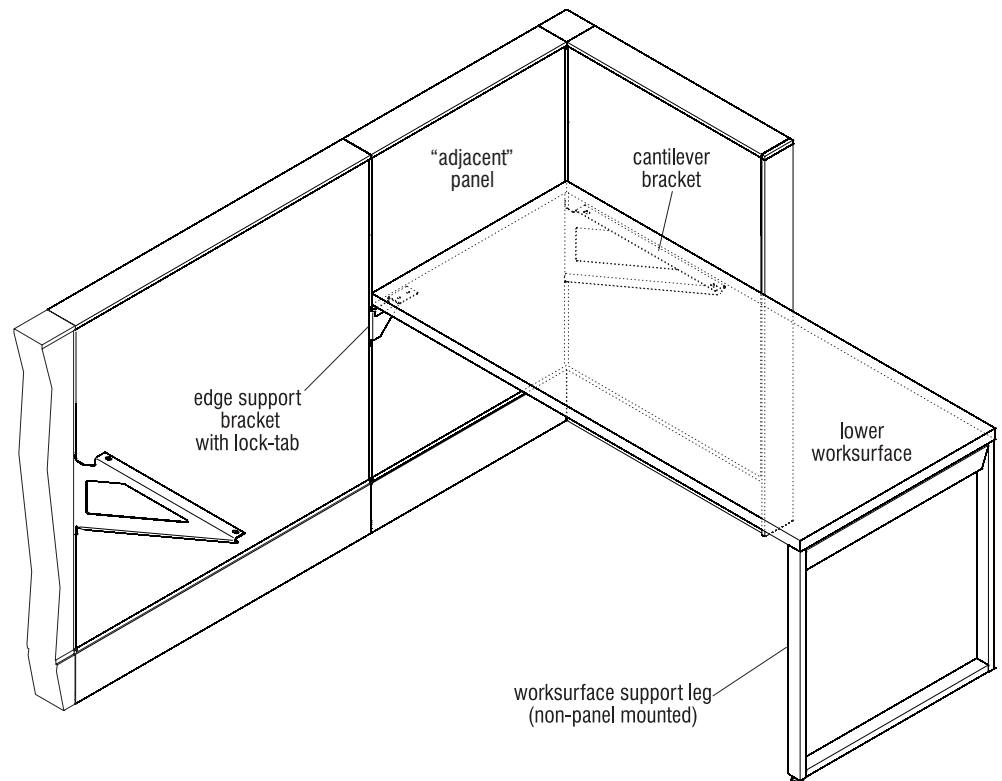

Figure 13 - Corner Change-of-Height Bracket (Lower Worksurface Installation)

4. At the back edge of the upper worksurface, near the end with the installed change-of-height bracket, position an L-bracket at 6" from the side edge. The back edge of the L-bracket should overhang the rear of the table surface by the thickness of the vertical member of the bracket. Using the properly positioned bracket mounting hoes as a template, carefully drill two 1/8" dia. pilot holes to 1/2" in depth. Take care to not drill too deep or worksurface may be damaged. Install L-bracket to worksurface using two #12 x 3/4" screws. Take care to not over-tighten screws (Figure 14).

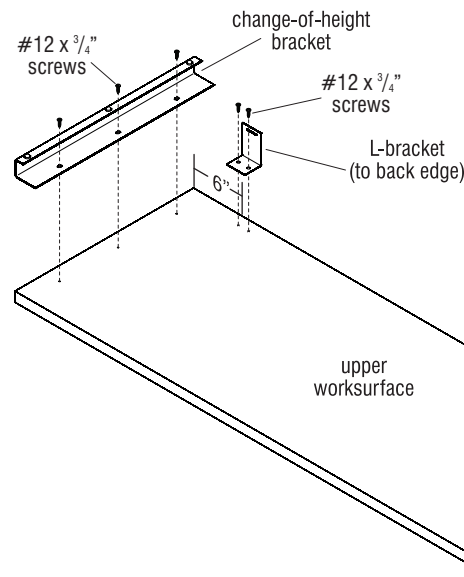

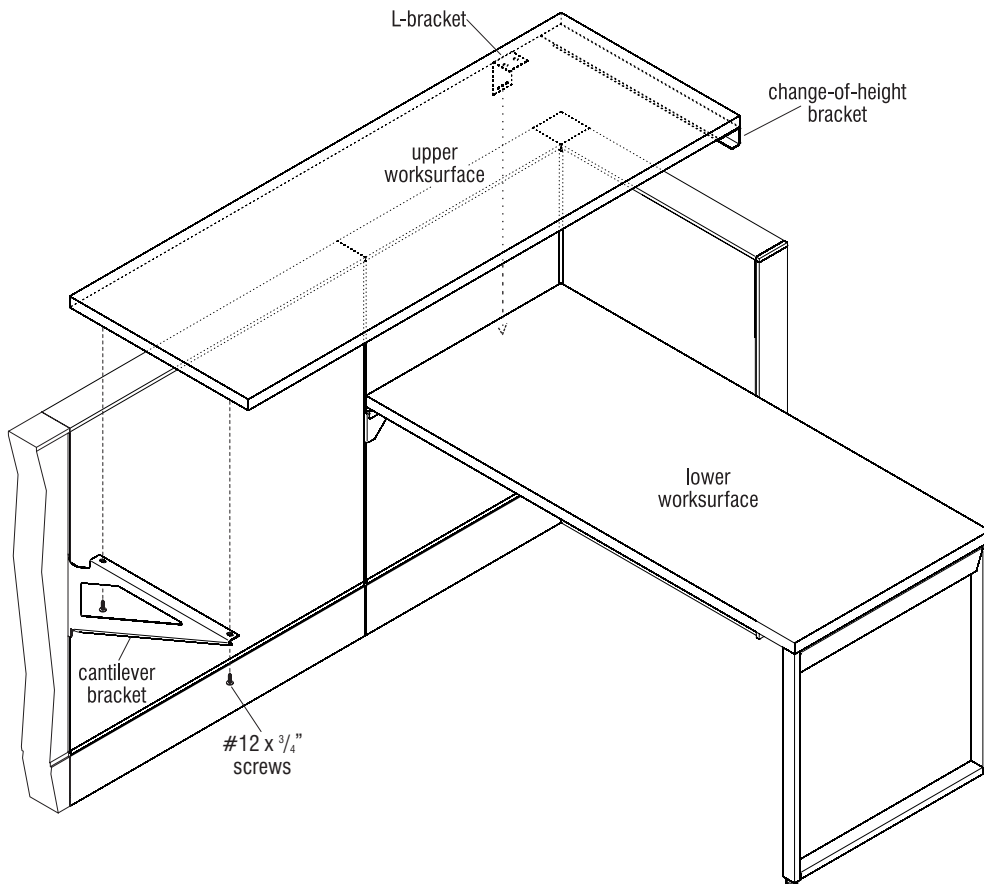

Figure 14 - Corner Change-of-Height Bracket (Upper Worksurface Assembly)



**CAUTION** Assemble units as described herein only. To do otherwise may result in instability. All screws, nuts and bolts must be tightened securely and must be checked periodically after assembly. Failure to assemble properly, or to secure parts may result in assembly failure and personal injury.



**Figure 15 - Corner Change-of-Height Bracket (Upper Worksurface Installation)**

5. Turn the upper worksurface to the upright position and set into place on the lower worksurface and cantilever bracket, carefully guiding the installed L-bracket between the edge of the lower worksurface and the Unite panel. Press in on the panel to allow the L-bracket to pass through, taking care to not damage the panel material or the lower worksurface (Figure 15).
6. At the non change-of-height end, align the pre-drilled mounting holes in the worksurface underside with the holes in the cantilever bracket and secure with two #12 x 3/4" screws to secure. Take care to not over-tighten the screws (Figure 15).
7. Working under the lower worksurface at the change-of-height end, engage the tang of the lock bracket into the slot of the L-bracket that protrudes below the worksurface underside. Gently push in on the tile material to give the tang of the lock bracket room to rotate up to be flush with the worksurface underside. Carefully drill two 1/8" diameter pilot holes to no more than 1/2" deep through the center of the lock bracket's mounting holes. Take care to not drill too deep to avoid damage to the worksurface. Secure the lock bracket using two #12 x 3/4" screws (Detail C).

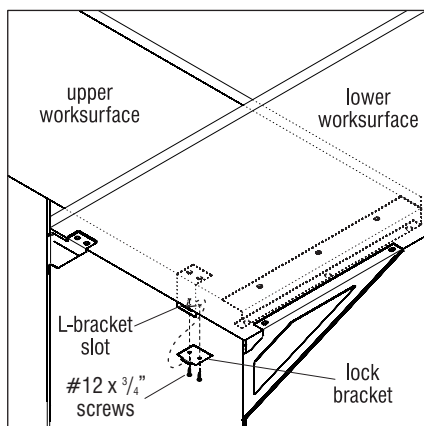

**Detail C - Lock Bracket**



Assemble units as described herein only. To do otherwise may result in instability. All screws, nuts and bolts must be tightened securely and must be checked periodically after assembly. Failure to assemble properly, or to secure parts may result in assembly failure and personal injury.

### Peninsula & Conference End Worksurfaces

Peninsula and conference end worksurfaces are installed to the Unite Panel System with approved brackets on one end and utilize either a worksurface support leg or a set of post legs as support at the outside end of the worksurface. Space-planning layout will outline the components to be used.

1. Carefully turn the peninsula or conference end worksurface upside down onto a soft, protective surface. Determine which end of the worksurface to install either a pair of post legs or a worksurface support leg. If post legs are used, follow step 2 below then skip to step 4, next page. If a support leg is used, skip now to step 3, then continue on to step 4, next page.
2. Position both post legs onto the underside of the worksurface, square to the corner with the edge of the mounting flanges spaced  $2\frac{1}{4}$ " from the outside edges of the worksurface as illustrated. Using the mounting flanges as a template, carefully drill four  $\frac{1}{8}$ " diameter holes to no more than  $\frac{1}{2}$ " deep into underside of worksurface at both post leg mounting brackets. Take care to not drill too deep or damage to the surface may occur. Secure each post leg to the underside of the worksurface using four  $\#12 \times \frac{3}{4}$ " screws. Take care to not over-tighten the screws (Figure 16).
3. Position a worksurface support leg onto the underside of the worksurface, centered and flush with the end and over pre-drilled mounting holes. Secure to the underside of the worksurface using six  $\#12 \times \frac{3}{4}$ " screws. Take care to not over-tighten the screws (Figure 17).

**Caution:** Non-panel supporting worksurface support legs cannot be used to make stand-alone tables because the leg does not contain the "racking" stability required.

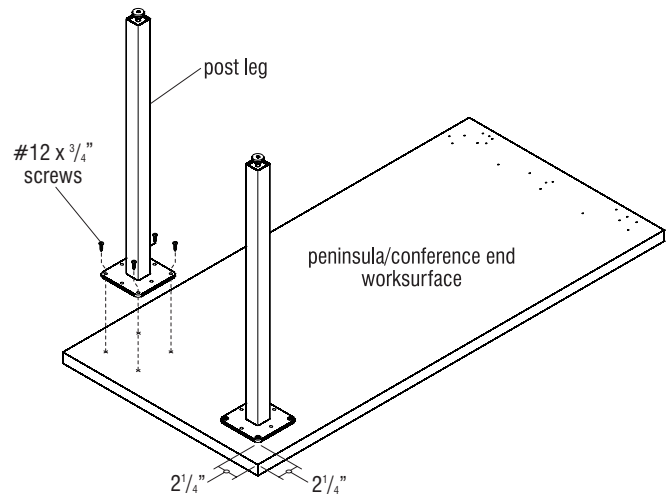

Figure 16 - Post Leg to Peninsula/Conference End Worksurfaces

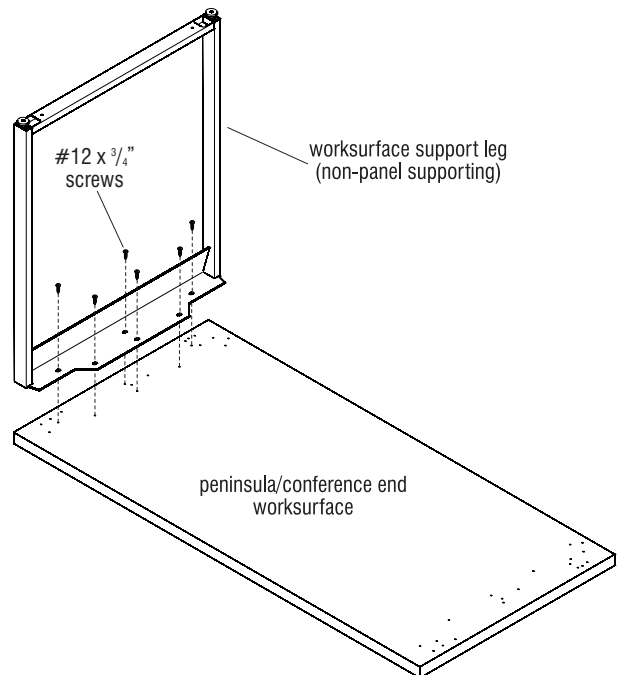
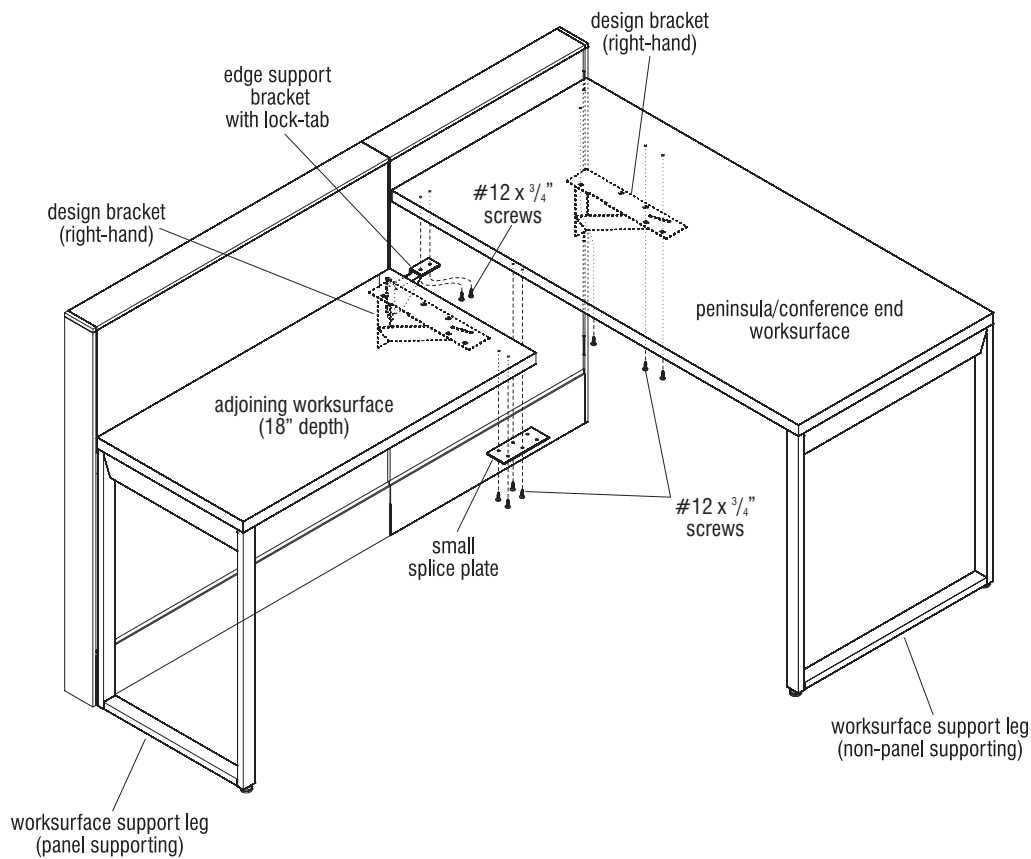
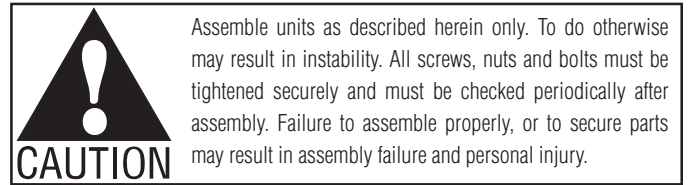

Figure 17 - Worksurface Support Leg to Peninsula/Conference End Worksurfaces



**Figure 18 - Peninsula/Conference End Worksurface Installation**

4. Carefully turn the peninsula or conference end worksurface right-side up next to the adjoining worksurface and position the panel-mount end onto the mounting brackets installed to the panel (edge support bracket and design bracket illustrated). Align the pre-drilled holes in the underside of the worksurface with the mounting holes in the brackets and secure using #12 x 3/4" screws. Take care to not over-tighten mounting screws (Figure 18).
5. Position a small splice plate under both the peninsula/conference end worksurface and the adjoining worksurface as illustrated. Align small splice plate to pre-drilled mounting holes under both worksurfaces and secure using two #12 x 3/4" screws per worksurface underside. Take care to not over-tighten screws (Figure 18).

# Unite® Panel System - Worksurface Installation

## Assembly Instructions



Assemble units as described herein only. To do otherwise may result in instability. All screws, nuts and bolts must be tightened securely and must be checked periodically after assembly. Failure to assemble properly, or to secure parts may result in assembly failure and personal injury.

### Worksurfaces to Panel Mounted Support Legs

Three panel mounted support leg styles may be used per space-planning layout: right-hand, left-hand & center (Figure 19). Each installs to Unite panels in the same manner to provide worksurface support and can be used in place of panel returns to support panel runs. Tiles must be installed to properly installed panels before installing support legs.

**Important:** Prior to installing any panel mounted support legs, ensure that all Unite panel glides are set to their final height, that the run of panels is level, and at its final floor location.

1. Per space-planning layout, determine which (right, left & center) support legs are to install where along the run of panels and stage accordingly (Figure 19).

**Note:** The bottom of the panel mounted support leg was designed to align with the bottom of the raceway cover of the Unite panel for aesthetic reasons. When choosing slot location to install support leg, take this into consideration.

2. Screw the adjustable glide at the bottom, front end of the panel mounted support leg all of the way in to the bottom of the frame prior to installation (Figure 19).

3. Locate the lock bracket at the top of the support leg and loosen the two nuts, but do not remove them. Grip the lock bracket studs and raise the lock bracket. Install the support leg by inserting both the stationary teeth on the support leg and the lock bracket teeth into the slots in the vertical post of the Unite panel (Figure 19).

Continued on next page...

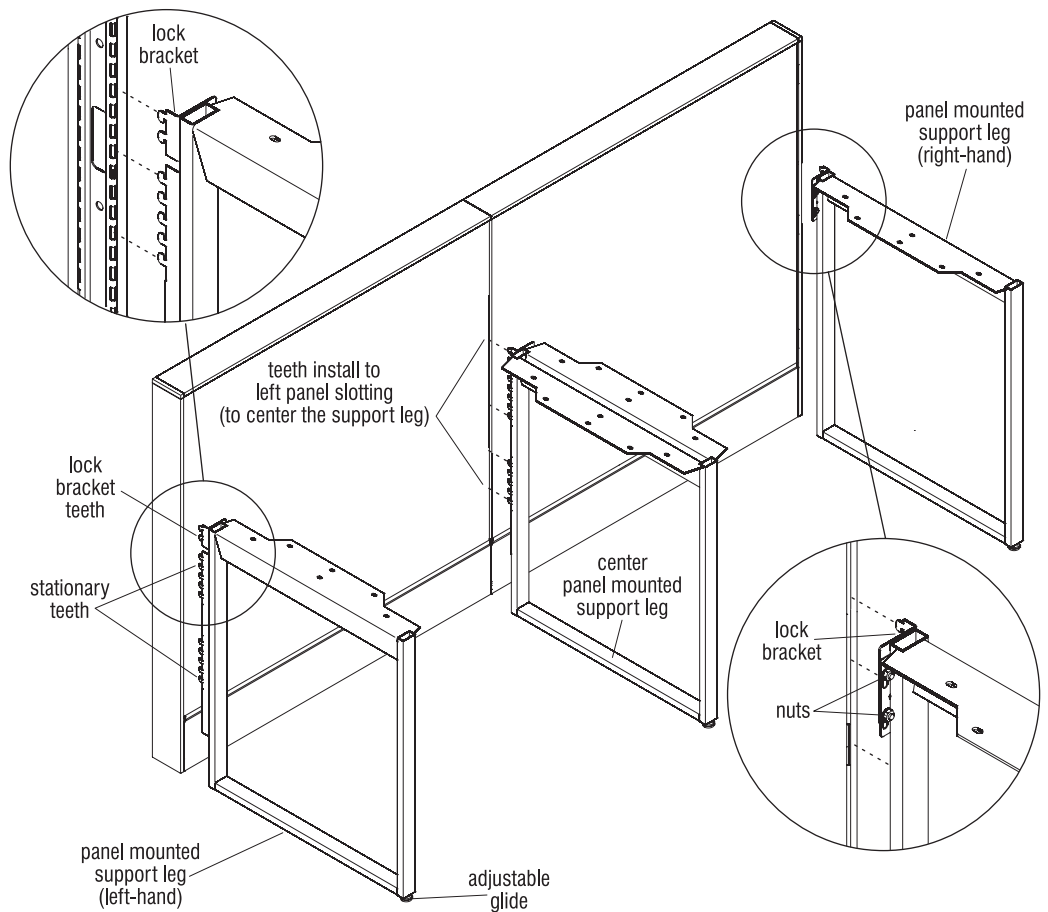
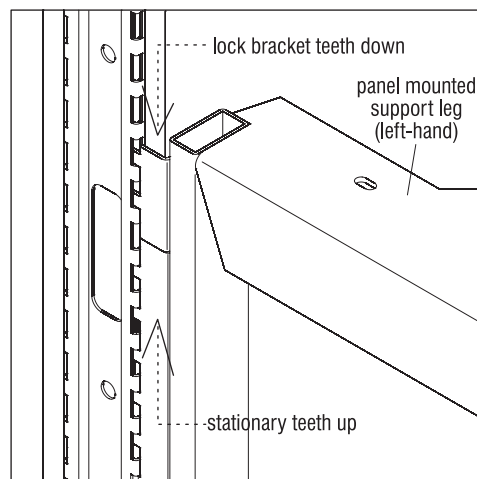
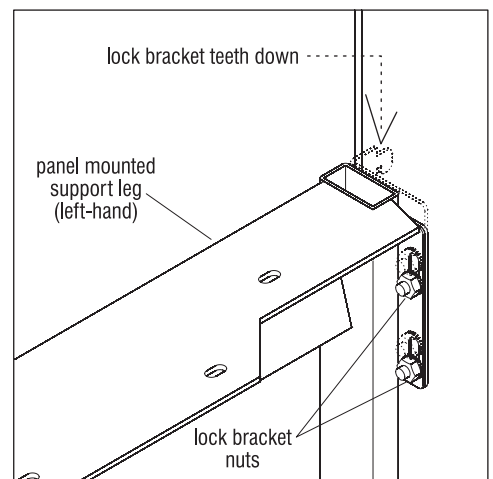



Figure 19 - Panel Mounted Support Legs



Detail D - Lock Bracket to Lock



Detail E - Lock Bracket Nuts Tight



Assemble units as described herein only. To do otherwise may result in instability. All screws, nuts and bolts must be tightened securely and must be checked periodically after assembly. Failure to assemble properly, or to secure parts may result in assembly failure and personal injury.

**CAUTION**

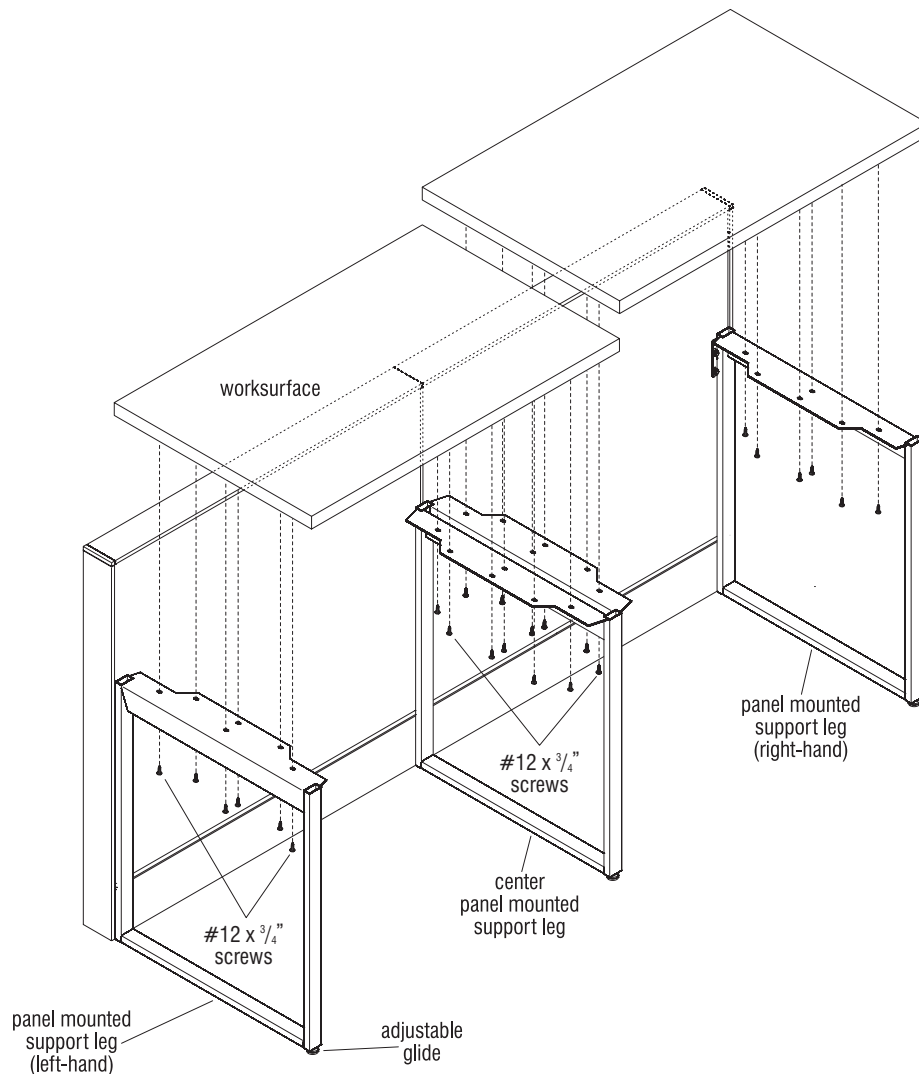

**Important:** Right- and left-hand support legs install to the panel slotting of the same panel as the worksurface. Center panel mounted support legs are installed such that the teeth engage the panel that is opposite the side with lock bracket nuts, thus centering the center support leg at the seam between panels (Figure 19).

**Note:** It is important to install all panel mounted support legs at the same time, including any required at the opposite side of the panel wall. Support leg glide adjustment and securing of lock brackets must be done only after all panel mounted support legs are installed.

4. With all teeth of the support leg set into the notches of the panel, and all support legs installed, adjust the glides downward to raise the leg and engage the upward facing teeth. Then grip both studs of the lock bracket and slide the lock bracket down until the teeth are fully seated against the panel slot faces. Ensure that both the upward facing stationary teeth and the downward facing lock bracket teeth are tight against the slot faces in both the up and down directions. Tighten the lock bracket nuts to secure the support leg to the panel (Figure 19, Details D & E).
5. Adjust all glides so support leg tops are level front to back prior to installing worksurfaces (Figure 20).
6. Set worksurfaces onto Panel mounted support leg pairs one at a time. Align pre-drilled holes at underside of worksurface with mounting holes of support legs and secure with #12 x 3/4" screws. Use six screws at each support leg and take care to not over-tighten screws (Figure 20).

**Figure 20 - Worksurfaces to Support Legs**

# Unite® Panel System - Worksurface with Pedestal Support Installation

## Assembly Instructions



Assemble units as described herein only. To do otherwise may result in instability. All screws, nuts and bolts must be tightened securely and must be checked periodically after assembly. Failure to assemble properly, or to secure parts may result in assembly failure and personal injury.

### Pedestal to Panel with Worksurface Installation

The Unite Panel System offers pedestals and double pedestal lateral files (Figure 21) as support for worksurfaces of indicated depths. A space-planning layout details correct worksurface configurations, panel support bracket types, and pedestal to panel support brackets. The following steps do not cover every assembly combination; please reference the appropriate bracket layout instructions earlier in this worksurfaces section for proper installation.

**Important:** Worksurfaces must be supported at both ends.

### Pedestal/Double Pedestal to Panel Support Bracket

1. One of four brackets is specified to attach a pedestal to the panel wall, depending on worksurface type, depth, and according to space-planning layout. A support bracket with no spacer is only used on 22" deep worksurfaces and 24" deep with Knife Edge. Brackets with spacers are used to extend the pedestal out from the panel to match the depth of the worksurface (24", 30", and 30" Knife Edge)(Figure 21).

**Note:** The pedestal mounts to the panel and worksurface the same regardless of bracket type (Figure 21).

### Removing Drawers

**Note:** To ease the assembly of support brackets to cabinets and cabinets to worksurfaces, all file drawers should be removed.

3. Empty the contents of file drawers and open drawer until suspension is fully extended (Figure 22).
4. Using a slot screwdriver, place tip between the drawer body and the suspension, near the slip connection (Detail F).

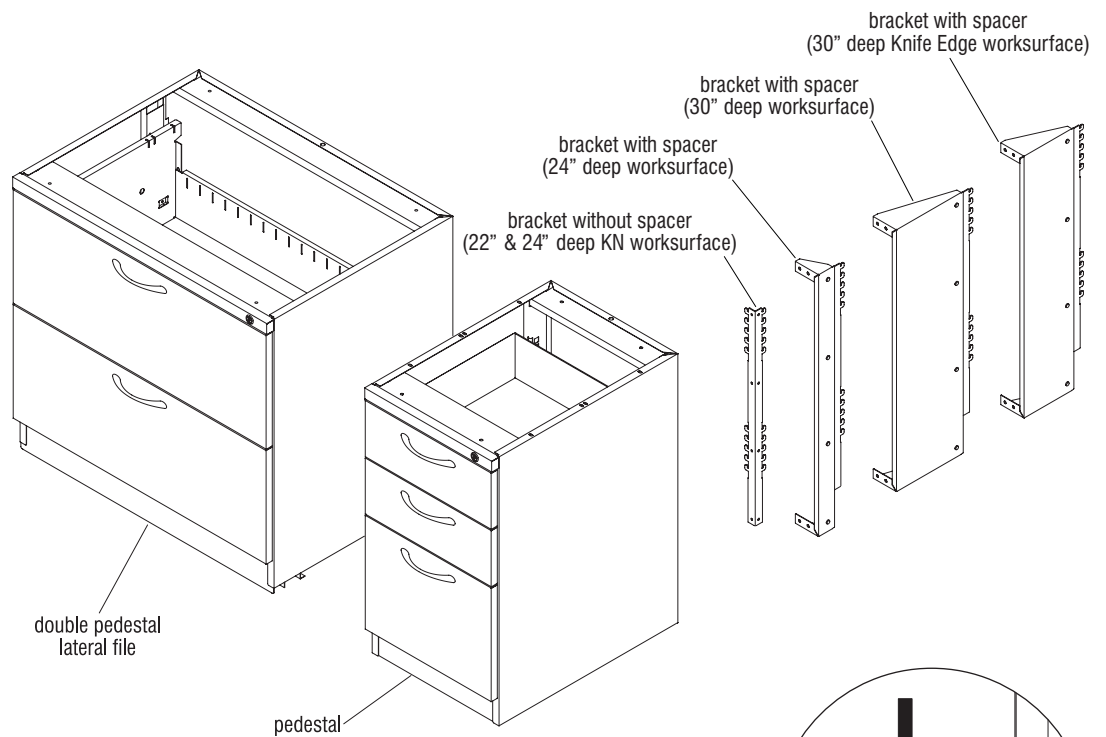
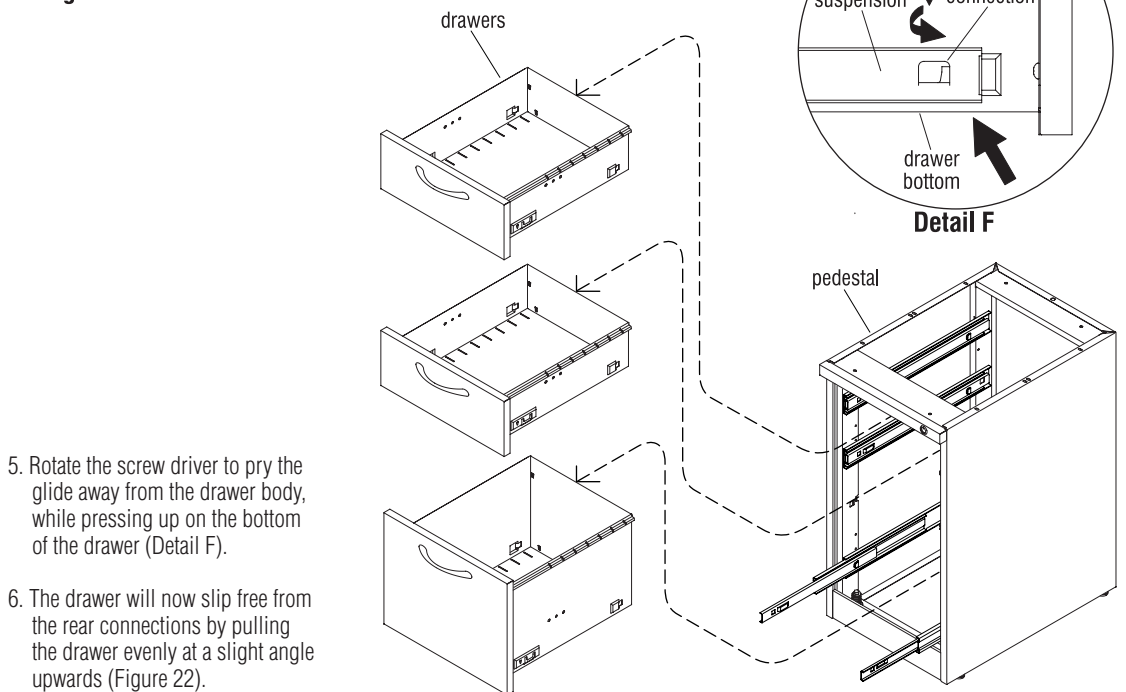



Figure 21



5. Rotate the screw driver to pry the glide away from the drawer body, while pressing up on the bottom of the drawer (Detail F).
6. The drawer will now slip free from the rear connections by pulling the drawer evenly at a slight angle upwards (Figure 22).

Figure 22





**CAUTION** Assemble units as described herein only. To do otherwise may result in instability. All screws, nuts and bolts must be tightened securely and must be checked periodically after assembly. Failure to assemble properly, or to secure parts may result in assembly failure and personal injury.

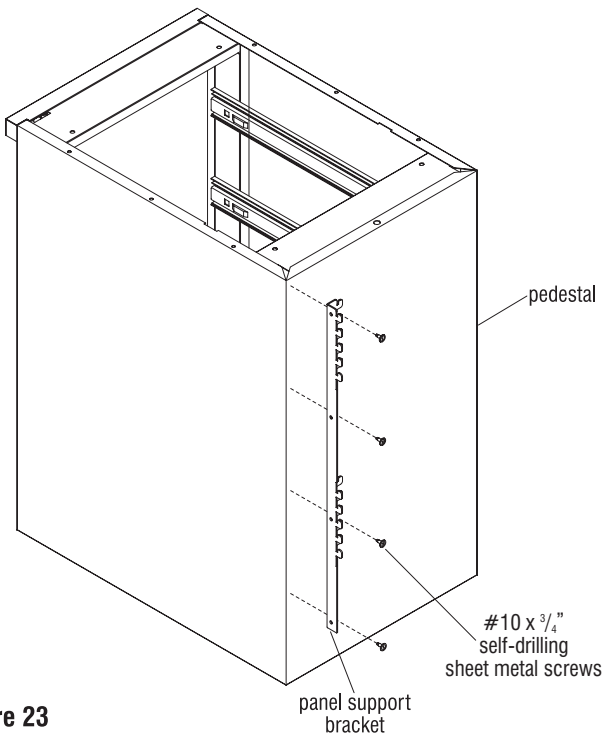

Figure 23

**Panel Support Bracket with No Spacer Installation**

1. Position the panel support bracket squarely along the top and side edge of the pedestal as shown, making sure that the teeth are facing up (Figure 23).

**Caution:** Care should be taken to ensure that the bracket is aligned square with the top and side of the cabinet for cosmetic integrity and safe installation of the worksurface. Laying the cabinet on its side on a smooth clean surface can aid in alignment of the bracket for installation.

**Note:** For left-hand installations align the bracket with the left side of the cabinet. For right-hand installations align the bracket with the right side of the cabinet (Figure 23).

2. Using the four #10 x 3/4" self-drilling sheet metal screws, carefully secure the bracket to the cabinet (Figure 23).

**Panel Support Bracket with Spacer Installation**

1. Position the spacer along the top and side edge of the pedestal as shown (Figure 24).

**Caution:** Care should be taken to ensure that the bracket is aligned well with the top and side of the cabinet for cosmetic integrity and safe installation of the worksurfaces. Laying the cabinet on its side on a smooth clean surface can aid in alignment of the bracket for installation.

**Note:** For left-hand installations align the bracket with the left side of the cabinet with the studs facing right. For right-hand installations flip the bracket over and align the bracket on the right side of the cabinet with the studs facing left.

2. Properly align the spacer to the top and side of the pedestal and use four #12 x 3/4" self-drilling sheet metal screws to secure the spacer to the cabinet (Figure 24).
3. Position the teeth of the panel support bracket face-up and slide the support bracket to the threaded studs on the spacer. Use four 1/4-20 KEPS nuts provided to secure bracket to spacer (Figure 24).

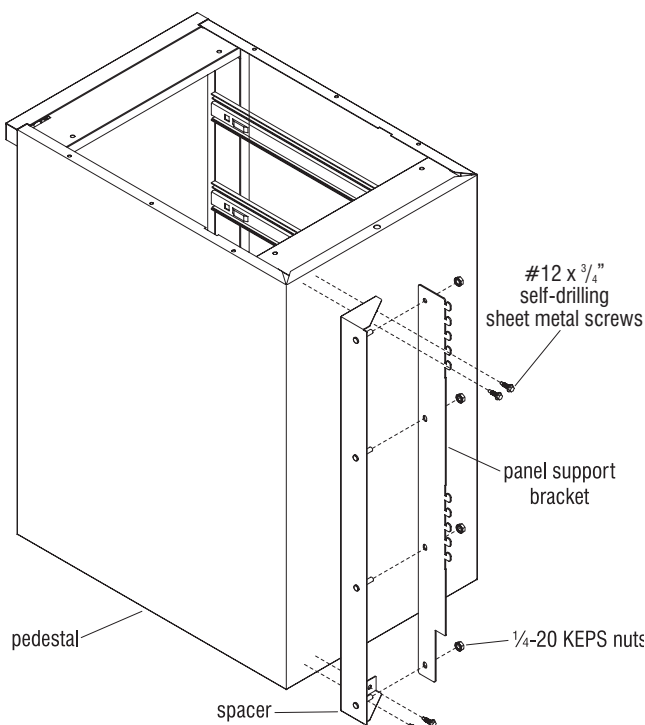

Figure 24

## ■ Unite® Panel System - Worksurface with Pedestal Support Installation

Assembly Instructions



Assemble units as described herein only. To do otherwise may result in instability. All screws, nuts and bolts must be tightened securely and must be checked periodically after assembly. Failure to assemble properly, or to secure parts may result in assembly failure and personal injury.

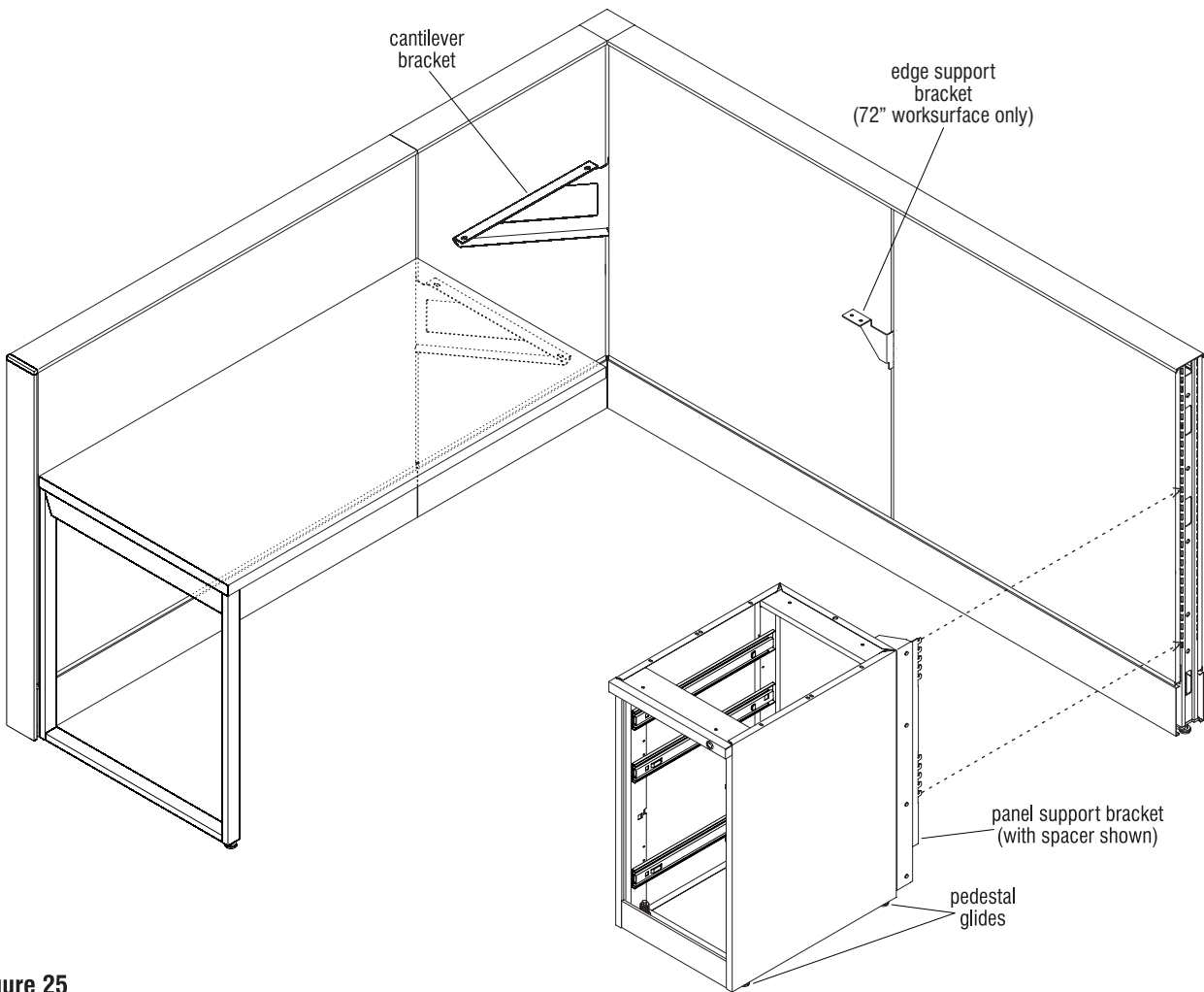

Figure 25

### Typical Corner Intersection with Pedestal Support Installation

**Note:** Cantilever brackets and edge support brackets are used in this typical configuration. Your configuration may vary. Please see pages 58 & 62 for proper installation.

### Pedestal to Panel Installation

**Note:** All pedestals mount to the panel in the same manner, regardless of bracket style.

1. At the location for pedestal installation, move the pedestal to the panel and insert the upward facing teeth of the panel support bracket into the notches in the panel frame.
2. Twist and extend the four glides to raise the pedestal and allow the upward facing teeth of pedestal bracket to engage the panel. This will firmly lock the teeth of the bracket to secure the pedestal to the panel.

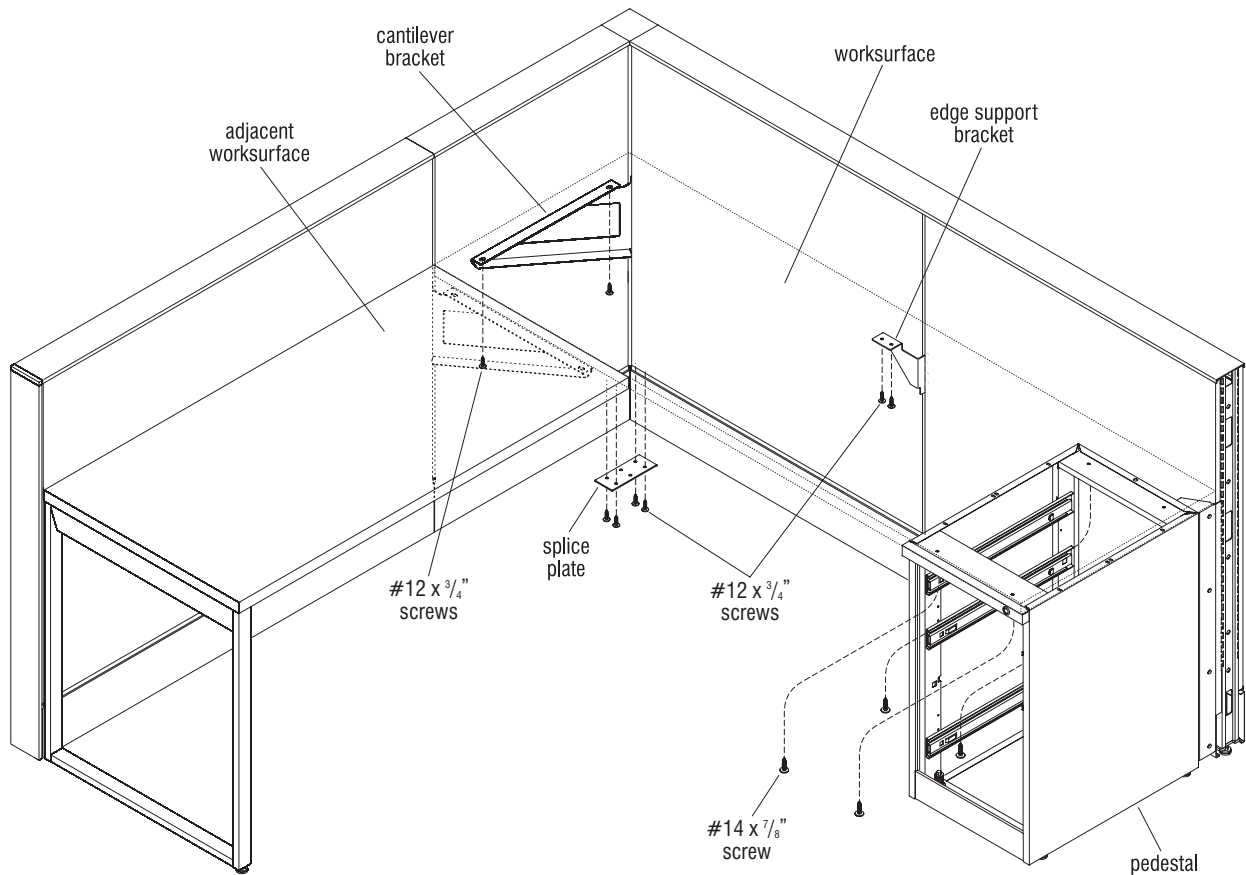
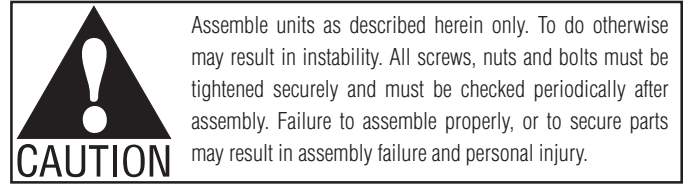

**Figure 26**

3. Carefully place worksurface onto the installed cantilever bracket, support bracket (if used) and the pedestal. Align mounting holes of the installed brackets to pre-drilled holes in underside of worksurface. Secure using two #12 x 3/4" screws per bracket. Take care to not over-tighten screws (Figure 26).

**Note:** If installing a double pedestal (not shown), no holes have been pre-drilled into the underside of the worksurface

for installation. Once the double pedestal is aligned square, use the pedestal mounting holes as a template, and pre-drill using 1/8" drill bit, to depth of 1/2" into underside of worksurface. Take care to not drill too deep.

4. To install pedestal to underside of worksurface, align pre-drilled holes in the worksurface with mounting holes of the pedestal. Take care to assure that the front and side of the pedestal is flush with the edges of the worksurface as illustrated (Figure 26).

**Note:** If a Knife Edge worksurface is being installed, the pedestal will be set back from the front edge of worksurface.

5. Once mounting holes are aligned and cabinet is square, secure pedestal to worksurface using four #14 x 7/8" screws (Figure 26).

6. To keep worksurfaces level, install a small splice plate between adjacent worksurfaces as illustrated. Reference instructions on page 58 for installation (Figure 26).

7. Re-install pedestal drawers by first extending suspensions out of cabinet. Slide the rear slip connection together by aligning the tab of the suspension with the corresponding slot in the drawer body. Hold suspension firmly while pushing the drawer, making sure the slip connection is together properly.

8. With the rear slip connection in place correctly, the front connection tabs will align and the drawer can be pushed down and snapped securely into place.

# Unite® Panel System - Worksurface with Pedestal Support Installation

## Assembly Instructions



Assemble units as described herein only. To do otherwise may result in instability. All screws, nuts and bolts must be tightened securely and must be checked periodically after assembly. Failure to assemble properly, or to secure parts may result in assembly failure and personal injury.

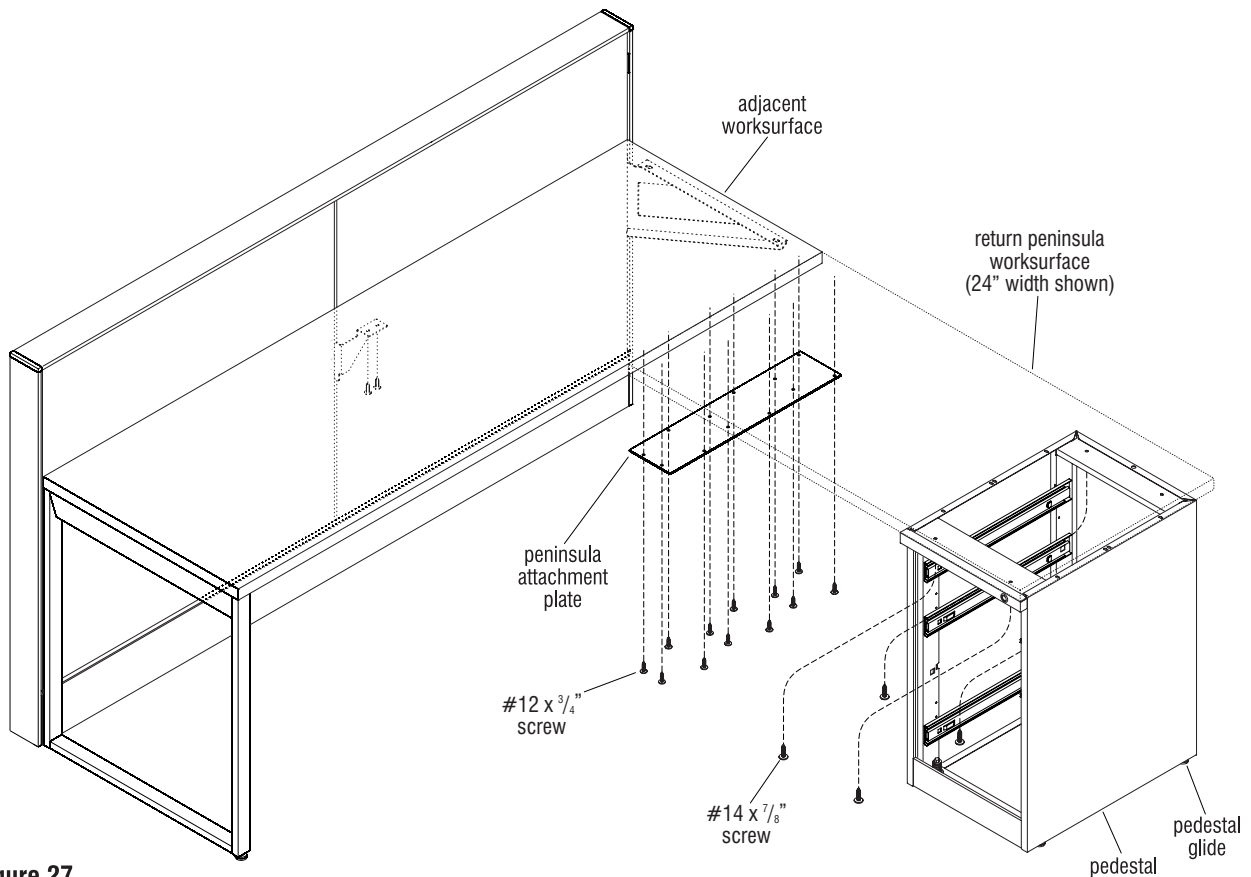

**Figure 27**

### Typical Return Peninsula with Pedestal Support Installation

**Note:** Peninsula worksurfaces are to be less than 72" in length, and are available in 22", 24" and 30" widths, plus 24KN & 30KN widths.

1. Place a peninsula attachment plate under the adjacent worksurface. Center the plate from side-to-side and position the overhang of the plate allowing 2 1/2" for attachment of the peninsula worksurface (Figure 27). Using a pen and the properly positioned attachment plate as a template, mark the center of all attachment hole locations to the underside of the adjacent surface. Remove the plate, and using a drill with 1/8" diameter drill bit, carefully

pre-drill mounting holes to only 1/2" depth in underside of adjacent worksurface. Take care to not drill too deep (Figure 27).

**Note:** 22" and 24" deep peninsula surfaces will use a 21" long peninsula attachment plate and 30" deep surfaces use a 25" long attachment plate. The 21" & 25" mounting plates have a different number of holes. Use all mounting holes to secure.

2. Replace the attachment plate over the pre-drilled holes and secure plate to underside of adjacent worksurface using #12 x 3/4" screws. Take care to not over-tighten screws (Figure 27).
3. Place pedestal to the approximate location it will install under the peninsula worksurface.

Set peninsula worksurface onto pedestal and peninsula attachment plate. Adjust glides on pedestal to level the worksurface and center the worksurface on attachment plate making sure worksurface edges are tight. Take care to not drop or damage the worksurface. Using the attachment plate as a template, pre-drill 1/8" diameter mounting holes to only 1/2" depth in underside of peninsula surface. Take care to not drill too deep (Figure 27).

4. Secure splice plate to peninsula worksurface using #12 x 3/4" screws. Take care not to over-tighten screws (Figure 27).

**Note:** If installing a double pedestal (not shown), no holes are pre-drilled into the underside of the peninsula worksurface for

installation. Once the double pedestal is aligned square, use the pedestal mounting holes as a template, and pre-drill using 1/8" drill bit to depth of 1/2" into underside of worksurface. Take care to not drill too deep.

5. To attach pedestal to underside of worksurface, first align pre-drilled holes of worksurface with mounting holes of pedestal. Check that the front and side of the pedestal is flush with the edges of the worksurface and secure using four #14 x 7/8" screws as illustrated (Figure 27).

**Note:** If a Knife Edge worksurface is being installed, the pedestal will be set back from the front edge of worksurface.

6. Re-install pedestal drawers by following steps 7 & 8, page 75 (previous page).

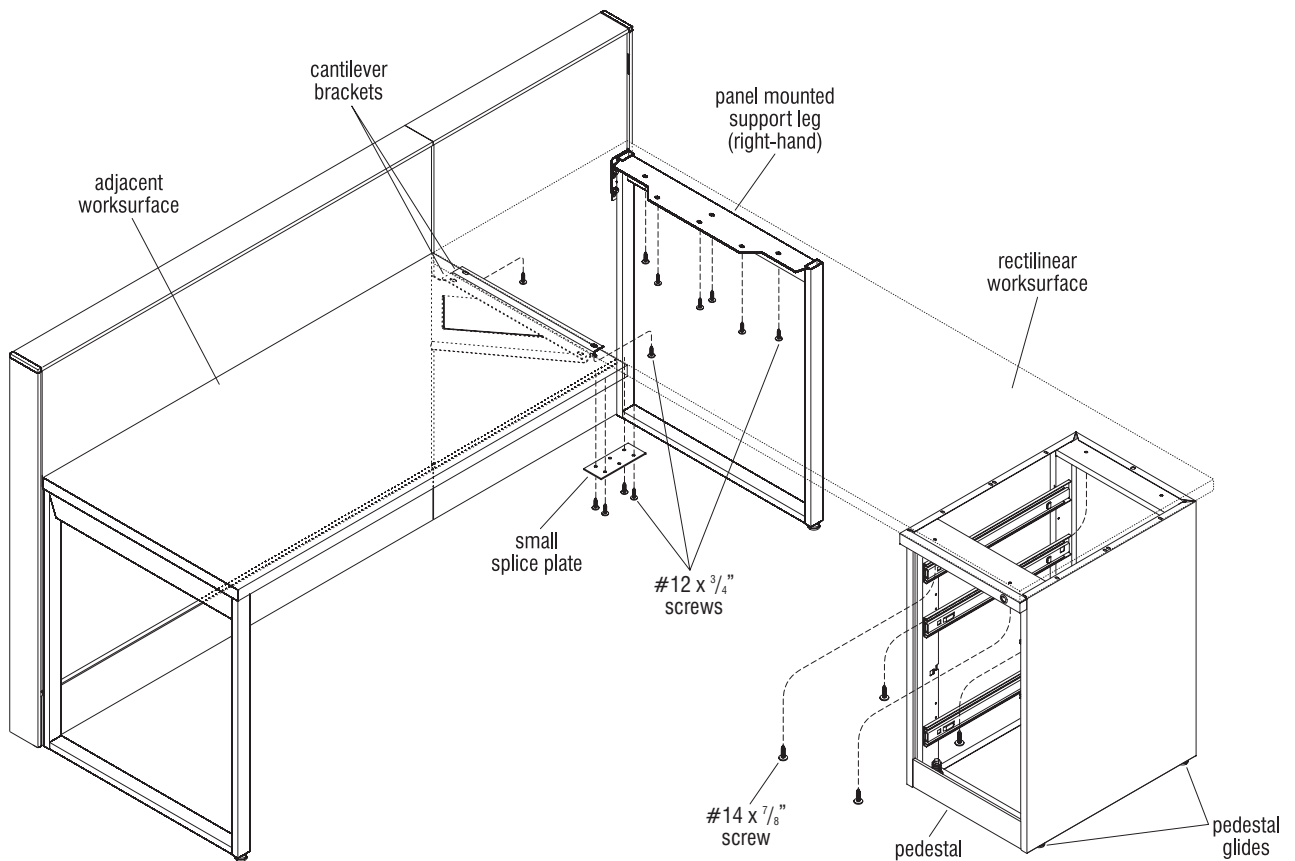
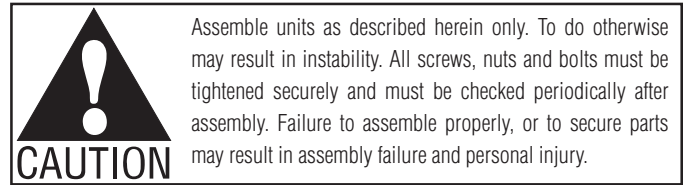

Figure 28

**Typical Rectilinear Worksurface with Adjacent Worksurface and Pedestal Support Installation**

- Carefully place worksurface onto installed cantilever bracket, panel mounted support leg and pedestal then align worksurface to adjacent worksurface as illustrated. Adjust glides under the pedestal to level the rectilinear worksurface. Using the cantilever bracket and support leg mounting holes as a template, pre-drill required mounting holes to 1/8" diameter and 1/2" deep into the underside of the peninsula surface. Take care to not drill too deep (Figure 28).
- Using #12 x 3/4" screws provided, secure the bracket and support leg to the rectilinear worksurface. Take care not to over tighten screws (Figure 28).

**Note:** If installing a double pedestal (not shown), no holes have been pre-drilled into the underside of the peninsula worksurface for installation. Once the double pedestal is aligned square, use the pedestal mounting holes as a template, and pre-drill using a 1/8" drill bit to a depth of 1/2" into underside of worksurface. Take care to not drill too deep.

- To attach the pedestal to the underside of the worksurface, first align the mounting holes of the pedestal to the pre-drilled mounting holes of the rectilinear worksurface. Next, adjust glides on the pedestal to level the worksurface and check that

the front and side of the pedestal is flush with the edges of the worksurface as illustrated (Figure 28).

**Note:** If a Knife Edge worksurface is being installed, the pedestal will be set back 2" from the front edge of worksurface.

- Once aligned, secure pedestal to underside of worksurface using four #14 x 7/8" screws through the pre-drilled holes on each corner of the pedestal (Figure 28).
- To keep worksurfaces level, install a small splice plate between adjacent worksurfaces as illustrated. Reference instruction steps on page 60 for installation (Figure 28).

- Re-install pedestal drawers by first extending suspension out of the cabinet. Slide the rear slip connection together by aligning the tab of the suspension with the corresponding slot in the drawer body. Hold suspension firmly while pushing the drawer, making sure the slip connection is together properly.

- With the rear slip connection in place correctly, the front connection tabs will align and the drawer can be pushed down and snapped securely into place.





KI  
1330 Bellevue Street  
P.O. Box 8100  
Green Bay, Wisconsin 54308-8100  
1-800-424-2432  
[www.ki.com](http://www.ki.com)

KI is a registered trademark  
of Krueger International, Inc.

© 2016 Krueger International, Inc.  
All Rights Reserved  
Code KI-62383R4/KI/PDF/1116

