



## Universal Dimming Module



# CONTENTS

<b>INTRODUCTION .....</b>	<b>2</b>
Welcome	2
Safety	2
Optional extras	3
<b>INSTALLATION .....</b>	<b>4</b>
Opening and closing the casing	4
Making connections	5
Inputs	5
Offset adjustment	5
Outputs	6
<b>CONFIGURATION .....</b>	<b>7</b>
0-10V to mains dimming	7
DMX to mains dimming	8
0-10V to DMX	9
DMX to 0-10V	10
0-10V sink to 0-10V source	11
Switch settings	12
RDM settings	13
<b>FURTHER INFORMATION .....</b>	<b>14</b>
Specifications	14
Dimensions	15
Limited product warranty	16

# INTRODUCTION

## WELCOME

Welcome to the Universal Dimming Module or *UDM* from Acclaim Lighting. The UDM is effectively a problem solving device, designed to 'fill the gap' between differing control methods in your lighting installation. The UDM can accept various inputs and convert them into the required output:

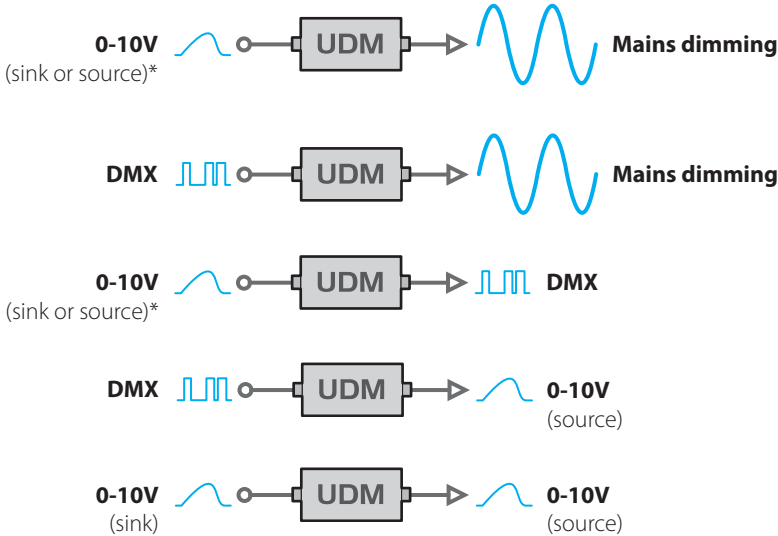

The UDM houses a mains dimmer based upon an Insulated Gate Bipolar Transistor (IGBT) to deliver mains dimming for loads up to 1000W.

The UDM is configured using a combination of internal switches and/or Remote Device Management (RDM) via the DMX interface. See page 12 and page 13 for details.

## SAFETY

- Ensure that the power input is supplied from a correctly fused, grounded and environmentally protected location.
- The casing has mains components close to the edges, particularly at the input end where the fuse is exposed. Exercise great care if configuring the unit while power is applied.

*\* Note: There are two forms of 0-10V analog control: **Current source** and **current sink**. The former was commonly used for theatrical dimming prior to the advent of digital techniques, such as DMX; the latter is used mainly as a control technique for fluorescent dimming ballasts. The primary difference between the two schemes lies with where the control voltage should be generated: **Current source** requires the controlling device to provide (source) the control voltage; whereas **Current sink** mandates that the controlled fixture must provide the voltage. The AL Driver 800 supports the **current source** variant (ESTA E1.3) only.*

*The UDM can accept either variant of 0-10V signal as an input and can be configured to produce a **current source** output in response. See page 11 for details.*

## OPTIONAL EXTRAS

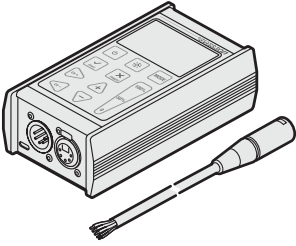

**DMX/RDM tool plus male 5pin XLR lead**

[XMT350]

# INSTALLATION

The UDM can be fixed in any orientation to suitable mounting surfaces. There are Ø0.201" (Ø5mm) mounting holes in each corner of the integral end brackets (see page 15 for dimensions). When the foam seals are correctly in place at each end of the casing, the UDM achieves ingress protection to IP64 (damp location). To fully comply, however, ensure that all external connections are made within suitable 3rd party IP-rated junction boxes. The cable access holes at each end are terminated with ½" conduit glands.

## OPENING AND CLOSING THE CASING

Access is gained by removing one or both of the end brackets. All input connections are based at one end, while all outputs (and the configuration switches) are located at the other - see the front panel label for details.

### TO OPEN THE CASING

**IMPORTANT: If the UDM has already been installed and used, ensure the power supply is fully isolated before opening.**

- 1 At the appropriate end, remove the four screws that hold the end bracket in place:

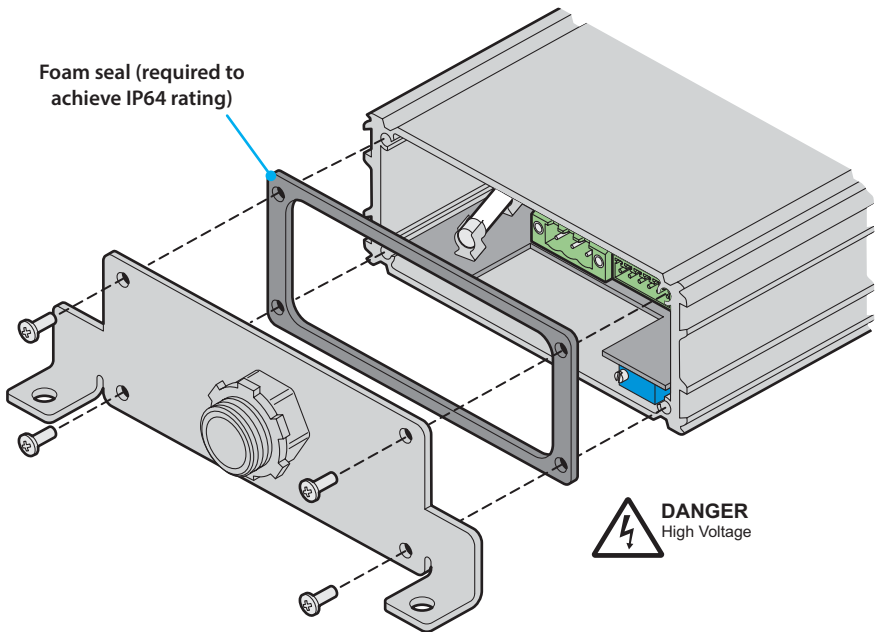

- 2 Safely store the screws and the foam seal for re-installation later.

### TO CLOSE THE CASING

- 1 Secure and check all connections.
- 2 Carefully place the end bracket and foam seal against the end of the chassis - ensure that the seal is correctly positioned.
- 3 Insert and tighten the four screws.
- 4 Make the required conduit connection to the cable gland.
- 5 Repeat steps 1 to 4 at the other end.
- 6 Mount the UDM, as required.

## MAKING CONNECTIONS

The UDM houses all inputs at one end and all outputs (plus the configuration switches) at the other.

### INPUTS

At the Input end of the UDM casing, there are the following items:

- Mains power input (100 to 277VAC 50/60Hz)
- Mains fuse (Ø6.3 x 32mm - F15A/500VP - ceramic fast blow)
- DMX digital control input
- 0-10V analog control input
- 0-10V offset adjustment

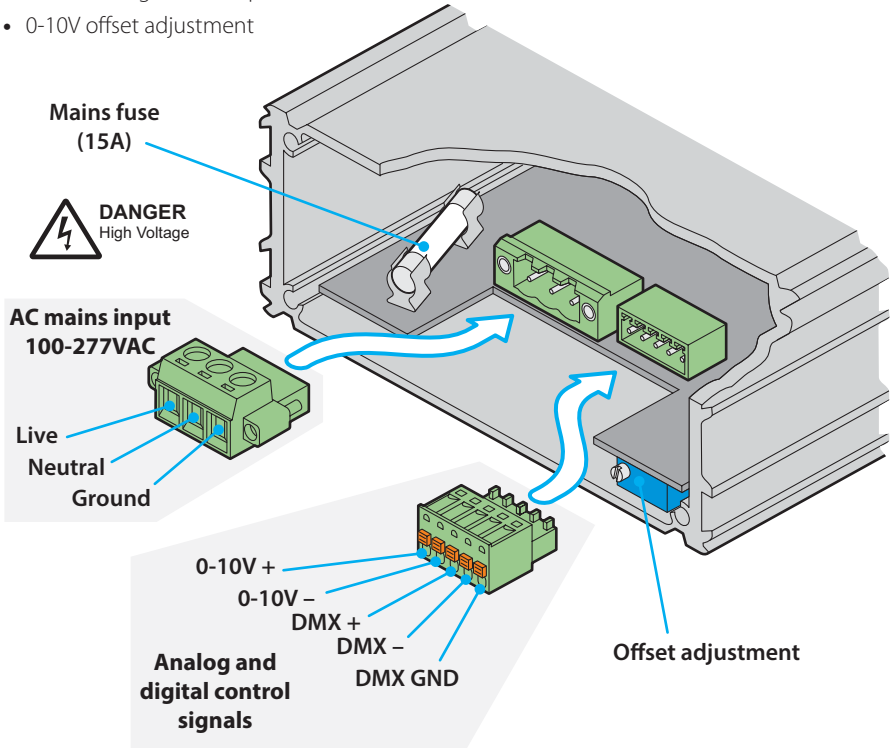

### OFFSET ADJUSTMENT

The small offset adjuster allows you to match the mains dimming level with the control input. The adjuster increases dimmed output when it is turned counter clockwise.



**IMPORTANT:** This procedure requires the casing to be open while mains is applied. The UDM has mains components close to the edges, particularly at the input end where the fuse is exposed.

### TO ADJUST

- 1 Connect a DMX or 0-10V control input and a mains dimmed load.
- 2 Set the control input to zero and adjust the offset screw clockwise until the connected load has no output.

## OUTPUTS

At the Output end of the UDM casing, there are the following items:

- Mains hot and dimmed power outputs
- DMX digital control output
- Dual 0-10V analog control outputs
- Configuration switches

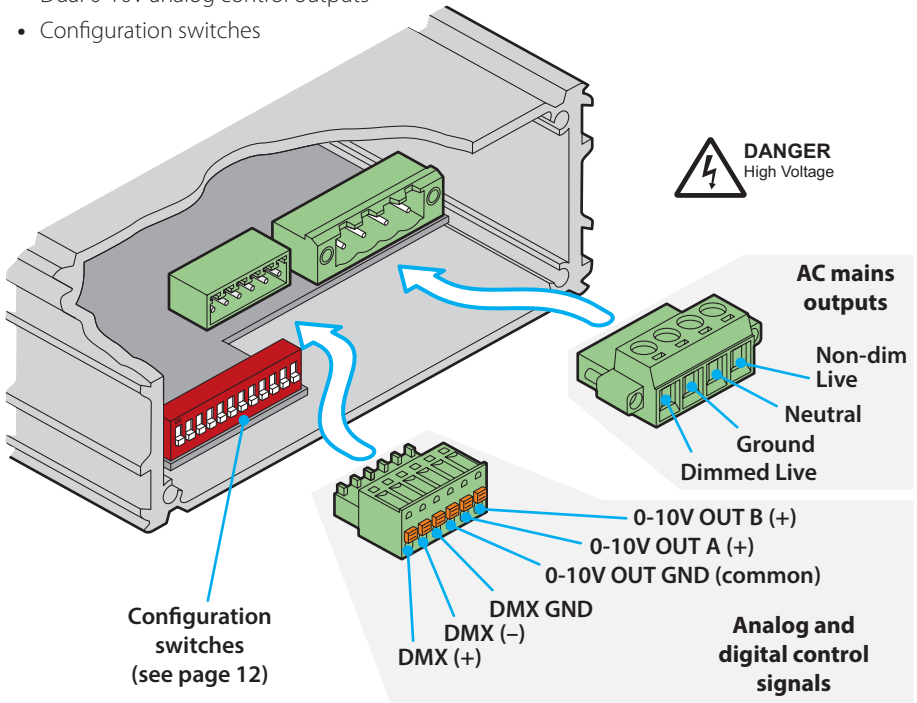



# CONFIGURATION

This chapter provides connection and configuration details for each of the five main uses of the UDM.

## 0-10V TO MAINS DIMMING

In this mode the 0-10V (sink or source) input determines the level of output from the in-built mains dimmer unit. The dimmed mains output at 100% will match that of the mains input, which can be in the range 100 to 277VAC 50/60Hz.

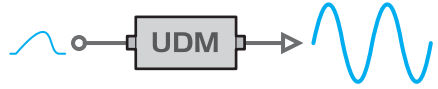

### REQUIRED CONNECTIONS

The required connections are as follows:

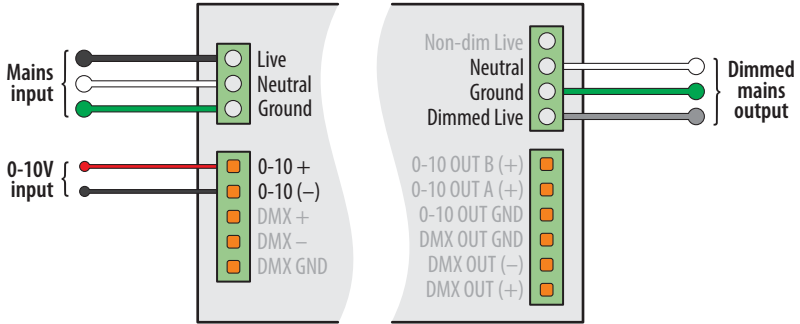

### SWITCH SETTINGS

The switch settings allow you to configure a base setting for the UDM. If required, certain switch settings can be overridden using RDM. The relevant switch settings for this configuration are:

- Switch 10: **OFF** - 0-10V Input
- Switch 11: **ON** - Dimmable AC On

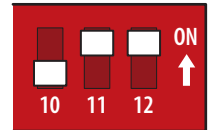

*Note: Optionally, to achieve smoother dimming, set switch 12 to ON (see page 12)*

*Note: No address is required for 0-10V operation*

### RDM CONFIGURATION

Using RDM, via the DMX input, you can alter the DMX address and mode of operation. Any changes made will override the switch settings. For full details about RDM, see page 13.

*Note: The DMX input remains active, even when 0-10V mode is selected, to allow RDM configuration.*

▶ LABEL:	UDM 0
MODEL:	
MAN:	ACCLAIM LIGHTING
DMX START ADDRESS:	001
DMX PERSONALITY:	DMX+IGBT
DMX SLOTS:	1

	000 CH
001:	DMX
002:	DMX+IGBT
003:	ZTEN
● 004:	ZTEN+IGBT

Choose the mode of operation here: **ZTEN+IGBT** for 0-10V controlled mains dimming

### OTHER NOTES

The DMX and dual 0-10V outputs are also active in this mode (matching the input signal) and can be used alongside the dimmed mains output. The non-dim live output is also available for pass-through to power fixtures (the combined dimmed and non-dim loads must not exceed the stated maximum for the UDM as a whole).

## DMX TO MAINS DIMMING

In this mode the DMX input determines the level of output from the in-built mains dimmer unit. The dimmed mains output at 100% will match that of the mains input, which can be in the range 100 to 277VAC 50/60Hz.

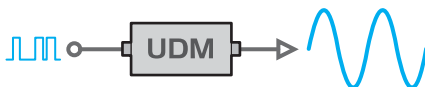

### REQUIRED CONNECTIONS

The required connections are as follows:

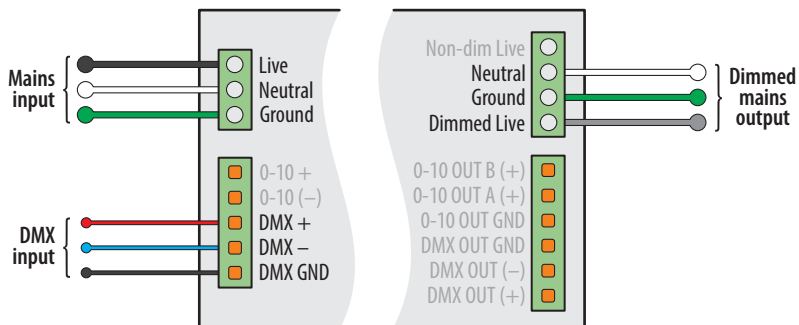

### SWITCH SETTINGS

The switch settings allow you to configure a base setting for the UDM. If required, certain switch settings can be overridden using RDM. The relevant switch settings for this configuration are:

- Switches 1 to 9: *DMX address* (see page 12)
- Switch 10: **ON** - *DMX Input*
- Switch 11: **ON** - *Dimmable AC On*

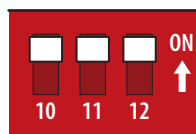

*Note: Optionally, to achieve smoother dimming, set switch 12 to ON (see page 12)*

### RDM CONFIGURATION

Using RDM, via the DMX input, you can alter the DMX address and mode of operation. Any changes made will override the switch settings. For full details about RDM, see page 13.

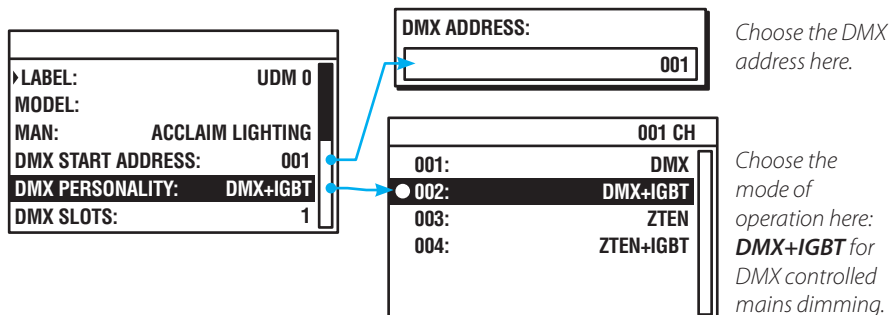

### OTHER NOTES

The DMX and dual 0-10V outputs are also active in this mode (matching the 0-10V input signal) and can be used alongside the dimmed mains output. The non-dim live output is also available for pass-through to power fixtures (the combined dimmed and non-dim loads must not exceed the stated maximum for the UDM as a whole).

## 0-10V TO DMX

In this mode, the dimming range of the 0-10V (sink or source) input is converted into a DMX output signal, ranging in value from 0 to 255. The DMX output is delivered at the channel address determined by the switches and/or RDM configuration.



### REQUIRED CONNECTIONS

The required connections are as follows:

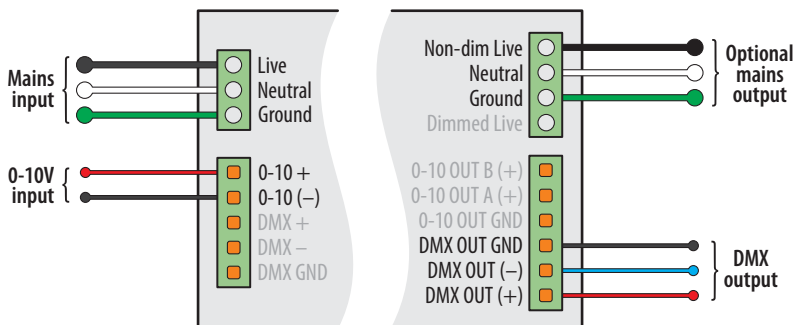

### SWITCH SETTINGS

The switch settings allow you to configure a base setting for the UDM. If required, certain switch settings can be overridden using RDM. The relevant switch settings for this configuration are:

- Switches 1 to 9: *DMX address* (see page 12)
- Switch 10: **OFF** - 0-10V Input
- Switch 11: **OFF** - Dimmable AC Off



### RDM CONFIGURATION

Using RDM, via the DMX input, you can alter the DMX address and mode of operation. Any changes made will override the switch settings. For full details about RDM, see page 13.  
*Note: The DMX input remains active, even when 0-10V mode is selected, to allow RDM configuration.*

▶ LABEL:	UDM 0
MODEL:	
MAN:	ACCLAIM LIGHTING
DMX START ADDRESS:	001
DMX PERSONALITY:	DMX+IGBT
DMX SLOTS:	1

DMX ADDRESS:	001
--------------	-----

Choose the DMX address here.

001 CH	
● 001:	DMX
002:	DMX+IGBT
003:	ZTEN
004:	ZTEN+IGBT

Choose the mode of operation here: **DMX** for 0-10V to DMX conversion.

### OTHER NOTES

The non-dim live output is available for pass-through to power fixtures. The non-dim load must not exceed the stated maximum for the UDM.

## DMX TO 0-10V

In this mode, the DMX input is converted into a 0-10V (source) output signal with voltage values in accordance with the input range of 0 to 255. The DMX input is taken from the address determined by the switches and/or RDM configuration.



### REQUIRED CONNECTIONS

The required connections are as follows:

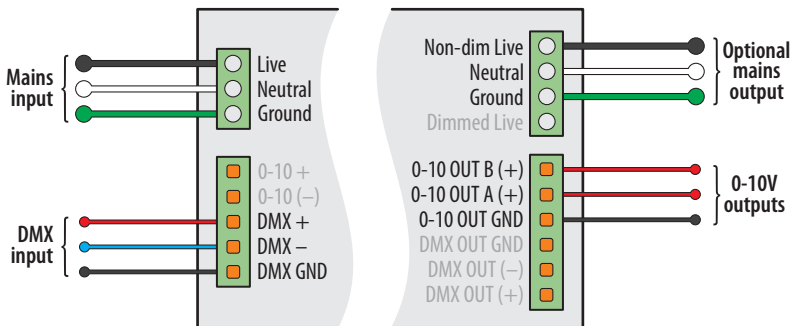

### SWITCH SETTINGS

The switch settings allow you to configure a base setting for the UDM. If required, certain switch settings can be overridden using RDM. The relevant switch settings for this configuration are:

- Switches 1 to 9: *DMX address* (see page 12)
- Switch 10: **ON** - *DMX Input*
- Switch 11: **OFF** - *Dimmable AC Off*

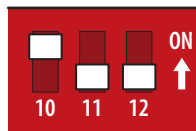

### RDM CONFIGURATION

Using RDM, via the DMX input, you can alter the DMX address and mode of operation. Any changes made will override the switch settings. For full details about RDM, see page 13.

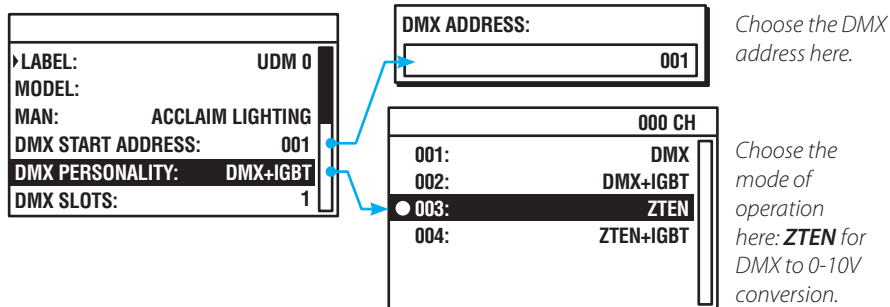

### OTHER NOTES

The non-dim live output is available for pass-through to power fixtures. The non-dim load must not exceed the stated maximum for the UDM.

## 0-10V SINK TO 0-10V SOURCE

In this mode, the 0-10V sink input is converted into a corresponding 0-10V source output signal. The single input is replicated on two outputs, which can be fed to different devices.



### REQUIRED CONNECTIONS

The required connections are as follows:

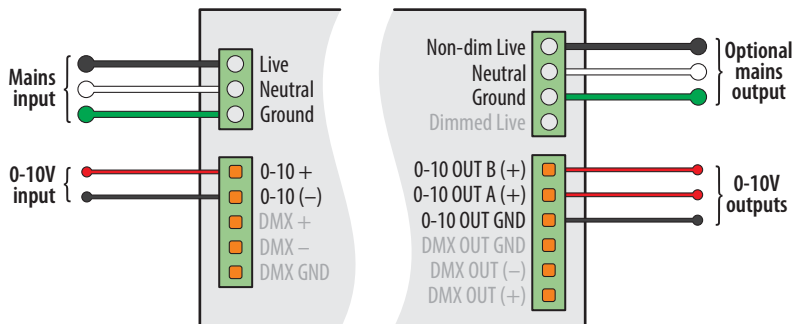

### SWITCH SETTINGS

The switch settings allow you to configure a base setting for the UDM. If required, certain switch settings can be overridden using RDM. The relevant switch settings for this configuration are:

- Switch 10: **OFF** - 0-10V Input
- Switch 11: **OFF** - Dimmable AC Off

*Note: No address is required for 0-10V operation.*



### RDM CONFIGURATION

Using RDM, via the DMX input, you can alter the DMX address and mode of operation. Any changes made will override the switch settings. For full details about RDM, see page 13.

▶ LABEL:	UDM 0
MODEL:	
MAN:	ACCLAIM LIGHTING
DMX START ADDRESS:	001
DMX PERSONALITY:	DMX+IGBT
DMX SLOTS:	1

000 CH	
001:	DMX
002:	DMX+IGBT
● 003:	ZTEN
004:	ZTEN+IGBT

*Choose the mode of operation here: ZTEN for 0-10V to 0-10V conversion.*

### OTHER NOTES

The non-dim live output is available for pass-through to power fixtures. The non-dim load must not exceed the stated maximum for the UDM.

## SWITCH SETTINGS

The switch block, located at the output end, is used to configure the basic elements of the UDM. Most of the switch settings can be optionally overridden later using RDM commands issued through the DMX input, removing the need to open the casing once fitted.

*Note: The switch block is only consulted when the UDM is powering on, so a power reset will be needed whenever changes are made.*

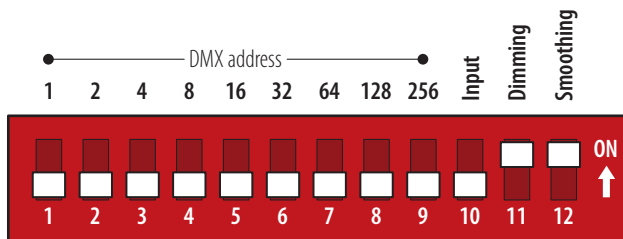

- Switches 1 to 9: **DMX base address**
- Switch 10: **Input mode**

OFF	0-10V input
ON	DMX input
- Switch 11: **Dimming**

OFF	Mains dimming disabled
ON	Mains dimming enabled
- Switch 12: **Smoothing**

OFF	Dim smoothing disabled
ON	Dim smoothing applied to mains output

*Smoothing helps to eradicate any visible stepping between dimmed mains levels by adding intermediate values between the 255 (8-bit) steps.*

## CONFIGURATION EXAMPLE

To configure the UDM for the following:

- *DMX address: 35*
- *DMX input enabled*
- *Mains dimming enabled*
- *Dim smoothing enabled*

The switch block would need to be configured like this:

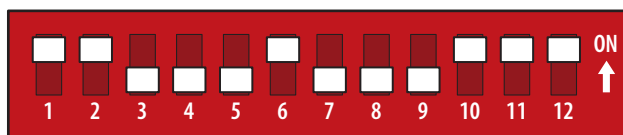

## RESETTING THE SWITCH BLOCK

Once an RDM configuration is sent to the UDM, it remains dominant. To clear all RDM input, dimming and smoothing settings, set switches 10 to 12 OFF and then cycle the power input. To clear the DMX address, do the same with switch 1 to 9.

## RDM SETTINGS

The use of RDM (Remote Device Management) with the UDM is optional but offers the great advantage of allowing configuration changes to be made without the need to open the casing. The following items can be configured via RDM:

- DMX address
- DMX input mode
- Mains dimming mode

Various third party DMX/RDM tools are available; Acclaim Lighting recommends the XMT-350 for this task.

### TO CONFIGURE THE UDM USING AN XMT-350

- 1 Connect the XMT-350 to the DMX input line of the UDM and power on both.
- 2 On the XMT-350, press the **MODE** button, then use the arrow buttons to highlight the **RDM** function and press the  button to select. The XMT-350 will search for RDM devices and after a short while the XMT-350 will display a list of all located fixtures:

MAIN PATCH OPTIONS	001/001
UDM	001

*Note: The UDM does not flash its outputs to identify itself.*

- 3 On the XMT-350, with the **MAIN** tab highlighted, press the  button to display the main configuration screen:

UDM 0	
LABEL:	UDM 0
MODEL:	
MAN:	ACCLAIM LIGHTING
DMX START ADDRESS:	001
DMX PERSONALITY:	DMX+IGBT
DMX SLOTS:	1

- 4 If required, highlight **DMX START ADDRESS**, press the  button and set the DMX address.
- 5 To change the operation mode, highlight **DMX PERSONALITY** and press the  button:

001 CH	
001:	DMX
● 002:	DMX+IGBT
003:	ZTEN
004:	ZTEN+IGBT

*Note: The ● marker indicates which mode is currently configured within the UDM.*

- 6 Highlight the required option:
  - **DMX** - Enables DMX input but disables mains dimming.
  - **DMX+IGBT** - Enables DMX input and routes received values to the mains dimming.
  - **ZTEN** - Enables 0-10V input but disables mains dimming.
  - **ZTEN+IGBT** - Enables 0-10V input and routes received values to the mains dimming.
- 7 Press the  button to send the command to the UDM.
- 8 Press the  button to return to the main configuration screen.

# FURTHER INFORMATION

## SPECIFICATIONS

Input voltage range	100-277VAC, 50/60Hz
Output voltage	As per input
Power rating	1000W maximum
Input protocols	DMX + RDM, 0-10V (source or sink)
Output protocols	DMX + RDM, 0-10V, IGBT digital line voltage dimming
AC supply options	100-277V pass through
Configuration	Via on-board switches and/or RDM
Dim Smoothing	Available via dip switch setting
0-10V sink power	Up to 25mA
Housing material	Aluminum
Finish	Black
IP Rating	IP64, Damp Location - Connections to be made in 3rd party junction box or conduit
Operating Temperature	-31° F to 122° F (-35° C to 50° C)

### Certifications





# DIMENSIONS

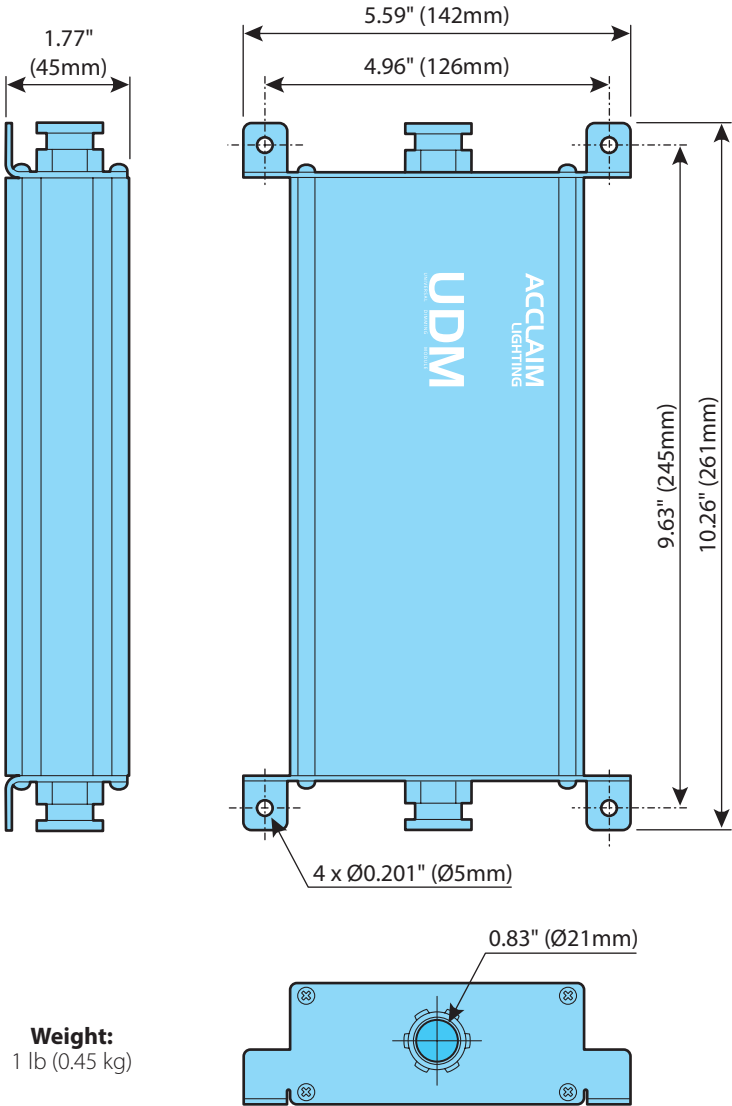

**Weight:**  
1 lb (0.45 kg)

## LIMITED PRODUCT WARRANTY

A. Acclaim Lighting™ hereby warrants, to the original purchaser, Acclaim Lighting finished products to be free of manufacturing defects in material and workmanship for a standard period of:

- Fixtures: 5 Years (1,825 days) from the date of purchase.
- Drivers, power supplies and accessories: 5 Years (1,825 days) from the date of purchase.
- Flex Products: 3 Years (1,095 days) from the date of purchase.
- Controllers: 2 Years (730 days) from the date of purchase.

It is the owner's responsibility to establish the date and place of purchase and warranty terms by acceptable evidence, at the time service is sought.

B. For warranty service, send the product only to the Acclaim factory. All shipping charges must be pre-paid. If the requested repairs or service (including parts replacement) are within the terms of this warranty, Acclaim Lighting will pay return shipping charges only to a designated point within the United States. If the entire instrument is sent, it must be shipped in its original package. No accessories should be shipped with the product. If any accessories are shipped with the product, Acclaim Lighting shall have no liability whatsoever for loss of or damage to any such accessories, nor for the safe return thereof. Acclaim reserves the right to replace the item with same or similar product at its discretion.

C. This warranty is void if the serial number has been altered or removed; if the product is modified in any manner which Acclaim concludes, after inspection, affects the reliability of the product; if the product has been repaired or serviced by anyone other than the Acclaim Lighting factory unless prior written authorization was issued to purchaser by Acclaim Lighting; if the product is damaged because not properly maintained as set forth in the instruction manual.

D. This is not a service contract, and this warranty does not include maintenance, cleaning or periodic check-up nor do we guarantee as part of this warranty any lumen performance during period. Parts not covered by this warranty include: fuses, external power supplies, third party items not manufactures by Acclaim lighting. During the period specified above, Acclaim Lighting will replace defective parts at its expense, and will absorb all expenses for warranty service and repair labor by reason of defects in material or workmanship. The sole responsibility of Acclaim Lighting under this warranty shall be limited to the repair of the product, or replacement thereof, including parts, at the sole discretion of Acclaim Lighting. At no time will installation or re-installation or products labor or liability costs will be assumed by Acclaim Lighting. All products covered by this warranty were manufactured after January 1, 2012, and bear identifying serial number marks to that effect.

E. Acclaim Lighting reserves the right to make changes in design and/or improvements upon its products without any obligation to include these changes in any products theretofore manufactured. No warranty, whether expressed or implied, is given or made with respect to any accessory supplied with products describe above. Except to the extent prohibited by applicable law, all implied warranties made by Acclaim Lighting in connection with this product, including warranties of merchantability or fitness, are limited in duration to the warranty period set forth above. And no warranties, whether expressed or implied, including warranties of merchantability or fitness, shall apply to this product after said period has expired.

F. Marine or extreme weather location applications using Acclaim lighting products are subject to a 2 year limited warranty and Acclaim must be notified prior to delivery of units for such applications so that preventative treatment can be made to the products to ensure proper performance and product life with a special marine code coating / sealing process at an additional cost.

G. The consumer's and or dealer's sole remedy shall be such repair or replacement as is expressly provide above; and under no circumstances shall Acclaim Lighting be liable for any loss or damage, direct or consequential, arising out of the use of, or inability to use, this product. This warranty is the only written warranty applicable to Acclaim Lighting products and supersedes all prior warranties and written descriptions of warranty terms and conditions heretofore published.



[www.acclaimlighting.com](http://www.acclaimlighting.com)