

SUBMITTAL SHEET

BOX SERIES

Project Name _____

Specification Section _____

Ceiling Type _____

Return Form To Hunter Douglas
E-mail: ceilings@hunterdouglas.com
Fax: 770-806-0214

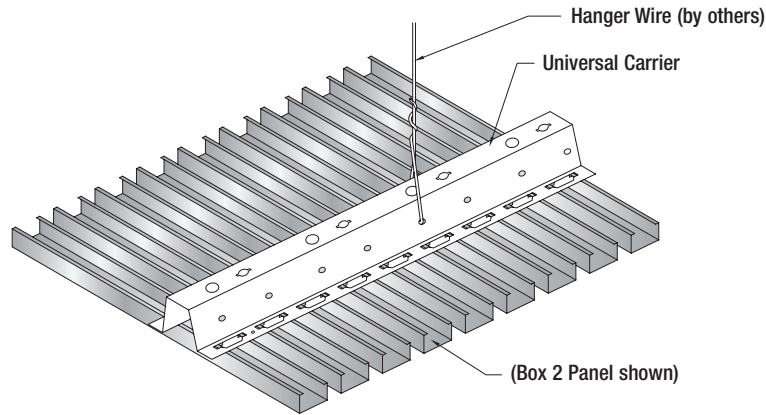
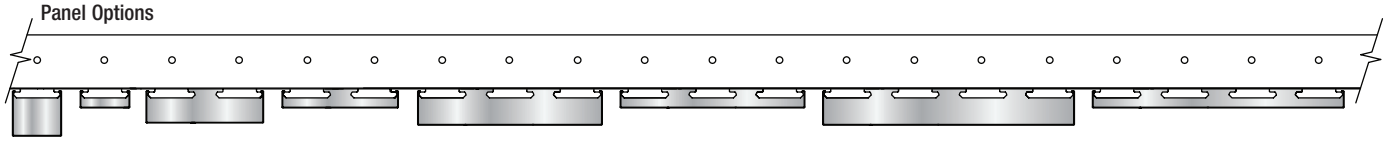

SUBSTRATE:
ALUMINUM

Box Series 2" _____ 4" _____ 6" _____ 8" _____ (If multiple, select all that apply)

COLOR/FINISH

Cotton White – #0280 Veneer _____ Other _____
 Natural – #7163 Decorated _____

FILLER STRIP

Box Flat Recessed Closure – Matte Black – #1883 Butterfly – Matte Black – #1883
 Box Flat Recessed Closure – Cotton White – #0280 Butterfly – Cotton White – #0280

PERFORATION
PATTERN

Box 2 Non-Perforated Box 6 Non-Perforated #124
Box 4 Non-Perforated #124 Box 8 Non-Perforated #124

ACOUSTICAL
RATING

(NRC) _____

TRIM

Wall Angle J Trim
 Floating End Caps

EXPOSURE

Interior
 Exterior (specify design wind pressure) _____ PSF

SHOP DRAWINGS
ATTACHED?

Yes No

To Contact Us:
5015 Oakbrook Parkway, Suite 100
Norcross, GA 30093
phone: 800.366.4327
fax: 770.806.0214
www.hunterdouglascontract.com/ceilings

HunterDouglasContract

CEILINGS

PERFORATIONS

Perforated panels improve acoustical performance as well as create aesthetic effects.

#124

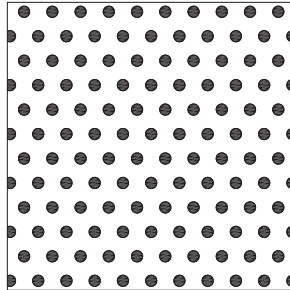

Perforation diam: .078 in.
Open area: 15%
(Box 4, 6, 8)

SOUND ABSORPTION (NRC) SUMMARY*

Sound absorption can be achieved by the addition of backing ceiling panels with acoustical fabric or pad.

Perforation Pattern	% Open Area	Acoustical Infill	NRC
#124	15%	1.5" - 1.5 pcf Polywrapped Fiberglass	1.00

* Acoustical tests performed in accordance with ASTM C423 and ASTM E795, in a type E400 mounting. Test reports available upon request.

TESTING RESULTS

Surface Burning	Class A (ASTM E84) Flame \leq 25 Smoke \leq 50	IAQ Friendly	Yes – Mold & Mildew Resistant
Light Reflectance	LR1 (White)	VOCs	No
Stability under humidity	Yes	Fiber Content	No
		Moisture Resistance	Excellent
		Life Cycle	Excellent

SUSTAINABILITY

Hunter Douglas aluminum ceilings are manufactured from material with a minimum of 70% recycled content

- 40% is post-consumer
- 30% is pre-consumer

