

FRÍANT

# TILES

PRICE BOOK  
effective October 2013





# Table of Contents

Terms and Conditions.....	2
Standard Fabrics and Finishes .....	4
Tile Application .....	5

## FRAMES

Non-Powered Frames .....	6
Powered Frames with Duplex Cutouts.....	8
Powered Frames Power and Data with Duplex Cutouts .....	10
Stacking Frames / Draw Nut.....	12
Door Frames.....	13

## CONNECTORS

Draw Rod .....	14
Connectors.....	15
Stacking Connectors .....	18
Wall Strip.....	21
Tile Adapter .....	21
Finished End.....	22
Finished End Change of Height.....	22
Wall Start.....	22
Change of Height Wedge .....	23
Connector Covers .....	24

## TILES

Fabric Covered Tiles .....	28
Beltline Power Access Tile.....	30
Window Tile .....	31
Open Tile.....	32
Perforated Metal Tile .....	34
Rail Tile.....	35
Tool Bar.....	36
Markerboard Tile.....	37

## ELECTRICAL DISTRIBUTION

Base Power Entry Direct Connect, 4-circuit .....	38
Ceiling Power Entry Internal Direct Connect 4-circuit.....	38
Receptacle 4-circuits .....	39
Ceiling Data Entry Non-powered.....	39
Pass-Through Festoon 23" Long 4-circuit	39
Beltline Power Retro.....	40
In Frame Power Jumper .....	40
Pass-Through Power Jumper .....	40
Beltline Power Transfer .....	41
Data Port Plate.....	41

## WORKSURFACES

Rectangular Worksurface .....	42
Rectangular Worksurface Connector Spanning .....	43
90° Notched and Curved Worksurface.....	44
Square Edge Half Circle Worksurface.....	45
Square Edge D-Shaped Peninsula Worksurface.....	46
90° Extended Notched Corner Worksur- face.....	47
90° Extended Curved Corner Worksurface.....	50
90° Extended Notched Corner Peninsula Worksurface.....	53
Extended Curved Corner Peninsula Worksurface.....	57
Extended Curved Corner P-Shape Penin- sula Worksurface.....	61
Elipse End Peninsula Worksurface .....	63
Rectangular Asymmetrical Worksurface.....	64
120° Rectangular Worksurface.....	65
120° Corner Worksurface 90° Ends .....	66
120° Corner Worksurface 120° Ends .....	67
135° Corner Worksurface.....	68
135° Double Corner Worksurface.....	69
Rectangular Transaction Worksurface .....	70
Corner Transaction Worksurface.....	71
Racetrack Transaction Worksurface .....	72

## WORKSURFACE SUPPORT

Custom Transaction Worksurface Support .....	73
Flat Bracket.....	74
Supports.....	75

## COMPONENTS

"B" Style Shelf Half Height.....	77
"B" Style Shelf Full Height .....	77
"B" Style Locking Fabric Flipper Unit .....	78
"B" Style Locking Painted Flipper Unit.....	78
Frameless Glass .....	79
Frameless Glass Change of Height.....	80
Tasklight.....	81
Wire Manager.....	81
Pencil Drawer .....	81

## STORAGE

Pedestals .....	82
Laterals.....	84

## ACCESSORIES

Tool Bar .....	86
Flat Paper Tray .....	86
Vertical Single Tray.....	86
Vertical Triple Tray .....	86
Carpet Gripper .....	86
Keyed-Alike .....	87

---

## Terms and Conditions

### PRICES

All Prices are F.O.B. destination. We reserve the right to change prices without prior notice.

### ORDERING

Purchase Orders should be sent to Friant & Associates, LLC at orders@friant.com, or faxed to (510) 535-6895. If your specifications were created with CAP, GIZA or Project Matrix, please send the worksheet (SP4) with your Purchase Order.

### TERMS

Net 30 days from date of invoice. Invoices are delinquent if not paid 30 days from date of invoice. In the event timely payment is not made, interest will be charged at the rate of 1.5% per month on delinquent accounts. Buyers will also be liable for normal collection costs and attorney's fee. 50% deposit is required with every order, unless prior arrangements have been made.

### LEAD TIME

Lead times subject to availability.

### ORDERS

Orders are only accepted by issuance of our formal acknowledgment, and are subject to the terms set forth herein and on our order acknowledgment. It is the responsibility of the buyer to review our acknowledgment for its accuracy, and to notify Friant within 48 hours from the date of the acknowledgment of any discrepancies.

### SHIPPING

Friant generally palletizes, boxes and/or shrink-wraps its products. If buyer requests additional packaging or special shipping, then it is responsible for any extra costs that result. Buyer obtains title to products and assumes the risk of loss for them upon shipment from Friant's plant.

### CLAIMS

We are not responsible for damage suffered in transit. Merchandise should be inspected for possible freight damage upon delivery. The consignee should file for damage or shortages with the carrier within 5 days of delivery. You are also protected for "concealed damage" if you file claim with the carrier within 5 days of delivery. Buyer must make all claims against Friant for defects, errors or shortages in writing within 10 days after delivery. Failure to make such a claim shall constitute full acceptance.

### RETURNS

No merchandise may be returned without our written consent and shipping instructions. Unauthorized returns will not be accepted and will be returned freight collect.

### PARTIAL SHIPMENTS

We will make every attempt to ship orders complete and on schedule. However, we reserve the right to make partial shipments, as merchandise is ready. Invoices covering these shipments are to be paid as they become due.

### ORDER CHANGE — CANCELLATIONS

Our order confirmation is final and binding. Any order change or cancellation is subject to our ability to conform. Such requests are to be made in writing to our office.

### SHIPMENT AND PREPAID FREIGHT

Unless otherwise instructed, we reserve the option to ship by what is, in our opinion, the best possible way. Upon request, we will prepay and add freight for accounts with established credit.

### DELIVERY

We are not liable for delay or failure of delivery due to strikes and/or differences with workmen, war, riot, fire, compliance with government regulations, acts of nature, failure or delays of sources of supply, or any other causes beyond our control.

### STORAGE

If buyer cannot accept delivery when merchandise is ready, we reserve the right to transfer goods to storage. Costs of transfer and storage will be charged to the buyer's account, and we will deem such transfer as constituting shipment for all purposes, including invoicing, as of the date the transfer is made.

---

## Terms and Conditions

### CONSTRUCTION – SPECIFICATIONS

All items are produced to price list specifications unless otherwise advised. All dimensions shown are approximate. Manufacturer reserves the right to make modifications and/or improvements without prior notice.

### FABRIC APPLICATION

Standard fabric application for tiles is horizontal application. Friant & Associates is not responsible for charges associated with replacement of products due to incorrect specifications.

### CUSTOMER'S OWN MATERIAL

Yardage requirement is based on 66" wide plain covering material, and must be increased if less than 66" wide. Special instructions for handling material (pattern, directional fabric, right side of reversible fabric, etc.) must be submitted in writing before fabric is delivered. In the absence of special instructions, we reserve the right to use our own judgment. We reserve the right to reject any covering, which in our opinion, is unsuitable for our upholstery purposes. However, in no instance shall we be held responsible for unsatisfactory results due to use of covering unsuitable for our upholstery methods.

We will not be responsible for errors caused by buyers not supplying us with sample cuttings attached to their order giving full identification of covering material, (name of supplier, covering name, number and color) for identification purposes and advising us of model number and quantity to which each cover is to be applied.

Customer's own material that is shipped freight collect will be refused. A service charge will be applied for the return of unusable C.O.M. Contact factory.

### RIGHTS AND WARRANTIES – LIMITED LIFETIME WARRANTY

This warranty is given to the initial purchaser and is valid from the date of purchase, for as long as the initial purchaser owns the product. This warranty covers defects in material and craftsmanship found during normal usage of the product during the warranty period. If the product is defective, and if written notice of the defect is given to Friant & Associates within the applicable warranty period, Friant & Associates, at its option, will either repair or replace the defective product with a comparable component or product. This warranty applies to all products except as noted below.

High wear parts, such as wood veneer, fabrics, and other covering material/finishes, foam, glides, etc. are warranted for one (1) year. This warranty does not apply to damage caused by a carrier, alteration to the product not expressly authorized by Friant & Associates, nor to product considered to be of a consumable nature such as bulbs, light ballasts, etc. It also does not apply to "Customer's Own Material" (i.e. material specified by the customer that is not a standard Friant & Associates offering) used in the manufacture of Friant & Associates products.

Friant & Associates does not warrant the matching of colors, grain or texture, except to within commercially acceptable standards.

A product will not be considered defective, and Friant & Associates will not be obligated to replace it, if it is not installed in a proper manner (i.e. product not leveled, not secured properly, etc.).

Except as noted above, Friant & Associates makes no express or implied warranties to any product, and in particular makes no warranty of fitness for any particular use. At Friant & Associates' option, product repair and replacement is the customer's exclusive remedy for any and all product defects.

Friant & Associates shall not be liable for consequential, economic, or incidental damages arising from any product defect.

### CALIFORNIA PROP 65 WARNING

Products in this catalog may contain a chemical known to the state of California to cause cancer, or birth defects or other reproductive harm.

## Standard Fabrics and Finishes

### Standard Fabrics

PASSAGE		TERRAIN		SLIDE	
PF601-1	Gull	PF701-1	Cloud	PF101-1	Caramel
PF601-2	Grove	PF701-2	Dusk	PF101-2	Slate
PF601-3	Wing	PF701-3	Wave	PF101-3	Pewter
PF601-4	Quartz	PF701-4	Earth	PF101-4	Verde
PF601-5	Leaf			PF101-5	Twilight
PF601-6	Brook			PF101-6	Vintage
PF601-7	Trail			PF101-7	Java
PF601-8	Amber			PF101-8	Latte
				PF101-9	Sterling
				PF101-10	Crema
				PF101-11	Breeze
				PF101-12	Stem

**NOTE:** Fabric direction as per Friant's fabric card only.

Standard fabric application for panels 67" and below is horizontal application. Panels taller than 67" are only available in vertical application. When ordering panels 67" and below to match a panel taller than 67", specify vertical application.

All textiles listed are 66" wide.

Additional fabric cards can be ordered directly from Burch Fabrics and Guilford of Maine.

Order Interra fabric cards online at [www.friant.com/samples](http://www.friant.com/samples).

Colors may vary slightly between dye lots.

SKY		SILKY		STICKS	
PF301-1	Terra	PF401-1	Natural	PF501-1	Smoke
PF301-2	Birch	PF401-2	Parids	PF501-2	Almond
PF301-3	Moss	PF401-3	Overcast	PF501-3	Sage
		PF401-4	Field	PF501-4	Straw
		PF401-5	Graphite		

Please consult your Friant sales consultant for:

- Panels taller than 66" high
- Other colors not listed above
- C.O.M. fabric

### Standard Finishes

For other worksurface finish colors, please consult your Friant sales consultant.

WORKSURFACE FINISHES		EDGE FINISHES (3MM PVC)		PAINT TRIM	
M1	Light Maple	E1	Light Maple	LG Light Gray	
M2	Light Cherry	E2	Light Cherry	BU Black Umber	
M3	Medium Cherry	E3	Medium Cherry		
M4	Mahogany	E4	Mahogany		
M5	Light Mahogany	E5	Light Mahogany	LG Light Gray	
M6	Light Gray	E6	Light Gray	BU Black Umber	
M7	White	E7	White		
M8	Gray Specks	E13	Black Umber		

**NOTE:** Tiles is MAS Green Certified. For more information on LEED or environmental information about our products, contact the factory at [spec@friant.com](mailto:spec@friant.com) or visit our website at [www.friant.com](http://www.friant.com).

#### BASE FINISH

LG Light Gray  
BU Black Umber

#### END PANEL

LG Light Gray  
BU Black Umber

# Tile Application

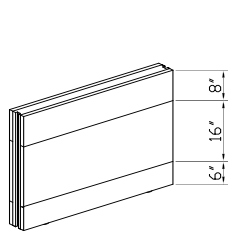

30"H FRAME

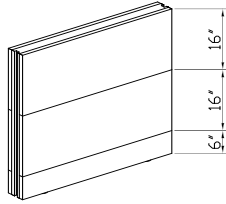

38"H FRAME

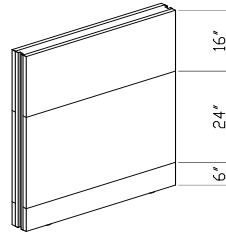

46"H FRAME

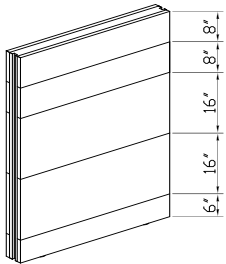

54"H FRAME

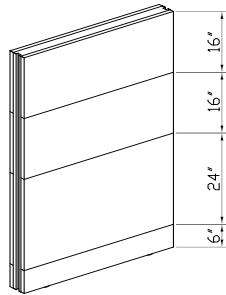

62"H FRAME

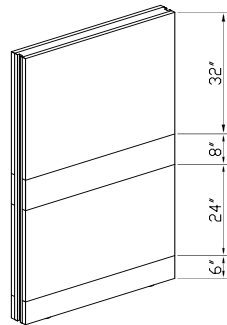

70"H FRAME

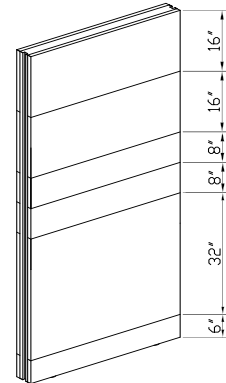

86"H FRAME

### FRAME SIZES, AND SPACE AVAILABLE FOR TILE APPLICATION

FRAME HEIGHT	SPACE AVAILABLE
30" high	24" height
38" high	32" height
46" high	40" height
54" high	48" height
62" high	56" height
70" high	64" height
86" high	80" height

### ABOUT THE FRAMES

Each frame has a 6" high base with base covers. Each frame can be filled with a combination of Tiles of different sizes, material and finishes on either side of the frame.

### APPLICATION

The application on one side of a frame does not need to match the other side of the frame, except as noted in this price list under Notes.

## Non-Powered Frames

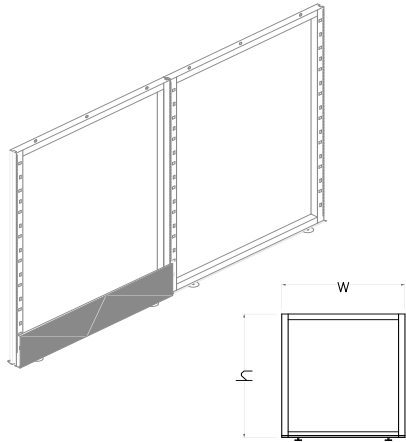

### DESCRIPTION

Each frame holds individual tiles on either side and comes with top cap, base covers, and adjustable glides.

### NOTES

- To connect 2 frames in a straight line, order 1 Draw Rod.
- When connecting 2 frames of different heights, order Finished End Change of Height separately.
- Frame finish: Black only

### SPECIFICATION OPTIONS

**product #:** see charts below  
**base and top cap finish:** LG Light Gray, BU Black Umber

### ORDER EXAMPLE

**product #:** FTF-3018-N  
**base and top cap finish:** LG

### 30" HIGH

PART #	HEIGHT	WIDTH	DEPTH	WT. (LBS)	PRICE
FTF-3018-N	30"	18"	3.5"	11	\$133
FTF-3024-N	30"	24"	3.5"	13	\$152
FTF-3030-N	30"	30"	3.5"	15	\$172
FTF-3036-N	30"	36"	3.5"	17	\$192
FTF-3042-N	30"	42"	3.5"	19	\$209
FTF-3048-N	30"	48"	3.5"	21	\$227

### 38" HIGH

PART #	HEIGHT	WIDTH	DEPTH	WT. (LBS)	PRICE
FTF-3818-N	38"	18"	3.5"	13	\$147
FTF-3824-N	38"	24"	3.5"	15	\$166
FTF-3830-N	38"	30"	3.5"	17	\$186
FTF-3836-N	38"	36"	3.5"	19	\$205
FTF-3842-N	38"	42"	3.5"	21	\$223
FTF-3848-N	38"	48"	3.5"	23	\$241

### 46" HIGH

PART #	HEIGHT	WIDTH	DEPTH	WT. (LBS)	PRICE
FTF-4618-N	46"	18"	3.5"	14	\$160
FTF-4624-N	46"	24"	3.5"	16	\$179
FTF-4630-N	46"	30"	3.5"	18	\$199
FTF-4636-N	46"	36"	3.5"	20	\$219
FTF-4642-N	46"	42"	3.5"	22	\$236
FTF-4648-N	46"	48"	3.5"	23	\$255



**54" HIGH**

PART #	HEIGHT	WIDTH	DEPTH	WT. (LBS)	PRICE
FTF-5418-N	54"	18"	3.5"	17	\$173
FTF-5424-N	54"	24"	3.5"	19	\$193
FTF-5430-N	54"	30'	3.5"	21	\$213
FTF-5436-N	54"	36"	3.5"	23	\$233
FTF-5442-N	54"	42"	3.5"	25	\$251
FTF-5448-N	54"	48"	3.5"	27	\$269

**62" HIGH**

PART #	HEIGHT	WIDTH	DEPTH	WT. (LBS)	PRICE
FTF-6218-N	62"	18"	3.5"	19	\$191
FTF-6224-N	62"	24"	3.5"	21	\$212
FTF-6230-N	62"	30'	3.5"	23	\$230
FTF-6236-N	62"	36"	3.5"	25	\$250
FTF-6242-N	62"	42"	3.5"	27	\$268
FTF-6248-N	62"	48"	3.5"	29	\$287

**70" HIGH**

PART #	HEIGHT	WIDTH	DEPTH	WT. (LBS)	PRICE
FTF-7018-N	70"	18"	3.5"	22	\$204
FTF-7024-N	70"	24"	3.5"	23	\$223
FTF-7030-N	70"	30'	3.5"	24	\$244
FTF-7036-N	70"	36"	3.5"	26	\$264
FTF-7042-N	70"	42"	3.5"	28	\$282
FTF-7048-N	70"	48"	3.5"	30	\$301

**86" HIGH**

PART #	HEIGHT	WIDTH	DEPTH	WT. (LBS)	PRICE
FTF-8618-N	86"	18"	3.5"	25	\$242
FTF-8624-N	86"	24"	3.5"	27	\$259
FTF-8630-N	86"	30'	3.5"	29	\$277
FTF-8636-N	86"	36"	3.5"	31	\$296
FTF-8642-N	86"	42"	3.5"	33	\$314
FTF-8648-N	86"	48"	3.5"	35	\$329

## Powered Frames with Duplex Cutouts

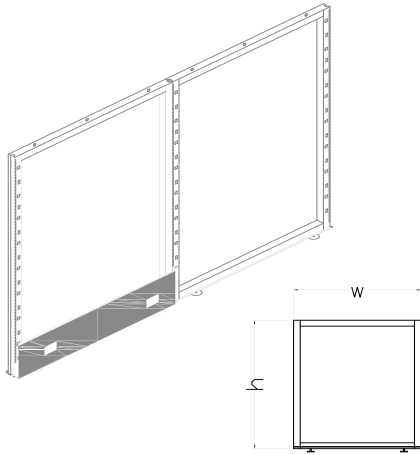

### DESCRIPTION

Each frame holds individual tiles on either side and comes with top cap, base covers, and adjustable glides. Base covers have cutouts for power.

Power Retro is used to access power at the base level. It distributes up to 4 20-amp circuits, and provides duplex locations on both sides of the frame. Power Retro and Frame-to-Frame Festoon is included. Electrical can be installed at the base or above the worksurface

### NOTES

- To connect 2 frames in a straight line, order 1 Draw Rod.
- When connecting 2 frames of different heights, order Finished End Change of Height separately.
- Power Retro is included.
- To install power above the worksurface, order Beltline Power Retro.
- 18"W power frame has no power access.
- 24"W power frames have 1 duplex location per side.
- 30", 36", 42" and 48"W power frames have 2 duplex locations per side.
- Frame finish: Black only.

### SPECIFICATION OPTIONS

**product #:** see charts below  
**base and top cap finish:** LG Light Gray, BU Black Umber

### ORDER EXAMPLE

**product #:** FTF-3018-E  
**base and top cap finish:** LG

#### 30" HIGH

PART #	HEIGHT	WIDTH	DEPTH	WT. (LBS)	PRICE
FTF-3018-E	30"	18"	3.5"	13	\$258
FTF-3024-E	30"	24"	3.5"	15	\$278
FTF-3030-E	30"	30"	3.5"	17	\$313
FTF-3036-E	30"	36"	3.5"	19	\$350
FTF-3042-E	30"	42"	3.5"	21	\$384
FTF-3048-E	30"	48"	3.5"	23	\$418

#### 38" HIGH

PART #	HEIGHT	WIDTH	DEPTH	WT. (LBS)	PRICE
FTF-3818-E	38"	18"	3.5"	15	\$272
FTF-3824-E	38"	24"	3.5"	17	\$291
FTF-3830-E	38"	30"	3.5"	19	\$327
FTF-3836-E	38"	36"	3.5"	21	\$363
FTF-3842-E	38"	42"	3.5"	23	\$397
FTF-3848-E	38"	48"	3.5"	26	\$431

**46" HIGH**

PART #	HEIGHT	WIDTH	DEPTH	WT. (LBS)	PRICE
FTF-4618-E	46"	18"	3.5"	16	\$285
FTF-4624-E	46"	24"	3.5"	18	\$305
FTF-4630-E	46"	30'	3.5"	20	\$340
FTF-4636-E	46"	36"	3.5"	22	\$377
FTF-4642-E	46"	42"	3.5"	23	\$411
FTF-4648-E	46"	48"	3.5"	26	\$446

**54" HIGH**

PART #	HEIGHT	WIDTH	DEPTH	WT. (LBS)	PRICE
FTF-5418-E	54"	18"	3.5"	19	\$298
FTF-5424-E	54"	24"	3.5"	21	\$318
FTF-5430-E	54"	30'	3.5"	23	\$354
FTF-5436-E	54"	36"	3.5"	25	\$391
FTF-5442-E	54"	42"	3.5"	27	\$425
FTF-5448-E	54"	48"	3.5"	28	\$460

**62" HIGH**

PART #	HEIGHT	WIDTH	DEPTH	WT. (LBS)	PRICE
FTF-6218-E	62"	18"	3.5"	21	\$315
FTF-6224-E	62"	24"	3.5"	23	\$338
FTF-6230-E	62"	30'	3.5"	25	\$370
FTF-6236-E	62"	36"	3.5"	27	\$408
FTF-6242-E	62"	42"	3.5"	29	\$443
FTF-6248-E	62"	48"	3.5"	31	\$477

**70" HIGH**

PART #	HEIGHT	WIDTH	DEPTH	WT. (LBS)	PRICE
FTF-7018-E	70"	18"	3.5"	23	\$315
FTF-7024-E	70"	24"	3.5"	24	\$338
FTF-7030-E	70"	30'	3.5"	26	\$370
FTF-7036-E	70"	36"	3.5"	28	\$408
FTF-7042-E	70"	42"	3.5"	30	\$443
FTF-7048-E	70"	48"	3.5"	32	\$477

**86" HIGH**

PART #	HEIGHT	WIDTH	DEPTH	WT. (LBS)	PRICE
FTF-8618-E	86"	18"	3.5"	27	\$367
FTF-8624-E	86"	24"	3.5"	29	\$385
FTF-8630-E	86"	30'	3.5"	31	\$418
FTF-8636-E	86"	36"	3.5"	33	\$454
FTF-8642-E	86"	42"	3.5"	35	\$488
FTF-8648-E	86"	48"	3.5"	37	\$520

## Powered Frames Power and Data with Duplex Cutouts

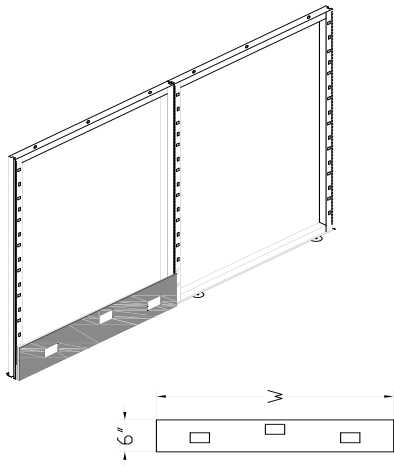

### DESCRIPTION

Each frame holds individual tiles on either side and comes with top cap, base covers, and adjustable glides. Base covers have cutouts for power and data plate.

Power Retro is used to access power at the base level. It distributes up to 4 20-amp circuits, and provides duplex locations on both sides of the frame. Power Retro and Frame-to-Frame Festoon is included. Electrical can be installed at the base or above the worksurface.

### NOTES

- To connect 2 frames in a straight line, order 1 Draw Rod.
- When connecting 2 frames of different heights, order Finished End Change of Height separately.
- Power Retro is included.
- To install power above the worksurface, order Beltline Power Retro.
- 18"W power frame has no power access.
- 24"W power frames have 1 duplex location per side.
- 30", 36", 42" and 48"W power frames have 2 duplex locations per side.
- Data Port location is on the right side of the base covers for 24" and 30"W frames, and at the center of the base covers on 36", 42" and 48"W frames.
- Order Data Port Plate separately.
- Frame finish: Black only

### SPECIFICATION OPTIONS

**product #:** see charts below  
**base and top cap finish:** LG Light Gray, BU Black Umber

### ORDER EXAMPLE

**product #:** FTF-3018-ED  
**base and top cap finish:** LG

### 30" HIGH

PART #	HEIGHT	WIDTH	DEPTH	WT. (LBS)	PRICE
FTF-3018-ED	30"	18"	3.5"	13	\$260
FTF-3024-ED	30"	24"	3.5"	15	\$281
FTF-3030-ED	30"	30"	3.5"	17	\$316
FTF-3036-ED	30"	36"	3.5"	19	\$353
FTF-3042-ED	30"	42"	3.5"	21	\$387
FTF-3048-ED	30"	48"	3.5"	23	\$421

### 38" HIGH

PART #	HEIGHT	WIDTH	DEPTH	WT. (LBS)	PRICE
FTF-3818-ED	38"	18"	3.5"	15	\$275
FTF-3824-ED	38"	24"	3.5"	17	\$294
FTF-3830-ED	38"	30"	3.5"	19	\$330
FTF-3836-ED	38"	36"	3.5"	21	\$366
FTF-3842-ED	38"	42"	3.5"	23	\$400
FTF-3848-ED	38"	48"	3.5"	26	\$434

**46" HIGH**

PART #	HEIGHT	WIDTH	DEPTH	WT. (LBS)	PRICE
FTF-4618-ED	46"	18"	3.5"	16	\$288
FTF-4624-ED	46"	24"	3.5"	18	\$308
FTF-4642-ED	46"	30"	3.5"	20	\$343
FTF-4636-ED	46"	36"	3.5"	22	\$380
FTF-4642-ED	46"	42"	3.5"	23	\$414
FTF-4648-ED	46"	48"	3.5"	26	\$449

**54" HIGH**

PART #	HEIGHT	WIDTH	DEPTH	WT. (LBS)	PRICE
FTF-5418-ED	54"	18"	3.5"	19	\$301
FTF-5424-ED	54"	24"	3.5"	21	\$321
FTF-5430-ED	54"	30"	3.5"	23	\$357
FTF-5436-ED	54"	36"	3.5"	25	\$394
FTF-5442-ED	54"	42"	3.5"	27	\$428
FTF-5448-ED	54"	48"	3.5"	28	\$463

**62" HIGH**

PART #	HEIGHT	WIDTH	DEPTH	WT. (LBS)	PRICE
FTF-6218-ED	62"	18"	3.5"	21	\$318
FTF-6224-ED	62"	24"	3.5"	23	\$341
FTF-6230-ED	62"	30"	3.5"	25	\$373
FTF-6236-ED	62"	36"	3.5"	27	\$411
FTF-6242-ED	62"	42"	3.5"	29	\$446
FTF-6248-ED	62"	48"	3.5"	31	\$480

**70" HIGH**

PART #	HEIGHT	WIDTH	DEPTH	WT. (LBS)	PRICE
FTF-7018-ED	70"	18"	3.5"	23	\$318
FTF-7024-ED	70"	24"	3.5"	24	\$341
FTF-7030-ED	70"	30"	3.5"	26	\$373
FTF-7036-ED	70"	36"	3.5"	28	\$411
FTF-7042-ED	70"	42"	3.5"	30	\$446
FTF-7048-ED	70"	48"	3.5"	32	\$480

**86" HIGH**

PART #	HEIGHT	WIDTH	DEPTH	WT. (LBS)	PRICE
FTF-8618-ED	86"	18"	3.5"	27	\$370
FTF-8624-ED	86"	24"	3.5"	29	\$388
FTF-8630-ED	86"	30"	3.5"	31	\$421
FTF-8636-ED	86"	36"	3.5"	33	\$457
FTF-8642-ED	86"	42"	3.5"	35	\$491
FTF-8648-ED	86"	48"	3.5"	37	\$523

## Stacking Frames & Draw Nut

DESCRIPTION

SPECIFICATION OPTIONS

NOTES

product #: see charts below

ORDER EXAMPLE

product #: FTSF.1618

### STACKING FRAMES

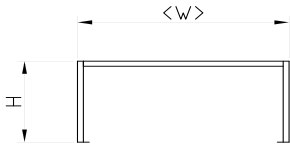
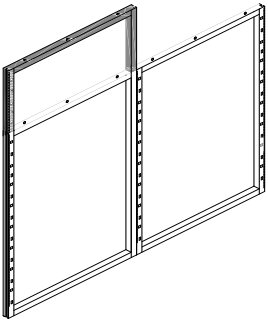

PART #	HEIGHT	WIDTH	DEPTH	WT. (LBS)	PRICE
FTSF.1618	16"	18"	2"	6	\$75
FTSF.1624	16"	24"	2"	8	\$83
FTSF.1630	16"	30"	2"	8	\$89
FTSF.1636	16"	36"	2"	9	\$94
FTSF.1642	16"	42"	2"	10	\$99
FTSF.1648	16"	48"	2"	11	\$105

DESCRIPTION & NOTES

DESCRIPTION:  
Stacking Frame attaches to the top of a base frame, and holds individual tiles on both sides. This frame also attaches to an adjacent frame, or connector of same height.

Attachment hardware is included.

NOTES:

- If using Window Tiles, order Window Tile Top only.
- Standard components can hang from the stacking frame.
- No more than 2 Stacking Frames can be added to a base frame for a maximum height of 118".
- Order Stacking Connectors separately when needed.
- Order Finished End or Finished End Change of Height separately.
- Stacking Frame includes 1 Draw Nut. Order additional Draw Nuts if needed.
- Draw Nuts connect Stacking Frames in a straight line, or connect Stacking Frames to a 2, 3-, 4-Way connector and Spacer Connector.
- Top Cap can be removed from existing frame, and reused on Stacking Frame.
- When using Stacking Frame next to a higher frame or connector, order change of height trim.

### DRAW NUT

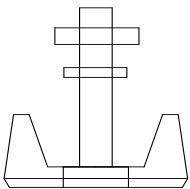

PART #	HEIGHT	WIDTH	DEPTH	WT. (LBS)	PRICE
FTDRN	—	—	—	1	\$6

DESCRIPTION & NOTES

DESCRIPTION:  
This Draw Nut is used to connect 2 Stacking Frames side by side, or to connect a Stacking Frame to a Connector.

NOTES:

- Order 1 Draw Nut for each Stacking Frame to Stacking Frame or Stacking Frame to Connector connection. Each Stacking Frame includes 1 Draw Nut.

# Door Frames

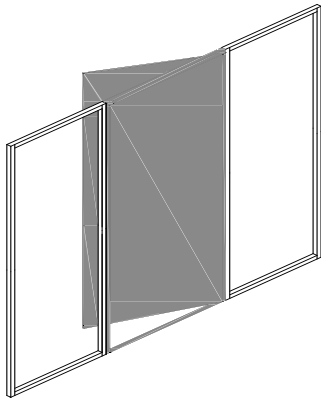

DESCRIPTION

This Door Frame connects to an adjacent 86"H Frame. Comes with an 83-1/2"H Door, a standard top cap, door knob, door stop, carpet grippers and hinges.

Door Frame cannot be powered. Hinges and door knob have a satin aluminum finish standard.

NOTES

- Specify L for left hand swing, and R for right hand swing.
- Order Draw Rod separately.
- Frame finish: Black only

SPECIFICATION OPTIONS

**product #:** see charts below  
**finish:** LG Light Gray, BU Black Umber

ORDER EXAMPLE

**product #:** FTDOPA.8636L  
**finish:** LG

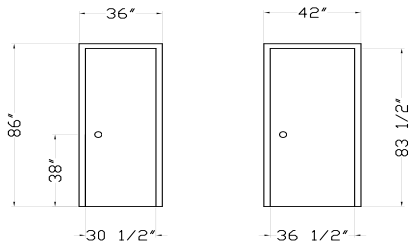

PART #	HEIGHT	WIDTH	DEPTH	WT. (LBS)	PRICE
FTDOPA.8636L	86"	36"	38	\$2,560	
FTDOPA.8636R	86"	36"	38	\$2,560	
FTDOPA.8642L	86"	42"	45	\$2,740	
FTDOPA.8642R	86"	42"	45	\$2,740	

## Draw Rod

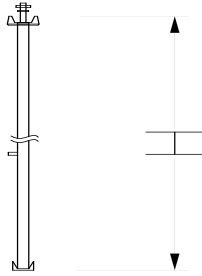
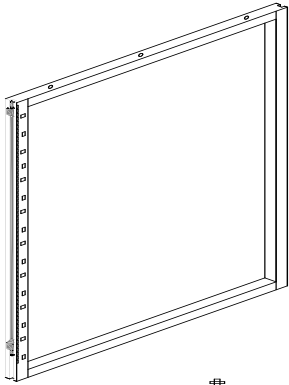

### DESCRIPTION

Draw Rods connect frames in a straight line, or connect frames to a 2-, 3-, 4-Way connector and Spacer Connector.

### NOTES

- When connecting frames of different heights to each other, or to a connector, order Draw Rods to match the height of each frame.
- If frames are not the same height, order Finished End Change of Height for each connecting point separately.
- Finish: Black only.

### SPECIFICATION OPTIONS

**product #:** see charts below

### ORDER EXAMPLE

**product #:** FTDR.1130

PART #	HEIGHT	WIDTH	DEPTH	WT. (LBS)	PRICE
FTDR.1130	30"	—	—	2	\$18
FTDR.1138	38"	—	—	2	\$21
FTDR.1146	46"	—	—	2	\$24
FTDR.1154	54"	—	—	3	\$27
FTDR.1162	62"	—	—	3	\$29
FTDR.1170	70"	—	—	3	\$32
FTDR.1186	86"	—	—	3	\$38



# Connectors

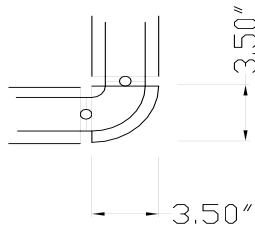
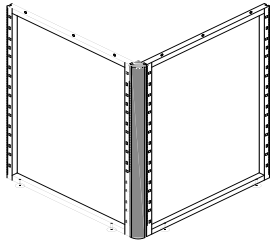

DESCRIPTION

SPECIFICATION OPTIONS

NOTES

- Order Draw Rods to match the height of each frame.
- If frames are not of the same height, order Connector to match the height of the taller frame.
- If frames are not of the same height as the connector, order Finished End Change of Height separately.

**product #:** see charts below  
**side cover and top cap finish:** LG Light Gray, BU Black Umber

ORDER EXAMPLE

**product #:** FTC2W90.30  
**side cover and top cap finish:** LG Light Gray

## 2-WAY 90° CONNECTOR

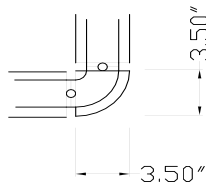
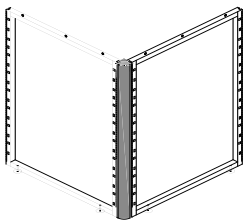

PART #	HEIGHT	WIDTH	DEPTH	WT. (LBS)	PRICE
FTC2W90.30	30"	3.5"	3.5"	9	\$96
FTC2W90.38	38"	3.5"	3.5"	11	\$111
FTC2W90.46	46"	3.5"	3.5"	12	\$129
FTC2W90.54	54"	3.5"	3.5"	14	\$149
FTC2W90.62	62"	3.5"	3.5"	16	\$167
FTC2W90.70	70"	3.5"	3.5"	18	\$183
FTC2W90.86	86"	3.5"	3.5"	20	\$224

DESCRIPTION & NOTES

**DESCRIPTION:**  
 This connector joins 2 frames of the same or different heights at a 90° angle.

Includes a Top Cap and a Radius Connector Cover.

## 2-WAY 120° CONNECTOR

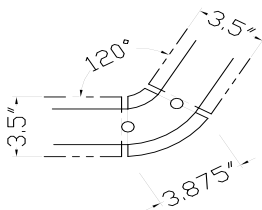
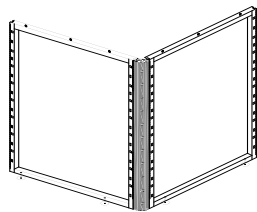

PART #	HEIGHT	WIDTH	DEPTH	WT. (LBS)	PRICE
FTC2W120.30	30"	3.875"	3.5"	9	\$160
FTC2W120.38	38"	3.875"	3.5"	11	\$183
FTC2W120.46	46"	3.875"	3.5"	12	\$206
FTC2W120.54	54"	3.875"	3.5"	14	\$231
FTC2W120.62	62"	3.875"	3.5"	16	\$255
FTC2W120.70	70"	3.875"	3.5"	18	\$277
FTC2W120.86	86"	3.875"	3.5"	20	\$324

DESCRIPTION & NOTES

**DESCRIPTION:**  
 This connector joins 2 frames of the same or different heights at a 120° angle.

Includes a Top Cap and a Radius Connector Cover.

Connectors continued

2-WAY 135° CONNECTOR

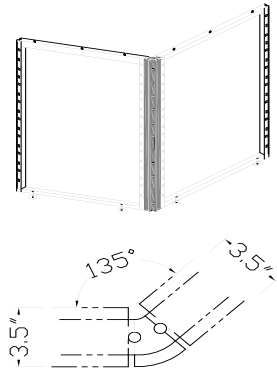

PART #	HEIGHT	WIDTH	DEPTH	WT. (LBS)	PRICE
FTC2W135.30	30"		3.5"	9	\$154
FTC2W135.38	38"		3.5"	11	\$176
FTC2W135.46	46"		3.5"	12	\$198
FTC2W135.54	54"		3.5"	14	\$222
FTC2W135.62	62"		3.5"	16	\$244
FTC2W135.70	70"		3.5"	18	\$264
FTC2W135.86	86"		3.5"	20	\$309

DESCRIPTION & NOTES

DESCRIPTION:  
This connector joins 2 frames of the same or different heights at a 135° angle.

It includes a Top Cap and a Radius Connector Cover.

3-WAY 90° CONNECTOR

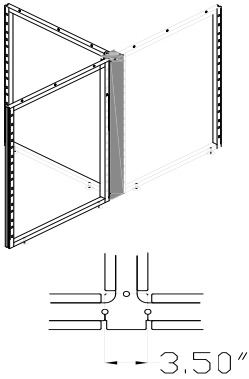

PART #	HEIGHT	WIDTH	DEPTH	WT. (LBS)	PRICE
FTC3W90.30	30"	3.5"	3.5"	10	\$100
FTC3W90.38	38"	3.5"	3.5"	12	\$119
FTC3W90.46	46"	3.5"	3.5"	14	\$138
FTC3W90.54	54"	3.5"	3.5"	16	\$159
FTC3W90.62	62"	3.5"	3.5"	19	\$178
FTC3W90.70	70"	3.5"	3.5"	21	\$195
FTC3W90.86	86"	3.5"	3.5"	23	\$235

DESCRIPTION & NOTES

DESCRIPTION:  
This connector joins 3 frames of the same or different heights at a 90° angle.

It includes a Top Cap and a Radius Connector Cover.

3-WAY 120° CONNECTOR

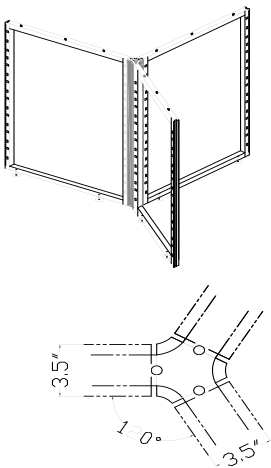

PART #	HEIGHT	WIDTH	DEPTH	WT. (LBS)	PRICE
FTC3W120.30	30"	4.5"	3.5"	10	\$109
FTC3W120.38	38"	4.5"	3.5"	12	\$126
FTC3W120.46	46"	4.5"	3.5"	14	\$142
FTC3W120.54	54"	4.5"	3.5"	16	\$159
FTC3W120.62	62"	4.5"	3.5"	19	\$175
FTC3W120.70	70"	4.5"	3.5"	21	\$190
FTC3W120.86	86"	4.5"	3.5"	23	\$221

DESCRIPTION & NOTES

DESCRIPTION:  
This connector joins 3 frames of the same or different heights at a 120° angle.

It includes a Top Cap and a Radius Connector Cover.

**4-WAY 90° CONNECTOR**

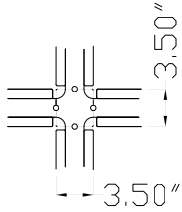
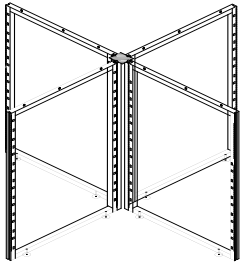

PART #	HEIGHT	WIDTH	DEPTH	WT. (LBS)	PRICE
FTC4W90.30	30"	3.5"	3.5"	11	\$82
FTC4W90.38	38"	3.5"	3.5"	14	\$97
FTC4W90.46	46"	3.5"	3.5"	16	\$112
FTC4W90.54	54"	3.5"	3.5"	19	\$127
FTC4W90.62	62"	3.5"	3.5"	21	\$143
FTC4W90.70	70"	3.5"	3.5"	24	\$156
FTC4W90.86	86"	3.5"	3.5"	26	\$187

**DESCRIPTION & NOTES**

**DESCRIPTION:**  
This connector joins 4 frames of the same or different heights at a 90° angle.

Includes a Top Cap and a Radius Connector Cover.

**SPACER CONNECTOR**

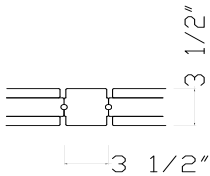
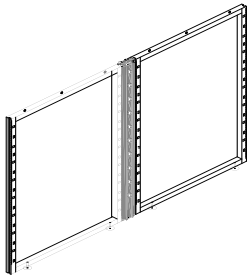

PART #	HEIGHT	WIDTH	DEPTH	WT. (LBS)	PRICE
FTSC.30	30"	3.5"	3.5"	14	\$164
FTSC.38	38"	3.5"	3.5"	16	\$195
FTSC.46	46"	3.5"	3.5"	19	\$226
FTSC.54	54"	3.5"	3.5"	21	\$260
FTSC.62	62"	3.5"	3.5"	26	\$291
FTSC.70	70"	3.5"	3.5"	30	\$320
FTSC.86	86"	3.5"	3.5"	35	\$385

**DESCRIPTION & NOTES**

**DESCRIPTION:**  
This Spacer joins 2 frames of the same or different heights in a straight line, and compensates for dimensional gains in a wall run. Includes a Top Cap, and 2 side covers.

**NOTES:**

- Power cannot run through a spacer at beltline level — only at the base.

## Stacking Connectors

### DESCRIPTION

### SPECIFICATION OPTIONS

**product #:** see charts below  
**side cover and top cap finish:** LG Light Gray, BU Black Umber

### NOTES

- If adjacent frame is not the same height as the combined height of existing Connector and Stacking Connector, order Change of Height Finished End separately.
- Top Cap can be removed from existing connector and reused on Stacking Connector.

### ORDER EXAMPLE

**product #:** FTSC2W90.16  
**side cover and top cap finish:** LG Light Gray

### 2-WAY 90° STACKING CONNECTOR

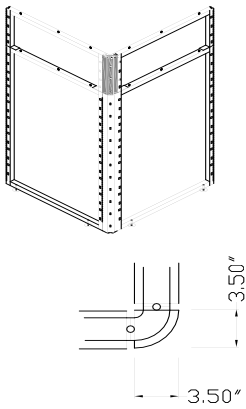

PART #	HEIGHT	WIDTH	DEPTH	WT. (LBS)	PRICE
FTSC2W90.16	16"	3.5"	3.5"	8	\$40

### DESCRIPTION & NOTES

**DESCRIPTION:**  
 This connector extends the height of a 2-Way 90° Connector by 16" and can be attached to an adjacent frame.

Attachment hardware is included.

### NOTES:

- Only 2 Stacking Connectors can be attached to 1 Base Connector, to a maximum height of 118".
- Order Connector Cover separately, to match the combined height of the existing Connector and the Stacking Connector.

### 2-WAY 120° STACKING CONNECTOR

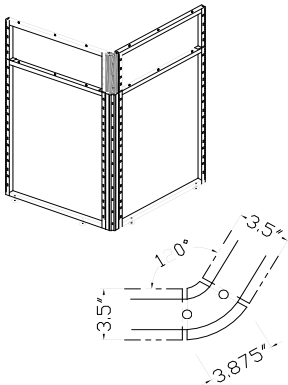

PART #	HEIGHT	WIDTH	DEPTH	WT. (LBS)	PRICE
FTSC2W120.16	16"	3.5"	3.5"	8	\$71

### DESCRIPTION & NOTES

**DESCRIPTION:**  
 This connector extends the height of a 2-Way 120° Connector by 16".

Attachment hardware is included.

### NOTES:

- Only 2 Stacking Connectors can be attached to 1 Base Connector, to a maximum height of 118".
- Order Connector Cover separately, to match the combined height of the existing Connector and the Stacking Connector.

**2-WAY 135° STACKING CONNECTOR**

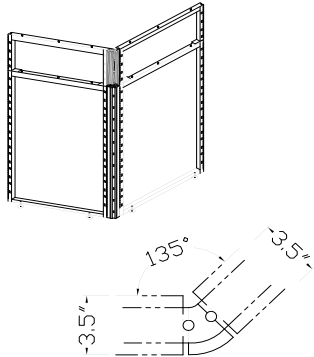

PART #	HEIGHT	WIDTH	DEPTH	WT. (LBS)	PRICE
FTSC2W135.16	16"	3.5"	3.5"	8	\$71

**DESCRIPTION & NOTES**

**DESCRIPTION:**  
This connector extends the height of a 2-Way 135° Connector by 16".

Attachment hardware is included.

- NOTES:**
- Only 2 Stacking Connectors can be attached to 1 Base Connector, to a maximum height of 118".
  - Order Connector Cover separately, to match the combined height of the existing Connector and the Stacking Connector.

**SPACER STACKING CONNECTOR**

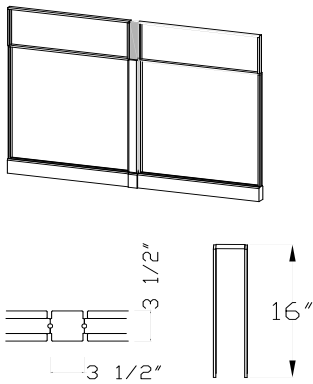

PART #	HEIGHT	WIDTH	DEPTH	WT. (LBS)	PRICE
FTSSC.16	16"	3.5"	3.5"	7	\$79

**DESCRIPTION & NOTES**

**DESCRIPTION:**  
This connector extends the height of a Spacer by 16".

Attachment hardware is included.

- NOTES:**
- Only 2 Stacking Connectors can be attached to 1 Base Connector, to a maximum height of 118".
  - Order Connector Cover separately, to match the combined height of the existing Connector and the Stacking Connector.

**3-WAY 90° STACKING CONNECTOR**

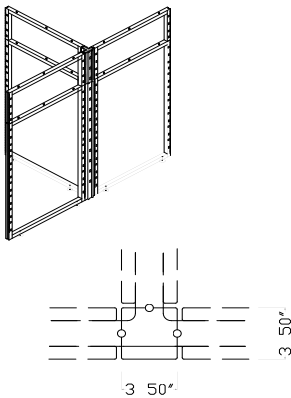

PART #	HEIGHT	WIDTH	DEPTH	WT. (LBS)	PRICE
FTSC3W90.16	16"	3.5"	3.5"	7	\$42

**DESCRIPTION & NOTES**

**DESCRIPTION:**  
This connector extends the height of a 3-Way 90° Connector by 16".

Attachment hardware is included.

- NOTES:**
- Only 2 Stacking Connectors can be attached to 1 Base Connector, to a maximum height of 118".
  - Order Connector Cover separately, to match the combined height of the existing Connector and the Stacking Connector.

## Stacking Connectors continued

### 3-WAY 120° STACKING CONNECTOR

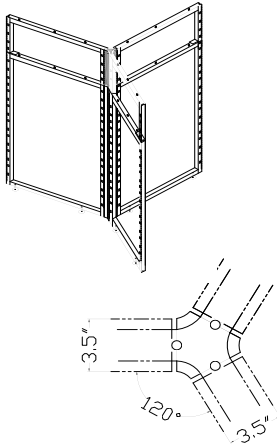

PART #	HEIGHT	WIDTH	DEPTH	WT. (LBS)	PRICE
FTSC3W120.16	16"	3.5"	3.5"	7	\$75

#### DESCRIPTION & NOTES

**DESCRIPTION:**  
This connector extends the height of a 3-Way 120° Connector by 16".

Attachment hardware is included.

**NOTES:**

- Only 2 Stacking Connectors can be attached to 1 Base Connector, to a maximum height of 118".

### 4-WAY 90° STACKING CONNECTOR

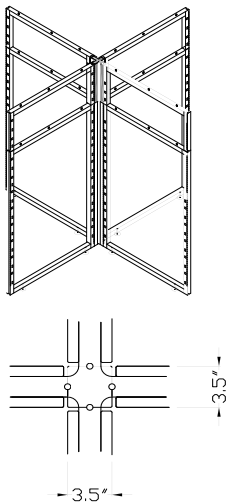

PART #	HEIGHT	WIDTH	DEPTH	WT. (LBS)	PRICE
FTSC4W90.16	16"	3.5"	3.5"	9	\$79

#### DESCRIPTION & NOTES

**DESCRIPTION:**  
This connector extends the height of a 4-Way 90° Connector by 16".

Attachment hardware is included.

**NOTES:**

- Only 2 Stacking Connectors can be attached to 1 Base Connector, to a maximum height of 118".

## Other Connectors

DESCRIPTION	SPECIFICATION OPTIONS
	<b>product #:</b> see charts below <b>side cover and top cap finish:</b> LG Light Gray, BU Black Umber
NOTES	ORDER EXAMPLE
	<b>product #:</b> FTC2W90.30 <b>side cover and top cap finish:</b> LG Light Gray

### WALL STRIP

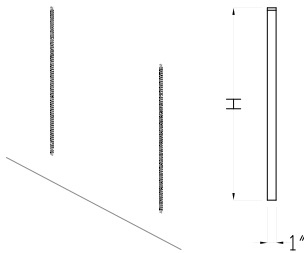

PART #	HEIGHT	WIDTH	DEPTH	WT. (LBS)	PRICE
FTWSST.40	40"	1"	.750"	4	\$29
FTWSST.56	56"	1"	.750"	5	\$38
FTWSST.64	64"	1"	.750"	6	\$44
FTWSST.80	80"	1"	.750"	8	\$54

**DESCRIPTION & NOTES**

**DESCRIPTION:**  
This double slotted strip attaches to a wall, and supports hanging components.

**NOTES:**

- Cannot be used to hold window tiles, cable access, or power and data access tiles.
- Order Tile Adapter separately to attach a tile to the Wall Strip.
- 2 Wall Strips are needed to attach a tile or a component.
- To attach a tile to the Wall Strip, order tile adapter separately.
- Specify finish: LG Light Gray or BU Black Umber

### TILE ADAPTER

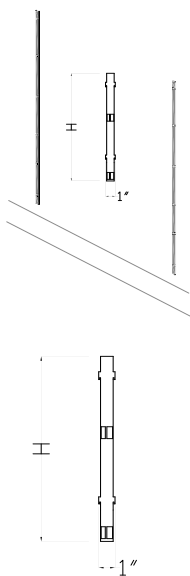

PART #	HEIGHT	WIDTH	DEPTH	WT. (LBS)	PRICE
FTTA.08	8"	1"		1	\$12
FTTA.16	16"	1"		1	\$25
FTTA.32	32"	1"		2	\$31

**DESCRIPTION & NOTES**

**DESCRIPTION:**  
Tile Adapters are used to hang Tiles from a Wall Strip.

**NOTES:**

- Cannot be used for a window tile, cable access or power and data access tiles.
- When using a combination of Tile Adapter to achieve the correct height needed, 8"H Adapter must be used at the bottom. 8"H is for use only at the bottom of a 40" or 56" Wall Strip. Not for use in any other position, nor in the 64" or 80" high Wall Strips.
- When using a 32"H Tile Adapter, do not use an 8"H tile in the bottom position.
- Tile Adapter dimension does not need to match the tile installed. (example: 24" tile should be installed on a 32" Tile Adapter.)
- Order Wall Strip separately.
- Specify LG Light Gray or BU Black.
- Sold in pairs.

## Other Connectors continued

## FINISHED END

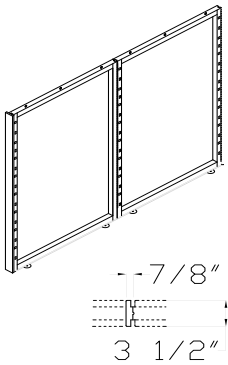

PART #	HEIGHT	WIDTH	DEPTH	WT. (LBS)	PRICE
FTFE.30	30"	3.50"	.875"	3	\$36
FTFE.38	38"	3.50"	.875"	4	\$44
FTFE.46	46"	3.50"	.875"	5	\$52
FTFE.54	54"	3.50"	.875"	6	\$60
FTFE.62	62"	3.50"	.875"	7	\$68
FTFE.70	70"	3.50"	.875"	8	\$76
FTFE.86	86"	3.50"	.875"	9	\$91

## DESCRIPTION &amp; NOTES

**DESCRIPTION:**  
This Finished End covers the exposed end of a frame.

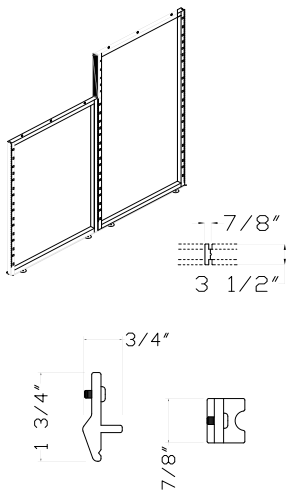
FINISHED END  
CHANGE OF HEIGHT

PART #	HEIGHT	WIDTH	DEPTH	WT. (LBS)	PRICE
FTFECH.08	8"	3.50"	.875"	1	\$14
FTFECH.12	12"	3.50"	.875"	1	\$18
FTFECH.16	16"	3.50"	.875"	2	\$23
FTFECH.24	24"	3.50"	.875"	3	\$32
FTFECH.28	28"	3.50"	.875"	3	\$37
FTFECH.32	32"	3.50"	.875"	3	\$42

## DESCRIPTION &amp; NOTES

**DESCRIPTION:**  
This Finished End Change of Height covers the exposed end of a frame or connector, when joining frames of unequal heights.

Cover includes hardware to connect frames or connectors of different heights.

## NOTES:

- When connecting 2 frames of different heights, order draw rod to match the height of the lowest frame

## WALL START

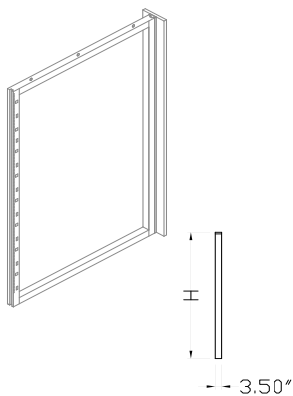

PART #	HEIGHT	WIDTH	DEPTH	WT. (LBS)	PRICE
FTWST.30	30"	3.50"	.750"	4	\$62
FTWST.38	38"	3.50"	.750"	5	\$79
FTWST.46	46"	3.50"	.750"	5	\$96
FTWST.54	54"	3.50"	.750"	6	\$114
FTWST.62	62"	3.50"	.750"	6	\$129
FTWST.70	70"	3.50"	.750"	8	\$146
FTWST.86	86"	3.50"	.750"	10	\$179

## DESCRIPTION &amp; NOTES

**DESCRIPTION:**  
This Wall Start connects a frame or a connector of the same height, to a wall or column at a 90° angle.

Includes a Draw Rod.

## NOTES:

- Specify height of the Wall Start to match the height of the frame or connector.



**CHANGE OF HEIGHT WEDGE**

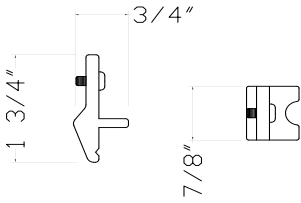

PART #	HEIGHT	WIDTH	DEPTH	WT. (LBS)	PRICE
FTCHW.30	30"	3.50"	.875"	3	\$36

**DESCRIPTION & NOTES**

**DESCRIPTION:**  
 This Wedge is used to connect a Combination Frame and a Stacking Frame to an adjacent frame or connector of greater height.

- NOTES:**
- Order 1 Change of Height Wedge for each connection point, either to a frame or connector.
  - When ordering Change of Height Wedge, order Draw Rod to match the height of the lowest frame.
  - Finish: Black

# Connector Covers

DESCRIPTION

SPECIFICATION OPTIONS

NOTES

- 78", 94" and 118"H Connector Covers are not available as a standard product.

**product #:** see charts below  
**side cover and top cap finish:** LG Light Gray, BU Black Umber

ORDER EXAMPLE

**product #:** FTCC2W90.30  
**side cover and top cap finish:** LG Light Gray

## 2-WAY 90° CONNECTOR COVER

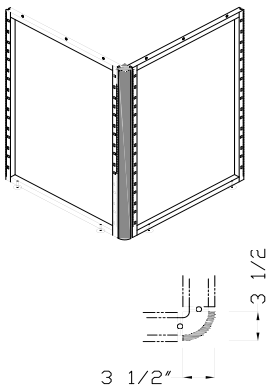

PART #	HEIGHT	WIDTH	DEPTH	WT. (LBS)	PRICE
FTCC2W90.30	30"	3.5"	.75"	2	\$42
FTCC2W90.38	38"	3.5"	.75"	2	\$51
FTCC2W90.46	46"	3.5"	.75"	3	\$59
FTCC2W90.54	54"	3.5"	.75"	3	\$69
FTCC2W90.62	62"	3.5"	.75"	4	\$78
FTCC2W90.70	70"	3.5"	.75"	4	\$87
FTCC2W90.86	86"	3.5"	.75"	5	\$106
FTCC2W90.102	102"	3.5"	.75"	6	\$138

DESCRIPTION & NOTES

**DESCRIPTION:**  
 This cover attaches to a 2-Way 90° Connector of the same height, or a 2-Way 90° Connector and 1 or 2 Stacking Connectors.

Attachment hardware is included.

## 2-WAY 120° CONNECTOR COVER

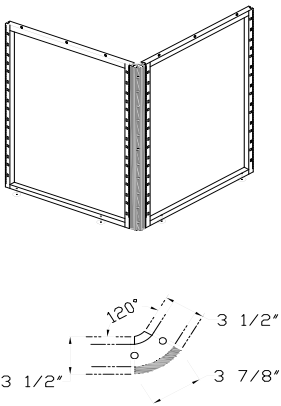

PART #	HEIGHT	WIDTH	DEPTH	WT. (LBS)	PRICE
FTCC2W120.30	30"	3.875"	.75"	2	\$67
FTCC2W120.38	38"	3.875"	.75"	2	\$76
FTCC2W120.46	46"	3.875"	.75"	3	\$84
FTCC2W120.54	54"	3.875"	.75"	3	\$95
FTCC2W120.62	62"	3.875"	.75"	4	\$104
FTCC2W120.70	70"	3.875"	.75"	4	\$113
FTCC2W120.86	86"	3.875"	.75"	5	\$133
FTCC2W120.102	102"	3.875"	.75"	6	\$148

DESCRIPTION & NOTES

**DESCRIPTION:**  
 This cover attaches to a 2-Way 120° Connector of the same height, or a 2-Way 120° Connector and 1 or 2 Stacking Connectors.

Attachment hardware is included.

**2-WAY 135° CONNECTOR COVER**

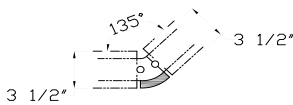
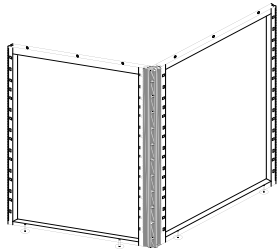

PART #	HEIGHT	WIDTH	DEPTH	WT. (LBS)	PRICE
FTCC2W135.30	30"		.75"	2	\$62
FTCC2W135.38	38"		.75"	2	\$69
FTCC2W135.46	46"		.75"	3	\$77
FTCC2W135.54	54"		.75"	3	\$86
FTCC2W135.62	62"		.75"	4	\$94
FTCC2W135.70	70"		.75"	4	\$101
FTCC2W135.86	86"		.75"	5	\$119
FTCC2W135.102	102"		.75"	6	\$134

**DESCRIPTION & NOTES**

**DESCRIPTION:**  
This cover attaches to a 2-Way 135° Connector of the same height, or a 2-Way 135° Connector and 1 or 2 Stacking Connectors.

Attachment hardware is included.

**3-WAY 90° CONNECTOR COVER**

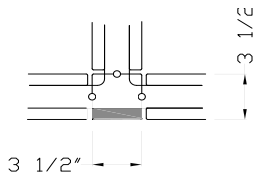
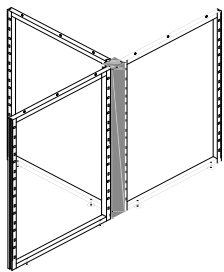

PART #	HEIGHT	WIDTH	DEPTH	WT. (LBS)	PRICE
FTCC3W90.30	30"	3.5"	.75"	1	\$32
FTCC3W90.38	38"	3.5"	.75"	2	\$38
FTCC3W90.46	46"	3.5"	.75"	2	\$44
FTCC3W90.54	54"	3.5"	.75"	2	\$52
FTCC3W90.62	62"	3.5"	.75"	3	\$58
FTCC3W90.70	70"	3.5"	.75"	3	\$64
FTCC3W90.86	86"	3.5"	.75"	4	\$78
FTCC3W90.102	102"	3.5"	.75"	5	\$98

**DESCRIPTION & NOTES**

**DESCRIPTION:**  
This cover attaches to a 3-Way 90° Connector of the same height, or a 3-Way 90° Connector and 1 or 2 Stacking Connectors.

Attachment hardware is included.

**SPACER CONNECTOR COVER**

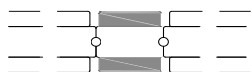
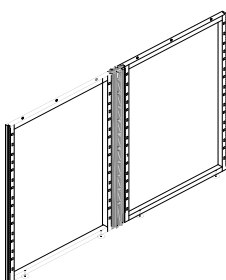

PART #	HEIGHT	WIDTH	DEPTH	WT. (LBS)	PRICE
FTCC3W90.30	30"	3.5"	.75"	1	\$32
FTCC3W90.38	38"	3.5"	.75"	2	\$38
FTCC3W90.46	46"	3.5"	.75"	2	\$44
FTCC3W90.54	54"	3.5"	.75"	2	\$52
FTCC3W90.62	62"	3.5"	.75"	3	\$58
FTCC3W90.70	70"	3.5"	.75"	3	\$64
FTCC3W90.86	86"	3.5"	.75"	4	\$78
FTCC3W90.102	102"	3.5"	.75"	5	\$98

**DESCRIPTION & NOTES**

**DESCRIPTION:**  
This Spacer Connector Cover attaches to a Spacer Connector of the same height, or to a Spacer Connector and 1 or 2 Stacking Connectors.

Attachment hardware is included.

**NOTES:**

- Order 1 Connector Cover for each side.

## Connector Covers continued

### 2-WAY 90° STACKING CONNECTOR COVER, 16"H

PART #	HEIGHT	WIDTH	DEPTH	WT. (LBS)	PRICE
FTSCC2W90.16	16"	3.5"	.75"	1	\$29

#### DESCRIPTION & NOTES

**DESCRIPTION:**  
This 2-Way 90° Connector Cover attaches to a 2-Way 90° Stacking Connector, when a full height Connector Cover is unavailable.

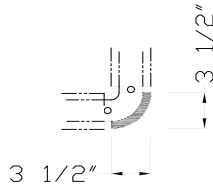
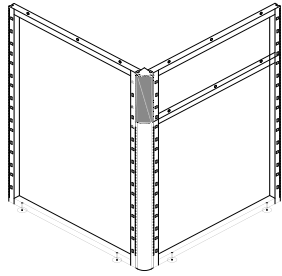

### 2-WAY 120° STACKING CONNECTOR COVER, 16"H

PART #	HEIGHT	WIDTH	DEPTH	WT. (LBS)	PRICE
FTSCC2W120.16	16"	3.5"	.75"	1	\$41

#### DESCRIPTION & NOTES

**DESCRIPTION:**  
This 2-Way 120° Connector Cover attaches to a 2-Way 120° Stacking Connector, when a full height Connector Cover is unavailable.

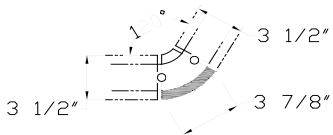
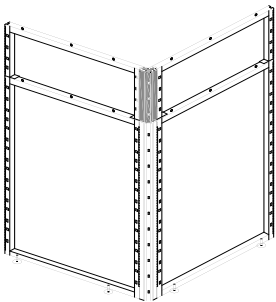

**2-WAY 135° STACKING  
CONNECTOR COVER, 16"H**

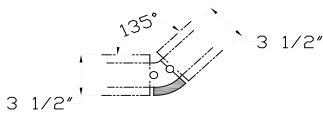
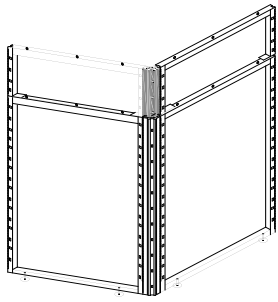

PART #	HEIGHT	WIDTH	DEPTH	WT. (LBS)	PRICE
FTSCC2W135.16	16"	3.5"	.75"	1	\$39

**DESCRIPTION & NOTES**

DESCRIPTION:  
This 2-Way 135° Connector Cover attaches to a 2-Way 135° Stacking Connector, when a full height Connector Cover is unavailable.

**3-WAY 90° STACKING  
CONNECTOR COVER, 16"H**

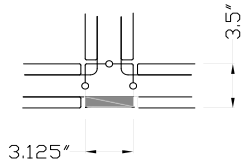
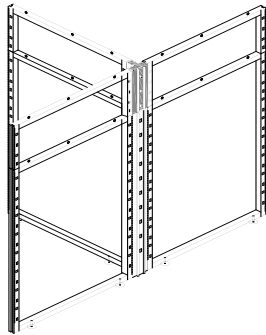

PART #	HEIGHT	WIDTH	DEPTH	WT. (LBS)	PRICE
FTSCC2W120.16	16"	3.5"	.75"	1	\$41

**DESCRIPTION & NOTES**

DESCRIPTION:  
This 3-Way 90° Connector Cover attaches to a 3-Way 90° Stacking Connector or a Spacer Stacking Connector, when a full height Connector Cover is unavailable.

## Fabric Covered Tiles

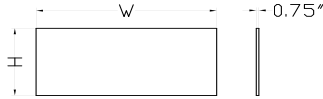
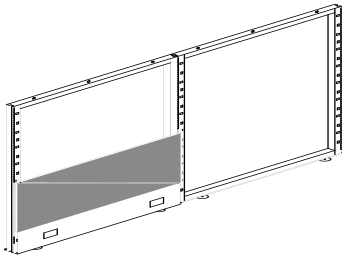

### DESCRIPTION

This Fabric Covered Tile attaches to one side of a frame or wall strips. Only 8"H fabric tiles are magnetic. 16", 24", 32", 40" and 48"H fabric tiles are tackable.

### NOTES

- To attach a Fabric Tile to a Wall Strip, order Tile Adapter separately.

### SPECIFICATION OPTIONS

**product #:** see charts below  
**fabric color:** see fabrics, page 4  
**tile finish, if applicable:** LG Light Gray, BU Black Umber

### ORDER EXAMPLE

**product #:** FTFT-0818  
**fabric color:** PF601-1, Passage-Gull  
**tile finish, if applicable:** LG Light Gray

### 8" HIGH, MAGNETIC/NON-TACKABLE

PART #	HEIGHT	WIDTH	DEPTH	WT. (LBS)	PRICE
FTFT.0818	8"	18"	.750"	2	\$46
FTFT.0824	8"	24"	.750"	3	\$49
FTFT.0830	8"	30"	.750"	3	\$57
FTFT.0836	8"	36"	.750"	4	\$63
FTFT.0842	8"	42"	.750"	4	\$70
FTFT.0848	8"	48"	.750"	5	\$77

### DESCRIPTION & NOTES

- NOTES:
- Magnetic/non-tackable surface.

### 16" HIGH, TACKABLE/ACOUSTICAL

PART #	HEIGHT	WIDTH	DEPTH	WT. (LBS)	PRICE
FTFT.1618	16"	18"	.750"	4	\$57
FTFT.1624	16"	24"	.750"	4	\$68
FTFT.1630	16"	30"	.750"	5	\$78
FTFT.1636	16"	36"	.750"	6	\$91
FTFT.1642	16"	42"	.750"	6	\$99
FTFT.1648	16"	48"	.750"	7	\$105

### DESCRIPTION & NOTES

- NOTES:
- Tackable/acoustical surface.

### 24" HIGH, TACKABLE/ACOUSTICAL

PART #	HEIGHT	WIDTH	DEPTH	WT. (LBS)	PRICE
FTFT.2418	24"	18"	.750"	5	\$76
FTFT.2424	24"	24"	.750"	6	\$88
FTFT.2430	24"	30"	.750"	6	\$95
FTFT.2436	24"	36"	.750"	8	\$120
FTFT.2442	24"	42"	.750"	9	\$130
FTFT.2448	24"	48"	.750"	9	\$142

### DESCRIPTION & NOTES

- NOTES:
- Tackable/acoustical surface.

**32" HIGH, TACKABLE/ACOUSTICAL**

PART #	HEIGHT	WIDTH	DEPTH	WT. (LBS)	PRICE
FTFT.3224	32"	24"	.750"	7	\$111
FTFT.3230	32"	30"	.750"	9	\$128
FTFT.3236	32"	36"	.750"	10	\$153
FTFT.3242	32"	42"	.750"	12	\$170
FTFT.3248	32"	48"	.750"	14	\$185

## DESCRIPTION &amp; NOTES

## NOTES:

- Tackable/acoustical surface.

**40" HIGH, TACKABLE/ACOUSTICAL**

PART #	HEIGHT	WIDTH	DEPTH	WT. (LBS)	PRICE
FTFT.4024	40"	24"	.750"	9	\$135
FTFT.4030	40"	30"	.750"	10	\$154
FTFT.4036	40"	36"	.750"	13	\$180
FTFT.4042	40"	42"	.750"	15	\$203
FTFT.4048	40"	48"	.750"	16	\$222

## DESCRIPTION &amp; NOTES

## NOTES:

- Tackable/acoustical surface.

**48" HIGH, TACKABLE/ACOUSTICAL**

PART #	HEIGHT	WIDTH	DEPTH	WT. (LBS)	PRICE
FTFT.4824	48"	24"	.750"	11	\$157
FTFT.4830	48"	30"	.750"	13	\$177
FTFT.4836	48"	36"	.750"	15	\$214
FTFT.4842	48"	42"	.750"	17	\$238
FTFT.4848	48"	48"	.750"	20	\$260

## DESCRIPTION &amp; NOTES

## NOTES:

- Tackable/acoustical surface.

## Beltline Power Access Tile

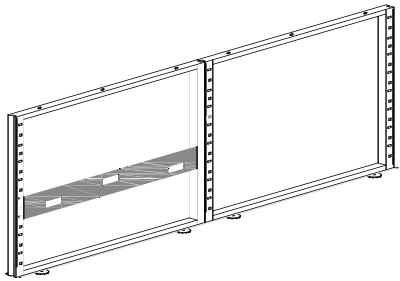

### DESCRIPTION

8"H tile attaches to one side of a frame of equal width, and has a fabric covered surface. Attachment hardware is included.

### NOTES

### SPECIFICATION OPTIONS

**product #:** see charts below  
**fabric color:** see fabrics, page 4  
**plastic finish:** LG Light Gray, BU Black Umber

### ORDER EXAMPLE

**product #:** FTBPA.0824  
**fabric color:** PF601-1 Passage-Gull  
**plastic finish:** LG Light Gray

### BELTLINE POWER ACCESS TILE

PART #	HEIGHT	WIDTH	DEPTH	WT. (LBS)	PRICE
FTBPA.0824	8"	24"	.750"	2	\$51
FTBPA.0830	8"	30"	.750"	3	\$59
FTBPA.0836	8"	36"	.750"	3	\$69
FTBPA.0842	8"	42"	.750"	4	\$76
FTBPA.0848	8"	48"	.750"	4	\$82

### DESCRIPTION & NOTES

**DESCRIPTION:**  
 This 8" tile attaches to one side of a frame and has cutouts for power.

- NOTES:**
- 24" and 30"W tiles have 1 power access.
  - 36", 42" and 48"W tiles have 2 power access.
  - To access power, order **Beltline Power Retro separately**
  - Cannot be used with **Wall Strips or Tile Adapters**.

### BELTLINE POWER AND DATA ACCESS TILE

PART #	HEIGHT	WIDTH	DEPTH	WT. (LBS)	PRICE
FTBPDA.0824	8"	24"	.750"	2	\$52
FTBPDA.0830	8"	30"	.750"	3	\$60
FTBPDA.0836	8"	36"	.750"	3	\$70
FTBPDA.0842	8"	42"	.750"	4	\$77
FTBPDA.0848	8"	48"	.750"	4	\$83

### DESCRIPTION & NOTES

**DESCRIPTION:**  
 This 8" tile attaches to one side of a frame and has cutouts for power and data.

- NOTES:**
- 24" and 30"W tiles have 1 power access.
  - 36", 42" and 48"W tiles have 2 power access.
  - To access power, order **Beltline Power Retro separately**
  - Cannot be used with **Wall Strips or Tile Adapters**
  - **Data Port** location is on the right side of the Power and Data Access Tile on 24" and 30"W frames, and at the center of the Power and Data Access Tile on 36", 42" and 48"W frames.
  - Order **Data Port Plate** separately.

### CABLE DISTRIBUTION TILE

PART #	HEIGHT	WIDTH	DEPTH	WT. (LBS)	PRICE
FTCDT.0818	8"	18"	.750"	2	\$45
FTCDT.0824	8"	24"	.750"	3	\$49
FTCDT.0830	8"	30"	.750"	3	\$57
FTCDT.0836	8"	36"	.750"	4	\$65
FTCDT.0842	8"	42"	.750"	4	\$72
FTCDT.0848	8"	48"	.750"	4	\$78

### DESCRIPTION & NOTES

**DESCRIPTION:**  
 This 8" tile attaches to one side of a frame and provides space for power and cable distribution.

- NOTES:**
- To pass power through tile, order **Beltline Power Retro**.



# Window Tile

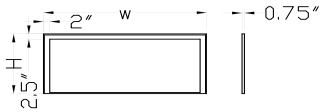
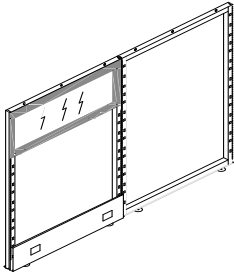

### DESCRIPTION

Window Tile attaches to one side of a frame of the same width.

### SPECIFICATION OPTIONS

**product #:** see charts below  
**tile glazing:** TR Clear, FR Frosted (check with factory for availability)  
**tile finish:** LG Light Gray, BU Black Umber

### NOTES

- Do not use with Wall Strips, Tile Adapter or Power Retro.
- To finish other side of the frame, order the same Window Tile Top.
- If you use a Window Tile with a Stacking Frame, order Window Tile Top only.

### ORDER EXAMPLE

**product #:** FTWTT.1624  
**tile glazing:** TR Clear  
**tile finish:** LG Light Gray

## WINDOW TILE TOP 16"H

PART #	HEIGHT	WIDTH	DEPTH	WT. (LBS)	PRICE
FTWTT.1624	16"	24"	.750"	9	\$100
FTWTT.1630	16"	30"	.750"	12	\$113
FTWTT.1636	16"	36"	.750"	14	\$126
FTWTT.1642	16"	42"	.750"	15	\$139
FTWTT.1648	16"	48"	.750"	16	\$151

### DESCRIPTION & NOTES

**DESCRIPTION:**  
 This Tile is used at the top of a frame.

- NOTES:**
- Specify Tile Trim finish.

## WINDOW TILE MIDDLE/BOTTOM 16"H

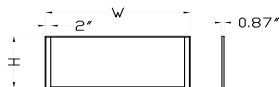
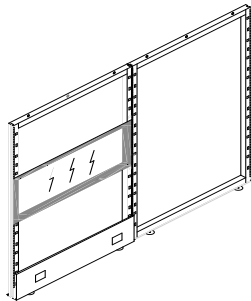

PART #	HEIGHT	WIDTH	DEPTH	WT. (LBS)	PRICE
FTWTM/B.1624	16"	24"	.750"	10	\$100
FTWTM/B.1630	16"	30"	.750"	13	\$113
FTWTM/B.1636	16"	36"	.750"	16	\$126
FTWTM/B.1642	16"	42"	.750"	18	\$139
FTWTM/B.1648	16"	48"	.750"	20	\$151

### DESCRIPTION & NOTES

**DESCRIPTION:**  
 This Tile is used anywhere below the top position only.

- NOTES:**
- Specify Tile Trim finish.

# Open Tile

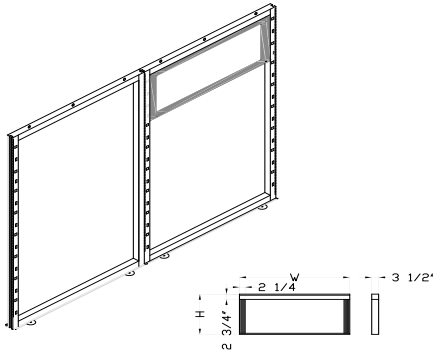

DESCRIPTION

Open Tile finishes a frame, and provides access for communication, or improving air circulation.

NOTES

- Do not use with a Stacking Frame or Power Jumper.
- One tile finishes both sides of a frame.

SPECIFICATION OPTIONS

**product #:** see charts below  
**tile finish, if applicable:** LG Light Gray, BU Black Umber

ORDER EXAMPLE

**product #:** FTOTT.1624  
**tile finish:** LG Light Gray

**OPEN TILE TOP  
16"H**

PART #	HEIGHT	WIDTH	DEPTH	WT. (LBS)	PRICE
FTOTT.1624	16"	24"	3.5"	5	\$123
FTOTT.1630	16"	30"	3.5"	6	\$136
FTOTT.1636	16"	36"	3.5"	7	\$149
FTOTT.1642	16"	42"	3.5"	8	\$163
FTOTT.1648	16"	48"	3.5"	8	\$176

DESCRIPTION & NOTES

DESCRIPTION:  
This Tile is used at the top of a frame.

NOTES:

- Do not use with a Stacking Frame or Power Jumper
- One tile finishes both sides of a frame.
- Specify Tiles Trim finish.

**OPEN TILE TOP  
32"H**

PART #	HEIGHT	WIDTH	DEPTH	WT. (LBS)	PRICE
FTOTT.3224	32"	24"	3.5"	7	\$161
FTOTT.3230	32"	30"	3.5"	8	\$174
FTOTT.3236	32"	36"	3.5"	10	\$187
FTOTT.3242	32"	42"	3.5"	12	\$200
FTOTT.3248	32"	48"	3.5"	14	\$213

DESCRIPTION & NOTES

DESCRIPTION:  
This Tile is used at the top of a frame.

NOTES:

- Do not use with a Stacking Frame or Power Jumper
- One tile finishes both sides of a frame.
- Specify Tiles Trim finish.

**OPEN TILE TOP  
48"H**

PART #	HEIGHT	WIDTH	DEPTH	WT. (LBS)	PRICE
FTOTT.4824	48"	24"	3.5"	10	\$206
FTOTT.4830	48"	30"	3.5"	12	\$218
FTOTT.4836	48"	36"	3.5"	14	\$231
FTOTT.4842	48"	42"	3.5"	16	\$243
FTOTT.4848	48"	48"	3.5"	17	\$256

DESCRIPTION & NOTES

DESCRIPTION:  
This Tile is used at the top of a frame.

NOTES:

- Do not use with a Stacking Frame or Power Jumper
- One tile finishes both sides of a frame.
- Specify Tiles Trim finish.

**OPEN TILE TOP  
64"H**

PART #	HEIGHT	WIDTH	DEPTH	WT. (LBS)	PRICE
FTOTT.6424	64"	24"	3.5"	11	\$259
FTOTT.6430	64"	30"	3.5"	13	\$274
FTOTT.6436	64"	36"	3.5"	16	\$289
FTOTT.6442	64"	42"	3.5"	18	\$304
FTOTT.6448	64"	48"	3.5"	20	\$319

DESCRIPTION & NOTES

DESCRIPTION:  
This Tile is used at the top of a frame.

NOTES:

- Do not use with a Stacking Frame or Power Jumper
- One tile finishes both sides of a frame.
- Specify Tiles Trim finish.

**OPEN TILE  
MIDDLE/BOTTOM  
16"H**

PART #	HEIGHT	WIDTH	DEPTH	WT. (LBS)	PRICE
FTOTM/B.1624	16"	24"	3.5"	5	\$107
FTOTM/B.1630	16"	30"	3.5"	6	\$114
FTOTM/B.1636	16"	36"	3.5"	7	\$122
FTOTM/B.1642	16"	42"	3.5"	8	\$129
FTOTM/B.1648	16"	48"	3.5"	8	\$136

**DESCRIPTION & NOTES**

**DESCRIPTION:**  
This Tile is used at the middle or bottom of a frame.

**NOTES:**

- Do not use with a Stacking Frame or Power Jumper
- One tile finishes both sides of a frame.
- Specify Tiles Trim finish.

**OPEN TILE  
MIDDLE/BOTTOM  
32"H**

PART #	HEIGHT	WIDTH	DEPTH	WT. (LBS)	PRICE
FTOTM/B.3224	32"	24"	3.5"	7	\$145
FTOTM/B.3230	32"	30"	3.5"	8	\$151
FTOTM/B.3236	32"	36"	3.5"	10	\$159
FTOTM/B.3242	32"	42"	3.5"	12	\$167
FTOTM/B.3248	32"	48"	3.5"	14	\$174

**DESCRIPTION & NOTES**

**DESCRIPTION:**  
This Tile is used at the middle or bottom of a frame.

**NOTES:**

- Do not use with a Stacking Frame or Power Jumper
- One tile finishes both sides of a frame.
- Specify Tiles Trim finish.

**OPEN TILE  
MIDDLE/BOTTOM  
48"H**

PART #	HEIGHT	WIDTH	DEPTH	WT. (LBS)	PRICE
FTOTM/B.4824	48"	24"	3.5"	10	\$189
FTOTM/B.4830	48"	30"	3.5"	12	\$196
FTOTM/B.4836	48"	36"	3.5"	14	\$203
FTOTM/B.4842	48"	42"	3.5"	16	\$209
FTOTM/B.4848	48"	48"	3.5"	17	\$217

**DESCRIPTION & NOTES**

**DESCRIPTION:**  
This Tile is used at the middle or bottom of a frame.

**NOTES:**

- Do not use with a Stacking Frame or Power Jumper
- One tile finishes both sides of a frame.
- Specify Tiles Trim finish.

## Perforated Metal Tile

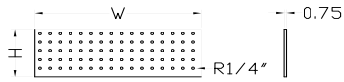
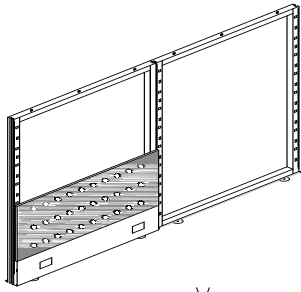

### DESCRIPTION

Perforated Metal Tile has round holes. It attaches to one side of a frame.

### NOTES

- Only available in Metallic Silver paint finish.

### SPECIFICATION OPTIONS

**product #:** see charts below  
**tile finish:** Metallic Silver

### ORDER EXAMPLE

**product #:** FTPMT.0818  
**tile finish:** Metallic Silver

### 8"H

PART #	HEIGHT	WIDTH	DEPTH	WT. (LBS)	PRICE
FTPMT.0818	8"	18"	.750"	2	\$35
FTPMT.0824	8"	24"	.750"	2	\$44
FTPMT.0830	8"	30"	.750"	3	\$49
FTPMT.0836	8"	36"	.750"	3	\$54
FTPMT.0842	8"	42"	.750"	4	\$59
FTPMT.0848	8"	48"	.750"	4	\$64

### 16"H

PART #	HEIGHT	WIDTH	DEPTH	WT. (LBS)	PRICE
FTPMT.1618	16"	18"	.750"	3	\$48
FTPMT.1624	16"	24"	.750"	4	\$60
FTPMT.1630	16"	30"	.750"	4	\$68
FTPMT.1636	16"	36"	.750"	4	\$77
FTPMT.1642	16"	42"	.750"	5	\$85
FTPMT.1648	16"	48"	.750"	6	\$94

# Rail Tile

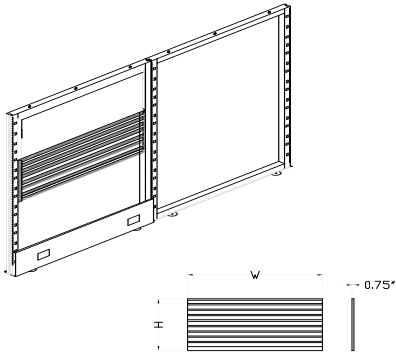

## DESCRIPTION

Rail Tile attaches to one side of a frame, or to Wall Strips.

## NOTES

- To finish other side of frame, order the same size tile.
- Attachment hardware is included.
- To attach Rail Tile to Wall strips, order Tile Adapters separately.
- **Order Rail Tools separately.**
- **Specify paint finish.**

## SPECIFICATION OPTIONS

**product #:** see charts below  
**tile finish:** LG Light Gray, BU Black Umber

## ORDER EXAMPLE

**product #:** FTRT.0824  
**tile finish:** LG Light Gray

### 8"H

PART #	HEIGHT	WIDTH	DEPTH	WT. (LBS)	PRICE
FTRT.0824	8"	24"	.750"	6	\$120
FTRT.0830	8"	30"	.750"	7	\$146
FTRT.0836	8"	36"	.750"	8	\$173
FTRT.0842	8"	42"	.750"	10	\$199
FTRT.0848	8"	48"	.750"	11	\$225

### 16"H

PART #	HEIGHT	WIDTH	DEPTH	WT. (LBS)	PRICE
FTRT.1624	16"	24"	.750"	11	\$239
FTRT.1630	16"	30"	.750"	14	\$292
FTRT.1636	16"	36"	.750"	16	\$347
FTRT.1642	16"	42"	.750"	19	\$400
FTRT.1648	16"	48"	.750"	23	\$453

# Tool Bar

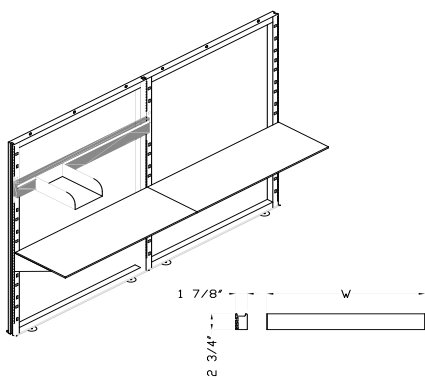

DESCRIPTION

Tool Bar attaches to a frame or to wall strips.

NOTES

- Specify Tool Bar width the same as the frame.
- Order Rail Tools separately.
- Specify paint finish.

SPECIFICATION OPTIONS

**product #:** see charts below  
**tile finish:** LG Light Gray, BU Black Umber

ORDER EXAMPLE

**product #:** FTTB.24  
**tile finish:** LG Light Gray

PART #	HEIGHT	WIDTH	DEPTH	WT. (LBS)	PRICE
FTTB.24	2.75"	24"		1	\$58
FTTB.30	2.75"	30"		1	\$70
FTTB.36	2.75"	36"		1	\$82
FTTB.42	2.75"	42"		2	\$94
FTTB.48	2.75"	48"		2	\$106

# Markerboard Tile

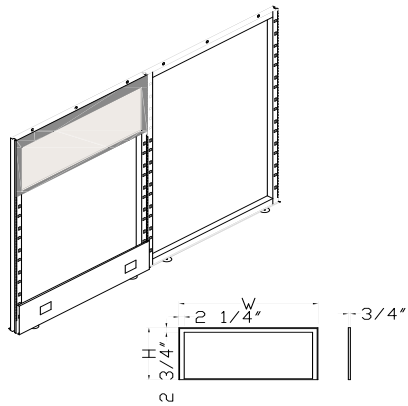

DESCRIPTION

Tile attaches to one side of a frame of the same width. Erasable writing surface.

NOTES

- Marker and eraser not included.
- Specify paint finish.

SPECIFICATION OPTIONS

**product #:** see charts below  
**tile finish, if applicable:** LG Light Gray, BU Black Umber

ORDER EXAMPLE

**product #:** FTMT.1624  
**tile finish:** LG Light Gray

**16"H**

PART #	HEIGHT	WIDTH	DEPTH	WT. (LBS)	PRICE
FTMT.1624	16"	24"	.750"	7	\$148
FTMT.1630	16"	30"	.750"	7	\$170
FTMT.1636	16"	36"	.750"	8	\$195
FTMT.1642	16"	42"	.750"	9	\$212
FTMT.1648	16"	48"	.750"	10	\$228

**32"H**

PART #	HEIGHT	WIDTH	DEPTH	WT. (LBS)	PRICE
FTMT.3224	32"	24"	.750"	13	\$237
FTMT.3230	32"	30"	.750"	13	\$274
FTMT.3236	32"	36"	.750"	16	\$317
FTMT.3242	32"	42"	.750"	18	\$342
FTMT.3248	32"	48"	.750"	21	\$367

## Electrical Distribution

### DESCRIPTION

### SPECIFICATION OPTIONS

**product #:** see charts below

**pole finish:** LG Light Gray, BU Black Umber

### NOTES

- 4-circuit

### ORDER EXAMPLE

**product #:** FTCPE

**pole finish:** LG Light Gray

### BASE POWER ENTRY DIRECT CONNECT 4-CIRCUIT

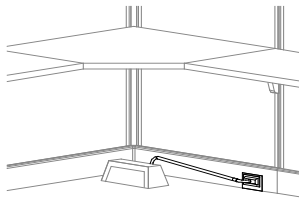

PART #	HEIGHT	WIDTH	DEPTH	WT. (LBS)	PRICE
FTBPE	—	—	—	5	\$276

### DESCRIPTION & NOTES

#### DESCRIPTION:

Connects building power from a wall, floor monument or a column to the base of a frame.

#### NOTES:

- Plugs directly into the panel's electrical harness at receptacle location.
- Distributes up to four 20-amp circuits.
- Includes a cable that can be field-cut to the appropriate length.
- **Must be wired by a licensed electrician.**

### CEILING POWER ENTRY INTERNAL DIRECT CONNECT 4-CIRCUIT

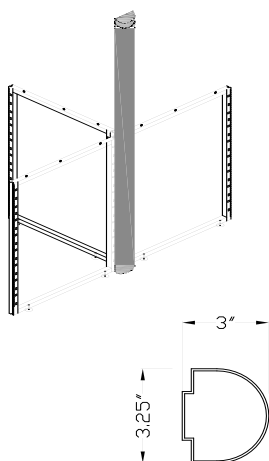

PART #	HEIGHT	WIDTH	DEPTH	WT. (LBS)	PRICE
FTCPE	14'	3.25"	3"	17	\$632

### DESCRIPTION & NOTES

#### DESCRIPTION:

Routes building power from the ceiling to the base of a powered frame.

#### NOTES:

- Connects a powered frame base to the 4-circuit power system at the end of a Power Retro.
- Distributes up to four 20-amp circuits.
- Attaches to the end of a frame or to a 2- or 3-Way connection.
- Includes a rigid conduit and conduit connector, factory installed 14' power harness, 12' pole. Top Trim is included.
- **When placing a Power Pole at a 2-Way connection, you must order a 3-Way connector. To use at a 3-Way connection, order a 4-Way connector.**
- **Power Pole cannot be placed at a 4-Way connection, nor in mid-frame.**
- **To attach at a 2-Way connection, order a 3-Way connector. To attach at a 3-Way connection, order a 4-Way connector.**
- **Must be wired by a licensed electrician.**



**RECEPTACLE 4-CIRCUITS**

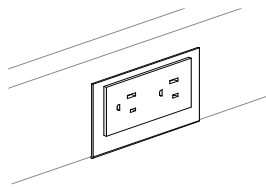

PART #	HEIGHT	WIDTH	DEPTH	WT. (LBS)	PRICE
FTRECP4.I	circuit I	—	—	0.25	\$28
FTRECP4.II	circuit II	—	—	0.25	\$28
FTRECP4.III	circuit III	—	—	0.25	\$28
FTRECP4.IIIII	circuit IIII (dedicated)	—	—	0.25	\$28

**DESCRIPTION & NOTES**

**DESCRIPTION:**  
Locks into panel base power harness.

Provides access to I, II, III, or IIII circuit.

Provides dedicated circuit with "IIII" receptacle.

**CEILING DATA ENTRY  
NON-POWERED**

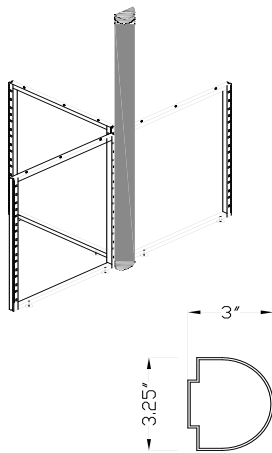

PART #	HEIGHT	WIDTH	DEPTH	WT. (LBS)	PRICE
FTCDE	14'	3.25"	3"	6	\$221

**DESCRIPTION & NOTES**

**DESCRIPTIONS:**  
Routes Data/Telecommunication cables from the ceiling to the base of a powered or non-powered frame.

Attaches to the end of a frame, to a 2- or 3-Way connection, or to a 3 and 4-Way 90° Connector.

Includes a 12' pole and top trim.

**NOTES:**

- When placing a Power Pole at a 2-Way connection, you must order a 3-Way connector.
- Power Pole cannot be placed at a 4-Way connection nor in mid-frame.
- To attach at a 2-Way connection, order a 3-Way connector.
- Power pole cannot be installed at a 4-Way connection.

**PASS-THROUGH FESTOON  
23" LONG 4-CIRCUIT**

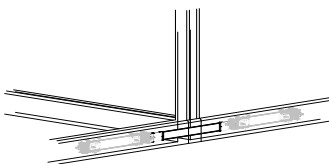

PART #	HEIGHT	WIDTH	DEPTH	WT. (LBS)	PRICE
FTPTF.23	—	23"	—	1	\$71

**DESCRIPTION & NOTES**

**DESCRIPTION:**  
Extends power in a straight line through a 3- or 4-Way Connector at the base of a frame.

**NOTES:**

- Not for use with beltline power.

## Electrical Distribution continued

### BELTLINE POWER RETRO

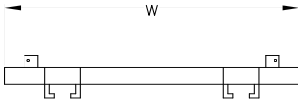
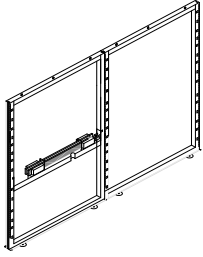

PART #	HEIGHT	WIDTH	DEPTH	WT. (LBS)	PRICE
FTBPR.18	—	18"	—	3	\$184
FTBPR.24	—	24"	—	3	\$184
FTBPR.30	—	30"	—	3	\$207
FTBPR.36	—	36"	—	4	\$237
FTBPR.42	—	42"	—	4	\$268
FTBPR.48	—	48"	—	5	\$297

### DESCRIPTION & NOTES

#### DESCRIPTION:

This Beltline Power Retro is used to access power and data above the worksurface level. It distributes up to 4 20-amp circuits, and provides duplex locations on both sides of a frame.

Support Bar, Frame to Frame Festoon, and Attachment hardware is included.

#### NOTES:

- 18"W Power Retro has no power access, 24" and 30"W have 1 duplex location per side.
- 36", 42", and 48"W power retro have 2 duplex locations per side.
- To connect power from a Base Power Retro to a Beltline Power Retro within the same frame, order 1 In Frame Power Jumper.

### IN FRAME POWER JUMPER

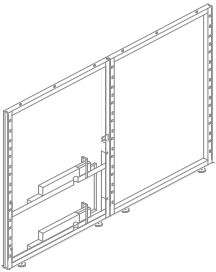

PART #	HEIGHT	WIDTH	DEPTH	WT. (LBS)	PRICE
FTIFPJ	—	—	—	2	\$160

### DESCRIPTION & NOTES

#### DESCRIPTION:

In Frame Power Jumper is used to connect power from the Base Power to the Beltline Power. It connects at the Base Power Retro.

#### NOTES:

- In Frame Power Jumper cannot be used with a Window Tile, Open Tile, or Stacking Frame.

### PASS-THROUGH POWER JUMPER

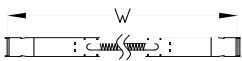
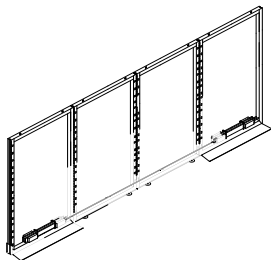

PART #	HEIGHT	WIDTH	DEPTH	WT. (LBS)	PRICE
FTPTPJ.18	—	18"	—	1	\$73
FTPTPJ.24	—	24"	—	2	\$97
FTPTPJ.30	—	30"	—	2	\$120
FTPTPJ.36	—	36"	—	3	\$135
FTPTPJ.42	—	42"	—	3	\$160
FTPTPJ.48	—	48"	—	4	\$183
FTPTPJ.60	—	60"	—	4	\$234

### DESCRIPTION & NOTES

#### DESCRIPTION:

Pass-through power jumper is used to extend power from a powered frame through a non-powered frame, to an adjacent powered frame.

#### NOTES:

- In Frame Power Jumper cannot be used with a Window Tile, Open Tile, or Stacking Frame.

**BELTLINE POWER TRANSFER**

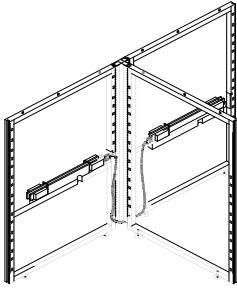

PART #	HEIGHT	WIDTH	DEPTH	WT. (LBS)	PRICE
FTBPT	—	—	—	4	\$297

**DESCRIPTION & NOTES**

**DESCRIPTION:**  
 This Power Transfer is used to extend power through a 3- or 4-Way Connector at beltline level. It connects to the Beltline Power Retro on either side of the connector, and takes the place of the festoon.

- NOTES:**
- Power Jumper cannot be used with a Window Tile, Open Tile or Stacking Frame.
  - Connects to Power Retro on one side, drops down to the base of the connector and back up the other side to connect to the Power Retro.

**DATA PORT PLATE**

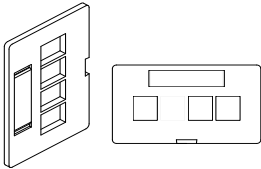

PART #	HEIGHT	WIDTH	DEPTH	WT. (LBS)	PRICE
FTDPP	2.125"	3.625"	—	1	\$32

**DESCRIPTION & NOTES**

**DESCRIPTION:**  
 This Data Port Plate is used at the base of a frame, or above the worksurfaces, to connect computers and/or communication equipment. It has 4 port locations, and comes with 1 blank insert.

- NOTES:**
- For use with Powered Frame with Data and Duplex Cutout, and Beltline Power and Data access tiles.

# Rectangular Worksurface

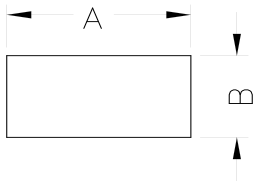
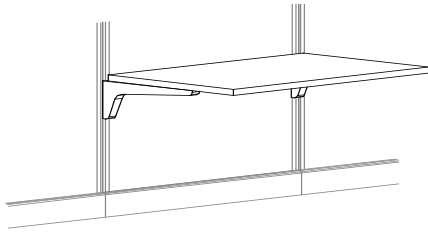

**DESCRIPTION**

Worksurface hangs from a frame or wall strip. It has a laminate top, and a PVC edge. There is a 1" gap at the back of the worksurface for plug and cord passage.

**NOTES**

- 60" to 84" worksurfaces have a center support
- Includes cantilever brackets, and attachment hardware.
- When ordering a worksurface spanning a panel and a 3-Way or spacer connector, or 2 panels with a 3-Way or spacer connector in between the panels, you need to add 3.5" to the length of the worksurface, add -3W to the part number and add \$80 to the list price. Example: Two 30"W frames + one 3-Way connector = 63.5". Use FTRWS.2460L-3W (\$408 + \$80 = \$488)

**SPECIFICATION OPTIONS**

**product #:** see charts below  
**top edge finish:** see edge finishes, page 4  
**support finish:** LG Light Gray, BU Black Umber  
**laminate finish:** see laminates, page 4

**ORDER EXAMPLE**

**product #:** FTRWS.2424L  
**top edge finish:** LG Light Gray  
**support finish:** LG Light Gray  
**laminate finish:** Light Maple

**24"D WORKSURFACE**

PART #	HEIGHT	A	B	C	D	WT. (LBS)	PRICE
FTRWS.2424L	1.25"	24"	24"	—	—	30	\$215
FTRWS.2430L	1.25"	30"	24"	—	—	36	\$251
FTRWS.2436L	1.25"	36"	24"	—	—	41	\$257
FTRWS.2442L	1.25"	42"	24"	—	—	47	\$325
FTRWS.2448L	1.25"	48"	24"	—	—	53	\$331
FTRWS.2454L	1.25"	54"	24"	—	—	58	\$384
FTRWS.2460L	1.25"	60"	24"	—	—	64	\$408
FTRWS.2466L	1.25"	66"	24"	—	—	70	\$462
FTRWS.2472L	1.25"	72"	24"	—	—	76	\$470
FTRWS.2478L	1.25"	78"	24"	—	—	81	\$566
FTRWS.2484L	1.25"	84"	24"	—	—	87	\$570

**30"D WORKSURFACE**

PART #	HEIGHT	A	B	C	D	WT. (LBS)	PRICE
FTRWS.3024L	1.25"	24"	30"	—	—	38	\$280
FTRWS.3030L	1.25"	30"	30"	—	—	45	\$328
FTRWS.3036L	1.25"	36"	30"	—	—	53	\$333
FTRWS.3042L	1.25"	42"	30"	—	—	60	\$414
FTRWS.3048L	1.25"	48"	30"	—	—	66	\$420
FTRWS.3054L	1.25"	54"	30"	—	—	74	\$485
FTRWS.3060L	1.25"	60"	30"	—	—	81	\$510
FTRWS.3066L	1.25"	66"	30"	—	—	88	\$576
FTRWS.3072L	1.25"	72"	30"	—	—	95	\$585
FTRWS.3078L	1.25"	78"	30"	—	—	103	\$704

## Rectangular Worksurface Connector Spanning

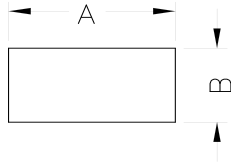
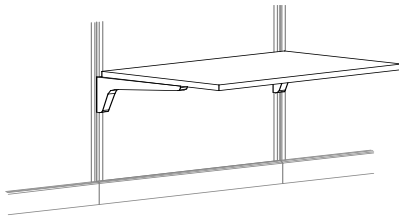

### DESCRIPTION

Worksurface hangs from a frame or wall strip. It has a laminate top, and a PVC edge. There is a 1" gap at the back of the worksurface for plug and cord passage.

### NOTES

- 60" to 84" worksurfaces have a center support
- Includes cantilever brackets, and attachment hardware.

### SPECIFICATION OPTIONS

**product #:** see charts below  
**top edge finish:** see edge finishes, page 4  
**support finish:** LG Light Gray, BU Black Umber  
**laminate finish:** see laminates, page 4

### ORDER EXAMPLE

**product #:** FTRWS.2424L-3W  
**top edge finish:** Light Maple  
**support finish:** LG Light Gray  
**laminate finish:** Light Maple

### 24"D WORKSURFACE

PART #	HEIGHT	A	B	C	D	WT. (LBS)	PRICE
FTRWS.2424L-3W	1.25"	27.5"	24"	—	—	30	\$290
FTRWS.2430L-3W	1.25"	33.5"	24"	—	—	36	\$331
FTRWS.2436L-3W	1.25"	39.5"	24"	—	—	41	\$337
FTRWS.2442L-3W	1.25"	45.5"	24"	—	—	47	\$405
FTRWS.2448L-3W	1.25"	51.5"	24"	—	—	53	\$411
FTRWS.2454L-3W	1.25"	57.5"	24"	—	—	58	\$464
FTRWS.2460L-3W	1.25"	63.5"	24"	—	—	64	\$488
FTRWS.2466L-3W	1.25"	69.5"	24"	—	—	70	\$542
FTRWS.2472L-3W	1.25"	75.5"	24"	—	—	76	\$550
FTRWS.2478L-3W	1.25"	81.5"	24"	—	—	81	\$646
FTRWS.2484L-3W	1.25"	87.5"	24"	—	—	87	\$650

### 30"D WORKSURFACE

PART #	HEIGHT	A	B	C	D	WT. (LBS)	PRICE
FTRWS.3024L-3W	1.25"	27.5"	30"	—	—	38	\$360
FTRWS.3030L-3W	1.25"	33.5"	30"	—	—	45	\$408
FTRWS.3036L-3W	1.25"	39.5"	30"	—	—	53	\$413
FTRWS.3042L-3W	1.25"	45.5"	30"	—	—	60	\$494
FTRWS.3048L-3W	1.25"	51.5"	30"	—	—	66	\$500
FTRWS.3054L-3W	1.25"	57.5"	30"	—	—	74	\$545
FTRWS.3060L-3W	1.25"	63.5"	30"	—	—	81	\$590
FTRWS.3066L-3W	1.25"	69.5"	30"	—	—	88	\$656
FTRWS.3072L-3W	1.25"	75.5"	30"	—	—	95	\$665
FTRWS.3078L-3W	1.25"	81.5"	30"	—	—	103	\$784
FTRWS.3084L-3W	1.25"	87.5"	30"	—	—	110	\$787

## 90° Notched and Curved Worksurface

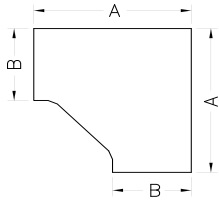
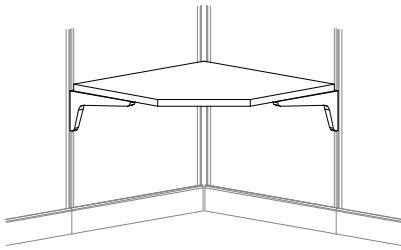

### DESCRIPTION

Worksurface hangs from frames or wall strip. It has a laminate top and a PVC edge. There is a 1" gap at the back of the worksurface for plug and cord passage. It has 24"D or 30"D connecting sides.

### NOTES

- Includes cantilever brackets, one corner bracket and attachment hardware.
- Includes one wire grommet.

### SPECIFICATION OPTIONS

**product #:** see charts below  
**top edge finish:** see edge finishes, page 4  
**support finish:** LG Light Gray, BU Black Umber  
**laminate finish:** see laminates, page 4

### ORDER EXAMPLE

**product #:** FTCWS.2436L  
**top edge finish:** LG Light Gray  
**support finish:** LG Light Gray  
**laminate finish:** Light Maple

### 90° NOTCHED CORNER

PART #	HEIGHT	A	B	C	D	WT. (LBS)	PRICE	DESCRIPTION & NOTES
FTCWS.2436L	1.25"	*36"	24"	—	—	53	\$438	*Corners are not available with notched front edge
FTCWS.2442L	1.25"	42"	24"	—	—	72	\$548	
FTCWS.2448L	1.25"	48"	24"	—	—	83	\$570	
FTCWS.3036L	1.25"	*36"	30"	—	—	60	\$474	
FTCWS.3042L	1.25"	*42"	30"	—	—	74	\$584	
FTCWS.3048L	1.25"	48"	30"	—	—	85	\$606	

### 90° CURVED CORNER

PART #	HEIGHT	A	B	C	D	WT. (LBS)	PRICE	DESCRIPTION & NOTES
FTCCWS.2436L	1.25"	36"	24"	—	—	54	\$438	
FTCCWS.2442L	1.25"	42"	24"	—	—	68	\$548	
FTCCWS.2448L	1.25"	48"	24"	—	—	72	\$570	
FTCCWS.3042L	1.25"	36"	30"	—	—	60	\$474	
FTCCWS.3042L	1.25"	42"	30"	—	—	76	\$584	
FTCCWS.3048L	1.25"	48"	30"	—	—	78	\$606	

# Square Edge Half Circle Worksurface

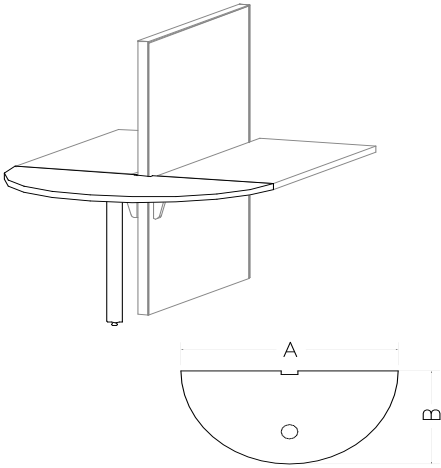

**DESCRIPTION**

This Half Circle Worksurface has a notch, and attaches to the end of two back-to-back rectangular or Extended Corner Worksurfaces, and includes one Support Column Leg. It has a laminate top and a PVC edge.

**NOTES**

- The notch allows for a flush fit at the end of the worksurfaces.
- Support column leg has a leveling glide and attaching hardware.
- Ships unassembled.
- Column leg finish: DT Dark Tone only.

**SPECIFICATION OPTIONS**

**product #:** see charts below  
**top edge finish:** see edge finishes, page 4  
**support finish:** LG Light Gray, BU Black Umber  
**laminate finish:** see laminates, page 4  
**column leg finish:** DT Dark Tone only

**ORDER EXAMPLE**

**product #:** FTEHCWS.50L  
**top edge finish:** LG Light Gray  
**support finish:** LG Light Gray  
**laminate finish:** Light Maple  
**column leg finish:** DT Dark Tone

**SQUARE EDGE HALF CIRCLE WORKSURFACE**

PART #	HEIGHT	A	B	C	D	WT. (LBS)	PRICE
FTEHCWS.50L	1.25"	52"	26"	—	—	55	\$620
FTEHCWS.60L	1.25"	64"	32"	—	—	67	\$700

## Square Edge D-Shaped Peninsula Worksurface

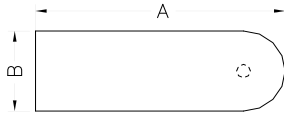
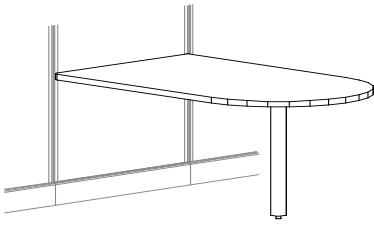

### DESCRIPTION

Worksurface hangs from frames or wall strip. It has a laminate top and a PVC edge. There is a 1" gap at the back of the worksurface for plug and cord passage.

### NOTES

- Includes one support column leg, which has leveling glide and attaching hardware.
- Ships unassembled.
- **Column leg finish: DT Dark Tone only.**

### SPECIFICATION OPTIONS

**product #:** see charts below  
**top edge finish:** see edge finishes, page 4  
**support finish:** LG Light Gray, BU Black Umber  
**laminate finish:** see laminates, page 4  
**column leg finish:** DT Dark Tone only

### ORDER EXAMPLE

**product #:** FTEDSP.2448L  
**top edge finish:** LG Light Gray  
**support finish:** LG Light Gray  
**laminate finish:** Light Maple  
**column leg finish:** DT Dark Tone

### SQUARE EDGE D-SHAPED PENINSULA WORKSURFACE

PART #	HEIGHT	A	B	C	D	WT. (LBS)	PRICE
FTEDSP.2448L	1.25"	48"	24"	—	—	62	\$443
FTEDSP.3048L	1.25"	48"	30"	—	—	72	\$494
FTEDSP.2460L	1.25"	60"	24"	—	—	73	\$502
FTEDSP.3060L	1.25"	60"	30"	—	—	87	\$559
FTEDSP.3072L	1.25"	72"	30"	—	—	101	\$622
FTEDSP.3672L	1.25"	72"	36"	—	—	117	\$697



# 90° Extended Notched Corner Worksurface

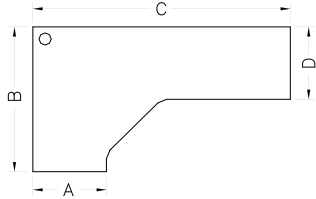
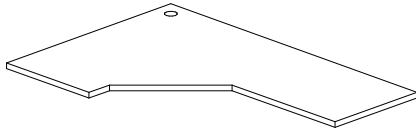

right extended shown

DESCRIPTION

Worksurface hangs from a frame or wall strips. It has a laminate top and a PVC edge. There is a 1" gap at the back of the worksurface for plug and cord passage.

NOTES

- 60" to 84" worksurfaces have a center support.
- Includes cantilever brackets, one corner bracket, and attachment hardware.
- Specify L for Left Extended and R for Right Extended.
- When ordering a worksurface spanning a panel and a 3-Way or spacer connector, or 2 panels with a 3-Way or spacer connector in between the panels, you need to add 3.5" to the length of the worksurface, add -3W to the part number and add \$80 to the list price. Example: Two 30"W frames + one 3-Way connector = 63.5". Use FTENCWS.24366024L-3W (\$548 + \$80 = \$628)

SPECIFICATION OPTIONS

**product #:** see charts below  
**top edge finish:** see edge finishes, page 4  
**support finish:** LG Light Gray, BU Black Umber  
**laminate finish:** see laminates, page 4  
**left or right extended:** L left, R right

ORDER EXAMPLE

**product #:** FENCWS.24366024L  
**top edge finish:** LG Light Gray  
**support finish:** LG Light Gray  
**laminate finish:** Light Maple  
**left or right extended:** L left

24"D CONNECTING SIDE  
 24"D EXTENSION  
 36"D

PART #	HEIGHT	A	B	C	D	WT. (LBS)	PRICE
FTENCWS.24366024L	1.25"	24"	36"	60"	24"	74	\$548
FTENCWS.24366024R	1.25"	24"	36"	60"	24"	74	\$548
FTENCWS.24366624L	1.25"	24"	36"	66"	24"	81	\$621
FTENCWS.24366624R	1.25"	24"	36"	66"	24"	81	\$621
FTENCWS.24367224L	1.25"	24"	36"	72"	24"	87	\$628
FTENCWS.24367224R	1.25"	24"	36"	72"	24"	87	\$628
FTENCWS.24367824L	1.25"	24"	36"	78"	24"	93	\$772
FTENCWS.24367824R	1.25"	24"	36"	78"	24"	93	\$772
FTENCWS.24368424L	1.25"	24"	36"	84"	24"	99	\$777
FTENCWS.24368424R	1.25"	24"	36"	84"	24"	99	\$777

## 90° Extended Notched Corner Worksurface continued

30"D CONNECTING SIDE  
30"D EXTENSION  
36"D

PART #	HEIGHT	A	B	C	D	WT. (LBS)	PRICE
FTENCWS.30366030L	1.25"	30"	36"	60"	30"	88	\$588
FTENCWS.30366030R	1.25"	30"	36"	60"	30"	88	\$588
FTENCWS.30366630L	1.25"	30"	36"	66"	30"	95	\$661
FTENCWS.30366630R	1.25"	30"	36"	66"	30"	95	\$661
FTENCWS.30367230L	1.25"	30"	36"	72"	30"	102	\$668
FTENCWS.30367230R	1.25"	30"	36"	72"	30"	102	\$668
FTENCWS.30367830L	1.25"	30"	36"	78"	30"	110	\$812
FTENCWS.30367830R	1.25"	30"	36"	78"	30"	110	\$812
FTENCWS.30368430L	1.25"	30"	36"	84"	30"	117	\$817
FTENCWS.30368430R	1.25"	30"	36"	84"	30"	117	\$817

24"D CONNECTING SIDE  
24"D EXTENSION  
42"D

PART #	HEIGHT	A	B	C	D	WT. (LBS)	PRICE
FTENCWS.24426024L	1.25"	24"	42"	60"	24"	84	\$674
FTENCWS.24426024R	1.25"	24"	42"	60"	24"	84	\$674
FTENCWS.24426624L	1.25"	24"	42"	66"	24"	91	\$770
FTENCWS.24426624R	1.25"	24"	42"	66"	24"	91	\$770
FTENCWS.24427224L	1.25"	24"	42"	72"	24"	97	\$778
FTENCWS.24427224R	1.25"	24"	42"	72"	24"	97	\$778
FTENCWS.24427824L	1.25"	24"	42"	78"	24"	103	\$966
FTENCWS.24427824R	1.25"	24"	42"	78"	24"	103	\$966
FTENCWS.24428424L	1.25"	24"	42"	84"	24"	109	\$974
FTENCWS.24428424R	1.25"	24"	42"	84"	24"	109	\$974

30"D CONNECTING SIDE  
30"D EXTENSION  
42"D

PART #	HEIGHT	A	B	C	D	WT. (LBS)	PRICE
FTENCWS.30426030L	1.25"	30"	42"	60"	30"	98	\$714
FTENCWS.30426030R	1.25"	30"	42"	60"	30"	98	\$714
FTENCWS.30426630L	1.25"	30"	42"	66"	30"	106	\$810
FTENCWS.30426630R	1.25"	30"	42"	66"	30"	106	\$810
FTENCWS.30427230L	1.25"	30"	42"	72"	30"	112	\$817
FTENCWS.30427230R	1.25"	30"	42"	72"	30"	112	\$817
FTENCWS.30427830L	1.25"	30"	42"	78"	30"	122	\$1,006
FTENCWS.30427830R	1.25"	30"	42"	78"	30"	122	\$1,006
FTENCWS.30428430L	1.25"	30"	42"	84"	30"	127	\$1,014
FTENCWS.30428430R	1.25"	30"	42"	84"	30"	127	\$1,014

**24"D CONNECTING SIDE  
24"D EXTENSION  
48"D**

PART #	HEIGHT	A	B	C	D	WT. (LBS)	PRICE
FTENCWS.24486024L	1.25"	24"	48"	60"	24"	93	\$682
FTENCWS.24486024R	1.25"	24"	48"	60"	24"	93	\$682
FTENCWS.24486624L	1.25"	24"	48"	66"	24"	99	\$778
FTENCWS.24486624R	1.25"	24"	48"	66"	24"	99	\$778
FTENCWS.24487224L	1.25"	24"	48"	72"	24"	104	\$790
FTENCWS.24487224R	1.25"	24"	48"	72"	24"	104	\$790
FTENCWS.24487824L	1.25"	24"	48"	78"	24"	110	\$984
FTENCWS.24487824R	1.25"	24"	48"	78"	24"	110	\$984
FTENCWS.24488424L	1.25"	24"	48"	84"	24"	116	\$988
FTENCWS.24488424R	1.25"	24"	48"	84"	24"	116	\$988

**30"D CONNECTING SIDE  
30"D EXTENSION  
48"D**

PART #	HEIGHT	A	B	C	D	WT. (LBS)	PRICE
FTENCWS.30486030L	1.25"	30"	48"	60"	30"	108	\$721
FTENCWS.30486030R	1.25"	30"	48"	60"	30"	108	\$721
FTENCWS.30486630L	1.25"	30"	48"	66"	30"	116	\$819
FTENCWS.30486630R	1.25"	30"	48"	66"	30"	116	\$819
FTENCWS.30487230L	1.25"	30"	48"	72"	30"	123	\$830
FTENCWS.30487230R	1.25"	30"	48"	72"	30"	123	\$830
FTENCWS.30487830L	1.25"	30"	48"	78"	30"	134	\$1,024
FTENCWS.30487830R	1.25"	30"	48"	78"	30"	134	\$1,024
FTENCWS.30488430L	1.25"	30"	48"	84"	30"	146	\$1,027
FTENCWS.30488430R	1.25"	30"	48"	84"	30"	146	\$1,027

## 90° Extended Curved Corner Worksurface

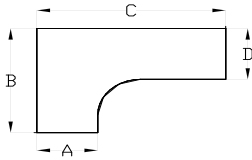

right extended shown

### DESCRIPTION

Worksurface hangs from a frame or wall strips. It has a laminate top and a PVC edge. There is a 1" gap at the back of the worksurface for plug and cord passage.

### NOTES

- 60" to 84" worksurfaces have a center support.
- Includes cantilever brackets, one corner bracket, and attachment hardware.
- Specify L for Left Extended and R for Right Extended.
- When ordering a worksurface spanning a panel and a 3-Way or spacer connector, or 2 panels with a 3-Way or spacer connector in between the panels, you need to add 3.5" to the length of the worksurface, add -3W to the part number and add \$80 to the list price. Example: Two 30"W frames + one 3-Way connector = 63.5". Use FTECCWS.24366024L (\$548 + \$80 = \$628)

### SPECIFICATION OPTIONS

**product #:** see charts below  
**top edge finish:** see edge finishes, page 4  
**support finish:** LG Light Gray, BU Black Umber  
**laminate finish:** see laminates, page 4  
**left or right extended:** L left, R right

### ORDER EXAMPLE

**product #:** FTECCWS.24366024L  
**top edge finish:** LG Light Gray  
**support finish:** LG Light Gray  
**laminate finish:** Light Maple  
**left or right extended:** L left

### 24"D CONNECTING SIDE 24"D EXTENSION 36"D

PART #	HEIGHT	A	B	C	D	WT. (LBS)	PRICE
FTECCWS.24366024L	1.25"	24"	36"	60"	24"	76	\$548
FTECCWS.24366024R	1.25"	24"	36"	60"	24"	76	\$548
FTECCWS.24366624L	1.25"	24"	36"	66"	24"	82	\$621
FTECCWS.24366624R	1.25"	24"	36"	66"	24"	82	\$621
FTECCWS.24367224L	1.25"	24"	36"	72"	24"	88	\$628
FTECCWS.24367224R	1.25"	24"	36"	72"	24"	88	\$628
FTECCWS.24367824L	1.25"	24"	36"	78"	24"	94	\$772
FTECCWS.24367824R	1.25"	24"	36"	78"	24"	94	\$772
FTECCWS.24368424L	1.25"	24"	36"	84"	24"	100	\$777
FTECCWS.24368424R	1.25"	24"	36"	84"	24"	100	\$777

**30"D CONNECTING SIDE  
30"D EXTENSION  
36"D**

PART #	HEIGHT	A	B	C	D	WT. (LBS)	PRICE
FTECCWS.30366030L	1.25"	30"	36"	60"	30"	87	\$588
FTECCWS.30366030R	1.25"	30"	36"	60"	30"	87	\$588
FTECCWS.30366630L	1.25"	30"	36"	66"	30"	95	\$661
FTECCWS.30366630R	1.25"	30"	36"	66"	30"	95	\$661
FTECCWS.30367230L	1.25"	30"	36"	72"	30"	102	\$668
FTECCWS.30367230R	1.25"	30"	36"	72"	30"	102	\$668
FTECCWS.30367830L	1.25"	30"	36"	78"	30"	110	\$812
FTECCWS.30367830R	1.25"	30"	36"	78"	30"	110	\$812
FTECCWS.30368430L	1.25"	30"	36"	84"	30"	117	\$817
FTECCWS.30368430R	1.25"	30"	36"	84"	30"	117	\$817

**24"D CONNECTING SIDE  
24"D EXTENSION  
42"D**

PART #	HEIGHT	A	B	C	D	WT. (LBS)	PRICE
FTECCWS.24426024L	1.25"	24"	42"	60"	24"	83	\$674
FTECCWS.24426024R	1.25"	24"	42"	60"	24"	83	\$674
FTECCWS.24426624L	1.25"	24"	42"	66"	24"	89	\$770
FTECCWS.24426624R	1.25"	24"	42"	66"	24"	89	\$770
FTECCWS.24427224L	1.25"	24"	42"	72"	24"	95	\$778
FTECCWS.24427224R	1.25"	24"	42"	72"	24"	95	\$778
FTECCWS.24427824L	1.25"	24"	42"	78"	24"	101	\$966
FTECCWS.24427824R	1.25"	24"	42"	78"	24"	101	\$966
FTECCWS.24428424L	1.25"	24"	42"	84"	24"	106	\$974
FTECCWS.24428424R	1.25"	24"	42"	84"	24"	106	\$974

**30"D CONNECTING SIDE  
30"D EXTENSION  
42"D**

PART #	HEIGHT	A	B	C	D	WT. (LBS)	PRICE
FTECCWS.30426030L	1.25"	30"	42"	60"	30"	95	\$714
FTECCWS.30426030R	1.25"	30"	42"	60"	30"	95	\$714
FTECCWS.30426630L	1.25"	30"	42"	66"	30"	103	\$810
FTECCWS.30426630R	1.25"	30"	42"	66"	30"	103	\$810
FTECCWS.30427230L	1.25"	30"	42"	72"	30"	110	\$817
FTECCWS.30427230R	1.25"	30"	42"	72"	30"	110	\$817
FTECCWS.30427830L	1.25"	30"	42"	78"	30"	118	\$1,006
FTECCWS.30427830R	1.25"	30"	42"	78"	30"	118	\$1,006
FTECCWS.30428430L	1.25"	30"	42"	84"	30"	125	\$1,014
FTECCWS.30428430R	1.25"	30"	42"	84"	30"	125	\$1,014

**90° Extended Curved Corner Worksurface** continued**24"D CONNECTING SIDE  
24"D EXTENSION  
48"D**

PART #	HEIGHT	A	B	C	D	WT. (LBS)	PRICE
FTECCWS.24486024L	1.25"	24"	48"	60"	24"	89	\$682
FTECCWS.24486024R	1.25"	24"	48"	60"	24"	89	\$682
FTECCWS.24486624L	1.25"	24"	48"	66"	24"	95	\$778
FTECCWS.24486624R	1.25"	24"	48"	66"	24"	95	\$778
FTECCWS.24487224L	1.25"	24"	48"	72"	24"	101	\$790
FTECCWS.24487224R	1.25"	24"	48"	72"	24"	101	\$790
FTECCWS.24487824L	1.25"	24"	48"	78"	24"	107	\$984
FTECCWS.24487824R	1.25"	24"	48"	78"	24"	107	\$984
FTECCWS.24488424L	1.25"	24"	48"	84"	24"	112	\$988
FTECCWS.24488424R	1.25"	24"	48"	84"	24"	112	\$988

**30"D CONNECTING SIDE  
30"D EXTENSION  
48"D**

PART #	HEIGHT	A	B	C	D	WT. (LBS)	PRICE
FTECCWS.30486030L	1.25"	30"	48"	60"	30"	104	\$721
FTECCWS.30486030R	1.25"	30"	48"	60"	30"	104	\$721
FTECCWS.30486630L	1.25"	30"	48"	66"	30"	112	\$817
FTECCWS.30486630R	1.25"	30"	48"	66"	30"	112	\$817
FTECCWS.30487230L	1.25"	30"	48"	72"	30"	119	\$830
FTECCWS.30487230R	1.25"	30"	48"	72"	30"	119	\$830
FTECCWS.30487830L	1.25"	30"	48"	78"	30"	126	\$1,024
FTECCWS.30487830R	1.25"	30"	48"	78"	30"	126	\$1,024
FTECCWS.30488430L	1.25"	30"	48"	84"	30"	133	\$1,027
FTECCWS.30488430R	1.25"	30"	48"	84"	30"	133	\$1,027

## 90° Extended Notched Corner Peninsula Worksurface

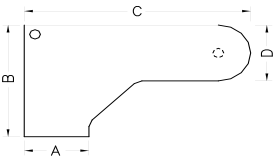
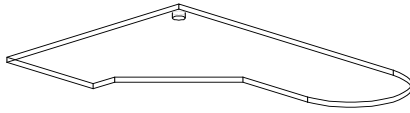

right extended shown

### DESCRIPTION

Worksurface hangs from a frame or wall strips. It has a laminate top and a PVC edge. There is a 1" gap at the back of the worksurface for plug and cord passage.

### NOTES

- Includes one support column leg, one wire grommet, cantilever brackets, one corner bracket and attachment hardware.
- Specify L for Left Extended and R for Right Extended.

### SPECIFICATION OPTIONS

**product #:** see charts below  
**top edge finish:** see edge finishes, page 4  
**support finish:** LG Light Gray, BU Black Umber  
**laminate finish:** see laminates, page 4  
**left or right extended:** L left, R right  
**column leg finish:** DT Dark Tone only

### ORDER EXAMPLE

**product #:** FTENCPWS.24366024L  
**top edge finish:** LG Light Gray  
**support finish:** LG Light Gray  
**laminate finish:** Light Maple  
**left or right extended:** L left  
**column leg finish:** DT Dark Tone

### 24"D CONNECTING SIDE 24"D EXTENSION 36"D

PART #	HEIGHT	A	B	C	D	WT. (LBS)	PRICE
FTENCPWS.24366024L	1.25"	24"	36"	60"	24"	89	\$695
FTENCPWS.24366024R	1.25"	24"	36"	60"	24"	89	\$695
FTENCPWS.24366624L	1.25"	24"	36"	66"	24"	95	\$776
FTENCPWS.24366624R	1.25"	24"	36"	66"	24"	95	\$776
FTENCPWS.24367224L	1.25"	24"	36"	72"	24"	101	\$788
FTENCPWS.24367224R	1.25"	24"	36"	72"	24"	101	\$788
FTENCPWS.24367824L	1.25"	24"	36"	78"	24"	107	\$940
FTENCPWS.24367824R	1.25"	24"	36"	78"	24"	107	\$940
FTENCPWS.24368424L	1.25"	24"	36"	84"	24"	112	\$955
FTENCPWS.24368424R	1.25"	24"	36"	84"	24"	112	\$955

### 24"D CONNECTING SIDE 24"D EXTENSION 42"D

PART #	HEIGHT	A	B	C	D	WT. (LBS)	PRICE
FTENCPWS.24426024L	1.25"	24"	42"	60"	24"	97	\$814
FTENCPWS.24426024R	1.25"	24"	42"	60"	24"	97	\$814
FTENCPWS.24426624L	1.25"	24"	42"	66"	24"	103	\$918
FTENCPWS.24426624R	1.25"	24"	42"	66"	24"	103	\$918
FTENCPWS.24427224L	1.25"	24"	42"	72"	24"	109	\$930
FTENCPWS.24427224R	1.25"	24"	42"	72"	24"	109	\$930
FTENCPWS.24427824L	1.25"	24"	42"	78"	24"	114	\$1,152
FTENCPWS.24427824R	1.25"	24"	42"	78"	24"	114	\$1,152
FTENCPWS.24428424L	1.25"	24"	42"	84"	24"	120	\$1,155
FTENCPWS.24428424R	1.25"	24"	42"	84"	24"	120	\$1,155

## 90° Extended Notched Corner Peninsula Worksurface continued

24"D CONNECTING SIDE  
24"D EXTENSION  
48"D

PART #	HEIGHT	A	B	C	D	WT. (LBS)	PRICE
FTENCPWS.24486024L	1.25"	24"	48"	60"	24"	104	\$818
FTENCPWS.24486024R	1.25"	24"	48"	60"	24"	104	\$818
FTENCPWS.24486624L	1.25"	24"	48"	66"	24"	110	\$921
FTENCPWS.24486624R	1.25"	24"	48"	66"	24"	110	\$921
FTENCPWS.24487224L	1.25"	24"	48"	72"	24"	116	\$934
FTENCPWS.24487224R	1.25"	24"	48"	72"	24"	116	\$934
FTENCPWS.24487824L	1.25"	24"	48"	78"	24"	121	\$1,155
FTENCPWS.24487824R	1.25"	24"	48"	78"	24"	121	\$1,155
FTENCPWS.24488424L	1.25"	24"	48"	84"	24"	127	\$1,159
FTENCPWS.24488424R	1.25"	24"	48"	84"	24"	127	\$1,159

24"D CONNECTING SIDE  
30"D EXTENSION  
36"D

PART #	HEIGHT	A	B	C	D	WT. (LBS)	PRICE
FTENCPWS.24366030L	1.25"	24"	36"	60"	30"	94	\$695
FTENCPWS.24366030R	1.25"	24"	36"	60"	30"	94	\$695
FTENCPWS.24366630L	1.25"	24"	36"	66"	30"	102	\$776
FTENCPWS.24366630R	1.25"	24"	36"	66"	30"	102	\$776
FTENCPWS.24367230L	1.25"	24"	36"	72"	30"	109	\$788
FTENCPWS.24367230R	1.25"	24"	36"	72"	30"	109	\$788
FTENCPWS.24367830L	1.25"	24"	36"	78"	30"	116	\$940
FTENCPWS.24367830R	1.25"	24"	36"	78"	30"	116	\$940
FTENCPWS.24368430L	1.25"	24"	36"	84"	30"	123	\$955
FTENCPWS.24368430R	1.25"	24"	36"	84"	30"	123	\$955

24"D CONNECTING SIDE  
30"D EXTENSION  
42"D

PART #	HEIGHT	A	B	C	D	WT. (LBS)	PRICE
FTENCPWS.24426030L	1.25"	24"	42"	60"	30"	102	\$814
FTENCPWS.24426030R	1.25"	24"	42"	60"	30"	102	\$814
FTENCPWS.24426630L	1.25"	24"	42"	66"	30"	110	\$918
FTENCPWS.24426630R	1.25"	24"	42"	66"	30"	110	\$918
FTENCPWS.24427230L	1.25"	24"	42"	72"	30"	117	\$932
FTENCPWS.24427230R	1.25"	24"	42"	72"	30"	117	\$932
FTENCPWS.24427830L	1.25"	24"	42"	78"	30"	124	\$1,152
FTENCPWS.24427830R	1.25"	24"	42"	78"	30"	124	\$1,152
FTENCPWS.24428430L	1.25"	24"	42"	84"	30"	131	\$1,157
FTENCPWS.24428430R	1.25"	24"	42"	84"	30"	131	\$1,157



**24"D CONNECTING SIDE  
30"D EXTENSION  
48"D**

PART #	HEIGHT	A	B	C	D	WT. (LBS)	PRICE
FTENCPWS.24486030L	1.25"	24"	48"	60"	30"	111	\$818
FTENCPWS.24486030R	1.25"	24"	48"	60"	30"	111	\$818
FTENCPWS.24486630L	1.25"	24"	48"	66"	30"	119	\$921
FTENCPWS.24486630R	1.25"	24"	48"	66"	30"	119	\$921
FTENCPWS.24487230L	1.25"	24"	48"	72"	30"	126	\$934
FTENCPWS.24487230R	1.25"	24"	48"	72"	30"	126	\$934
FTENCPWS.24487830L	1.25"	24"	48"	78"	30"	133	\$1,155
FTENCPWS.24487830R	1.25"	24"	48"	78"	30"	133	\$1,155
FTENCPWS.24488430L	1.25"	24"	48"	84"	30"	140	\$1,159
FTENCPWS.24488430R	1.25"	24"	48"	84"	30"	140	\$1,159

**30"D CONNECTING SIDE  
30"D EXTENSION  
36"D**

PART #	HEIGHT	A	B	C	D	WT. (LBS)	PRICE
FTENCPWS.30366030L	1.25"	30"	36"	60"	30"	95	\$735
FTENCPWS.30366030R	1.25"	30"	36"	60"	30"	95	\$735
FTENCPWS.30366630L	1.25"	30"	36"	66"	30"	103	\$816
FTENCPWS.30366630R	1.25"	30"	36"	66"	30"	103	\$816
FTENCPWS.30367230L	1.25"	30"	36"	72"	30"	110	\$828
FTENCPWS.30367230R	1.25"	30"	36"	72"	30"	110	\$828
FTENCPWS.30367830L	1.25"	30"	36"	78"	30"	118	\$980
FTENCPWS.30367830R	1.25"	30"	36"	78"	30"	118	\$980
FTENCPWS.30368430L	1.25"	30"	36"	84"	30"	125	\$994
FTENCPWS.30368430R	1.25"	30"	36"	84"	30"	125	\$994

**30"D CONNECTING SIDE  
30"D EXTENSION  
42"D**

PART #	HEIGHT	A	B	C	D	WT. (LBS)	PRICE
FTENCPWS.30426030L	1.25"	30"	42"	60"	30"	106	\$854
FTENCPWS.30426030R	1.25"	30"	42"	60"	30"	106	\$854
FTENCPWS.30426630L	1.25"	30"	42"	66"	30"	114	\$958
FTENCPWS.30426630R	1.25"	30"	42"	66"	30"	114	\$958
FTENCPWS.30427230L	1.25"	30"	42"	72"	30"	121	\$970
FTENCPWS.30427230R	1.25"	30"	42"	72"	30"	121	\$970
FTENCPWS.30427830L	1.25"	30"	42"	78"	30"	128	\$1,168
FTENCPWS.30427830R	1.25"	30"	42"	78"	30"	128	\$1,168
FTENCPWS.30428430L	1.25"	30"	42"	84"	30"	135	\$1,183
FTENCPWS.30428430R	1.25"	30"	42"	84"	30"	135	\$1,183

**90° Extended Notched Corner Peninsula Worksurface** continued

**30"D CONNECTING SIDE**  
**30"D EXTENSION**  
**48"D**

PART #	HEIGHT	A	B	C	D	WT. (LBS)	PRICE
FTENCPWS.30486030L	1.25"	30"	48"	60"	30"	116	\$857
FTENCPWS.30486030R	1.25"	30"	48"	60"	30"	116	\$857
FTENCPWS.30486630L	1.25"	30"	48"	66"	30"	124	\$961
FTENCPWS.30486630R	1.25"	30"	48"	66"	30"	124	\$961
FTENCPWS.30487230L	1.25"	30"	48"	72"	30"	131	\$973
FTENCPWS.30487230R	1.25"	30"	48"	72"	30"	131	\$973
FTENCPWS.30487830L	1.25"	30"	48"	78"	30"	138	\$1,172
FTENCPWS.30487830R	1.25"	30"	48"	78"	30"	138	\$1,172
FTENCPWS.30488430L	1.25"	30"	48"	84"	30"	144	\$1,186
FTENCPWS.30488430R	1.25"	30"	48"	84"	30"	144	\$1,186

## Extended Curved Corner Peninsula Worksurface

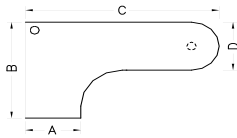
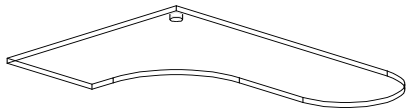

right extended shown

### DESCRIPTION

Worksurface hangs from a frame or wall strips. It has a laminate top and a PVC edge. There is a 1" gap at the back of the worksurface for plug and cord passage.

### NOTES

- Includes one support column leg, one wire grommet, cantilever brackets, one corner bracket and attachment hardware.
- Specify L for Left Extended and R for Right Extended.
- Column leg finish: DT Dark Tone only.

### SPECIFICATION OPTIONS

**product #:** see charts below  
**top edge finish:** see edge finishes, page 4  
**support finish:** LG Light Gray, BU Black Umber  
**laminate finish:** see laminates, page 4  
**left or right extended:** L left, R right

### ORDER EXAMPLE

**product #:** TECCPWS.24366024L  
**top edge finish:** LG Light Gray  
**support finish:** LG Light Gray  
**laminate finish:** Light Maple  
**left or right extended:** L left

### 24"D CONNECTING SIDE 24"D EXTENSION 36"D

PART #	HEIGHT	A	B	C	D	WT. (LBS)	PRICE
FTECCPWS.24366024L	1.25"	24"	36"	60"	24"	87	\$695
FTECCPWS.24366024R	1.25"	24"	36"	60"	24"	87	\$695
FTECCPWS.24366624L	1.25"	24"	36"	66"	24"	93	\$776
FTECCPWS.24366624R	1.25"	24"	36"	66"	24"	93	\$776
FTECCPWS.24367224L	1.25"	24"	36"	72"	24"	99	\$788
FTECCPWS.24367224R	1.25"	24"	36"	72"	24"	99	\$788
FTECCPWS.24367824L	1.25"	24"	36"	78"	24"	105	\$940
FTECCPWS.24367824R	1.25"	24"	36"	78"	24"	105	\$940
FTECCPWS.24368424L	1.25"	24"	36"	84"	24"	110	\$955
FTECCPWS.24368424R	1.25"	24"	36"	84"	24"	110	\$955

### 24"D CONNECTING SIDE 24"D EXTENSION 42"D

PART #	HEIGHT	A	B	C	D	WT. (LBS)	PRICE
FTECCPWS.24426024L	1.25"	24"	42"	60"	24"	94	\$814
FTECCPWS.24426024R	1.25"	24"	42"	60"	24"	94	\$814
FTECCPWS.24426624L	1.25"	24"	42"	66"	24"	100	\$918
FTECCPWS.24426624R	1.25"	24"	42"	66"	24"	100	\$918
FTECCPWS.24427224L	1.25"	24"	42"	72"	24"	106	\$930
FTECCPWS.24427224R	1.25"	24"	42"	72"	24"	106	\$930
FTECCPWS.24427824L	1.25"	24"	42"	78"	24"	111	\$1,152
FTECCPWS.24427824R	1.25"	24"	42"	78"	24"	111	\$1,152
FTECCPWS.24428424L	1.25"	24"	42"	84"	24"	116	\$1,155
FTECCPWS.24428424R	1.25"	24"	42"	84"	24"	116	\$1,155

## Extended Curved Corner Peninsula Worksurface continued

24"D CONNECTING SIDE  
24"D EXTENSION  
48"D

PART #	HEIGHT	A	B	C	D	WT. (LBS)	PRICE
FTECCPWS.24486024L	1.25"	24"	48"	60"	24"	101	\$818
FTECCPWS.24486024R	1.25"	24"	48"	60"	24"	101	\$818
FTECCPWS.24486624L	1.25"	24"	48"	66"	24"	107	\$921
FTECCPWS.24486624R	1.25"	24"	48"	66"	24"	107	\$921
FTECCPWS.24487224L	1.25"	24"	48"	72"	24"	112	\$934
FTECCPWS.24487224R	1.25"	24"	48"	72"	24"	112	\$934
FTECCPWS.24487824L	1.25"	24"	48"	78"	24"	118	\$1,155
FTECCPWS.24487824R	1.25"	24"	48"	78"	24"	118	\$1,155
FTECCPWS.24488424L	1.25"	24"	48"	84"	24"	124	\$1,159
FTECCPWS.24488424R	1.25"	24"	48"	84"	24"	124	\$1,159

24"D CONNECTING SIDE  
30"D EXTENSION  
36"D

PART #	HEIGHT	A	B	C	D	WT. (LBS)	PRICE
FTECCPWS.24366030L	1.25"	24"	36"	60"	30"	94	\$695
FTECCPWS.24366030R	1.25"	24"	36"	60"	30"	94	\$695
FTECCPWS.24366630L	1.25"	24"	36"	66"	30"	101	\$776
FTECCPWS.24366630R	1.25"	24"	36"	66"	30"	101	\$776
FTECCPWS.24367230L	1.25"	24"	36"	72"	30"	108	\$788
FTECCPWS.24367230R	1.25"	24"	36"	72"	30"	108	\$788
FTECCPWS.24367830L	1.25"	24"	36"	78"	30"	115	\$940
FTECCPWS.24367830R	1.25"	24"	36"	78"	30"	115	\$940
FTECCPWS.24368430L	1.25"	24"	36"	84"	30"	123	\$955
FTECCPWS.24368430R	1.25"	24"	36"	84"	30"	123	\$955

24"D CONNECTING SIDE  
30"D EXTENSION  
42"D

PART #	HEIGHT	A	B	C	D	WT. (LBS)	PRICE
FTECCPWS.24426030L	1.25"	24"	42"	60"	30"	100	\$814
FTECCPWS.24426030R	1.25"	24"	42"	60"	30"	100	\$814
FTECCPWS.24426630L	1.25"	24"	42"	66"	30"	107	\$918
FTECCPWS.24426630R	1.25"	24"	42"	66"	30"	107	\$918
FTECCPWS.24427230L	1.25"	24"	42"	72"	30"	113	\$932
FTECCPWS.24427230R	1.25"	24"	42"	72"	30"	113	\$932
FTECCPWS.24427830L	1.25"	24"	42"	78"	30"	120	\$1,152
FTECCPWS.24427830R	1.25"	24"	42"	78"	30"	120	\$1,152
FTECCPWS.24428430L	1.25"	24"	42"	84"	30"	126	\$1,157
FTECCPWS.24428430R	1.25"	24"	42"	84"	30"	126	\$1,157

**24"D CONNECTING SIDE  
30"D EXTENSION  
48"D**

PART #	HEIGHT	A	B	C	D	WT. (LBS)	PRICE
FTECCPWS.24486030L	1.25"	24"	48"	60"	30"	107	\$818
FTECCPWS.24486030R	1.25"	24"	48"	60"	30"	107	\$818
FTECCPWS.24486630L	1.25"	24"	48"	66"	30"	113	\$921
FTECCPWS.24486630R	1.25"	24"	48"	66"	30"	113	\$921
FTECCPWS.24487230L	1.25"	24"	48"	72"	30"	118	\$934
FTECCPWS.24487230R	1.25"	24"	48"	72"	30"	118	\$934
FTECCPWS.24487830L	1.25"	24"	48"	78"	30"	124	\$1,155
FTECCPWS.24487830R	1.25"	24"	48"	78"	30"	124	\$1,155
FTECCPWS.24488430L	1.25"	24"	48"	84"	30"	129	\$1,159
FTECCPWS.24488430R	1.25"	24"	48"	84"	30"	129	\$1,159

**30"D CONNECTING SIDE  
30"D EXTENSION  
36"D**

PART #	HEIGHT	A	B	C	D	WT. (LBS)	PRICE
FTECCPWS.30366030L	1.25"	30"	36"	60"	30"	95	\$735
FTECCPWS.30366030R	1.25"	30"	36"	60"	30"	95	\$735
FTECCPWS.30366630L	1.25"	30"	36"	66"	30"	103	\$816
FTECCPWS.30366630R	1.25"	30"	36"	66"	30"	103	\$816
FTECCPWS.30367230L	1.25"	30"	36"	72"	30"	110	\$828
FTECCPWS.30367230R	1.25"	30"	36"	72"	30"	110	\$828
FTECCPWS.30367830L	1.25"	30"	36"	78"	30"	117	\$980
FTECCPWS.30367830R	1.25"	30"	36"	78"	30"	117	\$980
FTECCPWS.30368430L	1.25"	30"	36"	84"	30"	124	\$994
FTECCPWS.30368430R	1.25"	30"	36"	84"	30"	124	\$994

**30"D CONNECTING SIDE  
30"D EXTENSION  
42"D**

PART #	HEIGHT	A	B	C	D	WT. (LBS)	PRICE
FTECCPWS.30426030L	1.25"	30"	42"	60"	30"	101	\$854
FTECCPWS.30426030R	1.25"	30"	42"	60"	30"	101	\$854
FTECCPWS.30426630L	1.25"	30"	42"	66"	30"	108	\$958
FTECCPWS.30426630R	1.25"	30"	42"	66"	30"	108	\$958
FTECCPWS.30427230L	1.25"	30"	42"	72"	30"	114	\$970
FTECCPWS.30427230R	1.25"	30"	42"	72"	30"	114	\$970
FTECCPWS.30427830L	1.25"	30"	42"	78"	30"	120	\$1,168
FTECCPWS.30427830R	1.25"	30"	42"	78"	30"	120	\$1,168
FTECCPWS.30428430L	1.25"	30"	42"	84"	30"	127	\$1,183
FTECCPWS.30428430R	1.25"	30"	42"	84"	30"	127	\$1,183

**Extended Curved Corner Peninsula Worksurface** continued

**30"D CONNECTING SIDE**  
**30"D EXTENSION**  
**48"D**

PART #	HEIGHT	A	B	C	D	WT. (LBS)	PRICE
FTECCPWS.30486030L	1.25"	30"	48"	60"	30"	107	\$857
FTECCPWS.30486030R	1.25"	30"	48"	60"	30"	107	\$857
FTECCPWS.30486630L	1.25"	30"	48"	66"	30"	113	\$961
FTECCPWS.30486630R	1.25"	30"	48"	66"	30"	113	\$961
FTECCPWS.30487230L	1.25"	30"	48"	72"	30"	118	\$973
FTECCPWS.30487230R	1.25"	30"	48"	72"	30"	118	\$973
FTECCPWS.30487830L	1.25"	30"	48"	78"	30"	124	\$1,172
FTECCPWS.30487830R	1.25"	30"	48"	78"	30"	124	\$1,172
FTECCPWS.30488430L	1.25"	30"	48"	84"	30"	129	\$1,186
FTECCPWS.30488430R	1.25"	30"	48"	84"	30"	129	\$1,186

## Extended Curved Corner P-Shape Peninsula Worksurface

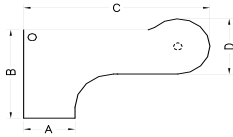
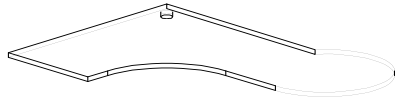

right extended shown

### DESCRIPTION

Worksurface hangs from a frame or wall strips. It has a laminate top and a PVC edge. There is a 1" gap at the back of the worksurface for plug and cord passage.

### NOTES

- Includes one support column leg, one wire grommet, cantilever brackets, one corner bracket and attachment hardware.
- Specify L for Left Extended and R for Right Extended.
- Column leg finish: DT Dark Tone only.

### SPECIFICATION OPTIONS

**product #:** see charts below  
**top edge finish:** see edge finishes, page 4  
**support finish:** LG Light Gray, BU Black Umber  
**laminate finish:** see laminates, page 4  
**left or right extended:** L left, R right

### ORDER EXAMPLE

**product #:** FTECCPPWS.24426024L  
**top edge finish:** LG Light Gray  
**support finish:** LG Light Gray  
**laminate finish:** Light Maple  
**left or right extended:** L left

### 24"D CONNECTING SIDES 42"D

PART #	HEIGHT	A	B	C	D	WT. (LBS)	PRICE
FTECCPPWS.24426024L	1.25"	24"	42"	60"	36"	105	\$864
FTECCPPWS.24426024R	1.25"	24"	42"	60"	36"	105	\$864
FTECCPPWS.24426624L	1.25"	24"	42"	66"	36"	112	\$971
FTECCPPWS.24426624R	1.25"	24"	42"	66"	36"	112	\$971
FTECCPPWS.24427224L	1.25"	24"	42"	72"	36"	119	\$987
FTECCPPWS.24427224R	1.25"	24"	42"	72"	36"	119	\$987
FTECCPPWS.24427824L	1.25"	24"	42"	78"	36"	126	\$1,189
FTECCPPWS.24427824R	1.25"	24"	42"	78"	36"	126	\$1,189
FTECCPPWS.24428424L	1.25"	24"	42"	84"	36"	134	\$1,209
FTECCPPWS.24428424R	1.25"	24"	42"	84"	36"	134	\$1,209

### 24"D CONNECTING SIDES 48"D

PART #	HEIGHT	A	B	C	D	WT. (LBS)	PRICE
FTECCPPWS.24486024L	1.25"	24"	48"	60"	36"	113	\$983
FTECCPPWS.24486024R	1.25"	24"	48"	60"	36"	113	\$983
FTECCPPWS.24486624L	1.25"	24"	48"	66"	36"	120	\$1,113
FTECCPPWS.24486624R	1.25"	24"	48"	66"	36"	120	\$1,113
FTECCPPWS.24487224L	1.25"	24"	48"	72"	36"	127	\$1,129
FTECCPPWS.24487224R	1.25"	24"	48"	72"	36"	127	\$1,129
FTECCPPWS.24487824L	1.25"	24"	48"	78"	36"	134	\$1,378
FTECCPPWS.24487824R	1.25"	24"	48"	78"	36"	134	\$1,378
FTECCPPWS.24488424L	1.25"	24"	48"	84"	36"	141	\$1,397
FTECCPPWS.24488424R	1.25"	24"	48"	84"	36"	141	\$1,397

## Extended Curved Corner P-Shape Peninsula Worksurface continued

30"D CONNECTING SIDE  
42"D

PART #	HEIGHT	A	B	C	D	WT. (LBS)	PRICE
FTECCPPWS.30426030L	1.25"	30"	42"	60"	36"	109	\$903
FTECCPPWS.30426030R	1.25"	30"	42"	60"	36"	109	\$903
FTECCPPWS.30426630L	1.25"	30"	42"	66"	36"	116	\$1,010
FTECCPPWS.30426630R	1.25"	30"	42"	66"	36"	116	\$1,010
FTECCPPWS.30427230L	1.25"	30"	42"	72"	36"	123	\$1,026
FTECCPPWS.30427230R	1.25"	30"	42"	72"	36"	123	\$1,026
FTECCPPWS.30427830L	1.25"	30"	42"	78"	36"	131	\$1,229
FTECCPPWS.30427830R	1.25"	30"	42"	78"	36"	131	\$1,229
FTECCPPWS.30428430L	1.25"	30"	42"	84"	36"	138	\$1,249
FTECCPPWS.30428430R	1.25"	30"	42"	84"	36"	138	\$1,249

30"D CONNECTING SIDE  
48"D

PART #	HEIGHT	A	B	C	D	WT. (LBS)	PRICE
FTECCPPWS.30486030L	1.25"	30"	48"	60"	36"	116	\$1,022
FTECCPPWS.30486030R	1.25"	30"	48"	60"	36"	116	\$1,022
FTECCPPWS.30486630L	1.25"	30"	48"	66"	36"	123	\$1,152
FTECCPPWS.30486630R	1.25"	30"	48"	66"	36"	123	\$1,152
FTECCPPWS.30487230L	1.25"	30"	48"	72"	36"	132	\$1,168
FTECCPPWS.30487230R	1.25"	30"	48"	72"	36"	132	\$1,168
FTECCPPWS.30487830L	1.25"	30"	48"	78"	36"	139	\$1,417
FTECCPPWS.30487830R	1.25"	30"	48"	78"	36"	139	\$1,417
FTECCPPWS.30488430L	1.25"	30"	48"	84"	36"	146	\$1,437
FTECCPPWS.30488430R	1.25"	30"	48"	84"	36"	146	\$1,437



# Ellipse End Peninsula Worksurface

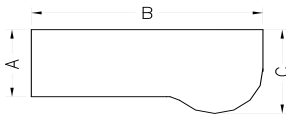
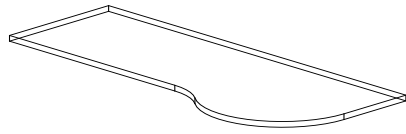

DESCRIPTION

Worksurface hangs from a frame or wall strips. It has a laminate top and a PVC edge. There is a 1" gap at the back of the worksurface for plug and cord passage.

SPECIFICATION OPTIONS

**product #:** see charts below  
**top edge finish:** see edge finishes, page 4  
**support finish:** LG Light Gray, BU Black Umber  
**laminate finish:** see laminates, page 4

NOTES

- 60" to 84" worksurfaces have a center support.
- Includes cantilever brackets and attachment hardware.

ORDER EXAMPLE

**product #:** FTEEPWS.246030  
**top edge finish:** LG Light Gray  
**support finish:** LG Light Gray  
**laminate finish:** Light Maple

24"D LEFT  
30"D RIGHT

PART #	HEIGHT	A	B	C	D	WT. (LBS)	PRICE
FTEEPWS.246030	1.25"	24"	60"	30"	—	52	\$559
FTEEPWS.246630	1.25"	24"	66"	30"	—	59	\$627
FTEEPWS.247230	1.25"	24"	72"	30"	—	66	\$638
FTEEPWS.247830	1.25"	24"	78"	30"	—	74	\$766
FTEEPWS.248430	1.25"	24"	84"	30"	—	81	\$779

30"D LEFT  
24"D RIGHT

PART #	HEIGHT	A	B	C	D	WT. (LBS)	PRICE
FTEEPWS.306024	1.25"	30"	60"	24"	—	52	\$559
FTEEPWS.306624	1.25"	30"	66"	24"	—	59	\$627
FTEEPWS.307224	1.25"	30"	72"	24"	—	66	\$638
FTEEPWS.307824	1.25"	30"	78"	24"	—	74	\$766
FTEEPWS.308424	1.25"	30"	84"	24"	—	81	\$779

36"D LEFT  
30"D RIGHT

PART #	HEIGHT	A	B	C	D	WT. (LBS)	PRICE
FTEEPWS.306036	1.25"	30"	60"	36"	—	57	\$656
FTEEPWS.306636	1.25"	30"	66"	36"	—	64	\$736
FTEEPWS.307236	1.25"	30"	72"	36"	—	71	\$747
FTEEPWS.307836	1.25"	30"	78"	36"	—	79	\$898
FTEEPWS.308436	1.25"	30"	84"	36"	—	86	\$912

36"D LEFT  
30"D RIGHT

PART #	HEIGHT	A	B	C	D	WT. (LBS)	PRICE
FTEEPWS.366030	1.25"	36"	60"	30"	—	57	\$656
FTEEPWS.366630	1.25"	36"	66"	30"	—	64	\$736
FTEEPWS.367230	1.25"	36"	72"	30"	—	71	\$747
FTEEPWS.367830	1.25"	36"	78"	30"	—	79	\$898
FTEEPWS.368430	1.25"	36"	84"	30"	—	86	\$912

## Rectangular Asymmetrical Worksurface

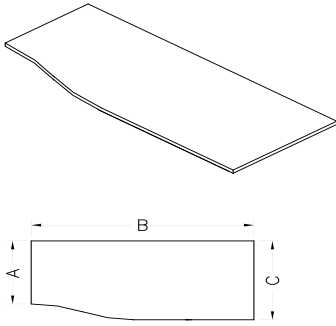

### DESCRIPTION

Worksurface hangs from a frame or wall strips. It has a laminate top and a PVC edge. There is a 1" gap at the back of the worksurface for plug and cord passage.

### NOTES

- 60" to 84" worksurfaces have a center support.
- 78" and 84" worksurfaces will accept a 42"W or 36"W lateral file.
- 72"W worksurface will accept a 36"W lateral file.
- 66"W worksurface will accept a 30"W lateral file.
- Worksurfaces shorter than 48"W will not accept a pedestal.
- Includes cantilever brackets, one corner bracket, and attachment hardware.

### SPECIFICATION OPTIONS

**product #:** see charts below  
**top edge finish:** see edge finishes, page 4  
**support finish:** LG Light Gray, BU Black Umber  
 laminate finish: see laminates, page 4

### ORDER EXAMPLE

**product #:** FTRWWS.243030  
**top edge finish:** LG Light Gray  
**support finish:** LG Light Gray  
**laminate finish:** Light Maple

### 24"D LEFT 30"D RIGHT

PART #	HEIGHT	A	B	C	D	WT. (LBS)	PRICE
FTRWWS.243030	1.25"	24"	30"	30"	—	40	\$278
FTRWWS.243630	1.25"	24"	36"	30"	—	46	\$325
FTRWWS.244230	1.25"	24"	42"	30"	—	53	\$330
FTRWWS.244830	1.25"	24"	48"	30"	—	60	\$409
FTRWWS.245430	1.25"	24"	54"	30"	—	66	\$414
FTRWWS.246030	1.25"	24"	60"	30"	—	74	\$495
FTRWWS.246630	1.25"	24"	66"	30"	—	81	\$500
FTRWWS.247230	1.25"	24"	72"	30"	—	88	\$564
FTRWWS.247830	1.25"	24"	78"	30"	—	95	\$570
FTRWWS.248430	1.25"	24"	84"	30"	—	102	\$691

### 30"D LEFT 24"D RIGHT

PART #	HEIGHT	A	B	C	D	WT. (LBS)	PRICE
FTRWWS.303024	1.25"	30"	30"	24"	—	40	\$278
FTRWWS.303624	1.25"	30"	36"	24"	—	46	\$325
FTRWWS.304224	1.25"	30"	42"	24"	—	53	\$330
FTRWWS.304824	1.25"	30"	48"	24"	—	60	\$409
FTRWWS.305424	1.25"	30"	54"	24"	—	66	\$414
FTRWWS.306024	1.25"	30"	60"	24"	—	74	\$495
FTRWWS.306624	1.25"	30"	66"	24"	—	81	\$500
FTRWWS.307224	1.25"	30"	72"	24"	—	88	\$564
FTRWWS.307824	1.25"	30"	78"	24"	—	95	\$570
FTRWWS.308424	1.25"	30"	84"	24"	—	102	\$691

# 120° Rectangular Worksurface

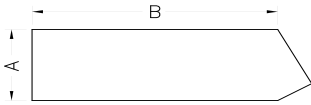
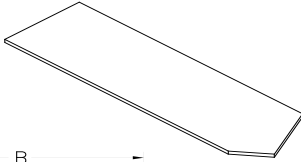
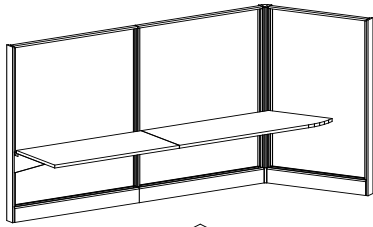

**DESCRIPTION**

Worksurface hangs from a frame and has a 120° End, either left or right. The end fits against a frame connected by a 120° connector. It has a laminate top and a PVC edge. There is a 1" gap at the back of the worksurface for plug and cord passage. Worksurface is 24" deep.

**NOTES**

- Includes cantilever brackets, one corner bracket, and attachment hardware.
- Specify L for left end angle and R for right end angle.

**SPECIFICATION OPTIONS**

**product #:** see charts below  
**top edge finish:** see edge finishes, page 4  
**support finish:** LG Light Gray, BU Black Umber  
**laminate finish:** see laminates, page 4  
**left or right angle:** L left angle, R right angle

**ORDER EXAMPLE**

**product #:** FT120WS.2424L  
**top edge finish:** LG Light Gray  
**support finish:** LG Light Gray  
**laminate finish:** Light Maple  
**left or right angle:** L left angle

**120° RECTANGULAR**

PART #	HEIGHT	A	B	C	D	WT. (LBS)	PRICE
FT120WS.2424L	1.25"	24"	24"	—	—	33	\$342
FT120WS.2424R	1.25"	24"	24"	—	—	33	\$342
FT120WS.2430L	1.25"	24"	30"	—	—	40	\$372
FT120WS.2430R	1.25"	24"	30"	—	—	40	\$372
FT120WS.2436L	1.25"	24"	36"	—	—	45	\$403
FT120WS.2436R	1.25"	24"	36"	—	—	45	\$403
FT120WS.2442L	1.25"	24"	42"	—	—	52	\$457
FT120WS.2442R	1.25"	24"	42"	—	—	52	\$457
FT120WS.2448L	1.25"	24"	48"	—	—	57	\$466
FT120WS.2448R	1.25"	24"	48"	—	—	57	\$466
FT120WS.2460L	1.25"	24"	60"	—	—	64	\$541
FT120WS.2460R	1.25"	24"	60"	—	—	64	\$541

## 120° Corner Worksurface 90° Ends

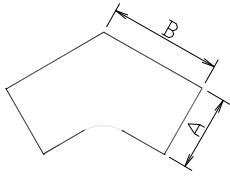
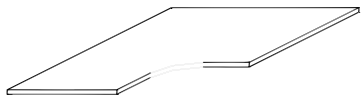
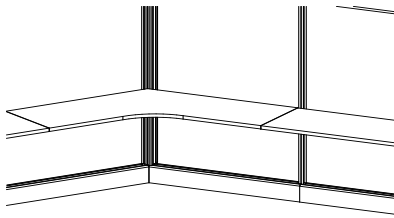

### 120° CORNER WORKSURFACE, 90° ENDS

#### DESCRIPTION

Worksurface hangs from a frame. It has a laminate top and a PVC edge. There is a 1" gap at the back of the worksurface for plug and cord passage. Worksurface is 24" deep.

#### NOTES

- Includes cantilever brackets, one corner bracket, and attachment hardware.

#### SPECIFICATION OPTIONS

**product #:** see charts below  
**top edge finish:** see edge finishes, page 4  
**support finish:** LG Light Gray, BU Black Umber  
**laminate finish:** see laminates, page 4

#### ORDER EXAMPLE

**product #:** FT120/90WS.2424  
**top edge finish:** LG Light Gray  
**support finish:** LG Light Gray  
**laminate finish:** Light Maple

PART #	HEIGHT	A	B	C	D	WT. (LBS)	PRICE
FT120/90WS.2424	1.25"	24"	24"	—	—	30	\$449
FT120/90WS.2430	1.25"	24"	30"	—	—	41	\$515
FT120/90WS.2436	1.25"	24"	36"	—	—	50	\$651
FT120/90WS.2442	1.25"	24"	42"	—	—	62	\$798
FT120/90WS.2448	1.25"	24"	48"	—	—	80	\$992

# 120° Corner Worksurface 120° Ends

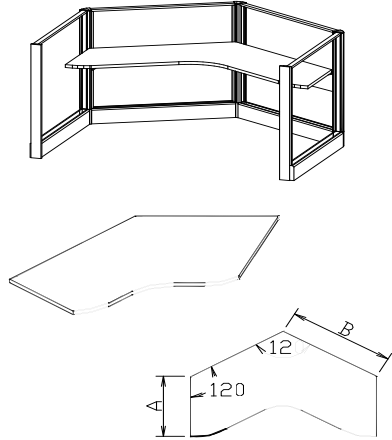

**DESCRIPTION**

Worksurface hangs from a frame. It has a laminate top and a PVC edge. There is a 1" gap at the back of the worksurface for plug and cord passage. Worksurface is 24" deep.

**NOTES**

- Includes cantilever brackets, one corner bracket, and attachment hardware.

**SPECIFICATION OPTIONS**

**product #:** see charts below  
**top edge finish:** see edge finishes, page 4  
**support finish:** LG Light Gray, BU Black Umber  
**laminate finish:** see laminates, page 4

**ORDER EXAMPLE**

**product #:** FT120/120WS.2436  
**top edge finish:** LG Light Gray  
**support finish:** LG Light Gray  
**laminate finish:** Light Maple

**120° CORNER WORKSURFACE, 120° ENDS**

PART #	HEIGHT	A	B	C	D	WT. (LBS)	PRICE
FT120/120WS.2436	1.25"	24"	36"	—	—	50	\$656
FT120/120WS.2442	1.25"	24"	42"	—	—	62	\$804
FT120/120WS.2448	1.25"	24"	48"	—	—	80	\$999

## 135° Corner Worksurface

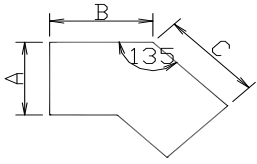
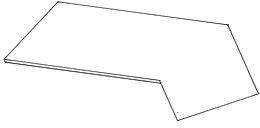
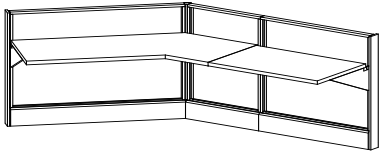

### DESCRIPTION

Worksurface hangs from 2 frames, connected by a 135° 2-Way connector. It has a laminate top and a PVC edge. There is a 1" gap at the back of the worksurface for plug and cord passage.

### NOTES

- The width of each side of the worksurface must match the width of the adjacent frames.
- Includes cantilever brackets, corner bracket and attachment hardware.

### SPECIFICATION OPTIONS

**product #:** see charts below  
**top edge finish:** see edge finishes, page 4  
**support finish:** LG Light Gray, BU Black Umber  
**laminate finish:** see laminates, page 4

### ORDER EXAMPLE

**product #:** FT135CWS24.2424  
**top edge finish:** LG Light Gray  
**support finish:** LG Light Gray  
**laminate finish:** Light Maple

### 24"D

PART #	HEIGHT	A	B	C	D	WT. (LBS)	PRICE
FT135CWS24.2424	1.25"	24"	24"	24"	—	50	\$588
FT135CWS24.3030	1.25"	24"	30"	30"	—	54	\$692
FT135CWS24.4824	1.25"	24"	48"	24"	—	70	\$658
FT135CWS24.2448	1.25"	24"	24"	48"	—	70	\$802

### 30"D

PART #	HEIGHT	A	B	C	D	WT. (LBS)	PRICE
FT135CWS30.2424	1.25"	30"	24"	24"	—	55	\$612
FT135CWS30.3030	1.25"	30"	30"	30"	—	59	\$718
FT135CWS30.4824	1.25"	30"	48"	24"	—	74	\$815
FT135CWS30.2448	1.25"	30"	24"	48"	—	74	\$821

# 135° Double Corner Worksurface

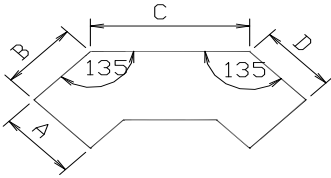
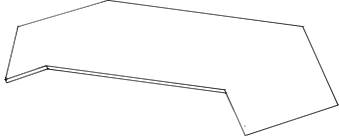
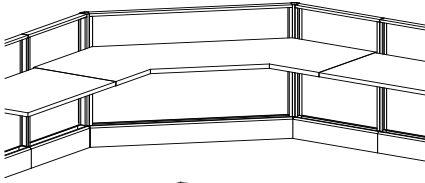

**DESCRIPTION**

Worksurface hangs from 3 frames, connected by two 135° 2-Way connectors. It has a laminate top and a PVC edge. There is a 1" gap at the back of the worksurface for plug and cord passage.

**NOTES**

- The width of each side of the worksurface must match the width of the adjacent frames.
- Includes cantilever brackets, corner bracket and attachment hardware.

**SPECIFICATION OPTIONS**

**product #:** see charts below  
**top edge finish:** see edge finishes, page 4  
**support finish:** LG Light Gray, BU Black Umber  
**laminate finish:** see laminates, page 4

**ORDER EXAMPLE**

**product #:** FT135DCWS24.244824  
**top edge finish:** LG Light Gray  
**support finish:** LG Light Gray  
**laminate finish:** Light Maple

**24"D**

PART #	HEIGHT	A	B	C	D	WT. (LBS)	PRICE
FT135DCWS24.244824	1.25"	24"	24"	48"	24"	80	\$1,116

**30"D**

PART #	HEIGHT	A	B	C	D	WT. (LBS)	PRICE
FT135DCWS30.244824	1.25"	30"	24"	48"	24"	84	\$1,120

## Rectangular Transaction Worksurface

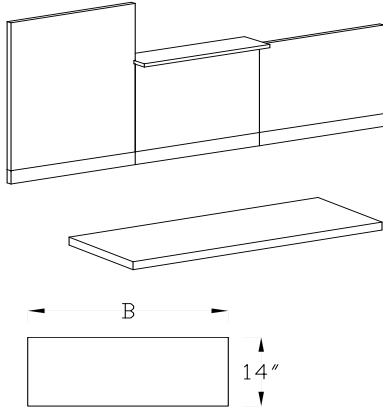

### DESCRIPTION

14"D Rectangular Transaction Worksurface attaches to the top of a Frame, without Top Cap. Ends are flush with the frame. It has a laminate top, and a PVC edge. Attachment hardware is included.

### NOTES

- Order without cutout or with cutout on 1 side.
- Cutout only to be used with Change of Height Condition.
- Attaches to top of a panel for counter or display area.

### SPECIFICATION OPTIONS

**product #:** see charts below  
**top edge finish:** see edge finishes, page 4  
**support finish:** LG Light Gray, BU Black Umber  
**laminate finish:** see laminates, page 4

### ORDER EXAMPLE

**product #:** FTRTS.1424N  
**top edge finish:** LG Light Gray  
**support finish:** LG Light Gray  
**laminate finish:** Light Maple

### WITHOUT CUTOUT

PART #	HEIGHT	A	B	C	D	WT. (LBS)	PRICE
FTRTS.1424N	1.25"	14"	24"	—	—	17	\$196
FTRTS.1430N	1.25"	14"	30"	—	—	21	\$222
FTRTS.1436N	1.25"	14"	36"	—	—	24	\$237
FTRTS.1442N	1.25"	14"	42"	—	—	27	\$279
FTRTS.1448N	1.25"	14"	48"	—	—	31	\$283

### WITH CUTOUT

PART #	HEIGHT	A	B	C	D	WT. (LBS)	PRICE
FTRTS.1424C	1.25"	14"	24"	—	—	17	\$224
FTRTS.1430C	1.25"	14"	30"	—	—	21	\$251
FTRTS.1436C	1.25"	14"	36"	—	—	24	\$266
FTRTS.1442C	1.25"	14"	42"	—	—	27	\$312
FTRTS.1448C	1.25"	14"	48"	—	—	31	\$316



# Corner Transaction Worksurface

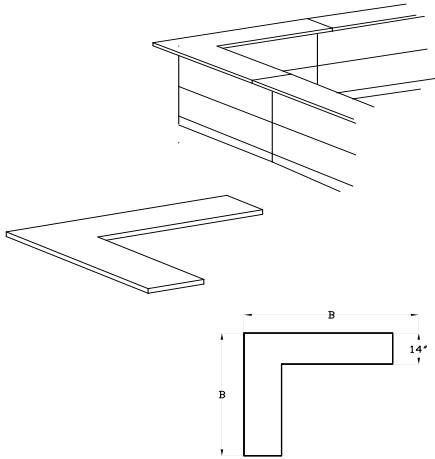

**DESCRIPTION**

14"D Corner Transaction Worksurface attaches to the top of two frames. Ends are flush with the panel. It has a laminate top and a PVC edge.

**NOTES**

- Attachment hardware is included.
- Attaches to the top of two 24", 30", 36", 42", or 48"W frames connected at a 90° angle for corner counter or display area.

**SPECIFICATION OPTIONS**

**product #:** see charts below  
**top edge finish:** see edge finishes, page 4  
**support finish:** LG Light Gray, BU Black Umber  
**laminate finish:** see laminates, page 4

**ORDER EXAMPLE**

**product #:** FTCTS.24  
**top edge finish:** LG Light Gray  
**support finish:** LG Light Gray  
**laminate finish:** Light Maple

**CORNER TRANSACTION WORKSURFACE**

PART #	HEIGHT	A	B	C	D	WT. (LBS)	PRICE
FTCTS.24	1.25"	14"	32"	—	—	40	\$407
FTCTS.30	1.25"	14"	38"	—	—	48	\$526
FTCTS.36	1.25"	14"	44"	—	—	55	\$576
FTCTS.42	1.25"	14"	50"	—	—	62	\$791
FTCTS.48	1.25"	14"	56"	—	—	71	\$795

## Racetrack Transaction Worksurface

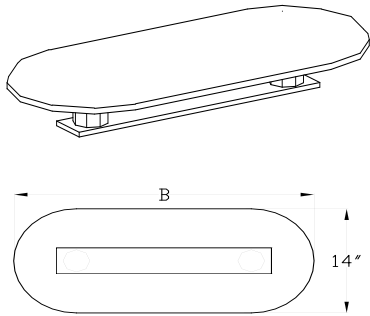

### DESCRIPTION

This Racetrack worksurface attaches to the top of a frame and provides a reception counter. It has a laminate top and a PVC edge.

### NOTES

- Attachment hardware included.
- Support base finish: BU Black Umber

### SPECIFICATION OPTIONS

product #: see charts below  
 top edge finish: see edge finishes, page 4  
 support finish: LG Light Gray, BU Black Umber  
 laminate finish: see laminates, page 4

### ORDER EXAMPLE

product #: FTRTWS.1434  
 top edge finish: LG Light Gray  
 support finish: LG Light Gray  
 laminate finish: Light Maple

### WITHOUT CUTOUT

PART #	HEIGHT	A	B	C	D	WT. (LBS)	PRICE
FTRTWS.1434	4.25"	14"	34"	—	—	26	\$529
FTRTWS.1440	4.25"	14"	40"	—	—	29	\$619

## Custom Transaction Worksurface Support

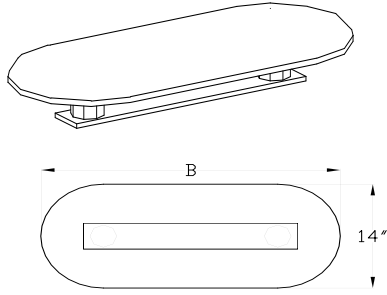

**DESCRIPTION**

Specify this support when using your own granite, marble, or solid surface base plate support is provided.

**NOTES**

- Attachment hardware included.

**SPECIFICATION OPTIONS**

**product #:** see charts below  
**support finish:** LG Light Gray, BU Black Umber

**ORDER EXAMPLE**

**product #:** FTCTWS.34  
**support finish:** BU Black Umber

**CUSTOM TRANSACTION WORKSURFACE SUPPORT**

PART #	HEIGHT	A	B	C	D	WT. (LBS)	PRICE	DESCRIPTION & NOTES
FTCTWS.34	3.25"	14" *	34" *	—	—	10	\$302	* Outside dimensions of granite, marble or solid surface.
FTCTWS.40	3.25"	14" *	40" *	—	—	12	\$350	

# Flat Bracket

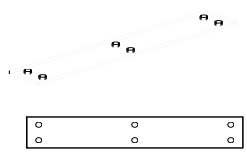

### DESCRIPTION

This Flat Bracket is used to support two worksurfaces when a support leg or panel leg is inappropriate.

### NOTES

- **Finish: Black**

### SPECIFICATION OPTIONS

**product #:** see charts below

### ORDER EXAMPLE

**product #:** FTFB.18

## FLAT BRACKET

PART #	HEIGHT	A	B	C	D	WT. (LBS)	PRICE
FTFB.18	—	3"	18"	—	—	1	\$30

# Supports

<p>DESCRIPTION</p> <hr/> <p>NOTES</p> <hr/>	<p>SPECIFICATION OPTIONS</p> <hr/> <p><b>product #:</b> see charts below  <b>edge finish:</b> see edge finishes, page 4  <b>support finish:</b> see laminates, page 4</p> <hr/> <p>ORDER EXAMPLE</p> <hr/> <p><b>product #:</b> FTWSSEP.24-LAM  <b>edge finish:</b> LG Light Gray  <b>support finish:</b> LG Light Gray</p>
---	---

## WORKSURFACE SUPPORT END PANEL

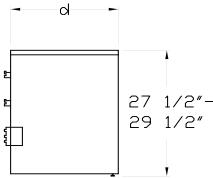
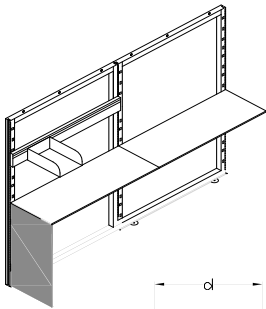

PART #	HEIGHT	WIDTH	DEPTH	WT. (LBS)	PRICE
FTWSSEP.24-LAM	27.75"	1.25"	24"	26	\$306
FTWSSEP.30-LAM	27.75"	1.25"	30"	32	\$350

**DESCRIPTION & NOTES**

---

**DESCRIPTION:**  
 Non-handed laminate panel with 3MM PVC edge. Supports left or right side of a work surface. Attaches to frame and work surface.

Includes leveling glides.  
 Includes attachment hardware.

**NOTES:**

- Specify laminate and PVC edge finishes.

## WORKSURFACE SUPPORT HALF LEG

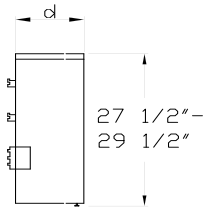
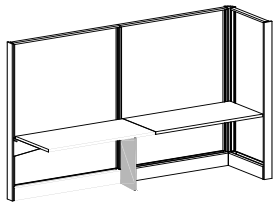

PART #	HEIGHT	WIDTH	DEPTH	WT. (LBS)	PRICE
FTWSSHL.12-LAM	27.75"	1.25"	12"	13	\$194
FTWSSHL.15-LAM	27.75"	1.25"	15"	16	\$217

**DESCRIPTION & NOTES**

---

**DESCRIPTION:**  
 Non-handed laminate panel with 3MM PVC edge. Supports left or right side of a work surface. Attaches to frame and work surface.

Includes leveling glides.  
 Includes attachment hardware.

**NOTES:**

- Specify laminate and PVC edge finishes.

## Supports continued

### WORKSURFACE BRACKET

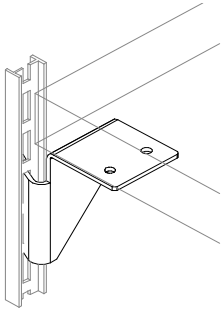

PART #	HEIGHT	WIDTH	DEPTH	WT. (LBS)	PRICE
FTWSB.L	2.75"	—	2.5"	0.25	\$12
FTWSB.R	2.75"	—	2.5"	0.25	\$12

#### DESCRIPTION & NOTES

**DESCRIPTION:**  
Attaches to the front of a hanging worksurface to provide additional support when the return frame matches the depth of the worksurface.

Also used as support for the back corner of a corner worksurface.

#### NOTES:

- Specify left or right.
- Color: Black.

### OPEN METAL WORKSURFACE SUPPORT

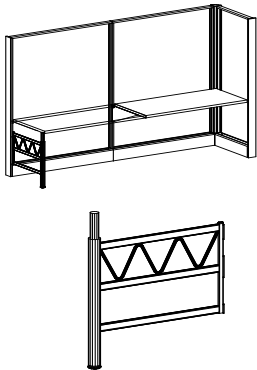

PART #	HEIGHT	WIDTH	DEPTH	WT. (LBS)	PRICE
FTOMWS.2724	—	—	24"	17	\$197
FTOMWS.2730	—	—	30"	19	\$217

#### DESCRIPTION & NOTES

**DESCRIPTION:**  
This support attaches to a worksurface, and a frame or wall strip. It provides support and eliminates the need for a return frame. The open support is adjustable from 27-1/2" to 31-1/2"H.

#### NOTES:

- To convert from left handed to right handed, remove attachment brackets, and reinstall in the position needed.
- Specify the depth of the worksurface support to match the depth of the worksurface.

# Overheads & Shelves

DESCRIPTION

SPECIFICATION OPTIONS

NOTES

**product #:** see charts below  
**finish:** see laminates, page 4  
**fabric:** see fabrics, page 4

ORDER EXAMPLE

**product #:** FTFFLU1324L  
**finish:** LG Light Gray  
**fabric:** PF601-5, Passage-Leaf

## "B" STYLE SHELF HALF HEIGHT

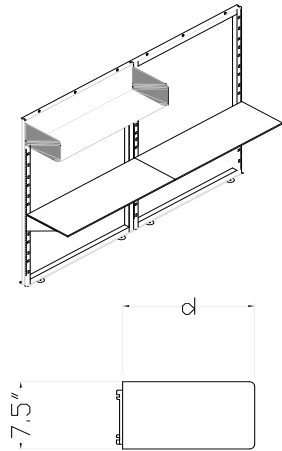

PART #	HEIGHT	WIDTH	DEPTH	WT. (LBS)	PRICE
FTHSH.0824	7.5"	24"	12.75"	12	\$127
FTHSH.0830	7.5"	30"	12.75"	13	\$135
FTHSH.0836	7.5"	36"	12.75"	13	\$145
FTHSH.0842	7.5"	42"	12.75"	14	\$156
FTHSH.0848	7.5"	48"	12.75"	15	\$164

**DESCRIPTION & NOTES**

**DESCRIPTION:**  
 This shelf hangs from a frame or wall strips.

Includes attachment hardware.

## "B" STYLE SHELF FULL HEIGHT

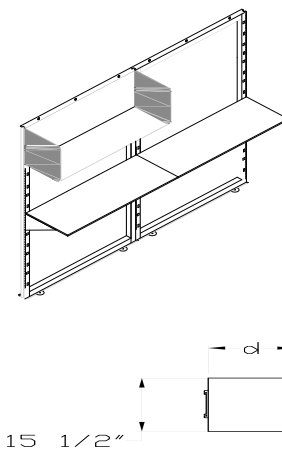

PART #	HEIGHT	WIDTH	DEPTH	WT. (LBS)	PRICE
FTFSH.1324	15.5"	24"	12.75"	16	\$152
FTFSH.1330	15.5"	30"	12.75"	17	\$157
FTFSH.1336	15.5"	36"	12.75"	17	\$165
FTFSH.1342	15.5"	42"	12.75"	18	\$175
FTFSH.1348	15.5"	48"	12.75"	19	\$177

**DESCRIPTION & NOTES**

**DESCRIPTION:**  
 This shelf hangs from a frame or wall strips.

Includes attachment hardware.

Overheads & Shelves continued

**"B" STYLE LOCKING FABRIC FLIPPER UNIT**

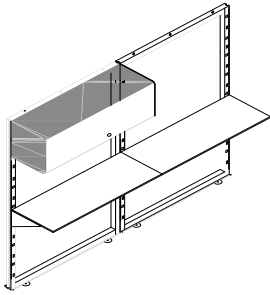

PART #	HEIGHT	WIDTH	DEPTH	WT. (LBS)	PRICE
FTFFLU.1324L	15.5"	24"	12.75"	27	\$470
FTFFLU.1330L	15.5"	30"	12.75"	31	\$490
FTFFLU.1336L	15.5"	36"	12.75"	33	\$519
FTFFLU.1342L	15.5"	42"	12.75"	36	\$550
FTFFLU.1348L	15.5"	48"	12.75"	39	\$575

DESCRIPTION & NOTES

DESCRIPTION:  
This lockable storage cabinet hangs from a frame or wall strips.

Includes a fabric front, a lock, and attaching hardware.

- NOTES:
- Lock finish: Black.
  - See fabrics on page 4.

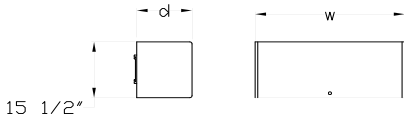

**"B" STYLE LOCKING PAINTED FLIPPER UNIT**

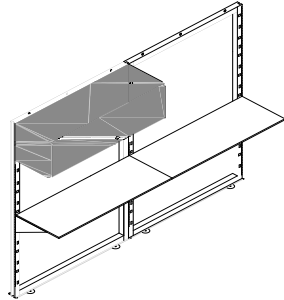

PART #	HEIGHT	WIDTH	DEPTH	WT. (LBS)	PRICE
FTPFLU.1324L	15.5"	24"	12.75"	27	\$307
FTPFLU.1330L	15.5"	30"	12.75"	31	\$329
FTPFLU.1336L	15.5"	36"	12.75"	33	\$366
FTPFLU.1342L	15.5"	42"	12.75"	36	\$382
FTPFLU.1348L	15.5"	48"	12.75"	39	\$408

DESCRIPTION & NOTES

DESCRIPTION:  
This lockable storage cabinet hangs from a frame or wall strips.

Includes a metal painted front, a lock, and attaching hardware.

- NOTES:
- Lock finish: Black.
  - Specify finish.

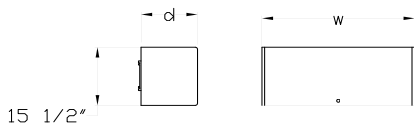



## Frameless Glass



### DESCRIPTION

Frameless glass screens are attached to the top of a single frame.

### NOTES

- Includes attachment hardware with-brushed finish.
- Includes top cap — specify finish.
- Package contains 2.

### SPECIFICATION OPTIONS

**product #:** see charts below  
**top cap finish:** LG Light Gray, BU Black Umber

### ORDER EXAMPLE

**product #:** FTFG.0824-CL  
**top cap finish:** LG Light Gray

### 8" HIGH CLEAR

PART #	HEIGHT	WIDTH	DEPTH	WT. (LBS)	PRICE
FTFG.0824-CL	8"	23-1/4"	—	—	\$302
FTFG.0830-CL	8"	29-1/4"	—	—	\$316
FTFG.0836-CL	8"	35-1/4"	—	—	\$354
FTFG.0842-CL	8"	41-1/4"	—	—	\$378
FTFG.0848-CL	8"	47-1/4"	—	—	\$404

### 14" HIGH CLEAR

PART #	HEIGHT	WIDTH	DEPTH	WT. (LBS)	PRICE
FTFG.1424-CL	14"	23-1/4"	—	—	\$364
FTFG.1430-CL	14"	29-1/4"	—	—	\$392
FTFG.1436-CL	14"	35-1/4"	—	—	\$442
FTFG.1442-CL	14"	41-1/4"	—	—	\$478
FTFG.1448-CL	14"	47-1/4"	—	—	\$518

### 8" HIGH FROSTED

PART #	HEIGHT	WIDTH	DEPTH	WT. (LBS)	PRICE
FTFG.0824-FR	8"	23-1/4"	—	—	\$332
FTFG.0830-FR	8"	29-1/4"	—	—	\$366
FTFG.0836-FR	8"	35-1/4"	—	—	\$418
FTFG.0842-FR	8"	41-1/4"	—	—	\$460
FTFG.0848-FR	8"	47-1/4"	—	—	\$502

### 14" HIGH FROSTED

PART #	HEIGHT	WIDTH	DEPTH	WT. (LBS)	PRICE
FTFG.1424-FR	14"	23-1/4"	—	—	\$446
FTFG.1430-FR	14"	29-1/4"	—	—	\$506
FTFG.1436-FR	14"	35-1/4"	—	—	\$584
FTFG.1442-FR	14"	41-1/4"	—	—	\$650
FTFG.1448-FR	14"	47-1/4"	—	—	\$722

## Frameless Glass for Change of Height



### DESCRIPTION

Frameless glass screens are attached to the top of a single frame at a change of height location.

### NOTES

- Includes attachment hardware with-brushed finish.
- Includes top cap — specify finish.
- Package contains 2.
- Contact factory for lead times.

### SPECIFICATION OPTIONS

**product #:** see charts below  
**top cap finish:** LG Light Gray, BU Black Umber

### ORDER EXAMPLE

**product #:** FTFGC.0824-CL  
**top cap finish:** LG Light Gray

### 8" HIGH CLEAR

PART #	HEIGHT	WIDTH	DEPTH	WT. (LBS)	PRICE
FTFGC.0824-CL	8"	22-1/2"	—	—	\$302
FTFGC.0830-CL	8"	28-1/2"	—	—	\$316
FTFGC.0836-CL	8"	34-1/2"	—	—	\$354
FTFGC.0842-CL	8"	40-1/2"	—	—	\$378
FTFGC.0848-CL	8"	46-1/2"	—	—	\$404

### 14" HIGH CLEAR

PART #	HEIGHT	WIDTH	DEPTH	WT. (LBS)	PRICE
FTFGC.1424-CL	14"	22-1/2"	—	—	\$364
FTFGC.1430-CL	14"	28-1/2"	—	—	\$392
FTFGC.1436-CL	14"	34-1/2"	—	—	\$442
FTFGC.1442-CL	14"	40-1/2"	—	—	\$478
FTFGC.1448-CL	14"	46-1/2"	—	—	\$518

### 8" HIGH FROSTED

PART #	HEIGHT	WIDTH	DEPTH	WT. (LBS)	PRICE
FTFGC.0824-FR	8"	22-1/2"	—	—	\$332
FTFGC.0830-FR	8"	28-1/2"	—	—	\$366
FTFGC.0836-FR	8"	34-1/2"	—	—	\$418
FTFGC.0842-FR	8"	40-1/2"	—	—	\$460
FTFGC.0848-FR	8"	46-1/2"	—	—	\$502

### 14" HIGH FROSTED

PART #	HEIGHT	WIDTH	DEPTH	WT. (LBS)	PRICE
FTFGC.1424-FR	14"	22-1/2"	—	—	\$446
FTFGC.1430-FR	14"	28-1/2"	—	—	\$506
FTFGC.1436-FR	14"	34-1/2"	—	—	\$584
FTFGC.1442-FR	14"	40-1/2"	—	—	\$650
FTFGC.1448-FR	14"	46-1/2"	—	—	\$722

# Components

DESCRIPTION	SPECIFICATION OPTIONS
NOTES	ORDER EXAMPLE

**product #:** see charts below

**product #:** FLED.20

## LED TASKLIGHT



PART #	HEIGHT	WIDTH	DEPTH	WT. (LBS)	PRICE
FLED.20	0.75"	20"	1"	1	\$149
FLED.38	0.75"	38"	1"	2	\$195

### DESCRIPTION & NOTES

**DESCRIPTION:**  
Attaches beneath a shelf or flipper unit. Includes an LED light, power cord and installation hardware. Has a pivot range of +/-15°.

- NOTES:**
- For overheads 24"-36" use FLED.20.
  - For overheads 42" or wider use FLED.38
  - Finish: Silver

## WIRE MANAGER

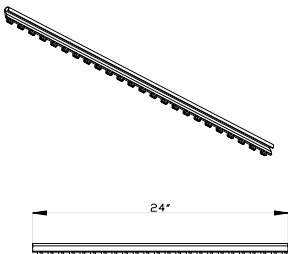

PART #	HEIGHT	WIDTH	DEPTH	WT. (LBS)	PRICE
FTWM.24	24"	.5"		2	\$64

### DESCRIPTION & NOTES

**DESCRIPTION:**  
This Wire Manager is used to manage electrical cords vertically. It fits between side by side tiles, or between a tile and a connector. It hangs on the frame slots.

- NOTES:**
- Package contains 4 wire managers.
  - Finish: Black

## PENCIL DRAWER

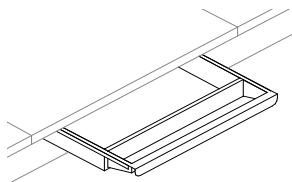

PART #	HEIGHT	WIDTH	DEPTH	WT. (LBS)	PRICE
FTPD	1.875"	21.125"	16.25"	5	\$143

### DESCRIPTION & NOTES

**DESCRIPTION:**  
Stores small items. Attaches to the underside of a worksurface.

Includes attachment hardware.

- NOTES:**
- Only available in MT Medium Tone or DT Dark Tone.

## TILES

## Pedestals

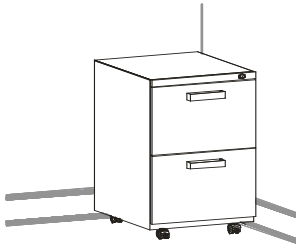

## DESCRIPTION

Storage with drawers.

## SPECIFICATION OPTIONS

**product #:** see charts below

**paint finish:** LG Light Gray, BU Black Umber

## NOTES

- metal with painted finish
- square drawer front

## ORDER EXAMPLE

**product #:** FPEDSQP.BBF-MET

**paint finish:** LG Light Gray

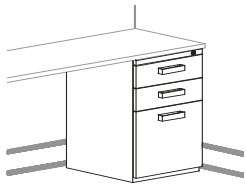
BOX / BOX / FILE  
PEDESTAL

PART #	HEIGHT	WIDTH	DEPTH	WT. (LBS)	PRICE
FPEDSQP.BBF-MET	27"	15"	20"	56	\$530

## DESCRIPTION &amp; NOTES

**DESCRIPTION:**  
Supporting metal pedestal, with lock, without top cap. Attaches to the underside of a work surface.

## NOTES:

- For side to side filing order side to side file bars.

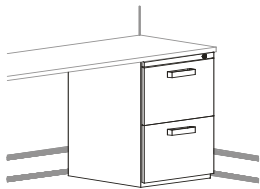
FILE / FILE  
PEDESTAL

PART #	HEIGHT	WIDTH	DEPTH	WT. (LBS)	PRICE
FPEDSQP.FF-MET	27"	15"	20"	53	\$530

## DESCRIPTION &amp; NOTES

**DESCRIPTION:**  
Supporting metal pedestal, with lock, without top cap. Attaches to the underside of a work surface.

## NOTES:

- For side to side filing order side to side file bars.

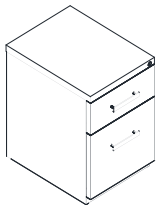
BOX / FILE  
PEDESTAL

PART #	HEIGHT	WIDTH	DEPTH	WT. (LBS)	PRICE
FPEDSQP.BF-MOB-MET	22"	15"	20"	85	\$581

## DESCRIPTION &amp; NOTES

**DESCRIPTION:**  
Free-standing mobile pedestal with lock and with top cap.

## NOTES:

- For side to side filing order side to side file bars.

**BOX / BOX / FILE  
PEDESTAL MOBILE**

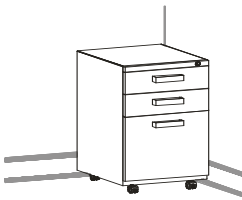

PART #	HEIGHT	WIDTH	DEPTH	WT. (LBS)	PRICE
FPEDSQP.BBF-MOB-MET	27.25"	15"	20"	85	\$689

DESCRIPTION & NOTES

DESCRIPTIONS  
Freestanding mobile pedestal with lock and with top cap.

- NOTES:
- For side to side filing order side to side file bars.

**FILE / FILE  
PEDESTAL MOBILE**

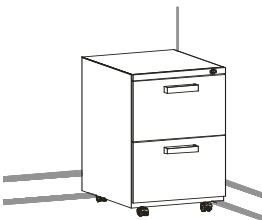

PART #	HEIGHT	WIDTH	DEPTH	WT. (LBS)	PRICE
FPEDSQP.FF-MOB-MET	27.25"	15"	20"	76	\$689

DESCRIPTION & NOTES

DESCRIPTION:  
Freestanding mobile pedestal with lock and with top cap.

- NOTES:
- For side to side filing order side to side file bars.

**BOX / FILE PEDESTAL  
MOBILE CUSHION**

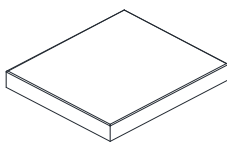

PART #	HEIGHT	WIDTH	DEPTH	WT. (LBS)	PRICE
FPEDSQ.CUSH	1.75"	15"	20"	—	\$265

DESCRIPTION & NOTES

DESCRIPTION:  
For Box/File mobile pedestal only.

- NOTES:
- If cushion is placed on a full height mobile pedestal, it will not fit under a worksurface.

**SIDE-TO-SIDE FILE BAR**

PART #	HEIGHT	WIDTH	DEPTH	WT. (LBS)	PRICE
FSSB	-	-	-	1	\$16

DESCRIPTION & NOTES

DESCRIPTION:  
Side to side file bar, for filing letter or legal size folders.

- NOTES:
- For side to side filing order 1 per file drawer.
  - Finish: Black

## Lateral Files

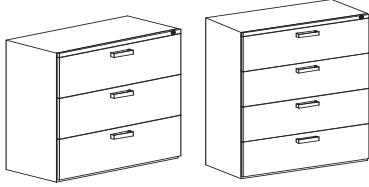
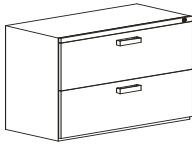

## DESCRIPTION

Storage with drawers.

## SPECIFICATION OPTIONS

**product #:** see charts below  
**paint finish:** LG Light Gray, BU Black Umber

## NOTES

- metal with painted finish
- square drawer front
- Freestanding 3 and 4 drawer lateral files must be bolted together or bolted to a wall.

## ORDER EXAMPLE

**product #:** FLFSQP-2-30-MET  
**paint finish:** LG Light Gray

## 2 DRAWER LATERAL FILES

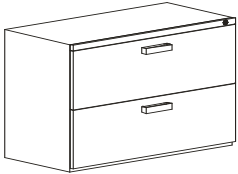

PART #	HEIGHT	WIDTH	DEPTH	WT. (LBS)	PRICE
FLFSQP-2-30-MET	27.5"	30"	20"	103	\$950
FLFSQP-2-36-MET	27.5"	36"	20"	123	\$1,152
FLFSQP-2-42-MET	27.5"	42"	20"	151	\$1,180

## DESCRIPTION &amp; NOTES

**DESCRIPTION:**  
Supporting lateral file with lock and finished top cap.

## NOTES:

- For front to back filing order front to back file bars.
- To convert to a Freestanding Lateral File, order counterweight.

## FREESTANDING 3 DRAWER LATERAL FILE WITH TOP CAP

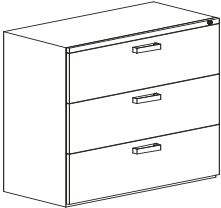

PART #	HEIGHT	WIDTH	DEPTH	WT. (LBS)	PRICE
FLFSQP-3-30-MET	40"	30"	20"	121	\$1,230
FLFSQP-3-36-MET	40"	36"	20"	151	\$1,389
FLFSQP-3-42-MET	40"	42"	20"	181	\$1,511

## DESCRIPTION &amp; NOTES

**DESCRIPTION:**  
Freestanding Lateral File with lock and finished top cap.

## NOTES:

- **Freestanding lateral files must be bolted to a wall or bolted together.**
- For front to back filing order front to back file bars.
- If needed, order counterweight separately.
- **Load bottom drawer first.**

**FREESTANDING  
4 DRAWER LATERAL  
FILE WITH TOP CAP**



PART #	HEIGHT	WIDTH	DEPTH	WT. (LBS)	PRICE
FLFSQP-4-30-MET	51.5"	30"	20"	173	\$1,558
FLFSQP-4-36-MET	51.5"	36"	20"	196	\$1,712
FLFSQP-4-42-MET	51.5"	42"	20"	241	\$1,871

**DESCRIPTION & NOTES**

**DESCRIPTION:**  
Freestanding lateral file with lock and finished top cap.

- NOTES:**
- Freestanding lateral files must be bolted to a wall or bolted together.
  - For front to back filing order front to back file bars.
  - If needed, order counterweight separately.
  - Load bottom drawer first.

**LATERAL FILE  
COUNTERWEIGHT**

PART #	HEIGHT	WIDTH	DEPTH	WT. (LBS)	PRICE
FLFCW-30	use with 30"W lateral file *			23	\$53
FLFCW-36	use with 36"W lateral file **			46	\$80
FLFCW-42	use with 42"W lateral file **			46	\$80

**DESCRIPTION & NOTES**

**DESCRIPTION:**  
Attaches securely to the inside back of the lateral file.

- NOTES:**
- \*Includes one 20lb counterweight
  - \*\*Includes two 20lb counterweights for a total of 40lbs of counterweight
  - Attaches securely to the inside back of the lateral file.
  - For use with 2 drawer lateral files only.

**FRONT TO BACK  
FILE BARS**

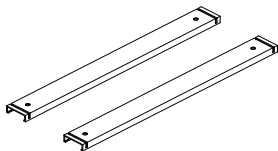

PART #	HEIGHT	WIDTH	DEPTH	WT. (LBS)	PRICE
FFB	3/8"	1 3/16"	15 11/16"	1	\$21

**DESCRIPTION & NOTES**

**NOTES:**

- Sold in packages of 2.
- Order 1 package of 2 per drawer.
- Finish: Black.

## Accessories

DESCRIPTION	SPECIFICATION OPTIONS
	<b>product #:</b> see charts below <b>paint finish:</b> LG Light Gray, BU Black Umber
NOTES	ORDER EXAMPLE
	<b>product #:</b> FFPT <b>paint finish:</b> LG Light Gray

### TOOL BAR

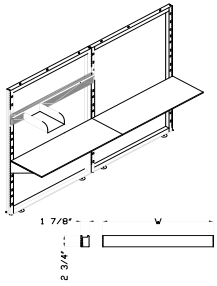

PART #	HEIGHT	WIDTH	DEPTH	WT. (LBS)	PRICE	DESCRIPTION & NOTES
FTTB.24	2.75"	24"	—	2	\$61	DESCRIPTION: Tool bar attaches to a frame, or to wall strips.
FTTB.30	2.75"	30"	—	2	\$74	
FTTB.36	2.75"	36"	—	3	\$87	NOTES: • Specify tool bar width the same as the frame. • Order rail tools separately.
FTTB.42	2.75"	42"	—	3	\$100	
FTTB.48	2.75"	48"	—	4	\$112	

### FLAT PAPER TRAY

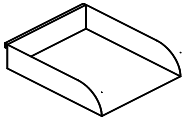

PART #	HEIGHT	WIDTH	DEPTH	WT. (LBS)	PRICE	DESCRIPTION & NOTES
FFPT	3"	10"	12"	2	\$74	NOTES: • Order Tool Bar separately.

### VERTICAL SINGLE TRAY

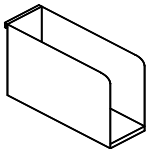

PART #	HEIGHT	WIDTH	DEPTH	WT. (LBS)	PRICE	DESCRIPTION & NOTES
FVST	8"	4"	12"	2	\$74	NOTES: • Order Tool Bar separately.

### VERTICAL TRIPLE TRAY

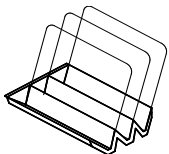

PART #	HEIGHT	WIDTH	DEPTH	WT. (LBS)	PRICE	DESCRIPTION & NOTES
FVTT	11"	12"	12"	4	\$90	NOTES: • Order Tool Bar separately.

### CARPET GRIPPER

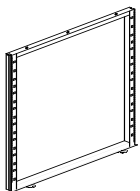

PART #	HEIGHT	WIDTH	DEPTH	WT. (LBS)	PRICE	DESCRIPTION & NOTES
FTCG		2.125"		0.25	\$5	DESCRIPTION: Plastic Gripper fits onto the adjustable glides of frames.  NOTES: • Do not use on hard surface flooring. • Color: Black.



# Keyed-Alike

<p>DESCRIPTION</p> <hr/>	<p>SPECIFICATION OPTIONS</p> <p><b>product #:</b> see charts below</p>
<p>NOTES</p> <hr/>	<p>ORDER EXAMPLE</p> <p><b>product #:</b> FLCKA</p>

## KEYED ALIKE LOCKS

PART #	HEIGHT	WIDTH	DEPTH	WT. (LBS)	PRICE	DESCRIPTION & NOTES
FLCKA					<b>\$100</b>	<p>DESCRIPTION: All Friant pedestals, lateral files, and overhead cabinets can be keyed alike.</p> <p>NOTES:</p> <ul style="list-style-type: none"> <li>Keyed-alike lock cores are sold in sets of 4.</li> <li>Each set includes 4 lock cores, each with 2 keys, all with the same lock number.</li> <li>One lock core removal key is shipped with every order.</li> </ul>
FCK					<b>\$15</b>	
FMK					<b>\$15</b>	



**FRIANT** DESIGN <sup>IS</sup> BUSINESS  
SENSE MEETS SENSE

4901 EAST 12th St / Oakland / California 94601 / T: 510.535.5113 / F: 510.535.5237 / friant.com

