

2930 South Fairview Street
 Santa Ana, CA 92704
 Phone: 714 668 3660
 Fax: 714 668 1107
 Email: sales@allscape.net

INSTALLATION SHEET

Safety, Warnings and Suggestions

- ¹ Care should be taken not to position fixtures in locations where bare skin can come into contact with the potentially high temperatures on the lens.
- ² Avoid installing fixtures in locations where water collects and stands for prolonged periods.
- ³ Make sure that electrical power is disconnected before any work is performed.
- ⁴ All gaskets and sealing surfaces must be kept clean during installation.
- ⁵ As a rule of thumb, the higher the fixture is mounted above grade potential problems such as foliage over growth or water, mud etc. collecting on the lens are reduced.
- ⁶ All wiring and installation should meet local, state and national electrical codes.
- ⁷ This will help prevent wire connector corrosion due to water penetration from the conduit.
- ⁸ Install correct lamp type and wattage.
- ⁹ If condensation, built up during installation, is visible on the lens it is recommended that the fixture be turned on before the lens ring is fully secured for approximately 30 minutes. This should allow the condensation to be exhausted.

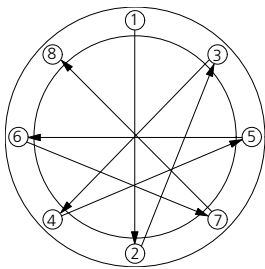

Use several rotations of the following sequence to tighten the lens ring screws, to 40 in/lbs. max.

Mount Fixture as high above grade as possible to prevent debris and water standing on fixture surface.

Create an isolation barrier around the fixture to prevent rocks and foliage from interfering with light output.

Add drainage media below and around fixture to prevent standing water.

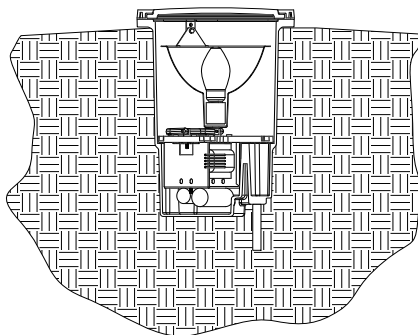

SL-43 In Soil

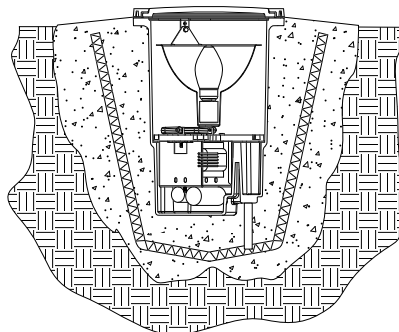

SL-43 In Soil With Concrete Base and Trim Ring

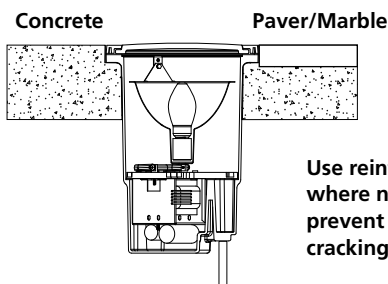

SL-43 In Concrete With Trim Ring

Use reinforcement where necessary to prevent concrete cracking.

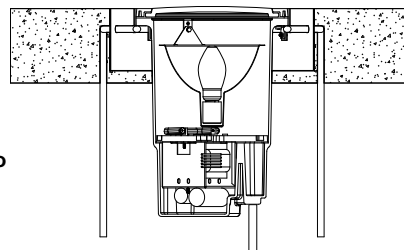

SL-43 In Concrete With Grout Mask and Trim ring

1. Prepare the site with adequate excavation to install fixtures¹. Drainage media below fixture will enhance installation^{2,3}.

2. Remove lens ring and lens with gasket,⁴ reflector assembly and "D" shaped splice box cover plate and gasket.

3. Position fixture so it is flush or just above the installation area grade⁵ and orient the fixture with regard to architectural requirements to obtain the appropriate accent.

4. Connect conduit to the 3/4" NPT openings in the splice compartment at the bottom of the fixture, using the appropriate thread sealing compound. Tighten to 15 ft-lbs. max.

5. Make power and ground connections using provided waterproof wirenuts. It is recommended that RTV Silicone or other re-enterable water sealing compound be used to seal the conduit entry points⁷.

6. Reinstall "D" shaped splice box cover plate and gasket ensuring that all four (4) screws are securely tightened.⁴ Reinstall reflector assembly, install lamp⁸ and make aiming adjustments.

7. Install lens ring and lens with gasket⁴ IMPORTANT! A CRISS CROSS PATTERN IS REQUIRED TO ENSURE THAT A GOOD COMPRESSION SEAL IS MADE. If this is not accomplished the fixture could leak and be damaged. Tighten screws gradually using multiple tightening steps up to 40 in/lbs. max.