

INSTALLATION INSTRUCTIONS

Dorah Hammered Copper Japanese Style Air Bath Soaking Tub with Rings

- Install so that the security device, MANI-SD-A, is at least 2" above tub rim.

Components List:

- BM-TWP Ball Check Valve Jets
- MANI-SD-A Security Device
- MAN-A-4-AC Manifold
- Silver SLS+ Variable Speed Blower

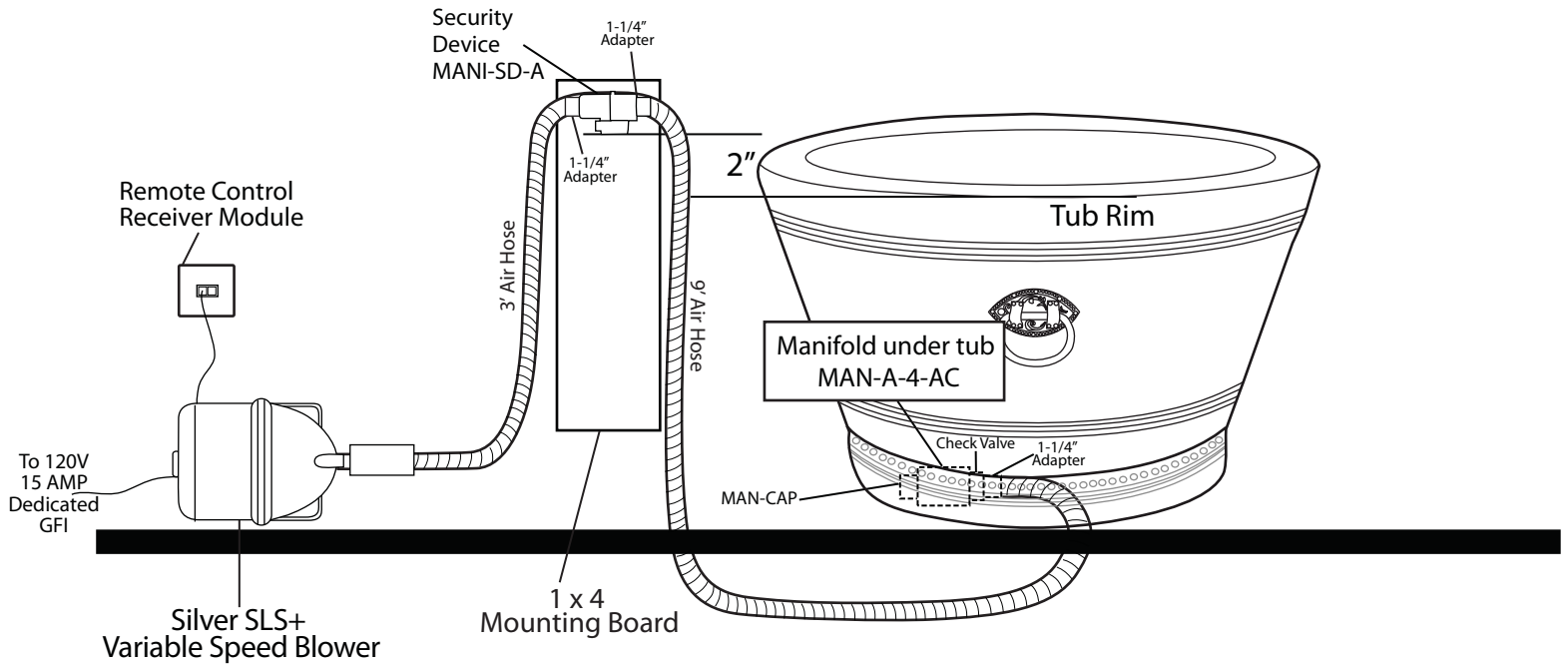

Inside of Bath

Features:

- (12) Maxi Air Jets with 24 openings



Elbows for air jets Tees for air jets

- Remote Control CG+/RTC-SENSOR-WP



12-15 year battery life

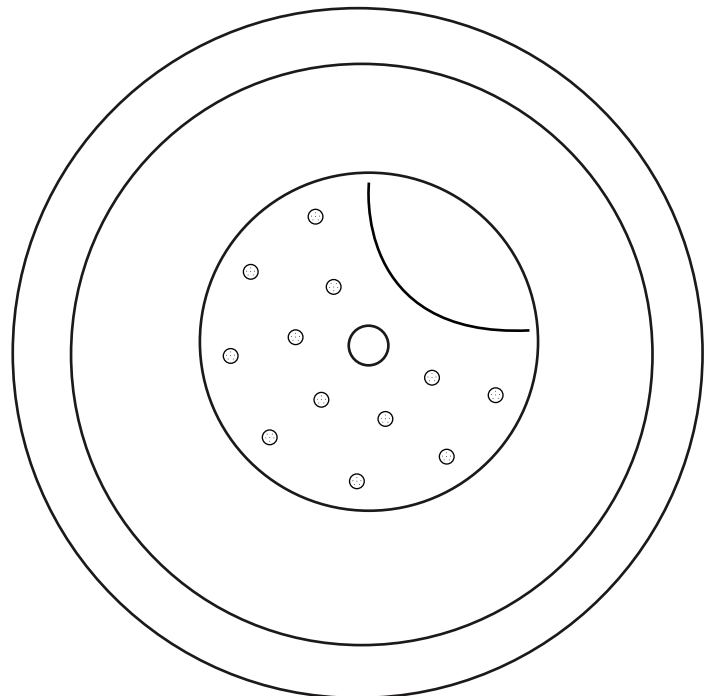

Dorah Hammered Copper Japanese Style Soaking Tub with Rings

Hammered Exterior and Interior.

Tub Dimensions: 47-1/2" L x 45-1/2" W x 34" H.

Water Capacity: 82 Gallons to the top of tub.

Tub Weight Uncrated: 200 lbs. Tub Weight Crated: 425 lbs.

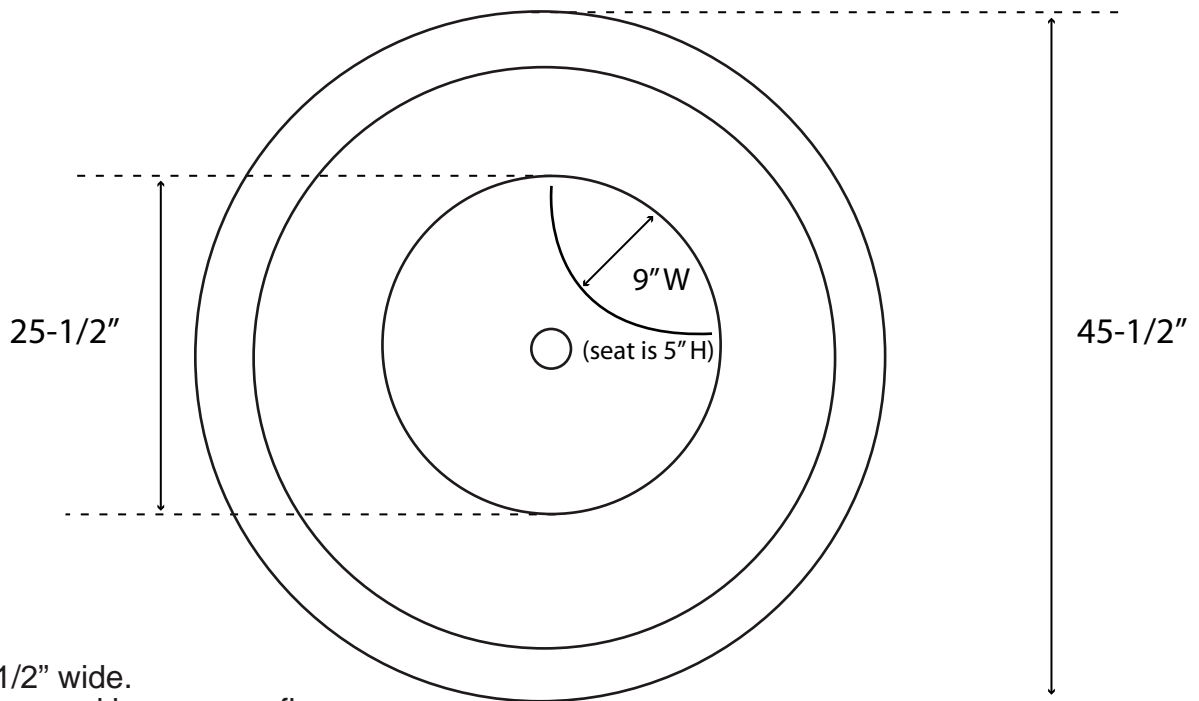
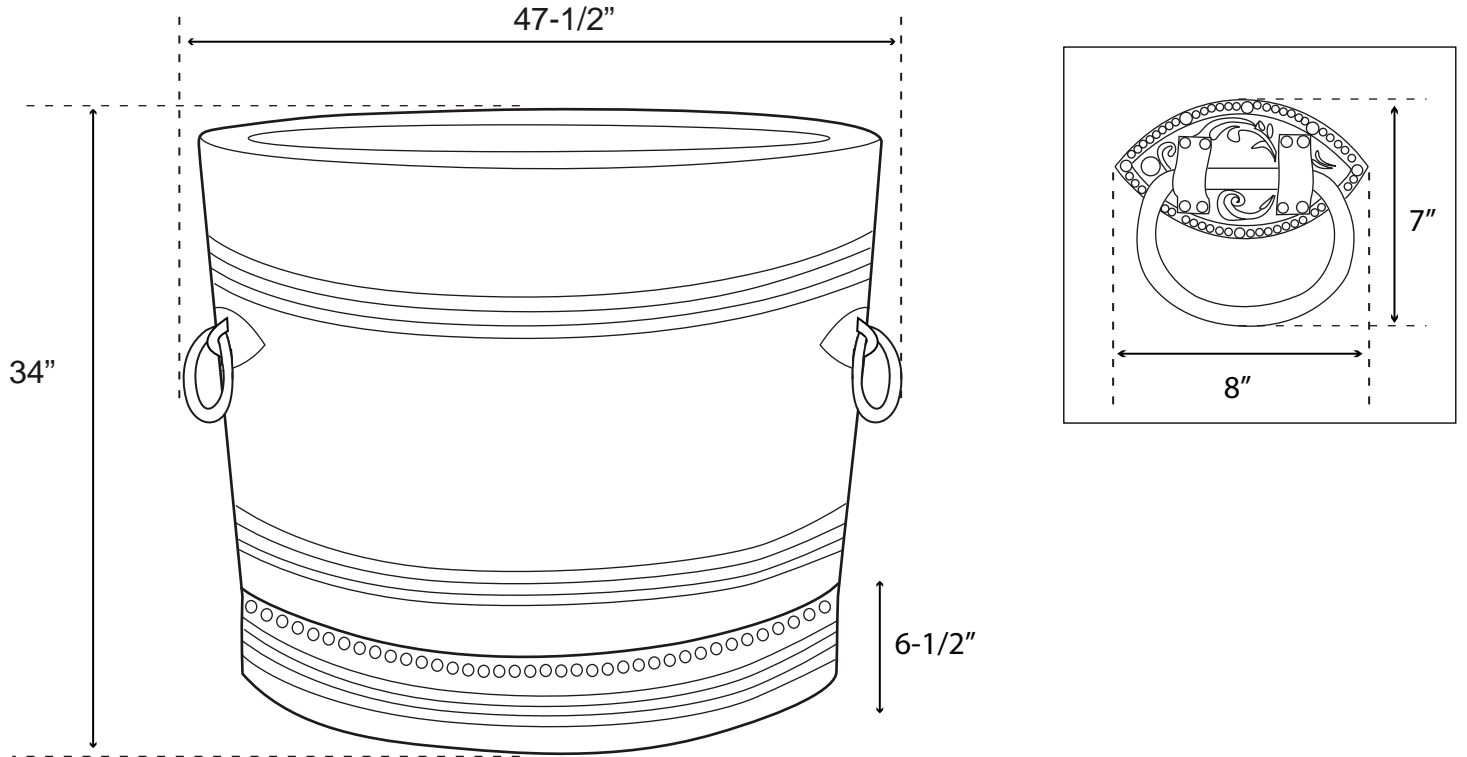

Tub rim is 3-1/2" wide.

Tub is 29" deep and has no overflow.

Interior tub seat measures 16" L x 9" W x 5" H.

All measurements are approximate. Measurements may vary +/- 1/2".