

Viking Installation Guide



Viking Range Corporation

111 Front Street

Greenwood, Mississippi 38930 USA

(662) 455-1200

For product information,

call 1-888-VIKING1 (845-4641)

or visit the Viking Web site at

vikingrange.com

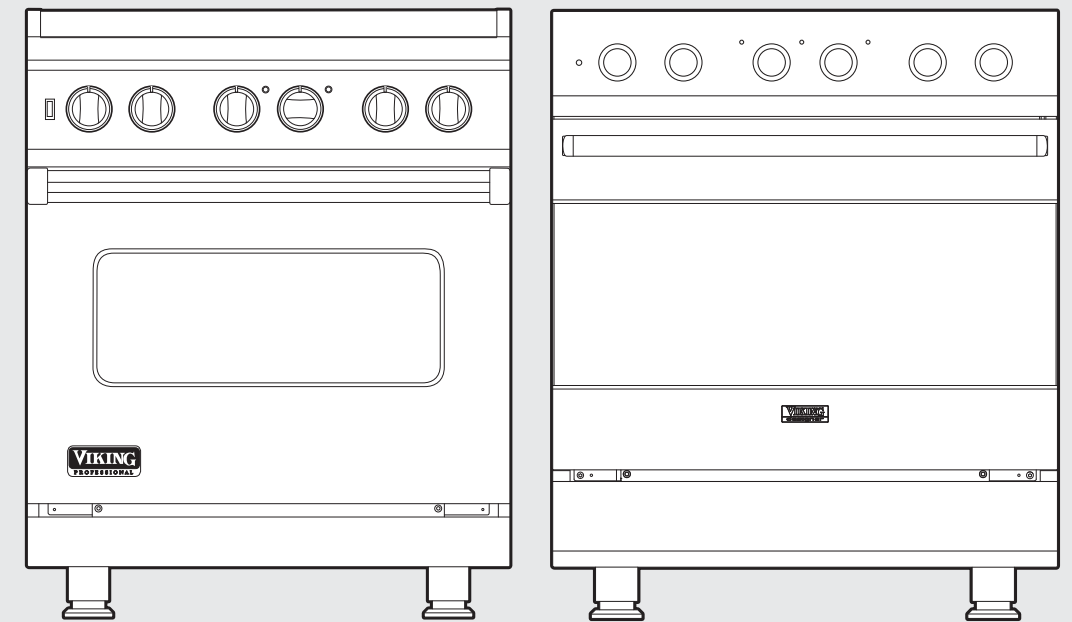

Professional & Designer
Freestanding 30" Electric Range



Table of Contents

Warnings & Important Safety Instructions _____	3
Dimensions _____	6
Specifications _____	7
Clearance Dimensions (Proximity to Cabinets) _____	8
Clearance Dimensions (Wood/Composite Overlay) _____	9
Electrical Requirements _____	10
General Information _____	11
Installation _____	12
Door Removal _____	12
Leg Installation _____	13
Electrical Connection (3-wire) _____	14
Electrical Connection (4-wire) _____	16
Leveling/Adjustments/Alignment _____	18
Anti-tip Device Installation _____	19
Final Installation _____	20
Door Replacement and Adjustment _____	21
Final Preparation _____	22
Performance Checklist _____	22
Service & Registration _____	23

IMPORTANT—Read and Follow!

- Before beginning, please read these instructions completely and carefully.
- Do not remove permanently affixed labels, warnings, or plates from product. This may void the warranty.
- All local and national codes and ordinances must be observed. Installation must conform with local codes or in the absence of codes, the National Fuel Gas Code ANSI Z223.1/NFPA-54 –latest edition.
- The installer must leave these instructions with the consumer who should retain for local inspector’s use and for future reference.

In Canada: Installation must be in accordance with the current CSA C22.1 Canadian Electrical Codes Part 1 and/or local codes.

Your safety and the safety of others is very important.

We have provided many important safety messages in this manual and on your appliance. Always read and obey all safety messages.

 This is the safety alert symbol. This symbol alerts you to hazards that can kill or hurt you and others.

All safety messages will be preceded by the safety alert symbol and the word “DANGER,” “WARNING” or “CAUTION.” These words mean:

DANGER

Hazards or unsafe practices which WILL result in severe personal injury or death

WARNING

Hazards or unsafe practices which COULD result in severe personal injury or death

CAUTION

Hazards or unsafe practices which COULD result in minor personal injury or property damage.

All safety messages will identify the hazard, tell you how to reduce the chance of injury, and tell you what can happen if the instructions are not followed.

IMPORTANT—Read and Follow!

A GFI shall be used if required by NFPA-70 (National Electric Code), federal/state/local laws, or local ordinances.

- The required use of a GFI is normally related to the location of a receptacle with respect to any significant sources of water or moisture.
- Viking Range Corporation will NOT warranty any problems resulting from GFI outlets which are not installed properly or do not meet the requirements below.

If the use of a GFI is required, it should be:

- Of the receptacle type (breaker type or portable type NOT recommended)
- Used with permanent wiring only (temporary or portable wiring NOT recommended)
- On a dedicated circuit (no other receptacles, switches or loads in the circuit)
- Connected to a standard breaker of appropriate size (GFI breaker of the same size NOT recommended)
- Rated for Class A (5 mA +/- 1 mA trip current) as per UL 943 standard
- In good condition and free from any loose-fitting gaskets (if applicable in outdoor situations)
- Protected from moisture (water, steam, high humidity) as much as reasonably possible

⚠ WARNING

To prevent possible damage to cabinets and cabinet finishes, use only materials and finishes that will not discolor or delaminate and will withstand temperatures up to 194°F (90°C). Heat resistant adhesive must be used if the product is to be installed in laminated cabinetry. Check with your builder or cabinet supplier to make sure that the materials meet these requirements.

⚠ DANGER



ELECTRICAL SHOCK HAZARD

To avoid risk of electrical shock, personal injury or death; verify your appliance has been properly grounded in accordance with local codes or in absence of codes, with the National Electrical Code (NEC). ANSI/NFPA 70-latest edition.

⚠ WARNING



MOVING HAZARD

To avoid risk of severe personal injury; this appliance requires two or more personnel while handling and moving. Possible use of appliance moving devices is recommended.

⚠ WARNING



TIPPING HAZARD

To reduce the risk of the appliance tipping, it must be secured by a properly installed anti-tip bracket(s). To make sure the bracket has been installed properly, look behind the range with a flashlight to verify proper installation engaged in the rear

- top left corner of the range.
- THIS RANGE CAN TIP.
- INJURIES TO PERSONS CAN RESULT.
- INSTALL ANTI-TIP DEVICE PACKED WITH RANGE.
- SEE INSTALLATION INSTRUCTIONS.

Dimensions

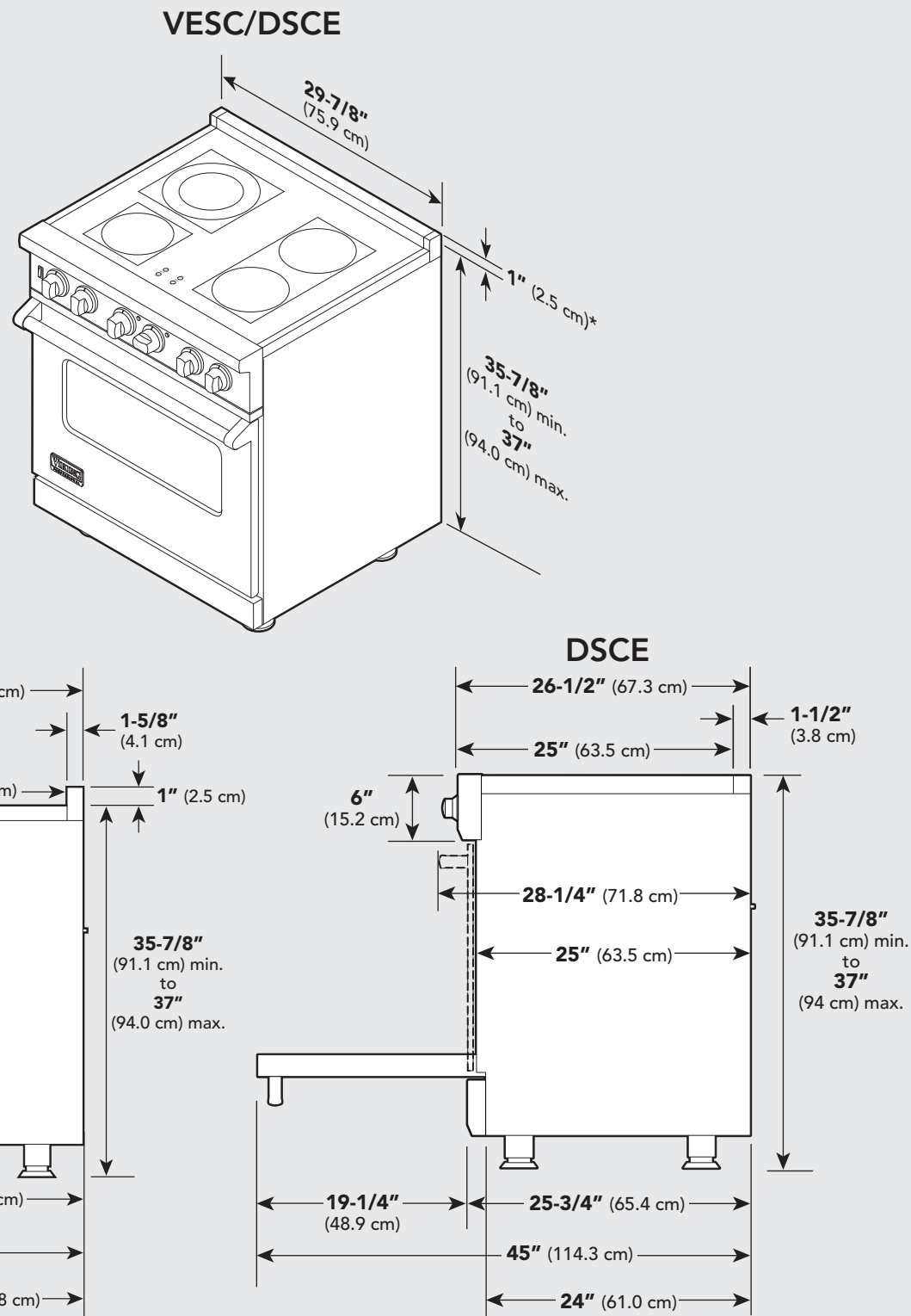

*Note: Units shown with standard island trim.

Specifications

Electric 30" Range		
Description	VESC530-4B	DSCE130-4B
Overall width	29-7/8" (75.9 cm)	
Overall height	To top of glass frame 35-7/8" (91.1 cm) min. 37" (94.0 cm) max. Legs adjust 1-1/8" (2.9 cm)	
Overall depth from rear	To end of side panel—24-5/16" (61.8 cm) To front of door—25-3/4" (65.4 cm) To end of landing ledge—28-1/16" (71.3 cm) To end of door handle—28-11/16" (72.9 cm)	To end of side panel—25" (63.5 cm) To front of door—25-3/4" (65.4 cm) To end of landing ledge—26-1/2" (67.3 cm) To end of door handle—28-1/4" (71.8 cm)
Additions to base height	To top of island trim—add 1" (2.5 cm) To top of backguard—add 8" (20.3 cm) To top of high-shelf—add 23-1/2" (59.7 cm)	To top of island trim—add 0" (0.0 cm) To top of backguard—add 6" (15.2 cm) To top of high-shelf—add 18-3/16" (46.2 cm)
Electrical requirements	See Electrical Requirements information.	
Maximum amp usage	240V—59.0 amps 208V—51.3 amps	
Surface element rating	Left front Bridge Left rear Right front Bridge Right rear	1,800 watts 800 watts 1,800 watts 1,500 watts 800 watts 1,800 watts
Oven interior width	25-5/16" (64.6 cm)	
Oven interior height	16-1/2" (41.9 cm)	
Oven interior depth	AHAM 16-13/16" (42.7 cm) Overall—19-1/2" (49.5 cm)	
Oven volume	Total oven capacity—4.7 cu. ft. Measure to AHAM standards 4.1 cu. ft.	
Approximate shipping weight	426 lbs. (193.2 kg)	

Minimum clearances from adjacent combustible construction

- Cooking surface and below, i.e., 36" (91.4 cm) and below
 - o Sides—0"
 - o Rear—0" with backguard or highshelf; 0" with island trim and noncombustible rear wall; 6" (15.2 cm) with island trim and combustible rear wall.
- Above cooking surface, i.e. above 36" (91.4 cm)
 - o Sides—6" (15.2 cm)
 - o Within 6" (15.2 cm) side clearance, wall cabinets no deeper than 13" (33.0 cm) must be minimum 18" (45.7 cm) above cooking surface.
 - o Wall cabinets directly above product must be minimum 36" (91.4 cm) for open top burners above cooking surface.

Clearance Dimensions (Proximity to Cabinets)

- This range may be installed directly adjacent to existing 36" (91.4 cm) high base cabinets.
- IMPORTANT:** The side trim MUST be 3/8" (.95 cm) above the adjacent base cabinet countertop. This can be accomplished by raising the unit using the adjustment spindles on the legs.
- The range CANNOT be installed directly adjacent to sidewalls, tall cabinets, tall appliances, or other side vertical surfaces above 36" (91.4 cm) high. There must be a minimum of 6" (15.2 cm) side clearance from the range to such combustible surfaces above the 36" (91.4 cm) counter height.
- Within the 6" (15.2 cm) side clearance to combustible vertical surfaces above 36" (91.4 cm), the maximum wall cabinet depth must be 13" (33.0 cm) and wall cabinets within this 6" (15.2 cm) side clearance must be 18" (45.7 cm) above the 36" (91.4 cm) high countertop.
- Wall cabinets above the range must be a minimum of 42" (106.7 cm) above the range cooking surface for the full width of the range. This minimum height requirement does not apply if a range hood is installed over the cooking surface.

⚠ CAUTION
To prevent possible damage to cabinets and cabinet finishes, use only materials and finishes that will not discolor or delaminate and will withstand temperatures up to 194°F (90°C). Heat and moisture resistant adhesive must be used if the product is to be installed in laminated cabinetry. Check with your builder or cabinet supplier to make sure that the materials meet these requirements.

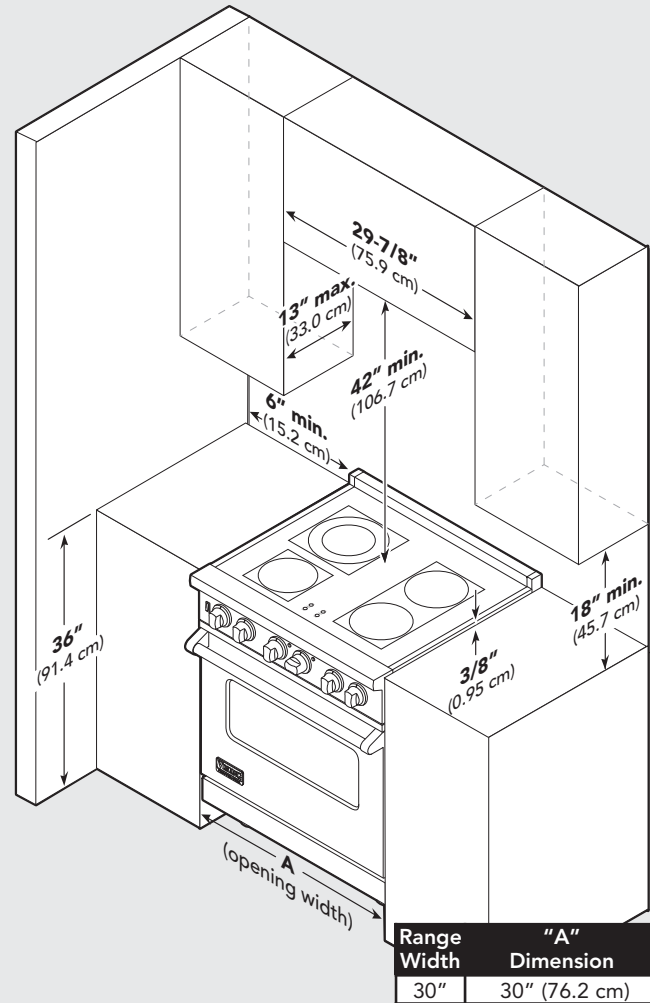

Note: Minimum clearance for back wall is 0" with backguard or high-shelf.

Note: If a range hood is installed, wall cabinets above the range have a different minimum clearance height.

⚠ CAUTION
Burn hazard.
To avoid risk of personal injury; the use of cabinets for storage above the appliance may result in a potential burn hazard. Combustible items may ignite, metallic items may become hot and cause burns. If a cabinet storage is to be provided the risk can be reduced by installing a rangehood that projects horizontally a minimum 5" (12.7 cm) beyond the bottom of cabinets.

Clearance Dimensions (Wood/Composite Overlay)

The bottom of a standard hood should be 30" (76.2 cm) min. to 36" (91.4 cm) max. above the countertop. This would typically result in the bottom of the hood being 66" (167.6 cm) to 72" (182.9 cm) above the floor. Refer to the range hood installation instructions for additional information. These dimensions provide for safe and efficient operation of the hood.

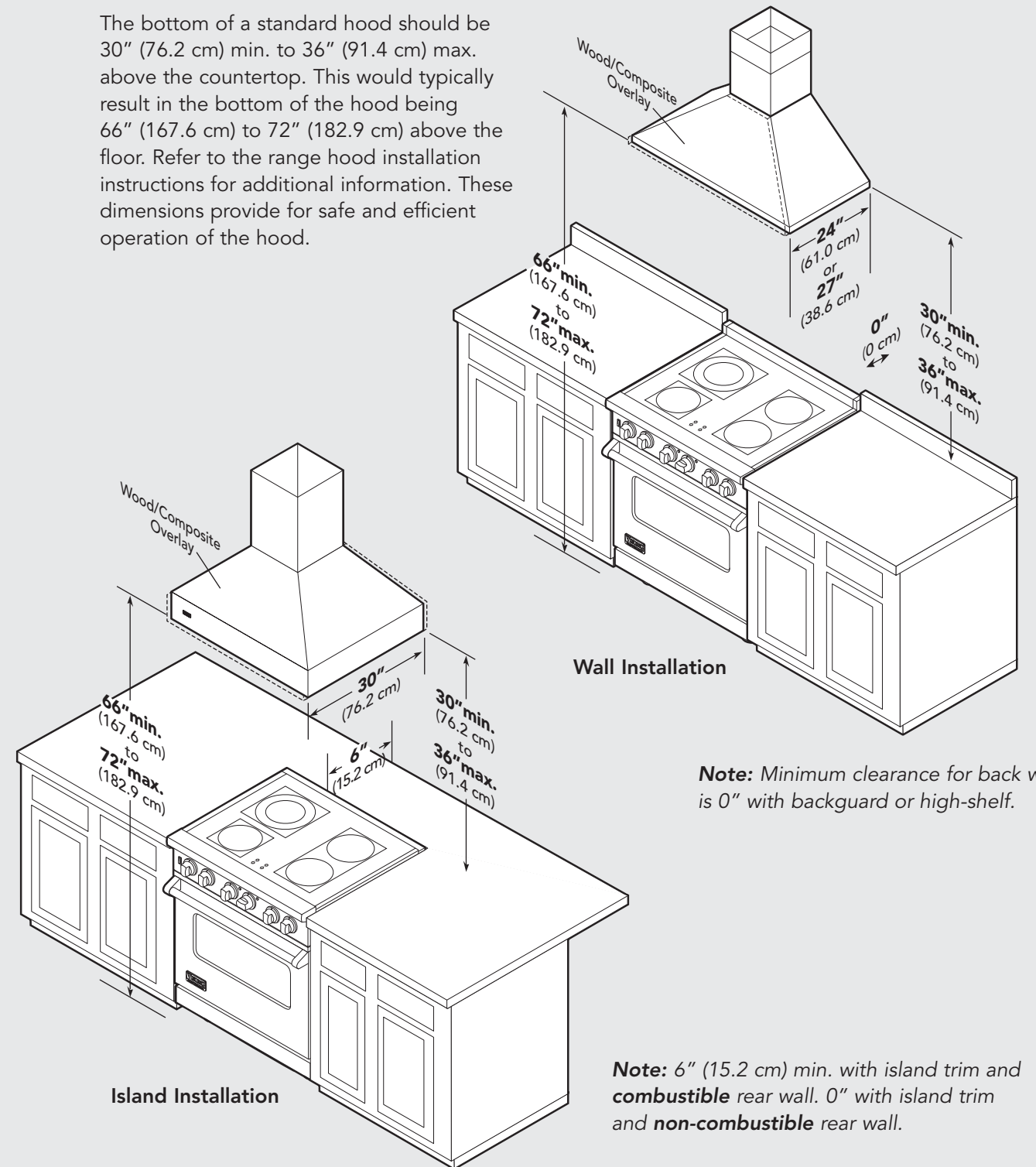

Wall Installation

Note: Minimum clearance for back wall is 0" with backguard or high-shelf.

Island Installation

Note: 6" (15.2 cm) min. with island trim and combustible rear wall. 0" with island trim and non-combustible rear wall.

Electrical Requirements

Electrical Requirements

This product is manufactured with the neutral terminal connected to the cabinet. Use a 3-wire, agency approved, power supply kit with closed loop terminals rated per the National Electrical Code, ANSI/NFPA 70-latest edition (See Rating chart below). If local codes prohibit grounding through the neutral, use a 4-wire, agency approved, power supply kit with closed loop terminals rated per the National Electrical Code, ANSI/NFPA 70-latest edition (See Rating chart below).

RATING* Specified Rating of Power Supply Cord Kit and Circuit Protection

120/240 Volts	120/208 Volts	Amps
12.5 - 16.5 KW	9.2 - 12.5 KW	40 or 50
16.5 - 17.5 KW	12.5 - 13.5 KW	50

*The National Electric Code calculation for Electrical Load is less than the Total Connected Electrical Load listed on the model/serial rating plate.

A GFI shall be used if required by NFPA-70 (National Electric Code), federal/state/local laws, or local ordinances.

- The required use of a GFI is normally related to the location of a receptacle with respect to any significant sources of water or moisture.

- Viking Range Corporation will NOT warranty any problems resulting from GFI outlets which are not installed properly or do not meet the requirements below.

If the use of a GFI is required, it should be:

- Of the receptacle type (breaker type or portable type NOT recommended)
- Used with permanent wiring only (temporary or portable wiring NOT recommended)
- On a dedicated circuit (no other receptacles, switches or loads in the circuit)
- Connected to a standard breaker of appropriate size (GFI breaker of the same size NOT recommended)
- Rated for Class A (5 mA +/- 1 mA trip current) as per UL 943 standard
- In good condition and free from any loose-fitting gaskets (if applicable in outdoor situations)
- Protected from moisture (water, steam, high humidity) as much as reasonably possible

⚠ WARNING

Electrical shock hazard.
To avoid the risk of electrical shock, personal injury or death; verify electrical power is turned off at the breaker box until the range is installed and ready to operate, installation by an authorized installer only.



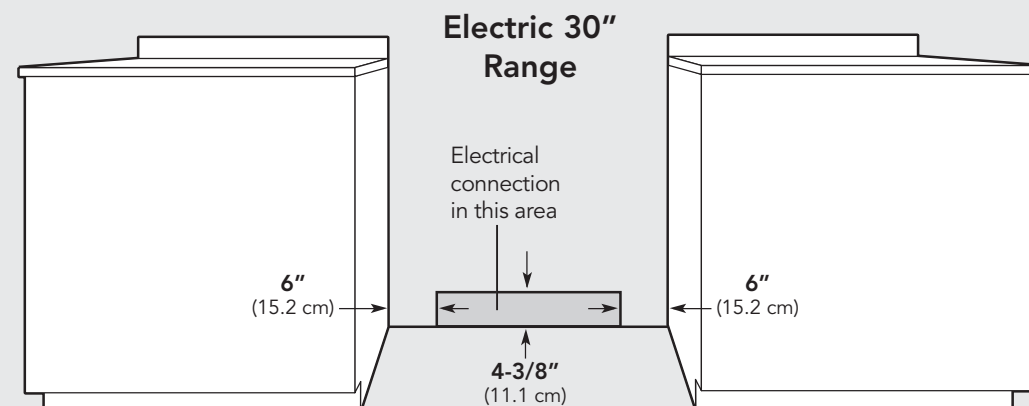

General Information

READ AND FOLLOW ALL WARNING AND CAUTION INFORMATION WHEN INSTALLING THIS APPLIANCE.

- All openings in the wall behind the appliance and in the floor under the appliance must be sealed.
- DO NOT** obstruct the flow of combustion and ventilation air.

⚠ CAUTION

Avoid any damage to oven vents. The vents need to be unobstructed and open to provide proper airflow for optimal oven performance.

⚠ CAUTION

The cooling fan should be operating when the unit is in operation. If you notice the cooling fan is not operating or you observe unusual or excessive noise coming from the cooling fan, contact a Viking Authorized Service Center before continuing operation. Failure to do so can result in damage to the oven or surrounding cabinets.

Moving, Handling, and Unpacking

Remove and discard all packing materials, including cardboard and tape on the outside and inside of the range.

Range – Do not discard the anti-tip metal bracket supplied with the range. This is the anti-tip device and must be installed with the unit. Refer to “Anti-tip Device Installation” section.

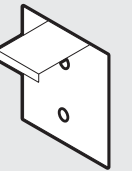

Some stainless steel parts may have a plastic protective wrap which must be peeled off. The interior should be washed thoroughly with hot, soapy water to remove film residues and any dust or debris before being used, then rinsed and wiped dry. Solutions stronger than soap and water are rarely needed.

Installation

⚠ CAUTION

To avoid risk of personal injury or product damages, **DO NOT** use the handle or oven door to lift the oven. Remove door before installation to ensure that it is not used to lift the unit. **DO NOT** lift or carry the door by the handle.

Removing the door must be done by your dealer, or a qualified licensed plumber.

Door Removal

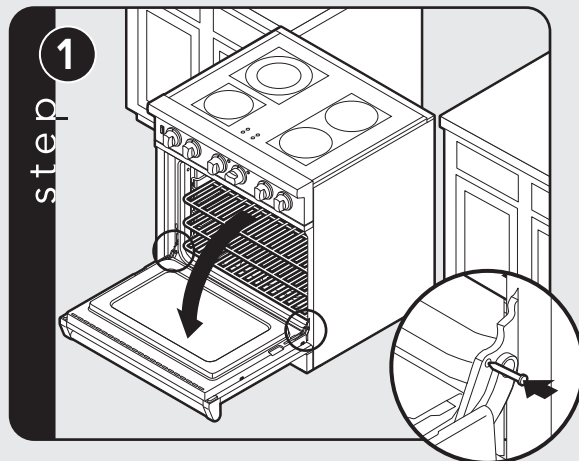

Open door completely. Place pins, supplied with unit, in pin hole. For personal safety, **ONLY** use pins supplied with the unit.

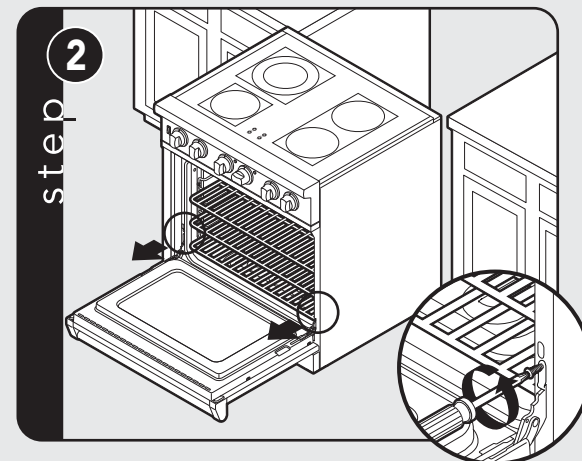

Remove hinge trim screws. Take off hinge trim. Identify right and left hinge for future re-installation.

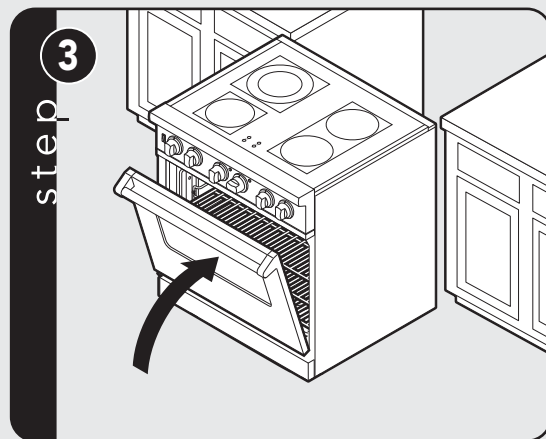

Close until pins stop door.

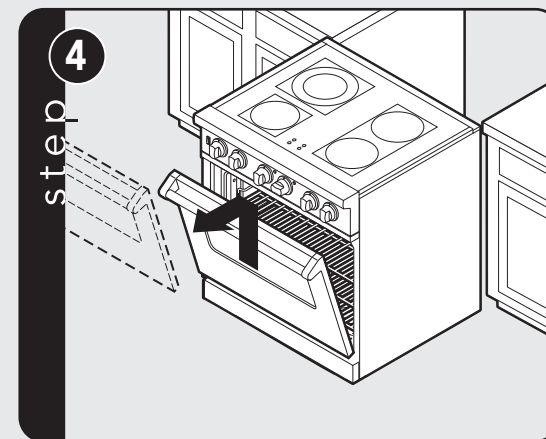

Lift door up and out.

Leg Installation

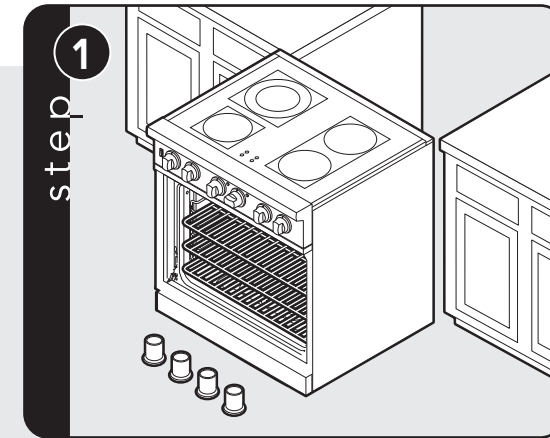

Legs are packed in styrofoam top pack.

Note: Legs should be installed near to where appliance is to be used, as they are not secure for long transit.

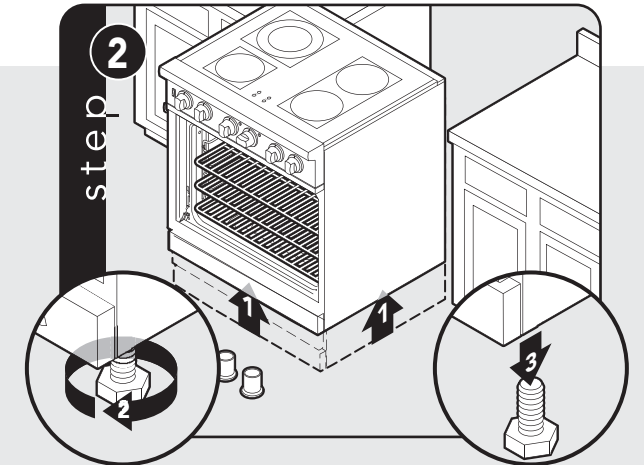

Note: It is strongly recommended that a pallet or lift jack be used rather than tilting. Raise unit about a foot. Unscrew temporary legs from couplings.

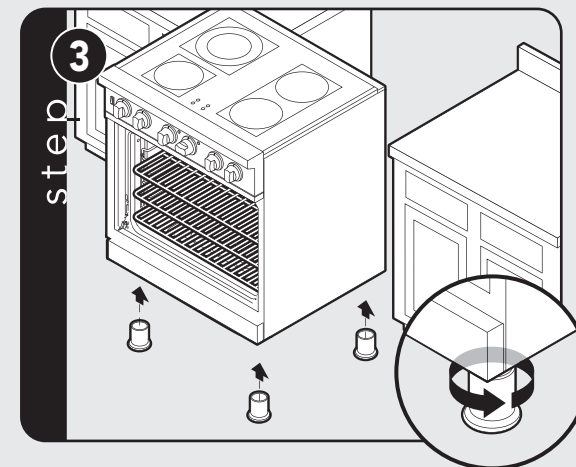

Screw legs into couplings on all four corners.

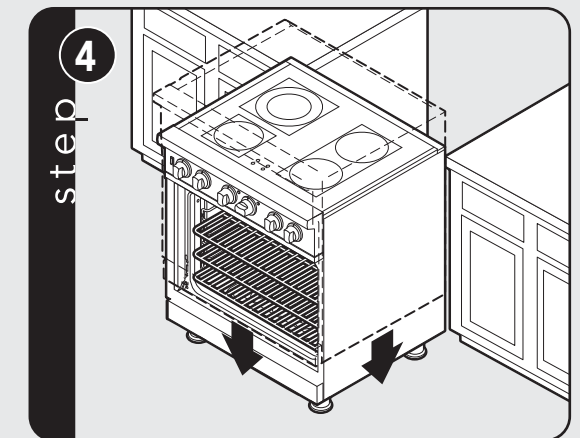

Lower range gently to keep any undue strain from legs and internal mounting hardware.

Electrical Connection (3-wire)

Note: If you have a 4-wire connection, see following section for 4-wire connection instructions.

⚠ WARNING



Electrical shock hazard.

To avoid risk of electrical shock, personal injury or death; grounding product to the frame of the unit may or may not be permitted through your local codes. If ground to the frame is not permitted then a 4 conductor power cord must be used.

⚠ WARNING



Electrical shock hazard.

To avoid risk of electrical shock, personal injury or death; verify your appliance has been properly grounded in accordance with local codes or in absence of codes, with the National Electrical Code (NEC). ANSI/NFPA 70-latest edition.

See Electrical Requirements information.

Where local codes do not permit grounding through neutral, use a 4-wire power supply cord. The cord or conduit must be secured to the range with the strain relief bracket.

The electrical connection is made at the terminal block, which is located behind the access door on the back of the range.

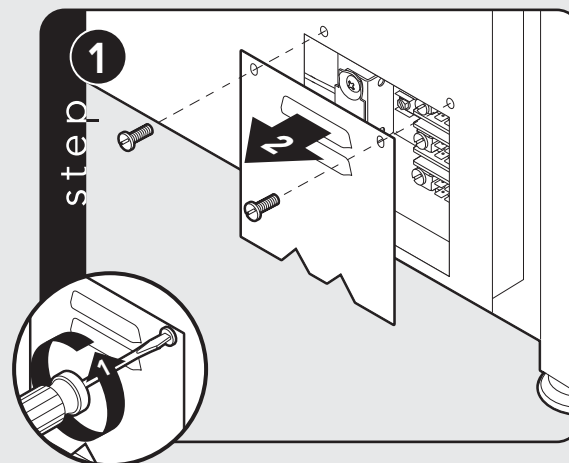

Remove access door.

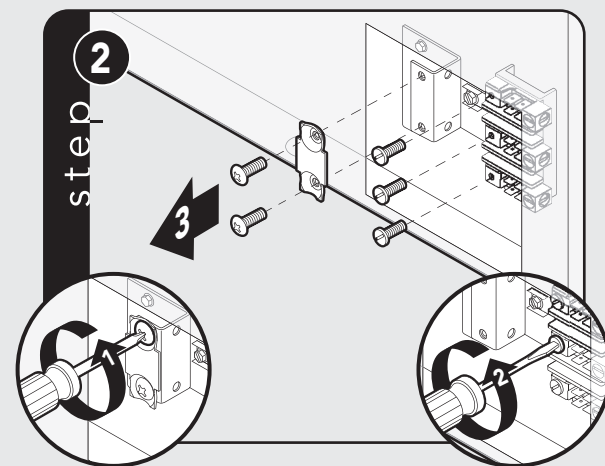

Remove supply cord strain relief bracket and three supply cord mounting screws on terminal block.

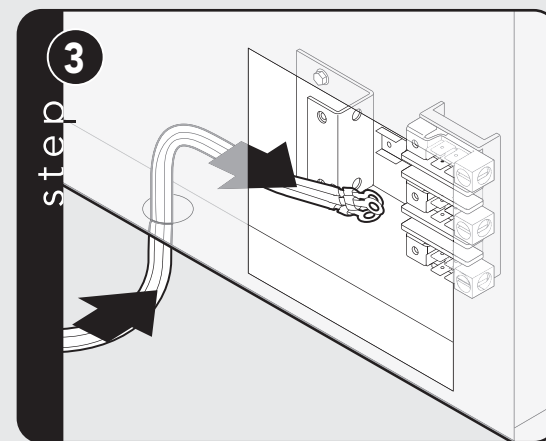

Feed supply cord up through hole in bottom of range back.

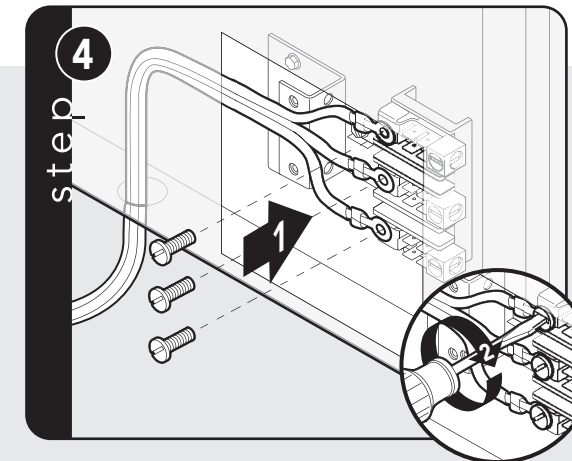

Attach line #1 (black) and line #2 (red) leads to outside terminal. Attach neutral wire (white) to center terminal on the terminal block.

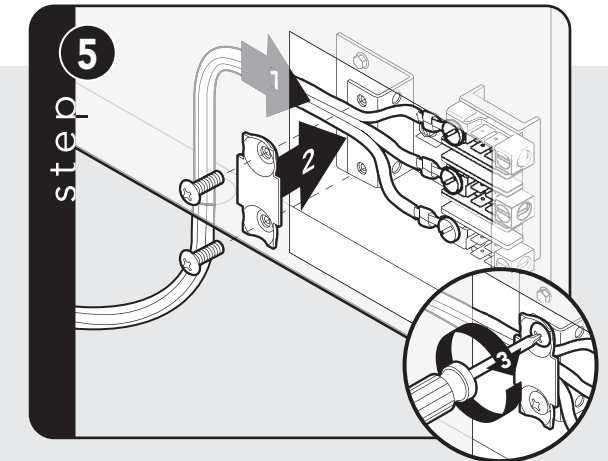

Push supply cord toward terminal block to relieve strain, reattach supply cord strain relief bracket over supply cord.

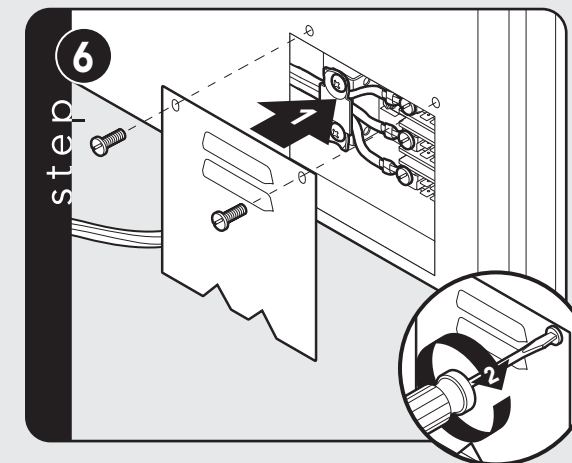

Reattach access door.

Electrical Connection (4-wire)

⚠ WARNING

Electrical shock hazard.
To avoid risk of electrical shock, personal injury or death; grounding product to the frame of the unit may or may not be permitted through your local codes. If ground to the frame is not permitted then a 4 conductor power cord must be used.



⚠ WARNING

Electrical shock hazard.
To avoid risk of electrical shock, personal injury or death; verify your appliance has been properly grounded in accordance with local codes or in absence of codes, with the National Electrical Code (NEC). ANSI/NFPA 70-latest edition.



See Electrical Requirements information.

Where local codes do not permit grounding through neutral, use a 4-wire power supply cord. The cord or conduit must be secured to the range with the strain relief bracket.

The electrical connection is made at the terminal block, which is located behind the access door on the back of the range.

step 1

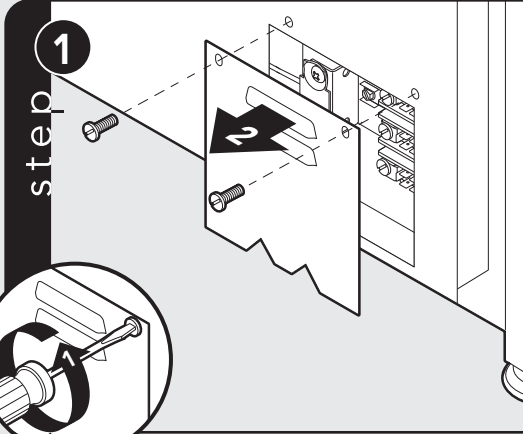

Remove access door.

step 2

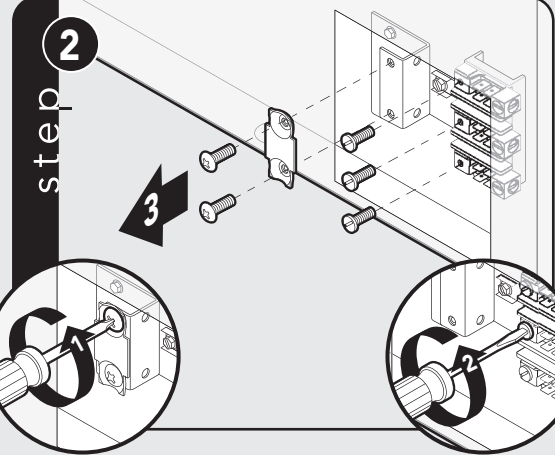

Remove supply cord strain relief bracket and three supply cord mounting screws on the terminal block.

step 3

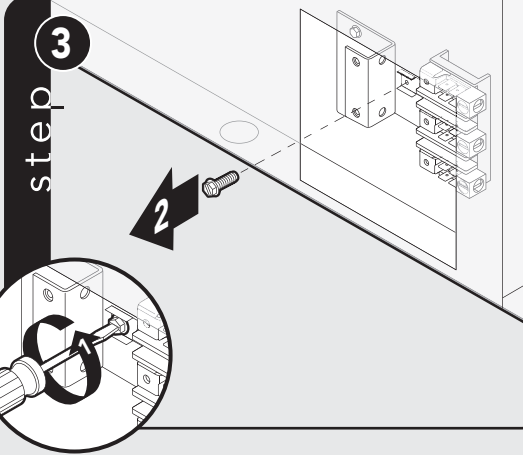

Remove grounding screw. Cut-off and discard ground strap.

step 4

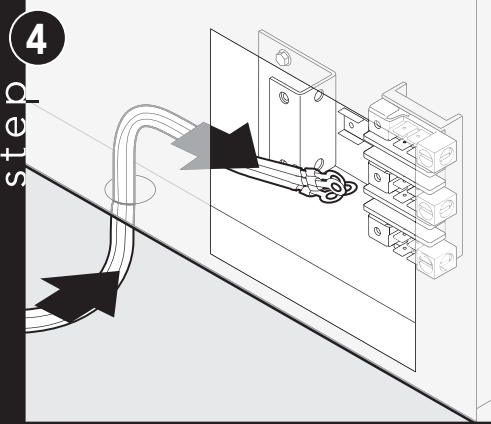

Feed supply cord up through hole in bottom of range back.

step 5

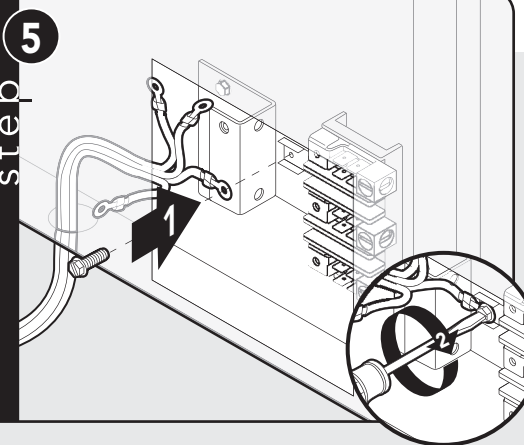

Attach ground wire (green) with ground screw that was removed.

step 6

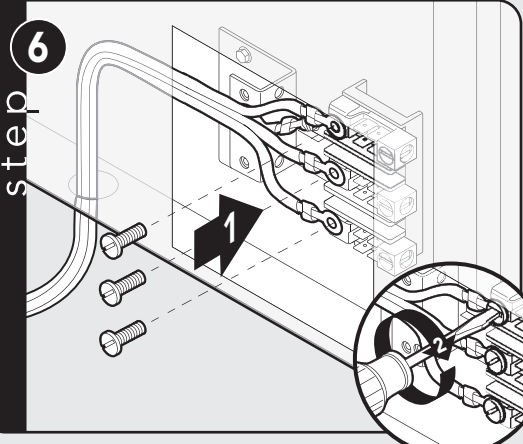

Attach line #1 (black) and line #2 (red) leads to outside terminal. Attach neutral wire (white) to center terminal on terminal block.

step 7

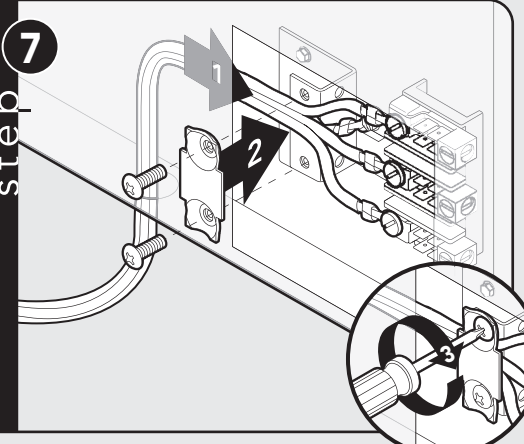

Push supply cord toward terminal block to relieve strain, reattach supply cord strain relief bracket over supply cord.

step 8

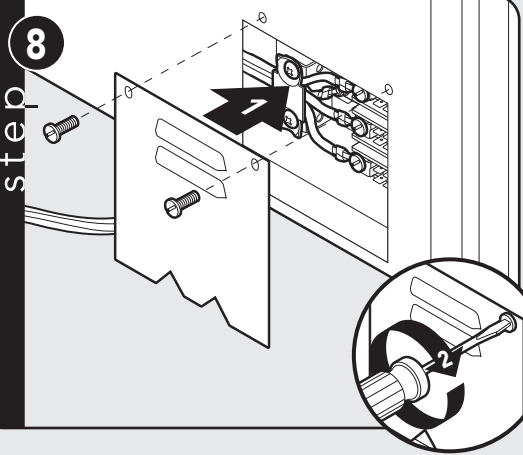

Reattach access door.

Leveling/Adjustments/Alignment

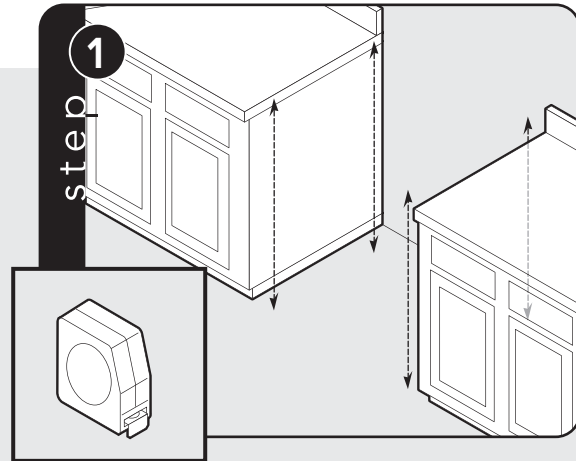

Measure the four corners in cutout area to verify if flooring is level.

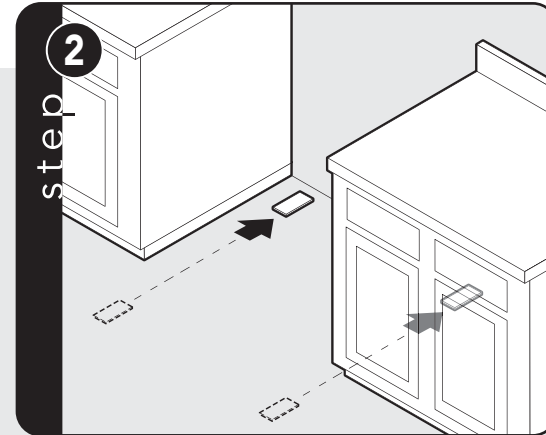

For uneven or sloped floors, level unit with metal shims only, as the adjustment required may exceed the thread available in the leg.

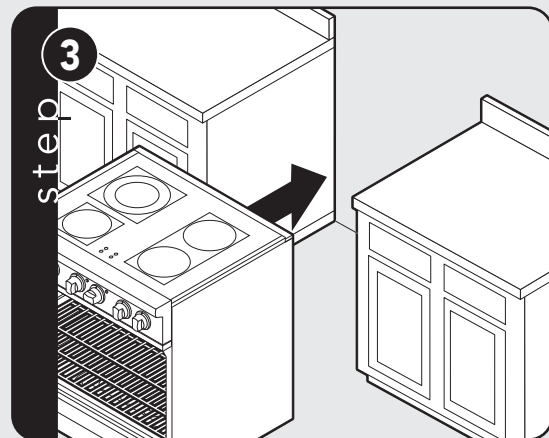

Move unit into opening.

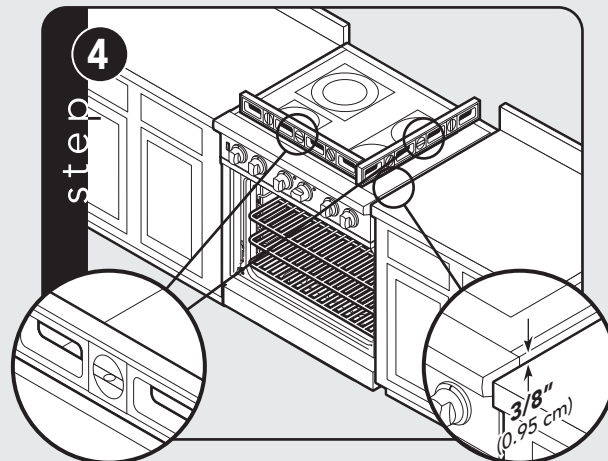

Check that unit is level side to side and front to back. Side trim of the high corner must be $\frac{3}{8}$ " (0.95 cm) above countertop.

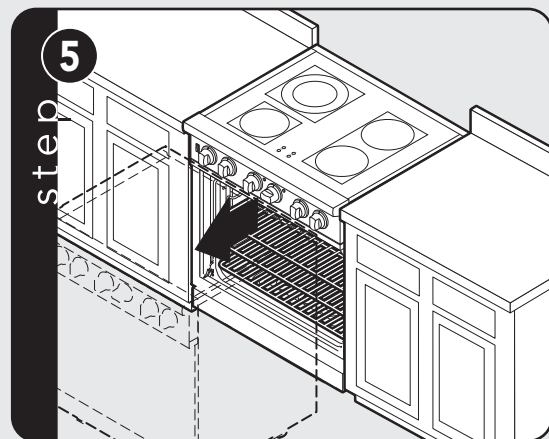

If leveling is required, move unit out of opening.

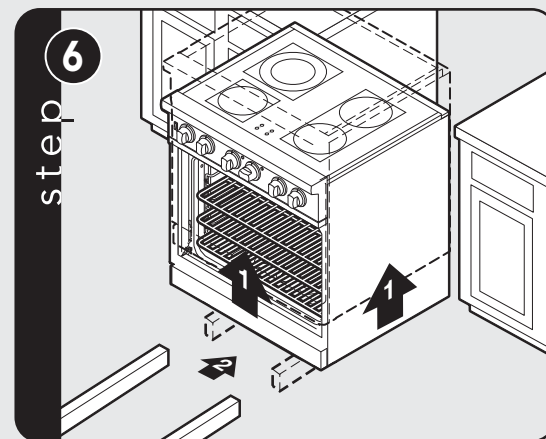

Lift unit and prop on wood blocks.

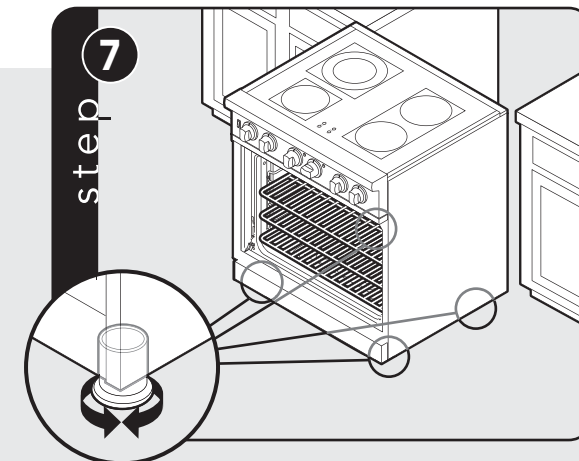

Set the high corner of range so that the top of side trim is $\frac{3}{8}$ " (0.95 cm) above countertop. Level range to high corner.

Anti-tip Device Installation

⚠ WARNING



Tipping hazard.

To reduce the risk of the appliance tipping, it must be secured by a properly installed anti-tip bracket(s). To make sure the bracket has been installed properly, look behind the range with a flashlight to verify proper installation engaged in the rear top left corner of the range.

- THIS RANGE CAN TIP.
- INJURIES TO PERSONS CAN RESULT.
- INSTALL ANTI-TIP DEVICE PACKED WITH RANGE.
- SEE INSTALLATION INSTRUCTIONS.

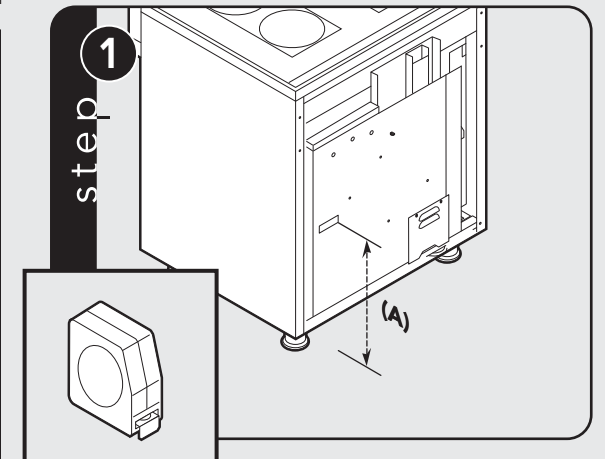

Measure from floor to bottom of the anti-tip opening located on the back of range. This will be measurement (A).

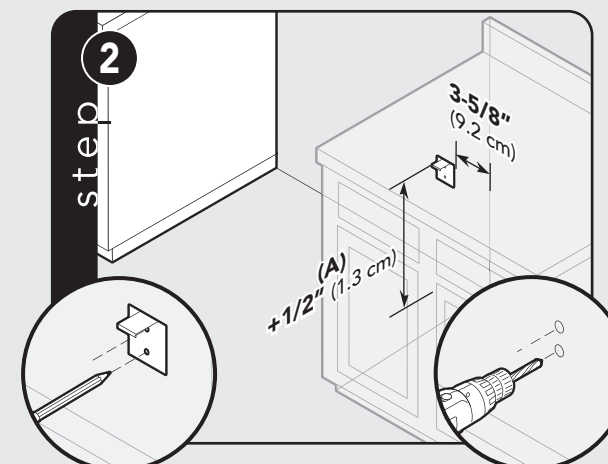

Locate anti-tip bracket on rear wall with the top left corner at measurement (A) plus $\frac{1}{2}$ " (1.3 cm) from the floor and $3\frac{5}{8}$ " (9.2 cm) from where the right side of range (facing range) is to be located.

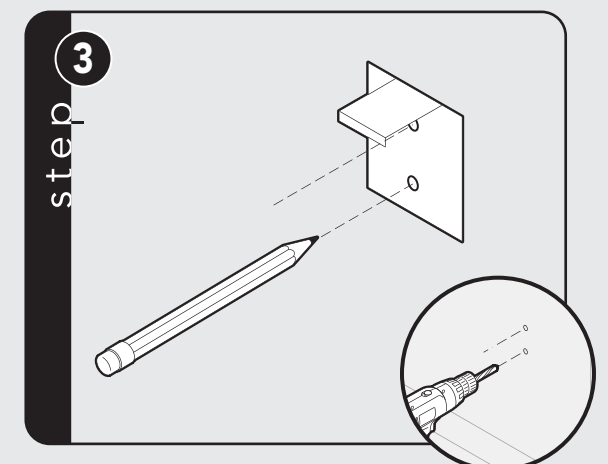

Mark and drill holes where bracket will be located.

Anti-tip Device Installation (cont.)

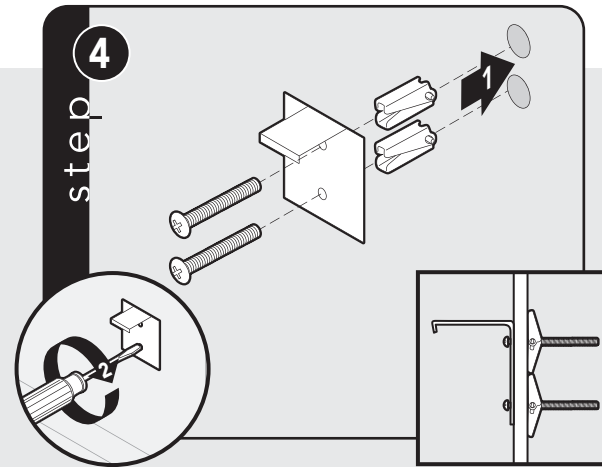

Attach bracket with mounting hardware provided.

Final Installation

Note: Refer to range electrical requirements section for proper installation information.

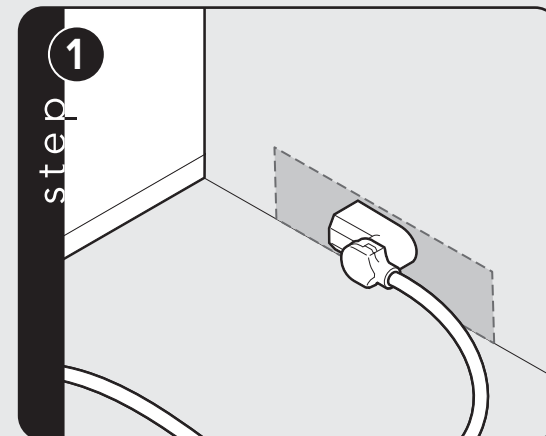

Connect electrical in shaded area. See the "Electrical Requirements" section for more information.

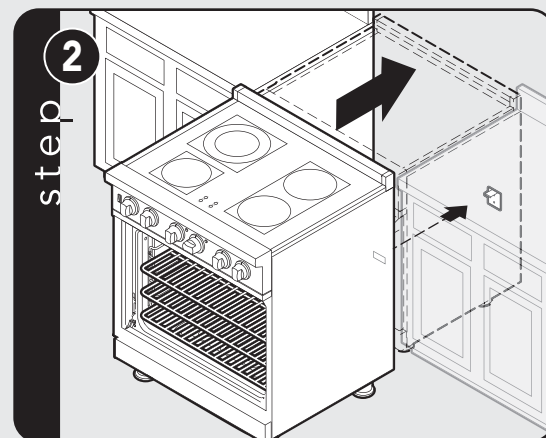

Slide range into place. Be sure anti-tip bracket slides into the anti-tip opening.

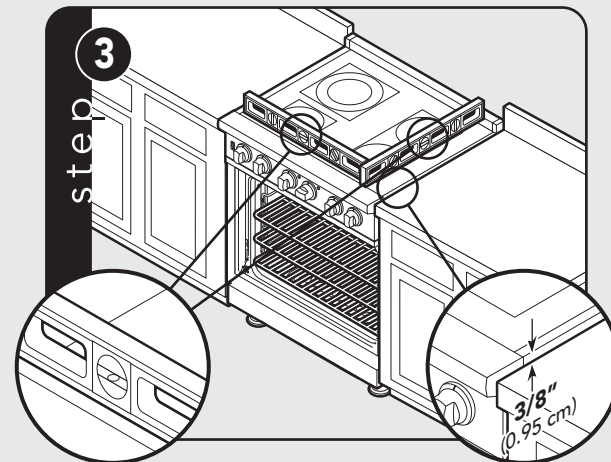

Check that unit is level side to side and front to back. The side trim must be 3/8" (0.95 cm) above countertop. If unit is not level repeat steps 5-7 of "Leveling/Adjustments/Alignment" section.

Door Replacement and Adjustment

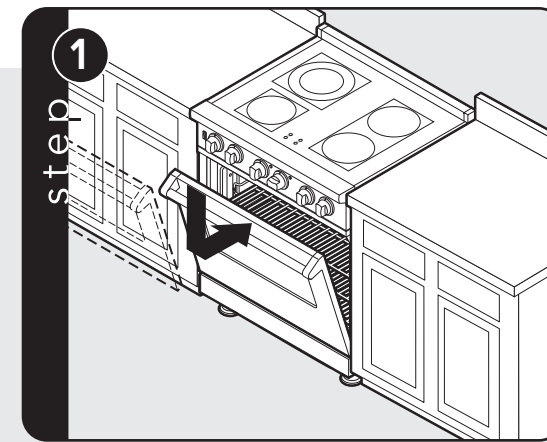

Reattach door to range.

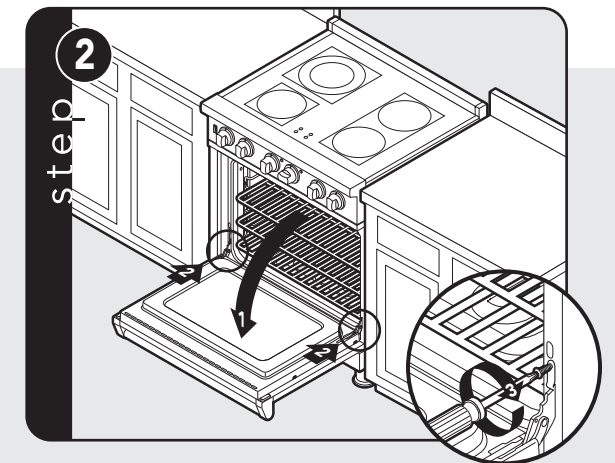

Open door completely. Reattach hinge trim.

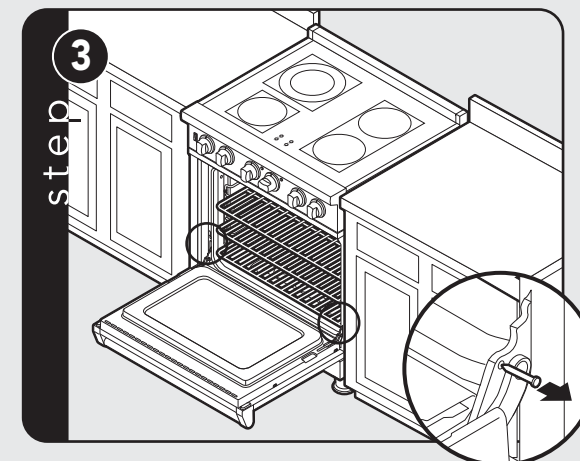

Remove pins from hole in hinges.

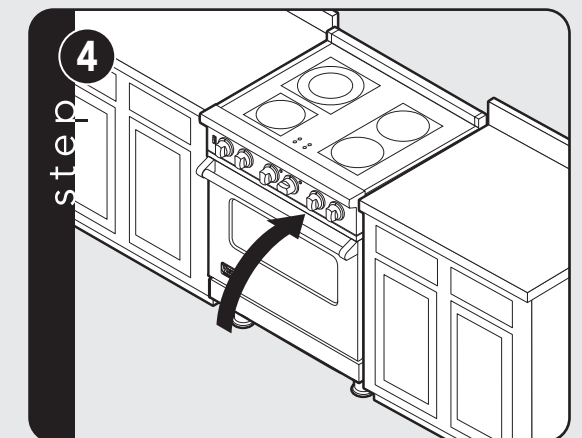

Close door.

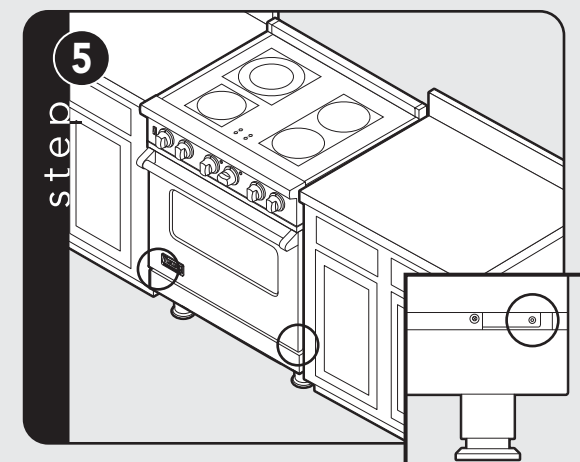

If the door needs to be adjusted, loosen hinge trim screws (see step 2). Adjust the screws located between the door and kickplate using a 5/32" hex head allen wrench. After adjustment, tighten hinge trim screws.

Final Preparation

- All stainless steel body parts should be wiped with hot, soapy water and with a liquid cleaner designed for this material. If buildup occurs, **DO NOT** use steel wool, abrasive cloths, cleansers, or powders! If it is necessary to scrape stainless steel

to remove encrusted materials, soak with hot, wet cloths to loosen the material, then use a wool or nylon scraper. **DO NOT** use a metal knife, spatula, or any other material tool to scrape stainless steel! Scratches are almost impossible to remove.

Performance Checklist

A qualified installer should carry out the following checks:

- Check top surface elements—glow red when turned on.
- Check hot surface indicator lights—glow red when corresponding element is on.
- Check oven bake function—bake element on full power, center and outside broil elements at partial power.
- Convection bake function—bake and broil elements the same with the convection fan on.
- Check TruConvec™ function—TruConvec element (behind convection fan cover) on and convection fan on.
- Check HI broil function—both broil elements at full power.
- Check LOW broil function—inner broil element only.
- Check convection broil function—both broil elements at full power with convection fan on.

- Check self-clean function—door will lock in approximately 30 seconds, the center and outside broil elements will turn on and the bake element will turn on at partial power. Check broil elements through window to make sure they are on, then abort self-clean cycle to unlock door.

⚠ NOTICE

When conducting performance test, **DO NOT** run self-clean cycle for more than 10 minutes with oven racks inside oven. This could cause them to discolor due to the high temperature required for self-cleaning.

Service & Registration

Only authorized replacement parts may be used in performing service on the appliance. All servicing should be referred to a qualified technician.

Contact Viking Range Corporation, 1-888-VIKING1 (845-4641), for the nearest service parts distributor in your area or write to:

**VIKING RANGE CORPORATION
PREFERRED SERVICE
1803 Hwy 82W
Greenwood, Mississippi 38930 USA**

Range – The serial number and model number for your appliance can be found by opening the door and looking under the control panel.

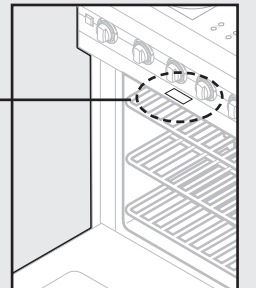

Record the following information indicated below. You will need it if service is ever required.

Model number _____

Serial number _____

Date of purchase _____

Date installed _____

Dealer's name _____

Address _____

These installation instructions should remain with the unit for future reference.