

Operation and assembly instructions

VK 411

Steam cooker



GAGGENAU

1. Important Notes	Page 3-4
For your safety	Page 3
Operating for the first time	Page 3
About use	Page 4
2. Features	Page 5
Features	Page 5
Special accessories	Page 5
3. Operation	Page 6-9
Operating principle	Page 6
Hooking in the special handle	Page 6
Switching on and off	Page 7
Holiday safeguard	Page 7
Draining cooking liquid from the cooking basin	Page 8
Visual signals	Page 9
4. Practical tips	Page 10
5. Settings table	Page 11-12
6. Cleaning and care	Page 13
7. Maintenance	Page 14
8. Installation	Page 15-20
Technical data	Page 15
Important notes on installation	Page 15
Preparing the cabinet	Page 16
Installing the control panel	Page 17
Installing the appliance	Page 18
Drain installation	Page 19-20

**Congratulations on buying your new
“Vario” appliance.**

Before switching your appliance on for the first time, we would like you to familiarize yourself with your new appliance. In this manual you will find important notes on safety and operation. These will serve to ensure your personal safety and the lasting value of your appliance.

You will find notes on Page 3 that you ought to observe before operating the appliance for the first time.

The chapters entitled “Features” and “Operation” tell you all about what your appliance can do and how you operate it.

The chapter entitled “Cleaning and Care” gives tips on how to keep your appliance looking good.

And now we wish you lots of fun cooking.

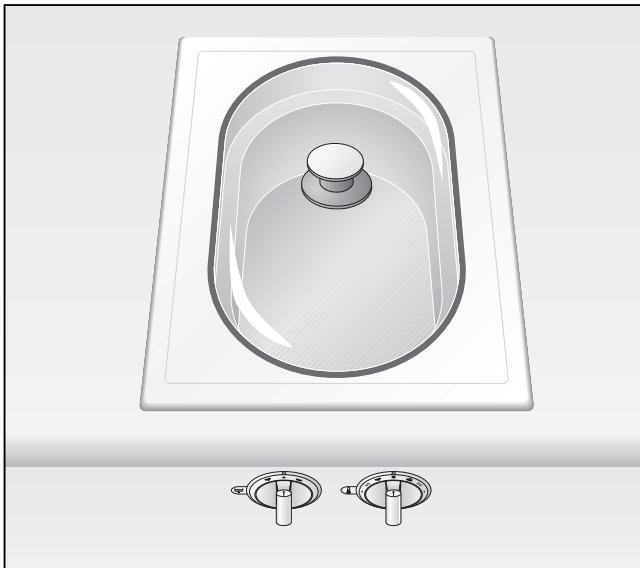

1. Important Notes

For your safety

Do not operate the appliance if it is damaged.

The appliance must only be connected by an authorised specialist, paying attention to the relevant regulations of the power supply companies and the regional construction regulations.

Observe the assembly instructions!

The appliance could be damaged if connected wrongly!

When connecting electrical appliances in the proximity of the steam cooker, make sure that connecting cables do not come into contact with hot cooking surfaces.

Only operate the appliance under supervision.

Caution: Fire Risk! Do not store any combustible objects in your appliance. When operating the appliance, only leave the required parts inside the cooking basin.

Caution: the appliance heats up during operation. Keep children away.

To avoid jeopardising the electrical safety of the appliance, do not use high-pressure or steam jet cleaning devices.

Isolate the appliance from the mains during every maintenance operation. To do this, remove the mains plug or switch off the corresponding fuse.

Repairs must be carried out by authorised specialists, thus ensuring electrical safety.

As the user, you are responsible for maintenance and proper use in the household. No warranty claims can be lodged for any damage resulting from failure to observe these instructions.

Note:

if you have fitted the appliance cover VD 400-000 (special accessory) on the appliance, it must not be closed until the appliance has cooled down completely. Do not operate the appliance with the cover closed! Heat development may damage the appliance and the cover. Do not use the appliance cover as a surface for placing objects or for keeping things warm.

Subject to technical change without notice.

Operating for the first time

Remove the packaging from the appliance and dispose of it according to local regulations. Be careful to remove all accessories from the packaging. Keep packaging elements and plastic bags away from children.

Check the appliance for transport damage before installing it.

The appliance must be installed and connected by an authorised specialist before operation. Before operating the appliance for the first time, make sure that the mains connection is in proper working order.

The serial number of the appliance can be found on the quality control slip which is included with these instructions. This quality control slip should be kept, for guarantee reasons, together with your operating and assembly instructions.

Read through these instructions attentively before operating your appliance for the first time.

Thoroughly clean the appliance and accessories before using them for the first time. This will eliminate any 'newness' smells and soiling (see chapter "Operation").

About use

The boiling point of water depends on your location in relation to sea level. When operating for the first time, the appliance calibrates itself automatically. During calibration you might notice more steam than usual. Your appliance can be used as normal to prepare food while it is calibrating.

The appliance is intended solely for household use and must not be put to any other uses.

Use the appliance to prepare meals only. Do not use the appliance to heat up the room in which it is installed.

The appliance is suitable for use with water or cooking liquid only. Do not use the appliance for deep frying.

The appliance must not be operated empty. If the appliance is switched on empty, the temperature control will switch off the appliance automatically. Turn the "Temperature" control knob to the OFF position. Wait until the appliance has cooled down.

Fill the cooking basin with liquid at a minimum to the lower marking and not more than to the boil-over rim.

Only use the intended cooking inserts.

Only add salt and stock cubes to the hot water. The cooking basin is to a great extent corrosion proof, however, in certain cases, for example salt, can cause damage to the material.

Always place the glass lid firmly on the appliance while in use!

Caution! Risk of burns! Use the special handle to remove and insert the cooking inserts.

Make sure that the steam outlet opening is not covered up during operation.

Switch off the appliance after use. Clean the appliance once it has cooled down after every use.

Caution! When hot, the glass cover must not be placed on a wet and cold worktop or cooled under cold running water. It might otherwise crack. Replace the glass cover immediately if it is damaged. If glass splinters should enter into the cooking basin as the result of a damaged glass cover, bear in mind that the foodstuffs prepared in it are no longer suitable for consumption.

Do not place any items on the glass lid.

We recommend you install your appliance with a permanent drain connection. Use extreme caution when draining the appliance without a permanent drain connection. **Risk of scalding!** Use a temperature-resistant container with an adequate capacity (e.g. a 10 l bucket).

The door(s) of the base cabinet must be locked if you do not have a permanent drain connection and there are small children in your household. This reduces the risk of burns.

If you have a permanent water drain connection, pay attention to the applicable regulations.

Built-in overheating protection prevents overheating of the appliance and of surrounding kitchen furniture.

In the event of malfunction, first check your household fuses. If the power supply is in proper working order, but the appliance is still not functioning, please inform your specialist dealer or your nearest Gaggenau after-sales service.

2. Features

Features

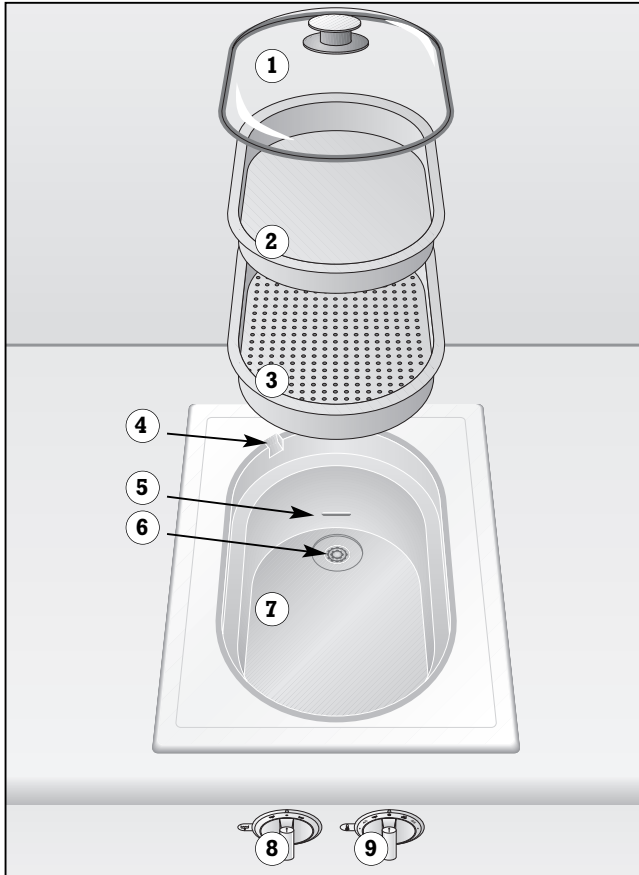

- 1 Glass lid
- 2 Unperforated cooking insert (GE 020-010)
- 3 Perforated cooking insert (GE 020-020)
- 4 Steam outlet opening
- 5 Minimum level marker
- 6 Strainer
- 7 Cooking basin
- 8 Control knob to drain cooking basin
- 9 Temperature control knob

Special accessories

You can order the following special accessories:

- GE 020-010** Unperforated cooking insert
- GE 020-020** Perforated cooking insert
- FK 023-000** Noodle basket
- VV 400-000** Connecting trim
- VZ 400-000** Connecting trim with timer
- VD 400-000** Appliance cover
- AG 050-000** Drain installation set for permanent connection
- AG 060-000** Drain installation set for draining water into a receptacle

3. Operation

Tips when using for the first time

Thoroughly clean the appliance and accessories with mild soap detergent before using them for the first time. This will eliminate any 'newness' smells and soiling. Fill the cooking basin up to the lower marking with clean water. Replace the glass lid and operate the appliance at the steam cooking level for 30 minutes. During this time the appliance calibrates itself automatically. During calibration you might notice more steam than usual. Drain the water.

The boiling point of water depends on your location in relation to sea level. When operating for the first time, the appliance calibrates itself automatically to the correct setting.

Should you move to a different area, the appliance has to be re-calibrated. Fill the cooking basin up to the boil-over rim with water and replace the glass lid. Turn the "Temperature" control knob three times from the position 95 °C to the steam cooking level and finally leave it on the steam cooking level. The appliance then calibrates itself automatically. This will take about 10 minutes. Do not take off the glass lid during the calibration process.

Operating principle

In the steam cooker you can cook, steam cook and blanch.

Steam cooking consists of cooking in a steam flow. The temperature range is between 80 °C and 100 °C. The steam transmits the heat. Suitable foodstuffs are vegetables, potatoes, fish and yeast dumplings.

The steam seals the food that is being cooked and prevents a loss of nutrients in the foodstuffs.

Cooked food retains its shape, its colour and its typical aroma. Foodstuffs are not browned in the steam cooker.

The appliance offers you the possibility of steam cooking without pressure using one or two cooking inserts. When you use the perforated cooking insert, the steam is able to reach the food on all sides. This ensures uniform cooking even of large quantities of food.

You can also set the cooking liquid temperature in 5 °C stages between 45 and 95 °C. This precise adjustment of the water temperature allows you, for example, to melt chocolate icing, poach meat or boil pasta.

Hooking the handle into the cooking inserts

The cooking inserts can only be inserted in and removed from the steam cooker by using the included special handle. The special handle is not suitable for tipping over the cooking inserts, e.g. to pour out the contents.

Note: by using the special handle to remove or insert the cooking inserts, you will protect your hands against burns while cooking.

Proceed as follows:

- Slide the special handle into the recess provided for this purpose.
- Tilt back the handle and lift the cooking insert.



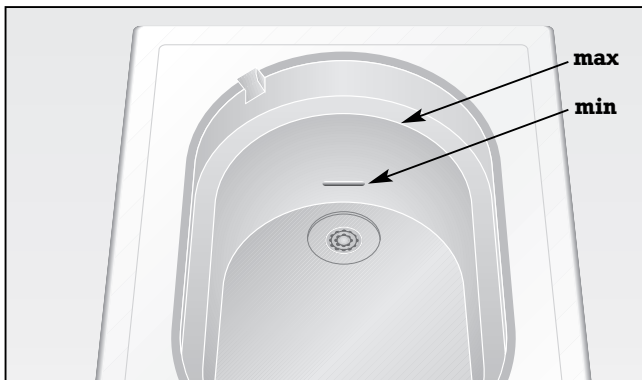

Important: Never operate the steam cooker without liquid.

Filling the cooking basin

Fill the cooking basin with water or another cooking liquid (between 1 - 6 litres, refer to the settings table). Do not fill the cooking basin with oil. Fill the cooking basin with liquid at a minimum to the lower marking and not more than to the boil-over rim.

Switching on

Press down the right control knob and turn it left or right to the required temperature or the steaming setting. The luminous disc behind the control knob flashes, as long as the appliance heats up. Insert the cooking inserts with the food when the appliance has heated up and the luminous disc lights constantly. Replace the glass lid.

We recommend to always pre-heat the steam cooker.

Switching off

Fully turn the right control knob to the OFF position.

Holiday safeguard (Automatic switch-off)

The appliance is set to automatically switch off 4 hours after the last operation. The luminous disc behind the right control knob flashes. Turn the control knob to 0. Now the steam cooker can be switched on again as normal.

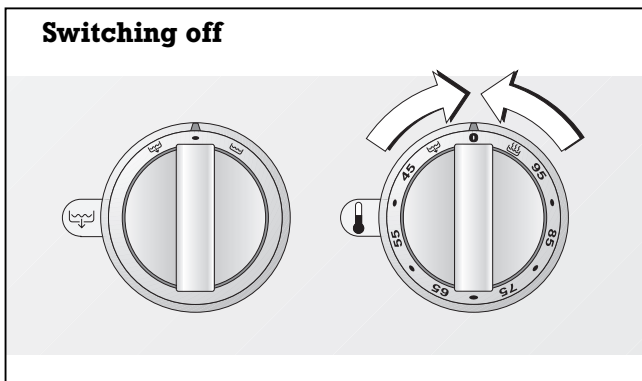
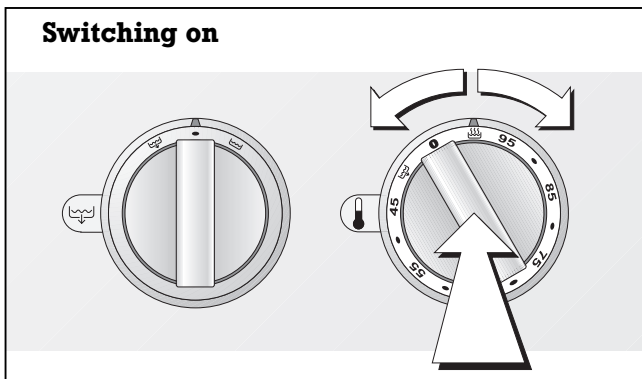

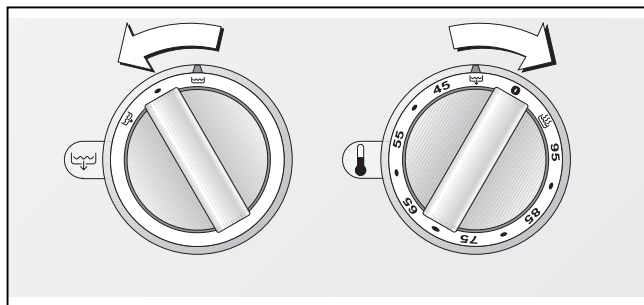
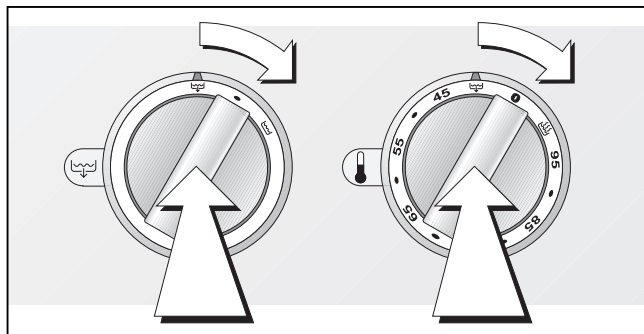

Note:

Allow the water or the cooking liquid to cool down before draining it: this avoids steaming in the base cabinet and scalding.

Pay attention to regular descaling if you live in a hard water area. Otherwise, discoloration of the cooking basin and heat build-ups may result.

















Draining the cooking liquid from the cooking basin

- Only if your steam cooker is not installed with a permanent drain connection:
place a heat resistant container (e.g. a 10 l bucket) under the drain valve of the additionally installed drain installation set AG 060-000.
- Turn the “Temperature” control knob to the right to the draining position . Turn the left control knob to the right to the draining position .
- A signal is sounded, the drain valve is opened. The luminous disc behind the left control knob flashes while the drain valve is open.

Closing the drain valve

- Turn the “Temperature” control knob to the right to the draining position .
- Turn the left control knob to the left to the closing position .
- The drain valve is closed. The luminous disc behind the left control knob goes off when the drain valve is closed.

Visual signals

Luminous disc behind the left control knob	Luminous disc behind the right control knob	Signification	Cause / Remedy
	 lights OFF		appliance is switched OFF
	 right control knob lights constantly	appliance is ON	normal use
	 flashing of right control knob	appliance is heating up	normal use
	 flashing of left control knob	drain valve is open	Close the drain valve after draining the cooking liquid. The appliance will not heat up while the drain valve is open.
	 fast flashing of right control knob	appliance was operated empty or overheating protection	Appliance was switched on without any cooking liquid or cooking liquid has evaporated. Fill basin at least to the minimal marker and let the appliance cool down.
	 fast flashing of right control knob	holiday safeguard	The appliance setting has not been changed for over 4 hours. Turn control knob to 0 and then switch on again if required.
	 fast flashing of right control knob	power cut	After a power cut, the appliance stays switched off for safety reasons. Turn control knob to 0 and then switch on again if required.
	 fast flashing of both control knobs alternately	faulty installation	Connecting cable between the appliance and the control panel is not plugged in. Check that cable is plugged in firmly.

4. Practical tips

Cooking in steam

- Fill the steam cooker to the bottom marking and pre-heat on the steam cooking level.
- Place the cooking insert with the food inside the appliance. When using two cooking inserts at the same time, place the perforated cooking insert first and then the unperforated above it.
- Fit the glass lid.
You can highlight the taste of meals by replacing the water with a liquid that matches the food (vegetable, fish or meat stock).

Keeping warm

- Fill the steam cooker to the bottom marking.
- Turn the "Temperature" control knob to 80-90°C and pre-heat.
- Place the cooking insert with the food inside it in the appliance.
- Fit the glass lid.
This is a gentle method to keep food warm over a prolonged period of time. This retains the flavour and prevents the food from drying out.

Regenerating

Meals that have already been prepared can be regenerated (reheated) in the steam cooker.

- Fill the steam cooker to the bottom marking and pre-heat on the steam cooking level.
- Place your prepared meal in the corresponding cooking insert and turn the "Temperature" control knob back to the required temperature (85-95°C).
Fit the glass lid.

Cooking

- Fill the cooking basin with water or another cooking liquid (no oil!) up to the boil-over rim.
- Turn the "Temperature" control knob to a temperature between 45 and 95°C and pre-heat.
- You are advised to fit the glass cover.
Use the noodle basket (accessory FK 023-000).

Cooking in boiling water

- Fill the cooking basin with water up to the boil-over rim and pre-heat on the steam cooking level.
- Do not fit the glass lid. Use the noodle basket (accessory FK 023-000).

Extracting juice

- Fill the steam cooker to the bottom marking and pre-heat on the steam cooking level.
- Place fruit in the perforated insert.
- Place the unperforated insert in the appliance and then the perforated insert above it.
- Steam until no more juice is extracted.

Sterilising

- Fill the steam cooker to the bottom marking.
- Place jars in the perforated insert in such a way that they do not touch each other.
- Turn the "Temperature" control knob to the steam cooking level setting.
- Switch off the appliance as soon as bubbles start to rise in the jar.
- Do not remove the jars from the appliance until they have cooled down fully.

Blanching

- Fill the steam cooker to the bottom marking and pre-heat on the steam cooking level.
- Place the vegetables in the unperforated insert.
- After 1-2 minutes, place the vegetables in icy water to cool them down fast. Allow the vegetables to fully drip dry.

5. Settings table

Steaming / Cooking

Setting: steam cooking

Foodstuff	Water quantity (l)	Cooking insert selection	Food quantity	Preparation	Cooking times* (minutes)
Meat					
Meatballs	1	perforated	500 g		15 - 20
Fillet of beef	1	unperforated	400 g	place herbs, e.g. 1/2 teasp. thyme in the cooking basin	15 - 20
Chicken breast, filled	1	unperforated Base buttered	500 g		20 - 25
Turkey breast	1	unperforated Base buttered	300 g	over vegetable stock	15
Smoked pork	1	unperforated	1 kg		60
Boiled beef	1	unperforated	1 kg	with soup vegetables	85 - 90
Fish					
Salmon fillet	1	perforated	600 g		10
Truite bleu	1	perforated	2 trouts	vegetable stock with vinegar	8 - 10
Trout in stock	1	unperforated	2 pieces		10 - 15
Cod cutlets steamed in wine	1	unperforated	2 cod cutlets	possibly in a vegetable bed over water and wine	20
Ocean perch fillet	1	unperforated	3 fillets		10 - 12
Pike fillet	1	unperforated	1 kg + 0,5 l water and ingredients		15 - 20
Mussels	1	perforated, unperforated		in the perforated insert with juice	10 - 15
Vegetables					
Cauliflower	1	perforated	1 head	in roses	20 - 30
Cauliflower and carrots	1	unperforated perforated	1 kg 1 kg	in roses sliced	35 - 40
Broccoli	1	perforated	1 head	in roses	8 - 12
Green beans	1	perforated	800 - 1000 g		20 - 25
Kohlrabi	1	perforated	800 g	sliced	30 - 35
Carrots	1	perforated	1 kg	sliced	20 - 25
Jacket potatoes	1	perforated	1 kg		35 - 40
Boiled potatoes	1	perforated	1 kg	halve	20 - 25
Boiled potatoes and cauliflower	1	perforated unperforated	1 kg 1 kg	halve in roses	25 - 30
Asparagus spears	1	perforated, unperfor.	2 kg	whole	25 - 40
Courgettes, aubergine	1	unperforated	500 g	sliced	5 - 8
Spinach	1	unperforated	250 g		4
Fennel	1	perforated	4 pieces	whole	30 - 40

Foodstuff	Water quantity (l)	Cooking insert selection	Food quantity	Preparation	Cooking times* (minutes)
Side dishes					
Rice, untreated	1	unperforated	250 g 0,5 l water		40 - 45
Parboiled-rice	1	unperforated	250 g 0,5 l water		20
Pasta	4	Noodle basket	500 g		according to manufacturer's specifications
Swabian noodles, fresh pasta	4	without	500 g		2 - 5
Cooked-egg garnish	1	unperforated base buttered	1 litre		10 - 15
Desserts					
Pudding in bain-marie tin	1	perforated	quantity for 1,5 litre tin		according to recipe
Stewed fruit	1	unperforated	1 kg, 1/4 l water		10 - 20
Yeast dumplings	1	unperforated	8 dumplings, 1/8 l milk, butter and sugar		15 - 20
Rice pudding	1	unperforated	250 g, 0,8 l milk		25 - 30

* Note: the cooking times specified here are rough guide values only.

You are advised to always preheat the steam cooker. If the appliance is not preheated, cooking times are prolonged by around 5 minutes.

When using two cooking inserts at the same time, put the perforated cooking insert into the cooking basin first and then the unperforated cooking insert above it.

Cooking table

Simmering

Setting: temperature level

Foodstuff	Water-quantity (l)	Cooking insert selection	Food quantity	Temperature	Cooking times* (minutes)
Sausages	4	without	4 - 8 pairs	75 - 85 °C	10 - 20
Meat dumplings	4 (e.g. stock)	without	depending on the size	90 - 95 °C	20 - 30
Dumplings	4	without	4 - 6	90 - 95 °C	20 - 30
Mulled wine	-	without	min. 1 litre	80 - 90 °C	-

* Note: the cooking times specified here are rough guide values only.

6. Cleaning and care

Note: to avoid jeopardising the electrical safety of the appliance, do not use high-pressure or steam jet cleaning devices – risk of short circuits!

Caution, risk of burns! Before cleaning, please wait until the appliance has cooled to hand-warm.

Do not use any abrasive and caustic cleaning agents (scouring or nitro polishing agents). Do not use any cleaning agents containing chloride (for example bleach), these can cause corrosion damage to the appliance.

Use plastic pot cleaners or a soft dishwashing brush and normal detergent. Do not use any abrasive sponges either.

Clean the appliance and accessories thoroughly before using them for the first time. Fill the cooking basin up to the foaming edge and operate the appliance at the steam cooking level for 30 minutes to remove any 'newness' smells. Drain the water.

Clean the **cooking basin** with a mild detergent solution.

The cooking basin should not be treated with stainless steel care agents because, in most cases, these are not neutral as far as food-stuffs are concerned.

You can clean **the glass cover and the cooking inserts** in the dishwasher.

Cleaning the control knobs

Wipe with a damp cloth. Cloth should not be too wet, as moisture could penetrate behind the control knob.

Clean the appliance after every use:

- Empty and clean the steam cooker with mild soap solution.
- Soiling, salt and limescale deposits can cause corrosion.
- Clean the cooking inserts in the dishwasher or with mild soap solution. The handle for the cooking inserts must only be cleaned by hand.
- Rub the cooking basin dry with a cloth. The glass lid should not be fitted while the cooking basin is still moist.
- If a white coating should form in the cooking basin owing to very hard water, wipe out the basin with a water and vinegar mixture or a descaling agent that is not harmful to foodstuffs and then rinse it well with clear water.
- Polish the cooking basin with a soft cloth and a drop of cooking oil.

After cleaning and drying, you can store the cleaned cooking inserts and the handle in the cooking tub. Turn over the glass cover to make sure that the appliance cover (special accessory) will lie properly on the recess.

7. Maintenance

The appliance must always be disconnected from the mains when being repaired.

If the appliance does not function correctly, check the household fuses first.

If the power supply is functioning correctly, but your appliance still does not work, please contact your dealer or your local Gaggenau customer service agency. Specify the appliance type. The serial number and type of the appliance can be found on the quality control slip which is included with these instructions.

Repairs may only be carried out by authorised technicians, in order to guarantee the safety of the appliance.

Unauthorised tampering with the appliance will invalidate any warranty claims.

8. Installation

Technical data

Total connected load:
220-240 V / 2 000 W

Important notes on installation

This appliance can be combined with all Gaggenau Vario 400 Series appliances.

Note: do not install the appliance directly next to a deep fryer!

This appliance may be installed in kitchen combinations made of wood or similar combustible materials without taking additional safety measures. The built-in furniture and worktop where the appliance is installed must be heat resistant up to temperatures of 200°F/90°C.

The appliance must only be connected by an authorised specialist, paying attention to the relevant regulations of the power supply companies and the regional construction regulations.

The mains connecting cable must at least correspond to type H 05 VV-F (3 x 1,5 mm²). Pay attention to the data on the rating plate. The appliance must be properly grounded.

When connecting electrical appliances in the proximity of cooking surfaces, make sure that connecting cables do not come into contact with hot cooking surfaces.

The installation technician is responsible for the correct functioning of the appliance at the place of installation. He must instruct the user on how to disconnect the appliance from electricity in an emergency.

After unpacking, check the appliance for any transportation damage and report this immediately to the transportation company.

There must be a gap of at least 40 mm at the side between the appliance and any walls or furnishings.

The minimum distance from the trough base to the nearest heat-sensitive parts is 10 mm.

An extractor hood must be installed if suspended cupboards are installed over the steam cooker because the steam might otherwise damage the furniture.

If all poles of the appliances cannot be isolated from the mains by removing an accessible plug, an isolating device with a contact gap of at least 3 mm must be installed (e.g. domestic fuse).

No warranty claims can be lodged for any damage resulting from failure to observe these instructions. Pay attention to the “Important notes” on page 3 and 4.

Subject to technical change without notice.

Preparing the cabinet

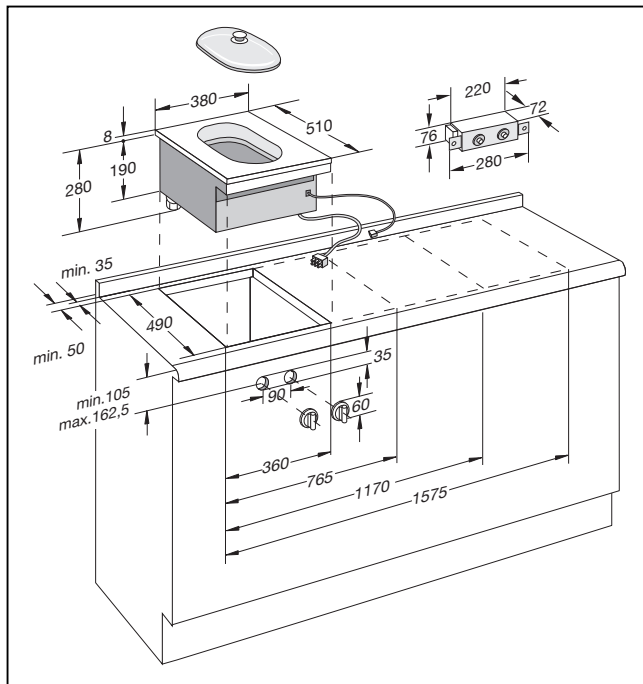

- Cut out the recess for the hob in your worktop. Proceed as indicated on the installation sketch. The installation sketch contains the measurements of the space required for the trim between the appliances. Several appliances can also be installed in individual recesses, as long as a minimum clearance of 50 mm is kept to between the appliances.
- As shown in the installation sketch, drill the $\varnothing 35$ mm holes to secure the control knobs in the cabinet front.
- If the cabinet front is thicker than 26 mm, the front must be routed from the back to max. 26 mm on an area of 80 x 310 mm.

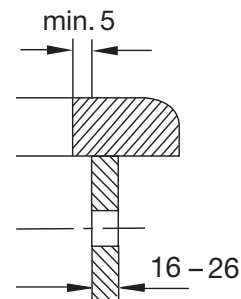
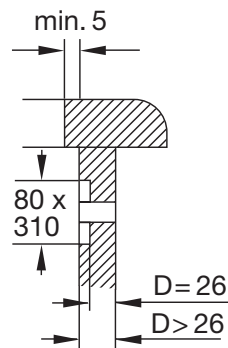

Installing the control panel

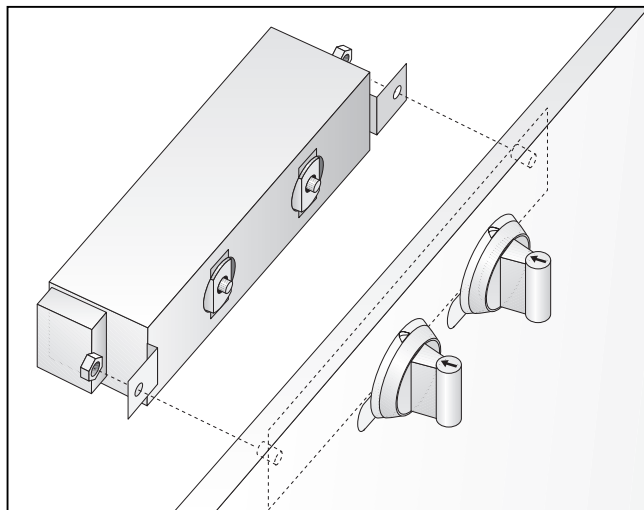
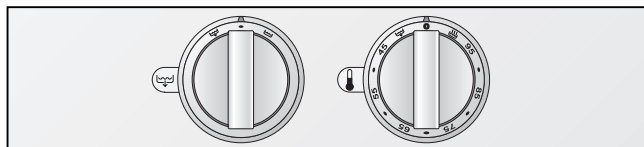
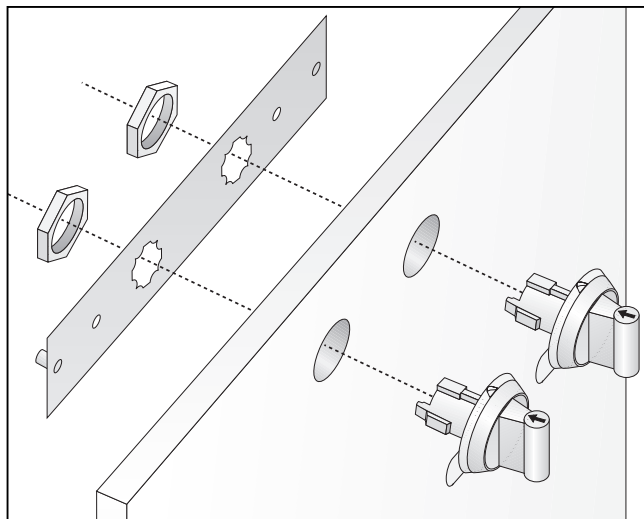

Note:

only install control panel with appliance of the corresponding type.

Before connecting the appliance, make sure the electricity is switched off at fuse point!

- Before installation, remove all styrofoam packaging from the control knobs and peel off the protective film behind the luminous discs.
- Open the lid of the connecting terminal on the control panel. Secure the mains connecting lead as shown in the connection diagram. Secure the connecting lead with the pull relief. The mains connecting cable must at least correspond to the type H 05 VV-F (3 x 1,5 mm²). Close the lid of the connecting terminal.
- Hold the support plate from the rear against the cabinet front, insert control knobs into the holes, secure from the rear with the nuts. Take care to install control knobs in the correct order: left control knob to drain cooking basin, right control knob for temperature selection.
- Secure the control panel with the included nuts onto the support plate.

Installing the appliance

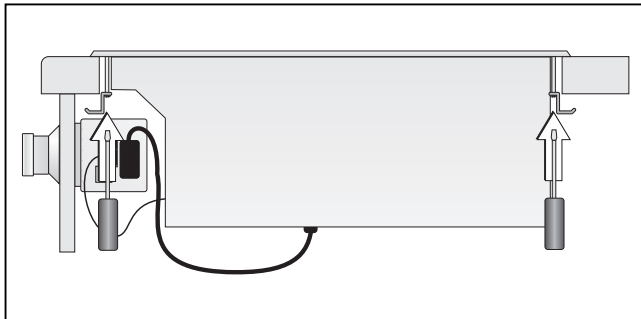
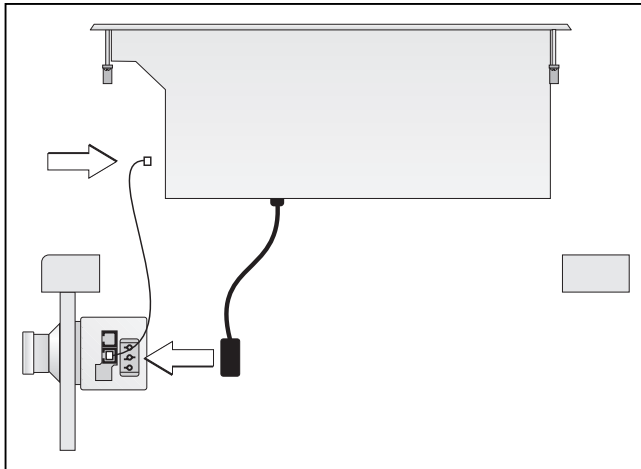

- Firmly plug the connecting cable in the cooktop and in the control panel (the plugs must lock into place).
- Turn the clamping screws to the side. Insert the appliance with the control panel on the front into the cut-out and align it.
Note: do not stick the appliance onto the worktop with silicone.
- Turn the clamping screws under the countertop and tighten them evenly. Do not tighten the clamping screws too tightly, as a uniform sealing gap should be left all round.
- Connect the appliance to the electricity. Test that it functions correctly. If the luminous discs behind both control knobs blink alternately, check the connecting cable between the appliance and the control panel is firmly plugged in.

Drain installation

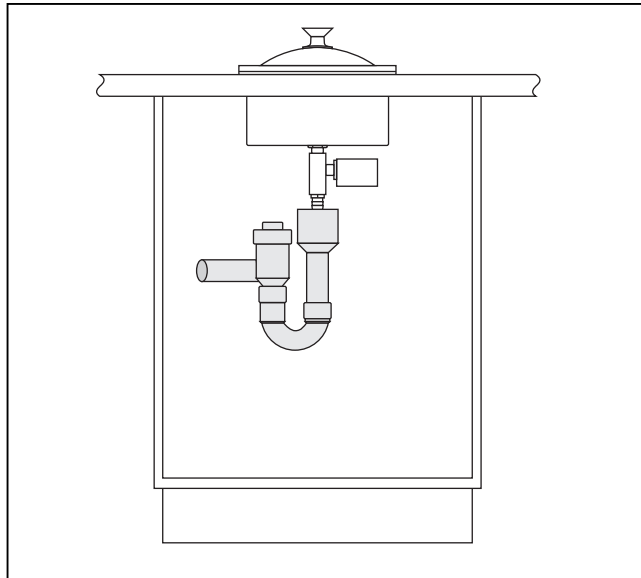
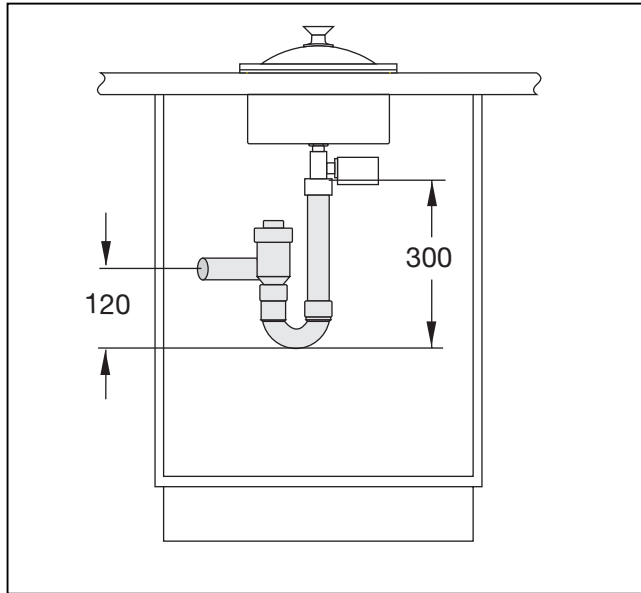

A permanent drain connection using our **drain installation set (AG 050-000)** is recommended. This requires a drain connection in the base cabinet. A non-return valve must be installed. It can be connected permanently or with a free fall.

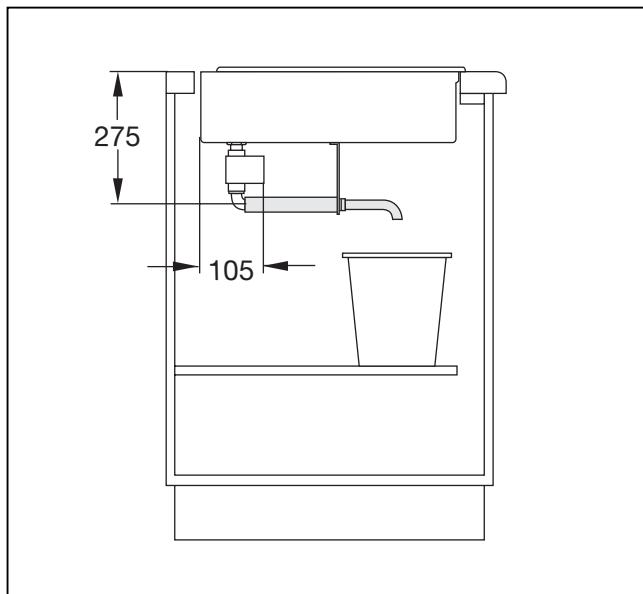

If no drain connection is available, the **drain installation set (AG 060-000)** allows you to drain the cooking liquid into a suitable receptacle (e.g. a 10 l bucket).

GAGGENAU

GAGGENAU HAUSGERÄTE GMBH
CARL-WERY-STR. 34 · D-81739 MÜNCHEN

☎ (089) 45 90-03
FAX (089) 45 90-23 47

www.gaggenau.com