

EcoFlush™
Single Function FlushOmeter
Tank System

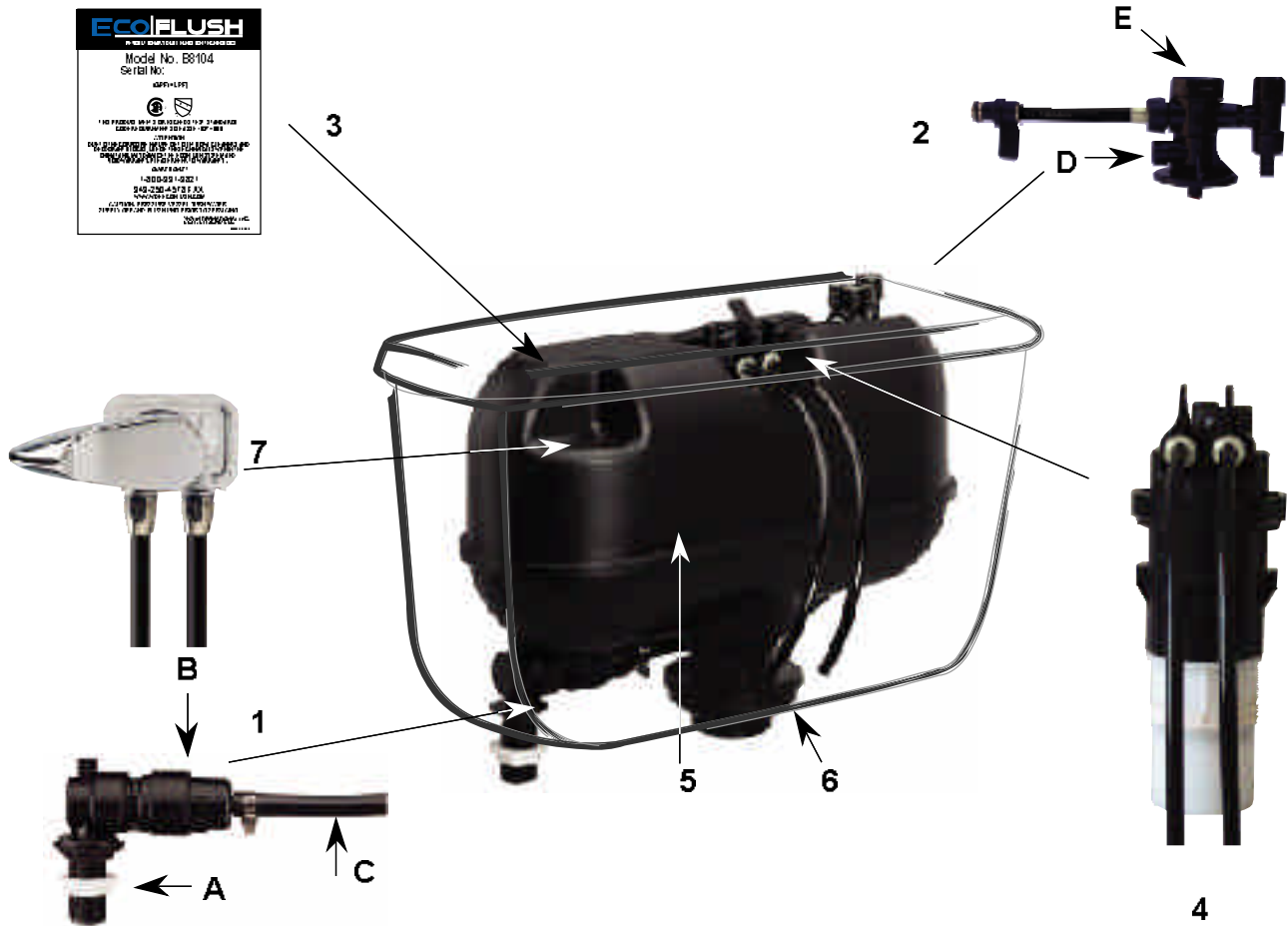

Model B8104
1.1 Gallon/4 Liter/ Flush
System

EcoFlush™ Model B8104 Series-Single Flush System



Components Sub Assemblies of the B8104:

1. Lower Inlet Supply w/Hose

- A. Inlet Connector 15/16" w/filter screen
- B. Pressure regulator & relief valve
- C. Supply hose to upper assembly

2. Upper Supply Assembly

- D. Air Inducer
- E. Anti-Siphon w/check ball valve for back-flow prevention

3. Name Plate w/Product Information

4. Flush Valve Cartridge Assembly(FVC)

Flush lines

5. Vessel

6. Discharge Extension w/Drain

7. Flush Control Valve Assembly

EcoFlush B8104 -Tank system provides the means of saving water and money by providing the highest performance capability available today in the High Efficiency Toilet (HET) category. This means that you may use the 1.1 gallon/4 liters of water per flush to discharge both liquid and solid waste. The Patent Pending Design of the EcoFlush B8104 offers superior cleaning and flushing performance. The performance of the EcoFlush System is enhanced by the induction of air during the filling cycle of the system. The incoming water draws additional air into the vessel during the filling cycle. Once fully charged the upper supply valve closes. This contains the compressed air inside the pressure vessel and creates a powerful air driven piston that drives the water into the bowl for a highly efficient bowl cleansing flush. The EcoFlush B8104 System enhances the performance of the jetted toilet bowl that is designed to work with the EcoFlush System. The combination of design and function offer many unique benefits and features not currently found in any other pressure assisted systems in the market.

Outstanding EcoFlush B8104 Features:

- Positive Bowl Extraction (No Double Flushing)
- Stronger Flushing Action Improves Drainline Carry & Leaves Bowl Cleaner
- Large Water Spot for Reduced Housekeeping
- Saves Water & Money Uses 1.1 Gallon Per Flush
- Larger Trapway to Eliminate Stoppages
- No Water Leakage Between Flushes
- Non-Sweating Tank Enclosure

FACTS, FEATURES AND BENEFITS:

1. Rated as one of the quietest pressure assisted flushing systems currently available.
2. EcoFlush achieves siphon action (the principle necessary to extract waste from a toilet) in approximately one second.
3. It will operate on water line pressures as low as 20PSI and as high as 125PSI.
4. Pressurized flushing action improves drain line carry and virtually eliminates stoppages and repeated flushing.
5. Toilet tanks equipped with EcoFlush will not have condensation, therefore eliminating sweating.
6. It harnesses the pressure of the incoming water by containing the air pressure in the vessel. Then when flushed, pressurized water rushes into the bowl for powerful, quiet and quick flush.
7. EcoFlush complies with ASSE (American Society of Sanitation Engineers) standard A1037-90 pressure assisted tank.

INSTALLATION

CAUTION: When servicing or replacing components to the EcoFlush B8104-Tank System, make certain that the water supply is turned OFF and the toilet is then flushed to relieve the internal air and water pressure inside the vessel.

CAUTION: The EcoFlush pressure-assisted flushing system can only be used with bowls that were specifically designed to accept pressure-actuated tanks. These bowls are referred to as jetted pressure-assisted toilet bowls.

NEVER use lubricants on any of the components unless otherwise specified in this manual.

NEVER use corrosive disinfectants, bowl liquid or solid Chlorine based cleaners or deodorants in the toilet tank. It is known that Chlorine based bowl cleaners deteriorate plastic, which will void the manufacturer's warranty.

NEVER install this pressure-assisted vessel in a gravity flushing water closet tank.

Please follow the toilet manufacturer's instructions that were provided with your new toilet and tank. You must use the gaskets, washers and nuts provided with the toilet and install the toilet tank onto the bowl before connecting the water supply line to the water inlet clear the supply line. Do this by running a couple of gallons of water into a bucket to ensure that the supply is clear of debris. After connecting the supply line, check the locking keys on the flush control lines and the upper supply line. You will notice 3 locking tabs. All the tabs should be locked in place with the tabs pointing upward. Now slowly turn on the water checking carefully for leaks.

How The EcoFlush System Works



A. EcoFlush water filling

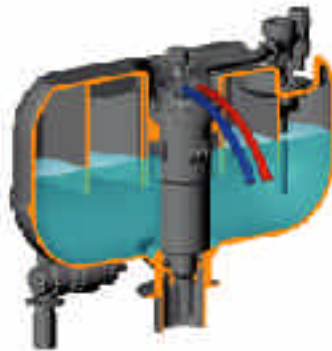

B. As water continues to fill, the air above the water is compressed by rising water in the vessel



C. Air pressure acts as a powerful piston to drive the water from the vessel into the bowl

After installation check the following:

- Verify water pressure: The recommended static pressure range by code is 20 PSI to 125 PSI. If sufficient supply pressure has been verified then:



- Flush the unit several times to clear any excess air trapped in the vessel.
- Note:** If any problem occurs shut off the water supply and flush to relieve any water or air pressure remaining in the vessel.
- If the vessel does not flush, shut off the water supply and remove the connector line nut that connects the upper supply assembly and the flush valve cartridge. Loosening or removal of this line will eliminate the pressure inside the vessel.

TROUBLE SHOOTING

CONDITION 1: No Water Flows Into The Vessel

If the water pressure is below 20 PSI, the unit will not function properly (NOTE: The recommended static pressure range by code is 20 PSI to 125 PSI). If you cannot increase the water pressure to the required level the unit will not function properly.

Check the following to make sure that there is no mechanical reason for the low pressure.



Step 1. Make sure the water supply valve is fully open.

Step 2. Check the Debris Filter Screen for any obstruction that would restrict the water supply pressure. To check the debris screen, shut off the water supply, flush the toilet to discharge any pressure, then disconnect the supply line. Remove the debris screen from the threaded connector shank and flush any debris which might prevent the flow of water through the filter screen. Replace and turn the water supply on checking for leaks.



Step 3. Check to ensure that there are no kinks in the supply lines or connector lines between lower and upper supply assemblies, which would prevent the flow of the water into the system. Also check that there are no leaks at any of the connections.



Step 4. Check the flush control valve for any leaks and make sure the connections are also tight. If water is leaking from the flush control valve then the flush control valve should be replaced (EcoFlush Part Number B8106-06, covered by factory warranty).



Step 5. Check the Flush Valve Cartridge (FVC) for air leaks by pouring a small amount of water onto the area around the top of the flush valve cartridge. If air bubbles are visible then you must remove the FVC and check the flush valve o-ring for damage and to see that it is properly positioned in the vessel.

To remove the Flush Valve Cartridge proceed as follows:

Step a. Shut off the water supply and flush the toilet to remove any remaining water or air pressure before starting the procedure.



Step b. Remove the quick connector line between the Upper Supply Assembly and the Flush Valve Cartridge by rotating the locking tab downward. Remove the supply line and set it aside.



Step c. Disconnect the two black flush control lines from the flush valve cartridge by rotating the locking tabs downward and pull gently outwardly on the lines. These flush control lines are equipped with locking tabs and the lines are connected by left line of the flush control to the left port of the FVC and the right to the right facing port of the FVC.



Step d. Remove the Flush Valve Cartridge (FVC) Assembly using the tool provided. Using the FVC tool, engage the teeth of the tool with the slots on the top of the FVC and with the aid of wrench, rotate the FVC counter clockwise $\frac{1}{4}$ turn, then lift the FVC up removing the FVC and the upper o-ring. Inspect the upper o-ring and the flush valve seat of the Flush Valve Cartridge.



Step e. Reinstall the FVC Assembly. First, position the o-ring in the flush valve seat and then carefully insert the cartridge into the vessel making sure that the o-ring stays in the proper position. Using the tool to align the dual connectors at the 5 o'clock position and while gently pushing down on the cartridge rotate the cartridge clockwise $\frac{1}{4}$ turn to lock the FVC into position with connector ports aligned and facing forward, indicating that the FVC is now locked into the proper position. (DO NOT USE LUBRICANTS ON THE O-RING OR INTERNAL PART OF THE ECOFLUSH AS THIS WILL VOID THE WARRANTY AND CAUSE DAMAGE TO THE SYSTEM.)



Step f. Reconnect the supply lines, (right tab on the right facing port and the left tab on the left facing port) and while pushing the locking keys into place rotate the locking tabs upward to lock the lines into place.



Step g. Reconnect the Upper Supply quick connect line by aligning the locking tab and pushing inward. Rotate the locking tab upward to lock the line into position.



Step h. Turn on the water supply and check all lines carefully for leaks. To ensure that the FVC o-ring is properly seated, pour water onto the top of the FVC and check for air leaks. Test flush the unit several times to clear excess air and continue use.

Step 6. If Step 4 & 5 do not resolve the problem then it will be necessary to replace the flush valve cartridge including the o-ring (EcoFlush part number B8104-03, covered by factory warranty).

CONDITION 2: Water Runs & Will Not Shut Off



(NOTE: The recommended static pressure range by code is 20 PSI to 125 PSI). If sufficient supply pressure has been verified and the toilet continues to run, the following steps may be required:

Step 1. Make sure the water supply valve is fully open.

Step 2. Check the flush control valve for any leaks and make sure the connections are also tight. If water is leaking from the flush control valve then the flush control valve should be replaced (EcoFlush Part Number B8106-06, covered by factory warranty)



Step 3. Check to ensure that there are no leaks in the supply line and connector lines, which would prevent the proper function of the system.

Step 4. Check the Flush Valve Cartridge (FVC) assembly for proper installation and use the water test to check for air leak around the top of the flush valve cartridge. Proceed as follows: If the FVC has an air leak you need to check the flush valve and o-ring seal.



Step 5. Turn off the water supply and flush the toilet to relieve any pressure. Remove the Flush Valve Cartridge (FVC) Assembly using the Flush Valve tool. To remove the Flush Valve Cartridge Assembly, disconnect the 3 lines the supply line from the upper supply assembly and the two lines from the Flush Valve Cartridge(FVC). You may disconnect these lines by moving the tabs into the unlocked position and pulling gently on the lines. Disconnect Upper Supply line to the FVC by loosening the nut that connects the top of the FVC to the Upper Supply Assembly.



Step 6. Using the tool provided engage the interlocking teeth and rotate the FVC counter clockwise $\frac{1}{4}$ turn. Then lift the FVC up removing it from the vessel.



Step 7. Inspect the FVC large o-ring at the top of cartridge and also check the lower o-ring for damage or if it is properly seated. NEVER USE ANY LUBRICANTS ON ANY OF THE PARTS OF THE ECOFLUSH AS THIS WILL VOID THE WARRANTY AND CAUSE DAMAGE TO THE PARTS.

Step 8. Reinstall the Flush Valve Cartridge (FVC) Assembly. First, insert the cartridge into vessel, and while gently pushing down on the cartridge, turn the cartridge clockwise $\frac{1}{4}$ turn to lock the FVC into position with connector ports aligned and facing forward, indicating that the locking lugs are now aligned. Reconnect the flush control valve hoses then turn on the water and check carefully for leaks.



Step 9. If the tank continues to run, remove the FVC and check that the lower piston is in the proper position and check the large o-ring to ensure that it is properly seated. When the vessel is filled and the water stops running, it is an indication that the vessel is filled and ready to continue normal use.

Step 10. If the water continues through the vessel into the toilet after completing Step 1 through 9, the Flush Valve Cartridge should be replaced (EcoFlush part number B8104-03, covered by warranty).



Check lower inlet supply assembly to see if the pressure relief valve is leaking or allowing water to flow into the tank. If water is leaking from the pressure regulator and relief valve of the lower inlet supply assembly, the lower inlet supply assembly must be replaced (EcoFlush Part number B8100-01, covered by factory warranty).

CONDITION 3: Weak or Sluggish Flush

Step 1. (NOTE: The recommended static pressure range by code is 20 PSI to 125 PSI). If sufficient supply pressure has been verified and the toilet continues to run, the following steps may be required. If the pressure is within the above defined limits, then you will want to flush the system a couple of times to remove any debris that may be limiting the flow of water to the vessel.



Step 2. Check for debris in the filter screen system at the water inlet for any obstruction that might limit the flow of water into the vessel. To do this shut off the water supply, flush the unit to relieve any pressure and disconnect the water supply line from the threaded connector. You can remove the filter screen easily using a set of long nose pliers. Clean and replace the filter screen, then reconnect the water supply and check the water flow.



Step 3. Make sure that the vessel has sufficient time to fully recharge (the lower the pressure the longer the time to recharge the vessel). We suggest that you allow at least 2 minutes between flush cycles.

WINTERIZING

The EcoFlush, when installed in a summer home, cottage or cabin, can be winterized to allow for periods for non-use especially when the dwelling is subject to frigid conditions. Follow the procedures outlined below.

Tools: (1) Sponge, (2) Bucket, (3) Adjustable Channel Locks

Tank Procedure:

Step 1. Turn off the water supply line valve and remove the toilet tank lid/cover.

Step 2. Flush the system to discharge all of the water from the vessel.

Step 3. Disconnect the supply line-coupling nut from the connector shank. NOTE: A small amount of water will drip out of the shank. Be prepared to collect it in a bucket or sponge it up. Loosen the hex nut on the connector shank to allow water to drain from the bottom of the toilet tank into a bucket. You may also remove the toilet tank lid and use an old towel to soak up any water that may accumulate in the bottom of the tank.

Step 4. Flush the vessel to ensure that all air and water has been discharged.

Bowl Procedure:

After flushing out the vessel, remove any remaining water from the bowl or add from 1 pint to 1 quart of antifreeze or RV antifreeze to the water remaining in the bowl.

POINTS TO REMEMBER

SAFETY NOTICE

- When servicing any component, the water supply should be turned OFF and the vessel should be flushed normally in order to relieve the air and water pressure.
- The Flush Valve Cartridge Assembly can be removed by using the tool provided, insert the teeth into the slots on circumference of the top of the flush valve into the top of the cartridge and rotate $\frac{1}{4}$ turn in a counter clockwise direction.
- **NEVER** use any corrosive disinfectants, bowl cleaners or deodorant blocks with an EcoFlush B8104 system or in the toilet tank. USE OF ANY CORROSIVE OR CHLORINE BASED CLEANERS IN THE TOILET TANK SHALL BE JUST CAUSE TO VOID THE WARRANTY OF THIS PRODUCT. THESE CHEMICALS ARE KNOWN TO CAUSE DAMAGE TO PLASTIC PARTS.

The EcoFlush 8104 has been engineered to provide reliable performance year after year. However, if servicing is ever required, it is recommended that you follow the instructions included in this brochure. If you would like additional information or require technical assistance, write to us at WDI International 3 Musick Irvine, CA 92618 or call 1-800-391-9821

Instructions for Tamper Resistant Locking

All EcoFlush pressure flushing systems provide the user with the means to deter tampering with the connector lines of the Flush Control Valve B8106-06A Lines. While this feature may be unnecessary for residential use, commercial users and those systems that are used in public restroom facilities will find that this feature will greatly reduce the risk of someone tampering with the connector lines. Remember, when in use, the EcoFlush Vessel contains compressed air and water. And if someone were to remove one of the lines, a protection feature is that the toilet would flush, and at the end of the flush cycle the water flow would continue to flow water into the vessel. If either connector line is left in the unlocked position (point outward left and right), then there is a risk that water could damage the surrounding environment.

The method employed by EcoFlush is simple. Note that each of the connector lines are locked securely into position when the tabs are pointing to the up position with the brass insert plugged into the two control ports of the Flush Valve Cartridge. You will note that each tab has a hole in the center. To utilize the simple tamper proof locking system follow these steps:



A



B



C



D



E



F

Installation Steps:

- A. Locate the wire tie that was sent with the unit.
- B. Thread the end through the three holes of the locking tabs.
- C. Insert the flat wire tie into and through the locking lug.
- D. Pull the flat wire tie and tighten snugly.
- E. Trim the excess away above the wire tie lug.
- F. Locking tabs in the tamper resistant position.

This will provide a reasonable level of security and deter individuals from tampering with the connector lines.

EcoFlush B8104 SYSTEM WARRANTY REGISTRATION

WDI International, Inc. (the company), warrants the EcoFlush B8104 system to be free of defects in material and workmanship for a period of ten (10) years from the date of installation and the Company hereby agrees to replace any part of this product that proves, upon our inspection and within ten years from date of installation, to be defective in material or workmanship. All labor and transportation costs or charges incidental to warranty service are to be borne by the purchaser-user.

This warranty is subject to the following:

Specific Conditions to Warranty

A Warranty Registration card must be fully completed and mailed by the purchaser (the user) to the Company within thirty (30) days of the date of installation. The unit has been subject to proper installation, operation and maintenance as outlined in the installation instructions that were supplied with the unit. Note this warranty is void if the unit is installed and operated subject to water supply line pressure greater than 125PSI (static) or less than 20PSI (static).

Service and repairs may only be performed by authorized representatives of the Company or by others upon specific approval by the Company. Unauthorized repairs or alterations shall specifically void the warranty. Use of Chlorine based liquid or solid bowl cleaners, which have been shown to cause damage to plastic parts, chemical disinfectant or corrosive household cleaners on EcoFlush products or in the toilet tank will void this warranty. Proof of purchase is required.

Exclusions

IN NO EVENT SHALL THE COMPANY BE LIABLE FOR INCIDENTAL OR CONSEQUENTIAL DAMAGES, FOR DAMAGES RESULTING FROM IMPROPER INSTALLATION, OR FOR DAMAGES CAUSED BY NEGLIGENCE, ABUSE OR ALTERATION. ALL IMPLIED WARRANTIES, INCLUDING ANY IMPLIED WARRANTY OF MERCHANTABILITY OR FITNESS FOR ANY PARTICULAR PURPOSE ARE LIMITED TO A PERIOD OF TEN (10) YEARS FROM DATE OF INSTALLATION.

Some states do not allow limitation on the duration of an implied warranty and some states do not allow exclusions or limitations regarding incidental or consequential damages, so the above limitations may not apply to you. This warranty gives you specific legal rights and you may have other rights, which vary from state to state. No person is authorized to change, add to, or create any warranty or obligation other than that set forth herein. To obtain warranty service contact Consumer Services at the following:

WDI International, Inc.
3 Musick
Irvine, CA 92618
EcoFlush Technical Support
Toll Free Number
1 800 391 9821
949 250 4576 Office
<http://www.WDI-EcoFlush.com>

WARRANTY INFORMATION
Model EcoFlush B8104

Installation Date _____

Serial Number _____

EcoFlush B8104 Lower Inlet Supply Assembly

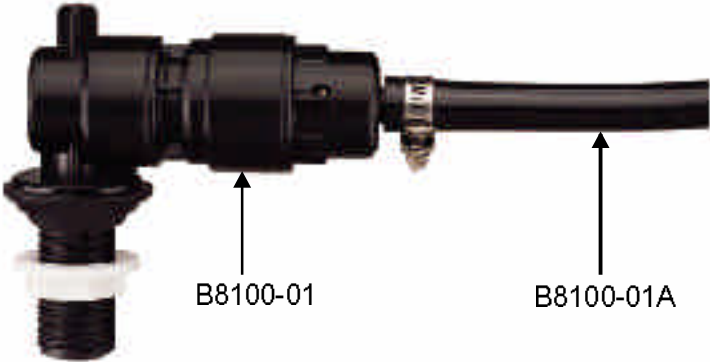

Parts View of Lower Inlet Supply Assembly

Part Description
 Lower Supply w/Pressure Relief Valve
 Upper Supply Tube (Black)

Part Number
 B8100-01
 B8100-01A

EcoFlush Upper Supply Assembly

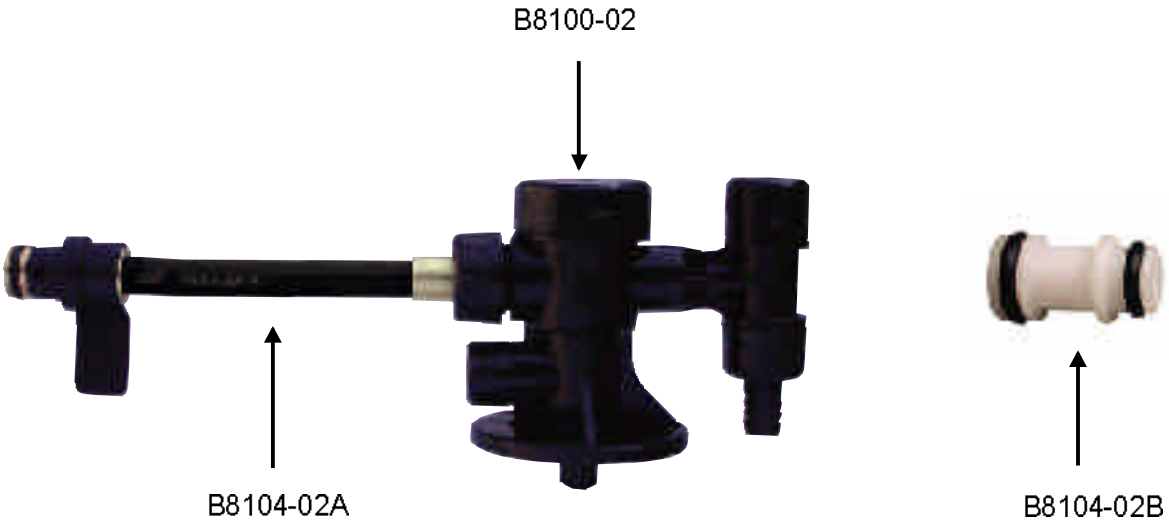

Parts View of Upper Supply Assembly

Part Description
 Upper Supply Assembly (tube not included)
 Quick Couple Supply Tube
 Flow Reducer

Part Number
 B8100-02
 B8104-02A
 B8104-02B

EcoFlush B8104 Flush Valve Cartridge



Flush Valve Cartridge (FVC) Assembly

Part Description

Complete Flush Valve Cartridge Assembly
(Connector lines not included)

Part Number

B8104-03

In any case where the actual part does not match the color of the parts photograph, please accept the actual part as it is sent to you as color does not impact the function or form of the part.

B8104 Flush Control Valve Assembly



Front View



Back View

Part Description

Complete FCV
Includes the FCV control lines (14") with quick connector locking tabs.

Part Number

B8106-06

Part Description

Flush valve control lines and connectors only

Part Number

B8106-06A



B8106-06A Includes:
2 each 14inch FCV connector tubes with stainless steel female nuts and quick couple connectors.

EcoFlush Flush Levers



Chrome



Chrome

EcoFlush Handle

Part Description	Part Number for Left Handed Lever	Part Number for Right Handed Lever	Part Number for Push Button
Polished Chrome	BS004CLV	BS004CRV	BS004C-PB
Polished Brass	BS004PBLV	BS004PBRV	BS004PB-PB
White	BS004WLV	BS004WRV	BS004W-PB
Bone	BS004BNLV	BS004BNRV	BS004BN-PB
Biscuit	BS004BSLV	BS004BSRV	BS004BS-PB
Satin Nickel	BS004SNLV	BS004SNRV	BS004SN-PB
Rubbed Bronze	BS004RBLV	BS004RBRV	BS004RB-PB