

ITHACA

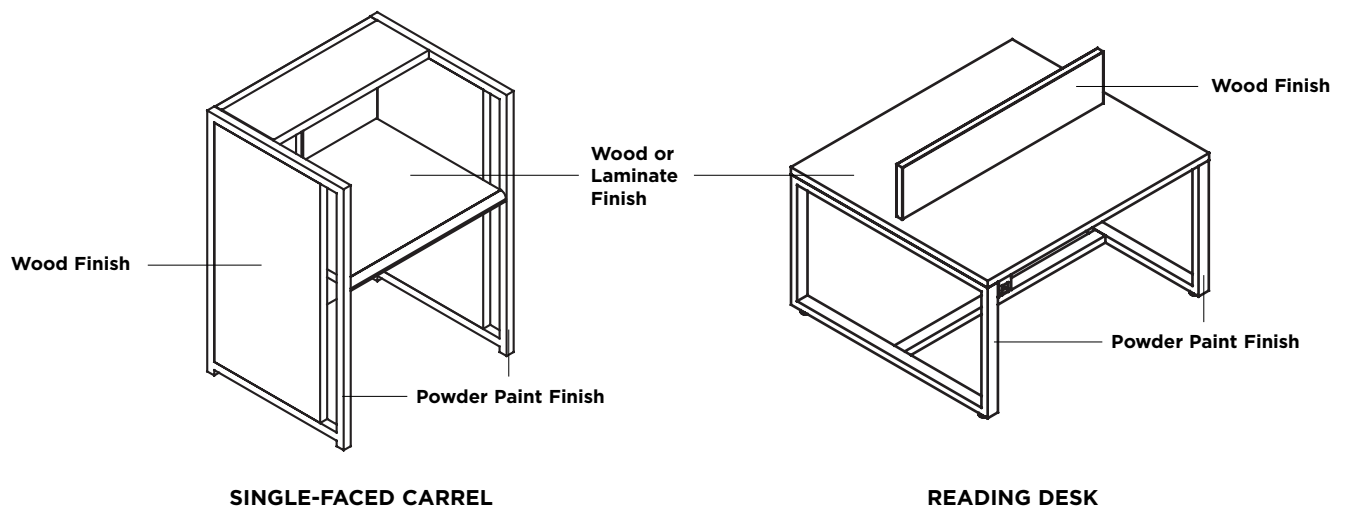

The Ithaca collections can be defined as quiet, composed and orderly. This clean-lined design is sophisticated yet unadorned with a simple elegance and a sense of purpose. Ithaca's design allows for the opportunity to place this furniture almost in any setting.

- All components, from tables to seating, incorporate the use of wood and metal creating a look that compliments a variety of architectural styles.
- A variety of study options are available including carrels, workstations, study desks and computer desks.
- Kiosks create perfect walk-up patron access stations.
- Carrels and kiosks as well as all work surfaces are available in a variety of beautiful veneers.
- Complimentary lounge furniture completes the line, once again incorporating wood and metal along with upholstery.
- Occasional tables match Ithaca's other tables and include side and coffee tables in a variety of shapes and sizes.



KIOSKS AND CARRELS

Upright Panels:

Upright panels on kiosks and carrels are constructed of 17/16" thick 45-lb. density industrial grade particle board covered on both sides with .031" thick wood veneer. A metal frame surrounds the wood panel. This steel, tube frame is finished in environmentally friendly powder paint.

On add-on units, four-pack and six-pack units, holes are cut on the middle panels to allow for cord management.

Back panels on Carrels only (not on Kiosks) feature a reveal that runs down the length of the panel until just under the work surface. This reveal measures 1" x 3/8" and is concealed by a metal cover. This reveal, while creating a design element, also provides cord management when a light is used on the carrel.

Work surfaces:

work surfaces are constructed of 17/16" thick 45-lb. density industrial grade particle board covered on one side with .031" thick wood veneer or high-pressure laminate and the other side a backer. Two edge details are available on the work surfaces (except on the 60 Degree Radius Carrel which is only available with a 3mm hardwood edge). The first edge detail is a hardwood waterfall edge which provides added comfort. The second edge detail is a 3mm square hardwood edge.

PLEASE NOTE:

Due to the differing heights of the 36"W and 48"W carrels, you CAN NOT use them in combination. For example, you can not order a 36"W starter unit and a 48"W add-on unit because the height of the 36"W unit is 48"H while the 48"W unit is 60"H.

Top Shelf:

All Carrels (not Kiosks) feature a top shelf. This shelf is constructed of 17/16" thick 45-lb. density industrial grade particle board covered on both sides with .031" thick wood veneer. Measures 11" deep.

Single-Faced Kiosk:

Overall Dimensions: 36"W (starter) or 35"W (add-on) x 24"D x 56"H
Work surface Height: 40"

Double-Faced Kiosk:

Overall Dimensions: 36"W (starter) or 35"W (add-on) x 46 1/2"D x 56"H
Work surface Height: 40"

Four-Pack Kiosk:

Overall Dimensions: 70 1/2"W x 46 1/2"D x 56"H
Work surface Height: 40"

Six-Pack Kiosk:

Overall Dimensions: 104 1/2"W x 46 1/2"D x 56"H
Work surface Height: 40"

36"W Single-Faced Carrel:

Overall Dimensions: 36"W (starter) or 35"W (add-on) x 29"D x 48"H
Work surface Height: 30"

36"W Double-Faced Carrel:

Overall Dimensions: 36"W (starter) or 35"W (add-on) x 56 1/2"D x 48"H
Work surface Height: 30"

36"W Four-Pack Carrel:

Overall Dimensions: 70 1/2"W x 56 1/2"D x 48"H
Work surface Height: 30"

36"W Six-Pack Carrel:

Overall Dimensions: 105"W x 56 1/2"D x 48"H
Work surface Height: 30"

48"W Single-Faced Carrel:

Overall Dimensions: 48"W (starter) or 47"W (add-on) x 29"D x 60"H
Work surface Height: 30"

48"W Double-Faced Carrel:

Overall Dimensions: 48"W (starter) or 47"W (add-on) x 56 1/2"D x 60"H
Work surface Height: 30"

48"W Four-Pack Carrel:

Overall Dimensions: 94 1/2"W x 56 1/2"D x 60"H
Work surface Height: 30"

48"W Six-Pack Carrel:

Overall Dimensions: 141"W x 56 1/2"D x 60"H
Work surface Height: 30"

Task Light:

The task light (sold separately) can attach to the underside of the top shelf on carrels. A reveal found in the back panel of the carrel provides cord management for the light. The task light features an on/off switch and 9' cord. UL and C-UL listed.

Overall Dimensions: 22 1/4"W x 5"D x 1 1/8"H

Flip-Up Power Grommet:

The Flip-Up Power Grommet consists of two outlets and two data ports (data jacks must be purchased elsewhere). Power Grommets are available in Black or Silver. Power Grommets must be ordered at the same time as the Kiosk or Carrel so a hole may be cut in the work surface to accept it.

60 Degree Radius Carrel:

The 60 Degree Radius Carrel's upright panels feature the same construction as all other carrels. The back panels, however, are radiused 60 degrees. No task lighting can be used on the top shelf of this carrel. The work surface is only available with a 3mm edge (waterfall edge not available).

60 Degree Radius Carrel:

Overall Dimensions: 49 1/4"W (starter) or 48"W (add-on) x 31 3/4"D x 60"H
work surface Height: 30"

WORKSTATIONS AND TABLES

Work surfaces:

Worksurfaces are constructed of 17/16" thick 45-lb. density industrial grade particle board covered on one side with .031" thick wood veneer or high-pressure laminate and the other side a backer. All edges are a 3mm hardwood edge.

Bases:

Bases are constructed of metal tubing and finished using an environmentally friendly powder paint process. A steel stretcher, integrated into the base, attaches to the underside of the table work surface to provide added durability to the top. The underside of the base features leveling inserts that accept threaded nylon levelers to allow for easy leveling. On tables, a hollow stretcher for cord management runs from the underside of the table to the floor,

Workstations are designed to be sat at on one side of the table while tables are designed to be sat at from both sides.

Workstations:

Overall Dimensions: 54"W or 78"W x 30"D x 30"H

Tables:

Overall Dimensions: 54"W, 72"W or 96"W x 48"D x 30"H

Flip-Up Power Grommet:

The Flip-Up Power Grommet consists of two outlets and two data ports (data jacks must be purchased elsewhere). Power Grommets, by Byrne, Electrical Specialists, are available in Black or Silver.

Workstations can be ordered with Power Grommets as an option. Power Grommets must be ordered at the same time as the workstation so a hole may be cut in the work surface to accept them. 54"W work surfaces come with one grommet placed in the center of the back side of the work surface while 78"W workstations include two power grommets also placed at the rear of the work surface. Cut out size 6¹/₃₂"W x 2¹⁵/₃₂"D. Cord measures 6' long.

Overall Dimensions: 7"W x 3"D x 17⁷/₈"H (when open)

READING DESKS

Reading Desks are constructed the same way a Table is constructed. It is intended that a reading desk be sat at on both sides of the work surface.

Privacy Partition:

The only difference between a Table and Reading Desk is the addition of a partition that provides privacy from one side of the table to the other. The Privacy Partition runs down the center of the table, lengthwise, creating two sides of the table.

The Privacy Partition is constructed of 17⁷/₁₆" thick 45-lb. density industrial grade particle board and covered on both sides with .031" thick wood veneer. The partition measures 11" high.

Overall Dimensions: 54"W, 72"W or 96"W x 48"D x 41"H
work surface Height: 30"

Flip-Up Power Grommet:

The Flip-Up Power Grommet can be ordered for the Reading Desks as an option. 54"W Reading Desks include two power grommets, one on either side of the partition. 72" and 96"W reading desks include four power grommets, two on either side of the partition. Power Grommets must be ordered at time of the desk so a hole may be cut in the work surface to accept them. Cut out size 6¹/₃₂"W x 2¹⁵/₃₂"D. Cord measures 6' long.

COMPUTER DESKS

Computer Desks are constructed the same way a Workstation is constructed. It is intended that a computer desk be sat at on one side of the work surface.

Computer Shelf:

The only difference between a Workstation and Computer Desk is the addition of a computer shelf that provides an added elevation for the placement of a computer monitor. The computer shelf runs along the back side of the work surface. Underneath the computer shelf is a partition that separates the space.

The Computer Shelf is constructed of 45-lb. density industrial grade particle board and covered on all sides with .031" thick wood veneer. The end caps of the computer shelf have holes cut in them for easy cord management. The shelf measures 7" high.

Overall Dimensions: 54"W or 78"W x 30"D x 37"H
work surface Height: 30"

Flip-Up Power Grommet:

The Flip-Up Power Grommet can be ordered for the Computer Desks as an option. When ordered, all Computer Desks, regardless of size, include two power grommets. Power Grommets must be ordered at time of the desk so a hole may be cut in the work surface to accept them. Cut out size 6¹/₃₂"W x 2¹⁵/₃₂"D. Cord measures 6' long.

STUDY DESKS

Study Desks are constructed the same way a Table is constructed. It is intended that a Study Desk be sat at on both sides of the work surface.

Study Divider:

The only difference between a Table and Study Desk is the addition of a divider that divides the table work surface into four quadrants.

The Study Divider is constructed of 17⁷/₁₆" thick 45-lb. density industrial grade particle board and covered on both sides with .031" thick wood veneer. The divider measures 16" high. Divider divides the work surface into four sections, and also includes side panels creating a "carrel" desk.

Overall Dimensions: 72"W x 48"D x 46"H
work surface Height: 30"

Flip-Up Power Grommet:

The Flip-Up Power Grommet can be ordered for the Study Desks as an option. The Study Desk includes four power grommets, one in each quadrant of the desk. Power Grommets must be ordered at time of the desk so holes may be cut in the work surface to accept them. Cut out size 6¹/₃₂"W x 2¹⁵/₃₂"D. Cord measures 6' long.

LOUNGE SEATING

All lounge seating has a similar construction with metal legs, a wood shell, and fabric seats and arms.

Wood Shell:

The wood shell is constructed of a MDF core covered with veneer. A 3mm hardwood edge is on the top and front planes for edge protection. The back corner joints are splined miters that have a poplar cleat to increase the glue surface area and to allow for mechanical fasteners (brads and or screws) to be applied from the inside of the joint.

Upholstered frame components consist of both 1¹/₈" and 3³/₄" engineered plywood incorporating double dowel construction and glue blocks to reinforce critical joints.

Metal Base:

A tubular steel base is fabricated from 16-gauge x 1¹/₂" square tubing. It is covered in environmentally safe powder paint. The tubing ends receive leveling inserts that accompany threaded nylon levelers to allow for easy leveling.

Upholstery:

The tailored cushion on all lounge seating consists of a 4" seat. The lounge chair, settee and sofa also consist of a 2" foam back. These pieces are made from combustion modified (Cal. 117) FPF (flexible polyurethane foam) with a density of 1.45 and IFD (indentation force deflection ratio) of 33-39 with a .75 oz bonded polyester fiber wrap to ensure durability while adding crown. In both the seat and the back, 2" elastic webbing is cross woven in a 5 x 5 pattern that is stretched and attached to the frame with steel staples. FLW (flock loose webbing) sheeting is placed on the webbing to insulate the foam from the webbing. Arm tops consist of one layer 1¹/₄" 65 IFD and a second layer of 1¹/₂" FPF with a 36 IFD followed by a .6 oz layer of bonded polyester fiber wrap. The inside arm has Propex sheeting that is stretched and stapled over the frame member followed by 1¹/₄" 65 ILD foam with a .75 oz bonded polyester fiber wrap.

For COM and COL yardage requirements see page 12.

Lounge Chair:

Overall Dimensions: 34"W x 29¹/₂"D x 33"H
Seat Height: 16"
Arm Height: 24"
Arm Width: 5¹/₄"

Settee:

Overall Dimensions: 57¹/₂"W x 29¹/₂"D x 33"H
Seat Height: 16"
Arm Height: 24"
Arm Width: 5¹/₄"

Sofa:

Overall Dimensions: 86¹/₄"W x 29¹/₂"D x 33"H
Seat Height: 16"
Arm Height: 24"
Arm Width: 5¹/₄"

Single Bench:

Overall Dimensions: 36"W x 24"D x 25"H
Seat Height: 19"
Arm Height: 24"
Arm Width: 4¹/₄"

Double Bench:

Overall Dimensions: 60"W x 24"D x 25"H
Seat Height: 19"
Arm Height: 24"
Arm Width: 4¹/₄"

Triple Bench:

Overall Dimensions: 84"W x 24"D x 25"H
Seat Height: 19"
Arm Height: 24"
Arm Width: 4¹/₄"

OCCASIONAL TABLES

Table Top and Sides:

The occasional table tops and sides are constructed of MDF finished on both sides with veneer. All joints of the shell (consisting of the top and sides) are a splined miter construction. The front and back faces are edge banded with plain sliced 10-mil resin impregnated paper-backed veneer that is applied with the grain running vertically.

Metal Base:

All occasional tables are constructed using a metal base on which the table top and sides are attached. The metal base is constructed of a 16-gauge x 1" square tube. It is finished in environmentally safe powder paint. The tubing ends receive leveling inserts that accompany threaded nylon levelers to allow for on site leveling.

Small Side Table Open:

Overall Dimensions: 18"W x 18"D x 22"H

Medium Side Table Open:

Overall Dimensions: 18"W x 26"D x 22"H

Large Side Table Open:

Overall Dimensions: 22"W x 22"D x 22"H

Small Coffee Table Open:

Overall Dimensions: 24"W x 42"D x 17"H

Large Coffee Table Open:

Overall Dimensions: 36"W x 36"D x 17"H

ITHACA KIOSKS

PRODUCT	MODEL #	DESCRIPTION	WORK SURFACE HEIGHT
---------	---------	-------------	---------------------

SINGLE-FACED KIOSK

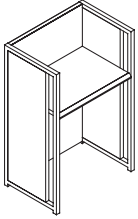

STARTER UNIT SHOWN

IHK3624KS-__	36"W x 24"D x 56"H, Starter	40"
IHK3624KA-__	35"W x 24"D x 56"H, Add-on	40"

DOUBLE-FACED KIOSK

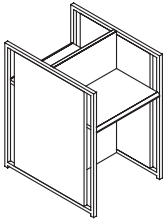

STARTER UNIT SHOWN

IHK3646KS-__	36"W x 46 1/2"D x 56"H, Starter	40"
IHK3646KA-__	35"W x 46 1/2"D x 56"H, Add-on	40"

KIOSK FOUR-PACK

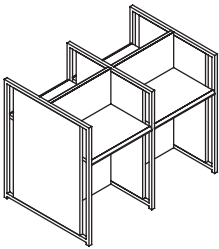

IHK7046K4-__	70 1/2"W x 46 1/2"D x 56"H, 4-Pack	40"
--------------	------------------------------------	-----

KIOSK SIX-PACK

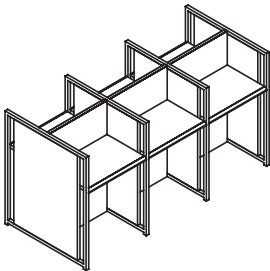

IHK10546K6-__	104 1/2"W x 46 1/2"D x 56"H, 6-Pack	40"
---------------	-------------------------------------	-----

When ordering Kiosks, you may decide if you would like a flip-up power grommet as an option to provide power to the work surface (additional charge). If you choose to order a power unit, you must decide if you would like it to be black or silver.

While the flip-up power unit can be ordered separately, it is recommended you order it at the time you order your kiosk so that Bretford can cut a hole in the work surface to accept it.

In addition, you may choose a laminate or veneer worksurface. When ordering a laminate worksurface, include the code for your laminate choice. When ordering a veneer worksurface, use the code "VEN" and the veneer finish code.

With both a laminate and veneer worksurface, you may choose a 3mm hardwood edge or a hardwood waterfall edge for your worksurface. Choose the appropriate edge detail code when ordering.

HOW TO ORDER KIOSKS:

Example: Kiosk Six-Pack; Aluminum Paint; Veneer work surface; Natural Maple Veneer; Waterfall Edge; No Power

IHK10546K6	AL	VEN	M2	W	N
Model Number	Paint Color	Laminate or Veneer (VEN) work surface	Veneer	3mm Edge (S) or Waterfall Edge (W)	Power Black (B), Power Silver (S) or No Power (N)

ITHACA COMPUTER CARRELS

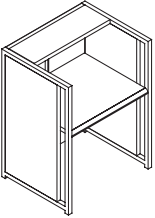
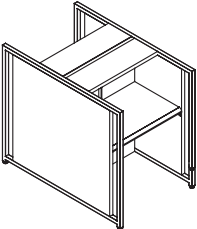
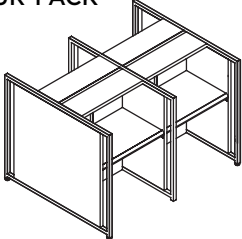
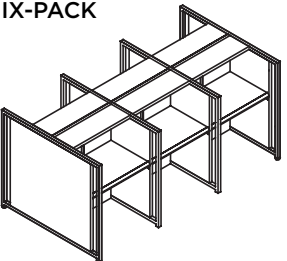
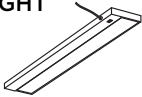
PRODUCT	MODEL #	DESCRIPTION	WORKSURFACE HEIGHT
SINGLE-FACED 36"W COMPUTER CARREL			
 <p>STARTER UNIT SHOWN</p>	IHC3629CS-__	36"W x 29"D x 48"H, Starter	30"
	IHC3629CA-__	35"W x 29"D x 48"H, Add-on	30"
DOUBLE-FACED 36"W COMPUTER CARREL			
 <p>STARTER UNIT SHOWN</p>	IHC3656CS-__	36"W x 56 1/2"D x 48"H, Starter	30"
	IHC3656CA-__	35"W x 56 1/2"D x 48"H, Add-on	30"
36"W COMPUTER CARREL FOUR-PACK			
	IHC7056C4-__	70 1/2"W x 56 1/2"D x 48"H, 4-Pack	30"
36"W COMPUTER CARREL SIX-PACK			
	IHC10556C6-__	105"W x 56 1/2"D x 48"H, 6-Pack	30"
TASK LIGHT			
	IETTASLKT	Task Light	

PLEASE NOTE:
 Due to the differing heights of the 36"W and 48"W carrels, you CAN NOT use them in combination.

When ordering Carrels, you may decide if you would like a flip-up power grommet as an option to provide power to the worksurface. If you choose to order a power unit, you must decide if you would like it to be black or silver.

While the flip-up power unit can be ordered separately, it is recommended you order it at the time you order your carrel so that Bretford can cut a hole in the worksurface to accept it.

Task lighting is sold separately. The top shelf of the carrel, however, is manufactured to accept the light. The reveal cut in the back panel of the carrel is a design feature as well as provides cord management for the light.

In addition, you may choose a laminate or veneer worksurface. When ordering a laminate worksurface, include the ordering code for your laminate choice. When ordering a veneer worksurface, use the code "VEN" and the veneer finish code.

With both a laminate and veneer worksurface, you may choose a 3mm hardwood edge or a hardwood waterfall edge for your worksurface. Choose the appropriate edge detail code when ordering.

HOW TO ORDER 36"W COMPUTER CARRELS:

Example: 36"W Double-Faced Computer Carrel Starter; Raven Paint; Bronze Legacy Laminate Worksurface; Medium Cherry Veneer; 3mm Edge; With Black Power Grommet

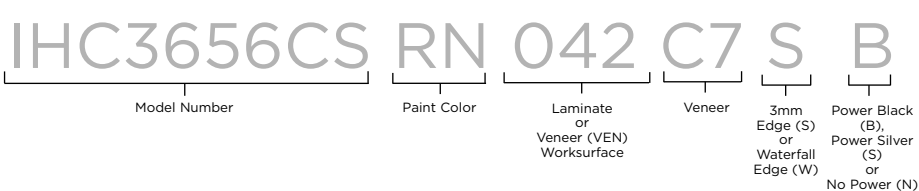

ITHACA COMPUTER CARRELS

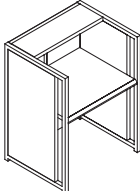
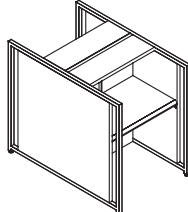
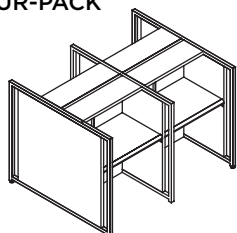
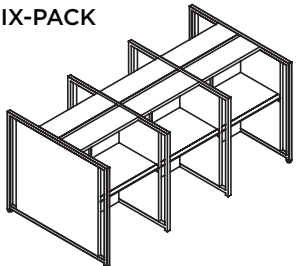
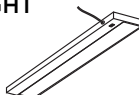
PRODUCT	MODEL #	DESCRIPTION	WORKSURFACE HEIGHT
SINGLE-FACED 48"W COMPUTER CARREL			
 <p>STARTER UNIT SHOWN</p>	IHC4829CS-__	48"W x 29"D x 60"H, Starter	30"
	IHC4829CA-__	47"W x 29"D x 60"H, Add-on	30"
DOUBLE-FACED 48"W COMPUTER CARREL			
 <p>STARTER UNIT SHOWN</p>	IHC4856CS-__	48"W x 56 1/2"D x 60"H, Starter	30"
	IHC4856CA-__	47"W x 56 1/2"D x 60"H, Add-on	30"
48"W COMPUTER CARREL FOUR-PACK			
	IHC9456C4-__	94 1/2"W x 56 1/2"D x 60"H, 4-Pack	30"
48"W COMPUTER CARREL SIX-PACK			
	IHC14156C6-__	141"W x 56 1/2"D x 60"H, 6-Pack	30"
TASK LIGHT			
	IETTASKLT	Task Light	

PLEASE NOTE:
 Due to the differing heights of the 36"W and 48"W carrels, you **CAN NOT** use them in combination.

When ordering Carrels, you may decide if you would like a flip-up power grommet as an option to provide power to the worksurface. If you choose to order a power unit, you must decide if you would like it to be black or silver.

While the flip-up power unit can be ordered separately, it is recommended you order it at the time you order your carrel so that Bretford can cut a hole in the worksurface to accept it.

Task lighting is sold separately. The top shelf of the carrel, however, is manufactured to accept the light. The reveal cut in the back panel of the carrel is a design feature as well as provides cord management for the light.

In addition, you may choose a laminate or veneer worksurface. When ordering a laminate worksurface, include the ordering code for your laminate choice. When ordering a veneer worksurface, use the code "VEN" and the veneer finish code.

With both a laminate and veneer worksurface, you may choose a 3mm hardwood edge or a hardwood waterfall edge for your worksurface. Choose the appropriate edge detail code when ordering.

HOW TO ORDER 48"W COMPUTER CARRELS:

Example: 48"W Single-Faced Computer Carrel Add-on; Aluminum Paint; Veneer Worksurface; Natural Oak Veneer; 3mm Edge; No Power

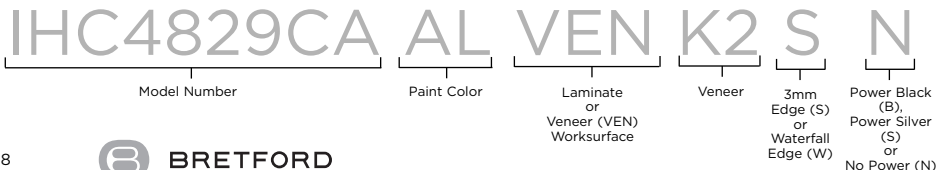

ITHACA 60 DEGREE RADIUS CARRELS

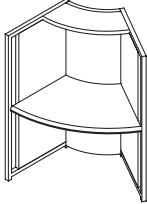
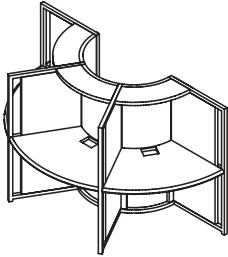
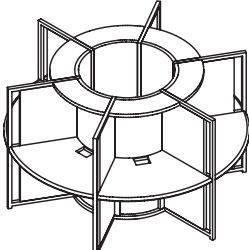
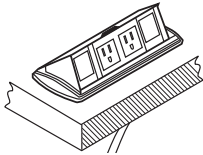
PRODUCT	MODEL #	DESCRIPTION	WORKSURFACE HEIGHT
SINGLE CARREL			
 <p>STARTER UNIT SHOWN</p>	IHC5060CS-__	49 1/4"W x 31 1/4"D x 60"H, Starter	30"
	IHC5060CA-__	48 1/4"W x 31 1/4"D x 60"H, Add-on	30"
CARREL THREE-PACK			
 <p>SHOWN W/OPTIONAL POWER CUTOUT</p>	IHC50180C3-__	8' 2 1/4"W x 4' 8 7/8"D x 60"H, 3-Pack	30"
CARREL SIX-PACK			
 <p>SHOWN W/OPTIONAL POWER CUTOUT</p>	IHC50360C6-__	8' 2 1/4"W x 8' 2 1/4"D x 60"H, 6-Pack	30"
POWER GROMMET			
	IET4000WPB	Flip-Up Power Grommet - Black	
	IET4000WPS	Flip-Up Power Grommet - Silver	

When ordering 60 Degree Radius Carrels, you may decide if you would like a flip-up power grommet as an option to provide power to the worksurface. If you choose to order a power unit, you must decide if you would like it to be black or silver.

While the flip-up power unit can be ordered separately, it is recommended you order it at the time you order your carrel so that Bretford can cut a hole in the worksurface to accept it.

In addition, you may choose a laminate or veneer worksurface. When ordering a laminate worksurface, include the ordering code for your laminate choice. When ordering a veneer worksurface, use the code "VEN" and the veneer finish code.

The 60 Degree Radius Carrel only comes with the 3mm hardwood edge.

Task lighting is not available for use on 60 Degree Radius Carrels.

HOW TO ORDER 60 DEGREE RADIUS CARRELS:

Example: 60 Degree Radius Three-Pack; Raven Paint; Metallic Gauze Laminate; Medium Cherry Veneer; With Black Power Grommets



ITHACA WORKSTATIONS AND TABLES

PRODUCT	MODEL #	DESCRIPTION	WORKSURFACE HEIGHT
---------	---------	-------------	--------------------

WORKSTATION

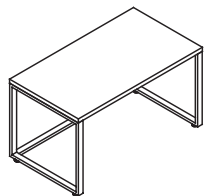

IHT3054WD-__ 54"W x 30"D

30"

IHT3078WD-__ 78"W x 30"D

30"

54"W WORKSTATION SHOWN

TABLE

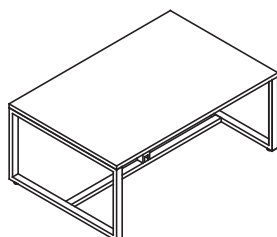

IHT4854TD-__ 54"W x 48"D

30"

IHT4872TD-__ 72"W x 48"D

30"

IHT4896TD-__ 96"W x 48"D

30"

72"W x 48"D TABLE SHOWN

When ordering Workstations, you may decide if you would like a flip-up power grommet as an option to provide power to the work surface. If you choose to order a power unit, specify if you would like it to be black or silver.

While power grommets can be ordered separately, it is recommended you order them at the time you order your table so that Bretford can cut a hole in the worksurface to accept them.

You may choose a laminate or veneer worksurface. When ordering a laminate work surface, include the ordering code for your laminate choice. When ordering a veneer worksurface, use the code "VEN" and the veneer finish code. Both laminate and veneer worksurfaces include a 3mm hardwood edge.

HOW TO ORDER WORKSTATIONS:

Example: 78"W Workstation; Aluminum Paint; Veneer Worksurface; Natural Oak Veneer; No Power

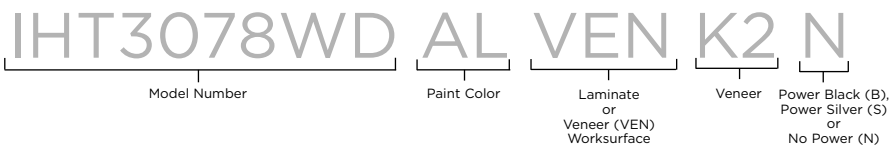

HOW TO ORDER TABLES:

Example: 72"W x 48"D Table; Raven Paint; Grey Nebula Laminate; Sapeli Veneer

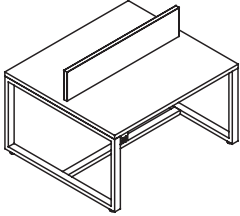
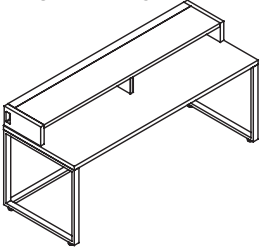
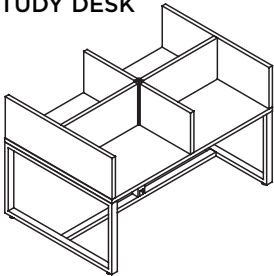
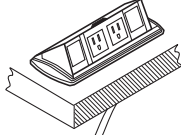

ITHACA DESKS

PRODUCT	MODEL #	DESCRIPTION	WORKSURFACE HEIGHT
READING DESK			
	IHD4854RD-__	54"W x 48"D x 41"H	30"
	IHD4872RD-__	72"W x 48"D x 41"H	30"
	IHD4896RD-__	96"W x 48"D x 41"H	30"
54"W READING DESK SHOWN			
COMPUTER DESK			
	IHD3054CD-__	54"W x 30"D x 37"H	30"
	IHD3078CD-__	78"W x 30"D x 37"H	30"
78"W COMPUTER DESK SHOWN			
STUDY DESK			
	IHD4872SD-__	72"W x 48"D x 46"H	30"
POWER GROMMET			
	IET4000WPB	Flip-Up Power Grommet - Black	
	IET4000WPS	Flip-Up Power Grommet - Silver	

When ordering Reading Desks, Computer Desks or Study Desks, you may decide if you would like a flip-up power grommet as an option to provide power to the worksurface. If you choose to order a power unit, you must decide if you would like it to be black or silver.

While power grommets can be ordered separately, it is recommended you order them at the time you order your table so that Bretford can cut a hole in the worksurface to accept them.

You may choose a laminate or veneer worksurface. When ordering a laminate work surface, include the ordering code for your laminate choice. When ordering a veneer worksurface, use the code "VEN" and the veneer finish code. Both laminate and veneer worksurfaces include a 3mm hardwood edge.

HOW TO ORDER READING AND COMPUTER DESKS:

Example: 54"W Computer Desk; Raven Paint; Veneer Worksurface; Chau Cherry Veneer; With Black Power Grommet

IHD3054CD RN VEN C8 B

Model Number Paint Color Laminate or Veneer (VEN) Worksurface Veneer Power Black (B), Power Silver (S) or No Power (N)

HOW TO ORDER STUDY DESKS:

Example: 72"W x 48"D Study Desk; Raven Paint; Wrought Iron Laminate; Sapeli Veneer; With Silver Power Grommet

IHD4872SD RN 469 S4 S

Model Number Paint Color Laminate or Veneer (VEN) Worksurface Veneer Power Black (B), Power Silver (S) or No Power (N)

ITHACA LOUNGE SEATING

FABRIC GRADE-IN PROGRAM

Bretford's Grade-In program has been designed to offer a host of benefits to customers for all Bretford Ithaca Series soft seating. Bretford has partnered with Momentum* and Herman Miller, Inc. (HMI) fabrics and Wollsdorf leather to offer hundreds of options that are now graded into Bretford's price list. Customers simply pick a graded fabric, vinyl or leather pattern, grade and color, place an order with Bretford and Bretford will take care of everything else. Material testing is no longer required.

Upholstery pricing for the Grade-In program is available at www.Bretford.com. Color options as well as fabric and vinyl samples can be viewed and ordered through the Momentum Group's website at www.themomgroup.com, through Wollsdorf for leather samples at sales@wollsdorfleather.com and through www.Bretford.com for HMI fabric samples.

*Bretford offers all Momentum Textiles as standard. Loomsource nor Textus are offered as a Bretford standard.

CUSTOMER'S OWN MATERIAL TESTING REQUIREMENTS

We reserve the right to reject a fabric or leather which we deem unsuitable for the application intended. WE CAN NOT ASSUME RESPONSIBILITY FOR THE DURABILITY OR TAILORING QUALITY OF COM FABRIC.

COM/COL material should be shipped, prepaid, to the following address:

ITHACA LOUNGE SEATING
 Bretford Manufacturing Inc.
 Attn: COM Material Order # (include your order number)
 11000 Seymour Avenue
 Franklin Park, IL 60131

COM and COL material will be applied at our discretion, unless other specific instructions accompany the order. CUSTOMER MUST SPECIFY ON THE ORDER IF THE FABRIC IS TO BE MATCHED. Normally, without instructions requesting otherwise, fabric will be railroaded as shown below.



Railroaded Fabric

Fire Codes:

California TB117
 All Bretford standard soft seating is produced with materials that meet California TB117.

California TB133
 Contact Customer Service for a quotation. The customer will have to purchase one arm chair to be subjected to the burn-certification test plus a fee for the test.

CUSTOMER'S OWN MATERIAL REPEAT PATTERN REQUIREMENTS

COL requirements are shown in square feet and are based on hides that average a minimum of 50 to 55 square feet each. Increase COL footage requirements 15% when using hides smaller than 50 square feet.

The COM pricing applies to one type of cover being used on one style of chair. There is a 5% upcharge for 2 or more fabrics. COM yardage requirements are listed on the next page. This is based on plain 54" material. **Extra fabric is required to match any pattern with matching repeats.** For 54" material with a pattern repeat, increase the COM yardage requirements by the factor shown in the charts below. For geometric patterns or other fabrics with repeats in both directions, add the vertical and horizontal repeats and use the chart below.

Fabric Repeat Pattern Cut Across Roll	Increase COM Requirement by
1" - 5"	10%
6" - 9"	15%
10" - 13"	20%
14" - 20"	25%
21" - 27"	30%
28" - 34"	35%

Fabric Repeat Pattern Cut Up The Roll	Increase COM Requirement by
1" - 5"	15%
6" - 9"	20%
10" - 13"	25%
14" - 20"	30%
21" - 27"	35%
28" - 34"	35%

Fabric Repeat Pattern Cut 2 Way Repeat	Increase COM Requirement by
1" - 5"	15%
6" - 9"	25%
10" - 13"	30%
14" - 20"	35%
21" - 27"	40%
28" - 34"	45%

53-54" Wide - Increase Yardage by 10%
 51-52" Wide - Increase Yardage by 15%
 48-49" Wide - Increase Yardage by 18%
 Under 48" Wide - Consult Customer Support at 800.521.9614

NOTE: When supplying fabric on multiple rolls, please add 2 yards to the total yardage requirement.

Excess COM will not be stored or returned.

YARDAGE REQUIREMENTS

Ithaca Lounge Seating	COM ydg.	COL sq. ft.
IH10001 Lounge Chair	4	72
IH10002 Settee	7	126
IH10004 Sofa	10	180
IH10201 Single Bench	2 1/2	45
IH10202 Double Bench	4	72
IH10203 Triple Bench	5 1/2	99

ITHACA LOUNGE SEATING

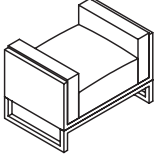
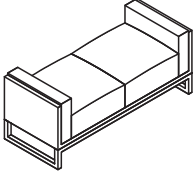
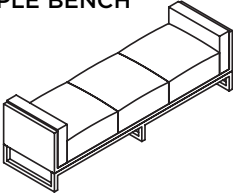
PRODUCT	MODEL #	DESCRIPTION
SINGLE BENCH		
	IH10201	Single Bench - 36"W x 24"D x 25"H
DOUBLE BENCH		
	IH10202	Double Bench - 60"W x 24"D x 25"H
TRIPLE BENCH		
	IH10203	Triple Bench - 84"W x 24"D x 25"H

Lounge seating features a veneer shell, upholstered seat and metal legs. When ordering lounge seating, it is essential you select finishes for each of these three items.

HOW TO ORDER LOUNGE SEATING:

Example: Double Bench; Aluminum Paint; Medium Cherry Veneer; Momentum Infusion Lime Fabric: Grade 5

IH10202 AL C7 09051953 G5

Model Number
Paint Color
Veneer
Fabric Color
Fabric Grade

ITHACA OCCASIONAL TABLES

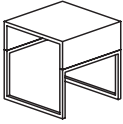
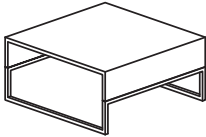
PRODUCT	MODEL #	DESCRIPTION	TABLE HEIGHT
SIDE TABLE OPEN			
 22"W x 22"D TABLE SHOWN	IH10301	Side Table Open - 18"W x 18"D	22"
	IH10302	Side Table Open - 26"W x 18"D	22"
	IH10303	Side Table Open - 22"W x 22"D	22"
COFFEE TABLE OPEN			
 36"W x 36"D TABLE SHOWN	IH10304	Coffee Table Open - 42"W x 24"D	17"
	IH10305	Coffee Table Open - 36"W x 36"D	17"

When ordering Occasional Tables, please remember to choose a veneer finish for the top and a powder paint finish for the base.

HOW TO ORDER OCCASIONAL TABLES:

Example: 24"W x 42"D Coffee Table Open; Raven Paint; Medium Cherry Veneer

IH10304
RN
C7
Model Number
Paint Color
Veneer