

# SAN FRANCISCO CIRCULATION DESK

---



## **The San Francisco Circulation Desk. A new line born of an ergonomic solution.**

Bretford's newest addition, the San Francisco Circulation Desk, is functional and ergonomically designed. The San Francisco Public Library commissioned Kwan Henmi Architecture of San Francisco to create Interior Design Standards that would respond to their functional and aesthetic needs. In addition, Michael J. White, board certified ergonomist and independent consultant, was retained to analyze their librarians' work areas and establish standards for use in designing the most ergonomic library furniture available.

Kwan Henmi and Mike White Consulting collaborated with Bretford to respond to the library's needs resulting in The San Francisco Circulation Desk. Thanks to the diligent engineering efforts and production knowledge of Bretford and creative talents of Kwan Henmi and Mike White, San Francisco librarians now have furniture that enhances the way they work.

Bretford proudly offers the San Francisco Circulation Desk as standard product, available to all customers.

# GENERAL ERGONOMIC CONSIDERATIONS

---

Workshops, interviews and research went into the development of the San Francisco Collection. The collaboration between Mike White Consulting, Kwan Henmi Architecture and Bretford involved in the development of this line has created a unique and exciting system of modular components to allow customization for each library. It is the intention of the collective design team involved with the development of the San Francisco Collection to inspire the highest quality of design execution and we hope you enjoy the flexibility offered.

---

The following ergonomics and workflow improvements, as determined by Mike White, are integrated to support the fit and function of the library staff with their environment. The ergonomic considerations are used to enhance the comfort and efficiency of the staff and to reduce the likelihood of developing a work-related injury. These guidelines were developed in concert with SFPL library administration and branch staff through a series of workshops to identify problems, generate ideas and test ergonomic concepts. The development process also entailed a review of ergonomics best practices and design interventions of dozens of other Library branch systems to determine which had the most influence in reducing ergonomics risk factors and producing desirable posture / motion outcomes. Additionally, the product design takes into account consideration of adopting radio frequency identification (RFID) technologies in the future and the service modules have been designed to address this new technology. For this reason, a fairly conservative approach to ergonomics is proposed to facilitate future change with minimal obsolescence of furniture, fixtures and new electronic equipment, recognizing the ergonomics advantages RFID technology will bring in the near future.

- **Enhance Reach to All Materials**

Anthropometric measurements for a person's functional reach are applied to all horizontal surfaces, vertical storage and staging components. Particular attention is placed on all service counters to ensure that the surface designs allow the staff to reach books, materials and their equipment without posing awkward spine or upper limb postures. A motion arc of 21" about the shoulders is used to determine most counter dimensions / configurations, to optimize people's postures, their motion efficiency and the overall performance within a branch environment with potential space limitations.

- **Maximize the Staff's Ability to Slide Materials**

The library staff often handles thousands of books and media over the day in what is called a "pinch-grip", that is, they lift materials using the two long fingers and the opposing force of the thumb. This posture is very stressful on the muscle / tendon structures of the hand and when performed repetitively, it can pose a risk for developing hand / wrist disorders. This furniture line utilizes the functional reach metrics mentioned above to allow the staff to rake and slide materials on counters with an open hand to reduce the need to grip items. Bins, carts and counters were also designed to enable people to transfer materials between them by sliding loads placed at similar heights. The counter finish materials were selected to minimize friction to enhance sliding of books and media.

- **Accommodate People's Sizes at All Service Points**

Anthropometric benchmarks were applied to determine appropriate height settings for service counters. These include elbow heights for sitting, standing and perching positions to accommodate the greatest range of staff sizes working in these postures. Circulation counters have varied-height counters at 34" and 39" to accommodate the general public and ADA. However, these counters can be utilized by staff for a very small female standing at the 34" counter or a large male perching on a stool at this height. In all staff and service areas we attempted to minimize the use of keyboard trays for height adjustment because of the difficulty they create in reaching items on the primary surface.

- **Minimize Bending and Lifting to Process Materials**

Bending to low book shelves, low tiers on carts, low counters or book bins placed on the floor are arguably one of the most common ergonomics complaints of the library staff. Therefore, all shelving and booktrucks are at such a height that materials can be placed at shin height (10 to 12" up) and above for all components that are frequently used by the staff. In all cases, bins, carts, trucks and counters were selected based on their ability to provide vertical assistance to the operator to minimize bending and lifting.

# ERGONOMIC GUIDELINES

## CIRCULATION COUNTER HEIGHTS

The Circulation counter is fixed at 39" high which is about the standing elbow height of the 50th percentile, or average height, female/male. At this height the greatest segment of the library staff can handle books and use equipment on the counter with neutral back and upper limb postures. To accommodate ADA and children's access on the public side of the counter, a lower height Circulation Module is needed. This standard provides a 34" high lower counter that will allow smaller staff to work in a standing position or anyone of the staff to sit on a stool to work in a "perching" position. For counter work that involves interacting with the public and handling materials, a standing or perching work height is desirable for enhancing a person's ability to reach and maneuver in neutral body positions.

### Special Note:

If smaller branches do not include workstations for the Circulation staff to perform computer and paper work, or, if the staff must spend greater than 2-hour intervals at the counter, consider applying multiple ADA Circulation Modules to allow the staff to perch on stools rather than stand for long periods.

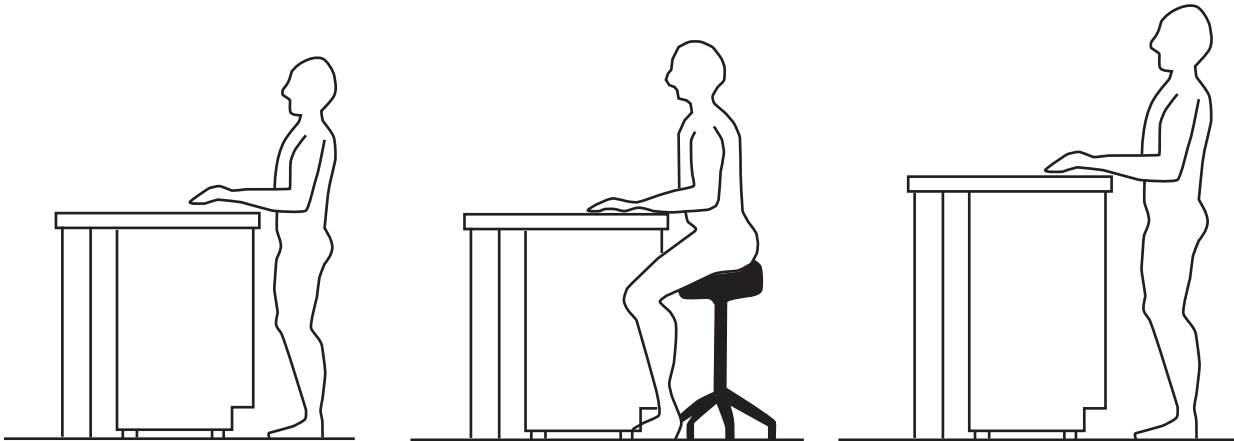

- **ADA Circulation Module**  
- Small size female standing at counter set at 34 inches

- **ADA Circulation Module**  
- Average size female/male perching at counter set at 34 inches

- **Standing Height Circulation Module**  
- Average size female/male standing at counter set at 39 inches

## CIRCULATION COUNTER DESIGNS

The layout of 54"W Circulation Counter Module is 30" deep by 54" wide with a curved "body-pocket" recess at the point of operation of the staff. The depth of the counter at the body-pocket is 21" which is the average reach of the 50% female / male without bending the back or extending the shoulder. The metrics of this design provides ample surface space for equipment and books at each side of the person while allowing them to reach tools and materials placed anywhere on the counter comfortably and efficiently.

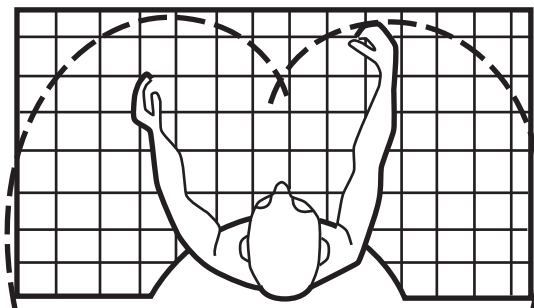

### Circulation Module Work Surface Layout

- 50% female/male reach metric at 21" from body-pocket
- Ample surface space at each side for staging materials

# CIRCULATION DESK COMPONENTS



The San Francisco Circulation Desk's beautiful lines and graceful shape are the perfect center piece for any library.

- The circulation desk has a custom millwork look but is actually a modular system allowing the components to be combined together to create a custom desk.
- Worksurface heights are available in standing and perching which are desirable for enhancing a person's ability to reach and maneuver in neutral body positions.
- The worksurface is available with laminate on MDF in a variety of color options.
- Front panels, end and middle panels and interior components can be finished in any one of Bretford's veneer finishes.
- A variety of internal components can be ordered including shelves, cabinets and file drawers.
- Floor levelers on all pieces adjust to accommodate uneven floors.

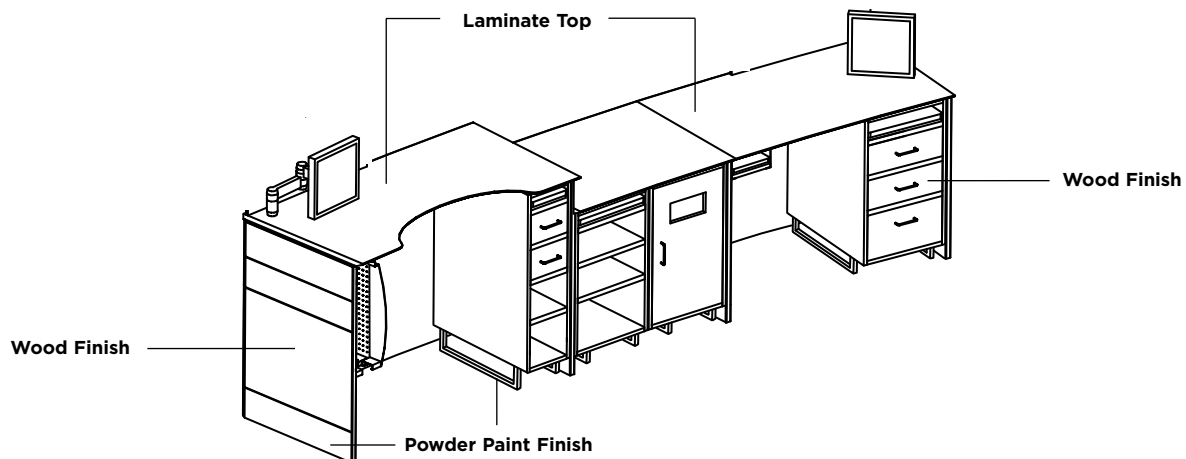

# SPECIFICATION INFORMATION

## CIRCULATION COMPONENTS

Overall height of circulation desks are either 34" or 39". End, Middle and Front panels all measure 1" lower than the overall height to accommodate for the worksurface. The combined height of the panels and worksurfaces equals the overall height listed above.

### Worksurface:

Worksurface is available with laminate on MDF. Laminate on MDF worksurface is constructed of 1/8" thick MDF with a laminate surface laid up on it. The edges of the MDF are left exposed. The edges are finished to match the end panels and front panels giving a continuous look. The staff side of the worksurface has a knife edge while all other edges have a 3mm round over edge. Worksurfaces measure 30"D.

When ordering worksurfaces, many things need to be considered. The first is the shape of the desk. The front edge can be straight or feature a 30' or 50' radius.

The second is the size. Worksurfaces come in 3 different widths: 36", 48" or 54".

54"W worksurfaces can be ordered with a body pocket. A body pocket is a cut out on the staff side of the worksurface. The body pocket allows for the staff member to easily reach across the desk keeping all portions of the desk within reach.

Third, worksurfaces can be ordered with or without grommets. When ordering your worksurface, specify where the grommet should be located from the staff's perspective - left, right, both or none. Grommets are 3" diameter and include a cover. Grommets available in anthracite only.

### End and Middle Panels:

End and Middle Panels are constructed of 1" thick particle board covered on both sides with veneer. End panels can be ordered with or without reveals. Reveals are a 1/4" x 1/4" groove finished with plastic inserts, painted black, which are installed flush with the surface. End and Middle Panels are available in two heights: Perching (32 1/2"H) and Standing (37 1/2"H).

End Panels and Middle Panels include a metal toe kick as well. The toe kick measures 4"H and attaches to the inside of the end panel and on both sides of the middle panel. The toe kick is the structural integrity of the entire desk. It is constructed of 14-gauge steel finished in powder paint. The toe kicks include leveling glides allowing the entire desk to be leveled from the top while the desk is being installed.

Transition panels are available to allow for the desk to change in elevation. One half of the transition panel accommodates a 39"H worksurface. The other half of the panel includes a 1/4" groove through half the panel allowing for a 34"H worksurface to be inserted. The transition panels are constructed the same way as the middle panel.

All connections from toe kick to end and middle panel are metal to metal.

Overall Dimensions: 27 5/8"D x 1"W x 32 1/2"H or 37 1/2"H

### Front Panels:

Front Panels are available in three different styles: 1) Straight, 2) 30' Radius and 3) 50' Radius.

The Straight Front Panels are constructed of 1" thick particle board finished on both sides with veneer. 30' and 50' Radius Front Panels have a balanced construction of 5 layers of bendable plywood finished on both sides with veneer. Front Panels can be ordered with or without reveals. Reveals are a 1/4" x 1/4" plastic inserts, painted black, which are installed flush with the surface. Front Panels are available in two heights: Perching (32 1/2"H) and Standing (37 1/2"H) and three widths: 36"W, 48"W and 54"W. Please be sure to order the front panel that matches the length and shape of the worksurface.

Front Panels also include a toe kick which attaches to the inside of the front panels. The toe kick is constructed of metal and finished in powder paint. The toe kick is recessed 1" on the front panels. The Front Panels attach directly to the End and Middle Panels using metal to metal connections.

Overall Dimensions: 36", 48" or 54"W x 1"D x 32 1/2"H or 37 1/2"H

### Corner Units:

Corner units are ordered using the same philosophy as the rest of the circulation desk. A front panel and corresponding worksurface must be ordered separately. Front panels come with or without reveals. Corner units are designed such that a narrow shelving shell can fit underneath it. Units are available in both straight and curved forms.

## CIRCULATION INTERNAL COMPONENTS AND ACCESSORIES

### Shelf Shell:

The Shelf Shell sides, top and bottom are constructed of 5/8" thick particle board covered on both sides with veneer. The back of the shell is constructed of 18-gauge metal finished in powder paint. The back panel includes several cut outs to allow for cord management.

The Shell stands 4" above the floor on two, 4"H supports. The supports are constructed of 1" square tube bent and welded into a U-shape and topped with a metal plate. The metal supports are finished in powder paint. The metal plate then attaches to the underside of the shelf shell. The metal supports have glides which allow the shell to be easily leveled.

The Shelf Shell can be outfitted with a variety of different shelves and drawers. The interior of the shell has adjustment holes drilled on 32mm centers. This is how all internal components attach to the inside of the shell. The Shell comes in two heights, 33" and 38", and two widths, narrow (11 13/16") and wide (17 13/16"). The narrow shell is designed specifically to be used with the body pocket so that it does not inhibit the use of the body pocket.

The Shelf Shell is independent of the circulation desk. It is not attached to the desk so that it can be easily moved if necessary.

### Wide Shelf Shell:

Overall Dimensions: 17 3/16"W x 23 1/4"D x 32 1/2" H or 37 1/2"H  
Interior Dimensions: 15 7/8"W x 23 1/4"D x 25 3/4"H or 30 3/4"H

### Narrow Shelf Shell:

Overall Dimensions: 11 13/16"W x 23 1/4"D x 32 1/2" H or 37 1/2"H  
Interior Dimensions: 10 1/2"W x 23 1/4"D x 25 3/4"H or 30 3/4"H

# SPECIFICATION INFORMATION

## **Drawer and File Drawer:**

The Drawer and File Drawer fit in to the Shelf Shell. The Drawer and File Drawer are constructed of metal and finished with a wood veneer front. The metal portion of the drawer is constructed of 18-gauge steel and finished with powder paint. The front of the drawer is  $\frac{5}{8}$ " thick particle board covered on both sides with veneer. Drawer pulls are arc shaped and are finished to match the metal portion of the drawers. The Drawer is shallow while the File Drawer is deeper allowing for the use of hanging file folders for storing  $8\frac{1}{2}$ " x 11" paper. The drawers slide easily on Accuride Glides.

It is recommended that the File Drawer only be installed at the very bottom of the Shelf Shell to prevent tipping.

## **Wide Drawer:**

Overall Dimensions:  $15\frac{3}{4}$ "W x  $22\frac{1}{4}$ "D x  $4\frac{15}{16}$ "H

## **Narrow Drawer:**

Overall Dimensions:  $10\frac{3}{8}$ "W x  $22\frac{1}{4}$ "D x  $4\frac{15}{16}$ "H

## **Wide File Drawer:**

Overall Dimensions:  $15\frac{3}{4}$ "W x  $22\frac{1}{2}$ "D x  $10\frac{1}{8}$ "H

## **Narrow File Drawer:**

Overall Dimensions:  $10\frac{3}{8}$ "W x  $22\frac{1}{2}$ "D x  $10\frac{1}{8}$ "H

## **Metal Adjustable Shelf:**

The Metal Adjustable Shelf fits perfectly into the Shelf Shell using collar pins. The shelf is finished in powder paint to resist chipping and scratching. The shelf can be placed anywhere inside the shell and can be moved whenever necessary. The Metal Shelf is available to fit both the wide and narrow Shelf Shell.

## **Wide Metal Adjustable Shelf:**

Overall Dimensions:  $15\frac{3}{4}$ "W x  $22\frac{1}{4}$ "D x  $1\frac{3}{8}$ "H

## **Narrow Metal Adjustable Shelf:**

Overall Dimensions:  $10\frac{3}{8}$ "W x  $22\frac{1}{4}$ "D x  $1\frac{3}{8}$ "H

## **Wood Adjustable Shelf:**

The Wood Adjustable Shelf is constructed of 1" thick particle board covered on both sides with veneer. The Wood Adjustable Shelf is easily installed inside the Shelf Shell. It is installed using collar pins and can readily be rearranged if necessary. The Wood Shelf is available to fit both the wide and narrow Shelf Shell.

## **Wide Wood Adjustable Shelf:**

Overall Dimensions:  $15\frac{3}{4}$ "W x  $22\frac{1}{4}$ "D x 1"H

## **Narrow Wood Adjustable Shelf:**

Overall Dimensions:  $10\frac{3}{8}$ "W x  $22\frac{1}{4}$ "D x  $1\frac{3}{8}$ "H

## **Metal Pull-Out Shelf:**

The Pull-Out Shelf is constructed of metal and attaches directly to the Shelf Shell. The shelf is available to fit both the wide and narrow Shelf Shell.

## **Wide Metal Pull-Out Shelf:**

Overall Dimensions:  $15\frac{3}{4}$ "W x  $22\frac{1}{4}$ "D x 1"H

## **Narrow Metal Pull-Out Shelf:**

Overall Dimensions:  $10\frac{3}{8}$ "W x  $22\frac{1}{4}$ "D x  $1\frac{3}{8}$ "H

## **Worksurface Mounted CPU Holder:**

The Worksurface Mounted CPU holder is constructed of metal and finished with powder paint to resist scratching and chipping. It attaches to the worksurface using wood screws. The CPU Holder is adjustable from  $4\frac{1}{2}$ " to  $11\frac{1}{4}$ " wide. The maximum CPU height is  $18\frac{7}{8}$ ".

## **Modesty Panel Mounted CPU Holder:**

The Modesty Panel Mounted CPU Holder attaches directly to the Modesty Panel. This type of installation is recommended when it is not necessary to constantly reach the CPU. The Holder is constructed of a  $\frac{5}{8}$ " thick wood platform finished on both sides and welded metal brackets finished in powder paint.

Overall Dimensions: 22"W x 12"D

## **Flat Screen Monitor Arm:**

The Flat Screen Monitor Arm supports one flat monitor. It conforms to VESA 75mm and 100mm mounting patterns.

Arm mounts to the work surface with one bolt (provided). One small hole must be drilled into the work surface. It can be installed anywhere on the worksurface. It is constructed of extruded aluminum finished only in aluminum.

The Flat Screen Monitor Arm utilizes a universal mounting bracket that holds the flat panel to the arm. Most flat panels will fit, but contact your screen manufacturer for more information on your specific flat screen model. The maximum weight capacity is 25 pounds per flat screen monitor.

The arm features a single motion, 5-axis point position adjustment. The height adjustment is 14" (+7" to -7"). The arm extension is 22" with an arm rotation of 359 degrees. The bracket arm rotation when a monitor is mounted is 230 degrees. The monitor swivel is 359 degrees and monitor tilt is 180 degrees. The folded depth is 4".

## **Disposal Cabinet Door:**

The Disposal Cabinet works with the Wide or Narrow Shelf Shell. Use this cabinet door to hide the garbage. The cut out in the door allows you to throw items away easily and keeps it hidden. The door is constructed of  $\frac{5}{8}$ " thick particle board covered on both sides with veneer. Includes a matching handle that is painted the same color as the supports of the Shelf Shell. The Disposal Cabinet Door can be ordered with or without a lock.

## **Wide Disposal Cabinet Door:**

Overall Dimensions:  $15\frac{3}{4}$ "W x  $5\frac{5}{8}$ "D x  $25\frac{5}{8}$ "H or  $30\frac{5}{8}$ "H

## **Narrow Disposal Cabinet Door:**

Overall Dimensions:  $10\frac{3}{8}$ "W x  $5\frac{5}{8}$ "D x  $25\frac{5}{8}$ "H or  $30\frac{5}{8}$ "H

---

**Cabinet Door:**

The Cabinet Door works with the Wide or Narrow Shelf Shell. Use this cabinet door to create an enclosed storage space. The door is constructed of  $\frac{5}{8}$ " thick particle board covered on both sides with veneer. Includes a matching handle that is painted the same color as the supports of the Shelf Shell. The Cabinet Door can be ordered with or without a lock.

**Wide Cabinet Door:**

Overall Dimensions:  $15\frac{3}{4}$ "W x  $\frac{5}{8}$ "D x  $25\frac{5}{8}$ "H or  $30\frac{5}{8}$ "H

**Narrow Disposal Cabinet:**

Overall Dimensions:  $10\frac{3}{8}$ "W x  $\frac{5}{8}$ "D x  $25\frac{5}{8}$ "H or  $30\frac{5}{8}$ "H

**Worksurface Mounted Pull-Out Shelf:**

The Worksurface Mounted Pull-Out Shelf is the perfect way to add additional worksurface without adding an entire shelving shell. The Pull-Out Shelf is constructed of metal and particle board. The assembly is metal and attaches directly to underside of the worksurface. The Pull-Out Shelf portion is constructed of particle board covered on both sides with veneer.

Overall Dimensions:  $9\frac{3}{4}$ "W x  $16\frac{1}{8}$ "D x  $4\frac{13}{16}$ "H

**Worksurface Mounted Pencil Drawer:**

The Worksurface Mounted Pencil Drawer is constructed of metal and finished with a wood veneer front. The metal portion of the drawer is constructed of 18-gauge steel and finished with powder paint. The front of the drawer is  $\frac{5}{8}$ " thick particle board covered on both sides with veneer. Drawer pulls are arc shaped and are finished to match the metal portion of the drawers.

Overall Dimensions:  $9\frac{3}{4}$ "W x  $16\frac{1}{8}$ "D x  $4\frac{13}{16}$ "H

**PLEASE NOTE:** Hardwire and Softwire power can be ordered as a custom option. Please contact Bretford's Customer Support Department to inquire about custom power options for your San Francisco Circulation Desk.

# HOW TO ORDER CIRCULATION DESKS

## ORDERING CIRCULATION DESKS

The San Francisco Collection Circulation Desk is a modular desk system. This design feature requires the desk to be ordered as individual components in a build-you-own manner. There are a couple of decisions that need to be made before actually ordering the unit. Those decisions as well as the step-by-step guide on how to order is outlined below.

### STEP 1: DETERMINE SIZE & SHAPE

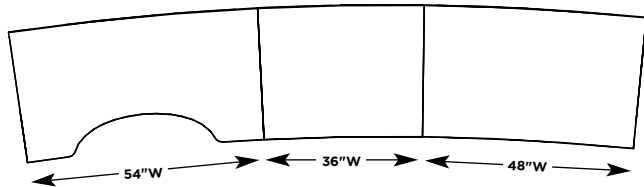

The first step is to determine how large you would like your desk to be. Since the desk components only come in 3 widths (36", 48", 54"), you will need to use a combination of sizes to fit the space you have available.

You then need to determine the shape of the desk using the three shapes available: 30' radius, 50' radius and straight. These shapes can be mixed and matched to create the shape you desire.

### STEP 2: DETERMINE ELEVATION

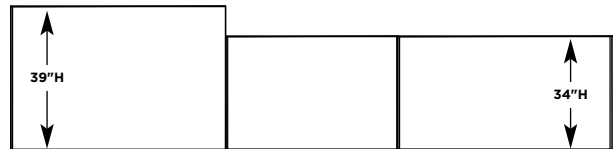

The second step is to determine the elevation of the desk. There are two heights available: 34" and 39". You may interchange these heights throughout your entire desk.

### STEP 3: ORDER END AND MIDDLE PANELS

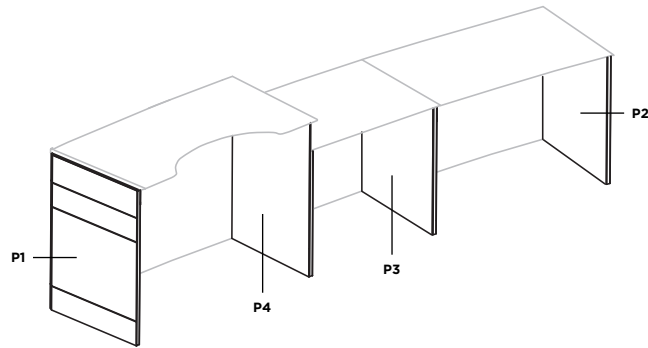

Now it is time to write the order. The end and middle panels are the first items to order. For each entire circulation desk, there will only be two end panels: a left end panel (**P1**) and a right end panel (**P2**). When ordering the circulation desk, order from the staff view as shown above.

When ordering end panels, you must also decide if you want reveals or not. It is at this time that you would specify reveals as well as when ordering front panels.

Ordering middle panels is just as simple. Order a standard middle panel (**P3**) based on the height of the desk or a transition panel (**P4**) if the desk is shifting from one height to another.

### STEP 4: ORDER FRONT PANELS

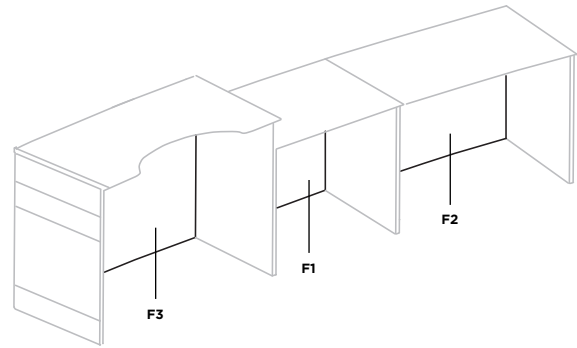

Ordering front panels is the time you begin creating the shape and size of your circulation desk. Front panels are available in three widths: 36" (**F1**), 48" (**F2**) and 54" (**F3**). They are also available in three shapes: 30' radius, 50' radius and straight. Each of these items need to be kept in mind when ordering front panels. If you have decided to have reveals on your desk and have ordered them with your end panels, you will need to order them with your front panels as well so the entire unit matches.

In addition, the height of the front panels should be the same as its neighboring end and middle panels.



## STEP 5: ORDER WORKSURFACES

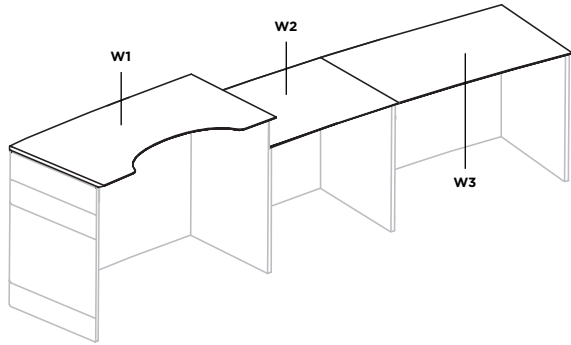

To complete your circulation desk, you must order your worksurfaces. Each worksurface has ultimately been decided for you based on the front panels you selected. The same considerations need to be made for worksurfaces as front panels including the width and shape.

Just like the front panels, worksurfaces come in three widths: 36", 48" and 54". Please note, only the 54"W unit can be ordered with a body pocket (**W1**). In addition, they come in three shapes: 30' radius, 50' radius and straight.

The most critical aspect to remember when ordering worksurfaces is each worksurfaces' relationship to the overall circulation desk. Because the relationship is crucial to the desk fitting together properly, there are four different ways each worksurface can be ordered to accomplish creating the desk you want. The four types

of worksurfaces are left extension, right extension, both side extension and same height both sides. These descriptions relate to how the worksurface is placed on the end and middle panels.

- When a worksurface sits alone (not touching another worksurface), it has both sides extended over the full thickness of the panels and therefore is a "Both Side Extension" worksurface (**W1**).
- When a worksurface butts up to another worksurface, requiring them to share a middle panel, or the worksurface meets up with the lower side of a transition panel, there is no extension on either side of the worksurface and therefore is a "No Side Extension" worksurface (**W2**).
- When a worksurface butts up against another worksurface on one side, thus sharing a middle panel, and extends out over the entire thickness of the upright panel on the other side, it is a "Right Side Extension" (**W3**) or "Left Side Extension" worksurface depending on which side the worksurface uses the entire thickness for support.

One final consideration are grommet holes. When ordering your worksurfaces, you may choose to have grommets or not. You may also select whether you want grommets on the right side, left side, both sides or none at all.

## ORDERING CIRCULATION DESKS

Below is the actual order for the circulation desk explained on the previous pages. Each piece is numbered to match the description listed in each step. The easiest way to order a complete circulation desk is to go from left to right from the staff side of the desk as shown.

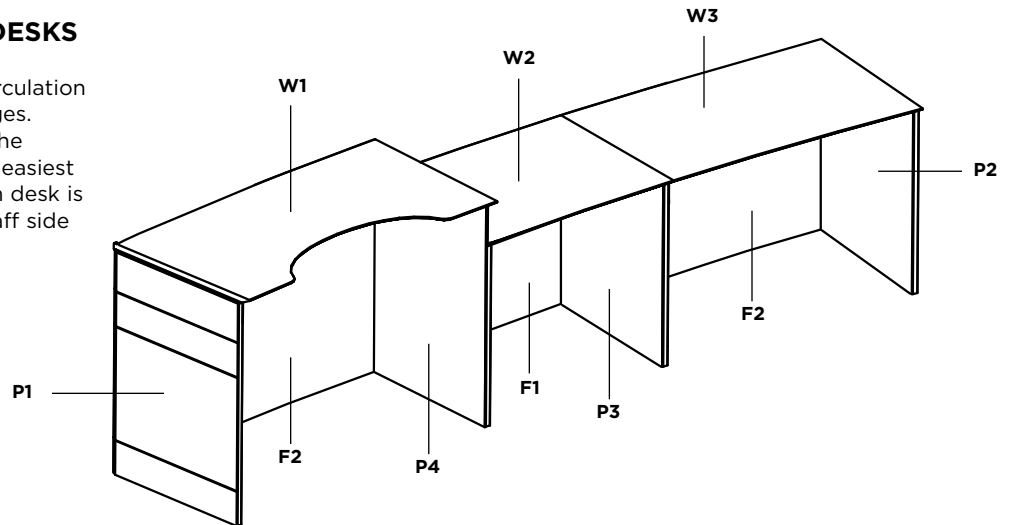

	Model Number	Description
<b>P1</b>	CBPLSV	Left End Panel w/Reveals- 38"H
<b>F2</b>	CBF554SV	Front Panel, 50' Radius w/Reveals, 54"W, 38"H
<b>W1</b>	CBWB554BPN	Worksurface, Both Side Extension, 50' Radius, 54"W, w/Body Pocket, No Grommets
<b>P4</b>	CBPTSP	Transition Middle Panel, 38"H Left Side & 33"H Right Side
<b>F1</b>	CBF536PV	Front Panel, 50' Radius w/Reveals, 36"W, 33"H
<b>W2</b>	CBWE536N	Worksurface, No Side Extension, 50' Radius, 36"W, No Grommets
<b>P3</b>	CBPMP	Middle Panel, 33"H
<b>F2</b>	CBF554PV	Front Panel, 50' Radius w/Reveals, 48"W, 33"H
<b>W3</b>	CBWR554	Worksurface, Right Side Extension, 50' Radius, 48"W, No Grommets
<b>P2</b>	CBPRPV	Right End Panel w/Reveals, 33"H

# HOW TO ORDER CIRCULATION DESKS

## ORDERING CIRCULATION DESK ACCESSORIES

Now that you have your desk specified, it is time to add accessories. Several accessories can be ordered by using just one model number. All of the under-counter shelving and drawers can be configured to hold a variety of different shelving and drawer types. Because of this, the shelving/filing components are done in a build-your-own format. See the example below for an explanation.

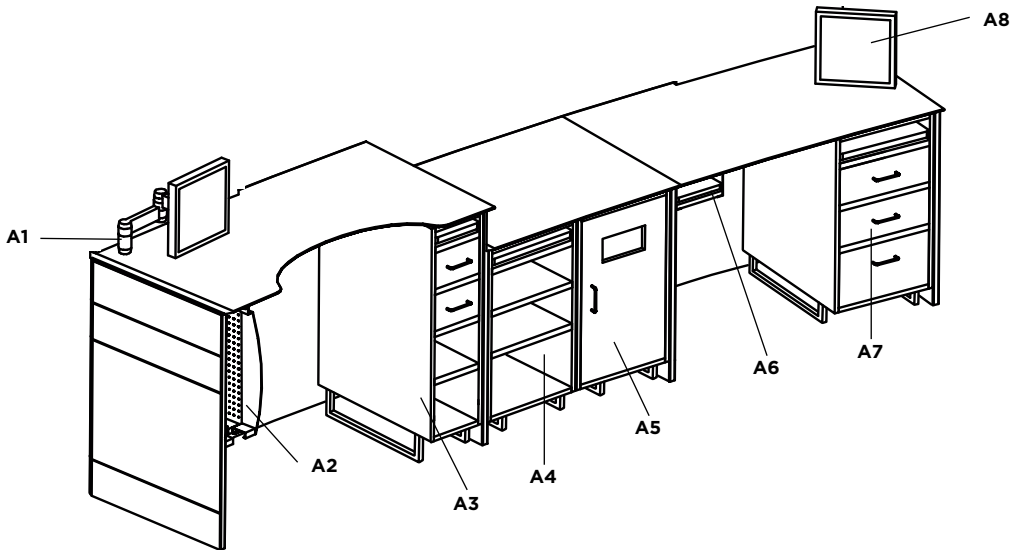

Model Number	Description
<b>A1</b> FPSM-D-ADJ2-AL	LCD Arm
<b>A2</b> CBPTWR	CPU Holder - for attachment under work surface
<b>A3</b> CBSNS CBSON CBSDN CBSDN CBSMN	Shelf Shell, Narrow - 38"H Pull-Out Shelf, Narrow Drawer, Narrow Drawer, Narrow Metal Adjustable Shelf, Narrow
<b>A4</b> CBSWP CBSOW CBSMW CBSMW	Shelf Shell, Wide - 33"H Pull-Out Shelf, Wide Metal Adjustable Shelf, Wide Metal Adjustable Shelf, Wide
<b>A5</b> CBSWP CBSCCW	Shelf Shell, Wide - 33"H Disposal Cabinet
<b>A6</b> CBSOSN	Worksurface Mounted Pull-Out Shelf w/Open Slot, Narrow
<b>A7</b> CBSWP CBSOW CBSDW CBSDW CBSFW	Shelf Shell, Wide - 33"H Pull-Out Shelf, Wide Drawer, Wide Drawer, Wide File Drawer, Wide
<b>A8</b> FPSM-D-ADJ2-AL	LCD Arm

## ANATOMY OF CURVED CIRCULATION DESKS

The diagram below shows the arc created by the two radius styles of circulation components. The top worksurface represents the curve created when using 50' radius worksurfaces. The bottom worksurface represents 30' radius worksurfaces. As you can see by this diagram, a 30' radius worksurface creates a more dramatic curve than the 50' radius worksurface.

**REMINDER:** You can interchange worksurface shapes to create you custom desk shape.

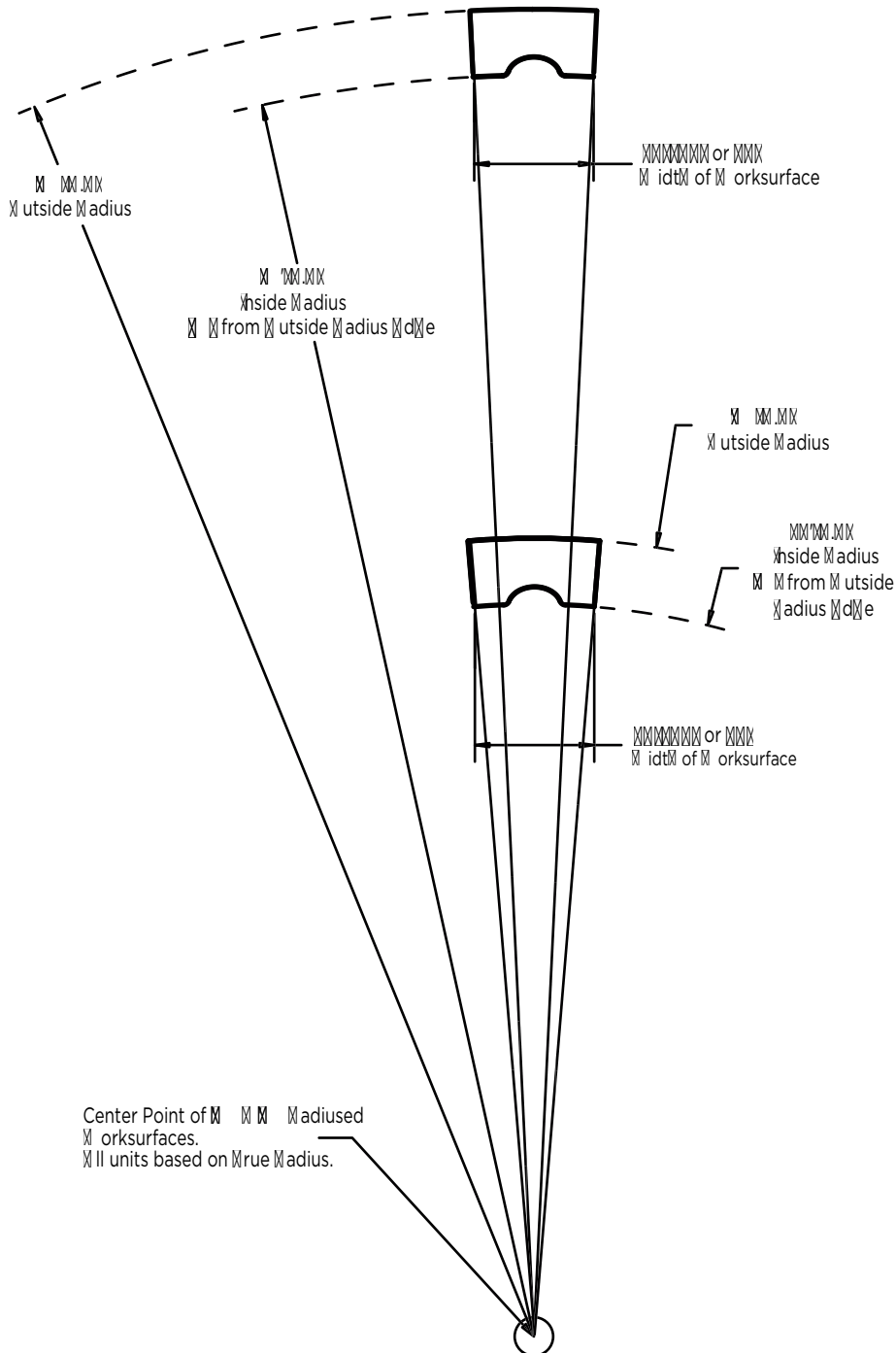

# CIRCULATION DESK COMPONENTS - UPRIGHT PANELS

PRODUCT	MODEL #	DESCRIPTION
---------	---------	-------------

## LEFT END PANEL

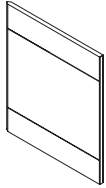

SHOWN PERCHING HEIGHT WITH REVEALS

CBPLP-__	Perching Height End Panel - 33"H
CBPLS -__	Standing Height End Panel - 38"H

## RIGHT END PANEL

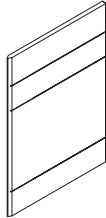

SHOWN STANDING HEIGHT WITH REVEALS

CBPRP-__	Perching Height End Panel - 33"H
CBPRS-__	Standing Height End Panel - 38"H

## MIDDLE PANEL

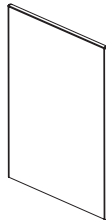

SHOWN STANDING HEIGHT

CBPMP-__	Perching Height Middle Panel - 33"H
CBPMS-__	Standing Height Middle Panel - 38"H

## TRANSITION PANEL

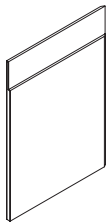

SHOWN 38"H LEFT SIDE/  
33"H RIGHT SIDE

CBTPS-__	Transition Panel - 33"H Left Side & 38"H Right Side
CBTSP-__	Transition Panel - 38"H Left Side & 33"H Right Side

When ordering End and Middle Panels, it is essential that you keep in mind where the panel is located in relationship to the rest of the desk and how tall you wish that particular section of desk to be.

You will only have one Left End Panel and one Right End Panel for each continuous run circulation desk. All other sections of the desk will require a middle or transition panel.

If you wish to have reveals, you only need to order them with end panels. Middle Panels and Transition Panels do not have reveals.

Use Transition Panels when you are changing from one worksurface height to another worksurface height.

### HOW TO ORDER UPRIGHT PANELS:

Example: Right Standing Height End Panel with Reveals; Raven Paint; Medium Cherry Veneer

CBPRS V RN C7

Model Number    Reveal (V) or No Reveal (A)    Paint Color    Veneer

# CIRCULATION DESK COMPONENTS - FRONT PANELS

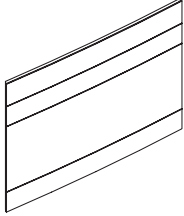
PRODUCT	MODEL #	DESCRIPTION
<b>30' RADIUS CURVE - FRONT PANEL</b> 	CBF336P-__	36"W Front Panel - Perching Height 33"H
	CBF336S-__	36"W Front Panel - Standing Height 38"H
	CBF348P-__	48"W Front Panel - Perching Height 33"H
	CBF348S-__	48"W Front Panel - Standing Height 38"H
	CBF354P-__	54"W Front Panel - Perching Height 33"H
	CBF354S-__	54"W Front Panel - Standing Height 38"H

SHOWN 54"W STANDING HEIGHT WITH REVEALS

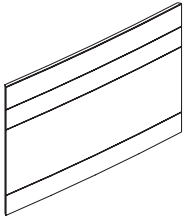
<b>50' RADIUS CURVE - FRONT PANEL</b> 	CBF536P-__	36"W Front Panel - Perching Height 33"H
	CBF536S-__	36"W Front Panel - Standing Height 38"H
	CBF548P-__	48"W Front Panel - Perching Height 33"H
	CBF548S-__	48"W Front Panel - Standing Height 38"H
	CBF554P-__	54"W Front Panel - Perching Height 33"H
	CBF554S-__	54"W Front Panel - Standing Height 38"H

SHOWN 54"W STANDING HEIGHT WITH REVEALS

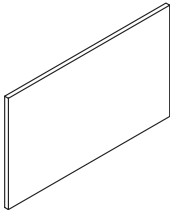
<b>STRAIGHT FRONT PANEL</b> 	CBFS36P-__	36"W Front Panel - Perching Height 33"H
	CBFS36S-__	36"W Front Panel - Standing Height 38"H
	CBFS48P-__	48"W Front Panel - Perching Height 33"H
	CBFS48S-__	48"W Front Panel - Standing Height 38"H
	CBFS54P-__	54"W Front Panel - Perching Height 33"H
	CBFS54S-__	54"W Front Panel - Standing Height 38"H

SHOWN 54"W PERCHING HEIGHT

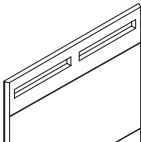
<b>STRAIGHT FRONT PANEL WITH BOOK DROP SLOTS</b> 	CBFS36SBD-__	36"W Front Panel - Standing Height 38"H with 2 Book Drop Slots
	CBFS48SBD-__	48"W Front Panel - Standing Height 38"H with 2 Book Drop Slots
	CBFS54SBD-__	54"W Front Panel - Standing Height 38"H with 3 Book Drop Slots

SHOWN 48"W WITH REVEALS

There are four different types of front panels. When selecting front panels, keep in mind how wide and how high you want your desk. Your front panel height must be the same height as your corresponding end and middle panels.

You can mix and match the type of front panels you select within one circulation desk. For example, you may want the first two sections of your desk to be straight and the remaining three sections to have a 50' radius. However, it is imperative that the corresponding worksurface you choose matches the shape of the front panel you select.

If you decide to have reveals in your end panels, be sure to order reveals in your front panels as well.

## HOW TO ORDER FRONT PANELS:

Example: 54"W Front Panel Standing Height with 50' Radius and Reveals; Raven Paint; Medium Cherry Veneer

CBF554S
V
RN
C7

Model Number
Reveal (V) or No Reveal (A)
Paint Color
Veneer

# CIRCULATION DESK COMPONENTS - 30' RADIUS WORKSURFACES

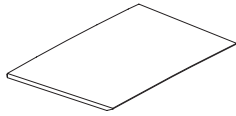
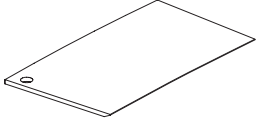
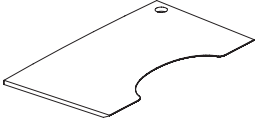
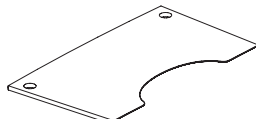
PRODUCT	MODEL #	DESCRIPTION
<b>30' RADIUS CURVE - NO SIDE EXTENSION</b>  SHOWN WITH NO GROMMETS	CBWE336-__	36"W Worksurface A=36", B=39 <sup>1</sup> / <sub>4</sub> "
	CBWE348-__	48"W Worksurface A=48", B=52 <sup>3</sup> / <sub>8</sub> "
	CBWE354-__	54"W Worksurface A=54", B=58 <sup>7</sup> / <sub>8</sub> "
	CBWE354BP-__	54"W Worksurface with Body Pocket A=54", B=58 <sup>7</sup> / <sub>8</sub> "
<b>30' RADIUS CURVE - LEFT SIDE EXTENSION</b>  SHOWN WITH LEFT GROMMET	CBWL336-__	36"W Worksurface A=36 <sup>11</sup> / <sub>16</sub> ", B=40"
	CBWL348-__	48"W Worksurface A=48 <sup>11</sup> / <sub>16</sub> ", B=53 <sup>1</sup> / <sub>16</sub> "
	CBWL354-__	54"W Worksurface A=54 <sup>11</sup> / <sub>16</sub> ", B=59 <sup>5</sup> / <sub>8</sub> "
	CBWL354BP-__	54"W Worksurface with Body Pocket A=54 <sup>11</sup> / <sub>16</sub> ", B=59 <sup>5</sup> / <sub>8</sub> "
<b>30' RADIUS CURVE - RIGHT SIDE EXTENSION</b>  SHOWN WITH BODY POCKET AND RIGHT GROMMET	CBWR336-__	36"W Worksurface A=36 <sup>11</sup> / <sub>16</sub> ", B=40"
	CBWR348-__	48"W Worksurface A=48 <sup>11</sup> / <sub>16</sub> ", B=53 <sup>1</sup> / <sub>16</sub> "
	CBWR354-__	54"W Worksurface A=54 <sup>11</sup> / <sub>16</sub> ", B=59 <sup>5</sup> / <sub>8</sub> "
	CBWR354BP-__	54"W Worksurface with Body Pocket A=54 <sup>11</sup> / <sub>16</sub> ", B=59 <sup>5</sup> / <sub>8</sub> "
<b>30' RADIUS CURVE - BOTH SIDE EXTENSION</b>  SHOWN WITH BODY POCKET AND GROMMETS	CBWB336 -__	36"W Worksurface A=37 <sup>5</sup> / <sub>16</sub> ", B=40 <sup>11</sup> / <sub>16</sub> "
	CBWB348-__	48"W Worksurface A=49 <sup>5</sup> / <sub>16</sub> ", B=53 <sup>3</sup> / <sub>4</sub> "
	CBWB354-__	54"W Worksurface A=55 <sup>5</sup> / <sub>16</sub> ", B=60 <sup>5</sup> / <sub>16</sub> "
	CBWB354BP-__	54"W Worksurface with Body Pocket A=55 <sup>5</sup> / <sub>16</sub> ", B=60 <sup>5</sup> / <sub>16</sub> "

The most crucial aspect of ordering worksurfaces is to make sure they match the shape and width of the corresponding front panel. In addition, you need to know how the worksurface fits into the rest of the desk. See the diagram on the facing page to understand which worksurface you need to order based on where the worksurface fits into the unit.

At this time you need to decide what type of laminate and whether or not you want grommets. All of these choices must be reflected in your model number for the worksurface (see example below).

### DIMENSION KEY

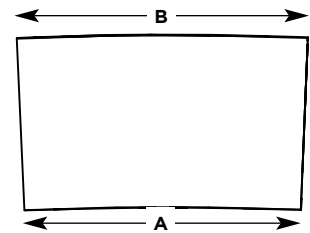

### HOW TO ORDER 30' RADIUS WORKSURFACES:

Example: 30' Radius Curve Worksurface 54"W Same Height Both Sides  
No Grommets; Charcoal Essence Laminate; Medium Cherry Stain

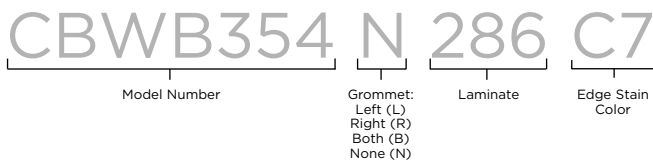

# CIRCULATION DESK COMPONENTS - 50' RADIUS WORKSURFACES

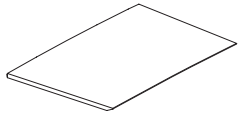
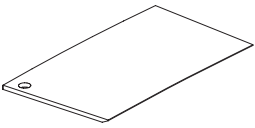
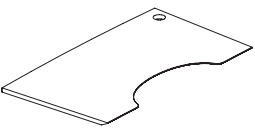
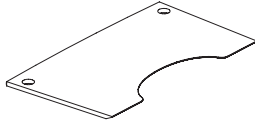
PRODUCT	MODEL #	DESCRIPTION
<b>50' RADIUS CURVE - NO SIDE EXTENSION</b>    SHOWN WITH NO GROMMETS	CBWE536-__	36"W Worksurface A=36", B=37 <sup>7</sup> / <sub>8</sub> "
	CBWE548-__	48"W Worksurface A=48", B=50 <sup>1</sup> / <sub>2</sub> "
	CBWE554-__	54"W Worksurface A=54", B=56 <sup>7</sup> / <sub>8</sub> "
	CBWE554BP-__	54"W Worksurface with Body Pocket A=54", B=56 <sup>7</sup> / <sub>8</sub> "
<b>50' RADIUS CURVE - LEFT SIDE EXTENSION</b>    SHOWN WITH LEFT GROMMET	CBWL536-__	36"W Worksurface A=36 <sup>5</sup> / <sub>8</sub> ", B=38 <sup>9</sup> / <sub>16</sub> "
	CBWL548-__	48"W Worksurface A=48 <sup>5</sup> / <sub>8</sub> ", B=51 <sup>1</sup> / <sub>4</sub> "
	CBWL554-__	54"W Worksurface A=54 <sup>5</sup> / <sub>8</sub> ", B=57 <sup>1</sup> / <sub>2</sub> "
	CBWL554BP-__	54"W Worksurface with Body Pocket A=54 <sup>5</sup> / <sub>8</sub> ", B=57 <sup>1</sup> / <sub>2</sub> "
<b>50' RADIUS CURVE - RIGHT SIDE EXTENSION</b>    SHOWN WITH BODY POCKET AND RIGHT GROMMET	CBWR536-__	36"W Worksurface A=36 <sup>5</sup> / <sub>8</sub> ", B=38 <sup>9</sup> / <sub>16</sub> "
	CBWR548-__	48"W Worksurface A=48 <sup>5</sup> / <sub>8</sub> ", B=51 <sup>1</sup> / <sub>4</sub> "
	CBWR554-__	54"W Worksurface A=54 <sup>5</sup> / <sub>8</sub> ", B=57 <sup>1</sup> / <sub>2</sub> "
	CBWR554BP-__	54"W Worksurface with Body Pocket A=54 <sup>5</sup> / <sub>8</sub> ", B=57 <sup>1</sup> / <sub>2</sub> "
<b>50' RADIUS CURVE - BOTH SIDE EXTENSION</b>    SHOWN WITH BODY POCKET AND GROMMETS	CBWB536-__	36"W Worksurface A=37 <sup>5</sup> / <sub>16</sub> ", B=39 <sup>1</sup> / <sub>4</sub> "
	CBWB548-__	48"W Worksurface A=49 <sup>5</sup> / <sub>16</sub> ", B=51 <sup>7</sup> / <sub>8</sub> "
	CBWB554-__	54"W Worksurface A=55 <sup>5</sup> / <sub>16</sub> ", B=58 <sup>1</sup> / <sub>4</sub> "
	CBWB554BP-__	54"W Worksurface with Body Pocket A=55 <sup>5</sup> / <sub>16</sub> ", B=58 <sup>1</sup> / <sub>4</sub> "

The most crucial aspect of ordering worksurfaces is to make sure they match the shape and width of the corresponding front panel. In addition, you need to know how the worksurface fits into the rest of the desk. See the diagram below to understand which worksurface you need to order based on where the worksurface fits into the unit.

At this time you need to decide what type of laminate and whether or not you want grommets. All of these choices must be reflected in your model number for the worksurface (see example on facing page).

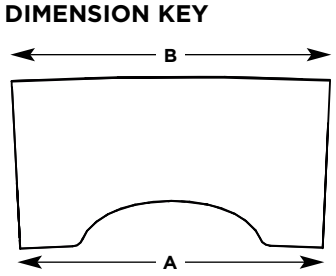

## HOW TO ORDER YOUR WORKSURFACE

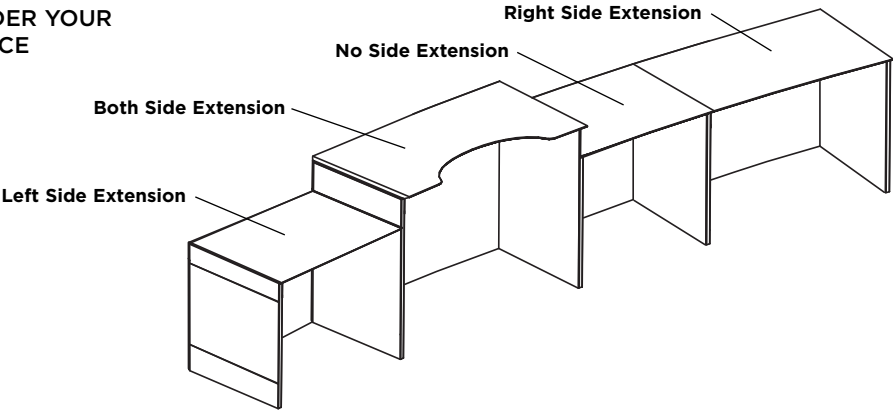

# CIRCULATION DESK COMPONENTS - STRAIGHT WORKSURFACES

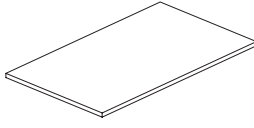
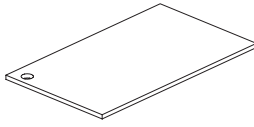
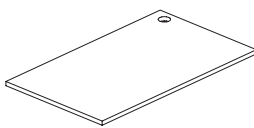
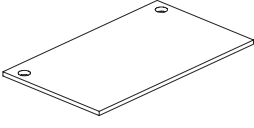
PRODUCT	MODEL #	DESCRIPTION
<b>STRAIGHT - NO SIDE EXTENSION</b>		
 <p>SHOWN WITHOUT GROMMETS</p>	CBWES36-__	36"W Worksurface - A=36"
	CBWES48-__	48"W Worksurface - A=48"
	CBWES54-__	54"W Worksurface - A=54"
	CBWES54BP-__	54"W Worksurface with Body Pocket - A=54"
<b>STRAIGHT - LEFT SIDE EXTENSION</b>		
 <p>SHOWN WITH LEFT GROMMET</p>	CBWLS36-__	36"W Worksurface - A=36 <sup>5</sup> / <sub>8</sub> "
	CBWLS48-__	48"W Worksurface - A=48 <sup>5</sup> / <sub>8</sub> "
	CBWLS54-__	54"W Worksurface - A=54 <sup>5</sup> / <sub>8</sub> "
	CBWLS54BP-__	54"W Worksurface with Body Pocket - A=54 <sup>5</sup> / <sub>8</sub> "
<b>STRAIGHT - RIGHT SIDE EXTENSION</b>		
 <p>SHOWN WITH RIGHT GROMMET</p>	CBWRS36-__	36"W Worksurface - A=36 <sup>5</sup> / <sub>8</sub> "
	CBWRS48-__	48"W Worksurface - A=48 <sup>5</sup> / <sub>8</sub> "
	CBWRS54-__	54"W Worksurface - A=54 <sup>5</sup> / <sub>8</sub> "
	CBWRS54BP-__	54"W Worksurface with Body Pocket - A=54 <sup>5</sup> / <sub>8</sub> "
<b>STRAIGHT - BOTH SIDE EXTENSION</b>		
 <p>SHOWN WITH GROMMETS</p>	CBWBS36-__	36"W Worksurface - A=37 <sup>5</sup> / <sub>16</sub> "
	CBWBS48-__	48"W Worksurface - A=49 <sup>5</sup> / <sub>16</sub> "
	CBWBS54-__	54"W Worksurface - A=55 <sup>5</sup> / <sub>16</sub> "
	CBWBS54BP-__	54"W Worksurface with Body Pocket - A=55 <sup>5</sup> / <sub>16</sub> "

The most crucial aspect of ordering worksurfaces is to make sure they match the shape and width of the corresponding front panel. In addition, you need to know how the worksurface fits into the rest of the desk. See the diagram on the previous page to understand which worksurface you need to order based on where the worksurface fits into the unit.

At this time you need to decide what type of laminate and whether or not you want grommets. All of these choices must be reflected in your model number for the worksurface (see example below).

## ACTUAL DIMENSION KEY

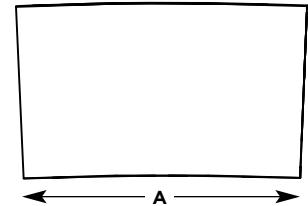

### HOW TO ORDER STRAIGHT WORKSURFACES:

Example: Straight Worksurface 36"W Both Side Extension Both Grommets; Charcoal Essence Laminate; Medium Cherry Stain

CBWBS36	B	286	C7
Model Number	Grommet: Left (L) Right (R) Both (B) None (N)	Laminate	Edge Stain Color



# EXAMPLES - CORNER UNITS

## EXAMPLES OF CORNER UNITS

Bretford offers a variety of corner options for your circulation desk. Each corner unit is designed to provide storage space below it rather than creating unusable space.

Below are diagrams of four different corner unit options. As you can see in the bottom two diagrams, a shelving shell has been placed to create additional storage.

Corner units are ordered using the same philosophy as the rest of the circulation desk. A front panel and corresponding worksurface must be ordered separately. The upright panels for the corner units are shared with the rest of the desk. The shelving shell and shell components are ordered separately as well.

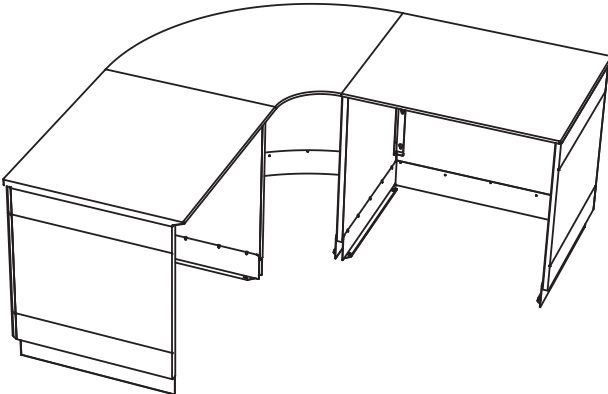

**90° CURVED CORNER UNIT**

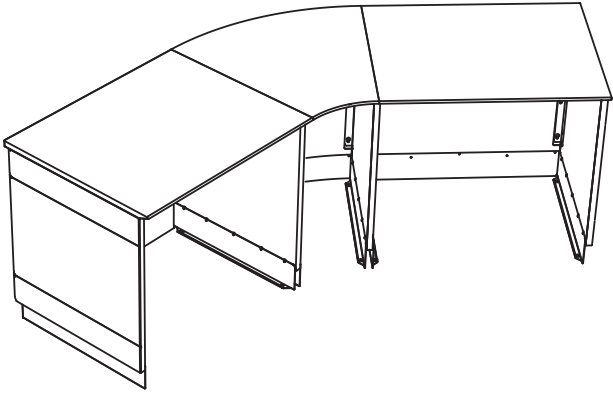

**45° CURVED CORNER UNIT**

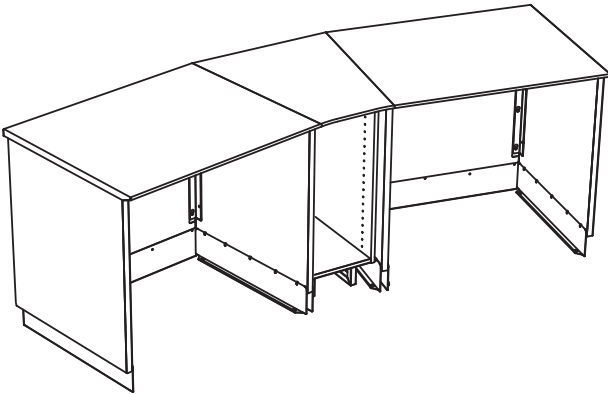

**22 1/2° STRAIGHT CORNER UNIT  
SHOWN WITH A SHELVING SHELL**

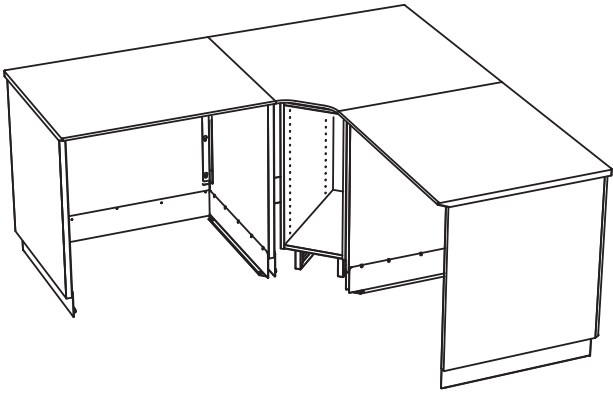

**90° STRAIGHT CORNER UNIT  
SHOWN WITH A SHELVING SHELL**

# CIRCULATION DESK COMPONENTS - CORNER FRONT PANELS

PRODUCT                      MODEL #                      DESCRIPTION

## 22 1/2° STRAIGHT CORNER FRONT PANEL

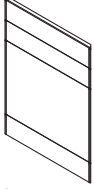

SHOWN STANDING HEIGHT WITH REVEALS

CBF22SP-\_\_      22-1/2° Straight Front Panel - Perching Height 33"H  
 CBF22SS-\_\_      22-1/2° Straight Front Panel - Standing Height 38"H

## 22 1/2° CURVED CORNER FRONT PANEL

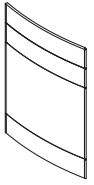

SHOWN STANDING HEIGHT WITH REVEALS

CBF22CP-\_\_      22-1/2° Curved Front Panel - Perching Height 33"H  
 CBF22CS-\_\_      22-1/2° Curved Front Panel - Standing Height 38"H

## 45° STRAIGHT CORNER FRONT PANEL

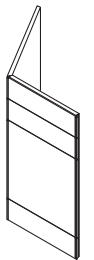

SHOWN STANDING HEIGHT WITH REVEALS

CBF45SP-\_\_      45° Straight Front Panel - Perching Height 33"H  
 CBF45SS-\_\_      45° Straight Front Panel - Standing Height 38"H

## 45° CURVED CORNER FRONT PANEL

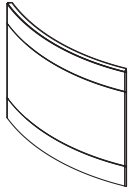

SHOWN PERCHING HEIGHT WITH REVEALS

CBF45CP-\_\_      45° Curved Front Panel - Perching Height 33"H  
 CBF45CS-\_\_      45° Curved Front Panel - Standing Height 38"H

Corner Unit front panels are identical to the circulation desk front panels. When selecting them, keep in mind the corner unit shape you want and how high you want your corner unit to be. Your front panel height must be the same height as your corresponding upright panels.

If you decide to have reveals in your end panels, be sure to order reveals in your front panels as well.

### HOW TO ORDER FRONT PANELS:

Example: 45° Curved Corner Front Panel Standing Height with Reveals; Raven Paint; Medium Cherry Veneer

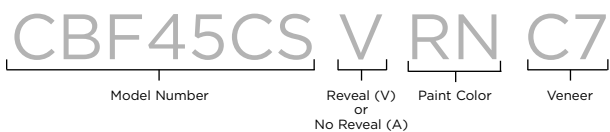

# CIRCULATION DESK COMPONENTS - CORNER FRONT PANELS

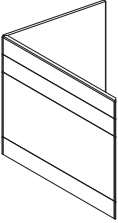
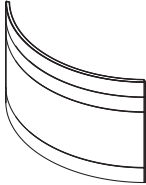
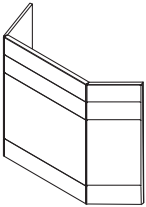
PRODUCT	MODEL #	DESCRIPTION
<b>90° SQUARE CORNER FRONT PANEL</b>		
 <p>SHOWN STANDING HEIGHT WITH REVEALS</p>	CBF90SP-__	90° Square Front Panel - Perching Height 33"H
	CBF90SS-__	90° Square Front Panel - Standing Height 38"H
<b>90° CURVED CORNER FRONT PANEL</b>		
 <p>SHOWN STANDING HEIGHT WITH REVEALS</p>	CBF90CP-__	90° Curved Front Panel - Perching Height 33"H
	CBF90CS-__	90° Curved Front Panel - Standing Height 38"H
<b>90° HEXAGONAL CORNER FRONT PANEL</b>		
 <p>SHOWN STANDING HEIGHT WITH REVEALS</p>	CBF90HP-__	90° Hexagonal Front Panel - Perching Height 33"H
	CBF90HS-__	90° Hexagonal Front Panel - Standing Height 38"H

Corner Unit front panels are identical to the circulation desk front panels. When selecting them, keep in mind the corner unit shape you want and how high you want your corner unit to be. Your front panel height must be the same height as your corresponding upright panels.

If you decide to have reveals in your end panels, be sure to order reveals in your front panels as well.

## HOW TO ORDER FRONT PANELS:

Example: 90° Hexagonal Corner Front Panel Standing Height with Reveals; Raven Paint; Medium Cherry Veneer

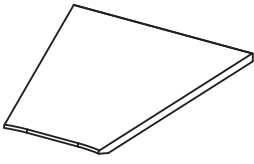

# CIRCULATION DESK COMPONENTS - CORNER WORKSURFACES

PRODUCT	MODEL #	DESCRIPTION
<b>22<sup>1</sup>/<sub>2</sub>° STRAIGHT CORNER WORKSURFACE</b> 	CBWES22-__	22-1/2° Straight Worksurface No Side Extension A=13 <sup>1</sup> / <sub>16</sub> " , B=24 <sup>3</sup> / <sub>4</sub> "
	CBWLS22-__	22-1/2° Straight Worksurface Left Side Extension A=13 <sup>3</sup> / <sub>4</sub> " , B=25 <sup>3</sup> / <sub>8</sub> "
	CBWRS22-__	22-1/2° Straight Worksurface Right Side Extension A=13 <sup>3</sup> / <sub>4</sub> " , B=25 <sup>3</sup> / <sub>8</sub> "
	CBWBS22-__	22-1/2° Straight Worksurface Both Side Extension A=14 <sup>3</sup> / <sub>8</sub> " , B=26"

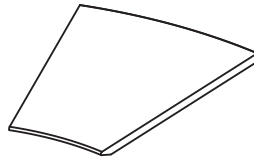
<b>22<sup>1</sup>/<sub>2</sub>° CURVED CORNER WORKSURFACE</b> 	CBWEC22-__	22-1/2° Curved Worksurface No Side Extension A=12 <sup>1</sup> / <sub>2</sub> " , B=24 <sup>3</sup> / <sub>16</sub> "
	CBWLC22-__	22-1/2° Curved Worksurface Left Side Extension A=13 <sup>3</sup> / <sub>16</sub> " , B=24 <sup>13</sup> / <sub>16</sub> "
	CBWRC22-__	22-1/2° Curved Worksurface Right Side Extension A=13 <sup>3</sup> / <sub>16</sub> " , B=24 <sup>13</sup> / <sub>16</sub> "
	CBWBC22-__	22-1/2° Curved Worksurface Both Side Extension A=13 <sup>7</sup> / <sub>8</sub> " , B=25 <sup>7</sup> / <sub>16</sub> "

The most crucial aspect of ordering worksurfaces is to make sure they match the shape and width of the corresponding front panel. In addition, you need to know how the work surface fits into the rest of the desk. See the diagram on page 35 to understand which work surface you need to order based on where the work surface fits into the unit.

At this time you need to decide what type of laminate you want. This choice must be reflected in your model number for the work surface (see example below).

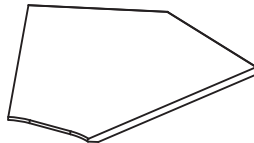
<b>45° STRAIGHT CORNER WORKSURFACE</b> 	CBWES45-__	45° Straight Worksurface No Side Extension A=12 <sup>1</sup> / <sub>4</sub> " , B=35 <sup>3</sup> / <sub>16</sub> "
	CBWLS45-__	45° Straight Worksurface Left Side Extension A=12 <sup>3</sup> / <sub>4</sub> " , B=35 <sup>3</sup> / <sub>4</sub> "
	CBWRS45-__	45° Straight Worksurface Right Side Extension A=12 <sup>3</sup> / <sub>4</sub> " , B=35 <sup>3</sup> / <sub>4</sub> "
	CBWBS45-__	45° Straight Worksurface Both Side Extension A=13 <sup>5</sup> / <sub>16</sub> " , B=36 <sup>5</sup> / <sub>16</sub> "

## DIMENSION KEY

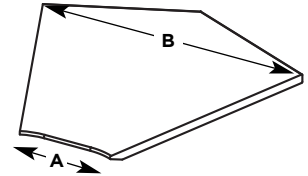

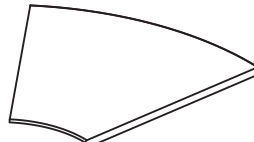
<b>45° CURVED CORNER WORKSURFACE</b> 	CBWEC45-__	45° Curved Worksurface No Side Extension A=11 <sup>1</sup> / <sub>5</sub> " , B=34 <sup>7</sup> / <sub>16</sub> "
	CBWLC45-__	45° Curved Worksurface Left Side Extension A=12- <sup>1</sup> / <sub>8</sub> " , B=35"
	CBWRC45-__	45° Curved Worksurface Right Side Extension A=12 <sup>1</sup> / <sub>8</sub> " , B=35"
	CBWBC45-__	45° Curved Worksurface Both Side Extension A=12 <sup>13</sup> / <sub>16</sub> " , B=35 <sup>9</sup> / <sub>16</sub> "

### HOW TO ORDER STRAIGHT WORKSURFACES:

Example: 45° Straight Corner Worksurface Both Side Extension;  
Charcoal Essence Laminate; Medium Cherry Stain

CBWBS45 286 C7  
 Model Number      Laminate      Edge Stain Color

# CIRCULATION DESK COMPONENTS - CORNER WORKSURFACES

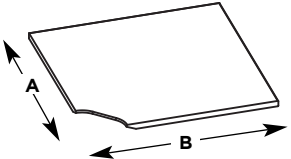
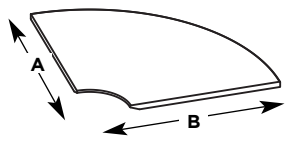
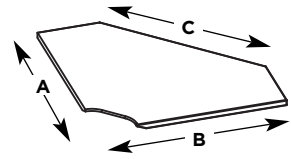
PRODUCT	MODEL #	DESCRIPTION
<b>90° SQUARE CORNER WORKSURFACE</b> 	CBWES90-__	90° Square Worksurface No Side Extension A=37 <sup>9</sup> / <sub>16</sub> " , B=37 <sup>9</sup> / <sub>16</sub> "
	CBWLS90-__	90° Square Worksurface Left Side Extension A=38 <sup>3</sup> / <sub>16</sub> " , B=37 <sup>9</sup> / <sub>16</sub> "
	CBWRS90-__	90° Square Worksurface Right Side Extension A=37 <sup>9</sup> / <sub>16</sub> " , B=38 <sup>3</sup> / <sub>16</sub> "
	CBWBS90-__	90° Square Worksurface Both Side Extension A=38 <sup>3</sup> / <sub>16</sub> " , B=38 <sup>3</sup> / <sub>16</sub> "
<b>90° CURVED CORNER WORKSURFACE</b> 	CBWEC90-__	90° Curved Worksurface No Side Extension A=38" , B=38"
	CBWLC90-__	90° Curved Worksurface Left Side Extension A=38" , B=38 <sup>5</sup> / <sub>8</sub> "
	CBWRC90-__	90° Curved Worksurface Right Side Extension A=38 <sup>5</sup> / <sub>8</sub> " , B=38"
	CBWBC90-__	90° Curved Worksurface Both Side Extension A=38 <sup>5</sup> / <sub>8</sub> " , B=38 <sup>5</sup> / <sub>8</sub> "
<b>90° HEXAGONAL CORNER WORKSURFACE</b> 	CBWEH90-__	90° Hexagonal Worksurface No Side Extension A=37 <sup>1</sup> / <sub>2</sub> " , B=37 <sup>1</sup> / <sub>2</sub> " , C=35 <sup>7</sup> / <sub>16</sub> "
	CBWLH90-__	90° Hexagonal Worksurface Left Side Extension A=37 <sup>1</sup> / <sub>2</sub> " , B=38 <sup>1</sup> / <sub>4</sub> " , C=35 <sup>7</sup> / <sub>16</sub> "
	CBWRH90-__	90° Hexagonal Worksurface Right Side Extension A=38 <sup>1</sup> / <sub>4</sub> " , B=37 <sup>1</sup> / <sub>2</sub> " , C=35 <sup>7</sup> / <sub>16</sub> "
	CBWBH90-__	90° Hexagonal Worksurface Both Side Extension A=38 <sup>1</sup> / <sub>4</sub> " , B=38 <sup>1</sup> / <sub>4</sub> " , C=35 <sup>7</sup> / <sub>16</sub> "

The most crucial aspect of ordering worksurfaces is to make sure they match the shape and width of the corresponding front panel. In addition, you need to know how the work surface fits into the rest of the desk. See the diagram on page 35 to understand which work surface you need to order based on where the work surface fits into the unit.

At this time you need to decide what type of laminate you want. This choice must be reflected in your model number for the work surface (see example below).

HOW TO ORDER STRAIGHT WORKSURFACES:  
 Example: 90° Hexagonal Corner Worksurface Both Side Extension;  
 Charcoal Essence Laminate; Medium Cherry Stain

CBWBH90 286 C7  
 Model Number      Laminate      Edge Stain Color

# CIRCULATION DESK COMPONENTS - INTERNAL COMPONENTS

PRODUCT                      MODEL #                      DESCRIPTION

## NARROW SHELVING SHELL

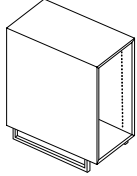

CBSNP-\_\_ Shelf Shell, Narrow - 33"H \*

CBSNS-\_\_ Shelf Shell, Narrow - 38"H \*

\* For Use with Worksurfaces with Body Pocket

## WIDE SHELVING SHELL

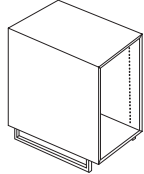

CBSWP-\_\_ Shelf Shell, Wide - 33"H

CBSWS-\_\_ Shelf Shell, Wide - 38"H

## ADJUSTABLE SHELVES

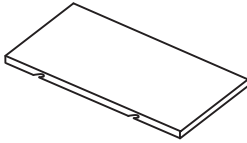

CBSMN-\_\_ Metal Adjustable Shelf, Narrow

CBSMW-\_\_ Metal Adjustable Shelf, Wide

CBSWN-\_\_ Wood Adjustable Shelf, Narrow

CBSWW-\_\_ Wood Adjustable Shelf, Wide

## FILE DRAWERS

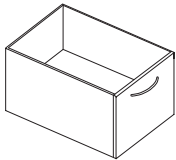

CBSFN-\_\_ File Drawer, Narrow

CBSFW-\_\_ File Drawer, Wide

## DRAWER

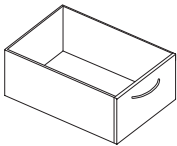

CBSDN-\_\_ Drawer, Narrow

CBSDW-\_\_ Drawer, Wide

## PULL-OUT SHELVES

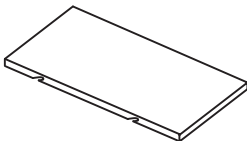

CBSON-\_\_ Pull-Out Shelf, Narrow

CBSOW-\_\_ Pull-Out Shelf, Wide

When ordering internal components, you first need to order a Shelving Shell. You may select from two widths, Narrow and Wide, and two heights, 33" and 38". It is recommended you order a Narrow Shelving Shell if you have a 54"W worksurface with a Body Pocket. A Wide Shelving Shell will interfere with the opening created by the Body Pocket.

After selecting your shell size, you may select the type of components you want to go in it. Keep in mind that you should only use File Drawers near the bottom of the unit. This will prevent the shelving unit from tipping over. You may use a File Drawer as the top drawer as long as you place another file drawer below it. Placing a File Drawer on top and shelves below will make the unit top heavy causing it to tip over.

The File Drawer and Drawer can be ordered with or without a lock. Specify which you would like in the model number (see example below).

### HOW TO ORDER INTERNAL COMPONENTS:

Example: File Drawer Narrow with Lock; Raven Paint; Medium Cherry Veneer

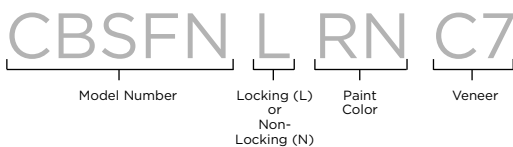



### HOW TO ORDER ACCESSORIES:

Example: Metal Adjustable Shelf Wide; Raven Paint

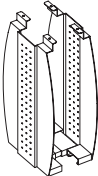
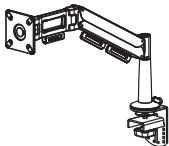

# CIRCULATION DESK COMPONENTS - ACCESSORIES

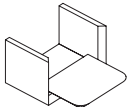
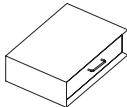
PRODUCT	MODEL #	DESCRIPTION
<b>CPU HOLDER</b>		
	CBPTWR-__	CPU Holder - for attachment under work surface
	CBCPU-__	CPU Holder - for attachment to modesty panel
<b>FLAT PANEL MONITOR ARM</b>		
	FPSM-D-ADJ2-AL	Adjustable Dual Arm Desk Mount Holds monitors weighing up to 15lbs.
	FPSM-D-ADJ2XX-AL	Adjustable Dual Arm Desk Mount Holds monitors weighing 15lbs. to 30lbs.
<b>DISPOSAL CABINET DOOR</b>		
	CBSCCWS-__	Disposal Cabinet Door for Wide and Tall Shell
	CBSCCNS-__	Disposal Cabinet Door for Narrow and Tall Shell
	CBSCCWP-__	Disposal Cabinet Door for Wide and Short Shell
	CBSCCNP-__	Disposal Cabinet Door Narrow and Short Shell
<b>CABINET DOOR</b>		
	CBSCOWS-__	Cabinet Door for Wide and Tall Shell
	CBSCONS-__	Cabinet Door for Narrow and Tall Shell
	CBSCOWP-__	Cabinet Door for Wide and Short Shell
	CBSCONP-__	Cabinet Door for Narrow and Short Shell
<b>PULL-OUT SHELF</b>		
	CBSOSN-__	Worksurface Mounted Pull-Out Shelf w/Open Slot
<b>PENCIL DRAWER</b>		
	CBSPN-__	Worksurface Mounted Pencil Drawer

Additional accessories are available for creating additional privacy, worksurface space and additional storage.

The Flat Monitor Arm can be installed at any time. A hole will need to be drilled to install it.

One item to note, the Disposal Cabinet Door and Cabinet Door can only be used with a Shelving Shell. The Doors can be ordered with or without a lock. Specify which you would like in the model number (see example below).

HOW TO ORDER ACCESSORIES:  
Example: Worksurface Screen; Raven Paint

CBWMP RN  
 Model Number      Paint Color

HOW TO ORDER INTERNAL COMPONENTS:  
Example: Cabinet Door for Wide and Tall Shell - Locking; Raven Paint; Medium Cherry Veneer

CBSCOWS L RN C7  
 Model Number      Locking (L) or Non-Locking (N)      Paint Color      Veneer