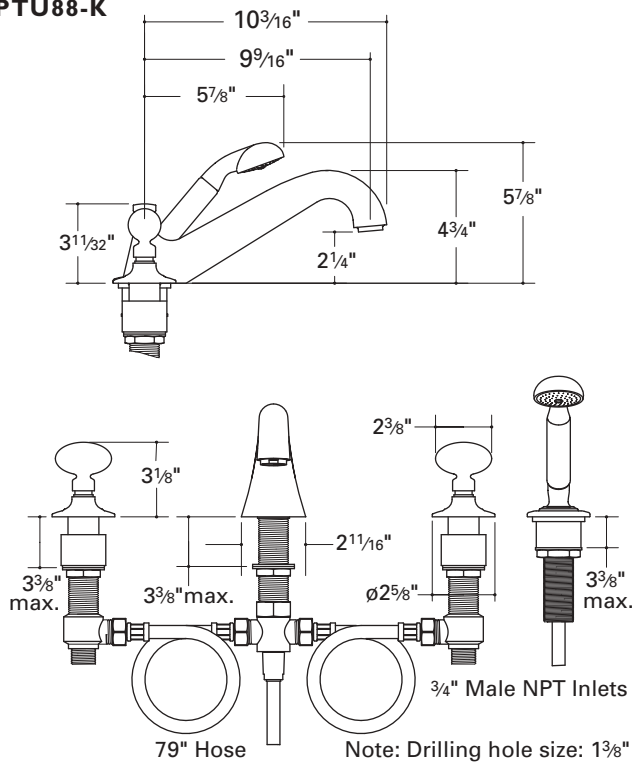
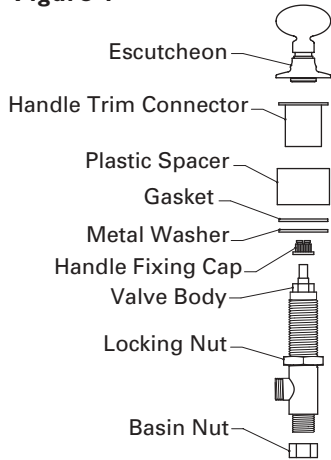
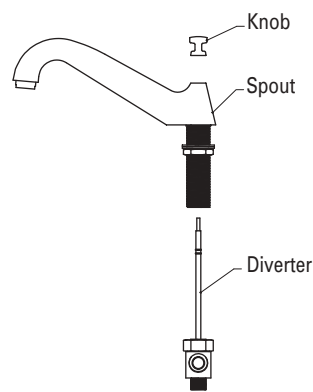
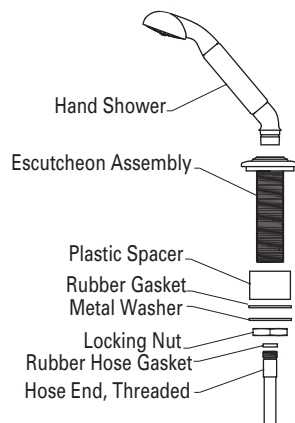

**OPTU88-K****NOTES**

- Use only a protected, smooth-jawed, or strap wrench on any finished surface.
- For proper installation, the deck surface should be installed prior to mounting the mixer.
- It is recommended that an access panel be provided for future servicing.
- Check the specifications (left) for drilling hole sizes.
- Run 3/4" supply lines for maximum water flow.
- Accessible shut-off valves, which will facilitate servicing, are recommended for the hot and cold feed lines.
- DO NOT use putty on deck fittings. Upper gaskets are provided.

**INSTALLATION**

- To remove the handle trim from the handle trim connector, unscrew the escutcheon and pull off the handle and escutcheon together. Then unscrew and lift off the handle trim connector. Leave locking nut, gaskets, and plastic spacer in place on the valve body (see fig. 1).
- Insert the valve body through the mounting hole using the plastic spacer (used for deck surfaces less than 1 1/2" thick). Then screw the handle trim connector onto the valve body until fully seated. Next, tighten the bottom locking nut to secure the valve to the deck. Repeat for the other valve assembly.
- Re-attach the handle trims to the handle trim connector

**Figure 1****Figure 2****Figure 3**

- Remove the locking nut, gasket and tee assembly from the spout shank and insert spout through the mounting hole. Please note that the diverter lift knob must be unthreaded before removing the tee assembly (see fig. 2).
- Re-attach the locking nut and gasket to spout shank and tighten until spout is fully secured. Then re-attach the tee assembly and diverter lift knob.
- Install the flexible supply hoses between the valve bodies and the tee assembly.
- Remove the locking nut, gaskets, and plastic spacer from the handshower escutcheon assembly and insert through the mounting hole. Then re-attach and tighten the locking nut, gaskets, and plastic spacer if needed (used for deck surfaces less than 1 1/2" thick) until fully secure (see fig.3).
- Feed the male threaded end of the hose up through the escutcheon assembly and attach the handshower using the gasket provided (see fig.3).
- Connect the female tapered end of the hose to the bottom of the tee assembly at the base of the spout.
- Connect the hot and cold water supplies to the side valve bodies.
- After installation, unscrew and remove the aerator assembly from the spout. Carefully open the hot and cold valves fully to flush out any debris in the supply lines. Once the lines have been flushed, close the valves and reinstall the aerator assembly. DO NOT divert the flow of water to the handshower until this step is completed.
- IMPORTANT: It is necessary to check for leaks and proper function of mixer prior to being enclosed.
- If further assistance is required, please contact Product Support at: 1-800-927-2120 (8AM-7PM EST).

These guidelines have been prepared for the professional contractor to aid in the installation of:  
**OPUS CONCEALED TUB FILLER WITH EGG CRYSTAL HANDLES (OPTU88-K)**

11/02

All dimensions are based on original specifications and are subject to change and variation. Please consult your Design Associate for current specifications.

W A T E R W O R K S<sup>®</sup>

## CARE AND CLEANING

**The lustrous finish on your fitting or fixture should be treated with care. Improper handling or cleaning can damage the surface of any finish and void the warranty.**

To clean the finish, wipe gently with a soft, damp cloth and then with a soft, dry towel. A mild soap solution can be used for daily cleaning. THE USE OF UNAUTHORIZED POLISHES, ABRASIVE CLEANERS, SOLVENTS, AMMONIA-BASED PRODUCTS, OR ACID BASE CLEANERS MAY DAMAGE THE FINISH AND WILL VOID THE WARRANTY.

Water contains lime and other minerals that are deposited after the water has evaporated. You can prevent deposits from forming by always wiping the fitting dry after use.

**In addition to the aforementioned care instructions, the following points are specific to certain finishes or products only. Always read and follow the instructions when using any cleaning or polishing products.**

### NON-METAL TUBS

In addition to mild soap and water, a non-abrasive basin tub and tile cleaner is recommended for regular cleaning and disinfecting. The use of any other cleaners or disinfectants may alter the surface finish and void the warranty.

### WHIRLPOOL AND AIRTUB SYSTEMS

Jet Fresh whirlpool cleaning solution is recommended for maintaining waterways.

### ANTIQUED COPPER AND BRASS

Select Waterworks fittings and basins are offered in finishes that have been artificially weathered, creating a patina that will develop and change with time. In addition to mild soap and water, a natural citrus-based product may be used for regular cleaning. The use of any other cleaners or disinfectants may alter the surface finish and void the warranty. Please note that prolonged contact with certain items such as toothpaste, acidic fruits and vegetables, and wines will alter the surface finish. Also, the use of polishing agents will remove the patina and restore the metal to its original shine. Once removed, the patina will naturally redevelop with time.

### ARCHITECTURAL BRONZE

In addition to mild soap and water, a natural citrus-based product may be used for regular cleaning. The use of any other cleaners or disinfectants may alter the surface finish and void the warranty. Please note that prolonged contact with certain items such as toothpaste, acidic fruits and vegetables, and wines will alter the surface finish. Also, the use of polishing agents will remove the finish.

### CHINA, CERAMIC AND PORCELAIN

Do not use abrasive cleaners, as this will dull the surface finish. A non-abrasive basin tub and tile cleaner is recommended for regular cleaning and disinfecting. The use of any other cleaners or disinfectants may alter the surface finish and void the warranty.

### CHROME

In addition to mild soap and water, a non-abrasive basin tub and tile cleaner is recommended for regular cleaning and disinfecting. The use of any other cleaners or disinfectants may alter the surface finish and void the warranty. Cape Cod Polishing Cloths may be used for the occasional polishing. If you desire additional protection, the use of Faucet Brite will aid in protecting the surface finish from mineral deposits present in your water supply. This should be reapplied as necessary to continue protection.

### MATTE NICKEL, LUMIN AND GOLD

In addition to mild soap and water, a non-abrasive basin tub and tile cleaner is recommended for regular cleaning and disinfecting. The use of any other cleaners or disinfectants may alter the surface finish and void the warranty. Also, the use of polishing agents will remove the finish. If you desire additional protection, the use of Faucet Brite will aid in protecting the surface finish from mineral deposits present in your water supply. This should be reapplied as necessary to continue protection.

### NICKEL

In addition to mild soap and water, a non-abrasive basin tub and tile cleaner is recommended for regular cleaning and disinfecting. The use of any other cleaners or disinfectants may alter the surface finish and void the warranty. Cape Cod Polishing Cloths may be used for the occasional polishing. The use of any other polishing agents will remove the finish and void the warranty. If you desire additional protection, the use of Faucet Brite will aid in protecting the surface finish from mineral deposits present in your water supply. This should be reapplied as necessary to continue protection.

### SILVER

Fittings offered in a silver finish will tarnish with age. This finish may be restored to its original luster by using Faucet Brite or a non-abrasive silver polish. This should be reapplied as necessary to continue protection. Faucet Brite will also help to prolong the time between regular polishing.

### UNLACQUERED BRASS AND COPPER

Items purchased in the unlacquered brass and copper finishes will change with time as they develop a natural patina. The original shine can be restored using Faucet Brite or an appropriate polishing compound. If you desire additional protection, the use of Faucet Brite will aid in protecting the surface finish from mineral deposits present in your water supply and prolong the time between regular polishing. This should be reapplied as necessary to continue protection.

## WARRANTY

### LIMITED LIFETIME MECHANICAL WARRANTY:

Waterworks warrants to the initial purchaser all plumbing and accessory products sold by Waterworks, which are installed in a residence to be used in a residential application, to be free from manufacturing defects in materials and workmanship for as long as the purchaser continues to own and maintain the residence where the products are initially installed.

### FIVE-YEAR FINISH WARRANTY:

Waterworks warrants to the purchaser the finish of all plumbing and accessory products sold by Waterworks, which are installed in a residence to be used in a residential application, to be free from manufacturing defects in materials and workmanship for a period of five years from installation of the products. Waterworks must receive notice of any warranty claim within the five-year warranty period.

### REPAIR OR REPLACEMENT:

If within the applicable warranty period the covered products shall be proved to the satisfaction of Waterworks to be defective, Waterworks will repair or replace such products, at its expense (provided that such repair or replacement shall not include installation costs). Waterworks' obligation shall be limited to such repair and replacement and shall be conditioned upon Waterworks' receiving notice of any alleged defect within the applicable warranty period. [Purchaser shall be responsible for all shipping charges for returned products.]

### LIMITATIONS ON WARRANTY COVERAGE:

The warranties set forth above shall be extended only to the purchaser and do not apply to any purchaser where the products are used for commercial applications and usage. Furthermore, the warranties do not cover installation or any other labor charges and do not apply to:

- (i) products which have been repaired, altered or modified in any way by purchaser or any person other than Waterworks or not using original Waterworks spare parts, unless previously authorized in writing by Waterworks;
- (ii) products which have not been installed, used, maintained or stored in accordance with the instructions provided to purchaser by Waterworks;
- (iii) products which have been used for purposes other than or in a manner contrary to their intended and normal use;
- (iv) products which have been damaged as a result of misuse, negligence, freezing, accident or faulty installation or maintenance; and
- (v) products damaged by the effects of dirt, salt water air, hard water, limescale, or abrasive or aggressive cleaners. If the normal life span of any product is shorter than the applicable warranty period, the warranty shall apply only during the period of such shorter life span.

### NOTICE OF WARRANTY CLAIMS:

For all warranty claims please call Waterworks Product Support at 800-927-2120, or write to Waterworks Product Support at 60 Backus Avenue, Danbury, Connecticut 06810.

**The warranties provided herein are conveyed only to the purchaser of products sold by Waterworks after January 1, 2000, and installed in a residential application.**

**Except as specifically set forth above, Waterworks does not make any other warranty, express or implied, including without limitation, any implied warranty of merchantability or fitness for a particular purpose. In no event shall Waterworks be liable to any person or entity for any indirect, special, incidental or consequential damages or loss (including damages for loss of business, loss of profits, or the like), whether based on breach of contract, tort (including negligence), product liability or otherwise, even if it has been advised of the possibility of such damages. Waterworks' liability on any claim of any kind, including negligence, shall in no case exceed the contract price paid by the purchaser for the product claimed to be defective or unsuitable.**