

GUSV12R (rough) & **BDSV47** (trim)

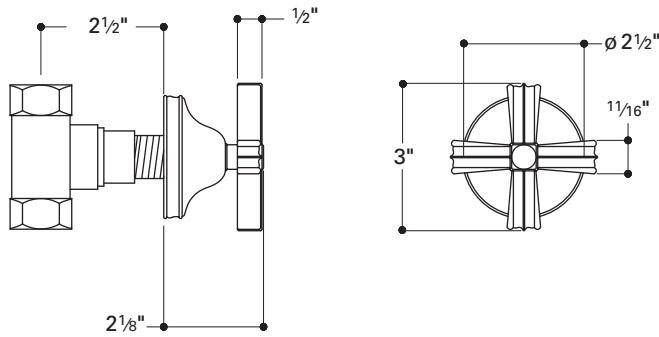

Note: 3/4" NPT

NOTES:

- Use only a protected, smooth-jawed, or strap wrench on any finished surface.

ROUGH-IN:

- Install the valve with the water flowing in the direction indicated.
- **IMPORTANT:** Valve rough-in is 2 1/2" from the centerline of the supplies to the face of the finished wall.
- Separate supply stop valves, which will facilitate servicing should be installed in an accessible location.

FINISH:

- Screw on trim and measure from the base of the escutcheon to the finished wall. Remove the trim and retain this measurement.
- Cut the valve stem and threaded sleeve so that the trim becomes flush with the finished wall.
- The amount cut from the valve stem and threaded sleeve should be the same as the distance measured in the previous step.
- Reattach the trim and check to ensure it is flush with the finished wall. If necessary, cut the valve stem and threaded sleeve further to make flush.
- Carefully turn on the water supply and check all connections for leaks.
- If further assistance is required, please contact Product Support at 1-800-927-2120 (8am-7pm EST).

Figure 1

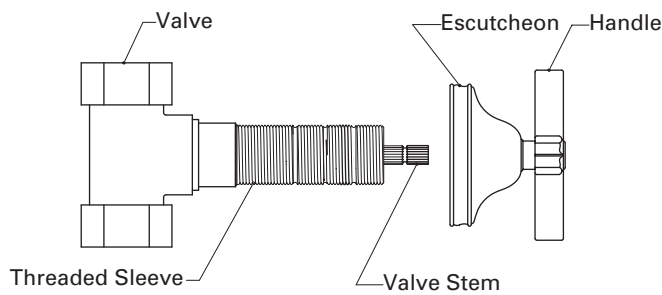

CARE AND CLEANING

The lustrous finish on your fitting should be treated with care. Improper handling or cleaning can damage the surface of any metal finish.

To clean the finish, wipe gently with a soft damp cloth and wipe dry with a soft towel. Use only a mild soap solution if required. THE USE OF POLISH, ABRASIVE CLEANERS, SOLVENTS, AMMONIA-BASED PRODUCTS, OR ACID CLEANERS WILL DAMAGE THE FINISH AND VOID THE WARRANTY.

Water contains lime and other minerals that will be left on the surface after the water has evaporated. You can prevent deposits from forming by always wiping the fitting dry immediately after use.

If you desire additional protection, the use of a pure carnauba automotive wax that does not contain cleaning agents will help to protect the surface finish from mineral deposits present in your water supply. This can be reapplied as necessary to continue protection.

Please note: In addition to the aforementioned care instructions, the following points are specific to certain finishes only. Select Waterworks faucets and basins are offered in finishes that have been pre-weathered, creating a patina that will continue to develop with age. In addition, items purchased in the unlacquered brass and copper finishes will change over time and may be polished using appropriate polishing compounds. Fittings offered in a silver-plated finish will tarnish with age. This finish may be restored to its original luster by using a non-abrasive silver polish. Be sure to read and follow the polish manufacturer's instructions for all applications.

WARRANTY

LIMITED LIFETIME MECHANICAL WARRANTY:

Waterworks warrants to the initial purchaser all plumbing and accessory products sold by Waterworks, which are installed in a residence to be used in a residential application, to be free from manufacturing defects in materials and workmanship for as long as the purchaser continues to own and maintain the residence where the products are initially installed.

FIVE-YEAR FINISH WARRANTY:

Waterworks warrants to the purchaser the finish of all plumbing and accessory products sold by Waterworks, which are installed in a residence to be used in a residential application, to be free from manufacturing defects in materials and workmanship for a period of five years from installation of the products. Waterworks must receive notice of any warranty claim within the five-year warranty period.

REPAIR OR REPLACEMENT:

If within the applicable warranty period the covered products shall be proved to the satisfaction of Waterworks to be defective, Waterworks will repair or replace such products, at its expense (provided that such repair or replacement shall not include installation costs). Waterworks' obligation shall be limited to such repair and replacement and shall be conditioned upon Waterworks' receiving notice of any alleged defect within the applicable warranty period. [Purchaser shall be responsible for all shipping charges for returned products.]

LIMITATIONS ON WARRANTY COVERAGE:

The warranties set forth above shall be extended only to the purchaser and do not apply to any purchaser where the products are used for commercial applications and usage. Furthermore, the warranties do not cover installation or any other labor charges and do not apply to:

- (i) products which have been repaired, altered or modified in any way by purchaser or any person other than Waterworks or not using original Waterworks spare parts, unless previously authorized in writing by Waterworks;
- (ii) products which have not been installed, used, maintained or stored in accordance with the instructions provided to purchaser by Waterworks;
- (iii) products which have been used for purposes other than or in a manner contrary to their intended and normal use;
- (iv) products which have been damaged as a result of misuse, negligence, freezing, accident or faulty installation or maintenance; and
- (v) products damaged by the effects of dirt, salt water air, hard water, limescale, or abrasive or aggressive cleaners. If the normal life span of any product is shorter than the applicable warranty period, the warranty shall apply only during the period of such shorter life span.

NOTICE OF WARRANTY CLAIMS:

For all warranty claims please call Waterworks Product Support at 800-927-2120, or write to Waterworks Product Support at 60 Backus Avenue, Danbury, Connecticut 06810.

The warranties provided herein are conveyed only to the purchaser of products sold by Waterworks after January 1, 2000, and installed in a residential application.

Except as specifically set forth above, Waterworks does not make any other warranty, express or implied, including without limitation, any implied warranty of merchantability or fitness for a particular purpose. In no event shall Waterworks be liable to any person or entity for any indirect, special, incidental or consequential damages or loss (including damages for loss of business, loss of profits, or the like), whether based on breach of contract, tort (including negligence), product liability or otherwise, even if it has been advised of the possibility of such damages. Waterworks' liability on any claim of any kind, including negligence, shall in no case exceed the contract price paid by the purchaser for the product claimed to be defective or unsuitable.