

- EALS11** (cross handle)
- EALS12-K** (metal lever handle)
- EALS13-K** (white porcelain handle)
- EALS14-K** (black porcelain handle)
- EALS15-K** (oak lever handle)

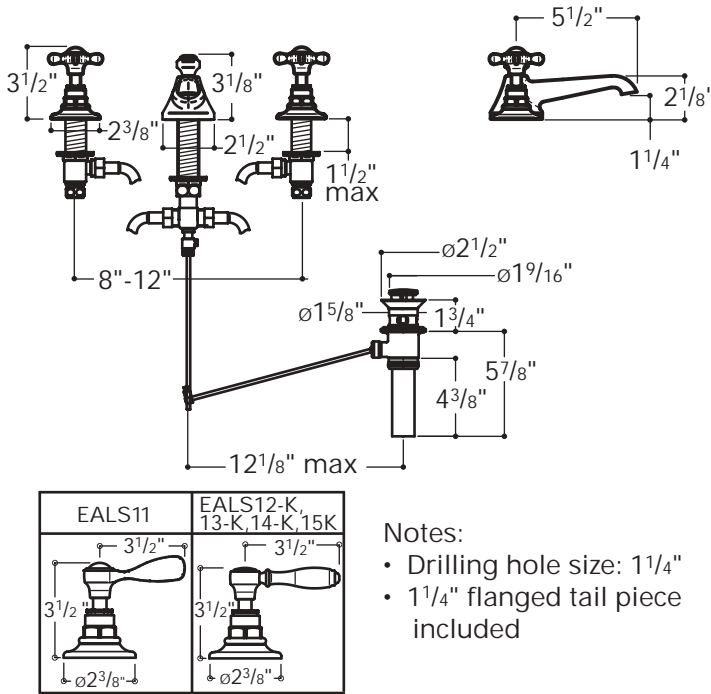

Notes:

- Drilling hole size: 1 1/4"
- 1 1/4" flanged tail piece included

SIDE VALVE INSTALLATION:

1. With the lock nut (13) and upper sealing gasket (12) installed on the side valve (15), insert the side valve into the hole in the mounting surface so at least 1/2" of threads are exposed.
2. Place the upper sealing gasket (11) onto the side valve and then thread the base escutcheon (10) onto the side valve.
3. Thread the handle assembly (1-9) onto the side valve until it stops. Hand tight is adequate; if this assembly is too tight, the handle will bind.
4. Unthread the base escutcheon until it contacts the cover (6) which will assure proper side valve height.
5. Tighten the lock nut up against the underside of the mounting surface to secure the side valve.
6. Repeat these steps to install the second side valve.

SPOUT AND DRAIN INSTALLATION:

7. Loosen the slotted set screw (41) from the end of the tee (37) and then pull off the lift rod tension assembly (41-44).
8. Loosen the packing nut (40) at the base of the tee, unthread the tee nut (33) and remove the tee assembly (32-40) and washer (31) from the spout shank (26).
9. Unthread and remove the spout mounting nut (30) and rubber spout washer (29) from the spout.
10. Insert the spout assembly through the spout hole of the mounting surface, reinstall the rubber spout washer and then tighten the spout mounting nut to secure the spout to the mounting surface.
11. Reattach the tee assembly and then make sure to tighten the packing nut (40) to prevent leaks.
12. Reinstall the lift rod tension assembly, do NOT fully tighten the nut (44) at the base of this assembly.
13. Connect each of the supply hoses (24) to the adjacent side valve, making sure the hoses are not pinched/kinked.
14. Remove the upper collar (48) from the pop-up drain assembly and discard the upper gasket (49).
15. Set the upper collar in the lavatory drain opening using a clear adhesive silicone.

INSTALLATION GUIDELINES:

IMPORTANT:

- To ensure this product is installed properly, you must read and follow these guidelines.
- The owner/user of the faucet must keep this information for future reference.
- Be sure your installation conforms to local codes.
- Refer to the specification and assembly drawings attached. Faucet is sold partially assembled but shown fully disassembled for illustrative and service purposes only.
- Inspect this product to assure you have all parts required for proper installation.
- Use only a strap wrench or protected/smooth-jaw wrench on any finished surface.
- If possible, install the faucet assembly on the sink or mounting surface before setting.
- Do NOT use putty during this installation.

- 16. Reattach the lower drain assembly (51) using the gasket (50) provided and then tighten until fully secured. A clear adhesive silicone may be used to ensure a watertight seal between the gasket and lavatory.
- 17. Remove the knurled nut (55) from the lower drain assembly and then insert the horizontal pivot rod (56) and reattach the knurled nut.
- 18. Insert the vertical lift rod (20-22) into the spout and then connect the vertical lift rod to the horizontal pivot rod (56) using the linkage (23) provided. Note that these rods may be field cut.
- 19. Attach the tail piece (54,53) using the gasket (52) provided.
- 20. Connect the side valves (12-19) to the water supply valves (not supplied).

INSPECT THE INSTALLATION:

- 21. Carefully open the hot and cold valves to flush out any debris in the supply lines. The flow restrictor (36) is located in the tee (37) and can be serviced by removing the tee. After removing the tee, unthread the nut (34) and washer (35) and then insert a small screwdriver into the outlet on top of the tee and pop the restrictor out of the hole.
 - 22. Inspect all connections for leaks.
 - 23. Close the drain and then fill the sink with water to make sure the drain stopper (45) operates and seals properly.
 - 23a. The nut (44) at the base of the tee can be adjusted to change the tension required to hold the vertical lift rod in position while the drain is closed.
 - 23b. To adjust the height of the drain stopper, turn the adjustment screw (47) at the base of the stopper and then tighten the locking nut to secure.
 - 23c. The linkage (23) position will effect drain stopper function, adjust as needed.
- If further assistance is required, please contact Product Support at 1-800-927-2120 (8am-7pm EST).

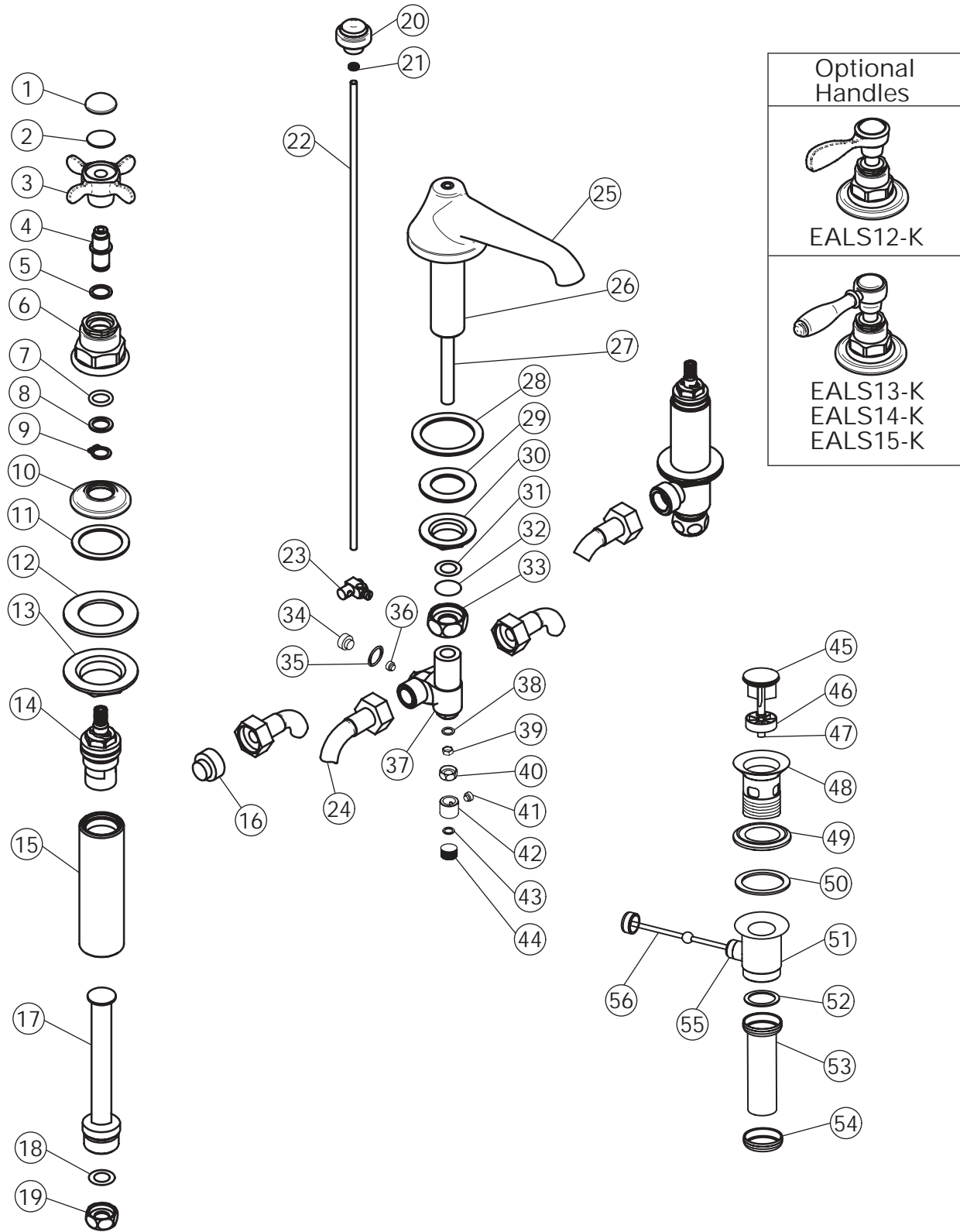

Optional
Handles

EALS12-K

EALS13-K
EALS14-K
EALS15-K

CARE AND CLEANING

The lustrous finish on your fitting or fixture should be treated with care. Improper handling or cleaning can damage the surface of any finish and void the warranty.

To clean the finish, wipe gently with a soft, damp cloth and then with a soft, dry towel. A mild soap solution can be used for daily cleaning. THE USE OF UNAUTHORIZED POLISHES, ABRASIVE CLEANERS, SOLVENTS, AMMONIA-BASED PRODUCTS, OR ACID BASE CLEANERS MAY DAMAGE THE FINISH AND WILL VOID THE WARRANTY.

Water contains lime and other minerals that are deposited after the water has evaporated. You can prevent deposits from forming by always wiping the fitting dry after use.

In addition to the aforementioned care instructions, the following points are specific to certain finishes or products only. Always read and follow the instructions when using any cleaning or polishing products.

NON-METAL TUBS

In addition to mild soap and water, a non-abrasive basin tub and tile cleaner is recommended for regular cleaning and disinfecting. The use of any other cleaners or disinfectants may alter the surface finish and void the warranty.

WHIRLPOOL AND AIRTUB SYSTEMS

Jet Fresh whirlpool cleaning solution is recommended for maintaining waterways.

ANTIQUED COPPER AND BRASS

Select Waterworks fittings and basins are offered in finishes that have been artificially weathered, creating a patina that will develop and change with time. In addition to mild soap and water, a natural citrus-based product may be used for regular cleaning. The use of any other cleaners or disinfectants may alter the surface finish and void the warranty. Please note that prolonged contact with certain items such as toothpaste, acidic fruits and vegetables, and wines will alter the surface finish. Also, the use of polishing agents will remove the patina and restore the metal to its original shine. Once removed, the patina will naturally redevelop with time.

ARCHITECTURAL BRONZE

In addition to mild soap and water, a natural citrus-based product may be used for regular cleaning. The use of any other cleaners or disinfectants may alter the surface finish and void the warranty. Please note that prolonged contact with certain items such as toothpaste, acidic fruits and vegetables, and wines will alter the surface finish. Also, the use of polishing agents will remove the finish.

CHINA, CERAMIC AND PORCELAIN

Do not use abrasive cleaners, as this will dull the surface finish. A non-abrasive basin tub and tile cleaner is recommended for regular cleaning and disinfecting. The use of any other cleaners or disinfectants may alter the surface finish and void the warranty.

CHROME

In addition to mild soap and water, a non-abrasive basin tub and tile cleaner is recommended for regular cleaning and disinfecting. The use of any other cleaners or disinfectants may alter the surface finish and void the warranty. Cape Cod Polishing Cloths may be used for the occasional polishing. If you desire additional protection, the use of Faucet Brite will aid in protecting the surface finish from mineral deposits present in your water supply. This should be reapplied as necessary to continue protection.

MATTE NICKEL, LUMIN AND GOLD

In addition to mild soap and water, a non-abrasive basin tub and tile cleaner is recommended for regular cleaning and disinfecting. The use of any other cleaners or disinfectants may alter the surface finish and void the warranty. Also, the use of polishing agents will remove the finish. If you desire additional protection, the use of Faucet Brite will aid in protecting the surface finish from mineral deposits present in your water supply. This should be reapplied as necessary to continue protection.

NICKEL

In addition to mild soap and water, a non-abrasive basin tub and tile cleaner is recommended for regular cleaning and disinfecting. The use of any other cleaners or disinfectants may alter the surface finish and void the warranty. Cape Cod Polishing Cloths may be used for the occasional polishing. The use of any other polishing agents will remove the finish and void the warranty. If you desire additional protection, the use of Faucet Brite will aid in protecting the surface finish from mineral deposits present in your water supply. This should be reapplied as necessary to continue protection.

SILVER

Fittings offered in a silver finish will tarnish with age. This finish may be restored to its original luster by using Faucet Brite or a non-abrasive silver polish. This should be reapplied as necessary to continue protection. Faucet Brite will also help to prolong the time between regular polishing.

UNLACQUERED BRASS AND COPPER

Items purchased in the unlacquered brass and copper finishes will change with time as they develop a natural patina. The original shine can be restored using Faucet Brite or an appropriate polishing compound. If you desire additional protection, the use of Faucet Brite will aid in protecting the surface finish from mineral deposits present in your water supply and prolong the time between regular polishing. This should be reapplied as necessary to continue protection.

WARRANTY**LIMITED LIFETIME MECHANICAL WARRANTY:**

Waterworks warrants to the initial purchaser all plumbing and accessory products sold by Waterworks, which are installed in a residence to be used in a residential application, to be free from manufacturing defects in materials and workmanship for as long as the purchaser continues to own and maintain the residence where the products are initially installed.

FIVE-YEAR FINISH WARRANTY:

Waterworks warrants to the purchaser the finish of all plumbing and accessory products sold by Waterworks, which are installed in a residence to be used in a residential application, to be free from manufacturing defects in materials and workmanship for a period of five years from installation of the products. Waterworks must receive notice of any warranty claim within the five-year warranty period.

REPAIR OR REPLACEMENT:

If within the applicable warranty period the covered products shall be proved to the satisfaction of Waterworks to be defective, Waterworks will repair or replace such products, at its expense (provided that such repair or replacement shall not include installation costs). Waterworks' obligation shall be limited to such repair and replacement and shall be conditioned upon Waterworks' receiving notice of any alleged defect within the applicable warranty period. Purchaser shall be responsible for all shipping charges for returned products.

LIMITATIONS ON WARRANTY COVERAGE:

The warranties set forth above shall be extended only to the purchaser and do not apply to any purchaser where the products are used for commercial applications and usage. Furthermore, the warranties do not cover installation or any other labor charges and do not apply to:

- (i) products which have been repaired, altered or modified in any way by purchaser or any person other than Waterworks or not using original Waterworks spare parts, unless previously authorized in writing by Waterworks;
- (ii) products which have not been installed, used, maintained or stored in accordance with the instructions provided to purchaser by Waterworks;
- (iii) products which have been used for purposes other than or in a manner contrary to their intended and normal use;
- (iv) products which have been damaged as a result of misuse, negligence, freezing, accident or faulty installation or maintenance; and
- (v) products damaged by the effects of dirt, salt water air, hard water, limescale, or abrasive or aggressive cleaners. If the normal life span of any product is shorter than the applicable warranty period, the warranty shall apply only during the period of such shorter life span.

NOTICE OF WARRANTY CLAIMS:

For all warranty claims please call Waterworks Product Support at 800-927-2120, or write to Waterworks Product Support at 60 Backus Avenue, Danbury, Connecticut 06810.

The warranties provided herein are conveyed only to the purchaser of products sold by Waterworks after January 1, 2000, and installed in a residential application.

Except as specifically set forth above, Waterworks does not make any other warranty, express or implied, including without limitation, any implied warranty of merchantability or fitness for a particular purpose. In no event shall Waterworks be liable to any person or entity for any indirect, special, incidental or consequential damages or loss (including damages for loss of business, loss of profits, or the like), whether based on breach of contract, tort (including negligence), product liability or otherwise, even if it has been advised of the possibility of such damages. Waterworks' liability on any claim of any kind, including negligence, shall in no case exceed the contract price paid by the purchaser for the product claimed to be defective or unsuitable.