

Residential Elevators * Wheelchair-Compatible Elevators
 RESIDENTIAL AND COMMERCIAL DUMBWAITERS
 CUSTOMER:

CONTRACTOR:

TITLE: **PACA RYDE
 NOTES & SPECIFICATIONS
 750/1000 LB. CAPACITY**

QUOTE NUMBER:

DRAWN BY:	SCALE:	DWG. NO.
APPD:	DATE:	C-002617

REVISIONS			
LETTER:	DESCRIPTION:	DATE:	BY:

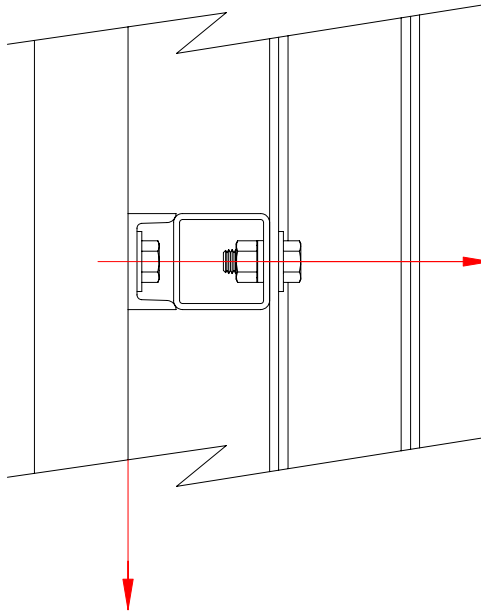

**300 LBS. MAX TENSION
 PER FASTENER**

**300 LBS. MAX SHEAR
 PER FASTENER**

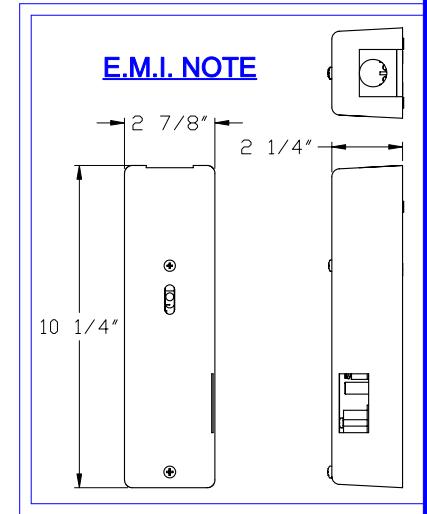

GENERAL NOTES

THE FOLLOWING IS TO BE PROVIDED BY THE PURCHASER AND/OR CONTRACTOR UNLESS OTHERWISE SPECIFIED.

- ELEVATOR TO BE CONSTRUCTED IN ACCORDANCE WITH ASME A17.1 PART 5.3 AND ALL LOCAL CODES.
- ELECTRICAL REQUIREMENTS ARE BY OTHERS AS FOLLOWS:
 3 POLE DISCONNECT SWITCH
 230 VAC 30 AMP CIRCUIT 1 PHASE FUSED WITH 30 AMP SLOW BLOW FUSE TO BE INSTALLED IN A LOCKABLE FUSED DISCONNECT.
 120 VAC 15 AMP CIRCUIT 1 PHASE WITH 15 AMP PROTECTION
- A MINIMUM OF ONE HOISTWAY DOOR, ENTRANCE, AND ASSOCIATED FRAMING SHALL BE LEFT UNFINISHED UNTIL THE ELEVATOR IS SET IN PLACE.
- HOISTWAY MUST BE PLUM WITHIN 1/8 INCH PER 10 FT OF HEIGHT AND SQUARE AT ANY POINT WITHIN 1/4 INCH BASED ON DIFFERENCE IN DIAGONAL MEASUREMENTS.
- MACHINE ROOM MUST BE PROVIDED FOR THE OPERATING EQUIPMENT THAT MEETS N.E.C. CLEAR SPACE REQUIREMENTS AND ALL LOCAL CODES. MACHINE ROOM MUST HAVE A LIGHT AND A CONVENIENCE OUTLET.
- ALL HOISTWAY DOORS REQUIRE AN INTERLOCK, DOOR HANDLE, AND LATCH SET.
- STRUCTURE MUST BE CAPABLE OF SUPPORTING THE APPROPRIATE LOADS. LOCAL ENGINEERING SUPPORT IS RECOMMENDED.
- ANY ALTERATIONS TO THE EQUIPMENT WITHOUT WRITTEN AUTHORIZATION BY WAUPACA ELEVATOR WILL VOID ALL WARRANTIES.
- WHEN USED, CONCRETE MUST BE A MINIMUM OF 4" THICK 3500 PSI.
- LOAD ON PIT FLOOR IS 4000 LBS.

GENERAL SPECIFICATIONS

RATED LOAD (CAPACITY):		SPEED:	40 FPM
WEIGHT OF CAB,GATE(S),AND FIXTURES SHALL NOT EXCEED 500LBS.			
SUSPENSION ROPE:	(2) 3/8-8x19 TRACTION STEEL FC		
GUIDE RAIL:	J-TYPE CONFIGURATION		
CYLINDER (1 PIECE):	4.5" O.D.		
PLUNGER (1 PIECE):	2.75" O.D.		
OIL LINE PIPE:	3/4" SCHEDULE 80		
WORKING PRESSURE:	525 PSI, 5.5 GPM		
MOTOR:	2.5 HP STARTING AMPS: 36 FLA: 18.7 LRA: 40		
CAB LIGHT CIRCUIT:	120V, 15A		
CAB ALARM BELL:	ALARM W/BATTERY		
CAB MODEL:			
CAB SIZE:			
TRAVEL:	NUMBER OF STOPS:		
HOISTWAY DOOR INTERLOCKS:			
CONTROLLER SIZE:	24" x 18" x 8"	BATTERY BOX SIZE:	12" x 12" x 8"