

Installation Instructions

Wall Base



1-877-MY-KWALU (695-9258) • kwalu.com

Note: Installation of Kwalu wall base generally requires at least two people working together.

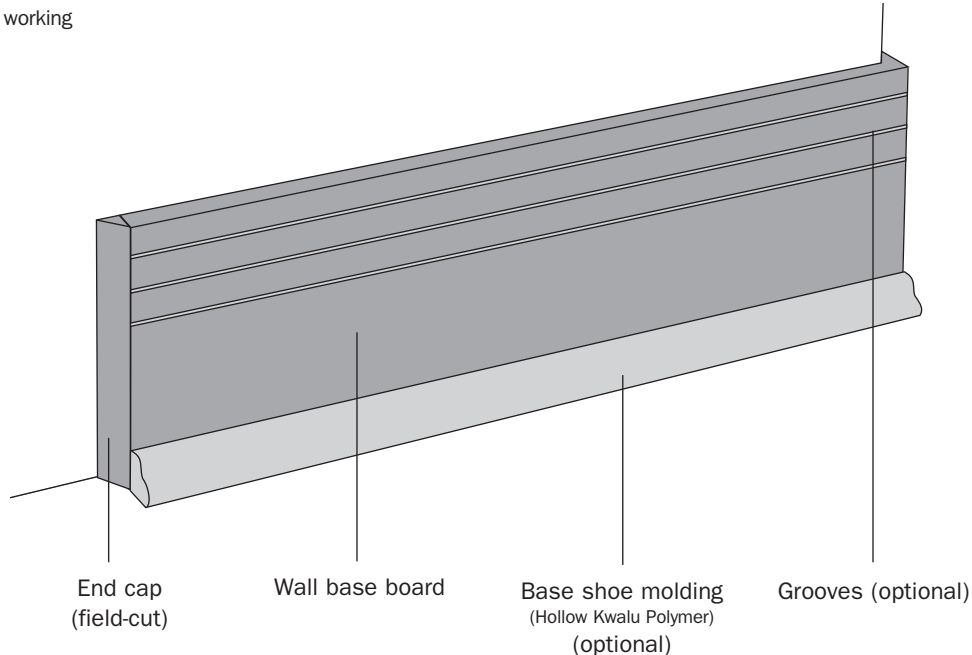

Materials (supplied with order):

- Wall Base Boards – 12' long
- External Corners*
- Base Shoe End Caps
- Color-matched Caulk
- Solid Polymer Base Shoe – 12' long*
(Hollow Kwalu Polymer)

*These components are optional and may not be included in your wall base system. Refer to Kwalu quotation for bill of materials included in your system

Required Tools (supplied by Installer):

- Safety Glasses
- Protective Gloves
- Pencil/Felt Tip Marker
- Stud Finder
- Tape Measure
- Laser Level and/or Chalk Line
- '0000' Fine Steel Wool
- Water Bucket & Clean Cloth/Sponge
- Minimum 10" Power Miter Saw w/ 80-Tooth Carbide Blade
- 6' Level or larger
- Pneumatic Brad Nailer
- 2" and 1" Long 18 Gauge Wire Brads
- Caulk Gun
- Loctite Power Grab Heavy Duty or Loctite Power Grab All-Purpose Construction Adhesive

Delivery, Storage and Handling:

1. All materials will be delivered to the jobsite in original unopened factory packaging. Upon delivery, carefully inspect all packages to ensure that all required materials have been delivered in acceptable condition.
2. Store all materials flat in a dry, environmentally controlled area between 65°F and 80°F, and

protected from the elements as well as direct sunlight.

3. Do not install wall base until all facility finish work has been completed, including painting.
4. All materials must be acclimated to installation conditions at least 24 hours before installation is to begin.

Preparation:

1. Ensure that all wall surfaces and wall protection system components are free from moisture, dust, dirt, and wet or chipping paint, etc.
2. Ensure that all walls are straight, plumb and free of imperfections.
3. Before starting, check the floor for level. If the floor is not level, locate the highest and lowest points in each room to receive wall base, then determine the difference in height between the high point and the low point. If base shoe is not being used, the differential should not be more than $\frac{1}{8}$ ". If base shoe is being used (base shoe is always highly recommended to help mask variations in floor elevations), this floor elevation differential should not be more than $\frac{1}{2}$ ". If the change in floor elevation exceeds these parameters, wall base should be scribed to the floor to reduce the margin at the lowest elevation to an acceptable level while ensuring it is installed on a level plane.

Special Instructions:

1. For proper cutting, use only SHARP carbide tipped blades in circular saws and miter saws.
2. Installation of Kwalu wall base requires two people working together.
3. When using nail gun, hold in contact with surface to be fastened. DO NOT BOUNCE on the surface. Adjust the nail gun so that the nail head just penetrates the polymer layer.
4. Do NOT use nails closer than $\frac{1}{4}$ " from the edge of the wall protection component.
5. Base shoe molding may crack when pneumatic nailer is used to fasten them to the wall, particularly when not completely acclimated to room temperature. Use adhesive to fasten shoe molding in place wherever possible, and utilize 1" wire brads where necessary.
6. Kwalu strongly recommends the use of Loctite Power Grab Heavy Duty or Loctite Power Grab All-Purpose Construction Adhesive. Other adhesives may cause a damaging reaction with the Kwalu product. Use of other adhesives will void the product warranty.
7. When applying construction adhesive to wall base, apply a $\frac{1}{8}$ " bead in a loop or multiple overlapping circular patterns.

Installation:**1. Lay out the Wall Base Installation on Walls**

- a. Locate the walls to receive wall base, and locate on each wall the height to which the top of the wall base is to be installed. Installation height will vary with applications and preferences. Snap a chalk line, draw a level line or use a laser level to mark this height across the entire wall.
- b. Find the location of framing studs along the entire length of the wall, and lightly mark those locations just above the level line. For drywall or plaster walls, it is strongly recommended that, wherever possible, wall base is fastened to metal or wood studs, or blocking between studs, for maximum strength.

2. Install the Wall Base

- a. Measure the section of wall to be covered by the wall base (i.e., from door frame to door frame).
- b. Determine the desired set-back, if any, between door frames, etc. at wall base ends (this distance

- will vary with preference).
- Subtract the necessary set-backs, if any, from the overall measurement of the wall section. Now subtract $\frac{3}{4}$ " for each end cap or inside corner, and/or add $\frac{3}{4}$ " for each outside corner. The result is the length of the front face of the wall base for that section of wall.
 - Transfer this measurement to the front face of a length of Kwalu wall base, and lightly mark the board.
 - At each end cap, the wall base must be mitered at 22.5° on a back cut. The cut should start at the measurement mark just made on the face and cut the back side of the wall base shorter along a 22.5° angle (see **figure 1**). Outside corners must be mitered at 45° , also on a back cut. Inside corners must be mitered at 45° from the measurement mark on the front face of the wall base and leaving the back of the board longer.

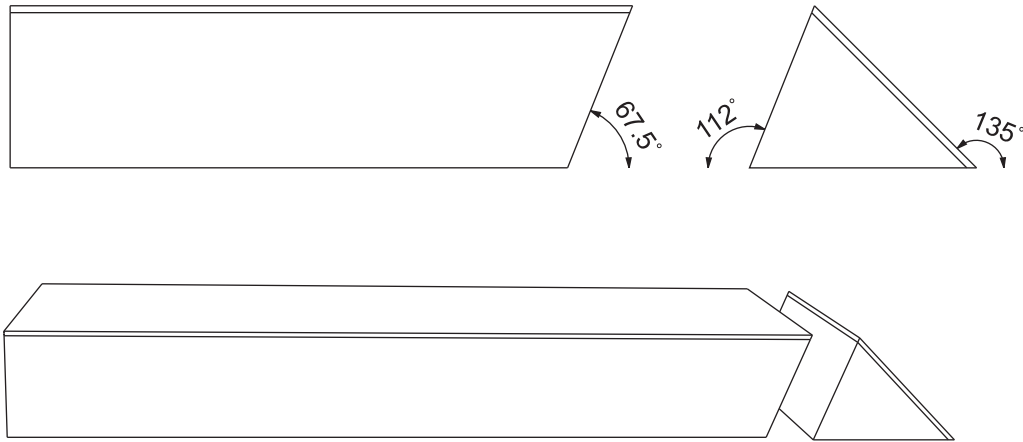
figure 1

- Where the length to be installed exceeds the length of the material supplied (12'), splice two or more lengths together as required to cover span. Scarf or miter joints are recommended for optimum fit. Cut the adjoining wall base pieces at opposite 45° angles to join them together (see **figure 2**).

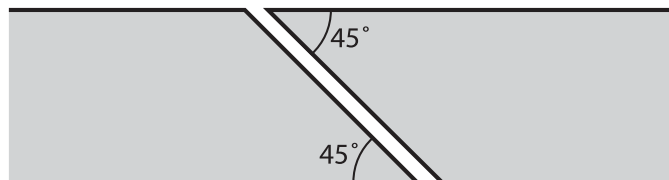
figure 2

- Apply construction adhesive to the back side of the wall base.
- Apply the wall base to the wall using the level line to align the top edge of the wall base.
- At each marked stud location, use a nail gun with 2" finish nails to firmly fasten the wall base while the adhesive cures.
- Finish all ends with closed mitered caps. All end caps should be finished with a closed miter cap, resulting in a 45° tapered return to the wall. Use construction adhesive and 1" long finish nails to firmly secure all mitered ends and corners.
- Clean away excess adhesive with clean, damp cloth or sponge.

- l. Wherever the wall base wraps around an outside corner in the wall, a corner protector piece must be applied to provide additional protection at the miter joint. With a corner protector placed on a drop cloth with the inside angle (side that goes against the wall) facing up, apply a heavy coat of "Spray 90" spray-on contact adhesive (supplied with your order). While the adhesive is still bubbling, apply the corner protector to the wall base at the miter joint in the outside corner, then quickly remove it. The intent is to transfer sufficient adhesive from the corner protector to the wall base so that both surfaces are fully coated with adhesive. (Adhesive could be applied directly to the wall base, but the above method is designed to prevent over-spray from getting on the surrounding wall surface.) Repeat the process if both surfaces are not fully coated. Wait a few minutes until the contact adhesive sets up. Once it is dry but still tacky, position the corner protector on the wall base so the top and bottom edges match up with the edges on the wall base. Press the corner protector firmly into place until it is completely bonded to the wall base.
- m. Apply a thin bead of the color-matched caulk supplied with your order to any miter joints to provide a seamless transition. Wipe away excess caulk with a clean, damp cloth or sponge.
- n. Fill all nail holes with color-matched caulk. Wipe away excess caulk with a clean, damp cloth or sponge.

3. Install the Base Shoe (if applicable)

- a. Measure the section of wall base to be covered by the base shoe.
- b. Determine the desired set-back from the ends of the wall base, if any.
- c. Subtract the necessary set-backs from the overall measurement of the section to get the measurement of the base shoe length from one end to the next end.
- d. Base shoe ends can be finished either with partial miters or closed mitered ends. All inside and outside corners should be mitered with 45° cuts.
- e. Apply construction adhesive to the back of the base shoe.
- f. Begin installing the base shoe at one end and apply to the bottom edge of the wall base. DO NOT attempt to nail shoe molding with pneumatic nail guns. If further fastening strength is required due to inconsistencies in the floor, pre-drill shoe molding with $\frac{1}{16}$ " drill bit and hand fasten with standard #4 finish nails.

Cleaning:

1. Polish out any scratches in the surface of the wall base using '0000' fine steel wool.
2. Wipe down the entire surface with a soft, clean cloth.