

Viking Use & Care Manual



Viking Range Corporation
111 Front Street
Greenwood, Mississippi 38930 USA
(662) 455-1200

For product information
call 1-888-VIKING1 (845-4641)
or visit the Viking Web site at
vikingrange.com

Designer Series
Built-In Warming Drawer

Congratulations

Your purchase of this product attests to the importance you place upon the quality and performance of the major appliances you use. With minimal care, as outlined in this guide, this product is designed to provide you with years of dependable service. Please take the few minutes necessary to learn the proper and efficient use and care of this quality product.

We appreciate your choosing a Viking Range Corporation product, and hope that you will again select our products for your other major appliance needs.

Table of Contents

Important Safeguards	2
Warming Drawer Features	4
Operation	4
Temperature Control	6
Power "ON" Light	7
Moisture Selector Control	7
Temperature and Moisture Guidelines	8
Cleaning and Maintenance	9
Service Information	11
Warranty	12

IMPORTANT Safety instructions

WARNING: To reduce the risk of fire, electric shock, or injury to persons when using your appliance, follow basic precautions, including the following:

1. Read all instructions before using the warming drawer.
2. Be sure the warming drawer is properly installed and grounded by a qualified technician.
3. Do not touch the heating elements or interior surface of the drawer while it is in use. Use handles or knobs.
4. Do not leave children alone or unattended in an area where appliances are in use. Close supervision is necessary when any appliance is used by or near children.
5. Do not repair or replace any part of this drawer. All servicing should be done by an authorized service agency or representative. Do not tamper with the controls.

6. **Do Not** store flammable materials in the drawer.
7. Use only dry potholders. If moist or damp potholders are used, steam from potholders could cause a steam burn. Do not let potholders touch hot heating elements located under the drawer. Do not use a towel or bulky cloths in place of potholders.
8. Wear proper apparel - Loose fitting or hanging garments should never be worn while using the appliance.
9. Use care when opening the drawer. Let hot air or steam escape (open vent) before removing or replacing food.
10. Do not place food in unopened containers in the drawer. Pressure could build up and cause the container to burst.
11. Never use the appliance for other than intended use.
12. Do not use water on grease fires. Smother fire or flame or use dry chemical or foam-type extinguisher.
13. Do not use aluminum foil to line the drawer. It is an excellent heat insulator and will trap heat beneath it. This will upset the performance and can damage the interior finish.
14. Keep warming drawer vent ducts unobstructed.
16. Keep drawer closed when not in use.
16. Placement of warming racks - Always place racks in desired position while drawer is cool. If racks must be moved while warming drawer is hot, do not let potholder contact heating elements.
17. Do not heat articles that have been previously cleaned in, washed in, or spotted with gasoline, dry-cleaning solvents, or other flammable or explosive substances, as they give off vapors that could ignite or explode.
18. Do not place items exposed to cooking oils in your warming drawer. Items contaminated with cooking oils may contribute to a chemical reaction that could cause a load to catch fire.
19. Do not use heat on articles containing foam rubber or similarly textured rubber-like materials.
20. Do not install or store units where they will be exposed to the weather.

- SAVE THESE INSTRUCTIONS -

Warming Drawer Features

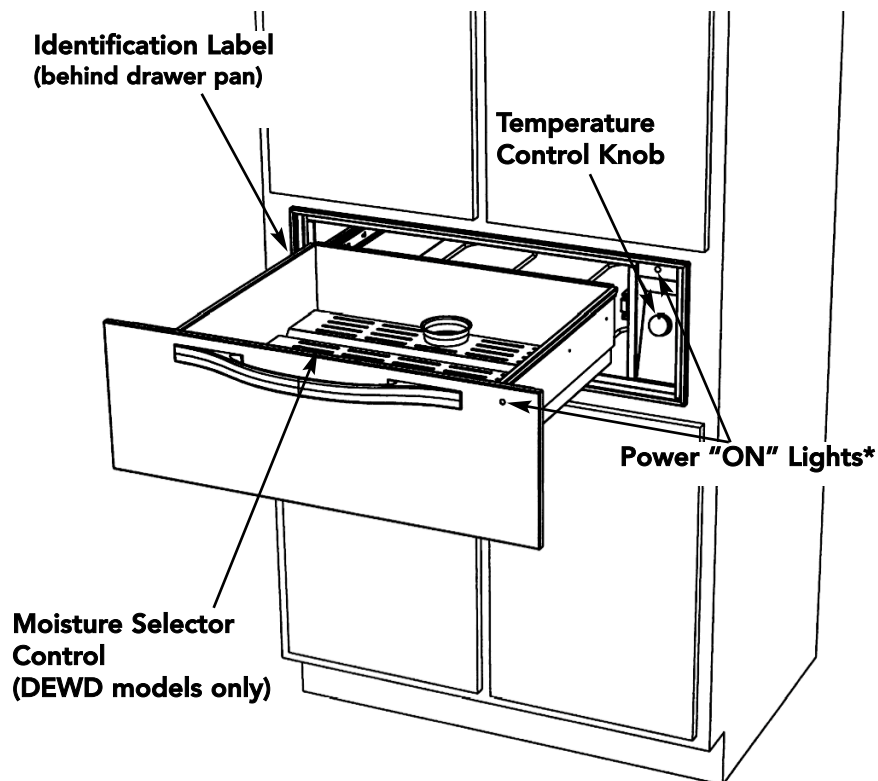

*The DEWD model has a power "ON" indicator light located on both the control panel and the door front. The DFWD model only has a power "ON" indicator light located on the control panel.

Operation

Your warming drawer works in two ways:

1. Sealing moisture within the drawer to keep food moist
2. Allowing the moisture to escape and keep food crisp

The purpose of the warming drawer is to hold hot cooked foods at serving temperature. Always start with hot food; cold food cannot be heated in the warming drawer.

Heating Options:

A. Moist Heat

This prevents food from drying out, since moisture, as well as heat, is applied to the warming chamber.

1. Your warming drawer comes with two low racks and a moisture cup. One low rack has an opening in the rear center for the moisture cup. Place low racks in warming drawer. Fill the moisture cup approximately half full with water. (Should use approximately 1/2" cup water). Place the moisture cup in the opening in the rear center of the low rack.
2. Place the food directly on the rack or you can use any pans that will fit in the warming drawer. The rack supports the food off of the steam vents where slight amounts of moisture may appear.
3. Open the front moisture selector control located on the DEWD models half-way. (See moisture selector section on page 7.) Additional adjustments to the control may become necessary depending upon the type and amount of food stored in the drawer, the number of times the drawer is opened per hour, and the temperature setting.

B. Dry Heat (DEWD Models only)

For some applications you may want to store previously prepared foods in a "dry heat" environment. This can be easily accomplished by placing the food directly into the empty drawer pan and sliding the moisture control selector to open. This allows the moist heat to escape and provides a dry environment for the food.

C. Optional Accessories for Moist or Dry Heat

Pans / Lids - This warming drawer is designed to accommodate standard size pan inserts. The optional pan/lid set consists of one 4" D. x 12" L. x 10 1/2" W. pan/lid, two 4" D. x 12" L. x 7" W. pans/lids, and two 2 1/2" D. x 12" L. x 7" W. pans/lids.

Low Rack with Moisture Cup

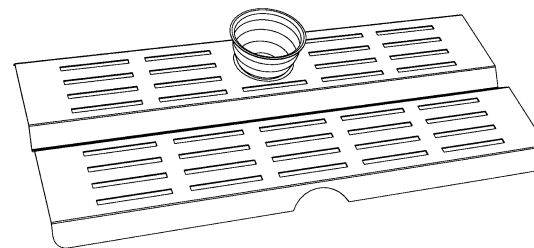

Pans/Lids

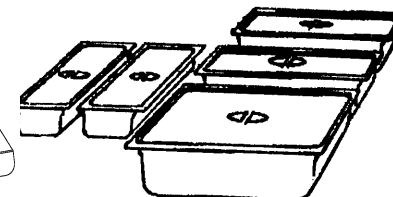

Temperature Control

The temperature control knob is used to select the temperature of the drawer and is located on the right side of the control panel. The 1 setting located on the control panel represents low, 2 represents medium and 3 represents high. The majority of foods are held at a medium setting to maintain a serving temperature. However, your own preference may be for hotter foods.

To keep several types of food hot for serving, use the temperature setting for the meat. For example, to hold rare roast beef, select a lower setting, cover the other foods that otherwise would be kept at a higher setting.

Repeated opening of the drawer allows the hot air to escape and the food to cool. The drawer should not be opened unless adding or removing food.

Temperature Setting Ranges

Low	100°F (37.7°C) - 125°F (51.7°C)
Medium	175°F (79.4°C) - 200°F (93.3°C)
High	225°F (107.2°C) - 250°F (121.1°C)

Proofing

Yeast dough can be proofed in the warming drawer. Place the dough in a bowl. Place the bowl on the low rack in the drawer. Fill the moisture cup half full with water and place in the opening in the rear center of the low rack. Turn the temperature control to the lowest setting to facilitate the fermentation time. On the DEWD models, place the moisture control setting to the closed "+" position. A towel should be placed over the dough to minimize surface drying. The dough should remain in the warming drawer until it has doubled in size and a slight depression remains when the surface is touched gently with a finger.

Warming Plates

To warm serving bowls and plates, place temperature control on a low setting. Place the empty dishes on the low rack to raise them off the bottom of the drawer. If you want hotter dishes or want to heat fine china, please check with the manufacturer of the dishes for their maximum heat tolerance.

Power "ON" Lights

The power "on" indicator lights on the DEWD models are located on the outer door panel and above the temperature control knob. It turns on when the control knob is set and cycles on and off with the heating element as temperature is maintained. On the DFWD models, there is only one power "ON" indicator light located above the temperature control knob.

Moisture Selector Control (DEWD Models only)

The moisture selector control is located at the top of the warming drawer. To keep foods moist, move the knob to the right. This closes the vents and seals the moisture inside the drawer. For crisp foods, move the knob to the left. This opens the vents and allows the moisture to escape. The moisture selector can be placed in any position between "-" (open for less moisture) and "+" (closed to retain moisture) to maintain any degree of moisture.

In the closed position, the drawer is completely sealed which keeps the hot foods moist and soft. In this setting, condensation may be noticed around the inside edge of the drawer. If the drawer is not full, there may be some drying on the surface of the food. If this happens, simply cover the food with a lid or aluminum foil.

When in the open position, the drawer is vented, which lets moisture escape. This dry heat keeps the foods exterior dry and crisp. With the vents open, it is normal for moisture to collect on surfaces above the warming drawer. Simply wipe up the moisture with a dry cloth.

CAUTION

Do not use plastic wrap to cover foods placed in the drawer, nor to keep foods warm that are wrapped or placed in plastic containers for heating. Plastics can melt onto the drawer if they are in direct contact. If melted onto the drawer, they can be very difficult to remove.

Temperature and Moisture Guidelines

The information below is given as a guide only. You may need to vary the heat settings to suit your personal requirements.

Food	Temperature Settings	Moisture Settings (dewd models only)
Bacon	2 - 3	-
Beef, medium and well done	2	+
Beef, rare	1 - 2	+
Bread, hard roll	2	-
Bread, soft rolls	2	-
Casseroles	2	+
Cooked cereal	2	+
Dough, proofing	1	+
Eggs	2	+
Fish, seafood (baked)	2	+
Fried foods	3	-
Fruit	2	+
Gravy, creamed sauces	2	+
Ham	2	+
Pancakes, waffles	2 - 3	+
Pies, one crust	2	+
Pies, two crust	2	-
Pizza	2 - 3	halfway
Pork	2	+
Potatoes, baked	3	halfway
Potatoes, mashed	2	+
Poultry	2 - 3	+
Vegetables	2	-

Cleaning and Maintenance

Make sure the control knob is in the "OFF" position before cleaning.

1. Allow warming drawer to cool completely.
2. It is important to keep the slide rails clear and free from debris. Periodic cleaning of slide rails and other adjoining parts is necessary to assure smooth drawer operation.
3. If needed, the warming drawer pan support can be removed for cleaning. Pull the warming drawer out until fully extended. Slide finger along right and left side rail until you reach hand latches (located at the front of rails). Pull up on both right and left latches. Pull drawer support completely out.

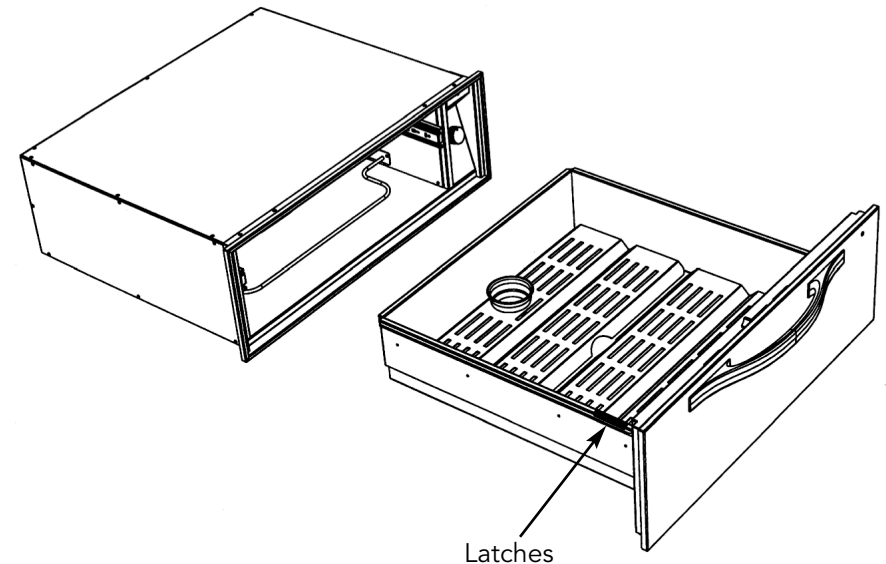

CAUTION

Do not use any cleaning agent with chlorine or chlorine compounds on stainless steel finish. Chlorine and chlorine compounds are corrosive to stainless steel.

CLEANING CHART

Material	Cleaning Products	Directions
Stainless Steel / Enamels	Mild cleaners	Sponge with cloth, then rinse with clear water and wipe dry. Satisfactory for use on all finishes.
Plastic (Control Knob)	Soap and water	Pull off knob. Wash, but do not soak. Rinse with water, dry and replace on control.

When cleaning hard water spots and scales, use a vinegar and water solution. Swab or wipe with cloth. Rinse with clear water and dry. If the spots remain after using vinegar and water, a soft, non-abrasive cleaner can be used. Apply with damp sponge or cloth. Satisfactory for use on all finishes if rubbing is light. Always rub in the direction of the polish lines.

Service Information

If your warming drawer should fail to operate:

1. Have you read and followed the instructions provided?
2. Is the circuit breaker open, or is a fuse blown?

If service is required:

1. Call your dealer or authorized service agency. The name of the authorized service agency can be obtained from the dealer or distributor in your area.
2. Have the following information readily available:
 - a. Model number
 - b. Serial number
 - c. Date purchased
 - d. Name of dealer from whom purchased
3. Clearly describe the problem that you are having.

If you are unable to obtain the name of an authorized service agency, or if you continue to have service problems, contact Viking Range Corporation at (662) 451-4133 or write to:

VIKING RANGE CORPORATION PREFERRED SERVICE

111 Front Street
Greenwood, Mississippi (MS) 38930 USA

Record the information indicated below. You will need it if service is ever required. The model and serial number for your warming drawer are located on the left side of the drawer housing on an identification label. Pull out drawer for access.

Model Number _____ Serial Number _____

Date of Purchase _____ Date Installed _____

Dealer's Name _____

Address _____

If service requires installation of parts, use only authorized parts to ensure protection under the warranty.

PLEASE RETAIN THIS MANUAL FOR FUTURE REFERENCE.

DESIGNER SERIES
BUILT-IN ELECTRIC WARMING DRAWER WARRANTY
ONE YEAR FULL WARRANTY

Built-in electric warming drawers and all of their component parts, except as detailed below*, are warranted to be free from defective materials or workmanship in normal household use for a period of twelve (12) months from the date of original retail purchase. Viking Range Corporation, warrantor, agrees to repair or replace, at its option, any part which fails or is found to be defective during the warranty period.

*Painted and decorative items are warranted to be free from defective materials or workmanship for a period of ninety (90) days from the date of original retail purchase. ANY DEFECTS MUST BE REPORTED TO THE SELLING DEALER WITHIN NINETY (90) DAYS FROM DATE OF ORIGINAL RETAIL PURCHASE.

Viking Range Corporation uses the most up-to-date processes and best materials available to produce all color finishes. However, slight color variation may be noticed because of the inherent differences in painted parts and porcelain parts as well as differences in kitchen lighting, product locations, and other factors.

FIVE YEAR LIMITED WARRANTY

Any heating element which fails due to defective materials or workmanship in normal household use during the second through fifth year from the date of original retail purchase will be repaired or replaced, free of charge for the part itself, with the owner paying all other costs, including labor.

NINETY (90) DAY RESIDENTIAL PLUS WARRANTY This warranty applies to applications where use of the product extends beyond normal residential use. Examples are, but not limited to, bed and breakfasts, fire stations, private clubs, churches, etc. This warranty excludes all commercial locations such as restaurants, food service locations and institutional food service locations.

This warranty extends to the original purchaser of the product warranted hereunder and to each transferee owner of the product during the term of the warranty.

This warranty shall apply to products purchased and located in the United States and Canada. Products must be purchased in the country where service is requested. Warranty labor shall be performed by an authorized Viking Range Corporation service agency or representative. Warranty shall not apply to damage resulting from abuse, accident, natural disaster, loss of electrical power to the product for any reason, alteration, outdoor use, improper installation, improper operation, or repair or service of the product by anyone other than an authorized Viking Range Corporation service agency or representative. This warranty does not apply to commercial usage. Warrantor is not responsible for consequential or incidental damage whether arising out of breach of warranty, breach of contract, or otherwise. Some jurisdictions do not allow the exclusion or limitation of incidental or consequential damages, so the above limitation or exclusion may not apply to you.

Owner shall be responsible for proper installation, providing normal care and maintenance, providing proof of purchase upon request, and making the appliance reasonably accessible for service. If the product or one of its component parts contains a defect or malfunction during the warranty period, after a reasonable number of attempts by the warrantor to remedy the defects or malfunctions, the owner is entitled to either a refund or replacement of the product or its component part or parts. Warrantor's liability on any claim of any kind, with respect to the goods or services covered hereunder, shall in no case exceed the price of the goods or service or part thereof which gives rise to the claim.

WARRANTY SERVICE: Under the terms of this warranty, service must be performed by a factory authorized Viking Range Corporation service agent or representative. Service will be provided during normal business hours, and labor performed at overtime or premium rates shall not be covered by this warranty. To obtain warranty service, contact the dealer from whom the product was purchased, an authorized Viking Range Corporation service agent, or Viking Range Corporation. Provide model and serial number and date of original purchase. For the name of your nearest authorized Viking Range Corporation service agency, call the dealer from whom the product was purchased or Viking Range Corporation. **IMPORTANT:** Retain proof of original purchase to establish warranty period.

The return of the Owner Registration Card is not a condition of warranty coverage. You should, however, return the Owner Registration Card so that Viking Range Corporation can contact you should any question of safety arise which could affect you.

Any implied warranties of merchantability and fitness applicable to the above described heating element are limited in duration to the period of coverage of the applicable express written limited warranties set forth above. Some jurisdictions do not allow limitations on how long an implied warranty lasts, so the above limitation may not apply to you. This warranty gives you specific legal rights, and you may also have other rights which may vary from jurisdiction to jurisdiction.

