

# Surface Operation

## Lighting the Burners

All burners are ignited by electric ignition. There are no open-flame, "standing" pilots.

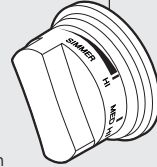

## Vari-Simmer™

Simmering is a cooking technique in which foods are cooked in hot liquids kept at or just barely below the boiling point of water. Simmering ensures gentler treatment than boiling to prevent food from toughening and/or breaking up. The size of the pan and the volume of food can have a significant effect on how high or low a flame is needed for simmering. For this reason, Viking range and rangetop burners are engineered with a Vari-Simmer setting. The Vari-Simmer setting is not just one simmer setting, but provides a variable range of simmer settings. This variable range of simmer settings allows you to adjust the flame height to achieve the best simmer depending on the type and quantity of food being simmered. It is this ability that makes the Vari-Simmer setting the most accurate and trustworthy simmer on the market.

## Power Plus Burner™ (where applicable)

Certain model ranges are equipped with a Power Plus 18,500 BTU burner in the front right burner position. This burner is designed to provide extra high heat output, especially when using large pans, and should be used for boiling large quantities or if you need to bring something to a boil quickly. While Power Plus burner has the extra power needed to bring large quantities of liquid to a boil rapidly, it is also able to be turned down low enough to provide a very low and delicate simmer making this burner the most versatile burner on the market.

## Griddle/Simmer Plate (where applicable)

The optional 15,000 BTU griddle is constructed of machined steel with a blanchard finish and is uniquely designed to offer excellent cooking performance as well as easy clean up. The griddle is equipped with an electronic thermostat to maintain an even temperature across the griddle once the desired temperature has been set. The griddle has a power "ON" indicator light which glows when the griddle thermostat has been turned on. This will cycle on and off as needed to indicate the thermostat is maintaining the selected temperature. Before the griddle is used, it is important to season the griddle. See instructions in the Use & Care for steps on seasoning the griddle.

## Char-Grill (where applicable)

The optional 18,000 BTU char-grill is equipped with a single piece, heavy-duty porcelainized cast-iron grill grate for easy movement of grilling items. Beneath the grill grate are two slotted porcelainized flavor generator

plates which are designed to catch drippings and circulate a smoke flavor back into the food. Beneath the flavor generator plates is a two piece drip pan which catches any drippings that might pass beyond the flavor generator plates. This unique grilling system is designed to provide outdoor quality grilling indoors.

## Griddle/Simmer Plate, Bake Burner, Infrared Burner

Turning the thermostat counter clockwise to any "ON" position activates an igniter and opens an electromechanical valve in the system to start the gas valve. The griddle has a power "ON" light which glows when the griddle thermostat is turned on. The light cycles on and off with the burner. It is not possible to use both the infrared burner and the bake burners at the same time. The design of the system will not permit this, both for control of bake/broiler and for safety of use.

# Oven Functions

## Preheat

For best results, it is extremely important that you preheat your oven to the desired cooking temperature before placing food items in the oven to begin cooking. In many cooking modes, partial power from the broiler is used to bring the oven to the preheat temperature. Therefore, placing food items in the oven during the preheat mode is not recommended.

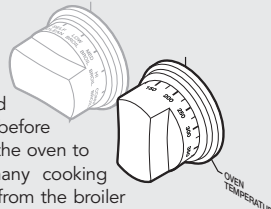

- **BAKE (Natural Airflow Bake)**  
Use this setting for baking, roasting, and casseroles.

- **CONVECTION BAKE**  
Use this setting to bake and roast foods at the same time with minimal taste transfer.

- **BROIL (Infrared Broil)**  
Use this setting for broiling dark meats at 1" thickness or less where rare or medium doneness is desired.

- **CONVECTION BROIL (Infrared Convection Broil)**  
Use this setting to broil thick cuts of meat.

- **Convection Dehydrate**  
Use this function to dehydrate fruits and vegetables.

- **Convection Defrost**  
Use this function to defrost foods.

# Range Controls

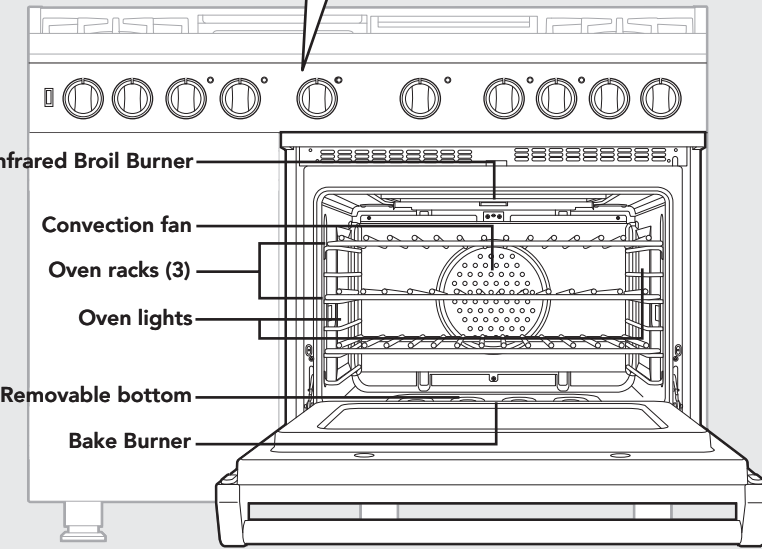
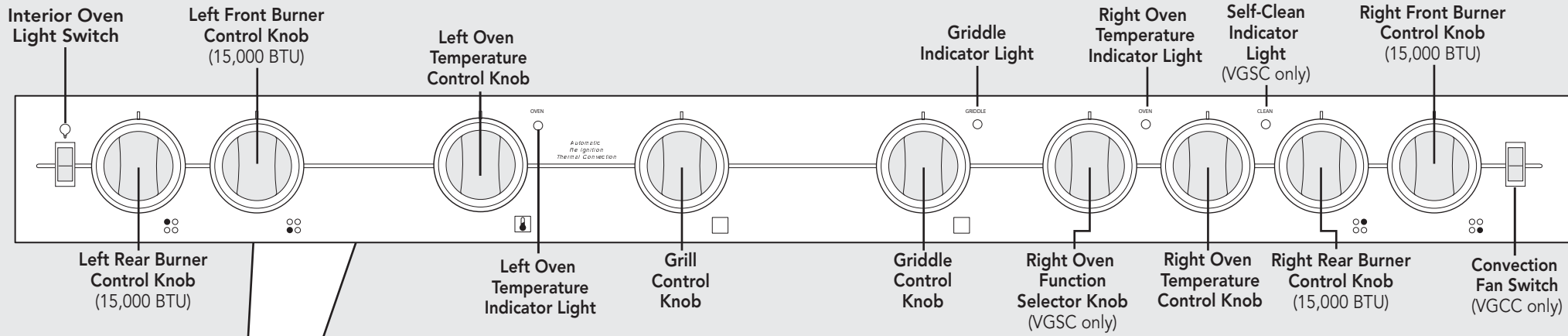

Note: 48" 4-Burner/Griddle/Grill model shown

## Surface Heat Settings\*

### Vari-Simmer™

Melting and simmering small quantities, steaming rice, and sauces

### HI

Boiling water quickly, deep-fat frying in large utensil

### MED HI

Maintaining fast boil on large quantities, high temperature frying, and pan broiling

### MED

Maintaining slow boil on large quantities, sauteing, browning, braising and pan-frying

### MED LOW

Simmering large quantities, low temperature frying (eggs, etc.), heating milk, cream sauces, gravies, and pudding

### LOW

Melting large quantities

\*Note: The above information is given as a guide only. You may need to vary the heat settings to suit your personal requirements.

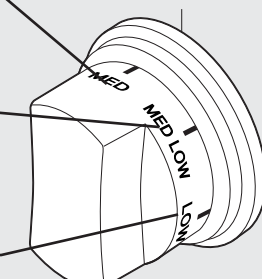
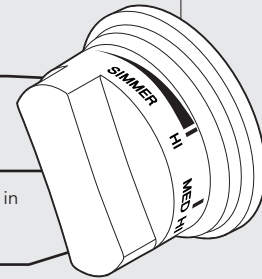

## Griddle/Simmer Plate Operation/Settings

- Turn the griddle control knob to desired temperature setting.
- **ALWAYS** turn off when not in use, or lower the heat between cooking loads.

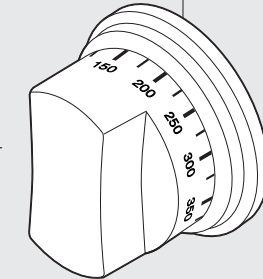

## Grill Operation/Settings

- Turn on ventilator (separate product).
- Turn control knob to HI.
- Preheat on HI for 5 to 10 minutes.
- Place food on grill, cook as desired.

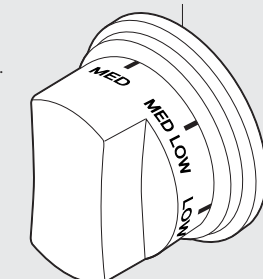

# Oven Settings

## BAKE (Natural Airflow Bake)

Full power heat is radiated from the U-shaped bake burners in the bottom of the oven cavity and is circulated with natural airflow. This function is recommended for single rack baking. Many cookbooks contain recipes to be cooked in the conventional manner. Conventional baking is suitable for dishes that require a high temperature. Use this setting for baking and casseroles.

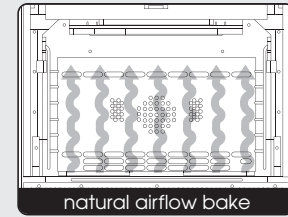

## CONVECTION BAKE

Heat is radiated from the U-shaped bake burners in the bottom of the oven cavity. The heated air is circulated by one motorized fan in the rear of the oven providing a more even heat distribution. Multiple rack use is possible for the largest baking job. When roasting, cool air is quickly replaced—searing meats on the outside and retaining more juices and natural flavor on the inside with less shrinkage. This even circulation of air equalizes the temperature throughout the oven cavity and eliminates the hot and cold spots found in conventional ovens.



## BROIL (Infrared Broil)

The broil burner at the top of the oven heats the metal screen until it glows. Heat radiates from the GourmetGlo™ infrared broiler located at the top of the oven cavity. The distance between the foods and the broil elements determines broiling speed. For "fast" broiling, food may be as close as 2 inches (5 cm) to the broil element or on the top rack. "Fast" broiling is best for meats where rare to medium doneness is desired. Use this setting for broiling small and average cuts of meat.

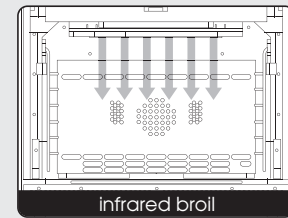

## CONVECTION BROIL (Infrared Convection Broil)

The top burner operates at full power. This function is exactly the same as regular broiling with the additional benefit of air circulation by the motorized fan in the rear of the oven. Smoke is reduced since the airflow also reduces peak temperatures on the food. Use this setting for broiling thick cuts of meats.

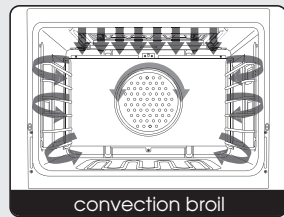

## Convection Dehydration

This oven is designed not only to cook, but also to dehydrate fruits and vegetables.

1. Prepare the food as recommended.
2. Arrange the food on drying racks (not included with the oven; contact a local store handling specialty cooking utensils).
3. VGSC models—Set the temperature control to 200°F (93.3°C) and turn the selector to "CONVECTION BAKE". VGCC models—Set the temperature control to 200°F (93.3°C) and turn on the convection fan switch.

## Convection Defrost

1. Place the frozen food on a baking sheet.
2. Set the temperature control to "OFF".
3. VGSC models—Turn the selector to "CONVECTION BAKE" and set the temperature to "OFF". VGCC models—Set the oven temperature control knob to "OFF" and turn on the convection fan switch.

## Self-Clean Cycle (VGSC Models Only)

This range features a self-cleaning cycle. During this cycle, the oven reaches elevated temperatures in order to burn off soil and deposits. A powder ash residue is left in the bottom of the oven after completion of the self-clean cycle. See *Use and Care Manual* for self-clean cycle instructions.

# Warnings

Warning and Important Safety Instructions appearing in this manual are not meant to cover all possible conditions and situations that may occur. Common sense, caution, and care must be exercised when installing, maintaining, or operating the appliance.

ALWAYS contact the manufacturer about problems or conditions you do not understand.

## Recognize Safety Symbols, Words, Labels

 <b>DANGER</b>
Hazards or unsafe practices which <b>WILL</b> result in severe personal injury or death
 <b>WARNING</b>
Hazards or unsafe practices which <b>COULD</b> result in death severe personal injury or death
 <b>CAUTION</b>
Hazards or unsafe practices which <b>COULD</b> result in minor personal injury.
All safety messages will identify the hazard, tell you how to reduce the chance of injury, and tell you what can happen if the instructions are not followed.

Read and follow all instructions before using this appliance to prevent the potential risk of fire, electric shock, personal injury or damage to the appliance as a result of improper usage of the appliance. Use appliance only for its intended purpose as described in this manual.

**To ensure proper and safe operation:** Appliance must be properly installed and grounded by a qualified technician. **DO NOT** attempt to adjust, repair, service, or replace any part of your appliance unless it is specifically recommended in this manual. All other servicing should be referred to a qualified servicer. Have the installer show you the location of the gas shutoff valve and how to shut it off in an emergency.

## Important Safety Notice and Warning

The California Safe Drinking Water and Toxic Enforcement Act of 1986 (Proposition 65) requires the Governor of California to publish a list of substances known to the State of California to cause cancer or reproductive harm, and requires businesses to warn customers of potential exposures to such substances. Users of this appliance are hereby warned that when the oven is engaged in the self-clean cycle, there may be some low-level exposure to some of the listed substances, including carbon monoxide. Exposure to these substances can be minimized by properly venting the oven to the outdoors by opening the windows and/or door in the room where the appliance is located during the self-clean cycle.

### Important notice regarding pet birds:

**NEVER** keep pet birds in the kitchen or in rooms where the fumes from the kitchen could reach. Birds have a very sensitive respiratory system. Fumes released during an oven self-cleaning cycle may be harmful or fatal to birds. Fumes released due to overheated cooking oil, fat, margarine and overheated non-stick cookware may be equally harmful.

## About Your Appliance

 <b>WARNING</b>
<b>NEVER</b> use appliance as a space heater to heat or warm a room to prevent potential hazard to the user and damage to the appliance. Also, <b>DO NOT</b> use the rangetop or oven as a storage area for food or cooking utensils.

- For proper oven performance and operation, **DO NOT** block or obstruct the oven vent duct located on the right side of the air grille.
- Avoid touching oven vent area while oven is on and for several minutes after oven is turned off. When the oven is in use, the vent and surrounding area become hot enough to cause burns. After oven is turned off, **DO NOT** touch the oven vent or surrounding areas until they have had sufficient time to cool.
- Other potentially hot surfaces include rangetop, areas facing the rangetop, oven vent, surfaces near the vent opening, oven door, areas around the oven door and oven window.
- The misuse of oven doors (e.g. stepping, sitting, or leaning on them) can result in potential hazards and/or injuries.

# Warnings (cont.)

 <b>WARNING</b>
This range features a self-cleaning cycle. During this cycle, the oven reaches elevated temperatures in order to burn off soil and deposits. A powder ash residue is left in the bottom of the oven after completion of the self-clean cycle.
<b>Note: DO NOT use commercial oven cleaners inside the oven. Use of these cleaners can produce hazardous fumes or can damage the porcelain finishes. DO NOT line the oven with aluminum foil or other materials. These items can melt or burn during a self-clean cycle, causing permanent damage to the oven.</b>



 <b>CAUTION</b>
 <b>DO NOT</b> touch the exterior portions of the oven after self-cleaning cycle has begun, since some parts become extremely hot to the touch!
During the first few times the self-cleaning feature is used, there may be some odor and smoking from the "curing" of the binder in the high-density insulation used in the oven. When the insulation is thoroughly cured, this odor will disappear. During subsequent self-cleaning cycles, you may sense an odor characteristic of high temperatures.
<b>KEEP THE KITCHEN WELL-VENTED DURING THE SELF-CLEAN CYCLE.</b>

 <b>CAUTION</b>
You must carefully check the food during the dehydration process to ensure that it does not catch fire.



 <b>CAUTION</b>
 <b>BURN HAZARD</b>
When self-cleaning, surfaces may get hotter than usual. Therefore, children should be kept away.

 <b>CAUTION</b>
<b>DO NOT</b> store items of interest to children over the unit. Children climbing to reach items could be seriously injured.



 <b>WARNING</b>
<b>If the information in this manual is not followed exactly, a fire or explosion may result causing property damage, personal injury or death.</b>
WHAT TO DO IF YOU SMELL GAS: <ul style="list-style-type: none"> <li><b>DO NOT</b> try to light any appliance.</li> <li><b>DO NOT</b> touch any electrical switch.</li> <li><b>DO NOT</b> use any phone in your building.</li> <li>Immediately call your gas supplier from a neighbor's phone. Follow the gas supplier's instructions.</li> <li>If you cannot reach your gas supplier, call the fire department.</li> </ul>
Installation and service must be performed by a qualified installer, service agency or the gas supplier.



 <b>WARNING</b>
 <b>TIPPING HAZARD</b>
To reduce the risk of the appliance tipping, it must be secured by a properly installed anti-tip bracket(s). To make sure the bracket has been installed properly, look behind the range with a flashlight to verify proper installation engaged in the rear top left corner of the range. <ul style="list-style-type: none"> <li>THIS RANGE CAN TIP</li> <li>INJURIES TO PERSONS CAN RESULT</li> <li>INSTALL ANTI-TIP DEVICE PACKED WITH RANGE</li> <li>SEE INSTALLATION INSTRUCTIONS</li> </ul>

 <b>WARNING</b>
<b>DO NOT</b> use commercial oven cleaners inside the oven. Use of these cleaners can produce hazardous fumes or can damage the porcelain finishes.



 <b>WARNING</b>
 To avoid risk of property damage, personal injury or death; follow information in this manual exactly to prevent a fire or explosion. <b>DO NOT</b> store or use gasoline or other flammable vapors and liquids in the vicinity of this or any appliance.

# Warnings (cont.)

 <b>WARNING</b>
 <b>ELECTRICAL SHOCK HAZARD</b>
<b>DO NOT</b> touch a hot oven light bulb with a damp cloth as the bulb could break. Should the bulb break, disconnect power to the appliance before removing bulb to avoid electrical shock.

 <b>WARNING</b>
 <b>ELECTRICAL SHOCK HAZARD</b>
Disconnect the electric power at the main fuse or circuit breaker before replacing bulb.

 <b>WARNING</b>
 <b>BURN HAZARD</b>
The oven door, especially the glass, can get hot. <b>Danger of burning: DO NOT touch the glass!</b>

 <b>WARNING</b>
 <b>BURN OR ELECTRICAL SHOCK HAZARD</b>
Make sure all controls are OFF and oven is COOL before cleaning. Failure to do so can result in burns or electrical shock.

 <b>CAUTION</b>
To avoid sickness and food waste, <b>DO NOT</b> allow defrosted food to remain in the oven for more than two hours.

 <b>NOTICE</b>
<b>DO NOT</b> turn the Temperature Control on during defrosting. Turning the convection fan on will accelerate the natural defrosting of the food without the heat.

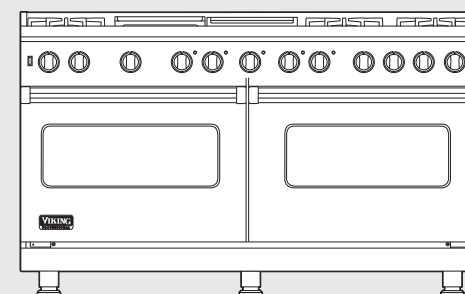
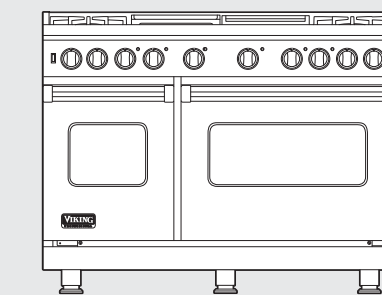
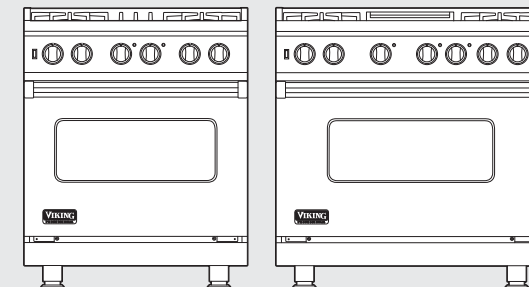

# Viking Quick Reference Guide

Professional Freestanding Gas & Gas Self-Clean Sealed Burner Ranges

