

TF 1160 W-26 w/WO26 Pitch-In Top

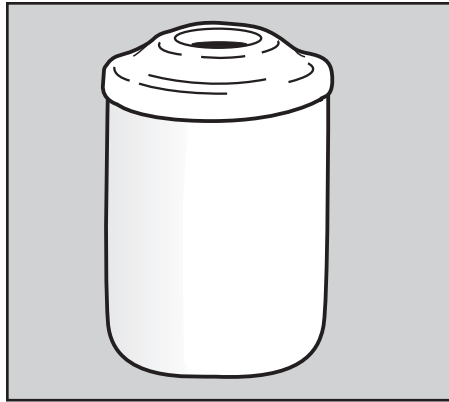

Options

(Note: Options may change without notice. Call to confirm current options.)

Exposed Aggregate:

Tan w/Gray Matrix - Misty Gray w/Gray

Weatherstone:

Sand - Gray - Brown - Buff - Cream
Light Charcoal - French Gray - Brick Red

Granitex

2078F, 4028F, 6208F, 1168F, 2098F

Custom Options Available

Size: 26" Dia. x 37" H.
Weight: 730 lbs.
Capacity: 42 gallons without liner.
31 gallons with liner.
Material: Reinforced Concrete.
Colors/Surfaces: See options.
Reinforcing: 3/8" & 1/4" Dia. steel rebar.
Wall Thickness: 2" at top with a 2% pitch.
Hardware: (4) - 1/2" Dia. elevator bolts, inserted on site.
(4) - 1/2" Dia. zinc alloy inserts.
(1) - 1/4" Dia. zinc alloy insert.
(2) - 5/8" Dia. lifting inserts.
Packaging: Palletized.
Maintenance: Occasionally rinse with water & mild detergent.
Re-seal annually.
Anchoring: Optional.
Logo Options: 16" Dia. x 1/4" Clear Lucite silk-screened with permanent inks. Installed with four tamper-proof rivets, or custom cast-in-place logo.

TF 1460 WO26 Pitch-In Top

Size: 26-1/2" Dia. x 5-1/2" H.
Weight: 6 lbs.
Material: Polyethylene plastic.
Color: Brown, Gray, Bronze.
(Colors may change without notice.)
Hardware: (1) - Security cable.
(1) - 1024 Hex head bolt.
(1) - Shouldered screw.
(1) - 1024 Washer.
(1) - Shouldered allen bolt.
Opening: 12-1/2" Dia.
Features: Made of recyclable plastic.
Maintenance: Clean with mild soap and water.
Packaging: Shipped in a carton.
Installation: Attach to container with security cable.

TF 1305 Large Retainer Ring Standard

Size: 24" Sq.
Weight: 1 lb.
Material: Zinc plated steel.
Features: Designed to hold "skirts" of polybag in container, out of view.
Packaging: In a carton.
Installation: Place polybag in container with edges draped over sides. Set ring on container rim, fold bag over ring into container.

TF 1625 Liner Optional

Size: 20" Dia. x 28" H.
Weight: 11 lbs.
Capacity: 31 gallons.
Material: Recycled polyethylene plastic.
Color: May vary.
Packaging: None.

WASTE CONTAINER SPECIFICATIONS

TF 1160 W-26 w/WO26 Pitch-In Top

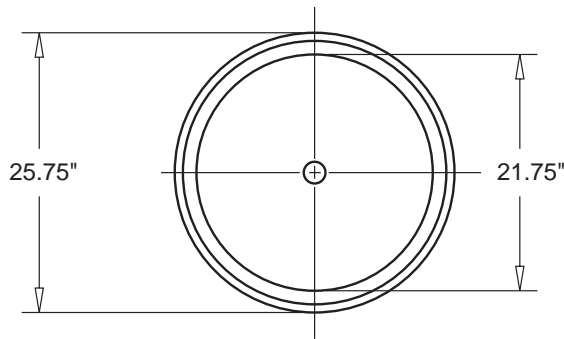

TOP VIEW

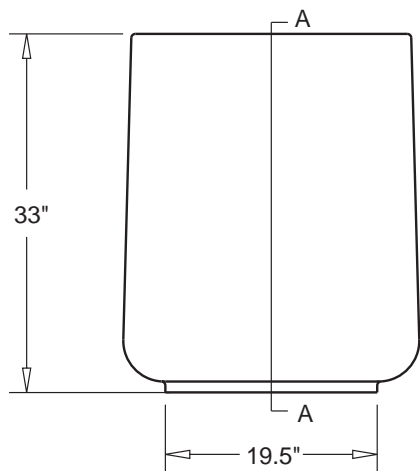

FRONT VIEW

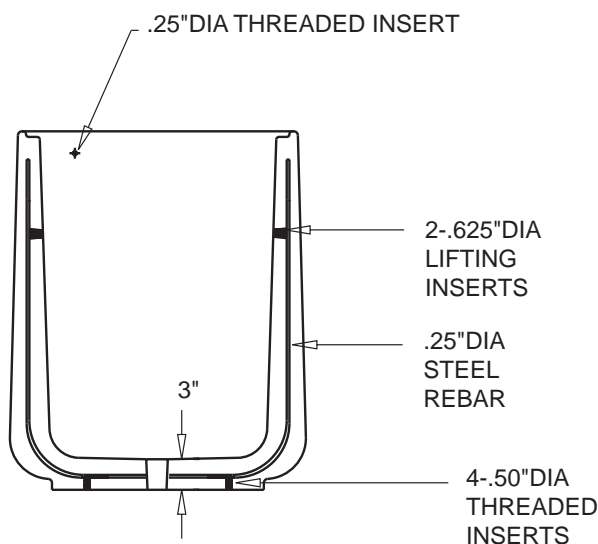

SECTION A-A

1.1 SUMMARY

- A. Section includes: Furnish Precast Concrete Waste Containers indicated on drawings or specified herein.

1.2 REFERENCES

- A. American Society for Testing & Materials
 1. ASTM C33
 2. ASTM C150
 3. ASTM C31

1.5 SUBMITTALS

- A. Submit product data, shop drawings and samples.
 1. Product Data: Manufacturer's specifications and technical data edited specifically for proposed system, including the following specific information:
 - a. Detailed specification of construction fabrication.
 - b. Manufacturer's installation instructions
 - c. Maintenance literature
 - d. Product warranty
 2. Shop Drawings: Indicate pertinent dimensions, general construction, component connections anchoring methods, hardware and installation procedures.
 3. Samples as requested by Architect.

1.6 QUALITY ASSURANCE

- A. Qualifications of Manufacturer: Manufacturer to be prequalified by specifier prior to bidding. Failure to comply will result in disqualification of bid. Manufacturer to have at least five years experience in the manufacturer of precast concrete waste containers field proven for at least five years.

1.10 WARRANTY

Manufacturer shall submit a written warranty for precast products for the period of two (2) years upon acceptance of products.

2.1 MANUFACTURERS

- A. Acceptable manufacturer for Precast Concrete Waste Containers to be known as:
Wausau Tile, Inc. Terra-Form Division.
PO Box 1520, Wausau, WI 54402-1520.
(800) 388-8728 FAX (715) 355-4627
- B. Clarification Note: Drawings and installation specification are based on manufacturers proprietary literature from Wausau Tile, Inc. Other manufacturers shall comply with minimum levels of material and detailing indicated on drawings or specified herein.
- C. All Precast products for this project shall be of one manufacturer.

2.2 MATERIALS

- A. Portland Cement: ASTM C150 specifications for Portland Cement.
- B. Aggregates: All aggregates to meet ASTM C33 specifications, to be cleaned of foreign matter and properly graded to size.
- C. Coloring: Pigments used shall be inorganic, resistant to alkalinity and used as per manufacturers recommendations.

#