

TF 1042 Woodgrain Waste Container



Options

(Note: Options may change without notice)

Weatherstone:

Sand - Gray - Brown - Buff - Cream
Light Charcoal - French Gray - Brick Red
Soulard Green

Custom Options Available

Size: 24" Sq. x 36" H (nominal)
Weight: 500 lbs
Capacity: 24 gallons with liner
Material: Reinforced Concrete
Colors/Surfaces: See options
Reinforcing: 1/4" and 3/8" Dia. steel rebar
Wall Thickness: 2 1/2" at top with 4 degree pitch
Hardware: (4) - 3/8" Dia. elevator bolts, inserted on site
(4) - 3/8" Dia. zinc alloy inserts
(1) - 1/4" Dia. zinc alloy insert
(2) - 5/8" Dia. lifting inserts
Packaging: Palletized
Maintenance: Occasionally rinse with water & mild detergent
Re-seal annually
Anchoring: Optional

TF 1467 Cast Aluminum Top

Size: 18" Sq.
Weight: 8 lbs.
Material: Cast Aluminum
Colors: Bronze - Black - Gray
Hardware: (1) - Security Cable
(2) - Shouldered allen bolt
Opening: 8" Sq.
Packaging: Shipped in carton
Maintenance: Clean with mild soap and water
Installation: Attach to container with security cable

TF 1610 Liner

Size: 14-7/8" Sq. x 29-7/8" H
Weight: 10 lbs.
Capacity: 24 gallons
Material: Recycled Polyethylene Plastic
Color: May Vary
Packaging: None

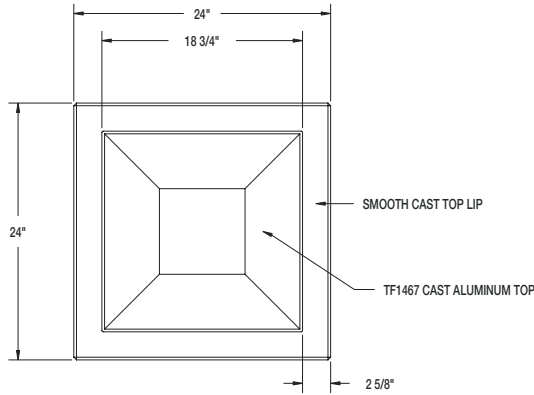

TOP VIEW

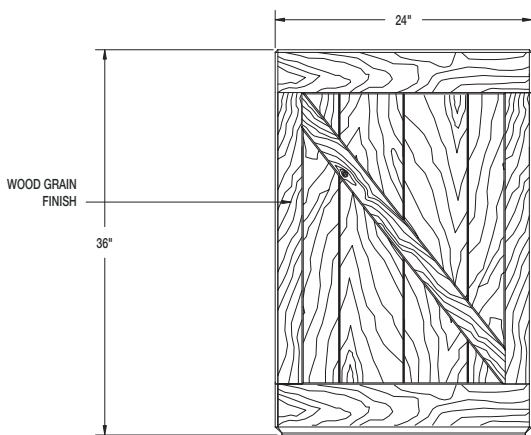

ELEVATION VIEW

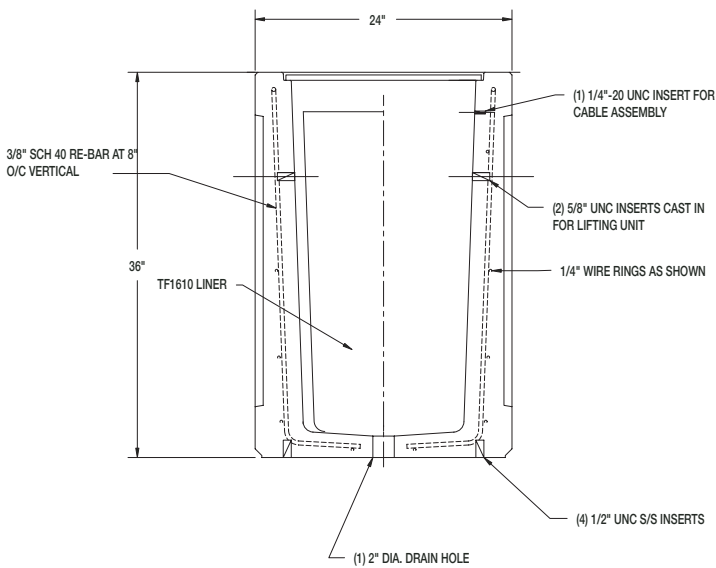

SECTION VIEW WASTE CONTAINER

1.1 SUMMARY

- A. Section includes: Furnish Precast Concrete Waste Containers indicated on drawings or specified herein.

1.2 REFERENCES

- A. American Society for Testing & Materials
 1. ASTM C33
 2. ASTM C150
 3. ASTM C31

1.5 SUBMITTALS

- A. Submit product data, shop drawings and samples.
 1. Product Data: Manufacturer's specifications and technical data edited specifically for proposed system, including the following specific information:
 - a. Detailed specification of construction fabrication.
 - b. Manufacturer's installation instructions
 - c. Maintenance literature
 - d. Product warranty
 2. Shop Drawings: Indicate pertinent dimensions, general construction, component connections anchoring methods, hardware and installation procedures.
 3. Samples as requested by Architect.

1.6 QUALITY ASSURANCE

- A. Qualifications of Manufacturer: Manufacturer to be prequalified by specifier prior to bidding. Failure to comply will result in disqualification of bid. Manufacturer to have at least five years experience in the manufacturer of precast concrete waste containers field proven for at least five years.

1.10 WARRANTY

Manufacturer shall submit a written warranty for precast products for the period of two (2) years upon acceptance of products.

2.1 MANUFACTURERS

- A. Acceptable manufacturer for Precast Concrete Waste Containers to be known as:
 Wausau Tile, Inc.
 PO Box 1520, Wausau, WI 54402-1520.
 (800) 388-8728 FAX (715) 355-4627
- B. Clarification Note: Drawings and installation specification are based on manufacturers proprietary literature from Wausau Tile, Inc. Other manufacturers shall comply with minimum levels of material and detailing indicated on drawings or specified herein.
- C. All Precast products for this project shall be of one manufacturer.

2.2 MATERIALS

- A. Portland Cement: ASTM C150 specifications for Portland Cement.
- B. Aggregates: All aggregates to meet ASTM C33 specifications, to be cleaned of foreign matter and properly graded to size.
- C. Coloring: Pigments used shall be inorganic, resistant to alkalinity and used as per manufacturers recommendations.

#