

TF 3050 TS50 Table

2/07

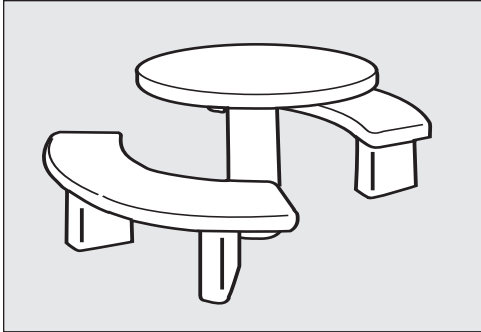

Options:

Note: Options may change without notice.
Call to confirm current options.

Exposed Aggregate Pedestal & Legs:

Tan Exp.
Misty gray Exp.

Ground & Polished (top & seats)

White Blend Terrazzo
Sand, Gray, Brown, Brick Red, Misty Gray

Glass

Clear - Emerald - Blue - Amber
Champaign - Charcoal

Custom Options Available



CAUTION

DO NOT OVER
TIGHTEN ANY BOLTS

Size:	72" Dia. x 30" H installed.
Weight:	1530 lbs.
Seating Capacity:	4 Persons plus wheelchair accessibility.
Material:	Reinforced Precast Concrete.
Colors:	See Options.
Reinforcing:	1/4" & 3/8" Dia. steel rebar.
Hardware:	(1) - 7" sq. x 1/8" rubber shim (4) - 1/2" Dia. set screws (8) - 3/8" x 16 x 1" Flat slotted screws (4) - 1/4" x 8 3/4" x 11 3/4" Aluminum plate drilled (16) - 3/8" Dia. x 1" Hex head bolt (16) - 3/8" Dia. flat washers (12) - 1/2" x 6" bent anchor bolt.
Top:	(1) - Top approx. 50" Dia. x 2".
Benches:	(2) - Benches 60" L x 14" W x 2" H.
Frames:	(1) - Pedestal (4) - Legs.
Assembly:	See assembly instructions
Maintenance:	Periodically rinse with water and mild detergent. Re-seal annually.
Packaging:	Packaged un-assembled in crate, and shrink wrapped in plastic.

*ADA Compliant

GENERAL SPECIFICATIONS

TF 3050 TS50 Table

1.1 SUMMARY

- A. Section includes: Furnish Precast Concrete Table indicated on drawings or specified herein.

1.2 REFERENCES

- A. American Society for Testing & Materials
 1. ASTM C33 2. ASTM C150 3. ASTM C31

1.5 SUBMITTALS

- A. Submit product data, shop drawings and Samples.
1. Product Data: Manufacturer's specifications and technical data edited specifically for proposed system, including the following specific information:
 - a. Detailed specification of construction fabrication.
 - b. Manufacturer's installation instructions
 - c. Maintenance literature
 - d. Product warranty
 2. Shop Drawings: Indicate pertinent dimensions, general construction, component connections anchoring methods, hardware and installation procedures.
 3. Samples as requested by Architect.

1.6 QUALITY ASSURANCE

- A. Qualifications of Manufacturer: Manufacturer to be prequalified by specifier prior to bidding. Failure to comply will result in disqualification of bid. Manufacturer to have at least five years experience in the manufacturer of precast concrete tables field proven for at least five years.

1.10 WARRANTY

Manufacturer shall submit a written warranty for precast products for the period of two years upon acceptance of products.

2.1 MANUFACTURERS

- A. Acceptable manufacturer for Precast Concrete Tables to be known as Wausau Tile, Inc.
 PO Box 1520, Wausau, WI 54402-1520.
 (800) 388-8728 FAX (715) 355-4627
- B. Clarification Note: Drawings and installation specification are based on manufacturers proprietary literature from Wausau Tile, Inc. Other manufacturers shall comply with minimum levels of material and detailing indicated on drawings or specified herein.
- C. All Precast products for this project shall be of one manufacturer.

2.2 MATERIALS

- A. Portland Cement: ASTM C150 specifications for Portland Cement.
- B. Aggregates: All aggregates to meet ASTM C33 specifications, to be cleaned of foreign matter and properly graded to size.
- C. Coloring: Pigments used shall be inorganic, resistant to alkalinity and used as per manufacturers recommendations.

#

