

# TF 2059 Westlake I Ash-N-Trash



- Size: 18" Dia. x 25" H.  
 Weight: 315 lbs.  
 Material: Reinforced Concrete.  
 Color/Surface: See Options.  
 (Colors may change without notice.)  
 Features: Part of Westlake series.  
 Recessed band of "carving".  
 Reinforcing: 1/4" Dia. steel rebar.  
 Hardware: (1) - brass drain screen.  
 (1) - 10 lb. bag Silica Sand.  
 (3) - 3/8" Dia. threaded inserts.  
 Anchoring: Optional.  
 Maintenance: Rinse with water & mild detergent.  
 Annual re-sealing recommended.  
 Packaging: Palletized.

## Options

(Note: Options may change without notice. Call to confirm current options.)

### Weatherstone:

Sand - Gray - Brown - Buff - Cream  
 Light Charcoal - French Gray - Brick Red

Custom Options Available

**Westlake Design** -- features an 6" carved band around the top 1/3 of the ash urn. Series I sports an ancient Egyptian design with a fern and floral background. These carvings are flush with the outside of the container.

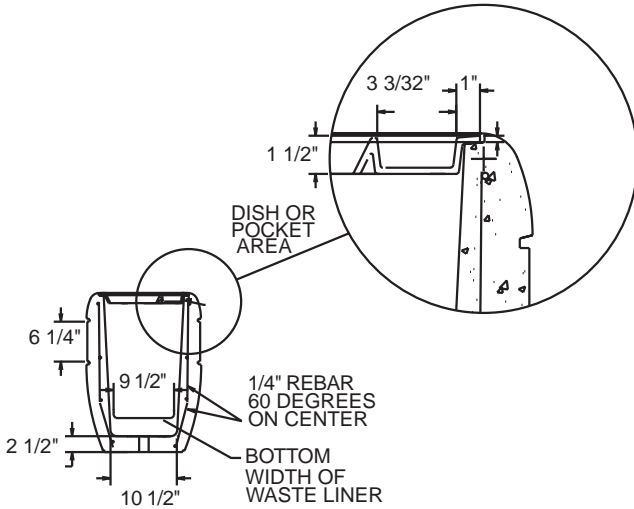

**SECTION VIEW OF WASTE CONTAINER**

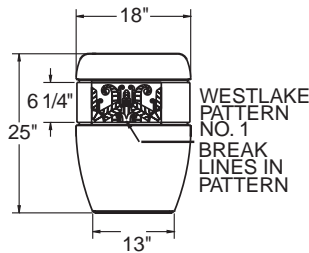

**SIDE VIEW OF WASTE CONTAINER**

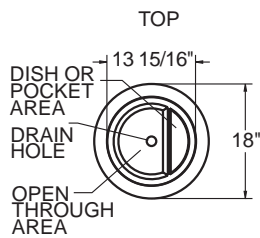

**TOP VIEW OF WASTE CONTAINER**

## 1.1 SUMMARY

- A. Section includes: Furnish Precast Concrete Snuffers indicated on drawings or specified herein.

## 1.2 REFERENCES

- A. American Society for Testing & Material
  1. ASTM C33
  2. ASTM C150
  3. ASTM C31

## 1.5 SUBMITTALS

- A. Submit product data, shop drawings and samples.
  1. Product Data: Manufacturer's specifications and technical data edited specifically for proposed system, including the following specific information:
    - a. Detailed specification of construction fabrication.
    - b. Manufacturer's installation instructions
    - c. Maintenance literature
    - d. Product warranty
  2. Shop Drawings: Indicate pertinent dimensions, general construction, component connections anchoring methods, hardware and installation procedures.
  3. Samples as requested by Architect.

## 1.6 QUALITY ASSURANCE

- A. Qualifications of Manufacturer: Manufacturer to be prequalified by specifier prior to bidding. Failure to comply will result in disqualification of bid. Manufacturer to have at least five years experience in the manufacturer of precast concrete snuffers field proven for at least five years.

## 1.10 WARRANTY

Manufacturer shall submit a written warranty for precast products for the period of two years upon acceptance of products.

## 2.1 MANUFACTURERS

- A. Acceptable manufacturer for Precast Concrete Snuffers to be known as Wausau Tile, Inc.  
Terra-Form Division.  
P.O. Box 1520  
Wausau, WI 54402-1520.  
(800) 388-8728 (715) 359-3121 FAX (715) 355-4627
- B. Clarification Note: Drawings and installation specification are based on manufacturers proprietary literature from Wausau Tile, Inc. Other manufacturers shall comply with minimum levels of material and detailing indicated on drawings or specified herein.
- C. All Precast products for this project shall be of one manufacturer.

## 2.2 MATERIALS

- A. Portland Cement: ASTM C150 specifications for Portland Cement.
- B. Aggregates: All aggregates to meet ASTM C33 specifications, to be cleaned of foreign matter and properly graded to size.
- C. Coloring: Pigments used shall be inorganic, resistant to alkalinity and used as per manufacturers recommendations.

# # #